



*Handwritten initials*

**FOR RELEASE: FRIDAY PM'S  
May 21, 1965**

RELEASE NO: 65-158

*XII*  
**PROJECT: GEMINI 4**  
*W*

*June flight*

**P  
R  
E  
S  
S  
  
K  
I  
T**

**CONTENTS**

GENERAL NEWS RELEASE.....1-4

BACKGROUND INFORMATION

- Possible Extravehicular Activity.....5
- Primary Objectives.....6
- Secondary Objectives.....6
- Mission Description.....7-12
- Flight Data.....12
- Weather Requirements.....12-14
- Countdown.....15-16
- Flight Crew Activities.....17-18
  - Immediate Preflight Crew Activities.....18-19
  - Flight Activities.....19-22
  - Post Flight Activities.....23
- Crew Safety.....24
  - During Launch.....24-27
  - Abort Procedures (Illustration).....25
  - Inflight.....28-29
  - Reentry, Landing, Recovery.....29-33
  - Parachute Landing Sequence (Illustration)31
- Gemini Survival Package.....34-36
- Manned Space Flight Tracking Network.....37-38
  - Goddard Computer Support.....38-39
  - Mission Control Center, Cape Kennedy.....39-40
  - NASA Communications Network.....40-42
  - Spacecraft Communications.....42
  - Network Responsibility.....43-44
  - Network, Configuration, Capability.....45
- Medical Checks.....46
  - Cardiovascular Effects of Space Flight...46-47
- Gemini 4 Experiments.....48

Launch is scheduled no earlier than June 3.

In-Flight Phonocardiogram.....	49
Bond Demineralization.....	49
Electrostatic Charge.....	50-51
Proton-Electron Spectrometer.....	51-52
Tri-Axis Flux-Gate Magnetometer.....	53-54
Two-Color Earth's Limb Photography.....	54-56
Synoptic Terrain Photography.....	57-59
Synoptic Weather Photography.....	60-62
Food for Gemini 4.....	63-64
Gemini 4 Menu.....	65-68
Gemini Spacecraft.....	69
Reentry Module.....	69-70
Adapter Section.....	70-76
Liquid Rocket Systems (Illustration).....	71
Thrust Chamber Arrangement (Illustration).....	72
Maneuvering Control (Illustration).....	73
Response to Control Thrust (Illustration).....	74
RCS Function (Illustration).....	75
Gemini Launch Vehicle.....	77-80
Gemini Space Suit.....	81-82
Crew Biographies.....	83
James A. McDivitt.....	83
Edward H. White II.....	84
Frank Borman.....	85
James A. Lovell, Jr.....	86
Project Officials.....	87
Previous Gemini Flights.....	88-90
Orbits-Revolutions.....	91

- 0 -

NOTE TO EDITORS:

Supplemental information will be released as rapidly as it develops.

**FOR RELEASE: FRIDAY PM'S**  
May 21, 1965

RELEASE NO: 65-158

NASA SCHEDULES FOUR-DAY  
MANNED GEMINI FLIGHT  
FROM CAPE KENNEDY

The National Aeronautics and Space Administration will launch the United States' longest duration manned space flight to date from Cape Kennedy, Fla., no earlier than June 3.

The two-man Gemini 4 mission is scheduled to circle the Earth 62 times in four days to evaluate the effects of extended space flight on crew performance and physical condition.

Astronaut James A. McDivitt is command pilot and Astronaut Edward H. White II is pilot for the flight. Astronauts Frank Borman and James A. Lovell, Jr., the back-up crew, will replace the primary crew should either member of that team become ineligible for the flight.

The mission is designated Gemini 4--the fourth of 12 flights planned in the Gemini project. The first two missions, Gemini 1 and Gemini 2, were unmanned. Astronauts Virgil Grissom and John Young orbited the Earth three times March 23 in Gemini 3.

A successful full-duration Gemini 4 flight will more than triple the manned space flight time accumulated by the United States. To date the U.S. has nearly 65 man-hours in space and the Gemini 4 mission would bring the total to about 257 man-hours. Total U.S. manned spacecraft time in space would be about 154 hours after the 97-hour-and-50-minute Gemini 4 flight.

Gemini 4 will be launched by a two-stage Titan II, a modified U.S. Air Force Intercontinental Ballistic missile, into an orbit with a high point (apogee) 185 miles and low point (perigee) of 100 miles above the Earth. Each orbit will take about 90 minutes and range between 33 degrees north and south of the Equator.

Recovery is planned in the Atlantic Ocean about 400 miles south of Bermuda.

Eleven experiments are planned for Gemini 4. Three of these are medical, four engineering, two Department of Defense and two scientific.

The medical experiments will study effects of exercise and work in space, time heart contractions with a phonocardiogram and determine whether bone demineralization takes place on long space flights.

Engineering experiments will measure electrostatic charges on the spacecraft surface, measure radiation immediately around the spacecraft, monitor direction and amplitude of the Earth's magnetic field with respect to the spacecraft and make two-color photographs of the Earth's "limb" (the outer edge of brightness).

DOD experiments concern radiation measurements inside the spacecraft and simple devices for navigation.

Scientific experiments include wide-angle terrain and weather photography.

The Gemini 4 mission marks the first time that mission control will be exercised at the Manned Spacecraft Center, Houston. The Mission Control Center at Houston was used to monitor the Gemini 3 mission but control of that mission and all the Mercury manned space flights was done at Cape Kennedy.

The Gemini program is the second phase of the United State's manned space flight program. It is designed to provide experience in orbiting maneuvers, rendezvous and docking, space flights lasting up to 14 days and for manned scientific investigations in space.

Gemini is under the direction of the Office of Manned Space Flight, NASA Headquarters, Washington, D.C., and is managed by NASA's Manned Spacecraft Center, Houston. Gemini is a national space effort and is supported by the Department of Defense in such areas as launch vehicle development, launch operations, tracking and recovery.

(BACKGROUND DATA FOLLOWS)

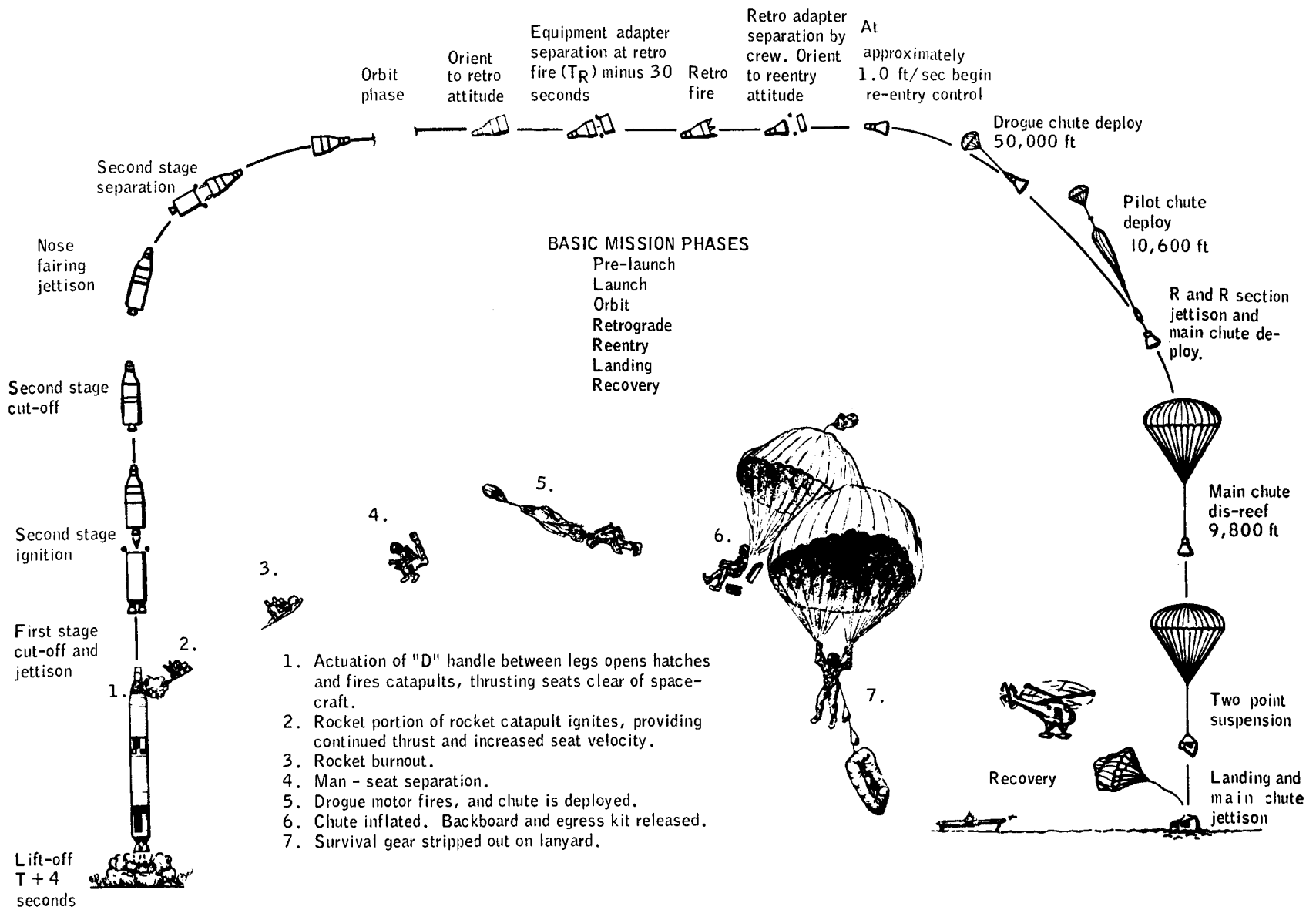

Gemini 4 Significant Events

POSSIBLE EXTRAVEHICULAR ACTIVITY

No decision has been made whether in the Gemini 4 mission the crew will engage in extravehicular activity. This will depend on the qualifying of the extravehicular space suits and the hatch.

During their training the Gemini 4 crew performed a simulated extravehicular test in the vacuum chamber at McDonnell Aircraft Corp., at a simulated altitude of 150,000 feet.

A decision to undertake the extravehicular test can be made as late as the day before the launch.



GEMINI 4 PRIMARY OBJECTIVES

1. Demonstrate and evaluate performance of the spacecraft systems for a period exceeding four days.
2. Evaluate effects of prolonged exposure to the space environment of the two-man flight crew in preparation for flights of longer duration.

GEMINI 4 SECONDARY OBJECTIVES

1. Demonstrate Orbital Attitude and Maneuver System's capability to perform retrofire back-up.
2. Demonstrate capability of the spacecraft and flight crew to make in-plane and out-of-plane maneuvers.
3. Conduct further evaluation of spacecraft systems as outlined in inflight systems test objectives:
  - a. Structure and thermal protection system.
  - b. Environmental control system.
  - c. Crew station.
  - d. Guidance and control system.
  - e. Orbital Attitude and Maneuver System (OAMS).

4. Execute the following experiments:
  - a. M-3 inflight exerciser.
  - b. M-4 inflight phonocardiogram.
  - c. M-6 bone demineralization.
  - d. MSC-1 electrostatic charge.
  - e. MSC-2 proton electron spectrometer.
  - f. MSC-3 tri-axis magnetometer.
  - g. MSC-10 two-color Earth's limb photographs.
  - h. D-8 radiation in spacecraft.
  - i. D-9 simple navigation.
  - j. S-5 synoptic terrain photography.
  - k. S-6 synoptic weather photography.

#### MISSION DESCRIPTION

The spacecraft will be launched from Pad 19 on a true azimuth of 72 degrees east of north. Slightly more than six minutes after liftoff, it will be inserted into a 100-185-statute-mile orbit inclined approximately 32.5 degrees to the Equator. (All miles are statute).

Orbital insertion will occur about 680 miles from Cape Kennedy at a velocity of 25,766 feet per second (17,567 miles per hour), including up to 10 feet per second provided by the spacecraft's aft-firing thrusters during the separation maneuver.

While in orbit, maneuvers totaling 55 feet per second will be used to adjust the orbital lifetime and to demonstrate the maneuvering ability of the spacecraft. Additional maneuvers totaling 25 feet per second will be performed separately, but in conjunction with orbit adjustment maneuvers, to check out operational procedures.

Retrofire is planned at 97 hours, 31 minutes and 43 seconds after liftoff as Gemini 4 is passing over the west coast of the United States before the end of the 62nd revolution. Landing is expected approximately 17 minutes after retrofire in the Atlantic Ocean about 400 miles south of Bermuda.

Each of the maneuvers will be calculated in realtime and adjusted to meet requirements as determined by the mission director. The maneuvers planned are:

Separation Maneuver -- Twenty seconds after the launch vehicle's second stage engine cuts off (SECO), the command pilot will activate the two aft-firing thrusters for 12 seconds to apply up to 10 feet per second forward velocity to the spacecraft to separate it from the launch vehicle. He will not control the spacecraft attitude during the first two seconds of thrust, then he will control attitude to 0 degrees roll, 0 degrees yaw and -20 degrees pitch for the remainder of the burn.

At Second Apogee -- The forward velocity will be increased seven feet per second to raise the perigee and achieve a five-day lifetime. Prior to burn, the command pilot will yaw the spacecraft 180 degrees, placing the blunt end forward, and the two forward-firing, 85-pound thrust engines will be used for the maneuver. About 11 seconds of thrust will be required. The perigee of the orbit will be raised to 105 miles and the apogee will remain at 185 miles.

At 30th Apogee -- Forward velocity will be increased 12 feet per second to raise the perigee and achieve a three-day lifetime. The 100-pound left-firing thruster will be used and it will be necessary to yaw the spacecraft -64 degrees to align the thruster with the velocity vector. Thrusting time will be about 30 seconds.

Between 30th Apogee and 30th perigee -- A series of five foot per-second maneuvers will be performed to evaluate thruster operation and to determine visual characteristics of thruster plumes. The burns will be performed at five-minute intervals.

The first will be up, using the 100-pound down-firing thruster while the spacecraft is at a -26-degree pitch angle to align the thruster perpendicular to the velocity vector.

The second will be down, utilizing the 100-pound up-firing thruster while the spacecraft is at a pitch angle of 26 degrees to align the thruster perpendicular to the velocity vector.

The third will be to the left utilizing the 100-pound right-firing thruster while the spacecraft is at a yaw angle of -26 degrees to align the thruster perpendicular to the velocity vector.

Approximately 12 seconds of thrust will be required for each maneuver.

At 30th Perigee -- A maneuver will be performed to evaluate the application of a three-axis change in velocity using the two 100-pound aft-firing thrusters. The spacecraft attitude will be -169.3 degrees yaw and 10.9 degree pitch, Velocity values will be 26 feet per second aft, five feet per second up and five feet per second left. About 34 seconds of thrust will be required. At the end of all the maneuvers beginning at the 30th apogee, the spacecraft will be in a 108-154-mile orbit.

At 45th Apogee -- Forward velocity will be increased four feet per second to raise the perigee and achieve a two-day lifetime. The 85-pound forward-firing thrusters will be used while the spacecraft is in a 180-degree yaw attitude. Burn time will be about seven seconds.

At 45th Perigee -- A six-foot aft burn, using the forward firing thrusters, will be made to lower the apogee. Spacecraft attitude will be 0 degrees in all axes. Thrusting time will be about 10 seconds. At the end of the two maneuvers in the 45th orbit, the orbital elements will be 107-143 miles.

Twelve minutes before Retrofire -- An Orbital Attitude and Maneuver System retrograde maneuver of about 110 feet per second will be performed to provide a reentry trajectory

even if the retrorockets should not fire. The aft-firing thrusters will be used while the spacecraft is in a 180-degree yaw attitude. Burn time will be about 116 seconds.

#### FLIGHT DATA

Launch Azimuth -- 72 degrees.

Flight Duration -- Approximately 97 hours, 50 minutes.

Initial Orbital Parameters -- 100 -185 miles.

Reentry Velocity -- About 24,000 feet per second, 16,450 miles per hour.

Reentry temperature -- About 3,000 degrees Fahrenheit on surface of heat shield.

Landing Point -- Atlantic Ocean about 400 miles south of Bermuda, 25.20 degrees north, 65 degrees west.

Oxygen -- Primary 52 pounds, Secondary 13 pounds.

Cabin Environment -- 100 per cent oxygen pressurized at five pounds per square inch.

Retrorockets -- Each of four retrorockets produces approximately 2,500 pounds of thrust for 5.5 seconds. Will fire separately.

#### WEATHER REQUIREMENTS

Recovery capability is based primarily on reports from recovery force commanders to the recovery task force command at Mission Control Center.

The following are guide lines only. Conditions along the ground track will be evaluated prior to and during the mission.

Launch Area

Surface Winds -- 18 knots with gusts to 25 knots.

Ceiling -- 5,000 feet cloud base minimum.

Visibility -- Six miles minimum.

Wave Height -- Five feet maximum.

Planned Landing Areas

Surface Winds -- 30 knots maximum

Ceiling -- 1,500 feet cloud base minimum.

Visibility -- Six miles minimum.

Wave Height -- Eight feet maximum.

Contingency Landing Areas

Weather and status of contingency recovery forces will be continually monitored. Recommendations will be made to the Mission Director who will make the go-no-go decision based upon conditions at the time.



Pararescue

The decision to use pararescue personnel depends upon weather conditions, surface vessel locations and the ability to provide air dropped supplies until the arrival of a surface vessel. The final decision to jump will be made by the jump-master. Weather guidelines for pararescue operations are:

Surface Winds -- 25 knots maximum.

Ceiling -- 1,000 feet cloud base minimum.

Visibility -- Target visible.

Waves -- Five feet maximum, swells 10 or 11 feet maximum.

LAUNCH COUNTDOWN

T-1 day	Preparations for launch countdown.
T-270 minutes	Awaken crew.
T-240 minutes	Begin countdown.
T-225 minutes	Engine cutoff, shutdown and destruct test complete.
T-190 minutes	Start electrical connection of Stage I and II destruct initiators.
T-175 minutes	Ordnance electrical connections complete, safety pins removed; blockhouse door sealed.
T-170 minutes	Begin sensor placement and suiting of crew.
T-168 minutes	Launch vehicle tank pressurization completed.
T-150 minutes	Start launch vehicle securing preparations.
T-120 minutes	Verify launch vehicle "Go" for flight; simulated malfunction test.
T-100 minutes	Crew enters spacecraft.
T-60 minutes	White Room evacuation complete; erector lowering preparations complete; erector cleared to lower.
T-35 minutes	Start lowering erector; start range telemetry readout.
T-30 minutes	Activate spacecraft communications links.
T-25 minutes	Spacecraft to internal power.
T-20 minutes	Command transmitter on.
T-15 minutes	Spacecraft static firing.
T-6 minutes	Final status and communications check.
T-5 minutes	Start range telemetry recorders.
T-4 minutes	Start analog and event recorders.

T-3 minutes	Set in launch azimuth (72 degrees).
T-2 minutes, 30 seconds	Range clearance.
T-1 minute, 30 seconds	Roll program armed.
T-0	Engine start signal.

FLIGHT CREW ACTIVITIES, GEMINI 4

The Gemini 4 flight crew was selected July 27, 1964. Concentrated mission training began in September. In addition to the extensive general training received prior to flight assignment--such as familiarization with high accelerations, zero gravity, and various survival techniques--the following preparations have or will be accomplished prior to launch:

- a. Familiarization with launch, launch abort, and reentry acceleration profiles of the Gemini 4 mission using the Naval Air Development Center, Johnsville, Pa., centrifuge.
- b. Egress and recovery activities using a spacecraft boilerplate model and actual recovery equipment and personnel.
- c. Celestial pattern recognition in the Moorehead Planetarium, Chapel Hill, N.C.
- d. Hatch-open and standup exercises at a simulated 150,000 ft. in the McDonnell Aircraft Corp. pressure chamber.
- e. Parachute descent training over land and water using a towed parachute technique.
- f. Zero gravity evaluation of extra vehicular activities, food and other on-board equipment.
- g. Suit, seat, and harness fittings.
- h. Launch abort simulations at Ling-Temco-Vought in a specially configured simulator.

i. Training sessions totaling over 110 hours per crew member on the Gemini mission simulators.

j. Detailed systems briefing; detailed experiment briefings; flight plan and mission rules reviews.

k. Participation in mock-up reviews, Service Engineering Department Report (SEDR) reviews, subsystem tests, and spacecraft acceptance review.

In final preparation for flight, the crew participants in network launch abort simulations, joint combined systems test, wet mock simulated launch, and the final simulated flight test. At T-2 days, the major flight crew medical examinations will be administered to determine readiness for flight and obtain data for comparison with post flight medical examination results.

#### Immediate Preflight Crew Activities

Seven hours prior to launch, the back-up flight crew reports to the 100-foot level of the White Room to monitor the positioning of all cockpit switches. By T-5 hours, the pilots' ready room, the 100-foot level of the White Room and the crew quarters are manned and made ready for the primary crew.

T-4 hours, 30 minutes	Primary crew awakened
T-4 hours	Medical examination
T-3 hours, 40 minutes	Breakfast
T-3 hours	Crew leaves O&C (Operations and Checkout) Building
T-2 hours, 50 minutes	Crew arrives at ready room on Pad 16

During the next hour, the biomedical sensors are placed, underwear and signal conditioners are donned, flight suits minus helmets and gloves are put on and blood pressure is checked. The helmets and gloves are then attached and communications and oral temperature systems are checked.

T-2 hours	Purging of suit begins
T-1 hour, 49 minutes	crew leaves ready room
T-1 hour, 44 minutes	Crew arrives at 100-foot level
T-1 hour, 40 minutes	Crew enters spacecraft

From entry until ignition, the crew participates in or monitors system checks and preparations.

#### Flight Activities

At ignition the crew begins the primary launch phase task of assessing system status and detecting abort situations. At 45 seconds after staging the command pilot jettisons the nose and horizon scanner fairings. Twenty seconds after SECO, the command pilot initiates forward thrusting and the pilot

actuates spacecraft separation and selects rate command attitude control. Ground computations of insertion velocity corrections are received and velocity adjustments are made by forward or aft thrusting. After successful insertion and completion of the insertion check list, the detailed flight plan is begun.

In addition to frequent housekeeping tasks such as systems tests, biomedical readouts and eating, the following significant events are planned:

<u>Orbit</u>	<u>Events</u>
1	Thruster and control mode check, communications systems check, D-9 experiment (star to booster sextant measurements).
2	Translation maneuver and night Apollo yaw orientation check.
4	Tracking tasks and synoptic weather photography.
5-6	Command pilot sleeps, MSC-2 experiment (proton electron measurement), MSC-3 (magnetic field measurement), M-3 (exercise) and MSC-10 (two-color Earth limb photography).
8	Command pilot awakes, D-8 experiment (radiation measurements), pilot sleeps.

9 D-9 experiment (star and horizon sextant sightings).  
11 Pilot awakes.  
12 M-3 (exercise).  
13 Command pilot sleeps.  
16 S-5 (synoptic terrain photography), command pilot  
awakes, pilot sleeps.  
17 High frequency communications tests.  
19 Pilot awakes, D-9 (star and horizon sextant measurements).  
20 Command pilot sleeps S-6 (synoptic weather photography).  
21 MSC-2 (proton and electron measurements), MSC-3  
(magnetic field measurements), D-8 (radiation  
measurements), S-5 (synoptic weather photography).  
22 D-8 (radiation measurements), S-5 (synoptic weather  
photography).  
23 Command pilot awakes, pilot sleeps.  
25 Pilot awakes.  
26 M-3 (exercise).  
27 Command pilot sleeps, S-6 (synoptic weather photography).  
28 S-5 (synoptic terrain photography).  
29 S-6 (synoptic weather photography), M-3 (exercise).  
30 Command pilot awakes, translation maneuvers.  
31 Power down spacecraft, pilot sleep starts, S-5  
(synoptic terrain photography), S-6 (synoptic weather  
photography).



33 Pilot awakes.

34 M-3 (exercise).

35 Command pilot sleeps D-9 (star to horizon sextant  
measurements), MSC-2 (proton and electron measurements),  
MSC-3 (magnetic field measurements).

36 S-6 (synoptic weather photography).

37 S-6 (synoptic weather photography).

38 Command pilot awakes, pilot sleeps, D-9 (sextant  
measurements).

40 Pilot awakes.

45 Power up and align platform.

46 Translation maneuver, M-3 (exercise).

47 Translation maneuvers, Apollo yaw orientation, pilot  
sleeps.

49 Pilot awakes, M-3 (exercise).

50 D-9 (sextant measurements), command pilot sleeps.

53 Command pilot awakes, pilot sleeps.

56 Pilot awakes.

57 M-3 (exercise).

60 M-3 (exercise), end of missions systems checkout.

62 Pre-retro checklist,  $T_R$ -5-minute checklist,  $T_R$ -1-  
minute checklist, retrofire, retro jettison, post-  
retro checklist.

63 Reentry, drogue deploy, main chute deploy, two-  
point suspension, impact, post-landing checklist.

Post Flight Activities.

The post flight activities will involve expanded medical evaluations compared with previous missions. It is planned the flight crew will spend three nights aboard the recovery carrier performing taped debriefings and undergoing extensive medical examinations. They will return to Houston for a press conference and then will report for more extensive medical examinations and complete systems debriefings for eight to 10 days after recovery.

### CREW SAFETY

Crew safety is paramount. Gemini represents thousands of hours of design, modification, fabrication, inspection, testing and training. Every component or system critical to crew safety has a redundant (back-up) feature.

#### During Launch

The malfunction detection system (MDS) in the launch vehicle is the heart of crew safety during the powered phase of flight -- lift-off to second stage shut-down.

This system was designed for the Gemini launch vehicle and had no counterpart in the Titan weapon system. Its function is to monitor Gemini launch vehicle subsystem performance and warn the crew of a potentially catastrophic malfunction in time for escape, if necessary. The MDS monitors engine thrust for both stages, steering rates, propellant tank pressures, staging, Stage I hydraulic pressure, a spacecraft switchover command or engine hardover.

During the powered phase of flight there are three modes for crew escape. These are (1) ejection seats, (2) firing the

# ABORT PROCEDURES

MODE I - EJECT AFTER SHUTDOWN

MODE II - SALVO RETROS AFTER SHUTDOWN

MODE III - SHUTDOWN, SEPARATE, TURN AROUND, RETROFIRE

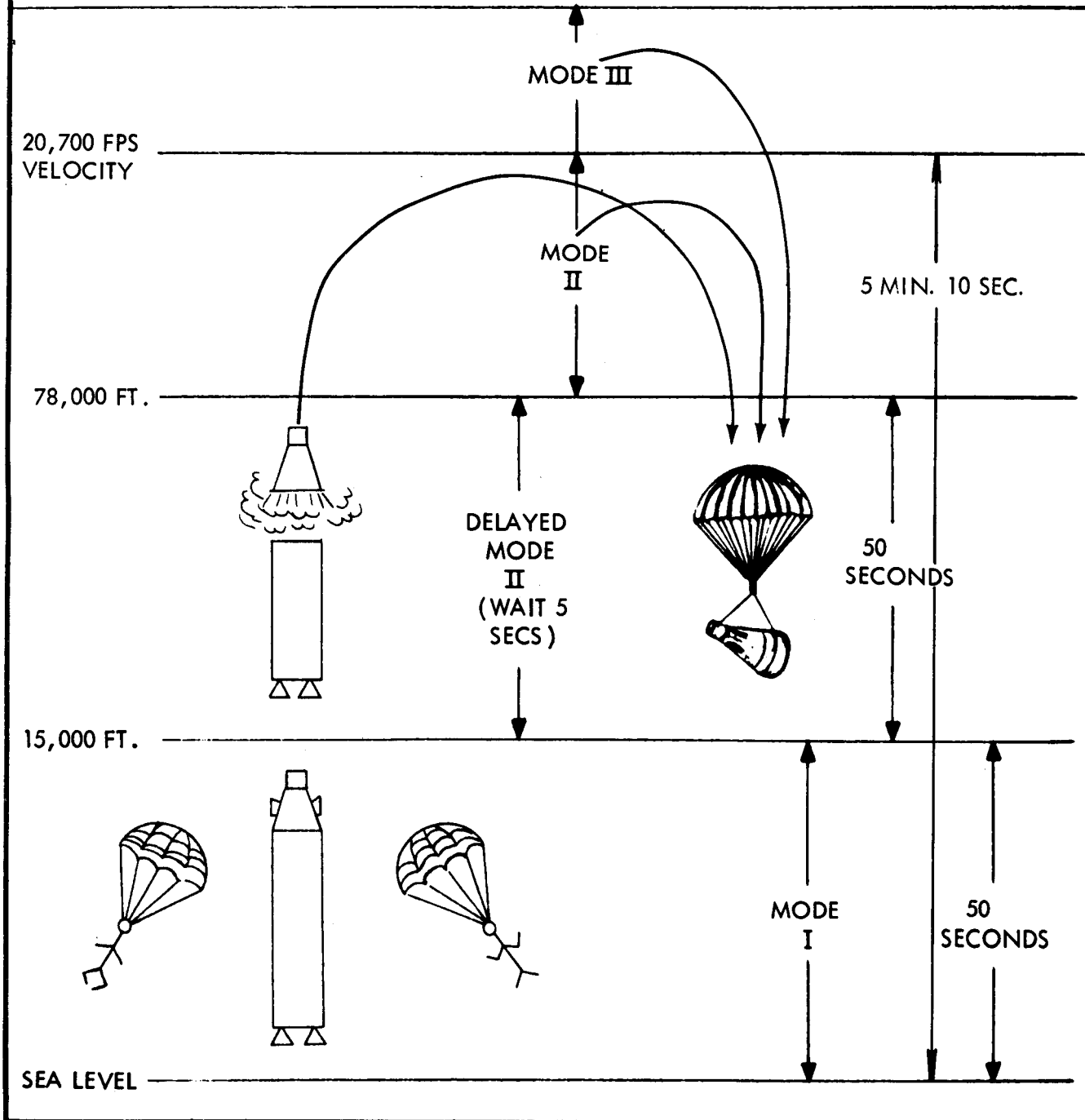

retro-rockets to separate the spacecraft from the launch vehicle, then initiating the spacecraft recovery system, (3) normal spacecraft separation followed by use of the thrusters and retro-rockets. For malfunctions dictating retro-abort mode which occur between 15,000 and 76,000 feet, the astronauts will not initiate abort until aerodynamic pressure has decreased to the point where successful separation of the spacecraft from the launch vehicle is assured.

Escape procedures will be initiated by the command pilot following two valid cues that a malfunction has occurred. The particular malfunction and the time at which it occurs will determine abort procedures as follows:

1. Lift-off to 15,000 feet (50 seconds) -- Immediate ejection for all malfunctions.
2. 15,000 (50 seconds) to 78,000 feet (100 seconds) -- Delayed retro-abort for all malfunctions. This action consists of arming abort circuits, waiting until aerodynamic pressure has decreased, then salvo firing the four retro-rockets to separate from the launch vehicle. This delay requires approximately five seconds.
3. After the launch vehicle is above 78,000 feet, aerodynamic drag will have decreased to the point where no delay

between engine shutdown and retro-abort is required for successful separation. Retro-abort will be used until a velocity of approximately 20,700 ft/sec (14,000 mph) or 80 percent of that required to get into orbit is achieved. For rapid malfunctions, retro-abort will be initiated immediately after receipt of two valid cues. For slow malfunctions and most spacecraft malfunctions, retro-abort will be initiated at a fixed time in order to land near pre-positioned recovery vessels.

In boost-phase aborts where more than 80 percent of velocity required for orbit has been achieved, the normal spacecraft separation sequence is used for all malfunctions. The most probable cause of abort in this area would be early shutdown of the booster due to fuel depletion. Also, abort might be requested by ground monitors if the trajectory exceeds acceptable limits. The general abort plan in this flight regime is to separate from the launch vehicle, assume retroattitude, insert landing area parameters in the spacecraft computer, retrofire, and descend to a planned recovery area.

### Inflight

There are no single point failures which would jeopardize crew safety during inflight operations. All systems and sub-systems have back-up features or there is an alternate method.

The Environmental Control System (ECS) controls suit and cabin atmosphere, crew and spacecraft equipment temperatures and provides drinking water and a means of disposing of waste water.

The space suit itself is a back-up system. Should cabin pressure fail, the spacesuit provides life support.

It is a full pressure suit which works in conjunction with the ECS. Gaseous oxygen is distributed through the suit ventilation system for cooling and respiration and provisions allow the astronaut to take in drinking water while in a hard suit (pressurized) condition.

A 100-percent oxygen environment at 5 pounds per square inch in a pressurized cabin or 3.7 psia in an unpressurized cabin is provided in spacesuit by the ECS. Additional oxygen

is available from tanks in the reentry module in case of emergency and for use during reentry.

In event the flight must be terminated before mission completion, the Gemini propulsion systems will permit a controlled landing in a contingency recovery area.

### Reentry, Landing and Recovery

The Reentry Control System (RCS) controls the spacecraft attitude during retrorocket firing and reentry. Two complete and independent systems provide 100 percent redundancy. The four retrorockets are wired with dual igniters.

The Orbit Attitude and Maneuver System (OAMS) serves as a back-up safety feature should the retrorockets fail to fire. In case of retrorocket failure the OAMS will have been used to lower the orbit to the point where gravity and atmospheric drag would cause spacecraft reentry.

The OAMS is normally used to perform translation maneuvers along three axes of the spacecraft and provide attitude control during orbital phases of the mission.



In Gemini 4, should the retrorockets fail, reentry will occur near Ascension Island in the South Atlantic.

Parachutes are used for descent following spacecraft reentry. The crew has an excellent view of parachute deployment through the spacecraft windows. If there is a parachute malfunction the crew will eject themselves from the spacecraft and use their personal chutes for landing. Survival equipment is carried on the backs of the ejection seats and remains attached to the astronauts until they land.

Recovery forces will be provided by the military services and during mission time will be under the operational control of the Department of Defense Manager for Manned Space Flight Support Operations.

Planned and contingency landing areas have been established. Planned areas are those where the probability of landing is sufficiently high to justify pre-positioning of recovery forces for support and recovery of crew and spacecraft within given access times.

# GEMINI PARACHUTE LANDING SEQUENCE

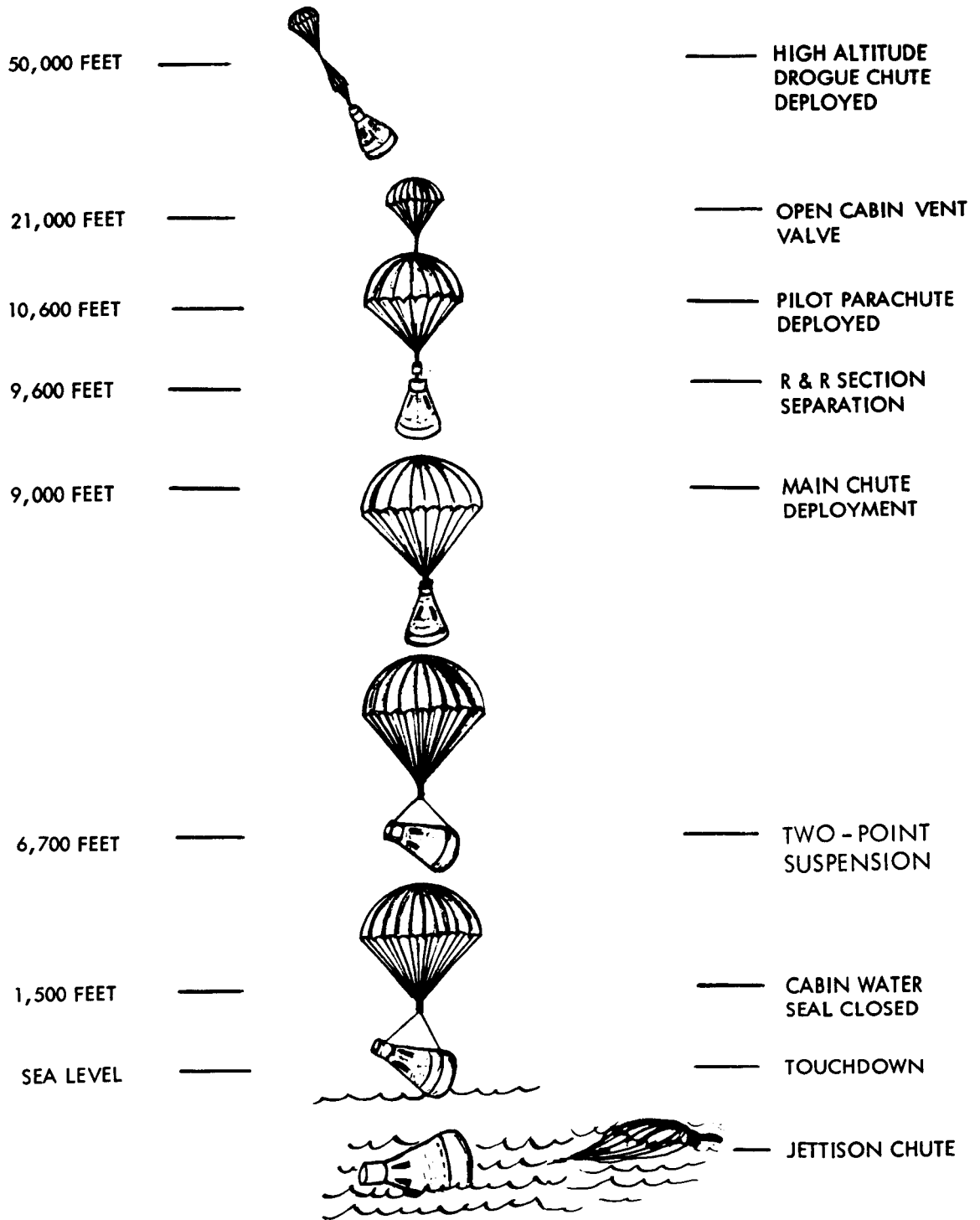

Contingency areas are all other areas along the ground track where the spacecraft could possibly land. The probability of landing in a contingency area is sufficiently low that special search and rescue techniques will provide adequate recovery support.

There are four types of planned landing areas:

1. Primary Landing Area -- Landing will occur with normal termination of the mission after 63 orbits. This area is in the Atlantic Ocean, about 400 miles south of Bermuda.

2. Secondary Landing Areas -- where a landing would occur if it is desirable to terminate the mission for any cause. Ships and aircraft will be stationed to provide support. Aircraft will be able to drop pararescue personnel and flotation equipment within one hour after spacecraft landing.

3. Launch Abort Landing Areas -- Along the launch ground track between Florida and Africa where landings would occur following aborts above 45,000 feet and before orbital insertion.

Surface ships with medical personnel and retrieval equipment, and search and rescue airplanes with pararescue personnel, flotation equipment and electronic search capability will be stationed in this area before launch. After the successful insertion of the spacecraft into orbit, some of the ships and planes will deploy to secondary areas to provide support on a later orbit, and the remainder will return to home stations.

4. Launch Site Landing Area -- Landing will occur following an abort during countdown, launch and early powered flight in which ejection seats are used. It includes an area of approximately 26 miles seaward and three miles toward the Banana River from Pad 19. Its major axis is oriented along the launch azimuth.

A specialized recovery force of land vehicles, amphibious craft, ships and boats, airplanes and helicopters will be stationed in this area from the time the astronauts enter the spacecraft until lift-off plus five minutes.

Recovery access time varies from 0 minutes for a water landing to 10 minutes for a land landing. The astronauts will be taken to the Patrick Air Force Base hospital for examinations after pickup.

Contingency Landing Areas:

Search and rescue aircraft equipped with electronic search equipment, pararescue men and flotation equipment will be staged along the ground and sea track so that the spacecraft will be located and assistance given to the astronauts within 18 hours after the recovery forces are notified of the probable landing position.

GEMINI SURVIVAL PACKAGE

The Gemini survival package contains 14 items designed to support an astronaut if he should land outside normal recovery areas.

The package weighs 23 lbs. and has two sections. One section, holding a  $3\frac{1}{2}$ -pound water container and machete is mounted by the astronaut's left shoulder. The main package, containing the life raft, and related equipment, is mounted on the back of the ejection seat. Both packages are attached to the astronaut's personal parachute harness by a nylon line. After ejection from the spacecraft, as the seat falls clear and the parachute deploys, the survival kit will hang on a line, ready for use as soon as the astronaut lands.

Inflated, the one-man life raft is five and one half ft. long and three ft. wide. A CO<sub>2</sub> bottle is attached for inflation. The raft is also equipped with a sea anchor, sea dye markers, and a sun bonnet of nylon material with an aluminized coating which the astronaut can place over his head.

In his survival kit, the astronaut also has a radio beacon, a combination survival light, sunglasses, a medical kit, and a desalter kit assembly.

The combination survival light is a new development for the Gemini kit, combining many individual items which were carried in the Mercury kit. About the size of a paperback novel, it contains a strobe light for signaling at night, a flashlight, and a signal mirror built in on the end of the case. It also contains a small compass.

There are three cylindrical cartridges inside the case. Two contain batteries for the lights. The third contains a sewing kit, 14 feet of nylon line, cotton balls and a striker for kindling a fire, halazone tablets for water purification and a whistle.

The desalter kit includes eight desalter brickettes, and a processing bag. Each brickette can desalt one pint of seawater.

The medical kit contains a one-cubic-centimeter injector for pain, and a two-cubic-centimeter injector for motion sickness. There also are stimulant, pain, motion sickness, and antibiotic tablets and aspirin.

MANNED SPACE FLIGHT TRACKING NETWORK

The Manned Space Flight Network for Gemini 4 is composed of spacecraft tracking and data acquisition facilities throughout the world, a Mission Control Center at Cape Kennedy, a real - time (no delay) computing and communications center at the Goddard Space Flight Center, Greenbelt, Md., and a Mission Control Center in NASA's Manned Spacecraft Center, Houston.

The basic network consists of seven primary land sites, two ships, (the Rose Knot and Coastal Sentry) six additional land stations, and remote voice data switching sites. This network and its operating procedures remain unchanged from the Gemini 3 mission, however, primary mission control and computing responsibilities will switch from the Mission Control Center, Cape Kennedy, and Goddard Space Flight Center, to the Manned Spacecraft Center.

The locations of the land stations are as follows:

<u>Primary Stations</u>	<u>Additional Stations</u>
Cape Kennedy, Fla., and down- range Air Force Eastern Test Range sites	Kano, Nigeria Madagascar (Tananarive)
Bermuda	Canton Island
Grand Canary Island	Point Arguello, Calif.



Carnarvon, Australia

White Sands, N.M.

Hawaii

Eglin AFB, Fla.

Guaymas, Mexico

Corpus Christi, Tex.

Two Ships: The Rose Knot  
and Coastal Sentry

Other tracking and data acquisition facilities, such as relay aircraft, instrumentation ships, communications, relay stations, etc., will be called up as required and integrated into the basic network.

#### Goddard Computer Support

Countdown phase--The Goddard Realtime Computing Center will provide back-up computing support to the Manned Spacecraft Center Realtime Computing Complex throughout the mission. During the pre-launch countdown Goddard will be responsible for checking the Manned Space Flight Network's readiness to support Gemini 4 through its CADFISS (Computer and Data Flow Integrated Subsystems) Tests.

The Goddard Realtime Computing Center also will provide prime computer support for all network tracking and data acquisition systems (Radars-Digital Command System-Pulse Code Modulation telemetry and the Launch Monitor Subsystem) roll call.

Data flow tests from the world-wide network to the Manned Spacecraft Center's Realtime Computing Complex will be conducted from MSC RTCC under the direction of Goddard's CADFISS Test Director.

Launch Phase--During powered flight, Goddard's realtime computers will receive launch trajectory data from NASA's Bermuda tracking station, compute the trajectory and display the data on plotboards and consoles at Mission Control Center, Cape Kennedy.

Orbit Phase--During the orbit phase, Goddard's computing center will update the orbit based on data received from network radars. Refined orbital parameters will be displayed at Mission Control Center, Cape Kennedy as required.

Mission Control Center - Cape Kennedy

The Mission Control Center, Cape Kennedy is technically supervised, operated and maintained by Goddard. During Gemini 4 it will be full-time back-up to Mission Control Center, Houston. It will operate on a 24-hour basis in concert with Houston Mission Control requirements.

During the launch phase, Kennedy Mission Control will provide realtime data display and command control capability for its flight control team. In the event of communications breakdown from Houston, the Kennedy flight-control team will be able to assume flight direction and control immediately.

Kennedy Mission Control also will provide flight dynamics data simultaneously to Goddard and Houston computers for the critical "Go-No-Go" orbital insertion decision. All Gemini Launch Vehicle and spacecraft telemetry data acquired by Air Force Eastern Test Range stations are processed in real time at Kennedy Mission Control and forwarded to the Houston MSC Realtime Computer Complex.

For the first time, Kennedy Mission Control will provide a control center position to the Gemini spacecraft checkout team. In the past this has not been possible because of space limitations. The team will be available for spacecraft systems analysis throughout the mission.

#### NASA Communications Network (NASCOM)

This Division, a Goddard responsibility, will establish and operate the world-wide ground communications network that provides teletype, voice, and data links between the stations and control centers for the network.

It links 89 stations, including 34 overseas points, with message, voice and data communications. Its circuits and terminals span 100,000 route miles and 500,000 circuit miles.

For Gemini 4 the Communications Network (NASCOM) will be used in the same basic configuration as for Gemini 3. Several voice and data circuits between Goddard and Houston Mission Control have been added to accommodate the increase in traffic.

During Gemini 3, voice communication with the spacecraft via the Syncom II communications satellite and NASCOM ground stations was successfully achieved over the Indian Ocean. For Gemini 4 a similar exercise is planned using the Syncom III communications satellite stationed over the Pacific Ocean.

Also part of NASCOM is the voice communication net.

A switchboard system, with multiple dual-operating consoles, enables one operator to concentrate on special mission conferences. This system is called SCAMA II (Station Conferencing and Monitoring Arrangement). SCAMA II can now handle 100 lines and can ultimately be expanded to handle 220 lines. Both point-to-point connections and conference arrangements are possible. All lines can be connected into one conference without loss of quality. The SCAMA operator can add conferees or remove them. He also controls which of the conferees can talk and which can listen only.

The SCAMA has 10 times the capability of the network used for Mercury.

Spacecraft Communications

All Manned Space Flight Network stations having both high frequency (HF) and ultra high frequency (UHF) spacecraft communications can be controlled either by the station or remote controlled by Goddard. Houston Mission Control or Kennedy Mission Control.

The following sites will have a Capsule Communicator who will control spacecraft communications at the site: Canary Island; Carnarvon; Kuai, Hawaii; Corpus Christi; Guaymas; Rose Knot; and Coastal Sentry.

The following stations will not have Capsule Communicators and will be remoted to the appropriate Mission Control Center: Grand Bahama Island; Tananarive (Madagascar); Kano, Nigeria; Bermuda; Grand Turk Island; Antigua Island; Ascension Island; Canton Island; Pt. Arguello, Calif.; Range Tracker (ship) and the voice relay aircraft.

Network Responsibility

Goddard Space Flight Center. NASA's Office of Tracking and Data Acquisition has centralized the responsibility for the planning, implementation, and technical operations of manned space flight tracking and data acquisition at Goddard. Technical operation includes operation, maintenance, modification, and augmentation of tracking and data acquisition facilities as an instrumentation network in response to mission requirements. About 370 persons directly support the network at Goddard.

Manned Spacecraft Center. The MSC has the overall management responsibility of the Gemini program. The direction and mission control of the network immediately preceding and during a mission simulation or an actual mission is the responsibility of the MSC.

Weapons Research Establishment. The WRE, Department of Supply, Commonwealth of Australia, is responsible for the maintenance and operation of the network stations in Australia. Contractual arrangements and agreements define this cooperative effort.

Department of Defense. DOD is responsible for the maintenance and operational control of those DOD assets and facilities required to support Gemini. These include network stations at the Eastern Test Range, Western Test Range, the Air Proving Ground Center and the White Sands Missile Test Range.

Gemini 4 Tracking Network Configuration and Station Capability

Stations	Voice Communications	Remote Air to Ground Voice Communications	Air to Ground Voice Communications	Flight Controller Manned	High Speed Radar Data	Telemetry Communications	RF Command	Down Range Up Link	Digital Command System	Gemini Launch Vehicle Command	On Site Data Processor (1218)	Telemetry Real Time Display	Telemetry Receiver & Recorder	Acquisition Aid	C-Band Radar	S-Band Radar
Mission Control Center Merrit Island Launch Area	X		X	X X	X X	X X	X X	X X	X X	X X	X X	X X	X X	X X	X X	
Ascension Island Grand Bahama Island		X	X		X X		X X	X X		X	X X		X X	X X	X X	
Antigua Bermuda					X	X X	X X	X X		X	X X		X X	X X	X X	X
Grand Canary Island Kano, Nigeria			X	X		X X	X		X		X	X	X X	X X	X	X
Tananarive, Madagascar Coastal Sentry, (Quebec)						X X	X		X		X	X	X X	X X		
Carnarvon, Australia Kauai, Hawaii			X	X X		X X	X X		X X		X X	X X	X X	X X	X X	X X
Woomera, Australia Range Tracker (Ship)													X	X		
Canton Island, (Mid Pacific) Rose Knot (Victory)									X		X	X	X X	X X		
Point Arguello, California Guaymas, Mexico			X	X							X	X	X X	X X	X X	X X
White Sands, New Mexico Corpus Christi, Texas				X							X	X	X X	X X		
Eglin Field, Florida Grand Turk Island					X						X		X X	X X	X X	X



### MEDICAL CHECKS

Medical checks will be based on biomedical telemetry and voice communications. This data will be used to evaluate general condition of the crew, blood pressure, and oral temperature.

### Cardiovascular Effects of Space Flight

This is a continuation of experiments during Project Mercury and Gemini 3 to evaluate the effects of prolonged weightlessness on the cardiovascular system. It is considered an operational procedure and no longer an experiment.

Comparisons will be made of the astronaut's preflight and postflight blood pressures, blood volumes, pulse rates, and electrocardiograms. The data will reveal the cardiovascular and blood volume changes due to heat stress, the effect of prolonged confinement, dehydration, fatigue, and possible effects of weightlessness. There are no inflight requirements.

Measurements will be taken before, during, and after a head-up tilt of 80 degrees from the horizontal.

If the astronauts remain in the spacecraft while it is hoisted aboard the recovery vessel, portable biomedical recorder will be attached to each one before he leaves the spacecraft, and blood pressure and electrocardiogram measurements will be taken. Each astronaut then will leave the spacecraft and stand on the ship's deck. Blood pressure and electrocardiogram measurements will be recorded automatically before, during, and for a short time after the crew leaves the spacecraft. The astronauts will then go to the ship's medical facility for the tilt-table tests.

- more -

GEMINI 4 EXPERIMENTS

NASA has scheduled 11 experiments for the Gemini 4 flight. Three of these are medical experiments, four are engineering, two Department of Defense experiments and two scientific.

Medical Experiments

In-flight Exercise: Work Tolerance

The astronauts will use a bungee cord to assess their capacity to do physical work under space flight conditions. The bungee cord requires a 60-pound pull to stretch it to its limit of one foot. The cord will be held by loops about the astronaut's feet rather than being attached to the floor as in Project Mercury tests.

Plans call for each of the Gemini 4 astronauts to make the 60-pound stretch once per second for a minute at various times during the flight. Heart and respiratory rates and blood pressure will be taken before and after the exercise for evaluation. Time for heart rate and blood pressure to return to pre-work levels following the exercise is an index of the general condition of the astronaut.

### In-Flight Phonocardiogram

The purpose of this experiment is to serve as a sensitive indicator of heart muscle deterioration when compared to a simultaneous electrocardiogram. Heart sounds of the Gemini 4 astronauts will be picked up by a microphone on their chests and recorded on the biomedical recorder. This will be compared with the electrocardiogram to determine the time interval between heart contractions.

### Bone Demineralization

X-rays using a special technique (bone densitometry) will be taken before and after the flights. The heel bone and the end bone of the fifth finger on the right hand of each astronaut will be studied to determine whether any demineralization has taken place and, if so, to what extent. The anticipation of possible loss of calcium from the bones during weightless flight is based on years of clinical experience with patients confined to bed or in casts.

The medical experiments are sponsored by the NASA Office of Manned Space Flight's Space Medicine Division.

ENGINEERING EXPERIMENTS

Electrostatic Charge

Objective is to detect and measure any accumulated electrostatic charge on the surface of the Gemini spacecraft. Natural charging mechanisms and charged particles ejected from rocket engines can cause an electrostatic potential, and this must be investigated before rendezvous and docking missions are attempted.

Differences in potential between docking space vehicles can cause an electrical discharge which could damage the vehicle skin and electronic equipment and ignite pyrotechnics aboard the spacecraft. If the spacecraft potential and capacitance is known, it will be possible to calculate the net charge on the spacecraft and the energy available for an electrical discharge between the spacecraft and another space vehicle of known potential.

Any accumulated charge on the surface of the Gemini 4 spacecraft will be measured by an electrostatic potential meter. The experiment will be conducted during all periods of extensive spacecraft attitude maneuvering and during retrofire. Data obtained will be telemetered to ground stations.

The electrostatic potential meter consists of a sensor unit and an electronics unit. Both are located in the spacecraft's adapter section. The sensor unit's face is flush with the outer surface of the spacecraft and obtains electrical signals proportional to the spacecraft potential. The electronics unit processes the information from the sensor and adapts it to the telemetry system. The data obtained is transmitted to ground stations via the spacecraft tape recorder/reproducer system.

The experiment is controlled from the cabin by a switch. Experiment equipment weighs 1.8 pounds. It will be actuated by the pilot, who will record on-off times on the voice recorder.

#### Proton-Electron Spectrometer

The object is to measure the radiation environment immediately outside the spacecraft. The data will be used to correlate radiation measurements made inside the spacecraft and to predict radiation levels on future missions.

The number and energy of the electrons and protons will be measured by a proton-electron spectrometer located in the equipment adapter section. The sensor face will look to the rear of the spacecraft.

The spectrometer will be operated while the spacecraft is passing through the region known as the South Atlantic Geomagnetic Anomaly. It is bounded by 30 degrees east and 60 degrees west longitude, and 15 degrees south and 55 degrees south latitude. This is the region in which the inner Van Allen radiation belt dips close to the Earth's surface because of the irregular strength of the Earth's magnetic field. Data obtained will be telemetered to the ground.

The spectrometer is operated by the pilot by means of a switch. He will record on-off times on the voice recorder. Equipment for the experiment weighs approximately 12.5 pounds.

Tri-Axis Flux-Gate Magnetometer

Objective is to monitor the direction and amplitude of the Earth's magnetic field with respect to the spacecraft. The data will be used to correlate radiation measurements made by the Proton-Electron Spectrometer experiment.

The spectrometer cannot determine the directional distribution of the trapped radiation at spacecraft altitudes. In addition, spacecraft attitude data is not adequate to determine the relative orientation of the Earth's geomagnetic field during drifting flight. Both types of information are necessary to correlate the radiation measurements.

A tri-axis flux-gate magnetometer will be used for this experiment. It consists of an electronics unit and sensors located in the equipment adapter section, with the sensors facing aft. The sensors are on a boom which can be extended beyond the end of the adapter.

The magnetometer will be operated in the same region and at the same time as the spectrometer experiment. The sensors will measure vector components of the magnetic field. By measuring each component, the direction of the field lines can be referenced to the spacecraft and the spectrometer experiment. With field line direction and pitch angle of the



charged particles known, interpolation of data from spectrometer can be related to the total charged particles incident on the spacecraft. Data obtained will be telemetered to the ground.

The pilot operates the experiment with two switches. One switch actuates the boom and is a one-time operation since the boom will not be retracted. The second switch operates both the spectrometer and magnetometer experiments. The magnetometer experiment weighs approximately 3.5 pounds.

The preceding three experiments will be conducted by the Radiation and Fields Branch of the Advanced Spacecraft Technology Division of the Manned Spacecraft Center. It is sponsored by the Office of Manned Space Flight.

#### Two-Color Earth's Limb Photography

Objective is to photograph the Earth's limb in an effort to determine the excess elevation of the blue limb over the red. The limb is the Earth's outer edge of brightness, and this experiment is an extension of the horizon definition experiments begun in Project Mercury.

Postflight measurements of the photographs will be used to determine if the elevation of the Earth's limb can be a reliable aid in future manned space flight guidance and navigation sightings.

The pilot will use a hand-held Hasselblad camera, black and white film, and a special filter mosaic which will allow each picture to be taken partly through a red filter and partly through a blue filter. The modified film magazine has a two-color filter mounted just in front of the film plane. The central portion of each picture will be through the red filter and the side portions through the blue filter.

The experiment will be conducted during the day-side portion of one orbit. As the sunlit Earth's limb becomes visible, the pilot will take three photographs in succession, aiming the camera at the horizon directly in front of the spacecraft along the line-off-flight. In about five minutes, he will again take a group of three pictures. Nine or more such groups may be obtained during the day-side portion of the orbit in which the sunlit limb is visible.

The pilot may perform other tasks between the groups of photographs, but the experiment film magazine must not be removed from the camera and the settings must not be altered. If the experiment is interrupted, the series may be continued in the similar portion of a later day-side orbit, but the film magazine must not be removed until the experiment is completed.

The magazine contains approximately 36 frames, allowing up to nine exposures if the astronauts wish to record an unrelated phenomenon during this experiment.

The experiment does not require attitude maneuvering other than to orient the spacecraft along the orbital track while each series of photographs is being taken.

The experimental film magazine weighs approximately one pound.

The experiment will be conducted by the Instrumentation Laboratory, Department of Aeronautics and Astronautics, Massachusetts Institute of Technology, Cambridge. Sponsor is the Office of Manned Space Flight.

SCIENTIFIC EXPERIMENTS

Synoptic Terrain Photography Experiment

Primary objective is to get high-quality pictures of large land areas that have been previously well-mapped by aerial photography. Such photographs can serve as a standard for interpretation of pictures of unknown areas on Earth, the Moon, and other planets.

A secondary objective is to obtain high-quality pictures of relatively poorly-mapped areas of the Earth for specific scientific purposes. For example, geologists hope that such photographs can help to answer questions of continental drift, structure of the Earth's mantle, and overall structure of the continents.

The continental United States will be the priority photographic objective, followed by the Arabian Peninsula and East Africa, and third, other parts of Africa. Of particular interest are rift valleys which are geologically analogous to the rills found on the Moon. These rift valleys extend from Turkey, through Syria, Jordan, the Red Sea area and eastern Africa as far south as Mozambique. By photographing these rift valleys, geologists feel that may gain a better understanding

of the crust and upper mantle of the Earth as well as the rills on the Moon.

Additionally, this area particularly in the Sahara desert, has many wind-blown sand dunes, called seif dunes, which are several hundred feet high and extend many hundreds of miles in length. There has been some scientific speculation that the familiar canals on Mars may be a type of seif, or sand dunes. Photographs of these dunes from the Gemini 4 flight are expected to allow scientists to better interpret photographs from the upcoming (July 14, 1965) Mariner IV fly-by of Mars. Additionally, it should result in better interpretation of photographs taken of Mars by Earth-based telescopes.

Photography will be performed during periods of maximum daylight, from 9 A.M. to 3 P.M. local time. If cloud cover is over 50 per cent in the priority areas, the astronauts will photograph subjects of opportunity--any interesting land areas.

A 70-mm modified Hasselblad (Swedish make), Model 500C will be used. The magazine capacity of this camera is 55 frames per roll. The nose of the Gemini 4 spacecraft will be tilted straight down. Normally, the camera will be in use from five to 10 minutes, taking a photograph every six seconds of a 100-mile-wide area, thus giving continent-wide coverage when the individual frames are mounted as a continuous photographic strip.

Space photography, in comparison with aerial photography, is thought to have the advantage of providing greater perspective, wider coverage, greater speed, and rapid repetition of coverage. These factors suggest applications in many areas of geology, weather, topography, hydrology and oceanography.

For example:

1. Geologic reconnaissance can tell us more of our own planet, leading to better interpretation of the geology of the Moon and other planets.

2. Topographic mapping of Earth can give us newer and better maps with a scale of 1:1,000,000.

3. Hydrology mapping could, for example, permit estimates of the amount of snowfall in particular regions and what the amount of run-off would be in the springtime, of great interest in flood prevention and control.

4. Oceanographic mapping could, among other things, show the distribution and temperature of ocean currents; the location of ice of danger to shipping.

Space photography also shows potential for forestry mapping, for example, noting vegetation changes. It also can supplement the TV-type photography of our weather satellites since film provides greater resolution.

The experiment is being conducted by Dr. Paul D. Lowman, Jr., a geologist at NASA's Goddard Space Flight Center, Greenbelt, Md.

Synoptic Weather Photography Experiment

The Synoptic Weather Photography experiment is designed to make use of man's ability to photograph cloud systems selectively--in color and in greater detail than can be obtained from the current TIROS meteorological satellite.

The Gemini 4 crew will photograph various cloud systems. They will be using the same 70-mm Hasselblad camera and Ektachrome film as for the Synoptic Terrain Photography experiment.

A primary purpose of the experiment is to augment information from meteorological satellites. Observations from meteorological satellites are contributing substantially to knowledge of the Earth's weather systems. In many areas they provide information where few or no other observations exist. Such pictures, however, are essentially television views of large areas taken from an altitude of 400 miles or more. They lack the detail which can be obtained in photographs taken from the Gemini height of about 100 miles.

One of the aims of the S-6 experiment in the Gemini 4 and subsequent flights is to get a better look at some of the cloud patterns seen on TIROS pictures, but not fully understood. There are cellular patterns, cloud bands radiating from a point, apparent shadows of indistinguishable high clouds on low cloud decks, and small vortices sometimes found in the lee of mountainous islands.

Another objective is to get pictures of a variety of storm systems, such as weather fronts, squall lines, or tropical disturbances, so that their structure can be better understood.

Finally, the experimenters hope to get several sets of views of the same area on subsequent passes of the spacecraft to see how various weather phenomena move and develop.

The experimenters are Kenneth M. Nagler and Stanley D. Soules, both of the Weather Bureau's National Weather Satellite Center. Nagler has a dual role in the Gemini 4 spaceflight, serving both as an experimenter in the weather photography effort and as Head of the Spaceflight Meteorology Group which provides NASA the forecasting support for its manned spaceflight programs. Soules is with the Meteorological Satellite Laboratory. He previously



prepared photographic experiments conducted by Astronauts Schirra and Cooper in their Mercury flights. In these the Earth and its cloud systems were viewed in different portions of the visual and infrared spectra. The experiment monitor is Capt. Robert D. Mercer, USAF, assigned to the NASA Manned Spacecraft Center.

- more -

FOOD FOR GEMINI 4

The meals planned for the Gemini 4 crew contain 49 different items. There are some differences in the menus for each astronaut, based on individual preferences, but the calorie balance is the same.

The astronauts will eat four meals a day. The meals are stored in 18 packages, 14 two-man meals and four one-man meals, in a compartment above the command pilot's left shoulder. They are marked by day and meal and are placed in the compartment in order so that the first day meal is on top. The packages are connected by a nylon lanyard which prevents them from getting out of order when floating inside the compartment.

The food consists of freeze-dried items, dehydrated items in powder form and compressed bite-sized items. The dehydrated food and some of the freeze dried items will be reconstituted by adding water with a special water gun. The compressed items do not need water.

Each package of freeze-dried food contains a disinfectant tablet which is placed in the food pouch after the astronaut has eaten. The tablet acts chemically to prevent spoilage of the remaining food.

The food formulation concept was developed by the U.S. Army Laboratories, Natick, Mass. Overall food procurement, processing, and packaging was performed by the Whirlpool Corp., St. Joseph, Mich. Principal food contractors are Swift and Co., Chicago, and Pillsbury Co., Minneapolis.

GEMINI 4 MENU

First Day

McDivitt

White

	Calories
<u>MEAL A</u>	
(R) All Star Cereal	91
(B) Bacon & Egg Bites	283
(B) Toasted Bread Cubes	165
(R) Orange Juice	83
	<u>622</u>
<u>MEAL B</u>	
(R) Beef & Gravy	148
(R) Corn	105
(B) Toast	78
(B) Fruitcake (Date)	202
(R) Tea	32
	<u>565</u>
<u>MEAL C</u>	
(R) Pea Soup	220
(R) Salmon Salad	238
(B) Toast	78
(R) Fruit Cocktail	86
(R) Orange Juice	83
	<u>705</u>
<u>MEAL D</u>	
(R) Orange-Grapefruit Jc.	83
(B) Chicken Sandwich	184
(R) Chocolate Pudding	156
(B) Peanut Cubes	296
	<u>719</u>
Total Calories	2611
Food Only Weight	549.8 gm

	Calories
<u>MEAL A</u>	
(R) All Star Cereal	91
(B) Bacon & Egg Bites	283
(B) Toasted Bread Cubes	165
(R) Orange Juice	83
	<u>622</u>
<u>MEAL B</u>	
(R) Beef & Gravy	148
(R) Corn	105
(B) Toast	78
(B) Fruitcake (Date)	202
(R) Tea	32
	<u>565</u>
<u>MEAL C</u>	
(R) Pea Soup	220
(R) Chicken Salad	237
(B) Toast	78
(R) Fruit Cocktail	86
(R) Orange Juice	83
	<u>704</u>
<u>MEAL D</u>	
(R) Orange-Grapefruit Jc.	83
(B) Chicken Sandwich	184
(R) Chocolate Pudding	156
(B) Peanut Cubes	296
	<u>719</u>
Total Calories	2610
Food Only Weight	550.8 gm

(R) Reconstituted with water  
 (B) Bite size, no water added

1 ounce (avoirdupois) equals  
 28.3 grams  
 1 gram equals .035 ounce

NOTE: The same menu will be used by the back-up crew, if necessary.

Second Day

McDivitt

White

	Calories
(B) Apricot Cereal Bars	154
(R) Ham & Applesauce	127
(B) Cinnamon Toast	76
(R) Cocoa	186
	<u>543</u>
<hr/>	
(B) Beef Bites	167
(R) Potato Salad	145
(B) Fruitcake (Pineapple)	211
(R) Orange Juice	83
	<u>606</u>
<hr/>	
(R) Banana Pudding	141
(R) Chicken Salad	237
(R) Peaches	68
(B) Beef Sandwiches	202
	<u>648</u>
<hr/>	
(R) Potato Soup	222
(R) Chicken & Gravy	91
(B) Toast	78
(B) Peanut Cubes	296
(R) Tea	32
	<u>719</u>
<hr/>	
Total Calories	2516
Food Only Weight	521.8 gm

	Calories
(B) Apricot Cereal Bars	154
(R) Ham & Applesauce	127
(B) Cinnamon Toast	76
(R) Cocoa	186
	<u>543</u>
<hr/>	
(B) Beef Bites	167
(R) Potato Salad	145
(B) Fruitcake (Pineapple)	211
(R) Orange Juice	83
	<u>606</u>
<hr/>	
(R) Banana Pudding	141
(R) Chicken Salad	237
(R) Peaches	68
(B) Beef Sandwiches	202
	<u>648</u>
<hr/>	
(R) Potato Soup	202
(R) Chicken & Gravy	91
(B) Toast	78
(B) Coconut Cubes	296
(R) Tea	32
	<u>719</u>
<hr/>	
Total Calories	2516
Food Only Weight	521.8 gm

(R) Reconstituted with water

(B) Bite size, no water added

1 ounce (avoirdupois) equals 28.3 grams

1 gram equals .035 ounce

Third Day

McDivitt

White

	Calories
(R) Sugar Frosted Flakes	139
(B) Bacon Squares(Dbl.Serv)	203
(B) Cinnamon Toast	76
(R) Orange-Grapefruit Jc.	83
	<u>501</u>
(R) Tuna Salad	204
(B) Cheese Sandwich	231
(R) Apricot Pudding	147
(R) Orange Juice	83
	<u>665</u>
(R) Beef Pot Roast	116
(R) Green Peas	74
(B) Toasted Bread Cubes	165
(B) Pineapple Cubes	283
(R) Tea	32
	<u>670</u>
(B) Chicken Bites	163
(B) Toast	78
(R) Applesauce	165
(B) Brownies	249
(R) Grapefruit Juice	83
	<u>738</u>
Total Calories	2574
Food Only Weight	542.9 gm

	Calories
(R) Sugar Frosted Flakes	139
(R) Sausage Patties	202
(B) Cinnamon Toast	78
(R) Orange-Grapefruit Jc.	83
	<u>502</u>
(R) Beef & Gravy	148
(B) Cheese Sandwich	231
(R) Apricot Pudding	147
(R) Orange Juice	83
	<u>609</u>
(R) Beef Pot Roast	116
(R) Green Peas	74
(B) Toasted Bread Cubes	165
(B) Pineapple Cubes	283
(R) Tea	32
	<u>670</u>
(B) Chicken Bites	163
(B) Toast	78
(R) Applesauce	165
(B) Brownies	249
(R) Grapefruit Juice	83
	<u>738</u>
Total Calories	2519
Food Only Weight	537.9 gm

(R) Reconstituted with water

(B) Bite size, no water added

1 ounce (avoirdupois) equals 28.3 grams

1 gram equals .035 ounce

Fourth Day

McDivitt

White

	Calories
(B) Strawberry Cereal Bars	156
(B) Bacon Squares	102
(R) Orange Juice	83
(B) Beef Sandwiches	202
	<u>543</u>

	Calories
(B) Strawberry Cereal Bars	156
(B) Bacon Squares	102
(R) Orange Juice	83
(B) Beef Sandwiches	202
	<u>543</u>

(R) Corn Chowder	252
(B) Beef Sandwich	202
(B) Gingerbread	183
(R) Chocolate Pudding	156
	<u>793</u>

(R) Corn Chowder	252
(B) Beef Sandwich	202
(B) Gingerbread	183
(R) Pudding, Chocolate	156
	<u>793</u>

(R) Shrimp Cocktail	113
(R) Chicken & Vegetables	80
(B) Toasted Bread Cubes	165
(R) Butterscotch Pudding	154
(R) Orange-Grapefruit Jc.	83
	<u>595</u>

(R) Beef Pot Roast	116
(R) Chicken & Vegetables	80
(B) Toasted Bread Cubes	165
(R) Butterscotch Pudding	154
(R) Orange-Grapefruit Jc.	83
	<u>598</u>

(R) Beef w/Vegetables	85
(R) Shrimp	113
(B) Toast	78
(B) Apricot Cubes	281
(R) Tea	32
	<u>589</u>

(R) Beef w/Vegetables	83
(R) Spaghetti & Meat Sauce	91
(B) Toast	78
(B) Apricot Cubes	281
(R) Tea	32
	<u>567</u>

Total Calories 2520  
Food Only Weight 542.5 gm

Total Calories 2501  
Food Only Weight 532.5 gm

(R) Reconstituted with water

(B) Bite size, no water added

1 ounce (avoirdupois) equals 28.3 grams

1 gram equals .035 ounce

## GEMINI SPACECRAFT

The Gemini spacecraft is conical 18 feet, 5 inches long, 10 feet across at the base and 39 inches across at the top. It has two major sections, the reentry module and the adapter section.

### Reentry Module

The reentry module is 11 feet high and  $7\frac{1}{2}$  feet in diameter at its base. It has three primary sections: (1) rendezvous and recovery section (R&R); (2) reentry control section (RCS); (3) cabin section.

The rendezvous and recovery section is the forward (small) portion of the spacecraft. Housed in this section are the drogue, pilot and main parachutes and the rendezvous radar. However, the rendezvous radar will not be carried on Gemini 4.

The reentry control system is located between the rendezvous and recovery section and the cabin section. It contains fuel and oxidizer tanks, valves, tubing and thrust chamber assemblies (TCA). A parachute adapter assembly is on the forward face for the main parachute attachment.



The cabin section is located between the reentry control section and the adapter section. It houses the crew seated side-by-side, electrical and life support equipment and experimental devices. Above each seat is a hatch opening for entering and leaving the cabin. The crew compartment is pressurized and spaces containing equipment that require no pressurization or which are internally pressurized are located between the pressurized section and the outer shell. The outer shell is covered with overlapping shingles to provide aerodynamic and heat protection. A dish-shaped heat shield forms the large end of the cabin section and reentry module.

#### Adapter Section

The adapter is  $7\frac{1}{2}$  feet high and 10 feet in diameter at the base. It consists of a retrograde section and an equipment section.

The retrograde section contains retrograde rockets and part of the radiator for the cooling system.

# LIQUID ROCKET SYSTEMS GENERAL ARRANGEMENT

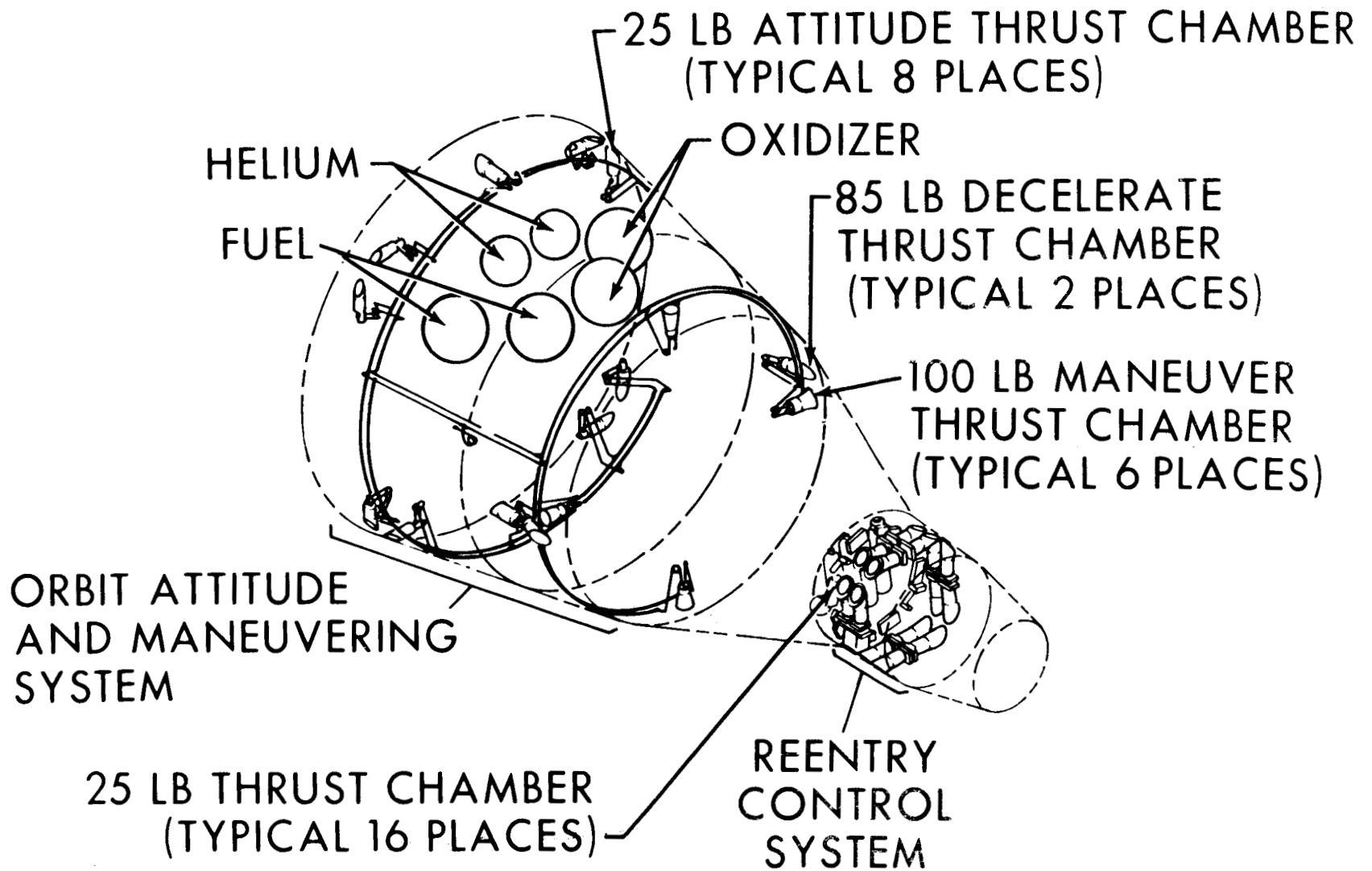

# THRUST CHAMBER ARRANGEMENT

ATTITUDE CONTROL  
25 LBS. THRUST PER UNIT

MANEUVER CONTROL  
100 LBS. THRUST PER UNIT  
\* 85 LBS. THRUST PER UNIT AFT

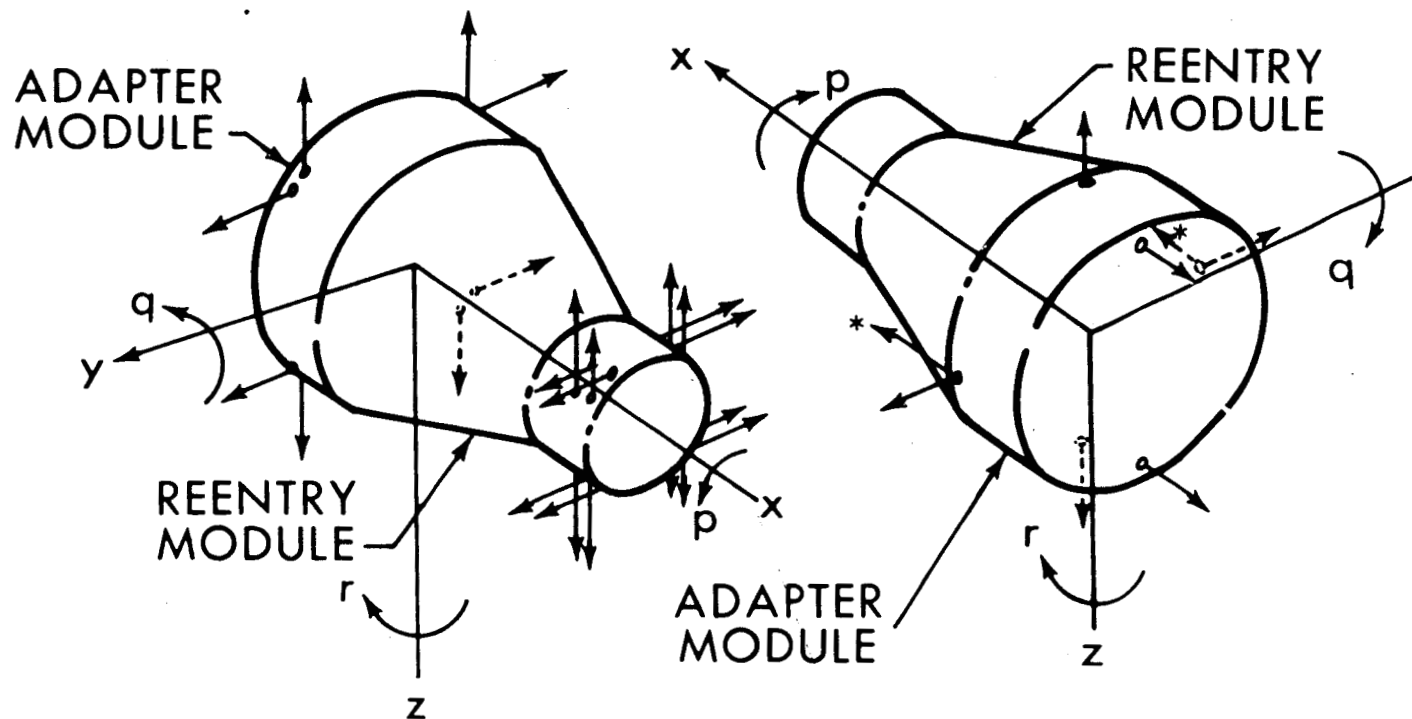

# MANEUVERING CONTROL

VERTICAL

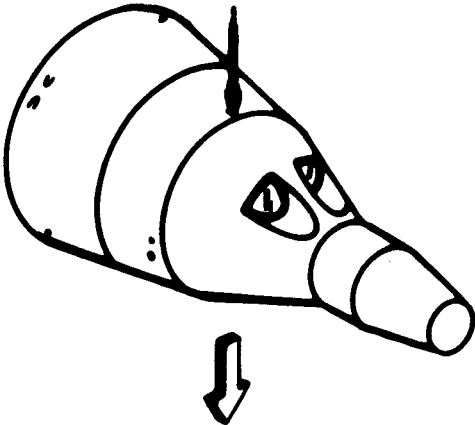

FORWARD

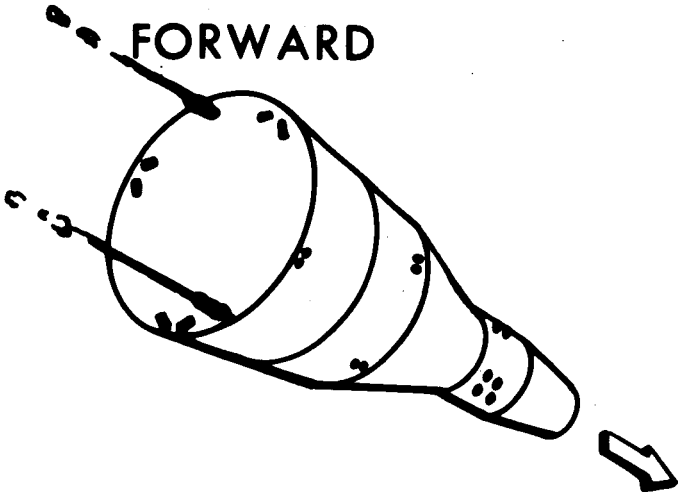

LATERAL

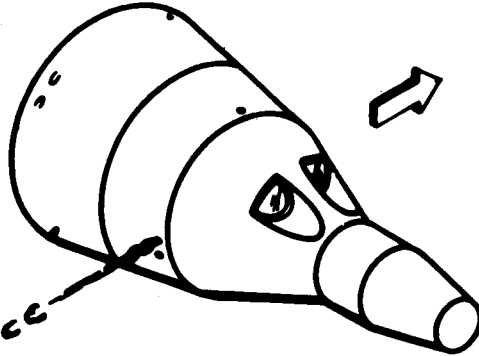

AFT

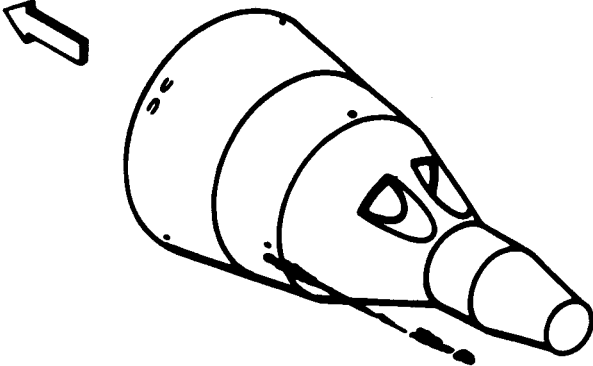

# SPACECRAFT RESPONSES TO ORBIT ATTITUDE CONTROL THRUST

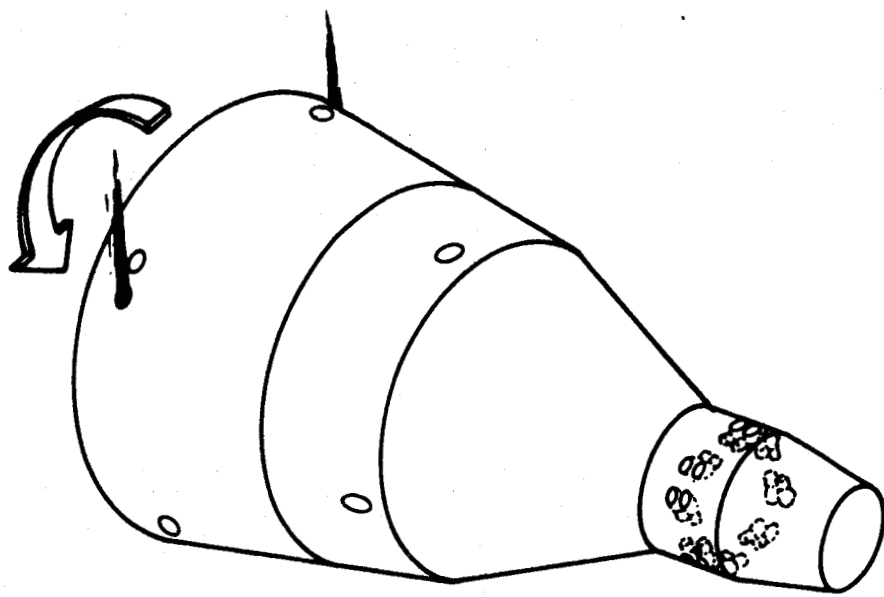

PITCH

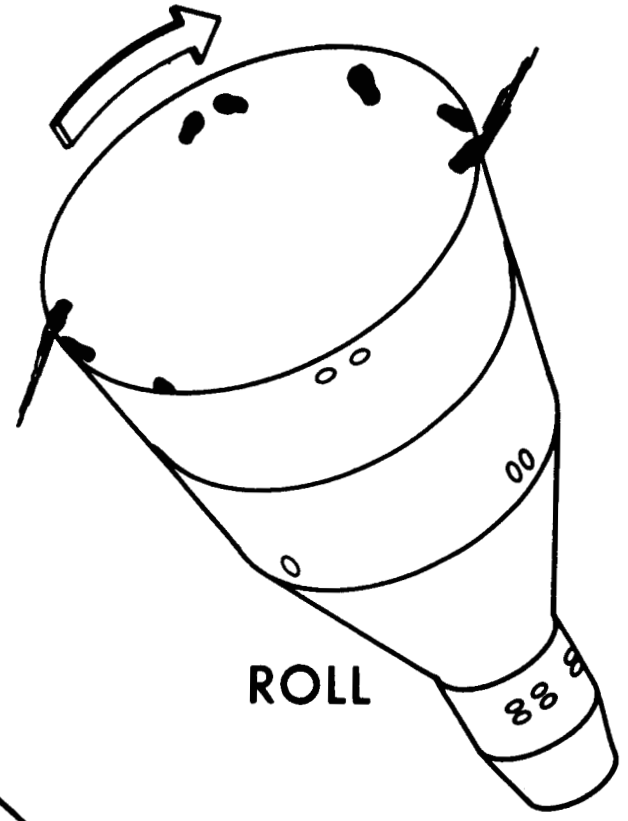

ROLL

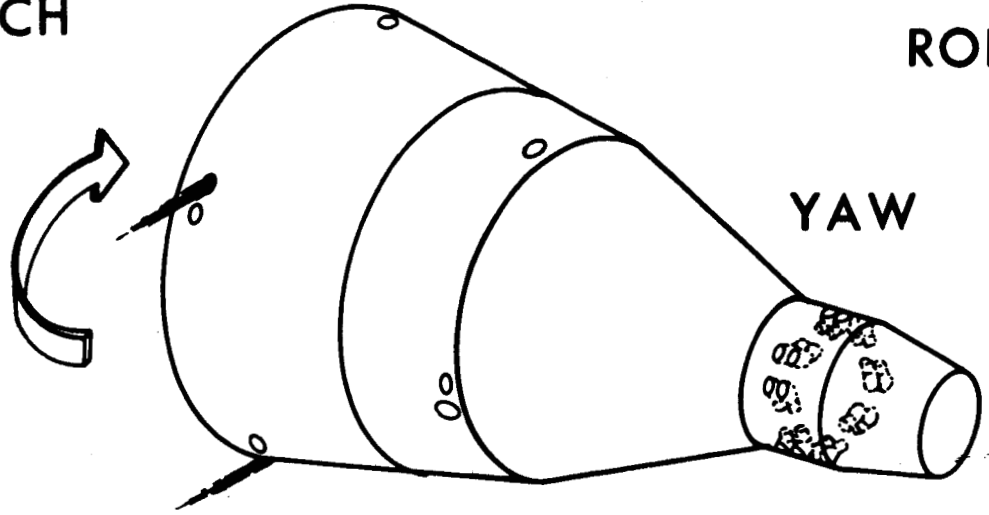

YAW

# RCS FUNCTION

RE-ENTRY  
MODULE

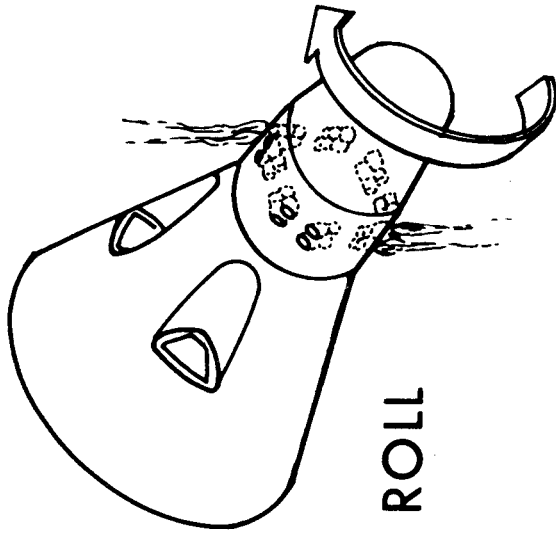

ROLL

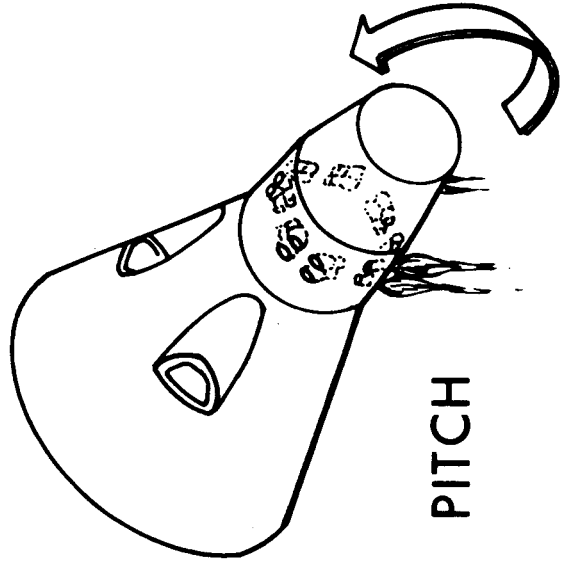

PITCH

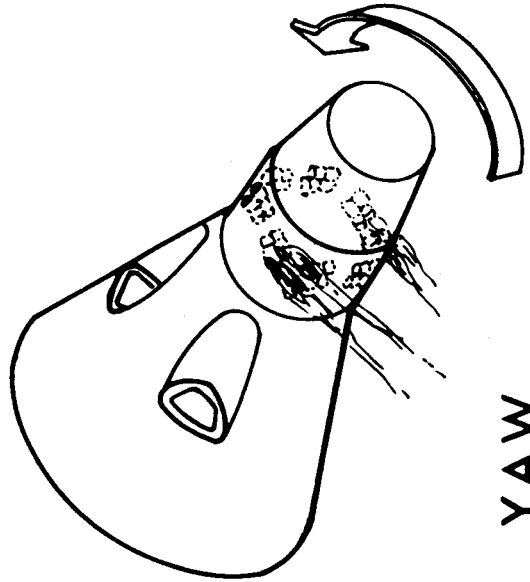

YAW

The equipment section holds batteries for electrical power, fuel for the orbit attitude and maneuver system (OAMS), the primary oxygen for the environmental control system. It also serves as a radiator for the spacecraft's cooling system which is contained in the section. The equipment section is jettisoned immediately before the retrorockets are fired for reentry and the retrograde section is jettisoned after the retrorockets are fired.

The Gemini spacecraft weighs approximately 7,000 pounds at launch. The reentry module weighs about 4,700 pounds when it lands.

McDonnell Aircraft Corp., St Louis, is prime contractor for the Gemini spacecraft.

GEMINI LAUNCH VEHICLE

The Gemini Launch Vehicle is a modified U.S. Air Force Titan II intercontinental ballistic missile consisting of two stages.

The first stage is 63 feet high and the second stage is 27 feet high. Diameter of both stages is 10 feet. Overall height of the launch vehicle plus the spacecraft is 109 feet. Launch weight including the spacecraft is about 340,000 pounds.

The first stage has two rocket engines and the second stage has a single engine. All engines burn a 50-50 blend of monomethyl hydrazine and unsymmetrical-dimethyl hydrazine as fuel with nitrogen tetroxide as oxidizer. The fuel is hypergolic, that is it ignites spontaneously when it comes in contact with the oxidizer, and is storable.

The first stage engines produce a combined 430,000 pounds of thrust at lift-off and the second stage engine produces about 100,000 pounds thrust at altitude.

Titan II was chosen for the Gemini program because of its simplified operation, thrust and availability. The following modifications were made in the Titan II to make it suitable for manned space flight launches:



1. Addition of a malfunction detection system to detect and transmit information of problems in the booster system to the crew.

2. Modification of the flight control system to provide a back-up system should the primary system fail in flight.

3. Modification of the electrical system.

4. Substitution of radio guidance for inertial guidance.

5. Deletion of retro rockets and vernier rockets.

6. New second stage equipment truss.

7. New second stage forward oxidizer skirt assembly.

8. Simplification of trajectory tracking requirements.

9. Modification of hydraulic system.

10. Modification of instrument system.

Gemini Launch Vehicle program management for NASA is under the direction of the Space Systems Division of the Air Force Systems Command. Contractors include:

Air Frame and system integration, Martin Co., Baltimore Divisions, Baltimore.

Propulsion systems, Aerojet-General Corp., Sacramento, Calif.

Radio command guidance system, General Electric Co., Syracuse, N.Y.

Ground guidance computer, Burroughs Corp., Paoli, Pa.

Systems engineering and technical direction, Aerospace Corp., El Segundo, Calif.

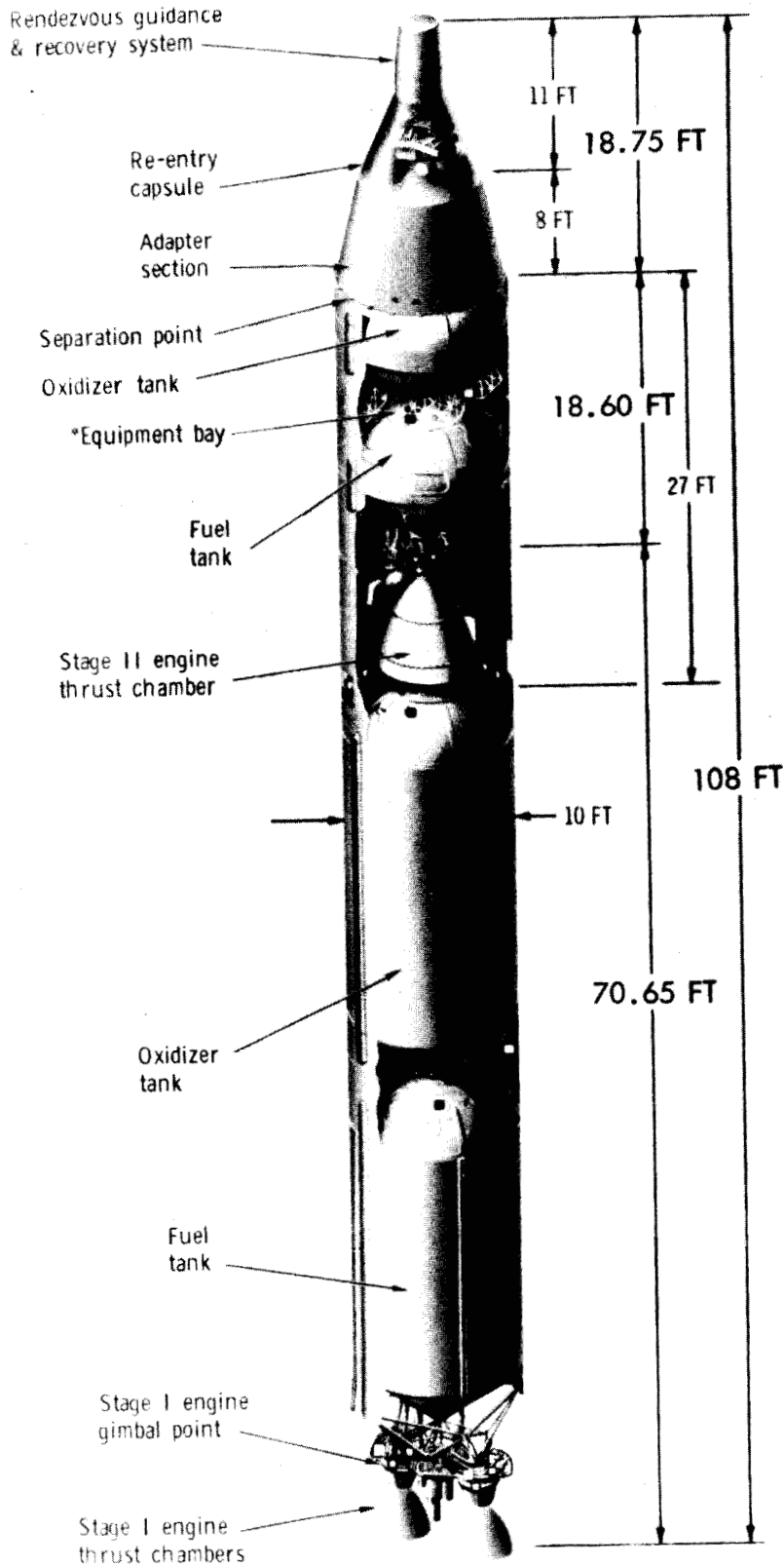

\*Equipment bay contains:

- Batteries
- Malfunction detection system (MDS) units
- Range safety command control system
- Programmer
- Three-axis reference system (TARS)
- Radio guidance system (RGS)
- Autopilot
- Instrumentation and telemetry system

GEMINI SPACE SUIT

Gemini extravehicular suit will be worn by the Gemini 4 crew to evaluate and flight-qualify it. This is the suit planned for activity outside the spacecraft.

The extravehicular suit differs from the regular Gemini space suit in three ways:

1. An extra layer for thermal and micrometeoroid protection has been added to the basic suit. It is an integral part of the suit. The extra layer weighs about 3 3/4 pounds and is white, the same color as the basic suit. It is made of a cover layer of high temperature nylon and layers of aluminized mylar and felt.

2. Two external visors have been added to the helmet. The inner visor is made of a material called Lexan, which is about 30 times stronger than the plastic used in aircraft canopies. It is coated with a special solution which prevents heat leak from the suit into a vacuum. This visor provides micrometeoroid and thermal protection for the faceplate. The outer visor is tinted and provides glare protection for the astronaut.

3. A strain relief zipper has been added beneath the pressure sealing zipper of the suit. The new zipper is designed to take the strain from the pressure sealing zipper during opening and closing of the suit.

The basic Gemini suit is a close fitting full pressure suit with an inner layer of a rubberized material covered by a nylon material. The helmet and gloves may be removed in flight.

Oxygen inlet and outlet connections are located at waist level. The suit is entered through a zipper opening which runs from the crotch up the entire back of the suit.

A small battery pack and individual fingertip lights are mounted on each glove so that the astronauts can read instruments on the night side of the Earth while the cabin light is off.

The suit has been developed by MSC's Crew Systems Division. Prime contractor is the David Clark Co., Worcester, Mass.

CREW BIOGRAPHIES

James A. (for Alton) McDivitt, Gemini 4 command pilot

Born: Chicago, June 10, 1929

HEIGHT: 5ft. 11 in., WEIGHT: 155 lbs; Brown hair, blue eyes.

EDUCATION: Bachelor of Science degree in aeronautical engineering from the University of Michigan 1959 (graduated first in class). Attended Jackson Junior College, 1948-1950.

MARITAL STATUS: Married to the former Patricia Ann Haas of Cleveland, Ohio

CHILDREN: Michael A., Apr. 16, 1957; Ann Lynn, July 21, 1958; Patric W., Aug. 30, 1960

PROFESSIONAL ORGANIZATIONS: Member, Society of Experimental Test Pilots and American Institute of Aeronautics and Astronautics

EXPERIENCE: McDivitt, an Air Force Major, joined the Air Force in 1951. He flew 145 combat missions during the Korean action in F-80's and F-86's. He was awarded three Distinguished Flying Crosses, five Air Medals, and the Choo Moo Medal from South Korea.

He is a graduate of the USAF Experimental Test Pilot School and the USAF Aerospace Research Pilot course. He served at Edwards Air Force Base, Calif., as an experimental test pilot.

McDivitt has logged more than 3,000 hours flying time, including 2,500 hours in jet aircraft.

CURRENT ASSIGNMENT: McDivitt was selected as an astronaut by NASA in September 1962. In addition to participating in the overall astronaut training program he has had additional specialized duties. These duties include monitoring the design and development of the guidance and navigation systems for the Gemini and Apollo spacecraft, as well as monitoring the overall Apollo Command and Service Modules.

McDivitt is son of Mr. & Mrs. James McDivitt, Jackson, Mich.

Edward H. (for Higgins) White II, Gemini 4 pilot

**BORN:** San Antonio, Tex., Nov. 14, 1930

**HEIGHT:** 6 ft.; **WEIGHT:** 171 lbs.; **Brown hair,**  
**Brown eyes**

**EDUCATION:** Bachelor of Science degree from United States Military Academy, 1952, Master of Science degree in aeronautical engineering, University of Michigan, 1959

**MARITAL STATUS:** Married to former Patricia Eileen Finegan of Washington, D.C.

**CHILDREN:** Edward, May 15, 1953; Bonnie Lynn, Sept. 15, 1956

**PROFESSIONAL ORGANIZATIONS:** Associate member of Institute of Aero-space Sciences; Member of Sigma Delta Psi, athletic honorary; and Member of Tau Beta Pi, engineering honorary

**EXPERIENCE:** White, an Air Force Major, received flight training in Florida and Texas, following his graduation from West Point. He spent 3½ years in Germany with a fighter squadron, flying F-86's and F-100's.

He attended the Air Force Test Pilot School at Edwards Air Force Base, Calif., in 1959.

White was later assigned to Wright-Patterson Air Force Base, Ohio, as an experimental test pilot with the Aeronautical Systems Division. In this assignment he made flight tests for research and weapons systems development, wrote technical engineering reports, and made recommendations for improvement in aircraft design and construction.

He has logged more than 3,600 hours flying time, including more than 2,200 hours in jet aircraft.

**CURRENT ASSIGNMENT:** White is a member of the astronaut team selected by NASA in September 1962.

White is the son of Maj. Gen. and Mrs. Edward H. White, St. Petersburg, Fla.

Frank Borman, Gemini 4 back-up crew, Command Pilot

BORN: Gary, Ind., Mar. 14, 1928

HEIGHT: 5 ft., 10 in.; WEIGHT: 163 lbs.; Blonde hair, blue eyes

EDUCATION: Bachelor of Science degree, United States Military Academy, 1950; Master of Science degree in aeronautical engineering, California Institute of Technology, 1957.

MARITAL STATUS: Married to the former Susan Bugbee of Tucson, Ariz.

CHILDREN: Frederick, Oct. 4, 1951; Edwin, July 20, 1953

EXPERIENCE: Upon graduation from West Point, Borman, now an Air Force Major, chose an Air Force Career and received his pilot training at Williams Air Force Base, Calif.

From 1951 to 1956 he served with fighter squadrons in the United States and in the Philippines and was an instructor at the Air Force Fighter Weapons School.

From 1957 to 1960 he was an instructor of thermodynamics and fluid mechanics at the U.S. Military Academy.

He was graduated from the USAF Aerospace Research Pilots School in 1960 and later served there as an instructor. In this capacity he prepared and delivered academic lectures and simulator briefings, and flight test briefings on the theory and practice of spacecraft testing.

Borman has logged more than 4,400 hours flying time, including more than 3,600 hours in jet aircraft.

CURRENT ASSIGNMENT: Borman was one of the nine astronauts named by NASA in September 1962.

Borman is the son of Mr. & Mrs. Edwin Borman, Phoenix, Ariz.



James A. (for Arthur) Lovell, Jr., Gemini 4 back-up crew pilot

BORN: Cleveland, Ohio, March 25, 1928

HEIGHT: 6 ft. ; WEIGHT: 165 lbs. ; Blond hair, blue eyes

EDUCATION: Bachelor of Science degree from the United States Naval Academy, 1952; attended University of Wisconsin, 1946-1948.

MARITAL STATUS: Married to the former Marilyn Gerlach of Milwaukee

CHILDREN: Barbara Lynn, Oct. 13, 1953; James A., Feb. 15, 1955; Susan Kay, July 14, 1958

EXPERIENCE: Lovell, a Navy Lieutenant Commander, received flight training following his graduation from Annapolis.

He served in a number of Naval aviator assignments including a three-year tour as a test pilot at the Naval Air Test Center at Patuxent River, Md. His duties there included service as program manager for the F4H Weapon System Evaluation.

Lovell was graduated from the Aviation Safety School of the University of Southern California.

He served as flight instructor and safety officer with Fighter Squadron 101 at the Naval Air Station at Oceana, Va.

Lovell has logged 3,000 hours flying time, including more than 2,000 hours in jet aircraft.

CURRENT ASSIGNMENT: Lovell was selected as an astronaut by NASA in September 1962. In addition to participating in the overall astronaut training program, he has been assigned special duties monitoring design and development of recovery and including crew life support systems and developing techniques for lunar and earth landings and recovery.

Lovell is the son of Mr. & Mrs. James A. Lovell, Sr., Edgewater Beach, Fla.

PROJECT OFFICIALS

George E. Mueller	Associate Administrator, Office of Manned Space Flight, NASA Headquarters. Acting Director, Gemini Program.
William C. Schneider	Deputy Director, Gemini Program, Office of Manned Space Flight, NASA Headquar- ters.
E. E. Christensen	Director, Missions Opera- tions, NASA Headquarters
Charles W. Mathews	Gemini Program Manager, Manned Spacecraft Center, Houston
Christopher C. Kraft	Mission Director, Manned Spacecraft Center, Houston
Lt. Gen. Leighton I. Davis	USAF, National Range Division Commander and DOD Manager of Manned Space Flight Support Opera- tions.
Maj. Gen. V. G. Huston	USAF, Deputy DOD Manager
Col. Richard C. Dineen	Director, Directorate Gemini Launch Vehicles, Space Systems Division, Air Force Systems Command.
Lt. Col. John G. Albert	Chief, Gemini Launch Division, 6555th Aerospace Test Wing, Air Force Missile Test Center, Cape Kennedy, Fla.
R. Admiral B. W. Sarver	USN, Commander Task Force 140.

PREVIOUS GEMINI FLIGHTS

Gemini 1, April 8, 1964

This was an unmanned orbital flight to test the Gemini launch vehicle performance and the ability of the spacecraft and launch vehicle to withstand the launch environment. The first production Gemini spacecraft was used. It was equipped with instrumentation designed to obtain data on exit heating, structural loads, temperatures, vibrations and pressures. The launch vehicle was essentially the same configuration as will be flown on all Gemini missions.

Primary objectives of Gemini 1, all successfully accomplished:

1. Demonstrate and qualify Gemini launch vehicle performance.
2. Determine exit heating conditions on the spacecraft and launch vehicle.
3. Demonstrate compatibility of the launch vehicle and spacecraft through orbital insertion.
4. Demonstrate orbital insertion.

The combined spacecraft and launch vehicle second stage orbited for about four days. Recovery was not attempted.

Gemini 2, Jan. 19, 1965

This was an unmanned ballistic flight to qualify spacecraft reentry heat protection and test the major Gemini systems required for manned orbital flights.

Primary objectives of Gemini 2, all successfully accomplished:

1. Demonstrate the adequacy of the spacecraft afterbody heat protection during a maximum heating rate reentry.
2. Demonstrate spacecraft separation from the launch vehicle and separation of the equipment and retrograde sections.
3. Qualify all spacecraft and launch vehicle systems as required for manned orbital flights.
4. Demonstrate combined spacecraft and launch vehicle checkout and launch procedures.
5. Demonstrate spacecraft recovery systems and recover the spacecraft.

The Gemini 2 flight was delayed three times by adverse weather--damage to the electrical systems by lightning in August 1964, by Hurricanes Cleo and Dora in September. In December the attempted launch was terminated because of a hydraulic component failure. The vehicle had shifted to the

back-up hydraulic system but the man-rating capability of the launch vehicle prohibits liftoff when the vehicle is operating on a back-up system.

Gemini 3, March 23, 1965

This was the first manned flight. Astronauts Virgil I. Grissom and John W. Young made three orbits of the Earth in four hours and 53 minutes. The spacecraft landed about 50 miles short of the planned landing area in the Atlantic Ocean because the spacecraft did not provide as much lift as expected during the re-entry and landing phase.

Objectives of the Gemini 3 mission:

1. Demonstrate manned orbital flight in the Gemini spacecraft and qualify it for long-duration missions.
2. Evaluate the Gemini design and its effects on crew performance capabilities for the mission period.
3. Exercise the orbital orientation and maneuvering system.
4. Evaluate controlled flight path reentry by controlling the spacecraft roll and utilizing the force resulting from an offset in the spacecraft center of gravity.
5. Conduct experiments.

ORBITS - REVOLUTIONS

During long-duration Gemini flights the spacecraft's course in space may be measured in either orbits or revolutions. Orbits are space referenced and take into account Earth rotation.

Gemini 4 is a planned 97-hour-and-fifty-minute flight. The planned orbital period is about 90 minutes or 16 orbits every 24 hours.

Revolutions will be measured each time Gemini 4 passes over 80 degrees west longitude, about once every 96 minutes.

This method of measurement results in about 15 revolutions per day, or less revolution than orbits.

The longer time for revolutions is caused by the rotation of the Earth. As the spacecraft orbits, the Earth turns underneath it so that on each ascending pass across the equator the spacecraft regresses about 22.5 degrees, about six minutes in time.