

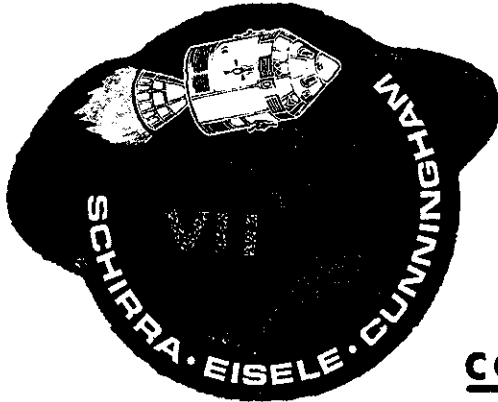

FOR RELEASE: SUNDAY  
October 6, 1968

RELEASE NO: 68-168K



PROJECT: APOLLO 7

contents

GENERAL RELEASE-----1-5

MISSION OBJECTIVES-----6-7

MISSION DESCRIPTION-----8-14

FLIGHT PLAN-----15-18

ALTERNATE MISSIONS-----19-22

EXPERIMENTS-----23

ABORT MODES-----24

SPACECRAFT STRUCTURE SYSTEMS-----25-30

THE SATURN 1B LAUNCH VEHICLE-----31-34

FLIGHT SEQUENCE-----35-36

LAUNCH PREPARATIONS-----37-40

LAUNCH COMPLEX 34-----41-44

MISSION CONTROL CENTER-HOUSTON-----45-46

MANNED SPACE FLIGHT NETWORK-----47-52

PHOTOGRAPHIC EQUIPMENT-----53-54

APOLLO 7 CREW-----55-69

APOLLO 7 TEST PROGRAM-----70-76

APOLLO CONTRACTORS-----77-81

P  
R  
E  
S  
S  
  
K  
I  
T

NEWS



NATIONAL AERONAUTICS AND SPACE ADMINISTRATION  
WASHINGTON, D.C. 20546

TELS. WO 2-4155  
WO 3-6925

FOR RELEASE: SUNDAY  
October 6, 1968

RELEASE NO: 68-168

FIRST MANNED APOLLO

Apollo 7, the first manned flight in the lunar landing program, will be launched into an Earth orbit Oct. 11 at Cape Kennedy, Fla.

Apollo 7 is an engineering test flight with crewmen Walter M. Schirra, Jr., commander; Donn F. Eisele, command module pilot; and Walter Cunningham, lunar module pilot. (The LM will not be flown on Apollo 7.) Launch will be made on a Saturn IB rocket from Launch Complex 34 at the National Aeronautics and Space Administration's Kennedy Space Center.

-more-

9/27/68

A T.V. camera will be carried on Apollo 7 and live TV pictures will be transmitted to two U.S. ground stations at various times during the mission.

An open-ended mission up to 11 days is planned, but success can be achieved with less than a full-duration flight. Mission sequences are planned to gather the most important data early in the flight. In addition, spacecraft instrumentation is designed to identify systems problems so that they can be analyzed and, if necessary, fixed before subsequent flights.

Combined operation of the Saturn IB launch vehicle, the Apollo command and service modules, and the Manned Space Flight Network during a manned orbital mission will be examined. Unmanned operation in space has been demonstrated.

The Apollo program's forerunners, Mercury and Gemini, provided invaluable operational experience, especially development of rendezvous techniques and knowledge of human and spacecraft performance in space up to two weeks.

Apollo is much more complex than its predecessor Gemini, and is capable of operating at lunar distance.

Apollo 7 is the first of several manned flights aimed at qualifying the spacecraft for the half-million-mile round trip to the Moon. Earlier flights have yielded all the spacecraft information possible without a crew aboard.

The Apollo 7 spacecraft is the product of extensive redesign in the past year and a half. For example, the original two-piece side hatch has been replaced by a quick-opening, one-piece hatch. Extensive materials substitution has reduced flammability within the command module, and systems redundancy has been expanded to reduce single failure points.

This Saturn IB launch vehicle is different from the four unmanned rockets that have preceded it:

- \* The amount of telemetry and instrumentation equipment has been reduced. This lowers vehicle weight and increases its payload capability;

- \* New propellant lines to the augmented spark igniter (ASI) on the J-2 engine of the second stage have been installed to prevent early shutdown as occurred on Apollo 6;

- \* One important event scheduled for the flight is the launch vehicle propellant dump that begins about 1 hour 34 minutes after launch. Dumping all remaining propellants will make the stage safe for rendezvous with the Apollo command service module later in the mission.

\* About 2.5 hours after launch, the astronauts will begin a 25-minute period of manual control of the vehicle from the spacecraft. Then the spacecraft will be separated from the second stage.

The flight of Apollo 7 is the culmination of exacting structural and systems testing on the ground and in space. A spacecraft is flown unmanned in the first few development missions, but the real test of its capability comes when it is checked out in space with men at the controls--the condition for which it was designed and built.

Apollo 7 will be inserted into a 123-by-153 nautical-mile (142 by 176 statute miles, 228 by 284 kilometers) orbit by the launch vehicle's second stage (S-IVB). Spacecraft systems checkout will be the principal activity in the first two revolutions.

Near the end of the second revolution, the crew will separate the spacecraft from the second stage and perform a simulated transposition and docking maneuver, using the spacecraft lunar module adapter attached to the second stage as a target.

Extensive operational checkouts of the environmental control, guidance and navigation, and service propulsion systems will occupy the crew for the next several revolutions. Included will be one of the mission's secondary objectives, rendezvous with the S-IVB approximately 30 hours after lift-off.

Crew activities, systems performance, and ground support facilities will be evaluated in the remainder of the mission. Five additional burns of the service propulsion system are scheduled in that period to further evaluate the service propulsion system and spacecraft guidance modes.

Ten days 21 hours after liftoff, the crew will fire the service propulsion system to deorbit the spacecraft, using the command module guidance and navigation system for control. They will control the spacecraft manually during entry after separation from the service module, using the guidance system as a reference.

Landing is planned in the Atlantic Ocean about 200 nautical miles (230 statute miles, 370 kilometers) southwest of Bermuda at the end of the 164th revolution. The aircraft carrier U.S.S. Essex will be the prime recovery ship.

MISSION OBJECTIVES

Most of the critical tests of spacecraft systems necessary for "wringing out" a new generation of spacecraft take place early in the Apollo 7 flight. The mission has been designed to gather much of the vital data early, in case of premature termination.

Onboard and telemetered data on spacecraft systems performance will pinpoint problems to permit fixes before the next manned Apollo flies.

In addition to checking performance of the crew, prime and backup spacecraft systems and mission support facilities in Earth orbit, the objectives of Apollo 7 are:

- \* Collect data on forward command module heat-shield in entry conditions
- \* Measure change of environmental control system radiator coating in space environment
- \* Perform transposition and simulated docking maneuver with S-IVB stage
- \* Test guidance system's inertial measurement unit in flight
- \* Conduct navigational exercises using landmarks and stars
- \* Optically track a target vehicle (S-IVB stage)
- \* Measure performance of spacecraft propulsion systems
- \* Measure accuracy of propellant gauging system
- \* Gather data on spacecraft systems thermal balance
- \* Evaluate general crew activity in operating command module
- \* Evaluate command module crew displays and controls
- \* Gather data on post-maneuver propellant sloshing
- \* Evaluate quality of air-to-ground voice communications
- \* Control S-IVB attitude manually prior to separation

- \* Evaluate opened spacecraft-lunar module adapter panels
- \* Conduct visual out-the-window horizon attitude reference for de-orbit maneuver
- \* Evaluate procedures for stabilizing spacecraft systems thermal balance during the Earth-return portion of a lunar mission
- \* Rendezvous with S-IVB stage.

-more-



## MISSION DESCRIPTION

(Times given are ground elapse time and are for a nominal mission. Late changes may be made before launch or while the mission is in progress.)

### Launch Phase

Apollo 7 will lift off Eastern Test Range Launch Complex 34 at 11 a.m. EDT, and roll to an azimuth of 72 degrees. The launch window will remain open until about 3 p.m. EDT. Lighting conditions both for launch and recovery are considered in establishing the window.

At insertion, the spacecraft and S-IVB stage will be in a 123-by-153-nautical miles (142 x 176 statute miles, 228 x 284 kilometers) orbit at an inclination of 31.59 degrees to the Equator.

### Orbital Phase

The vehicle will maintain an orbital pitch rate to keep the spacecraft longitudinal axis parallel with the local horizontal until just prior to separation from the S-IVB late in the second revolution.

Remaining S-IVB propellants and cold gases will be dumped through the J-2 engine near the end of the first revolution, and the added velocity from propellant dumping will be about 30 feet-per-second, raising apogee to 171 nm (197 statute miles, 316 kilometers).

If the propellant dump cannot be accomplished, the Apollo 7 spacecraft will separate from the launch vehicle immediately and maneuver to a safe distance. There will be a small amount of residual propellants remaining in the tanks and it is highly improbable that a tank overpressure will exist. However, this remote situation must be considered in the mission planning to ensure the maximum safety for the crew.

At 2 hr. 55 min. GET, the spacecraft will separate from the S-IVB stage with a one-foot-per-second velocity from firing of the service module reaction control thrusters.

-more-

At a distance of 50 feet the differential velocity between the spacecraft and the S-IVB will be reduced to 0.5 feet-per-second while the crew pitches the spacecraft 180 degrees. The remaining .5 feet-per-second velocity will then be damped out and the spacecraft will station keep with the S-IVB while the crew photographs the opened spacecraft/IM adapter panels.

A phasing maneuver of 7.6 feet-per-second retrograde to set up rendezvous with the S-IVB stage at 29 hours (GET) will be made over the Antigua station at 3 hr. 20 min. GET. The maneuver will compensate for the greater drag of the S-IVB, and at the time of the first service propulsion system burn at 26 hr. 25 min. GET, the spacecraft will be an estimated 72 nm (83 sm, 133 km) ahead of the S-IVB.

The first corrective combination service propulsion system burn at 26 hr. 24 min. GET will be a 209 feet-per-second burn with a 72-degree pitch-down attitude. This is the first of two maneuvers to set up a phase angle of 1.32 degrees and a distance of 8.0 nm (9.2 sm, 14.8 km) below the S-IVB in a co-elliptic orbit.

A corrective maneuver to cancel out cumulative errors may be performed over Ascension Island, depending on tracking data gathered since the first SPS burn. If the corrective maneuver is less than 15 feet-per-second, the service module reaction control system thrusters will be used.

The second service propulsion system burn, co-elliptic maneuver, nominally will be made at 28 hr. 00 min. GET when the spacecraft is 82 nm (94 sm, 152 km) behind and 8.0 nm below the S-IVB stage. The burn will be 186 feet-per-second retrograde with a 59-degree pitch-up attitude. The Apollo 7 crew will then begin optical tracking of the S-IVB stage to compute terminal phase burns. Maneuvers performed up to this time will be based on ground computed data.

When the line-of-sight angle to the S-IVB reaches 27.45 degrees, a 17 feet-per-second terminal phase initiation burn will be made. The maneuver nominally will be made over Ascension Island at 29 hr. 22 min. GET at a range of about 15 nm (17.3 sm, 27.8 km). The burn will be made with the service module reaction control system thrusters at a pitch-up attitude of 32 degrees.

Two small mid-course corrections three feet per second and 0.3 feet-per-second will be made in a radially upward direction at 14 min. and 21 min. after terminal phase initiation. These small burns will be calculated in real time to compensate for cumulative errors in onboard guidance targeting for terminal phase initiation.

The braking approach should begin about 29 hr. 36 min. when the spacecraft is about one mile (1.9 km) from the S-IVB, using the service module RCS thrusters. Velocity match (about 18 feet-per-second) and station-keeping at 100 to 200 feet range will continue until revolution 19 state-side pass, when at 30 hr. 20 min. GET, a small service module RCS posigrade burn will break off the rendezvous.

The service propulsion system will not be fired again until revolution 58 over Carnarvon, Australia at three days 19 hr. 43 min. GET. The 116 feet-per-second third SPS burn will be made with a spacecraft attitude of 17.7 degrees pitch up and 122 degrees yaw right, and will lower perigee to 96 nm, (110 sm, 178 km) raise apogee to 155 nm (178 sm, 287 km), provide orbital lifetime to complete the mission, and provide the capability of de-orbit with the RCS thrusters.

In the 77th revolution at a ground elapsed time of five days 00 hr. 52 min., the first of two minimum-impulse SPS burns will be performed. The fourth SPS burn will be in-plane posigrade with a velocity of 15 feet-per-second.

The fifth SPS burn, primarily a test of SPS performance and the propellant utilization and gauging system, will take place at six days 21 hr. 08 min. in the 105th revolution. The 1469-feet-per-second burn will begin under guidance and navigation control system direction, and after 30 seconds will switch over to manual thrust vector control. Spacecraft attitudes during the burn will be set up to target for a 97 by 242 nm orbit (112 x 277 sm, 180 x 406 km).

The second minimum-impulse burn SPS burn no. 6 will nominally take place during the 132nd revolution at eight days 19 hr. 42 min. GET, under guidance and navigation control system, and will impart a velocity of 17 feet-per-second in-plane retrograde.

SPS burn no. 7 at nine days 21 hr. 25 min. in the 150th revolution, will "tune up" the orbit to adjust the location of perigee and to assure landing in the primary recovery zone in the Atlantic at 67 degrees W. longitude. The burn will be controlled by the stabilization and control system and will be calculated to maintain a 91 by 225 nm (105 x 255 sm, 169 x 407 km) orbit through the end of the mission.

The eighth and final SPS burn will be a 279 feet-per-second retrograde de-orbit maneuver at 10 days 21 hr. 08 min. GET in revolution 163. The spacecraft will be pitched down 49.3 degrees during the de-orbit burn to permit the flight crew to verify de-orbit attitude visually and to take over manual control if the guidance and navigation system malfunctions.

### Entry Phase

Approximately 90 seconds after SPS shutdown, the command module will be separated from the service module and placed into entry attitude. Entry will take place about 14 minutes after SPS de-orbit burn at 31.03 degrees N. latitude by 98.83 degrees W. longitude at 400,000 feet.

Spacecraft splashdown should take place about 200 nm (230 sm, 370 km) south-southwest of Bermuda at 10 days 21 hr. 40 min. GET at 29.80 degrees N. latitude by 67.00 degrees W. longitude.

### Recovery Operations

The primary recovery zone for Apollo 7 is in the West Atlantic, centered at 28 degrees N. latitude by 63 degrees W. longitude, where the primary recovery vessel, the aircraft carrier USS Essex will be on station. Expected splashdown for a full 10-day 164-revolution mission will be at 29.8 degrees N. latitude by 67.0 degrees W. longitude, about 200 nm (230 sm, 370 km) south-southwest of Bermuda and 600 nm (690 sm, 1,112 km) east of Cape Kennedy.

Other planned recovery zones and their center coordinates are east Atlantic (23 degrees N. by 27 degrees W), west Pacific (28 degrees N. by 137.5 degrees E), and mid-Pacific (28 degrees N. by 162 degrees W.).

In addition to the Essex, three other vessels will be stationed in the launch abort area. After launch the LSD Rushmore will take up station in the southern part of the west Atlantic recovery zone, while the minesweeper countermeasure ship Ozark will move into the east Atlantic zone. The tracking ship USNS Vanguard will not be committed to recovering Apollo 7 unless a landing should occur in its vicinity following a launch abort.

The USS Essex will be on station in the northern sector of the west Atlantic zone at splashdown.

In addition to surface vessels deployed in the four recovery zones 18 HC-130 aircraft will be on standby at nine staging bases around the Earth: Perth, Australia; Tachikawa, Japan; Pago Pago, Samoa; Hawaii; Lima, Peru; Bermuda; Lajes, Azores; Ascension Island and Mauritius.

Apollo 7 recovery operations will be directed from the Recovery Operations Control Room in Mission Control Center, Houston, and will be supported by the Atlantic Recovery Control Center, Norfolk, Va.; Pacific Recovery Control Center, Kunia, Hawaii; and control centers at Ramstein, Germany, and Albrook AFB, Canal Zone.

The Apollo 7 crew will be flown from the primary recovery vessel to Kennedy Space Center after recovery. The spacecraft will receive a preliminary examination, safing and power-down aboard the Essex prior to offloading at Mayport, Fla., where the spacecraft will undergo a more complete deactivation. It is anticipated that the spacecraft will be flown from Mayport to Long Beach, Calif., within 24 hours, thence trucked to the North American Rockwell Plant in Downey, Calif., for postflight analysis.

-more-

# APOLLO 7

## SECOND PERIOD OF ACTIVITIES

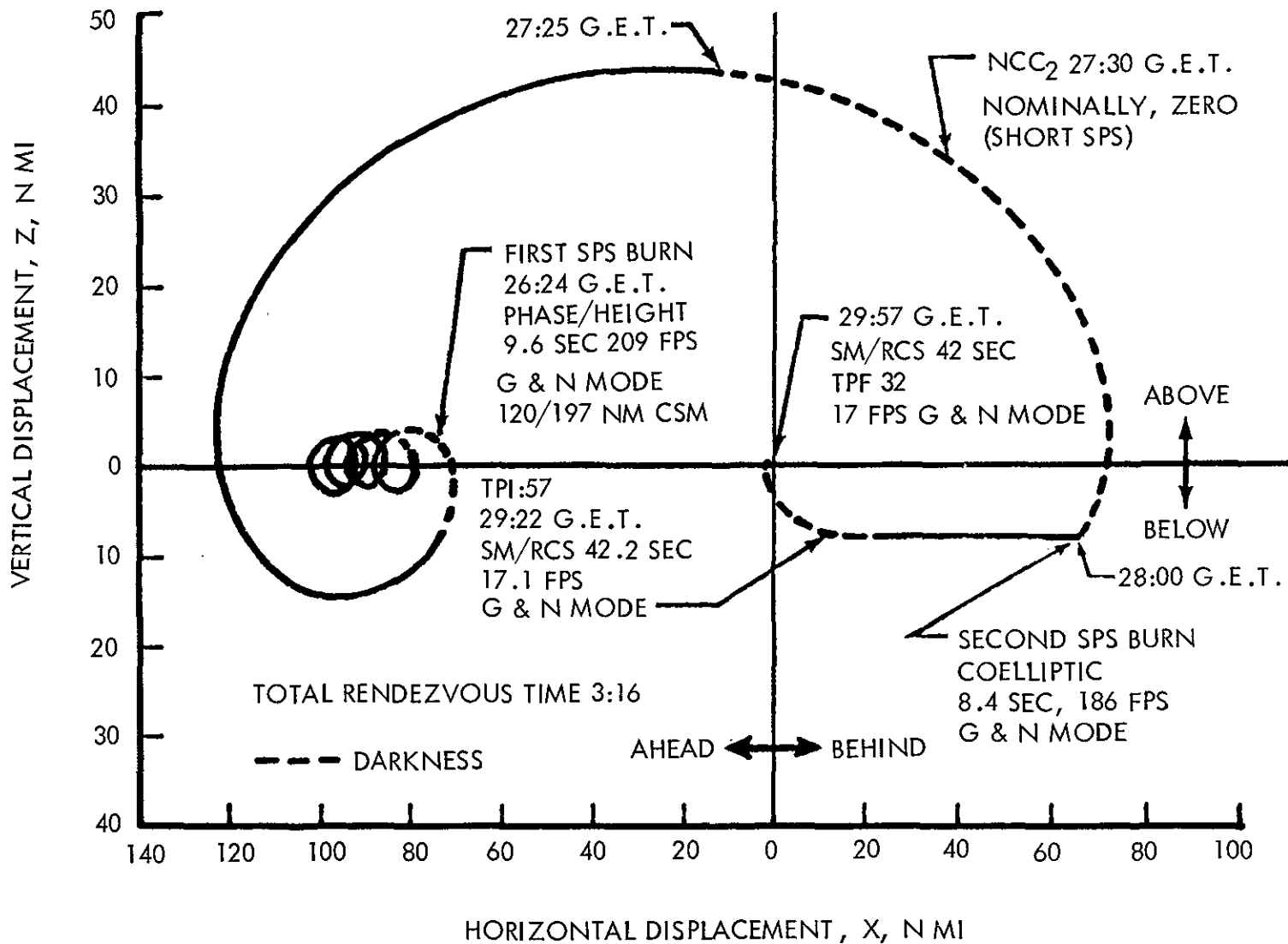

APOLLO 7

THIRD PERIOD OF ACTIVITIES

THIRD SPS BURN

G. E. T. 3:19:43

$t_b = 5.1$  SEC

116 FPS

SCS MODE

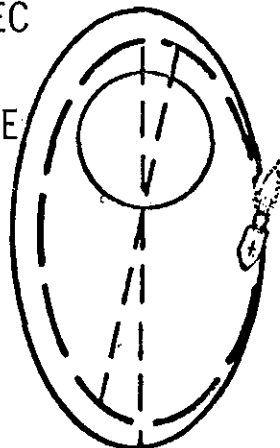

96/155 N MI

FOURTH SPS BURN

G. E. T. 5:00:52

$t_b = 0.5$  SEC

15 FPS

G&N MODE

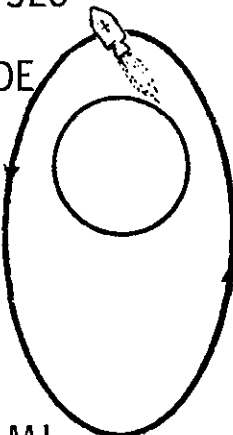

94/160 N MI

FIFTH SPS BURN

G. E. T. 6:21:08

$t_b = 61.5$  SEC

1469 FPS

G & N/  
MTVC  
MODE

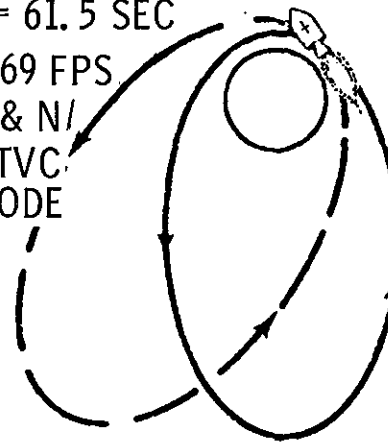

97/242 N MI

SIXTH SPS BURN

G. E. T. 8:19:42

$t_b = 0.5$  SEC

16.9 FPS

G & N MODE

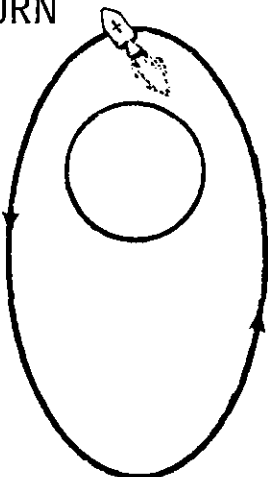

90/237 N MI

SEVENTH SPS BURN

G. E. T. 9:21:25

$t_b = 7.7$  SEC

203 FPS

SCS MODE

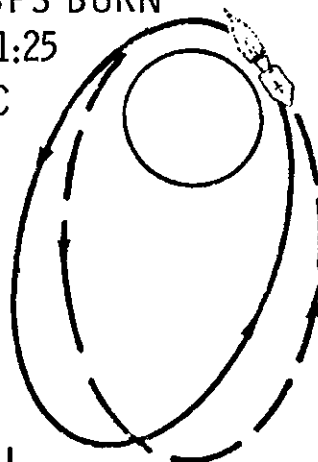

91/225 N MI

-more-

-12b-

# DEORBIT MANEUVER FOR APOLLO 7

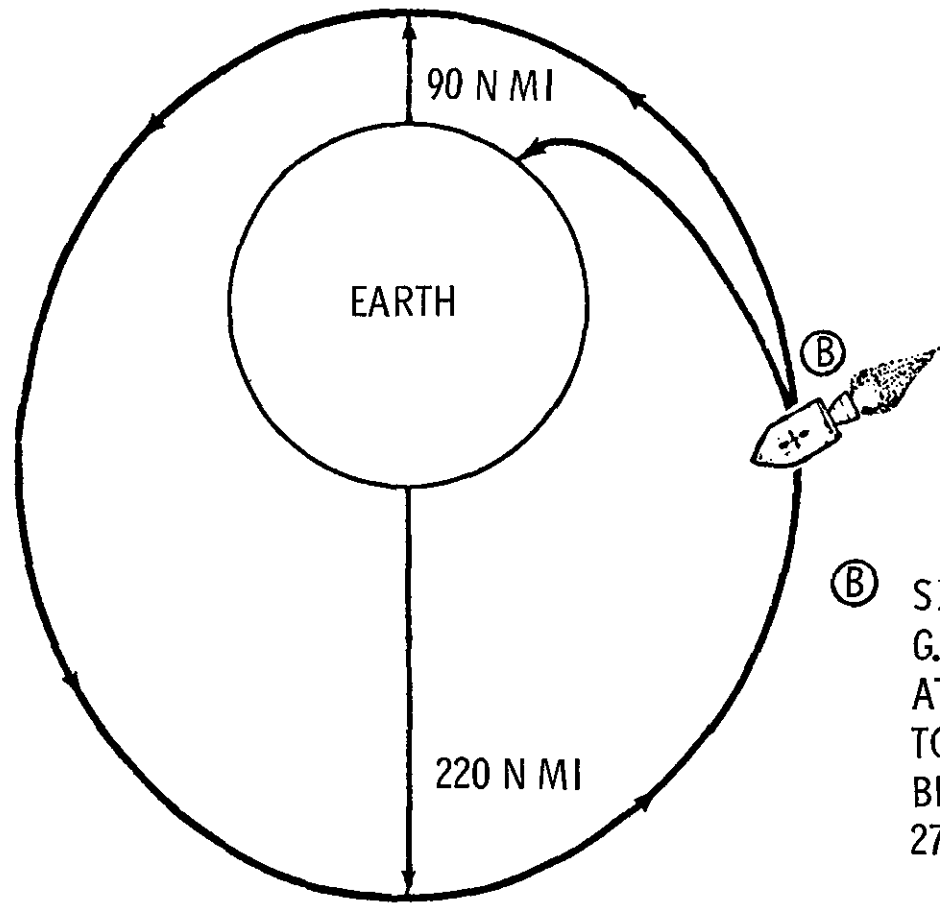

Ⓑ SPS DEORBITAL BURN (G & N MODE)  
G. E. T. = 10:21:08t = 10.2 SECONDS,  
ATLANTIC RECOVERY  
TOUCHDOWN 9 AM  
BERMUDA LOCAL G. E. T. 10:20:12  
279 FPS

-MORE-

-12c-



APOLLO 7  
FIRST PERIOD OF ACTIVITIES

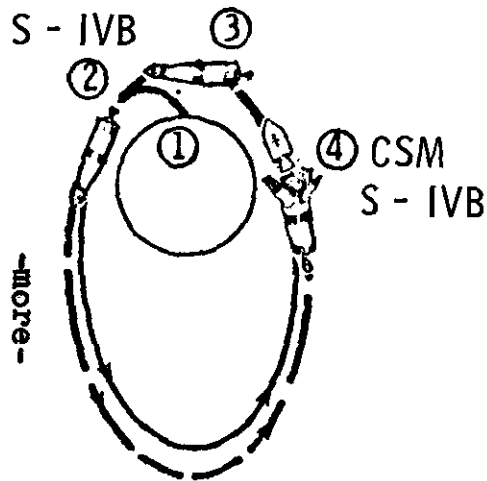

① SM / RCS PHASING MANUEVER; APPLIED TO COMPENSATE FOR TN THE HIGH DIFFERENTIAL DRAG 19.2 SEC 7.6 FPS

125 / 108 N MI CSM  
126 / 171 N MI S - IVB

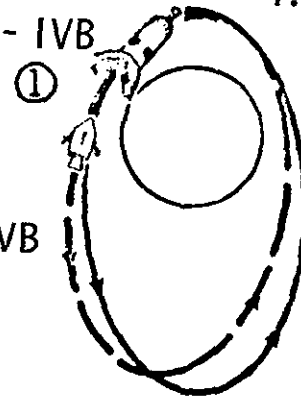

- ① LAUNCH
- ② INSERTION INTO 123/153 N MI ELLIPSE
- ③ S - IVB PROPELLANT DUMP; AT G. E. T. 1:34:30 FPS
- ④ S - IVB/CSM SEPARATION; SM/RCS 2.6 SEC

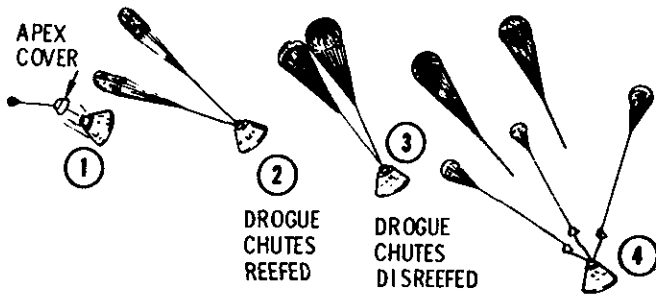

1. APEX COVER JETTISONED AT 24,000 FT +.4 SEC (TLM)
2. DROGUE CHUTES DEPLOYED REEFED AT 24,000 FT +2 SEC (TLM)
3. DROGUE CHUTE SINGLE STAGE DISREEF 10 SEC (TLM)
4. MAIN CHUTE DEPLOYED REEFED VIA PILOT CHUTES AND DROGUE CHUTES RELEASED AT 10,000 FT (TLM)
5. MAIN CHUTE INITIAL INFLATION
6. MAIN CHUTE FIRST STAGE DISREEF 6 SEC
7. VHF RECOVERY ANTENNAS AND FLASHING BEACON DEPLOYED 8 SEC
8. MAIN CHUTE SECOND STAGE DISREEF 10 SEC
9. MAIN CHUTES RELEASED & LM PRESS. PYRO VALVE CLOSED AFTER SPLASH DOWN (TLM)

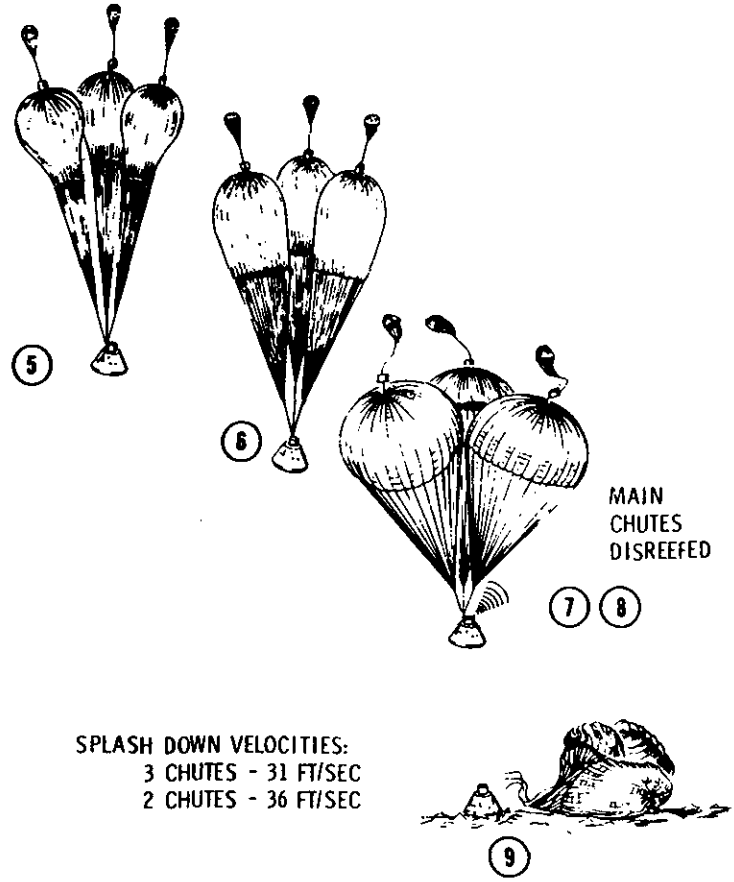

SPLASH DOWN VELOCITIES:  
 3 CHUTES - 31 FT/SEC  
 2 CHUTES - 36 FT/SEC

-MORE-

-12e-

Earth Landing System, Normal Sequence

APOLLO 7 MIS ON EVENTS

<u>Event</u>	<u>Ground Elapsed Time</u> day:hr:min	<u>Velocity</u> ft/sec	<u>Purpose</u>
Orbital insertion	0:00:10	---	Insertion into 123x153 nm orbit (140x176 sm, 228x284 km)
CSM/S-IVB separation	0:02:55	1	
SM RCS phasing burn	0:03:20	-7.5	Set up rendezvous phasing
First SPS burn	1:02:24	209	Corrective combination maneuver
Second SPS burn	1:04:00	185.6	Concentric maneuver
Terminal Phase Initiate	1:05:23	17.1	Final approach for S-IVB rendezvous
Post-rendezvous separation	1:06:20	2	Assure no CSM/S-IVB recontact
Third SPS burn	3:19:43	116	Tune up orbit; set up for fuel gauge test
Fourth SPS burn	5:00:52	15	First minimum-impulse test
Fifth SPS burn	6:21:08	1469	Tune up orbit for life-time, deorbit position; test of fuel gauging system
Sixth SPS burn	8:19:42	-17	Second minimum-impulse test
Seventh SPS burn	9:21:25	203	Adjust orbit for proper location of deorbit burn, landing
Eighth SPS burn	10:21:08	-278.9	De-orbit

## Apollo 7 Rendezvous

While Earth orbit rendezvous of a spacecraft with a target vehicle was accomplished many times in the Gemini program, the Apollo 7 rendezvous with the S-IVB stage has further implications for future lunar landing missions. The main purpose of Apollo 7 rendezvous is to demonstrate the capability to rendezvous with and rescue a lunar module after an aborted lunar landing, or after the lunar module has staged from the lunar surface into lunar orbit.

The rendezvous trajectory techniques are essentially the same as those developed in Gemini phasing, corrective combination and co-elliptic maneuvers followed by the terminal phase maneuver when the spacecraft is 15 nm (17.3 sm, 27.8 km) behind and at a constant differential height of about 8 nm (9.2 sm, 14.8 km) below the target.

Also significant is the fact that during a LM rescue the CSM must be flown by one crewman a situation that requires ground control to bring the CSM up to the terminal phase while the crewman performs the rest of the rendezvous using onboard computer and line-of-sight control to the LM.

## Apollo 7 Guidance Techniques

Many of the Apollo 7 principal test mission objectives are concerned with a thorough checkout of navigation and guidance equipment for this third generation of manned spacecraft.

Primary guidance is obtained by a combination of computer programs and inertial platform and optics inputs. Backup control, in case of primary guidance failure, is furnished by the stabilization and control system which uses body-mounted attitude gyros.

As a precursor to navigation in a trans-Earth trajectory in later lunar landing flights, the Apollo 7 crew will conduct mid-course navigation sextant sightings using combinations of stars and Earth horizon. Later missions will use the star-lunar landmark-horizon technique.

The S-IVB stage will serve as a sextant tracking target during the rendezvous phase. Optical tracking and rendezvous navigation techniques will be emphasized to gain experience and confidence in these systems. In the Gemini flights, the primary target tracking mode was with rendezvous radar.

Inputs from the Inertial Measurement Unit (IMU) and the optical navigation devices are processed by the command module computer.

FLIGHT PLAN

The Apollo 7 flight plan calls for at least one crew member to be awake at all times. The normal cycle will be 16 hours of work followed by eight hours of rest. The command pilot and lunar module pilot sleep periods are scheduled simultaneously.

Early in the flight, the crew may doff pressure suits and don the inflight coveralls.

Two full night passes are needed to orient the inertial measurement unit (IMU) and to ready other systems before any crew activity involving the guidance and navigation system. When the IMU orientation is known but is determined to be inaccurate, the flight plan calls for one full night pass for realignment of the IMU platform.

Crew work-rest cycles have been planned so that all three crewmen are awake for at least a half-hour before IMU orientations that precede a maneuver using the service propulsion system.

The flight plan schedules an hour for each meal period with all three crewmen eating together whenever possible. Other mission activities, such as experiments, status reports and maneuvers will be kept to a minimum during meal periods.

Spacecraft systems checkouts will be scheduled periodically by the crew to coincide with planned check list procedures. Lithium hydroxide canisters for removal of carbon dioxide from the cabin atmosphere will be changed each 12 hours, with the first canister removed 10 hours after lift-off.

Air-to-ground voice communications will be on the VHF frequency, although the unified S-band equipment will be powered throughout the mission for testing and as a VHF backup.

During a state-side pass once each day, the crew will report to Mission Control Center such information as times of accomplishing flight plan tasks, film type and quantity used and lithium hydroxide canister changes.

The spacecraft communicator in Mission Control Center in turn will provide flight plan updates on a daily basis.

Following is a brief summary of tasks to be accomplished in Apollo 7 on a day-to-day schedule. The tasks are subject to changes to suit opportunity or other factors.

Launch day (0-24 hours):

- \* Spacecraft-S-IVB orbital operations prior to separation
- \* S-IVB safing and fuel jettison
- \* Demonstrate S-IVB takeover
- \* Transposition and simulate docking with spacecraft-LM adapter
- \* Photograph deployed spacecraft-LM adapter panels
- \* Phasing maneuver using service module reaction control system
- \* Checkout spacecraft systems
- \* Cryogenic stratification test No. 1
- \* Calibrate sextant and crew optical alignment sight (COAS)

Second day (24-48 hours):

- \* Service propulsion systems burns Nos. 1 and 2
- \* Rendezvous with S-IVB
- \* Track S-IVB post-rendezvous at 80 and 160 nm (92 x 184 sm 148 x 296 km) ranges

Third day (48-72 hours):

- \* Track S-IVB at 320 nm range (368 sm, 593 km)
- \* Daylight star visibility test No. 1
- \* S005, S006 photographic experiments

Fourth day (72-96 hours):

- \* Lunar module rendezvous radar test No. 1 over White Sands, N. M., Test Facility
- \* Landmark tracking

- \* Daylight star visibility test No. 2
- \* S005, S006 photographic experiments
- \* Service propulsion system burn No. 3
- \* Slosh damping test No. 1
- \* Environmental control system radiator test

Fifth day (96-120 hours):

- \* Mid-course navigation exercise
- \* Cryogenic stratification test No. 2

Sixth day (120-144 hours):

- \* Service propulsion system burn No. 4
- \* Slosh damping test No. 2
- \* Daylight star visibility test No. 3
- \* Service propulsion system cold soak
- \* Landmark tracking

Seventh day (144-168 hours):

- \* Service propulsion system burn No. 5
- \* Service propulsion system cold soak
- \* Passive thermal control test No. 1
- \* Mid-course navigation exercise
- \* Photograph rendezvous window coating

Eighth day (168-192 hours):

- \* S005, S006 photographic experiments
- \* Test environmental control system secondary coolant loop

Ninth day (192-216 hours):

- \* Lunar module rendezvous radar test No. 2 over White Sands Test Facility
- \* Daylight star visibility test No. 1
- \* Perform backup alignment of stabilization control system
- \* Service propulsion system burn No. 6
- \* Passive thermal control tests Nos. 2 and 3

Tenth day (216-240 hours):

- \* Service propulsion system burn No. 7
- \* Calibrate sextant
- \* Determine bias of pulse integrating pendulous accelerometer (PIPA) and entry monitor system (EMS)
- \* S005, S006 photographic experiments

Eleventh day (240 hours-de-orbit):

- \* Photograph rendezvous window coating
- \* Cryogenic stratification test No. 3
- \* De-orbit burn



### ALTERNATE MISSIONS

The preceding mission description is for a nominal or prime mission. Plans may be altered at any time to meet changing conditions.

In general, three alternate missions (one-day, two-day and three-day) are ready if necessary. Each of these, in turn, has variations depending on whether the S-IVB stage is available, what spacecraft system problems are encountered and the amount of service propulsion system propellants available. In addition, alternate rendezvous plan, if a one-day delay occurs, has been prepared. Alternate missions greater than three days will be planned in real time.

#### One-Day Mission Plans

Four plans are being considered for one-day alternate missions. The first two, called 1a and 1b, terminate with a landing in the middle Pacific Recovery Zone in the sixth revolution. Alternates 1c and 1d terminate in the West Atlantic near the end of the first day. In the alternate one-day missions the service propulsion system will be used only for the de-orbit burn except if needed to place the command and service module in orbit. Alternates 1b and 1d follow the prime mission's first-day flight plan.

#### Two-Day Mission Plans

Three two-day mission plans, alternates 2a, 2b, 2c, are being considered. Two days do not permit all test objectives to be met. The mission can have a rendezvous and two additional Service Propulsion System (SPS) maneuvers (one for de-orbit) or no rendezvous and four maneuvers (one for de-orbit).

Alternate 2a. - Alternate 2a assumes the S-IVB is in an acceptable orbit and has been made safe. In this case, the rendezvous will occur as in the prime mission, the de-orbit will be under Guidance, Navigation and Control System control, and the other maneuver will be used to evaluate Stabilization and Control System control.

The latter burn would occur over Carnarvon in revolution 28. The de-orbit burn of the former would occur over Hawaii in revolution 31, with landing in the west Atlantic in revolution 32.

If the Stabilization and Control System burn were extended to approximately 70 seconds, the system performance and gauging tests could be accomplished.

Alternate 2b.- Alternate 2b assumes a burn of the Stabilization and Control System for Contingency Orbit Insertion of less than 31 seconds. The first maneuver will be a Guidance and Navigation Control System burn in revolution 16 over Carnarvon to adjust the propellant level for the gauging system test. If the Contingency Orbit Insertion burn did not satisfy the test requirement for the Stabilization System, this first maneuver would be under control of that System. If the Insertion burn were between 28 and 31 seconds, this maneuver could be a minimum-impulse test.

A 57-second burn for test of the Service Propulsion System (SPS) performance, gauging and Guidance and Navigation Control System Manual Thrust Vector Control will occur over Cape Kennedy in revolution 19. A minimum impulse test will be performed over Carnarvon in revolution 29 and the Guidance System de-orbit burn over Hawaii occurs in revolution 32 for a west Atlantic landing in revolution 33.

Because the CSM-active rendezvous objective can be traded for tests of the minimum-impulse, gauging system, and manual takeover, this plan may be preferable to the 2a plan when possible.

Alternate 2c.- The third two-day plan assumes that the S-IVB is not available and that a Contingency Orbit Insertion burn of more than 31 seconds has occurred. Such a burn would suffice for test of the Stabilization Control System.

The first scheduled maneuver would be performed over Cape Kennedy in revolution 17. The burn objective will be a minimum impulse test. The second maneuver would occur two revolutions later over Cape Kennedy. Burn objectives depend on the exact propellant level. The most desirable objective would be a Guidance and Navigation System-Manual Thrust Vector Control maneuver. This requires a minimum maneuver time of 35 seconds.

If this time is unavailable, the maneuver will be a Guidance System-controlled, orbit-shaping maneuver that uses available propellants. The third maneuver will be a second minimum-impulse test over Carnarvon in revolution 29. The de-orbit maneuver would be over Hawaii in revolution 32, landing in the west Atlantic in revolution 33.

### Three-Day Mission Plans

There are three three-day missions which would allow all mission objectives to be scheduled.

Alternate 3a.- Assuming the S-IVB is available, the rendezvous will occur as in the prime mission. In revolution 28 a Stabilization Control System burn over Carnarvon would adjust the level for the test of the Service Propulsion System performance and gauging system. These tests would be performed over Cape Kennedy in revolution 32. A minimum-impulse test would be performed shortly before the Guidance and Navigation Control System in revolution 45 over Hawaii. Landing will be in revolution 46 in the west Atlantic.

Alternate 3b.- With the S-IVB unavailable and a Contingency Orbit Insertion burn of less than 31 seconds, the first maneuver would be controlled by the Guidance and Navigation System in revolution 17 over Cape Kennedy to adjust the propellant level for Service Propulsion System (SPS) performance and gauging system tests. If the Insertion burn did not provide a satisfactory test of the Stabilization Control System, this maneuver will be under control of that System. The second maneuver will be a minimum-impulse test over Cape Kennedy two revolutions later. The SPS performance and gauging system tests will occur over Cape Kennedy in revolution 32. A second minimum-impulse test will be performed shortly prior to the Guidance System de-orbit, in revolution 47 over Hawaii.

Alternate 3c. - The third three-day plan considers that the S-IVB is unavailable and that a Contingency Orbit Insertion burn of more than 31 seconds has occurred. That burn would suffice for test of the Stabilization Control System. The first maneuver would be a minimum-impulse test over Cape Kennedy in revolution 17. The objector of the second maneuver, over Cape Kennedy two revolutions later, will be determined by the propellant level as on alternate 2c. The second minimum-impulse test would be over Cape Kennedy in revolution 32. The Guidance and Navigation System de-orbit burn will occur over Hawaii in revolution 46 with a landing in the west Atlantic in revolution 47.

#### Alternate Rendezvous Plan

The only alternate rendezvous plan being considered is a one-day delay. Alternate rendezvous plans with a delay of one revolution are ruled out because of the loss of good coverage by the tracking network. A rendezvous delay of more than one day is not planned because of the drag uncertainties of the S-IVB. A one-day delay in the rendezvous allows approximately the same maneuver plan, the same station coverage and the same lighting.

The plan involves deleting the phasing maneuver at 26 hours 25 minutes GET and making, instead, a maneuver with the Service Module Reaction Control System to reestablish the near nominal phasing (CSM leading by about 75 nautical miles (86 statute miles, 139 kilometers) one day later. The burn of about 12 feet-per-second of that system has been scheduled over Ascension Island in revolution 18 about 27 hours 30 minutes GET. The phasing and concentricity maneuvers necessary for rendezvous will delay about one day and the terminal phase will follow essentially the same plan as that of the nominal. The remainder of the mission follows the nominal operational trajectory.

-more-

APOLLO 7 ALTERNATE MISSIONS OBJECTIVES

MISSION PRIORITY	1	5	6	7	11	12	13	14	18	38	
DTO#	7.19	3.15	3.14	1.13	2.5	20.13	1.10	20.8	2.6	57.21	
ALTERNATE MISSION	RADIATOR TEST	SPS PERFORMANCE	SPS MINIMUM IMPULSE	GNCS ΔV CONTROL	SCS ΔV CONTROL	CSM-ACTIVE RENDEZVOUS	SEXTANT TRACKING	TRANSPOSITION AND DOCKING	GNCS/MTVC ΔV TAKE OVER	SLA DEPLOYMENT	COMMENTS
1A				◐	●						
1B				◐				●		●	
1C	○			◐	●						
1D	○			◐				●		●	
2A	●			●	●	●	●	●		●	
2B	●	●	◐	●	●		○	○	●		S-IVB RELATED TEST OBJECTIVES SATISFIED IF COI=0
2C	●		●	●	●				○		MANUAL TAKE OVER BURN MUST BE AT LEAST 35 SECONDS LONG
3A	●	●	◐	●	●	●	●	●	●	●	
3B	●	●	●	●	●				●		
3C	●		●	●	●				○		MANUAL TAKE OVER BURN MUST BE AT LEAST 35 SECONDS LONG
ALTERNATE RENDEZVOUS	●	●	●	●	●	●	●	●	●	●	

DETAILED TEST OBJECTIVE ACCOMPLISHMENT FOR THE APOLLO 7 ALTERNATE MISSIONS

- FULFILLED
- ◐ PARTIALLY FULFILLED
- POSSIBLY FULFILLED

EXPERIMENTS

Five experiments will be carried out in the Apollo 7 mission. They are:

\* S005-synoptic terrain photography -- The Apollo 7 crew will photograph land and ocean areas for geologic, geographic and oceanographic study and for evaluation of various film types.

\* S006-synoptic weather photography -- Global as well as local weather systems will be photographed by the crew for use by scientists in improving techniques of interpretation of orbital altitude weather photographs.

Both photography experiments may require service module reaction control system propellants for attitude control. Selections of areas and weather systems to be photographed will be made by the crew as the opportunities arise.

\* M006-bone demineralization -- Pre- and post-flight X-ray studies of selected bones of crew members is aimed toward establishing occurrence and degree of bone demineralization during long space flights.

\* M011-blood studies -- Pre- and post-flight crew blood samples are compared to determine if the space environment fosters any cellular changes in human blood.

\* M023-lower body negative pressure -- Pre- and post-flight medical examinations will measure change in lower body negative pressure as evidence of cardiovascular deconditioning resulting from prolonged weightlessness.

All three medical experiments require no in-flight crew activity nor use of any spacecraft consumables.

ABORT MODES

From Apollo 7 liftoff until orbital insertion, there are four periods (modes) in which the mission may be aborted either by the emergency detection system or by the crew.

They are:

Mode I -- Liftoff to launch escape tower jettison, 2 min. 44 sec. GET: Launch escape system initiated automatically or by crew command when two launch vehicle engines fail or excessive rates build up. Drogue and main parachutes deploy after tower jettison and command module lands up to 400 nm (460 sm, 741 km) downrange.

Mode II -- 2 min. 44 sec. to 9 min. 33 sec., GET: Separation of Command Service Module from S-IVB, 20-second service module Reaction Control System, separation of Command and Service Modules and full-lift entry, and landing from 400 to 3,200 nm (460 to 3,680 sm, 741 to 5,930 km) downrange.

Mode III -- 9 min. 33 sec., GET to insertion (9 min. 53 sec. GET): Separation sequence same as Mode II, but service propulsion system burn retrograde. Command module flown in open-loop entry to recovery area at 3,200 nm (3,680 sm, 5,930 km).

Mode IV -- 9 min. 27 sec., GET to insertion: Service propulsion system used to insert spacecraft into orbit, leaving enough Service Propulsion System fuel for de-orbit burn.

-more-

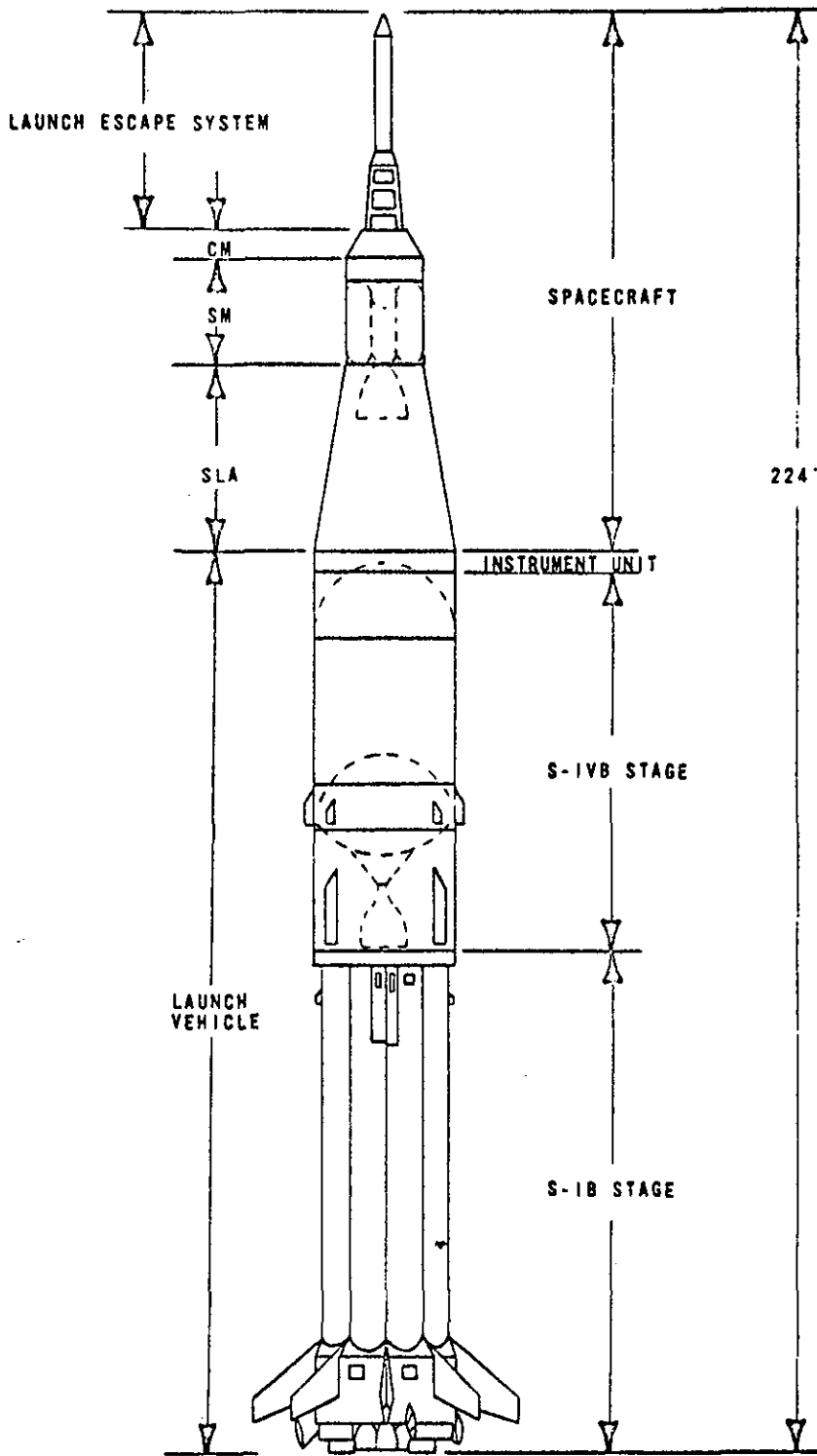

Figure 5 - Apollo 7 Space Vehicle



## SPACECRAFT STRUCTURE SYSTEMS

Apollo spacecraft No. 101 for the Apollo 7 mission is comprised of a launch escape system, command module, service module and a spacecraft-lunar module adapter. The latter serves as a mating structure to the instrument unit atop the S-IVB stage of the Saturn IB. For this mission, it does not contain a lunar module.

Launch Escape System--Propels command module to safety in an aborted launch. It is made up of an open-frame tower structure mounted to the command module by four frangible bolts, and three solid-propellant rocket motors: a 155,000-pound-thrust launch escape system motor, a 33,000 pound-thrust tower jettison motor, and a 3,000-pound-thrust pitch control motor that bends the command module trajectory away from the launch vehicle and pad area. Two canard vanes near the top deploy to turn the command module aerodynamically to an attitude with the heat-shield forward. Attached to the base of the Escape System is a boost protective cover composed of glass, cloth and honeycomb, that protects the command module from rocket exhaust gases from the main and the jettison motor. The system is 33 feet tall, four feet in diameter at the base and weighs 8,900 pounds.

Command Module Structure--The basic structure of the command module is a pressure vessel encased in heat-shields, cone-shaped 12 feet high, base diameter of 12 feet 10 inches, and launch weight 12,659 pounds.

The command module consists of the forward compartment which contains two negative pitch reaction control engines and components of the Earth landing system; the crew compartment, or inner pressure vessel, containing crew accommodations, controls and displays, and spacecraft systems; and the aft compartment housing ten reaction control engines and fuel tankage.

Heat-shields around the three compartments are made of brazed stainless steel honeycomb filled with phenolic epoxy resin as an ablative material. Heat-shield thickness, varying according to heat loads, ranges from 0.7 inches to 2.7 inches on the aft side.

The spacecraft inner structure is of aluminum alloy sheet-aluminum honeycomb bonded sandwich ranging in thickness from 0.25 inches thick at forward access tunnel to 1.5 inches thick at base.

Service Module Structure--The service module is a cylinder 12 feet 10 inches in diameter by 22 feet long.

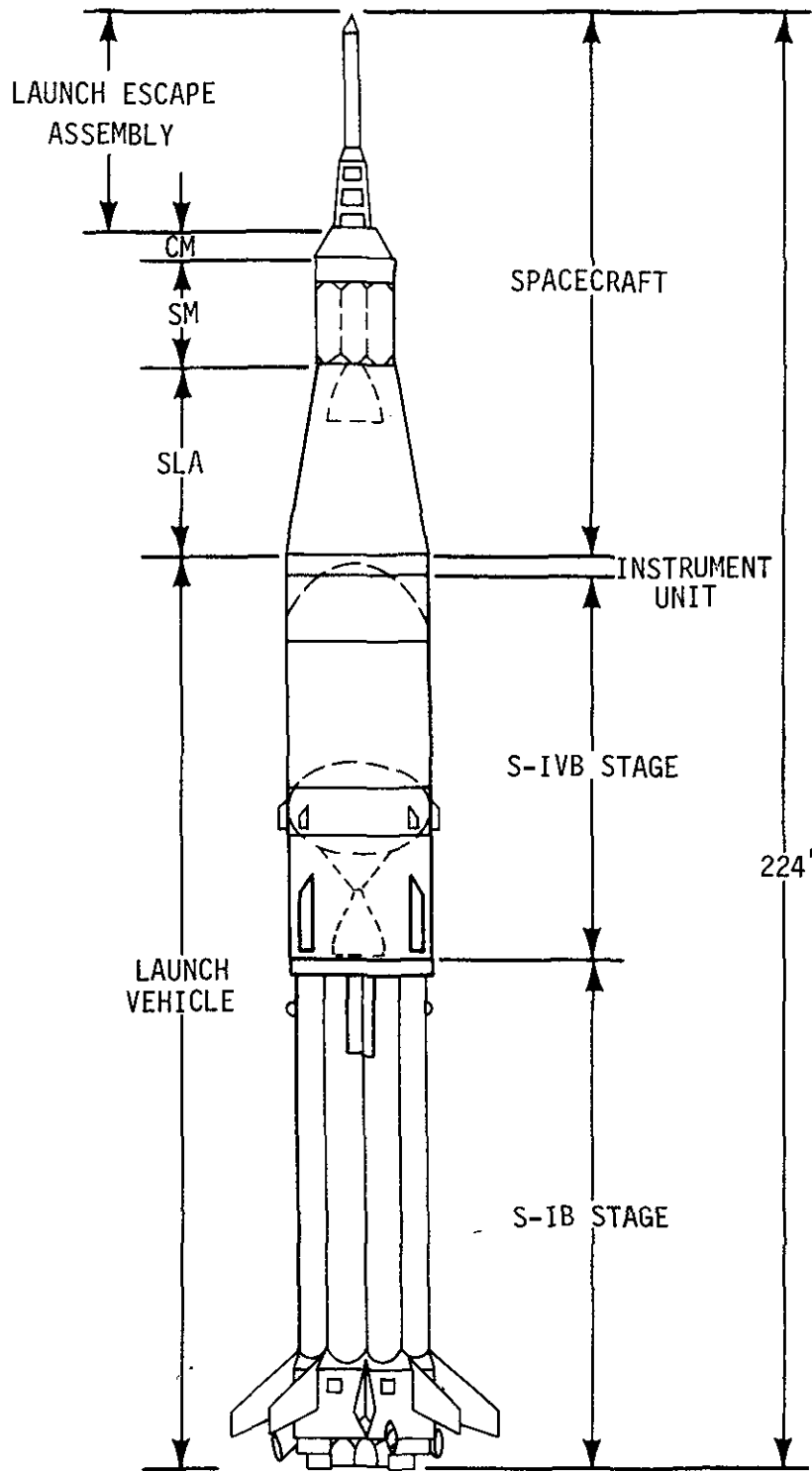

APOLLO 7 SPACE VEHICLE

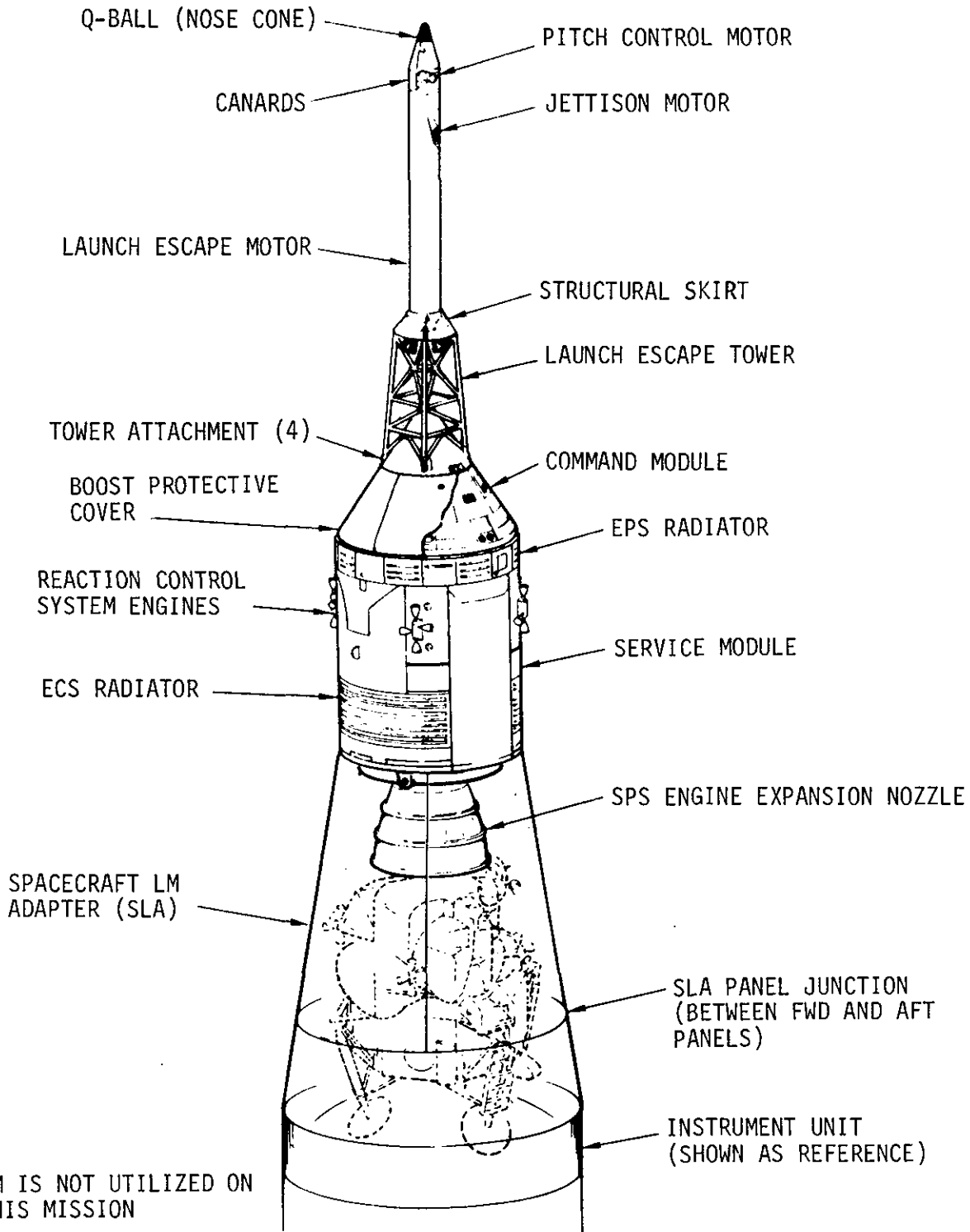

NOTE: LM IS NOT UTILIZED ON THIS MISSION

SPACECRAFT CONFIGURATION

# LAUNCH ESCAPE SYSTEM

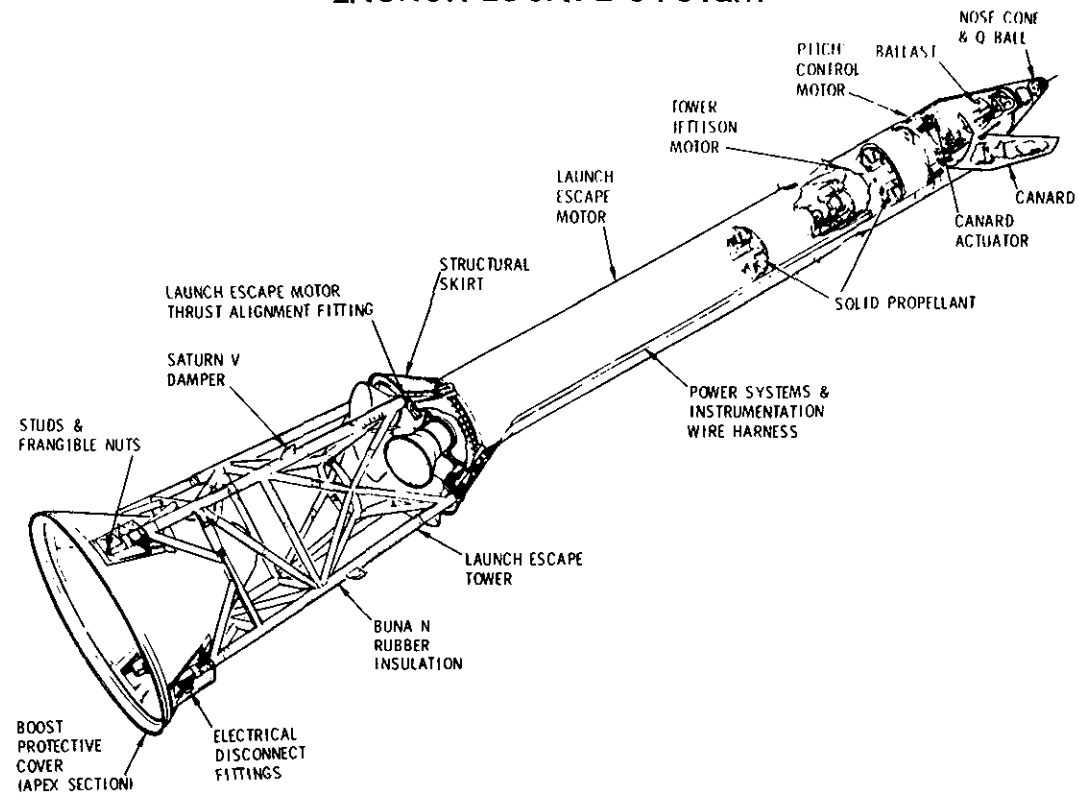

# SLA PANEL

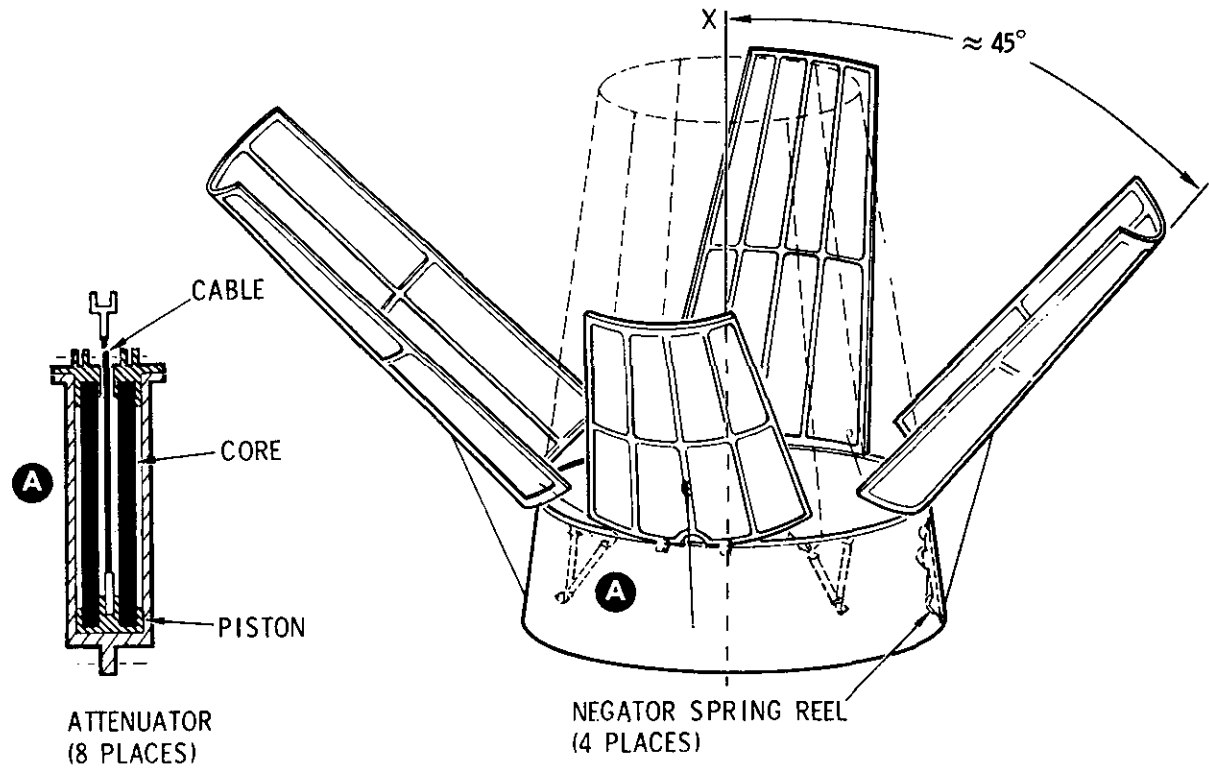

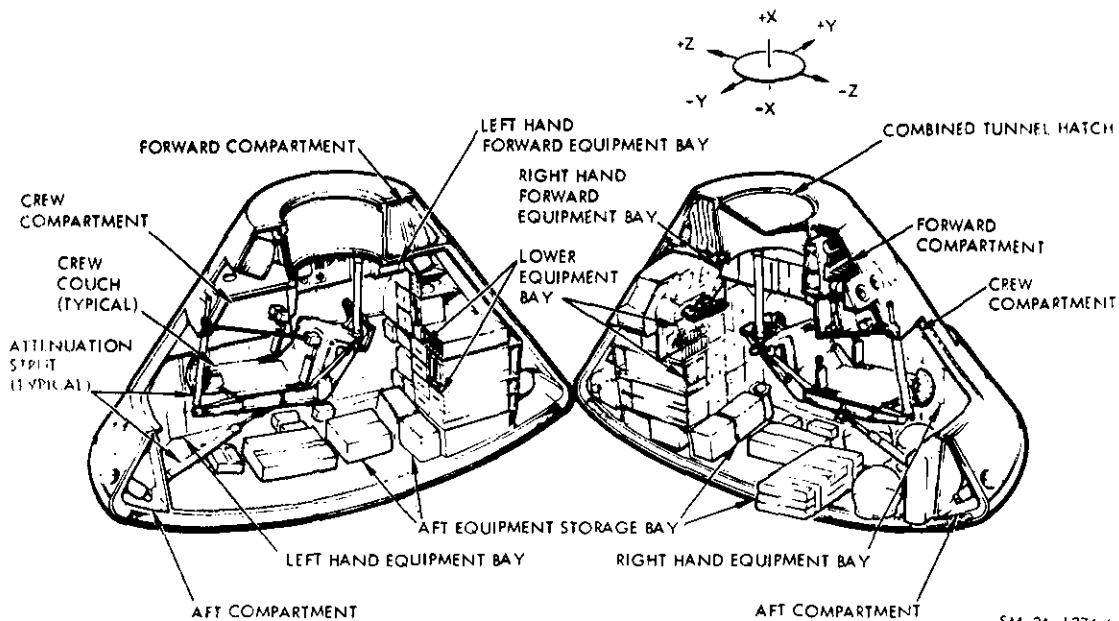
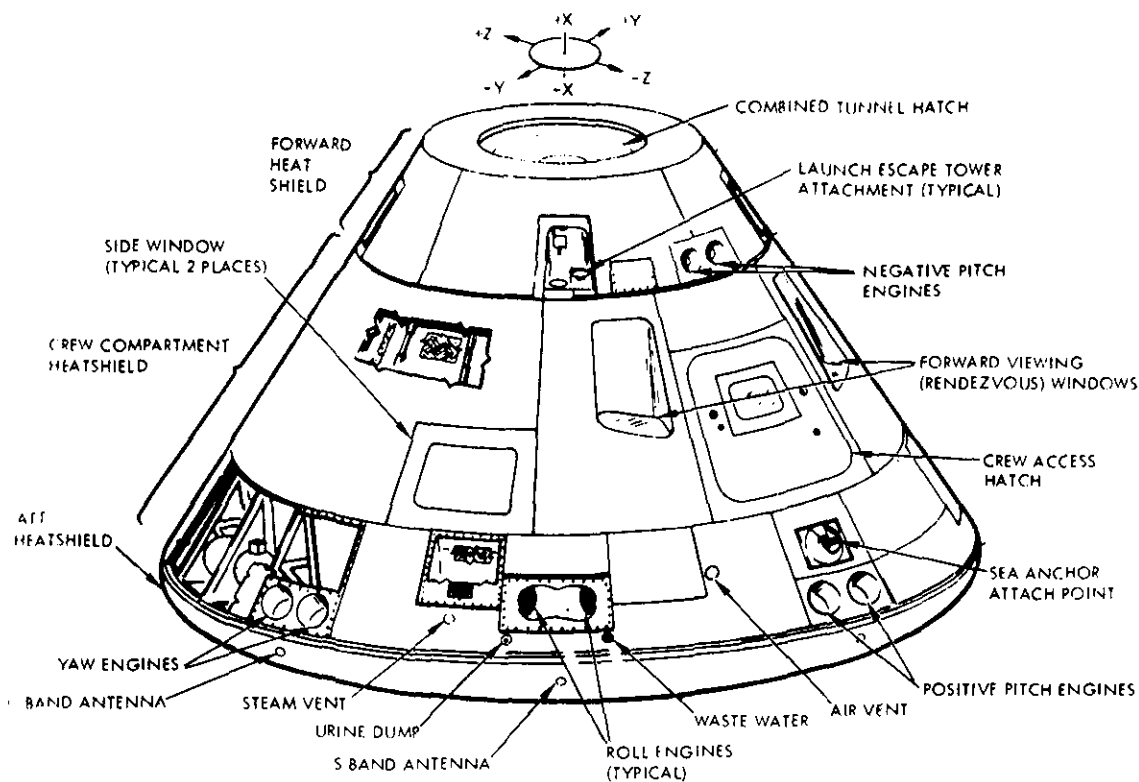

SM-2A-1274 A

### APOLLO COMMAND MODULE

For the Apollo 7 mission, it will weigh 19,730 pounds at launch. Aluminum honeycomb panels one inch thick form the outer skin, and milled aluminum radial beams separate the interior into six sections containing service propulsion system and reaction control fuel-oxidizer tankage, fuel cells and onboard consumables.

Spacecraft-LM Adapter Structure--The spacecraft-LM adapter is a truncated cone 28 feet long tapering from 260 inches diameter at the base to 154 inches at the forward end at the service module mating line. Aluminum honeycomb 1.75 inches thick is the stressed-skin structure for the spacecraft adapter, which will house the Lunar Module on Saturn V flights. On Apollo 7, the adapter serves as a structural inter-stage between the instrument unit atop the S-IVB stage and the service module. It weighs 3,800 pounds.

### Spacecraft Systems

\*Guidance, Navigation and Control System--Measures and controls spacecraft attitude and velocity, calculates trajectory, controls Spacecraft Propulsion System thrust vector and displays abort data. The Guidance System consists of three subsystems: inertial, made up of inertial measuring unit and associated power and data components; computer, consisting of display and keyboard panels and digital computer which processes information to or from other components; and optic, including scanning telescope, sextant for celestial and/or landmark spacecraft navigation.

\*Stabilization and Control System--Controls spacecraft rotation, translation and thrust vector and provides displays for crew-initiated maneuvers; backs up the guidance system. It has three subsystems; attitude reference, attitude control and thrust vector control.

\*Service Propulsion System--Provides thrust for large spacecraft velocity changes and de-orbit burn through a gimbal-mounted 20,500-pound-thrust hypergolic engine using nitrogen tetroxide oxidizer and a 50-50 mixture of unsymmetrical dimethyl hydrazine and hydrazine fuel. Tankage of this system is in the service module. The system responds to automatic firing commands from the guidance and navigation system or to manual commands from the crew. The engine provides a constant thrust rate. The stabilization and control system gimbals the engine to fire through the spacecraft center of gravity.

\*Reaction Control System--This includes two independent systems for the command module and the service module. The service module reaction controls have four identical quads

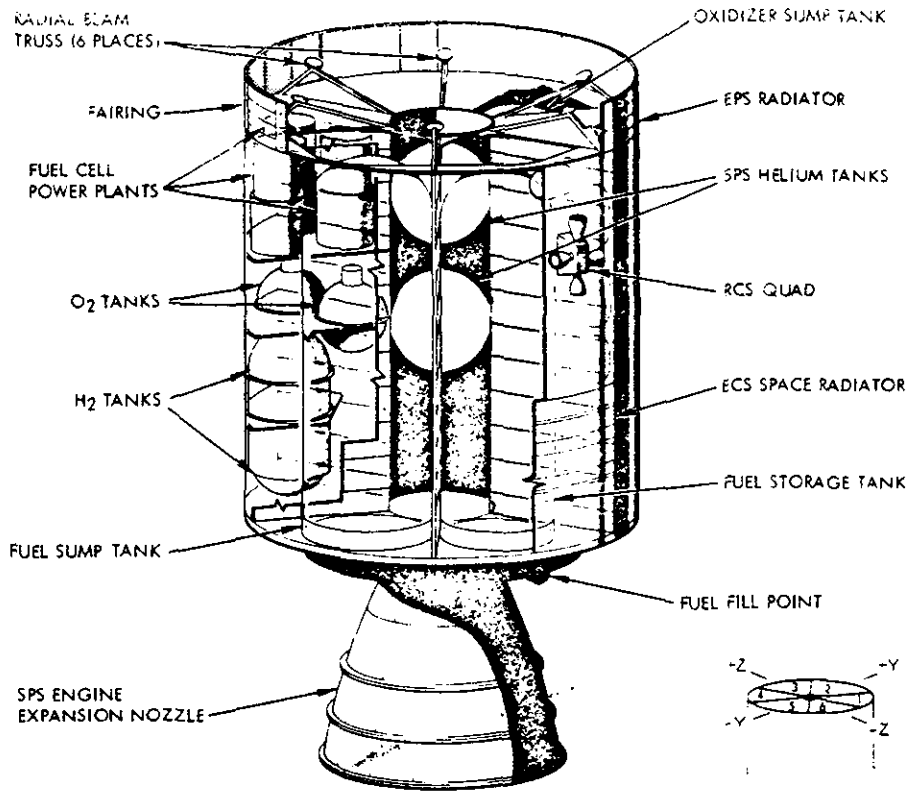

1 AND 4 ARE 50-DEGREE SECTORS  
 2 AND 5 ARE 70-DEGREE SECTORS  
 3 AND 6 ARE 60-DEGREE SECTORS

SERVICE MODULE ITEMS

Sector I  
 Empty NASA equipment

Sector II  
 Environmental system space radiator  
 Service propulsion system  
 Reaction control system package (+Y-axis)  
 Service propulsion system oxidizer sump tank

Sector III  
 Service propulsion system  
 Reaction control system package (+Z-axis)  
 Environmental system space radiator  
 Service propulsion system oxidizer storage tank

Sector IV  
 Fuel cell power plant (three)  
 Helium servicing panel  
 Super-critical oxygen tank (two)  
 Super-critical hydrogen tank (two)  
 Reaction control system control unit  
 Electrical power system power control relay box  
 Service module jettison controller sequencer (two)

Sector V  
 Environmental control system space radiator  
 Service propulsion system fuel sump tank  
 Reaction control system package (-Y axis)

Sector VI  
 Environmental control system space radiator  
 Reaction control system package (-Z axis)  
 Service propulsion system fuel storage tank

Center Section  
 Service propulsion system helium tank (two)  
 Service propulsion system engine

Fairing  
 Electrical power system space radiator's (eight)

SM-2A-1278

APOLLO SERVICE MODULE

of four 100-pound thrust hypergolic engines mounted, near the top of the Service Module, 90 degrees apart to provide redundant spacecraft attitude control through cross-coupling logic inputs from the Stabilization and Guidance Systems. Small velocity change maneuvers can also be made with the Service Module reaction controls. The Command Module Reaction Control System consists of two independent six-engine subsystems of 94 pounds thrust each. One is activated after separation from the Service Module, and is used for spacecraft attitude control during entry. The other is maintained in a sealed condition as a backup. Propellants for both systems are monomethyl hydrazine fuel and nitrogen tetroxide oxidizer with helium pressurization. These propellants are hypergolic, i.e.: they burn spontaneously on contact without need for an igniter.

\*Electrical Power System--Consists of three 31-cell Bacon-type hydrogen-oxygen fuel cell power plants in the Service Module which supply 28-volt DC power, three 28-volt DC zinc-silver oxide main storage batteries in the Command Module lower equipment bay, two pyrotechnic batteries in the Command Module lower equipment bay, and three 115-200-volt 400-cycle three-phase AC inverters powered by the main 28-volt DC bus. The inverters are also located in the lower equipment bay. Supercritical cryogenic hydrogen and oxygen react in the fuel cell stacks to provide electrical power, potable water and heat. The Command Module main batteries can be switched to fire pyrotechnics in an emergency. A battery charger builds the batteries to full strength as required.

\*Environmental Control System--Controls spacecraft atmosphere, pressure and temperature and manages water. In addition to regulating cabin and suit gas pressure, temperature and humidity, the system removes carbon dioxide, odors and particles, and ventilates the cabin after landing. It collects and stores fuel cell potable water for crew use, supplies water to the glycol evaporators for cooling, and dumps surplus water overboard through the urine dump valve. Excess heat generated by spacecraft equipment and crew is routed by this system to the cabin heat exchangers, to the space radiators, to the glycol evaporators, or it vents the heat to space.

\*Telecommunication System--Consists of pulse code modulated telemetry for relaying to Manned Space Flight Network stations data on spacecraft systems and crew condition, VHF/AM and unified S-Band tracking transponder, air-to-ground voice communications, onboard television, and a VHF recovery beacon. Network stations can transmit to the spacecraft such items as updates to the Apollo guidance computer and central timing equipment, and real-time commands for certain onboard functions.



\*Sequential System--Interfaces with other spacecraft systems and subsystems to initiate critical functions during launch, docking maneuvers, pre-orbital aborts and entry portions of a mission. The system also controls routine spacecraft sequencing such as Service Module separation and deployment of the Earth landing system.

\*Emergency Detection System--Detects and displays to the crew launch vehicle emergency conditions, such as excessive pitch rates or two engines out, and automatically or manually shuts down the booster and activates the launch escape system; functions until the spacecraft is in orbit.

\*Earth Landing System--Includes the drogue and main parachute system as well as post-landing recovery aids. In a normal entry descent, the Command Module apex cover is jettisoned at 24,000 feet, followed by two mortar-deployed reefed 16.5-foot diameter drogue parachutes for orienting and decelerating the spacecraft. After drogue release, three pilot chutes pull out the three main 83.3-foot diameter parachutes with two-stage reefing to provide gradual inflation in three steps. Two main parachutes out of three will provide a safe landing. Recovery aids include the uprighting system, swimmer interphone connections, sea dye marker, flashing beacon, VHF recovery beacon and VHF transceiver. The uprighting system consists of three compressor-inflated bags to turn the spacecraft upright if it should land in the water apex down (Stable II position).

\*Caution and Warning System--Monitors spacecraft systems for out-of-tolerance conditions and alerts crew by visual and audible alarms so that crewmen may trouble-shoot the problem.

\*Controls and Displays--Provide readouts and control functions of all other spacecraft systems in the command and service modules. All controls are designed to be operated by crewmen in pressurized suits. Displays are grouped according to the frequency the crew refers to them.

# CM UNIFIED CREW HATCH

## BLOCK II

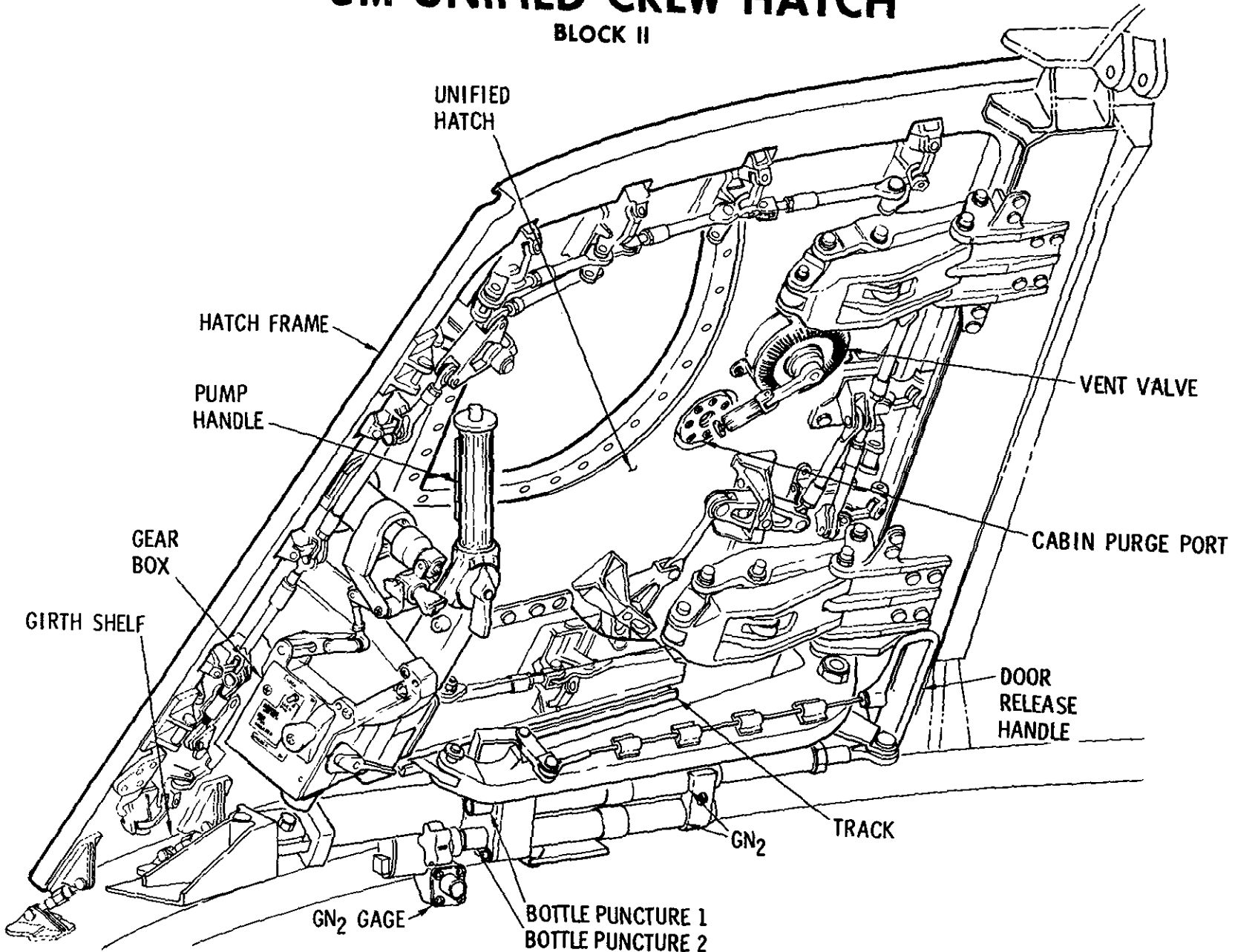

-more-

-28a-

### Spacecraft Design Changes, Materials Substitution

Numerous hardware and operational procedures changes in the Apollo spacecraft have been made in the 18 months since the Apollo 204 fire which killed the prime crew of the first programmed manned Apollo mission.

A single quick-operating, outward opening crew hatch has replaced the earlier two-piece hatch. The new aluminum and fiberglass hatch can be opened from inside in seven seconds and by a pad safety crew in 10 seconds. Ease of opening is enhanced by a gas-powered counterbalance mechanism.

In order to reduce support of any combustion, launch pad spacecraft cabin atmosphere for pre-launch testing is now a mixture of 60 per cent oxygen and 40 per cent nitrogen instead of the 100 per cent oxygen. The "enriched air," supplied by ground equipment, involved no hardware changes in the spacecraft. The crew suit loops, however, still carry 100 per cent oxygen. After launch, the 60-40 oxygen-nitrogen mix is gradually replaced with pure oxygen until cabin atmosphere reaches 100 per cent oxygen at 5 psi. The enriched air mix was selected after extensive flammability tests in various percentages of oxygen at varying pressures.

Other Apollo spacecraft changes:

- \*Substituting stainless steel for aluminum in high-pressure oxygen tubing.

- \*Armor plating water-glycol liquid line solder joints.

- \*Protective covers over wiring bundles.

- \*Stowage boxes built of aluminum.

- \*Replacement of materials to minimize flammability.

- \*Installation of fireproof storage containers for flammable materials.

- \*Mechanical fasteners substituted for gripper cloth patches.

- \*Flameproof coating on wire connections.

- \*Replacement of plastic switches with metal ones.

- \*Installation of an emergency oxygen system to isolate the crew from toxic fumes.

- \*Inclusion of portable fire extinguisher and fire-isolating panels in the cabin.

APOLLO . . . A COMPARISON

	<u>Mercury</u>	<u>Gemini</u>	<u>Apollo</u>
Length	9 ft. 6 in.	19 ft.	34 ft. 9 in. (CSM only)
Base diameter	6 ft. 6 in.	10 ft.	12 ft. 10 in.
Habitable volume	50 cu. ft.	80 cu. ft.	210 cu. ft.
Launch weight	3,649 pounds	8,360 pounds	41,358 pounds
Docking	None	Index bar, latches for Agena collar	Probe, docking ring for missions with lunar module
Abort system	Launch escape rocket, malfunction detection system	Pilot ejection seats, malfunction detection system	Launch escape rocket, emergency detection system
Propulsion system	Hydrogen peroxide atti- tude jets, retro rocket motors	Hypergolic orbit atti- tude maneuvering system, retro rockets	Restartable 20,500 lb. thrust service propul- sion engine, separate reaction control system on command and service modules
Available velocity change ( V)	None	750 fps	3,374 fps (Apollo 7)
Electrical power	Storage batteries	Two fuel cells storage batteries	Three large fuel cells rechargeable storage batteries
Communications	Voice, telemetry, radar transponders	Voice, telemetry, rendezvous radar, radar tracking transponders	Voice, telemetry, S-Band for deep space
Parachutes	Drogue, main, reserve	Drogue, pilot, main	2 drogue, 3 pilot, 3 main

THE SATURN IB LAUNCH VEHICLE

The fifth Saturn IB is the 15th in the Saturn I series of launch vehicles. Ten Saturn I and four IB rockets have been launched successfully.

The Saturn IB consists of two propulsive stages and an instrument unit. The first stage is essentially the same as that of Saturn I. For Saturn IB the stage was lightened, strengthened and modified to accept the S-IVB stage, which is larger than the second stage of Saturn I, and the H-1 engines of the first stage were updated. The IB second stage, identical to Saturn V third stage, is an outgrowth of the Saturn I second stage. The instrument units are almost identical on Saturn IB and V.

A "hybrid" vehicle, Saturn IB is capable of delivering about 40,000 pounds of payload to low Earth orbit. In addition to its role as Apollo carrier, it is expected to be used for other manned and unmanned space flights.

The Saturn IB launch vehicle for Apollo 7 will have several innovations. A reduction in the amount of telemetry and instrumentation equipment has reduced vehicle weight and increased the payload capability. (See "Telemetry On AS-205 Launch Vehicle page .) New propellant lines to the augmented spark igniter (ASI) on the J-2 engine of the second stage have been installed.

One important event scheduled for the flight is the launch vehicle propellant dump. This exercise will begin at about 1 hour 34 minutes after liftoff. Propellants remaining in the second stage (S-IVB) after insertion into orbit will be dumped overboard through the J-2 engine. This will prevent any buildup of pressure inside the tanks due to boiloff -- the changing of the cryogenic liquids to gases, with the accompanying expansion. This "orbital safing" of the stage will avert a possible rupture of the tanks while the stage is attached to the Apollo command service module, or while it is close to the CSM following rendezvous with the stage later in the flight. The rendezvous is one of the primary objectives of the flight.

The astronauts, about 2.5 hours after liftoff, will begin manual control of the vehicle from their stations inside the spacecraft. After 25 minutes, control will be returned to the launch vehicle instrument unit. The spacecraft will be separated from the second stage about two hours 55 minutes after launch.

# SATURN IB CUTAWAY

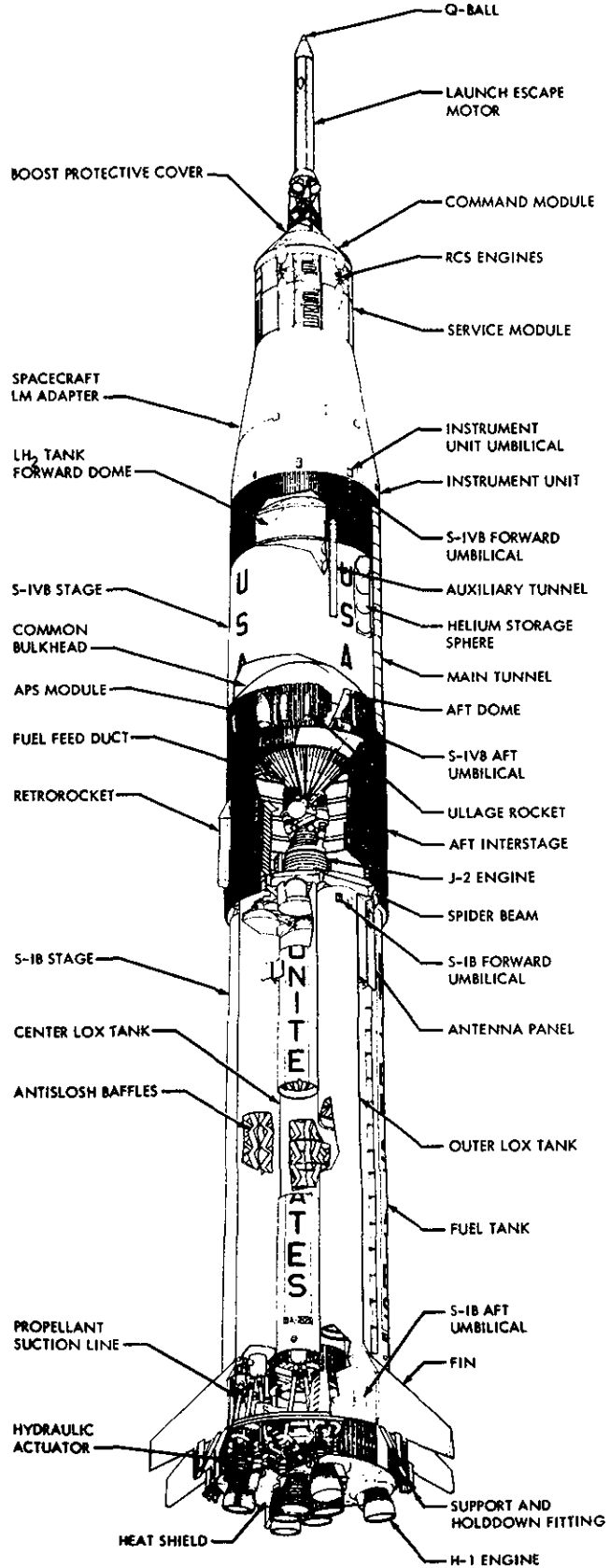

FIRST STAGE -- The Saturn IB booster (S-IB) is 80.2 feet long and 21.5 feet in diameter. Dry weight of the redesigned booster is 84,401 pounds, about 10 tons lighter than the Saturn I booster (S-I).

The stage has eight 70 in. diameter tanks clustered around a center tank 105 inches in diameter. Four of the outer tanks and the center tank contain liquid oxygen. The other four tanks, alternating with the LOX tanks, contain kerosene (RP-1) fuel. Eight Rocketdyne H-1 engines provide a total thrust of 1.6 million pounds.

The engines are mounted on the thrust structure. The four outboard engines are equipped with independent, closed-loop hydraulic systems which gimbal the engines as much as eight degrees for vehicle flight direction control.

In about 2.5 minutes of operation, the stage burns about 42,000 gallons (277,000 pounds) of fuel and 67,000 gallons (631,000 pounds) of oxidizer to reach an altitude of about 33 nm (38 sm, 61 km) at engine cutoff.

The stage has eight fins equally spaced around the tail unit assembly to increase aerodynamic stability in the lower atmosphere. The fins also support the vehicle on the launch pad and provide tiedown points for restraint momentarily after ignition.

Equipment on the S-IB stage includes the propulsion system, the hydraulic system, a control pressure system, purge systems, a fire detection and water quench system, a flight termination or "destruct" system, electrical power, instrumentation, and telemetry systems.

Chrysler assembles S-IB stages at NASA's Michoud Assembly Facility, New Orleans and tests them at the NASA's Marshall Space Flight Center, Huntsville, Ala.

SECOND STAGE -- The S-IVB stage is 58.4 feet long and 21.7 feet in diameter. One Rocketdyne J-2 engine powers the stage. Empty weight of the stage is 21,909 pounds.

The cylindrical stage has a liquid hydrogen tank and a liquid oxygen tank. The tanks are separated by a common bulkhead which isolates the hydrogen about minus 423 degrees F and oxygen about minus 297 degrees F. The common bulk head is of honeycomb construction for strength and insulation.

The J-2 engine produces thrust of 200,000 pounds for about 7.5 minutes of operation. It will burn some 64,000 gallons (37,000 pounds) of liquid hydrogen and some 20,000 gallons (193,000 pounds) of LOX.

One-piece, stronger propellant lines have replaced lines with flex joints that feed the augmented spark igniter inside the injector of the J-2 engine. Analysis of data on the second Saturn V flight indicated leaks in the igniter propellant lines of two J-2 engines -- one on the second stage and one on the third. Extensive ground testing led to a redesign and "beefing up" of these lines. The redesigned line, thoroughly tested on the ground, is being flight tested for the first time in Apollo 7.

The stage is made up of propulsion and hydraulic systems, a control pressure system, a flight termination system, electrical power supply and distribution system, and an instrumentation and telemetry system.

The S-IVB stage is connected to the first stage by an aft interstage. The separation sequence starts immediately after first stage outboard engines cut off. The stages separate by simultaneous operations of an ordnance system which severs the separation joint; four retromotors which slow the first stage; and three ullage rockets, which impart a slight acceleration to the S-IVB stage and payload.

McDonnell Douglas Corp. builds the S-IVB at Huntington Beach, Calif., and tests it at the Sacramento Test Center.

**INSTRUMENT UNIT** -- The 4,280-pound instrument unit is a cylinder three feet high and 260 inches in diameter. It contains electrical and mechanical equipment which guides, controls and monitors vehicle performance from liftoff until after insertion of the spacecraft into orbit. It controls first stage powered flight, stage separation, second stage powered flight and orbital flight until the spacecraft is separated.

Equipment includes guidance and control, electrical power supply and distribution, instrumentation, telemetry, radio frequency, command, environmental control, and emergency detection systems.

The instrument unit was designed by the Marshall Center. International Business Machines Corp., Federal Systems Division, is the contractor for fabrication, systems testing and integration and checkout with the launch vehicle. Major elements of the unit come from Bendix, IBM and Electronic Communications, Inc.



LAUNCH VEHICLE TELEMETRY

Instrument Unit

Total Measurements -----200  
Telemetry Systems:  
    1 PCM  
    1 FM/FM  
Tracking System:  
    1 C Band  
    1 Azusa  
Ground Command System (1)

S-IB Stage

Total Measurements -----260  
Telemetry Systems:  
    1 PCM  
    1 FM/FM  
Tracking System:  
    1 ODOF  
Range Safety Systems:  
    2 Secure Command Systems

S-IVB Stage

Total Measurements -----260  
Telemetry Systems:  
    1 PCM  
Range Safety Systems:  
    2 Secure Command Systems

Total Vehicle Measurements -----720

NOTE: The total of 720 measurements is in sharp contrast to the 1,225 taken on the fourth Saturn IB, due to the removal of research and development equipment, leaving only those items required for an "operational" vehicle. Tape recorders have been removed. Telemetry systems were reduced by two in the instrument unit, two in the first stage and four in the second stage. Tracking and secure command systems remain the same. Removal of equipment reduced the number of events to be monitored and reduced total vehicle weight, making possible an increase in payload capability.

-more-

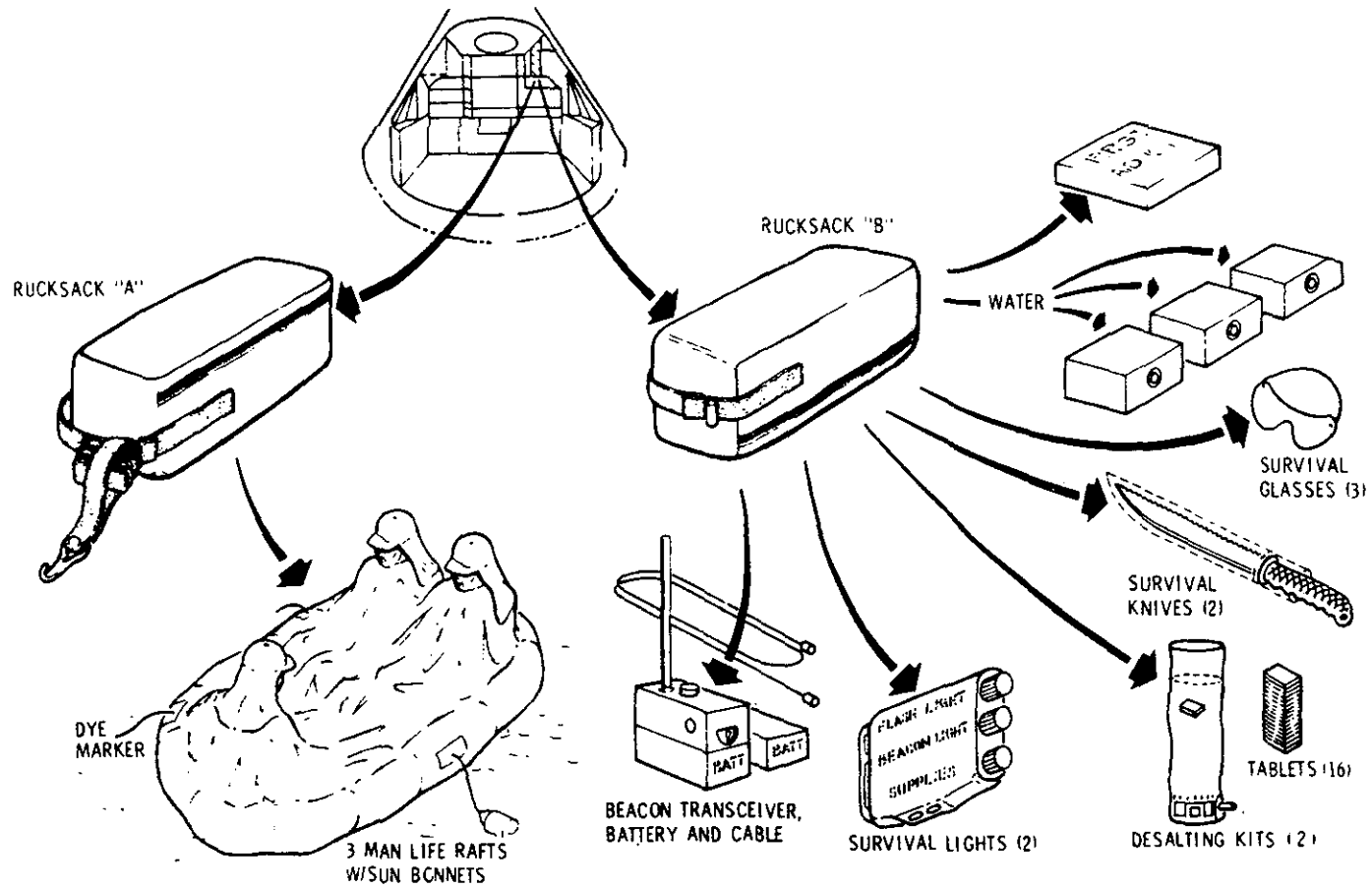

-34a-

SURVIVAL KIT AND COMPONENTS

FLIGHT SEQUENCE

HOURS	MINUTES	SECONDS	EVENT
00	00	00	Liftoff
00	00	10	Pitch and Roll maneuver initiated
00	00	38	Roll Terminated
00	01	15	Maximum dynamic pressure (altitude 7.6 miles, about 2.4 miles downrange, velocity 1,660 mph)
00	02	14	Pitch terminated
00	02	20	First stage inboard engines cutoff
00	02	23	First stage outboard engines cutoff (altitude 37.6 miles, 37 miles downrange, velocity 5,201 mph)
00	02	24	Second stage ullage rocket ignition, separation signal
00	02	24	First Stage separates
00	02	26	J-2 engine start command
00	02	28	90 percent J-2 thrust level
00	02	43	Crew jettisons launch escape system
00	02	48	Initiate active guidance
00	10	15	Guidance signal cutoff, second stage engine cutoff (altitude 141.6 miles, 1,130.9 miles downrange, velocity 17,405.4 mph)
00	10	25	Insertion into orbit (altitude 141.7 miles, 1,175.2 miles downrange, velocity 17,420.4 mph)

-more-

HOURS	MINUTES	SECONDS	EVENT
01	34	6	Begin orbital safing of vehicle. Dump pressurant and propellants (Altitude 142 miles, 1,617.9 miles west of KSC, velocity 17,418.4 mph)
02	29	55	Begin manual crew control of vehicle from spacecraft (altitude 190.4 miles, 11,928.6 miles west of KSC, velocity 17,240.3 mph)
02	54	55	Spacecraft-launch vehicle sepa- ration (150.1 miles altitude, 5,436.3 miles west of KSC, velo- city 17,403.2 mph)

-more-

### LAUNCH PREPARATIONS

Pre-launch checkout and the countdown for Apollo 7 are conducted by a government-industry team headed by NASA's Kennedy Space Center. The Launch Control Center in the Complex 34 blockhouse will be manned by a crew of about 250 during the final countdown.

The two propulsion stages and the instrument unit of the Saturn IB launch vehicle were erected at Complex 34 in April. KSC crews conducted a series of preliminary tests with the individual stages prior to electrical mate and integrated systems tests of the overall vehicle.

The Apollo 7 Command and Service Modules arrived at KSC in May. Preliminary checkout of spacecraft systems was conducted at the Manned Spacecraft Operations Building. The two Modules were mated in the MSOB vacuum chamber for a series of unmanned and manned altitude runs. The prime crew and the backups each participated in one of the altitude runs before the spacecraft was mated to its adapter and taken to Complex 34. The spacecraft was mated to the launch vehicle at the pad in August. The initial mating was mechanical, followed by an electrical mating some three weeks later. When this was accomplished, overall tests of the space vehicle were ready to begin.

Tests of the integrated launch vehicle and spacecraft followed. The launch escape tower was mated and a series of simulated missions were performed. Several of the runs were conducted with the launch pad umbilicals connected. One major test was made with umbilicals disconnected in a complete launch mission on the ground -- a "Plugs Out Test" -- with the prime crew in the spacecraft with hatch open.

A Countdown Demonstration Test was conducted about four weeks prior to the scheduled launch date. This is a complete dress rehearsal of the countdown. It is divided into "wet" and a "dry" test. The "wet" test encompassed the entire countdown, including the fueling, but the astronauts did not board the spacecraft. The "dry" portion picked up the countdown shortly before propellant loading. This time the loading was simulated and the flight crew participated as it would on launch day.

About two weeks before the scheduled launch date a Flight Readiness Test is conducted to exercise the launch vehicle and spacecraft systems. The Mission Control Center, Houston, participates in this test with the KSC launch team.

Following a data review of the Flight Readiness Test, hypergolic propellants are loaded aboard the Apollo spacecraft and the Auxiliary Propulsion System propellants aboard the second stage (S-IVB), and the system is static fired. RP-1, the fuel for the first stage, is brought aboard prior to picking up the precount at about T-102 hours.

Automatic checkout, utilizing RCA-110A computers, plays a major role in checkout and countdown preparations for both the launch vehicle and spacecraft. Computer functions for the launch vehicle are located in the blockhouse and at the automatic ground control station at the launch pad. Spacecraft checkout, centralized at the KSC Manned Spacecraft Operations Building, is controlled by a computer complex known as Acceptance Checkout Equipment. The use of the computers enables the launch crews to receive rapid readouts on launch vehicle and spacecraft systems during the checkout and countdown.

The final countdown for Apollo 7 will begin at T-14 hours 15 minutes, when power is applied to the Saturn IB launch vehicle. A planned six-hour built-in hold is scheduled at T-6 hours, before final propellant loading. Liftoff is scheduled for 11 a.m. EDT.

A pre-count operation begins at T-five days to cover an extensive series of preparatory tasks with the spacecraft. These include checks of the environmental control system, stabilization control system, guidance and navigation system, and water servicing of the spacecraft. Pyrotechnic devices are installed and mechanical closeout of the spacecraft accomplished. Helium servicing is performed, followed by fuel cell activation at T-32:30 hours. Cryogenic loading (bringing aboard the liquid oxygen and liquid hydrogen) extends from T-27:30 to T-21:30 hours.

Launch vehicle preparations in the precount include radio frequency and telemetry checks, and installation of ordnance and the flight batteries.

Following are highlights of the final countdown:

T-14:15 hours	-- Power up launch vehicle
T-13:00	-- Mission Control Center Houston, launch vehicle command checks
T-10:55	-- Range Safety command checks
T-9:30	-- Launch vehicle ordnance operations

T-9:00 -- Backup command module pilot (John Young) and backup lunar module pilot (Eugene Cernan) enter spacecraft

T-6:50 -- Move service structure to park-site

T-6:00 -- Six hour built in hold

T-6:00 -- Pad area cleared. Resume count. Begin LOX loading, first and second stages.

T-4:30 -- Lox loading complete. Begin liquid hydrogen loading, second stage.

T-3:10 -- Liquid hydrogen loading complete

T-3:00 -- Closeout crew returns to spacecraft White Room

-- Prime crew departs quarters at Manned Spacecraft Operations Building

T-2:25 -- Prime crew begins spacecraft ingress

T-1:50 -- Abort advisory system checks

T-1:25 -- Space vehicle emergency detection system test

T-1:10 -- Range Safety tracking checks

T-50 minutes -- Begin terminal count phase

T-45 -- Activate launch vehicle radio frequency and telemetry

T-40 -- Clear pad area

T-39 -- Final Houston launch vehicle command checks

T-33 -- Retract Apollo access arm to standby position. Arm Launch Escape System

T-31 -- Launch vehicle power transfer test

T-28 -- Final launch vehicle Range Safety command checks

T-25 -- Pressurize spacecraft reaction control system (RCS)

T-20 -- Spacecraft RCS static fire

-more-

T-15	-- Spacecraft to internal power
T-6	-- Final Go-No Go status check
T-5	-- Apollo access arm to full retract position
T-2:43	-- Begin automatic launch sequence
T-28 sec.	-- Launch vehicle to internal power
T-3 sec.	-- First stage ignition
T-0	-- Liftoff

Note: Times are subject to change prior to launch.

-more-



### LAUNCH COMPLEX 34

Launch Complex 34 is located at the north end of Cape Kennedy and covers approximately 77 acres. Major features on the Complex include the launch pad and pedestal, an umbilical tower, a service structure mounted on rails which moves back to a parked position about 600 feet from the pad at launch, a launch control center (blockhouse), an automatic ground control station, propellant facilities, and an operations support building.

Construction at Complex 34 was completed in time for the first Saturn I launch, Oct. 27, 1961. The first four launches in the Saturn development program took place there, the fourth one on Mar. 28, 1963. The last six Saturn I's were launched at Complex 37, north of 34.

Since its final test at Complex 34, the pad was modified for launching the Saturn IB. In addition, hurricane gates have been installed on the service structure so that a launch vehicle could ride out hurricane force winds without being taken to a hangar area.

### SAFETY CHANGES

Preparations were in progress for the first manned Apollo flight at Complex 34 when a fire in the spacecraft took the lives of Astronauts Virgil I. Grissom, Edward H. White, II and Roger B. Chaffee Jan. 27, 1967. The accident occurred in the "plugs out" test.

As a result of review board recommendations, a number of changes were made at Complex 34, including structural modifications to the white room for the new quick-opening spacecraft hatch, improved firefighting equipment, emergency egress routes and emergency access to the spacecraft.

A number of other safety features have been added. All electrical equipment in the white room is now purged with nitrogen. A hand-held water hose is available for fire fighting and a large exhaust fan draws smoke and fumes from the white room. The room is covered with a fire-resistant paint. Certain structural members have been moved to provide easier access to the spacecraft and faster egress.

A water spray system was added which would cool the launch escape system positioned above the command module, in the event of fire. The launch escape system contains solid propellants which could be ignited by extreme heat. Additional water spray systems were installed along the egress route from the spacecraft to ground level.

The primary mode of emergency egress for astronauts and technicians during the final phase of the countdown is the high-speed elevator which is set to run nonstop from the 220-foot level of the umbilical tower to the ground. A slide-wire system provides an alternate means of quick exit; this would be used for immediate escape from the pad area. The 1,200-foot slide-wire, attached at the 220-foot level, takes only 30 seconds to carry a man to the edge of the launch complex.

#### Complex 34 Data

The launch pad is 430 feet in diameter. Part of the pad is covered with refractory brick that minimizes damage from the rocket exhaust. The surface is 16 feet above sea level.

The 42-foot-square, reinforced concrete launch pedestal, located in the center of the pad, provides a platform for the launch vehicle and certain ground support equipment. It is 27 feet high. Plate steel covers all surfaces exposed to rocket flame which is exhausted through an opening 25 feet in diameter to a deflector below. This opening also provides access to the first stage engines. Eight hold-down arm assemblies are bolted around this opening to anchor the launch vehicle to the top of the pedestal. The hold-down arms are released after full thrust for liftoff is reached by the first stage engines.

The launch team, instrumentation, and control equipment connected with launch activities are housed in the blockhouse, which also provides blast protection for personnel and equipment.

The blockhouse is a two-story, reinforced concrete igloo-type building located 1,000 feet from the launch pad. Its walls vary from 7 feet thick at the top of the dome to 30 feet at the base. The building contains 11,650 square feet of space and is designed to withstand blast pressures of 2,188 pounds per square inch.

The first floor houses one of the RCA-110A computers used for automatic checkout, and personnel involved in tracking, telemetry, closed-circuit television, communication, etc. Launch control and the various monitoring and recording consoles are located on the second floor.

-42a-

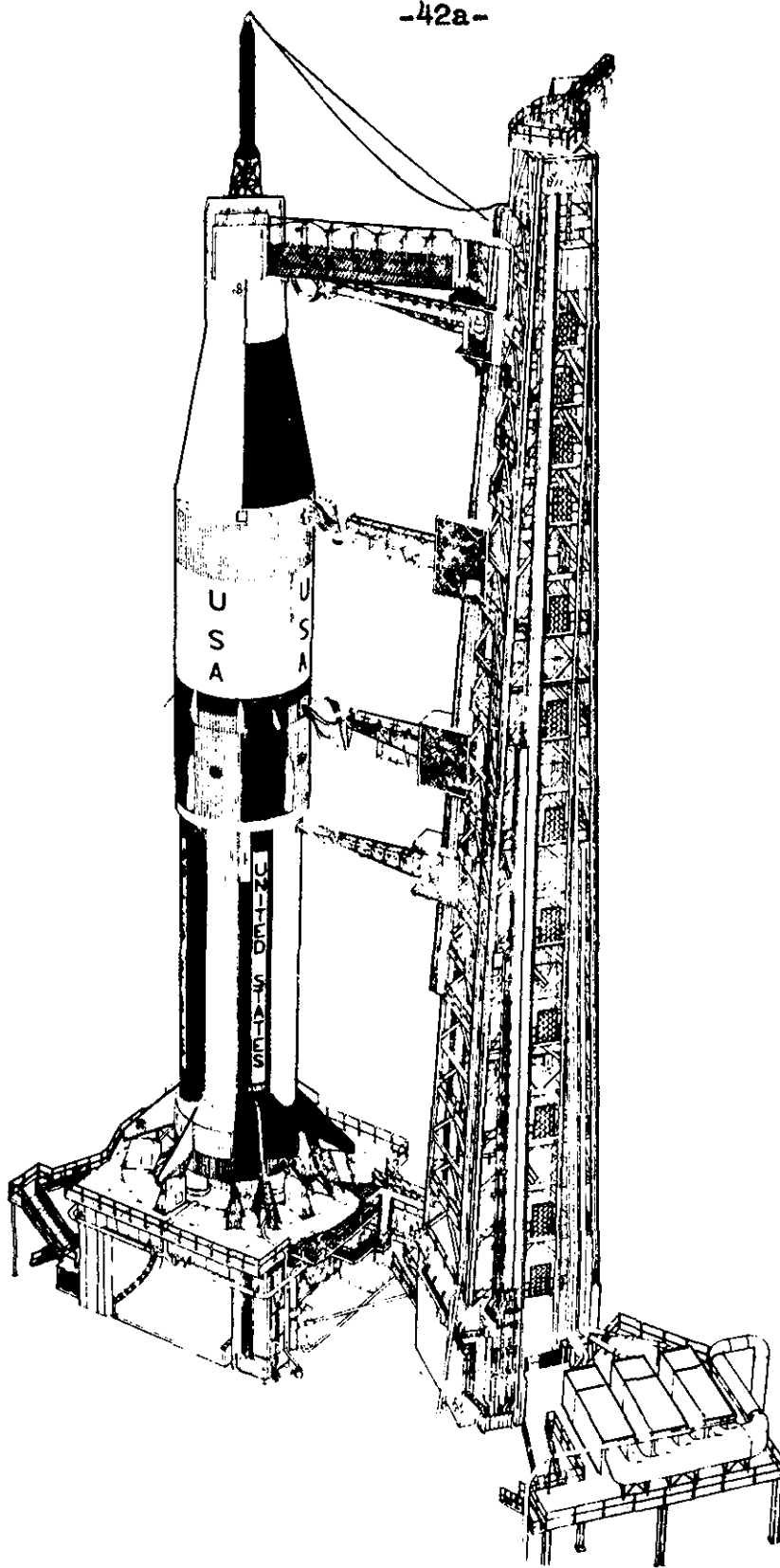

APOLLO 7 SPACE VEHICLE AND UMBILICAL TOWER

-more-

# LAUNCH COMPLEX 34

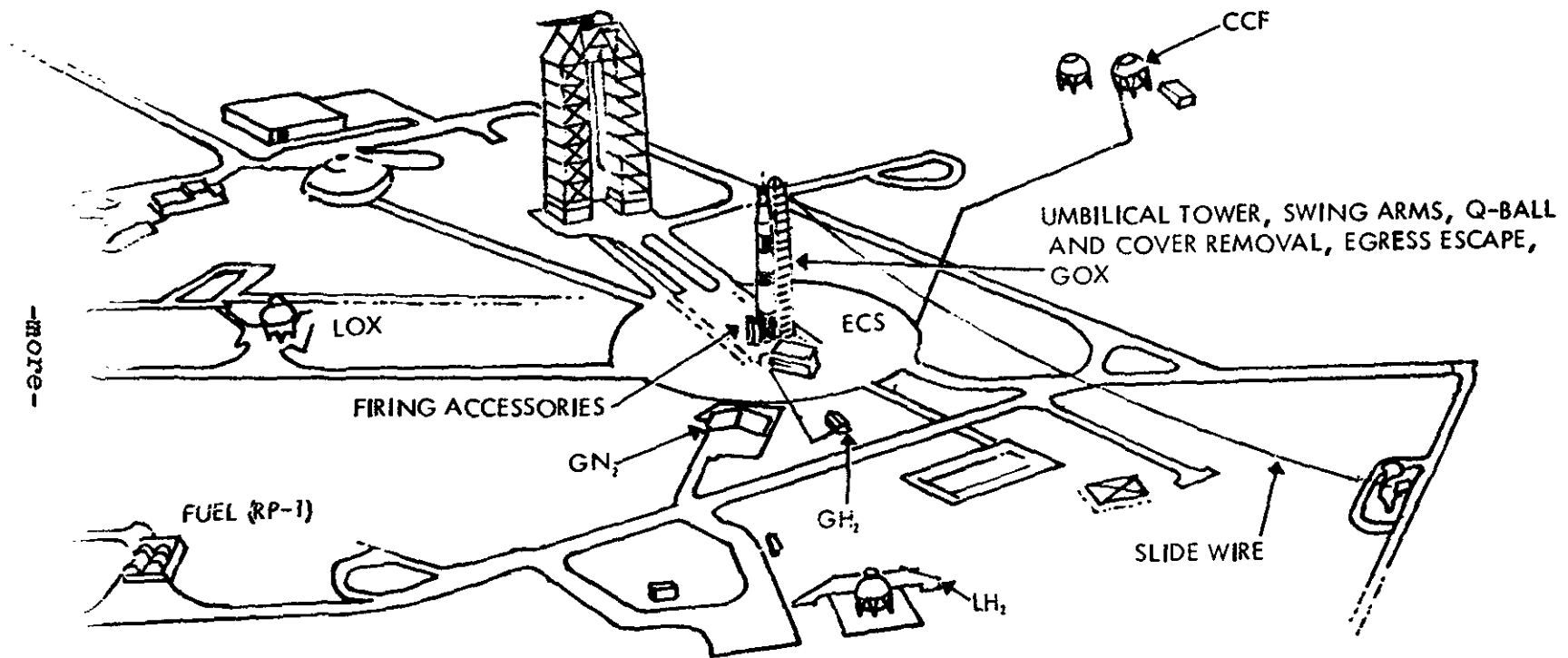

The service structure, a movable steel framework used during vehicle erection, assembly and checkout, provides work platforms for personnel, cranes for lifting rocket stages and spacecraft into place on the launch pedestal, and protection from the weather for both the space vehicle and launch personnel. The inverted U-shaped structure rises 310 feet above the launch pad, and its base measures 70 by 130 feet.

There are four elevators and seven fixed work platforms at various levels within the structure legs. Eight enclosed platforms can be extended to the vehicle from the tower. The launch escape system for the Apollo spacecraft is reached from two additional work platforms located near the top of the service structure.

The 3,552-ton service structure moves on four 12-wheel trucks along a special dual track railway within the complex. At the launch pad, support points remove the service structure from the trucks and anchor it to the ground. Before the rocket is launched, the service structure is moved to its parking position some 600 feet away from the pedestal. A 500-kva diesel-electric generator, enclosed in the base, powers the 100-horsepower traction motors in each truck.

The 240-foot umbilical tower at Complex 34 is a steel-trussed structure with four swing arms attached to the space vehicle from the joints. Each swing arm carries links between the space vehicle and tower which lead to ground-based power, air conditioning, hydraulic, pneumatic, fuel, measuring, and command systems.

At the 220-foot level is the Apollo spacecraft access arm. Astronauts go to and from the spacecraft through this access arm, which is connected to the white room. The umbilical elevator, which can move 450 feet-per-minute, is the astronauts' prime emergency escape.

Service facilities store and transfer RP-1 fuel to the launch vehicle's first stage under remote control of the automatic-semi-automatic system. The two cylindrical RP-1 storage tanks, measuring 41 feet long, 11 feet in diameter, have a total capacity of 60,000 gallons-per-minute and a slow-fill rate of 200 gallons-per-minute. The system has facilities for filtration and water separation.

Liquid hydrogen fuel to the second stage of the Saturn IB is stored and transferred at minus-423 degrees F. The remotely-controlled facility, also automatic-semi-automatic, has a 125,000-gallon storage capacity in a double-walled, vacuum-insulated spherical tank 38 feet in diameter. It is insulated by perlite, a glassy volcanic rock. The system has a transfer capability of 3,000 gallons-per-minute, a replenish rate of 0 to 200 gallons, and a fine-fill rate of 500 gallons. One hydrogen burn pond, located near the storage area, disposes of vented gas from the storage tank and part of the transfer line system. A second burn pond, located adjacent to the launch pad, is used to dispose of hydrogen vented from the vehicle, the helium heat exchange, and the remainder of the transfer line.

Liquid oxygen is stored and transferred at minus-297 degrees F, for the Saturn's first and second stages. The main 125,000 gallon tank is a double-walled sphere with an outside diameter of 41.25 feet. A 4-foot separation between the inner and outer tanks is filled with expanded perlite and pressurized with gaseous nitrogen. The 11-foot diameter, cylindrical, perlite-insulated, replenishing tank holds 13,000 gallons. LOX is transferred by three pumps: a 2,500-gallon-per-minute pump for filling the first stage, a 1,000 gallon one for filling the second stage, and one of 1,000 gallons capacity for transferring LOX from the main tank into the replenish tank. The fast-fill, slow-fill, and replenish rates for servicing the first stage are 2,500, 500 and 0-50 gallons per minute, respectively.

For the second stage, the fast-fill, slow-fill rates are 1,000, 300, and 0-10 gallons, respectively. Initiation and control of the tanking and replenishing operations are accomplished and monitored from the control center during launch operations.

MISSION CONTROL CENTER-HOUSTON

The Mission Control Center at the Manned Spacecraft Center, Houston, is the focal point for all Apollo flight control activities. The Center will receive tracking and telemetry data from the Manned Space Flight Network. These data will be processed through the Mission Control Center Real-Time Computer Complex and used to drive displays for the flight controllers and engineers in the Mission Operations Control Room and staff support rooms.

The Manned Space Flight Network tracking and data acquisition stations link the flight controllers at the Center to the spacecraft.

For Apollo 7, all stations will be remoted sites without flight control teams. All uplink commands and voice communications will originate from Houston, and telemetry data will be sent back to Houston at high speed (2,400 bits per second). They can be either real time or playback information.

Signal flow for voice circuits between Houston and the remote sites is via commercial carrier, usually satellite, wherever possible using leased lines which are part of the NASA Communications Network.

Commands are sent from Houston to NASA's Goddard Space Flight Center, Greenbelt, Md., lines which link computers at the two points. The Goddard computers provide automatic switching facilities and speed buffering for the command data. Data are transferred from Goddard to remote sites on high speed (2,400 bits per second) lines. Command loads also can be sent by teletype from Houston to the remote sites at 100 words per minute. Again, Goddard computers provide storage and switching functions.

Telemetry data at the remote site are received by the RF receivers, processed by the Pulse Code Modulation ground stations, and transferred to the 642B remote-site telemetry computer for storage. Depending on the format selected by the telemetry controller at Houston, the 642B will output the desired format through a 2010 data transmission unit which provides parallel to serial conversion, and drives a 2,400 bit-per-second modem. The data modem converts the digital serial data to phase-shifted keyed tones which are fed to the high speed data lines of the Communications Network.

Telemetry summary messages can also be output by the 642B computer, but these messages are sent to Houston on 100-word-per-minute teletype lines rather than on the high speed lines.

Tracking data are output from the sites in a low speed (100 words) teletype format and a 240-bit block high speed (2,400 bits) format. Data rates are 1 sample-6 seconds for teletype and 10 samples (frames) per second for high speed data.

All high speed data, whether tracking or telemetry, which originate at a remote site are sent to Goddard on high speed lines. Goddard reformats the data when necessary and sends them to Houston in 600-bit blocks at a 40,800 bits-per-second rate. Of the 600-bit block, 480 bits are reserved for data, the other 120 bits for address, sync, intercomputer instructions, and poly-nominal error encoding.

All wideband 40,800 bits-per-second data originating at Houston are converted to high speed (2,400 bits-per-second) data at Goddard before being transferred to the designated remoted site.

-more-



## MANNED SPACE FLIGHT NETWORK

The Manned Space Flight Tracking Network for Apollo 7, consisting of 14 ground stations, four instrumented ships and five instrumented aircraft, is working its first manned flight. It is the global extension of the monitoring and control capability of the Mission Control Center in Houston. The network, developed by NASA through the Mercury and Gemini programs, now represents an investment of some \$500 million and, during flight operations, has 4,000 persons on duty. In addition to NASA facilities, the network includes facilities of the Department of Defense and the Australian Department of Supply.

The network was developed by the Goddard Space Flight Center under the direction of NASA's Associate Administrator for Tracking and Data Acquisition.

Basically, manned flight stations provide one or more of the following functions for flight control:

1. Telemetry;
2. tracking;
3. commanding, and
4. voice communications with the spacecraft.

Apollo missions require the network to obtain information -- simultaneously -- instantly recognize it, decode it, and arrange it for computer processing and display in the Houston Control Center.

Apollo generates much more information than either Mercury or Gemini did, so data processing and display capability are needed. Apollo also requires network support at both Earth orbital and lunar distances. The Apollo Unified S-Band System (USB) provides this capability.

### Network Support Team - Goddard

The 30-man network support team mans the various communications positions at the Manned Space Flight Operations Center. The team is comprised of technical and operational personnel required by the Network Director, Network Operations Manager and Network Controller to assist in operating the network around the clock and coordinating its activities.

# MANNED SPACE FLIGHT NETWORK

(Apollo 7)

-47a-

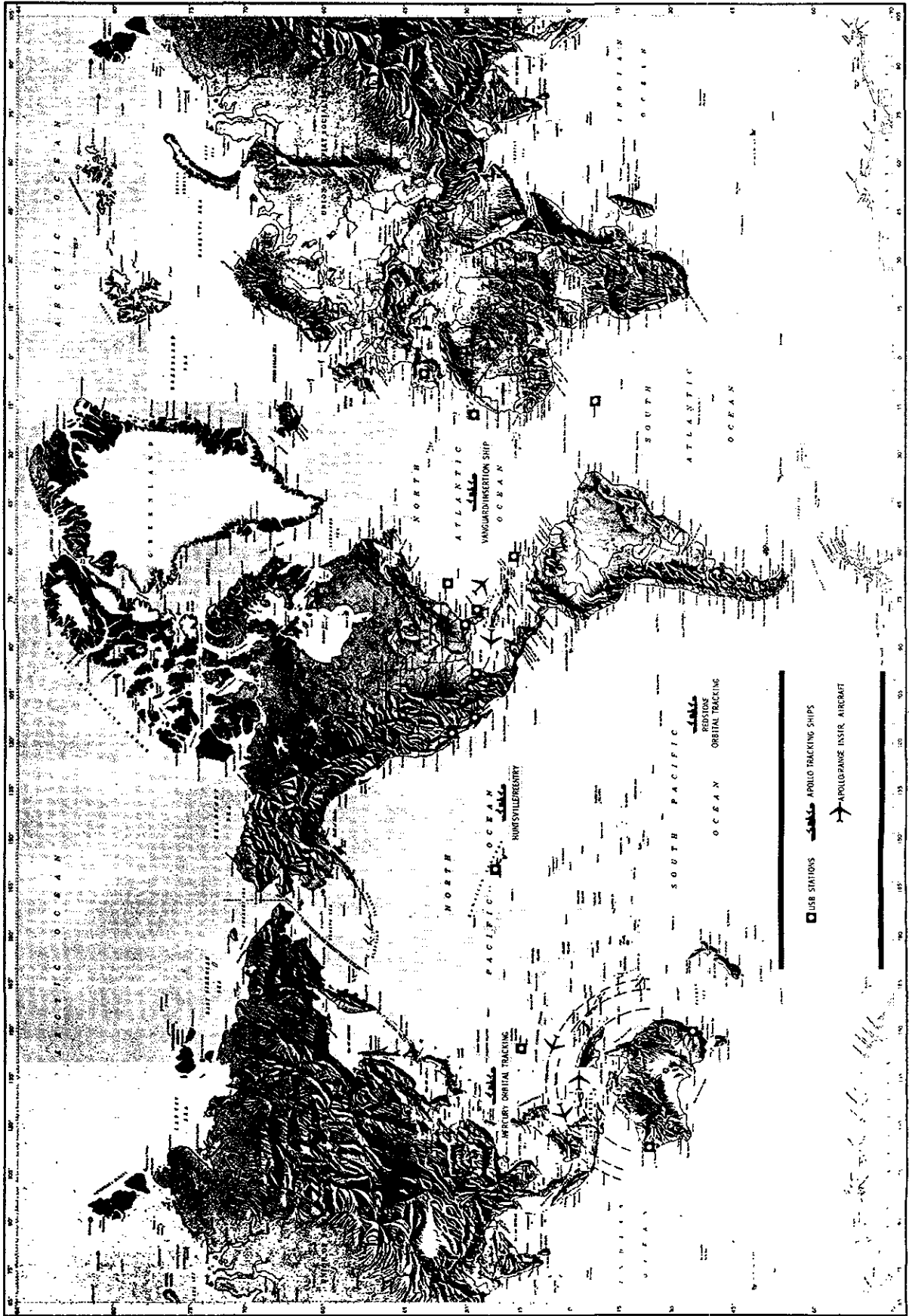

-more-

The team coordinates network communications and provides the Network Operations Manager and Network Controller with the necessary technical assistance and monitoring capability. The Network Support Team also is responsible for communicating with non-NASA facilities for assistance not available in the network.

As in Apollo 6 the network stations, launch site, and control and communications centers will be connected through the two million miles of communications circuitry of the NASA Communications Network.

#### NASA Communications Network - Goddard

This network consists of several systems of diversely routed communications channels leased on communications satellites, common carrier systems and high frequency radio facilities where necessary to provide the access links.

The system consists of both narrow and wide-band channels, and some TV channels. Included are a variety of telegraph, voice and data systems (digital and analog) with a wide range of digital data rates. Wide-band and TV systems do not extend overseas. Alternate routes or redundancy are provided for added reliability in critical mission operations.

A primary switching center and intermediate switching and control points are established to provide centralized facility and technical control, and switching operations under direct NASA control. The primary switching center is at Goddard, and intermediate switching centers are located at Canberra, Australia; Madrid, Spain; London, England; Honolulu, Hawaii; Guam and Cape Kennedy, Fla.

For Apollo 7, Cape Kennedy is connected directly to the Mission Control Center, Houston, by the communication network's Apollo Launch Data System, a combination of data gathering and transmission systems designed to handle launch data exclusively.

After launch all network and tracking data are directed to the Mission Control Center, Houston, through Goddard. A high-speed data line (2,400 bits-per-second) connects Cape Kennedy to Goddard, where the transmission rate is increased to 40,800 bits-per-second from there to Houston. Upon orbital insertion, tracking responsibility is transferred between the various stations as the spacecraft circles the Earth.

Two Intelsat communications satellites will be used for Apollo 7, one positioned over the Atlantic Ocean in an equatorial orbit varying about six degrees N. and S. latitude and six degrees W. longitude. The Atlantic satellite will service the Ascension Island USB station, the Atlantic Ocean ship and the Canary Island site.

Only two of these three stations will be transmitting information back to Goddard at any one time, but all four stations can receive at all times.

The second Apollo Intelsat communications satellite is located about 170 degrees E. longitude over the mid-Pacific near the Equator at the international dateline. It will service the Carnarvon, Australian USB site and the Pacific Ocean ships. All these stations will be able to transmit simultaneously through the satellite to Houston via Brewster Flat, Wash., and the Goddard Space Flight Center.

### Network Computers

At fraction-of-a-second intervals, the network's digital data processing systems, with NASA's Manned Spacecraft Center as the focal point, "talk" to each other or to the astronauts in real time. High speed computers at the remote sites (tracking ships included) issue commands or "up" data on such matters as control of cabin pressure, orbital guidance commands, or "go-no-go" indications to perform certain functions.

In the case of information originating from Houston, the computers refer to their pre-programmed information for validity before transmitting the required data to the capsule.

Such "up" information is communications by ultra-high frequency radio about 1,000 bits-per-second. Communication between remote ground sites, via high-speed communications links, occurs about the same rate. Houston reads information from these ground sites at 2,000 bits-per-second, as well as from remote sites at 100 words-per-minute.

The computer systems perform many other functions, including:

- \* Assuring the quality of the transmission lines by continually exercising data paths.
- \* Verifying accuracy of the messages by repetitive operations.
- \* Constantly updating the flight status.

# NASCOM (Apollo 7)

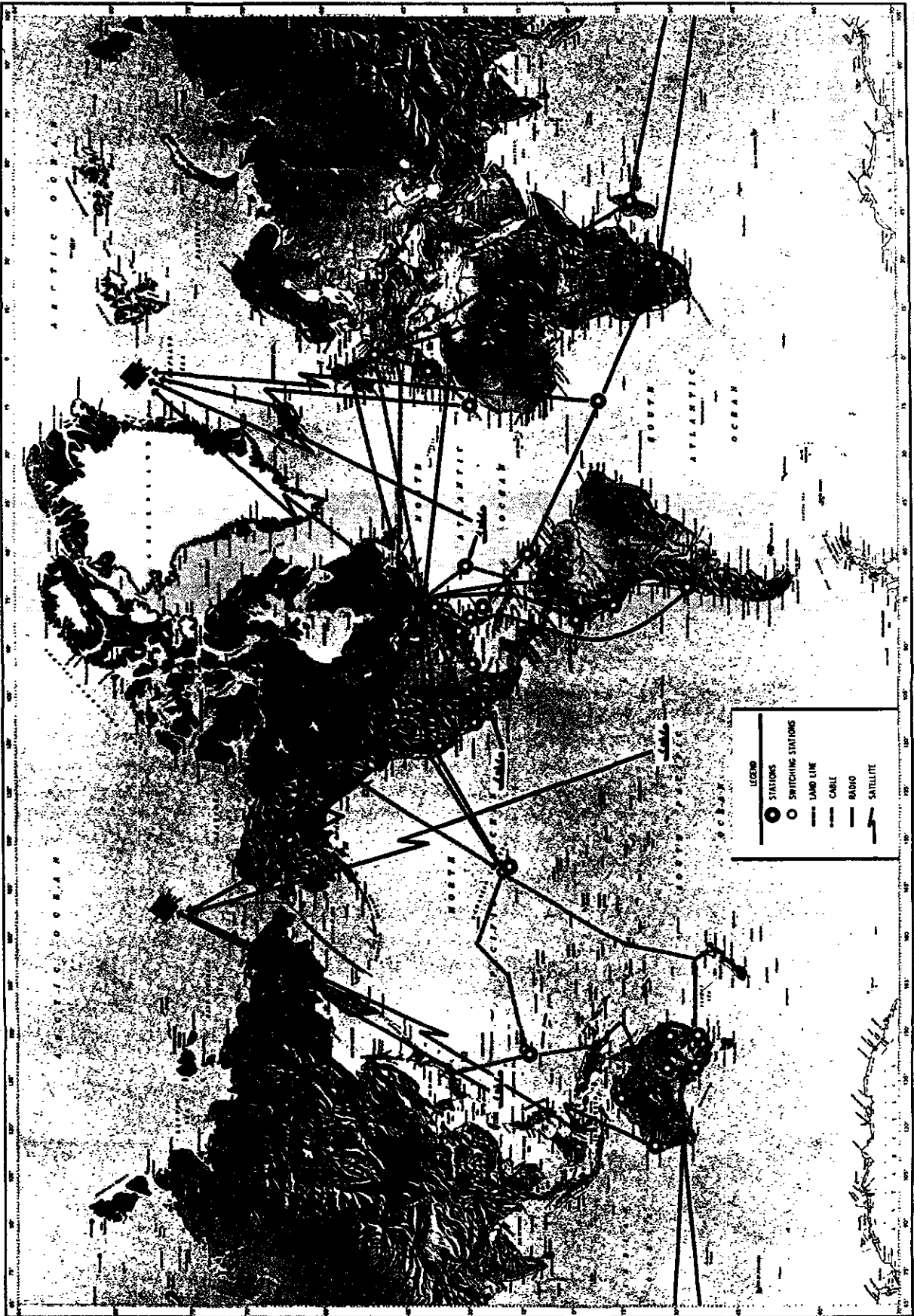

NASA HQ TWP-1539  
9-11-68

For "down" data, sensors built into the spacecraft continually sample cabin temperature, pressure, physical information on the astronauts such as heartbeat and respiration, among other items. These data are transmitted to the ground stations at 51.2 kilobits (12,800 binary digits) per second.

The computers then:

- \* Detect and select changes or deviations, compare with their stored programs, and indicate the problem areas or pertinent data to the flight controllers.
- \* Provide displays to mission personnel.
- \* Assemble output data in proper formats.
- \* Log data on magnetic tape for replay.
- \* Provide storage for "on-call" display for the flight controllers.
- \* Keep time.

Fourteen land stations are outfitted with computer systems to relay telemetry and command information between Houston and Apollo spacecraft: Canberra and Carnarvon, Australia; Guam; Kauai, Hawaii; Goldstone, Calif; Corpus Christi, Tex.; Cape Kennedy; Grand Bahama Island; Bermuda; Madrid; Grand Canary Island; Antigua; Ascension Island; and Guaymas, Mex.

#### Network Testing

Although the network operators and equipment are under regular testing exercises, approximately 14 days before a planned launch, each system and subsystem in the network undergoes nearly continuous testing and checking.

Each system and subsystem at each station has its own performance criteria. At Goddard these criteria are stored in a computer memory system. Each station reports its own system-by-system checks via high-speed digital circuits. By comparing these reports automatically with the stored values, any variation from the desired, the computer reports a "no-go" condition. If there is no variation from what is expected there is a "go". The process is repeated until the test conducted finds the entire network ready. Normally some 100 separate system checks are required for a checkout of the net. The procedure, known as Computer and Data Flow Integrated Subsystems Test, is repeated for each mission.

Network Configuration for Apollo 7

Unified S-Band Sites:

NASA 30-Ft. Antenna Sites

Antigua (ANG)  
Ascension Island (ACN)  
Bermuda (BDA)  
Canary Island (CYI)  
Carnarvon (CRO), Australia  
Grand Bahama Island (GBM)  
Guam (GWM)  
Guaymas (GYM), Mexico  
Hawaii (HAW)  
Merritt Island (MIL), Fla.  
Texas (TEX), Corpus Christi

NASA 85-Ft. Antenna Sites

Canberra (CNB), Australia  
(Prime)  
Goldstone (GDS), Calif.  
(Prime)  
Madrid (MAD), Spain (Prime)  
\*Canberra (DSS-42-Apollo Wing)  
(Backup)  
\*Goldstone (DSS-11-Apollo Wing)  
(Backup)  
\*Madrid (DSS-61-Apollo Wing)  
(Backup)

Tananarive (TAN), Malagasy Republic (STADAN station in support role only.)

\*Wings have been added to JPL Deep Space Network site operations buildings. These wings contain additional Unified S-Band equipment as backup to the Prime sites.

### The Apollo Ships

For this mission, four Apollo Instrumentation Ships will serve several purposes in the Manned Space Flight Network. They will support launch abort contingencies, fill gaps in ground station coverage and monitor the early part of the reentry phase.

The Vanguard will be positioned about 1,000 miles east of Bermuda ( $32.7^{\circ}$  N -  $48^{\circ}$  W) and will assist that station in covering orbital insertion, and will supply data in case of an abort.

The ships, Redstone and Mercury, will serve as orbital gap fillers, with Redstone positioned about 3,600 miles south of Los Angeles ( $25^{\circ}$  S -  $118^{\circ}$  W), and Mercury will be located some 90 miles east of Taiwan ( $25^{\circ}$  N -  $125^{\circ}$  E).

The Mercury will be able to support the alternate reentry area in the Pacific Ocean.

The primary tracking function of the Huntsville will be to cover the de-orbit burn phase of reentry. For other parts of the mission, Huntsville will be used for unified S-band telemetry receive and record and astronaut-ground voice re-moting. This ship will be situated about 1,200 miles west of Los Angeles ( $25^{\circ}$  N -  $136^{\circ}$  W).

The ships are operated by civilian Military Sea Transport crews. The instrumentation is operated and maintained by civilian technical crews. These technical crews are trained to NASA specifications and standards, and operate in accordance with NASA-specified procedures in operation, calibration, checkout, maintenance, failure-reporting and modifications control.

Five Apollo Range Instrumentation Aircraft will take part in Apollo 7, two from Patrick Air Force Base, Fla., three from Australia. They are part of a group of eight EC-135A, four-engine jets supplementing land and ship stations in support of Apollo.

The range aircraft provide two-way voice relay between the spacecraft and Mission Control Center, receive and record telemetry signals from the spacecraft and transfer these data to ground stations for relay to mission control.



## NETWORK CONFIGURATION FOR THE APOLLO 7

Systems Facilities	TRACKING			USH			TLM			CMD			Data Processing		Comm			Other		Remarks						
	C-band (high speed)	C-band (low speed)	ODOP	USB	Voice	Command	TLM	VHF Links	FM Remoting	Mag Tape Recording	Decoms	Displays	LHF Commanding	CMD Destruct	DIRL Remoting 642B	642B TLM	642B CMD	High Speed Data	Wideband Data		TTY	Voice (SCAMA)	Voice U.H.F.	Riometer	SPAN	
PAT CNV	2	2	1										1												Launch Abort Contingency	
MLA TEL-IV	2	2																								
CIF MIL				2	2	2		2	2	2			2	2		2	2	2	2	2	2	2				
GRI GBM	2	2		1	1	1		1	1	1			1	1		1	1	1	1	1	1	1				
ANT ANG	3			3	3	3		3	3	3			3	3		3	3	3	3	3	3	3				
BDA CVI	2	2		2	2	2		2	2	2	1		2	2		2	2	2	2	2	2	2	3	3		Launch Abort Contingency
ASC ACN	3			3	3	3		3	3	3			3			3	3	3	3	3	3					
PRE TAN	3							3	3											3	3	3				
CRO WOM	3	3		3	3	3		3	3	3			3			3	3	3	3	3	3	3	3	3		
GWM HAW	3			3	3	3		3	3	3			3			3	3	3	3	3	3	3				
CAL GDS	3			3	3	3		3	3	3						3	3	3	3	3	3	3				
GYM WHS	3			3	3	3		3	3	3						3	3	3	3	3	3	3				
TEX GTK				3	3	3		3	3	3			3	1		3	3	3	3	3	3	3				Backup to BDA
LJMA HSK				3	3	3		3	3	3						3	3	3	3	3	3	3				
HSKX KSC				3*		3*																				
MAD MADX				3	3	3		3	3	3						3	3	3	3	3	3					
ARIA RED	3			3	3	3		3	3	3						3	3	3	3	3	3					Reentry Support
VAN MER	2	2		2	2	2		2	2	2			2			2	2	2	2	2	2	2				Insertion Ship Alt. Reentry
HTV	3			3	3			3	3	3										3	3	3				Reentry

LEGEND:  
 1 LAUNCH                      3 ORBIT                      \* - RECEIVE and RECORD ONLY  
 2 LAUNCH AND ORBIT        4 LAUNCH ABORT

### PHOTOGRAPHIC EQUIPMENT

Apollo 7 will carry a 70 mm Hasselblad still camera and two 16 mm Maurer sequence cameras. Film magazines for specific mission photographic objectives are carried for each camera.

The Hasselblad is fitted with an 80 mm f/2.8 standard lens and the Maurer has bayonet-mount 18 mm f/2 and 5 mm wide angle f/2 lenses.

Hasselblad shutter speeds are variable from 1 sec. to 1/500 sec., and sequence camera frame rates of 1, 6, 12 and 24 frames-per-second can be selected.

Film emulsions have been chosen for each specific mission photographic objective. For example, a medium-speed color reversal film will be used for synoptic terrain-weather experiments and rendezvous and spacecraft-LM adapter photography, and a high-speed color film for cabin interior photography. Additionally, a high-resolution low-speed black and white film will be used for some phases of the synoptic terrain-weather photographic experiments.

Camera accessories carried aboard Apollo 7 include window mounting brackets, right-angle mirror attachments, ultraviolet filter, a ringsight common to both camera types, and a spotmeter for determining exposures.

### Onboard Television

A television camera aboard the spacecraft will relay live TV picture from Apollo 7 to the ground.

The 4.5-pound RCA camera is equipped with a 160 degree wide-angle lens and a 9 degree lens. A 12-foot power-video cable permits the camera to be hand-held at the command module rendezvous windows for out-the-window photography as well as mounted in other locations for interior photography.

Mission activities during the first 16 revolutions, such as S-IVB rendezvous, will not permit the crew to operate the camera. After revolution 16, one live TV transmission each day will be possible. Only the Corpus Christi and the Merritt Island Launch Area stations of the Manned Space Flight Network are equipped to receive and convert the spacecraft TV signal.

Among crew activities scheduled for television photography are meal periods, operation on the display keyboards, lithium hydroxide canister changes, Earth scan during photographic experiments and systems test operations.

The onboard system scans at 10 frames a second; ground equipment converts the scan rate to the industry standard 30 frames a second before relaying the picture to Mission Control Center-Houston.

The Corpus Christi and Cape Kennedy ground stations have to use large antennas and extremely sensitive unified S-band receivers to detect the very weak signals from the spacecraft.

In TV broadcast to homes, the average distance is only five miles between the transmitting station and the house receiver, while the station transmits an average of 50,000 watts of power. In contrast, the Apollo 7 spacecraft will be as much as 1,000 miles away from the ground and the power will be only 20 watts.

Because of the greater distance and lower power signals received by the ground antennas will be only 100,000,000th as strong as normally received at private homes. The NASA ground station's large antenna and sensitive receivers make up for most of this difference, but the Apollo pictures are not expected to be as high in quality as normal broadcast programs. The spacecraft TV may be fuzzy and low in contrast, but the home viewer should still be able to see the picture with reasonable clarity.

APOLLO 7 CREW

The crewmen of Apollo 7 have spent more than five hours of formal crew training for each hour of the mission's possible 10-day duration. Almost 1,200 hours of training were in the Apollo 7 crew training syllabus over and above the normal preparations for the mission -- technical briefings and reviews, pilot meetings and study. The Apollo 7 crewmen have virtually lived with their spacecraft in its pre-flight checkouts at the North American Rockwell plant in Downey, Calif., and in pre-launch testing at NASA Kennedy Space Center. Taking part in factory and launch area testing has provided the crew with valuable operational knowledge of this complex vehicle.

Highlights of specialized Apollo 7 crew training topics:

- \* Detailed series of briefings on spacecraft systems, operation and modifications.

- \* Saturn launch vehicle briefings on countdown, range safety, flight dynamics, failure modes and abort conditions. The launch vehicle briefings were updated periodically with a final briefing at T-30 days.

- \* Apollo Guidance and Navigation system briefings and simulations at the Massachusetts Institute of Technology Instrumentation Laboratory.

- \* Briefings and continuous training on mission photographic objectives and use of camera equipment.

- \* Training for the five Apollo 7 experiments. The two photographic experiments will be conducted in flight and the three medical experiments before and after flight.

- \* Extensive pilot participation in reviews of all flight procedures for normal as well as emergency situations.

- \* Stowage reviews and practice in training sessions in the spacecraft, mockups, and Command Module simulators allowed the crewmen to evaluate spacecraft stowage of crew-associated equipment.

- \* More than 160 hours of training per man in Command Module simulators at MSC and KSC, including closed-loop simulations with flight controllers in the Mission Control Center. Other Apollo simulators at various locations were used extensively for specialized crew training.

\* Water egress training conducted in indoor tanks as well as in the Gulf of Mexico, included uprighting from the Stable II position (apex down) to the Stable I position (apex up), egress onto rafts and helicopter pickup.

\* Launch pad egress training from mockups and from the actual spacecraft on the launch pad for possible emergencies such as fire, contaminants and power failures.

\* The training covered use of Apollo spacecraft fire suppression equipment in the cockpit.

\* Planetarium reviews at Morehead Planetarium, Chapel Hill, N. C., and at Griffith Planetarium, Los Angeles, Calif., of the celestial sphere with special emphasis on the 37 navigational stars used by the Apollo Guidance Computer.

Crew Training Summary Table

<u>Activity</u>	<u>Hours</u>
Briefings and Reviews:	
Command-Service Module Systems	140
Launch Vehicle	20
Guidance and navigation program	36
Photography	8
Experiments	8
Procedures:	
Operational Checkout Procedures and Test Checkout Procedures	60
Checklist and Apollo Operations Handbook	50
Emergency and abort	24
Stowage	30
Flight Plan	50
Mission Rules	16
Design and Acceptance	60

Flight Readiness	10
Training reviews	30
Team meetings	60
Pilot meetings	40
Rendezvous	20
Spacecraft test participation:	
Spacecraft cockpit Operational Checkout Procedures and Test Checkout Procedures	80
Simulator training:	
Command Module simulator	160
Command Module Procedures Simulator	60
Dynamic Crew Procedures Simulator	15
Contractor simulators	20
Simulator briefings	75
Special purpose training:	
Stowage	20
Egress	20
Planetarium	20
Spacecraft fire training	5
Intravehicular activity training	<u>9</u>
Total:	1,146

### Apollo 7 Spacesuits

Apollo 7 crewmen, for the first hours of flight, and for the four hours prior to the de-orbit burn, will wear the A7L pressure garment assembly -- a multi-layer spacesuit consisting of a helmet, torso and gloves which can be pressurized independently of the spacecraft.

The spacesuit outer layer is Teflon-coated Beta fabric woven of fiberglass strands with inner layers of aluminized Kapton-coated Beta fabric marquisette spacer for separating insulating layers, a restraint layer, a pressure bladder and an inner high-temperature nylon liner.

Oxygen connections, communications and biomedical data lines attach to fittings on the front of the torso.

A one-piece constant wear garment, similar to "long johns," is worn as an undergarment for the spacesuit and for the in-flight coveralls provided for shirtsleeve operations. The constant wear garment is porous-knit cotton with a waist-to-neck zipper for donning. Attach points for the biomedical harness also are provided.

After doffing the spacesuits, the crew will wear Teflon fabric in-flight coveralls over the constant wear garment. The two-piece coveralls provide warmth in addition to pockets for personal items.

The crewmen will wear communications carriers inside the pressure helmet. The communications carriers provide redundancy in that each has two microphones and two earphones.

A lightweight headset is worn with the inflight coveralls.

### Apollo 7 Crew Meals

The Apollo 7 crew had a wide range of food items from which to select their daily mission space menu. More than 60 items comprise the selection list of freeze-dried bite-size rehydratable foods.

Average daily value of three meals will be 2,500 calories per man.

Unlike Gemini crewmen who prepared their meals with cold water, Apollo crewmen have running water for hot meals and cold drinks.

# APOLLO SPACE SUIT

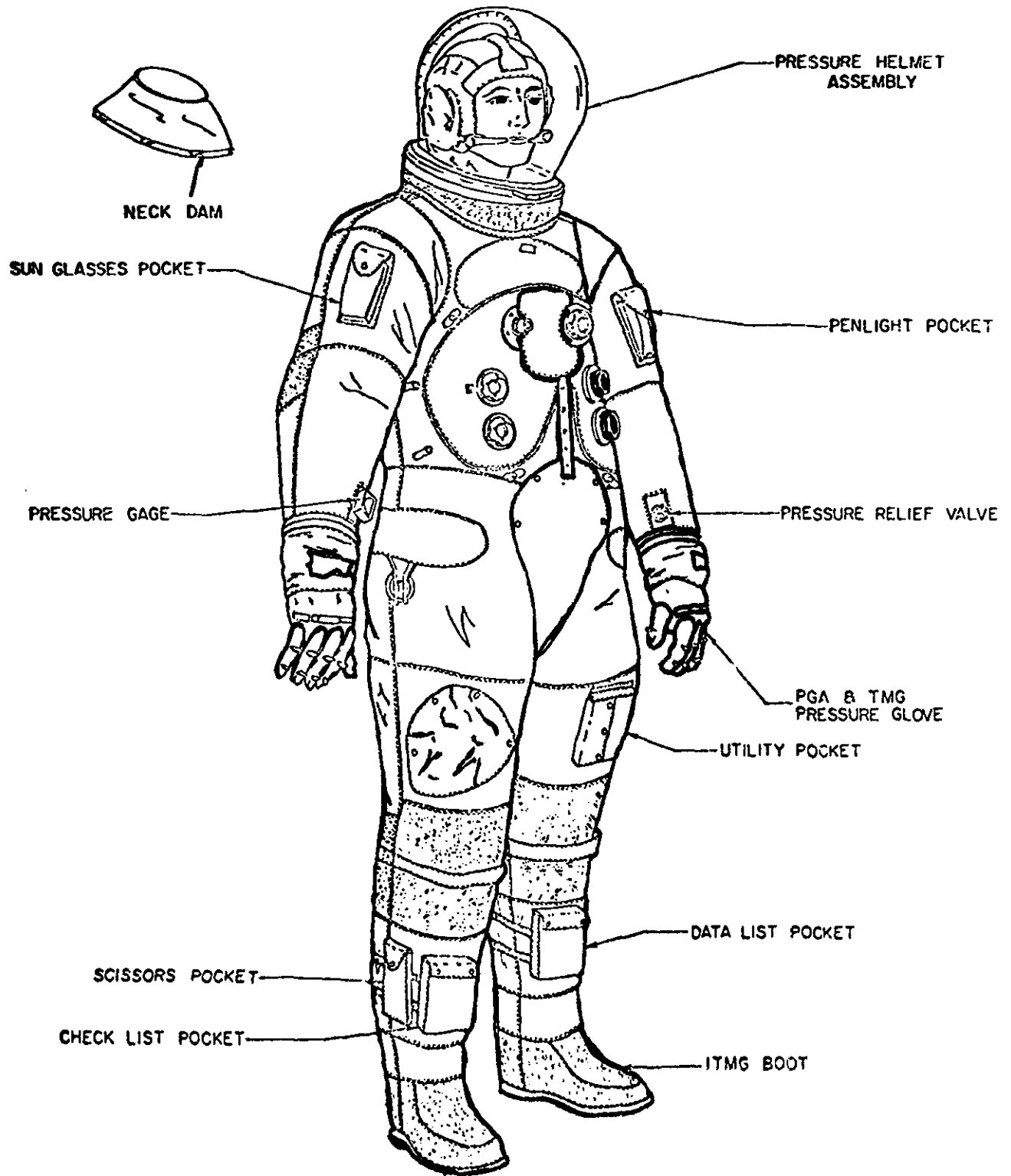



Water is obtained from three sources -- a portable dispenser for drinking water and two water spigots at the food preparation station, one supplying water at about 155 degrees F., the other at about 55 degrees F. The portable water dispenser emits half-ounce spurts with each squeeze and the food preparation spigots dispense water in one-ounce increments.

Spacecraft potable water is supplied from service module fuel cell by-product water.

The menu:

The day-by-day, meal-by-meal Apollo 7 menu for each crewman is listed on the following pages.

Day 1, 5 and 9

Meal A

Peaches (R)  
Bacon Squares (8)  
Cinnamon Toasted Bread  
Cubes (8)  
Breakfast Drink (R)

(Calories 500)

Meal B

Corn Chowder (R)  
Chicken Sandwiches (6)  
Beef Stew Bites (8)  
Sugar Cookies (8)  
Orange Drink (R)  
Breakfast Drink (R)

(Calories 809)

Meal C

Beef and Gravy (R)  
Brownies (8)  
Chocolate Pudding (R)  
Grapefruit Drink (R)

(Calories 917)

Total Calories 2,226

Day 2, 6 and 10

Meal A

Applesauce (R)  
Sausage Patties (R)  
Apricot Cereal Cubes  
(8)  
Breakfast Drink (R)

(Calories 595)

Meal B

Spaghetti w/Meat  
Sauce (R)  
Beef Bites (8)  
Banana Pudding (R)  
Pineapple Fruitcake (6)

(Calories 915)

Meal C

Tuna Salad (R)  
Cinnamon Toasted  
Bread Cubes (8)  
Chocolate Pudding (R)  
Pineapple-Grapefruit  
Drink (R)  
Breakfast Drink (R)

(Calories 895)

Total Calories 2,408

Day 3, 7 and 11

Meal A

Fruit Cocktail (R)  
Bacon Squares (8)  
Cinnamon Toasted  
Bread Cubes (8)  
Cocoa (R)  
Breakfast Drink (R)

(Calories 669)

Meal B

Beef Pot Roast (R)  
Sugar Cookies (8)  
Butterscotch Pudding  
(R)  
Breakfast Drink (R)

(Calories 665)

Meal C

Potato Soup (R)  
Chicken Salad (R)  
Barbecue Beef Bites  
(8)  
Gingerbread (8)  
Grapefruit Drink (R)

(Calories 975)

Total Calories 2,309

Day 4 and 8

Meal A

Canadian Bacon &  
Applesauce (R)  
Strawberry Cereal  
Cubes (8)  
Cinnamon Toasted  
Bread Cubes (8)  
Breakfast Drink (R)

(Calories 611)

Meal B

Pea Soup (R)  
Salmon Salad (R)  
Cheese Sandwiches (6)  
Grapefruit Drink (R)  
Breakfast Drink (R)

(Calories 756)

Meal C

Shrimp Cocktail (R)  
Chicken and Gravy (R)  
Cinnamon Toasted  
Bread Cubes (8)  
Date Fruitcake (6)  
Pineapple-Grapefruit  
Drink (R)

(Calories 965)

Total Calories 2,332

Day 1, 5 and 9

\* Meal A

Peaches (R)  
Corn Flakes (R)  
Bacon Squares (8)  
Toasted Bread Cubes (8)  
Grapefruit Drink (R)  
Breakfast Drink (R)

(Calories 813)

Meal B

Cream of Chicken Soup (R)  
Chicken & Vegetables (R)  
Sugar Cookies (8)  
Chocolate Pudding (R)  
Orange-Grapefruit Drink (R)

(Calories 913)

Meal C

Chicken Salad (R)  
Beef and Gravy (R)  
Date Fruitcake (4)  
Cocoa (R)

(Calories 788)

Total Calories 2,514

\* Meal A, Day 1 omitted on launch day.

Day 2, 6 and 10

Meal A

Applesauce (R)  
Bacon Squares (8)  
Cinnamon Toasted Bread Cubes (8)  
Orange Drink (R)  
Breakfast Drink (R)

(Calories 700)

Meal B

Salmon Salad (R)  
Butterscotch Pudding (R)  
Vanilla Ice Cream (8)  
Grapefruit Drink (R)

(Calories 963)

Meal C

Beef Hash (R)  
Chicken & Gravy (R)  
Cinnamon Toasted Bread Cubes (8)  
Pineapple Fruitcake (4)  
Grapefruit Drink (R)

(Calories 892)

Total Calories 2,555

Day 3, 7 and 11

Meal A

Fruit Cocktail (R)  
Sausage Patties (R)  
Apricot Cereal Cubes (8)  
Cocoa (R)  
Breakfast Drink (R)

(Calories 710)

Meal B

Canadian Bacon and Applesauce (R)  
Beef Pot Roast (R)  
Sugar Cookies (8)  
Butterscotch Pudding (R)  
Cocoa (R)

(Calories 967)

Meal C

Potato Soup (R)  
Beef and Gravy (R)  
Creamed Chicken Bites (8)  
Cinnamon Toasted Bread Cubes (8)  
Pineapple-Grapefruit Drink (R)

(Calories 832)

Total Calories 2,509

Day 4 and 8

Meal A

Canadian Bacon and Applesauce (R)  
Apricot Cereal Cubes (8)  
Pineapple-Grapefruit Drink (R)  
Breakfast Drink (R)

(Calories 660)

Meal B

Pea Soup (R)  
Salmon Salad (R)  
Turkey Bites (8)  
Cheese Sandwiches (6)  
Grapefruit Drink (R)

(Calories 852)

Meal C

Sausage Patties (R)  
Cinnamon Toasted Bread Cubes (8)  
Date Fruitcake (6)  
Grapefruit Drink (R)

(Calories 991)

Total Calories 2,503

-more-

-61-

Day 1, 5 and 9

\* Meal A

Peaches (R)  
Bacon Squares (8)  
Cinnamon Toasted  
Bread Cubes (8)  
Grapefruit Drink (R)

(Calories 696)

Meal B

Cream of Chicken  
Soup (R)  
Chicken Sandwiches (6)  
Beef Sandwiches (8)  
Sugar Cookies (8)  
Chocolate Pudding (R)  
Pineapple-Grapefruit  
Drink (R)

(Calories 1,020)

Meal C

Beef and Gravy (R)  
Beef Stew Bites (8)  
Cinnamon Toast (8)  
Brownies (8)  
Orange-Grapefruit  
Drink (R)

(Calories 788)

Total Calories 2,504

Day 2, 6 and 10

Meal A

Applesauce (R)  
Beef Hash (R)  
Cinnamon Toast (8)  
Apricot Cereal  
Cubes (8)  
Grapefruit Drink (R)

(Calories 786)

Meal B

Tuna Salad (R)  
Beef Sandwiches (8)  
Cinnamon Toast (8)  
Butterscotch Pudding  
(R)  
Pineapple-Grapefruit  
Drink (R)

(Calories 846)

Meal C

Beef & Vegetables (R)  
Barbecued Beef Bites (8)  
Cinnamon Toasted  
Bread Cubes (8)  
Banana Pudding (R)  
Orange Drink (R)

(Calories 897)

Total Calories 2,529

Day 3, 7 and 11

Meal A

Fruit Cocktail (R)  
Bacon Squares (8)  
Cinnamon Toast (8)  
Orange Drink (R)

(Calories 500)

Meal B

Corn Chowder (R)  
Barbecued Beef Bites  
(8)  
Cinnamon Toasted  
Bread Cubes (8)  
Chocolate Pudding (R)  
Orange-Grapefruit  
Drink (R)

(Calories 1,060)

Meal C

Chicken Salad (R)  
Beef Sandwiches (8)  
Cinnamon Toast (8)  
Pineapple Fruitcake (6)  
Orange-Grapefruit  
Drink (R)

(Calories 912)

Total Calories 2,472

Day 4 and 8

Meal A

Canadian Bacon and  
Applesauce (R)  
Cinnamon Toast (8)  
Apricot Cereal  
Cubes (8)  
Pineapple-Grapefruit  
Drink (R)

(Calories 611)

Meal B

Salmon Salad (R)  
Beef Sandwiches (8)  
Cinnamon Toasted  
Bread Cubes (8)  
Gingerbread (8)  
Cocoa (R)

(Calories 1,017)

Meal C

Creamed Chicken Bites  
(8)  
Chicken and Gravy (R)  
Toasted Bread Cubes (8)  
Date Fruitcake (4)  
Orange Drink (R)

(Calories 837)

Total Calories 2,465

-more-

101

\* Meal A, Day 1 omitted on launch day.

### Personal Hygiene

Crew personal hygiene equipment aboard Apollo 7 includes body cleanliness items, the waste management system and a medical kit.

Packaged with the food is a toothbrush and a 2-ounce tube of toothpaste for each crewman. Each man-meal package contains 3.5 by 4-inch wet-wipe cleansing towel. Additionally, three packages of 12 by 12-inch dry towels are stowed beneath the Command Module pilot couch. Each package contains seven towels. Also stowed under the Command Module pilot couch are six tissue dispensers containing 55 3-ply tissues each.

Solid body wastes are collected in Gemini-type plastic defecation bags which contain a germicide to prevent bacteria and gas formation. The bags are sealed after use and stowed in empty food containers for postflight analysis.

Urine collection devices are provided for use either while wearing the pressure suit or in the flight coveralls. Both devices attach to the spacecraft urine dump valve.

A medical accessory kit 6 by 4.5 by 4-inches is stowed on the spacecraft back wall at the feet of the Command Module pilot.

Medical kit contents are three motion sickness injectors, three pain suppression injectors, one 2-oz. bottle first aid ointment, two 1-oz. bottles eye drops, two compress bandages, 12 adhesive bandages and one oral thermometer. Pills contained in the medical kit are 24 antibiotic, 24 nausea, 12 stimulant, 12 pain killer, 24 decongestant, 24 diarrhea and 72 aspirin.

### Sleep-work Cycles

At least one crew member will be awake at all times. The normal cycle will be 16 hours of work followed by eight hours of rest. Simultaneous periods of sleep are scheduled for the command pilot and lunar module pilot.

Sleeping positions in the command module are under the left and right couches, with heads toward the crew hatch. Two lightweight Beta fabric sleeping bags are each supported by two longitudinal straps attaching to lithium hydroxide storage boxes at one end and to the inner structure at the other end.

The bags are 64 inches long and are fitted with torso zipper openings and seven-inch diameter neck openings.

### Survival Gear

The survival kit is stowed in two rucksacks in the right-hand forward equipment bay above the IM pilot.

Contents of rucksack No. 1 are: two combination survival lights, one desalter kit, three pair sunglasses, one radio beacon, one spare radio beacon battery and spacecraft connector cable, one machete in sheath, three water containers and two containers of Sun lotion. Rucksack No. 2: one three-man life raft with CO<sub>2</sub> inflater, one sea anchor, two sea dye markers, three sunbonnets, one mooring lanyard, three manlines and two attach brackets.

The survival kit is designed to provide a 48-hour post-landing (water or land) survival capability for three crewmen between 40 degrees North and South Latitudes.

### Biomedical Inflight Monitoring

The Apollo 7 crew inflight biomedical telemetry data received by the Manned Space Flight Network will be relayed for instantaneous display at Mission Control Center. Heart rate and breathing rate data will be displayed on the flight surgeon's console during spacecraft passes over network stations. Heart rate and respiration rate average, range and deviation are computed and displayed on the digital TV screens. In addition, the instantaneous heart rate, real time and delayed EKG and respiration are recorded on strip charts for each man.

Biomedical data observed by the flight surgeon and his team in the Life Support Systems Staff Support Room will be correlated with spacecraft and spacesuit environmental data displays.

Blood pressure and body temperature are no longer taken as they were in earlier manned flight programs.

Crew Biographies

NAME: Walter M. Schirra, Jr. (Captain, USN)

BIRTHPLACE AND DATE: Mar. 12, 1923, Hackensack, N.J. Parents, Mr. and Mrs. Walter M. Schirra, Sr., reside in Point Loma, Calif.

PHYSICAL DESCRIPTION: Brown hair; brown eyes; height, 5 feet 10 inches; weight: 175 pounds.

EDUCATION: Graduated from Dwight Morrow High School, Englewood, N.J.; B.S., U.S. Naval Academy, 1945; received honorary Doctorate in Astronautical Engineering, Lafayette College, 1966.

MARITAL STATUS: Married to the former Josephine Fraser of Seattle.

CHILDREN: Walter M., III, June 23, 1950; Suzanne, Sept. 29, 1957.

ORGANIZATIONS: Member, Society of Experimental Test Pilots; Fellow, American Astronautical Society.

SPECIAL HONORS: Three Distinguished Flying Crosses, two Air Medals; two NASA Distinguished Service Medals; NASA Exceptional Service Medal; Navy Astronaut Wings; Distinguished Alumnus Award, Newark College of Engineering; Collier Trophy; SETP Kincheloe Award; AIAA Award; American Astronautical Society, Flight Achievement Award; co-recipient of 1966 Harmon Aviation Trophy.

EXPERIENCE: Flight training, Naval Air Station, Pensacola, Fla.

As exchange pilot with U.S. Air Force, 154th Fighter Bomber Squadron, flew 90 combat missions in F-84E's in Korea; took part in development of Sidewinder Missile at the Naval Ordnance Test Station, China Lake, Calif; project pilot for F7U3 Cutlass and instructor pilot for Cutlass and FJ3 Fury; flew F3H-2N Demons in the 124th Fighter Squadron on board the carrier, U.S.S. LEXINGTON in the Pacific.

He attended Naval Air Safety Officer School, University of Southern California and completed test pilot training at Naval Air Test Center, Patuxent River, Md.; later was assigned there in suitability development work on the F4H.

He has accumulated more than 4,300 hours flying time, with 3,300 hours in jets.

**ASSIGNMENTS:** Capt. Schirra was one of the seven Mercury astronauts named by NASA in April 1959.

He piloted the six-orbit "Sigma 7" Mercury flight Oct. 3, 1962--a flight of 9 hours 13 minutes. He attained an altitude of 175 statute miles and traveled 144,000 miles before landing. Sigma 7 was recovered in the Pacific Ocean about 275 miles northeast of Midway Island.

Schirra has since served as backup command pilot for Gemini 3; Dec. 15-16, 1965, was command pilot on Gemini 6. Highlight was successful rendezvous of Gemini 6 with the already orbiting Gemini 7 spacecraft--the first rendezvous of two manned spacecraft. Known as a "text-book" pilot, Schirra remained in the spacecraft following his Mercury and Gemini flights.

-more-



NAME: Donn F. Eisele (Major, USAF)  
NASA Astronaut

BIRTHPLACE AND DATE: June 23, 1930, in Columbus, Ohio

PHYSICAL DESCRIPTION: Brown hair; blue eyes; height: 5 feet  
9 inches; weight: 150 pounds.

EDUCATION: Graduated from West High School, Columbus; B.S.  
degree from the U.S. Naval Academy in 1952 and M.S. in  
Astronautics, 1960, USAF Institute of Technology, Wright-  
Patterson AFB, Ohio.

MARITAL STATUS: Married former Harriet E. Hamilton of  
Gnadenhutten, Ohio; her parents, Mr. and Mrs. Harry  
D. Hamilton, live there.

CHILDREN: Melinda S., July 25, 1954; Donn H., March 24, 1956;  
Jon J., Oct. 21, 1964.

ORGANIZATIONS: Member, Tau Beta Pi, national engineering  
society.

EXPERIENCE: Graduated from the U.S. Naval Academy and  
chose a career in the Air Force, 1952. Graduate of USAF  
Aerospace Research Pilot School, Edwards AFB, Calif.

Project engineer and experimental test pilot at USAF  
Special Weapons Center, Kirtland AFB, N. M.

More than 4,000 hours flying time 3,500 hours in jets.

Maj. Eisele, one of the third group of astronauts selected  
by NASA in October 1963.

**NAME:** Walter Cunningham (civ.)  
NASA Astronaut

**BIRTHPLACE AND DATE:** March 16, 1932, Creston, Iowa; considers Santa Monica, Calif, hometown. Parents, Mr. and Mrs. Walter W. Cunningham, reside in Venice, Calif.

**PHYSICAL DESCRIPTION:** Blond hair; hazel eyes; height: 5 feet 10 inches; weight: 155 pounds.

**EDUCATION:** Graduated from Venice High School, Venice, Calif.; received B.A. with honors in Physics, 1960 and M.A. in Physics, 1961, from UCLA; has completed work, UCLA, on doctorate in Physics with exception of thesis.

**MARITAL STATUS:** Married to former Lo Ella Irby, Norwalk, Calif. Her mother, Mrs. Nellie Marie Maynard, resides in Oxnard, Calif.

**CHILDREN:** Brian, Sept. 12, 1960; Kimberly, Feb. 12, 1963.

**OTHER ACTIVITIES:** Sports enthusiast, particularly interested in gymnastics and handball.

**ORGANIZATIONS:** Member, American Geophysical Union, American Institute of Aeronautics and Astronautics, Sigma Pi Sigma, and Sigma Xi.

**EXPERIENCE:** Joined the Navy in 1951 and began flight training in 1952. Joined a Marine squadron in 1953 and served on active duty until August 1956. Now is Marine reservist, with rank of Major.

Was research scientist for Rand Corp. before joining NASA; worked on classified defense studies and problems of Earth's magnetosphere at Rand.

At UCLA, in conjunction with doctoral thesis problem he developed and tested a search coil magnetometer which was later flown aboard the first NASA Orbiting Geophysical Observatory satellite.

Has 3,500 hours of flying time, more than 2,800 hours in jets.

Cunningham was one of the third group of astronauts selected by NASA in Oct. 1963.

The Crew on Launch Day

Following is a timetable of crew activities just before launch. (all times are shown in hours and minutes before liftoff).

- T-9:00 - Backup crew alerted
- T-8:30 - Backup crew to LC-34 for spacecraft pre-launch checkouts.
- T-4:50 - Flight crew alerted
- T-4:35 - Medical examinations
- T-4:15 - Breakfast
- T-3:45 - Don pressure suits
- T-2:46 - Leave Manned Spacecraft Operations Building for Pad-34 via Crew Transfer Van.
- T-2:30 - Arrive at Pad-34
- T-2:26 - Enter elevator to spacecraft level
- T-2:25 - Begin spacecraft ingress.

-more-

APOLLO 7 TEST PROGRAM

Spacecraft 2TV-1 Manned Thermal Vacuum Test

An eight-day thermal vacuum manned test of an Apollo Command and Service Module similar to the Apollo 7 spacecraft was run last June in the Manned Spacecraft Center's Space Environment Simulation Laboratory, chamber A. All of the test objectives, aimed mostly toward qualifying the spacecraft for manned orbital flight, were met.

The test objectives:

- \*Verify command module heat-shield structure under cold-soak space environment.
- \*Demonstrate capability of electrical power system radiators to handle fuel cell heat transfer needs.
- \*Verify material changes made in the command module.
- \*Verify Earth recovery system compatibility with space environment.
- \*Operate integrated spacecraft systems and subsystems in simulated space environment, both in pressurized and depressurized modes.
- \*Gather thermal data for use in flight vehicle thermal analysis.
- \*Determine environmental control system evaporator water consumption rate in space environment.

Astronaut crew for the test was Joseph P. Kerwin, Vance D. Brand and Joe H. Engle.

Command Module Flammability Testing

Following a series of more than 100 tests in which fires were intentionally set in the cabin of a boilerplate Apollo Command Module, NASA decided to use cabin atmosphere of 60 per cent oxygen and 40 per cent nitrogen on the launch pad.

The tests were run in three phases: 100 per cent oxygen at 6 psi, 100 per cent oxygen at 16 psi, and 60-40 oxygen-nitrogen at 16 psi. While ignition was difficult in the pure oxygen at 16 psi atmosphere, fires had a tendency to spread, and in about half the tests spread beyond acceptable limits without extinguishing themselves.

Fire propagation tests run at 100 per cent oxygen at 6 psi and the 60-40 mix at 16 psi produced acceptable results. The test series showed that the command module interior is adequately protected against the ignition and spread of an accidental fire in the orbital cabin atmosphere of 100 per cent oxygen at 6 psi.

Apollo boilerplate spacecraft 1224, used in the flammability testing, incorporated the materials changes that have been made in the Command Module -- stainless steel instead of aluminum for oxygen lines, protective covers over wiring bundles and replacement of other materials for minimizing flammability.

Representative Command Module materials were ignited in 33 separate tests in the 60-40 16 psi atmosphere and data were gathered on combustion history, temperature, pressure, crew visibility and analyses of gaseous products resulting from combustion.

Test fires were ignited by electrically-heated nichrome wire coils. Placement of igniters was determined by these criteria: proximity to flammable materials such as silicone clamps and spacers; apparent propagation paths such as wire bundles, connectors and terminal boards; large masses of nonmetallic materials; evaluation of earlier fixes of flammability hazards, and proximity to stowage areas containing flammable materials, such as food packets, crew equipment and flight documents.

Igniters were used in most of the tests to assure ignition. The igniters provided a more severe ignition source than would have the overloading of spacecraft wiring.

Results of the flammability tests in the 60-40 oxygen-nitrogen atmosphere at 16 psi showed that the command module is adequately protected against propagation of an accidental fire during prelaunch activities. Some changes were made as a result of the test series, such as removal of acoustic insulation from the spacecraft air circulation duct.

Operationally, the changes in launch pad cabin atmosphere resulting from the flammability test series have required no changes in the spacecraft system which supplies and controls the cabin atmosphere. The crew suit loops will carry 100 per cent oxygen at a pressure slightly higher than cabin pressure to avoid leakage into the suit loop. Some four hours after orbital insertion, the 60-40 oxygen-nitrogen mix will have been gradually replaced by 100 per cent oxygen at 5 psi.

#### Apollo Parachute Development Testing

In the evolution of the Apollo Command Module, the weight has grown from a drawing-board figure of 9,500 pounds five years ago to 12,659 pounds for Apollo 7.

The Command Module's heavier weight made it necessary to modify the drogue and main parachutes in the Apollo Earth landing system.

Initial testing of parachute modifications began in July 1967 with a series of 24 drop tests at the Naval Air Test Facility, El Centro, Calif. Dummy test loads ranging from 5,400 to 13,000 pounds were air-dropped to test opening shock loads on drogue and main parachutes as well as to verify the advantages of additional reefing stages.

A series of drop tests of the all-up Apollo Earth landing system began in April 1968 using a 13,000 pound boilerplate Apollo spacecraft. A total of seven air drops of the complete system, simulating worst-case, abort and normal entry conditions, was conducted. The Earth landing system qualification was successfully completed in July 1968.

Modifications to the Apollo landing system parachutes include increasing the diameter of the drogue chutes from 13.7 feet to 16.5 feet, and employing two-stage reefing in the 83.3-foot diameter main parachutes to provide three phases of inflation -- reefed, partial-reefed and full open -- to lessen opening shock.

## Sea Habitability Tests

Apollo command module post-landing systems underwent an extensive series of tests last spring in an indoor tank at the Manned Spacecraft Center and in a 48-hour manned test in the Gulf of Mexico south of Galveston.

Spacecraft 007A was used for both tests and was similar to Apollo 7 in weight, center-of-gravity and post-landing systems.

The 48-hour sea test, April 5-7, subjected all spacecraft post-landing systems to a sea environment.

Systems and equipment tested and measured for performance were the uprighting system, the post-landing ventilation system, spacecraft recovery aids, (VHF recovery beacon, flashing light, sea dye, grappling hook, survival radio, swimmer interphone) VHF-AM communications, electrical systems and crew comfort and survival equipment.

Spacecraft 007A was hoisted from the deck of MV Retriever into the water apex down in about 18 fathoms, with waves running 3-4 feet and winds of 12-14 knots. Crewmen for the sea test were James A. Lovell, commander, Stuart A. Roosa, Command Module pilot, and Charles M. Duke, Jr., Lunar Module pilot.

The uprighting system rotated the spacecraft from the Stable II (apex down) position to Stable I (apex up) within six minutes after the uprighting bag compressors were turned on. Pressure checks were made on the bags every four hours throughout the test.

The post-landing ventilation system proved adequate and satisfactory for crew comfort. In the daytime the system kept the crew comfortable at low mode while at night it was cycled on every 30 minutes only to purge the cabin of excess carbon dioxide.

The VHF recovery beacon was activated shortly after the test started and was left on for 24 hours. C-119 and HC-130 aircraft made ranging runs at varying altitudes, and acquisition and loss-of-signal ranges were all satisfactory. Similar aircraft ranging runs were made with the spacecraft VHF-AM radio as well as periodic voice checks between the spacecraft and the ship.

Tests with a training-model survival radio in the beacon mode were satisfactory, but the radio was not modulating properly in the voice mode and transmissions were not received by the ranging aircraft. The training radio was substituted since a flight-item radio was unavailable at the time of the sea tests.

When in the beacon mode, the survival radio's signal interfered with the spacecraft VHF-AM reception to the extent that reception of anything else was impossible.

Standby swimmers reported good communications with the crew in four tests of the swimmer interphones during the two-day period.

Aircraft ranging runs were also made on the spacecraft flashing light which was activated for 12 hours each night in the high mode (174 flashes-per-minute) and low mode (20 flashes-per-minute). In the low mode, aircraft pilots acquired the light at 9-10 miles from 10,000 feet, and in both high and low modes, spotted the light at 6-7 miles ranges from 1,200 feet.

Samples of sea water were taken aboard the spacecraft with a hand-held squeeze pump through the steam duct, and desalted. The crew reported the water was drinkable.

The sea dye marker, deployed shortly after the start of the test, emitted a dye slick about 1,000 yards long and 10 yards wide which was easily visible from the air.

Wave heights varied from one to four feet in the two days and wind velocity was recorded at one time to 14 knots. The crew reported no motion sickness or any other ill effects from the test.

Tank testing, May 7-8, ran for 27 hours. The test was aimed primarily at determining whether the post-landing ventilating system could maintain habitable conditions for three crewmen under design limit conditions. Simulated wave motions and day-night environmental cycles (temperature, humidity) were induced throughout the test.

Crew biomedical instrumentation readouts were made on heart and breathing rates. Additional measurements of skin temperatures, cabin interior temperatures and carbon dioxide concentrations were made by the crew.

Other than a heat rash on the leg of one crewman, no ill effects were suffered by the crew. They reported sound sleep in the command module couches and no problems with motion sickness.



### Land Impact Tests

The Apollo spacecraft is designed for landing on water but the possibility that it may land on the ground cannot be ignored.

Instrumented Apollo boilerplate Command Module and airframe spacecraft underwent a series of land-impact tests at the MSC Land and Water Impact Facility to determine accelerations in a beach landing following a possible off-the-pad abort.

Spacecraft pitch altitude and forward velocity were varied in the tests, and vertical velocity for three main chutes deployed (32 fps) and two main chutes (38 fps) onto simulated Cape Kennedy hard-packed beach sand provided data on abort landings. Data were gathered through 108 channels of accelerometers and strain gauges.

Test drops were also made with the spacecraft rolled 180 degrees, a condition that caused the spacecraft to roll over after impact.

Impact damage to spacecraft structure in these conditions was acceptable.

Slight damage was sustained by other equipment in the cabin but in general the tests showed that likelihood of serious crew injury in an off-the-pad abort emergency landing was remote.

### Vibro-Acoustic Testing

The structural integrity of the Apollo spacecraft under launch and boost dynamics were thoroughly tested in late 1967 and early 1968 at the MSC Vibration and Acoustic Test Facility. Vehicle for the vibro-acoustic test series was Apollo spacecraft 105 Command Service Module identical to Apollo 7 from a structural and systems standpoint.

Among the test objectives were qualification of the unified crew hatch tests of wiring and plumbing under launch vibrations, and verification of individual spacecraft components in the vibro-acoustic environment.

Tests were run at low and high frequencies to simulate such conditions as an abort at maximum dynamic pressure (max Q), transonic and max Q normal profiles, and off-limit acoustic stresses.

Low-frequency vibration tests were conducted in the spacecraft longitudinal axis and in one lateral axis at frequencies ranging from 4 to 20 Hz. Acoustic tests simulated random actual-flight vibration conditions.

-more-

MAJOR APOLLO CONTRACTORS

<u>Contractor</u>	<u>Item</u>
Bellcomm Washington, D.C.	Apollo Systems Engineering
The Boeing Co. Washington, D.C.	Technical Integration and Evaluation
General Electric- Apollo Support Department, Daytona Beach, Fla.	Apollo Checkout and Reliability
North American Rockwell Corp. Space Div., Downey, Calif.	Spacecraft Command and Service Modules
Massachusetts Institute of Technology, Cambridge, Mass.	Guidance & Navigation (Technical Management)
General Motors Corp., AC Electronics Div., Milwaukee	Guidance & Navigation (Manufacturing)
Avco Corp., Wilmington, Mass.	Heat Shield Ablative Material

-more-

MAJOR SATURN IB CONTRACTORS

	<u>S-IB Stage</u>
Chrysler Corp. Space Division New Orleans, La.	First Stage
Rocketdyne Division' North American Rockwell Corp. Canoga Park, Calif.	H-1 Engines
Ling-Temco-Vought Dallas, Tex.	S-IB Tanks
Hayes International Corp. Birmingham, Ala.	S-IB Fins
	<u>S-IVB Stage</u>
McDonnell Douglas Corp. Huntington Beach, Calif.	Second Stage
Rocketdyne Division North American Rockwell Corp. Canoga Park, Calif.	J-2 Engines
TRW Inc. Cleveland, Ohio	150-pound thrust attitude control engine
Vickers Detroit, Mich.	Pumps
Bell-Aerosystems, Inc. Buffalo, N. Y.	Fuel and oxidizer tank assemblies for Auxiliary Propulsion System
	<u>Instrument Unit</u>
Federal Systems Division IBM Huntsville, Ala.	Prime Contractor
Bendix Corp. Eclipse Pioneer Division Teterboro, N. J.	St-124M Inertial Platform
Electronic Communication, Inc. St. Petersburg, Fla.	Control Computer
Federal Systems Division IBM Oswego, N.Y.	Digital Computer, Data Adapter

APOLLO PROGRAM OFFICIALS

Dr. George E. Mueller	Associate Administrator for Manned Space Flight, NASA Headquarters
Lt. Gen. Samuel C. Phillips	Director, Apollo Program Office, OMSF, NASA Headquarters
William C. Schneider	Apollo Mission Director, OMSF NASA Headquarters
Chester M. Lee	Assistant Mission Director, OMSF, NASA Headquarters
Col. Thomas H. McMullen	Assistant Mission Director, OMSF, NASA Headquarters
Maj. Gen. John D. Stevenson	Director, Mission Operations, OMSF, NASA Headquarters
Dr. Robert R. Gilruth	Director, Manned Spacecraft Center, Houston
George M. Low	Manager, Apollo Spacecraft Program Office, MSC
Kenneth S. Kleinknecht	Manager, Apollo Spacecraft Office, MSC
Donald K. Slayton	Director, Flight Crew Operations, MSC
Christopher C. Kraft, Jr.	Director, Flight Operations, MSC
Glynn Lunney Eugene F. Kranz Gerald D. Griffin	Apollo 7 Flight Directors, Flight Operations, MSC
Dr. Wernher von Braun	Director, Marshall Space Flight Center, Huntsville, Ala.
Brig. Gen. Edmund F. O'Connor	Director, Industrial Operations, MSFC
William Teir	Manager, Saturn I, IB Program Office, MSFC
W. D. Brown	Manager, Engine Program Office, MSFC

Dr. Kurt H. Debus	Director, John F. Kennedy Space Center, Fla.
Miles Ross	Deputy Director, Center Operation Operations, KSC
Rocco A. Petrone	Director, Launch Operations, KSC
Walter J. Kapryan	Deputy Director, Launch Operations, KSC
Rear Adm. Roderick O. Middleton	Apollo Program Manager, KSC
Paul C. Donnelly	Launch Operations Manager, KSC
Gerald Truszynski	Associate Administrator, Tracking and Data Acquisition, NASA Headquarters
Norman Pozinsky	Director, Network Support Implementation Division, OTDA
Dr. John F. Clark	Director, Goddard Space Flight Center, Greenbelt, Md.
Ozro M. Covington	Assistant Director for Manned Space Flight Tracking, GSFC
Henry F. Thompson	Deputy Assistant Director for Manned Space Flight Support, GSFC
H. William Wood	Chief, Manned Flight Operations Division, GSFC
Tecwyn Roberts	Chief, Manned Flight Engineering Division, GSFC
L. R. Stelter	Chief, NASA Communications Division, GSFC
Maj. Gen. Vincent G. Huston	USAF, DOD Manager of Manned Space Flight Support Operations
Maj. Gen. David M. Jones	USAF, Deputy DOD Manager of Manned Space Flight Support Operations, Commander USAF Eastern Test Range
Rear Adm. P. S. McManus	USN, Commander (combined) Task Force 140 Primary Recovery Area

Rear Adm. F. E. Bakutis

USN, Commander (combined)  
Task Force 130 Pacific  
Recovery Area

Col. Royce G. Olson

USAF, Director, DOD Manned  
Space Flight Office

Brig. Gen. Allison C. Brooks

USAF, Commander Aerospace  
Rescue and Recovery Service

-end-