

Tool Processes in Woodworking

A. P. LAMMELIN

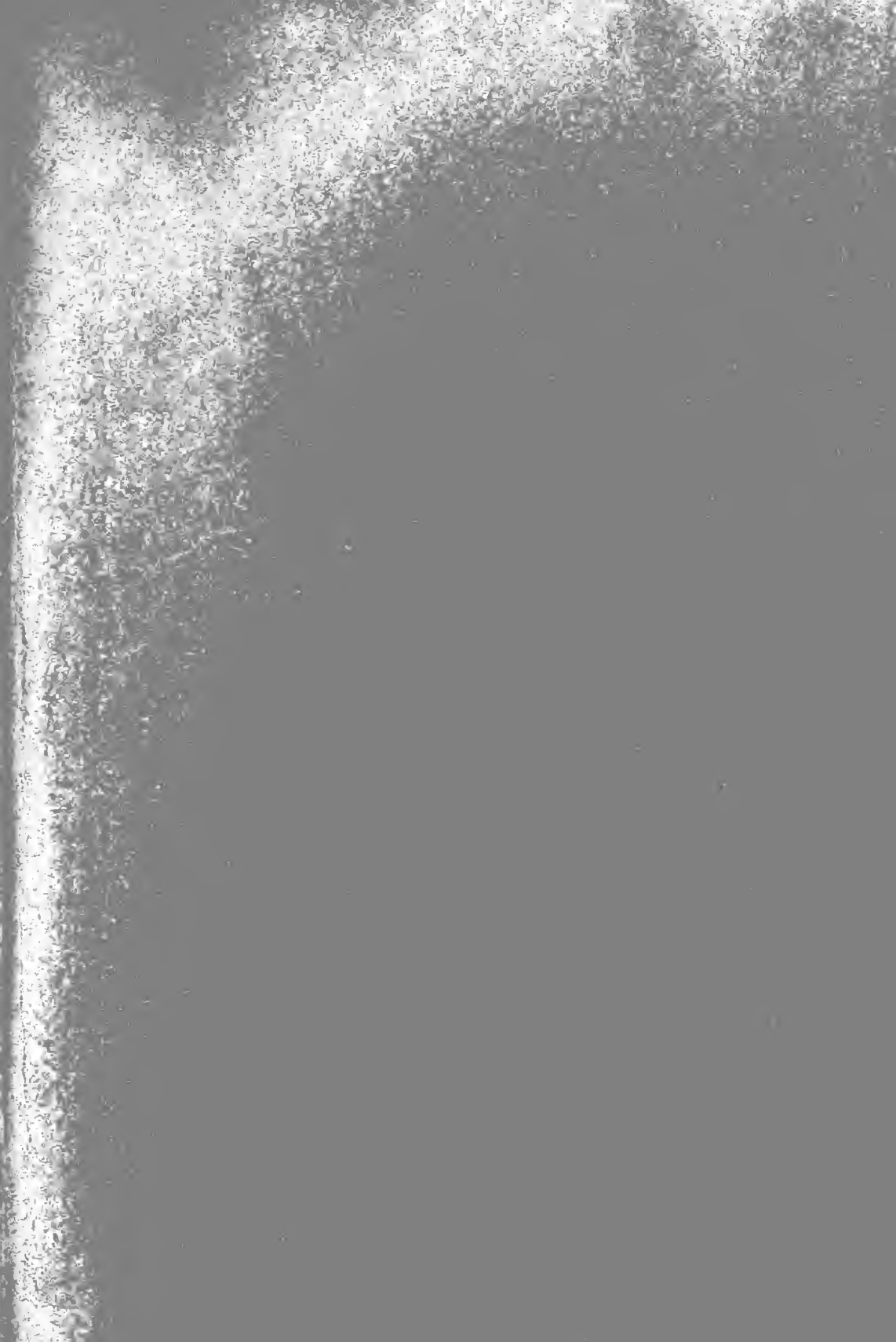



ommerc.
2.

TOOL PROCESSES IN WOODWORKING

By

A. P. LAUGHLIN, A.B., M.S.

Instructor in Industrial Arts, Pullman Free School of Manual Training

Pullman, Illinois



15-5696
22-1/8/20

THE MANUAL ARTS PRESS
PEORIA, ILLINOIS

**COPYRIGHT, 1919, BY
A. P. LAUGHLIN**

INTRODUCTION

This little book is intended to set out only those things that a boy must know in order to do intelligent work with the usual woodworking tools. It is peculiar in what it omits as well as in the way it presents its subject-matter.

It omits everything that the boy can find out easily for himself or that does not contribute to his understanding and skill in the use of tools. Under the head of Reference Work these omissions are suggested as topics for study. Let the students look up these matters as they come to them. A few reference books will do for a large class when used in this way and the boys will come to see the value of books and learn how to use them in their work.

As to form, the book is intended as a text for immature students. Hence, under each topic the operations or principles are set out by number. The teacher may tell the boy to be ready to give a certain number of points about the use, e. g., of the try-square, the marking gage or the sharpening of the plane iron. These points are clearly separated so that the boy can easily distinguish them. If he has not intellectually mastered them he can be left to himself, with the book and a dictionary, until he can, at least, tell the meaning of every word and state the points made by the book. If he does not then understand, the teacher must somehow show and explain. "Man is the imitative animal par excellence" and we must not neglect this fact in our scheme of teaching. However, there are some things that the boy must know and this little text is intended to point out these things (and these only), hinting at more and endeavoring to stimulate an appetite for more.

The book is especially helpful with boys who have been absent, and again with the boys who are inattentive.

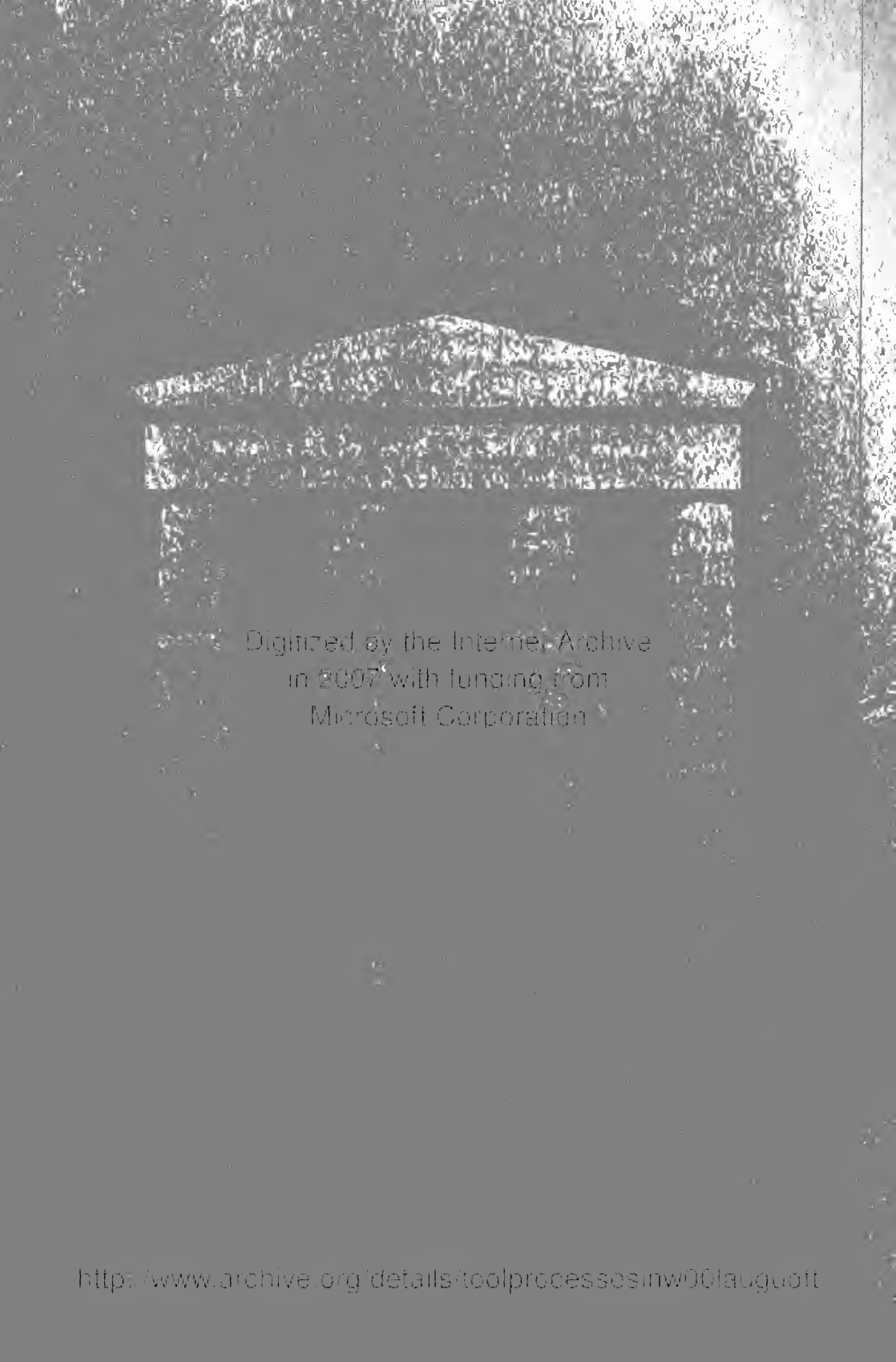

Digitized by the Internet Archive
in 2007 with funding from
Microsoft Corporation

CONTENTS

CHAPTER I

METHOD OF PROCEDURE.....	7
How to proceed when making a model.	
Pointers. Reference work.	

CHAPTER II

DRAWING	9
Assembly and detail drawings. The bill of materials. Pointers.	
How to lay out the plate. Conventions. Dimensioning a plate.	
Standard letters and figures. Relationship of views. Conventional lines. The title. Reference and experimental work.	

CHAPTER III

MEASURING AND LAYING-OUT TOOLS.....	20
The two most important principles. How to use the rule, the try-square, the marking gage, the T-bevel, the steel square, the dividers. Reference and experimental work.	

CHAPTER IV

HAND SAWS	25
Use of the crosscut and rip saws. How to set and sharpen saws. Reference work.	

CHAPTER V

PLANES	28
Adjustments. Shape of cutting edge. Use of smooth, jack, jointer and block planes. Surface, edge, and end planing Pointers. Reference and experimental work.	

CHAPTER VI

GRINDING AND SHARPENING TOOLS.....	34
Grinding, whetting, reference, and experimental work.	

CHAPTER VII

SQUARING STOCK TO DIMENSIONS.....	37
The method and pointers. Reference work.	

CHAPTER VIII

MISCELLANEOUS TOOL PROCESSES.....39
Making duplicate parts. Form work. Use of the scraper. Use of sand paper. Nailing. Fastening with screws. Use of hand screws. Glue. Reference work.

CHAPTER IX

THE COMMON JOINTS.....52
The dado. The glue joint. The mortise-and-tenon. Reference work.

CHAPTER X

WOOD FINISHING60
The complete processes of staining, filling, and finishing. Fuming. Oil finishing. Reference work. Care of brushes. The stain bench. Reference work.

CHAPTER XI

LUMBERING67

CHAPTER XII

SUGGESTIONS TO TEACHERS.....69
Method. Reference and experimental work. Shop Organization. How to keep up interest in drill work. Manual Training Equipment.

CHAPTER I

METHOD OF PROCEDURE

When starting any model or project in the shop proceed as follows:

1. Make a drawing or set of drawings that will show the size and shape of every piece that enters into its construction, and the method of assembling the parts. (See Chapter II.)
2. Make out a bill of materials from the drawings. (See Chapter II.)
3. Select and cut the stock for the entire project and mark each piece so that you will always know what it is to be used for.
4. Square all pieces to dimensions, remembering to work duplicate parts together. (See Chapters VII and VIII.)
5. Lay out all joints, cuts, and holes on each of the pieces, remembering to measure always from the face side, the joint edge, and the end first squared. (See Chapter IX.)
6. Show to the teacher and receive his O. K.
7. Try out on a practice piece any joint or unit of construction that is new to you or that you have failed to handle satisfactorily on preceding models.
8. Show this practice work to your teacher and receive his permission to proceed with the construction of the model in hand.
9. Cut the parts to their proper outline, cut the joints, bore the holes, and fit the parts together, following the methods as outlined in Chapters IV, V, VII, VIII, and IX.
10. Scrape and sand the surfaces. (See Chapter VIII.)

11. Stain, fill, and finish the parts. (See Chapter X.)

At times some, or all of the parts should be assembled and glued before the staining and finishing is done. Judgment must be used at this point. Glue will not, of course, stick well to finished surfaces. On the other hand, the parts can be finished and polished much better and more easily before they are assembled than afterward.

12. Assemble and fasten the parts.**Pointers:**

1. Remember that dull tools never do good work.
2. Use tools for the purpose intended. The try-square should be used to test right angles and to serve as a guide in laying out work. It is not intended to be used as a hammer or a screw driver. Again, use a mallet to force the chisel to its work. The hammer is intended for driving nails.

Reference Work: Study the methods of work of several successful men in your town and classify the qualities that have made them succeed. Does any man who is careless and inattentive, and always asking help of others, ever get to be a foreman or a superintendent? Has travel or reading helped make these men successful? Are they systematic? Who are the men who are willing to accept responsibility and to "deliver the goods?" Are they the successful men or the failures? Would it hurt you to spend a few minutes daily in inspecting the stain table, the tool case, or the lumber rack, reporting the conditions you find to your teacher, and putting things in order for him? The habits you will form, if you keep a note book and do such work systematically and faithfully, will doubtless be as valuable to you as any tool practice that you will ever get. You will have started your career as a foreman and superintendent. Read, *Control of Mind and Body* and *Mind and Work*, by Luther H. Gulick,

CHAPTER II

DRAWING

Before you can make any project you must know the size and shape of every part that enters into its construction. You must also know how the parts are assembled. Properly made working drawings will show all this. Hence, when making a new model, it is wise to proceed as follows:

NAME	GRADE	BENCH No
FOOT STOOL	SCALE	DATE

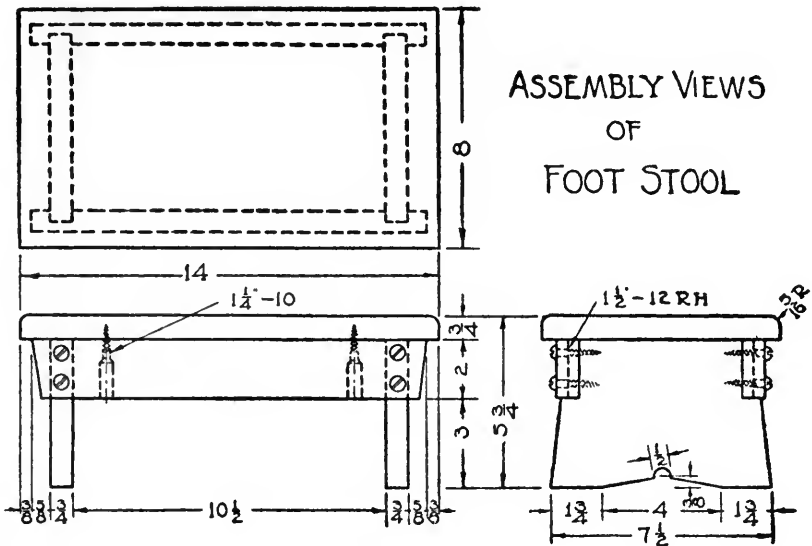
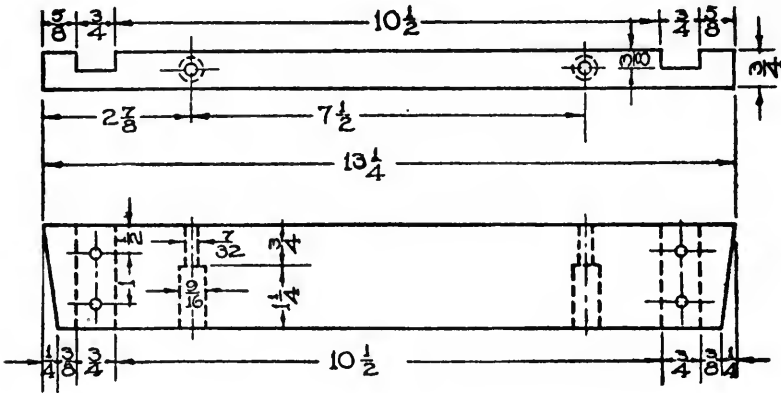

Fig. 1.

1. If drawings are not furnished, make one or more that will show the size and shape of every part, and the method of assembling it in the finished article. (See Figs. 1 and 2.)

The assembly drawing (Fig. 1) should be made first. It may, or may not, show all the dimensions needed to construct the article. Its purpose is rather to show the general proportions of the parts

DETAIL PARTS OF FOOT STOOL



SIDE RAILS

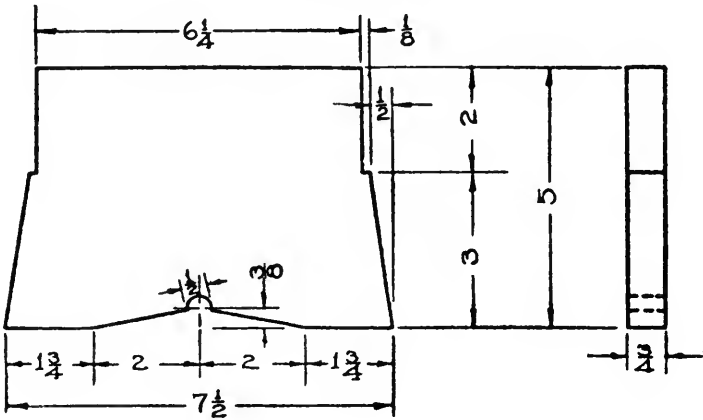

LEGS

Fig. 2.

and how they are arranged and fastened. It should, however, be drawn to scale and give as many dimensions as possible without crowding.

2. If drawings are furnished, detail each of the parts to be made, i. e., draw them out full size, or to a large scale, and note all the dimensions necessary to make them. (See Fig. 2.)

BILL OF MATERIAL	
Name <i>John Frye</i>	Bench No. <i>9</i>
Teacher <i>W. C. Jones</i>	Started <i>Jan, 14</i>
Project <i>Table Stool</i>	Finished <i>Mar, 3</i>
Material <i>Str. Oak</i>	
<i>1 piece for top 7/8 x 8 x 14</i>	
<i>2 pieces for legs 7/8 x 7 1/2 x 5</i>	
<i>2 pieces for rails 7/8 x 2 x 13 1/4</i>	
<i>Approximately 1 3/4 bd. ft.</i>	
<i>8 - 1 1/2" #12 R. H. Screws</i>	
<i>4 - 1 1/4" #10 F. H. Screws</i>	
Total Cost <i>30 cents</i>	

Fig. 3.

We do this to make sure that we really understand the drawing furnished us, for it is quite possible to make a beautiful copy from a drawing without understanding it at all. If, however, we make

detailed drawings of the parts from the assembly used, we must, of necessity, read the drawing.

3. From the assembly used make out a bill of materials (Fig. 3).

We should never neglect this matter of making out a bill of materials for it again compels us to read our drawing.

Pointers:

- 1. A working drawing should give all the dimensions needed to construct the article.**
- 2. Keep your pencils sharp.**

Uncover about $\frac{1}{4}$ " of the lead with the knife, but sharpen the lead on a piece of sand paper or a file.

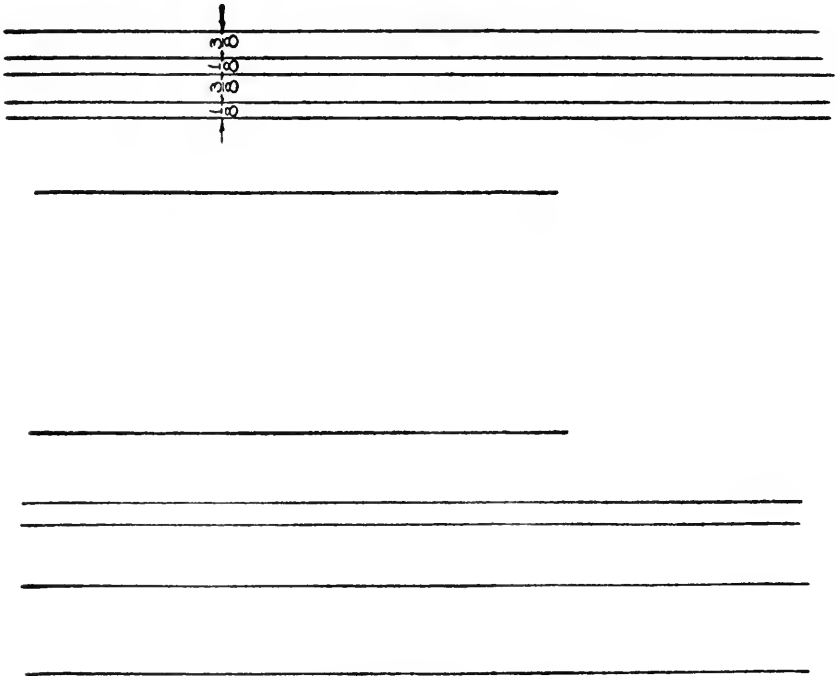

Fig. 4.

- 3. The T-square is used as a guide in drawing horizontal lines.**

Note: In all this work, the head of the T-square should be held

firmly against the left hand end of the drawing board. If you are left handed, you will, of course, use the right hand end of the board.

4. The triangles are used in combination with the T-square to draw:
- (a) Vertical lines.
 - (b) Angles of 45, 60, 30, 15, and 75 degrees with the horizontal.

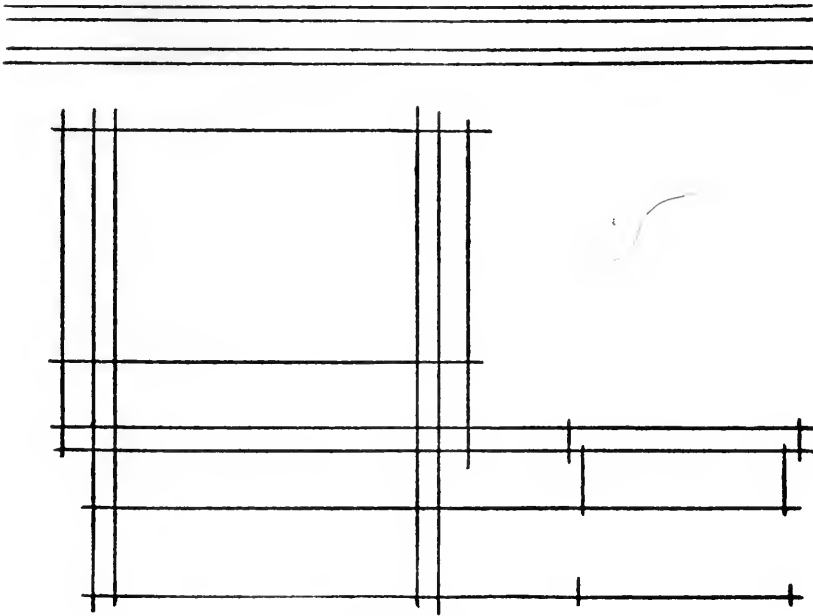

Fig. 5.

5. Lay out a plate by means of long, light, indefinite lines.
- (See Figs. 4, 5, 6, 7 and 1.) As shown by these figures, the steps to be taken are as follows:
- (1) Locate and draw lightly and of indefinite length the main horizontal lines. (See Fig. 4.)
 - (2) Locate and draw the main vertical lines. These lines should also be light and of indefinite length. (See Fig. 5.)

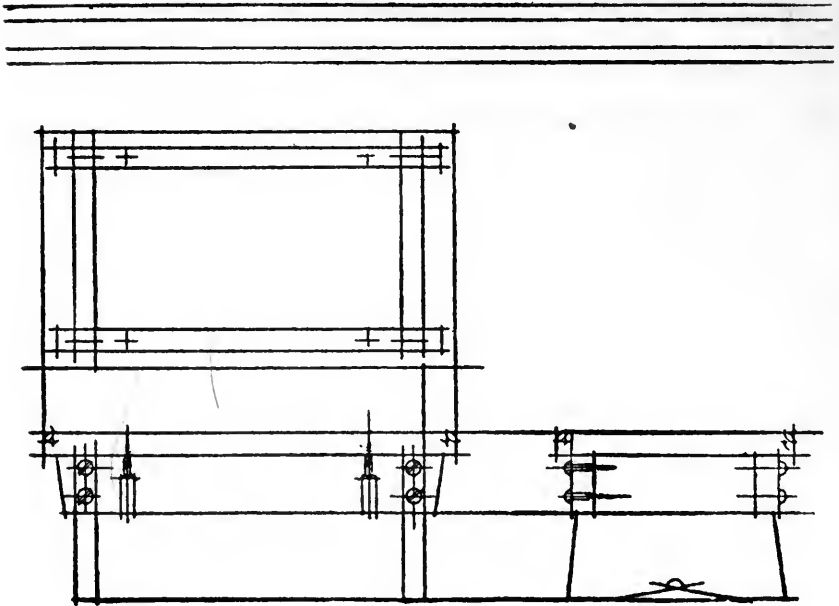

Fig. 6.

NAME

GRADE

BENCH No.

FOOT STOOL

SCALE

DATE

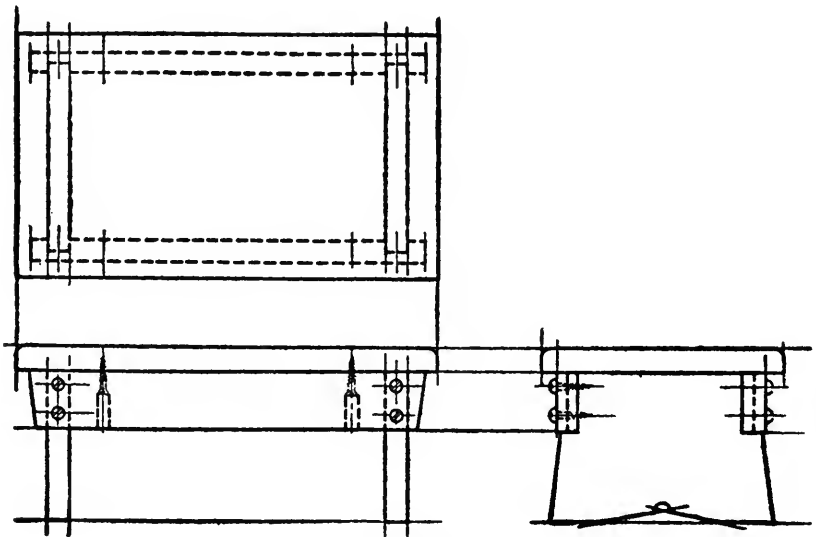

Fig. 7.

- (3) Block in all the diagonal lines, arcs of circles and other details. (See Fig. 6.)
- (4) Go over the outlines of the figure with a heavy line. Circles and arcs of circles should be drawn over first. (See Fig. 7.)
- (5) Dimension and letter the plate. (See Fig. 1.) Note the title strip used. The spacing of the guide lines for the lettering is shown in Fig. 4. Fig. 8 shows a Perspective or picture view of the finished stool.

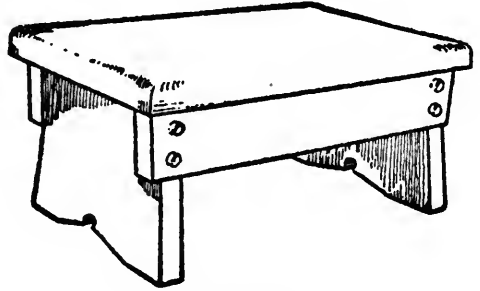

Fig. 8.

6. Study the conventions used in dimensioning drawings as shown in Fig. 9. Study also Fig. 1 and Fig. 2, and note:
- (1) That the arrow points are placed at the limits of the space being dimensioned.

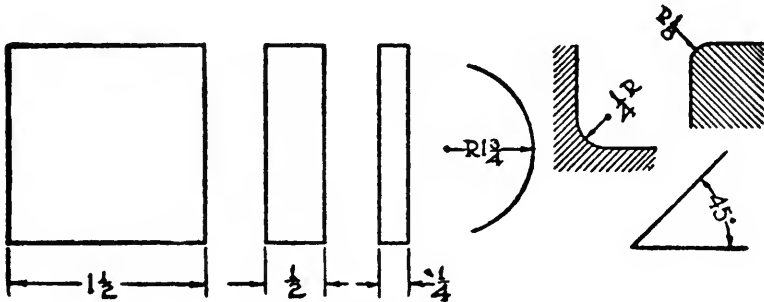

Fig. 9.

- (2) That in dimensioning a series of spaces the dimensions are, if possible, placed in one line and summed up just outside that line. (Fig. 2.)

- (3) That the dimensions should not be crowded
 - (4) That a dimension is never placed upon a center line or a line of the object:
 - (5) That dimensions are kept off the figure as much as possible.
7. A scale drawing is one in which all the parts are drawn proportionately larger or smaller than the object.
 8. The scale of a drawing should always be stated.
 9. The dimensions placed upon a drawing always indicate the finished size of the object no matter what scale is used.

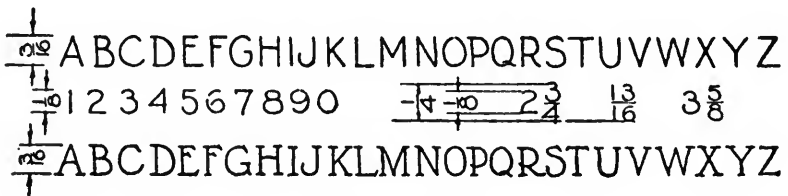

Fig. 10.

10. Letters and figures must be carefully made, if the plate is to look well.
 - (1) Equal height, equal slant and even spacing are the first essentials in good lettering.
 - (2) Standard capitals are $\frac{3}{16}$ " high. The first alphabet (Fig. 10) illustrates a simple Gothic vertical alphabet. After this has been mastered the second example of the same alphabet, with serifs added, may be used.
 - (3) Standard figures are $\frac{1}{8}$ " high with fractions double height.
11. The usual method of placing views is shown in Fig. 1. The plan view is placed above and is what one would

see if he were above the above object and looked down.

The end view shows the object as it would appear if one were looking at it from the position that it occupies on the plate.

Two views will often show all that one needs to know about an object in order to construct it.

12. Note the conventional lines shown in Fig. 11.

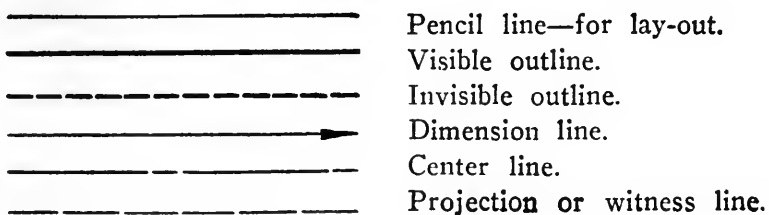

Fig. 11.

13. The title of the drawing should tell:

- (1) The name of the article.
- (2) The scale of the drawing.
- (3) Who made the drawing.
- (4) The date it was made.
- (5) Any other items, e. g., the number of the student's bench, the name of the school, etc., that may be of service to the user of the drawing.

Do not be afraid of putting too much into the title of a drawing, or of putting too many notes on a plate.

Why?

14. A good working drawing is one that tells everything necessary to construct the article.

All letters and figures must be legible.

All lines clear, sharp, and not confusing.

15. Look up the following topics:

- (1) "Sections." Find out when and why section views are used. What are "revolved" sections? Define "cross-hatching."
- (2) Use of architect's scale.
- (3) Making of tracings.
- (4) Making of blueprints.

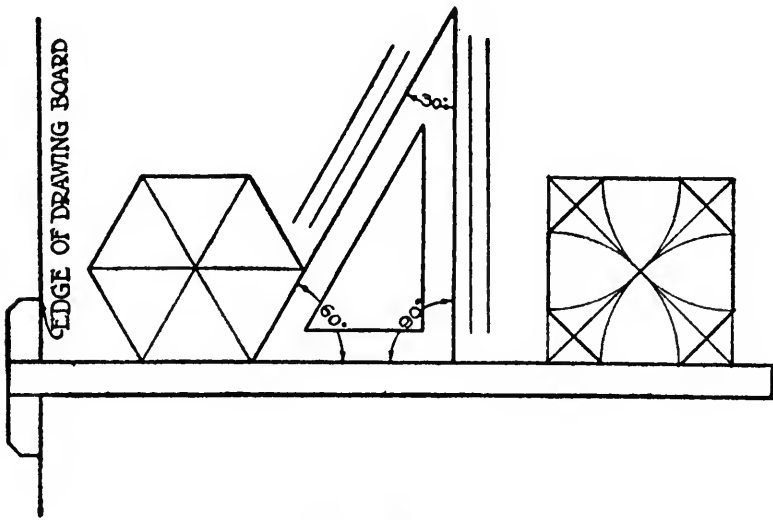

Fig. 12.

- (5) Find out how to construct a regular hexagon.
 - (a) When one side is given;
 - (b) When the distance across the points is given;
 - (c) When the distance across the flats is given;Learn the draftsman's method (see Fig. 12); the method of "Euclidian" geometry; the method of the carpenter who uses his steel square. Ask some good mechanic to help you.

- (6) Find how to construct a regular octagon when the problem presents itself in each of the ways mentioned in the case of the hexagon.

Note the solution given in Fig. 12.

How many other solutions can you find?

- (7) Draw a triangle (Fig. 13) with sides in the ratio of 3, 4, and 5 and note that one of the angles is a right angle. Why?

Ask the mason or the carpenter when and where he uses this theorem.

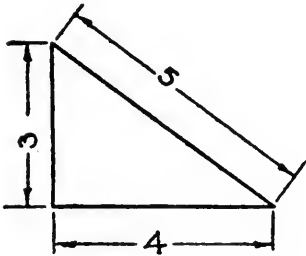

Fig. 13.

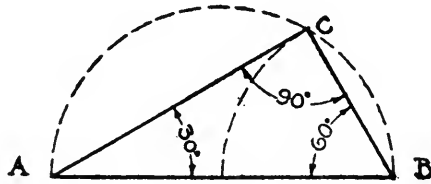

Fig. 14.

- (8) To construct a triangle with angles of 30° , 60° and 90° .

(a) Draw a semicircle.

(b) With center at B, and a radius equal to the radius of the circle, describe an arc cutting the semicircle at C.

(c) Draw the lines AC, CB, and AB.

The resulting triangle has angles of 30° , 60° , and 90° as shown in Fig. 14. Why?

- (9) Find how to bisect a line; an angle.

Ask some good mechanic what other geometrical problems he finds most useful.

CHAPTER III

MEASURING AND LAYING-OUT TOOLS

It is impossible to over-emphasize the value of properly "laying out" one's work. If his lines are wrong, the workman stands a poor chance of cutting things to fit.

The two most important rules to remember in laying out all work may be stated briefly as follows:

1. **Measure, gage, and square all spaces and all lines from fixed starting points or surfaces.**

The working face, the joint edge, and the end first squared are always used for these purposes by mechanics. Why? See Rules for squaring stock to dimensions, Chapter VII.

2. **Knife lines and gage lines should be used when one wishes to do accurate work.**

These lines can be felt as well as seen. Properly made, they represent the first cut as well as the lay-out of the job. There are some exceptions to this rule, e. g. bevels and chamfers should be laid out with pencil lines. Why?

The Rule—How to Use

1. **In pointing off a number of spaces along a line, measure them all from one starting point.**

For example, do not measure part of them from one end of a board and part from the other. The piece may be too long or too short.

2. **In pointing off accurate measurements, a knife or needle point should be used.**

The knife point is used in the shop and the needle point in the drafting room. For rough work a pencil point will often do.

3. **All thick edge rules, e. g., the carpenter's pocket rule (See Fig. 15), should be turned upon edge when used**

in measuring, so that the lines will run down to the work.

Some rules, e. g. the architect's scale, have thin edges to accomplish this same purpose.

4. Always measure in the direction intended, not at an angle to it.

For example, in measuring the length of a board, apply the rule to a long edge of the board or along a line parallel to it.

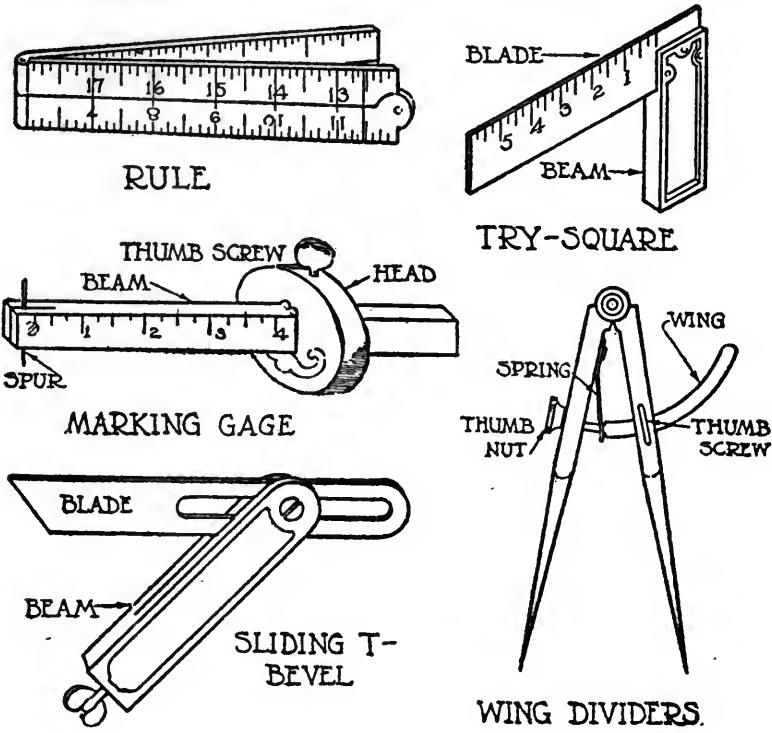

Fig. 15.

5. In pointing off short spaces (i. e., those within the limits of the rule) do not move the rule, for with every setting of the rule errors may occur.

The Try-Square—How to Use

1. The try-square is composed of a beam and a blade set at right angles to each other. (See Fig. 15.)

2. It is used, (a) to test right angles, and (b) as a guide for the knife or pencil in drawing lines at right angles to a surface, usually across the grain of wood.
3. In laying out work or testing angles, always keep the beam against either the face side or the joint edge of the work.

For an explanation of the terms, "face side" and "joint edge," see Rules for squaring stock to dimensions, Chapter VII.

4. In laying out work with a try-square and knife the lines should be run so that they will not show upon the finished surfaces.

The blade is graduated (See Fig. 15) so that lines can be started and stopped at any desired distances. *Therefore, draw the cross lines first and the gage lines afterward in laying out mortises, tenons, gains, etc.*

Notes:

- (1) The blade of the try-square can be, and often is used as a straight-edge or as a rule. These are, however, accidental and not fundamental uses. There are other tools for these purposes.
- (2) One large try-square is very useful and should be found in every well equipped shop.

The Marking Gage—How to Use

1. The marking gage is composed of a beam, a head, a spur, and a thumb screw. (See Fig. 15.)
2. The marking gage is used to make lines parallel to an edge, usually in the direction of the grain of the wood.
3. When using, always keep the head of the gage against the "face side," or the "joint edge" of your work. (See Rules for squaring stock to dimensions, Chapter VII.)
4. For accurate work test the setting of the gage with the rule.

The spur may be bent or sharpened so that the distance from the point to the head is more or less than the reading on the beam.

5. When using the gage roll the beam over so that the spur will drag.
6. Do not attempt to gage a line on a board without pressing the end of the board firmly against something rigid.
7. Avoid running gage lines so that they will show upon the finished work. (See Rule 4, The Try-Square—How to use.)
8. In laying out chamfers and all cuts not at right angles to the surface, a pencil gage should be used. Why?
9. In gaging for joints always use very light lines and set the gage exact.

There are times, however, when one should set the gage "strong" and run a heavy gage line, e. g. when gaging for width. The saw can then be made to cut to the center of the gage line and one or two strokes with the plane will bring the piece to exact width and just remove the gage line. (See notes on sawing, Chapter IV.)

10. The gage is an edge tool. The spur must, therefore, be kept sharp.

Reference Work: It will be interesting to look up the slitting gage, the pencil gage, the mortise gage, the butt gage, the panel, the surface and bit gages. Any tool catalog will show all of these, and it will not be difficult to learn their uses.

The T-Bevel

1. The T-Bevel is composed of a beam and an adjustable blade. (See Fig. 15.)
2. It is used to lay out and test angles other than right angles.

Reference Work: Learn how to set the T-bevel for 45° , and for 30° and 60° , using the steel square as a guide.

Hints:

- (1) The angle that the diagonal of a square makes with its sides is an angle of 45° .

- (2) Look up Fig. 14, Chapter II, and see if you can apply the figure so as to use the steel square to set for a 30° angle.

Note that in this figure the hypotenuse is the diameter of the circle, while one side of the triangle is equal to one-half the diameter of the circle, and that one angle is 90° , the angle of the steel square. If you fail to see it, ask some good mechanic to show you the trick.

The Steel or Framing Square

The steel square may be of any size. It is used in the manual training shop largely to test angles, and in setting the T-bevel. The carpenter finds many other uses for it. It is especially useful to him in laying out rafters and stair stringers. Let the class send to any manufacturer of framing squares and ask for a book of instructions on how to use them.

The Dividers

The dividers, or compasses, are constructed in various ways, but the so-called wing dividers are found in most shops. (See Fig. 15.) They are used:

1. To lay out circles or arcs of circles.
2. To space off equal distances.
3. To scribe lines parallel to an irregular edge or surface.

Reference Work: Look up:

Trammels, calipers, level, plumb-bob, use of chalk line.

Topics for home study: Look up and try to construct apparatus to measure (a) temperature, (b) time, (c) steam pressure, (d) quantity of liquids, (e) density of liquids. Try to make a balance to weigh (1) ounces accurately, (2) pounds accurately, (a) up to 10 lbs., (b) up to 200 lbs.

CHAPTER IV

HAND SAWS

1. **Crosscut and rip saws.** Woodworkers use two types of saws, one to cut across the grain, the other to cut lengthwise of the grain of wood. They are called, respectively, crosscut and rip saws.
2. **The saw kerf.** The opening that either saw makes (due to its thickness and the set of the teeth) in passing thru a board is called its kerf.
Since this kerf has width it must always be considered and an allowance made when getting out material or cutting joints. Can you get two six-inch pieces out of one twelve inches long? Why?

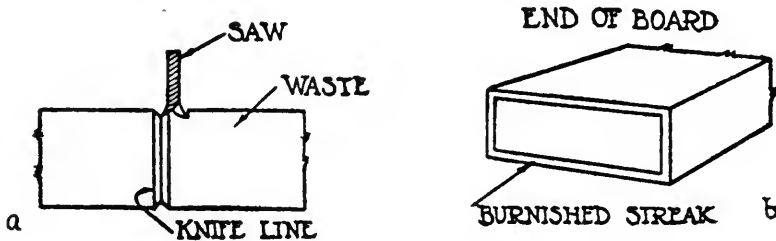

Fig. 16.

3. **Always keep the kerf in the waste stock.**
You should always try to saw to the center of the knife or gage line. (See (a) Fig. 16.) If you do the work accurately, you can see the burnished streak left by the knife or gage line after the sawing is complete. (See (b) Fig 16.)
4. **The teeth of the crosscut saw are filed to a point.** (See Fig. 17.)
These points are arranged to come alternately, first over one side of the blade and then over the other. This is done to cause the

teeth to cut the fiber of the wood first at the limits of the kerf, just as the spur of the auger bit first cuts a circle on the wood before the lip removes any shavings; and for the same reason, namely, to prevent tearing the grain of the wood. After the points of the teeth have severed the fiber of the wood, the backs of the teeth crumble and carry out the wood of the kerf in the form of sawdust.

5. The rip saw has teeth filed to a cutting edge. (See Fig. 17.) They are formed like chisels and cut in the same way.

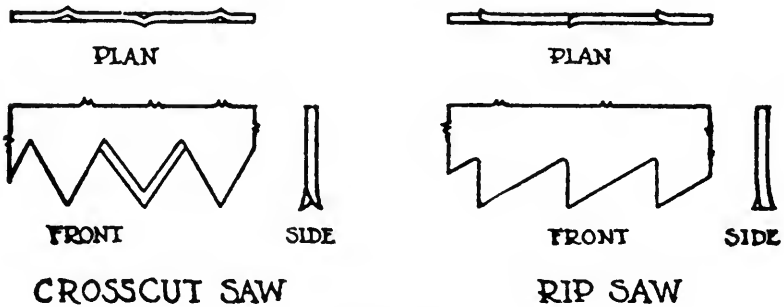

Fig. 17.

6. A dull saw, either crosscut or rip, is put into condition by:

- (1) *Jointing the teeth*, i. e. running a file over the teeth lengthwise of the saw to bring them all to the same length.
- (2) *Setting the teeth*, i. e. bending just the very points of the teeth alternately to the right and to the left. This is done to prevent the saw binding in the kerf. A saw requires more set to work well in soft, wet wood than in hard, dry wood. Why?
- (3) *Filing the teeth to correct shape.*

Important: Wherever accurate sawing is required all lines should be run with the knife or marking gage. Either tool, when sharp, opens somewhat the fiber of the wood, forming a V-shaped groove with burnished sides. After sawing, these burnished surfaces should show. (See (b) Fig. 16.)

Reference Work: Look up and report upon the following:

Compass, keyhole, bow-turning and coping saws. Also the back saw and the miter box. Make a collection of pictures taken from trade catalogs showing as many varieties of saws as possible. Write to Henry Diston & Sons, Philadelphia, and ask for their *Hand Book on Saws*. It describes the manufacture and explains the use and care of both saws and files. It is free to schools and teachers.

CHAPTER V

PLANES

Fig. 18 shows the type of plane that is commonly used to smooth and true the broad surfaces, edges, and ends of boards.

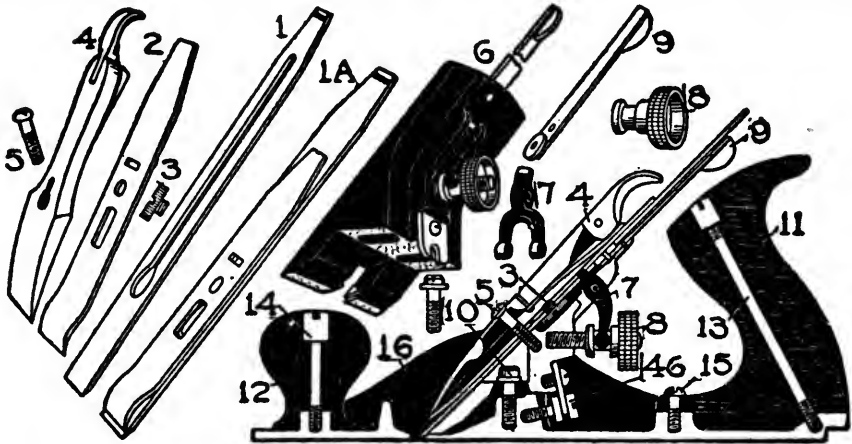

Fig. 18.

1A, double plane iron; 1, single plane iron; 2, plane iron cap; 3, cap screw; 4, lever cap; 5, lever cap screw; 6, frog complete; 7, "Y" adjusting lever; 8, adjusting nut; 9, lateral adjusting lever; 10, frog screw; 11, plane handle; 12, plane knob; 13, handle bolt and nut; 14, knob bolt and nut; 15, plane handle screw; 16, plane bottom; 46, frog adjusting screw.

Adjustments

This plane has four principal adjustments:

1. The thickness of shaving taken is regulated by turning the adjusting nut (No. 8, Fig. 18). The direction to turn this nut can only be learned by trial for planes differ in this respect.

2. The plane is made to take shavings of equal thickness at both edges by means of the lateral adjusting lever (No. 9).
3. The cap or breaker iron (No. 2) can be moved back from, or down close to, the cutting edge of the plane iron (No. 1) according as one wishes to take thick or thin shavings.

The purpose of this cap iron is to break over the shavings, thus preventing the splitting action that would occur in front of the blade whenever the grain happened to run down into the wood. When the surface is very cross-grained or curly, this splitting action cannot be entirely prevented. It can, however, be reduced to a minimum by moving this breaker iron down to within $1/64''$ or less of the cutting edge and then taking very thin shavings.

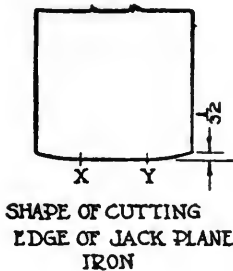

Fig. 19.

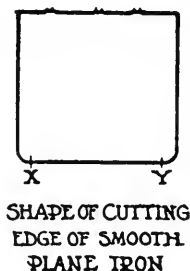

Fig. 20.

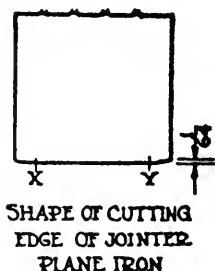

Fig. 21.

4. On the best planes the mouth opening may be reduced by moving the frog (No. 6) forward.

This should be done only when the grain is very troublesome and very thin shavings must be taken.

Shape of the Cutting Edge

Figures 19, 20, and 21 show the shapes of the cutting edges of the three principal planes.

In each of the above the iron should be straight, or very nearly so, from X to Y.

USES OF PLANES

Surface Planing

The jack plane is about 14" long and is used to "rough out" the work. Its cutting edge (Fig. 19) is made slightly "crowning," hence it will take a shaving that is thicker in the center than at the edges. In use, run the center of the plane over the high spots, holding the sole firmly on the work.

Note: By sharpening the cutting edge about as one would sharpen the cutting edge of the jointer plane, by setting the cap iron close to this edge, and by taking thin shavings, this plane can be made to do the work of the smooth plane and the jointer.

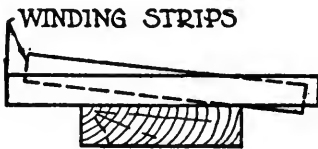

BOARD IN WIND

Fig. 22.

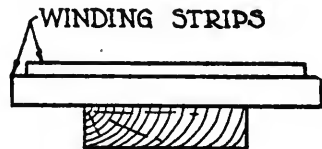

BOARD OUT OF WIND

Fig. 23.

The smooth plane, which is about 8" long, is used to follow the jack plane upon the broad surfaces. Its cutting edge should be kept very sharp and nearly straight (See Fig. 20) with only the corners slightly rounded back. The cap iron should be adjusted very close to the cutting edge and the mouth opening kept small.

The first broad surface planed is called the "working face" (or face side) and is always given a "witness mark" by which it may be distinguished. This working face should be made not only a smooth surface, but also a true plane, i. e., free from warp and wind. It can be tested (a) by laying it upon a true surface, (b) by means of a straight edge held not only lengthwise and

crosswise, but diagonally as well, (c) by means of "winding strips." These are strips with parallel edges that are laid across the board near its ends. By sighting across from one "strip" to the other it is easy to tell when their top edges are in the same plane and hence whether or not there is any wind in the board.

In figure 22 the winding strips show that the surface is in "wind."

In figure 23 they show that the surface is not in wind.

Edge Planing

1. **The jack plane or the jointer should be used in edge planing.**

Both of these planes have their blades sharpened slightly crowning. (Figs. 19 and 21.)

The jointer, which is about 24" long, should be used when making glue joints or edges that must be very straight. It may be used to do the whole job, or it may be kept extra sharp and finely adjusted and used only to take the last few shavings.

2. **See that each plane is adjusted so that the center of the blade projects slightly while the edges are still even with or slightly above the sole of the plane.**
3. **Test the edge of the board with the try-square, holding the beam against the working face and the blade across the edge. (See Fig. 24.)**
4. **With the center of the plane over the high side, take a shaving, keeping the sole of the plane firmly pressed against the edge of the board.**

Fig. 25 shows what takes place. Since the center of the plane iron projects farther than the edges, the shaving taken is thicker on one edge than the other, and each shaving taken with the plane held in this position brings the edge nearer square with the face than before. A few such shavings will bring the edge of the board square with its working face.

5. The first edge planed is called the joint edge. It is always given a witness mark by which it may be distinguished.

End Planing

If you plane straight across the end of a board you are sure to splinter the farther corner. Hence you must either :

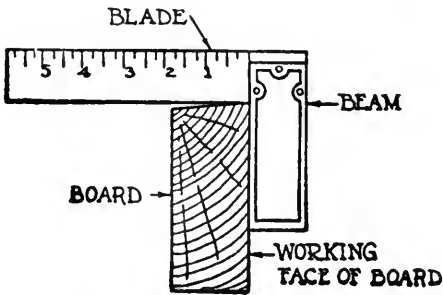

Fig. 24.

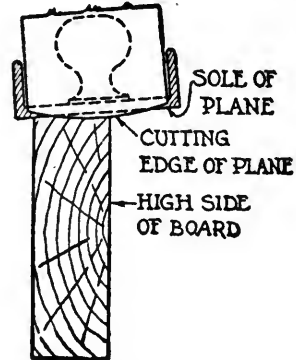

Fig. 25.

1. Plane from both edges toward the center, stopping in both cases before the far edge is reached, or
2. Put a stick behind the far edge to support the fiber of the wood.

If the board is wide enough, the farther corner may be chamfered off to prevent splintering in planing. This method is not, however, approved by most mechanics. Why?

Unless the end of the board is to show, no planing should be required. The saw should finish the job.

Note: Where one must hold his work with one hand while planing the end, a block plane (Fig. 26) is needed, otherwise the jack or smooth plane may be used.

Pointers:

1. The plane iron cap must always be put on the flat side of the plane iron.
2. The plane iron cap must be screwed tight or it will slip.

3. In assembling the plane, be sure that the plane iron is down in place before turning down the lever clamp. If it has to be forced, something is wrong.
4. For fast work on soft, straight grained wood set the plane iron cap back and make the mouth opening ample.

What to do when the grain is troublesome:

1. See that the cutting edge is very sharp.
2. Set the plane iron cap close to the cutting edge.
3. Make the mouth opening as narrow as possible.
4. Take thin shavings.

Reference Work:

1. The block plane (Fig. 26) has no cap iron. Why?
2. Collect and mount pictures of as many varieties of planes as possible, and learn the use of each.
3. Look up especially the rabbet plane.

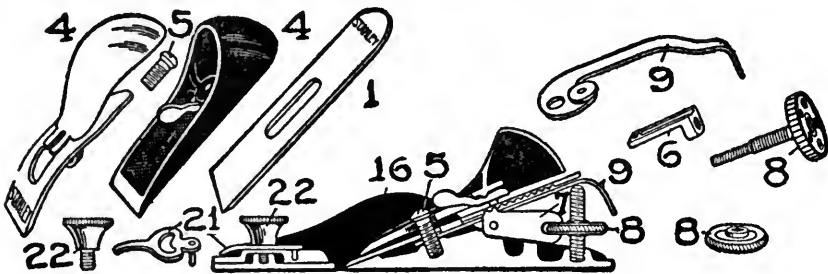

Fig. 26.

1, single plane iron; 4, lever cap; 5, lever cap screw; 6, frog complete; 7, adjusting lever; 8, adjusting nut; 9, lateral adjusting lever; 16, plane bottom; 21, eccentric plate; 22, finger rest knob.

Experimental Work: Take three shavings from the edge of a $\frac{7}{8}$ " soft pine board 30" long, one to be of even thickness on each edge; one to be thicker on the right edge; and one to be thicker on the left.

Do this by sharpening the plane iron crowning, and holding the center of the plane, first, over the center of the piece, second, over the right edge and third, over the left edge.

CHAPTER VI

GRINDING AND SHARPENING TOOLS

Grinding is the first operation in sharpening such bevel edge tools as plane irons and chisels. The more important points to remember are:

1. **Grind plane irons and chisels to an angle of about 22°.**

That is about the right angle for general use. If one is working altogether in hard wood the angle may be made a little greater, while for soft wood, it could be made somewhat less.

2. **Grind the edge of both plane irons and chisels perfectly straight and square across.**

Whatever crown is desired on the plane iron is given while whetting on the oilstone.

3. **In grinding keep the stone wet.**

A dry stone glazes quickly and will soon heat the tool so as to draw its temper. If the edge turns blue the temper has been drawn, and one must then grind below the blued part before the tool will hold its edge.

While the stone should be kept wet when in use, it should not stand in water. Why?

A dry emery or carborundum wheel can be used to grind tools, but in this case the tool should be dipped in water occasionally and great care exercised not to "burn" the steel.

Notes: If the stone is kept round and true a block of wood can be fastened to the back of the grindstone frame (See Fig. 27) and the grinding done, both rapidly and well, by pressing the plane iron down between the block and the stone. It is not difficult to true a grindstone with a piece of gas pipe and if it is kept true, the labor involved is not great.

Whetting. The grindstone or tool grinder does not put a proper cutting edge on a plane iron or any edge tool. This is done with the oilstone. The method is as follows:

1. See that the surface of the stone is well oiled with a good grade of machine oil.

The oil prevents glazing of the stone. Be careful to use machine oil, as any drying oil such as linseed oil, will ruin the stone. Why? If, thru mistake, this should happen, the stone can be burned out, but great care must be exercised in introducing and withdrawing the stone from the fire to avoid cracking.

After using, the stone should be wiped dry.

Note: There is a great advantage gained by mounting an oil-stone loosely in an iron box with an oil saturated felt pad under the stone, for, by simply turning the stone over, a well oiled surface is presented. Otherwise, one must always have a filled oil can at hand.

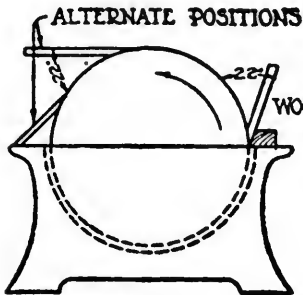

Fig. 27.

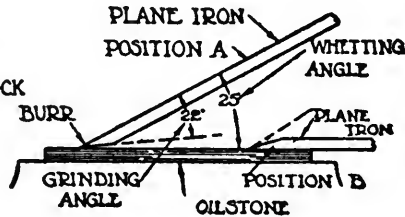

Fig. 28.

2. In the case of plane irons and chisels, whet on the beveled side until a slight "burr" can be felt on the flat side. (See position A, Fig. 28.)

The whetting angle should be slightly greater than the grinding angle as shown in position A, Fig. 28.

3. Turn the tool over and whet one or two strokes on the flat side.

Be sure that the plane iron or chisel is flat down upon the stone, as shown in position B, Fig. 28. Why?

4. Whet first on one side and then on the other until all the wire edge or burr is removed, being sure always to hold the tool flat upon the flat side.

5. **A block of wood, a piece of leather, or the hand should be used to remove the last traces of the wire edge.**
6. **The cutting edge of the chisel should be kept straight and square across from side to side. In the case of the plane iron the proper amount of "crown" or curvature can be given by pressing harder first on one end of the cutting edge and then on the other.**
7. **The whetting surface of the oilstone should be kept true and smooth, otherwise it is difficult to sharpen tools properly.**

If holes are worn into the stone they may be removed by grinding the stone down on a piece of emery cloth tacked upon a flat surface.

Remember that the chisel and the plane iron are beveled on one side only. This means that, in whetting, they must be held flat down upon the stone on the flat side.

Reference and Experimental Work:

1. By means of a strong reading glass study the condition of the cutting edge of your plane from the first grinding until the last trace of the wire edge is removed.
2. Devise a set of experiments to test the difference between linseed oil and machine oil. Suppose the labels were lost, could you tell one from the other?
3. Collect the raw material and try to make and refine (a) a good grade of linseed oil, (b) a good grade of machine oil.
4. How are grindstones and oilstones made? Write to the Pike Mfg. Co., Pike, N. H., and to the Carborundum Co., Niagara Falls, N. Y., for literature.

CHAPTER VII

SQUARING STOCK TO DIMENSIONS

The best mechanics observe the following order in planing a board to dimensions:

1. **Plane a "working face" and mark with a "face" or "witness" mark.**

A working face should be a true plane surface, i. e. smooth, out of wind, and not warped. See winding strips, scraping, and sanding.

It is a fundamental principle among mechanics that, since mistakes are always likely to occur, all measurements, all gaged lines, and all squared lines in any particular direction, or upon any particular surface, are to be made from one starting place. This, then, is the reason for establishing the working faces and for following the order of steps as are here stated. The witness marks are placed on these faces so that they can always be distinguished.

2. **Plane a "joint edge" and put on a witness mark.**

A joint edge should be straight from end to end and square with the face side. Test for squareness with the try-square. Sight down the edge or use a straight-edge to test for straightness.

3. **Gage and plane to width.**

4. **Gage and plane to thickness.** This step may often be omitted. (See notes on judgment, following.)

5. **Square one end.** (See sawing and end planing, Chapters IV and V.)

6. **Measure for length, measuring from the end just squared.**

7. **Square lines about the board at the required length, using knife and try-square.**

8. **Saw to the center of the knife line, keeping the saw kerf in the waste stock.**

Test for squareness both from the working face and the joint edge. If the knife line was properly made and the saw handled skillfully the end of the piece will show a burnished streak all about the cut. (See (b) Fig. 16.)

9. Give the end a planed finish.

Judgment in using the rules. The boy, as the mechanic, should always follow the above order of procedure. If he omits any step, it should be because the project he is making does not require him to perform that step, e. g., if the end of a piece does not show, it need not be given a planed finish. Again, if the thickness is unimportant, it is not necessary that it be planed to exact dimensions. In a word, then, one should understand the complete method of planing to dimensions, but he would not be expected to perform unnecessary operations simply for the sake of following a rule. Judgment when and when not to follow a rule, as well as skill, distinguishes the true mechanic.

Pointers:

1. Do not forget to put witness marks on your working face or your joint edge. Why?
2. The joint edge must be not only square with the working face; it must also be straight, otherwise lines squared from it will not be parallel.
3. The ends must be square with both the face side and the joint edge.
4. Do not be afraid to use your try-square and your rule.

Reference Work: The matter of squaring stock to dimensions is of such fundamental importance that we would urge you to:

1. Ask, say, ten good mechanics whether or not they follow the rules for planing as stated above. If not, find out their reasons for changing the order.
2. Look up this matter in ten text books (or as many as you can find). If the order is changed, find out the reason.

CHAPTER VIII

MISCELLANEOUS TOOL PROCESSES

Duplicate Parts

It is very important to note when parts are duplicates or "pairs," and to work them together, for time is thus saved and mistakes avoided. Hence, in making duplicate parts proceed as follows:

1. Plane a face side on each piece in turn.
2. Plane a joint edge on each piece in turn.
3. Gage each of the pieces for width with one setting of the gage.
4. Plane each piece in turn to width.
5. Gage each of the pieces to thickness with one setting of the gage.
6. Plane each piece in turn to thickness.
7. Square one end of each piece in turn.
8. Assemble all the pieces with their joint edges up and their squared ends together.
9. Measure all distances to cuts, mortises, holes, etc., from the squared end and along the joint edge of one of the pieces. Then transfer these measurements to the other pieces by means of the try-square.
10. Separate the parts, finish the lay-out and the cutting of each piece in turn.

Notes:

- (a) Sometimes parts are duplicates only in certain particulars, e. g., thickness, length, or locations for mortises, holes, etc. In such cases proceed as above, making the necessary omissions.
- (b) Sometimes it is better to get out a number of small parts all in one piece and then cut the piece into the proper lengths.

Reference Work: Ask a carpenter how he lays out the "plates" for a house. Ask him to show you other places where he has to deal with pairs and duplicate parts.

Use of the Chisel

1. **The cutting edge of the chisel is made straight and square.**
Otherwise it is ground and sharpened like a plane iron.
Caution: Keep the flat side flat.
2. **Always use a mallet rather than a hammer to drive the chisel. Why?**
3. **Always take thin shavings when cutting to, or close to, a line.**

If thick shavings are taken lengthwise of the grain, the wood will split and follow the direction of the grain. If thick shavings are taken across the grain, the wedging action causes the chisel to spread the cut in both directions and so to crowd over the line intended.

4. **If possible give the chisel a sliding or shearing motion when cutting across the end grain of wood.**
Examine the cutting edge of your chisel with a reading glass and you will discover the reason.
5. **In cutting "thru" mortises, dadoes, etc., work from both surfaces toward the center of the piece. Why?**

Reference Work: Look up and report the meaning of the terms: tang chisel, socket chisel, firmer chisel, framing chisel and bevel-edge chisel. Make sketches and describe the special advantages and uses of each.

Form Work

Table and chair legs, hall trees, the sides of magazine racks, writing desks, etc., are often so designed as to leave no edges parallel with their vertical axes. It often happens, however, that mortises or screw holes must be located at right angles to the vertical axis. While it is possible to lay out such work from a vertical axis, or by other special means, it is usually better:

1. To establish a face side and a joint edge.
2. To lay out all mortises, cuts, or screw holes, and as much of the outline as possible from these two surfaces before cutting them away.

Cutting to Curved Outlines

A narrow bladed saw such as the compass or the turning saw is the proper tool to use in cutting to an irregular or curved outline. It is always possible, however, to work out such pieces with a common saw, a knife, and a chisel.

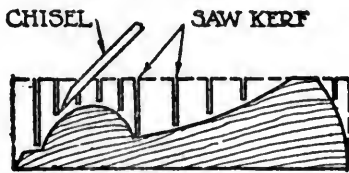

Fig. 29.

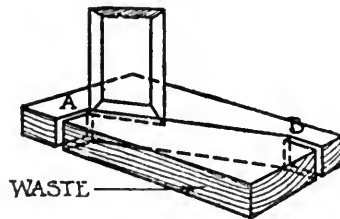

Fig. 30.

Fig. 29 shows how this should be done. One must always observe the grain of the wood, and cut in the direction of the fiber, not against it. A half-round 12" bastard file is often the best tool with which to finish such cuts.

In paring to the line A B (Fig. 30), start the chisel in at the end A and proceed toward B. Why not begin at B? (Note the direction of the grain of the wood.) The work should be laid out on both sides so that the chiseling may be done from both surfaces toward the center. It is also best to clamp your work on top of a cutting board so that you can use both hands in guiding and forcing the chisel to its work.

Use of Scraper

There are cross-grained or curly places on nearly all pieces of wood that will tear somewhat under the plane no matter how skillfully it may be used. Such places must be made smooth before the stain and other finish is applied. Sand paper may be used to do this on soft woods, but on hard wood the scraper is the proper tool to use. For flat surfaces most cabinet makers sharpen their scrapers square across as shown at A (Fig. 31), but make the edge slightly crowning from end to end, as shown at B (Fig. 31).

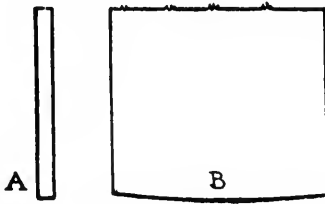

Fig. 31.

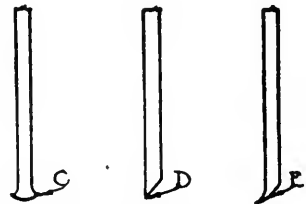

Fig. 32.

The sharpening may be done either with a grindstone or with a file, followed by the oilstone. After the edges have been made perfectly sharp they should be turned with a burnisher (a hard, smooth piece of steel) so that they look somewhat as shown at C (Fig. 32). This is done by passing the burnisher, with considerable pressure, lengthwise over the edge of the scraper, tilting it slightly as the work proceeds.

In use, the scraper is held at an angle of about 60° with the surface of the work. If it is sharp and the edge properly turned it will cut like a plane. Inexperienced persons are often tempted to try to make the scraper do the work of the plane. This is a mistake for if much material is removed the surface will become very uneven due to the fact that the scraper tends to cut more on the soft than on the hard spots. To counteract this tendency, the scraping should be done so

that the strokes of the scraper will cross one another at an angle.

Some mechanics prefer to sharpen their scrapers as shown at D (Fig. 32) and to turn the edge as shown at E. A scraper sharpened in this way will take a very heavy shaving and should, therefore, be held in some sort of a handle or frame.

Use of Sand Paper

1. **Never use sand paper until all the work with the edge tools is finished. Why?**
2. **Always sand lengthwise of the grain, otherwise you will make cross-scratches on your work.**
3. **On flat surfaces the sand paper should be held on a block.**
The block helps to overcome the tendency of the paper to cut more on the soft than on the hard spots. On irregular shapes special blocks or the fingers must be used.
4. **Never attempt to fit joints by using sand paper or a file.**

Reference Work:

1. Find out how sand paper is made. How it is graded.
2. Look up the manufacture of files, how they are graded, and when and how they should be used.

Nailing

For careful nailing observe the following:

1. **A line should be run to locate the centers of the nails.**
It is best to run this line on both sides and on both edges of the board. And, since the surfaces are usually "cleaned," i. e., planed and sand papered, before the nailing is done, these center lines should be very light pencil lines rather than knife or gage lines.
2. **Start the nails on the center lines.**
It will then be easy to tell whether or not they will go into the second piece without coming thru on one side or the other. In

Fig. 33, nail A would enter piece X properly, while nail B would surely pass out the side. If any nails are started wrong they should be drawn out and started again.

3. **Clamp or hold pieces in position, i. e., so that the center lines for the nails will coincide.**
4. **Drive the nails nearly all the way in, but leave them so that the claw of the hammer can easily draw them out if necessary.**

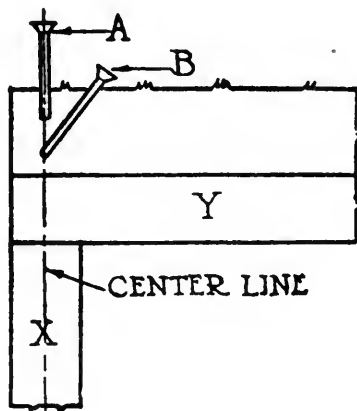

Fig. 33.

5. **Inspect the work, and, if the pieces are in their proper positions and no nails show a tendency to come thru anywhere, drive the nails in and set them.**

Nails hold best if they are driven at a slant for they then act like dovetails. It is always possible to slant nails in two directions without their coming thru the sides of the second piece.

Important: Use a brad-awl for small nails and a small bit for larger ones whenever a nail would be likely to split the wood. A little paraffine, or even soap, will be of great help in driving nails into hard wood. The soap will rust the nails, however, while the paraffine will not.

Reference Work:

1. Look up blind or splinter nailing, toe-nailing, clinching.
2. How does the carpenter hold his hammer for heavy nailing?
3. Collect, mount, and label all the different nails that you can find. (The hardware man will very likely help you.) Here are a few that you should find: single and double-pointed tacks of various sizes and weights, rivets, dogs, finish, and common nails, brads, cut nails, copper and galvanized nails, furniture nails and tacks.
4. Do the same for screws.

It would be interesting to trace the making of a nail from the ore thru the blast furnace, the Bessemer converter, the rolling mills and the reheating and wire drawing processes to the stamping mills. Thence thru the packing and shipping departments to the freight depot, to your own town, to your own merchant, and to yourself. If you wish to make this study, if you wish to learn something of this great world of industry, something of the men who have developed it, something of the priceless inheritance that they have given you, let me recommend that you read *Inventors at Work*, by Geo. H. Iles, and also his *Flame Electricity and the Camera*.

Fastening with Screws

1. Carefully locate the centers for the screw holes in the piece A (Fig. 34) thru which the screws are to pass.
2. Bore "body size" holes in piece A equal to or a little larger than the diameter of the screws just under the head.
3. Clamp the pieces in position—it is well to use center lines to determine the proper locations—and mark the centers in piece B.

4. Bore core size holes in piece B equal to the diameter of the screws at the root of the thread.
5. Countersink the body size hole if a flat head screw is to be used.

Notes:

- (a) As with nails, paraffine or soap may be used as a lubricant on the threads of screws.
- (b) If you do not wish the head of the screw to show, you may bore a hole large enough to receive the head of the screw and then plug the hole. The plug cutter is a handy tool to use in this connection.

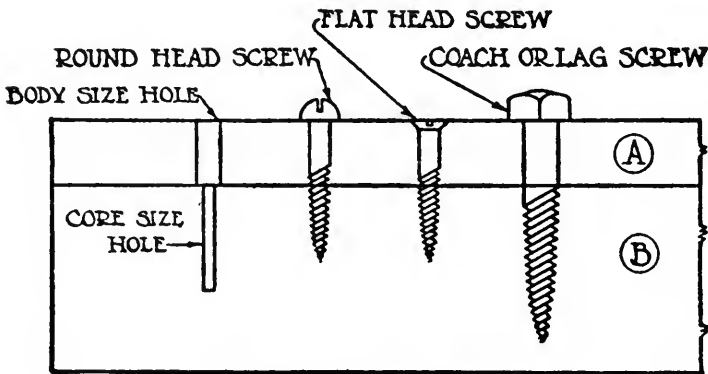

Fig. 34.

Reference and Experimental Work: Look up "drive screws." Experiment as to the holding power of screws in end grain and cross grain of wood. Collect and mount all the different kinds and sizes of screws and bolts that you can find.

Use of Hand Screws

Hand screws are used for a great variety of purposes, e. g. :

1. To force two or more pieces together while gluing.
2. To hold work on the bench top while cutting mortises, scraping, etc.

3. To clamp pieces in position for boring holes.
4. To hold, by means of two or more hand screws, pieces of work at almost any angle.

When using hand screws:

1. **Keep the jaws parallel.**

This is accomplished by turning first the center, and then the outside screw. (See A and B, Fig. 35.)

Fig. 36 shows what happens when the jaws are not kept parallel:

- (1) The pieces are not held together properly and,
- (2) The screws may be broken, due to excessive bending.

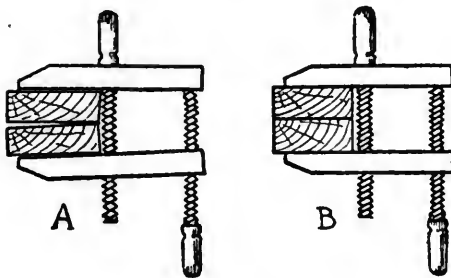

Fig. 35.

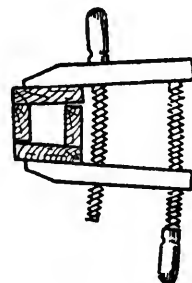

Fig. 36.

2. **Keep the jaws free from hard lumps of glue and bad scars, otherwise they will often mar your work.**
3. **Before gluing parts together—so that time may be saved in gluing—it is always wise to clamp them together in their proper positions so as to be sure:** (1) That everything is square and fitting properly, and (2) that the clamps will all work. The clamps and hand screws should then be taken off and piled so that they can be easily reached and adjusted after the glue is applied.

Reference Work:

1. Visit a woodworking shop and make sketches of all the clamping devices used.

2. Collect and mount pictures of all the clamping devices that you can find. Trade catalogs will furnish you many examples. You can put a piece of tracing paper over any picture, and by tracing get a sketch that will do for your collection. You should in every such case give the name of the book and the page on which the illustration was found.
3. What is a caul? Make a sketch of one.

Glue

Books that explain all about glue and how to use it are to be found in nearly all libraries. For this reason and to give you a method for research, it has been decided not to write much upon this matter, but rather to suggest that you investigate the subject about as follows:

1. Secure at least three books that contain something about glue and how to use it.
2. Tabulate all the statements made by the various authors. Note the repetitions and contradictions if any.
3. Arrange the statements into two groups, one telling facts about glue, the other how to use glue; and arrange them according to their importance.

It would be interesting to find out which author gave us the most information, which put his material into the clearest form, and the reasons each had for selecting the information given, while rejecting that offered by the others.

4. Arrange and perform a series of experiments to verify the statements made by the various authors, and record the results, whether successful or otherwise.

Reference and experimental work:

1. Make two glue joints—one with thoroly seasoned lumber, and the other with "green" lumber. Make the pieces of fairly good size and length.

2. Set them away in a warm dry place where the air can circulate freely about them.
3. Note what happens and draw your own conclusions. Would your conclusions be better if a dozen joints had been made with each kind of material and all had been treated alike? Might not one piece, for some unknown reason, act in an uncharacteristic manner?
4. Try the same experiment, but give the glued pieces one or two coats of shellac or varnish before setting them away. In place of the shellac, try the effect of stain alone; of filler alone.
5. Put some oil or grease on the surface of a joint and then attempt to glue the parts together. Does the joint hold well?
6. Why should end wood be sized before gluing?
7. How is a "rubbed joint" made?
8. Find out how glue is made and try to make some yourself.
9. Collect as many samples of glue and cement as possible and test their holding powers.

Be sure to keep a record of all your experiments. Try to devise a good form for your notes and do not neglect the date.

Verify these statements:

1. A thick layer of glue between two surfaces will not hold well. The strongest joint is made by covering both surfaces well with glue and then pressing them together as tightly as possible, thus forcing the glue into the fiber of the wood, for the holding is done by the hundreds of little needle-like projections that are thus formed.

2. Because of the fact that the needle-like projections are what hold the pieces together, the glue should never be chilled when it is applied, for if it is it will not penetrate well into the wood. Hence, the wood should be warmed if the very best results are to be obtained.
3. The harder the wood, the thinner the glue should be. Why? Experiment to determine the best thickness of glue to use on paper, cloth, white pine and white oak.
4. If glue gets onto a surface that is to be stained or finished, the stain will not penetrate because the fibers are already full of glue. Hence, before gluing work, would it be wise to stain or smear with soap any parts that might be stuck with the glue? Is there anything else that you could use in place of soap to protect the wood? See experiment No. 5. Most prepared glues will hold well if the parts are dry and properly fitted. They do not penetrate as deeply as hot glue on warm wood, but they dry more slowly. The inexperienced person will often get better results with the prepared glue than with the hot glue. Then, too, it is always ready for use.

Boring Tools

1. Look up the subject of bits and braces.
2. What is an auger bit, a gimlet bit, a twist drill?
3. Why will the twist drill work better in iron than the auger bit?
4. What is the use of the spur on the auger bit?
5. What does the worm do?
6. How are sizes of auger bits marked? Sizes of gimlet bits?
7. What is a hollow bit?

8. How can you bore thru a board without splintering it on the farther side?
9. Study the evolution of the boring tool, showing changes that have taken place in the cutting tool itself, in the method of turning it, in the method of pressing it to its work, in the method of holding it in the turning and pressing device. Start with the brad-awl, and, by means of pictures taken from trade catalogs, show the gradual changes that have taken place up to the power driven automatic drill and the boring mill.
9. Look up rock drills.

CHAPTER IX

THE COMMON JOINTS

If one has mastered the fundamental uses of the rule, the gage, and the square in laying out work; if he understands how to sharpen and use his chisel, his plane, and his saw, he should have little difficulty in cutting any joints that his work may require. It is somewhat beyond the scope of this book to deal at length with these matters. We will, however, make a few suggestions.

THE DADO JOINT

A dado is a rectangular groove cut across the grain of a board (Fig. 37) into which another member is fitted.

Laying Out the Joint

In making all joints the lay-out of the work is of equal importance with the cutting operations. If the lines are not where they belong, no amount of skill with the cutting tools will produce good results. Hence, there is need for skill in the correct use of the marking gage, the try-square, the knife, and the rule, not occasionally, but always. Until you have mastered these laying-out tools you are not ready to cut joints. When, however, you are sure that you can run straight lines and measure accurately proceed as follows:

1. Locate one side of the dado and square a knife line across the piece, remembering to square from the joint edge.
2. Locate and square the other side of the dado by measurement, or better, by superposition, i. e., by placing the piece A upon the piece B and marking its exact thickness.

3. Square the lines across the edges of piece B equal to the depth of the dado.
4. Set the gage to the required depth and gage between the two lines, on both edges. Be sure to gage from the face side.

Notes. In case of duplicate parts:

- (1) Measure all distances first on one piece and then transfer them to the others by means of the try-square and knife.
- (2) Gage all depths with one setting of the gage and remember to gage and square all lines from the two "marked surfaces," i. e., from the working face and the joint edge.

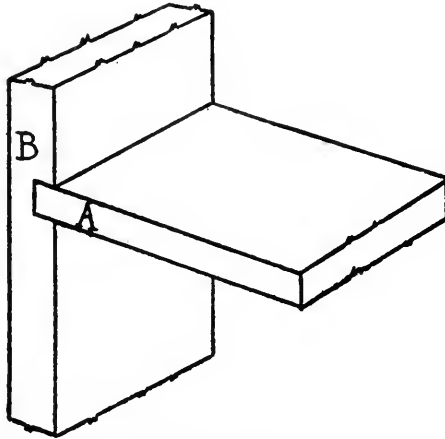

Fig. 37.

Cutting the Joint

1. Saw to the center of the knife lines keeping the saw kerf in the waste stock.
2. Chisel out the waste stock, working from both edges toward the center.
3. Test the bottom of the dado with a straight-edge to see that it is a true plane.

4. **If the sawing was not accurately done you must now pare to the center of the knife line with a chisel.**

Notes:

1. If the dado is a wide one, mechanics often tack or clamp a piece of wood across the board B (See Fig. 37) so that when the saw is pressed against the piece, it will cut just to the center of the knife line. Ask some good mechanic to show you how he does this.
2. If the groove does not run entirely across the board, it is called a gain. In this case the "blind end" of the gain must be bored or chiseled out and the rest of the joint sawed and chiseled as in the case of the dado.

Reference Work:

1. Ask some good mechanic to show you how he "gains" the treads and risers into the wall stringers in a flight of stairs.
2. Look up the definition of a rabbet joint, a grooved joint, a forked joint, and a cogged joint and make a sketch of each.
3. Find out and write up the method of making each of the above joints, and if you ever wish to use any of these joints in the construction of an article, be sure to try out your method first on some waste material.
4. As a supplementary problem make a screen and a box filing case, so that all joints that are made as preliminary practice pieces can be mounted and the written record of the method filed. This collection will gradually develop into a very valuable exhibit.

THE GLUE JOINT

1. **Arrange the boards so that the heart sides are alternately up and down.**

This is done to counteract the effects of warping. You can tell the heart side by looking at the annular rings on the ends of the pieces.

2. If possible, arrange them so that, after the joint is made you can plane all the pieces in one direction without splintering any of them.

Occasionally there may be other considerations, such as symmetry, beauty of grain, or defects of surface, that may outweigh either of the above considerations.

3. Mark the pieces so that you can reassemble them in the order and positions selected. Also numbering them 1, 2, 3, etc.
4. "Joint" the inner edge of piece No. 1, i. e., the edge next to piece No. 2.

Since no face side has been planed, no test can be applied except to sight down from end to end. If, however, the board is not badly in wind or warped, a try-square may be used to get the edge at about right angles to the wide faces.

5. Fit the edge of piece No. 2 that is to come in contact with piece No. 1, to the edge of piece No. 1 that has just been jointed.

Piece No. 2 is not properly fitted until: (1) the wide faces of both boards are approximately in the same plane; and (2) the edges are in contact from end to end and from side to side.

6. Plane and fit each of the remaining joints.
7. Glue and clamp in position.

THE MORTISE-AND-TENON JOINT

There are a great many modifications of this joint. It would be well to look up and make sketches of the thru mortise-and-tenon, the blind mortise-and-tenon, the keyed, the stub, the wedged, the fox, and the dove tail mortise-and-tenon.

Laying Out the Joint

Remember that you are not ready to cut joints until you have mastered the uses of the rule, the gage, and the try-square, for, if the lines are not where they belong no amount of skill with the cutting tools will produce good results.

In general, the lay-out of the joints should be made as follows:

1. Measure all distances lengthwise of the grain.

These measurements should all be made from a fixed starting point, either the center of the piece, or the end first squared. In case of duplicate parts, measure the lengths first on one piece and then transfer them to the others by means of the try-square and knife.

2. Scribe all cross-lines with knife and try-square.

Work always from the working faces, and stop all lines so that they will not show upon the finished surfaces. The graduations on the try-square make this possible.

3. Lay out the bevel cuts if there are any.

Bevel cuts are best laid out by means of a T-bevel, altho they can be laid out by measurement.

4. Run all gage lines.

Gage always from one of the face surfaces, and in case of duplicate parts gage all with one setting of the gage.

Pointers:

- (1) Always lay out the work on both sides of the board, if the cut is to run thru.
- (2) Plan the work so that the face sides will come together, and whenever possible bring the shoulders of the tenons against one of the face surfaces. Why?

Cutting the Mortise

See that the ends of the mortise are laid out with a knife line, and in case of a thru mortise see that the work is laid out on both sides. There are, of course, a number of ways to cut out a mortise.

Some prefer to bore out the center, especially when the mortise is large and made in hard wood; and then, starting in the center, to pare out to the knife and gage lines, always taking thin shavings when near the lines.

A second method is to begin in the center of the mortise with a V-shaped cut, the cut being taken across the grain, and then continue to the ends of the mortise with vertical cuts. The flat side of the chisel is always kept toward the end that is being approached. This method is especially use-

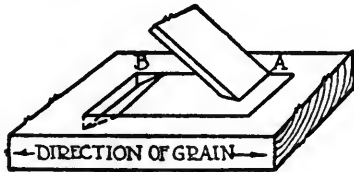

Fig. 38.

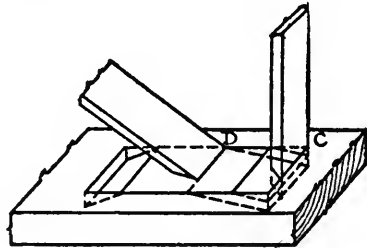

Fig. 39.

ful where the chisel is as wide as the mortise, and in the case of mortises that do not go thru.

There is, however, another method that is considered best practice among mechanics.

1. **Set the chisel as at A (Fig. 38) and cut toward the end of the mortise.**

Note that the edge of the chisel is cutting across the grain. After the cut has been made it will look as at B. If the mortise is wider than the chisel, as shown here, more than one cut must be made.

2. **Set the chisel in a vertical position as shown at C (Fig. 39). Note that the flat side of the chisel is against the end of the mortise. Tap gently with the mallet, thus forcing the chisel into the wood as shown by the dotted lines.**

Do not drive the chisel down deeply, for the wedge action of the chisel might crowd the flat of the chisel over beyond the line

3. **Set the chisel as at D, and cut toward the end of the mortise, as indicated by the dotted lines.**
4. **Repeat these operations until the cut is of the required depth, or half way thru in case of a thru mortise.**
5. **Repeat at the other end of the mortise.**
If the mortise is narrow and long it is probably best to work back with slanting cuts, prying out the core at each stroke of the chisel until within about $\frac{1}{8}$ " of the other end; then turn the chisel over so that the flat side is toward the end of the mortise and finish the cut.
6. **Turn the piece over, if the mortise goes thru, and repeat.**
When the ends of the mortise are cut thru, the core can be pared away with slanting cuts until it will crush thru.
7. **Pare out the sides and, if necessary, the ends of the mortise until they are true planes. Test these surfaces with the straight edge of the chisel.**
In all this work one must be careful not to mar the ends of the mortise by prying down over them.

In the case of a blind mortise devise some method for testing whether or not the sides of the mortise are at right angles to the surface. One might use a plug with parallel sides as a help in the solution of this problem.

Cutting the Tenon

In cutting tenons the mechanic aims to saw to the center of the knife and gage lines so that there will be little or no paring to do with the chisel.

1. **Do all of the rip sawing first.**
2. **Crosscut to the shoulder lines.**
Note: If the method were reversed some of the lines would be lost on a tenon that had four shoulders.
3. **If necessary, pare to the lines with a chisel. Never use a file or sand paper for this purpose.**

Reference and Experimental Work: Look up and make sketches of:

1. The plain miter and the splined miter joint.
2. The box dove tail and the lap or drawer dove tail joint.
3. A fished joint.
4. Draw bolted butt joint.
5. A matched and beaded joint.

The encyclopedias usually contain information along this line. Let each member of the class select a joint; inquire of some good mechanics how to make it; write up the method and then make a good joint. These joints, together with the written method used, can be mounted upon a large board. This is a typical illustration of the advantages gained by subdivision of labor and team work. No one has to look up the method of making more than one joint and yet, when the work is completed, all can easily learn how to make any of the joints by referring to the exhibit.

CHAPTER X

WOOD FINISHING

Wood is finished to protect it from moisture and dirt and to give it a color that will harmonize with its surroundings. For out of door work paint is usually used, but because paint conceals the grain of wood, it is seldom used on furniture.

Staining and Polishing

Before starting to stain or polish your work look up scraping, sand papering, and the experimental work suggested at the end of this section. The complete process of staining and finishing is as follows:

1. **Stain the wood any desired color.** Wipe out the "laps" with a cloth, and sand the surfaces lightly after the stain is dry, not enough to cut thru, but enough to bring out the grain. The work may then need a second light coat of stain.

There are three classes of stain—water, spirit, and oil.

1. The water stains come in a wide range of colors. They penetrate well and are inexpensive, but they raise the grain of the wood badly, and so require a great deal of sanding.
 2. The spirit stains also come in a wide range of colors. They penetrate well and raise the grain of the wood but very little. They are, however, rather expensive.
 3. The oil stains range in price between the spirit and the water stains. They do not raise the grain of the wood, but they will not penetrate deeply.
2. **If the wood is open grained it must now be filled.**

The filler comes ground in oil. It should be thinned with turpentine, benzine, naphtha, or gasoline, until it is about as thick as cream. Apply the filler with a brush and allow it to set about fifteen minutes, or until it begins to look "flat". Then wipe off across the grain using burlap or shavings.

Prepared fillers can be obtained, stained almost any desired color, or the natural filler can be darkened with burnt sienna, raw umber, Van Dyke brown, or drop black. These and many other colors can now be obtained in collapsible tubes.

3. **When dry, sand lightly; not enough to cut thru, but enough to make the surface feel smooth to the hand.** Be especially careful of the sharp edges. If you cut thru them they will always show lighter than the rest.
4. **Wax and polish, using prepared floor wax.** This gives a beautiful finish. It is easily applied, and the finish easily renewed whenever it becomes dull or spotted.
5. **In place of the wax, white shellac, varnish, or any similar finish may be applied.** When dry, sand with very fine sand paper, sanding always in the direction of the grain. Shellac or varnish should be applied only in a warm, dry room that is free from dust. Dust is especially bad, for every particle that settles on the work will show unless removed entirely with sand paper or pumice-stone before the next coat is applied. Shellac is a solution of lac and alcohol. It therefore dries very quickly; hence, one must not attempt to do much "brushing out" with shellac. If one does, the alcohol in the brush will only soften up some parts more than others, thus piling up the finish in some places while drawing it away from others. Several thin coats of shellac, each carefully sanded after it is thoroly dry, will give the best results.
6. **Wax may now be applied or the work given as many coats of shellac, varnish, or other finish, as desired.** Each coat should be given ample time to dry, and then be sanded before the next coat is applied. Pumice-stone and water may be used in place of sand paper to rub down the surfaces. Since varnish and shellac do not work well over oil, pumice-stone and oil should be used only for the final rubbing or polishing. Several coats of shellac or varnish, each rubbed down well, will fill any surface, but for open grained woods like oak or chestnut the prepared rock filler is cheaper, quicker, and just as satisfactory. For close grained woods the shellac or varnish is to be preferred.

Experimental Work:

A good finish can never be given to wood unless the surfaces have been made true and smooth with the plane, the scraper, and sand paper. Scratches and torn places only show worse after the finish is applied.

To convince yourself that this is true:

1. Find a cross-grained board that tears somewhat under the plane. Plane, scrape, and sand a wide surface, an edge, and an end until they are as true and smooth as you can make them. Plane the other surfaces but do not scrape or sand out the torn places left by the plane. You might, however, do a little sanding across the grain, using coarse sand paper, but not enough to remove the torn places.
2. Stain and finish all the surfaces in the same manner, using the same materials on all and following the order of steps given above. The results obtained will be very convincing.

Fuming Oak and Chestnut

On oak and chestnut the process of fuming may be substituted for that of staining. This process of fuming may be described as follows:

1. **Dissolve some tannic acid in an equal amount of water.**
Commercial tannic acid is the pulverized inner bark of the white oak tree.
2. **Paint the surfaces of the wood with the solution of tannic acid.**

Chestnut and some kinds of white oak can be fumed without painting the surfaces with tannic acid. The results are, however, seldom as satisfactory when this work is omitted. You might try some experiments to satisfy yourself upon this point.

3. Place the articles to be fumed, together with a sufficient amount of concentrated ammonia to saturate the air with the ammonia fumes, into a closed box or room. The ammonia should be placed in shallow dishes. Be careful to expose all surfaces that you wish darkened, to the action of the ammonia fumes.

A large packing box may be lined with paper for this purpose, or the door of a closet may be fitted with weather strips. A glass window somewhere in the box or the door of the room will permit one to observe the changes as they take place. It usually requires from ten to twenty-four hours to darken the wood properly.

4. The fuming will raise the grain of the wood. It must, therefore, be sanded down well before filling and finishing.

Sometimes, when the fuming has been a little irregular, it is wise to even up the color with some brown stain after the fuming and sanding have been completed.

5. Fill and finish as already explained.

Oil Finishing

Boiled linseed oil "cut" in a little turpentine makes a very good finish. It is especially good on close grained woods such as mahogany, cherry, black walnut, or yellow pine. If a natural color is wanted it is only necessary to brush or rub the oil and turpentine on the surfaces. For this operation a rag will do quite as well as a brush. After the oil has penetrated as deeply as possible, i. e., after about ten or twelve hours, the surfaces should be polished by rubbing. The rubbing should be done lengthwise of the grain, and if the best results are desired, repeated day after day for several days. This finish darkens and enriches the color of the wood somewhat, and if it is oiled and polished occasionally it will improve with age.

Experimental Work:

1. Try several proportions of boiled linseed oil and turpentine to determine the best proportions to use. Try the effect of adding a little japan drier. Try raw linseed oil instead of the boiled. Does it dry as fast or faster than the boiled?
2. Make up a set of samples, using:
 - (a) Water stains; (b) spirit stains; (c) oil stains; (d) fumed pieces, filling and polishing the open grained woods, but simply polishing those with a close grain.

Manufacturers of stains and polishes will gladly send you samples of their products and instructions for using them if you will write to them and state your purpose. Look for their advertisements in any trade journal, also in the manual and industrial arts magazines.

3. Make up a set of samples using colors ground in oil. Add a little oil and thin with turpentine.

Care of Brushes

Varnish and filler brushes can be cleaned with turpentine, benzine, naphtha, or gasoline, and then the turpentine or other cleanser may be put into the jar of filler, so that there is no waste. Shellac brushes can be cleaned with alcohol, and then the alcohol put into the shellac.

Water and spirit stains do not ordinarily stiffen the brushes so that they do not need to be cleaned after using. The brushes should be clearly labeled and hung up after using, and always used for the same purpose.

The Stain Bench

The drawings (Fig. 40) show a satisfactory arrangement of containers and covers for stains and finishes.

The containers are granite pails about six inches in diameter and four inches high. These pails are set on blocks which

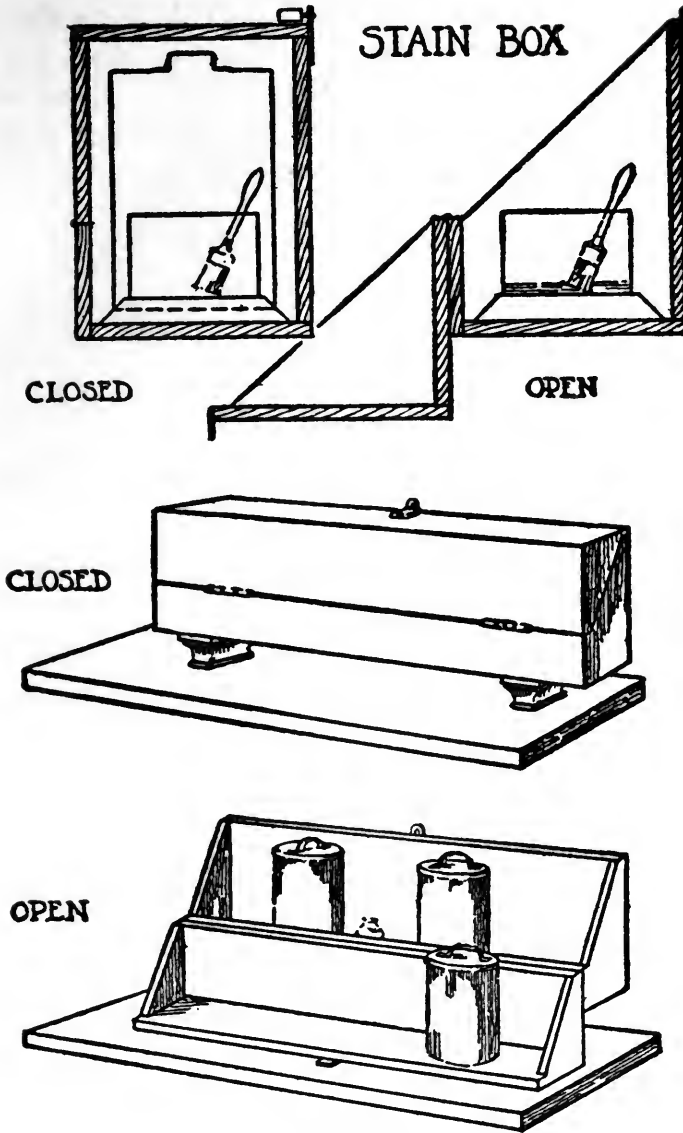

Fig. 40.

are fastened to the bottom of the inclosing box. When not in use the stain in the container is protected from the air by a metal cover seven inches in diameter and ten inches high. The container, brush, cover, and block are all given the same

number to avoid mistakes in returning things to their proper places. Several containers and covers are inclosed in one long box, the lid of which forms a shelf when open, as shown in the drawings (Fig. 40). The box can be locked with a padlock when not in use, thus preventing misuse of the bench and finishes.

Reference Work:

1. Find out how the following articles are made, and when they are used: turpentine, linseed oil (boiled and raw), benzine, resin, drier, japan, white lead, zinc oxide, putty, spirit stain, water stain, copal varnish, shellac varnish, rubber set brushes, and pumice-stone.
2. Try to collect the raw materials and make: (1) linseed oil; (2) rosin; (3) turpentine; (4) lamp black; (5) vegetable dyes—it will be well to tone down your dyes with lamp black; (6) filler; (7) wax; (8) brushes. Experiment with pieces of tin, with old dust brushes, and other inexpensive materials. You may find that you can make brushes that will do very well indeed for applying stain and filler and so save your good brushes for shellac and varnish.
3. Look up the subject of house painting. Collect several brands of paint, and prepare and paint samples. Expose some samples to the action of the weather. Try out various proportions of turpentine, lead, and oil; turpentine, lead, zinc oxide and oil, to determine the best wearing qualities for out of door work. Experiment with colors.

CHAPTER XI

LUMBERING

One ought never to work long in any material without making a real study of its characteristics and its sources. Lumber has grain; it warps and shrinks and is subject to many defects. It comes in many standard sizes and shapes. You should start at once to observe and jot down every fact concerning these matters that you can discover. Here are a few suggestions:

1. Go to your lumber dealer or some good carpenter and inquire of him what the standard defects are in lumber, e. g., sap wood, pitch pockets, waness, heart shakes, cup shakes and wind shakes. Ask him to show you examples of each and if possible make a collection of them and other defects such as: dry rot, worm holes, and knots. Ask him to explain what he means by "A stock" in yellow pine or white oak; B, C, and D stock; No. 1, No. 2, and No. 3 common. Ask him to show you the difference between plain and quarter-sawed oak.
2. Try a few experiments.
 1. Get a few short logs 10" or 12" in diameter.
 2. Saw each log in half.
 3. Saw boards out of each log to illustrate plain and quarter-sawing.
 4. Keep a record to show the percentage of weight that is lost in the saw dust, and the amount that turns out to be bark or edgings rather than useful boards.
 5. Keep a record to show how much weight is lost in drying the boards.

6. Set the boards on edge so that the air has free access to both sides of each piece and note (1) which way the boards warp; (2) how much they shrink edgewise and endwise; (3) how they check.
7. Try to learn how lumber should be piled in order to dry thoroly and yet not warp.
8. Try to learn what methods are used to dry lumber rapidly.
9. Try to learn what uses are being made of the saw dust, the edgings, bark, and other pieces that were once wasted at the saw mills.

The druggist, or a book on industrial chemistry will help in this inquiry. Start in with a study of wood alcohol, tannic acid, and turpentine.

10. Make a sketch of a tree trunk, showing: (1) the pith, (2) the medullary rays, (3) the annual rings, (4) heart wood, (5) sapwood, (6) cambium, (7) bast, (8) outer bark.

You might be told just what books to read, just to what department of the United States Government to write for information, but if you were, you would be robbed of part of the fun of the search. Make a game of this investigation, see who can bring in the most specimens, pictures, and information. Sort out and classify your finds and finally make a case for them and a file for your written notes.

CHAPTER XII

SUGGESTIONS TO TEACHERS

Method:

Our experience with boys of eleven to fourteen years would seem to indicate a peculiar proneness to pick out and learn all the accidental or relatively unimportant matter that can be found in a text book, while often ignoring things of real importance. Undoubtedly training is needed to overcome this habit. We have chosen, by using two sizes of type, to help the boy in this matter and, if possible, to "put things up to him" in such a way that there can be no dodging.

On the other hand, if the boy will undertake the reference and experimental work suggested, there will be ample opportunity for him to exercise his powers of discrimination and analysis. If the boy finds any unfamiliar words in the text it should be his business to look them up in the dictionary. All the crafts have a few technical words that the young mechanic should learn as soon as possible. A dictionary should, therefore, be part of the equipment of every shop.

Reference and Experimental Work:

Do not let the reference and experimental work trouble you. We have suggested much more than any one class should ever undertake. Do as much or as little of it as you find of interest and value. We have found that for many reasons—illness, transfers, inability, or unusual ability—there are always some boys that get out of step with the rest of the class. They need special attention. This, the conscientious teacher, if he is to deal justly with the faith-

ful majority, cannot always give immediately. At such times we have found a well selected shelf of books to be a wonderful help. We have assigned the topics suggested for reference or experimental work, and have seldom been disappointed in the results secured. Indeed, we believe that a boy's curiosity, guided somewhat by the master, will often discount all the master's grown-up analysis of the subject, all his careful grading of difficulties. For, once the boy has caught a glimpse of the light and is filled with a desire to reach it, his zeal and enthusiasm will make short work of many difficulties. We do not, however, discount the value of the master. He leads the way after all, and it is his counsel that helps to fix standards and ideals in the boy's mind.

Shop Organization:

The shop teacher has a great many tools and supplies to care for. If he attempts to attend to all these matters personally he will find himself burdened with his duties. On the other hand, if he is a good organizer and manager he can, by calling the boys to his assistance, make this part of the work a real satisfaction and at the same time give to his boys a training in responsibility and leadership that is of supreme interest and importance.

We have learned to appoint the best and most reliable boys as inspectors, tool experts, and shop foremen. Our system works out about as follows:

1. **One boy in each row is appointed an inspector. It is his duty to inspect at the beginning and at the end of each class period, the condition of each bench in his row. If he finds any tool missing he reports the same to the shop foreman; otherwise he reports everything O. K. The shop foreman records this report in his book.**

2. An inspector is appointed:

1. For the general tool case.
2. For the stain table.
3. For the drawing boards.
4. For the clamp table.
5. For the lumber rack.

Each of these inspectors report to the shop foreman and the shop foreman records their reports in his book.

3. A tool expert is appointed to help others grind their plane irons and chisels. He is selected because he is the best mechanic in the class. He is only asked to serve when the teacher finds it impossible to attend to the grinding personally.

Some may think this a rather complicated organization to maintain. We do not find it so. Indeed, it saves us a great deal of time. The boys are able to perform their duties in about three minutes daily, and if the teacher is systematic himself in checking up the inspectors and the records of his shop foreman, he will find that the boys have kept house for him in splendid fashion.

A few inquiries into the organization of the best industrial shops, made at the time the inspectors, tool expert, and shop foreman are appointed, and a little study of the evolution of foremen and superintendents will convince the boys that it is an honor to be asked to serve in this capacity, and that the training involved is of great value. The idea can be pressed still further. One or more shop draftsmen may be selected to put drawings or written work on the board; one or more "jig" experts appointed to construct jigs so that certain jobs can be worked out rapidly. In this way every ambitious boy can be given an opportunity that means training for leadership and responsibility.

How to Keep up Interest in Drill Work:

Skill in using the various tools is essential if satisfactory

results are to be secured. We have learned to make a game of this part of our work. We can hardly go into the details of our methods, our score cards, and our inter-class contests. The ingenious teacher with the help of his boys should be able to solve the problem. We learned the trick from the elementary grade teachers of our acquaintance.

Manual Training Equipment:

As a matter of suggestion we are giving a list of tools for a manual training equipment.

For 96 students in four sections of 24 each.

- 24 10 pt. 22" Crosscut Saws (Disston's No. 8; Atkins' No. 153; or Bishop's).
- 24 No. 3 Smooth Planes (Bailey).
- 24 No. 65 Stanley Marking Gages .
- 24 No. 20 Stanley 9" Try-squares.
- 24 No. 60 Steel Rules 12", Lufkin's Etched.
- 24 Oilstones—Indian Medium, Iron Box.
- 12 Copperized Steel Oilers, 2¼" Nozzle, ¼ Pint.
- 24 Bench Brushes, Solid Back.
- 24 Hickory Mallets, Round Head (3"x5").
- 24 Drawing Boards—Springfield Inds. No. 2 Drawing Kits Milton Bradley Co.
- 24 No. 576 Eagle Compasses.
- 72 Double Irons to fit No. 3 Smooth Planes, 1¾" Cutter.
- 96 No. 1 Sloyd Knives, 2½" Blade.
- 24 S. F. Chisels, ¼", Buck Bros. No. 35.
- 24 S. F. Chisels, ⅜".
- 12 Rip Saws, 8 Pt. 22", Atkins' No. 53.
- 12 Hammers, 7 oz. Ball Face Claw—Maydoles.
- 9 Bit Braces, No. 14-6", Plain Barber.
- 9 Framing Squares, 2 ft.—Nichols.

- 9 Gimlet Bits, 3-32".
- 9 Gimlet Bits, 4-32".
- 9 Gimlet Bits, 5-32".
- 9 Gimlet Bits, 6-32".
- 9 Gimlet Bits, 7-32".
- 9 Countersinks No. 4—Rose.
- 6 Dowel Bits, $\frac{1}{4}$ "—Russel Jennings Augers 102.
- 6 Dowel Bits, $\frac{3}{8}$ " ("Mephisto")—W. A. Ives Co., Wallingford, Conn.
- 1 Set Auger Bits, $\frac{1}{4}$ " to 1" by $\frac{1}{16}$ ths ("Mephisto")—W. A. Ives Co., Wallingford, Conn.
- 12 Cabinet Maker's Clamps, 4 Ft.—Sheldon's.
- 4 Screw Drivers, 3"—Champion.
- 4 Screw Drivers, 5"—Champion.
- 4 Screw Drivers, 7"—Champion.
- 24 Cabinet Scrapers, $2\frac{1}{2}$ "x6"—Atkins' 2.
- 12 Nail Sets—Syracuse.
- 3 Wing Dividers, 8"—(PSW.)
- 2 Dowel Plates—Wm. Johnson 78.
- 1 Knife Handle Monkey Wrench, 12"—Coes.
- 12 Saw Files (5" Slim Taper)—American.
- 2 Turning Saw Frames with rod, 14".
- 1 Flat Lip Side Cutting Pliers No. 50, 8".
- 12 Saws for 14" Disston Frame.
- 3 Sliding T-Bevel, 25-12".
- 24 American Mill Bastard Files, 10".
- 24 American Mill Bastard Files, 12- $\frac{1}{2}$ Rd.
- 6 Burnishers, Rd. or Oval, Disston.
- 1 Miter Box, Perfection.
- 1 Nest of Keyhole, Compass and Pruning Saws, Disston's.
- 2 Garbage Cans, No. 75 W. C. Co.
- 24 Tin Cups, 1 Qt.
- 6 Galv. Stain Covers with open end, Diam. 7", Ht. 10".

- 1 Lmp. Adj. Exp. Bit—C. E. Jennings.
- 6 Granite Pails, No. 22-R, 6" Diam.
- 12 Peerless Jorgensen Clamps, 8".
- 12 Peerless Jorgensen Clamps, 10".
- 12 Hand Scrapers, No. 81—Stanley.
- 4 No. 7 Bailey Planes 22" long by 2 $\frac{3}{8}$ " Cutter.
- 4 No. 5 Bailey Planes 14" long by 2" Cutter.
- 24 Chisels, $\frac{3}{4}$ "—Buck Bros. No. 35.
- 2 Pike Peerless Senior Corundum Tool Grinders.
- 1 Gal. Machine Oil (Polarine in container).
- 12 Box letter files.
- 2000 Thumb Tacks.
- 1 Bale (100 lbs.) washed sanitary rags.
- 24 "End-gate" nuts, 5-16". For tool racks.
- 24 Bolts to fit end-gate nuts, 5-16"x8". For tool racks.
- 1 Gross No. 110 Bright wire screw eyes. " " "
- 1 Gross No. 109 Bright wire screw eyes. " " "
- 1 Gross No. 910 Bright wire screw eyes. " " "
- 1 No. 4272 Popular 15" Blade Cardboard Cutter—Milton Bradley Co.
- 24 Burlington Model Benches, top 22"x52", fitted with No. 10 vise, or equal, E. H. Sheldon & Co., Muskegon, Mich.
- 1 Double Section Wall Case (6 ft. long by 6 $\frac{1}{2}$ ft. high); upper section to have $\frac{7}{8}$ " back, but no shelves; or equal, E. H. Sheldon & Co., Muskegon, Mich.

INDEX

(NUMBERS REFER TO PAGES)

A

Angle of Chisel.....34, 35
Angle of Plane Iron.....34, 35
Assembly Drawing 9

B

Bill of Materials.....11
Block Plane32, 33
Boring for Screws.....46
Boring Tools50
Brushes64
Burnisher42

C

Cap Iron28, 29
Chisel40, 41
Chisel, Angle of Bevel....34, 35
Compasses24
Containers for Stain.....64
Conventions, Dimensioning15
Crosscut Saw25, 26
Cutting Curved Outlines.....41
Cutting Edges of Plane Irons..29

D

Dado Joint52, 53
Dividers24
Drawing 9
Drawing, Assembly 9
Drawing, Detail10
Drawing, Scale16
Duplicate Parts39

E

Edge Planing31
End Planing32
Equipment72

F

Files42
Filler60
Finishing, Wood60
Form Work40
Frog of Plane.....28
Fuming Wood62

G

Gage22, 23
Glue48
Glue Joint54
Grinding Tools34
Grindstone34, 35

H

Hand Screws46, 47
Hexagon, Construction of....18

J

Jack Plane30
Joint52, 53, 54, 55
Joint, Cutting53
Joint, Dado52, 53
Joint Edge37
Joint, Glue54
Joint, Mortise-and-Tenon55
Jointer Plane31

L

Lag Screws	46
Laying-out Tools	20
Lettering	16
Lines, Conventional	17
Lines, Indefinite Length.....	13
Lumbering	67

M

Measuring Tools	20
Method of Procedure	7
Mortise	56
Mortise-and-Tenon Joint.....	55, 56, 57, 58

N

Nailing	43
---------------	----

O

Octagon, Construction of.....	19
Oil Finish	63
Oilstone	34

P

Perspective View	15
Plane	28, 29, 30
Plane Adjustments	28
Plane, Angle of Bevel.....	34, 35
Plane, Block	32, 33
Plane Cap Iron.....	28, 29
Plane, Jack	30
Plane, Jointer	31
Plane, Smooth	30
Planing, Edge	31
Planing, End	32
Polishing Wood	60

R

Rip Saw	25
Rule	20

S

Sand Paper	43
Saw	25, 26
Saw, Crosscut	25, 26
Saw Kerf	25
Saw, Rip	26
Scale Drawing	16
Scraper	42
Screws	45
Screws, Boring for.....	46
Shellac	61
Smooth Plane	30
Squaring Stock to Dimensions.	37
Stain	60
Stain Bench	64
Stain Containers	64, 65
Steel Square	24

T

T-bevel	23
Teeth of Saws.....	25, 26
Tenon	58
Title of Drawing.....	17
Tools Needed in Manual Train- ing Shop	72
Triangles	13
Try-square	20
T-square	12

V

Varnish	61
---------------	----

W

Wax	61
Whetting	34
Winding Sticks	30, 31
Witness Marks	37
Wood Finishing	60
Working Face	37

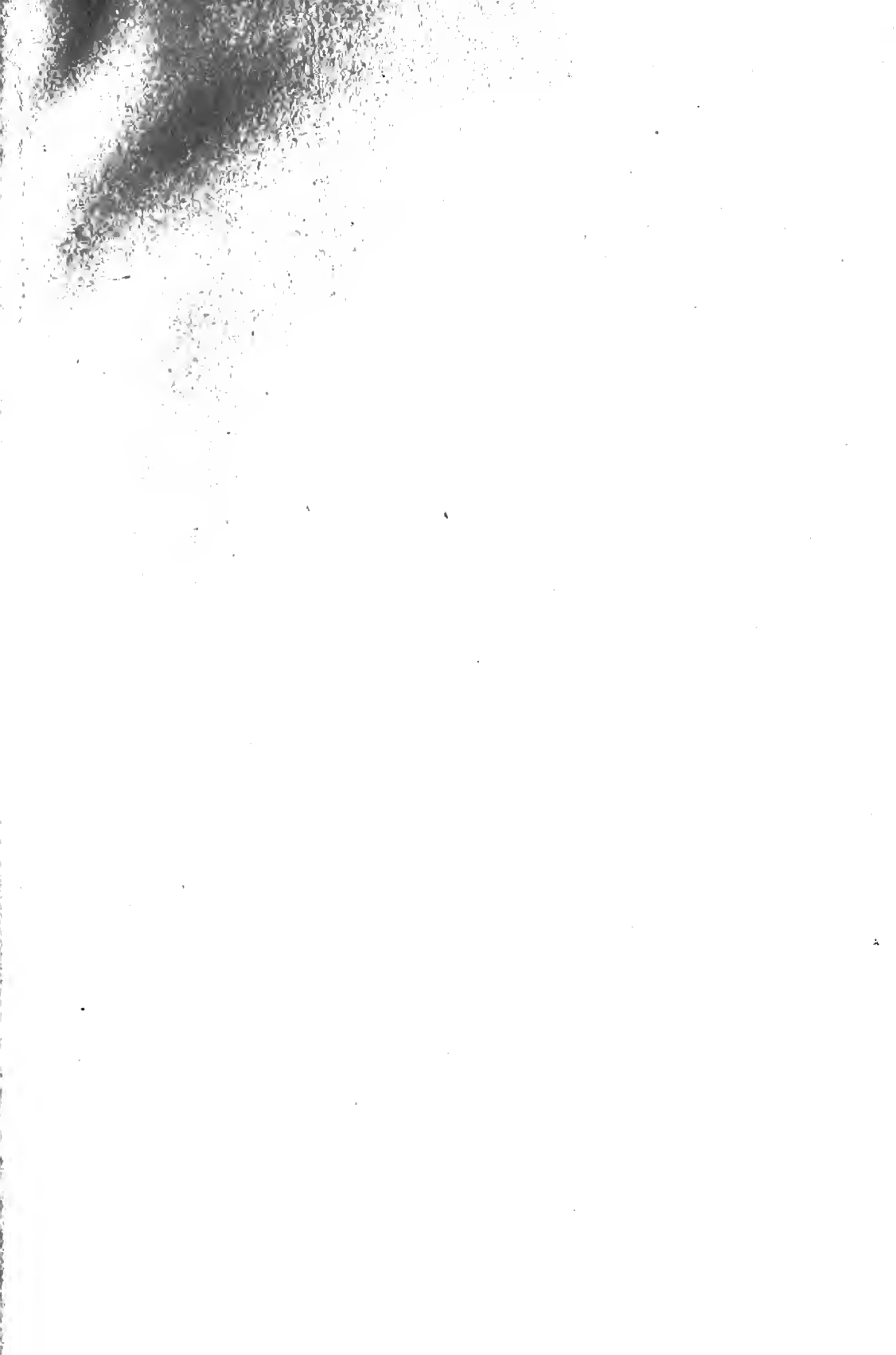





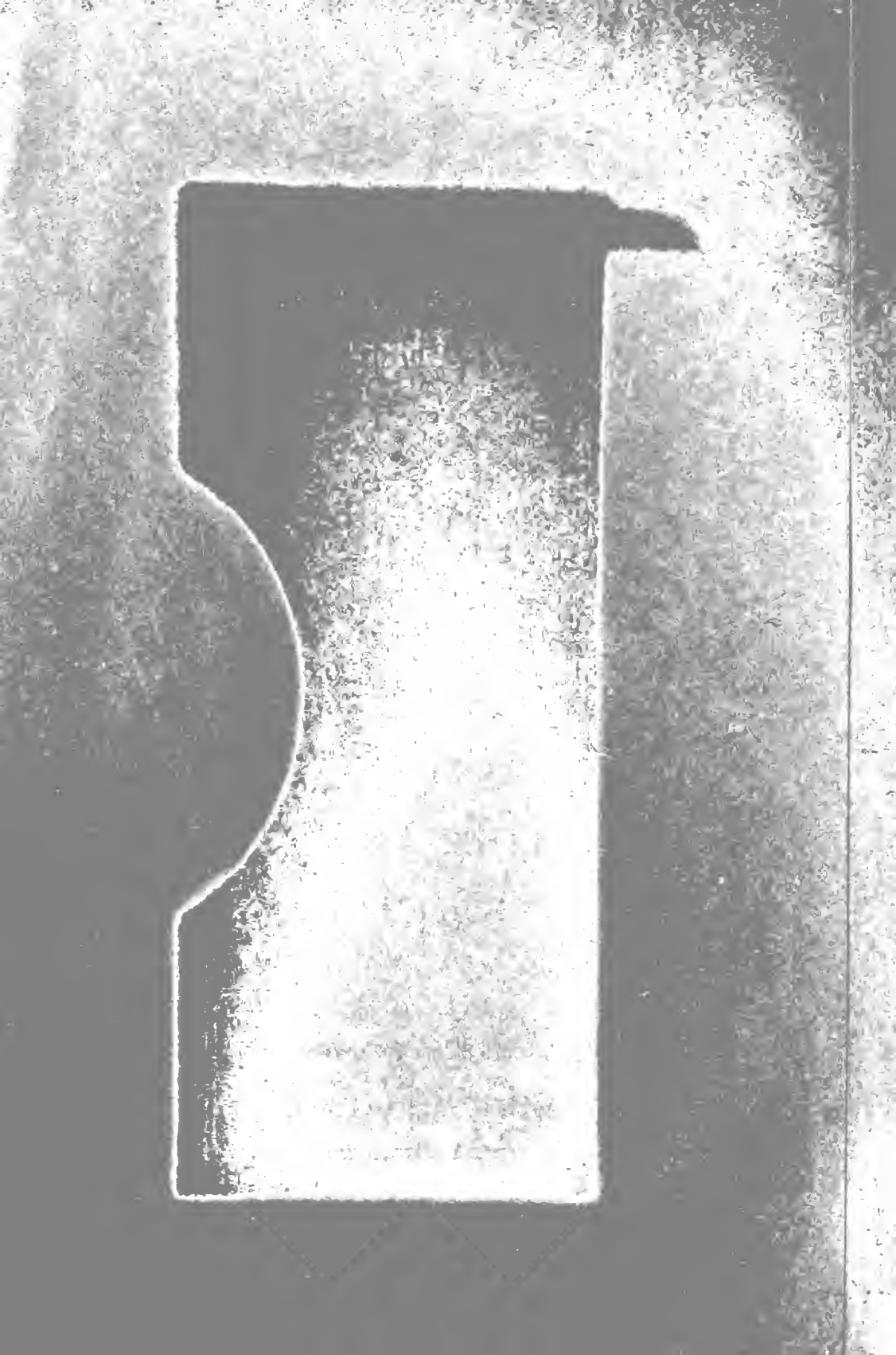

155696

Educat.
Commerc.
L.

Author Laughlin, A. P.

Title Tool processes in woodworking.

University of Toronto
Library

DO NOT
REMOVE
THE
CARD
FROM
THIS
POCKET

Acme Library Card Pocket
Under Pat. "Ref. Index File"
Made by LIBRARY BUREAU

