

UC-NRLF



QB 17 282

ELEMENTARY SLOYD AND WHITTLING LARSSON



SILVER BURDETT & COMPANY



CLASS OF BOYS AT WORK

ELEMENTARY SLOYD

AND

WHITTLING

With Drawings and Working Directions

BY

Gustaf Larsson

Principal of the Sloyd Training School, Boston, Massachusetts



SILVER, BURDETT AND COMPANY
NEW YORK BOSTON CHICAGO

LB1599
W6L3

GENERAL

Copyright, 1906, by

SILVER, BURDETT AND COMPANY

A. M. C

CONTENTS

	PAGE
INTRODUCTION	1
WOODS OR TIMBER	5
TOOLS AND IMPLEMENTS FOR ELEMENTARY SLOYD (ILLUSTRATED):.....	12
LIST OF TOOLS AND MATERIALS.....	17
WORKING DIRECTIONS FOR ELEMENTARY SLOYD (ILLUSTRATED).....	37
STAINING AND POLISHING.....	65
WHITTLING	69
GENERAL DIRECTIONS	70
WORKING DIRECTIONS FOR WHITTLING (ILLUSTRATED).....	72
OUTFIT OF TOOLS AND MATERIALS (ILLUSTRATED).....	93
SPONTANEOUS CREATIONS BY CHILDREN UNDER TWELVE YEARS OF AGE (ILLUSTRATED).....	96



INTRODUCTION

SLOYD is tool work so arranged and employed as to stimulate and promote vigorous, intelligent self-activity for a purpose which the worker recognizes as good. By "Elementary Sloyd" is meant bench work in wood, in two dimensions adapted to children from eight to twelve years of age. In 1889 I published a series of working drawings for "Preliminary Sloyd" with a teachers' "Sloyd Manual of Working Directions." The changes and improvements made since that time are the results gained from the experience of many teachers, and are embodied in the course here outlined.

It is thought by some that children under twelve years of age have not the requisite strength and maturity to handle ordinary wood-working tools, but, owing to the recognized necessity of providing for the vigorous muscular activity of younger children, this course is suggested.

I have endeavored to select larger objects than those commonly given children at this age, so that they may obtain more physical exercise, and, although a good finish should be insisted upon, less accuracy is required. The objects are chosen with special reference to the interests of a child at this age, and are different from those which have been suggested for the three upper grammar grades. This course may include toys and games which appeal to young children.

Many of the objects in this course have been evolved after a careful study of a large variety of children's original work in wood.

Whether we should always allow children to select what they may choose to make, or whether some consideration of logical sequence or graded effort should underlie the work, can best be decided by visiting schools and carefully observing classes engaged in actual work under

INTRODUCTION

different conditions. The point is, I believe, that we should find out whether or not what the child would *like* to do harmonizes with the educational idea of what he had *best* do. For myself, I believe fully in the value of spontaneity in educational work. I also believe that spontaneity may be guided, greatly to the advantage of the child.

The many different kinds of handiwork now experimented with in the lower grades of our public schools are, without doubt, of much value when given by a teacher thoroughly competent and interested in his work, and they also have the advantage of being taught in the regular schoolroom, by the regular grade teacher, and with inexpensive outfit. Such work, however, can never take the place of sloyd, which, with its large variety of tools and exercises, provides for more free and vigorous muscular movements and offers a more stimulating motive to the worker in the objects which he makes.

"Elementary Sloyd" is suggested for use in the fifth and sixth grammar grades, and also for any special classes, public or private, given at home clubs, settlements, summer schools, etc. It requires a special room equipped with suitable benches and tools. The number of children in the class should be limited to twenty.

The teacher should have training and experience, as well as a good knowledge of the correct use and care of tools and of the best methods of performing the various exercises.

The drawings, models, tools, and material are simpler than those used in the upper grades. Generally, only one view is given in the drawing, and only the necessary facts for the construction shown. The directions are brief, being intended merely as hints for methods of procedure.

While these drawings and directions are intended primarily for the use of the teacher, the children may work from them directly, after they have gained some facility in the use of tools and in the ability to read

INTRODUCTION

drawings. It should be understood, however, that no directions or drawings can take the place of the teacher.

In order to give the children a clear idea of what they are to do, the teacher should first present the model, and, by questions and explanations, lead the children to a correct understanding of both the model and its use. Enlarged blackboard drawings should be made for the children to read, and they may also be taught to make sketches and simple working drawings.

As a general rule, the method of procedure should be:

First: From the model.

Second: From model and drawing.

Third: From drawing alone.

Fourth: From the children's own suggestions guided by the teacher.

Correct working positions should be insisted upon; self-reliance and generosity should be fostered, and it must be remembered that the finished product should represent the child's own effort.

There is often a vague idea as to what is meant by the educational value of manual training. I would suggest, to make this subject clear, that, while the children are at work, the following questions should be satisfactorily answered by supervisors, teachers, or visitors:

First. Are the child's positions and movements while working such as are likely to be injurious or beneficial to his physical development?

Second. Is he doing his own thinking, unprompted and uninterrupted by the teacher?

Third. Is his work so carried on that self-respect is developed rather than vanity?

Fourth. Is he learning to recognize and to love excellence of workmanship, as shown by becoming more and more critical of himself and his own achievements?

INTRODUCTION

Fifth. Is he learning to recognize good form and to avoid unsuitable decoration?

Sixth. Is he getting some training in good citizenship by working for others?

Seventh. Does the finished product represent the child's own effort, and is the workmanship good; or was the problem too difficult?

Although the models and the directions here outlined have been planned with great care, it must be understood that they are not recommended as a fixed and unalterable plan of work. Teachers should always change the methods and models in the interest of general improvement or adapt them for special needs.

It is hoped that the suggestions here given may prove of service to teachers as well as to pupils, and meet the demand of a genuine need.



WOOD OR TIMBER

A variety of native woods suited to the character of the objects made should be selected. Wood is conceded to be superior to any other manual-training material. It has, so to speak, more life than such materials as clay, paper, or metal. The material itself excites an interest in the children. The structure or grain, as well as the great variety in coloring, gives an opportunity to study nature's way of decoration. From a physiological standpoint, also, there is no material to meet the requirements quite as adequately as wood does. It gives a measured resistance to the muscles, and can be adapted to the individual strength of the worker.

The teacher should have a good knowledge of the different kinds of wood suitable for sloyd work, especially of those kinds most easily obtained in the vicinity of the school.

The various woods are recognized by their texture, color, weight, and odor. The texture is best studied in the transverse, radial, and tangential sections. By a *transverse* or *cross* section is meant a cut across the fibres of a tree or board. A *tangential* section is cut in the direction of the fibres and at a tangent to the rings of the annual layers. A *radial* section is also made in the direction of the fibres, but forms a radius of the rings. It is this last cut which gives the beautiful figures found in oak, beech, and maple, and is commonly called quartered wood.

In studying the cross section we find in the centre a column of cellular tissue called the *pith* or *medulla*, and around this centre a number of concentric rings called the *annual layers*. By counting the number of these rings we find the age of the tree. *Heartwood* is the darker and firmer part around the pith and *sapwood* is the outer, lighter, and sappy

part of the trunk. The heartwood is more fully developed, and, consequently, more durable than the sapwood. Between the bark and the last annual layer is a ring called the *Cambium*. This is in a transition state, and consists of a number of very small cells, which during spring, summer, and autumn undergo many changes in composition and form, and ultimately form a new annual ring consisting of two distinct textures known as *spring wood* and *autumn wood*. Spring wood is lighter and more porous, while autumn wood is darker and more durable. This is partly the reason for the shifting color in wood. Small lines or fibres leading from the centre to the bark are called *medullary rays* or *silver grain*. These bind together the annual layers and help in the distribution of moisture through the tree.

The best season for felling trees is during midwinter when the sap is at a standstill. By the *seasoning* of wood is meant the driving out of the sap or moisture which the wood contains. We call wood seasoned when the quantity of moisture contained coincides with that contained in the atmosphere. A fence, for example, would not need wood as well seasoned as that used for inside furniture. If too well seasoned, the wood will swell; if not sufficiently seasoned, it will shrink. We can generally tell whether wood is well seasoned by its weight. Another way of testing is by knocking on the wood, and, if it is well seasoned, it gives forth a ringing sound. Various methods of seasoning are employed. The best method is to place the wood in the open air in such a way as to permit the air to circulate freely about it. Previous to this the logs are often placed in a stream of water to draw out the sap more quickly. Another process of hastening the seasoning is by artificial means. The lumber is placed in a gradually rising temperature in a kiln, hence the name, kiln-dried wood. The rapidity with which the moisture is evaporated depends on the size and quality of the wood. Soft wood will usually dry in a kiln in four days, while hard woods take

longer, some requiring years to season. The drying must always be done gradually and carefully, or the wood may split.

Lumber stored up for sloyd work should be placed in such a way that the air will circulate freely around it, that is to say, if placed on shelves, strips of wood should be placed between the boards.

Shrinking occurs whenever the wood loses moisture. The shrinkage is least with the length of the fibres, and two or three times more in a tangential than in a radial direction.

Swelling is caused by the absorption of moisture, as a drop of water placed upon a dent in a sloyd model will readily prove.

Warping is unequal shrinking or swelling.

Winding is unequal warping caused by unevenness in grain. First-class lumber is carefully selected and well seasoned, and it is this grade which is required in sloyd.

Lumber used in sloyd is generally ordered by the square foot, with a statement of kind, quality, thickness, and approximate width of boards wanted, and whether they are to be rough or planed.

The following brief description of a few kinds of common trees and woods, with the different American and Latin names, may be of interest and help to teachers and students of Elementary Sloyd and Whittling:

White Pine, Weymouth Pine, *Pinus strobus*, is one of the tallest and most stately of our evergreen trees. It sometimes reaches a height of one hundred and twenty feet, with a diameter of three to four feet. **Found** from Newfoundland to Manitoba and along the Alleghany Mountains to Georgia. **Bark** of the trunk is lighter and smoother than in the other pines. **Leaves** or needles, from three to five inches long and grow in clusters of five. **Cones**, from four to six inches long and about one inch in diameter; cylinder-shaped and slightly curved. **Wood** is valuable timber, and when freshly cut is of a creamy-white appearance, but becomes light brown on exposure. The wood is free from knots,

straight-grained, and soft; not liable to warp and twist, and gives a clean, aromatic smell.

White Pine is excellent for sloyd work, but is expensive. White Wood and Bass Wood are less expensive, and may be used to some extent instead of Pine.

White Wood, Tulip Tree, *Liriodendron tulipifera*. The Tulip Tree reaches a height of one hundred and ninety feet, with a trunk ten feet in diameter. **Found** mostly as far south as Alabama and Georgia. Common in New England States, but not abundant. **Bark**, dark ash-color, furrowed. **Leaves**, alternate, simple, three to five inches long and wide. **Wood**, light, soft, straight-grained; heartwood light yellow or brown, and the thin sapwood nearly white.

Bass Wood, American Linden, Lime Tree, Bee Tree, *Tilia americana*. A straight-trunked tree, sixty to eighty feet high and two to four feet in diameter. **Found** from British America southwest to Virginia. **Bark**, very thick, dark brown. Inner bark very tough. Is used for mats and coarse rope. **Leaves**, about four to five inches long and from three to four inches wide. **Wood**, white, soft, and clear of knots, less valuable than White Wood, owing to its liability to crack in bending.

Sugar Maple, Hard Maple, Rock Maple, *Acer saccharinum*. A tree fifty to eighty feet high or more. **Found** from southern Canada through the Northern States. It grows in rich woods, often forming "groves." From its sap we get "maple sugar," about five to ten pounds from the average tree each season. **Bark**, light gray and smooth. **Leaves**, simple, opposite. **Wood** is white, uniform in texture, hard, strong, tough, and difficult to split. Accidental variations furnish the handsome Bird's-Eye Maple and Curled Maple.

Beech, *Fagus ferruginea*. A stately tree, about fifty to eighty feet high. **Found** in rich woods from Nova Scotia to Florida and westward to lower Mississippi basin. **Bark**, light gray and smooth. **Leaves**,

egg-shaped, three to six inches long and about half as wide. **Fruit**, a small prickly burr, splitting half-way to the base when ripe. **Wood**, hard, close-grained, light brown, uniform in color. Medullary rays, large, glossy, and dark brown.

Sweet Gum, Bilsted, *Liquidambar styraciflua*. Sweet Gum comes from the Witch-hazel family, and is a tree sixty to one hundred feet high, with a trunk two to five feet in diameter. **Found** from Connecticut to Illinois and southward. **Bark**, light brown. In the South a spicy gum comes from the bark and is used medicinally. **Leaves**, simple, alternate, five-pointed, star-shaped, from three to five inches long and three to seven inches broad. **Wood**, bright reddish-brown, sapwood nearly white, close-grained, not strong, liable to warp in drying, easy to work, takes good polish.

Red Cedar, *Juniperus virginiana*. An evergreen tree, fifteen to thirty feet high. **Found** in southern Canada and distributed throughout the United States. **Bark**, reddish brown. **Leaves**, needle-shaped, about one-fourth of an inch long and placed in pairs, sometimes in threes. **Fruit** or berries, about the size of a small pea, bluish and covered with a white powder. **Wood**, valuable, light, durable, fragrant. Heartwood dull red, sapwood white. Used almost exclusively in the making of lead pencils.

Butternut, White Walnut, *Juglans cinerea*. Common. Usually fifty to seventy feet high. **Bark**, light grayish-brown. **Leaves**, alternate, compound, fifteen to thirty inches long, with eleven to seventeen leaflets. **Fruit**, nut, rough, nearly cylindrical; one-half to two and a half inches long. Kernel sweet, but oily. **Wood**, light brown, light, soft. Coarse-grained and not strong. Takes good polish.

Black Walnut, *Juglans nigra*. This is one of the grandest and most massive trees. It reaches a height of sixty to seventy feet. Generally distributed, abundant in the middle of the Mississippi Valley. **Bark**,

dark brown. **Leaves**, alternate, compound, from one to two feet long. Fifteen to twenty-three leaflets. **Fruit**, nut, oval. About one and one-half inches in length. Kernel sweet and edible. **Wood**, dark purplish-brown, heavy, hard, close-grained, and strong. Takes a beautiful polish.

The Redwood, *Sequoia sempervirens*. The Redwood of California is a coniferous tree and belongs to a genus of which the Big Tree is the only other species now alive. Redwood forms dense forests on the west slopes of the Coast Range. It grows to a greater height than any other American tree. It reaches a height of from two hundred and twenty-five to three hundred and fifty feet, with a diameter of from ten to twenty feet. Most of the Redwood cut are from four hundred to eight hundred years old. The oldest Redwood found began life one thousand three hundred and seventy-three years ago. **Bark** is of a reddish-gray color. **Wood** is of color that shades from light cherry to dark mahogany. It is used for all kinds of finishing and construction lumber. Usually straight-grained, light, firm, yet soft. The wood is durable, easy to work, and takes a good polish. This wood is not much used in the Eastern market, owing largely to the high freight-rates in shipping.

SUPPLEMENTARY READING ON TREES FOR THE TEACHER.

"Our Native Trees," by Harriet L. Keeler, Charles Scribner's Sons, New York.

"American Woods," by Romeyn Hough, Lowville, N. Y.

"The Trees of North-Eastern America," by Charles S. Newhall.

"Timber," Bulletin No. 10, United States Department of Agriculture, Division of Forestry.

"The Redwood," Bulletin No. 38, U. S. Department of Agriculture, Bureau of Forestry.

"With the Trees," by Maud Going, comments on the trees from the standpoints of the naturalist and nature-lover, and contains legends and stories.

"A Year with Trees," by Wilson Flagg; gives brief essays on trees and their habits, and considers the tree in its relation to climate, soil, birds, insects, ornament, poetry, and fable.

"A Guide to the Trees," by Alice Lounsberry; brief descriptions of trees from the standpoint of the naturalist, with some notes of legend and history. Especially fine illustrations in color by Mrs. Ellis Rowan.

"Familiar Trees," by F. Schuyler Matthews; a naturalist's description of trees.

ELEMENTARY SLOYD AND WHITTLING

"Among Flowers and Trees with the Poets," compiled by Minnie Curtis Wait and Merton Channing Leonard. Parts III and IV of this volume are devoted to trees and shrubs—in general; trees and shrubs—specified. This book contains a rare collection of flower and tree poetry.

"In the Child's World," by Emilie Poulsson; list of tree selections for teachers is given on page 256.

SUPPLEMENTARY READING ON TREES FOR CHILDREN

The following list of books for children contains facts about trees, descriptions of trees and their habits, as well as stories, myths, and legends in prose and poetry. Most of the volumes are illustrated.

"Trees in Prose and Poetry," by Gertrude L. Stone and Grace Frichett. This book presents the tree in descriptive narrative and in legend, myth, and story.

"Book of Nature Myths," by Florence Holbrook, contains two legends: "Why the Evergreen Trees Never Lose Their Leaves" and "Why the Aspen Leaves Tremble."

"Nature Myths," by Flora J. Cooke, contains the following tree stories: "Daphne," "Fairy Story," "Philemon and Baucis," "Poplar Tree," "The Secret of Fire."

"In Mythland," by M. Helen Beckwith, contains two tree stories: "How Daphne Became a Tree"; "Philemon and Baucis."

"The Stories Mother Nature Told her Children," by Jane Andrews, contains two tree stories: "The Talk of the Trees in the Village Street," "How Quercus Alba went to Explore the Under World and What Came of It."

"The Stories of the Trees," by Mrs. Dyson, presents, in a series of talks, the natural features and habits of trees, as well as various historical facts relating to them.

"A Japanese Garland," by Florence Peltier, gives the Japanese symbolism of tree and flower.

"The Story Hour," by K. D. Wiggin and Nora A. Smith, contains "A Story of the Forest," a charming Xmas story.

"Stories," by Hans C. Andersen, contains "The Last Dream of the Old Oak," a symbolic tree story in Andersen's best vein.

"In the Child's World," by Emilie Poulsson, gives talks and poems on trees, pages 253-262. In this volume a list of tree selections is given for teacher and children. Page 30 contains a charming story, "An Old-Fashioned Rhyme, 'This Is the Tree of the Forest.'"

"Nature in Verse," compiled by Mary I. Lovejoy. "Three Trees," page 288; "The Little Pine Tree," page 285; "The Tree," by Björnson, page 26; "The Tree," by Jones Very, page 27.

"Open Sesame," vol. 1. Edited by B. W. Bellamy and M. D. Goodwin. "To the Fir Tree," from the German, page 121.

"All the Year Round," Part II. "Winter," compiled by Frances L. Strong; "The Little Fir Trees," page 56; by Evaleen Stein; "The Fir Tree," adapted from Andersen, page 50; "The Discontented Pine," by C. S. Bumstead, page 46; "The Evergreen," page 42; "The Pine," page 44.

"Golden Numbers," compiled by Kate D. Wiggin and Nora A. Smith; "The Planting of the Apple Tree," page 59, Bryant; "Mine Host of the Golden Apple," page 64, Thomas Westwood; "A Young Fir Tree," D. G. Rossetti, page 65; "The Showing of the Pines," page 66, by T. W. Higginson.

TOOLS AND IMPLEMENTS FOR ELEMENTARY SLOYD

TOOLS are instruments by which the hands give material expression to thought. Consequently, such tools should be selected as will best promote physical and mental growth.

The tools should be of the best quality; although the first cost may seem large it is cheaper in the long run. While tools of regular size are best in ordinary sloyd, smaller ones should be selected for young children. Toy tools, or those found in children's tool-boxes, are generally of poor quality and not to be recommended. To avoid many failures, the tools should not only be of the right kind, but properly sharpened and adjusted. It must be remembered that good tools must be kept in good condition.

To teach habits of order and neatness, Benches and Tools must be kept in perfect order. The rule should be: "A place for everything and everything in its place."

In order to simplify and economize the outfit for Elementary Sloyd, it is thought best that only one kind of Plane be used, and that such tools as Marking Gauges, Auger Bits, Chisels, and Carving Tools be excluded.

The following illustrations, with explanations of Benches and Tools used in Elementary Sloyd, may be of service:



Fig. 1.

SINGLE ADJUSTABLE SLOYD BENCH

The Bench here illustrated was designed by the author in 1889. It differs from the ordinary carpenter's bench in that it is adjustable to suit the height of the worker. Instead of the common iron bench-stop for planing, it has an end vise and holes for wooden stops or pins along the bench-top. These hold the wood securely at both ends while planing bevels, cylinders, etc., and in modelling different forms. A single stop may be used for straight-surface planing. As a general rule, such work as requires strong muscular effort should be done in the direction of the length of the bench, and any hammering or pounding should be done over the upright supports. The top is glued up from four or more

strips of maple to prevent warping, and the lower part is fastened together by keyed joints. Vises and screws are made of maple. Wood screws are considered better, although iron screws will be furnished if desired.

Two sizes of this Bench are made. The smaller size is designated by the manufacturers as No. 6, and is large enough for any work which may be done by children in grammar grades.

The extreme length and width of Bench No. 6 is forty-two by twenty-eight inches, and Bench No. 5 is one foot longer. The height may be adjusted from thirty to thirty-three inches, which is suitable for pupils from eight to twelve years.

The Benches should be placed in such a way as to have the light come from the left and back as the worker faces the Bench.

The distance between Benches should not be less than two feet. Benches should be securely fastened to the floor by means of a leg screw at each end.

Tools most frequently used are kept on the bench, in racks, and on hooks, all within sight. This arrangement allows the teacher to observe readily the order in which the tools are kept, and in this respect it is superior to the use of drawers and lockers. The back-board with the tool-rack may be lowered, if desired, so as to make it level with the bench-top. Great care should be taken not to injure the bench-top. To keep it in good condition it should be rubbed down occasionally with raw linseed oil.

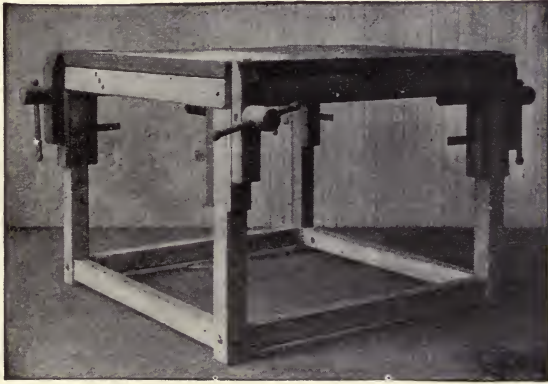

Fig. 2.

WORK TABLE FOR FOUR PUPILS

This Table is designed for use in places where the regular single sloyd bench is thought too expensive. It is a strong Table. Size of top, thirty-six by thirty-six inches; height, thirty inches; four vises attached. This accomodates four pupils.

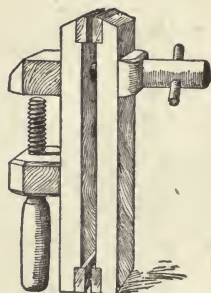

Fig. 3.

CLAMP VISE

In order further to lessen the expense of an outfit, Clamp Vises may be obtained and fastened to a horizontal board or strong table. This clamp can be used only while doing light work.

Tools illustrated in the order in which they are used :

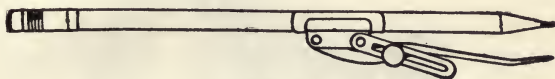

Fig. 4.

NEW PENCIL COMPASSES

Lead pencil No. 3 is recommended for wood-work. Keep point of pencil about one inch long. In sharpening, remove wood with knife and point the lead on No. 1 sandpaper.

In using Compasses adjust point to equal length with pencil point and hold at top between thumb and forefinger.

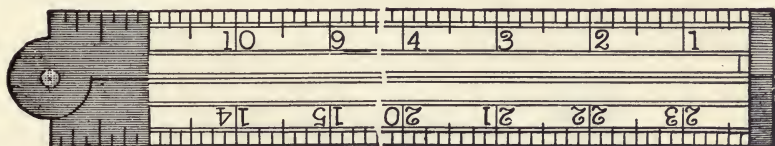

Fig. 5.

RULE (BOXWOOD, 2 FT. 2 FOLD)

Hold Rule on edge in measuring and marking distances, but lay it flat on material in drawing lines.

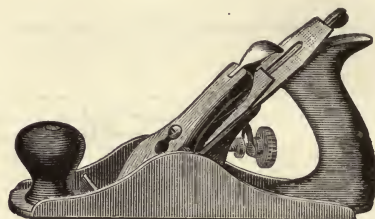

Fig. 6.

IRON SMOOTHING-PLANE, 8 IN. X 1 3-4 IN. CUTTER (BAILEY)

Set Cap-iron about one-sixteenth of an inch from edge of Plane-iron. Adjust plane iron for coarse or fine shavings by using the thumb on the brass adjusting-nut (thumb-screw) while resting the "heel" on the bench. Move lateral adjustment so as to make edge of Plane-iron appear even.

Grasp the plane by the handle and press and guide firmly with the other hand on the "knob," taking special care not to tip the plane at the ends of the wood.

When planing with right hand place left foot forward in direction of working force. Keep legs and back straight, but not in a constrained position.

When end planing on bench hook is to be done, set cap back about one-eighth of an inch, and hold side of plane firmly on the bench close to bench hook.

If plane clogs with shavings remove iron to clean it. Never take out shavings with knife or any other tool. In grinding or whetting plane-iron keep cutting-edge and bevel straight, rounding the corners a little.

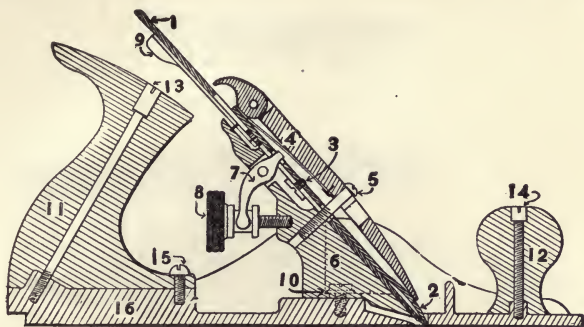

Fig. 7.

LIST OF PARTS OF BAILEY PLANE

- | | |
|---|----------------------------|
| 1. Plane-Iron. | 9. Lateral Adjustment. |
| 2. Plane-Iron Cap. | 10. Frog Screw. |
| 3. Plane-Iron Screw. | 11. Handle. |
| 4. Cap. | 12. Knob. |
| 5. Cap Screw. | 13. Handle "Bolt and Nut." |
| 6. Frog. | 14. Knob "Bolt and Nut." |
| 7. "Y" Adjustment. | 15. Handle Screw. |
| 8. Brass Adjusting-Nut or
Thumb-screw. | 16. Bottom. |



Fig. 8.

BENCH-HOOK, OAK

Examine Bench-hook with try square to see if it is true. If not, correct it before using. Hook it over edge of bench or fasten in vise flat and firmly.



Fig. 9.

SPLITTING SAW (SPECIAL, 14 IN. 10 PTS.)

This Saw is used for sawing with the grain of the wood, or in the direction in which the wood splits. The cutting-off or cross-cut Saw is used for cutting across the fibres of the wood. For shape of different teeth see Fig. 10.

The Saw should be grasped firmly with one hand on handle and the other resting on the wood. Place the feet in proper position, with the advance foot in the direction of the working force, as in planing. The saw must not be pressed down upon the wood, but moved horizontally with long, light, and even strokes.

NOTE: In the vigorous exercises of planing and sawing, it is of the utmost importance that correct positions be maintained, in order to avoid fatigue and possible deformity, and to insure better work. For the same reasons exercises in planing, sawing, and boring may be done alternately by right and left hand.



Splitting 10 pts. to inch.



Cutting off 12 pts. to inch.

Fig. 10.

SAW TEETH

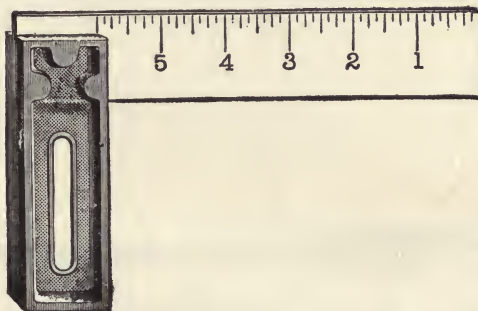

Fig. 11.

IRON HANDLE TRY SQUARE

This tool consists of blade and beam or handle, and is used for testing surfaces which should be at right angles to each other, and for squaring lines across the wood. In using hold the handle firmly up to the planed face (working face) of the wood. Do not hammer or pry with this tool, as it makes it inaccurate for use.

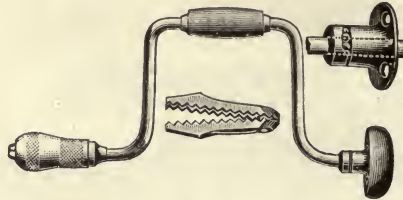

Fig. 12.

BIT BRACE (BARBER, 4 IN.)

Fasten the bit securely in the jaws. When using hold the head of the brace in the left hand and turn crank to right.



Fig. 13.

DRILL BIT, WITH BIT POINT

This bit is used for boring holes for nails, screws, etc. This tool has a triangular point to insure its boring in the right place. Be careful to hold bit at right angles to wood and use light, even pressure. Boring in a horizontal direction is preferable in Elementary Sloyd.



Fig. 14.

CENTRE BIT

This tool is useful for boring in thin wood, as it does not split it. Bore only until the centre or spur comes through, then turn wood and finish.

The bit should be sharpened with a fine file and slip stone and tried on waste piece of wood before using.



Fig. 15.

COUNTERSINK (ROSE)

This tool is used with brace to sink holes for screw heads.

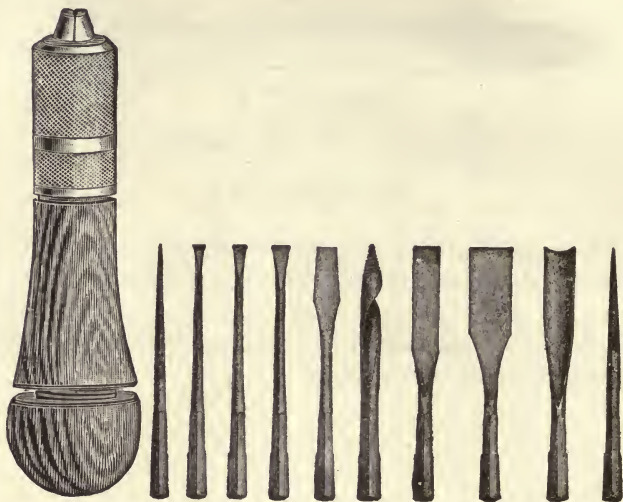

Fig. 16.

TOOL HANDLE WITH 20 AWLS AND TOOLS

The cuts of this tool illustrate the various uses for which it is adapted.

In using the brad-awl place the edge across the grain of the wood and repeatedly turn the hand half-way around and back with slight pressure.



Fig. 17.

BACK SAW, 10 INCH

This is a saw with very fine teeth and makes a smooth cut. In Elementary Sloyd it may be used in place of the cross-cut saw.

The thin blade is strengthened by an iron "back," from which the saw derives its name.

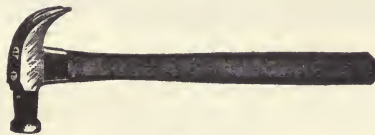

Fig. 18.

HAMMER, A. E. B. F. (7 OZ.)

Hold the hammer near the end of handle and strike squarely on the nail head. When withdrawing nails with the claw of the hammer place a block of wood under the head so as not to injure the planed surface.



Fig. 19.

NAIL SET (HOLLOW POINT)

The nail set is used for driving nails below the surface of the wood. The hole left in the wood after setting the nail may be partly closed by applying a drop of water, but no putty or plug should be used. The nail set with the hollow point is preferable to the one with a flat point, as it does not slip.



Fig. 20.

HALF ROUND FILE, 8 IN.

A file should never be used when an edge tool can accomplish the work.

In smoothing a surface to a line hold the handle of the file with the right hand and place the left hand at the end of the file, with the thumb on the top. If the file becomes clogged, use a file card or place in lukewarm water. After drying clean with a brush.

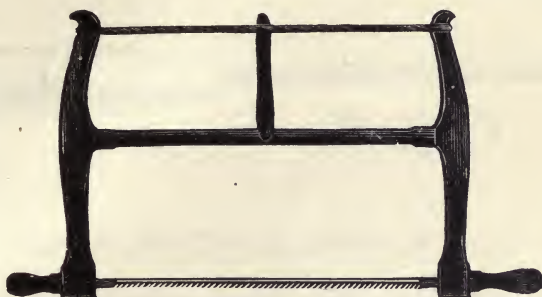

Fig. 21.

TURNING SAW (8 IN., 1-8 IN. BLADE, 12 PTS.)

Before using the turning saw, see that the blade is perfectly straight and tight. Grasp the saw with both hands at the handle where the teeth of the saw point away from you and move it squarely through the wood with long, light, steady strokes. By loosening the cord and taking out one end of the blade it may be used for interior cutting, such as picture-frames, etc.



Fig. 22.

IRON SPOKE-SHAVE

The spoke-shave is a most valuable tool because both hands are equally used. Originally it was used in making spokes, hence its name. It can be used either from you or towards you, but always on curved surfaces and should not be used where the plane can be used equally well. Care must be taken to cut always with the grain of the wood.

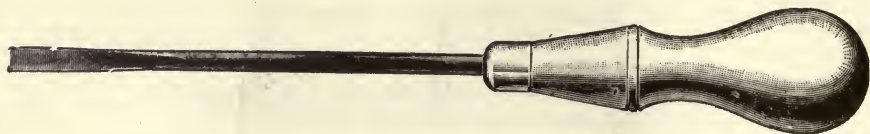

Fig. 23.

SCREW-DRIVER, 3-IN. ROUND

See that the end of the screw-driver is perfectly flat and that the narrow sides are as nearly parallel as possible. In using hold it firmly and straight in the groove of the screw head, so as not to mar the screw head.



Fig. 24.

SLOYD KNIFE, 3-IN. BLADE

The knife is not recommended for Elementary Sloyd, as children may not have sufficient strength for its use. It is a useful tool, however, in places where no other can be used conveniently. The knife recommended has a blade three inches long, with a straight bevel on both sides and a four-inch handle. The tang of the blade is riveted through the handle so as to make it more secure.



Fig. 25.

COMPASS SAW (IRON HANDLE)

The compass or keyhole saw is used to saw interior parts, such as keyholes, picture-frames, etc.



Fig. 26.

DRAWING KNIFE

This tool, like the spoke-shave, can be used with both hands. It is used for heavy work in cutting off rough edges, branches and bark, rounding poles, handles, etc. In using the drawing knife the wood should be fastened in the vise.



Fig. 27

FLAT FILE, SMOOTH, 5 IN.

This file is used for sharpening bits, cap irons, etc., previous to the use of the slip stone.



Fig. 28.

SLIP STONE

The slip stone is used for whetting the inside of gouges, bits, etc.



Fig. 29.

SHARPENING OUTFIT

The oil stone should be kept clean and straight. If uneven it is difficult to sharpen the tools properly.

To make the oil stone level fasten a half sheet of No. 1 sandpaper on a board, apply a little water, and rub until true.

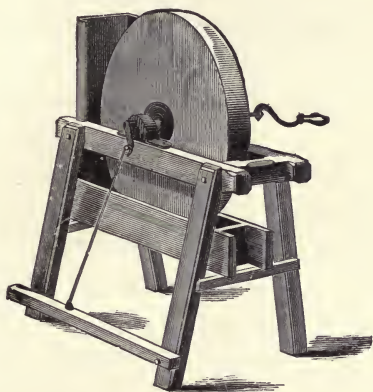

Fig. 30.

GRINDSTONE, 18-IN. DIAMETER

Keep water in the trough only when grinding. In sharpening edge tools turn the stone toward the edge of the tool. Hold the tool steadily and firmly and give a lateral motion across the stone to prevent irregular wearing.

Aim to make a flat bevel.

For the illustration of tools, the author is indebted to Messrs. Chandler & Barber, Boston, Mass.

ELEMENTARY SLOYD AND WHITTLING

LIST OF TOOLS AND MATERIAL FOR FOUR PUPILS

- 1 Work Table for four pupils, \$10.
- Single Adjustable Sloyd Bench, \$9.
- 4 New Pencil Compasses, with Lead Pencil No. 3.
- 4 Rules (boxwood, 2 foot, 2 fold).
- 4 Iron Smoothing Planes, 8 x 1 $\frac{3}{4}$ inch cutter (Bailey).
- 4 Bench Hooks.
- 2 Splitting Saws (special 14 inches, 10 points).
- 4 Try Squares, (6 inches).
- 2 Bit Braces (Barber, 4 inches).
- 2 Drill Bits, with bit points each 3-16 and $\frac{1}{4}$ inch.
- 2 Centre Bits, each, $\frac{3}{4}$, $\frac{5}{8}$, $\frac{1}{2}$, $\frac{3}{8}$, and $\frac{1}{4}$ inch.
- 1 Countersink (Rose).
- 1 Tool Handle (20 awls and tools).
- 2 Back Saws, (10 inches).
- 1 Hammer, A. E. B. F. (7 ounces).
- 1 Nail Set (hollow point).
- 2 Half Round Files (8 inches).
- 2 Turning Saws (8 inches, $\frac{1}{8}$ -inch blade, 12 points).
- 2 Iron Spoke-shaves.
- 1 Screw-driver (3 inches round).
- 2 Sloyd Knives (3-inch blade).
- 1 Cross-cut Saw (special, 14 inches).
- 1 Compass Saw (iron handle).
- Total cost for one pupil with single Adjustable Bench, \$20.
- Total cost for four pupils with table for four, \$33.19.

ELEMENTARY SLOYD AND WHITTLING

AMOUNT OF WOOD FOR THE FIRST TWELVE MODELS
FOR FOUR PUPILS

The wood should be of the best quality, kiln-dried and planed.

4 square feet $\frac{1}{4}$ -inch Whitewood.

7 " " $\frac{3}{8}$ - " "

3 " " $\frac{1}{2}$ - " "

10 " " $\frac{5}{8}$ - " "

$\frac{1}{4}$ " foot $\frac{7}{8}$ - " "

1 " " $\frac{5}{8}$ - " White Pine.

6 " feet $\frac{1}{4}$ - " Sweet Gum or Black Walnut.

$1\frac{1}{2}$ " " $\frac{3}{8}$ - " " " " " "

4 Maple Dowels $\frac{5}{8}$ inch.

MISCELLANEOUS

Wire Brads $\frac{1}{2}$ inch, No 19.

" " 1 " No 17.

" " $1\frac{1}{2}$ inches, No. 15.

Screws $\frac{3}{8}$ inch, No. 1.

" 1 " No. 8.

" $1\frac{1}{4}$ inches, No. 10 (Round Head).

" 2 " No. 14 (Round Head, Blue).

$\frac{1}{2}$ Pint Le Page's Liquid Glue.

Sandpaper Nos. 1 and 0.

Flat File. (Smooth, 5 inch.)

Slip Stone.

Sharpening Outfit (India Oil Stone, Oil Can, and Cotton Waste,
mounted on wood).

Grindstone 18 inches diameter.



ELEMENTARY SLOYD

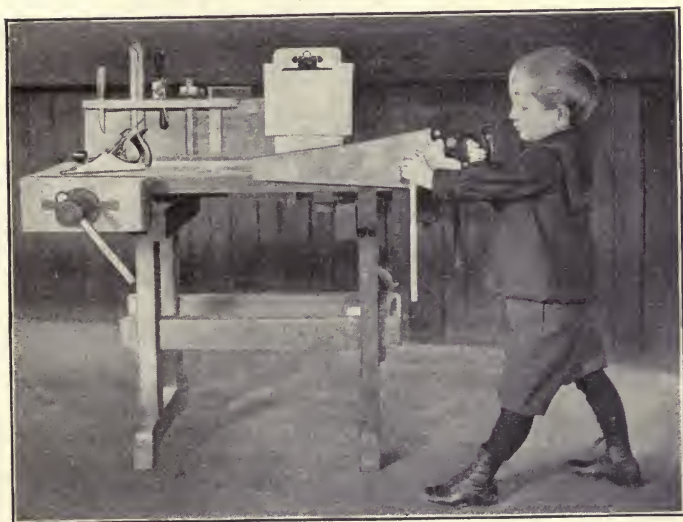



DIRECTIONS FOR ELEMENTARY SLOYD



Fig. 31.

1.—PENCIL SHARPENER

Whitewood. $\frac{1}{4}$ inch.

TOOLS

Pencil, Rule, Plane, Bench Hook.

DIRECTIONS

Wood prepared $6\frac{1}{8} \times 1\frac{3}{4}$ inches.

1. Plane one side straight.
2. Measure width, draw line, and plane.
3. Plane one end in bench hook.
4. Measure length and plane.
5. Sandpaper with block, rounding corners.
6. Cut sandpaper, No. 1, and glue to wood.

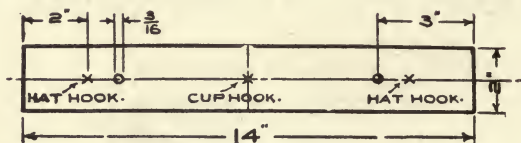

Fig. 32.

2.—HAT AND BRUSH RACK

White Pine. $\frac{1}{8}$ inch.

NEW TOOLS

Splitting Saw, Try Square, Bit Brace, and Drill Bit.

DIRECTIONS

Wood prepared in length $14\frac{1}{2}$ inches.

1. Plane one side straight and square.
2. Measure width, draw line, saw $\frac{1}{8}$ inch from it, and plane to line.
3. See 3 and 4 in Model No. 1.
4. Draw centre line, measure for hooks and holes, and bore holes.
5. See 5 in Model No. 1.
6. Put in hooks, two wire hooks for ends and one cup hook for centre.

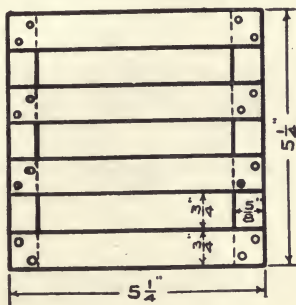

Fig. 33.

3.—STAND

Whitewood. $\frac{1}{4}$ and $\frac{5}{8}$ inch.

NEW TOOLS

Back Saw, Hammer, and Nail Set.

DIRECTIONS

Wood for supports $11 \times \frac{5}{8}$ inch, for slats $11 \times \frac{1}{4}$ inch.

1. Saw for supports 1 inch wide and plane square to required dimensions.
2. Find centre, saw with back saw.
3. See 3 and 4, Model No. 1.
4. Saw pieces for slats 1 inch wide, and plane and saw as for supports.
5. Sandpaper, find points for nails, drive and set nails.

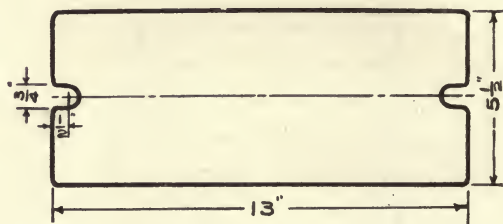

Fig. 34.

4.—SWING BOARD

Whitewood. $\frac{5}{8}$ inch.

NEW TOOLS

Centre Bit $\frac{3}{4}$ inch, half-round File 8 inches.

DIRECTIONS

Wood prepared in length $13\frac{1}{4}$ inches.

1. See 1 and 2 in Model No. 2.
2. Fasten wood firmly in the vise and plane one end square. (In order not to split corners, always plane from corners toward centre.)
3. Measure length, draw line, and plane to it.
4. Find points for centres of holes, and bore (horizontally) from both sides.
5. Draw lines with try square, finish with back saw, file, and sandpaper.

NOTE: See that centre bit is well sharpened with file and slip stone and tried before using.

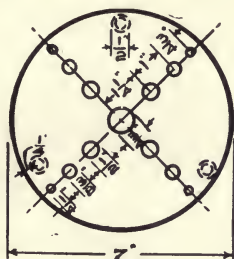

Fig. 35.

5.—TEAPOT STAND

Whitewood. $\frac{3}{8}$ inch.

NEW TOOLS

Pencil Compasses, Turning Saw, Spoke-shave, Screw-driver, $\frac{1}{2}$ -inch.
Centre Bit with lip filed away is used in making the feet.

DIRECTIONS

Wood prepared $7\frac{1}{2}$ x $7\frac{1}{2}$ inches.

1. Draw one diagonal. Erect perpendicular at centre and draw circle.
2. Fasten wood firmly in vise, keeping grain of wood nearly in a vertical position to avoid splitting.
3. Saw $\frac{1}{8}$ inch outside of circle, holding saw firmly with both hands at handle end of blade. Care should be taken to keep blade at right angles to surface of wood.
4. Spoke-shave to line, always using the tool with the grain of the wood.
5. Locate centres for holes and bore.
6. Sandpaper, make feet of $\frac{1}{4}$ -inch wood, and fasten with $\frac{1}{2}$ -inch screws.

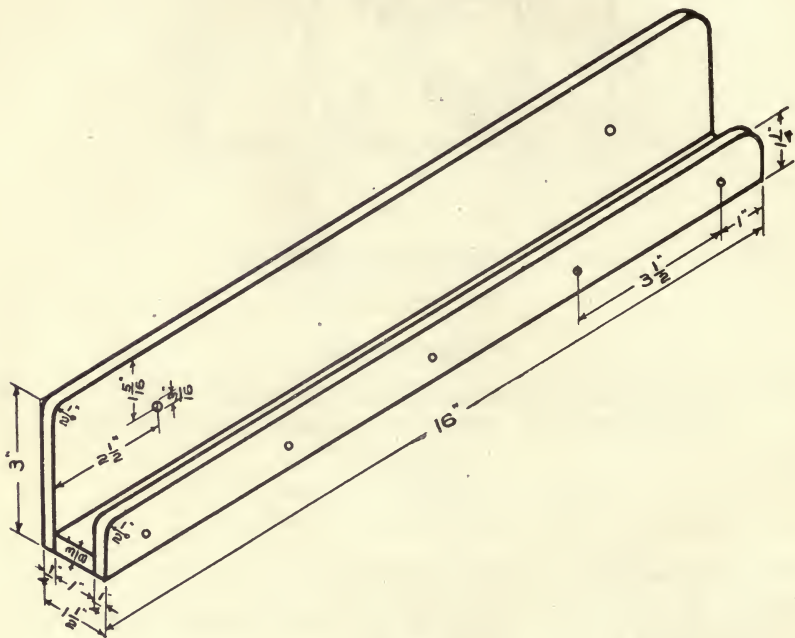

Fig. 36.

6.—SHELF FOR PHOTOGRAPHS

Whitewood. $\frac{1}{4}$ and $\frac{1}{2}$ inch.

NEW TOOLS

Cross-cut Saw and Knife.

DIRECTIONS

1. Let pupil estimate the proper amount of wood.
2. Explain and illustrate to children the difference between cross-cut and splitting saws.
3. Saw with cross-cut and splitting saws.
4. Plane pieces to required dimensions.
5. Draw arcs with compasses, cut to line with knife, and finish with file.
6. Locate points for holes and nails.
7. Bore holes, sandpaper, nail, and set nails.

NOTE: Simple decoration, such as punching, veining, or coloring, may be used on front of shelf at the discretion of the teacher.

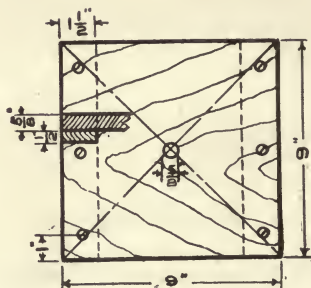

Fig. 37.

7.—RING TOSS

Whitewood. $\frac{5}{8}$ and $\frac{7}{8}$ inch, $\frac{5}{8}$ -inch dowel.

NEW TOOL

Countersink.

DIRECTIONS

See 1, 3, and 4 in Model No. 6.

1. If a bevel is desired, draw lines and plane.
2. Locate holes for screws and for dowel.
3. Bore with centre bit and drill bit.
4. Countersink holes for screws, sandpaper, and fasten cleats to board across the grain of the wood.
5. Fit and glue dowel.

NOTE: The rings may be made of rope, rattan, or wire wound with raffia, or bought ready for use.

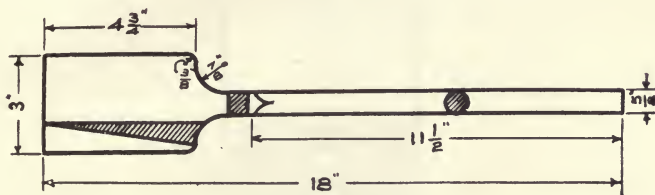

Fig. 38.

8.—SPADE

Whitewood. Thickness, $\frac{3}{8}$ inch.

DIRECTIONS

1. See 1, 3, and 4 in Model No. 6.
2. Measure and draw on wood straight lines and arcs for handle and blade.
3. Bore holes and saw with splitting saw and back saw.
4. Finish to lines with knife and spoke-shave.
5. Draw oblique lines on sides of blade, and plane.
6. Round handle (making it first octagonal) with spoke-shave, finish with file, and sandpaper.

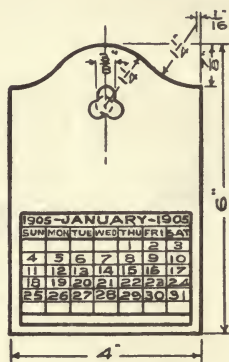

Fig. 39.

9.—CALENDAR BACK

Sweet Gum or Black Walnut. $\frac{1}{4}$ inch.

DIRECTIONS

1. Prepare wood 7 inches long, and plane to correct width.
2. Draw centre line and construction for top.
3. Finish with turning saw, knife, and file.
4. Bore holes with $\frac{3}{8}$ -inch centre bit, beginning with lower left-hand hole.
5. Mark length, saw, and plane.
6. Finish with sandpaper and mount calendar.

NOTE: This back may also be used in constructing a match-safe.

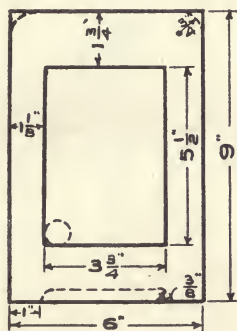

Fig. 40.

10.—FRAME

Sweet Gum or Black Walnut. $\frac{1}{8}$ inch.

NEW TOOL

Compass Saw.

DIRECTIONS

1. Prepare oblong.
2. Draw lines for opening.
3. Place centres for $\frac{3}{4}$ -inch holes at corners and bore.
4. Use compass saw, and saw close to line.
5. Finish with knife, file, and sandpaper.

NOTE: Size of frame according to the picture suggested by the children.
Cardboard may be used for the back. The frame may be finished to dotted lines if desired.

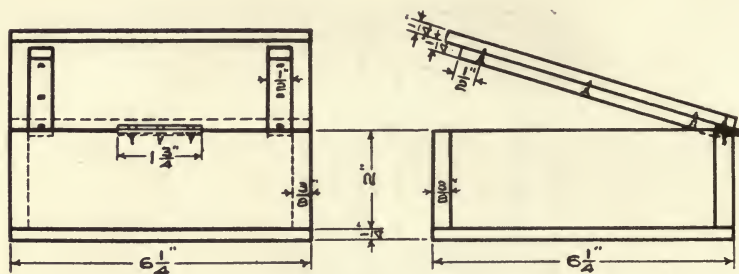

Fig. 41.

11.—HANDKERCHIEF BOX

Sweet Gum or Black Walnut. $\frac{3}{8}$ and $\frac{1}{4}$ inch,

DIRECTIONS

1. Prepare sides in one piece and finish to required dimensions.
2. Sandpaper inside and nail, using 1-inch brads.
3. Prepare cover and bottom in one piece and finish to required dimensions.
4. Sandpaper bottom and nail.
5. Prepare cleats and screw to cover.
6. Fit hinges ($1\frac{1}{2}$ inch narrow) and sink to proper depth on box only, screw hinge to box, and then to cover. A simple fastener may be attached.

NOTE: Appropriate decorations, such as simple carving, burning, or coloring, may be applied on Models 9, 10, and 11.

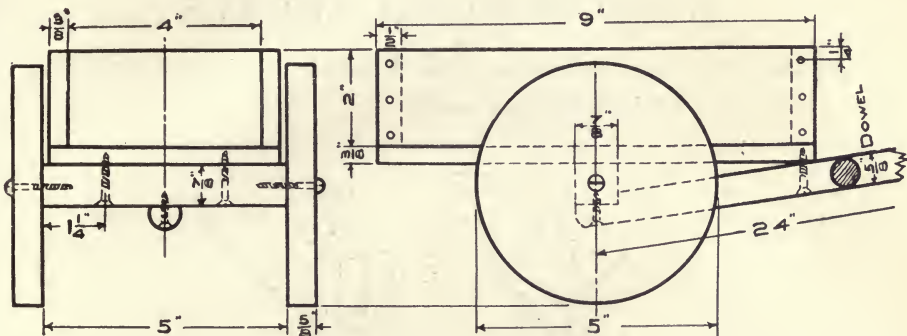

Fig. 42.

12.—CART

Whitewood. $\frac{1}{2}$, $\frac{3}{8}$, and $\frac{7}{8}$ inch. Maple Dowel $\frac{5}{8}$ x 24 inches.

DIRECTIONS

1. Prepare sides and bottom in one piece, and the ends in similar manner.
2. Finish separate parts and nail box together, using $1\frac{1}{4}$ -inch brads for sides and 1-inch brads for bottom.
3. Prepare pieces for wheels and finish with turning saw, spoke-shave, and file.
4. Prepare axle and use $\frac{5}{8}$ -inch dowel for handle.
5. Bore holes in sides of axle, in handle, and wheels, and fasten screws in same order. Use round-head blue screws (2 inch No. 14) for wheels, and flat-head screws ($1\frac{1}{8}$ inch No. 10) for axle and handle.

SUPPLEMENTARY MODELS

By supplementary models is meant a variety of objects containing given exercises to suit individual needs.

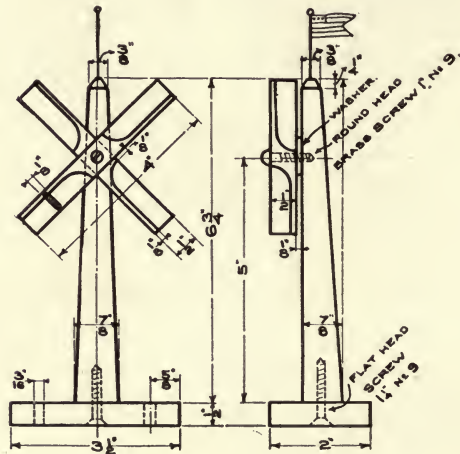

Fig. 43.

TOY WINDMILL

White Pine. $\frac{7}{8}$ and $\frac{1}{4}$ inch.

DIRECTIONS

1. Make base according to drawing.
2. Make upright support $6\frac{3}{4} \times \frac{1}{4}$ inches square.
3. Plane one end square in bench hook.

4. Taper with plane on three sides to $\frac{3}{8}$ -inch square at top.
5. Make "wings" in one length $8\frac{1}{4} \times \frac{1}{2}$ inch square.
6. Measure, square lines, cut in halves, and plane ends in bench hook to required length.
7. Measure, square lines on three sides of each piece, for halved together joint.
8. Make joint with back saw and knife, taking care to fit it tight and put together.
9. Draw one diagonal at each end in opposite directions.
10. Measure and draw curved and straight lines on both sides of each "wing" according to drawing.
11. Take joint apart and finish "wings" with knife and sandpaper.
12. Press joint together and bore holes through it and the base with $\frac{3}{16}$ -inch drill bit.
13. Make a round washer of wood $\frac{1}{2} \times \frac{1}{8}$ inch.
14. Sandpaper, insert washer, and screw parts together.
15. Insert a wire at top with a light flag which will indicate direction of the wind. Fasten base in a windy place with two screws and turn upright support according to the direction of the wind.

NOTE: A more complicated windmill which would set in motion some mechanical apparatus may be constructed.

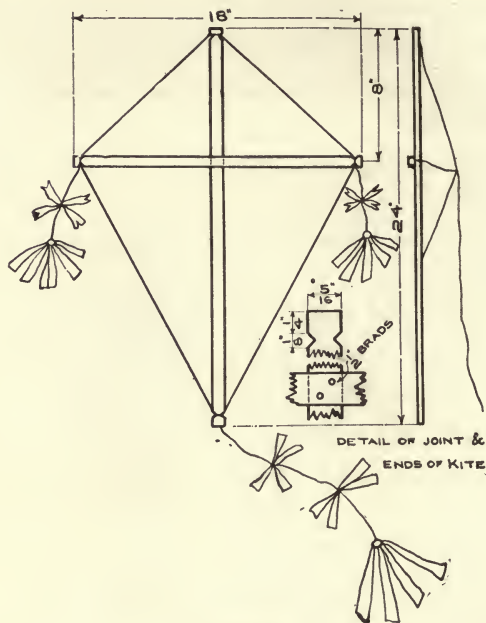

Fig. 44.

KITE

Whitewood. $\frac{1}{4}$ inch.

DIRECTIONS

1. Prepare with saw and plane two strips of wood, one $24 \times \frac{5}{16}$ inches and the other $18 \times \frac{5}{16}$ inches.
2. Cut notches at ends with knife according to drawing.
3. Measure and join pieces together by means of two $\frac{1}{2}$ -inch brads.

4. Sink brads with nail-set, holding the wood on a piece of metal, and strengthen joint by winding and tying a string crosswise around.
5. Use light but strong twine around the kite, tying it securely at each end.
6. Cover with light paper or cambric by folding and pasting or gluing it around the string.
7. Fasten a piece of twine about a foot long at each side, and cut and tie paper wings to it.
8. Make tail about three times as long as length of kite and fasten light paper wings on it about 8 inches apart.
9. Fasten the end of a ball or spool of strong twine to kite, according to drawing, and in flying use a reel to wind it on.

NOTE: Different sizes and shapes of kites may be made, but the one described above will prove to be simple and to fly well.

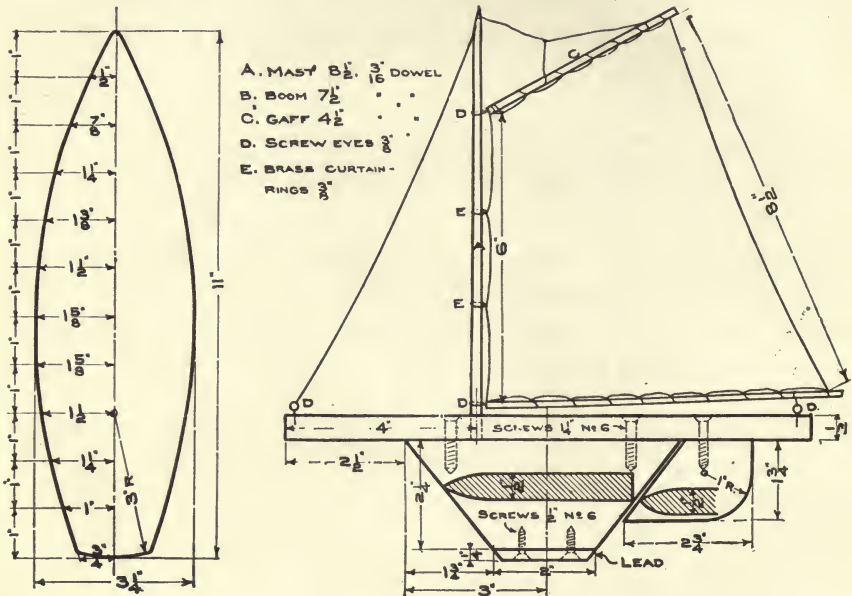

Fig. 45.

TOY BOAT

White Pine. $\frac{1}{2}$ inch.

DIRECTIONS

1. Prepare wood $11\frac{1}{2} \times 3\frac{1}{2}$ inches.
2. Plane one side straight.
3. Draw centre line parallel to planed side.
4. Divide distances of length and square lines across.

5. Measure and mark distances of width and connect points with a free-hand curve.
6. Draw arc at end with compass.
7. Cut to lines with turning saw and finish with spoke-shave and knife.
8. Make keel and rudder according to drawing.
9. Fasten keel and rudder with screws.
10. Prepare lead for keel and fasten with screws.
11. Use $\frac{3}{16}$ -inch maple dowel for mast, boom, and gaff.
12. Make sail and rig according to drawing.
13. Try boat in bath-tub to see if it balances.

NOTE: If children have the requisite skill, use thicker wood for hull and hollow it out with gouge and shape it outside with spoke-shave. Various sizes may be made.

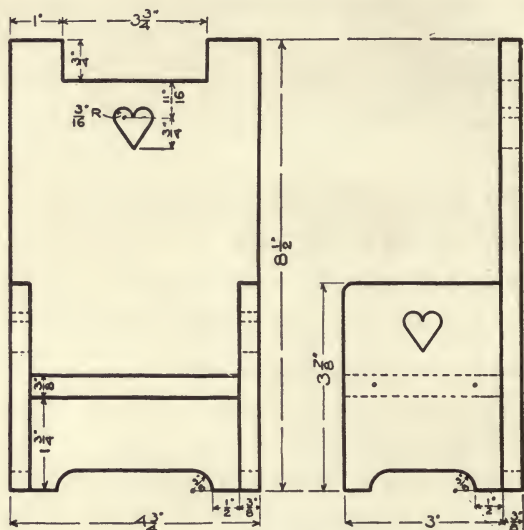

Fig. 46.

DOLL'S CHAIR

Whitewood. $\frac{3}{8}$ inch.

DIRECTIONS

1. Prepare an oblong for back according to the drawing.
2. Saw out side pieces and seat in one length and plane width.
3. Mark length of each piece according to drawing; saw and plane ends.
4. Construct back and side pieces and finish with back saw, turning saw, knife, and file.
5. Mark out heart-shaped holes and finish with $\frac{3}{8}$ -inch centre bit, compass, saw, and file.
6. Sandpaper.
7. Locate places for brads and nail parts together.

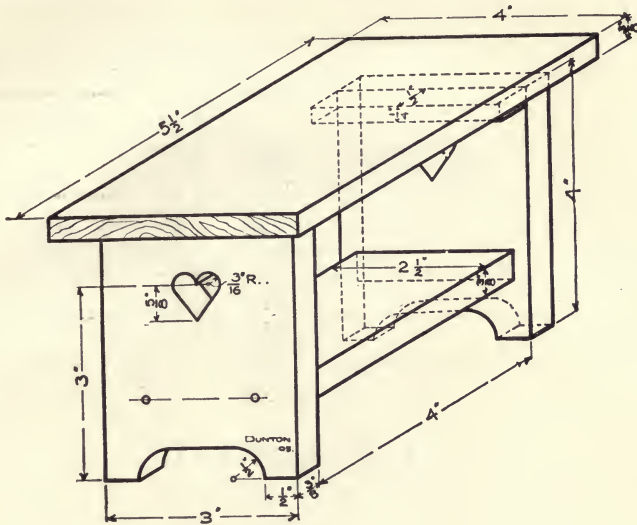

Fig. 47.

DOLL'S TABLE

Whitewood. $\frac{3}{8}$ inch.

DIRECTIONS

1. Mark and cut two legs in one length and plane width.
2. Mark length of each piece, saw, and plane.
3. Make top.
4. Prepare shelf and two cleats according to drawing.
5. Construct feet and heart-shaped holes. (See Chair, 4, 5, 6, and 7.)

NOTE: A child's chair and table may be made by using $\frac{3}{4}$ -inch wood and enlarging the dimensions about three times.

In this case $1\frac{1}{2}$ -inch No. 9 screws should be used for fastening parts together.

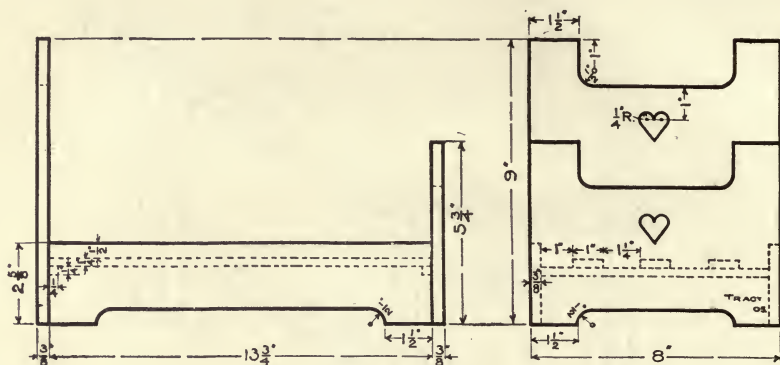

Fig. 48.

DOLL'S BEDSTEAD

Whitewood. $\frac{3}{8}$ and $\frac{1}{4}$ inch.

DIRECTIONS

1. Make the two uprights in one length, plane narrow sides.
2. Mark length, saw, and plane.
3. Make the two side pieces in one width, plane narrow sides and ends, mark width, cut apart, and plane.
4. Construct shape of uprights and sides according to drawing.
5. Finish top of uprights, using 1-inch centre bit at round corners.
6. Construct feet and heart-shaped holes. (See Chair 4, 5, 6, and 7.)
7. Mark out the strips for the bottom and the cleats in one piece 15 x 4 x $\frac{1}{4}$ inch.
8. Mark and cut pieces to proper dimensions.
9. Sandpaper and fasten parts together.

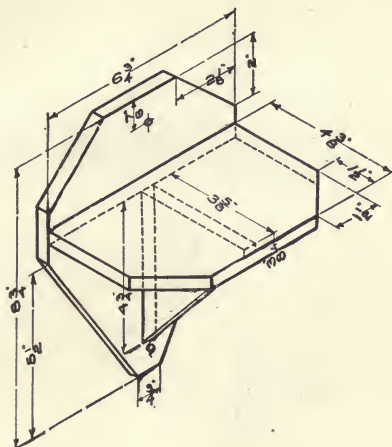

Fig. 49.

SHELF

Whitewood. $\frac{3}{8}$ inch.

DIRECTIONS

1. Construct the parts in detail upon paper or blackboard.
2. Let pupil estimate amount of wood required.
3. Take greatest length of parts in the direction of the grain.
4. Construct back, shelf, and bracket according to drawing.
5. Saw and plane parts to given dimensions.
6. Bore holes at top and bottom of back with $\frac{3}{16}$ -inch drill bit.
7. Sandpaper parts.
8. Space places for brads or screws and fasten parts together.

NOTE: If screws are preferred, use $\frac{3}{4}$ -inch No. 6. The shelf may be stained and polished.

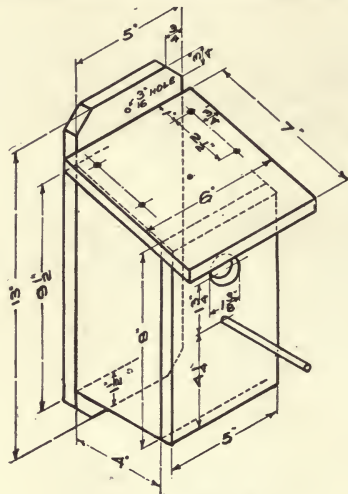

Fig. 50.

BIRD HOUSE

Whitewood. $\frac{1}{2}$ inch.

DIRECTIONS

1. See 1 in model Shelf. Fig. 49.
2. Estimate wood for back and front in one piece and sides and bottom in one.
3. Plane required width of these two pieces.
4. Measure out according to drawing and cut lengths. Plane ends without bench hook.
5. Prepare top.
6. Bore holes for entrance and for $\frac{1}{2}$ -inch dowel.
7. Bore four $\frac{1}{4}$ -inch holes through bottom, 1 inch from sides, for drainage.
8. Nail sides together with $1\frac{1}{2}$ -inch brads.
9. Fit bottom and top. Nail bottom and fasten top by round-head blued screws $1\frac{1}{4}$ inch No. 8.
10. Insert a dowel $6 \times \frac{1}{2}$ inch.

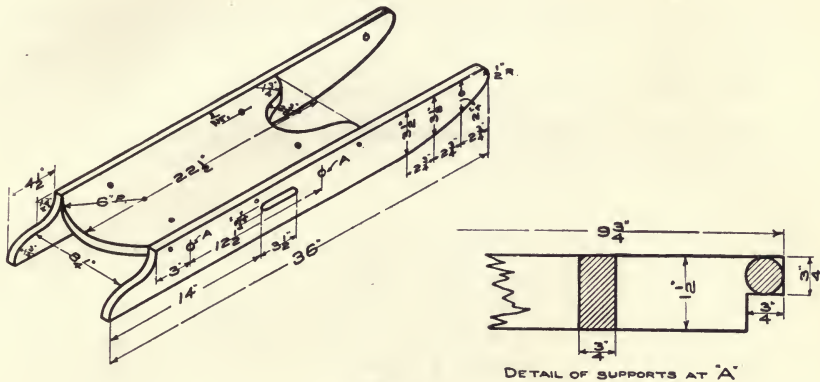

Fig. 51.

SLED

Whitewood or Ash. $\frac{3}{4}$ inch.

DIRECTIONS

1. Prepare a piece for the two runners about $36\frac{1}{4} \times 7\frac{1}{2}$ inches.
2. Construct the outline of runners and saw with splitting and turning saw.
3. Plane straight sides and use spoke-shave and knife for the curved parts.
4. If convenient, plan for top and the two supports in one piece, about $22\frac{3}{4} \times 10$ inches. Cut out supports from one side in one length.
5. Plane narrow faces of top and supports to required width.
6. Construct ends on top and support.
7. Use turning saw on curved ends of top and finish with spoke-shave, knife, and file.

ELEMENTARY SLOYD AND WHITTLING

8. Bore a $\frac{3}{4}$ -inch hole in a waste piece of wood. Finish round ends of supports with back saw and knife, and fit tight in $\frac{3}{4}$ -inch hole.
9. Mark out and bore holes on sides of runners. Finish the handle hole with $\frac{3}{4}$ -inch centre bit, compass saw, knife, and file.
10. Bore screw holes with $\frac{3}{16}$ -inch drill bit and use countersink.
11. Use $1\frac{1}{2}$ -inch screws No. 9.

NOTE: If under part of runners have the edges rounded off, they may be used without iron shoes. If children are able to do so, they may use hoop iron for shoes, punching, drilling, and countersinking holes for screws, bending it around the "toe" and "heel" and fastening with $\frac{1}{2}$ -inch No. 6 screws.

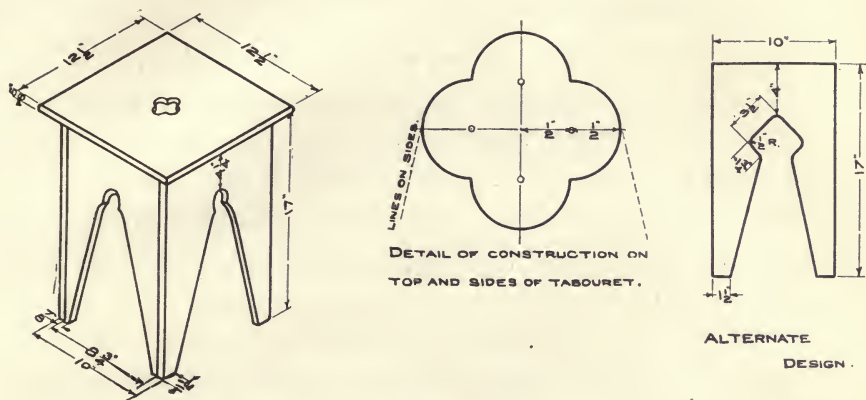

Fig. 52.

TABOURET

Whitewood or Basswood. $\frac{3}{16}$ inch.

DIRECTIONS

1. Saw out two pieces of wood for sides, one $34\frac{1}{2} \times 10\frac{1}{4}$ inches and the other $34\frac{1}{2} \times 9$ inches.
2. If too long to plane, cut each piece in halves and plane to required width.
3. Plane each end square to required length.
4. Draw construction on each of the four sides and cut with centre bit, splitting saw, knife, and spoke-shave.
5. Smooth inside of each piece with plane and sandpaper.
6. See that the narrow faces of the two narrow sides are perfectly square.

ELEMENTARY SLOYD AND WHITTLING

7. Make four cleats each $7\frac{1}{4} \times \frac{3}{4} \times \frac{3}{4}$ inch and bore two $\frac{3}{16}$ -inch holes through both sides.
8. Screw cleats on the inner side of the four pieces flush with top.
9. Space and mark for nails on the two broad sides, about 1 inch from ends and 3 inches between nails.
10. Use $1\frac{1}{2}$ -inch brads and drive nearly through at these marks.
11. Put glue on narrow side and nail each corner together quickly.
12. Sink nails, smooth sides with plane and sandpaper, take off sharp corners with sandpaper.
13. Prepare top $12\frac{1}{2} \times 12\frac{1}{2}$ inches.
14. Find centre, construct quarterfoil, and bore with 1-inch centre bit. To avoid splitting bore last hole so that lip and cutter of bit revolve in the direction of the grain.
15. Round narrow faces with plane about $\frac{1}{8}$ inch.
16. Smooth with plane and sandpaper.
17. Fit top on sides and fasten with $1\frac{1}{4}$ -inch screws through cleats.
18. Stain with walnut water stain. When dry, sandpaper lightly, polish with wax, and brush and give it a coat of shellac.

In addition to the articles described, a number of simple and useful objects may be designed by teachers and pupils.

STAINING AND POLISHING

GENERALLY it is best to keep the natural color of the wood, especially when the color and the grain have a pleasing appearance.

Some simple stain may be applied on such plain objects as would warrant it, and should be such as not to cover up the grain of the wood like paint. Walnut water stain is most satisfactory. It gives to the wood a dark brown color. If not dark enough, another coat should be applied after the first is dry. If too dark, water should be added. If a green color is wanted, a very small amount of green crystal aniline may be added to the water stain. The mixture, however, should first be tried on a waste piece of wood in order to ascertain if the color is right.

A simple method of polishing may be employed with or without previous staining by applying raw linseed oil and sandpapering lightly until dry. Then rub with soft shavings or cloth.

Another simple method of polishing is to apply "Butchers' Floor Wax" with a piece of cloth, brushing it with a stiff, clean brush as you would polish shoes. Similar wax may be made by mixing beeswax and turpentine to the consistency of soft clay. A coat of thin shellac, quickly and evenly applied with a brush, will make the finish more durable.

WHITTLING





WHITTLING

IN the Elementary Sloyd described in the first part of this book, whittling is not practised. As a general rule, children under twelve years of age have not sufficient strength or control of the hand to use the knife correctly. Whittling is recommended only when it is not possible to have the Elementary Sloyd, which requires a special room fitted up with benches and a variety of tools. Such an outfit is more effective educationally, but economically it is more expensive. Whittling can be done in the regular schoolroom by the regular teacher and with a comparatively inexpensive outfit.

By a skilful, experienced, and tactful teacher a whole class of the usual size in the public schools may be instructed simultaneously, but as in any work of motor training, or whenever the hands are employed to give expression to thought, the difference in individuals reveals itself so plainly that it is evident that the best educational results can be obtained only when free scope is given to individual abilities. Consequently, the number of children in the class should be limited. Drill, mass instruction, and various means of keeping children together may be employed and some fairly good visible results obtained, but in nine cases out of ten the educational effect on the child is very little, and in some cases more injurious than helpful. Hence, it is important that in this work a regular class be divided whenever it is possible.

The children should be taught to make sketches and working drawings of the simple models and should also learn to read printed drawings or such as are made by some one else.

The model and the drawing should at first be presented together by the teacher, and enlarged blackboard drawings may be made for the whole class to read. The aim of drawing is to give the pupil a correct mental picture of what he is expected to make, consequently it should always precede manual work.

ELEMENTARY SLOYD AND WHITTLING

The knife is the least mechanical and the most familiar of tools, and if correctly used teaches the pupil to think before he acts, because of its simultaneous demand upon the mind and the muscles of the arm, wrist, hand, and fingers.

The knife, however, is only one among the half hundred cutting tools used in sloyd. The value of Whittling alone as a means of education may not be very great, but it is believed that it may supply an educational need when practised under the following conditions:

1. The child should have sufficient strength to handle the knife correctly.
2. The whittling should be taught preferably by the regular teacher, who must be possessed of sufficient technical skill.
3. The position of the body and the movements used in the various exercises must be such as not to retard physical growth.
4. The work should as much as possible be done in erect standing position and the material should be large enough to permit freedom of movement.
5. The exercises should be carefully graded from the easy to the difficult and should be applied on objects useful to the worker and of artistic merit.
6. The knife should be of correct size and construction.
7. Wood suitable to the objects should be carefully selected and properly prepared.

GENERAL DIRECTIONS

1. With the point of the knife draw and cut in a good sitting position; but whittle, use the sandpaper, bore, etc., in an easy, correct standing position.
2. Always hold the rule on the edge in measuring, marking, and testing for dimensions, and place it flat on material when drawing lines.

3. Keep lead pencils sharp. Adjust the point of pencil to the same length as the point of the compass. In drawing arcs and circles hold compasses at the top between thumb and forefinger and keep needle point as nearly perpendicular to the surface as possible.

4. In squaring lines and testing, hold beam of the try square close to the true face. Whittled surfaces which are less than one-quarter of an inch should not be tested by the try square.

5. Use the eyes to test straightness, squareness, and symmetry of work before applying any other testing instruments.

6. Grasp the knife with the right hand, if right-handed, with the thumb bound over the fingers as in clenched fist.

7. Hold the wood at the end nearest you.

8. Rest forearm against body and cut from you and downward.

9. Do not cut from the very end, but start first beyond the hand, and turn the wood to finish.

10. Try to use the whole length of the blade by drawing it through the wood as you cut. Do not scrape.

11. If you have a broad face to cut, take off the edges first.

12. Never cut clear across an end or the fibres, but always from the sides toward the middle.

13. Do not use sandpaper before the model is as well finished as possible with the knife. Remove pencil marks with an eraser.

14. Stretch sandpaper over a block with the fingers when sandpapering flat surfaces. Remember that the purpose of using sandpaper is merely to make the object clean and smooth and not to reduce dimensions.

WORKING DIRECTIONS FOR WHITTLING

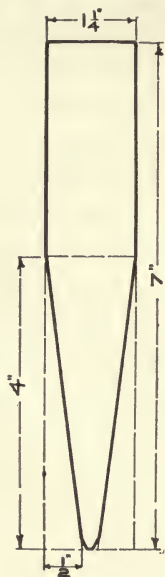

Fig. 53.

1.—PLANT LABEL

Basswood. $\frac{3}{15}$ inch.

DIRECTIONS

Wood sawed off $7\frac{1}{4}$ and split to $1\frac{1}{2}$ inches.

1. Draw a straight line near and parallel to one split edge and whittle to it.
2. Mark width at each end, connect points by a line, and whittle to it.
3. Construct point according to drawing and whittle.
4. Measure length. Square line across and whittle from corners toward centre.
5. Sandpaper with block, narrow faces first, then broad faces.

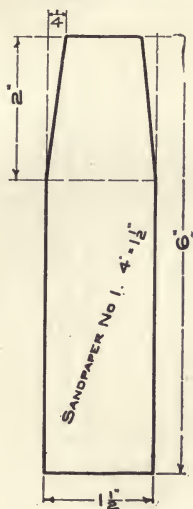

Fig. 54.

2.—PENCIL SHARPENER

Whitewood. $\frac{3}{16}$ inch.

DIRECTIONS

Wood sawed off and split $6\frac{1}{4} \times 1\frac{3}{4}$ inches.

1. See 1 and 2 in Model No. 1.
2. Square line across near one end and whittle to it.
3. Measure length and draw line and whittle.
4. See 4 in Model No. 1.
5. See 5 in Model No. 1.
6. Mark out on the back of sandpaper a piece the proper size and cut with a knife kept for the purpose.
7. Apply a thin coat of Le Page's Liquid Glue to back of sandpaper and press it firmly upon the wood.

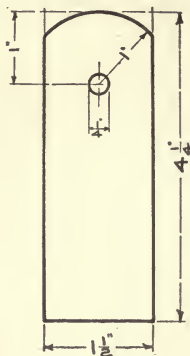

Fig. 55.

3.—KEY TAG

Basswood. $\frac{3}{16}$ inch.

DIRECTIONS

Wood prepared $4\frac{1}{2} \times 1\frac{3}{4}$ inches.

1. See 1 and 2, Model 1.
2. Locate point and draw arc with compass. Whittle to line.
3. Bore hole at centre with gimlet bit, taking care to keep the bit perpendicular. When centre point appears, turn wood and finish.
4. See 4 in Model No. 1.
5. See 5 in Model No. 1.



Fig. 56.

—MATCH SCRATCHER

Whitewood. $\frac{1}{8}$ inch.

DIRECTIONS

Wood prepared $6\frac{1}{4} \times 2\frac{1}{2}$ inches.

1. See 1 and 2, Model No. 1.
2. Draw centre line.
3. Locate points for centres of semicircles at each end, and square lines across at these points.
4. Draw semicircles.
5. Cut square shoulders by notching. Finish to semicircles, taking care to whittle with the grain.
6. Bore hole with fine bradawl at the centres.
7. See 5 in Model No. 1.
8. See 6 and 7 in Model No. 2.

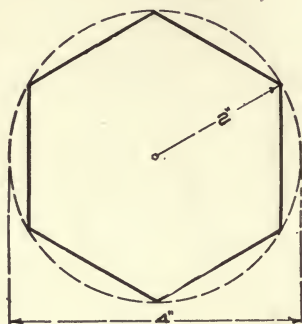

Fig. 57.

5.—STAND FOR PAPER FILE

Whitewood. $\frac{1}{4}$ inch.

DIRECTIONS

Wood prepared $4\frac{1}{4} \times 3\frac{3}{4}$ inches.

1. Find centre of wood and draw straight line with the grain.
2. Draw a circle of 2-inch radius.
3. Construct hexagon, beginning at the intersection of the centre line.
4. Whittle the two sides running parallel to the grain first, then the others.
5. Draw and cut a bevel of $\frac{1}{8}$ inch on the side free from pencil marks and make it round by cutting off sharp edges.
6. See 5 in Model No. 1.
7. For the file use a steel wire brad 4 inches in length No. 14. Sharpen point on the oil stone and drive it through from the under side at centre.

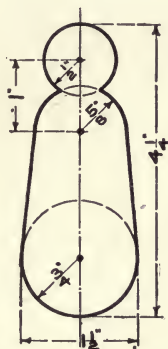

Fig. 58.

6.—TAG

Whitewood. $\frac{1}{8}$ inch.

DIRECTIONS

Wood prepared $4\frac{1}{2} \times 1\frac{3}{4}$ inches.

1. See 1 in Model No. 5.
2. Locate points for arcs and draw circles.
3. Draw straight lines through tangents.
4. Whittle to straight line first and then to arcs.
5. See 5 in Model No. 1.

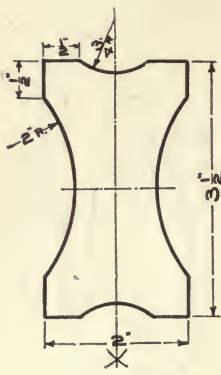

Fig. 59.

7.—THREAD WINDER

Basswood. $\frac{3}{16}$ inch.

DIRECTIONS

Wood prepared $3\frac{3}{4} \times 2\frac{1}{4}$ inches.

1. See 1 and 2 in Model No. 1.
2. Square line across near one end and whittle to it.
3. Measure length, square line, and whittle.
4. Measure and draw two centre lines, dividing width and length.
5. Mark points for corners.
6. Locate centres for arcs with compasses from these points.
7. Draw arcs and whittle.
8. Sandpaper curves by hand, and straight faces with block.

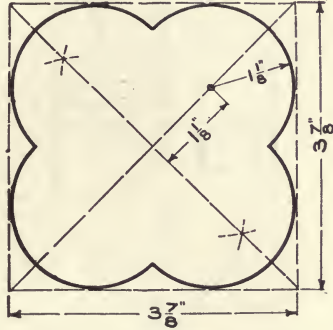

Fig. 60.

8.—MAT

Whitewood. $\frac{1}{8}$ inch.

DIRECTIONS

Wood prepared about 4 x 4 inches.

1. Draw one diagonal. Erect perpendicular at centre.
2. Find centre for quarterfoil and construct semicircles according to drawing.
3. Whittle to line, noting carefully the direction of the grain.
4. See 5 in Model No. 1.

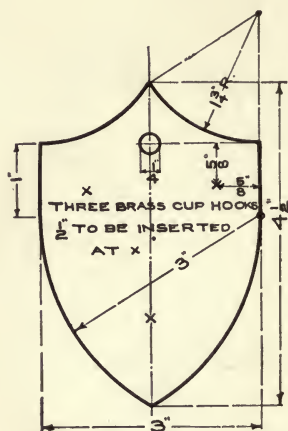

Fig. 61.

9.—KEY BOARD

Whitewood. $\frac{3}{16}$ inch.

DIRECTIONS

Prepare wood $4\frac{1}{2} \times 3\frac{1}{2}$ inches.

1. Make the piece 3 inches wide.
2. Draw a centre line and construct shield according to drawing.
3. See 3 in Model No. 8.
4. Bore hole and mark places for three hooks.
5. Sandpaper.
6. Insert hooks.

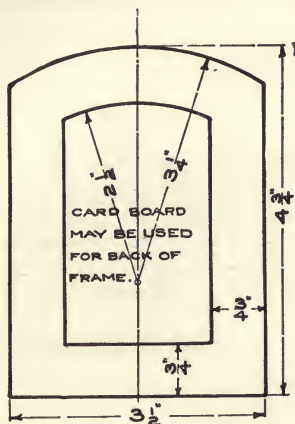

Fig. 62.

10.—PICTURE FRAME

Basswood. $\frac{1}{8}$ inch.

DIRECTIONS

Size of frame may be decided by pupil with the teacher's approval.

1. Cut two sides and one end square.
2. Draw centre line and construct according to drawing.
3. Place wood firmly on a cutting-board, and with point of knife score and notch lines across the interior about $\frac{1}{8}$ inch inside of line until the knife point is through the wood. Cut and score carefully, in a similar manner, the other two sides. Whittle the interior to line.
4. Whittle outer curved end.
5. Sandpaper.
6. The frame may be stained with walnut water stain, and waxed and brushed on the front and narrow faces.
7. Cut cardboard for the back $\frac{3}{4}$ inch wider and $\frac{3}{8}$ inch longer than opening. Cut strips of cardboard $\frac{1}{4}$ inch wide and glue on three sides of the back of cardboard, and, when dry, glue onto frame, making a pocket for the picture.

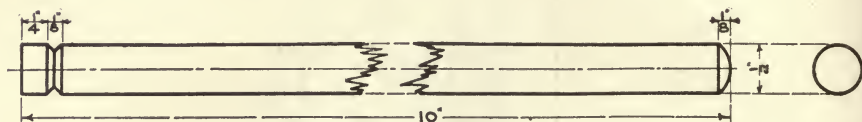

Fig. 63.

11.—MOP HANDLE

White Pine. $\frac{1}{2}$ inch.

DIRECTIONS

Straight-grained wood should be selected about 11 inches long and split about $\frac{3}{4}$ inch wide.

1. See 1 and 2, Model No. 1. Whittle with long, steady strokes.
2. Whittle edges at both ends until octagonal. This will serve as a guide in cutting the rest of the stick.
3. Cut the next set of corners, making it sixteen-sided, and then cylindrical.
4. Finish one end. Mark and notch around this end according to drawing.
5. Cut length and round the end $\frac{1}{8}$ inch, taking care to keep intersection sharp.
6. Sandpaper by hand.

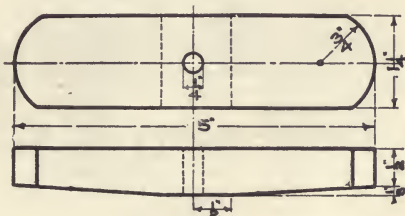

Fig. 64.

12.—DOOR BUTTON

Whitewood. $\frac{5}{8}$ inch.

DIRECTIONS

Prepare wood $5\frac{1}{4} \times 1\frac{1}{2}$ inches.

1. Draw lines and whittle two sides straight and square.
2. Mark and draw oblique lines for under part and whittle.
3. Draw a centre line and arcs at both ends and bore hole from both sides.
4. Whittle curved ends.
5. Sandpaper.

(This button may be used for a door which is flush with the casing.)

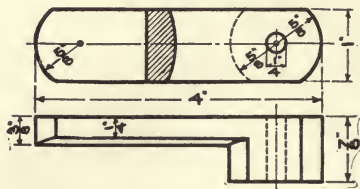

Fig. 65.

13.—DOOR BUTTON

White Pine. $\frac{3}{8}$ inch.

DIRECTIONS

Prepare wood $4\frac{1}{2} \times 1\frac{1}{4}$ inches.

1. See 1 in Model No. 12.
2. Construct on the two narrow sides according to drawing.
3. Draw centre line and arcs. Draw on both sides at thick end.
4. Notch and whittle the thin part of button.
5. Whittle the curved ends and bore hole from both sides.
6. Make the under part of thin end a little curved to avoid friction (see cross section).
7. Sandpaper.

(This button may be used for a door with a moulding.)

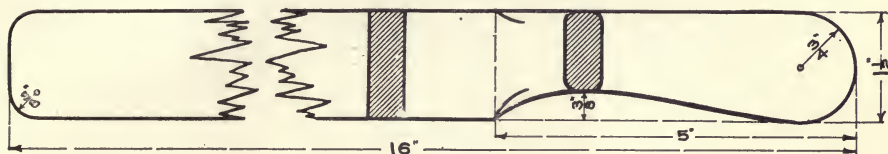

Fig. 66.

14.—BAT FOR TIP CAT

Whitewood. $\frac{1}{4}$ inch.

DIRECTIONS

Prepare wood $16\frac{1}{4} \times 1\frac{3}{4}$ inches.

1. Whittle wood straight and square, making width according to drawing.
2. Construct handle and whittle.
3. Measure and cut length.
4. Draw arc at corners and whittle.
5. Round edges of handle according to drawing.
6. Sandpaper.

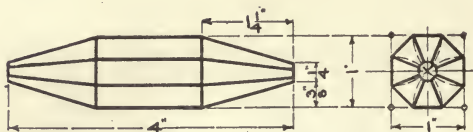

Fig. 67.

15.—TIP CAT

White Pine. 1 inch.

DIRECTIONS

Prepare wood $4\frac{1}{4} \times 1\frac{1}{4}$ inches.

1. See 1, Model 14.
2. Cut one end square, measure length, square line, and cut.
3. Measure and square lines around for pointed ends.
4. Measure and draw $\frac{1}{4}$ inch square at centre on each end.
5. Draw oblique lines for points on two opposite sides and whittle.
6. Draw and whittle the other sides in a similar manner.
7. Whittle middle part octagonal.
8. Whittle pointed ends octagonal.
9. Sandpaper with block.

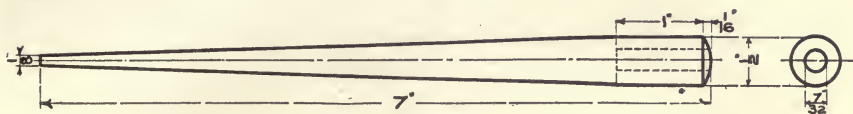

Fig. 68.

16.—PEN-HOLDER

Red Cedar. $\frac{1}{2}$ inch.

DIRECTIONS

Prepare wood $7\frac{1}{2} \times \frac{3}{4}$ inch.

1. See 1 in Model No. 14.
2. Draw diagonals at one end and bore hole with $\frac{7}{32}$ -inch drill bit.
3. Whittle peg and insert before cutting right length. Try if a pen can be easily inserted.
4. Measure and draw oblique lines on one side and whittle.
5. Proceed in a similar way on the other side.
6. Whittle edges, making it octagonal.
7. Whittle next set of edges, making it round.
8. Whittle thick end curved. Measure length and cut.
9. Sandpaper.

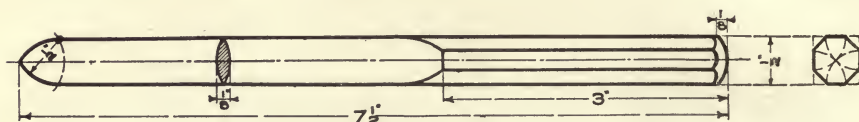

Fig. 69.

17.—LETTER OPENER

Sweet Gum. $\frac{1}{4}$ inch.

DIRECTIONS

Prepare wood $8 \times \frac{5}{8}$ inch.

1. See 1, Model No. 14.
2. Mark length of handle and square line around.
3. Draw centre lines on the two opposite planed faces.
4. Draw lines for thickness of blade on each side of centre line.
5. Whittle thickness of blade flat.
6. Whittle handle octagonal.
7. Whittle blade curved to centre lines (see cross section).
8. Cut the curved end of handle.
9. Measure length, draw point of blade, and whittle.
10. Sandpaper octagonal handle with block, blade and ends by hand.

See that blade is sharp enough to cut paper.

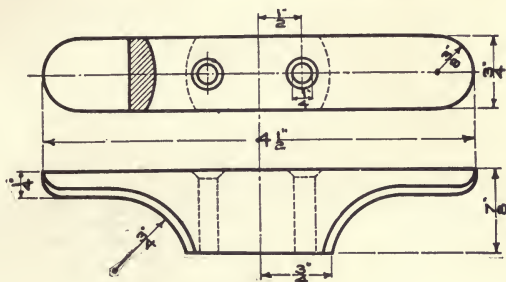

Fig. 70.

18.—LINE CLEAT

Birch. $\frac{3}{4}$ inch.

DIRECTIONS

Prepare wood $4\frac{1}{2} \times 1$ inch.

1. See 1 in Model No. 14.
2. Measure length and find middle, square lines around at these marks.
Draw centre line on top.
3. Construct side view according to drawing.
4. Cut to these lines, flat.
5. Draw semicircles on top and arcs at bottom.
6. Cut semicircles and curved under part.
7. Bore holes.

NOTE: A variation in shapes and sizes of this cleat may be made. The long sides and top may be curved, making it narrower at ends and more beautiful. The cleat may be used for boats, flag-pole lines, or clothes-line. It is considered better than those made of metal.

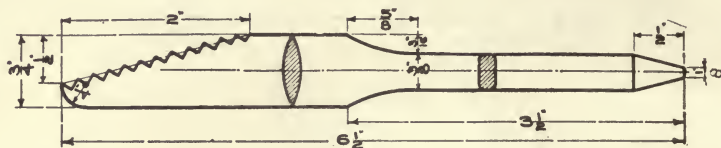

Fig. 71.

19.—CLAY MODELING TOOL

Maple. $\frac{3}{8}$ inch. (Straight-grained.)

DIRECTIONS

Prepare wood $6\frac{3}{4} \times \frac{7}{8}$ inch.

1. See 1 in Model 14.
2. Mark and cut the required length.
3. Make construction complete on one side according to drawing.
4. Whittle to lines.
5. Model the blade to a sharp edge and round the corners of handle.
6. Cut notches on back of blade, and point the four sides on end of handle.
7. Sandpaper, making the knife edge strong and durable.

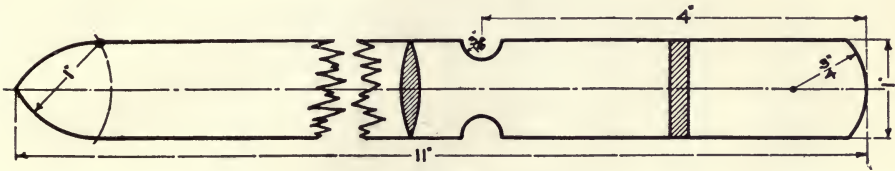

Fig. 72.

20.—PAPER KNIFE

Maple. $\frac{3}{16}$ inch. (Straight-grained.)

DIRECTIONS

Prepare wood $11\frac{1}{2} \times 1\frac{1}{4}$ inches.

1. See 1, Model No. 14.
2. Construct knife on one side according to drawing.
3. Whittle to lines.
4. Draw centre lines on narrow faces of blade.
5. Whittle blade curved (see cross section).
6. Sandpaper semicircular cuts by putting sandpaper around the lead pencil, and the rest with block.

WHITTILING OUTFIT

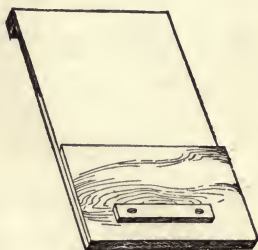

Fig. 73.

DESK TOP FOR WHITTILING COURSE

Regular size, 9 x 15 inches.

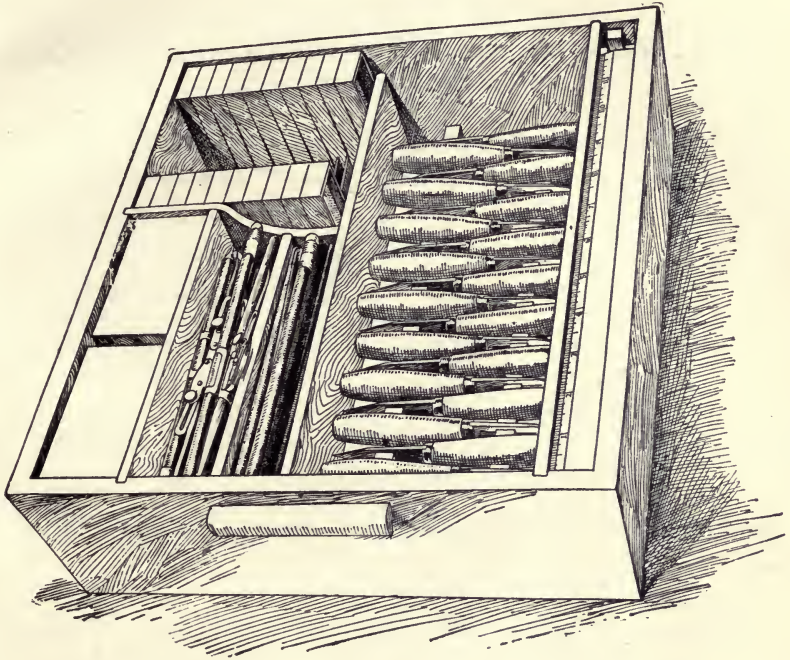

Fig. 74.

BOX FOR WHITTLING OUTFIT

This box is designed for a class of twenty in Whittling Course. Contains twenty of each—Lead Pencils No. 3; Rules, one foot; Sloyd Knives, 3-inch blade; New Pencil Compasses, Try Squares 4-inch, Sandpaper Blocks. Price, \$15.

ELEMENTARY SLOYD AND WHITTLING

CHEST CONTAINING TEACHERS' TOOLS AND SUPPLIES AS
FOLLOWS:

Cross-cut Saw, 22-inch; Try Square, 8-inch; Hatchet No. 1, Clamp
Vise; Bit Brace, 2 drill bits, with bit points $\frac{7}{32}$ inch; 6 Auger-bit Gim-
lets, $\frac{1}{4}$ -inch; India Oil Stone, Oil Can, 2 Honing Straps, 2 pounds Cotton
Waste, 2 quires Sandpaper No. 0 and No. 1.

AMOUNT OF WOOD FOR THE FIRST TEN MODELS FOR
TWENTY PUPILS.

The wood should be of best quality, straight-grain, kiln-dried, and
planed.

7	square	feet	$\frac{1}{8}$ -inch	Whitewood,	approximate	width	6	inches.
5	"	"	$\frac{3}{16}$ -	"	"	"	5	"
3	"	"	$\frac{1}{4}$ -	"	"	"	8	"
5	"	"	$\frac{1}{8}$ -	Basswood	"	"	6	"
5	"	"	$\frac{3}{16}$ -	"	"	"	6	"

If the teacher has no facilities for cutting up the wood, pieces cut to
the approximate length and width may be ordered. State kind and
thickness as well as number of pieces needed of each kind.

ILLUSTRATION OF SPONTANEOUS
CREATIONS

ELEMENTARY SLOYD AND WHITTLING

NAMES OF OBJECTS IN FIG. 75 AS GIVEN BY THE
CHILDREN

- | | |
|------------------------------------|---|
| 1. Chain (showing working method). | 22. Row-boat. |
| 2. Chain (complete). | 23. Clock. |
| 3. Dagger. | 24. Puzzle (made from one piece). |
| 4. Sword. | 25. House with attic. |
| 5. Wheelbarrow. | 26. Cuban sword. |
| 6. Pistol. | 27. The pig that swims in the sea. |
| 7. Eyeglasses. | 28. Camel. |
| 8. Pencil-box. | 29. Doll. |
| 9. Horse's head. | 30. Pistol. |
| 10. Razor. | 31. Catapult. |
| 11. Hatchet. | 32. Double-runner. |
| 12. New York dude. | 33. Sled. |
| 13. Rocking-chair. | 34. <i>Mayflower</i> . |
| 14. "The Old Oaken Bucket." | 35. Fulton's boat. |
| 15. Rolling-pin. | 36. Steamboat. |
| 16. Revolver. | 37 and 38. Yoke of oxen with sled. |
| 17. Ladder. | 39. House (made by Thomas Stringer, deaf, dumb, and blind). |
| 18. Shovel. | 40. Saw-horse. |
| 19. Bat and ball. | 41. Sled. |
| 20. Spade (for greasing axles). | 42. Carpenter's bench. |
| 21. Canoe. | 43. Lumber wagon. |

This collection of objects, made without supervision or direction on the part of the teacher, is of special value to those interested in child study. It is suggestive in many ways. The child's imagination, interest, and creative instinct are manifested in these bits of wood, and those who are planning courses of work may "catch some hints" from such productions.



Fig. 75.—Spontaneous Creations in Wood by Children under Twelve Years of Age.

