

PRACTICAL IRRIGATION

ITS VALUE AND COST

WITH TABLES OF COMPARATIVE COST, RELATIVE
SOIL PRODUCTION, RESERVOIR DIMENSIONS
AND CAPACITIES, AND OTHER DATA
OF VALUE TO THE PRACTICAL FARMER

BY

AUG. J. BOWIE, JR.

A. B., HARVARD; S. B. MECHANICAL ENGINEERING, MASS. INST. OF
TECHNOLOGY; S. B. ELECTRICAL ENGINEERING,
MASS. INST. OF TECHNOLOGY



NEW YORK
McGRAW PUBLISHING COMPANY

1908

**COPYRIGHTED, 1908,
BY THE
MCGRAW PUBLISHING COMPANY,
NEW YORK**

**Stanbope Press
F. H. GILSON COMPANY
BOSTON, U.S.A.**

125066
DEC 14 1908

1387975

SWY
-B67

PREFACE

THE prospect of converting desert land into a flourishing country lends to irrigation an attractive aspect. Some people, carried away with the possibilities of irrigation, lose sight of the all-important financial end of the question, and make extensive investment in apparatus which is unnecessary or unsuited to the work to be done. Others, from ill-advised ideas of economy, endeavor to irrigate their land without properly laying out their plant, and spend for labor alone many times the cost of a suitable installation. To speak intelligently about irrigation, we must know the *cost* and the *value*, not only of the plant as a whole, but of the individual parts thereof. These are subjects of primary importance. The actual cash outlay necessary for operation is often considered as the cost of irrigation, without making any allowance for interest or depreciation on the investment in the irrigation plant. Thus we find the popular conception that water obtained from an artesian well is supplied at no expense, while pumped water, owing to the expense of a pumping plant, is by no means so desirable. The first cost of the well is entirely lost sight of. Although it is highly desirable to avoid the expense for fuel or attendance, still the fixed charges on a deep artesian well, when the flow is small, may easily make artesian water more expensive than water pumped under low lift.

Where the cost of obtaining water is high, expensive means of preventing seepage may be justified. Where fuel is high, and the plant is operating under a high lift, an efficient high-grade plant should be installed. Where fuel is cheap, and cheap low-grade labor is available, it may be folly to install a high-grade plant with its added expense and complication. How shall we know how far to go and what kind of apparatus to install? Obviously we can give no intelligent answer unless we know the *cost* and *value* of the plant as a whole, as well as of its individual parts. It is the endeavor of the writer to furnish data for determining

the cost and value of irrigation, and of the apparatus and machinery which may be used therein.

In a country rich in natural resources, little attention is usually given to the economic utilization of its wealth. It is difficult for ideas of economy to receive serious consideration, and reckless waste is likely to exist until the development reaches such a stage that the scarcity of material makes itself keenly felt. This is particularly true in the case of the use of water for irrigation. In arid America the available water supply is sufficient for the irrigation of only a very small percentage of the land susceptible of irrigation. Without storage, much of this water will run to waste. Economic considerations require the ultimate construction of large reservoir systems for the storage of this water.

Present development is governed by the present cost; but future development will be governed by the value of the water in increased production, rather than by the present cost of obtaining it. The problem of the economic use of water is becoming of constantly increasing importance. In many places the entire supply available is consumed by present methods of irrigation. Although apparently the irrigation limit has been reached, the storage of water, the prevention of seepage losses, and the use of proper scientific methods of applying the water so as to prevent to a large extent losses by evaporation will usually increase greatly the area which may be irrigated. For instance, the losses of water by evaporation from the soil which may be avoided by proper irrigation are often astonishingly great. This is well brought out by the important investigations conducted by Professor Fortier, Chief of Irrigation Investigations of the United States Department of Agriculture.

The subject of earth reservoirs has been treated at some length as it is felt that they have a large field of usefulness. The figures given for large reservoirs are intended rather to indicate the considerations which should be used in their design, and also to suggest their practicability or impracticability, as the case may be, than to be of use in individual cases where the topography of the ground must always be considered.

Part of the data presented in this book is the result of investigations by the author while acting as expert for the U. S. Department of Agriculture, and is summarized from the following bulletins published by the Office of Experiment Stations: "Irrigation in

PREFACE.

v

Southern Texas," published as separate No. 6 of Bulletin No. 158, and "Irrigation in the North Atlantic States," published as Bulletin No. 167.

The author is indebted to Mr. A. M. Hunt and to Mr. Frank Adams for many valuable suggestions in connection with the preparation of this book.

AUG. J. BOWIE, JR.

SAN FRANCISCO, Jan. 2, 1908.

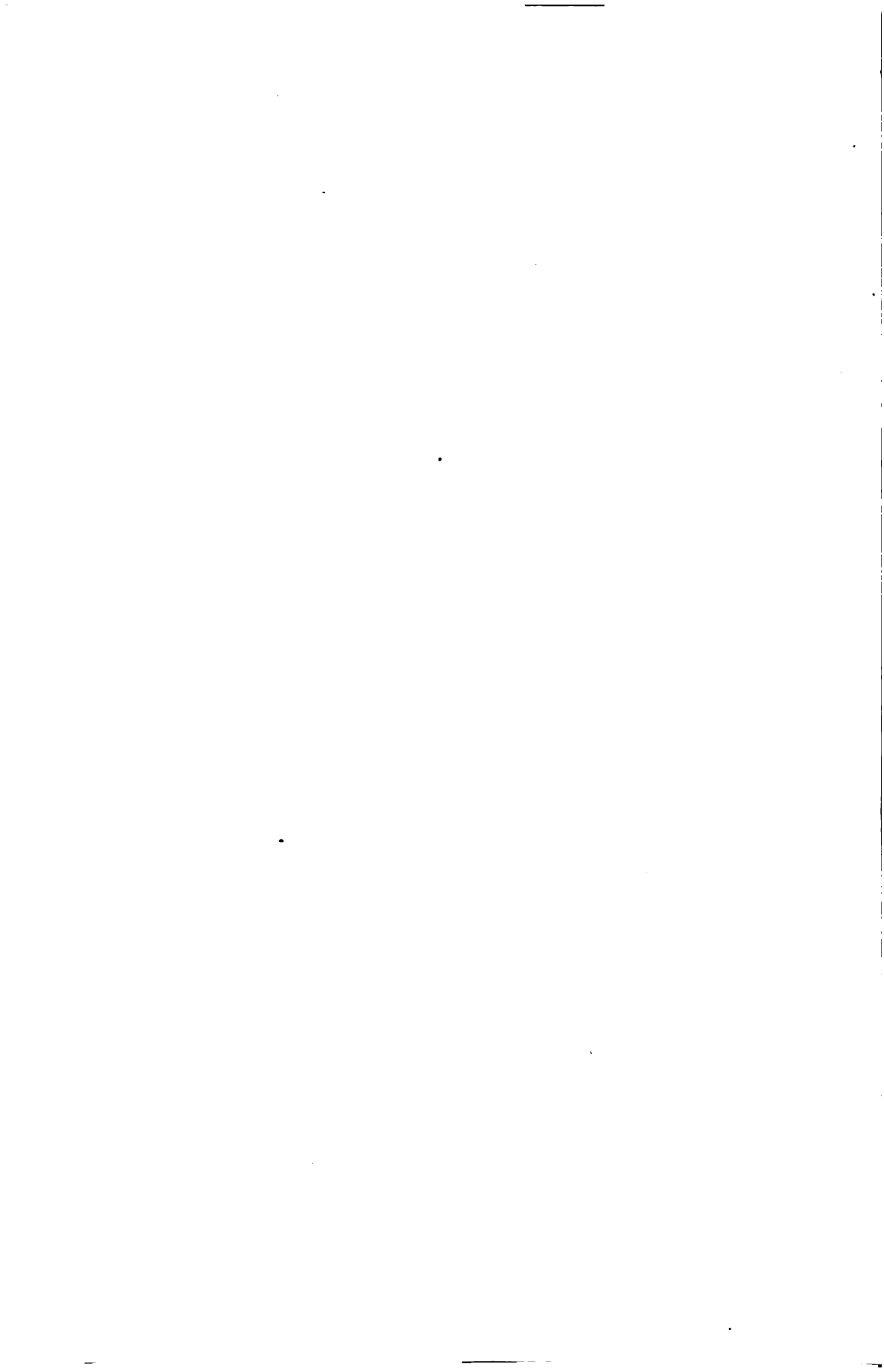

CONTENTS

CHAPTER	PAGE
I. WHAT IRRIGATION HAS ACCOMPLISHED	1
II. UNITS IN USE	11
III. METHODS OF IRRIGATION IN USE	20
IV. EVAPORATION	23
V. ACTUAL RESULTS OF IRRIGATION	34
VI. DIFFERENT SOURCES OF WATER SUPPLY	42
The Natural Flow of Streams — Reservoirs — Natural Reser- voirs — Cost of Stored Water — Value of Location — Artificial Reservoirs — Canals as Storage Basins — Underground Supply.	
VII. METHODS AND APPLIANCES FOR OBTAINING WATER	55
Conduction and Distribution of Water — Calculation of the Flow of Water in Ditches — Measurement of Flow of Water — Natu- ral Reservoirs — Wells.	
VIII. WELLS	85
Law of Flow of Wells — Methods and Cost of Boring Wells.	
IX. PUMPS AND PUMPING MACHINERY	103
X. IRRIGATION NEAR BAKERSFIELD	128
XI. METHODS OF CHARGING FOR WATER IRRIGATION	141
XII. ECONOMIC LIMIT OF IRRIGATION	147
XIII. EARTH TANKS	153
XIV. LARGE ARTIFICIAL RESERVOIRS	166

CHAPTER	PAGE
XV. LARGE RESERVOIRS FOR THE STORAGE OF ARTESIAN WATER	187
XVI. ECONOMIC USES OF RESERVOIRS AND TANKS	199
APPENDIX A	203
APPENDIX — CIRCULAR EMBANKMENTS	219
Economic Design of Large Reservoirs on Level Ground — on Sloping Ground — on Sloping Ground, for Fixed Belt of Rip- rap-lined Reservoirs Constructed on Sloping Ground, with Fixed Width of Riprap — of Large Lined Reservoirs of a Given Capacity — of Reservoirs on Level Ground for the Stor- age of Artesian Well Water — Cox's Formula.	
INDEX	229

PRACTICAL IRRIGATION.

CHAPTER I.

WHAT IRRIGATION HAS ACCOMPLISHED.

Of all the varied industries and means of producing wealth, there is none which ever has or probably ever will compare in importance with agriculture. The value of our farm products is far in excess of the value of those from any other source, and is of inestimably greater benefit to the world. The principal elements affecting the growth of plant life consist of the soil, climate, cultivation, and the amount of moisture in the ground; and the best results are obtained only from a proper combination of the same.

In much of the country the soil and climate are suitable for the growth of crops of various kinds, and cultivation is entirely under the control of the farmer, but the amount of moisture in the ground is such as to preclude successful farming, in areas of enormous extent, owing to either too large or too small a water supply. The proper amount of moisture may be artificially retained in the soil by supplying it by irrigation or removing it by drainage.

The United States may be divided into three zones, according to the annual rainfall: The humid zone, where the rainfall is over 30 inches per year; the semi-arid zone, where the rainfall varies between 20 and 30 inches per year; and the arid zone, where the rainfall is less than 20 inches per year.

The arid zone is situated mainly in the western half of the country, while the humid zone lies to the east; and intermediate between them is the semi-arid or semi-humid zone, as it is sometimes called, the line of demarcation between which and the other zones is not sharp. This zone includes in general North and South Dakota, western Nebraska, western Kansas, Oklahoma and the Pan Handle, and part of central Texas.

Fig. 1 is a map of the three zones of the United States, as given in "Irrigation in the United States" by F. H. Newell.

It is popularly supposed that the designation "arid" implies that the land is largely of a desert character. Such, however, is not the case, aridity simply implying that the land receives a comparatively limited supply of moisture, and does not have any reference to the nature of the soil. In fact, only 7 per cent of the arid region is composed of desert land. The area of the arid zone consists of two-fifths of the total area of the country, and on much of this land, farming, without irrigation, is impracticable, and the land is almost worthless; while with irrigation it can be



Fig. 1. U. S. Map. Zones of Rainfall.

made highly productive and of great value. All the other elements of successful farming are present except moisture, and it needs but the application of water to the land to transform the country from a wilderness to a prosperous and productive property. The growth in value due to irrigation is by no means confined to the land alone, but results in general benefit to the country in the establishment of prosperous communities and the construction of railroads, which open up the land and carry its products to market. The growth in land value due to irrigation is remarkable, showing, however, that the real value of the land is absolutely dependent on the application of water thereto. For example, irrigable land in Northern Colorado along the Cache Poudre River, sells readily, with the water right attached, for from \$100 to \$200 per acre, while adjacent land, similar in every respect, except for the absence of water rights, is worth only a few dollars per acre. The same is true in many sections in the west where the value of irriga-

tion is appreciated. In some localities — notably in Southern California — water rights are much more valuable.

As arid land is usually valuable only when water is applied thereto, it has been held by some of the leading authorities on irrigation that where the water was limited, the water right should be inseparably attached to the land. This is the law in some states, and in general results in material benefit, serving to prevent speculation in water rights, with its consequent ills.

Irrigation consists in supplying artificially to the soil the moisture needed for the growth of plants. All soils are composed of minute grains or particles between which are void spaces. These voids will in general range from 30 per cent to 50 per cent of the total volume, depending on the relative sizes of grains, and on their arrangement. For example, crushed rock will have a certain percentage of voids, but if gravel be mixed with the rock, so as not to increase its volume, it will partially fill the spaces between the rock, and the mixture will have a much smaller void space than the rock alone. If this mixture be shaken, the rock and gravel will readjust themselves, settling, and leaving a still smaller void space. If the entire void space in a soil is filled with water, the soil is said to be saturated.

The growth of plants requires a certain amount of moisture in the soil to feed the nutriment therefrom to the roots of the plants. Either too much or too little moisture is detrimental to plant growth, and efficient irrigation consists in supplying the requisite amount of moisture to the soil. However, a fairly wide range of percentage of moisture in the soil will in general give satisfactory results. When the soil contains about 20 per cent of saturation water, it is dry to all appearances, and is not suitable for plant growth.

According to Professor Fortier, about 60 per cent of the volume of clay soils and 40 per cent of the volume of sandy soils are open space, while the loams range between. The moisture in soils may be regarded as composed of two parts — the hygroscopic moisture which clings to the grains and requires a considerable amount of heat to drive it off, and the free moisture which furnishes nourishment to the roots of plants. About one pound of free moisture per ten pounds of soil is required for a good plant growth. This is an approximation varying of course somewhat with the nature of the soil and crop, and can be tested in the

following manner: Take an average sample of the soil between the highest and lowest levels of the roots, weigh the same, and then spread it out in a pan in a thin layer and dry it for a day in the sun, weighing again. The difference is the free water. The sample taken where the plants are growing well will show the proper amount of moisture.

The moisture required for plant growth will vary with the condition of the crop. For example, crops such as onions, strawberries, etc., require moisture, especially during the time the bulbs and the berries are maturing. Climatic conditions largely affect the irrigation requirements. It is not sufficient that the total rainfall be up to a certain quantity, but the distribution thereof should also be such as to insure the proper moisture in the ground during the growing season. In many arid countries almost the total supply of moisture must be provided by irrigation, while in humid countries irrigation is simply a protection against the effect of a drought. The depths of the roots of the plants have a very important effect on the sensitiveness of the plants to dry spells. The moisture in the soil, except just after a rainfall or irrigation, will, within limits, at first increase with the depth, the surface layers drying off first. Deep-rooted plants are not so sensitive to short droughts as plants whose roots are nearer the surface.

The moisture applied to the soil is disposed of in three manners. A large part is evaporated from the surface of the soil, another part drains through the soil and runs to waste, while the third part is useful in nourishing vegetation, in the formation of the crop, and in providing for the transpiration losses thereof.

The leaves of plants are provided with hundreds of minute openings per square inch. It is through these openings that the plant receives from the atmosphere the carbon necessary for the growth of the plant, which unites with the sap from the effect of the light rays. These openings into the central portion of the leaf furnish passages for the evaporation of water from the leaf. This is known as the transpiration loss, the moisture being carried off by the air.

The openings into the leaves close up automatically when it is dark, thus checking the loss of moisture which would otherwise occur. So nature has provided plants with means for conserving to the utmost the supply of moisture so necessary for their growth.

Tests by Professor King have shown the remarkable fact that transpiration losses occur only when it is light, and that when it is dark they practically cease. Also, unlike losses by evaporation, they remain practically independent of the amount of moisture in the air, but are about equal on wet or dry days. The wind, however, will increase considerably losses of this nature.

In climates where the air is moist, the soil evaporation is greatly reduced; while, if the climate is dry and subject to winds, the evaporation will be greatly increased.

The nature of the soil plays an important part in the effect of irrigation. It is important in many soils where evaporation losses may be high, to take precaution to reduce the same. Particularly is this true of a soil which tends to crack open when drying after an irrigation. A fine protective mulch of earth forms the greatest protection against evaporation losses; and where it is possible to do so, cultivation as soon as is practicable after irrigation will be highly beneficial in preventing evaporation. It should be remembered that irrigation cannot take the place of cultivation. Experiments have shown that when the surface is kept moist for four days after water is turned on, from 1 to 3 inches in depth will be lost by evaporation. If the soil is saturated this loss will approximate the higher figure, but, if only moist, it will be nearer the lower figure.

Deep soils will allow the storage of considerable quantities of water, but this is of value to plant growth mainly where the roots of the plants are also deep. If the subsoil be gravelly, care should be taken not to apply water in such quantities that a large amount may be lost by seepage through the same.

On the other hand, a clay subsoil, near the surface, may hold the water so high that evaporation losses may be large. The depth to which water will penetrate will depend on the nature and condition of the soil with respect to dryness.

In general, from 4 to 9 inches of water will be required to moisten the soil to a depth of 4 feet.

The effect of the application of water to land will be to raise the level of the ground water, carrying with it the various salts dissolved from the soil. This is brought to the surface of the ground by capillary action, where it leaves the salts when it evaporates. Should these salts be in quantity and of a detrimental character, they will accumulate until they destroy plant life.

The various compositions known as alkali and also sodium chloride form the main sources of trouble. In land where the drainage is not naturally good, and where trouble of this nature is likely to be encountered, it may be obviated by installing artificial drainage. This, however, is usually quite expensive, and hence undesirable if it can be avoided. Economy in the use of water and frequent cultivation will be of great assistance in preventing damage from injurious salts in the soil, in addition to effecting excellent results in checking evaporation.

In addition to possible damage from the salts in the soil, the rise of the ground water may cause serious damage to plant growth, by excessive moisture near the roots of the plants. The proper drainage of land is essential where extensive irrigation is to be employed, and in many places large tracts of land have been injured by receiving the drainage from adjacent irrigated land, the ground water rising sufficiently high to drown out the plant growth and in some cases to make a bog out of the country. Before endeavoring to make extensive irrigation development, it is very essential to see that the land is so situated that it has the advantages of natural drainage, since otherwise it may be necessary to install an artificial drainage system, adding greatly to the expense. In all cases, however, economy in the use of water is doubly beneficial because it decreases the cost of irrigation and also the dangers arising from poor drainage. So drainage is as important for plant growth as is irrigation, either an excess or deficiency of water resulting injuriously. Drainage prevents the stagnation of the ground water, and allows the plant roots to draw from the air in the soil the oxygen necessary for plant growth. Where injurious salts are present in the ground, it also prevents them, after they are dissolved, from rising and killing vegetation.

Excessive moisture renders the ground so soft that it is impossible to work it, so drainage may be of a threefold benefit.

The value of irrigation depends largely on the nature of the crop as well as on the yield of unirrigated crops. The general subject of values and costs is a matter on which there is liable to be considerable difference of opinion, even in the same case. It is endeavored in this book to give as far as possible a uniform

standard of determining costs. The actual cost will be made up of three parts:

1. Actual cash running expenses.
2. Interest and taxes.
3. Depreciation.

Too frequently is the actual cash outlay regarded as the cost, no charge being made for the other sources of expense, though they may be often in excess of the assumed cost.

The value of irrigation will be the difference between the increased value of the crop per acre due to irrigation, and the cost of irrigation, included in which will be the cost of any additional farming operations made necessary by irrigation.

As has been pointed out, the value of irrigation is by no means confined to the actual direct value, but in many cases has greater indirect results in the upbuilding of the country, and of the industries to which it gives rise.

In arid countries the whole crop may be due to irrigation, without which nothing can be raised.

In semi-arid countries, irrigation, while not a necessity, may become a commercial necessity from the greatly increased values of the crops.

In humid climates, where the rainfall is usually well distributed, irrigation is of value only when the distribution is uneven. Where conditions are favorable and the irrigation development very cheap, it will undoubtedly pay to irrigate field crops, though expensive development would preclude such a thing. In the case of garden truck where the values of crops are very large, irrigation, even though very expensive, will pay for itself many times over. Crops of this nature are more sensitive to moisture requirements than more deep-rooted crops, and frequently a drought of a few weeks may result in the total failure of the crop. The increased yield of irrigated crops and the finer product often pay for themselves even in good years. Irrigation will also make the crop mature earlier when better prices may be obtained, and will frequently allow the growth of one crop per season more than can be grown on unirrigated land.

However, the actual area irrigated in humid climates is exceedingly small as compared with arid and semi-arid climates, and is confined to truck and also to meadow irrigation where

the water from small brooks is turned loose over the land for raising meadow grass.

In general it may be stated that valuable crops can hardly afford to be without irrigation in most climates, while crops of small value can be successfully irrigated only where water is cheap or where the climate is arid.

Certain crops are particularly sensitive to the needs of irrigation, such as strawberries, which require moisture especially during the three weeks while the fruit is maturing.

As an illustration of the value of irrigation, the following figures are taken from comparative tests on irrigated and unirrigated land at Beeville, Texas, in the semi-arid zone, and were made by Mr. J. K. Robertson, Superintendent of the State Experiment Station:

Red Bermuda onions planted 4.5 inches apart in rows 15 inches between centers.

COST OF FARMING 1 ACRE OF NON-IRRIGATED LAND.

Plowing and harrowing	\$2.00
Laying off furrows, — labor in irrigation before planting, etc.	2.00
Transplanting onions	9.00
Restirring with five-tooth cultivator	2.00
Water for irrigation before planting — 40,000 gals.	1.60
Eight cultivations	3.60
Hand weeding	5.00
Pulling onions 33.3 hours, at 7.5 cents	2.50
Trimming, sacking and weighing, 100 hours at 7.5 cents	7.50
Total	<u>\$35.20</u>

NOTE. — The land received one irrigation before planting.

COST OF FARMING 1 ACRE OF IRRIGATED LAND.

Plowing and harrowing	\$2.00
Laying off furrows and labor in irrigation before planting	2.00
Restirring	2.00
Transplanting	9.00
Water for irrigation before planting	1.60
Eight cultivations	3.60
Laying off rows for irrigation after planting	1.50
Four irrigations — water	6.70
Four irrigations — labor	4.80
Pulling, trimming, sacking and weighing 190 hours, at 7.5 cents	14.25
Total	<u>\$47.45</u>

Yield of non-irrigated land 19,075 lb., at 2 cents	\$381 .50
Profit	346 .30
Yield of irrigated land 38,056 lb., at 2 cents	\$761 .12
Profit	\$713 .67

NET GAIN BY IRRIGATION \$367 .37

In the calculations above, no allowance was made for the fixed charges of the irrigation pumping plant, which it would be, of course, impossible to figure for an experiment station. From corresponding stations, this would be, say, about \$17, leaving a total net profit of \$350 per acre, due to irrigation.

On the same farm irrigated cabbage yielded 17,632 pounds against 6144 pounds on unirrigated land. The cost of farming irrigated land was \$16.88 per acre against \$9.08 per acre for unirrigated land. At 2 cents per pound this gives a net profit of \$222 per acre for irrigated over unirrigated crops, and approximating fixed expenses this will still allow \$205 net gain due to irrigation.

The greatest part of the irrigated land is devoted to raising field crops, such as alfalfa, wheat, corn, etc., and crops like rice. Rice irrigation is, however, in a class by itself, requiring, as usually practiced, the complete submergence of the land. The values of these crops will usually lie between \$20 and \$80 per acre per year.

On pages 37 to 40 are given further data of the cost and value of irrigation in various parts of the country.

Irrigation should effect a uniform distribution of water over the land, to give the best results. However, this result is only approximated by the various methods in use. The cost of irrigation may in general be regarded as composed of two parts:

- (1) Cost of bringing the water to the land to be irrigated.
- (2) Cost of applying the water to the land.

If the supply of water is not limited, the most efficient irrigation would be the application of such a quantity of water that, for a given area, the net returns (that is, the difference between the value of the crop and the cost of irrigation plus the cost of farming) give the greatest interest on the investment. The size of the crop will in general increase with increasing quantities of water, rapidly at first, and then more gradually, until finally a maximum is reached, after which increased amounts of water will be a detriment. It will not pay to irri-

gate up to the point where the greatest crop is obtained, but irrigation should stop where the cost of additional irrigation exceeds the increased value of the crop resulting therefrom.

The periods between the application of irrigations (the irrigation frequency) will have an important effect on both the cost and results. The advisable frequency of irrigation depends on the soil, climate, nature of the crop, and method of irrigation. A deep soil, retentive of moisture with deep-rooted plants, will require less frequent irrigation than a shallow soil where the roots of the crop are nearer the surface.

Frequent irrigation has the effect of keeping the soil more nearly with the desired amount of moisture. However, on the other hand, the expense of frequent applications of water is greater than the expense of applying the same total quantity not so often. Also the application of small quantities of water is apt to be very inefficient, since a larger percentage will be lost by evaporation from the moist surface of the soil than would be the case were a greater depth applied. In a climate liable to sudden and heavy rains during the irrigation season it is advisable not to apply the water in too great amounts, since a rain following a heavy irrigation might do considerable damage from excessive moisture. Hence it is evident that the advisable amount of water to apply in irrigation and the advisable frequency of irrigation depend largely on the cost of irrigation and the value of the crop as well as on many other considerations, and that in general it will not pay to irrigate sufficiently to obtain the maximum crop. It is obvious, therefore, that irrigation is far from an exact science, and that it is natural to expect great variations in both the quantities of water applied and the frequency of application.

CHAPTER II.

UNITS IN USE.

THE following units of measurement are in use in irrigation practice.

The quantity of water applied per unit of land is usually expressed as the depth in feet or inches to which the land would be covered were the water evenly spread over it. This is referred to as the depth of irrigation.

Volumes of water are expressed in cubic feet, gallons, acre-feet and acre-inches, the acre-foot being the quantity of water contained in an acre 1 foot deep.

The flow of water is expressed in cubic feet per second (cu. ft. per sec.) and in gallons per minute (gal. per min.).

Capacities are often conveniently expressed in terms of the flow required to deliver the capacity in 24 hours. As approximations the following may be easily remembered: One cu. ft. per sec. = 450 gal. per min., and this flow will cover an acre 2 feet deep in 24 hours. Three acre-feet = 1,000,000 gallons.

Another unit commonly used is the miner's inch, the flow of water from a 1-inch square orifice under 4-inch water pressure above the center of the hole. This is, however, defined differently in different parts of the country in terms of an actual flow varying from about 10 to 13 gal. per min. It is now legally defined in California as a rate of flow of 1.5 cu. ft. per min., or 11.25 gal. per min.

The term "duty of water" is used in two different senses — as the number of acres a given flow in cu. ft. per sec. will irrigate, and as the annual depth of water applied by rain and irrigation to the land. Neither of these terms by themselves gives any information about the length of the irrigation season, or frequency of irrigation.

The annual depth of water (rain and irrigation) applied to the land cannot necessarily be used by itself as a criterion of the needs of irrigation. Unequal distribution of rainfall may lead

to erroneous conclusions if we admit such an assumption, particularly if the crop requires water at a time when there is no rain. In arid countries, where irrigation water is far in excess of rainfall, this may be a matter of small importance, but in a country of considerable rain it might become a matter of some moment. The annual depth of irrigation tells nothing about the length of the irrigation season, and hence of itself furnishes no measure, except in a general way, of the proportions of the plant and ditches which must be provided. The frequency of irrigation and the rate of supply of the water required per irrigation, on the contrary, furnish definite information as to these points.

A much more suitable basis upon which to make irrigation calculations is the following: Irrigation plants should in general be figured on a basis of supplying water at a rate sufficient to irrigate continuously all the desired land, provided there is no rainfall. This means that a certain continuous flow of water is required per acre, which may be conveniently reckoned in gal. per min. per acre. In order to obtain this figure, the frequency of irrigation and the depth per irrigation must be known. Dividing the gallons per acre by the time in minutes between irrigations, gives the required flow in gallons per minute. This is the quantity which can best serve as the basis for irrigation calculations and for the design of the proper size of plant. Multiplying the acreage by the required gal. per min. per acre gives the required gal. per min. of the plant, should it be operated continuously 24 hours a day. To find the proper capacity plant for shorter hours of operation, divide the required capacity given above by the percentage of the day it is desired to operate. To find the total quantity of water which must be applied per year, multiply the depth per irrigation by the number of irrigations per crop if the weather be dry. This gives the total depth of irrigation. Subtracting from this the rainfall during the irrigation season gives the approximate depth of water to be furnished by irrigation per crop.

If the maximum flow which must be furnished ran continuously through the year, it would cover the land to a certain depth. However, the water for irrigation will run only a comparatively small percentage of the time, and will cover the land to a much less depth. The ratio of the depth to which the land is irri-

gated to the depth of irrigation, were the actual flow to be continuous for a year, is known as the *irrigation factor*. The irrigation factor, which corresponds to the annual load-factor in power plants, is the percentage of the year the plant runs at full load. The nearer the actual flow approaches to the required flow, the higher the irrigation factor, provided the former is greater than the latter.

The method of calculation outlined applies in particular to places where water can be obtained, when required in a quantity sufficient for the irrigation of land. There are, however, many places where the water is limited in quantity, and where, when there is no storage, the available supply runs far short of the needs of the land during the irrigation season. In these cases it is impossible to attempt to use as a basis of calculation for the needs of the land for water, and irrigation is of necessity a compromise measure between what is most desirable and what can be obtained. Where the soil is deep and will allow the storage of water therein, it is not uncommon to apply heavy irrigations, when the water supply is available, to tide over the dry weather which may follow.

There is, however, such a large percentage of cases where suitable water supply is continuously available, that the plan of calculation outlined is of material assistance in the proper design of plants.

Tables I and II will greatly facilitate the calculation of irrigation plants. In Table I, column 1 is the duty of water in acres per cu. ft. per sec. which indicates the number of acres which a flow of 1 cu. ft. per sec. will irrigate; column 2, the required flow of water in gallons per minute per acre, represents the requirements of the land under existing conditions of water supply; columns 3 to 13 inclusive represent Q , the depth of irrigation to which the land would be covered were the flow provided in the corresponding line of column 2, to be applied for 24 hours per day for the number of days stated in the head of the appropriate column. The remaining columns of the table indicate the annual depth of water for irrigation for various irrigation factors given in the headings of the columns, the figures in the horizontal lines corresponding to the appropriate required flow in gallons per minute per acre.

Tables III to VIII are conversion tables for various units of

quantity and flow used in irrigation work. In order to abbreviate as much as possible, these tables have been given for only the nine units represented in the first column. To illustrate the use of the table, suppose that it were desired to ascertain the cubic feet per second flow which would deliver 92 acre-feet per day. Referring to Table III, 9 acre-ft. per day = 4.5374 cu. ft. per sec., hence 90 acre-ft. per day = 45.374 cu. ft. per sec., 2 acre-ft. per day = 1.0083 cu. ft. per sec. for a day. Hence 92 acre-ft. = 46.38 cu. ft. per sec. for a day.

To illustrate the use of Tables I and II, consider the problem of determining the size of plant to irrigate 200 acres to a depth of 2.55 inches every 12 days, the number of irrigations per year being 10. By Table II this requires a flow of 4.0 gal. per min. per acre, or 800 gal. per min., and will cover the land to a depth of 2.1 ft. per year, the irrigation factor being 33 per cent. If the plant be run only half the day, the required flow is 1600 gal. per min. and the irrigation factor 16 per cent. Should there be any unusual losses in seepage in bringing the water to the land, the flow should be correspondingly increased. The calculations and figures as given above, apply to one kind of crop, or at least to a crop requiring irrigation at one certain time of year at a certain rate. Provided it is desired to irrigate different kinds of crops which require water in different seasons of the year, the quantity of water to be supplied may be arrived at in one of two ways: either by making assumption of average values of the needs of the crops, or else by figuring each one out independently. The irrigation capacity which should be furnished will, of course, depend upon the manner in which the respective demands for water overlap. For example, if one crop requires water in the summer and fall, and another in the spring and summer, the capacity should, of course, be proportioned to the maximum demand, which would be in the summer.

TABLE I.
IRRIGATION DEPTH-DUTY.

Duty of water. Acres per cu. ft. per sec.	G Flow. Gals. per min. per acre	Q Depth of Irrigation in inches if applied for 24 hours every											
		7 days	8 days	9 days	10 days	12 days	15 days	20 days	30 days	40 days	50 days	60 days	
40	11.22	4.07	4.76	5.36	5.95	7.15	8.93	11.90	17.86	23.80	29.80	35.72	
50	8.98	3.34	3.81	4.28	4.76	5.71	7.14	9.52	14.28	19.04	23.80	28.56	
60	7.48	2.78	3.17	3.57	3.97	4.76	5.95	7.93	11.90	15.86	19.84	23.80	
70	6.42	2.38	2.72	3.06	3.40	4.08	5.11	6.80	10.21	13.60	17.02	20.42	
80	5.61	2.08	2.38	2.68	2.98	3.57	4.46	5.95	8.93	11.90	14.88	17.86	
90	4.99	1.86	2.12	2.38	2.65	3.17	3.97	5.29	7.94	10.58	13.22	15.88	
100	4.49	1.67	1.90	2.14	2.38	2.86	3.57	4.76	7.14	9.52	11.90	14.28	
120	3.74	1.39	1.58	1.78	1.98	2.38	2.97	3.97	5.95	7.94	9.93	11.90	
140	3.21	1.19	1.36	1.53	1.70	2.04	2.55	3.40	5.10	6.80	8.50	10.20	
160	2.80	1.04	1.18	1.33	1.48	1.78	2.23	2.97	4.45	5.94	7.42	8.90	
180	2.50	93	1.06	1.19	1.32	1.59	1.99	2.65	3.98	5.30	6.63	7.96	
200	2.25	84	96	1.07	1.19	1.43	1.79	2.39	3.58	4.78	5.97	7.16	
220	2.04	76	87	98	1.08	1.30	1.62	2.16	3.25	4.32	5.42	6.50	
240	1.87	70	79	89	99	1.19	1.49	1.98	2.98	3.96	4.97	5.96	
260	1.73	64	73	82	92	1.10	1.38	1.84	2.75	3.68	4.58	5.50	
280	1.60	59	68	76	85	1.02	1.27	1.70	2.55	3.40	4.25	5.10	
300	1.50	56	64	72	80	96	1.20	1.59	2.39	3.18	3.98	4.78	
350	1.28	48	54	61	68	82	1.02	1.36	2.04	2.72	3.30	4.08	
400	1.12	42	48	54	59	71	89	1.19	1.79	2.38	2.98	3.58	
450	1.00	37	42	48	53	64	80	1.06	1.59	2.12	2.65	3.18	
500	.90	33	38	43	48	57	72	.95	1.43	1.90	2.38	2.86	
550	.82	30	35	39	44	52	65	.87	1.30	1.74	2.17	2.60	
600	.75	28	32	36	40	48	60	.79	1.19	1.58	1.98	2.38	

Q = .05303 P G.
M = 1.614 F G.
P = Days between irrigations.
F = Irrigation factor.
M = Annual depth of irrigation in feet.

TABLE I—Continued.
M—ANNUAL DEPTH OF WATER IN FEET FOR IRRIGATION FACTORS.

Duty of water. Acres per cu. ft. per sec.	1.00	.90	.80	.70	.60	.50	.45	.40	.35	.30	.25	.20	.15	.10
40	18.12	16.30	14.49	12.68	10.86	9.06	8.15	7.24	6.34	5.43	4.53	3.62	2.72	1.81
50	14.49	13.05	11.58	10.14	8.69	7.25	6.52	5.79	5.07	4.35	3.87	2.90	2.17	1.45
60	12.07	10.87	9.65	8.45	7.23	6.03	5.44	4.82	4.23	3.62	3.02	2.41	1.81	1.20
70	10.35	9.32	8.28	7.24	6.22	5.17	4.66	4.14	3.62	3.11	2.59	2.07	1.55	1.03
80	9.05	8.15	7.24	6.34	5.42	4.53	4.07	3.62	3.17	2.71	2.26	1.81	1.36	.90
90	8.05	7.25	6.44	5.63	4.82	4.03	3.62	3.22	2.82	2.41	2.01	1.61	1.21	.80
100	7.25	6.52	5.79	5.07	4.34	3.63	3.26	2.90	2.54	2.17	1.81	1.45	1.09	.72
120	6.03	5.43	4.82	4.22	3.62	3.02	2.71	2.41	2.11	1.81	1.51	1.21	.91	.60
140	5.18	4.66	4.14	3.62	3.10	2.59	2.33	2.07	1.81	1.55	1.29	1.04	.78	.52
160	4.52	4.06	3.61	3.16	2.71	2.26	2.03	1.81	1.58	1.36	1.13	.90	.68	.45
180	4.03	3.63	3.22	2.82	2.42	2.02	1.82	1.61	1.41	1.21	1.01	.81	.60	.40
200	3.63	3.27	2.90	2.54	2.18	1.82	1.63	1.45	1.27	1.09	.91	.72	.54	.36
220	3.29	2.96	2.63	2.30	1.97	1.65	1.48	1.32	1.15	.99	.82	.66	.49	.33
240	3.02	2.72	2.41	2.11	1.81	1.51	1.36	1.20	1.06	.90	.76	.60	.45	.30
260	2.79	2.51	2.23	1.96	1.67	1.39	1.26	1.12	.98	.84	.70	.56	.42	.28
280	2.58	2.32	2.06	1.81	1.55	1.29	1.16	1.03	.90	.77	.65	.52	.39	.26
300	2.42	2.18	1.94	1.69	1.45	1.21	1.09	.97	.85	.73	.61	.48	.36	.24
350	2.07	1.86	1.65	1.45	1.24	1.03	.93	.82	.72	.62	.52	.41	.31	.21
400	1.81	1.63	1.45	1.27	1.09	.91	.82	.72	.63	.54	.45	.36	.27	.18
450	1.61	1.45	1.29	1.13	.97	.81	.73	.65	.56	.48	.40	.32	.24	.16
500	1.45	1.30	1.16	1.01	.87	.73	.65	.58	.51	.44	.36	.29	.22	.15
550	1.32	1.19	1.06	.92	.79	.66	.60	.53	.46	.40	.33	.26	.20	.13
600	1.21	1.09	.97	.85	.72	.61	.54	.48	.43	.36	.30	.24	.18	.12

TABLE II.

<i>G</i>		449	224	150	112	90	75	64	56	50
Duty of water. Acres per cu. ft. per sec.										
Required flow—gal. per min. per acre		1	2	3	4	5	6	7	8	9
<i>Q</i>	<i>days</i>									
	7	0.37	0.74	1.11	1.48	1.86	2.23	2.60	2.97	3.34
	8	0.42	0.85	1.27	1.70	2.12	2.55	2.97	3.39	3.82
	9	0.48	0.96	1.43	1.91	2.39	2.87	3.34	3.82	4.30
	10	0.53	1.06	1.59	2.12	2.65	3.18	3.71	4.24	4.78
	12	0.64	1.27	1.91	2.55	3.18	3.82	4.46	5.09	5.73
	15	0.80	1.59	2.38	3.18	3.98	4.78	5.58	6.37	7.17
	20	1.06	2.12	3.18	4.24	5.30	6.37	7.43	8.49	9.56
	30	1.59	3.19	4.78	6.37	7.96	9.55	11.14	12.72	14.32
	40	2.12	4.25	6.38	8.49	10.61	12.73	14.85	16.97	19.10
	50	2.65	5.31	7.96	10.60	13.26	15.92	18.56	21.21	23.87
60	3.18	6.37	9.56	12.72	15.91	19.10	22.28	25.47	28.64	
<i>M</i>	1.00	1.61	3.23	4.84	6.46	8.07	9.69	11.30	12.91	14.53
	.90	1.45	2.90	4.35	5.81	7.26	8.72	10.17	11.61	13.07
	.80	1.29	2.58	3.87	5.16	6.45	7.74	9.04	10.32	11.61
	.70	1.13	2.26	3.38	4.52	5.64	6.77	7.90	9.04	10.17
	.60	.97	1.94	2.90	3.87	4.84	5.80	6.77	7.74	8.72
	.50	.81	1.61	2.42	3.23	4.03	4.84	5.64	6.45	7.26
	.45	.73	1.45	2.18	2.90	3.63	4.35	5.08	5.82	6.54
	.40	.65	1.29	1.94	2.58	3.23	3.87	4.52	5.16	5.81
	.35	.56	1.13	1.69	2.26	2.82	3.39	3.95	4.52	5.09
	.30	.48	.97	1.45	1.94	2.42	2.90	3.38	3.87	4.35
	.25	.40	.81	1.21	1.61	2.02	2.42	2.82	3.23	3.63
.20	.32	.65	.97	1.29	1.61	1.94	2.26	2.58	2.90	
.15	.24	.48	.72	.97	1.21	1.45	1.69	1.94	2.18	
.10	.16	.32	.48	.65	.81	.97	1.13	1.29	1.45	

TABLE III.
ACRE-FEET CONVERSION TABLE.

Acre-ft.	Acre-in.	Cu. ft.	Gals.	Cu. ft. per sec. for a day	Gals. per min. for a day
1	12	43,560	325,880	.50416	226.29
2	24	87,120	651,760	1.0083	452.6
3	36	130,680	977,640	1.5125	678.9
4	48	174,240	1,303,520	2.0166	905.2
5	60	217,800	1,629,400	2.5208	1,131.5
6	72	261,360	1,955,280	3.0250	1,357.7
7	84	304,920	2,281,160	3.5292	1,584.0
8	96	348,480	2,607,040	4.0332	1,810.3
9	108	392,040	2,932,920	4.5374	2,036.6

TABLE IV.
ACRE-INCH CONVERSION TABLE.

Acre-in.	Acre-ft.	Cu. ft.	Gals.	Cu. ft. per sec. for a day	Gals. per min. for a day
1	.08333	3,630	27,157	.04201	18.858
2	.16667	7,260	54,314	.08403	37.72
3	.25000	10,890	81,470	.12604	56.58
4	.33333	14,520	108,627	.16805	75.43
5	.41667	18,150	135,784	.21007	94.29
6	.50000	21,780	162,940	.25208	113.15
7	.58333	25,410	190,099	.29409	132.01
8	.66667	29,040	217,254	.33611	150.86
9	.75000	32,670	244,410	.37812	169.72
10	.83333	36,300	271,567	.42013	188.58
11	.91667	39,930	298,724	.46215	207.44
12	1.00000	43,560	325,880	.50416	226.29

TABLE V.
CUBIC-FeET CONVERSION TABLE.

Cu. ft.	Gals.	Cu. ft. per sec. for a day	Gals. per min. for a day	Acre-ft.	Acre-in.
10,000	74,805	.11574	51.948	.22956	2.7548
20,000	149,610	.23148	103.90	.4591	5.510
30,000	224,415	.34722	155.85	.6887	8.265
40,000	299,220	.46296	207.79	.9182	11.019
50,000	374,025	.57870	259.74	1.1478	13.774
60,000	448,830	.69444	311.69	1.3774	16.529
70,000	523,635	.81018	363.64	1.6070	19.284
80,000	598,440	.92592	415.58	1.8365	22.038
90,000	673,245	1.4066	467.53	2.066	24.793

TABLE VI.
GALLONS CONVERSION TABLE.

Gals.	Cu. ft.	Acre-ft.	Acre-in.	Cu. ft. per sec. for a day	Gals. per min. for a day
100,000	13,368	.30689	3.6827	.15468	69.444
200,000	26,736	.6138	7.365	.3094	138.89
300,000	40,104	.9207	11.048	.4640	208.33
400,000	53,472	1.2276	14.731	.6187	277.78
500,000	66,840	1.5345	18.414	.7734	347.22
600,000	80,208	1.8413	22.096	.9279	416.66
700,000	93,576	2.1482	25.779	1.0826	486.11
800,000	106,944	2.4551	29.462	1.2374	555.55
900,000	120,312	2.7620	33.144	1.3921	624.99

TABLE VII.

CUBIC FEET PER SECOND FOR A DAY, CONVERSION TABLE.

Cu. ft. per sec. for a day	Gals. per min. for a day	Acre-ft.	Acre-in.	Cu. ft.	Gals.
1	448.83	1.9834	23.80	86,400	646,315
2	897.7	3.967	47.60	172,800	1,292,630
3	1,346.5	5.950	71.40	259,200	1,938,945
4	1,795.3	7.934	95.20	345,600	2,585,260
5	2,244.2	9.917	119.00	432,000	3,231,575
6	2,693.0	11.900	142.80	518,400	3,877,890
7	3,141.8	13.884	166.60	604,800	4,524,205
8	3,590.6	15.867	190.40	691,200	5,170,520
9	4,039.5	17.850	214.20	777,600	5,816,835

TABLE VIII.

GALLONS PER MINUTE FOR A DAY, CONVERSION TABLE.

Gals. per min. for a day	Cu. ft. per sec. for a day	Acre-ft.	Acre-in.	Cu. ft.	Gals.
100	.2228	.4419	5.303	19,250	144,000
200	.4456	.8838	10.606	38,500	288,000
300	.6684	1.3257	15.909	57,750	432,000
400	.8912	1.7676	21.212	77,000	576,000
500	1.1140	2.2095	26.515	96,250	720,000
600	1.3368	2.6514	31.818	115,500	864,000
700	1.5596	3.0933	37.121	134,750	1,008,000
800	1.7824	3.5352	42.424	154,000	1,152,000
900	2.0052	3.9771	47.727	173,250	1,296,000

CHAPTER III.

METHODS OF IRRIGATION IN USE.

BRIEFLY stated, the following are the methods of irrigation employed:

1. Flooding (the entire surface of the ground being wet).

(a) Land is divided into checks by contour lines from 3 inches to 10 inches vertical distance apart, and a small levee thrown up all around each check into which the water is admitted till the check is flooded.

(b) Bed system, where the land is divided by small levees into long rectangles, and water is admitted at the upper end at several places, passing over the land in a sheet.

(c) Contour ditch and tablet irrigation, where the water is admitted from cuts in the ditch bank and spread over the land. This requires considerable attention to make a uniform distribution.

(d) Wild flooding. Water is spread over large areas of land from a few outlets. This results in very unequal distribution.

2. Furrow system, where the water is admitted to furrows usually from 12 inches to 4 feet apart and flows through them, sinking into the ground and not wetting the entire surface.

3. Basin system, where the water is admitted to small basins or checks around trees. This system is used mainly for young trees.

4. Sprinkling by revolving water wheels or sprinklers, which are usually allowed to run in one place for from 1 to 2 hours.

5. Hand sprinkling from a hose.

In estimating the cost of applying water, there are two bases on which it can be figured:

1. Cost of applying 1 acre-foot.

2. Cost of irrigating 1 acre.

Provided the quantity of water it is desirable to apply is not exceeded, the first method gives preferable results in comparing

costs of application. Hence in this event the flow which one man can handle determines the efficiency of application.

Flooding by contour checks usually allows the handling of much larger streams per man than any other system if the ground slope is suitable. However, it usually necessitates the application of a greater depth of water than the other systems. A small flow of water cannot be used to advantage, since it results in a very wasteful and inefficient distribution.

The furrow system has a very important advantage over flooding or sprinkling systems of irrigation, in that the entire surface of the ground is not wet, resulting in less evaporation loss, in applying the water nearer the roots of the plants and in promoting deep rooting of plants, the roots reaching farther down where they are protected from the surface heat and can draw on the moisture deeper in the soil. If the soil bakes when wet, the furrow system should be used instead of flooding, and the furrows cultivated as soon as sufficiently dry, thus preventing baking, and keeping a fine protective mulch of earth over the moist earth, preventing rapid loss by evaporation.

However, the furrow system will not allow handling of as great quantities of water per man as flooding by contour checks, and will generally cost more for labor per unit quantity of water applied and per irrigation.

Sprinkling systems are employed mainly in the East, where the irrigated farms are very small. They are much used for truck.

The cost of sprinkling by revolving water-witches is independent of the depth, and is dependent only on the cost per irrigation for moving the apparatus.

Hand sprinkling is directly dependent on the quantity of water applied, and is very expensive. The stream handled by a man is small. Hence irrigation by this means is very light, in many cases not exceeding 0.25 inch. Such irrigation is very inefficient since a large percentage of water is lost by evaporation. It is better to apply one 1-inch, than four 0.25-inch irrigations. Hand sprinkling, however, has the advantage of allowing a light irrigation to be quickly given to a large area. From investigations by the author in Southern Texas and in the Eastern States the following information has been compiled as to irrigation practice along the lines laid down. This informa-

tion was obtained from a large number of plants, many of which, as might be expected, were radically different.

In irrigation by checks, the sizes of checks vary from 0.25 to 200 acres. The latter is many times too large, and is not to be recommended. It was used in the irrigation of rice. For other crops, checks usually vary from 0.25 to 10 acres, the proper size depending on the soil slope and flow of water available.

In bed irrigation the length of bed will vary between 100 and 700 feet, being usually from 100 to 250 feet long.

The width varies from 10 to 50 feet, usually lying between 10 and 20 feet.

The flow per bed varies from 200 to 1000 gal. per min., requiring between 3 and 20 minutes to pass over the bed.

3. Tablets vary from 300 to 1200 feet in length, and from 25 to 65 feet in width.

4. Furrows vary in length from 40 to 600 feet, and are run from 1 foot to 4 feet apart. It is usually good practice to run furrows from 100 to 300 feet long. If too long, the distribution of water is very uneven; and if too short, the labor of changing the water is too great. If the ground absorbs water rapidly, the furrows should be comparatively short; but if water sinks in slowly, they should be longer.

The time to run through the furrows varies between 5 and 500 minutes, usually varying between 15 and 150 minutes. Values of flow per furrow vary from 5 to 300 gal. per min. The best practice usually lies between 10 and 30 gal. per min. Too low a value of flow tends to effect an unequal distribution, and too great a value of flow will tear away the furrow. In orchard irrigation the water sometimes runs continuously in the furrows for two to three days. This information gives an approximate idea of the limits of irrigation practice for various methods of irrigation.

CHAPTER IV.

EVAPORATION.

THE efficiency of irrigation water may be measured by the actual useful work performed by a given quantity of water. To increase the efficiency, requires a careful investigation of the reasons for the loss of water. Evaporation is responsible for many of the greatest losses of water, both from reservoirs, and from the land itself. Evaporation consists in the absorption of water in the form of vapor by the air. It should not however be confused with the transpiration losses of plants, which while they may be included under the same general heading, have, as has been pointed out, important points of difference in the laws they follow.

The air is capable of containing in suspension a certain amount of moisture in the form of an invisible vapor. This quantity depends on the temperature, and increases rapidly with increase of temperature, as is shown in the following table.

WEIGHTS OF DRY AIR, AND OF THE MOISTURE OF SATURATION, PER CUBIC FOOT, AT PRESSURE OF 29.92 INCHES OF MERCURY.

Temperature. Degrees Fahr.	Weight of 1 cu. ft. of dry air, pound	Weight of vapor in 1 cu. ft. of saturated mixture, pound
0	0.0864	0.000079
32	0.0807	0.000304
52	0.0776	0.000627
62	0.0761	0.000881
72	0.0747	0.001221
82	0.0733	0.001667
92	0.0720	0.002250
102	0.0707	0.002997
112	0.0694	0.003946
122	0.0682	0.005142
132	0.0671	0.006639

When air contains its maximum amount of vapor, it is said to be saturated, and any diminution of temperature will result in a deposition of moisture from the air. From the table it appears that one cubic foot of air at 132° F. can hold 84 times as much moisture as at 0° F. When air which is not saturated is in contact with a moist surface, it will tend to absorb moisture therefrom. The actual rate of absorption or evaporation will depend not only on the percentage of saturation of the air, but also on the temperature of both the air, and of the surface, and in particular on their temperature just where they are in contact. The higher the temperature of either, other conditions remaining constant, the more rapid the evaporation. The important relation between the absorptive power of the air, and its temperature as given in the preceding table, is worthy of particular note, owing to the high evaporation losses in irrigation. Wind will greatly increase the evaporation due to the more intimate contact of the air and the moist surface, be it a water surface, or the surface of the ground. Thus, for example, different experimenters state that wind will increase the evaporation at percentages per mile of wind per day, varying between 0.5 per cent and 2 per cent. It is doubtful whether any such simple relation may be obtained between these two quantities, particularly in view of the wide divergence of the results. So many elements enter into the problem in practice that without ascertaining the effect of each one, it is difficult to reach satisfactory conclusions. The rapidity of evaporation is largely dependent on the dryness of the air. The condition of the air with reference to moisture is usually expressed as the per cent of humidity, *i.e.*, the per cent of saturation moisture the air contains. Thus it is evident that the evaporation is dependent on the six following conditions:

1. Area of the surface in contact with the air.
2. Temperature of the surface.
3. Temperature of the air.
4. Wind velocity.
5. Per cent humidity of the air.
6. Atmospheric pressure.

The temperature of the body is dependent on the amount of heat which it will receive, the amount of heat which it will transmit elsewhere, and on its ability to absorb heat. Excluding chemical changes and electrical manifestations, there are three

methods of the usual exchange, or transference of heat: — conduction, convection, and radiation.

Heat of conduction is heat which is transmitted through a body itself, or from one body to another. Heat of convection is heat which is carried away by transference to another body which is then transported; as for example, heat carried away by air currents. Heat of radiation is heat which is transmitted through the ether as radiant energy; such as the heat of the sun.

If equal quantities of heat be applied to equal weights of different bodies, then the rise in temperature will depend on the nature of the substance. Water has many times the heat storage capacity of most other substances, and hence will not rise nearly as much in temperature as other materials, under the similar conditions just outlined.

The radiant energy which a body can receive, or transmit, depends on the color, and the nature of the surface. Polished and light colored surfaces will reflect radiant energy, and will not absorb as much heat as dark surfaces. It is well known that light surfaces will not become as warm as dark surfaces when exposed to the sun. Hence the surface of the soil, when exposed to the sun, will become far hotter than a water surface under similar conditions, and if the soil surface be saturated with water, the loss by evaporation will be far greater than from the water surface. The reasons for this are fourfold:

1. The water will reflect a large amount of radiant energy which the soil will absorb.
2. The transmission of heat by conduction is greater in water than in the soil. The earth being a poor conductor of heat, the temperature effects due to the daily variation are confined to the surface layers, and are thus intensified at the surface.
3. The specific heat of water being greater than that of earth, the temperature rise of the earth will be greater than that of the water.
4. The irregular surface of the ground will allow a greater surface area in contact with the air, than is the case with water.

That these facts are true, is amply borne out by the results of experiments. Thus Professor Fortier in some experiments on evaporation found that under the conditions of the tests, the evaporation from a saturated soil was 2.5 times the rate of evaporation from water surfaces. The rate of evaporation from the

soil will of course vary greatly with the moisture in the top layer, decreasing rapidly as the soil becomes dryer. There are so many different elements entering into the rate of evaporation, that we must be careful not to apply experimental or other data to cases to which they do not belong. The results of both experiment and theory show that the rate of evaporation is directly dependent on the amount of moisture in the upper layer of soil, the temperature, the percentage humidity of the air, and the wind velocity.

It will be natural to expect a greater increase of temperature, and hence higher evaporation in the case of dark soils than in the case of light soils, due to the greater amounts of heat absorbed. This will undoubtedly be true provided the only physical difference between the light and dark soils consists in the color. There are, however, other elements which enter into the problem. Thus a soil which tends to crack open will facilitate evaporation. Some soils possess greater capillary power than others, and will tend to draw water to the surface. The top layer being kept moist will of necessity cause greater evaporation. This is notably true of alkali soils.

The dryer the top layer of soil, the less will be the evaporation loss. The moisture from below the surface, before evaporating, must first pass through the top layers, to which it is drawn by capillary action. Whatever circulation of air exists in the ground will also have some effect in assisting evaporation.

Heat will have the effect of increasing considerably this action. Hence the best way to conserve the moisture in the ground is to protect it both from heat, and from contact with the air, and not to wet the surface. Dry sand, or earth in a finely subdivided state is an excellent nonconductor of heat, owing in large part to the great multitude of air spaces between the particles. The air being practically confined has little opportunity to circulate, and to transmit heat by convection. A good mulch of dry earth will be very effective in preventing evaporation losses. Extensive experiments which have been made along these lines, have shown the great value of cultivation, not only for irrigated lands, but also to conserve the supply of moisture so necessary for dry farming.

The ground should be cultivated as soon as possible after irrigation, and in irrigating as little surface as possible should be

wet. This suggests that sub-irrigation by buried pipes would be the most efficient. This has been tried in a few instances, but as yet has proven rather impractical owing to the high first cost, and to the difficulty of effecting an equal distribution of water. The roots of the plants which are naturally lured to moisture, in time will clog up the openings in the pipes, and the pipes themselves. In some cases if the subsoil be deep and gravelly, much water may run to waste; also the distribution of water is apt to be uneven since water will percolate vertically more rapidly than horizontally.

From the standpoint of economy the deep furrow, *i.e.*, from 6 to 12 inches deep, will in many cases give the best results. There are, however, objections to deep furrows for some classes of work, owing to the increased cost of furrowing and cultivation, and because deep furrows may injure shallow-rooted trees. On the other hand, deep furrowing promotes deep rooting of trees, which will thus have a greater supply of both moisture and fertilizer from which to draw.

In bulletin No. 177 of the Office of Experiment Stations, United States Department of Agriculture, Professor Fortier gives the results of many interesting experiments to determine the loss of water by evaporation from the soil, which show in particular the importance of deep cultivation in conserving the supply of moisture in the ground. The roots of trees and plants will naturally spread where they can obtain moisture from the soil. In a wet season when the ground is kept moist by frequent rains, shallow rooting is encouraged, and when the upper layers of the soil become dry in the dry season, these roots are of no value, and will wither. Deep cultivation prevents the formation of roots in the surface soil, and makes them go further downwards, where they will be of use during dry seasons. Thorough and deep cultivation, through lessening evaporation, will prevent both the rise of injurious salts, and also the rise of those salts which are beneficial for vegetation, and the removal of the latter from the zone of the roots.

The following figures give a brief summary of some of Professor Fortier's experiments. The experiments on the evaporation from soils were conducted in tanks of two sizes, 23.5 inches in diameter and 47 inches deep, and 17 inches in diameter and 30 inches deep respectively, which were filled with earth and set

flush with the ground so as to imitate, as far as possible, the conditions of the rest of the soil. They were set inside other tanks provided with a water jacket to facilitate their removal for weighing.

The results of the experiments are the averages of a number of observations. Most of the experiments were conducted in Southern California during the summer and fall.

During the tests at Riverside the daily average temperatures reached a maximum of 93° F. at 1 P.M., and a minimum of 56° at 11 P.M. and 5 A.M. — a difference of 37°. The average difference between the 12-hour periods of day and night was 24°. At the depth in the ground of one foot, the daily temperature variations practically disappear. All temperatures hereafter will be given in Fahrenheit. While the temperatures of the air and soil approach each other during the early morning hours before the sun gets high, the soil in the sun at 1 P.M. had a temperature of 117°, while the air in the sun had a temperature of 82° at the same hour — a difference of 35° in the case of these experiments. From another series of experiments of nine weeks duration the following temperatures were obtained:

AVERAGE WEEKLY TEMPERATURES DURING THE DAY.

	Max.	Min.	Average
Soil in the sun	117	101	106
Air in the sun	90	76	84
Dry soil in the shade	88	77	83
Water in tank	82	78	79

Humid soil would not rise as high as dry soil, due to the greater specific heat, and to the greater power of conduction, as well as to the cooling effect due to evaporation. Still the increase of temperature over that of a water surface is ample to account for the effects of the greatly increased evaporation, as is shown in the following table. The soil was a sandy loam, and the temperatures were a mean of the morning, noon, and evening temperatures.

EVAPORATION FROM MOIST SOILS AND FROM WATER SURFACES.

Per cent free water	Temperature, Degrees Fahr.					Weekly Evaporation	
	Air in shade	Soil in shade	Soil in sun	Moist soil	Water surface	Soil inches	Water inches
Saturated	71	76	95	83	77	4.75	1.88
17.5	76	78	106	...	80	1.33	1.94
11.9	76	78	106	...	80	1.13	1.94
8.9	76	78	108	...	80	.88	1.94
4.8	76	78	108	...	80	.25	1.94

The evaporation from water surfaces is dependent on the temperature, wind and humidity, as appears from the following figures for two stations, Calexico and Chico. Calexico besides being hotter than Chico, is also much dryer.

EVAPORATION FROM WATER SURFACES.

	Chico	Calexico
Min. monthly water evaporation in inches	0.1	2.7
Max monthly water evaporation in inches	10.0	14.5
Annual water evaporation in inches	53	89
Max. temperature (monthly)	81	93
Min. temperature (monthly)	45	52

The following results were obtained by heating and cooling water in tanks in the field, and represent the average of four stations.

EFFECT OF WATER TEMPERATURE ON EVAPORATION FROM WATER SURFACES.

Average water surface, temperature	Average daily evaporation, inches	Average water surface, temperature	Average daily evaporation, inches
53.4	0.09	80.4	0.48
61.3	0.19	88.7	0.60
73.5	0.36		

With average wind velocities of from 2.4 to 4 miles per hour, and average water temperatures of 70°, the increased evaporation rate due to wind was about 0.5 per cent per mile of wind per day.

Experiments on soils conducted during several months in the dry season, where about two inches per month are applied to the ground, show that nearly all the water will evaporate, and that poor cultivation is of little value, and in many cases is positively detrimental. In a very sandy soil, where the water will drain through readily, poor cultivation is of some advantage, but in a soil which tends to retain the water nearer the surface, poor cultivation may cause greater evaporation losses than no cultivation.

Experiments lasting three months, which were conducted to show the relation between the quantity of water applied and the evaporation loss, show that the following equation holds true.

$$\text{Evaporation} = a + b \times (\text{the depth applied}),$$

where a , and b , are constants.

In the case of one test the initial free moisture was 7.7 per cent and was equivalent to 3 inches of water. Irrigation water was applied every two weeks, and the constants, a and b , at the end of three months were $a = 1.3$, $b = .66$. The total depth applied varied from 3.3 inches to 9.8 inches.

The effect of cultivation is shown in the following tables. Water was applied in 4-inch furrows, the duration of application being two days.

The average temperature during the day was 81°.

EFFECT OF CULTIVATION ON EVAPORATION.

	Evapora- tion inches	Water applied inches	Initial Moisture, per cent
Loss in inches in first 5 days un- cultivated	1.76	11.9	Top 12 inches dry
Loss in inches in next 6 days un- cultivated	1.39	...	6 per cent in balance of soil
Loss in corresponding period (6 days) cultivated	0.64	...	
Loss in inches in first 3 days un- cultivated	0.84	8.0	
Loss in inches in next 3 days un- cultivated	0.29	...	Top 4 inches dry
Loss in corresponding period (3 days) cultivated	0.10	...	3 per cent in balance of soil

The following table shows the effect of mulches in preventing evaporation, and is most instructive. 3.2 inches of water were applied, and after the water had sunk in, mulches of various depths were added.

Average temperature during the day was 90° F.

EFFECT OF MULCHES ON EVAPORATION.

	Evaporation in inches				
	First 3 days	Next 4 days	Next 4 days	Next 3 days	Total for 14 days
No mulch	0.43	0.19	0.08	0.02	0.72
4-in. mulch	0.13	0.03	0.03	0.02	0.21
8-in. mulch	0.04	0.01	0.02	0.01	0.08
10-in. mulch	0.01	0.00	0.01	0.00	0.02

The following table shows the effect of deep furrows in conserving the moisture in the ground. The ground contained 4.5 per cent of free moisture at the start, and 5.1 inches of water were added in two days, and on the third day the ground was cultivated.

EFFECT OF DEPTH OF FURROW ON EVAPORATION.

Average Temperature in the Shade, 82° F.

Depth of application	Losses in inches							
	Days. 1 and 2	3	4	5 and 6	7	8 and 9	10	Total
Surface	0.73	0.25	0.10	0.11	0.01	0.03	0.00	1.23
3-in. furrow	0.63	0.18	0.13	0.03	0.02	0.08	0.02	1.09
6-in. furrow	0.52	0.16	0.10	0.03	0.01	0.04	0.02	0.88
9-in. furrow	0.44	0.13	0.10	0.02	0.05	0.07	0.00	0.81
12-in. furrow	0.34	0.10	0.10	0.04	0.03	0.02	0.00	0.63

In another case where 2.1 inches of water were applied the loss in 34 days was 1.81 inches when using 3-inch furrows, and .49 inch when using 12-inch furrows. In these experiments the ground was cultivated as soon as it was dry.

To show the effect of sub-irrigation, water was applied to tanks at various depths. The free moisture in the ground at the start was equivalent to a depth of 4.4 inches, and a 2-inch mulch was

placed on top. 5.3 inches of water were applied. The evaporation losses in ten days were as follows, the average temperature during the day being 89° F. in the shade.

EVAPORATION FROM SUB-IRRIGATED SOILS.

Depth of application in inches	Loss in inches
3	1.34
6	0.96
9	0.55
12	0.32

Contrary to what might be expected, at the end of the ten days the moisture content near the surface was greater, the deeper the irrigation.

The following table shows the comparative evaporation losses for sub-irrigation at two feet depth, and for surface irrigation. 7.0 inches of water were added in four applications, a week apart.

SUB-IRRIGATION AND SURFACE-IRRIGATION EVAPORATION.

Kind of soil	Loss in inches in 26 days	
	Sub-irrigated	Surface irrigated
Sandy loam	0.74	4.22
Sandy soil	0.62	3.64
Dark loam	1.96	5.63
Average	1.11	4.49
Alkali soil	2.81	4.35

Thus in the case of sub-irrigation, only one-fourth of the water lost in surface evaporation was lost. The alkali soil was not included in the average, since alkali tends to keep the surface moist.

From the standpoint of economy of water, the best time to irrigate is at night, or in the evening. In many cases there are objections to night irrigation, since it is far more difficult to see properly than in the day time, and also since in the majority of cases, water must be used continuously where there is no reservoir for storing it.

The results of these experiments furnish important data on the quantitative values of evaporation losses, and show to what extent they may be avoided. They bring out with particular force the actual value of deep furrows, and of thorough cultivation. In practice the evaporation losses will be less than in the experiments, due to the effect of the crop in shading the soil. On the other hand, there will be a loss of water by seepage through the subsoil, which loss does not appear in the case of tests in tanks. It is a difficult matter to ascertain the actual evaporation losses in practice, and to segregate the transpiration and evaporation losses proper. The total losses from transpiration and evaporation may be easily arrived at by growing crops in the tanks. For further description of the work the reader is referred to Professor Fortier's bulletin.

In the Engineering News of Sept. 19, 1907, Professor Fortier gives the results of experiments made under his direction by Mr. Frank Adams to determine the influence of altitude on evaporation. The experiments were made on the Eastern slope of Mt. Whitney, California, in evaporation tanks. They show a steady decrease in evaporation, with increasing elevation. All the points when plotted, lie on a regular curve, with the exception of the results at the summit, where the much greater exposure resulted in higher losses. The fact that the losses decreased with increase of altitude is, without doubt, due to the lower temperatures, at higher elevations, which more than compensated for the increased evaporation which would result from lower atmospheric pressures. The following table gives a summary of the tests.

EVAPORATION FROM WATER SURFACES, ON MT. WHITNEY.

Station	Elevation	Weekly Evaporation
	Feet	Inches
Soldiers Camp	4,515	2.68
Junction South Fork and Lone Pine Creeks	7,125	2.04
Hunters Camp	8,370	1.75
Lone Pine Lake	10,000	1.63
Mexican Camp	12,000	1.60
Summit Mt. Whitney	14,502	1.67

CHAPTER V.

ACTUAL RESULTS OF IRRIGATION.

ACCORDING to Professor King,* the following are the average irrigation requirements of land in various parts of the world. The results were given in acres irrigated per cubic foot per second, but have been calculated also in gallons per minute per acre.

TABLE IX.

IRRIGATION PRACTICE IN VARIOUS PARTS OF THE WORLD.

Location	Acres per cu. ft. per sec.	Gal. per min.	Av. gal. per min.
North India	60 — 150	7.5 to 3.0	5.2
Italy	65 — 70	7.0 to 6.5	6.2
Colorado	80 — 120	5.6 to 3.7	4.6
Utah	60 — 120	7.5 to 3.7	5.6
Montana	80 — 100	5.6 to 4.5	5.0
Wyoming	70 — 90	6.4 to 5.0	5.7
Idaho	60 — 80	7.5 to 5.6	6.6
New Mexico	60 — 80	7.5 to 5.6	6.6
Southern Arizona	100 — 150	5.6 to 3.0	4.3
San Joaquin Valley	100 — 150	5.6 to 3.0	4.3
Southern California	150 — 300	3.0 to 1.5	2.3
Rice Irrigation	25 — 66	18.0 to 6.1	12.0

Professor King states that the amount of water required per irrigation to wet the land to a depth of 4 to 5 feet is from 2.5 inches to 4.5 inches for land fairly moist, and from 3.75 inches to 11 inches for land very dry. From 2 to 7 irrigations are required for wheat crops, the average usually being between 3 and 5. From experiments on earth tanks the following quantities of water must be applied to produce crops of one ton, the water so applied making up the evaporation and the transpiration losses of the crops:

* "Irrigation and Drainage," by F. H. King.

Crop.	Acre-in. per ton
Clover	5.1
Oats	4.4
Barley	4.1
Maize	2.4

The weight of one acre-inch of water is 113 tons.

As these tests were conducted in inclosures, sheltered from wind, this may be regarded as the minimum quantity of water to grow the crops without allowing for either probable surface loss or under-drainage, and, in general, considerably greater amounts must be applied to raise a crop. According to Professor King's figures it takes from about 300 to 500 pounds of water to raise 1 pound of dry material and provide for the transpiration and evaporation losses.

According to Newell, the average irrigation requirements are from 4 inches to 6 inches per month. This corresponds to a flow of from 2.5 to 3.8 gal. per min. per acre. In Southern California 1 cu. ft. per sec. will irrigate from 250 to 500 acres, a required flow of 1.8 to 0.9 gal. per min. per acre.

Great variations will be found in the depth of water applied per irrigation in different places. Very shallow irrigations are generally undesirable, on account of the cost of application and the inefficiency of the same, due to the high percentage of evaporation losses. On the other hand, too heavy irrigation results either in loss due to seepage of the water through the ground, or else in rendering the ground too wet, and hence unfit for the growth of plants. The suitable depth of irrigation will lie between these two extremes, and will depend, among other things, on the depth of soil, the pore space, and on the amount of moisture existing in the soil previous to irrigation.

The frequency of irrigation should be governed by the fact that moisture in the belt of soil which the roots penetrate, should not fall to a point where the crop would begin to show signs of failure, but should be kept in quantity sufficient for plant growth. Many plants, when the crop is maturing, require more moisture than at other stages in their growth.

While it is impossible to lay down hard and fast rules for irrigation practice, owing to the diverse conditions encountered, the figures which follow give a summary of investigations conducted by the author and show the irrigation practice in

various parts of the country. It is to be noted that the quantity "required flow" is not the actual rate of flow provided for, which is much greater, but is the rate which would be required were the required full water supply to run continuously during an irrigation season without rain. In many places the plants are far too large for the land they must irrigate, and in other cases the plants operate only during the daytime. Hence the required flow is much less than that actually provided in many places. In the figures to follow, two methods of obtaining averages are used: (1) Straight average, found by dividing the sum of the averages for the several farms by the number of farms; and (2) the weighted average, found by dividing the total results of all farms by the total size of the farms. These averages will be materially different, and the former will represent the average result of the individual farmer, while the latter represents the average result for the whole country.

Irrigation water is usually applied in depths varying from 0.25 inch to 8 inches per irrigation. The former is usually inefficient, due to large percentage evaporation; and the latter, unless the ground has a deep subsoil, is apt to prove injurious from over-saturation.

TABLE X.
IRRIGATION PRACTICE IN SOUTHERN TEXAS.

Crop	Frequency of irrigation, days	Irrigations per season	Depth of water per irrigation, inches	Depth of water per season, feet	Required flow, Gal. per min. per acre	Irrigation-factor, Per cent
Alfalfa	38	9	5.1	5.72	2.5	93
Cane	13	5	3.6	2.50	5.2	18
Corn	16	3	4.4	1.53	5.2	13
Cotton	21	3	5.5	1.60	5.0	17
Johnson grass	37	7	6.1	3.51	3.1	71
Onions	11	11	2.4	2.40	4.1	33
Rice	5.12	...	25
Sorghum	13	4	3.5	1.86	5.0	14
Truck	12	6	2.8	1.30	4.4	20
Average			4.2	2.67		

In general, it appears that efficient depths of irrigation per irrigation vary from 1 inch to 6 inches; the best depth depending

on the soil, crop, climate, and cost of water, as well as the cost of applying it.

In dry weather, truck is usually irrigated to a depth of from 1 to 2 inches, applied every 7 to 14 days.

Table X is taken in part from investigations by the writer in Texas, and allows for ditch losses. It is based on straight averages.

Owing to the widely varying conditions and practice of the different farms making up these tables, and to the method of obtaining averages, these results will not check exactly, and close results must not be expected. However, it may in general be stated as results that the average required flow per acre for grass or alfalfa is 2.8 gal. per min., and for rice is 12.3 gal. per min., while for other crops it is 4.9 gal. per min. These figures allow for loss in seepage in the distributing ditches. The actual required flow will vary with the nature of soil, climate, crop, and ditch loss. Considerable latitude in either direction must be allowed in applying these results to the various conditions in practice.

TABLE XI.
AVERAGE RETURNS FROM IRRIGATED CROPS IN SOUTHERN TEXAS.

Crops	Unit	Crop Yields	Assumed value per unit	Value of crop per acre
Alfalfa	Ton	5.9	\$15.00	\$88.50
Corn	Bushel	41.0	.50	20.50
Cotton	Bale	.8	50.00	40.00
Johnson grass	Ton	3.0	12.00	36.00
Onions	Pound	18612.0	.02	372.24
Rice	Pound	2140.0	.02	42.80
Sorghum	Ton	4.0		

TABLE XII.
AVERAGE COSTS OF APPLYING IRRIGATION WATER IN SOUTHERN TEXAS.

Cost of labor per day	\$0.59
Labor per irrigation per acre, in days42
Cost per irrigation per acre	\$0.31
Labor of irrigation per acre for a year, in days	3.07
Cost of irrigation per acre for a year	\$1.96

To the cost of applying water must be added the cost of supplying water.

The results from pumping plants are shown in Table XIII, giving total costs of pumping water per acre, using *weighted* averages.

TABLE XIII.
TOTAL COST PER ACRE OF PUMPING WATER
IN SOUTHERN TEXAS.

Fuel — wood —	
Rice irrigation	\$3.34
Other crops	12.04
Average	4.73
Coal-burning Plants	11.38
Average for Steam Plants	5.91
Gasoline Plants	17.46
Summary —	
Rice irrigation	4.87
Other crops	12.21
Total average	6.13

Rice irrigation plants usually operate under low lift, and are of large size.

These costs are greater than is usually expected, since the fixed expenses form from one-half to two-thirds of their total value.

The results from the small truck farms in the humid East show that on an average the value of irrigation is over \$200 an acre a year over the total cost thereof. The conditions encountered in humid countries are quite different from those in arid countries. Usually the only crops irrigated to any extent are truck, where the values of the crop are exceedingly high. Irrigation is of very great value, however, but owing to the small sizes of the farms and the methods of irrigation used, the cost is exceedingly high per unit quantity of water. The water is often distributed by piping at very high first costs and high cost of application. With pumping plants the loss in this piping involves pumping against a much higher head than would be necessary otherwise. Often city water is used. Tables XIV, XV, and XVI give average data on irrigation in the humid East, taken from several farms, where the conditions differed greatly.

TABLE XIV.

COST PER ACRE OF IRRIGATION IN THE EAST.

System	First cost	Annual cost of fuel and operation or of water	Fixed charges	Total	Annual depth inches
City water	\$44	\$16	\$9	\$25	4
Pump plants	74	9	15	24	8

COST OF WATER PER ACRE-FOOT.

City water \$48.
 Pump water (fuel and labor charges only) \$13.

TABLE XV.

COST OF APPLICATION OF WATER BASED ON LABOR
 AT \$1.50 PER DAY IN THE EAST.

System	Gal. per min. per unit stream	Cost per acre-foot	Cost per acre per irrigation	Depth per irrigation,—inches
Furrow	24	\$7.10	\$0.75	1.3
Hose	44	34.80	1.80	.6
Single sprinkler	4	34.40	1.12	.3
Multiple sprinkler	4	16.10	2.40	1.8

The cost of application per acre-foot is proportional to the size stream handled per man. Single and multiple sprinklers require only a part of the time of one or more men, while hose requires their entire time, costing far higher per unit quantity of water applied.

As indicating the possible field for irrigation of other crops in humid climates, Table XVI gives the average difference between crops in a good year, which irrigation would insure, and average crops in the East.

The results of investigations in the East show for truck a required flow per acre of 3.3 gal. per min. and give the following averages: Frequency, 6 days. Irrigations per crop per season, 5. Depth per crop, 5.6 inches. The frequency given would be required without rainfall. The required flow is to be contrasted

with 4.9 gal. per min. in Texas. The actual average flow provided in the East is 6.1 gal. per min. per acre, and as the plants are not usually operated at night, they are near the limit of irrigation.

TABLE XVI.
AVERAGE DIFFERENCE BETWEEN CROPS IN GOOD AND
AVERAGE YEAR PER ACRE IN THE EAST.

Crop	Unit	Av. yield per acre	Yield in wet year	Assumed price	Increased value in good year
Corn	bushel	48	64	\$0.60	\$14.40
Wheat	"	20	28	.83	6.64
Rye	"	20	25
Oats	"	40	52	.37	4.44
Tobacco	pounds	1330	1700	.08	29.60
Timothy	tons	1.6	2.1	13.00	6.50
Clover	"	1.6	2.1	11.00	5.50

In the East most of the distribution was by piping, resulting in no loss of water in the ditches; also the climate was not so warm as in Texas. Taking these facts into consideration, the results show a fairly close agreement. As has been shown, efficient irrigation consists in obtaining the maximum benefit from a given expenditure; and in the selection of the system of irrigation, the various component parts of the cost, and the actual effect of the same, should be considered as a whole as well as separately, before coming to a decision.

The relative costs of labor, fuel, and machinery have an important bearing on the system to be selected. No one element of cost should predominate to the detriment of the others. The length of irrigation season has a most important effect on the proper design. For a short season, with, say, an irrigation factor of from 10 to 20 per cent, generally the fixed charges will be greater than labor and operating charges. Where labor is high, it will not pay in general to adopt a system requiring excessive labor in the application of water to the land.

The low irrigation factors, which are quite common, suggest strongly in many cases the advisability of minimizing the first cost. In many instances this may be effected by the use of a reservoir or earth tank of small capacity, say sufficient to hold

12 to 24 hours' supply. The advantages of reservoirs for this purpose will be treated more fully farther on.

Where labor is high it is very undesirable to incur a large expense for application of water. The irrigator should have, if possible, as large a stream as he can handle to advantage, and not waste his time distributing small quantities of water. It is usually very wasteful to attempt to distribute from a pump, a small stream of water direct to the land. Not only is the seepage loss very high, but also the expense for labor for applying the water is far higher than should be the case were a reservoir to be used. Note particularly the cost of application of water in the East. Only the exceedingly high profits of irrigation allow such extravagant methods, where the cost of irrigation is often higher than the total value of irrigated crops in the West.

Truck irrigation in the East frequently saves an entire crop and may be worth as high as \$1500 an acre a year. It often enables an additional crop to be grown in a season.

From a number of plants in the East the average net return per acre per year from irrigated farms was \$1030, \$330 of which was due to irrigation, the total cost per acre of which lay between \$30 and \$100 per season.

CHAPTER VI.

DIFFERENT SOURCES OF WATER SUPPLY.

THE primary consideration in an irrigation plant is the source of water supply: First, with reference to obtaining the right to use it; second, whether the supply is sufficient for the needs of the land, when water is required; and third, the method and cost of development. The prior rights of other parties and the available supply of water should be carefully considered before going to the expense of actual construction. If the water be purchased from a water company, the nature of the contract should be carefully examined, to determine whether the applicant is likely to receive the necessary water supply, and the probability of the possible failure of the same. Before diverting water from a stream the proper state officials should be seen. The state engineer, or board of irrigation, usually has control of such matters in the West.

The Natural Flow of Streams.

The most common and most important source of irrigation water-supply consists in utilizing the natural flow of streams, by diverting water therefrom. Where the diversion of water can be made cheaply by the use of short canals, this is generally the cheapest and best source of supply, provided there is sufficient water in the streams when required for irrigation. The flow of the rivers and streams, however, occurs at such periods that without storage much of the water will go to waste, and cannot be used on the land. Where the development has exceeded the water supply, the water in the streams will often fail to furnish an adequate supply when most needed for irrigation. In these cases the land must get along as best it can without water.

Where the rights are determined by priority, the last comer is the first to suffer. Where the rights are vested in a canal com-

pany, the water is usually pro-rated to the various users. The flow of the streams and the probable variation of the same with the period of year, as well as the difference between different years, should be given careful consideration, with reference to the period of the irrigation season. Where the watershed is rugged and steep, the run-off of the rain water is usually very rapid. On the other hand, where the reverse conditions are found, the run-off will be much slower, much of the water finding its way gradually through the soil into the river bed, appearing in the form of springs, which tend to equalize the flow.

The melting snows, from which many of the rivers are fed, serve as a valuable source of water storage, preventing the rapid run-off which would otherwise occur. Of necessity a very large part of the supply of rivers used for irrigation will run to waste, unless the water be stored. This has led to the construction of many large reservoirs, and the important government work undertaken by the Reclamation Service will vastly increase the available irrigable area.

It is the intention of the government to deliver these dams and irrigating systems to the settlers, who are to pay for the work within ten years, after which they will be owned and controlled by themselves as a company. The construction of large reservoirs involving great sums of money usually calls for too heavy an expenditure to be undertaken by private individuals. Perhaps the most useful feature of the use of reservoirs in irrigation work is the fact that they render available water which could not otherwise be obtained; and indeed they are not governed by the previous cost of water, but rather ultimately by the actual value of the water. This will be discussed more fully farther on.

Reservoirs.

Reservoirs may be divided into two classes, natural and artificial. In the first class are included reservoirs where the greater part of the retaining banks are formed by nature; while, on the other hand, artificial reservoirs are those in which practically all the banks are constructed artificially.

Natural Reservoirs.

Natural Reservoirs are used for the storage of river or rain water, not only for its various economic uses, but also in some cases to equalize the flow of rivers and to minimize the danger of floods.

Preliminary considerations:

1. Before undertaking the construction of a reservoir a careful consideration should be given to the source and extent of water supply, drainage area, rainfall and distribution, the nature of the ground with reference to seepage and the annual and monthly evaporation. Among other considerations the nature of the soil with reference to salt and alkali should be taken into account, in order that the stored water may not be contaminated by dissolving the salts in the soil. A consideration of the losses by evaporation shows the importance of considerable average depth of water in the reservoir, as well as the poor policy of shallow construction. Efficiency, which is the ratio of the amount of water taken out to that which is put into the reservoir, should be determined beforehand as closely as possible. The efficiencies of reservoirs vary widely, depending largely on the climate, rainfall, and mean depth. In a good reservoir seepage losses should be small, the principal loss being from evaporation. The seepage losses in a reservoir will, in general, increase with increasing depths of water. Annual evaporation losses usually lie between 3 and 7 feet, in the arid West.

Evaporation tests are usually conducted by immersing a vessel filled with water in the center of a tank or reservoir. In order to protect against waves, the immersed vessel is surrounded by a bulkhead. Shielding the pan from the wind — which is necessary, however — will introduce an error in the results, as it is a well-known fact that evaporation is considerably higher on windy than on still days, owing to the more intimate contact between water and air. The surface area and the mean depth of a reservoir, as well as protection of the same from winds, have an important bearing on reservoir efficiency.

Elements of depreciation:

Reservoirs which are located in the bed of a water course are liable to damage from floods of special violence, and they are also subject to depreciation by the filling of the reservoir with

sediment carried down by the streams. Possible damage, owing to this, depends largely on the average annual amount of solid matter carried by the streams. A reservoir of small capacity with reference to the annual flow of the stream, if in the bed of the stream, will be damaged by the deposit of sediment to a larger relative extent than a larger reservoir under similar conditions. In many reservoirs arrangements have been made for flushing out the sediment, through scouring galleries.

Cost of Stored Water.

In estimating the value of water delivered by a reservoir, due attention should be given to the condition of the case, particularly to the element of depreciation.

Let	L = cost of land for reservoir,
	i = per cent interest and taxes,
	R = cost of reservoir construction,
	P = per cent fixed charges of reservoir,
	A = annual cost of attendance,
	W = cost of water supplied to reservoir,
	Y = acre-feet of water supplied to reservoir.
	E = reservoir efficiency.

Cost of stored water $W + Li + RP + A = X$.

Cost of stored water per acre-foot = $\frac{X}{YE}$.

Value of Location.

Usually the location of a natural reservoir is not a matter of choice, as it is dependent mainly upon the lay of the land. However, if it is possible to choose locations, the three following cases should be considered:

1. Reservoir in bed of stream.

Advantages: (a) It is not necessary to use a canal, or to construct means of diversion of river water.

(b) The entire supply of the river flows into the reservoir.

Disadvantages: (a) The reservoir being located in the bed of the stream, ample spillway must be provided.

(b) Unless the dam is made of masonry or other material

capable of serving as a spillway, it must be constructed to a sufficient height above the spillway to provide necessary safety.

(c) Possible damage by flood water.

(d) Sedimentation of reservoir.

(e) Owing to conditions encountered, it may be necessary to build expensive masonry dams.

2. Reservoirs near the source of supply not located directly in the river channel.

Advantages: (a) Reservoirs not subject to damage from excessive floods. Water supplied may be more easily controlled.

(b) Owing to this they allow of cheaper construction than reservoirs of the first class, since banks need not be built to such excessive height, and a smaller spillway will suffice.

(c) Sand traps may be provided in the supply ditch, thus keeping part of the sediment from entering the reservoir.

Disadvantages: (a) Diverting works and a canal must be built.

(b) In the event of a considerable rise in the stream from which the water supply is derived, water which in the first case could be stored were the reservoir not full, might in the second case be lost, owing to inability of the canal to carry the same.

3. Reservoirs located near the point of use of water.

Reservoirs of this description would have the advantage over reservoirs of the last-mentioned type, that a smaller capacity would serve the purpose, since it would be unnecessary to provide reservoir capacity to supply seepage loss of ditches necessary for class No. 2. On the other hand, they would necessitate the construction of larger ditches for conveying the water than would be necessary in case 2, since, aside from other considerations, the ditches in this case must carry sufficient water to allow for reservoir seepage and evaporation, and it would be advisable to provide ditches of sufficient size to carry water, much of which might otherwise be lost.

In many parts of the country no natural reservoir sites are available. In this event, to store water requires the construction of an artificial storage reservoir.

Except for very small capacities, the only practical form of reservoir consists of an earth tank or reservoir, usually constructed by throwing up banks to surround the same. Artificial reservoirs perform a most useful service in many cases, and

investigations show that they may be extended in many places to the storage of large quantities of water on a commercially profitable basis, indeed at an average cost less than the average cost of natural reservoirs.

Artificial Reservoirs.

Artificial reservoirs may be divided into two classes: (1) Those of small capacity, and (2) those of large capacity. A reservoir of small capacity is one that will store the discharge of a well pump or small stream for from half a day to a week, whereas reservoirs of large capacity will serve to store water for a considerable period. Small-capacity reservoirs are used particularly as a storage for pumped water or artesian-well water, and will serve the following purposes: (1) They will permit a continuous 24-hour operation of pumping plants or flow of wells without night irrigation, storing water during the night and irrigating with it during the day. (2) They will allow the use of irrigation heads larger than the rate of the supply to the reservoir, thus reducing the percentage of seepage losses in the distributing ditches. (3) The quantity of water which one man is capable of handling may be more easily supplied in this manner, thus reducing the cost of labor for irrigation. (4) They allow the operation of a pumping plant under full capacity and hence under conditions of highest efficiency at all times. Therefore, they may be a source of considerable saving in both fuel and labor charges. For example, if it is desired to irrigate a certain field, and only one-half the flow of the pump can be used to advantage, this water can be supplied either from what is stored in the reservoir without starting up the pump, or else the pump can be operated at its full capacity, delivering the water that is required to irrigate the field, and storing the remainder in the reservoir. (5) A small plant with reservoir may be installed to operate continuously in place of the installation of a larger plant operating only a portion of the time, thus cutting down the first cost of the plant, but increasing the cost of labor, in case it should be necessary to have an attendant always on hand. Small gasoline plants require very little attendance, and would benefit particularly in this event. This decrease in the capacity of the pump may have a very

important bearing on the fuel consumption in case the supply is derived from a well, due to the decreased head against which the water must be elevated. This head may be expressed by the formula $H = A + BQ + CQ^2$ (see page 86). Take, for instance, a case which came within the observation of the writer, where water was pumped from a well, the water level being 2 feet below the level of the ground. The water was hardly throttled at all in the ground itself, practically all the head against which the pump had to operate being caused by friction in the well casing. As the plant was run the pump had to operate against a head of 50 feet. The pump station was run only during the day. Providing the station had been operated all the day, delivering one-half the previous quantity of water, it would have required practically a head one-fourth of that which it did require, thus necessitating a power plant only one-eighth of the size, and reducing very materially both the first cost of the plant and the running expenses, although the cost of labor would have been increased. The saving in fuel, however, would have far more than compensated for the additional labor, not to mention the saving in fixed expenses.

Considerations which can be urged against reservoir construction are: (1) First cost. (2) The land occupied. (3) Additional height to which water must be raised in order to fill the reservoir. (4) Seepage and evaporation. If the material for the construction of the reservoir is at all suitable, proper construction should largely eliminate seepage. With small reservoirs, seepage and evaporation should be of little importance. While all stages of reservoirs of intermediate capacity may be built, yet in general the most useful sizes would be reservoirs holding from 12 hours to a week's pump or well capacity, or else reservoirs of large size retaining the water for long periods except where the supply is pumped by windmills, and hence has to depend on an uncertain source of power.

Canals as Storage Basins.

It is frequently necessary to supply from pumping plants a flow of water considerably less than the normal supply of the pumps. In cases of this nature the storage of water pumped is a very useful feature. In some cases canals have been made

sufficiently large to answer this purpose. However, generally speaking, the use of a canal for a storage basin is not to be looked on with favor, for the following reasons: (1) In proportion to the volume stored it presents a large surface for seepage. (2) In comparison with a reservoir proper, the bank is much longer than the corresponding reservoir bank, and usually not so strongly built. A break in the canal bank where a large amount of water is stored is liable to do considerable damage to adjoining land. (3) In comparison with reservoirs of equal storage capacity, the cost of the canal banks would be excessive as compared with cost of reservoir bank. (4) To avoid unnecessary waste of water and loss of time in reaching the lands to be irrigated, it is desirable that canals should not have too large capacity. In places where canals are used as storage basins, the construction is usually of such a nature that in order to raise the water to sufficient height to irrigate certain sections of the field the canal must be filled completely. Where storage basins are desired it would be decidedly preferable to construct reservoirs for such purpose, and to build the canals of sufficient capacity to convey the water to the land without velocity sufficiently great to erode the banks. They should, however, be built with banks sufficiently strong, which should be at a safe elevation above high-water mark in the canal. Any amount of trouble and annoyance in irrigation is caused by flimsily constructed canal banks when the water is run dangerously close to the top and is constantly breaking through.

Underground Supply.

Perhaps the greatest number of irrigation plants derive their water from the underground water supply by means of wells. The underground supply has the very important advantage that it can be tapped usually at the point of use, thus doing away with the necessity of long conduits with their inevitable losses and high cost.

The earth is composed of various strata which usually form planes more or less continuous over large areas. These strata may be classified with reference to the resistance they offer to the passage of water, some of them transmitting water readily, while others are quite impervious. The underground waters

flow through certain strata or channels. It is the exception, however, when they flow in open subterranean channels, by far the greatest part of the flow being through porous strata of sand, sandstone, or gravel. The resistance to flow through the water strata is so great that the movement is usually very gradual, and the flow, instead of being confined in a small channel, often fills the entire stratum. The formation of the earth is such that the ground is divided into water strata which are more or less independent of each other, depending on the imperviousness of the intervening strata. Each water stratum receives the seepage into the catchment area of the stratum, or from direct connection with or leakage from other strata. Fig. 2 illustrates the general principle of water distribution into various strata, the figure representing a profile and section of the land; the



Figs. 2 and 3. Water Distribution in Strata.

various water strata, *a*, *b*, and *c*, being fed respectively from the surface seepage from *A*, *B*, and *C* alone, provided the intervening strata are impervious. If the flow of water in a water-bearing stratum is sufficiently great just to saturate the entire stratum at any point, then if this stratum be tapped by a well the water will rise in the well to the level of the top of the stratum. Should the flow increase, water will be under pressure in the stratum, and will rise in the well to a higher level. Should the pressure be sufficiently great to raise the water above the ground level, the well, if an opening be made in its casing at the ground, will give forth an artesian flow.

It is, of course, not necessary to have a flow through the ground strata for the water level to be raised to a sufficient height to be under pressure, as is seen in Fig. 3.

The water-bearing strata of the earth form natural reservoirs of vast extent. Sandy soils will contain from 25 to 40 per cent of their total volume in storage capacity, and in consideration of their enormous extent it is evident that the underground storage reservoirs are of far greater extent than all the surface

reservoirs which will ever be constructed. The underground water comes directly from seepage through the surface of the soil. The rainfall and seepage from rivers and canals and from irrigated land are the main sources of its supply. Unlike the surface storage reservoirs, the greater part of the underground water is in continual motion, but the retarding effect of the soil is so great that it forms a strong tendency to equalize the flow. The seepage through the soil forms an important source of supply of most rivers, reappearing in the form of springs, and in some places coming out under the ocean.

The rate of movement of underground waters varies directly with the head or pressure causing the flow in a given distance. The nature of the soil has also a most important effect on the flow. The more open the soil, the greater the flow; while the finer the grains of the soil, the less the flow. Gravel transmits water readily, coarse sand fairly well, fine sand slowly, while sand with clay in it offers a great resistance to the flow of water. In limestone formations the water is often found in caverns in the rock, frequently flowing as a subterranean river. In general, the more free the nature of the water-bearing strata, the greater is the likelihood of obtaining large supplies therefrom, while from poor strata the supply is likely to be much restricted. The source and extent of the water which goes to make up the underground supply should be carefully considered before attempting extensive development. The seepage into a stratum is dependent on the catchment area of that stratum, the rainfall, evaporation and surface run-off of the land. Return seepage from irrigated lands may form an important addition to the underground supply, as is evidenced by the return seepage to the North Platte River from the irrigated lands near by. This is described at length in bulletin No. 157 of the Office of Experiment Stations of the United States Department of Agriculture.

The subject of the flow of underground water is treated at length by Professor Slichter in investigations of the United States Geological Survey. The resistance of a porous medium to the flow of water is dependent on the size of grains and on their arrangement. The larger the grains, the less the resistance. If, however, large and small grains be mixed together, the small grains will fill the spaces between the large grains, causing the resistance to increase much beyond that of sand having grains

TABLE XVII.
TRANSMISSION CONSTANTS GIVING THE VELOCITY OF FLOW THROUGH WATER SANDS OF
VARIOUS EFFECTIVE SIZES OF GRAIN.

Table computed for 60° F. Results for other temperatures can be found by the use of the next table.

Effective diameter of soil grain in mm.	Porosity.					Kind of soil.	
	80 Per cent.	82 Per cent.	84 Per cent.	86 Per cent.	88 Per cent.		90 Per cent.
0 .01	0 .000033	0 .000040	0 .000050	0 .000060	0 .000072	0 .000095	Silt.
.02	.000131	.000162	.000198	.000250	.000286	.000330	
.03	.000280	.000364	.000440	.000538	.000645	.000763	
.04	.000527	.000648	.000790	.000958	.001145	.001355	Very fine sand.
.05	.000822	.001012	.001240	.001505	.001790	.002120	
.06	.001182	.001458	.001784	.002180	.002580	.003050	
.07	.001610	.001983	.002430	.002950	.003510	.004155	Fine sand.
.08	.002105	.002590	.003175	.003825	.004585	.005425	
.09	.002680	.003280	.003918	.004615	.005390	.006240	
.10	.003282	.004050	.004860	.005740	.006710	.007760	
.12	.004725	.005830	.007130	.008620	.01032	.01220	
.14	.006430	.007940	.009720	.01172	.01404	.01662	
.15	.007380	.009120	.01115	.01345	.01611	.01910	
.16	.008410	.01036	.01268	.01531	.01835	.02170	
.18	.01064	.01311	.01605	.01940	.02320	.02745	
.20	.01315	.01620	.01983	.02390	.02865	.03390	

.25	.02050	.02530	.03100	.03740	.04480	.05300	
.30	.02860	.03640	.04460	.05380	.06450	.07630	Medium sand.
.35	.04025	.04960	.06075	.07330	.08790	.01039	
.40	.05270	.06480	.07940	.09575	.1145	.1355	
.45	.06650	.08200	.1005	.1211	.1450	.1718	
.50	.08220	.1012	.1240	.1495	.1780	.2120	
.55	.09940	.1225	.1500	.1810	.2165	.2565	
.60	.1182	.1458	.1784	.2150	.2580	.3050	
.65	.1390	.1710	.2095	.2530	.3030	.3580	Coarse sand.
.70	.1610	.1983	.2430	.2930	.3510	.4155	
.75	.1850	.2278	.2785	.3365	.4030	.4770	
.80	.2105	.2590	.3175	.3825	.4585	.5425	
.85	.2375	.2925	.3580	.4325	.5175	.6125	
.90	.2660	.3280	.4018	.4845	.5800	.6860	
.95	.2965	.3650	.4470	.5400	.6460	.7650	
1.00	.3282	.4050	.4960	.5980	.7170	.8480	
2.00	1.315	1.620	1.983	2.390	2.865	3.390	Fine Gravel.
3.00	2.960	3.640	4.460	5.380	6.450	7.630	
4.00	5.270	6.480	7.940	9.575	11.45	13.55	
5.00	8.220	10.12	12.40	14.95	17.90	21.20	

of the average size. The result of such a mixture will cause the resistance to be equal to the resistance of a sand with uniform grains still smaller in size. The size grains giving the equivalent effect is known as the effective size.

Measurements on the resistance of sand to flow are usually made in the laboratory by what is known as the aspirator. The sand is first dried, and then air is forced through a standard sized tube of sand. From the relation between the pressure of air and the flow, the resistance to the flow of water can be deduced.

Table XVII, taken from Water Supply and Irrigation Paper No. 140 by the United States Geological Survey by Charles S. Schlichter, gives information as to the pressure necessary to force water through soils with various size grains.

Temperature °F.	Relative flow Per cent	Temperature °F.	Relative flow Per cent
32	0.64	70	1.15
35	0.67	75	1.23
40	0.73	80	1.30
45	0.80	85	1.39
50	0.86	90	1.47
55	0.93	95	1.55
60	1.00	100	1.64
65	1.08		

It is to be noted that the resistance to flow varies greatly with the temperature. The porosity given in the table represents the percentage of void space in the sand, and the figures show that the arrangement of sand grains has a most important effect on the transmission of water. If the sand is tightly packed it will offer a far higher resistance to flow than that of loosely packed sand of the same effective size of grain.

The transmission constant given in the table represents the cubic feet of water per minute which a column of sand, 1 foot square and 1 foot long, will transmit under a difference of head at the ends of 1 foot of water.

CHAPTER VII.

METHODS AND APPLIANCES FOR OBTAINING WATER.

HAVING decided on the source of supply and the quantity of water, the next question which confronts the irrigator is how will he be able to obtain the water in a position where he can utilize it on the land, and what structures will be needed for the work. The water must be delivered at a place or places sufficiently high to irrigate all the land by gravity. In a very limited number of cases, water is delivered under pressure and distributed by a piping system, but, as a general rule, water is distributed by gravity alone.

Conduction and Distribution of Water.

Having selected the location where the water is to be delivered, the next problem is how to get it there. For obtaining water from streams or reservoirs, the structure most commonly employed is the canal. The usual method of constructing a canal is by excavation, the dirt which is thrown out forming part of the bank. The water level is usually not run higher than the natural surface of the ground before excavation, but if it is desired to use the artificial banks for holding water, they must be made comparatively water tight, and after vegetation has been removed, the ground at the banks should be plowed to insure a union between the old and the new ground. Sometimes the entire banks are constructed artificially, but it is usually desirable to have the water-carrying part of the canal in the natural ground. The water in a canal should not be run too close to the top, but a safe margin should be allowed to provide for the inevitable variations in water surface and the effect of wind. Where the canal runs through porous strata, it should be lined to prevent serious seepage losses. The materials usually employed for such a purpose are cement, clay, or puddle, which is a mixture of clay, gravel, and sand. Cement

is usually the most expensive lining, but will practically prevent seepage loss. Before lining with cement, the sides and bottom should be thoroughly compacted to obviate settlement and cracking. Canal banks should not be run to a point on top, but a safe width of bank should be allowed. Also the slope of the banks should not be so great as to cause danger of caving. In the best construction the canal linings are constructed with rock or concrete, which is then covered with a cement mortar; but in some cases where the banks are sufficiently firm, the cement mortar is directly applied thereto. The cross-section of the canal should be sufficient to carry the water without too high a velocity. In earth the best velocity is between 2 and 2.5 ft. per sec. A higher velocity is apt to erode the banks, and a lower velocity will allow the deposition of sediment and the growth of weeds and vegetation which must subsequently be removed. The velocity of water in a canal is dependent on the wetted surface, the cross section of the water, the slope of the canal, and the nature of the material composing the banks.

In a given case where the section and wetted surface are determined, the desired velocity may be obtained by running the canal on the proper slope. The bottom of a canal should be run on a uniform slope determined accordingly.

The line of the canal should be laid out running back from the point at which water is to be delivered, to the source of supply, by the shortest and most practical route; the line rising in elevation according to the determined slope, and avoiding, wherever possible, cuts or depressions.

In case a steeper grade than that selected is desirable, to shorten the route or for other purposes, the additional fall in the canal must be taken care of in order not to cause too high velocities. The usual method of accomplishing this result is by the use of *drops*. In this way small artificial falls are inserted in the canal for stepping down from one level to another. The canal is then run on the desired grade. The drops are usually provided with adjustable flashboards for varying the level of the water in the different sections of canal, or for preventing the water from flowing past the sections where it is desired to be used. The drops are constructed with a foundation for taking care of the impact of the falling water and preventing erosion. Where made of timber and

located on alluvial soil, they are frequently constructed by driving two rows of sheet piling across the canal. Stringers are attached to the top of the same, on which a flooring is run, the level of the flooring being even with the bottom of the outgoing canal. On the flooring is constructed a framework supporting sheet boarding run across the canal, either in a vertical plane, or with the upper side inclined down stream. This is provided with a superstructure and removable flashboards, and wings are carried well into each bank to pre-

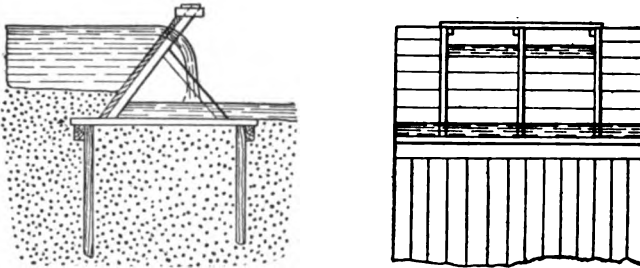

Fig. 4. Timber Drops on Soft Soil.

vent the structure from washing out. The impact of the falling water is taken on the timber flooring (see Fig. 4).

Where it is necessary to carry the water across draws or depressions, it may be accomplished by any of the following methods:

1. Flume.
2. Earth embankment.
3. Inverted siphon.

Flumes are usually constructed of timber, and are used also for conveying the water where the ground is treacherous and liable to excessive seepage, as well as in places where ditch construction is expensive or impractical, such as along vertical cliffs, etc.

Wooden flumes should always be kept wet where practicable, since alternate wetting and drying of the timber leads to rotting of the wood, distortion and shrinkage, and consequent leaks. The life of wooden flumes where not kept filled with water is of necessity short, but often wood is the only available material. Concrete, and particularly reinforced concrete, while higher in

first cost than timber, will often give far more desirable structures, with a much smaller cost for maintenance. The use of concrete for such purposes is increasing, as its advantages are better appreciated, but often the financial condition of irrigation companies when first organized, will not allow the use of more expensive types of construction. For carrying the flume across depressions, wooden trestles and supports are commonly used, though sometimes steel is used for this purpose. The flume must be carried on suitable grade to discharge the desired quantity of water. The velocities employed in flumes are considerably higher than are used in earth ditches, usually varying from 5 to 10 ft. per sec. They are limited only by the available head and by the erosive action of water on the material of the flume. The higher the velocity, the smaller and cheaper the flume. The change of velocity in going from the ditch to the flume and vice versa, should be made gradually by tapering the entrance to the flume and the discharge therefrom, and all the structures at entrance and exit must extend sufficiently far not to allow the higher velocities to act on materials liable to erosion.

Wooden flumes are usually constructed of timber, the bottom and sides being tongue-and-groove or ship-lapped to make them

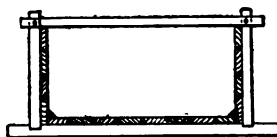

Fig. 5. Wooden Flume Construction.

tight. Where the sides and bottom join, a triangular batten is nailed to the inside, and the joints covered with pitch or asphalt to make them hold water (see Fig. 5).

Where earth embankments are used to carry the water across depressions, there will be at first considerable settlement and leakage until the material is finally compacted.

Where cement or concrete lining is used for carrying the water over such embankments, the latter should first be thoroughly compacted before the lining or conduit is put in place. If the embankment is across a draw, provision must be

made for carrying off the rain water which discharges into the draw, by suitable culverts or conduits under the embankment.

Inverted siphons are commonly used for conveying the water across depressions. An inverted siphon consists of a pipe or pipes or a closed conduit, with suitable intake and outlet, where the intake and outlet are higher than other parts of the pipe, and consequently the remainder of the pipe is under pressure. The discharge end must be placed at an elevation sufficiently below the entrance, for the difference in elevations to overcome the friction losses in flowing through the pipe. Velocities of 6 to 10 ft. per sec. are commonly used for such work. The intake and outlet should be so constructed as to give a gradual change in the velocities of the water between canal and siphon.

TABLE XVIII.

THE APPROXIMATE COST OF REDWOOD PIPE IN CALIFORNIA.

Inside diam. of pipe, inches	Cost of pipe per foot for heads				
	0 to 20	20 to 30	30 to 40	40 to 50	For each additional 10 feet head
12	\$0 .38	\$0 .40	\$0 .42	\$0 .45	\$0 .03½
14	.44	.46	.48	.51	.04
16	.52	.54	.57	.60	.04½
18	.57	.60	.63	.66	.05
24	.98	1 .02	1 .06	1 .11	.07½
30	1 .24	1 .29	1 .34	1 .40	.09
36	1 .46	1 .53	1 .60	1 .68	.12
48	1 .95	2 .08	2 .22	2 .36	.18
60	3 .73	3 .96	4 .19	4 .43	.35
72	4 .57	4 .90	5 .23	5 .57	.41
84	6 .85	7 .31	7 .78	8 .25	.64
96	8 .00	8 .56	9 .17	9 .70	.80
108	9 .00	9 .88	10 .76	11 .65	1 .06
120	10 .30	11 .15	12 .00	12 .85	1 .17

Where distances and pressures are small, such as for crossing under a road, wooden boxes are frequently used. The materials generally utilized for conduits are riveted steel pipe, wooden pipe, or reinforced concrete pipe. The two latter are usually employed only in large sizes. Wooden pipe is constructed of staves running longitudinally, which are bound together by

round iron bands, provided with adjustable nuts for tightening them. Where the end joints occur, sheet-steel tongues are inserted to make them water tight, but the longitudinal joints are kept tight by the pressure exerted by the bands.

Wooden pipe when properly installed is subject to very little depreciation. It should be set in such a manner that the entire inner surface will always be kept wet. Manufacturers of wooden pipe claim that redwood pipe under good conditions should last fifty years, and even under quite unfavorable conditions at least twenty-five years. This would give an average annual depreciation rate of 3 per cent. Pipe built of pine is subject to much more rapid depreciation, its life being approximately fifteen years under similar conditions, which would signify a 7 per cent depreciation. Experience with wooden pipe leads to the conclusion that a pipe not buried will last longer than one which is buried only a few inches to a foot below the surface of the ground, due to the action of roots and brush on the wood. The life of pipe may be much prolonged by burying the top at least 5 feet below the surface. Exposed wooden pipe is more liable to damage by fire or maliciously inclined people than were it covered with earth.

One great advantage of wooden pipe over metal is the increased carrying capacity due to the smoothness of the wood. Thus, for example, wooden pipe will carry approximately 16 per cent more water than the same size iron pipe for a given loss of head, owing to the greatly diminished friction.

Reinforced concrete pipe is used in large sizes, the concrete being usually from 6 inches to 10 inches thick, depending on the size of pipe. The reinforcement consists of either expanded metal or plain iron bars bedded in the concrete. If bars are used, they should be run not only around the pipe but also longitudinally. Fig. 10 shows the general form of sections of reinforced pipe. Where any quantity of such pipe is to be laid, the inside forms may be made collapsible and pulled along inside the pipe, thus making a material saving in the cost of construction. Experience has shown the value of concrete pipe under low pressures, but experiments made under the direction of the Geological Survey, under moderate and high pressures, apparently indicate that the pipe is not all reliable, owing to leakage through the concrete. Possibly in practice,

the silt in the water would seal up such leaks, but this has not been demonstrated as yet.

In conveying the water from a stream to the land to be irrigated, the bottom of the canal in general must be on a slope less than the slope of the river, in order to elevate the water sufficiently. For example, if the stream slopes 10 feet in a mile, and the canal be run on a slope of 2 feet per mile, it will rise 8 feet



Fig. 6. Laying Wooden Pipe.

above the water level of the stream in a mile; and if the point from which the water is to be distributed over the land is 16 feet above the stream level at the nearest point, the canal must be two miles long to where it strikes the river, unless the level of the latter be raised by a dam or weir.

By placing such a structure in the river the water level may

be raised and the canal length shortened. Such structures in general must allow the total flow of the river to pass over them or through suitable spillways, without damage or danger. They are often provided with flashboards for raising the

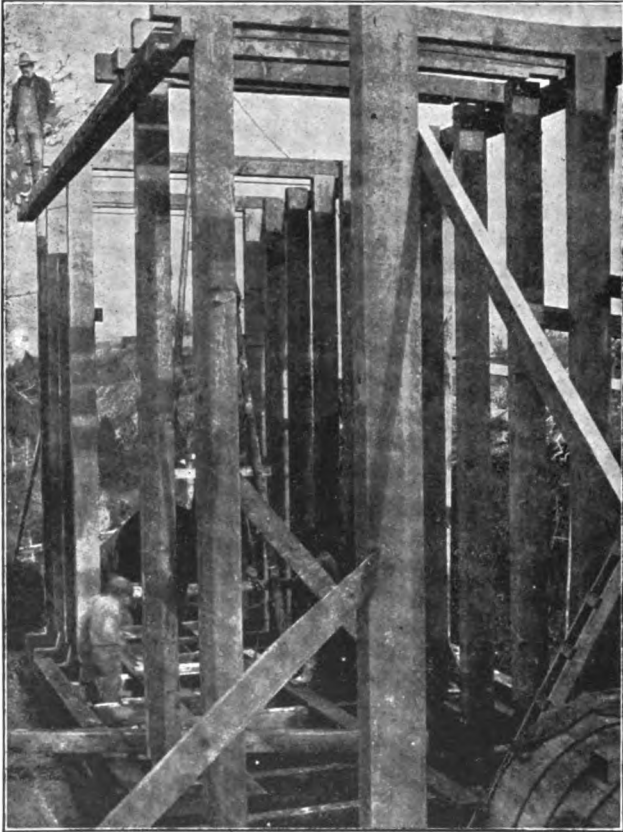

Fig. 7. Laying Wooden Pipe.

water level when desired, which are taken away to allow the flood waters to pass over the crest with safety to the structure and without danger from raising the water level too high.

Water from the stream is admitted to a canal through a suitable form of head gate, which controls the flow. The

head gate may consist of one or more adjustable gates guided vertically, driven by a screw or rack and pinion, and guided in suitable ways, or else may be constructed in the form of a drop, with removable flashboards for controlling the quantity of water admitted to the canal.



Fig. 8. Finishing Wooden Pipe.

Gates are used also to control the division of water and the supply to branch canals and to individual farmers. Where used for the latter purpose, and where water is furnished by a ditch company, it is often customary to provide them with a lock which will hold them in any position, to prevent tampering

with them, and not to allow anyone to get more than his share of water.

Various forms of waste gates are used to dispose of the surplus water from a reservoir or canal, consisting of actual gates, or of a drop with removable flashboards over which the water will pass, if it exceeds a certain height, thus protecting the canal or reservoir from the danger of too much water.

Where there is liable to be a deposit of earth near the entrance to a canal, a sluice gate is often provided in order to dispose of the same by the velocity of the water through the gate. The

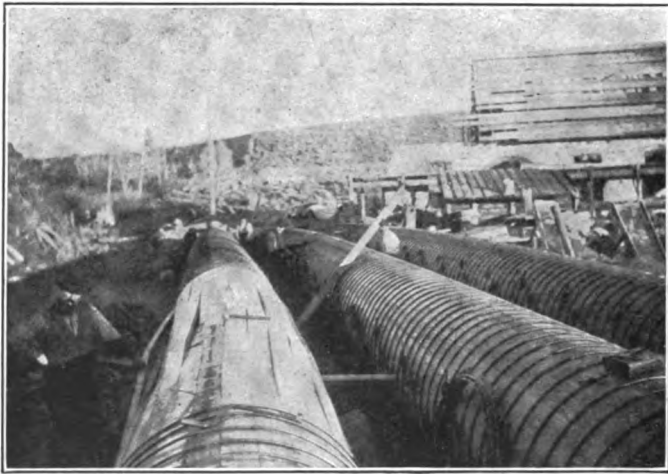

Fig. 9. Joining Two Sections of Wooden Piping.

sluiceway is usually perpendicular to the entrance to the canal, and the gate is arranged to open from the bottom, thus making a strong current to carry away the deposits.

Where water carries a large amount of sediment, sand traps are often provided, and are commonly constructed by enlarging the section of the canal greatly, so to cause a slow velocity and give the water an opportunity to deposit the sediment instead of filling the ditches with it. The sediment is then disposed of by means of a sluice gate. In some streams with an alluvial bottom it is customary when the stream is low, instead of allowing the water to enter canals into which it is to be diverted

normally by means of a weir, to run a temporary wing dam up stream to prevent the large seepage losses from the water covering a large area of the bottom of the river.

In some places dams are constructed of brush and rock, which, while far from water tight, will yet force the water sufficiently high to enter the canals. These structures serve their purpose as long as there is sufficient water in the stream.

At the junction of two or more canals, a division box is usually constructed, for dividing the flow into the various canals. Such structures are commonly made of wood, and the adjustment

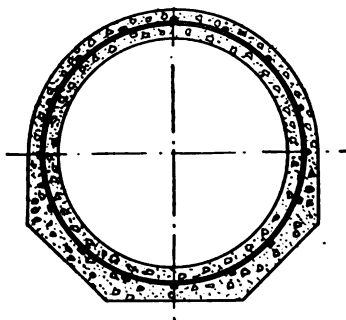

Fig. 10. Cross-section of Reinforced Concrete Pipe.

of water flow is accomplished by means of gates. From the main canals the water is led into lateral canals, from which it is distributed to the land by the irrigators.

Small ditches or canals are usually constructed by plowing the land first and then cleaning the dirt out by a V or other type of scraper, or by other means, the shape usually depending on the type of construction and instruments used. Larger ditches are usually built by the use of drag scrapers.

Calculation of the Flow of Water in Ditches.

The following formula gives V the velocity in feet per second of water in ditches.

$$V = C \sqrt{rS},$$

where r is what is known as the mean hydraulic radius, *i.e.*, the quotient obtained by dividing the cross-sectional area of the water in the ditch, in square feet, by the length in feet of

the wetted perimeter of the bottom and sides of the ditch; and S is the slope of the ditch. For example, if the cross-section of the water in the ditch be given as in Fig. 11, then

Area = $12 \times 3 = 36$ sq. ft.
 Wetted Perimeter = 18 ft.,
 and $r = \frac{36}{18} = 2$.

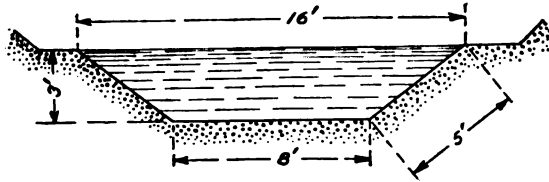

Fig. 11. Cross-section of Ditch.

If the grade of the ditch be 1 foot per 1000 feet, then

$$S = \frac{1}{1000} \text{ and } V = C \sqrt{\frac{A}{P}}$$

According to what is known as the Chezy formula, the value of C is given for various materials and slopes, but according to the formula of Kutter, which is generally accepted by engineers,

$$C = \frac{41.66 + \frac{1}{n} + \frac{.00281}{S}}{1 + \left(41.66 + \frac{.00281}{S}\right) \frac{n}{\sqrt{r}}}$$

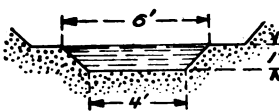

Fig. 12. Cross-section of Ditch.

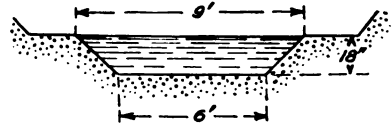

Fig. 13. Cross-section of Ditch.

where the following values of n are given for various materials:

n .	KIND OF SURFACE.
.010	Plain board or smooth cement.
.012	Common board.
.013	Ashlar or good brick.
.017	Rubble.
.025	Earth.
.030	Earth with aquatic plants.

As an approximation sufficiently close for most practical purposes, this may be written

$$C = \frac{42 + \frac{1}{n}}{1 + \frac{42n}{\sqrt{r}}}$$

The following figures give velocities and rates of discharge for the farm ditches given in Figs. 12 and 13, corresponding to values of n of .025.

FLOW IN DITCH SHOWN IN FIG. 12.

Feet per 100 feet slope	Feet per mile slope	Velocity feet per second	Discharge rate cubic feet per second
0.0317	1.67	0.556	2.8
0.1264	6.67	1.118	5.6
0.253	13.33	1.585	7.9
0.379	20.0	1.940	9.7

FLOW IN DITCH SHOWN IN FIG. 13.

0.0317	1.67	0.764	18.6
0.095	5.00	1.324	14.9
0.1575	8.33	1.704	19.2
0.221	11.67	2.020	22.8

Measurement of Flow of Water.

The usual method of measuring the flow of water for irrigation is by means of a weir, which consists of a structure with a horizontal edge over which water pours. When a weir is used for measurement purposes, the plane with the horizontal edge is vertical and the edge on the inside is sharp and beveled, so that the water touches it only in a line. Three forms of weirs are commonly used, known as:

1. Unsuppressed weir.
2. Suppressed weir.
3. Cippoletti weir.

In the first two the lateral edges of the weir are vertical, while in the last case they are inclined to the vertical at an angle whose tangent is 0.25.

The unsuppressed weir consists of a rectangular opening not so wide as the channel of approach, while the suppressed weir



Fig. 14. Suppressed Weir.

has an opening the full width of the channel (see Figs. 14, 15, and 16).

In the measurement of water by weirs, the width of weir and the height of water over the crest (called the head) must be



Fig. 15. Unsuppressed Weir.

known. Shortly before the water reaches the crest of the weir it begins to curve downwards, and the measurement should be taken at a point back of the crest where the water is level.



Fig. 16. Cippoletti Weir.

The discharge rate of a weir in cubic feet per second is given by the formula

$$Q = CLH^{\frac{3}{2}}$$

for suppressed weirs and Cippoletti weirs, and

$$Q = CH^{\frac{3}{2}} (L - 0.2 H)$$

for unsuppressed weirs.

In the latter the width of discharge water is restricted by the tendency to crowd from the sides. This restriction, which is dependent on the head over the weir, is equivalent to shortening the length of weir. The divergence of the sides of the Cippoletti weir is just sufficient to overcome the effect of crowding. In the above formulæ,

$$\begin{aligned} L &= \text{Length of weir in feet,} \\ H &= \text{Head over crest in feet, and} \\ C &= \text{A constant.} \end{aligned}$$

With the Cippoletti weir, L = length of bottom of weir in feet. The value of C is usually taken as 3.33.

The bottom of the approach to the weir should be at a distance below the crest equal to at least twice the head on the weir, and the approach of water thereto should be even and uniform to insure accurate measurements.

If this is not the case, the formulæ must be corrected for the velocity of approach. (See Merriman's "Hydraulics.")

The tail water below the weir should be sufficiently below the crest of the weir not to interfere with the discharge. The following table gives discharges from suppressed or from Cippoletti weirs for various heads per foot width of weir.

TABLE XIX.
WEIR TABLE.

Ft. head	Cu. ft. per sec.	Ft. head	Cu. ft. per sec.
0.10	0.105	0.5	1.177
0.15	0.193	0.6	1.548
0.20	0.298	0.7	1.950
0.25	0.416	0.8	2.383
0.30	0.547	0.9	2.843
0.35	0.690	1.0	3.330
0.4	0.842		

In order to be able to use a weir measurement, we must be able to allow the necessary drop. Where this is not possible, rating flumes are sometimes used for measuring the flow of water. A rating flume is constructed with a uniform section (often rectangular) of wood or concrete, located in a ditch, the area

being such that the water will have sufficient velocity not to deposit sediment. A vertical gauge tells the height of water, and the flume is calibrated by measuring the relation between the flow and the height of the gauge. To be at all accurate, frequent calibration is required to provide for changes in the character of the ditch due to erosion or sedimentation, etc. To give insured reliable results there should be no causes affecting the water level for a considerable distance below the flume. Hence such a flume would be unreliable in case much of the water were liable to be diverted from the ditch, at all near the flume and below it.

The miner's inch is a unit commonly used, and the flow of water is sometimes measured by means of an adjustable slot which may be one inch wide and of variable length. The length is altered until the discharge is just sufficient to hold the water 4 inches above the center of the slot, when the miner's inches discharged are equal to the open length of the slot.

The velocity of water is measured by surface floats, by long tube floats reaching nearly to the bottom of the channel, and by current meters. For a complete description of the various means of measuring water in open conduits, the reader is referred to Merriman's "Hydraulics."

Natural Reservoirs.

The usual method of building a natural reservoir consists in the construction of a dam or embankment across a stream or water course. If the dam is liable to be overtopped by flood water, it is usually built of concrete or masonry in order to stand up under the action of the water. If, on the other hand, there is no such danger, cheaper methods of construction may be used. The first requisite for a dam is a good foundation, under which it is impossible for the water to leak. Where it is possible to do so, the foundation of the dam should be carried down to an impervious stratum, with which a tight joint should be made. The material of the dam, or at least part of the same, should be impervious to water. The dam structure should be carried up to a safe height and an ample spillway provided so that the water will not flow over the dam unless the structure be made of sufficient durability to stand the consequent wear.

The following are the types of dams commonly used:

1. Masonry dam.
2. Concrete dam.
3. Rock fill dam.
 - (a) Timber.
 - (b) Steel.
4. Timber crib dam.
5. Wooden dam.
6. Earth dam.

In each case the spillway should be made so as to resist the action of the discharge water, and in all except the first two cases it must be built of a size and at a sufficient distance below the crest of the dam, to take care of the worst conditions of flood. In figuring the amount of water to be discharged by the spillway, unless more definite data are at hand, the same may be estimated from the drainage area, the rate of rainfall, and the percentage run-off of the land, during severe storms. The maximum discharge may also be calculated by noting the highest level of the flood-water and figuring the flow from the cross-section and slope of the ground.

To avoid the action of the erosion of water, the spillways are usually so made as either to let the water down gradually or in steps, or else the construction is such that the falling water strikes a water cushion formed by the back water in the stream below the dam.

With concrete and masonry dams, usually a small overflow will do no damage; but if a large quantity of water may flow over the crest, it is often rounded on top and the dam is so curved on the bottom as to change the direction of the falling water towards the horizontal.

Masonry and Concrete Dams. — It is particularly important for masonry or concrete dams to have a good foundation, preferably on bed rock. In case this is not obtainable, rows of sheet piling with suitable flooring are sometimes used. Frequently 4-inch \times 12-inch timbers are used for this purpose. One edge is cut to a groove, and the other edge dressed to enter it. The timbers are beveled on the end so as to hug together when driven, and the rows of piling are run across the bed of the stream, and flooring nailed to stringers is then laid along stream.

Where the foundation is of rock, a trench is usually cut in the same, to form a water-tight joint with the dam. For masonry or concrete dams this is usually filled with concrete above the rock level and the dam built around it. In the calculation of dams of this nature, there are three ways of possible failure which must be figured.

1. Crushing of the material of the dam.
2. Failure of the dam by tension in the masonry.
3. Sliding of the dam on its base.

In figuring the stresses acting, the combination of weight and effect of water pressure, and also the wind pressure when the reservoir is empty, must be figured. In a properly designed masonry or concrete dam there is no danger of the dam overturning, since, if the dam be figured so that there is no tension in the masonry, the line of resistance must be kept within the middle third of the section.

In the construction of the masonry no horizontal courses should be used, as they would provide a natural plane of cleavage for the dam from the lateral water pressure. In addition to the stresses mentioned, in cold climates the lateral pressure of ice must be considered, as well as the brush and logs which may be carried over the dam by a flood.

For an extended discussion of dams, the reader is referred to Schuyler's "Reservoirs for Irrigation Water Power and Domestic Supply," and to Wegmann's "Design and Construction of Dams."

Reinforced concrete is used in dam construction, and has many structural advantages in the more economical use of material, modification in design, and increased economy. The steel in the concrete not only allows tension stresses not permissible with masonry, but also allows far higher compressive stresses to be used, due to the steel, insuring a more equal distribution of compressive stress than would otherwise exist.

Some masonry dams are built curved in plan, with the water pressure acting on the convex side. If the abutments are solid rock, the curved form acts like an arch, and adds materially to the strength of the dam; also should any cracks tend to develop on the inside, the tendency of the water pressure is to close them up and prevent leaks. The curved dam is longer than the straight dam, but the additional strength allows a lighter construction to be used with safety.

Concrete cores are sometimes used in the center of earth dams, and not only tend to make them water tight, but add to the safety of the dam, particularly in event of the possibility of floods overtopping the dam. The cores are usually only a few feet thick; and while the construction would not allow a large overpour, still the resistance to damage or destruction from the same would be much greater than where no such precaution is used.

Rock-Fill Dams. — A rock-fill dam consists of an irregular mass of rock with some kind of an impervious core or covering. For the latter purpose timber and also steel have been used. The timber is laid on the inside, usually in a double layer so as to break joints, and the joints are thoroughly coated with asphalt, to make them tight. Where steel is used, about 0.25-inch plate is usually employed, and after being riveted and caulked is bedded in concrete in the center of the dam, the concrete forming a mechanical protection and also preventing rust. The steel or timber is carefully bedded at the bottom of the dam to form a tight joint. The slope of the rock used varies from one-half horizontal to one vertical up to one and one-half horizontal to one vertical. Rock-filled dams will not allow any quantity of water to pass over them with safety.

Timber Crib Dams. — This is a common form of construction where lumber is plentiful, and consists of a cribwork of logs which is usually fastened at the intersections with drift bolts, and which is filled with rock. Often the back of the dam is simply filled with dirt and clay to make it water tight. In dams of this nature the spillway is frequently built of logs, in a series of steps.

Wooden Dams. — There are quite a variety of forms of wooden dams in use. Where they are built on unstable ground, the foundation is usually constructed of sheet piling covered with a flooring. A form of dam or weir used extensively in certain localities consists of from two to three rows of sheet piling with flooring, on which is built an inclined sheet dam of timber, braced to the flooring on the down-stream end. Where used as a weir, removable flashboards are provided and a walk is built on a superstructure over the weir. The superstructure is purposely made weak, so that in case of brush catching thereon and backing up the river so as to endanger the weir, the super-

structure will give way. The overflow water runs over the flashboards and falls on the flooring, protected by whatever water cushion the back water may afford.

Earth Dams. — In building an earth dam, the surface soil and all vegetable matter are first removed, then the ground is plowed to make a tight joint with the material which goes on top. It is customary to dig down to an impervious stratum and build at least part of the bank of impervious material, thoroughly compacting it, as it is built, but taking care to form no plane of cleavage through which the water might subsequently seep.

In many places earth dams have been constructed by hydraulicking the dirt into place, leading it to the dam by troughs and pipes at a very low cost. Where water under pressure was not available, pumps have sometimes been used for this work. Some form of protection must usually be provided against wave action on the inside. Rough stone laid in place, known as riprap, is commonly used, and timber is also employed for this purpose.

Embankments. — Earth tanks and artificial reservoirs are usually constructed entirely in embankment.

Many artificial reservoirs, built of earth, are at present in use in irrigation, some of which are supplied by windmills, while others derive their supply from pumped water or artesian wells. The reservoirs generally are of small size, though a few of considerable capacity have been built for artesian wells. As a rule they are quite successful, although in some instances where the soil is unfavorable and the construction poor, difficulty has been experienced in making them hold water.

A common method of construction which is frequently adopted for reservoir banks, is to plow down to clay under the bank of the reservoir, to make a water-tight joint, and to tamp the bank thoroughly during construction by letting the teams make the circle of the reservoir bank after dumping their load. Sometimes a layer of clay is put on the inside bank of the reservoir, and in other cases dirt alone is used in the formation of the banks. If clay is used, it would be far preferable to have it in the center of the bank, where it will be protected from drying out or freezing. Some reservoir banks constructed of black, waxy soil, answer all requirements for holding water.

Leaky reservoirs have frequently been remedied by puddling and tamping, by driving stock around on the inside. Goats or sheep answer particularly well for this purpose, as their hoofs are so small that they compact the earth thoroughly.

The bottom of a certain large reservoir, for an artesian well, with a clay stratum below the ground, appeared to be porous, and water went through it like a sieve. After puddling and tamping the bottom by the use of stock, however, no difficulty was experienced in making it water tight.

The first requisite for an earth reservoir, if unlined, is an impervious stratum within easy reach of the ground. If this stratum consists of clay, or clay and sand, the usual method of construction is to dig a trench down to the stratum and fill it with water-tight material put in in layers, rammed or rolled in place. The bank as it is built up is compacted in some manner, either by tamping or by rollers, and the interior at least, of the embankment, is made of water-tight material.

Puddle, which consists of a mixture of clay, sand, and gravel, is often used for this purpose. Sometimes equal proportions of the three materials are used. They are carefully mixed and moistened and compacted. Puddle is usually used in the trench below the ground, and also in the core of the reservoir bank. The following puddle mixture, laid in 2-inch layers, harrowed and rolled, is sometimes employed:*

Coarse gravel	0.74 cubic yard
Fine gravel	0.26 " "
Sand	0.11 " "
Clay	0.15 " "
	<hr/>
	1.26 " "

making one cubic yard of puddle.

Embankments are usually constructed of material which is close at hand, as the distance which the dirt must be handled is a very important item in the cost of construction. Where it has been impossible to obtain clay, loam has successfully been used as a substitute in puddle.

With regard to the cost of earthwork, the following figures are taken from H. P. Gillette's "Earthwork and Its Cost," and are based on 15 cents per hour for labor, and 10 cents per hour per

* Fanning.

horse. They do not include charges for foreman, timekeeper, blacksmith, watchman, water-boy, interest, and rental of plant, nor cost of grubbing, draining, spreading, rolling, sprinkling and insurance.

TABLE XX.
COST OF EARTHWORK.

	Cost per cubic yard material, cents				Additional for each 100 feet
	50	100	200	1000	
Length of haul—feet.					
Wagons on soft earth roads	18.7	18.7	19.4	25.0	0.7
Wagons on hard roads	18.4	18.4	18.8	22.0	0.4
Drag scrapers	9.0	10.0	14.0	46.0	4.0
Wheel scrapers No. 1	7.5	8.75	11.5	33.5	2.75
Wheel scrapers No. 2	9.2	9.2	11.4	29.0	2.2
Wheel scrapers No. 3, with snatch team	9.5	9.5	10.7	20.3	1.2
Elevating grader on soft earth roads Cars loaded by hand and hauled by team	10.5	10.5	10.5	13.0	0.5
	17.0	17.0	17.0	17.0	0.1

These costs are for average earth, readily plowed. The cost of rolling with a 2-ton grooved roller will be one-half cent per cubic yard, and on large work, by the use of a Shuart grader, the cost of spreading will be the same. With proper appliances, sprinkling can be done for 0.4 cent per cubic yard, if water is near at hand. Harrowing will cost 0.35 cent per cubic yard.

Earth has been handled hydraulically in making fills, at a cost of 4 to 16 cents per cubic yard. The water pressure for hydraulicking earth is usually obtained by gravity, but occasionally it has been obtained by pumping.

The cost of reservoir embankments will usually lie between 10 cents and 30 cents per cubic yard. In Southern Texas wages are low, the average pay of Mexican labor per day being between 50 cents and 38 cents, without board. This labor, it is true, is not as efficient as American labor further north, but nevertheless it is far cheaper considering the work done. Unless conditions are unfavorable, a cost of 10 cents per cubic yard will usually insure the contractor a good profit for the construction of embankments with short hauls. In the North 20 to 25 cents per cubic yard might be a fair price to expect for such work.

The banks of reservoirs of any extent must be protected from the waves in some manner. Riprap, consisting of stone roughly laid in place, is commonly used for such purposes, the thickness of the layer usually being 10 to 12 inches. Assuming that riprap weighs 100 pounds per cubic foot to allow for the voids, the weight of one cubic yard will be 2700 pounds, and the weight of one square yard 10 inches thick, 750 pounds. At 35 cents per hour for team and driver, it will cost to haul the riprap, from 5 to 10 cents per mile, per square yard, depending on the roads. Assuming 7 cents, it will cost 21 cents for a three-mile haul. To this must be added the cost of loading and unloading, and distributing the stone, say, 9 cents per square yard, or 30 cents total, provided the stone is readily obtainable without blasting. Much of the Mississippi levee work has been riprapped 10 inches thick, at a cost of 27 cents per square yard, the stone being conveyed about 40 miles by barges.

The proper slope for earth banks varies with the material of the banks, and the protection of the same from waves. In general the inside slopes of earth reservoirs are from 3 to 1, to 2 to 1, and the outside slopes from 2 to 1, to $1\frac{1}{2}$ to 1.

Table XXI, taken from Molesworth, gives the angles of repose of various earths.

TABLE XXI.
ANGLES OF REPOSE.

	Degrees	Horizontal	Vertical
Compact earth	50	.75	1
Clay, well drained	45	1.00	1
Gravel	40	1.25	1
Dry sand	38	1.25	1
Wet sand	22	2.50	1
Vegetable earth (loam)	28	1.75	1
Wet clay	16	3.00	1

Gravel shores exposed to wave action will finally take a slope of 5 to 1, to 10 to 1. If the bank is protected by riprap, it may be given a steeper slope than if unprotected. Riprap does not need to be carried to the base of a reservoir bank, as the action of the waves from shallow water has comparatively little effect,

and as further little damage will be done should slight caving ensue near the base of a bank, provided there is plenty of material above to fall in place.

When embankments are constructed from 40 to 50 feet in depth, it is customary to use a berm on the inside. The berm is a horizontal offset in the slope of the bank, and is particularly designed to allow for settlement or caving of the embankment.

Reservoir Linings.—Where reservoirs will not retain water, due to seepage, it is necessary to line the bottom and sides with impervious material. Puddle is sometimes used for this purpose. The gravel is first spread in a 3-inch layer over the surface, and then clay over the gravel, and sand over the clay, in proper proportions. According to Gillette, the cost of such puddle lining is as follows:

Spreading by hand	8 cents per cubic yard
Harrowing	5 " " " "
Sprinkling	2 " " " "
Rolling	5 " " " "
	20 " " " "

To this must be added the cost of hauling the various materials. If this cost be 40 cents, corresponding to a mean haul of 1 mile by wagons on good roads, puddle would cost 60 cents per cubic yard, or 10 cents per square yard, 6 inches thick.

Concrete is sometimes used for reservoir lining. The cost varies widely, depending on the length of hauls and on the strength of the mixture. The materials for concrete will usually cost from \$3 to \$8 per cubic yard. The cost of mixing and spreading will depend largely on the size of the undertaking. A large reservoir near New York was lined at a cost of 60 cents per cubic yard for mixing, distribution and spreading, 6 inches thick. If the concrete cost \$5.40 for materials, it would then cost \$1.00 per square yard, 6 inches thick.

Small earth tanks have been lined with the following mixture: 73 per cent of sand is mixed with 2 per cent of air-slacked lime, and then poured into 25 per cent of coal tar. The mixture is applied 53 pounds per square yard of surface, or about 0.5 inch thick. The surface is then coated with tar paint, which has first been heated and flashed until the grease is burned out.

MATERIAL PER SQUARE YARD.

Lime	0.7 pound.
Sand	38.3 pounds equal 0.011 cubic yard.
Tar	14.0 pounds.

This would be too thin a coating to apply to a reservoir of any capacity, however, without a good foundation of rock or stone.

Wells.

The usual means of tapping the underground water-supply is by sinking a well. In the following chapter the nature of wells is treated at length. In case the sides of the well are sufficiently firm not to cave, the well need not be curbed or cased, but if, as is usually the case, the material of the sides will not stand up, it is necessary to provide suitable supporting material. The majority of irrigation wells are bored wells and are either open-bottom wells or have their casing provided with a strainer. If the stratum above the water-bearing stratum is of such a nature that it will be sufficiently self-supporting, the open-bottom well is preferable, since it causes less restriction to flow into the

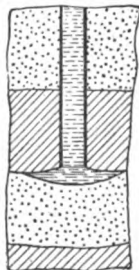

Fig. 17. Proper Casing.

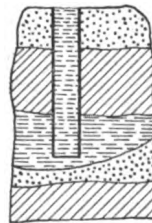

Fig. 18. Casing too Deep.

casing. In some places, however, the nature of the material of this stratum is such that it will ultimately cave, and, in this event, it is necessary to insert a strainer in the well. If an open-bottom well be used, great care should be taken to stop the casing just at the top of the water stratum, and not to let it project into it, with the inevitable result that it will throw out large quantities of sand, greatly increasing the possibilities of caving. This is evident by reference to Figs. 17 and 18, the former representing the casing properly put down and the latter

showing the effect of a casing too far down. Where a strainer must be employed, it should fulfill the following qualifications:

1. It should be sufficiently strong and of such material as not to be injured when being put down the well or by chemical action of the well water.

2. The openings should be sufficiently large to admit water and keep out sand, or at least to prevent the coarser sand which will collect around the strainer from passing through.

3. The openings should increase in size toward the inside, to ensure that particles of dirt which start through the openings will be carried through and will not plug up the holes.

4. The resistance to flow of water should be as small as possible. The strainer should hence be as large in diameter, and as long as possible. The resistance to the flow of well water limits the output of the well. This resistance is composed of friction in the pipe, in the entrance to the casing, and in the ground leading to the casing. Pipe friction is dependent on the size and depth of well. Friction at entrance depends on the strainer, its length and diameter, as well as the nature of the ground immediately surrounding the same. Friction in the ground depends on the quality and thickness of the water stratum. The coarser the sand and gravel, the less is the resistance to flow, and the better the indications for a good well, other things remaining the same. The existence of a spring is evidence of the fact that water in the ground is under pressure, and is a good indication of the probability of obtaining an artesian well, if the elevation of the well is not far above that of the spring. Although in the majority of cases the probable results of a well may be inferred from wells near by, still it should always be borne in mind that it is practically impossible to be certain of the result of sinking a well, owing to the formation of the ground and faults therein, and that it is not infrequently the experience that of two wells of the same size and depth but a very short distance apart, one will have an abundance of water while the other may have practically no supply.

In a certain case where water was in limestone formation and many excellent flowing wells were bored, striking a subterranean channel, one well in the same district had a very weak artesian flow, though it was much deeper than surrounding wells. The water-bearing formation was of a close-grain rock which strongly

throttled the supply, and the owner was convinced that the only reason his well gave so little water was simply because he was a poor man.

Among the strainers employed may be mentioned the following:

1. The well casing is perforated from within by a punch which cuts a slot bulging outwards about $\frac{1}{4}$ inch wide and 1 inch long. This forms an excellent strainer for some soils. The perforations, which are numerous, are usually made before the screen is put down. (See Fig. 19.) Sometimes the perforations are made by a perforator or cutter working within the casing after it is in place, but this is less liable to give good results, and the holes are liable to be too large.



Fig. 19. Casing Perforations.

2. The well casing is drilled with numerous small holes, and the outside of the casing is wound with copper wire leaving slight spaces between the convolutions. The wires are then soldered longitudinally to hold them in place.

3. A similar strainer is used, covered on the outside by copper or brass gauze.

4. A strainer similar to (2) is used, except that the wire is of a trapezoidal shape, with the shorter leg inside next to the pipe and the longer leg outside, so that there is a taper passage, and particles starting to enter the casing will probably continue through.

5. The Cook strainer consists of a brass pipe perforated from the inside by fine circumferential slots. In case this strainer encounters resistance in putting it down, it is liable to close some of the slots.

6. Some so-called strainers are used, in which the pipe is simply bored with holes about $\frac{3}{8}$ inch in diameter. This in reality is not a strainer, and has about the same effect as an open-bottom well, except that the water is more throttled by entrance to the small holes, and should caving of the upper strata occur the well is not so likely to be entirely stopped up.

In well boring it is quite common, especially in deep wells, to encounter several water-bearing strata, and frequently the quality of the water obtained therefrom is such as to be absolutely unfit for irrigation, due to impregnation with the salts in the ground. Such strata must be cut off and

prevented from mingling with good water, in case the same be found.

In some wells the water pressure is sufficient to raise the water above the ground level and cause artesian flow, but in the great majority of cases the water stands below the ground and must be elevated before it can be used. Drawing on the well will cause the water to sink further in the well, necessitating an additional lift. The effect of the discharge on the level of water in the well has an important effect on the cost of raising water and will be discussed more fully in the next chapter.

If the discharge of the well deriving its water from sand strata be too great, it will tend to carry the sand into the well, resulting in sanding up of the well. In one case a certain artesian well was cleaned out in the following manner: A small pipe was run 100 feet down the well, and was connected at the top to a receiver in which a high air pressure had been pumped up. When the air valve was opened the discharge shot the water out of the well like a geyser. When the water subsided, the level fell and remained several feet down the well. A sounding showed that the bottom of the well had filled up with about 40 feet of sand, shutting off the flow. The air compressor was then started pumping gradually from the well, and in a few minutes run had removed not only the sand blown into the well but additional sand which was in the bottom, and restored the full artesian flow.

Where the water stands below the level of the land to be irrigated, it must first be elevated before it can be used for irrigation. For this purpose some form of pumping machinery must be used. The use of machinery for the elevation of water dates back to the earliest records of history, some of the first forms consisting of a bucket on a long lever, the center of which was pivoted on a cross bar. This device was operated by hand by a man on the other end of the lever. Even to-day, places can be found where, when a dry spell comes on, the farmers will make frantic efforts to save their crops by hauling water in barrels and distributing it by hand. Of course, such crude irrigation is very expensive, and usually quite inefficient, due to the small supply of water used.

In addition to the pump, some form of motor or engine must usually be used to drive the pump. The motive power may be

either steam, hydraulic, electric, pneumatic, or else gas or gasoline, and sometimes draft animals are used.

While gravity systems are usually preferable, still, in many cases, where the development cost is high, the cost of water so obtained will exceed the cost of pumped water, especially where the lift is low. In obtaining water by pumping, four things must be considered:

1. The vertical height which the water must be raised to elevate it sufficiently to reach the highest point on the land.

2. Variations due to the season, or other causes, in the water level.

3. The amount the water level will be affected by pumping, and

4. Whether the available supply is sufficient at all times to furnish the pump with the required supply.

It is impossible to raise water by suction, a distance greater than 34 feet at sea level and less distance at higher altitudes. In practice, from 28 to 30 feet will be about the limit at sea level. Consequently the pump must be located a distance less than 30 feet above the lowest level to which the surface of the water supply for the pump will fall. Also, generally, it is desirable for most forms of pumps not to be submerged when the water is at its highest level.

Usually the ground water and also the standing water level in wells is subject to annual variations of several feet, depending on the seasons and on the water supply for the strata on which the well draws. It is customary in many places in pumping from wells to dig pits in which to set the pumps in order to locate them sufficiently near the water level to be within the suction limit. It is generally preferable, if possible, to locate the pump so that it will not have to operate under too high a vacuum, since suction piping is more difficult to keep tight than pressure piping, and since, moreover, a very small leak of air, or the air necessarily entrained in the water (particularly in well water), will expand greatly when it enters the pump under a high vacuum, and hence will cut down the efficiency of the pump, and may make it lose its priming.

It is important to provide good foundations and suitable housing for pumps and pumping machinery, to ensure long life. The depreciation of much of the machinery used in irri-

gation pumping is usually very great, due to neglect and improper covering. To install a plant to operate economically requires a careful consideration of the type of pump motor or engine and fuel best suited to the conditions of the case, as will be explained more fully in the chapter on pumping.

CHAPTER VIII.

WELLS.

Law of Flow of Wells.

IN the consideration of the installation of a well pumping plant, it is essential to have some idea of the amount of water available, and of the depth from which it must be pumped. It is a question for the engineer to determine whether he will pump from two or more wells either a greater supply, from the same depth, or else the same supply with a diminished lift, thus either having a station of greater capacity or else one of the same capacity, but with smaller engines and decreased fuel expense. For example, suppose the ground water stands 12 feet from the ground, would it pay better to put in one well delivering 2 cu. ft. per sec. of water and lowering the water 20 ft. in the wells or else to follow one or other of the two following plans? Put in two wells delivering 3.5 cu. ft. per sec. and lowering the water 20 ft. in wells, or else put in two wells delivering 2 cu. ft. per sec. lowering the water 12 ft. in the wells. In the first and second cases the lift would be 32 ft., and in the last case 24 ft. Hence, if 2 cu. ft. per sec. were all the water desired, only two-thirds of the boiler and engine capacity would be necessary in the third case, together with a greatly diminished fuel expense, too, over what the first case would demand.

The wells will usually interfere somewhat with the flow from each other when near at hand. In order to form an intelligent estimate on this subject, a knowledge of the flow of water into wells is important. Water will rise to a certain level in a well when not flowing, due to the hydrostatic pressure in the ground. If this level be above the ground, then, if the well casing be cut off at the ground, an artesian flow will result. Should the water stand below the ground and the well be lowered further by pumping, the well will similarly

flow.* An artesian well is not different from a pumped well, except that in the former the static water level is above the point of discharge, the law of flow in either case being identical. In a given well the flow is dependent solely on the distance the hydrostatic head is lowered by artificial or natural means, and it is this lowering of head which is effective in causing flow. The relation between the flow and the lowering of the head of the well from the level of standing water in the same is known as the law of flow of the well. This head, which is effective in causing flow, is used up in friction in the ground, in entrance to the casing, and in friction in the casing of the well. However, the laws governing the flow of water into wells are not always clearly exemplified, and the results of tests to determine the same are liable to be somewhat confusing, owing to a variety of causes. The general law governing the flow of a fluid through a porous or finely divided medium, such as sand, is that the flow is directly proportional to the pressure causing the flow. In other words, if Q = cu. ft. per sec. be delivered from a unit cross-section and H = head necessary to force Q through a unit length, then $H = KQ$, where K is a constant.

The flow of fluid in a pipe is subject to the law that the quantity, Q , delivered per unit time from a fixed length of a given size pipe, varies as the square root of the head, h , causing said flow. In other words, $h = kQ^2$ where k is a constant.

Hence if Q be the flow of a well, the distance the water level must be lowered in the well to produce this flow is $H_1 = H + h = KQ + kQ^2$, H being the head necessary to force water through the ground and into the well, and h the head used up in overcoming the friction in the pipe in the well. Where the main loss consists in flow through sand or porous media the equation is practically of the first degree.

Among the causes which may obscure the action of these two laws may be mentioned the following:

1. Change in the nature of the porous medium.

- (a). It is not uncommon for wells to be developed by pumping or flowing. This is largely caused by a rearrange-

* An artesian well is often defined as a well wherein the water from a given stratum will rise above the top of the stratum. In the usual acceptance of the term, however, the water must be under sufficient pressure to deliver a flow at the ground level.

ment of the strata through which the water passes, making a decreased resistance to flow.

(b). Sanding up of the well. Wells are liable to be filled with sand to such an extent that the standing water level will be lowered many feet.

(c). Plugging up of strainers, or of perforations in the casing.

2. Leakage of water.

If two water strata of different static levels are united in a well, there will be a flow of water from the stratum of higher to that of lower pressure.

If, however, the water is lowered by any cause below the lower static pressure, outflow will be obtained from each stratum.

Leakage of water also occurs where the well casing is improperly put down, and the water follows up the outside of

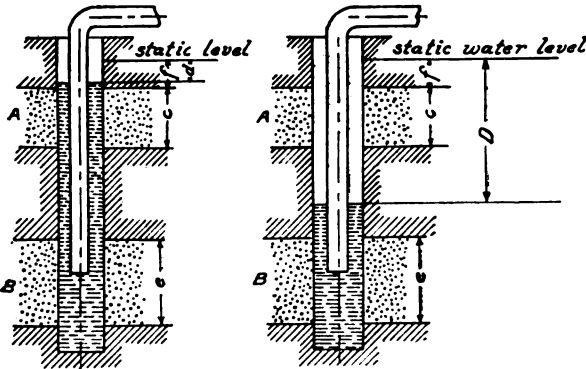

Fig. 20. Water at A and B. Fig. 21. Water between A and B.

the casing into other strata. This is liable to be a cause of serious loss in artesian wells. Holes in the casing may also cause leakage between different water strata.

3. The effect of neighboring wells, which affect the ground water level.

4. The time element.

In making tests of variation of flow and head, sufficient time must be allowed for the quantities to settle down to fairly constant values.

5. The effect of wet and dry years, which may affect largely the static water pressures.

6. When water is lowered beyond the level of a stratum, in such a way that no vacuum is produced on said stratum, the flow from it will, of course, be constant.

This will somewhat complicate the relation between H and Q ,

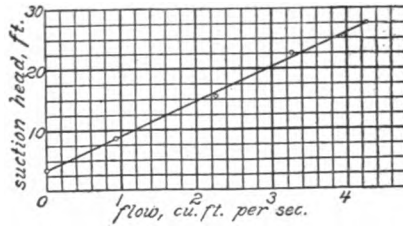

Fig. 22. Case 1.

and will introduce a constant into the equation. Take, for example, the case of a well having two water strata, A and B , each of which has the same static level. Lower the well, d , Fig. 20. So long as d is less than f , then, calling Q_a the flow from A , and Q_b the flow from B , $Q_a = d K_a$, $Q_b = d K_b$.

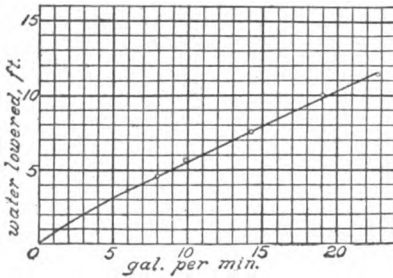

Fig. 23. Case 2.

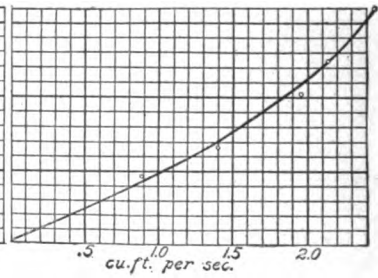

Fig. 24. Case 3.

Hence, $d = \frac{Q_a}{K_a} = \frac{Q_b}{K_b}$ and $Q = d (K_a + K_b) = d K$,

K_a and K_b being the constants for the strata, A and B , respectively.

When the water level lies between A and B (Fig. 21)

$$\begin{aligned} Q_a &= (c + f) K_a \\ Q_b &= d K_b \\ Q &= (c + f) K_a + d K_b = K_1 + d K_b. \end{aligned}$$

Practically, we would not get quite this quantity of water, since the upper part of stratum *A* would not be lowered *f* feet, immediately next to the well. The actual value would be indeterminate, however, depending on location of the main resistance to flow in stratum *A*. In the above, there is supposed to be no vacuum in the well itself, and no appreciable friction loss in the casing.

Tables XXII, XXIII and XXIV, and curves in Figs. 22, 23 and 24 show the relation between *H* and *Q* in two pumped stations, where a test was made to determine the same, and in an artesian well.

TABLE XXII.—WELL TESTS.

Case 1.

Well 1.		Well 2.		Well 3.		Well 4.		Average.	
<i>Q</i> † Cu. ft. per sec.	<i>H</i> * Feet.	<i>Q</i> . Cu. ft. per sec.	<i>H</i> . Feet.	<i>Q</i> . Cu. ft. per sec.	<i>H</i> . Feet.	<i>Q</i> . Cu. ft. per sec.	<i>H</i> . Feet.	<i>Q</i> . Cu. ft. per sec.	<i>H</i> . Feet.
4.21	27.6	4.21	27.5	4.21	27.2	4.21	27.4	4.21	27.4
3.98	25.2	3.98	25.3	3.98	25.3	3.87	25.2	3.96	25.2
3.20	22.3	3.20	22.2	3.31	23.0	3.20	21.7	3.23	22.3
2.29	15.4	2.29	15.4	2.20	15.3	2.20	15.3	2.25	15.3
.95	9.0	.95	9.0	.88	9.0	.88	9.0	.92	8.5
...0	3.3

* *H* = distance in feet from center of horizontal suction pipe to ground water.

† *Q* = rate of flow from all four wells.

TABLE XXIII.—WELL TESTS.

Case 2.

<i>Q</i> . Gal. per min.	<i>H</i> * Feet.
0	0
8.0	4.5
9.8	5.6
14.3	7.5
19.0	10.0
22.8	11.2

TABLE XXIV.—WELL TESTS.

Case 3.

<i>Q</i> . Cu. ft. per sec.	<i>H</i> † Feet.
0	0
.86	4.9
1.40	6.5
1.95	10.2
2.12	12.4
2.44	15.9

* *H* = distance in feet water in well is lowered.

† *H* = distance in feet well water is lowered below point of zero discharge.

In Case 3 the well water was throttled, and H obtained by calculation from pressure behind the throttle.

In Case 1 there were four 13-inch shallow wells which supplied water for the pump, and consequently there was practically no friction loss in the casing, the whole loss being confined to the sand, which was the water-bearing stratum, and to entrance to the casing through the perforations.

In the second case a deep-well pump was used on a 6-inch well which was open bottomed. The rate of water supply was so small that there was practically no friction loss in the casing.

The two curves of H and Q are practically straight lines, and may be represented by the equation, $H = KQ$, thus confirming the results obtained in theoretical and experimental formulæ for the flow of water through sand.

The figures and curves in Case 3 show the relation between H and Q in an artesian well. The water-bearing stratum was rock, and the water was found in subterranean passages and chambers in the rock. The friction loss in the well and casing constituted the main loss of head, and the curve can be approximately represented by the equation, $H = KQ^2$.

The time element entered largely into this test, and, as the time of making the same was limited, this of necessity introduced some error in the results.

The two laws of the flow of water are well exemplified by the difference between curves 1 and 2 and curve 3.

Where the friction is in the pipe, it can be figured closely, but where it is in a roughly drilled uncased hole, it can be figured only approximately.

The general law governing the output of artesian water or pump water is $H = a + bQ + cQ^2$; where Q = rate of discharge of well, a = distance of static level of the water below the level of discharge. (In an artesian well a will be negative, as the water will stand without flow above the level of the discharge.) H = vertical distance between the level to which water is lowered in the well and the point of discharge. b and c are constants. In the case of the artesian well not pumped, H would be zero, and the equation would then be $-a = bQ + cQ^2$. As a general proposition it can be said that the head causing flow in a well is used up in overcoming the frictional and other losses in the ground strata, and at entrance to the casing, and

also in friction in the casing itself. The pipe losses, and losses of head at entrance, if the well is open bottomed, may be calculated from the tables of friction losses and velocity heads for the flow of water in the pipes. As an approximation, sufficiently accurate for practical purposes, it may be assumed that losses of this kind vary as the square of the velocity, and hence as the square of the flow of the well. Hence the value of c may be calculated, and the losses in the ground and flow into the casing may be assumed to vary according to the first power of the flow, and hence will contribute solely to the coefficient, b . There is no practical means of ascertaining this coefficient, except from an actual test, which must hence be made in order to be assured of the correctness of the figures. As an approximation, however, it can be determined by calculation from the measured flow of the well and the height to which the water would rise above the outlet without flow.

In a pumped well, the pump must operate against a head, a , to start to deliver water. H will represent the head against which the pump must operate to supply the increased delivery.

To illustrate the method of calculation employed, assume that an artesian well is of the open-bottom type and is composed of 200 feet of 4-inch pipe and 500 feet of 6-inch pipe and is delivering a flow of 352 gal. per min. The losses in head are as follows:

* Loss of head at entrance to 4-inch casing = $\frac{1}{2}$ velocity head	= 0.63 feet
* Friction in 200 feet 4-inch pipe	= 15.3 feet
Friction in 500 feet 6-inch pipe	= 5.7 feet
Loss of head where pipe changes = Head due to difference of velocities in pipes:	
Velocity in 4-inch pipe = 9 feet per second	
Velocity in 6-inch pipe = 4 feet per second	
Hence lost head = velocity head due to 5 feet per second	= 0.39 feet
Velocity head in 6-inch pipe	= 0.25 feet
Hence total loss of head due to pipe losses	= 22.3 feet

If the measured head in the pipe, to which the water would rise above the point of discharge, be 40 feet, then the loss in the ground strata would be $40 - 22.3 = 17.7$ feet, which would be the head required to force a flow of 352 gal. per min. into the well. Assuming that the resistance to flow in the ground strata and into the well varies directly as the flow, the fol-

* See page 108.

lowing values can be substituted in the equation of the flow of the well when discharging without pump:

$$\begin{aligned} H &= 0 \\ a &= -40 \\ cQ^2 &= c \times 352^2 = 22.3. \end{aligned}$$

Hence,

$$c = .00018$$

$$b = \frac{17.7}{352} = .050.$$

Hence, the equation becomes $H + 40 = .00018Q^2 + .05Q$.

If it were desired to double the flow from the well, then by substituting the necessary value for Q in this equation, the corresponding value of H would be 84 feet. In other words, in order to double the output of the well it would be necessary to lift the water by the pump against a head of 84 feet.

Suppose, now, that with the same length and conditions of casing, the static head of the well is 8 feet above the level of discharge, then $a = -8$. Suppose, also, that when the well is discharging freely, due to artesian flow, the rate of discharge is 88 gal. per min.; by similar computations it can be shown that $c = 0.00018$ and $b = 0.075$. In order to double the rate of flow of this well, it can be shown that the pump would have to operate against a head of 10.8 feet, which is a moderate lift. Hence, were the first cost of the well high, it would probably pay to supplement the natural flow of the well by the aid of a pump, since the output would be doubled at a comparatively small initial expense, requiring about a 2-horsepower motor and corresponding pump. On the other hand, in the first case considered, owing to excessive lift it would probably not pay to install a pump to assist the well. These two cases will illustrate in a general way the problem of obtaining additional water from wells by pumping. If the pressure in the well is low and is used up mainly in overcoming resistance to the flow in the ground, and not in pipe friction, then, in general, pumps can be advantageously used to increase the well flow; but, on the other hand, if the static head in the well is large and a considerable part is used up in overcoming the pipe resistance, then the additional water can be obtained only at the expense

of a considerable expenditure of energy, since the frictional losses vary as the square of the flow. This method of calculation of the flow of wells and variations in the same, while not strictly accurate, owing to causes already explained, still will answer approximately, provided more definite information cannot be obtained. It is preferable, where tests can be made, to put in a temporary pump, to see the actual performance of the well. In practice it may be considered as the safest plan for determining the flow of the well.

Another method, however, which may be adopted in artesian wells, is to throttle the discharged water and note the variation of discharge rate for various pressures at the top of the well. By plotting these the curve of well-discharge rate and head may be obtained, and hence the law of flow may be more definitely determined for points beyond the actual observations.

There is, within limits, an uncertainty in calculations based on the results of observations of the static head and discharge rate at one level only, which is that in some wells the lower portion of the well is not cased. The friction in the well hole would, in general, be greater than friction in the corresponding size of pipe, but the absolute value would be somewhat indeterminate.

The level of the water in wells may fluctuate, due to many causes, which are classified by A. C. Veatch in *Water Supply and Irrigation Paper, No. 155, United States Geological Survey*, a brief description of which is as follows:

The regular annual fluctuation is due in large part to the amount of rainfall actually reaching the ground water. In the summer a large part of the rainfall is evaporated and lost in transpiration, and does not seep into the earth, but when the weather is cooler the reverse is true. The effect of individual rains is largely obliterated, due to the time element. Irregular distribution of rainfall may affect the curve of annual fluctuation. Single showers affect the water level by transmitting their pressure to the ground water through the soil air, which cannot escape through the wet surface of the ground. Fluctuations due to this cause are abrupt, while those due to the added water from single showers are gradual.

A rise in the barometer will cause the water level to fall in the well, and vice versa for a fall in the barometer. A rise of

temperature will decrease the surface tension and will release the capillary water just above the ground water level, thus causing a rise in the well water. With a fall in temperature the reverse result takes place.

Fluctuations are produced by adjacent bodies of water, such as rivers, lakes, or the ocean, etc., either by changing the height of the ground water discharge, or by seepage flow into the ground water, or by transmitted pressure, due to plastic deformation, which may be felt even in deep wells. In certain wells on Long Island there was a fluctuation of 5 feet in level, following the tides, which fluctuated 8 feet.

The settlement of the country, involving the destruction of the forests, cultivation of fields, changing the nature of the seepage surface, the irrigation of lands, the construction of dams, the development of the underground supply and the effect of pumped or artesian wells all serve to affect the level of the ground water.

When water flows into a tubular well, the head in the ground used up in forcing the water to the well may be represented as follows: Let $2R$ be the well diameter in feet, and let $2r$ = diameter of a concentric circle. Let T = thickness in feet of water stratum, and let transmission constant of the sand be K . Let Q = flow of well - cu. ft. per min. Suppose the water level in the well is not drawn down below the top of the water-bearing stratum, then, if we consider the resistance to flow in passing through a cylinder of sand T high, of thickness dr and radius r ,

$$dh = \frac{Qdr}{2\pi rTK} = \text{ft. head lost,}$$

where H = depression in feet, of water in well due to flow, and h = depression at any point.

Hence,
$$h = \frac{Q}{2TK\pi} \log_e r + A.$$

And integrating between

$$r = R, \quad \text{and} \quad r = r$$

$$H = \frac{Q}{2TK\pi} \log_e \frac{r}{R} = \frac{Q}{2TK\pi \log_{10} e} \log_{10} \frac{r}{R}$$

Table XXV gives values of $\log_{10} \frac{r}{R}$ for various casings and diameters of surrounding cylinders. As an approximation, the loss in head in the first 10 feet is greater than the loss in the remainder of a 100-foot circle. However, these figures make no allowance for the loss of head in entering the casing, which may be large. For example, if the well is in sand, and has a strainer, then, near the casing, the water flow must be diverted from its path normal to the cylinder to the openings in the strainer. As the strainer area of open spaces is necessarily but a small percentage of the whole surface, the water must necessarily move for a small distance at a velocity many times the velocity in the ground, were it to enter the whole casing. Also, if the flow is large, even if the water stratum is of gravel, the head lost in entrance to the perforations themselves may be considerable.

TABLE XXV.

Values of $\log \frac{r}{R}$ for Various Values of $2R$ and $2r$.

2 R × 12 = well diam. in inches.	Values of 2 r. Feet.			
	10.	100.	1000.	10000.
4	1.50	2.50	3.50	4.50
6	1.30	2.30	3.30	4.30
8	1.20	2.20	3.20	4.20
10	1.08	2.08	3.08	4.08
12	1.00	2.00	3.00	4.00
14	.93	1.93	2.93	3.93

Hence increasing the diameter of the wells will, in general, result in conditions somewhat superior to what might be expected from the preceding table. If the formula last given be integrated up to $r = \infty$, then the head will also be infinite. Of course the depression of the ground water, occasioned by drawing on the well, decreases rapidly when the distance from the well increases. To attempt to find a general application of the formula, without further assumption, would be useless, as it could be considered to apply only near the well, where the stratum was of the same material. However, the general slope

of the ground-water plane will be a very important factor in determining the actual lowering of water in the well.

If we assume a value of r the radius of a circle, beyond which the influence of the well will not be felt, then the problem may be solved. As a rough approximation, it may be assumed that all water in the ground, which previously flowed past the cross section of the height of stratum, and diameter $2r$ given above, flows into the well. Then if slope of ground water be S , the flow in the ground through a body of soil of area $2Tr$ will be $Q = 2TrKS$ where K is the transmission constant. But

$$Q = \frac{2HTK\pi \log_{10} \frac{\epsilon}{r}}{\log_{10} \frac{r}{R}} = 2TrKS.$$

Hence, assuming H , r may be found from the equation

$$r \log_{10} \frac{r}{R} = \frac{H\pi}{S} \log_{10} \epsilon.$$

In the following, T = thickness of water-bearing stratum at the well, originally saturated with water.

If the well water stands, without flow, below the top of its stratum, then the equation of flow of the well and of depression of ground water becomes

$$dh = \frac{Qdr}{2\pi r(T-h)K}, \text{ or } 2\pi(T-h)Kdh = Q \frac{dr}{r},$$

where T = thickness of stratum saturated with water with no well discharge.

Integrating, $2\pi ThK - \pi Kh^2 = Q \log r + A$,
and integrating between $r = R$ and $r = r$ and making the same assumption as above, that $Q = 2TrKS$,
then,

$$2TrKS = \left(\frac{2TH - H^2}{\log_{10} \frac{r}{R}} \right) \pi K \log_{10} \epsilon$$

or,

$$r \log_{10} \frac{r}{R} = \frac{2TH - H^2}{2TS} \pi \log_{10} \epsilon.$$

If H is small with reference to T , we may write approximately,

$$r \log_{10} \frac{r}{R} = \frac{H}{S} \pi \log_{10} \epsilon.$$

If there is no flow in the ground, then, obviously, the depression of the well will gradually increase in time, the rate of increase rapidly decreasing with the time.

With no inflow whatever, the well will derive its supply from the storage in the ground, and as, generally, this storage is of very large extent, it may be a matter of quite a period before the depression is felt over any distance. The well supply will come from the volume included between the original ground-water plane, and the plane of depression of the ground water. All the water of saturation cannot be obtained, but assuming even 20 per cent of this volume mentioned is available, it shows that the storage capacity of the soil is of very great importance.

Slichter rates wells at what he calls their specific capacity; *i.e.*, the flow per foot the well water is lowered, assuming that the rate of discharge bears a constant ratio to the lowering of the water. This is true where the lost head is lost mainly in porous media, but will not hold where the loss of head in the pipe and casing is considerable, since in the latter case the lost head varies with the square of the velocity. Slichter accordingly gives a formula based on the proportionality of head and discharge for determining the flow, from the time the well takes to fill up when pumping ceases. The formula considers the well flowing only into the net volume of the casing, deducting plunger rods, etc.

A = area in sq. ft. of well casing, minus the area of rods and pump casing, etc.

q = Specific capacity or flow in gal. per min. per ft. water is lowered.

H = Total head well is lowered by pump.

h = Instantaneous depression in feet.

t = Time in minutes since pump stopped.

Thus at any instant the flow = qh and the quantity discharged in time $dt = qh dt = 7.5 Adh$.

Hence, integrating between $h = H$ and $h = h$,

$$\frac{qt}{A} = 7.5 \log_e \left(\frac{h}{H} \right) = 17.25 \log_{10} \left(\frac{h}{H} \right).$$

Hence,
$$q = \frac{17.25 A}{t} \log_{10} \left(\frac{h}{H} \right).$$

Measuring t and h , and H and A being known, q is determined. This is an ingenious method of arriving at the flow, but it requires to be accurate, that

1. Practically all lost head must be in the porous medium.
2. The water must not be lowered in well beyond the top of the water stratum, from which it is derived.
3. There must be no other place for the returning water to flow, except into the well. In some cases it is possible that there might be some quantity of water flowing into a space where it would displace or compress air, due to the rise in pressure.
4. The well must not affect neighboring wells, or be affected thereby, should they discharge at the same time.

Methods and Cost of Boring Wells

Unlike the case of machinery for pumping, it is impossible to give even an approximate figure on the cost of boring or sinking wells, unless the nature of the strata encountered be known.

The best known form of well is the dug well, where the sides, if necessary, are curbed with wood or masonry, to prevent caving of the earth. These wells are usually comparatively shallow.

The drive well consists of pipe, on the end section of which is a strainer. The extreme end of the pipe is covered by a taper point which facilitates driving the pipe into the ground. These wells are usually not deep, on account of the difficulty of driving the pipe. The form of well most extensively used in irrigation is the bored well.

A circular hole is bored in the ground, by various means, and, if the strata encountered are liable to cave, it is cased off by iron casing. Bored wells render practical the matter of sinking to great depths.

The sizes of bored wells vary usually from 4 inches to 14 inches in diameter.

It is the usual practice in boring wells not to case the hole till necessary. The following methods of boring are in use:

1. Hand boring, by means of a long-stem auger, the débris being removed by a sand pump.

This is difficult if rock strata or boulders are encountered.

2. Drop drill. The material in the hole is smashed up by a machine-driven drop drill, and then removed by a sand pump.

3. Hydraulic sinking.

(a) The bitt, which revolves, is run by a hollow pipestem provided with a swivel joint on the top, through which water is forced down the well, coming up outside the pipe carrying the débris with it.

This method is quite rapid in a soft soil, frequently one shift making 40 feet of 6-inch hole in a day.

When passing through strata that might cave, heavy clay water is used to wall up the strata temporarily.

In sinking 6-inch wells in Southern Texas the pumps supplying water for this purpose give a flow of 60 gal. per min. under 35 to 40 pounds pressure, and about 1500 gal. per day were required to compensate for the seepage losses.

(b) The well casing is revolved and the water which is forced down it carries the débris up outside of it. This is suitable only for very soft soils, since the water does the cutting.

(c) Similar to (b), except that the casing is provided on the bottom edge with a revolving cutter which makes the hole.

This is capable of working in quite hard formations.

If it is necessary to case the well, the bottom of the casing may be left open or provided with a strainer. If left open (open-bottom well), it should stop at the top of the water stratum and should not project into it.

Well boring is usually done at a price of so much a foot for boring, plus the cost of the casing. The price per foot depends on the size of the hole, and it is usually constant up to an even number of hundred feet between 200 and 500. After that depth is passed, the cost usually increases at a given increase per foot for the next hundred feet, twice the increase for the following hundred, and so on. For example, if the cost is \$1.00 per foot up to 400 feet, it will be, say, \$1.10 from 400 to 500, and \$1.20

from 500 to 600, etc. Where well boring is an established business, 6-inch wells can usually be sunk for from 50 cents to \$1.00 per foot, for the first 200 feet, if the ground is at all favorable. With cheap labor, hydraulic rigs and a soft ground, wells 1000 feet deep can be bored at a cost between \$1.00 and 50 cents for a 6-inch well, while 12-inch wells in fairly hard strata from 800 to 1000 feet deep will cost from \$6.00 to \$12.00 a foot for boring, the cost depending on the nature of the strata.

In California 12-inch wells are commonly sunk in soft material for 50 cents per foot for the first hundred feet, and 75 cents per foot for the second hundred, \$1.00 per foot for the third hundred feet, and so on, the price being for labor only. Stovepipe casing is commonly used in 24-inch or 30-inch joints. In shallow wells single galvanized casing is used and is put on one joint at a time and riveted up when set in place. For deep wells, however, double casing is used, with inner and outer joints, lapping, and the casing often instead of being riveted is simply dented in with a pick at the joints. This casing is much cheaper than screw-joint casing and, unless the latter is made with flush joints, presents less resistance in forcing it into the ground. It will not stand as much driving, however, as screw casing, and usually is forced down by hydraulic jacks or weighted levers.

Many wells are ruined by improper casing. The artesian water is limited in quantity, and where the wells are put down without casing or are improperly cased, strata of unequal hydrostatic pressure may be thrown together, resulting in a loss of water from the higher pressure stratum, which may be seriously injurious to other wells in the same field. It is a matter of public policy to pass laws governing the sinking of wells, and the proper casing thereof, to prevent injury to neighboring wells and to endeavor to conserve the artesian supply as far as possible. Wells should be throttled when not in use, but many wells are so poorly cased that the mere additional pressure caused by throttling will open up a new passage for the water on the outside of the casing and, in some instances, the water will appear at the ground, outside the casing, and in other instances it will force its way into other strata, enlarging the leakage path, so that when the well is again turned on the yield is diminished.

In testing wells, especially where there is a deep-well pump in the well, it is frequently very difficult to measure the distance to water in the well. A method devised by the author which has given excellent results is to insert a small pipe down the well to water. By blowing down the upper end of the pipe it is possible to tell by the percussion of the bubbles exactly when the pipe enters the water.

In the case of an artesian well delivering water without pumping at the ground level, the flow is fixed. With a pumped well the flow may be varied by increasing or decreasing the depth from which the water is drawn.

Wells may be conveniently rated at the first cost in gallons per minute output. All wells will be subject to a certain annual expense, which will represent the cost of the total amount of water furnished by them. In calculations, this will be taken at 12 per cent of the first cost of all wells, composed of 7 per cent interest and taxes, and 5 per cent depreciation and repairs, the latter to include all possible costs in connection with the wells, such as sand pumping, etc., as well as depreciation due to deterioration of casing and falling off of supply, owing to increasing number of neighboring wells. The annual cost of a well is independent of the amount of water obtained from it.

The following figures were obtained from results of a large number of wells in Texas, the straight average representing the mean value per plant, and the weighted average taking the mean value of all the plants considered as a unit:

COSTS OF WELLS AND OF WELL WATER IN SOUTHERN TEXAS.

	Artesian well	Pumped well
First Cost :		
Average cost per gal. per min. (straight average) .	\$21 .62	\$6 .13
Average cost per gal. per min. (weighted average) .	8 .30	2 .75
Average cost per acre irrigated (straight average) .	71 .00	15 .25
Average cost per acre irrigated (weighted average) .	57 .77	14 .79
Annual cost per acre irrigated (straight average) . .	8 .63	...
*Average cost per acre-foot output (straight average)	2 .86	...

* This is the cost of water actually used in irrigation. The irrigation factor was 20 per cent.

The wide difference between the straight and weighted average is due to the high cost of some of the small wells. Pumped

wells, in general, are much more shallow than artesian wells, and hence cost far less.

It is a common belief that artesian well water costs nothing. This is, of course, erroneous, since even if the repairs, renewals and possible falling off of water supply be disregarded, the interest on the investment still runs on. Of course, it is highly desirable to obtain water without the operating expense of a pumping plant. Still the first cost may be so high that a pumping plant operating under low head may easily be a better investment than a deep artesian well. Table L and curves in Fig. 51 show the relation between the irrigation factor, the cost per gallon per minute of artesian wells, and the cost of water per acre-foot, based on 12 per cent annual expense. One gallon per minute will deliver 1.612 acre-feet per year, and, at a cost of \$10 per gal. per min. and 100 per cent irrigation factor, will cost 75 cents per acre-foot.

CHAPTER IX.

PUMPS AND PUMPING MACHINERY.

THE power required in pumping water is usually reckoned in horsepower. One horsepower will lift 3960 gals. 1 ft. per min., or 8.33 cu. ft. 1 ft. per sec. Hence, to find the actual horsepower for a given lift, multiply the feet vertical lift by the flow in gallons per minute, and divide by 3960, or else multiply the feet lift by the flow in cubic feet per second and divide by 8.83. The result is the net horsepower required for actual and useful work.

In order to force water through suction and discharge piping, and around bends, etc., requires the expenditure of additional energy which must be furnished by the pump. The energy so required is equivalent to that consumed in raising the water to an additional height, which added height would be required to overcome all pipe losses. This added height is known as the head lost in the piping, and may be calculated when the sizes of piping, etc., are known. Hence, to find the power which the pump must furnish, the lost head in feet must be added to the vertical lift to find the total head against which the pump must operate. Multiplying this head by the flow, and dividing by the appropriate constant, as given above, gives the power which must be furnished by the pump, known as the pump output. The engine must deliver to the pump sufficient power to supply this output, and also to supply losses of power in the pump. Hence, to obtain the required power of engine, the pump output should be divided by the pump efficiency. The latter will range, as a rule, from 30 per cent to 80 per cent, depending on the size and type of pump and on the conditions of operation. Fifty per cent is usually a safe figure. On this basis multiply head in feet by the gallons per minute flow, and divide by 2000, to get the horsepower required to drive the pump. Table XXVI will facilitate calculations of this sort.

TABLE XXVI.—PUMP POWER.

Cu. ft. per sec. times head in ft.	Gal. per min. times head in ft.	Water horse-power.	Motor horsepower required at percentage pump efficiency of												
			90.	85.	80.	75.	70.	65.	60.	55.	50.	45.	40.	35.	30.
8.83	3,960	1.0	1.11	1.18	1.25	1.33	1.43	1.54	1.67	1.82	2.00	2.22	2.50	2.86	3.33
9.71	4,360	1.1	1.22	1.30	1.38	1.47	1.57	1.69	1.84	2.00	2.20	2.44	2.75	3.14	3.67
10.59	4,750	1.2	1.33	1.41	1.50	1.60	1.71	1.85	2.00	2.18	2.40	2.67	3.00	3.43	4.00
11.47	5,150	1.3	1.44	1.53	1.63	1.73	1.86	2.00	2.17	2.36	2.60	2.89	3.25	3.71	4.33
12.35	5,550	1.4	1.55	1.65	1.75	1.87	2.00	2.15	2.34	2.55	2.80	3.11	3.50	4.00	4.67
13.24	5,940	1.5	1.67	1.77	1.88	2.00	2.14	2.31	2.50	2.73	3.00	3.33	3.75	4.28	5.00
14.12	6,330	1.6	1.78	1.88	2.00	2.14	2.29	2.43	2.67	2.91	3.20	3.56	4.00	4.57	5.33
15.00	6,730	1.7	1.89	2.00	2.13	2.27	2.43	2.61	2.84	3.09	3.40	3.78	4.25	4.86	5.67
15.88	7,130	1.8	2.00	2.12	2.25	2.40	2.57	2.77	3.00	3.28	3.60	4.00	4.50	5.14	6.00
16.77	7,520	1.9	2.11	2.24	2.38	2.54	2.72	2.92	3.17	3.46	3.80	4.22	4.75	5.43	6.33
17.65	7,920	2.0	2.22	2.36	2.50	2.67	2.86	3.08	3.34	3.64	4.00	4.44	5.00	5.72	6.67
18.52	8,310	2.1	2.44	2.59	2.75	2.94	3.14	3.38	3.67	4.00	4.40	4.89	5.50	6.28	7.33
19.42	8,710	2.2	2.67	2.82	3.00	3.20	3.43	3.69	4.00	4.37	4.80	5.33	6.00	6.86	8.00
21.18	9,500	2.4	2.89	3.06	3.25	3.47	3.71	4.00	4.33	4.73	5.20	5.78	6.50	7.43	8.67
24.72	11,090	2.8	3.11	3.30	3.50	3.74	4.00	4.31	4.67	5.09	5.60	6.12	7.00	8.00	9.33
26.48	11,880	3.0	3.33	3.54	3.75	4.00	4.28	4.62	5.00	5.46	6.00	6.67	7.50	8.57	10.00
28.26	12,670	3.2	3.55	3.77	4.00	4.27	4.57	4.92	5.33	5.82	6.40	7.12	8.00	9.14	10.70
30.00	13,460	3.4	3.78	4.00	4.25	4.53	4.86	5.23	5.67	6.18	6.80	7.56	8.50	9.72	11.30
31.80	14,260	3.6	4.00	4.23	4.50	4.80	5.14	5.53	6.00	6.55	7.20	8.00	9.00	10.30	12.00
33.50	15,050	3.8	4.22	4.47	4.75	5.07	5.43	5.84	6.33	6.91	7.60	8.44	9.50	10.90	12.70
35.30	15,840	4.0	4.44	4.71	5.00	5.33	5.71	6.15	6.67	7.27	8.00	8.89	10.00	11.40	13.30
39.70	17,830	4.5	5.00	5.30	5.63	6.00	6.43	6.92	7.50	8.18	9.00	10.00	11.30	12.80	15.00
44.10	19,800	5.0	5.55	5.89	6.25	6.67	7.14	7.68	8.33	9.10	10.00	11.10	12.50	14.30	16.70
48.50	21,800	5.5	6.11	6.43	6.88	7.33	7.86	8.46	9.17	10.00	11.00	12.20	13.80	15.70	18.30
52.90	23,760	6.0	6.67	7.06	7.50	8.00	8.57	9.23	10.00	10.90	12.00	13.30	15.00	17.10	20.00
57.40	25,750	6.5	7.23	7.65	8.13	8.67	9.28	10.00	10.80	11.80	13.00	14.50	16.30	18.60	21.70
61.80	27,750	7.0	7.78	8.23	8.75	9.33	10.00	10.80	11.70	12.80	14.00	15.60	17.50	20.00	23.40
66.20	29,720	7.5	8.33	8.83	9.38	10.00	10.70	11.50	12.50	13.60	15.00	16.70	18.80	21.40	25.00
70.60	31,700	8.0	8.88	9.42	10.00	10.70	11.40	12.30	13.30	14.50	16.00	17.80	20.00	22.80	26.70
75.00	33,700	8.5	9.44	10.00	10.60	11.30	12.10	13.10	14.20	15.50	17.00	18.90	21.30	24.30	28.40
79.40	35,700	9.0	10.00	10.60	11.30	12.00	12.80	13.80	15.00	16.40	18.00	20.00	22.50	25.70	30.00
83.80	37,600	9.5	10.60	11.20	11.90	12.70	13.60	14.60	15.80	17.30	19.00	21.10	23.80	27.10	31.70

Column 1 gives ft. lift \times cu. ft. per sec.

Column 2 gives ft. lift \times gal. per min.

Column 3 gives water horsepower at 100 per cent efficiency.

Columns 4 to 16 give engine horsepower at various efficiencies.

To lift 1 acre-foot of water 1 foot requires the expenditure of 1.37 water horsepower-hours. This may be conveniently used in calculation of total quantities of energy required in the irrigation of land. To illustrate the use of Table IX, what horsepower engine must be provided to lift 700 gal. per min. a height of 70 feet, the friction and other losses in piping being 20 feet, with a pump of 60 per cent efficiency. The total head is 90 ft., and $90 \times 700 = 63,000$. Looking under the second column, 6330 gal. per min. \times ft. require at 60 per cent efficiency 2.67 horsepower. Hence, required power of the engine = 26.6 horsepower.

In consideration of the lift of the pump there is often some confusion with regard to the exact meaning of this term. Distinction must be made between the lift of the pump and the total head against which the pump must operate. The head is equal to the lift, plus all the losses in friction, entrance to pipes, curves, and discharge from the outlet of the piping. The ratio of the lift to the head we shall call the efficiency of the piping. To illustrate this, in Fig. 25, let

- S = suction lift
- P = pressure lift
- L = total lift = $S + P + C$
- H_s = suction head
- H_p = pressure head
- H = total head

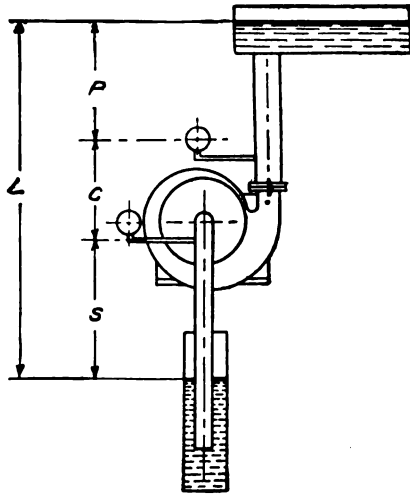

Fig. 25. Diagram of Pump Lift.

F_s = sum of the losses of head occurring in suction pipe and in entrance to the same.

F_p = loss of head in discharge pipe, due to friction, etc.

G_s = gauge reading of suction pipe, the suction head being considered positive.

G_p = reading of pressure gauge.

C = vertical distance from suction-gauge tap to center of pressure gauge.

V_s = velocity of flow in feet per second in suction pipe at the point of suction-gauge tap.

V_p = velocity in feet per second in pipe at pressure-gauge tap.

V_o = velocity in feet per second at discharge end of pipe.

$$\text{Then, } H_s = S + F_s + \frac{(V_s)^2}{2g} = G_s,$$

$$H_p = P + C + F_p + \frac{V_o^2}{2g} = G_p + C + \frac{V_p^2}{2g},$$

$$\begin{aligned} H_s + H_p - \frac{V_s^2}{2g} &= H = S + F_s + P + F_p + \frac{V_o^2}{2g} + C \\ &= G_s + G_p + C + \frac{V_p^2}{2g} - \frac{V_s^2}{2g}. \end{aligned}$$

All pressures are in feet of water. The efficiency of piping $= \frac{H}{L}$. In the case shown, which represents pumping from a well or from a sump, the meaning of the term "lift" is perfectly obvious, representing a total difference of elevation between the level of water in the sump of well and the level of the discharge water. However, in the event of pumping from a well when the suction pipe is directly attached to the well casing, the term "lift" is indefinite, though the total head may be defined as before, as well as the suction and discharge heads. In selecting a pump, the head against which it must operate, and not the lift, is of course to be considered. If the pipes where the pressure and suction gauges respectively are tapped

are of the same diameter, $V_s = V_p$, hence the total head is equal to the sum of the gauge readings + C .

In making efficiency tests of a pump care should be taken not to charge losses in suction or discharge pipes or in the velocity of discharge, against the pump itself. These losses belong directly to the piping and have no connection whatever with the pump efficiency. If the total lift, L , be known, the pipe efficiency may be calculated from the data, or else may be measured by the aid of gauges, as shown in the figure. It should be noted that, assuming a negative pressure in the suction pipe, no water will stand in the pipe leading to the suction gauge, hence the gauge reading refers to the level of the suction pipe where tapped. With reference to the pressure-pipe gauge tap, however, such is not the case, the pressure-gauge pipe being filled with water. If the pressure pipe should be of any appreciable length, care should be taken to see that water fills the pipe up to the gauge, in order that air trapped in the pipe may not leave the actual level of water in the gauge pipe in doubt. Should there be a positive pressure in the suction pipe, similar precautions should be taken for the suction-gauge piping. In this event, C would represent the vertical difference between gauge centers instead of the difference of level between center of pressure gauge and the point of suction tap. Pressure or suction gauges should be located on a straight section of the pipe, as near the pump as possible, but where the water is moving at a uniform velocity. In case the head against which the pump operates is low, particular attention should be given to the details already mentioned, since, if disregarded, the same might lead to very large errors in the results. In making accurate tests of low-head pumps, some form of liquid gauge would usually be preferable to commercial gauges commonly used. In reckoning the losses in the pipe, the friction losses, loss of head at entrance to the suction pipes, and the velocity head of the discharge pipe, as well as losses due to sudden bends of pipe, or sudden change in the section thereof, must be computed, in event of the lift alone being known. To facilitate computation of this kind, Table XXVII shows the losses in friction, as well as the velocity heads for various sized pipes delivering water at different rates. The velocity head in feet is equal to the square of the velocity at the point in question divided by $2g$, g equaling 32.2. The

loss of head at the entrance to a pipe projecting into a body of water is equal to one-half the velocity head at that point and the loss at the end of the pipe, where the same discharges, equals the velocity head at that point.

TABLE XXVII.
VELOCITY AND FRICTION HEAD TABLES IN NEW CAST IRON PIPES.
(Based on Cor's Formula, see page 228, Appendix.)

Veloc- ity	Velocity head	2-inch pipe		3-inch pipe		4-inch pipe	
		Flow	Friction loss per 1,000 ft.	Flow	Friction loss per 1,000 ft.	Flow	Friction loss per 1,000 ft.
Ft. per sec.	Ft.	Gal. per min.	Ft.	Gal. per min.	Ft.	Gal. per min.	Ft.
1	.02	10	2.9	22	1.9	39	1.5
2	.06	20	10.0	44	6.7	78	5.0
3	.14	29	20.4	66	13.6	117	10.2
4	.25	39	34.1	88	22.8	157	17.1
5	.39	49	51.3	110	34.1	196	25.6
6	.56	59	71.8	132	47.8	235	35.8
7	.76	69	95.5	154	63.6	274	47.7
8	.99	78	122	176	81.6	313	61.2
9	1.26	88	153	198	102	352	76.5
10	1.55	98	187	221	124	392	93.5
11	1.88	108	224	243	149	431	112
12	2.24	117	264	265	176	470	132
13	2.63	127	308	287	205	509	154
14	3.05	137	355	309	236	549	177
15	3.50	147	405	331	270	588	202
16	3.97	156	460	353	306	627	230
17	4.50	166	517	375	344	666	258
		5-inch pipe		6-inch pipe		7-inch pipe	
1	.02	61	1.2	88	1.0	120	0.84
2	.06	122	4.0	176	3.3	240	2.9
3	.14	183	8.2	265	6.8	360	5.8
4	.25	245	13.7	353	11.4	480	9.8
5	.39	306	20.5	441	17.1	600	14.6
6	.56	367	28.7	530	23.9	720	20.5
7	.76	429	38.1	628	31.7	840	27.2
8	.99	489	49.0	706	40.8	960	35.0
9	1.26	551	61.1	794	51.0	1 080	43.7
10	1.55	612	74.8	883	62.2	1 200	53.3
11	1.88	673	89.5	970	75.7	1 320	64.0
12	2.24	734	106	1,059	88.2	1 440	75.6
13	2.63	795	123	1,146	103	1 560	88.0
14	3.05	857	142	1,235	118	1 680	102
15	3.50	918	162	1,322	135	1 800	116
16	3.97	979	184	1,411	153	1 920	131
17	4.50	1,040	206	1,500	172	2 040	148

TABLE XXVII—Continued.

Velocity	Velocity head	8-inch pipe		9-inch pipe		10-inch pipe	
		Flow	Friction loss per 1,000 ft.	Flow	Friction loss per 1,000 ft.	Flow	Friction loss per 1,000 ft.
		Ft. per sec.	Ft.	Gal. per min.	Ft.	Gal. per min.	Ft.
1	.02	157	.73	198	0.65	245	0.58
2	.06	313	2.5	397	2.2	490	2.00
3	.14	470	5.1	595	4.5	735	4.17
4	.25	628	8.6	794	7.6	980	6.8
5	.39	784	12.8	993	11.4	1,225	10.2
6	.56	941	17.9	1,190	15.9	1,470	14.6
7	.76	1,095	23.8	1,389	21.2	1,715	19.1
8	.99	1,252	30.6	1,587	27.2	1,960	24.5
9	1.26	1,409	38.3	1,786	34.0	2,205	30.6
10	1.55	1,567	46.7	1,984	41.5	2,450	37.3
11	1.88	1,724	56.0	2,182	49.7	2,695	44.8
12	2.24	1,881	66.1	2,380	58.7	2,940	52.8
13	2.63	2,037	77.0	2,579	68.4	3,185	61.6
14	3.05	2,195	88.8	2,777	78.9	3,430	71.0
15	3.50	2,350	101	2,976	90.2	3,675	81.1
16	3.97	2,507	115	3,175	102	3,920	91.8
17	4.50	2,664	129	3,373	115	4,165	103
		11-inch pipe		12-inch pipe		13-in. pipe	
1	.02	296	0.53	353	0.49	414	0.45
2	.06	592	1.82	707	1.67	828	1.54
3	.14	889	3.71	1,160	3.40	1,221	3.14
4	.25	1,185	6.2	1,413	5.7	1,655	5.27
5	.39	1,482	9.3	1,766	8.5	2,068	7.9
6	.56	1,777	13.0	2,120	11.9	2,482	11.0
7	.76	2,075	17.3	2,472	15.9	2,896	14.7
8	.99	2,350	22.2	2,816	20.4	3,310	18.8
9	1.26	2,665	27.8	3,180	25.5	3,720	23.5
10	1.55	2,964	33.9	3,530	31.1	4,140	28.7
11	1.88	3,260	40.7	3,870	37.2	4,550	34.4
12	2.24	3,560	48.0	4,240	44.0	4,970	40.6
13	2.63	3,850	56.0	4,590	51.3	5,380	47.3
14	3.05	4,150	64.6	4,950	59.1	5,800	54.6
15	3.50	4,450	73.7	5,300	67.6	6,210	62.3
16	3.97	4,740	83.5	5,650	76.5	6,630	70.6
17	4.50	5,040	94.0	6,000	86.2	7,040	79.5

TABLE XXVII—Continued.

Velocity	Velocity head	14-inch pipe		15-inch pipe		16-inch pipe	
		Flow	Friction loss per 1,000 ft.	Flow	Friction loss per 1,000 ft.	Flow	Friction loss per 1,000 ft.
		Ft. per sec.	Ft.	Gal. per min.	Ft.	Gal. per min.	Ft.
1	.02	480	0.42	552	0.39	628	0.36
2	.06	960	1.43	1,103	1.33	1,255	1.25
3	.14	1,440	2.92	1,655	2.72	1,882	2.55
4	.25	1,920	4.88	2,207	4.56	2,510	4.27
5	.39	2,400	7.3	2,760	6.8	3,140	6.4
6	.56	2,880	10.2	3,130	9.6	3,760	9.0
7	.76	3,360	13.6	3,310	12.7	4,390	11.9
8	.99	3,840	17.5	3,860	16.3	5,020	15.3
9	1.26	4,320	21.8	4,410	20.4	5,650	19.1
10	1.55	4,800	26.6	5,520	24.9	6,280	23.3
11	1.88	5,280	31.9	6,170	29.8	6,900	28.0
12	2.24	5,760	37.7	6,620	35.2	7,530	33.0
13	2.63	6,240	44.0	7,180	41.0	8,160	38.4
14	3.05	6,720	50.7	7,730	47.3	8,790	44.3
15	3.50	7,200	57.9	8,280	54.1	9,420	50.7
16	3.97	7,680	65.6	8,840	61.1	10,030	57.3
17	4.50	8,170	73.9	9,390	68.9	10,680	64.7
		18-inch pipe		20-inch pipe		22-inch pipe	
1	.02	794	0.32	980	0.29	1,187	0.26
2	.06	1,588	1.11	1,960	1.00	2,375	0.91
3	.14	2,381	2.27	2,940	2.04	3,560	1.85
4	.25	3,170	3.80	3,920	3.42	4,750	3.11
5	.39	3,970	5.7	4,900	5.1	5,940	4.64
6	.56	4,760	8.0	5,880	7.2	7,120	6.5
7	.76	5,550	10.6	6,860	9.5	8,310	8.7
8	.99	6,350	13.6	7,840	12.2	9,500	11.1
9	1.26	7,150	17.0	8,820	15.3	10,680	13.9
10	1.55	7,940	20.7	9,800	18.7	11,870	17.0
11	1.88	8,730	24.8	10,780	22.4	13,060	20.3
12	2.24	9,530	29.4	11,760	26.4	14,240	24.0
13	2.63	10,310	34.2	12,740	30.7	15,420	28.0
14	3.05	11,100	39.4	13,720	35.5	16,610	32.3
15	3.50	11,900	45.0	14,700	40.5	17,700	36.8
16	3.97	12,700	51.0	15,680	45.9	18,990	41.7
17	4.50	13,490	57.5	16,660	51.7	20,180	47.0

TABLE XXVII—Continued.

Velocity	Velocity head	24-inch pipe		26-inch pipe		28-inch pipe	
		Flow	Friction loss per 1,000 ft.	Flow	Friction loss per 1,000 ft.	Flow	Friction loss per 1,000 ft.
		Ft. per sec.	Ft.	Gal. per min.	Ft.	Gal. per min.	Ft.
1	.02	1,413	0.24	1,657	0.22	1,921	0.21
2	.06	2,827	0.83	3,310	0.77	3,840	0.72
3	.14	4,240	1.70	4,970	1.57	5,770	1.46
4	.25	5,650	2.85	6,630	2.63	7,690	2.44
5	.39	7,070	4.26	8,290	3.94	9,610	3.65
6	.56	8,480	6.0	9,950	5.5	11,520	5.1
7	.76	9,900	8.0	11,600	7.3	13,440	6.8
8	.99	11,300	10.2	13,250	9.3	15,360	8.7
9	1.26	12,710	12.7	14,910	11.8	17,280	10.9
10	1.55	14,130	15.5	16,570	14.4	19,210	13.3
11	1.88	15,550	18.6	18,230	17.2	21,150	16.0
12	2.24	16,960	22.0	19,880	20.3	23,050	18.9
13	2.63	18,380	25.6	21,550	23.7	24,970	22.0
14	3.05	19,790	29.5	23,200	27.3	26,900	25.3
15	3.50	21,200	33.8	24,870	31.2	28,820	28.9
16	3.97	22,620	38.2	26,530	35.3	31,700	32.7
17	4.50	24,030	43.0	28,180	39.3	32,700	36.9
		30-inch pipe		36-inch pipe		42-inch pipe	
1	.02	2,204	0.19	3,180	0.16	4,310	0.14
2	.06	4,410	0.67	6,360	0.56	8,630	0.48
3	.14	6,620	1.36	9,540	1.13	12,940	0.97
4	.25	8,830	2.28	12,700	1.90	17,280	1.63
5	.39	11,020	3.41	15,870	2.84	21,580	2.43
6	.56	13,230	4.78	19,050	3.98	25,900	3.41
7	.76	15,430	6.4	22,230	5.3	30,200	4.54
8	.99	17,650	8.2	25,400	6.8	34,500	5.8
9	1.26	19,850	10.2	28,600	8.5	38,900	7.3
10	1.55	22,040	12.4	31,800	10.4	43,100	8.9
11	1.88	24,260	14.9	35,000	12.4	47,500	10.6
12	2.24	26,470	17.6	38,100	14.7	51,800	12.6
13	2.63	28,670	20.5	41,300	17.1	56,100	14.7
14	3.05	30,900	23.7	44,500	19.7	60,500	16.9
15	3.50	33,100	27.0	47,700	22.5	64,800	19.3
16	3.97	35,300	30.5	50,800	25.5	69,100	21.8
17	4.50	37,500	34.4	54,000	28.7	73,400	24.6

TABLE XXVII — *Concluded.*

Velocity	Velocity head	48-inch pipe		60-inch pipe	
		Flow	Friction loss per 1,000 ft.	Flow	Friction loss per 1,000 ft.
	Ft. per sec.	Ft.	Gal. per min.	Ft.	Gal. per min.
1	.02	5,640	0.12	8,830	0.10
2	.06	11,290	0.42	17,650	0.33
3	.14	16,940	0.85	26,480	0.68
4	.25	22,600	1.43	35,300	1.14
5	.39	28,230	2.13	44,100	1.70
6	.56	33,900	2.98	53,000	2.39
7	.76	39,500	3.98	62,800	3.18
8	.99	45,200	5.1	70,600	4.08
9	1.26	50,800	6.4	79,400	5.1
10	1.55	56,400	7.8	88,300	6.2
11	1.88	62,100	9.3	97,000	7.5
12	2.24	67,800	11.0	105,900	8.8
13	2.63	73,400	12.8	114,600	10.3
14	3.05	79,100	14.8	123,500	11.8
15	3.50	84,700	16.9	132,200	13.5
16	3.97	90,400	19.1	141,100	15.3
17	4.50	96,000	21.5	150,000	17.2

With low-head plants the possible losses in both the entrance to the suction piping and in the velocity head lost in the discharge should be carefully considered, as they may easily add very materially to the power required for pumping. These losses can be obviated with such simple and cheap means that there seems little reason for their existence. The head lost in entrance to the suction pipe can be easily avoided by bellng the pipe at the entrance. A bell-shaped entrance is preferable to a cone-shaped, though the latter will often be a decided improvement over the straight pipe.

With reference to the discharge pipe, a taper joint with gradually enlarging section will overcome almost entirely the loss of head at the discharge. Since the loss of discharge head varies with the fourth power of the diameter, by increasing the diameter 42 per cent, the discharge loss can be reduced to one-fourth of its previous value, and by doubling the diameter, can be reduced to one-sixteenth of its previous value.

It is no uncommon sight to find discharge pipes in irrigation plants throwing the water into the air several feet above the

level of the discharged water, owing to the high velocity heads. It is obvious to even a casual observer that this represents a considerable loss of power. Of course it is unnecessary in many cases to go to the trouble of endeavoring to avoid these losses, provided they are not of sufficient importance to warrant so doing. From Table XXVII, one can judge whether it would pay to take the precautions necessary to obviate entrance and discharge losses.

Of recent years there has been a decided increase in the use of irrigation pumping stations. This has been brought about mainly owing to three reasons:

1. Decreased cost of energy.
2. Improvements in pumps.
3. Settlement of lands where irrigation is a commercial necessity. Much land now arid can be successfully irrigated by pump water, but the results of an undertaking of this nature are dependent on so many circumstances that a proper selection of apparatus and understanding of conditions will often tip the balance from failure to success.

One important element of success in many cases is the reduction of the labor required for the operation of the stations. Labor often forms a large proportion of the cost of pumping, and any means by which it can be reduced is of importance. Skilled labor should be used only where necessary, as much of the work of operation may be performed by unskilled workmen provided there be a proper organization and superintendence.

Having determined the desired capacity of pump station as previously outlined, the next consideration is the available amount of water, and the depth from which it must be raised, as well as the possible variations in the same, due to dry years, change of season, and the other plants in the vicinity. If the irrigation water is derived from wells, most of this information can be obtained only by experiment, though often an approximate idea can be obtained from wells near by. Before going to the expense of installing a well pumping station, wells should first be tested for capacity.

The motive power to be adopted depends on the location and capacity of the plant, the required hours of operation, the cost of labor and fuel. If a number of plants are to be operated in the same vicinity, it may often pay to put in a central electric

station, and to distribute energy therefrom to the various plants, rather than to have each station provided with its own source of energy. The distance to which energy may be economically transmitted by electricity, even in small quantities, is surprisingly large.* As an illustration, estimates on various plans for the operation of 120-stock water pump stations with a maximum probable demand of 90 horsepower showed that, although the first cost was higher, still electrical operation of the plant figured out cheaper than any other plan. It involved the use of 120 miles of pole line and of a complete telephone system. Each station was to contain a motor, small centrifugal pump, telephone, automatic float, operating a switch for starting and stopping the motor, earth reservoir, and float valves for letting water into the watering troughs. The plans also involved a brick power house for generating electricity. The estimated cost of complete installation was \$60,000, or about \$500 per station.

While not the cheapest system to install, yet, in this instance, the operation was far cheaper than by any other system.

It would have been cheaper to have installed gasoline engines, but the operating expense, mainly of attendance, would have been too high to have justified such an installation.

For small individual pumping plants, requiring a few horsepower, a gasoline engine is frequently the best form of motive power. The oil cups on the engine and pump should be made of ample size, so that the apparatus can run for hours without attendance, without danger of accident. For fuel, some of the better grades of distillate can be used instead of gasoline, thus making a decided saving in cost. Distillate is made from crude oil, and consists of the more volatile parts of the oil, which are driven off by heat and then condensed.

Local conditions, of course, largely govern the kind of fuel to be used, but the cheapest fuel is not necessarily the most economical.

The expense of firing and of handling the fuel may cut a large figure in the actual cost of power, and it may be found that oil, even if more expensive than other kinds of fuel, may reduce the operating expenses of the plant sufficiently to justify its adoption. This, of course, applies to stations of some size, as with

* See paper by the author, Transactions Pacific Coast Transmission Association, 1902.

smaller stations, which can be easily operated by one man, there is no saving in the matter of attendance.

There is such a wide difference between the values of different grades of coal that the price per ton should by no means determine the kind to be used. Some of the poor grades of coal have not one-third of the steaming value of the better grades, and they reduce considerably the power available from the boilers, as well as increasing largely the work of the firemen. A good coal will contain as high as 14,000 British thermal units per pound, while some grades of poor coal have less than 5000 British thermal units per pound.

Among the various kinds of pumps and methods of pumping in most common use in irrigation pumping, may be mentioned the following:

1. Deep well pumps.
2. Power plunger pumps.
3. Pumping engines.
4. Direct-acting steam pumps.
5. Pulsometer.
6. Air lift.
7. Centrifugal pump.
8. Hydraulic ram.

1. In pumping from wells where the lift is high, the distance to ground water considerable, the flow of water is small, and the water is free from grit or sand, the deep-well pump is usually to be preferred. It has the advantage that it may be conveniently located inside a well, thus dispensing with digging a pit.

2. Power plunger pumps may be used to advantage where the lift is high, and the pump may be located so that it is not in danger of being submerged, and there is no danger of water going below the suction limit.

3. Pumping engines may be used to advantage where the quantity of water is large and the lift high. They are capable of giving excellent results for economy, but their field is usually for city water works, rather than for irrigation plants.

4. Direct-acting steam pumps, while possessing the element of simplicity, still consume a large amount of steam, and are quite inefficient in fuel consumption. Their low first cost is usually offset by increased boiler capacity. Compounding

these pumps results in a considerable saving in steam, but is an additional expense.

5. The pulsometer, while simple in construction, is subject to the same objections as direct-acting pumps, being a heavy steam consumer.

6. The air lift, while not an efficient method of pumping, has still many advantages for certain kinds of deep-well pumping. It enables water to be drawn from a considerable depth, and is capable of handling a large quantity of water to better advantage than can be done by a deep-well pump. It has all its working parts above the well, easily accessible, and is not troubled by sand and grit in the well getting into the valves. If several wells in the same vicinity were to be pumped by compressed air, it might pay to install a central air station and to pipe the air to the different wells. To get any sort of efficiency out of an air lift requires a submergence of the air pipe at least equal to the lift, and preferably twice as great.

7. For pumping plants of any size, the centrifugal pump is generally the most desirable pump to install. It has the combination of cheapness, simplicity, and a minimum of working parts. It has no valves to give trouble, and can handle water with grit without getting out of order, though, of course, the wear is increased in that case. The improvements in the centrifugal pump have contributed largely to the increase in irrigation pumping. Good results as regards efficiency may be obtained by the proper use of these pumps as now constructed by the leading manufacturers. Unfortunately, the laws of centrifugal pumps are little understood by many who should be better informed on this subject, and the result has been that many of them, as installed, are not working at anything like their highest efficiency. The proper speed at which to run a centrifugal pump varies with the square root of the head, the latter including both friction and other losses of head and the actual lift. *The efficient capacity of a centrifugal pump, when operating at its efficient speed, for a given lift, varies directly with the speed,* and is not constant. Most centrifugal pump manufacturers make the serious mistake of rating their pumps at a fixed capacity.

A centrifugal pump can be rated efficiently at a given capacity only when the head, and hence the speed too, is fixed.

8. In the hydraulic ram the energy of a considerable quantity of water falling a moderate distance is made to force part of the water to an elevation. The ram requires very little attention, and in some instances is quite economical. It is usually used in small installations.

Cost of Engines, Motors, and Pumps.

The cost of pumping machinery will vary with the grade of machinery and with the location of the plant, owing to freight charges. It is often desirable to figure the approximate cost of machinery without going too much into detail, and the following figures will give approximate prices.

TABLE XXVIII.
COST OF GASOLINE ENGINES.

Brake horsepower	Cost	Cost per horsepower
1	\$125	\$125
2	225	112
3	300	100
4	370	92
5	420	82
10	640	64
20	1000	50
50	2200	44
100	3500	35

Actual prices may vary from 10 to 20 per cent from these costs.

Steam engines are usually rated by indicated horsepower; *i.e.*, the power developed in the engine cylinder. To get the actual available horsepower output (brake horsepower), the mechanical losses of friction and windage must be deducted from the indicated horsepower. The mechanical efficiency of engines will usually lie between 85 and 92 per cent. Simple engines will cost from \$8 to \$15 per indicated horsepower, and compound engines from \$12 to \$25.

Horizontal tubular boilers will cost from \$6 to \$13 per boiler horsepower, and water tube boilers from \$14 to \$18 per boiler horsepower.

The setting for boilers will cost from \$3 to \$6 per boiler horsepower exclusive of foundations. Pumps and heaters will cost per

boiler horsepower from \$2 for noncondensing up to \$5 for condensing plants. To these costs must be added the cost of stock, foundations, pumps and building, as well as the cost of installing the plant. As a rule, irrigation pumping plants of small or moderate size employ cheap engines and boilers, and hence the cost of the plants will be nearer the lower than the higher limits given below. In general, the use of compound engines and of condensers will considerably increase the cost of plant, though allowing smaller boilers and more economical use of fuel. The following figures will give an approximate idea of the cost of steam plants per indicated horsepower, the higher limits representing high-grade machinery not usually employed.

TABLE XXVIIIa.
COST OF STEAM PLANTS.

Size plant indicated horsepower	5.	10.	25.	50.	100.	200.	500.
Total cost of steam plant per indicated horsepower —							
From	\$95	75	55	60	50	47	42
To	180	160	108	120	100	90	80

To these costs must be added the cost of hydraulic development and the cost of irrigation pumps.

In general, irrigation pumping stations will cost from \$60 to \$150 per brake horsepower for plants of 15 horsepower and over, depending on the size of plant, type of machinery, and cost of water development (*i.e.*, wells, pipe line, or reservoir cost).

The approximate cost of polyphase induction motors for motors of 500 volts and under, is given in the following table.

The actual prices may vary from 10 to 20 per cent from these figures. The price of a motor will depend on the speed, and will increase rapidly with decrease of speed.

Centrifugal pumps of the same nominal size, as built by different makers, have different capacities. It has been pointed out that it is wrong to rate centrifugal pumps at a constant output independent of speed, and that the proper output varies directly as the speed suitable for the head. Of course pumps if run at a sufficient speed will deliver flows dependent on the heads against which they operate, but then their rating should be only at or near their highest efficiency.

TABLE XXVIII.
 COST OF POLYPHASE 60-CYCLE MOTORS FOR VOLTAGES
 FROM 100 TO 500.

Horsepower	Cost	Cost per hp.	Speed r.p.m.
1	\$55	\$55.00	1800
2	80	40.00	1800
5	100	20.00	1800
10	240	24.00	1200
20	375	18.75	1200
30	425	14.17	1200
50	600	12.00	900
75	900	12.00	720
100	1080	10.80	720
150	1500	10.00	580
200	1830	9.15	580
300	2650	8.83	580

TABLE XXIX.
 THE APPROXIMATE COSTS AND CAPACITIES UNDER 40 FOOT
 HEAD OF CENTRIFUGAL PUMPS.

No. Pump	Gal. per min.	Cost
4	450	\$95
6	900	150
8	1600	220
10	2500	300
12	4000	380

The cost of pumping water may be regarded as composed of three different parts:

1. Expense for fuel or energy.

This cost is generally directly proportional to the quantity of water pumped.

2. Labor expense for operation of the plant. This cost is generally proportional to the hours of operation. However, it is in reality proportional to the length of irrigation season, since generally labor for operation of pumps cannot be engaged by the day for the mere time when the pumps are in operation, but must be paid for the entire irrigation season.

In some farms, however, the engineer will do other work around the farm when the pumps are shut down for any reason.

3. The remaining expenses, while not strictly of such a nature, may be conveniently regarded under the head of fixed expense bearing annually a certain proportion to the total cost of the plant.

The fixed expense may be segregated under the following heads:

- (a) Interest and taxes.
- (b) Depreciation.
- (c) Repairs and renewals.
- (d) Supplies for operation.

(a) Interest and taxes are independent of time or hours of operation. Seven per cent of first cost may be taken as a fair value for the same.

(b) Depreciation. — The value of depreciation is in part dependent on the time of operation. Without care machinery will depreciate as fast from disuse due to rusting, as it will from wear. The annual depreciation of most irrigation plants is largely due to lack of care and insufficient housing of machinery, which is often left exposed to the elements.

Depreciation will vary from about 2 per cent to 30 per cent per year, depending on the use or abuse of machinery; but 8 to 10 per cent should cover depreciation in most cases, if reasonable attention be given to it.

(c) Repairs and renewals will vary from 2 per cent to 20 per cent, and 2 per cent should cover supplies for operation.

With moderate care the following figures should give fair values of fixed expenses.

	Per cent
Interest and taxes	7
Depreciation	8
Repairs and renewals	3
Supplies	2
	20

If conditions are exceptionally favorable, this figure may be as low as 14 per cent. These figures apply to the pumping plant proper. The total fixed expenses for pipe lines, wells, and artificial reservoirs is much less and approximately may be taken at 12 per cent.

Hence it is evident that the cost of pumping a unit quantity of water is composed of the following three parts:

1. Fuel expense, directly proportional to the quantities pumped.
2. Labor expense, directly proportional to length of irrigation season, depending in part on the quantity pumped.
3. Fixed expense, independent of the output of the plant.

The proper design of an irrigation pumping plant in general consists in providing a plant which will deliver most cheaply a given quantity of water in a given time. To design a plant intelligently requires a knowledge of the three component expenses as well as the manner in which they may be varied by altering the details of design.

In general, means should be taken to cut down any component of expense which is likely to become unduly large. To illustrate, if the fuel expense is too high, a more efficient engine should be used, such as a compound instead of a simple, and a condensing instead of noncondensing.

Should the labor cost be unduly high, it may pay to install a larger plant and run it for shorter hours, or to put in a plant which is simpler and does not require a high degree of skill to operate it.

TABLE XXX.
FIRST COST OF PLANTS IN SOUTHERN TEXAS, PER WATER HORSEPOWER.

Gasoline plants			Steam plants		
Water horsepower	Pump plant.	Total	Water horsepower	Pump plant	Total
0.15	\$2300	\$2900	1	\$900	\$1100
0.3	1700	2160	2	675	810
0.4	1300	1800	3	525	680
0.5	1100	1530	4	425	525
0.75	800	1070	5	355	450
1.00	650	870	7.5	240	320
1.5	530	730	10.0	160	220
2.0	450	605	15.0	128	155
3.0	350	500	20.0	110	132
4.0	310	420	25.0	99	117
5.0	275	370	35.0	85	99
10.0	205	265	50.0	75	85
15.0	150	190	65.0	72	80

TABLE XXXI.

FUEL CONSUMPTION PER WATER HORSEPOWER PER HOUR.

Steam plants			Gasoline plants		
Water horsepower	Wood, 0.001 cord	Lb. Coal, 10,000 British thermal units	Water horsepower	Gal.	Cost at 16 cents per gal.
1	42	31	.2	1.3	20.8
2	33	30	.3	1.0	16.0
3	26	29	.4	.84	13.4
4	21	29	.5	.71	11.3
5	18	28	.75	.55	8.8
7.5	13	27	1.0	.43	6.9
10	11½	25	1.5	.34	5.4
15	11	22	2.0	.33	5.3
20	10½	20	3.0	.33	5.3
25	10	17	5.0	.32	5.1
35	9½	14
50	8½	12
75	7	11
100	5	10
150	4	

The average total cost for gasoline plants, of gasoline, labor, and fixed expenses was 22 cents per water horsepower.

TABLE XXXII.

COST OF OPERATION OF STEAM PLANTS PER WATER HORSEPOWER-HOUR.

Water horsepower	Fuel cost, Cents	Labor cost, Cents	Fixed charges, Cents	Total cost, Cents	Corresponding irrigation factors
1	5.7	5.0
2	4.7	3.2	19.1	27.0	9
3	4.0	2.4	13.6	20.0	10
4	3.5	1.8	9.7	15.0	11
5	3.1	1.4	8.0	12.5	12
7.5	2.60	.97	7.0	10.6	9
10	2.30	.75	6.1	9.2	7
15	1.92	.54	4.3	6.6	8
20	1.67	.44	2.9	5.0	10
25	1.46	.42	2.0	3.9	13
35	1.18	.42	1.1	2.6	19
50	.96	.42	1.1	2.5	17
75	.81	.41	1.2	2.4	15
100	.76	.40	1.3	2.4	...
150	.74	.38	1.3	2.4	...

If the fixed expenses are too high, a cheaper type of plant should be installed, or else a smaller plant can be put in and run for longer hours.

The three sources of expense are interdependent, and no system will in general be laid out properly which does not allow and consider their quantitative effect. It should be remembered that high-grade machinery requires in general a more expensive man to operate it than a simpler and less expensive type.

To illustrate the actual results in practical work, tables XXX, XXXI, and XXXII have been compiled from irrigation pumping plants in Southern Texas:

The results are the averages of curves plotted by data from over 100 plants, and represent, it is true, results of various types of plants.

An efficient pumping plant should better the results obtained.

All results are based on the actual water horsepower output of the pump, taking thus no direct account of pump efficiency other than as it affects the cost of plant.

The following are the existing conditions:

Fuel. — Coal is generally of poor quality, varying from 4800 to 10,300 British thermal units per pound, averaging perhaps 8000. Good coal goes up to 14,000.

Cost of coal from \$1 to \$2.25, averaging about \$1.58 per ton.

Wood, usually mesquit, about 3200 pounds per cord. 4500 British thermal units per pound. Cost, 60 cents to \$2.50 per cord; average, \$1.46.

Gasoline, 16 cents per gallon.

Labor, mostly Mexican, very ordinary class.

Wages, 38 cents to \$2.50 per day.

Average, about 65 cents for engineers.

Fixed expenses for pump plant proper — engines, boilers, house and pump — are taken at 20 per cent per year; and for the rest of plant, such as pipes, reservoirs, wells, etc., at 12 per cent.

The *unit-water horsepower-hour* is dependent on what the plant is actually doing, and not on what it might do. Engines, except for the largest plants, are simple, noncondensing.

It is to be noted that fuel costs are low, labor is very low, but the fixed expenses are unduly high. This is due to having too low an irrigation factor. In other words, the plants are too large for the areas watered, and it would pay to take means to

avoid making so large a first investment with its consequent fixed charges. With gasoline plants of small capacity no attendance is needed. In spite of the high cost of gasoline, small plants of this nature are more economical to run than steam plants, owing partly to the fact that they do not require constant watching.

The effect of the irrigation factor on the cost per unit quantity of water may be seen in the following case :

Supposing a plant delivers 2 cu. ft. per sec. at a total cost per 24-hour day of \$8 for labor and fuel, that the fixed expenses are

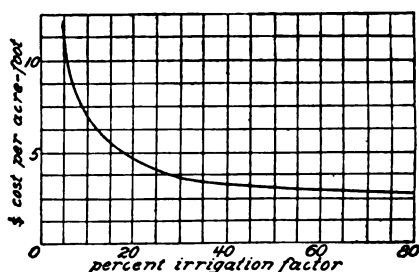

Fig. 26.

\$2 per day, Table XXXIII and curve in Fig. 26 show the cost of delivering water per acre-foot for various irrigation factors.

Cost of water per acre-foot = \$2.02 for fuel and labor.

TABLE XXXIII.

Irrigation factor	Fixed expense per acre-ft.	Total cost per acre-ft.
5	\$10.10	\$12.12
10	5.05	7.07
15	3.37	5.59
20	2.53	4.55
25	2.02	4.04
30	1.64	3.71
40	1.27	3.29
50	1.01	3.03
75	.67	2.69
100	.50	2.52

Figs. 27 and 28 show tests of two of the New Orleans drainage pumps, for handling the city rain water. The units are of the

direct-connected vertical type, and consist of a centrifugal pump, driven by a synchronous motor. The curves are all plotted with rate of discharge in cubic feet per second as abscissæ.

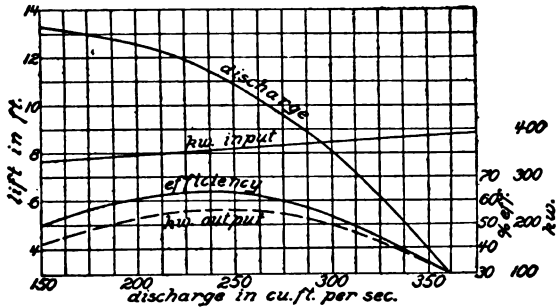

Fig. 27. Performance of New Orleans Drainage Pumping Plants at Constant Speed.

The discharge curve shows relation between flow and lift. The kilowatt-input curve shows the relation between the flow and the kilowatts-input to the motor. The kilowatt-output curve shows

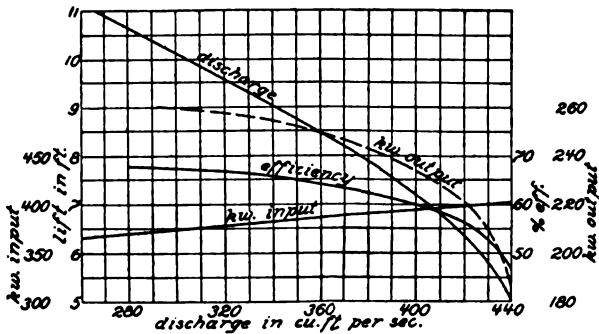

Fig. 28. Performance of New Orleans Drainage Pumping Plants at Constant Speed.

the relation between the actual effective kilowatts output of the plant in lifting water, and the flow. The efficiency curve shows the relation between the ratio of power output of water and power input to motor, and the flow. In other words, it shows the total efficiency of the plant.

To illustrate the method of calculation of irrigation pumping plants, assume the following data for a plant for 300 acres:

1. Depth per irrigation at the land, 3 inches.
2. Frequency of irrigation, once every 10 days.
3. Irrigations per year (no rain), 9.
4. Rainfall during irrigation season, 3 inches.
5. Pumping plant to operate 12 hours per day.
6. Loss in ditches, 20 per cent of supply.
7. Water raised by pumping, 30 feet.
8. 12-inch suction and discharge.
9. 200 feet 12-inch pipe in both.
10. Centrifugal pump, 60 per cent efficiency.

- Required
- (a) Capacity pump gallons per minute.
 - (b) Depth of water per season.
 - (c) Depth of irrigation water to be pumped per season.
 - (d) Irrigation factor.
 - (e) Total head.
 - (f) Horsepower to drive pump.
 - (g) Horsepower hours per acre per year.

(a) *Capacity of pump.* — By Table II, required flow = 5.7 gal. per min. Since the pump operates 12 hours per day, pump capacity = $\frac{300 \times 5.7 \times 2}{0.8} = 4280$ gal. per min.

(b) *Depth of water per season* $3 \times 9 = 27$ inches.

Subtracting 3 inches rainfall leaves 24 inches irrigation to be applied per year.

(c) *Depth of irrigation water to be pumped per season.*

The pump supply = $\frac{24}{0.8} = 30$ inches, allowing for ditch loss.

(d) *Irrigation factor* = $\frac{80}{365 \times 2} = 11$ per cent.

(e) *Flow of 4280 gal. per min.* — by Table XXVII.

Makes loss of $200 \times 45 \div 1000 =$	9.0 feet in pipe.
Loss at entrance	1.2 “
Loss at discharge	<u>2.3 “</u>
Total	12.5 “
Static head	<u>30.0 “</u>
Total head	42.5 “

(f) *Power to drive the pump.*

$$42.5 \times 4280 \text{ gal. per min.} = 181,900.$$

Hence at 60 per cent efficiency by Table XXVI the power required = 77 horsepower.

$$(g) \text{ Horsepower-hours output of engine per acre per year} = \frac{30}{12} \times 1.37 \times \frac{10}{6} \times 42.5 = 242.$$

If a steam plant be installed with simple noncondensing engine it will cost approximately \$4800.

Figuring 7 per cent interest and taxes,

11 per cent depreciation, repairs, and renewals,

2 per cent operating expense,

$$\overline{20} \text{ per cent fixed expenses} = \$960 \text{ per year, or } \$3.20 \text{ per acre.}$$

If one man operates the plant for the season of 90 days, receiving \$3 per day, the operating expense is \$270, or 90 cents per acre per year.

If the fuel be coal of 12,000 British thermal units per pound, say the plant will require 4 pounds per horsepower-hour. If this costs \$6.00 per short ton, the cost per horsepower-hour = 1.2 cents, or \$2.90 per acre per year.

Summarizing: Fuel cost	\$2.90 per acre per year.
Labor cost.	90 per acre per year.
Fixed expenses.	<u>3.20 per acre per year.</u>
Total	<u>7.00 per acre per year.</u>

CHAPTER X.

IRRIGATION NEAR BAKERSFIELD.

To illustrate the actual results of a large irrigation pumping system, the following account is given, of irrigation near Bakersfield.

One of the largest irrigated districts of California is in the vicinity of the city of Bakersfield, which is situated about forty miles north of the southern end of the San Joaquin Valley, where the Coast Range and Sierra Nevada mountains unite. The rainfall in the surrounding country is perhaps lower than in any other habitable portion of the state, being on an average about 4 inches. The rain nearly all falls in the winter and early spring, the remainder of the year being dry. Owing to the lack of moisture, much of the surrounding country for the greater portion of the time is barren of vegetation, with the exception of sage brush. The Kern River, which emerges from the mountains about sixteen miles from Bakersfield, is the only watercourse of importance in the country for many miles. After the river leaves the mountains it flows for several miles through the foothills, finally entering the valley about four miles above Bakersfield (see Fig. 29). The river follows the main slope of the country, which is to the west, and somewhat to the north, into Buena Vista Lake, an artificial reservoir which has been constructed at the west side of the valley by building several miles of levee to retain the waters. The natural discharge of this lake is towards the north, to Tulare Lake. The bed of the river, like most of the surrounding country, is of a sandy nature.

The flow of the river is usually greatest in May and June, when it frequently reaches 4000 cubic feet per second part of the time, and it has been known to discharge 11,000 cubic feet per second at the time of a high flood. The water is diverted by several large canals, the largest of which is the Calloway, which is about 35 miles long, and has a capacity of about 900 cubic feet per second.

This canal is 80 feet wide on the base, 120 feet on top, and 5 feet deep.

The water which is not utilized in irrigation is stored in Buena Vista Lake, which is about six miles square, with a storage depth of 10 feet. The cost of the reservoir was \$150,000 (Schuyler), and the capacity 170,000 acre-feet or 88 cents per acre-foot, an exceedingly cheap cost for reservoir construction. From the reservoir large areas of land are irrigated. In good years there is an abundance of water in the reservoir, but in times of protracted drought it is entirely without water, and the bottom is absolutely dry. The Kern County Land Company, and Miller & Lux, practically control the entire water supply, as well as the land, in this part of the country. These two companies are primarily engaged in the cattle business, and one of the main objects of the agricultural development is to furnish food for the cattle. Although other branches of agriculture have been developed, the greatest part of the irrigated land is planted in alfalfa.

The various canals owned or controlled by the Kern County Land Company are all separate canal companies, each of which has its own organization; but they are all under a common management, The Kern River Canal Company, which controls the division of water between the different canals, as well as the distribution to the various owners. When water is scarce, instead of each canal receiving its proportion of water, it is all turned into a few canals at a time, and pro-rated according to the water rights on those canals. When the farmers on these canals have finished irrigating, the water is turned into other canals, and in this manner the central management effects as fair a distribution of water as is possible, and avoids undue seepage losses by having the water in as small a length of canal as possible.

In dry seasons the river water is exceedingly low, and consequently it was desirable, if possible, to install an auxiliary system to obtain water when the river supply ran low. The only available supply was the underground water. There were excellent indications of the possibility of obtaining a large supply of water from pumped wells. The ground water level over much of the country near Bakersfield stood from 3 to 25 feet below the surface of the ground, the distance depending

on the location and the season. Cheap electric energy was available for the operation of pumps, as the Power Development Company had its lines already in Bakersfield. This company obtained its energy from a hydro-electric plant situated at the place where the Kern River emerges from the mountains. A fall of 220 feet in the river is obtained by conducting the water through a tunnel 1.75 miles long. Three-phase electric energy is transmitted 17 miles to Bakersfield, under 10,000 volts pressure.

The first pumping station which was installed consisted of a horizontal centrifugal pump belted to an induction motor. The pump was connected to several wells, and was set some distance below the ground in order to be as near the water level as possible. Owing to the variation in the level of the ground water, there were objections to this method of operation, since, if the pump were set too low, the ground water in some seasons might rise until it covered the pulley. This would necessitate pumping out the pit in which the pump was placed, by another pump, in order to lower the water sufficiently to put the belt on. After the pump once started, it would, of course, keep the pit dry, and then there would be no danger unless it should stop while the attendant was absent. If the pump were set up high enough to be out of danger from the rising ground water, it would be so high that it would exhaust the wells, and suck air when the ground water went down in dry seasons. This was due to the fact that it was desirable to obtain as much water as possible from the stations, and hence to exhaust the wells for several feet in depth. In order to overcome the difficulty of exhausting the wells beyond the suction limit, and sucking air, which would make the pump lose its vacuum and stop pumping, a vertical pump was installed. The pump was set at the bottom of a vertical frame, and was driven from a horizontal motor by a quarter-turn belt. Finally, to avoid the belt losses, a vertical motor was used, direct-connected to the pump.

The following is a description of the method of installation, and the apparatus used in the latest stations. The frame is 20 feet high, and consists of four angle irons thoroughly braced by lighter angles and united at the top to a cast-iron ring on which the motor is fastened. The top ring is provided with adjusting screws for lining up the motor. The pump, which is a

No. 8 centrifugal, has two inlet openings diametrically opposite, and on the upper side of the runner. The pump shaft after passing through a stuffing box and an upper bearing, which is bolted to the pump casting, is connected by a coupling to the intermediate shaft, which in turn is connected to the motor shaft by a similar coupling, which allows of a longitudinal adjustment of the pump shaft for the purpose of balancing. There is about 1.5 inches end play in the pump runner, which may be made use of in balancing the end thrust of the pump, which is largely dependent on the position of the runner in the shell. This end thrust may be very large in some pumps, and it is highly desirable that it be properly balanced, as otherwise it is likely to cause serious trouble. The intermediate shaft runs in one or two adjustable bearings (the number depending on the length of the shaft). These bearings are fastened to the angle iron frame. Below each motor bearing, and fastened to the shaft, is a cylindrical brass receptacle, which catches the oil which drips from the bearings. A stationary bent tube inserted in this receptacle catches the oil due to its high speed, and forces it up the tube, returning it to the top of the bearing. Thus the oil is kept in constant circulation.

This oiling device was not satisfactory, as it threw oil all over the motor from the fine spray which formed. It was finally much improved by a change of design which did away with all trouble, and in addition passed the oil through a filter before entering the bearings. The entire weight of the rotor, and of the pump runner, at the start was taken in the top motor bearing, and the bottom bearing of the motor limited the play due to up thrust of the pump in case it was sufficient to raise the rotor and runner both. The upper bearing of the motor was unable to stand running with the weight of the motor armature alone, as it would have burnt up under these conditions, so it was necessary to rely on the end thrust from the pump relieving, in part at least, this pressure. The result in practice was satisfactory, however, and gave little trouble. The suction entrance on top of the runner served to exert a strong upward force, and by proper adjustment the pump could be made to balance perfectly and to lift exactly the weight of the revolving parts. Still, it would in general be desirable to have bearings better able to stand a greater end thrust without danger.

The usual method adopted before establishing a station, was first to bore a 6-inch well to determine the nature of the strata, and to see whether there was a probability of getting a good well. If the indications were poor, the site was abandoned. Twenty feet of good water-bearing sand, or sand and gravel, were considered a good indication for a well.

If the indications were good, a 13-inch well was next put down and tested by pumping it with a centrifugal pump driven by a steam engine. If the well delivered a flow of 1.5 to 2 cubic feet per second, while the water was drawn down 20 to 25 feet in the well, the test was considered good, and three additional 13-inch wells were put down. These wells were all in a line, and about 8 to 12 feet apart. Riveted, galvanized iron well-casing was used. The joints opposite the water strata were perforated before being put down, by narrow slits about an inch long, as a better job could be made than by perforating in place. A steel shoe was fastened to the end of the casing, which was forced down by a weighted lever, while the material was removed from the inside by a sand pump. It was desirable not to perforate the casing too high up, as the surface water, carrying considerable air and falling into the well water when the well was exhausted to a considerable depth, was liable to drag air into the suction pipe and make the pump lose its vacuum.

In order to serve as an adjunct to the strainer, and to keep sand from flowing too freely into the well, a pipe was driven into the ground next to the well casing as it was being put down, and the top of this pipe kept covered with gravel, which followed the well casing down and formed a layer over the outside of it.

When for any reason it was impossible to land the casing in clay or rock, the bottom of the well was filled with loose rock to keep the sand from coming up the well. The wells varied in depth from 60 to 110 feet.

After the wells were completed, a pit was dug around them to a maximum depth of about 20 feet. In the latest stations the pits were sunk a few feet below the existing ground water level, at the time they were put in. A portable, direct-connected 30-horsepower motor and a No. 8 centrifugal pump were used to keep the water out of the pits during the installation of the

station. The pump, which had its suction pipe down one of the wells, was kept running continuously during the construction of the pit.

The four wells for each station were all in line, and were arranged so that the vertical pump was in the center, with two wells on either side.

The pit is lined with redwood, the lower boarding being 2 by 12, and the upper boarding, 1 by 12. The flooring, which consists of a double layer of 1 by 12, is laid on mud sills, and arranged so as to break joints. The joints on the sides of the pit are covered with 1 by 4 battens to make them tight and to keep the sand from flowing into the pit. Inside the pit, 4 by 6 vertical stringers are set 3 feet apart, braced by 4 by 6 horizontal timbers every 6 feet. The pits are made 6 feet wide, except in the center, where they are 8 feet wide, to allow for the pump and frame. The timber lining of the pit was carried up about two feet above the ground, and the pit was covered by a roofing of shakes.

In the center of the building where the motor stands, a house is built about 12 feet in height above the ground, provided with a ventilator in the roof and also in the side. The flooring of this house is level with the top of the pit, and the top of the frame on which the motor stands is slightly above the floor level. Thus the motor is in a position where, even should the pit fill with water, it will not be damaged. Entrance to the pit is provided by a door in the roof, and to the motor house by a side door. A layer of hay is thrown in next to the boarding of the pit when backfilling the outside of the pit, in order to prevent the sand from flowing in through the cracks in the boards. The casing of the wells is cut off just above the pit floor level, and is hammered down so as to make a flush joint with the floor. The piping is all composed of galvanized iron riveted and soldered.

Vertical 6-inch pipes about 40 feet long are inserted in each well, and are provided with flanged couplings to connect to horizontal suction pipes, which run to the pump.

The discharge pipe is 10 to 12 inches in diameter and runs into a wooden box 3 feet wide, at the end of which is an uncontracted weir. These weirs are provided with glass gauge tubes connected by pipe fittings to the water on the inside. A wooden strip is nailed on the outside of the weir at the level of the crest, which

is composed of a strip of galvanized iron. The head on the weir is measured by a foot rule, the end of which is placed on this strip, the head being told by the level in the gauge glass.

In the enlarged pit, where the pump frame stands, are fastened square frames of 6×6 timber surrounding the pump frame. These are placed 6 feet apart, and are used to steady the pump frame by the use of bolts between the timber frame and the corner angle irons of the pump frame.

About 60 feet from the pump house is a transformer house where the transformer, motor starter, switches and fuses are located. These houses have been separated, so that, in event of a fire, the plant would not be a total loss. Energy is furnished to the transformer houses at 10,000 volts, 3 phase. The lines enter the transformer house passing through a 10,000-volt fused-pole switch, operated by a lever inside the transformer house. Three lightning arresters are connected to the 10,000-volt wires, which then run to two 10,000-, to 550-volt transformers.

Two types of transformers are used — 15-kilowatt air-cooled being in some stations, and 25-kilowatt oil-cooled in others. The three 550-volt wires pass first through asbestos-covered fuses, the fuse blocks being mounted with asbestos behind them so as to minimize danger from fire, and then through a knife switch, and the auto starter for the motor, from which they run to the motor. The wire joining the two transformers on the 550-volt side is connected to a static arrester, the other side of which is grounded.

The lighting circuit is taken from a 30-volt tap on the transformer secondary, the tap being next to the wire connected to the arrester to minimize danger from shock. Thirty- and 40-horsepower, 3-phase, 550-volt motors are used for the pumps, which are No. 8, and run at 900 revolutions per minute, delivering between 3 and 5 cubic feet per second, depending on the lift, the usual head being 40 feet.

As the stations were to be operated with little attendance, it was necessary to make everything about them as safe as possible from the effect of possible accident. With this in view, each station was provided with an automatic cut-out, to cut out the motor in case the power went off. For this purpose a heavy weight, sliding in ways, was hooked to the switch handle.

This weight was released by a trigger, and thus required very little power to make it open the switch. Several devices were used to operate the trigger, the particular form depending on the conditions of the case. In a transmission system there is always the liability of a momentary short circuit, caused by a discharge of the lightning arresters, or by some other cause, making the voltage drop for only a few instants. In such an event it is not desirable for the cut-out device to operate, and it must be designed with that in view. The form most commonly used consisted of a vertical tank in which was a float provided with a vertical stem engaging the trigger. This tank received its pressure from a point near the pump discharge, the water standing at a level above the crest of the weir equal to the head on the weir plus the friction head in the pipe. If the pump stopped, the float would gradually sink until it tripped the weight, but a temporary slowing down would not affect it.

Another device consisted of a curved vane in the discharge pipe, supported by pins, one of which extended through a stuffing box and operated the trip lever through a bell-crank lever. When water was flowing it kept the vane along the pipe where it offered little additional frictional resistance, but when it ceased to flow, the weight of the vane tripped the switch-opening weight.

Time element electric devices have also been used. These consisted of a laminated electromagnet, the armature of which was kept closed by 30-volt alternating current. In one form of device there was a glycerine dashpot connected to the armature, there being a small hole in the piston to allow of slow motion. If the power went off and came on again before the piston sank too far, the armature would be reattracted before the switch had opened. In another form the retarding element consisted of a small fan blade connected to the armature by clockwork.

In general, the first two forms are more desirable, where they can be used, since if for any reason the pump loses its priming, they will cut out the motors.

With regard to piping leading to the float boxes, for the first form, it is advisable to use in general galvanized pipe, and not to use too small a pipe, on account of danger of the pipe rusting

up and stopping. This is important, particularly where the water is alkaline.

As there was in some cases a considerable volume of piping to prime before starting the pump, priming by hand was too slow, so air pumps were installed in the pits, belt-driven from the motor shaft. When the pump was primed the belt was taken off. This saved considerable time in starting the stations, and pumps which took half an hour to prime by hand could be primed in a few minutes in this manner. Check valves and sometimes gate valves were placed just above the discharge outlet of the pump, to close the pipe for priming. In some stations when they had not been run for considerable time, the water carried a large amount of entrained air, which, if the pump were run with the discharge open, would be liable to make the pump lose its priming. For these stations the gate valves were a decided aid in operation, as they could be used to throttle the discharge, as long as there was any trouble of this nature.

Fig. 29 is a map of the pump stations of the Kern County Land Company. There are, altogether, 27 well-pumping stations scattered over a considerable area denoted by small squares and numbers along the lines of the Power Development Company. This was divided into three sections, and one pump man assigned to each section. These three pump men attended, alone, to the operation of all the plants, visiting each station in operation twice a day. Each pump man was provided with a horse and cart. In addition the operation of the plants required part of the time of an inspector, who had charge of all repairs and installation work, and the services of his assistants. The pump men, who were not skilled mechanics, were expected to attend to merely the operation of the stations and to report any repairs needed. When in operation the stations ran continuously day and night, and were shut down only a very small proportion of the time. Thus it will appear that the cost of operation was reduced to a minimum — quite a striking contrast to the method of operation adopted in some pump stations, where three men working 8-hour shifts are employed every day to watch one 30-horse power motor and pump operate.

It may occasion doubt in the minds of many whether such a method of operating is wise, and whether it is not taking undue

chances of loss from accident from no attendant being at hand. The experience of the writer is quite to the contrary. In fact, the total loss from accidents which could have been avoided by

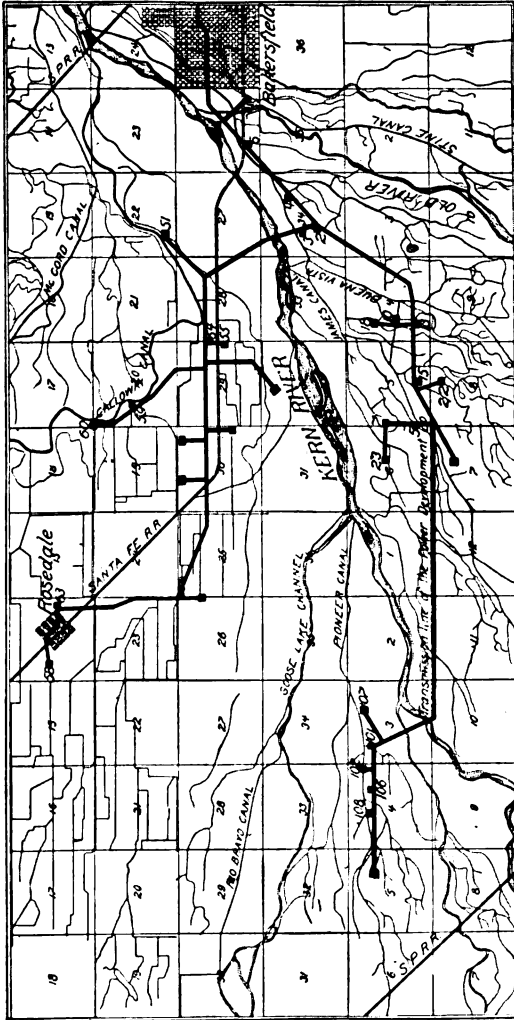

Fig. 29. Map of the Bakersfield District.

constant attention, would not exceed a few hundred dollars during the writer's connection of two years with the company.

No serious accident occurred during that time, the only damage being the burning out of an occasional bearing. The secret of success in such a matter consists in keeping the plant always in the best order, occasional overhauling, and constant watchfulness.

The pumps discharged into the same canals used by the gravity system, and consequently there is no direct means of obtaining a record of the value of the irrigation. Further, as they were used only to supplement the river water, the duration of their operation during the year was a variable. Had they been used as the sole source of water supply, they would have run nearly continuously throughout the year, in a climate like that of Bakersfield with its very small rainfall. Of the river water, one-third of the total water supply is lost in the canals. It takes, on an average, 1 acre-foot of water supplied to the canals, for the irrigation of 1 acre of land per irrigation. The pumped water has far shorter distances to travel than river water. Allowing for the effect of a decreased quantity, and greater relative seepage losses, it will be conservative to say that it takes 1 acre-foot of pumped water to irrigate an acre of land. Land is irrigated once per cutting for alfalfa, and yields an average crop of one ton per acre. Hence 1 acre-foot of pumped water is needed per ton of hay, and 4 acre-feet per acre are required, per year, as four crops are grown in a year.

The average output of the pump stations was 3.3 cubic feet per second. This average was cut down to this value by some poor stations where the wells were weak. The average motor horsepower per station was 33. Energy was bought according to the horsepower of the motor installed, and with no reference to the load, the price paid being five-eighths cent per horsepower-hour. Hence the cost of energy per 10 horsepower-day was $\frac{5}{8} \times \frac{240}{100} = \1.50 , which was the cost per second foot of water per day. Hence the cost per acre-foot was 75.7 cents for energy alone, or double the cost charged for gravity water by the canals. The remaining expenses, including wages, repairs, and all fixed expenses, were practically constant, and were independent of the hours of operation of the plant. In estimating the fixed expenses, 7 per cent is assumed for interest and taxes, 6 per cent for depreciation. The total cost of the

27 stations, including the cost of abandoned stations, was \$92,000, nearly 4 per cent of which was for abandoned stations.

The total annual expenses were as follows:

Fixed expenses, 13 per cent of \$92,000	\$11,960	per year.
Cost of attendance	2,477	" "
Cost of maintenance	3,035	" "
Cost of repairs and renewals	3,419	" "
Total annual expenses	<u>\$20,891</u>	" "

The actual expense for attendance was for the 27 plants, \$2477 per year, or \$91.75 per station, or 25 cents per station per day. This included wages and board of the attendants, feed for their horses, and repairs on their wagons. This is an exceptionally low figure, and it is very doubtful if any stations of equal capacity ever came anywhere within several hundred per cent of these figures.

The charges for maintenance included the time of the pump inspector and his two helpers in ordinary overhauling of the stations, and also all supplies for operation, such as oil waste, etc. The charge for repairs included a \$1700 charge for the reconstruction of one of the first experimental stations installed. The peculiar conditions encountered made this reconstruction a very expensive piece of work, and one which was little likely to recur. However, work of reconstruction as well as the danger of accident must always be considered in fixing costs. Included under repairs and renewals were certain improvements which more properly belonged under installation. Taking this into consideration, the charge of 6 per cent for depreciation is a liberal value, as the repairs and renewals are nearly 4 per cent. A very large part of the charges for maintenance and repairs consisted in team hire, and time lost in getting around the country, owing to the widely scattered stations.

The total charge of \$8931 per year which actually had to be paid out, was only 91 cents per day per plant. If the plants ran continuously they would have raised 177 acre-feet per day, or $177 \times 365 = 64,500$ acre-feet per year, at a cost of 33.2 cents per acre-foot for fixed charges; or a total cost of $75.7 + 33.2 = \$1.09$ per acre-foot. During the last part of the year in question, the pumps ran only 34 per cent of the total time, making the expense of all charges but power, per acre-foot, 98 cents, and the

total cost \$1.74 per acre-foot, and hence per ton of hay. This was an exceptionally low irrigation factor, and was due to the fact that owing to accidents the Power Development Company had been unable to furnish energy for the operation of the pumps.

During the first six months of the year when energy was obtainable, the pumps ran about 90 per cent of the time, though no record was kept of the same, as at that time energy was paid for on a flat rate of \$30 per horsepower-year for the first 100 horsepower, \$25 per horsepower-year for the second, and \$20 per year for all additional horsepower. Under those conditions the annual cost of energy for $33 \times 27 = 991$ horsepower was \$19,320, which is 29.9 cents per acre-foot, assuming 100 per cent irrigation factor, or 33.2 cents, assuming 90 per cent irrigation factor. Adding to this latter figure the corresponding rate of 37 cents for fixed and operating charges, gives a total cost per acre-foot of 70 cents.

Hence, owing to change of rates and conditions in the same year, the cost of water went from 70 cents to \$1.74 per acre-foot. With 90 per cent irrigation factor and five-eighths cent per horsepower-hour, the cost would be \$1.13 per acre-foot. The value of a ton of hay in the field is fully \$4. Under the system of charging by the rated motor horsepower, a far more economical showing could be made by installing much smaller motors in the stations where the wells were weak. As the pumps gave an efficiency of 60 per cent, they were capable of lifting on an average lift of 40 feet, 4.4 cubic feet per second; the 30-horsepower motors, 4 cubic feet per second, and the 40-horsepower motors, 5.3 cubic feet per second. The actual output of plants went from 1.6 to 5.7 cubic feet per second, and the lifts from 30 to 50 feet. The efficiency of a pump in practice, when operating under a high vacuum, will usually be less when pumping from a well than when pumping from a pond, due to the entrained air. Mr. L. A. Hicks was the first engineer in charge of the installation of the pumping plants, and was succeeded later by the author.

CHAPTER XI.

METHODS OF CHARGING FOR IRRIGATION WATER.

THERE are, in general, three systems of charging for irrigation water, at present in use:

1. Where no particular limitation is placed on the water, contracts simply stating that the farmer will be provided with sufficient water to irrigate his land;
2. where he will be provided with a stated flow for a stated length of time, distributed at stated periods at a stated annual rate;
3. where the charge for water is directly proportional to the amount of water used.

None of these systems is in general altogether equitable, since it does not proportion the expense for water to the cost of delivering the same. The best system of charges should fulfill three conditions: 1. It should proportion the charges to the expense of delivery. 2. It should induce economy on the part of irrigators. 3. It should be simple.

Consideration of No. 1 requires an analysis of the elements of the cost of furnishing water. Take, for example, the case of an irrigation company furnishing pumped water to its customers. For the company to be in position to supply water for irrigation, it must first provide a pumping station, ditches, gates, etc., all of which are in proportion to the sum of the maximum rates of demand of the water supplied to customers. Before starting to deliver water to consumers the plant must be operated to a sufficient point to supply losses in the canals. Up to that point of operation the individual guaranteed rate of supply is a measure according to which the expenses should be divided. Additional expense of operation of the plant beyond this point will consist mainly of fuel and labor, and will be proportional to the actual quantity of water used; hence all expenses beyond this point of operation should be divided in proportion to the actual quantity of water consumed. In other words, an equitable policy, to fulfill condition No. 1, would consist of charging each consumer of water a fixed rate with a guaranty to supply him

with such a flow for a given length of time every so many days, and in addition should charge a rate directly proportional to the actual amount of water used. Such a system would tend to promote economy in the use of water, as it is directly to the financial advantage of the irrigators to practice it. Moreover, it is a fair basis of division of the charges, and it is only right that the farmer who is economical should not pay for the extravagance of his neighbor. In some places, usually where no limitation is placed on the irrigation water, the payment for the same consists of a certain percentage of the crop. This method of charging has the advantage of attracting people with small capital. However, it sometimes occasions disputes, and is liable to give rise to a suspicion that the farmer has not reported the full amount of his crop. Of course the manager of an irrigation company has to consider, in addition to charging for furnishing water on an equitable basis, the idea of presenting an attractive prospect in order to settle the country and to obtain customers. This may be used as an argument in favor of the percentage of the crop basis of charging, on the ground that this system would attract those who would not otherwise enter into the undertaking. A careful consideration of the actual cost to an irrigation company for the delivery of water indicates that the charges for same should be divided among customers in accordance with a method embracing the three following principles:

1. Expense which should be borne equally by the consumers.
2. Charges pro-rated according to the maximum required flow.
3. Charges proportional to the volume of water actually used.

Charges of the first nature may be considered to include general expenses of the company as well as the expense of *zanjeros*.* Under the second heading may be classed the charges which are independent of the water actually delivered; in other words, charges of this nature should be for the cost to the ditch company of being in a position to deliver water at a certain rate.

Charges of the third kind are dependent upon the cost to the company of actually delivering a given quantity of water.

In a pumping plant, for example, the capacity of the station would have to be proportioned to the maximum rate of demand for water; hence all expenses for operating the plant to a sufficient point to supply the seepage losses in ditches and for interest and

* *Zanjero* is the Mexican name for ditch tender.

depreciation on the plant, should be pro-rated according to the maximum rates of demand of the various customers. The annual value of the water right, if the same has any value, should also be pro-rated in the same manner, as well as the interest on and cost of maintenance of ditches, gates, etc. The additional cost of delivery of water over what would be necessary to keep the ditches full and in repair, should be borne by the customers in direct proportion to the quantities of water actually used. This would mean, in other words, that a customer of the company would pay the company a certain fixed sum for the privilege of obtaining water, and in addition thereto a sum varying directly with the rate of use of water which the company guarantees to furnish. In event of any shortage of water, this latter rate would not be the same, but the water would be delivered among the various customers in proportion to the rates of delivery for which they pay. Besides these two charges, the customer would pay a rate proportional to the actual volume of water delivered to him. In fixing the rate of charge at a given rated delivery, a reasonable amount of time should be taken. For example, provided the consumer uses a flow of 3 cubic feet per second for one day a week, the flow for which he should be charged would be three-sevenths of 1 cubic foot per second. In other words, the flow should be reduced to the basis of a maximum continuous flow, and should not be considered as a maximum absolute flow. A contract for water would then state that the consumer was entitled to a certain specified flow delivered for a specified number of hours once every so many days, for which he would pay a specified rate per month, whether or not use was made of this *quantity* of water; and in addition would pay a fixed rate per acre-foot of water delivered. This would make it to the advantage of the consumer to apply for as small a flow as possible and to use the water as economically as possible, both of which are desirable features in the practice of irrigation. If during the course of the year the consumer found he would need more water than the flow for which he had contracted, if this water were available he could obtain it by paying for it at the fixed rate per acre-foot.

This method of charging for water might lead to a tendency to reduce the flow applied for to a quantity too small for the needs of the land, in order to reduce the charges under the

second head, consumers relying upon being able to obtain surplus water at the price charged per acre-foot. However, by so doing they would render themselves liable to suffering from possible shortage in supply, and steps could easily be taken by the company to prevent this becoming an abuse.

In considering the proportions of the constituent parts of these three charges, three distinct cases may be taken up: 1. Gravity distribution without storage. 2. Storage system of distribution. 3. Pumping distribution.

In the gravity system the largest charge would be for the guaranteed flow of water, the total amount of water used making little difference in the cost to the company.

In case No. 2, assuming an expensive reservoir system from which the water is mainly supplied by storage, the charge for the quantity of water actually used becomes comparatively great, since the interest on the investment in the reservoir, repairs, and depreciation of the same are chargeable to the value of an acre-foot of water.

In case No. 3, the additional cost of fuel and labor contributes largely to charge No. 3. Let:

A = Annual interest, depreciation, repairs and taxes on reservoir.

B = Total annual value of water right.

C = Annual value of water lost in distributing canals.

D = Labor and interest on, and repairs, and depreciation of main and distributing canals.

E = Annual cost of *zanjeros*.

F = General expenses.

G = Interest and depreciation on power house, head works, labor, operating expenses, and cost of fuel sufficient to supply seepage losses of canals.

H = Additional annual expenses of power house required for operation of plant at capacity demanded.

N = Number of customers.

P = Maximum rate of consumption of water.

p = Individual rate of consumption.

Q = Acre-feet stored less evaporation and seepage from reservoir = total acre-feet of reservoir output, or = output of pump station.

q = Acre-feet sold to individuals.

X = Acre-feet lost in distributing canals.

Assuming case No. 2, where practically all the water is stored and must be taken from a reservoir, the following three charges should be made:

$\frac{E + F}{N}$ should be charged alike to each applicant for water,
as charge No. 1.

$\left(\frac{B + C + D}{P}\right)p$ = charge No. 2, where $C = \frac{AX}{Q}$.

$\frac{Aq}{Q - X}$ = charge No. 3.

Suppose the water for irrigation is supplied direct to the land from a pumping station, then charge No. 1 would be the same as in the last case.

$\left(\frac{B + D + G}{P}\right)p$ = charge No. 2, charge C being included
in G .

$\frac{Hq}{Q - X}$ = charge No. 3.

These cases will serve to illustrate the general method suggested, — which is similar to a method of charging for electric energy, proposed by Mr. A. M. Hunt, — and form a basis from which equitable charges for water may be made. In proportioning the charge for the water itself, the assumption has been made that the value of the water *per se* lay in the broader right to utilize a given flow of water, and not in the intrinsic value of the water itself. This is true on the assumption that water not so utilized would have no market value. If, on the other hand, however, such water has a market value *per se*, then the real value of the water becomes of two kinds: (1) the value of the water right itself, and (2) the intrinsic value of the water. In this event the latter value should be added to the charge for water. Take the condition of a gravity plant without storage which

has sold water rights up to the limit of its capacity, providing at certain periods of the year its full capacity will not be required, due to wet weather or other causes, no material saving will result to the company from this cause, nor can the water not so used be disposed of. In that event it is not just that anything but a small charge should be made for the same. Broadly speaking, in a gravity system the equitable system of charging would tend more toward a flat-rate system than toward a meter system. The system proposed, however, is one which combines the principles of both these systems.

In countries where water is scarce and the supply not equal to the demand for irrigation, water may justly be assumed to have a high intrinsic value in addition to the value of the right to use a certain flow. This matter should be taken into consideration in fixing a rate per cubic foot per second. For a rate to be fair to a company investing capital in an irrigation plant, an income should be assured to the company in wet years as well as in dry years, and any increased expense for actual amount of water delivered in addition to the expense necessary to be in position to deliver a given flow should also be charged to the consumer as charge No. 3.

CHAPTER XII.

ECONOMIC LIMIT OF IRRIGATION.

THE greater part of the present water supply of irrigation plants consists of the water diverted by gravity from flowing streams, conveyed by ditches to the land. Though in some cases the development cost of gravity water so obtained is high, still in the majority of instances the cost per unit volume of water diverted is small, and the cost of irrigation of this type is particularly low in comparison with the greatly increased productivity of the land. In the arid region, much of the land is of little or no value without water, while the soil and climate are such that irrigation is capable of producing plentiful crops and proving of value far greater than the cost of irrigation, where the development is not expensive.

According to Elwood Mead: "If every drop of water which falls on the mountain summits could be utilized, it is not likely that 10 per cent of the total area of the arid West could be irrigated, and it is certain because of physical obstacles that it will never be possible to get water on even this small percentage." The available proportion of the rainfall is greatly limited, the water being disposed of in four manners: Evaporation from the surface of the ground, transpiration losses, underground waters, and surface run-off. Much of the water is lost by evaporation before it has an opportunity to seep into the ground. The preservation of the forests helps greatly to diminish this loss, protecting the land from the rays of the sun, and allowing the water time to sink into the ground, to join the underground waters, which flow through the subterranean drainage system of the country. The underground supply, which is the source of supply of all springs and wells, both pumped and artesian, is hence by no means unlimited in quantity. It will often be found in regions where there has been very extensive well-development, that the static level of the water in the wells has greatly lowered; wells which formerly gave a strong artesian

flow have weakened in flow or have ceased to flow, and must be pumped, while from pumped wells the water must be lifted from greater depths.

It is evident that the actual water supply which can be made available for irrigation in the arid region is far less than the needs of the land which is capable of being irrigated. As much of this land is valueless without irrigation, there will ultimately be use for all the available water supply, provided the cost of development is not too great, and it is this cost alone which will limit the use of water. Evidently the present cost of irrigation water will by no means determine the ultimate irrigation development.

Where the cost of irrigation is but a small percentage of the benefits derived therefrom, far higher prices can be profitably paid therefor. Water, *per se*, has an intrinsic value, where the demand exceeds the supply, quite apart from the cost of development, and the land to which the water right attaches will on that account increase in value up to the point where the net value of irrigation will yield a fair profit on the increased investment. Hence it is evident that irrigation development will tend to increase until the costs of irrigation will allow only a reasonable profit from its use. This will not in general be before, at least in many places, the entire low-water supply is utilized, and much of the water which now runs to waste is stored in reservoirs. After the natural flow of the streams is all utilized during low water, further development must come either from storing the surplus water thereof, at periods when it would otherwise run to waste, or by developing the underground supply, usually by the use of wells. The development of water supply by these two methods is quite extensive, and although most wells must be pumped, still improvements in pumping machinery and the increased use of electric transmission circuits covering the country with a network of lines are reducing greatly the cost of pumping water.

A study of present costs and values of irrigation brings out very forcibly the fact that a very extended use may be expected of reservoirs in the United States, and that in many cases water may be stored at costs well within the present actual profitable costs of irrigation water.

Economic considerations require that in the arid region, with

its limited rainfall, irrigation development shall not be finally governed by present cost, but rather by the value of irrigation, and that this alone will ultimately determine the extent of reservoir construction.

The question arises, What is the probable field for storage reservoirs, and how much water must they be called upon to store? To answer this question fully requires a knowledge of the time, value, and duration of flow of the water supply, and of the demands for irrigation water. Also we must know the losses from the reservoir, and the periods of such losses. Reservoir losses consist of evaporation and seepage. The evaporation losses will in general vary from 3 to 7 feet per year in arid regions, and quite extensive data in this respect are available for various places throughout the country, giving the monthly and annual evaporation. Seepage losses are difficult to determine. If the bottom of the reservoir is of water-tight material, losses of this nature will be small; but if the bottom is of a pervious nature, it will be unsuitable for reservoir purposes, and can be made to hold water only by lining the reservoir with impervious material.

According to Elwood Mead, to utilize the entire supply, 40 per cent of the flow of Western rivers would need to be stored for irrigation, while the remainder could be used directly on the land during its irrigation period of June, July, August, and September. In many places irrigation is practically impossible on any scale, without the use of reservoirs, since the rainfall may be so uncertain, and the drainage area so rugged and unprotected, that there will be no water available at times when it is most needed for irrigation. In that event practically all irrigation water must be stored.

Artesian wells used for irrigation in Southern Texas, are usually provided with storage reservoirs of sufficient capacity to store a few days' supply of water. The irrigation factor there, which is the percentage of the year during which the output of the well is actually used, averaged only 20 per cent. In other words, four-fifths of the supply was not used, and in the majority of cases went to waste. This makes the expense of water, which consists of the interest on the cost of, and of the depreciation of the wells, five times as great per unit quantity of water, as if the entire supply had been used. If there had been a storage reservoir of sufficient capacity to have held the

supply of water delivered throughout the year, then if 20 per cent of the yearly output were lost in evaporation and seepage, the well would have furnished four times as much available water, and would have irrigated four times the area.

If the fixed charges on the reservoir were the same as on the well, then if the reservoir cost three times as much as the well, the cost per unit of water would be the same. If the reservoir were more expensive, then it would pay better to put down more wells, provided each well gave the same quantity of water. This, however, will not be the case, as in general the wells will interfere with each other more or less, and in some cases may give but little total increase over the flow from only one well. The fact of being able to multiply fourfold the available irrigable area is no small argument for reservoir construction.

There is still a large field for the construction of reservoirs of small capacity — say of a capacity sufficient to hold from twelve hours' to a week's supply. Many pumping plants operate for only 12 hours per day, as night irrigation is not generally desirable. This results in having to install plants far larger than would otherwise be necessary. In Southern Texas the irrigation factor of the pumping plants was only 14 per cent. In other words, on the average the plants ran only one-seventh of the time. The total fixed expenses of the plants, consisting of interest and depreciation, were about equal to the sum of the labor and fuel expenses, while in the average case the fixed expenses were about three times the sum of the average labor and fuel expenses. The labor expense was a comparatively small item. Many of the plants operated only 12 hours a day, thus necessitating a greatly increased first cost of plant over what would be necessary with the use of a reservoir and a smaller plant, for as labor is so cheap, the cost of pumping would be much reduced, and the initial investment also, by operating the plant continuously night and day, storing the water pumped at night, in a reservoir.

The advantages of small reservoirs are numerous and have already been discussed (see p. 48). Suffice it to say, that many very small pumping plants, realizing the advantage to be derived, have constructed reservoirs to aid in the operation of the plants.

To give some idea of the present cost of irrigation water, the

average cost of pumped water in Southern Texas in 1904, using *straight* averages was \$12 per acre-foot, and the average cost per acre irrigated was \$16 to \$20, while the cost of irrigation, using the *weighted* averages, was from \$5 for steam plants under low lifts, to \$18 for gasoline plants, per acre, per year, the average being \$6 for all plants and \$12 for plants not used for rice irrigation. As the average depth for gasoline plants was 1.0 foot, the maximum average cost of water was \$18 per acre-foot. The highest price paid for water for irrigation in Southern Texas was \$50 per acre-foot. This water was delivered from a pipe line. This cost, it is true, is excessive for anything except truck irrigation. One thing particularly noticeable about irrigation is that the depth of water used varies inversely with the cost, and that high cost tends to economical use of water. If the same quantity of water were to be used when water is dear, as is used when it is cheap, the irrigation would be impracticable. However, by more careful distribution and use, the farmer finds he can get along with a far smaller quantity of water, and the high cost is no longer prohibitive.

The depth of irrigation water varies largely with the crop, soil, climate, and cost, not to mention the irrigator himself. In arid climates the depth usually applied is 2 to 5 feet. Where the water is distributed with care, a depth of 2 feet will often provide sufficient irrigation unless conditions are unfavorable. In semi-arid climates where the water is skillfully used, and the soil suitable, frequently not over 1 foot of irrigation water is employed per year; and often great benefits are derived from 6 inches, judiciously used. In some sections as much as 10 feet are used per year, but this is excessive.

The value of irrigation depends on the crops, the seasons, and the distance to market. For truck, it is not uncommon for irrigation to be worth from \$100 to \$300 per acre, and in some cases as high as \$1500. The total value of field crops will vary from \$20 to \$80 per acre, and irrigation will be worth, for such purposes, up to as high as \$50 per acre. These figures have been given in order to furnish some idea of the values and costs of irrigation, and to have a standpoint, somewhat indefinite it may be said, from which to view the possibilities of storage of water for irrigation. The problem is quite complex from the number of variables which must enter into it. Each case

should be figured out for itself, as it is absolutely impossible to lay down figures for general guidance.

Great economic advantages may be derived from the use of reservoirs and storage tanks, both large and small; and, as will be shown, they may be made effective, not alone in increasing the available irrigable area, but also by diminishing largely the first cost and operating expenses of lands irrigated by pumping plants and artesian wells, as well as by gravity systems. Investigations show that where the ground is at all suitable, large reservoirs may be constructed entirely in embankment, on level or gently sloping ground, at a less cost than the average cost of construction of natural reservoirs now built. There are many places in the country where such reservoirs can be constructed, where no natural site now exists. This is most significant, when it is fully understood. Water may even be pumped to considerable elevation, and stored in reservoirs constructed in embankment, and supplied therefrom at prices comparable with present costs of pumping alone, so that places without present irrigation facilities may come under its beneficial influence. There are many elements entering into the economic construction of reservoirs of this nature, but if all necessary data are given, the design of the reservoir can be figured mathematically to deliver a given quantity of water at as cheap a cost as possible. Engineers may differ as to the probable values to be assigned to the various costs, but the principles of determination of dimensions remain the same. In any given case it would doubtless be possible, if the reservoir be large, to have a site possessing some natural advantages, even on comparatively level ground. The figures given for large reservoirs, and the method employed, will probably be useful, not so much in an individual case, owing to the variation of conditions encountered, as to direct attention to the feasibility, or lack of feasibility, of such undertakings, and to suggest alternative plans for irrigation and reservoir projects. It is particularly necessary to verify, as far as possible, the assumptions for any actual case, and to note the effect of changes in the assumptions which might be liable to occur.

CHAPTER XIII.

EARTH TANKS.

THE small earth tank has an important position in many kinds of irrigation on a small scale, where the supply is of limited capacity. It is, however, not uncommon to see tanks constructed at a cost fully twice as great as should be the case.

The section of a reservoir to be adopted depends in part on the land which it is desired to allot to it, but it should be remembered that the circle has a larger area for a given perimeter than any other figure, and hence on level ground circular reservoirs will contain considerably less material in the banks for a given capacity. Thus a square tank will have 13 per cent more material in its banks than a circular tank of the same capacity, and hence will cost 13 per cent more. With a rectangular tank the expense will be increased to considerably greater extent. Thus, for example, a rectangular tank twice as long as it is wide, and of the same area as a square tank, will have a perimeter 6 per cent greater than the equivalent square, and 20 per cent greater than the equivalent circle. If the rectangular tank be of three times greater length than its width, it would have a perimeter 15 per cent greater than the equivalent square, and 31 per cent greater than the equivalent circle, though the increased volume of the banks may not be quite as great as these figures would show. In considering the reservoir problem, all reservoirs will be assumed to be of circular section unless specifically stated to the contrary. *All linear dimensions will be in feet, and cubical contents of the reservoir banks will be in cubic yards; reservoir capacities will be in acre-feet.*

The common method in use in figuring reservoir capacity of small earth tanks is to figure the entire capacity from the bottom of the reservoir to the top of the bank. This method is both misleading and erroneous, since without pumping from the

reservoirs, the water cannot be drawn below the level of the ground, and the reservoir should not be filled level with the top of the banks, but a safe margin must be left to provide for wave action. This margin, which is the vertical distance between the top of the bank and the highest safe water level in the reservoir, we shall call clearance. It should depend largely on the size of the reservoir, and, unless specified to the contrary,

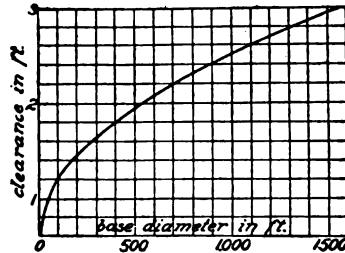

Fig. 30. Reservoir Clearance.

it will be defined by the equation, $b = \text{clearance} = 0.06 (10 + \sqrt{d})$ feet, up to a clearance of 3 feet, after which it will remain constant for larger diameters. In this equation $d =$ inside base diameter of the reservoir in feet. The relation between clearance and inside base diameter is graphically represented in the curve in Fig. 30. Thus, for example, to find the clearance for a reservoir of 900 feet inside base diameter,

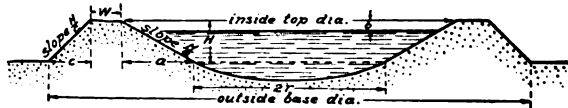

Fig. 31. Reservoir Capacity Diagram.

follow the vertical line representing 900 feet up to the point where it strikes the curve. The corresponding vertical distance as measured by the vertical height of this line is 2.4 feet. The proper clearance depends on the exposure of the reservoir to winds, and on the probable intensity of the winds. The actual capacity of the reservoir we shall figure as that capacity which is included between the elevation of the lowest original ground level in the reservoir and that of the highest safe water level, defined by allowing for the clearance, as above (see Fig. 31).

Stevenson's formula for the relation between the wave height, H ft., due to wind and the fetch, F , nautical miles, is as follows:

$$H = 1.5 \sqrt{F} + 2.5 \sqrt[3]{F} \text{ or expressing the fetch in feet } D.$$

$$H = .0191 \sqrt{D} + .281 \sqrt[3]{D}.$$

The formula gives the following results:

D =	100	H = 1.08
	400	1.64
	900	2.11
	1600	2.53
	2500	2.94
	5000	3.71
	10000	4.72
	20000	6.02

Throughout the remainder of this discussion three general cases will be considered in reservoir construction:

Case 1. — Where the reservoir banks are built on a slope of 3 horizontal to 1 vertical on the inside, and 2 to 1 on the outside.

Case 2. — Where the slope of the bank is 2 to 1 on the inside, and 1.5 to 1 on the outside.

Case 3. — Where the reservoir is lined, inside and outside slopes being 1.5 to 1. The reservoirs will be considered to be constructed on level ground, and no allowance will be made in the capacity of the reservoir for dirt which may be excavated from banks below the level of the ground, the lowest plane to which the water may be drawn in the reservoir being considered as that of the ground level. The following notation will be adopted, linear dimensions being in feet:

- H = vertical depth of reservoir bank.
- S = 1 divided by inside slope of reservoir.
- P = 1 divided by outside slope of reservoir.
- W = crown of reservoir bank.
- Y = cubic yards of earth in the reservoir.
- r = radius of inside base of reservoir.
- r' = radius of reservoir at the top of the water line.

- In Case 1, $S = 3$ $P = 2$.
- In Case 2, $S = 2$ $P = 1.5$.
- In Case 3, $S = P = 1.5$.

On page 219 in the Appendix is given the method of calculation of reservoir capacities, and of the volumes of earth in embankments.

Capacity of reservoir in Case 1 = $(r'^3 - r^3) \times (0.00000801) -$ acre-feet, and the flow in gallons per minute required to fill the reservoir in 24 hours is $(r'^3 - r^3) \times 0.00181$.

For Case 2, acre-feet capacity of reservoir equals $0.00001201 (r'^3 - r^3)$; and gallons per minute required to fill reservoir in 24 hours = $(r'^3 - r^3) .002715$.

In Case 3, acre-feet capacity equals $0.00001602 (r_1^3 - r^3)$, and the gallons per minute required to fill the reservoir in 24 hours = $(r_1^3 - r^3) 0.00362$.

As the use of small reservoirs in irrigation work is quite extended, several tables have been prepared to aid in the computation of capacities of reservoirs and the volumes of earth in the embankments of the same. Two units of capacity are used — the acre-foot of water, and the flow in gallons per minute required to fill the reservoir in 24 hours. Reservoir capacity is often conveniently expressed in the hours or days required for the rate of supply to fill the tank. For instance, say the reservoir is required to hold 5 days' continuous supply of a pump delivering 40 gallons per minute. This is equivalent to 200 gallons per minute for one day. Looking in Table VIII, the required capacity is 0.88 acre-foot. Any diameter of reservoir may be assumed from which the corresponding depth of water may be calculated for a given capacity. Then allowing for a safe distance between the top of the water and the top of the bank, the volume of bank may be figured. In general it will appear that there will be greatly different volumes of earth in the banks for the different depths of water for reservoirs of the same capacity. It is to avoid figuring these quantities that the tables and curves referred to have been given.

Table LXVIII gives capacities of various cone reservoirs for each foot in depth. (See p. 205.)

Table LXIX gives data with reference to the circular reservoirs for Case 1. (See page 209.)

Table LXX gives corresponding data with Case 2. (See p. 212.)

The capacities in Tables LXIX and LXX are calculated on the assumption that the reservoir is filled to the top of the bank and has no clearance. Column 1 gives inside base diameter

(2 r) of the reservoir. Column 2 gives vertical depth of reservoir (H). Column 3 gives top inside diameter of reservoir. Column 4 gives capacity of reservoir in acre-feet when filled level with the top. Column 5 gives flow in gallons per minute necessary to fill

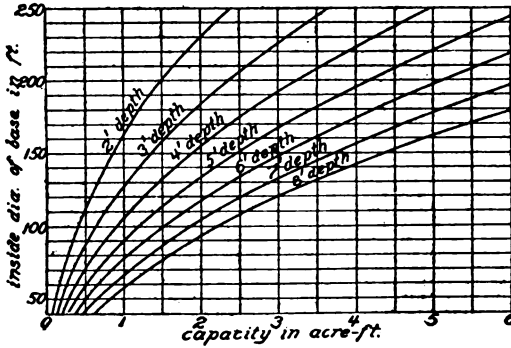

Fig. 32. Reservoir Capacities for Different Water Depths. Case 1.

the reservoir in 24 hours. Columns 6, 7, and 8 give cubic yards of earth in embankment, with crowns of 3, 4, and 5 feet respectively. Column 9 gives outside base diameter of reservoir with 4-foot crown. Column 10 gives length of side of inside

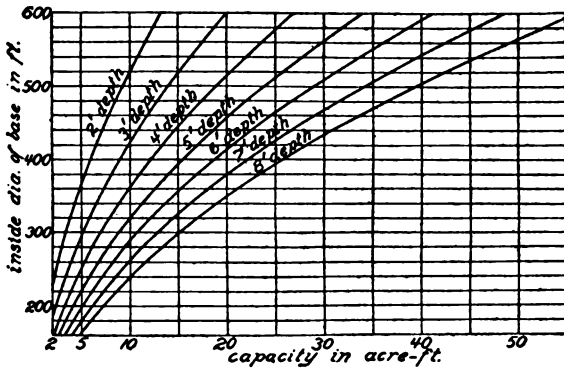

Fig. 33. Reservoir Capacities for Different Water Depths. Case 1.

base of equivalent square reservoir. Column 11 gives length of side of top inside of equivalent square reservoir. Column 12 gives length of base outside of equivalent square reservoir, with 4-foot crown. Figs. 32 and 33 represent graphically the capaci-

ties in acre-feet of reservoirs of various base inside diameters and depths of water. Each curve in these figures, which represent part of Table LXIX, Case 1, is drawn for a given depth of water in the reservoir, and represents the relation existing

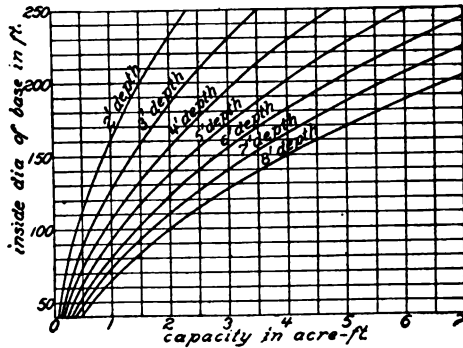

Fig. 34. Reservoir Capacities for Different Water Depths. Case 2.

between the inside base diameter and the capacity of the reservoir in acre-feet. As an example of the use of these curves, suppose that it was desired to build a reservoir with a capacity of 2.5 acre-feet with a depth of 5 feet of water. Looking along

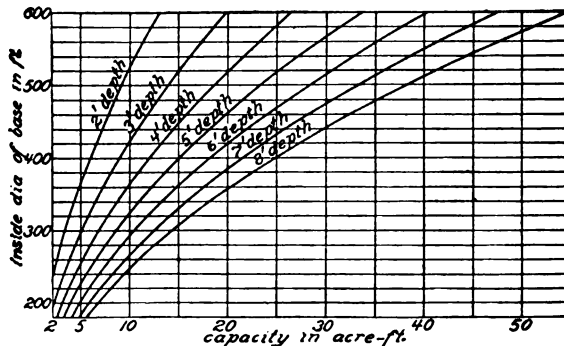

Fig. 35. Reservoir Capacities for Different Water Depths. Case 2.

the vertical line representing 2.5 acre-feet in capacity, note the point at which it crosses the curved line representing a reservoir 5 feet in depth. The corresponding inside base diameter of the reservoir is 151 feet. Should it be desired to build this reservoir

to the water depth of 4 feet, similarly the inside base diameter of the reservoir would be 175 feet. Figs. 34 and 35 show similar curves for Case 2.

Figs. 36 and 37 represent graphically the relation existing

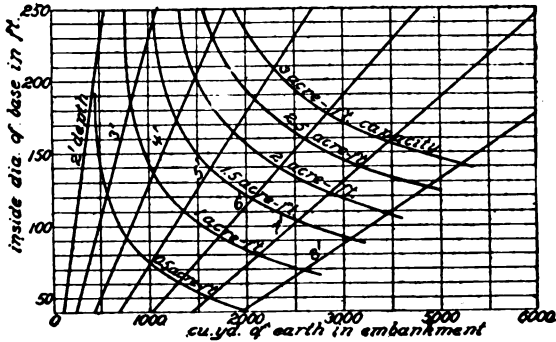

Fig. 36. Capacities and Volumes of Embankment. Case 1.

between the inside base diameter and the cubic yards of earth in the embankment in the circular reservoir for Case 1, the crown being 4 feet. The straight lines running diagonally across the sheet represent the relation existing between the inside base

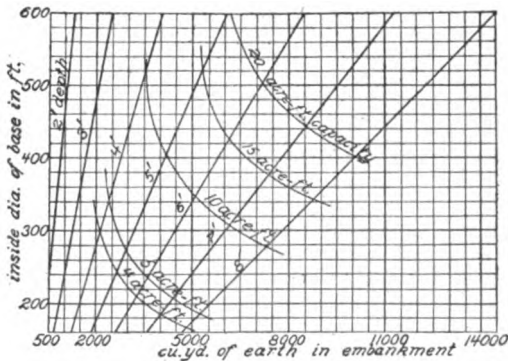

Fig. 37. Capacities and Volumes of Embankment. Case 1.

diameter and the cubic yards of earth in the reservoir embankment for various depths of embankment. Thus, for example, if it were desired to tell the cubic yards of earth in the embankment of a reservoir 500 feet inside base diameter and 5 feet

deep, follow the diagonal line representing 5 feet in depth until it crosses the horizontal line marked 500. The horizontal distance of this line from the zero vertical line represents the

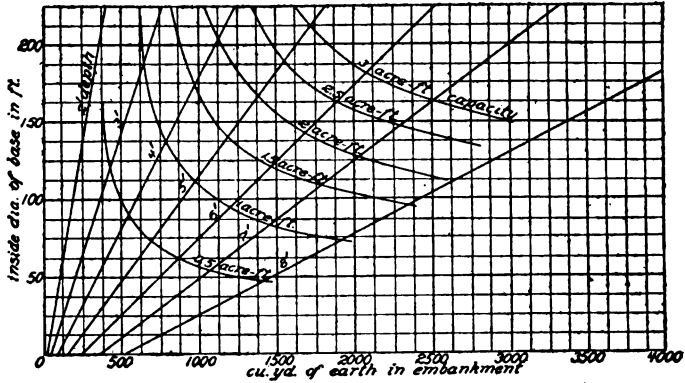

Fig. 38. Capacities and Volumes of Embankment. Case 2.

cubic yards of earth in the embankment of the reservoir which, in this case, is 5150. At 10 cents per cubic yard, this would cost \$515 for the construction. On the same

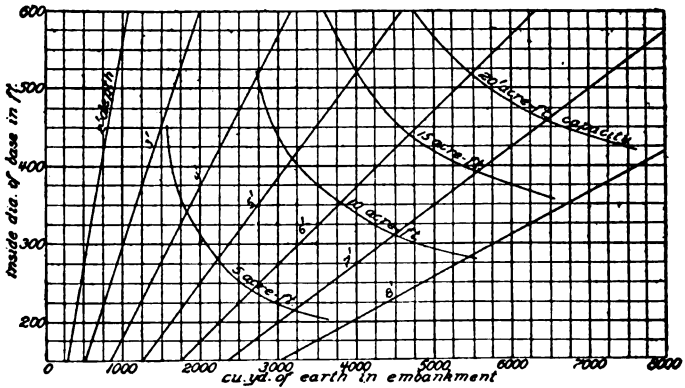

Fig. 39. Capacities and Volumes of Embankment. Case 2.

sheets are drawn curved lines which represent the relations existing between the inside base diameter, depth of reservoir, and cubic yards of earth in embankment. These lines are drawn for various capacities of reservoirs, the assumed clearance

being allowed for in the figures. Thus, for example, suppose it is desired to construct a reservoir to hold 10 acre-feet of water. Follow along the curved line marked 10 acre-feet; note the point

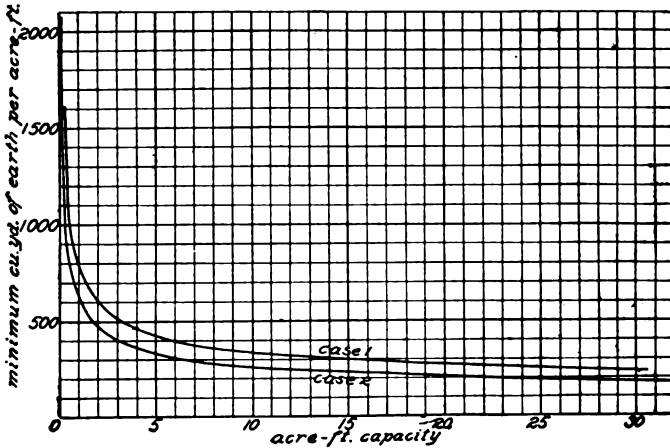

Fig. 40. Minimum Volumes of Embankments for Different Capacities.

of intersection of this curved line with the straight diagonal line. The horizontal distance to such point of intersection from

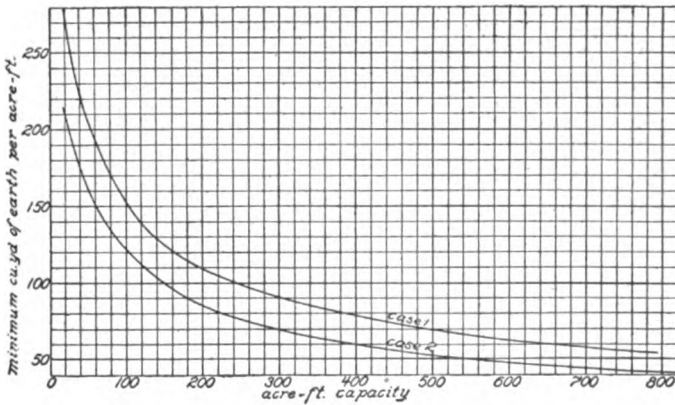

Fig. 41. Minimum Volumes of Embankments for Different Capacities.

the zero line represents cubic yards of earth in embankment, whereas the vertical distance above the zero line represents inside base diameter in feet. Thus it will be seen that the

reservoir may be constructed with banks 4 feet deep, with an inside base diameter of 520 feet, with 3600 cubic yards of earth, or it may be constructed with banks 5 feet deep, 405 feet inside

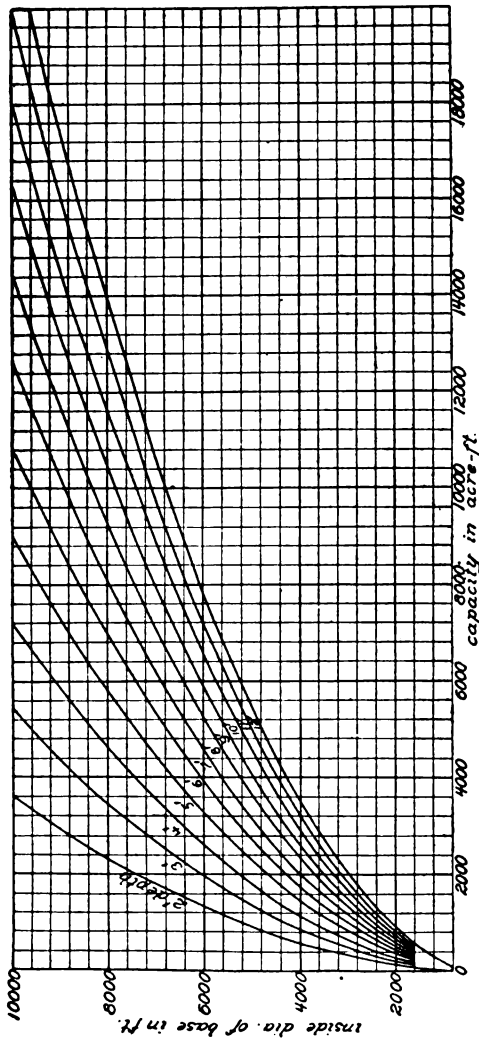

Fig. 42. Reservoir Capacities for Different Water Depths. Case 1.

base diameter, with 4200 yards of earth, or 6 feet deep, 346 feet inside base diameter, with 5200 cubic yards of earth, and so on. Figs. 38 and 39 represent similar curves for Case 2. Table LXXII, p. 216, gives coefficients for determining the volume of earth in circular reservoir embankments.

Figs. 40 and 41, Tables LXXIII and LXXIV, pp. 217 and 218, give the dimensions of reservoirs of various capacities constructed with a minimum amount of earth in the embankment to attain that capacity for Cases 1 and 2. They indicate also the relation between the capacity, volume of earth in embankment, and volume of earth per acre-foot of

capacity. They are calculated according to the laws of clearance specified in the tables. To illustrate the use of the tables, assume that it is desired to construct a reservoir of 31 acre-feet capacity,

Case 1. What is the minimum amount of material which can be used in the reservoir embankment, and what must be the corresponding inside base diameter and depth of the reservoir? Taking the vertical line marked 31 in Fig. 40, note the point

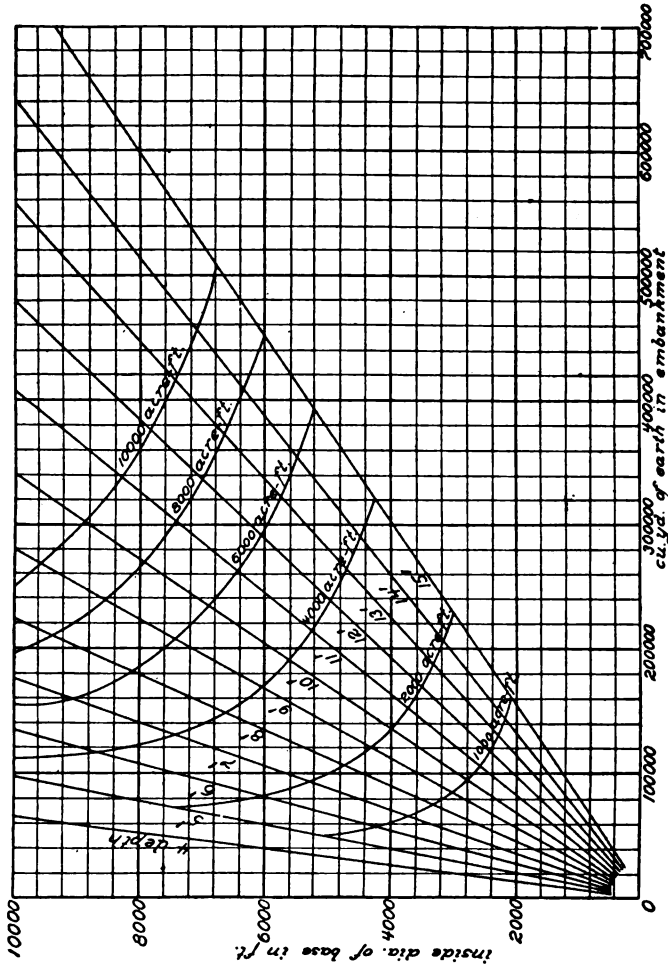

Fig. 43. Capacities and Volumes of Embankment. Case 1.

where this crosses the curve 1, which is at a vertical distance 235 on the scale above zero, thus indicating that 235 cubic yards of earth are required for 1 acre-foot of capacity. Hence the reservoir embankment requires 7300 cubic yards of earth. From Table LXXIII it will be seen that this would call for an

inside base diameter of 1000 feet and depth of embankment of 4.2 feet. Also that the depth of water would be 1.7 feet.

A study of these curves indicates that for a reservoir of given capacity the depth should be relatively exceedingly small in order to construct it as cheaply as possible, the expense of construction being figured at merely a given rate per cubic yard of material in the embankment. Practical consideration of the

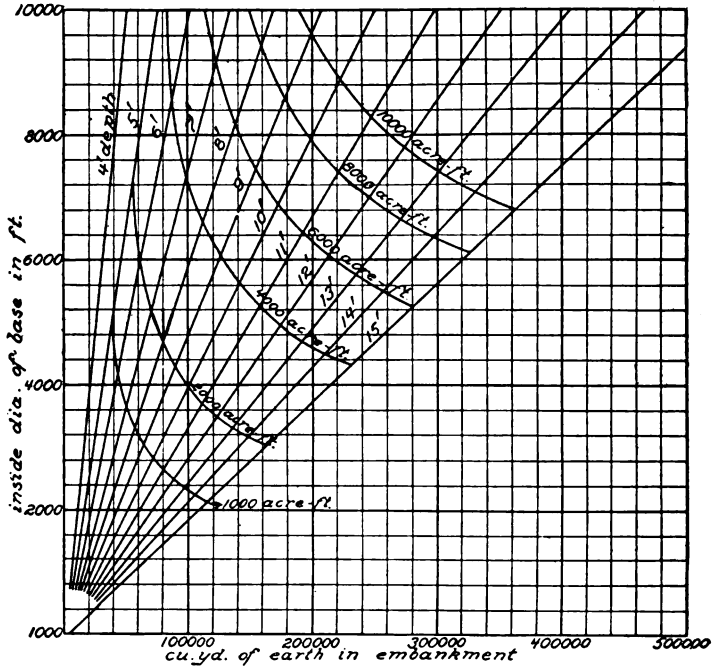

Fig. 44. Capacities and Volumes of Embankments. Case 2.

use to which the reservoir is to be put will largely modify the best proportions of diameter and base for a given capacity, the proper dimensions being arrived at only after thorough considerations of all the various features of the case. For example, evaporation from reservoirs will preclude the use of shallow construction, provided the water must be retained in the reservoir for a considerable period of time. The value of the land also necessitates economy in the area occupied by the reservoir, and calls for deeper reservoirs than would otherwise be advisable.

Where the clearance is 3 feet and is taken as a constant the most economical depth of water in the reservoir is 1.23 feet in Case 1, and 1.3 feet in Case 2.

A study of the curves of Figs. 36 to 39, however, indicates that considerable variation may be made in the depth of reservoirs of given capacity without affecting to any great extent the total volume of earth in the embankment. The table of minimum volumes of earth is chiefly useful as a guide in determining the relative cost of reservoirs of given capacity. Table LXXI, page 215, and Fig. 42 indicate the relation existing between the capacity in acre-feet and the depth of water in large circular reservoirs in Case 1. The values in Case 2 are very nearly the same for reservoirs of such large capacity.

Fig. 43 represents the relation between diameter volumes of embankment, depth, and capacities of large reservoirs, Case 1 allowing for clearance of 3 feet, and Fig. 44 represents corresponding relations for Case 2.

CHAPTER XIV.

LARGE ARTIFICIAL RESERVOIRS.

THERE are many localities in the country where for part of the year large amounts of water go to waste. Where no natural reservoir site is obtainable, often no practical consideration has been devoted to the idea of the construction of large reservoirs on level ground for the storage of this water for irrigation. A study of the problem of construction of earth reservoirs on level ground brings out the fact that where the ground is suitable for reservoir construction extensive developments can be made along lines of this nature. It brings out, however, most prominently the importance, from a financial standpoint, of undertaking on a large scale the construction of extensive reservoirs. While it is true that large areas, miles in extent, cannot usually be obtained on level ground, still the cost of construction with a moderate slope is little in excess of the cost on level ground. And the figures of reservoir construction herewith presented indicate that it is well worth considering and investigating thoroughly the problem of the construction of almost the entire reservoir embankment, utilizing at the same time whatever natural advantages may be found in the location of the site. In problems of this nature it is particularly important to figure carefully all the various items affecting reservoir construction, probable supply of water, and season thereof, evaporation, seepage, and the needs of the land for irrigation. Also cost of construction of embankment and of riprap. Upon making the necessary assumptions of these quantities, mathematical expressions can be derived from which it is possible to determine the proportions of the reservoir which will give a minimum annual cost for any given number of acre-feet output of reservoir.

The following notation will be used for reservoir calculations, *all linear dimensions being in feet, and all costs in dollars.*

A = acre-feet capacity annually available for irrigation after allowing for seepage and evaporation.

$$B = b + g - k.$$

$$C = b + g + d - c - k.$$

D = total annual cost = interest on and depreciation and maintenance of reservoir + cost of water supplied to the same.

$$E = \frac{D}{A} = \text{cost per acre-foot of water supplied from reservoir.}$$

H = Depth of bank.

$$P = \frac{1}{\text{slope of outside bank}}.$$

$$S = \frac{1}{\text{slope of inside bank}}.$$

$$T = \frac{(P + S)}{2}.$$

$$R = \frac{r}{100}.$$

W = crown of bank.

b = clearance.

c = depth in reservoir of annual evaporation and seepage.

d = annual rainfall.

g = depth in reservoir of evaporation + seepage loss during the irrigation season.

i = annual rate of interest.

k = depth of water supplied to the reservoir during irrigation season.

l = cost per acre-foot of water delivered to the reservoir.

m = cost of riprap per square foot.

n = cost of construction of embankment per cubic yard.

p = per cent annual interest and depreciation and maintenance of the reservoir complete.

r = inside radius of reservoir.

v = cost of land per acre.

q = an assumed constant.

Width of belt of riprap = $S(H - q)$, will be assumed in some cases.

The annual depth of water output from the reservoir = $H - b - g + k = H - B$.

Annual depth of water which must be supplied from sources other than rainfall to the reservoir = $H - b - d - g + c + k = H - C$.

It is assumed that there is no rainfall during the irrigation season. In the appendix, page 220, is given in detail a mathematical treatment of the method of obtaining the most economical proportions of the reservoir for minimum annual cost per acre-foot output. In the consideration of the problem it may be stated as a general rule that evaporation losses will be greatest during the irrigation season, also during this time there will be, in all probability, periods when a limited amount of water can be supplied to the reservoir from the source of supply, though the amount which can be furnished at such time may be materially less than that which can be supplied during the remainder of the year. To illustrate the results of the application of the methods of reservoir designs cited, the following assumptions will be made:

$$W = 4; b = 3; c = 6; d = 2; g = 4; p = 0.10; i = 0.07; \\ k = 1; q = 5; \text{ hence, } B = 6; C = 2.$$

These assumptions mean that the annual evaporation and seepage is 6 feet. The evaporation and seepage during the irrigation season is 4 feet; the annual rainfall 2 feet, and the depth of water supplied to the reservoir from the source of supply during the irrigation season, 1 foot, no rainfall being supposed to furnish water during that period. The following additional assumptions will be made:

Cost of earthwork = 10 cents per cu. yd., which will hold for short hauls and where labor is cheap. The cost of riprap = 27 cents per sq. yd., or $n = 0.1; m = 0.03$. Under these assumptions the following four cases will be considered.

Case 1-a. — $l = \$0.25$ = cost per acre-foot of water furnished to reservoirs; $v = \$5$ = cost per acre of land; $S = 3; P = 2; T = 2.5$ feet.

Case 2-a. — The assumptions $l = \$0.25; v = \$5; S = 2; P = 1.5$ feet; $T = 1.75$.

Case 1-b. — $l = \$2; v = \$30; S = 3; P = 2; T = 2.5$.

Case 2-b. — $l = \$2; v = \$30; S = 2; P = 1.5; T = 2.5$.

Several other cases of reservoir construction will be calculated, the assumed data being given in Table LXVII, p. 203.

Tables XXXIV, XXXV, XXXIX and XL and curves in Figs. 45, 46, 47 and 48 show the result of these calculations. There are many places in the country where all expenses for pumping water up to a head as high as 80 feet should be covered by a charge of \$2 per acre-foot, provided that stations with an output of about 10 cubic feet per second be operated for about half the time. A cost of \$30 per acre for land is sufficient to cover most cases to be considered, so the conditions of Case *b* may be assumed to represent an extreme case covering the cost of pumping water into a reservoir where the supply is abundant about half the year, mainly when not needed for irrigation. While the results given in the tables, and the curves represent the best proportions of the reservoir, still, should local conditions demand for any reason, such as the lay of the land, the relative dimensions of reservoir may be altered quite widely without materially increasing the annual cost of water. The curves shown in Figs. 45 to 48 are of four kinds. Curve No. 1 represents the relation between the inside diameter of the reservoir and the output capacity in acre-feet. Curve No. 2 represents the relation between the inside diameter and the depth of embankment. Curve No. 3 represents the relation between the inside base diameter and the cost of construction of reservoir and riprap per acre-foot output capacity, and curve No. 4 represents the relation between the inside diameter and the annual cost per acre-foot output of reservoir. For example, if it were desired to have a reservoir delivering 1380 acre-feet of water per year, in Case 1-*b*, follow out the horizontal line marked 1380 acre-feet to a point where it crosses Curve No. 1, the point of intersection will be at a horizontal distance representing 3000 feet. Follow this vertical line to a point where it crosses Curve No. 4. The vertical distance of this point from the zero line shows that the cost of water is \$5.25 per acre-foot. This is less than one-third the actual cost in many localities where irrigation has been successfully carried on. To compare this with other costs, the cost of distribution of this water to various farms should be added. In certain localities, where the water supply is limited, the average cost of gasoline alone for pumping is \$13 per acre-foot. Water supplied from city pipe lines costs from \$48 to \$60 per acre-foot. The amount of water needed for the irrigation of land depends largely on the method of distribution.

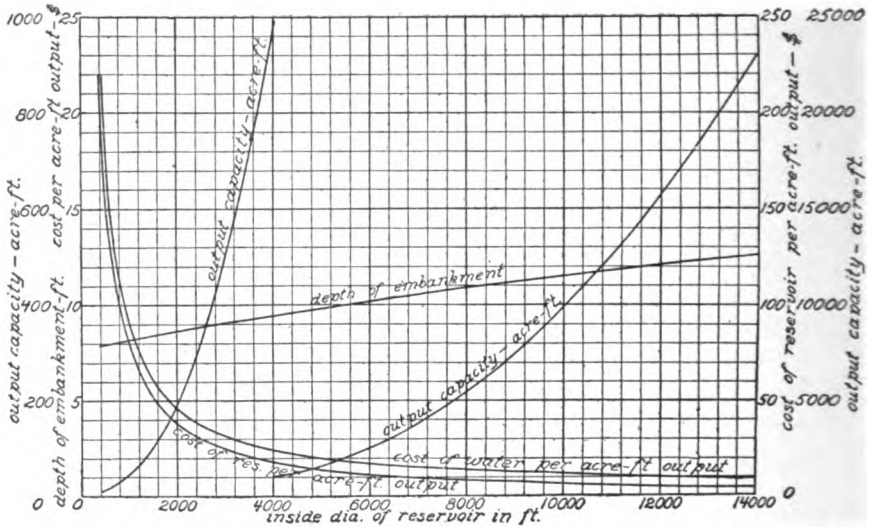

Fig. 45. Economic Reservoir Dimensions and Costs. Case 1a.

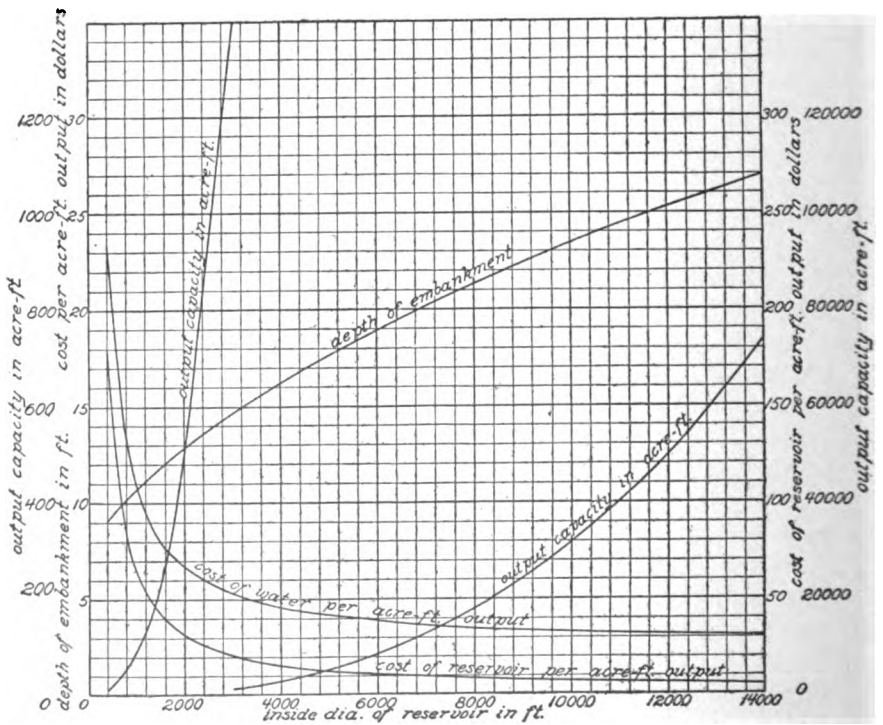

Fig. 46. Economic Reservoir Dimensions and Costs. Case 1b.

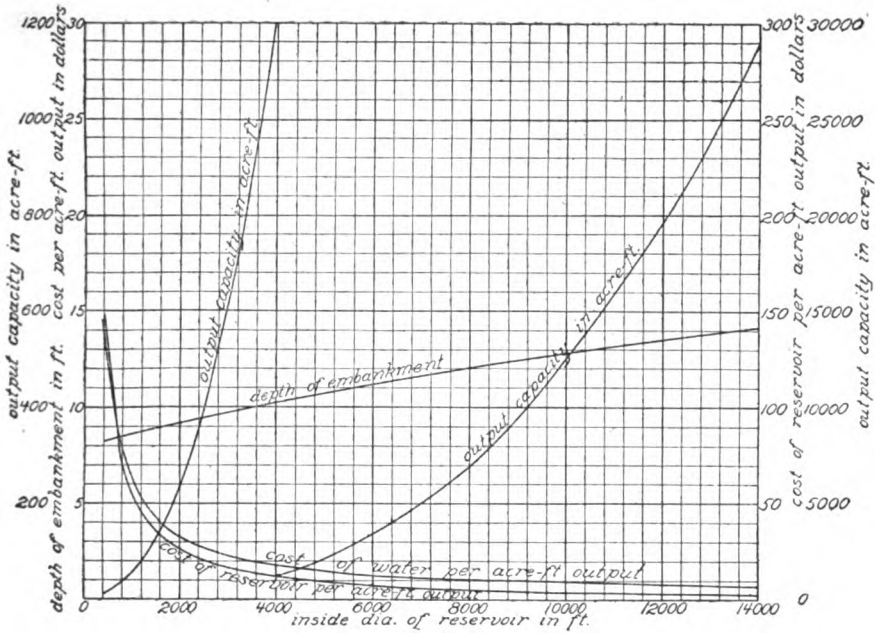

Fig. 47. Economic Reservoir Dimensions and Costs. Case 2a.

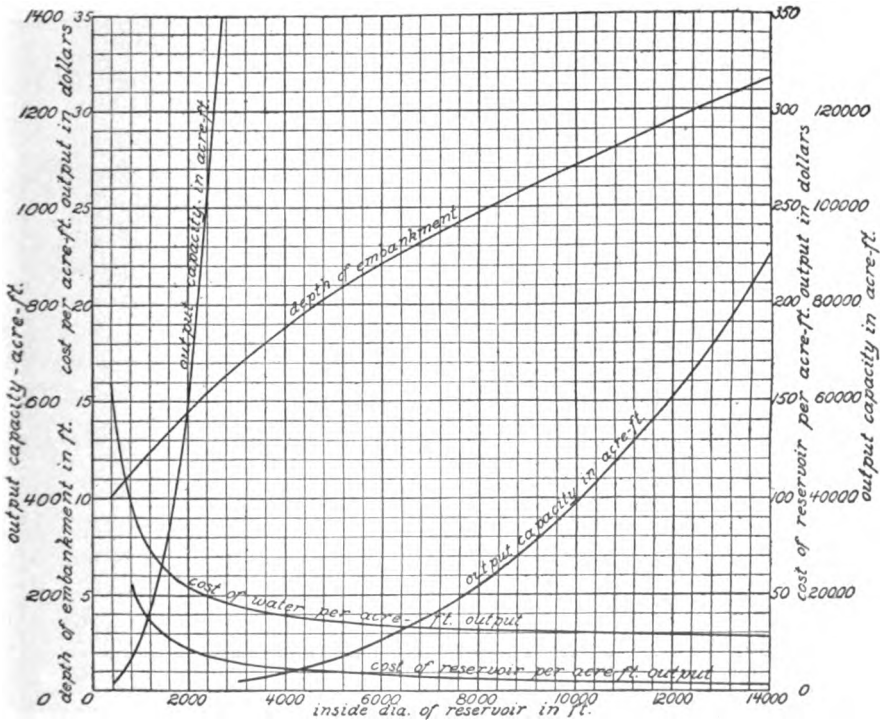

Fig. 48. Economic Reservoir Dimensions and Costs. Case 2b.

The high cost of obtaining water naturally leads to economy in its use. Owing to the high cost, the greatest economy is practised in the distribution of water from pipe lines where irrigation is usually practised by means of hose. In semi-arid countries, where the water supply is limited, considerable economy is practised in the use of water, and very successful results have been attained by using an average depth of irrigation of about 1.25 inches, with an annual depth of about 1 foot. Where the supply is much larger, on the contrary, the water is often used extravagantly. A comparison of these figures with the costs, as indicated for reservoir construction, shows encouraging prospects for the possible storage of water on a large scale.

The proper clearance to allow for reservoirs has been assumed to be dependent merely upon the diameter of the reservoir. However, if the reservoir is of large capacity, the depth of the water, as well as the exposure to winds, should be taken into consideration in assigning a suitable value to this quantity. The top width of the embankment has heretofore been assumed to be 4 feet, but the width of crown will depend upon whether it is desired to use the top of the embankment for a wagon road, in which event it should be made considerably wider. Practically, however, it should be good practice in construction of the upper part of an embankment where lined with riprap, to build the embankment on a steeper slope than lower down, in order to reflect the waves. Thus it is apparent that by the addition of a comparatively small amount of earth the top may be widened considerably. In order to see the effect of increased clearance and greater crown, results have been figured for Case 1c with a 10-foot crown and 5-foot clearance, assuming land at \$5 per acre and the value of water input at 25 cents per acre-foot. Also q is taken as 3. The side slope continues the same to the top of the embankment.

In Case 1aa the assumptions are similar to those in Case 1a except that $q = 3$ instead of 5, meaning a greater width of riprap. This has no important effect on the general proportions.

All tables so far given for reservoir construction have assumed the reservoirs to be built on level ground. As a general rule, however, the ground will have more or less slope. It is quite common to find large tracts of land where reservoirs could be constructed on fairly uniform slopes. In the appendix, page 222,

is given the mathematical method of determining economic reservoirs for sloping ground. Cases *1d* and *1e* are for the determination of economic reservoirs where the ground has a slope of 1 foot per 1000 feet, cost of water input 25 cents per acre-foot, and cost of land \$5 per acre. The cost and proper proportions of reservoirs for these two cases are given in the Tables XXXVII and XXXVIII. Case *1d* is for 3-foot clearance and 4-foot crown. Case *1e* is for 5-foot clearance and 10-foot crown. The costs of reservoirs per acre-foot output refer merely to the cost of construction of embankment and riprap, and do not include the cost of land. The depths of embankments given in these two cases refer to mean depths, the maximum and minimum being easily determined from the slope of the land and the diameter of the reservoirs. Formulæ for sloping land apply only when $r \times$ the slope is less than the mean depth minus the clearance. The most economical reservoir section on land with much slope is not the circular section. Where labor is not cheap and part of the material for construction of the embankment has to be hauled some distance, the cost of such work will be considerably over 10 cents. In cases *1f*, *1g*, *1h* and *1i* a ground slope of 2 feet per 1000 is assumed; the cost of earthwork is 25 cents for *1f* and *1g*, 22 cents for *1h*, and 20 cents for *1i* per cubic yard instead of 10 cents; and fixed expenses 12 per cent per year. In these cases also assume that a belt of riprap, $t = 12$ feet wide and costing 90 cents per square yard, is laid around the reservoir.

Cases *1f*, *1g* and *1i* assume 4-foot crown and 3-foot clearance.

Case *1h* assumes a 10-foot crown and 5-foot clearance.

Case *1i* assumes the reservoir is lined with a 6-inch puddle mixture costing 2 cents per square foot.

Water supplied to reservoir costs 25 cents per acre foot in *1f* and *1h*, and \$2 per acre-foot in *1g* and *1i*.

In case the reservoir will not hold water, it may be lined or puddled. The mathematical method of figuring the most economical dimensions for a lined reservoir is given in the appendix.* If the lining be made of concrete or asphalt, the riprap would not be used, and in this event $t = 0$. Also under these conditions much steeper inside slope can be used, varying from 1 to 1, to 1.5 to 1.

Case *3k* is figured on the assumption of a reservoir lined with

* See page 223.

concrete costing 90 cents per square yard, the cost of water supplied to reservoir being \$2 per acre-foot. The total evaporation and seepage losses are 5 feet instead of 6 feet per year. The clearance is 3 feet, and the cost of earthwork is 20 cents per cu. yd. The reservoirs of this class are naturally exceedingly deep in comparison with others. It is frequently desirable to construct small reservoirs of this nature at a minimum first cost. Formulæ have been deduced (p. 226, appendix) to determine the dimensions of the reservoirs of given capacity and minimum cost. These apply only to large reservoirs, and if applied to those less than 200 feet in diameter may lead to considerable inaccuracy. An approximate method of applying these formulæ by the use of a correction factor, is given in the appendix, p. 226. This is fairly accurate for reservoirs over 100 feet in diameter. Two cases (3*l* and 3*m*) have been calculated, using this method where the cost of earthwork is taken as 15 cents per cubic yard, and the cost of the lining 2 cents per square foot. The crown is 4 feet and the clearance in Case 3*l* is 1 foot, and in Case 3*m* is 2 feet. The results are given in Tables XLVI and XLVII.

To solve the general case accurately for small reservoirs would involve quite complicated equations.

TABLES OF ECONOMICAL PROPORTIONS AND
COSTS OF RESERVOIRS.

TABLE XXXIV.

Case 1a.

COST PER ACRE-FOOT SUPPLIED TO RESERVOIR — 25 CENTS.

Diameter of reservoir, Feet.	Depth of embankment, Feet.	Output capacity, Acre-ft.	Cost of water per acre-ft. output	Cost of reservoir per acre-ft. output capacity	Reservoir efficiency, Per cent
400	8.09	6.03	\$21.84	\$209.40	33
800	8.27	26.20	9.94	90.90	36
1,200	8.46	64.00	7.29	64.90	38
1,600	8.62	121.00	5.52	47.50	40
2,000	8.82	203.00	4.43	37.00	41
3,000	9.21	520.00	3.03	23.60	44
4,000	9.60	1,040.00	2.32	17.00	47
6,000	10.31	2,800.00	1.65	10.90	52
8,000	10.96	5,730.00	1.32	8.00	55
12,000	12.15	15,950.00	.98	5.10	61
16,000	13.20	33,300.00	.83	3.90	64
20,000	14.18	59,000.00	.73	3.10	67

TABLE XXXV.

Case 1b.

COST PER ACRE-FOOT SUPPLIED TO RESERVOIR — \$2.

Diameter of reservoir, Feet.	Depth of embankment, Feet.	Output capacity, Acre-ft.	Cost of water per acre-ft. output	Cost of reservoir per acre-ft. output capacity	Reservoir efficiency, Per cent
400	9.20	9.25	\$22.85	\$177.00	44
800	10.30	49.70	12.52	81.70	52
1,200	11.70	136.80	9.18	52.60	59
1,600	12.15	283.50	7.53	38.90	61
2,000	12.90	500.00	6.55	30.90	63
3,000	14.50	1,380.00	5.25	20.60	68
4,000	16.30	2,970.00	4.56	15.80	72
6,000	19.00	8,410.00	3.88	11.00	77
8,000	21.30	17,650.00	3.41	8.50	80
12,000	25.30	50,200.00	3.13	6.10	83
16,000	28.50	104,100.00	2.94	4.90	85
20,000	31.50	184,500.00	2.81	4.20	87

TABLE XXXVI.

Case 1c.

COST PER ACRE-FOOT SUPPLIED TO RESERVOIR — 25 CENTS.

2,000	12.20	303.	\$6.08	\$55.10	51
4,000	12.80	1,384.	3.14	26.10	55
6,000	13.31	3,450.	2.17	16.70	57
8,000	13.88	6,785.	1.70	12.20	60
12,000	14.87	17,820.	1.22	7.70	63
16,000	15.80	38,150.	.98	5.60	66
20,000	16.65	62,300.	.85	4.40	68

TABLE XXXVII.

Case 1d.

COST PER ACRE-FOOT SUPPLIED TO RESERVOIR — 25 CENTS.

2,000	8.84	205.	\$4.42	\$36.90	42
4,000	9.74	1,075.	2.32	17.10	48
6,000	10.58	2,970.	1.65	11.03	53
8,000	11.41	6,240.	1.32	8.16	58
12,000	13.00	18,180.	.99	5.49	64
16,000	14.40	38,700.	.84	4.25	68
20,000	16.10	72,900.	.74	4.25	72

TABLE XXXVIII.

Case 1c.

COST PER ACRE-FOOT SUPPLIED TO RESERVOIR — 25 CENTS.

Diameter of reservoir, Feet.	Depth of embankment, Feet.	Output capacity, Acre-ft.	Cost of water per acre-ft. output	Cost of reservoir per acre-ft. output capacity	Reservoir efficiency, Per cent
2,000	12.25	306.	\$6.07	\$55.00	52
4,000	12.84	1,395.	3.15	26.17	55
6,000	13.53	3,580.	2.17	16.75	58
8,000	14.24	7,200.	1.67	11.99	61
12,000	15.60	19,720.	1.22	7.89	66
16,000	17.00	41,400.	.98	5.79	69
20,000	18.40	74,600.	.86	4.76	72

TABLE XXXIX.

Case 2a.

COST PER ACRE-FOOT SUPPLIED TO RESERVOIR — 25 CENTS.

400	8.27	6.53	\$14.49	\$146.40	36
800	8.52	29.10	7.78	69.90	39
1,200	8.75	71.90	5.23	44.90	41
1,600	9.00	138.30	3.96	32.60	43
2,000	9.25	232.70	3.22	25.50	45
3,000	9.76	610.00	2.22	16.10	49
4,000	10.26	1,229.00	1.74	11.70	52
6,000	11.19	3,365.00	1.26	7.50	56
8,000	12.03	6,950.00	1.03	5.60	60
12,000	13.52	19,500.00	.79	3.60	65
16,000	14.85	40,750.00	.68	2.80	69
20,000	16.02	72,350.00	.60	2.20	72

TABLE XL.

Case 2b.

COST PER ACRE-FOOT SUPPLIED TO RESERVOIR — \$2.

400	10.03	11.64	\$16.49	\$119.90	50
800	11.15	59.70	9.61	56.60	56
1,200	12.38	166.00	7.26	36.80	61
1,600	13.45	346.00	6.10	27.50	65
2,000	14.48	613.00	5.39	22.00	68
3,000	16.70	1,735.00	4.44	14.90	73
4,000	18.50	3,632.00	3.94	14.90	76
6,000	22.20	10,520.00	3.44	8.20	80
8,000	24.70	21,600.00	3.17	6.30	83
12,000	16.97	61,050.00	2.89	4.60	86
16,000	19.85	127,000.00	2.76	3.90	88
20,000	22.45	224,500.00	2.64	3.10	89

TABLE XLI.

Case 1f.

COST PER ACRE-FOOT SUPPLIED TO RESERVOIR — 25 CENTS.

Diameter of reservoir, Feet.	Depth of embankment, Feet.	Output capacity, Acre-ft.	Cost of water per acre-ft. output	Cost of reservoir per acre-ft. output capacity	Reservoir efficiency, Per cent
400	9.95	11.4	\$51.49	\$423	450
800	10.02	46.4	25.99	222	50
1,200	10.13	107.2	18.31	147.70	51
1,600	10.17	192.5	13.09	104.30	51
2,000	10.27	308.0	10.50	82.80	52
3,000	10.52	733.5	7.06	54.20	53
4,000	10.81	1,388	5.34	40.05	55
6,000	11.58	3,564	3.64	26.20	58
8,000	12.24	7,216	2.81	19.50	61
12,000	13.97	20,700	2.01	13.25	67
16,000	15.87	45,500	1.64	10.42	71
20,000	17.85	85,600	1.43	8.92	75

TABLE XLII.

Case 1g.

COST PER ACRE-FOOT SUPPLIED TO RESERVOIR — \$2.

400	10.31	12.44	\$63.53	\$493	52
800	10.72	54.6	28.21	201	54
1,200	11.14	133.5	17.21	127.20	56
1,600	11.52	254.6	14.99	93.20	58
2,000	11.88	425	12.46	73.10	60
3,000	12.80	1,104	9.15	47.25	63
4,000	13.63	2,204	7.51	35	66
6,000	15.22	5,980	5.88	23.08	70
8,000	16.71	12,370	5.07	17.75	73
12,000	19.72	35,600	4.25	12.67	77
16,000	22.12	74,500	3.85	10.25	80
20,000	24.68	134,800	3.61	8.92	82

TABLE XLIII.

Case 1h.

COST PER ACRE-FOOT SUPPLIED TO RESERVOIR — 25 CENTS.

400	12.64	13.4	\$62.49	\$516	54
800	12.71	54.4	31.31	257	54
1,200	12.79	124	20.82	170	55
1,600	12.86	224	15.73	126.6	55
2,000	12.96	358	12.60	100.6	55
3,000	13.22	848	8.44	66.1	56
4,000	13.55	1,596	6.37	48.8	58
6,000	14.31	4,095	4.08	30.2	61
8,000	15.19	8,288	3.28	23.7	64
12,000	17.27	24,100	2.30	15.9	70
16,000	19.61	53,600	1.86	12.4	74
20,000	22.06	101,500	1.62	10.6	78

TABLE XLIV.

Case 1i.

COST PER ACRE-FOOT SUPPLIED TO RESERVOIR—\$.

Diameter of reservoir, Feet.	Depth of embankment, Feet.	Output capacity, Acre-ft.	Cost of water per acre-ft. output	Cost of reservoir per acre-ft. output capacity	Reservoir efficiency, Per cent
400	14.9	25.3	\$41.18	\$380	69
800	18.0	138	24.20	214	75
1,200	20.5	377	18.35	157	78
1,600	22.8	775	15.29	127	81
2,000	24.8	1,356	13.37	108.3	82
3,000	29.2	3,750	10.68	82.4	85
4,000	32.9	7,752	9.24	68.7	87
6,000	39.2	21,600	7.66	53.6	89
8,000	44.6	44,600	6.80	45.4	90
12,000	54.0	124,600	5.79	35.8	92
16,000	61.9	258,000	5.24	30.6	93
20,000	69.0	455,000	4.87	27.1	94

Case 4a.

COST PER ACRE-FOOT SUPPLIED TO RESERVOIR—25 CENTS.

400	8.1	5.9	\$20.78	\$198.70	34
800	8.3	26.7	8.83	79.90	38
1,200	8.6	66.6	5.89	51.10	39
1,600	8.8	129.8	4.47	37.40	41
2,000	9.0	219	3.65	29.50	43
3,000	9.6	583	2.53	18.00	47
4,000	10.1	1,178	1.99	14.10	51
6,000	11.0	3,260	1.45	9.30	56
8,000	11.9	6,775	1.18	7.00	60
12,000	13.4	19,200	.91	4.70	65
16,000	14.5	39,250	.78	3.70	68
20,000	15.8	70,800	.70	3.10	71

Case 1aa.

COST PER ACRE-FOOT SUPPLIED TO RESERVOIR—25 CENTS.

400	8.6	7.6	\$22.70	\$219.30	39
800	8.9	32.2	11.40	106.60	41
1,200	8.9	76.2	7.66	69.50	42
1,600	9.1	143.0	5.77	50.80	44
2,000	9.3	236	4.65	39.90	45
3,000	9.6	590	3.17	25.50	47
4,000	10.0	1,156	2.44	18.50	50
6,000	10.7	3,042	1.73	11.90	53
8,000	11.3	6,128	1.36	8.60	57
12,000	12.4	16,620	1.02	5.70	61
16,000	13.5	34,560	.85	4.20	65
20,000	14.4	60,800	.74	3.30	68

One other case (No. 4a) of reservoir construction will be considered based on certain data compiled by Professor Fortier, which the following statements will explain. The general assumptions of this case are similar to those in Case 1a, except that the side slopes and widths of embankment at top are different, as will be explained.

As has been pointed out, the proper section of the banks of earth reservoirs depends on the depth of water, exposure to winds, and on the material of which the embankment is composed. The inner and outer slopes must not be so steep that they will not stand up under the action of waves or of the elements. The top of the embankment must have sufficient clearance above the water plane not to allow the waves to wash over it. The particular conditions of each case should be given individual consideration. It is well to take into consideration the practice in existing earth reservoirs.

In bulletin No. 46 of the Agricultural College Experiment Station at Logan, Utah, Prof. S. Fortier gives some interesting figures on earth embankments for reservoirs. From 75 typical earth reservoirs, the following figures were obtained:

The inner slopes varied from 4:1 to 1:1, averaging 2.61:1.

The outer slopes averaged 2.1:1.

The following table gives a summary of these results:

SLOPE OF RESERVOIR EMBANKMENTS.

No. of Reservoirs	Outer Slope	No. of Reservoirs	Inner Slope
2	1:1	2	1:1
23	1- $\frac{1}{4}$:1	23	1 $\frac{1}{4}$:1
2	1- $\frac{1}{2}$:1	2	1 $\frac{1}{2}$:1
41	2:1	31	2:1
1	2- $\frac{1}{4}$:1	1	2- $\frac{1}{4}$:1
3	2- $\frac{1}{2}$:1	1	2- $\frac{1}{2}$:1
3	3:1	11	3:1
Average	2.1:1	2	4:1
		Average	2.61:1

From the same reservoirs it is deduced that the thickness in feet of embankment at the high water line is 5 plus the depth of water in the reservoir.

In Case 4a the following assumptions are made: $S = 2.61$, $P = 2.1$, $W = H + 5 - 2bT$, $b = 3$.

In the practical construction of an earth embankment, Professor Fortier advocates the use of a core wall. A very effective

TABLE XLV.

*Case 3k.***COST PER ACRE-FOOT SUPPLIED TO RESERVOIR — \$₂.**

Diameter of reservoir, Feet.	Depth of embankment, Feet.	Output capacity, Acre-ft.	Cost of water per acre-ft. output
400	27.5	65	\$47.20
800	37.7	378	29.36
1,200	45.4	1,050	23.10
1,600	52.1	2,175	19.66
2,000	58	3,820	17.45
3,000	70.3	10,620	14.20
4,000	80.8	21,880	12.40
6,000	98.5	60,750	10.32

TABLE XLVI.

*Case 3l.***LINED RESERVOIRS CONSTRUCTED FOR MINIMUM FIRST COST.**

Mean diameter bank, Feet.	Depth of bank, Feet.	Acre-ft. capacity	Cost per acre-ft.	Total cost
40	4.49	.0487	\$1,232	\$60
80	6.13	.395	551	217
120	7.40	1.23	381	468
160	8.45	2.69	300	808
200	9.42	4.94	252	1,245
300	11.45	14.48	187	2,730
400	13.13	30.70	156	4,785

TABLE XLVII.

Case 3m.

40	5.45	.038	\$1,906	\$73
80	7.00	.352	698	246
120	8.23	1.141	453	515
160	9.28	2.54	347	882
200	10.20	4.67	287	1,339
300	12.22	13.9	209	2,900
400	13.90	29.7	169	5,028

method of building the center of the embankment is to keep the central portion during construction lower than the two sides, so as to leave a small ditch in the center. This is kept partially full of water; during the day the water is quite low, not to interfere with working, and at night the water level is raised.

The construction of an embankment impervious to water involves in the main, the proper arrangement of various sizes of soil grains, the effective filling of interstices, the consequent

TABLE XLVIII.

**COST OF RESERVOIR CONSTRUCTION PER ACRE-FOOT —
AMERICAN RESERVOIRS.**

(Taken from Schuyler's "Reservoirs for Irrigation, Water Power and Domestic Water Supply.")

No.	Name	Character of dam	Capacity of reservoir, Acre-ft.	Cost	Cost per acre-ft.
1	Sweetwater dam, Cal.	Masonry	22,566	\$264,500	\$11.72
2	Bear Valley dam, Cal.	Masonry	40,000	68,000	1.70
3	Hemet dam, Cal. . .	Masonry	10,500	150,000	14.29
4	Escondido dam, Cal.	Rock-fill	3,500	110,059	31.44
6	La Mesa dam, Cal. .	Hydraulic-fill . .	1,300	17,000	13.10
7	Cuyamaca dam, Cal.	Earth	11,410	54,400	4.76
8	Buena Vista Lake, Cal.	Earth	170,000	150,000	.88
10	English dam, Cal. .	Rock-fill crib . .	14,900	155,000	10.40
11	Bowman dam, Cal. .	Rock-fill crib . .	21,070	151,521	7.19
12	San Leandro dam, Cal.	Earth	13,270	900,000	68.00
13	Eureka Lake dam, Cal.	Rock-fill	15,170	35,000	2.32
14	Fancherie dam, Cal.	Rock-fill	1,350	8,000	5.92
15	Lake Avalon, Pecos River, N.M.	Rock-fill and earth	6,300	176,000	27.94
16	Lake McMillan, Pecos River, N.M.	Rock-fill and earth	89,000	180,000	2.02
17	Tyler, Texas	Hydraulic-fill . .	1,770	1,140	.64
18	Cache la Poudre, Col.	Earth	5,654	110,266	19.50
19	Larimer and Weld, Col.	Earth	11,550	89,782	7.77
20	Windsor, Col. . . .	Earth	23,000	75,000	3.26
21	Monument, Col. . .	Earth	885	33,121	38.69
22	Apishapa, Col. . . .	Earth	459	14,772	32.18
23	Hardscrabble, Col. .	Earth	102	9,997	97.78
24	Boss Lake, Col. . . .	Earth	205	14,654	71.39
25	Saguache, Col. . . .	Earth	954	30,000	31.45
26	Seligman, Ariz. . . .	Masonry	703	150,000	169.50
27	Ash Fork, Ariz. . . .	Steel	110	45,776	416.30
28	Williams, Ariz. . . .	Masonry	338	52,838	156.35
29	Walnut Cañon, Ariz.	Masonry	480	55,000	114.60
30	New Croton, N.Y. . .	Masonry and earth	98,200	4,150,573	42.27
31	Titicus, N.Y.	Masonry and earth	22,000	933,065	42.42
32	Sodom, N.Y.	Masonry and earth	14,980	366,990	24.50
33	Bog Brook, N.Y. . . .	Earth	12,720	510,430	40.12
34	Indian River, N.Y.	Masonry and earth	102,548	83,555	.81
35	Wigwam, Conn. . . .	Masonry	1,028	150,000	145.90
	Total		730,012	9,296,439	
	Average				12.71
	Mean capacity		22,100		

Average capacity exclusive of No. 8, 17,500 acre-feet.
Average cost per acre foot exclusive of No. 8, \$16.32.

TABLE XLIX.
DATA CONCERNING AMERICAN RESERVOIRS.

Name	Surface area, Acres	Maximum height, Feet	Rated capacity, Acre-ft.	Corrected capacity, Acre-ft.	Cost per acre-ft. corrected capacity	Rated capacity, divided by surface area, Feet
1 Sweetwater . . .	895	76	22,566	19,881	\$13.30	27.0
2 Bear Valley . . .	3,300	80	40,000	30,000	2.20	12.0
3 Hemet	738	150	10,500	8,286	18.05	14.0
4 Escondido	285	110	3,500	2,645	41.70	12.0
5 Lower Otay	1,414	150	42,190	37,948	...	30.0
6 La Mesa	70	140	1,300	1,090	15.60	19.0
7 Cuyamaca	959	35	11,410	8,533	5.50	13.0
8 Buena Vista . . .	25,000	10	170,000	95,000	1.56	6.8
12 San Leandro . . .	715	170	2,145	13,270	74.20	19.0

expulsion of the air therefrom, and the protection of the banks from extreme drought or saturation. Professor Fortier considers that the construction of the embankment as outlined gives most satisfactory results, since there is no method of

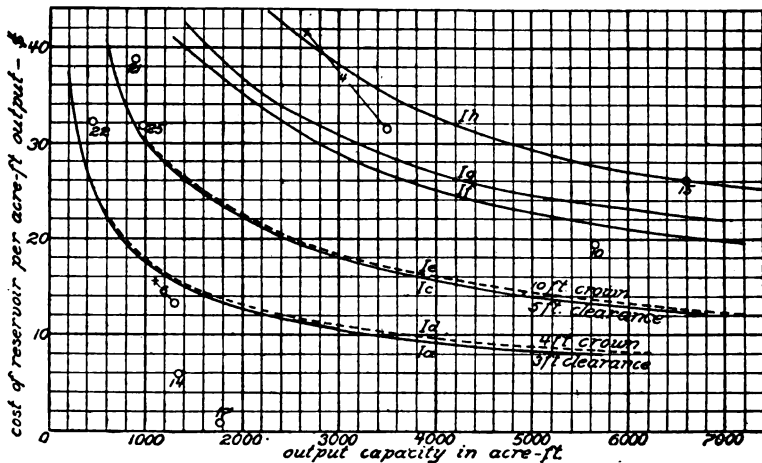

Fig. 49. First Costs of Artificial and Natural Reservoirs.

arrangement and compacting of the soil grains, which will give results superior to those attained by the use of water.

Table XLVIII, which shows the cost of American reservoirs,

makes no allowance, however, for loss by evaporation. In the majority of natural reservoirs the storage capacity per foot of depth increases very rapidly toward the highest water level, the lower part of the reservoir being of comparatively little value as a storage basin. In consideration of the evaporation we would be more nearly correct if we assume the top area as subject to evaporation rather than the area obtained by dividing the total capacity stored by the maximum depth. Since the greater part of the

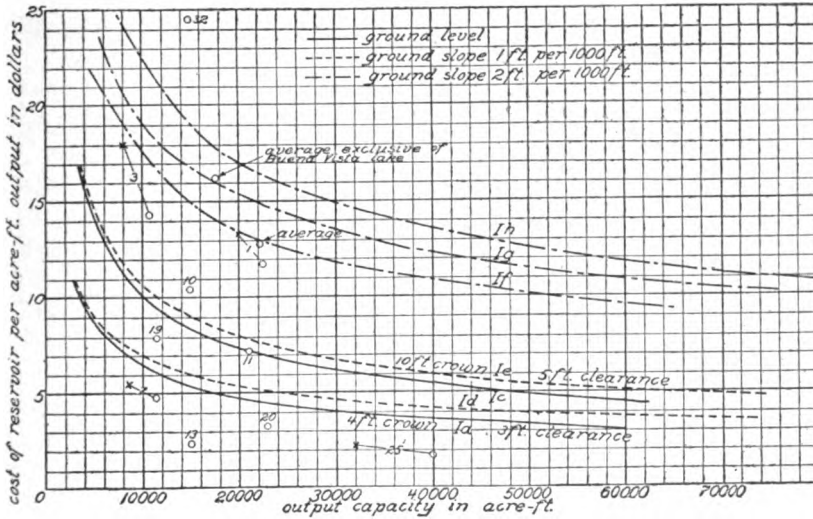

Fig. 50. First Cost of Artificial and Natural Reservoirs.

storage is in the upper part of the reservoir a much greater surface will be presented for evaporation during the greater part of the time. In order to correspond as closely as possible with the basis of figures for earth reservoirs, Table XLIX has been calculated, assuming that the actual reservoir capacity for storage is diminished by 3 feet times the surface area of the reservoir.

In Table XLIX is also given a column showing the quotient arising from dividing the rated reservoir capacity by the surface area. Figs. 49 and 50 show the relation between the cost of reservoir construction per acre-foot output and the output capacity of the reservoir in acre-feet. The curves are drawn for Cases 1, a-c-d-e-f-g-h. On the diagrams are also plotted points representing the relation between the cost of reservoir

construction per acre-foot and the reservoir capacity as given in Schuyler's tables, these points being denoted by black points surrounded by small circles and numbered to correspond to the numbers in the table. In the cases in which surface areas are given (Table XLIX), points are also given denoting the relation between the reservoir output capacity and the cost per acre-foot output. These points are denoted by small crosses. Several points are not plotted on the diagram, as they are far beyond the range, owing to very high cost of construction. It will be noted that the greater part of the natural reservoirs exceed considerably in cost per acre-foot the cost of construction of earthen reservoirs of corresponding size. On the diagram is also given a point marked "average," which indicates the relation between the average size of reservoirs in Table XLVIII as determined by dividing the gross capacity by the number of reservoirs, and the average cost per acre-foot as determined by dividing the total cost by the total number of acre-feet. This point indicates that in round numbers these reservoirs cost 2.5 times as much as corresponding earthen reservoirs in Cases 1,*a-d*, and about 80 per cent more than corresponding reservoirs in Cases 1,*c-e*, and about the same as Case 1*f*.

It is to be noted particularly that in the cases assumed for earth reservoirs no allowance whatever has been made for taking advantage of the natural lay of the land in aiding in obtaining storage capacity. Where an artificial reservoir several square miles in area is to be built, it will undoubtedly be possible in many cases to obtain very material advantage by the use of natural sites, contributing greatly to the reservoir storage capacity. In fact, should the irrigable land lie in such a way that only part of the reservoir could be used for gravity irrigation, it might easily pay to install a pumping plant for taking water from the lower part of the reservoir rather than to construct a reservoir of considerably greater depth. A general study of reservoir construction by means of earthen embankments brings out the importance from a construction standpoint of comparatively shallow reservoirs, thus leading to considerable percentage losses by evaporation. In round numbers, in the great majority of cases considered, earthen reservoirs will lose 20 to 60 per cent of the water which flows into them, whereas

the natural reservoirs referred to will lose but 15 to 30 per cent of their water from this same cause. Where the percentage of evaporation losses is considerable, it is important that the reservoir be made of such a size that there will be an ample supply of water to fill it during the season, for obvious reasons. It would appear that the construction of earthen reservoirs, if the attendant conditions have been carefully studied, should prove a most important aid in the development of the country.

Many of the natural reservoirs have been constructed with masonry dams at an exceedingly high cost per acre-foot of capacity. The type of construction employed is often largely governed by the conditions of service to which the dam will be subjected, such as excessive floods, necessitating the best kind of construction. Even then it is not uncommon for floods of extraordinary violence to do considerable damage to dams. These points must be taken into consideration in allowing a suitable figure for depreciation. An earthen reservoir, on the contrary, in most cases may be constructed where the danger from floods is practically absent, and where, if conditions are at all favorable, sedimentation of the reservoir may be largely avoided by means of proper sand traps in the supply canal.

In some cases, however, earthen reservoirs are so located that it is difficult to afford them complete protection against the danger of floods without incurring great expense. For economic reasons, earth reservoirs are usually constructed of the material near at hand. The proper dimensions of the banks will depend largely on the nature of their composition, and a suitable design calls for the exercise of good engineering judgment. Earth embankments should preferably be constructed with the coarser material near the outer edge, so that whatever water seeps through, the inner side of the embankment will drain away readily, and not saturate the entire embankment, and render it liable to slip. The more impervious material should be arranged in the center, or nearer the inner side. A core wall in the center of an embankment adds a large factor of safety, protecting against gophers, and other burrowing animals, and adding materially to the imperviousness to water, and consequent diminution of both the loss by seepage and risk of failure. Puddle is usually used for such a purpose, though often a concrete wall, two or three feet thick, is employed.

No reservoir is immune from the danger of damage, and unprecedented conditions of rainfall, etc., have in some cases wrought considerable damage to such structures. Failures have occurred in dams and embankments of all descriptions, due either to conditions difficult to foresee, or to faulty construction. In properly designed dams, where the attendant conditions have been thoroughly studied, the danger of failure is exceedingly small. It is probable that a properly constructed masonry dam offers less danger of failure than a well built earth embankment. Of course in reservoirs built entirely in embankment, the greatly increased length of embankment adds to the chance of failure. Experience with the large number of earth reservoirs indicates that when conditions are at all favorable, when the construction is good, and when precautions are taken to prevent the water exceeding the proper depth, this type of construction is reliable, and is of great economic benefit.

CHAPTER XV.

LARGE RESERVOIRS FOR THE STORAGE OF ARTESIAN WATER.

THE conditions governing the supply of water from an artesian well are different in many respects from those governing the supply of river or rain water, and in consequence reservoir construction to retain part of this supply for irrigation requires special consideration of the various features of the case. In the case of artesian wells, the flow of the water may be considered as practically constant. This does not mean that in one year it may not be somewhat different from its value in another year, due to the possible causes enumerated; but for any considerable period, the output of the wells when the water supply is under considerable head may be regarded as uniform, provided that excessive development of wells does not affect the water pressure. The possible effect of this contingency should always be taken into consideration when planning a storage reservoir for artesian wells.

In most places where artesian wells occur, there are practically no natural reservoir sites available, and in order to store water the entire reservoir must be constructed artificially. In many districts wells were originally sunk for a supply of stock water, and the flow from them has in some places formed large, shallow pools totally unsuitable for irrigation purposes, due to the elevation being lower than the surrounding land, the shallow depth also presenting an unduly great surface for evaporation.

The question to be solved by the irrigator is, What capacity, and what size and dimensions, would it pay to make the reservoir for the storage of artesian well-water when the supply comes from a well delivering a given flow? As the entire flow of the well may be obtained at no greater cost than part of the supply, the natural suggestion is to build a reservoir of sufficient capacity to retain the output of the well between irrigation seasons. There are many practical limitations to the size of

reservoirs for wells, since on the one hand evaporation and seepage play a most important part in determining the dimensions of the reservoirs, tending to call for a greater depth of water; and on the other hand, if the reservoir is made exceedingly deep, the additional depth against which the well has to operate may cut down very materially the discharge. This suggests one important point about artesian wells, namely, that the discharge of the well should be subjected to as little hydrostatic pressure as possible. Artesian pressure will raise the water without flow to a certain height above the ground level, known as the static head. If this static head is large, a few feet additional pressure against the well will not have a great effect on the discharge; but should the static head be comparatively small, the additional pressure of a few feet of water will materially affect the output. The pipe supplying water to the reservoir should not be taken over the top of the embankment to let the water fall into the reservoir. Rather take it into the lower part, in order that the maximum pressure operating against the artesian flow may be as small as possible for as long a time as possible. Also in this same connection, an outlet should be provided from the well on to the ground direct, and a valve inserted to cut off the reservoir from this pipe, so that when it is desired to irrigate, the well water will be delivered under a still lower hydrostatic pressure than if it were necessary to overcome the difference in elevation between the ground and the top of the water in the reservoir. At the same time, the reservoir water can be added to the water from the well, and used in irrigation.

In the consideration of the problem of reservoir dimensions for artesian wells, the assumption will be made that during the irrigation period there will be a certain time during which the well supply which will not be used directly on the ground for irrigation, owing to rainfall or other causes, will be stored in the reservoir. In order to simplify the problem, which would otherwise be quite complicated, further assumption will be made that the flow of the well is constant and is not affected by the static pressure due to the water in the reservoir. The problem to be solved, then, is: Under these conditions what size and construction of reservoir will give the cheapest total annual cost of all water used for irrigation, including both the output of the

reservoir and the water from the well which is used directly on the land? Obviously the construction of a reservoir will depend on many considerations, among which are the flow of the well, the annual cost of the well per gallon per minute, the irrigation factor without the use of the reservoir, the season of the year during which irrigation is desired, seepage and evaporation, rainfall, as well as the cost of construction of the reservoir itself. For a consideration of this last item it is first necessary to determine the cost per acre-foot of the well water supplied from the well. The flow of 1 gallon per minute will deliver 1.612 acre-feet per year. In estimating the cost of water furnished by an

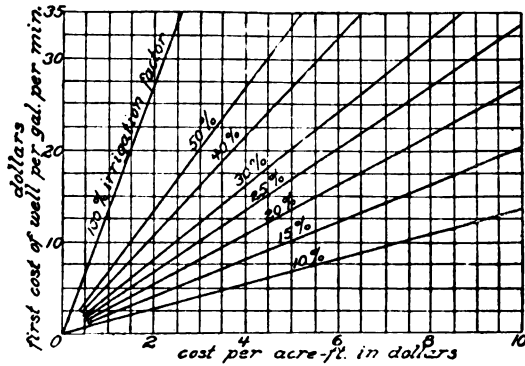

Fig. 51. Cost of Well Water per Acre-foot.

artesian well, the method to be followed is to figure first the cost of the well per gallon per minute, as already outlined, and then to assume twelve per cent per year on the investment to be the cost of obtaining water from the well. Multiplying the cost of well per gallon per minute by 0.12 gives the annual cost per gallon per minute. Dividing the result by 1.612 gives the cost per acre-foot of water. Without storage, well water is used for only a limited portion of the year. The irrigation factor for the well represents the total percentage of time when the well water is in use. The cost per acre-foot just mentioned, refers to the 100 per cent irrigation factor. To ascertain the cost of the well water for any other irrigation factor, divide this cost by the irrigation factor. Fig. 51 and Table L give a tabulation and graphical representation of the result of this method

of calculation. The annual cost of most artesian wells in Texas per acre-foot of water is between 25 cents and \$2. At a 25 per cent irrigation factor this would make the cost of water used without storage between \$1 and \$8 per acre-foot per year.

The use of reservoirs as a storage for water has the additional advantage of utilizing to the utmost the resources of the country and of providing water, even though at a rather high apparent cost, which might otherwise not be supplied.

Let U equal the irrigation factor without a reservoir, then the quantity of water supplied annually by the well would be represented by a depth in the reservoir of $\frac{H - C}{1 - U}$ and the quantity of water actually used would be represented by

$$H - B + (H - C) \frac{U}{1 - U}.$$

In the Appendix, page 227, is given the mathematical method of arriving at the best section of the reservoir. It is to be noted that this method does not provide the most economical reservoir to retain a given supply of water, but it does provide

TABLE L.
THE COST OF WELL WATER.

Well, cost per gal. per min.	\$ Cost per acre-ft. per year for irrigation factor							
	100.	50.	40.	30.	25.	20.	15.	10.
1	.07	.15	.19	.25	.30	.37	.49	.74
2	.15	.30	.37	.50	.60	.74	.99	1.49
3	.22	.45	.56	.74	.89	1.12	1.49	2.23
4	.30	.60	.75	.99	1.19	1.49	1.98	2.98
5	.37	.74	.93	1.24	1.49	1.86	2.48	3.72
6	.45	.89	1.12	1.49	1.79	2.24	2.98	4.47
7	.52	1.04	1.30	1.74	2.08	2.61	3.48	5.21
8	.60	1.19	1.49	1.99	2.38	2.98	3.97	5.96
9	.67	1.34	1.68	2.23	2.68	3.35	4.47	6.70

a reservoir of such proportions that the total acre-feet of water (A) furnished by the well direct to the ground and by the output of the reservoir shall be furnished at a minimum cost, when the cost per acre-foot of water supplied from the well, and also

the corresponding capacity of the well are known. In arriving at a solution of this problem, the cost per acre-foot output of the well is taken as the cost at 100 per cent irrigation factor.

Tables LI to LVIII illustrate the results of these determinations for reservoirs with clearances of 3 feet, and Tables LIX to

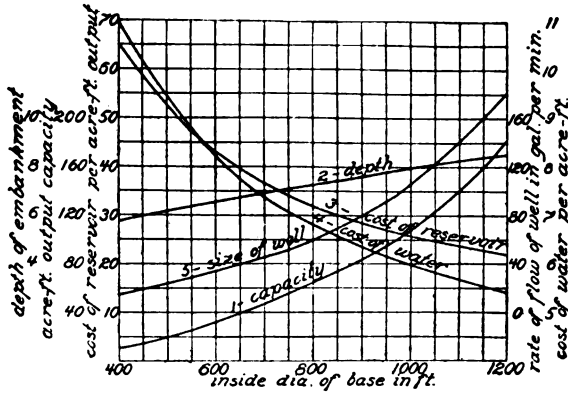

Fig. 52. Economic Well Reservoirs. Case E2.

LXVI illustrate the same thing for reservoirs with 2-ft. clearance. In all cases the cost of the land is taken as \$15 per acre. The cost of water supplied by the well in Cases A, C, E, and G is \$2,

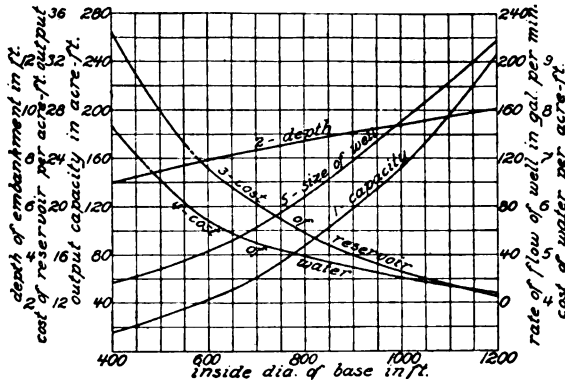

Fig. 53. Economic Well Reservoirs. Case G2.

and in Cases B, D, F, and H is 25 cents per acre-foot. Cases A, B, E, and F are for reservoirs with banks riprapped, and Cases C, D, G, and H are for banks without riprapp. The results in Cases

E2 and G2 are illustrated in curves, Figs. 52 and 53. Curve No. 1 represents the relations existing between the reservoir inside diameter and the total capacity, *A*, in acre-feet. Curve No. 2 represents the relation between the inside diameter and the depth of the embankment. Curve No. 3 represents the relation between the inside diameter and the cost of the reservoir construction per acre-foot of water used, and No. 4 represents the relation between the inside diameter of the reservoir and the annual cost per acre-foot of the water used for irrigation. Curve No. 5 represents the relation between the inside diameter of the reservoir and flow in gallons per minute of the well supplying the same. These tables are all based on an irrigation factor of 25 per cent, annual seepage and evaporation, 6 feet, rainfall, 2 feet, seepage and evaporation during the irrigation season, 3 feet; water supplied from the wells to the reservoir during the irrigation season, 1 foot in depth. Cases 1 and 2 refer to the slopes of the bank, as already outlined.

The reservoir efficiency given in Tables LI to LXVI represents the ratio of the water put into the reservoir to that which is taken out. The well efficiency represents total percentage of well water used for irrigation. Line No. 5 represents the flow in gallons per minute of the well to produce a quantity of water available for irrigation in acre-feet represented by line 6. Line 7 gives the percentage of increase of the well due to storage of the water over the available irrigation water without a reservoir. Line 8 gives the total cost of water for irrigation per acre-foot representing the output of the reservoir and the flow of the well on the ground direct. Line 9 gives the cost of the reservoir per acre-foot of water used for irrigation, as defined.

The assumption made of the 25 per cent irrigation factor would correspond to an irrigation season about four months in length, the total flow of the well being supposed to be used three-fourths of that time. For the irrigation of a crop like cotton in Southern Texas, it is probable that the irrigation factor would be considerably larger. The cost of water without a reservoir in the cases considered would be \$8 per acre-foot for Cases A and C, and \$1 for Cases B and D.

The method of interpretation of the curves given in these figures is similar to that previously given on page 169, and hence will not be repeated. In Case A-1, as given in Table LI

we see that allowing a 3-foot clearance, a well delivering 334 gallons per minute could be used to advantage for supplying 355 acre-feet per year by means of a reservoir costing $\$23.30 \times 355$. The total cost of the water for irrigation with the reservoir, per acre-foot, would be $\$5.51$ as against $\$8$ without the reservoir, and the reservoir would increase the quantity of water actually used, and hence the land which could be irrigated would be increased 163 per cent.

Before undertaking any reservoir construction based on assumptions which have been made here, care should be taken to verify these assumptions and to see that they apply to the particular case considered. It is, of course, evident that large reservoirs like those described will increase materially the available output of the wells, but the same may be done by the use of pumps assisting the artesian flow.

In order to enable one to pass judgment on the relative advantage of reservoirs, or of the use of pumps for increasing the flow of wells, it would be necessary to have, first, an understanding of the law of the flow of water from wells, which may be arrived at as outlined. Generally speaking, pumps may be applied to increase the flow of the wells very materially when the static head above the ground is small, and likewise the head lost in friction in flowing through the pipes. On the other hand, where the static head is large, and lost friction head in the pipes is also large, the pumps cannot be advantageously employed.

ECONOMIC RESERVOIRS FOR ARTESIAN WELLS.

TABLE LI.

CASE A-1.

COST PER ACRE-FOOT WELL OUTPUT—\$.

Diameter of reservoir, ft. . .	400	800	1200	1600	2000	3000	4000
Depth of embankment, ft. . .	6.78	7.93	8.93	9.77	10.58	12.34	13.85
Reservoir efficiency, per cent . .	30.6	42.3	49.6	54.4	58.2	64.7	68.9
Well efficiency, per cent . . .	48.0	56.7	59.7	65.8	68.7	73.5	76.7
Flow of well, gal. per min. . .	13.8	66.3	178	334	570	1,520	3,070
Total quantity annually useful for irrigation, acre-ft. .	10.7	60.5	171	355	632	1,802	3,790
Increase over what well would irrigate without reservoir, per cent	92	127	149	163	175	194	207
Total cost of water irrigation with reservoir, per acre-ft.	Dolls. 14.66	Dolls. 8.40	Dolls. 6.49	Dolls. 5.51	Dolls. 4.90	Dolls. 4.10	Dolls. 3.68
Cost of reservoir per acre-ft. of water used for irrigation.	102.10	46.70	31.10	23.30	18.70	12.80	9.70

TABLE LII.

CASE A-2.

COST PER ACRE-FOOT OF WELL OUTPUT — \$2.

Diameter of reservoir, ft. . .	400	800	1200	1600	2000	3000	4000
Depth of embankment, ft. . .	7.09	8.49	9.66	10.70	11.60	13.78	15.57
Reservoir efficiency, per cent	34.4	46.6	53.8	58.8	62.2	68.7	72.6
Well efficiency, per cent . . .	50.8	60.0	65.3	69.1	71.7	76.5	79.4
Flow of well, gal. per min. . .	15.6	71.5	186	369	631	1,715	3,470
Total quantity annually useful for irrigation, acre-ft. . .	11.8	69.0	196	412	730	2,115	4,450
Increase over what well would irrigate without reservoir, per cent	103	140	162	177	187	206	218
Total cost of water for irrigation with reservoir, per acre-ft.	Dolls. 12.68	Dolls. 7.46	Dolls. 5.80	Dolls. 4.95	Dolls. 4.47	Dolls. 3.77	Dolls. 3.42
Cost of reservoir per acre-ft. of water used for irrigation	84.80	39.50	26.00	19.40	15.70	10.70	8.30

TABLE LIII.

CASE B-1.

COST PER ACRE-FOOT OF WELL OUTPUT — 25 CENTS.

Diameter of reservoir, ft. . .	400	800	1200	1600	2000	3000	4000
Depth of embankment, ft. . .	5.76	6.06	6.35	6.66	6.95	7.60	8.20
Reservoir efficiency, per cent	16.0	20.9	25.2	29.3	32.8	39.4	44.5
Well efficiency, per cent . . .	37.0	40.7	43.9	47.0	49.6	54.6	58.3
Flow of well, gal. per min. . .	11.4	48.1	115	217	355	884	1,720
Total quantity annually useful for irrigation, acre-ft. . .	6.8	31.6	81.5	164	284	780	1,613
Increase over what well would irrigate without reservoir, per cent	48	63	76	88	98	118	134
Total cost of water for irrigation with reservoir, per acre-ft.	Dolls. 13.03	Dolls. 6.51	Dolls. 4.4	Dolls. 3.42	Dolls. 2.78	Dolls. 1.96	Dolls. 1.57
Cost of reservoir per acre-ft. of water used for irrigation	119.00	56.1	35.77	26.9	20.1	12.8	9.5

TABLE LIV.

CASE B-2.

COST PER ACRE-FOOT OF WELL OUTPUT — 25 CENTS.

Diameter of reservoir, ft. . .	400	800	1200	1600	2000	3000	4000
Depth of embankment, ft. . .	5.81	6.21	6.59	6.92	7.29	8.09	8.80
Reservoir efficiency, ft. . . .	16.8	23.2	29.0	32.4	36.5	43.3	48.7
Well efficiency, per cent . . .	37.6	42.4	46.7	49.3	52.4	57.5	61.5
Rate of flow of well, gal. per min.	11.5	49.6	119	226	374	956	1,860
Total quantity annually useful for irrigation, acre-ft. . .	7.0	34.0	89.7	179.7	316	885	1,845
Increase over what well would irrigate without reservoir, per cent	50	70	87	97	110	130	146
Total cost of water for irrigation with reservoir, per acre-ft.	Dolls. 11.14	Dolls. 5.61	Dolls. 3.79	Dolls. 3.09	Dolls. 2.39	Dolls. 1.68	Dolls. 1.35
Cost of reservoir per acre-ft. of water used for irrigation	100.4	46.6	39.4	23.1	16.7	10.5	7.8

TABLE LV.

CASE C-1.

COST PER ACRE-FOOT OF WELL OUTPUT—\$.

Diameter of reservoir, ft. . .	400	800	1200	1600	2000	3000	4000
Depth of embankment, ft. . .	7.41	8.73	9.83	10.76	11.62	13.46	15.15
Reservoir efficiency, per cent	37.6	48.3	54.7	59.0	62.2	67.8	72.8
Well efficiency, per cent . . .	53.2	61.2	66.0	69.2	71.7	75.9	78.8
Flow of well, gal. per min. . .	15.2	73.5	189	372	633	1,670	3,620
Total quantity annually useful for irrigation, acre-ft. . .	13.1	72.8	201.6	416	733	2,045	4,250
Increase over what well would irrigate without reservoir, per cent	112	145	164	177	187	203	217
Total cost of water for irrigation with reservoir, per acre-ft.	Dolls. 9.94	Dolls. 6.32	Dolls. 5.12	Dolls. 4.49	Dolls. 4.11	Dolls. 3.59	Dolls. 3.29
Cost of reservoir per acre-ft. of water used for irrigation	59.5	28.9	19.5	14.9	12.2	8.7	6.8

TABLE LVI.

CASE C-2.

COST PER ACRE-FOOT OF WELL OUTPUT—\$.

Diameter of reservoir, ft. . .	400	800	1200	1600	2000	3000	4000
Depth of embankment, ft. . .	7.84	9.55	10.90	12.07	13.11	15.33	16.92
Reservoir efficiency, per cent	41.5	53.2	59.6	63.8	66.9	72.1	75.0
Well efficiency, per cent . . .	56.1	64.8	69.7	72.7	75.1	79.0	81.2
Flow of well, gal. per min. . .	16.3	81.5	210	423	723	1,928	3,800
Total quantity annually useful for irrigation, acre-ft. . .	14.7	85.4	237	497	876	2,452	4,972
Increase over what well would irrigate without reservoir, per cent	124	160	179	191	201	217	225
Total cost of water for irrigation with reservoir, per acre-ft.	Dolls. 8.10	Dolls. 5.40	Dolls. 4.47	Dolls. 3.98	Dolls. 3.69	Dolls. 3.27	Dolls. 3.03
Cost of reservoir per acre-ft. of water used for irrigation	43.3	21.7	14.8	11.4	9.4	6.7	5.0

TABLE LVII.

CASE D-1.

COST PER ACRE-FOOT OF WELL OUTPUT—25 CENTS.

Diameter of reservoir, ft. . .	400	800	1200	1600	2000	3000	4000
Depth of embankment, ft. . .	6.10	6.50	6.89	7.26	7.60	8.36	9.15
Reservoir efficiency, per cent	21.6	27.3	32.2	36.1	39.4	45.7	50.9
Well efficiency, per cent . . .	41.2	45.4	49.1	52.1	54.5	59.2	63.2
Flow of well, gal. per min. . .	12.2	52.3	126	238	393	988	1,945
Total quantity annually useful for irrigation, acre-ft. . .	8.1	38.4	100	200	346	945	1,980
Increase over what well would irrigate without reservoir, per cent	65	82	96	108	118	137	152
Total cost of water for irrigation with reservoir, per acre-ft.	Dolls. 7.75	Dolls. 4.06	Dolls. 2.33	Dolls. 2.21	Dolls. 1.86	Dolls. 1.38	Dolls. 1.13
Cost of reservoir per acre-ft. of water used for irrigation	67.7	31.9	20.5	14.9	11.8	7.8	5.8

TABLE LVIII.

CASE D-2.

COST PER ACRE-FOOT OF WELL OUTPUT—25 CENTS.

Diameter of reservoir, ft.	400	800	1200	1600	2000	3000	4000
Depth of embankment, ft.	6.11	6.70	7.21	7.68	8.12	9.08	9.92
Reservoir efficiency, per cent	21.7	29.8	35.6	40.1	43.8	50.5	55.1
Well efficiency, per cent	41.3	47.4	51.7	55.4	57.9	62.9	66.3
Flow of well, gal. per min.	42.2	53.5	121	255	425	1,090	2,135
Total quantity annually useful for irrigation, acre-ft.	8.1	40.9	101.3	226.7	396.0	1,105	2,280
Increase over what well would irrigate without reservoir, per cent	65	89	107	120	131	152	166
Total cost of water for irrigation with reservoir, per acre-ft.	Dolls. 6.08	Dolls. 3.20	Dolls. 2.20	Dolls. 1.78	Dolls. 1.49	Dolls. 1.12	Dolls. .94
Cost of reservoir per acre-ft. of water used for irrigation	51.0	23.8	15.7	11.1	8.7	5.7	4.3

TABLE LIX.

CASE E-1.

COST PER ACRE-FOOT OF WELL OUTPUT—\$.

Diameter of reservoir, ft.	400	600	800	1000	1200
Depth of embankment, ft.	5.39	6.06	6.72	7.21	7.72
Reservoir efficiency, per cent	25.8	34.0	40.5	44.5	48.2
Well efficiency, per cent	44.4	50.5	55.4	58.4	61.1
Flow of well, gal. per min.	12.8	32.5	64.0	107.5	166.0
Total quantity annually useful for irrigation, acre-ft.	9.2	26.4	57.1	101.2	163.5
Increase over what well would irrigate without reservoir, per cent	77	102	121	133	145
Total cost of water for irrigation with reservoir, per acre-ft.	Dolls. 12.56	Dolls. 9.25	Dolls. 7.56	Dolls. 6.63	Dolls. 5.95
Cost of reservoir per acre-ft. of water used for irrigation	77.20	40.30	37.30	30.10	25.10

TABLE LX.

CASE E-2.

COST PER ACRE-FOOT OF WELL OUTPUT—\$.

Diameter of reservoir, ft.	400	600	800	1000	1200
Depth of embankment, ft.	5.76	6.55	7.25	7.91	8.50
Reservoir efficiency, per cent	30.6	39.0	44.8	49.4	53.0
Well efficiency, per cent	47.9	54.2	58.7	62.1	64.7
Flow of well, gal. per min.	13.7	35.2	69.2	117.5	182.0
Total quantity annually useful for irrigation, acre-ft.	10.6	30.7	65.5	117.5	190.2
Increase over what well would irrigate without reservoir, per cent	92	117	134	148	159
Total cost of water for irrigation with reservoir, per ft.	Dolls. 10.96	Dolls. 8.20	Dolls. 6.79	Dolls. 5.98	Dolls. 5.40
Cost of reservoir per acre-ft. of water used for irrigation	65.00	42.80	31.90	25.60	21.60

TABLE LXI.

CASE F-1.

COST PER ACRE-FOOT OF WELL OUTPUT—25 CENTS.

Diameter of reservoir, ft.	400	600	800	1000	1200
Depth of embankment, ft.	4.16	4.36	4.56	4.74	5.06
Reservoir efficiency, per cent	3.8	8.3	12.3	15.6	20.9
Well efficiency, per cent	27.9	31.2	33.5	36.7	40.7
Flow of well, gal. per min.	9.8	23.3	44.3	71.0	109.0
Total quantity annually useful for irrigation, acre-ft.	4.44	11.74	24.00	42.10	71.50
Increase over what well would irrigate without reservoir, per cent	11	25	37	47	63
Total cost of water for irrigation with reservoir, per acre-ft.	Dolls. 10.80	Dolls. 7.22	Dolls. 5.44	Dolls. 4.40	Dolls. 3.64
Cost of reservoir per acre-ft. of water used for irrigation	92.20	58.30	42.00	32.70	26.40

TABLE LXII.

CASE F-2.

COST PER ACRE-FOOT OF WELL OUTPUT—25 CENTS.

Diameter of reservoir, ft.	400	600	800	1000	1200
Depth of embankment, ft.	4.31	4.55	4.77	5.00	5.20
Reservoir efficiency, per cent	7.2	12.1	16.2	20.0	23.1
Well efficiency, per cent	30.4	34.0	37.1	40.0	42.3
Flow of well, gal. per min.	10.3	24.8	45.7	74.1	112.0
Total quantity annually useful for irrigation, acre-ft.	5.03	13.35	27.30	47.90	76.30
Increase over what well would irrigate without reservoir, per cent	22	36	49	60	69
Total cost of water for irrigation with reservoir, per acre-ft.	Dolls. 8.98	Dolls. 6.07	Dolls. 4.61	Dolls. 3.74	Dolls. 3.19
Cost of reservoir per acre-ft. of water used for irrigation	75.50	58.20	34.90	27.20	22.40

TABLE LXIII.

CASE G-1.

COST PER ACRE-FOOT OF WELL OUTPUT—\$2.

Diameter of reservoir, ft.	400	600	800	1000	1200
Depth of embankment, ft.	6.27	7.00	7.68	8.27	8.82
Reservoir efficiency, per cent	36.2	42.8	47.9	51.7	54.7
Well efficiency, per cent	52.2	57.2	61.0	63.8	66.0
Flow of well, gal. per min.	14.0	37.5	73.2	123.4	190.0
Total quantity annually useful for irrigation, acre-ft.	12.56	34.70	72.00	126.80	201.60
Increase over what well would irrigate without reservoir, per cent	109	128	143	155	164
Total cost of water for irrigation with reservoir, per acre-ft.	Dolls. 8.65	Dolls. 6.74	Dolls. 5.76	Dolls. 5.15	Dolls. 4.78
Cost of reservoir per acre-ft. of water used for irrigation	45.70	30.40	23.10	18.60	15.10

TABLE LXIV.

CASE G-2.

COST PER ACRE-FOOT OF WELL OUTPUT — \$2.

Diameter of reservoir, ft.	400	600	800	1000	1200
Depth of embankment, ft.	6.96	7.89	8.70	9.37	10.08
Reservoir efficiency, per cent	42.5	49.4	54.1	57.3	60.3
Well efficiency, per cent	57.0	62.0	65.5	68.0	70.3
Flow of well, gal. per min.	16.5	42.3	88.0	150.0	216.0
Total quantity annually useful for irrigation, acre-ft.	15.24	42.30	87.80	153.0	245.0
Increase over what well would irrigate without reservoir, per cent	127	148	162	172	181
Total cost of water for irrigation with reservoir, per acre-ft.	Dolls. 7.67	Dolls. 5.71	Dolls. 4.97	Dolls. 4.52	Dolls. 4.20
Cost of reservoir per acre-ft. of water used for irrigation	34.50	23.20	17.80	14.50	12.40

TABLE LXV.

CASE H-1.

COST PER ACRE-FOOT OF WELL OUTPUT — 25 CENTS.

Diameter of reservoir, ft.	400	600	800	1000	1200
Depth of embankment, ft.	4.68	4.95	5.21	5.45	5.67
Reservoir efficiency, per cent	14.5	19.2	23.8	26.6	29.5
Well efficiency, per cent	35.9	39.4	42.9	45.5	47.1
Flow of well, gal. per min.	11.2	26.5	49.2	80.2	122.0
Total quantity annually useful for irrigation, acre-ft.	6.4	16.9	34.0	58.9	92.5
Increase over what well would irrigate without reservoir, per cent	43	57	71	80	88
Total cost of water for irrigation with reservoir, per acre-ft.	Dolls. 6.48	Dolls. 4.40	Dolls. 3.39	Dolls. 2.78	Dolls. 2.39
Cost of reservoir per acre-ft. of water used for irrigation	53.1	33.60	24.40	19.00	15.60

TABLE LXVI.

CASE H-2.

COST PER ACRE-FOOT OF WELL OUTPUT — \$2.

Diameter of reservoir, ft.	400	600	800	1000	1200
Depth of embankment, ft.	5.09	5.43	5.73	6.01	6.29
Reservoir efficiency, per cent	21.4	26.4	30.2	33.5	36.5
Well efficiency, per cent	41.1	44.8	47.6	50.1	52.3
Flow of well, gal. per min.	12.2	29.1	54.8	89.8	135.0
Total quantity annually useful for irrigation, acre-ft.	8.1	21.0	42.0	72.5	113.8
Increase over what well would irrigate without reservoir, per cent	64	79	91	100	109
Total cost of water for irrigation with reservoir, per acre-ft.	Dolls. 3.78	Dolls. 3.32	Dolls. 2.59	Dolls. 2.15	Dolls. 1.87
Cost of reservoir per acre-ft. of water used for irrigation	38.00	24.30	17.80	13.90	11.50

CHAPTER XVI.

ECONOMICS USES OF RESERVOIRS AND TANKS.

IN case it is desired to irrigate only during the daytime, and not at night, then provided a reservoir is constructed to hold the night supply of the pump, a far smaller pump plant may be installed to perform the same work required of a plant operated only during the daytime. The cost of a reservoir will generally be much less than the cost of doubling the size of the pump plant. The smaller plant will, in general, require more fuel for the delivery of a given quantity of water, owing to the lower efficiency of smaller units, and will also need more labor; but, on the other hand, the fixed expenses of the smaller plant will be much less. In case the plant is used only a comparatively short time during the year, for irrigation, usually the fixed expenses will be far in excess of the operating expenses, and it will pay to put in the smaller plant and reservoir, especially where labor is cheap. To get up steam in plants which run only in the daytime will require an amount of fuel equal to that consumed in from 1 to 2 hours' full-load run.

In plants pumping from wells where a great part of the head consists of the distance the water is lowered in the well, a very large fuel saving may be made by operating a small plant a long time rather than a large plant a shorter time.

Existing plants, where night irrigation is undesirable, may have their capacity greatly increased by the construction of reservoirs to hold the night supply of the pump. The cost of such reservoirs is usually only a small fraction of the cost of the pumping plants which will supply them. It is frequently desirable not to irrigate during the heat of the day, in which event a reservoir is a most useful aid in irrigation.

To illustrate some of the advantages of reservoirs in diminishing the cost of irrigation, some examples in practice will be given where conditions could have been improved. A steam plant, which cost \$3,000, was used to pump from a well. The

plant was operated 10 hours per day. The quantity of water delivered was 2,500 gal. per min. and the head 50 feet. Water stood 2 feet below the ground without flow, and the friction in the well casing and piping was practically the only source of loss of head. If 10 hours' run was sufficient for the needs of the land, then the capacity of the plant could have been reduced to 1040 gal. per min., if run for 24 hours. Under these conditions the lift would be $48 \times \left(\frac{1}{2.4}\right)^2 = 8.3 + 2 = 10.3$ feet.

Assuming that a reservoir is built to hold 14 hours' supply, say that the additional head against which it is necessary to pump is, on an average, 3.7 feet, making a total of 14 feet. Then water horsepower at present = 31.6, and the water horsepower of proposed plant = 3.67.

In the first case, the cost of operation is

\$6.30	per day for fuel
1.00	per day for labor
7.30	per day,

allowing for 2 hours' fuel in getting up steam. The cost of fuel for power for the new plant would be \$1.46 per day at the same efficiency, but from decreased size of plant would be, say,

\$3.00	fuel
2.00	labor
5.00	Daily saving \$2.30.

To retain 1040 gal. per min. for 14 hours is equivalent to 608 gal. per min. for 24 hours, or to 2.7 acre-feet capacity.

As the ground is suitable for reservoir construction, assume that an earth reservoir of 3 acre-feet capacity is built, costing 10 cents per cubic yard. By Fig. 36, Case 1, we can make this 5 feet deep and 208 feet diameter, at a cost of \$220, or 6 feet deep and 177 feet in diameter, costing \$280; and, of course, at considerably less first cost if we adopt the slopes of Case 2. Allowing \$300 for reservoir and land, and \$1000 for the pump plant, makes a saving of \$1700 in the first cost, or \$340 a year, figuring 20 per cent fixed expenses and \$2.30 a day in operating expenses. In addition to a saving of this nature, there would be many obvious advantages from a reservoir, in the better regulation of the

quantity of water needed, and in operating the plant at its highest efficiency. The present plant can have its irrigation efficiency materially improved by the addition of a small reservoir, and can also greatly increase its available limit of irrigation without night irrigation. It could be made to operate more cheaply by running longer hours, and not pumping against such a high head. For example, by operating at about 30 per cent less speed for 40 per cent more time, the same quantity of water could be delivered for about half the total fuel expenditure, provided the efficiency were the same. Practically, the efficiency would diminish, owing to the engine and boiler being operated below capacity, but still considerable fuel saving could be expected over the present method of operation.

If it were desired to have the present plant irrigate twice the area of land without night irrigation, what would it cost to construct a reservoir, and what dimensions should it be given? Let cost = 10 cents per cubic yard. To store 2500 gal. per min. for 12 hours, requires 5.5 acre-feet. In Case 1, a 5-acre-foot reservoir, 5 feet deep, 272 feet in diameter, would cost \$290; 7 feet deep and 208 feet diameter, \$440.

A certain pump plant cost \$1250 for the pump and power station, and \$1400 for a pipe line. The capacity of the pump was 800 gal. per min., and the cost of labor 55 cents per day. The pump operated against a lift of 65 feet plus friction head, and 12 hours per day were sufficient for irrigation. What saving could have been effected if the pump discharged into a reservoir, and operated for 24 hours a day, against the same head? If a plant of half the capacity were installed to operate continuously, the first cost would be materially lessened as indicated below. The present plant operates for 45 days a year, on an average.

Present cost of labor per day	\$0.55
Present cost of fuel per day	5.00
	<u>\$5.55</u>
Annual fuel expense = 45×5.00	\$225
Annual labor expense = 45×0.55	25
Fixed expense, 20 per cent on \$1250	250
Fixed expense, 12 per cent on \$1400	168
Total annual expense	<u>\$668</u>

If a reservoir be installed to hold 12 hours' supply of a plant of half this capacity, it will need to hold 200 gal. per min. for a day, or 0.88 acre-feet. The soil is unsuitable for reservoir construction without lining. As labor is very cheap, assume the reservoir lined with puddle, and the cost of labor and materials is two-thirds of the cost assumed in Case 3 \bar{l} . Then the reservoir will cost, approximately, \$300.

Allowing for increased fuel expense, but also for the gain from constant operation,

Cost of labor per day	\$1.10	
Cost of fuel per day	5.50	
	<u> </u>	\$6.60
Cost of power house		700
Cost of pipe line		900
Annual fuel expense 45×5.5	\$250	
Annual labor expense 45×1.10	50	
Fixed expense, 20 per cent, \$700 for power plant		140
Fixed expense, 12 per cent, \$900 for pipe line		72
Fixed expense, 12 per cent, \$300 for reservoir		36
Total		<u> </u>
	\$668	\$548
	548	
Saving per year	<u> </u>	\$120

APPENDIX A.

TABLE LXVII.

LIST OF RESERVOIR CASES AND ASSUMED DATA.

Cases	Quantities									
	B.	C.	W.	b.	g.	l.	v.	P.	S.	T.
1a . . .	6.00	2.00	4.00	3.00	4.00	.25	5.00	2.00	3.00	2.50
1b . . .	6.0	2.0	4.0	3.0	4.0	2.0	30.0	2.0	3.0	2.5
1c . . .	8.00	4.00	10.00	5.00	4.00	.25	5.00	2.00	3.00	2.50
1d . . .	6.00	2.00	4.00	3.00	4.00	.25	5.00	2.00	3.00	2.50
1e . . .	8.00	4.00	10.00	5.00	4.00	.25	5.00	2.00	3.00	2.50
2a . . .	6.00	2.00	4.00	3.00	4.00	.25	5.00	1.50	2.00	1.75
2b . . .	6.00	2.00	4.00	3.00	4.00	2.00	30.00	1.50	2.00	1.75
1f . . .	6.00	2.00	4.00	3.00	4.00	.25	5.00	2.00	3.00	2.50
1g . . .	6.00	2.00	4.00	3.00	4.00	2.00	30.00	2.00	3.00	2.50
1h . . .	8.00	4.00	10.00	5.00	4.00	.25	5.00	2.00	3.00	2.50
1i . . .	6.00	2.00	4.00	3.00	4.00	2.00	30.00	2.00	3.00	2.50
3k . . .	5.00	2.00	4.00	3.00	4.00	2.00	30.00	1.50	1.50	1.50
3l . . .	1.00	1.00	4.00	1.00	0.00	...	30.00	1.50	1.50	1.50
3m . . .	2.00	2.00	4.00	2.00	0.00	...	30.00	1.50	1.50	1.50
1aa . . .	6.00	2.00	4.00	3.00	4.00	.25	5.00	2.00	3.00	2.50
4u . . .	6.00	2.00	*	3.00	4.00	.25	5.00	2.10	2.61	2.36
A1 . . .	5.0	1.0	4.0	3.0	3.0	2.0	15.0	2.0	3.0	2.5
A2 . . .	5.00	1.00	4.00	3.00	3.00	2.00	15.00	1.50	2.00	1.75
B1 . . .	5.00	1.00	4.00	3.00	3.00	.25	15.00	2.00	3.00	2.50
B2 . . .	5.00	1.00	4.00	3.00	3.00	.25	15.00	1.50	2.00	1.75
C1 . . .	5.0	1.0	4.0	3.0	3.0	2.0	15.0	2.0	3.0	2.5
C2 . . .	5.00	1.00	4.00	3.00	3.00	2.00	15.00	1.50	2.00	1.75
D1 . . .	5.00	1.00	4.00	3.00	3.00	.25	15.00	2.00	3.00	2.50
D2 . . .	5.00	1.00	4.00	3.00	3.00	.25	15.00	1.50	2.00	1.75
E1 . . .	4.00	0.00	4.00	2.00	3.00	2.00	15.00	2.00	3.00	2.50
E2 . . .	4.00	0.00	4.00	2.00	3.00	2.00	15.00	1.50	2.00	1.75
F1 . . .	4.00	0.00	4.00	2.00	3.00	.25	15.00	2.00	3.00	2.50
F2 . . .	4.00	0.00	4.00	2.00	3.00	.25	15.00	1.50	2.00	1.75
G1 . . .	4.00	0.00	4.00	2.00	3.00	2.00	15.00	2.00	3.00	2.50
G2 . . .	4.00	0.00	4.00	2.00	3.00	2.00	15.00	1.50	2.00	1.75
H1 . . .	4.00	0.00	4.00	2.00	3.00	.25	15.00	2.00	3.00	2.50
H2 . . .	4.00	0.00	4.00	2.00	3.00	.25	15.00	1.50	2.00	1.70

$$* W = H + 5 - 2bT = H - 9.13.$$

If $H = 9.13$, the bank would have no crown. This applies strictly to cases of greater values of H .

TABLE LXVII — *Concluded.*

Cases	Quantities										
	c.	m.	n.	p.	9w.	t.	d.	i.	k.	q.	1000a
1 <i>l</i>	6.00	.03	.10	.10	2.00	.07	1.00	5.0	0
1 <i>b</i>	6.00	.03	.10	.10	2.00	.07	1.00	5.0	0
1 <i>c</i>	6.00	.03	.10	.10	2.00	.07	1.00	3.0	0
1 <i>d</i>	6.00	.03	.10	.10	2.00	.07	1.00	5.0	1
1 <i>e</i>	6.00	.03	.10	.10	2.00	.07	1.00	3.0	1
2 <i>a</i>	6.00	.03	.10	.10	2.00	.07	1.00	5.0	0
2' <i>b</i>	6.00	.03	.10	.10	2.00	.07	1.00	5.0	0
1 <i>f</i>	6.00	.10	.25	.12	12.00	2.00	.07	1.00	...	2
1 <i>g</i>	6.00	.10	.25	.12	12.00	2.00	.07	1.00	...	2
1 <i>h</i>	6.00	.10	0.22	0.12	12.00	2.00	.07	1.00	...	2
1 <i>i</i>	6.00	.10	0.20	0.10	0.18	12.00	2.00	.07	1.00	...	2
3 <i>k</i>	5.0020	.10	0.90	2.00	.07	1.00	...	0
3 <i>l</i>	0.15	...	0.18	0
3 <i>m</i>15	...	0.18	0
1 <i>aa</i>	6.00	.03	.10	.10	2.00	.07	1.00	3.0	0
4 <i>a</i>	6.00	.03	.10	.10	2.00	.07	1.00	5.0	0
A1	6.00	.03	.10	.10	2.00	.07	1.00	3.0	0
A2	6.00	.03	.10	.10	2.00	.07	1.00	3.0	0
B1	6.00	.03	.10	.10	2.00	.07	1.00	3.0	0
B2	6.00	.03	.10	.10	2.00	.07	1.00	3.0	0
C1	6.0010	.10	2.00	.07	1.00	...	0
C2	6.0010	.10	2.00	.07	1.00	...	0
D1	6.0010	.10	2.00	.07	1.00	...	0
D2	6.0010	.10	2.00	.07	1.00	...	0
E1	6.00	.03	.10	.10	2.00	.07	1.00	3.0	0
E2	6.00	.03	.10	.10	2.00	.07	1.00	3.0	0
F1	6.00	.03	.10	.10	2.00	.07	1.00	3.0	0
F2	6.00	.03	.10	.10	2.00	.07	1.00	3.0	0
G1	6.0010	.10	2.00	.07	1.00	...	0
G2	6.0010	.10	2.00	.07	1.00	...	0
H1	6.0010	.10	2.00	.07	1.00	...	0
H2	6.0010	.10	2.00	.07	1.00	...	0

$$B = b + g - k.$$

W = width of crown of bank.

$$C = b + g + d - c - k.$$

b = clearance.

g = depth of evaporation and seepage losses during irrigation season.

l = \$ cost per acre-foot of water delivered to reservoir.

v = \$ cost of land per acre.

P = $1 \div$ slope of outside bank.

S = $1 \div$ slope of inside bank.

$$T = \frac{1}{2}(P + S).$$

c = depth in reservoir of annual evaporation and seepage.

m = \$ cost of riprap per sq. ft.

n = \$ cost of embankment construction per cu. yd.

p = per cent annual interest, maintenance and depreciation of reservoir.

$9w$ = cost of puddle per sq. yd.

t = width of riprap.

d = annual rainfall.

i = per cent. interest charges.

k = depth of water applied to reservoir during irrigation season.

q = constant.

a = ground slope.

NOTE. In cases A2, B2, E2 and F2, the width of riprap is taken as $3(H - q) = 3(H - 3)$. This applies in Case 2, when $H \geq 12'$. If $H = 12$ the entire bank would be riprapped. A greater value of H would mean a quantity of riprap in excess of the length of bank.

TABLE LXVIII.
CONE RESERVOIRS.

Side Slopes									
Height	1 ft. vertical to 3 ft. horizontal			1 ft. vertical to 2 ft. horizontal			1 ft. vertical to 1.5 ft. horizontal		
	Diameter	Capacity for preceding 1 ft. of depth	Total capacity for corresponding depth	Diameter	Capacity for preceding 1 ft. of depth	Total capacity for corresponding depth	Diameter	Capacity for preceding 1 ft. of depth	Total capacity for corresponding depth
	Ft.	Acro-ft.	Acro-ft.	Ft.	Acro-ft.	Acro-ft.	Ft.	Acro-ft.	Acro-ft.
1	6	.000	.000	4	.000	.000	3	.000	.000
2	12	.002	.002	8	.001	.001	6	.000	.000
3	18	.004	.006	12	.002	.003	9	.001	.001
4	24	.008	.014	16	.004	.007	12	.002	.003
5	30	.013	.027	20	.006	.013	15	.003	.006
6	36	.020	.047	24	.009	.022	18	.005	.011
7	42	.027	.074	28	.012	.034	21	.007	.018
8	48	.037	.111	32	.016	.050	24	.009	.027
9	54	.047	.158	36	.021	.071	27	.012	.039
10	60	.059	.217	40	.026	.097	30	.015	.054
11	66	.072	.289	44	.032	.129	33	.018	.072
12	72	.086	.375	48	.038	.167	36	.021	.093
13	78	.101	.476	52	.045	.212	39	.025	.118
14	84	.118	.594	56	.052	.264	42	.030	.148
15	90	.136	.730	60	.061	.325	45	.034	.182
16	96	.156	.886	64	.069	.394	48	.039	.221
17	102	.177	1.063	68	.079	.473	51	.044	.265
18	108	.199	1.262	72	.088	.561	54	.050	.315
19	114	.222	1.484	76	.099	.660	57	.055	.370
20	120	.247	1.731	80	.110	.770	60	.062	.432
21	126	.272	2.003	84	.121	.891	63	.068	.500
22	132	.300	2.303	88	.133	1.024	66	.075	.575
23	138	.328	2.631	92	.146	1.170	69	.082	.657
24	144	.358	2.989	96	.159	1.329	72	.089	.746
25	150	.389	3.378	100	.173	1.502	75	.097	.843
26	156	.422	3.800	104	.187	1.689	78	.105	.948
27	162	.455	4.255	108	.202	1.891	81	.114	1.062
28	168	.490	4.745	112	.218	2.109	84	.122	1.184
29	174	.526	5.271	116	.234	2.343	87	.132	1.316
30	180	.564	5.835	120	.251	2.594	90	.141	1.457
31	186	.603	6.438	124	.268	2.862	93	.151	1.608
32	192	.643	7.081	128	.286	3.148	96	.161	1.769
33	198	.685	7.766	132	.305	3.453	99	.171	1.940
34	204	.728	8.494	136	.323	3.776	102	.182	2.122
35	210	.772	9.266	140	.343	4.119	105	.193	2.315
36	216	.817	10.083	144	.363	4.482	108	.204	2.519
37	222	.864	10.947	148	.384	4.866	111	.216	2.735
38	228	.912	11.859	152	.405	5.271	114	.228	2.963
39	234	.961	12.820	156	.427	5.698	117	.240	3.203
40	240	1.011	13.831	160	.450	6.148	120	.253	3.456
41	246	1.064	14.895	164	.473	6.621	123	.266	3.722
42	252	1.116	16.011	168	.496	7.117	126	.279	4.001

TABLE LXVIII — *Continued.*

Side Slopes									
Height	1 ft. vertical to 3 ft. horizontal			1 ft. vertical to 2 ft. horizontal			1 ft. vertical to 1.5 ft. horizontal		
	Diameter	Capacity for preceding 1 ft. of depth	Total capacity for corresponding depth	Diameter	Capacity for preceding 1 ft. of depth	Total capacity for corresponding depth	Diameter	Capacity for preceding 1 ft. of depth	Total capacity for corresponding depth
	Ft.	Ft.	Acre-ft.	Ft.	Acre-ft.	Acre-ft.	Ft.	Acre-ft.	Acre-ft.
43	258	1.170	17.181	172	.521	7.638	129	.293	4.294
44	264	1.226	18.407	176	.545	8.183	132	.307	4.601
45	270	1.283	19.690	180	.570	8.753	135	.321	4.922
46	276	1.342	21.032	184	.597	9.350	138	.335	5.257
47	282	1.400	22.432	188	.623	9.973	141	.350	5.607
48	288	1.462	23.894	192	.650	10.623	144	.366	5.973
49	294	1.525	25.419	196	.678	11.301	147	.381	6.354
50	300	1.590	27.009	200	.707	12.008	150	.397	6.751
51	306	1.655	28.664	204	.736	12.744	153	.413	7.164
52	312	1.720	30.384	208	.764	13.508	156	.430	7.594
53	318	1.787	32.171	212	.794	14.302	159	.447	8.041
54	324	1.856	34.027	216	.825	15.127	162	.463	8.504
55	330	1.925	35.952	220	.856	15.983	165	.481	8.985
56	336	1.996	37.948	224	.887	16.870	168	.498	9.483
57	342	2.070	40.018	228	.920	17.790	171	.517	10.000
58	348	2.140	42.150	232	.952	18.742	174	.536	10.536
59	354	2.220	44.370	236	.986	19.728	177	.555	11.091
60	360	2.300	46.670	240	1.020	20.748	180	.573	11.664
61	366	2.380	49.050	244	1.054	21.802	183	.593	12.257
62	372	2.450	51.500	248	1.089	22.891	186	.613	12.870
63	378	2.530	54.030	252	1.125	24.016	189	.633	13.503
64	384	2.610	56.640	256	1.160	25.176	192	.652	14.155
65	390	2.700	59.340	260	1.198	26.374	195	.674	14.829
66	396	2.780	62.120	264	1.234	27.608	198	.695	15.524
67	402	2.870	64.990	268	1.270	28.878	201	.716	16.240
68	408	2.950	67.940	272	1.313	30.191	204	.738	16.978
69	414	3.040	70.980	276	1.351	31.542	207	.770	17.748
70	420	3.130	74.110	280	1.390	32.932	210	.783	18.531
71	426	3.220	77.330	284	1.432	34.364	213	.806	19.337
72	432	3.310	80.640	288	1.473	35.837	216	.828	20.165
73	438	3.410	84.050	292	1.515	37.352	219	.852	21.017
74	444	3.510	87.560	296	1.556	38.908	222	.877	21.894
75	450	3.600	91.160	300	1.600	40.508	225	.899	22.793
76	456	3.700	94.860	304	1.643	42.151	228	.925	23.718
77	462	3.800	98.660	308	1.708	43.859	231	.949	24.667
78	468	3.900	102.560	312	1.735	45.594	234	.973	25.640
79	474	3.990	106.550	316	1.774	47.368	237	.998	26.638
80	480	4.100	110.650	320	1.820	49.188	240	1.024	27.662
81	486	4.200	114.850	324	1.867	51.055	243	1.050	28.712
82	492	4.310	119.160	328	1.912	52.967	246	1.079	29.791
83	498	4.410	123.570	332	1.960	54.920	249	1.103	30.894
84	504	4.520	128.090	336	2.010	56.930	252	1.130	32.024
85	510	4.630	132.720	340	2.060	58.990	255	1.158	33.182
86	516	4.740	137.460	344	2.100	61.090	258	1.184	34.366

TABLE LXVIII — *Continued.*

Side Slopes									
Height	1 ft. vertical to 3 ft. horizontal			1 ft. vertical to 2 ft. horizontal			1 ft. vertical to 1.5 ft. horizontal		
	Diameter	Capacity for preceding 1 ft. of depth	Total capacity for corresponding depth	Diameter	Capacity for preceding 1 ft. of depth	Total capacity for corresponding depth	Diameter	Capacity for preceding 1 ft. of depth	Total capacity for corresponding depth
	Ft.	Acres-ft.	Acres-ft.	Ft.	Acres-ft.	Acres-ft.	Ft.	Acres-ft.	Acres-ft.
87	522	4.850	142.310	348	2.150	63.240	261	1.212	35.578
88	528	4.960	147.270	352	2.200	65.440	264	1.240	36.818
89	534	5.070	152.340	356	2.250	67.690	267	1.269	38.087
90	540	5.190	157.530	360	2.310	70.000	270	1.298	39.385
91	546	5.300	162.830	364	2.360	72.360	273	1.326	40.711
92	552	5.420	168.250	368	2.410	74.770	276	1.355	42.066
93	558	5.550	173.800	372	2.470	77.240	279	1.388	43.454
94	564	5.670	179.470	376	2.520	79.760	282	1.417	44.871
95	570	5.780	185.250	380	2.570	82.330	285	1.444	46.315
96	576	5.910	191.160	384	2.620	84.950	288	1.477	47.792
97	582	6.020	197.180	388	2.680	87.630	291	1.504	49.296
98	588	6.160	203.340	392	2.740	90.370	294	1.540	50.836
99	594	6.290	209.630	396	2.800	93.170	297	1.572	52.408
100	600	6.420	216.050	400	2.860	96.030	300	1.605	54.013
101	606	6.550	222.600	404	2.910	98.940	303	1.633	55.646
102	612	6.680	229.280	408	2.970	101.910	306	1.670	57.316
103	618	6.810	236.090	412	3.030	104.940	309	1.701	59.017
104	624	6.940	243.030	416	3.080	108.020	312	1.735	60.752
105	630	7.080	250.110	420	3.140	111.160	315	1.769	62.521
106	636	7.220	257.330	424	3.200	114.360	318	1.803	64.324
107	642	7.350	264.680	428	3.270	117.630	321	1.838	66.162
108	648	7.500	272.180	432	3.330	120.960	324	1.874	68.036
109	654	7.630	279.810	436	3.390	124.350	327	1.908	69.944
110	660	7.780	287.590	440	3.450	127.800	330	1.942	71.886
111	666	7.920	295.510	444	3.520	131.320	333	1.979	73.865
112	672	8.050	303.560	448	3.580	134.900	336	2.010	75.875
113	678	8.200	311.760	452	3.650	138.550	339	2.050	77.925
114	684	8.350	320.110	456	3.710	142.260	342	2.090	80.015
115	690	8.500	328.610	460	3.770	146.030	345	2.120	82.135
116	696	8.650	337.260	464	3.840	149.870	348	2.160	84.295
117	702	8.800	346.060	468	3.910	153.780	351	2.200	86.495
118	708	8.950	355.010	472	3.980	157.760	354	2.240	88.735
119	714	9.120	364.130	476	4.050	161.810	357	2.280	91.015
120	720	9.270	373.400	480	4.110	165.920	360	2.310	93.325
121	726	9.420	382.820	484	4.170	170.090	363	2.350	95.675
122	732	9.580	392.400	488	4.250	174.340	366	2.390	98.065
123	738	9.750	402.150	492	4.330	178.670	369	2.430	100.495
124	744	9.900	412.050	496	4.390	183.060	372	2.470	102.965
125	750	10.050	422.100	500	4.470	187.530	375	2.510	105.475
126	756	10.210	432.310	504	4.540	192.070	378	2.550	108.025
127	762	10.370	442.680	508	4.610	196.680	381	2.590	110.615
128	768	10.550	453.230	512	4.680	201.360	384	2.640	113.255
129	774	10.710	463.940	516	4.760	206.120	387	2.680	115.935
130	780	10.870	474.810	520	4.830	210.950	390	2.720	118.655

TABLE XLVIII — *Concluded.*

Side Slopes									
Height	1 ft. vertical to 3 ft. horizontal			1 ft. vertical to 2 ft. horizontal			1 ft. vertical to 1.5 ft. horizontal		
	Diam-eter	Capacity for preceding 1 ft. of depth	Total capacity for corresponding depth	Diam-eter	Capacity for preceding 1 ft. of depth	Total capacity for corresponding depth	Diam-eter	Capacity for preceding 1 ft. of depth	Total capacity for corresponding depth
	Ft.	Acres-ft.	Acres-ft.	Ft.	Acres-ft.	Acres-ft.	Ft.	Acres-ft.	Acres-ft.
131	786	11.030	485.840	524	4.910	215.860	393	2.760	121.415
132	792	11.200	497.040	528	4.990	220.850	396	2.800	124.215
133	798	11.380	508.420	532	5.060	225.910	399	2.840	127.055
134	804	11.540	519.960	536	5.130	231.040	402	2.880	129.935
135	810	11.720	531.680	540	5.210	236.250	405	2.930	132.865
136	816	11.900	543.580	544	5.290	241.540	408	2.970	135.835
137	822	12.070	555.650	548	5.370	246.910	411	3.020	138.855
138	828	12.250	567.900	552	5.450	252.360	414	3.060	141.915
139	834	12.430	580.330	556	5.530	257.890	417	3.110	145.025
140	840	12.610	592.940	560	5.610	263.500	420	3.150	148.175
141	846	12.790	605.730	564	5.690	269.190	423	3.190	151.365
142	852	12.980	618.710	568	5.770	274.960	426	3.240	154.605
143	858	13.160	631.870	572	5.850	280.810	429	3.290	157.895
144	864	13.360	645.230	576	5.940	286.750	432	3.330	161.225
145	870	13.540	658.770	580	6.020	292.770	435	3.380	164.605
146	876	13.730	672.500	584	6.100	298.870	438	3.430	168.035
147	882	13.910	686.410	588	6.180	305.050	441	3.470	171.505
148	888	14.100	700.510	592	6.270	311.320	444	3.520	175.025
149	894	14.270	714.790	596	6.350	317.670	447	3.570	178.595
150	900	14.490	729.280	600	6.450	324.120	450	3.620	182.215
151	906	14.670	743.950	604	6.530	330.650	453	3.670	185.885
152	912	14.870	758.820	608	6.620	337.270	456	3.720	189.605
153	918	15.070	773.890	612	6.700	343.970	459	3.770	193.375
154	924	15.270	789.160	616	6.780	350.750	462	3.820	197.195
155	930	15.460	804.620	620	6.880	357.630	465	3.870	201.065
156	936	15.670	820.280	624	6.970	364.600	468	3.920	204.985
157	942	15.860	836.150	628	7.050	371.650	471	3.970	208.955
158	948	16.080	852.230	632	7.150	378.800	474	4.010	212.965
159	954	16.280	868.510	636	7.240	386.040	477	4.070	217.035
160	960	16.500	885.010	640	7.330	393.370	480	4.120	221.155

TABLE LXIX.
CIRCULAR RESERVOIRS.

Inside slope 1 to 3. Outside slope 1 to 2.

NOTE. The capacity given allows for no clearance.

CASE 1.

Diameter base inside	Depth	Diameter top inside	Capacity	Flow to fill in 24 hr.	Earth in embankment			Diameter outside base 4-ft. crown	Length of side of equivalent capacity of square reservoir		
					3-ft. crown	4-ft. crown	5-ft. crown		Inside base	Inside top	Outside base 4-ft. crown
Ft.	Ft.	Ft.	Acre-ft.	Gal. per min.	Cu. yd.	Cu. yd.	Cu. yd.	Ft.	Ft.	Ft.	Ft.
40	2	52	.077	17.3	102	116	130	68	35.5	47.5	63.5
	3	58	.131	29.7	217	242	267	78		53.5	73.5
	4	64	.198	44.8	390	427	464	88		59.5	83.5
	5	70	.279	63.2	630	680	732	98		65.5	93.5
	6	76	.375	84.8	946	1,016	1,078	108		71.5	103.5
	7	82	.488	110.0	1,346	1,429	1,515	118		77.5	113.5
	8	88	.618	140.0	1,840	1,941	2,050	128		83.5	123.5
	50	2	62	.114	25.7	121	137	154		78	44.3
3		68	.189	42.8	254	282	310	88	62.3	82.3	
4		74	.280	63.5	451	492	534	98	68.3	92.3	
5		80	.387	87.5	721	776	835	108	74.3	102.3	
6		86	.512	116.0	1,072	1,150	1,218	118	80.3	112.3	
7		92	.665	148.0	1,510	1,604	1,699	128	86.3	122.3	
8		98	.817	185.0	2,054	2,165	2,281	138	92.3	132.3	
60		2	72	.157	35.6	140	158	177	88	53.2	
	3	78	.259	58.5	290	322	354	98	71.2		91.2
	4	84	.377	85.1	511	557	604	108	77.2		101.2
	5	90	.514	116.0	811	873	937	118	83.2		111.2
	6	96	.670	151.0	1,198	1,283	1,358	128	89.2		121.2
	7	102	.845	191.0	1,679	1,779	1,882	138	95.2		131.2
	8	108	1.044	236.0	2,270	2,387	2,515	148	101.2		141.2
	70	2	82	.209	47.1	158	179	200	98		62.1
3		88	.339	76.6	327	362	398	108	80.1	100.1	
4		94	.487	110.0	572	622	674	118	86.1	110.1	
5		100	.657	149.0	901	969	1,039	128	92.1	120.1	
6		106	.848	192.0	1,324	1,416	1,498	138	98.1	130.1	
7		112	1.062	240.0	1,847	1,954	2,064	148	104.1	140.1	
8		118	1.300	294.0	2,482	2,611	2,747	158	110.1	150.1	
80		2	92	.266	60.3	177	200	224	108	71.0	
	3	98	.430	97.0	363	402	441	118	89.0		109.0
	4	104	.614	139.0	632	687	753	128	95.0		119.0
	5	110	.819	185.0	991	1,065	1,140	138	101.0		129.0
	6	116	1.050	237.0	1,447	1,549	1,636	148	107.0		139.0
	7	122	1.31	295.0	2,013	2,128	2,248	158	113.0		149.0
	8	128	1.586	359.0	2,697	2,833	2,979	168	119.0		159.0

TABLE LXIX—Continued.

Diameter base inside	Depth	Diameter top inside	Capacity	Flow to fill in 24 hr.	Earth in embankment			Diameter outside base 4-ft. crown	Length of side of equivalent capacity of square reservoir		
					3-ft. crown	4-ft. crown	5-ft. crown		Inside base	Inside top	Outside base 4-ft. crown.
Ft.	Ft.	Ft.	Acre-ft.	Gal. per min.	Cu. yds.	Cu. yds.	Cu. yds.	Ft.	Ft.	Ft.	
90	2	102	.333	75.3	196	221	247	118	79.9	91.9	107.9
	3	108	.531	120.0	400	442	485	128		97.9	117.9
	4	114	.754	170.0	693	747	813	138		103.9	127.9
	5	120	1.000	226.0	1,081	1,161	1,243	148		109.9	137.9
	6	126	1.270	287.0	1,574	1,681	1,776	158		115.9	147.9
	7	132	1.570	355.0	2,179	2,305	2,438	168		121.9	157.9
	8	138	1.901	430.0	2,912	3,060	3,211	178		127.9	167.9
	100	2	112	.405	91.6	214	242	270	128	88.7	100.7
3		118	.643	145.0	437	483	529	138		106.7	126.7
4		124	.907	205.0	752	818	883	148		112.7	136.7
5		130	1.198	271.0	1,172	1,257	1,345	158		118.7	146.7
6		136	1.516	343.0	1,700	1,816	1,916	168		124.7	156.7
7		142	1.864	422.0	2,347	2,481	2,614	178		130.7	166.7
8		148	2.243	508.0	3,125	3,283	3,447	188		136.7	176.7
125		2	137	.619	140.0	260	390	328	153	110.8	122.8
	3	143	.972	220.0	528	583	638	163		128.8	148.8
	4	149	1.356	307.0	904	984	1,058	173		134.8	158.8
	5	155	1.770	401.0	1,397	1,496	1,600	183		140.8	168.8
	6	161	2.221	502.0	2,014	2,148	2,364	193		146.8	178.8
	7	167	2.708	613.0	2,764	2,916	3,070	203		152.8	188.8
	8	173	3.230	730.0	3,662	3,843	4,030	213		158.8	198.8
	150	2	162	.878	198.0	307	342	386	178	133.0	145.0
3		168	1.367	309.0	620	683	747	188		151.0	171.0
4		174	1.891	428.0	1,057	1,144	1,231	198		157.0	181.0
5		180	2.459	556.0	1,623	1,737	1,855	208		163.0	191.0
6		186	3.060	692.0	2,328	2,482	2,613	218		169.0	201.0
7		192	3.710	838.0	3,182	3,356	3,530	228		175.0	211.0
8		198	4.390	993.0	4,200	4,400	4,610	238		181.0	221.0
175		2	187	1.180	267.0	353	395	445	203	155.2	167.2
	3	193	1.830	414.0	712	784	855	213		173.2	193.2
	4	199	2.523	571.0	1,208	1,306	1,405	223		179.2	203.2
	5	205	3.260	737.0	1,848	1,977	2,110	233		185.2	213.2
	6	211	4.035	913.0	2,641	2,815	2,962	243		191.2	223.2
	7	217	4.860	1,099.0	3,700	3,795	3,990	253		197.2	233.2
	8	223	5.740	1,297.0	4,732	4,960	5,190	243		203.2	243.2
	200	2	212	1.528	346.0	400	451	503	228	177.3	189.3
3		218	2.360	535.0	803	884	965	238		195.3	215.3
4		224	3.240	732.0	1,358	1,469	1,581	248		201.3	225.3
5		230	4.170	943.0	2,074	2,216	2,364	258		207.3	235.3
6		236	5.150	1,163.0	2,957	3,150	3,314	268		213.3	245.3
7		242	6.180	1,397.0	4,017	4,230	4,450	278		219.3	255.3
8		248	7.26	1,640.0	5,272	5,520	5,780	288		225.3	265.3
250		2	262	2.360	534.0	493	556	620	278	221.8	233.8
	3	268	3.630	820.0	987	1,084	1,184	288		239.8	259.8
	4	274	4.950	1,218.0	1,660	1,794	1,930	298		245.8	269.8
	5	280	6.250	1,413.0	2,527	2,696	2,873	318		251.8	279.8
	6	286	7.700	1,739.0	3,586	3,815	4,012	328		267.8	289.8
	7	292	9.280	2,098.0	4,850	5,110	5,365	338		273.8	299.8
	8	298	10.840	2,453.0	6,340	6,640	6,940	348		279.8	309.8

TABLE LXIX—Continued.

Diameter base inside	Depth	Diameter top inside	Capacity	Flow to fill in 24 hr.	Earth in embankment			Diameter outside base 4-ft. crown	Length of side of equivalent capacity of square reservoir		
					3-ft. crown	4-ft. crown	5-ft. crown		Inside base	Inside top	Outside base 4-ft. crown.
Ft.	Ft.	Ft.	Acre-ft.	Gal. per min.	Cu. yds.	Cu. yds.	Cu. yds.	Ft.	Ft.	Ft.	Ft.
300	2	312	3.370	762.0	586	661	737	328	266.0	278.0	294.0
	3	318	5.170	1,167.0	1,170	1,285	1,401	338		284.0	304.0
	4	324	7.010	1,586.0	1,963	2,111	2,281	348		290.0	314.0
	5	330	8.940	2,020.0	2,978	3,176	3,383	358		296.0	324.0
	6	336	10.940	2,476.0	4,215	4,480	4,710	368		302.0	334.0
	7	342	13.000	2,941.0	5,690	5,980	6,282	378		308.0	344.0
	8	348	15.150	3,428.0	7,420	7,750	8,110	388		314.0	354.0
	350	2	362	4.570	1,034.0	680	765	853	378	310.4	322.4
3		368	6.970	1,574.0	1,353	1,486	1,620	388		328.4	348.4
4		374	9.450	2,137.0	2,268	2,448	2,629	398		334.4	358.4
5		380	12.010	2,717.0	3,329	3,657	3,992	418		340.4	368.4
6		386	14.650	3,311.0	4,845	5,150	5,410	428		346.4	378.4
7		392	17.380	3,930.0	6,520	6,860	7,200	438		352.4	388.4
8		398	20.200	4,563.0	8,490	8,870	9,270	448		358.4	398.4
400		2	412	5.940	1,342.0	773	870	970	428	354.6	366.6
	3	418	9.040	2,024.0	1,538	1,687	1,837	438		372.6	392.6
	4	424	12.230	2,766.0	2,568	2,772	2,977	448		378.6	402.6
	5	430	15.510	3,507.0	3,879	4,136	4,400	458		384.6	412.6
	6	436	18.900	4,270.0	5,471	5,810	6,110	468		390.6	422.6
	7	442	22.370	5,055.0	7,360	7,730	8,120	478		396.6	432.6
	8	448	25.930	5,862.0	9,560	9,990	10,440	488		402.6	442.6
	450	2	462	7.490	1,692.0	865	975	1,085	478	399.0	411.0
3		468	11.380	2,576.0	1,720	1,888	2,057	488		417.0	437.0
4		474	15.390	3,479.0	2,872	3,098	3,328	498		423.0	447.0
5		480	19.470	4,402.0	4,337	4,615	4,910	508		429.0	457.0
6		486	23.670	5,353.0	6,102	6,480	6,810	518		435.0	467.0
7		492	28.000	6,332.0	8,195	8,610	9,030	528		441.0	477.0
8		498	32.380	7,324.0	10,640	11,100	11,600	538		447.0	487.0
500		2	512	9.250	2,084.0	960	1,079	1,201	528	443.0	455.0
	3	518	14.000	3,165.0	1,904	2,088	2,273	538		461.0	481.0
	4	524	18.900	4,267.0	3,175	3,424	3,677	548		467.0	491.0
	5	530	23.900	5,404.0	4,786	5,100	5,420	558		473.0	501.0
	6	536	29.000	6,556.0	6,735	7,140	7,500	568		479.0	511.0
	7	542	34.270	7,751.0	9,030	9,490	9,950	578		485.0	521.0
	8	548	39.600	8,952.0	11,710	12,220	12,760	588		491.0	531.0
	550	2	562	11.140	2,520.0	1,050	1,184	1,318	578	487.6	499.6
3		568	16.890	3,821.0	2,087	2,288	2,491	588		505.0	525.6
4		574	22.770	5,150.0	3,478	3,750	4,026	598		511.6	535.6
5		580	28.780	6,508.0	5,234	5,580	5,930	608		517.6	545.6
6		586	34.900	7,900.0	7,360	7,820	8,200	618		523.6	555.6
7		590	41.100	9,300.0	9,870	10,380	10,860	628		529.6	565.6
8		596	47.500	10,728.0	12,780	13,330	13,920	638		535.6	575.6
600		2	612	13.230	2,992.0	1,143	1,289	1,435	628	531.8	543.8
	3	618	20.040	4,534.0	2,270	2,489	2,712	638		549.8	569.8
	4	624	27.000	6,102.0	3,780	4,080	4,377	648		555.8	579.8
	5	630	34.100	7,700.0	5,687	6,050	6,435	658		561.8	589.8
	6	636	41.300	9,348.0	7,993	8,480	8,900	668		567.8	599.8
	7	642	48.700	10,994.0	10,697	11,240	11,780	678		573.8	609.8
	8	648	56.100	12,778.0	13,850	14,450	15,110	688		579.8	619.8

TABLE LXX.

CIRCULAR RESERVOIRS.

Inside slope 1 to 2. Outside slope 1 to 1½.

NOTE. The capacity given allows for no clearance.

CASE 2.

Diameter base inside	Depth	Diameter top inside	Capacity	Flow to fill in 24 hr.	Earth in embankment			Diameter base outside 4-ft. crown	Length of side of equivalent capacity of square reservoir		
					3-ft. crown	4-ft. crown	5-ft. crown		Inside base	Inside top	Outside base 4-ft. crown
Ft.	Ft.	Ft.	Acre-ft.	Gal. per min.	Cu. yd.	Cu. yd.	Cu. yd.	Ft.	Ft.	Ft.	Ft.
40	2	48	.070	15.8	76	89	103	62	35.5	43.5	57.5
	3	52	.115	26.0	153	175	198	69		47.5	64.5
	4	56	.168	37.9	263	295	328	76		51.5	71.5
	5	60	.229	51.6	410	452	496	83		55.5	78.5
	6	64	.298	67.3	586	650	706	90		59.5	85.5
	7	68	.376	85.0	827	897	965	97		63.5	92.5
	8	72	.465	105.0	1,106	1,188	1,275	104		67.5	99.5
	50	2	58	.106	23.8	91	107	123		72	44.3
3		62	.170	38.5	182	207	234	79	56.3	73.3	
4		66	.244	55.1	310	346	384	86	60.3	80.3	
5		70	.327	74.0	479	526	576	93	64.3	87.3	
6		74	.421	95.2	691	751	815	100	68.3	94.3	
7		78	.526	119.0	951	1,029	1,107	107	72.3	101.3	
8		82	.641	145.0	1,264	1,356	1,453	114	76.3	108.3	
60		2	68	.148	33.4	106	124	143	82	53.2	
	3	72	.237	53.4	211	240	270	89	65.2		82.2
	4	76	.335	75.8	356	397	440	96	69.2		89.2
	5	80	.445	100.3	547	600	656	103	73.2		96.2
	6	84	.566	128.0	785	853	923	110	77.2		103.2
	7	88	.700	158.0	1,075	1,162	1,248	117	81.2		110.2
	8	92	.846	191.0	1,423	1,524	1,630	124	85.2		117.2
	70	2	78	.198	44.7	121	141	163	92		62.1
3		82	.313	70.7	240	272	306	99	74.1	91.1	
4		86	.440	99.5	403	449	496	106	78.1	98.1	
5		90	.580	131.0	616	675	736	113	82.1	105.1	
6		94	.733	163.0	879	954	1,032	120	86.1	112.1	
7		98	.899	203.0	1,200	1,294	1,388	127	90.1	119.1	
8		102	1.080	244.0	1,582	1,690	1,807	134	94.1	126.1	
80		2	88	.255	57.5	136	159	182	102	71.0	
	3	92	.400	91.0	268	304	341	109	83.0		100.0
	4	96	.560	126.0	450	500	552	116	87.0		107.0
	5	100	.734	166.0	685	749	816	123	91.0		114.0
	6	104	.921	208.0	973	1,055	1,139	130	95.0		121.0
	7	108	1.124	254.0	1,325	1,427	1,527	137	99.0		128.0
	8	112	1.341	313.0	1,741	1,858	1,984	144	103.0		135.0

TABLE LXX—Continued.

Diameter base inside	Depth	Diameter top inside	Capacity	Flow to fill in 24 hr.	Earth in embankment			Diameter base outside 4-ft. crown	Length of side of equivalent capacity of square reservoir		
					3-ft. crown	4-ft. crown	5-ft. crown		Inside base	Inside top	Outside base 4-ft. crown
Ft.	Ft.	Ft.	Acre-ft.	Gal. per min.	Cu. yd.	Cu. yd.	Cu. yd.	Ft.	Ft.	Ft.	
90	2	98	.319	72.0	151	176	202	112	79.9	87.9	101.9
	3	102	.500	113.0	297	336	377	119		91.9	108.9
	4	106	.695	157.0	496	551	608	126		95.9	115.9
	5	110	.906	204.0	752	824	896	133		99.9	122.9
	6	114	1.131	255.0	1,068	1,156	1,249	140		103.9	129.9
	7	118	1.373	310.0	1,530	1,559	1,790	147		107.9	136.9
	8	122	1.632	369.0	1,998	2,026	2,161	154		111.9	143.9
	100	2	108	.391	88.3	166	194	222	122	88.7	96.7
3		112	.608	137.0	326	369	413	129		100.7	117.7
4		116	.843	190.0	533	602	664	136		104.7	124.7
5		120	1.094	247.0	821	898	976	143		108.7	131.7
6		124	1.362	308.0	1,162	1,258	1,355	150		112.7	138.7
7		128	1.648	372.0	1,572	1,691	1,809	157		116.7	145.7
8		132	1.955	441.0	2,055	2,193	2,337	164		120.7	152.7
125		2	133	.601	136.0	204	237	272	147	110.8	118.8
	3	137	.930	210.0	398	449	503	154		122.8	139.8
	4	141	1.278	288.0	659	730	803	161		126.8	146.8
	5	145	1.647	372.0	992	1,082	1,176	168		130.8	153.8
	6	149	2.035	460.0	1,397	1,513	1,626	175		134.8	160.8
	7	153	2.448	553.0	1,883	2,023	2,161	182		138.8	167.8
	8	157	2.890	650.0	2,452	2,613	2,779	189		142.8	174.8
	150	2	158	.855	193.0	242	281	321	172	133.0	141.0
3		162	1.316	297.0	470	530	592	179		145.0	162.0
4		166	1.800	412.0	776	858	943	186		149.0	169.0
5		170	2.310	522.0	1,163	1,278	1,370	193		153.0	176.0
6		174	2.845	643.0	1,634	1,766	1,897	200		157.0	183.0
7		178	3.400	769.0	2,194	2,355	2,513	207		161.0	190.0
8		182	3.990	901.0	2,848	3,032	3,223	214		165.0	197.0
175		2	183	1.157	261.0	280	325	371	197	155.2	163.2
	3	187	1.774	400.0	542	611	682	204		167.2	184.2
	4	191	2.417	546.0	893	987	1,083	211		171.2	191.2
	5	195	3.090	698.0	1,334	1,453	1,576	218		175.2	198.2
	6	199	3.790	856.0	1,869	2,019	2,167	225		179.2	205.2
	7	203	4.510	1,019.0	2,506	2,686	2,863	232		183.2	212.2
	8	207	5.270	1,190.0	3,245	3,450	3,670	239		187.2	219.2
	200	2	208	1.500	339.0	317	369	420	222	177.3	185.3
3		212	2.297	519.0	614	692	771	229		189.3	206.3
4		216	3.120	705.0	1,009	1,114	1,220	236		193.3	213.3
5		220	3.980	900.0	1,505	1,639	1,776	243		197.3	220.3
6		224	4.860	1,098.0	2,105	2,274	2,436	250		201.3	227.3
7		228	5.800	1,306.0	2,814	3,020	3,215	257		205.3	234.3
8		232	6.750	1,523.0	3,640	3,870	4,110	264		209.3	241.3
250		2	258	2.310	521.0	393	456	519	272	221.8	229.8
	3	262	3.550	802.0	758	854	950	279		233.8	250.8
	4	266	4.810	1,085.0	1,241	1,371	1,500	286		237.8	257.8
	5	270	6.100	1,375.0	1,847	2,011	2,176	293		241.8	264.8
	6	274	7.430	1,675.0	2,575	2,779	2,980	300		245.8	271.8
	7	278	8.820	1,988.0	3,440	3,680	3,920	307		249.8	278.8
	8	282	10.220	2,305.0	4,430	4,710	4,990	314		253.8	285.8

TABLE LXX — *Concluded.*

Diameter base inside	Depth	Diameter top inside	Capacity	Flow to fill in 24 hr.	Earth in embankment			Diameter base outside 4-ft. crown	Length of side of equivalent capacity of square reservoir		
					3-ft. crown	4-ft. crown	5-ft. crown		Inside base	Inside top	Outside base 4-ft. crown
Ft.	Ft.	Ft.	Acre-ft.	Gal. per min.	Cu. yd.	Cu. yd.	Cu. yd.	Ft.	Ft.	Ft.	Ft.
300	2	308	3.330	752.0	469	544	618	322	266.0	274.0	288.0
	3	312	5.060	1,142.0	903	1,016	1,129	329		278.0	295.0
	4	316	6.850	1,543.0	1,474	1,627	1,780	336		282.0	302.0
	5	320	8.670	1,955.0	2,190	2,383	2,576	343		286.0	309.0
	6	324	10.540	2,380.0	3,049	3,290	3,520	350		290.0	316.0
	7	328	12.450	2,812.0	4,060	4,350	4,620	357		294.0	323.0
	8	332	14.410	3,257.0	5,220	5,540	5,880	364		298.0	330.0
	350	2	358	4.520	1,021.0	544	631	717	372	310.4	318.4
3		362	6.860	1,550.0	1,046	1,176	1,308	379		322.4	339.4
4		366	9.250	2,086.0	1,707	1,882	2,057	386		326.4	346.4
5		370	11.700	2,641.0	2,530	2,751	2,976	393		330.4	353.4
6		374	14.06	3,178.0	3,520	3,790	4,060	400		334.4	360.4
7		378	16.730	3,781.0	4,680	5,010	5,320	407		338.4	367.4
8		382	19.340	4,368.0	6,020	6,390	6,770	414		342.4	374.4
400		2	408	5.890	1,330.0	620	718	816	422	354.6	362.6
	3	412	8.920	2,014.0	1,190	1,336	1,487	429		366.6	383.6
	4	416	12.000	2,712.0	1,940	2,140	2,338	436		370.6	390.6
	5	420	15.160	3,424.0	2,876	3,120	3,376	443		374.6	397.6
	6	424	18.37	4,150.0	3,990	4,300	4,600	450		378.6	404.6
	7	428	21.620	4,888.0	5,300	5,670	6,020	457		382.6	411.6
	8	432	24.970	5,648.0	6,810	7,220	7,650	464		386.6	418.6
	450	2	458	7.430	1,678.0	696	805	915	472	399.0	407.0
3		462	11.230	2,537.0	1,333	1,500	1,666	479		411.0	428.0
4		466	15.120	3,420.0	2,170	2,395	2,612	486		415.0	435.0
5		470	19.080	4,310.0	2,220	3,490	3,776	493		419.0	442.0
6		474	23.080	5,216.0	4,470	4,800	5,140	500		423.0	449.0
7		478	27.200	6,148.0	5,930	6,330	6,730	507		427.0	456.0
8		482	31.300	7,083.0	7,600	8,060	8,550	514		431.0	463.0
500		2	508	9.170	2,067.0	772	893	1,014	522	443.0	451.0
	3	512	13.840	3,130.0	1,478	1,661	1,845	529		455.0	472.0
	4	516	18.600	4,203.0	2,405	2,652	2,895	536		459.0	479.0
	5	520	23.430	5,300.0	3,560	3,870	4,176	543		463.0	486.0
	6	524	28.360	6,408.0	4,930	5,310	5,680	550		467.0	493.0
	7	528	33.400	7,537.0	6,550	6,990	7,430	557		471.0	500.0
	8	532	38.400	8,685.0	8,390	8,900	9,430	564		475.0	507.0
	550	2	558	11.080	2,500.0	847	981	1,113	572	487.6	495.6
3		562	16.730	3,780.0	1,622	1,822	2,024	579		499.6	516.6
4		566	22.450	5,075.0	2,637	2,908	3,174	586		503.6	523.6
5		570	28.300	6,390.0	3,900	4,240	4,576	593		507.6	530.6
6		574	34.200	7,726.0	5,400	5,820	6,230	600		511.6	537.6
7		578	40.200	9,084.0	7,170	7,660	8,140	607		515.6	544.6
8		582	46.200	10,428.0	9,380	9,740	10,320	614		519.6	551.6
600		2	608	13.150	2,972.0	923	1,067	1,212	622	531.8	539.8
	3	612	19.850	4,493.0	1,766	1,983	2,203	629		543.8	560.8
	4	616	26.640	6,020.0	2,871	3,160	3,450	636		547.8	567.8
	5	620	33.700	7,582.0	4,240	4,610	4,976	643		551.8	574.8
	6	624	40.500	9,154.0	5,880	6,330	6,770	650		555.8	581.8
	7	628	47.600	10,730.0	7,790	8,320	8,840	657		559.8	588.8
	8	632	54.800	12,358.0	9,980	10,570	11,200	664		563.8	595.8

TABLE LXXI.
RESERVOIR CAPACITY.

CASE I.

NOTE. The capacity given allows for no clearance.

Diam-eter,	Depth,	Capacity,	Diam-eter,	Depth,	Capacity,	Diam-eter,	Depth,	Capacity,
Ft.	Ft.	Acre-ft.	Ft.	Ft.	Acre-ft.	Ft.	Ft.	Acre-ft.
800	2	23.4	3,000	6	686.0	7,000	10	6,550.0
	3	35.4		7	802.0		11	7,210.0
	4	47.5		8	920.0		12	7,870.0
	5	59.9		9	1,035.0		2	1,768.0
	6	72.3		10	1,153.0		3	2,660.0
	7	85.1		11	1,270.0		4	3,544.0
	8	98.0		12	1,392.0		5	4,434.0
	9	110.9		2	325.3		6	5,315.0
	10	124.3		3	490.0		7	6,212.0
	11	137.9		4	654.0		8	7,111.0
	12	151.1		5	820.0		9	8,010.0
	1,000	2		36.5	4,000		6	985.0
3		55.0	7	1,150.0		11	9,810.0	
4		73.9	8	1,320.0		12	10,700.0	
5		92.8	9	1,484.0		2	2,316.0	
6		112.0	10	1,653.0		3	3,470.0	
7		131.5	11	1,820.0		4	4,623.0	
8		151.1	12	1,991.0		5	5,792.0	
9		171.0	2	578.0		6	6,950.0	
10		191.1	3	870.0		7	8,122.0	
11		212.0	4	1,160.0		8	9,290.0	
12		232.0	5	1,453.0		9	10,440.0	
1,500		2	81.8	5,000		6	1,745.0	9,000
	3	123.0	7		2,040.0	11	12,820.0	
	4	164.8	8		2,336.0	12	13,970.0	
	5	207.0	9		2,628.0	2	2,920.0	
	6	249.2	10		2,926.0	3	4,390.0	
	7	292.0	11		3,222.0	4	5,855.0	
	8	335.0	12		3,520.0	5	7,320.0	
	9	378.0	2		903.0	6	8,796.0	
	10	417.0	3		1,357.0	7	10,275.0	
	11	465.0	4		1,812.0	8	11,720.0	
	12	508.0	5		2,266.0	9	13,210.0	
	2,000	2	145.0		6,000	6	2,720.0	
3		218.3	7	3,177.0		11	16,160.0	
4		292.0	8	3,640.0		12	17,640.0	
5		366.0	9	4,100.0		2	3,603.0	
6		440.0	10	4,550.0		3	5,415.0	
7		515.0	11	5,025.0		4	7,230.0	
8		590.5	12	5,475.0		5	9,050.0	
9		666.0	2	1,300.0		6	10,860.0	
10		742.0	3	1,951.0		7	12,660.0	
11		820.0	4	2,607.0		8	14,490.0	
12		896.0	5	3,260.0		9	16,290.0	
2,500		2	226.5	6,000		6	3,920.0	10,000
	3	340.6	7		4,580.0	11	19,960.0	
	4	455.0	8		5,230.0	12	21,740.0	
	5	570.0	9		5,900.0			

TABLE LXXII.

TABLE OF COEFFICIENTS TO ASSIST IN CALCULATIONS TO
DETERMINE THE CUBIC YARDS OF EARTH IN
RESERVOIR EMBANKMENTS WITH 4-FOOT
CROWN AND OF VARIOUS DEPTHS.

Cubic yards = $a + bd$. d = inside base diameter.

Depth	Case 1 a	Case 1 b .	Case 2 a	Case 2 b	Case 3 a	Case 3 b
Ft.						
2	32	2.10	19	1.75	16	1.57
3	81	4.02	46	3.23	39	2.97
4	166	6.52	90	5.12	75	4.66
5	296	9.60	155	7.43	127	6.70
6	483	13.30	246	10.13	200	9.09
7	728	17.50	367	13.24	295	11.82
8	1,047	22.40	518	16.80	429	14.90
9	1,450	27.80	769	20.70	570	18.35
10	1,942	33.80	1,022	25.10	752	22.10
11	2,544	40.40	1,325	29.80	972	26.25
12	3,341	47.50	1,683	35.00	1,230	30.75
13	3,963	55.30	2,095	40.50	1,529	35.60
14	5,023	63.60	2,579	46.50	1,875	40.75
15	6,113	72.50	3,127	52.90	2,270	46.30
16	2,710	52.15
17	3,215	58.40
18	3,770	65.00
19	4,385	71.90
20	5,070	79.20
22	6,640	94.75
24	8,500	111.75
26	10,670	130.10
28	13,200	150.00
30	16,080	171.00

TABLE LXXIII.
 DIMENSIONS OF CIRCULAR RESERVOIRS OF MOST
 ECONOMIC SECTION WITH 4-FOOT CROWN.

CASE 1. Clearance = $.6 \left(\frac{1 + \sqrt{d}}{10} \right)$ feet.

Inside base diameter	Depth of embankment	Depth of water	Capacity	Volume earth in embankment	Volume earth per acre-ft.
Ft.	Ft.	Ft.	Acre-ft.	Cu. yd.	Cu. yd.
50	1.68	.66	.033	103	3,120
100	1.99	.79	.149	239	1,605
200	2.42	.97	.718	612	853
300	2.74	1.10	1.820	1,103	607
400	3.02	1.22	3.540	1,705	482
600	3.47	1.40	9.210	3,182	345
800	3.85	1.55	18.100	5,042	279
1,000	4.19	1.69	30.700	7,260	236
1,200	4.49	1.81	47.400	9,776	206
1,400	4.77	1.92	68.500	12,642	185
1,600	5.03	2.03	95.200	15,810	166

Clearance = 3 feet.

1,600	4.225	1.225	56.8	11,650	205.0
2,000	4.225	1.225	88.5	14,520	164.0
3,000	4.225	1.225	199.0	21,680	109.0
4,000	4.225	1.225	354.0	29,800	84.3
6,000	4.225	1.225	795.0	43,200	54.4
8,000	4.225	1.225	1,413.0	57,400	40.6
10,000	4.225	1.225	2,206.0	71,800	32.5

TABLE LXXIV.
DIMENSIONS OF CIRCULAR RESERVOIRS OF MOST ECONOMIC SECTION WITH FOUR-FOOT CROWN.

CASE 2. Clearance = $.6 \left(\frac{1 + \sqrt{d}}{10} \right)$ feet.

Inside base diameter	Depth of embankment	Depth of water	Capacity	Volume earth in embankment	Volume earth per acre-ft.
Ft.	Ft.	Ft.	Acre-ft.	Cu. yd.	Cu. yd.
50	1.74	.72	.034	86.4	2,540
100	2.05	.85	.153	200.0	1,265
200	2.48	1.03	.755	510.0	675
300	2.81	1.17	1.920	912.0	475
400	3.08	1.28	3.730	1,304.0	374
600	3.53	1.46	9.560	2,577.0	270
800	3.93	1.63	18.950	4,071.0	215
1,000	4.26	1.76	32.000	5,785.0	181
1,200	4.57	1.89	49.300	7,784.0	158
1,400	4.85	2.00	71.300	10,024.0	141
1,600	5.11	2.11	97.900	12,494.0	128

Clearance = 3 feet.

1,600	4.30	1.30	60.2	9,380	155.7
2,000	4.30	1.30	94.0	11,690	124.4
3,000	4.30	1.30	212.0	17,450	82.3
4,000	4.30	1.30	376.0	23,200	61.7
6,000	4.30	1.30	845.0	34,750	41.1
8,000	4.30	1.30	1,501.0	46,300	30.9
10,000	4.30	1.30	2,345.0	57,800	24.6

APPENDIX B.

CIRCULAR EMBANKMENTS.

$$\begin{aligned} \text{VOLUME of embankment} &= 2 \pi \left(r + HS + \frac{W}{2} \right) H (W + HS) \\ &\quad - 2 \pi \left[r + HS + W + H \left(\frac{P + S}{3} \right) \right] H^2 \left(\frac{S - P}{2} \right) \\ &= \text{approximately, } 2 \pi \left(r + HS + \frac{W}{2} \right) \left[W + H \left(\frac{S + P}{2} \right) \right] H. \end{aligned}$$

$$\text{When } P = S = T, \text{ Volume} = 2 \pi \left(r + HT + \frac{W}{2} \right) (W + HT) H.$$

$$\text{Volume of water} = \frac{\pi}{3S} (r_1^3 - r^3) = (\text{approximately}) \pi \left(r + \frac{hS}{2} \right)^2 h \text{ cu. ft.}$$

Where h = depth of water = $H - b$.

Formulae may be deduced for the economic design of large reservoirs under any predetermined conditions where the land has a given slope. In an individual case, it may be easier to use the cut-and-try method. For example, assume the reservoir diameter. Calculate the corresponding depth for the given capacity output, and to this add the seepage and evaporation losses during the irrigation season less the water supplied to the reservoir in that period = $g - k$, and to that add the clearance. Then the depth being determined, calculate the volume and cost of embankment, cost of lining, cost of land, and cost of riprap. Figure the annual cost and the total fixed charges, cost of lost water, and hence the storage charges on the water. Then assume new diameters and repeat calculations until the minimum cost is reached.

In the figures to follow, the cost of clearing and grubbing, if necessary, must be included in the cost of land, but in many places where labor is very cheap, sufficient wood may be obtained

to help pay for costs of this nature. No expense is figured for removing surface soil under embankments, nor for trenching if necessary, for a puddle core. Such cost should add to the term F , to follow a quantity $2 \pi p Z$, where Z = the additional cost of all such work per foot length of embankment.

Economic Design of Large Reservoirs on Level Ground.

The following figures will apply approximately to large reservoirs: *

$$\text{Cost of embankment} = (W + TH) \frac{2 \pi r H n}{27}$$

$$\text{Cost of riprap} = 2 \pi r S m (H - q).$$

$$\text{Cost of land} = \frac{\pi r^2 v}{43560}.$$

The cost of reservoir will be the sum of these three quantities.

Annual fixed charges on reservoir

$$= 2 \pi r p \left[(W + TH) \frac{H n}{27} + S m (H - q) \right] + \frac{\pi r^2 v i}{43560} \quad (1)$$

Annual cost of water furnished to reservoir

$$= (H - C) \frac{\pi r^2 l}{43560} \quad \dots \dots \dots (2)$$

Annual water output from reservoir in acre-feet

$$= A = (H - B) \frac{\pi r^2}{43560} \quad \dots \dots \dots (3)$$

Hence
$$H = \frac{13860A}{r^2} + B \quad \dots \dots \dots (4)$$

Total annual cost = D = Fixed charges + cost of water furnished to reservoir = (1) + (2).

* These symbols are given on page 204.

Substituting the value of H found in equation (4), in the expression for D , differentiating the same with respect to r , and equating the result to zero, we derive an equation with A and r as variables, which gives the radius of the reservoir constructed according to the principles laid down, i.e., for a minimum annual cost for a given output capacity, A .

Omitting mathematical details, the following results are obtained:

$$A = \left[\sqrt{4 FI + G^2 + 4 IJr} - G \right] \frac{r^2}{2I} \dots \dots \dots (5)$$

$$E = \frac{D}{A} = \frac{rF}{A} + \frac{G}{r} + \frac{IA}{3r^3} + \frac{Jr^2}{2A} + l = \text{Cost per acre-foot output.} \quad (6)$$

Where $F, G, I,$ and J are constants having the following values:

$$F = \frac{2 \pi pn}{27} (WB + B^2 T) + Smp (B - q) 2 \pi$$

$$= .2325 B (W + BT) pn + 6.283 mp (B - q) S:$$

$$G = 87120 p \left(\frac{2 TBn}{27} + \frac{Wn}{27} + Sm \right):$$

$$I = \frac{(43560)^2}{4.5 \pi} pnT = 134,300,000 pnT:$$

$$J = \frac{1}{6930} [ri + (B - C)l].$$

In equation (6), the first three terms relate to fixed charges on the cost of the reservoir construction; the term containing J relates to the cost of lost water and interest on land investment, and the last term, l , is the cost per acre-foot of the water supplied.

Hence the cost of the reservoir construction per acre-foot output

$$= \frac{1}{p} \left[\frac{rF}{A} + \frac{G}{r} + \frac{IA}{3r^3} \right].$$

Then the following are values of the constants in four of the cases considered:

	Case			
	1a	2a	1b	2b.
F3218	.2406	.3218	.2406
G	1879	1329	1879	1329
I	3,355,000	2,350,000	3,355,000	2,350,000
J000195	.000195	.00145	.00145
4FI+G ²	7,850,000	4,030,000	7,850,000	4,030,000
4IJ	2620	1835	19,560	13,700

Let $R = \frac{r}{100} .$

Then in case 1a

$$A = \frac{R^2}{671} [\sqrt{7,850,000 + 262,000 R} - 1879]:$$

$$E = 32.18 \frac{R}{A} + \frac{18.79}{R} + \frac{1.118A}{R^3} + \frac{0.975 R^2}{A} + 0.25.$$

Economic Design of Large Reservoirs on Sloping Ground.

Let the slope of the ground = *a*,

Let the mean height of the embankment = *H*;

Then the cost of the embankment

$$= (W + TH) \frac{2 \pi r H n}{27} + \frac{\pi r^3 a^2 T n}{27} .$$

Annual fixed charges on reservoir

$$= 2 \pi r p \left[(W + TH) \frac{H n}{27} + \frac{r^3 a^2 T n}{54} + Sm(H - q) \right] + \frac{\pi r^2 v i}{43560} . \quad (7)$$

Similarly the equation corresponding to (5) is

$$A = \left[\sqrt{4FI + G^2 + 4IJr + 4IKr^3} - G \right] \frac{r^2}{2I} . . \quad (8)$$

and

$$E = \frac{rF}{A} + \frac{G}{r} + \frac{IA}{3r^3} + \frac{Kr^3}{3A} + \frac{Jr^2}{2A} + l \quad (9)$$

where F, G, I, J have the same values as in the previous case,

and
$$K = \frac{\pi a^2 n p T}{9} = .349 a^2 n p T.$$

It is to be noted that the equations found in this case apply strictly, only when the lowest depth of embankment is somewhat in excess of the clearance; also that while the surface for evaporation will continually diminish when the higher part of the reservoir starts to go dry. Still the fact that part of the water is spread out in a thin sheet and hence subject to more rapid evaporation will be assumed to compensate for the diminished surface.

Economic Designs of Large Reservoirs on Sloping Ground, for Fixed Belt of Riprap, t Feet in Width.

The equation corresponding to (7) is annual fixed charges on the reservoir

$$= 2 \pi r p \left[(W + TH) \frac{Hn}{27} + \frac{r^2 a^2 T n}{54} + mt \right] + \frac{\pi r^2 v}{43560} \quad \cdot \cdot \quad (7a)$$

Equations (8) and (9) still hold where I, J and K have the same values as above, but

$$F = .2325 pn (WB + B^2 T) + 2 t m p \pi,$$

and
$$G = 3228 (W + 2 TB) p n:$$

$$I = 134,300,000 p n T:$$

$$J = \frac{1}{6930} [v i + (B - C) l]:$$

$$K = .349 a^2 n p T.$$

Lined Reservoirs Constructed on Sloping Ground, with Fixed Width of Riprap.

The effect of a lining is to increase the cost of land so much an acre, and all equations given above will still be applicable, with the exception that the term for J becomes

$$J = \frac{1}{6930} (v i + (B - C) l + 43560 w p),$$

where w = cost of lining per square foot.

The arithmetical part of the calculations may be greatly simplified in the following manner. First calculate F, G, I, J, K for any given case. Then let

$$a = \frac{G^2 + 4 FI}{1,000,000} :$$

$$b = \frac{4 IJ}{10,000} :$$

$$c = \frac{4 IK}{100} :$$

$$d = \frac{G}{1000} :$$

$$e = \frac{10,000,000}{2 I} : R = \frac{r}{100} .$$

Then, $\frac{A}{R^2} = \sqrt{(a + bR + cR^2 - d)e}.$

Make the following form:

	R
	a
	bR
	cR ²
	Sum
Square root of Sum	
	d
	Difference
Diff. × e = $\frac{A}{R^2}$	
	$\frac{A}{R}$
	A
	$\frac{A}{R^3}$

$$100 \frac{RF}{A} = ? \frac{R}{A} \dots\dots\dots$$

$$\frac{G}{100 R} = \frac{10 d}{R} \dots\dots\dots$$

$$\frac{IA}{10^6 R^3 \times 3} = ? \frac{A}{R^3} \dots\dots\dots$$

$$\frac{KR^3 \times 10^6}{3 A} = ? \frac{R^3}{A} \dots\dots\dots$$

s = Sum.....

$$\frac{JR^2 \times 10^4}{2 A} = ? \frac{R}{A} \dots\dots\dots$$

l.....

Sum = cost per acre-foot output

$$H = 1.386 \frac{A}{R^2} + B = \dots\dots\dots$$

$$\text{Efficiency} = \frac{H - B}{H - C} = \dots\dots\dots$$

$$\text{Cost per acre-foot capacity}^* = \frac{s}{p} \dots\dots\dots$$

If lined, cost per acre-foot capacity

$$= \frac{JR^2 \times 10^4}{2 A} \times \frac{43560 w}{43560 wp + vi + (B - C) l} + \frac{s}{p} \cdot$$

It will be easier to start with *r* and find the corresponding value of *A* than to endeavor to solve equation (8) for *r* when *A* is given, though the former is a cut-and-try method.

Economic Design of Large Lined Reservoirs of a Given Capacity not Riprapped, Neglecting the Value of the Water Lost by Evaporation.

Here equation (8) still holds,

but $F = .2325 pnB (W + BT):$

$$G = 3228 pn (W + 2 TB):$$

$$I = 134,300,000 pnT:$$

* Unless the bottom is lined.

$$J = \frac{1}{6930} (vi + 43,560 wp):$$

$$K = .349 a^2 npT:$$

and
$$E = \frac{rF}{A} + \frac{G}{r} + \frac{IA}{3r^3} + \frac{Jr^2}{2A} + \frac{Kr^3}{3A} + l \dots \dots (e)$$

If the reservoir is to be built for the cheapest cost per acre-foot for a given capacity, then

$$F = .2325 nB (W + BT):$$

$$G = 3238 n(W + 2 BT):$$

$$I = 134,300,000 nT:$$

$$J = \frac{v + 43560w}{6930}:$$

$$K = .349 a^2 nT:$$

and cost per acre-foot reservoir capacity

$$= \frac{rF}{A} + \frac{G}{r} + \frac{IA}{3r^3} + \frac{Jr^2}{2A} + \frac{Kr^3}{3A}.$$

If in the above the actual capacity alone be considered without reference to losses of water, then in place of B use b .

If the reservoir be of small diameter these figures will not hold, but approximate results may be figured by letting r be the radius of the center of the embankment, and figuring the cost per acre-foot and acre-feet capacity. Then obtain a correction factor by taking ratio of real capacity to figured capacity, as follows:

$$\text{ratio} = \left(\frac{2r - W - T(H + b)}{2r} \right)^2.$$

To obtain the true cost per acre-foot, divide the first cost per acre-foot by this ratio. To obtain true capacity, multiply first capacity by this ratio.

To be accurate this correction factor should be applied to all cases of large reservoirs previously considered.

The cut-and-try method will usually be simpler and more accurate than this method for any individual case. To apply

this, assume various depths of water in reservoir, and from the table or curves figure various diameters. Then, allowing for clearance, figure from tables the volume and cost of embankment. Also calculate cost of lining. As the reservoir increases in depth, as a rule the cost of embankment will increase, and the cost of land and lining decrease. When the sum of all three costs is a minimum for a given capacity, the reservoir will be cheapest.

If the lining be carried up to the top of the bank on the inside, then

$$\text{Cost of earthwork} = \frac{2 \pi}{27} n \left(r + \frac{W}{2} + HT \right) :$$

$$\text{Cost of land} = \frac{v}{43,560} \pi (r + W + 2 TH)^2 :$$

$$\text{Cost of lining} = w\pi \left[r^2 + 2H \left(r + \frac{TH}{2} \right) \sqrt{1 + T^2} \right] :$$

$$\text{Capacity} = \frac{(H - b)}{43,560} \pi \left[r + \frac{T(H - b)}{2} \right]^2 \text{acre-feet.}$$

Economic Design of Reservoirs on Level Ground for the Storage of Artesian Well Water.

U = Irrigation Factor of well without reservoir.

Acre-feet output of well

$$= \frac{\pi r^2}{43,560} \left(\frac{H - C}{1 - U} \right) = r^2 (xH - L) (10)$$

Acre-feet used in Irrigation

$$= \frac{\pi r^2}{43,560} \left[H - B + \frac{U}{1 - U} (H - C) \right] = (xH - z) r^2 = A. (11)$$

Whence,

$$D = 2 \pi pr \left[(W + TH) \frac{Hn}{27} + Sm (H - q) \right] + r^2 \left[\frac{vi}{13,860} + (xH - L) l \right].$$

By (11). $H = \frac{A}{r^2 x} + \frac{z}{x} (12)$

Hence,
$$D = 2 \pi pr \left(\frac{Wnz}{27x} + \frac{z^2 Tn}{27x^2} + Sm \frac{z}{x} - qSm \right) + \frac{2 \pi p A}{x} \frac{1}{r} \left(\frac{2 znT}{27x} + \frac{Wn}{27} + Sm \right) + \frac{A^2}{r^2} \frac{2 \pi npT}{27x^2} + r^2 \left[\frac{vi}{13,860} + (z - L) l \right] + lA \dots \dots \dots (13)$$

Let
$$F = \frac{2 \pi p}{x} \left(\frac{nz^2 T}{27x} + \frac{nWz}{27} + Smz - xqSm \right);$$

$$G = \frac{2 \pi p}{x} \left(\frac{2 nzT}{27x} + \frac{nW}{27} + Sm \right);$$

$$I = \frac{6 \pi pnT}{27x^2};$$

$$J = 2 \left[\frac{vi}{13,860} + (z - L) l \right].$$

Then equation (13) becomes

$$D = Fr + \frac{GA}{r} + \frac{IA^2}{3r^2} + \frac{Jr^2}{2} + lA \dots \dots (14)$$

Differentiate with respect to r , and equate result to zero

$$F - \frac{GA}{r^2} - \frac{IA^2}{r^3} + Jr = 0:$$

Hence,
$$A = \frac{r^2}{2I} \left[\sqrt{4IF + G^2 + 4IJr} - G \right] \dots \dots (15)$$

and
$$E = \frac{Fr}{A} + \frac{G}{r} + \frac{IA}{3r^2} + \frac{Jr^2}{2A} + l.$$

In the above formulæ

$$x = \frac{1}{13,860 (1 - U)}; \quad L = Cx; \quad \frac{z}{x} = B (1 - U) + CU.$$

Cox's Formula.

$$H = \left(\frac{4V^2 + 5V - 2}{1200} \right) \frac{L}{d};$$

where H = friction head in feet, d = diameter of pipe in inches, L = length of pipe in feet, V = velocity of water in feet per second.

INDEX.

- Acre feet**, 11.
Conversion table, 17.
- Acre inch**, 11.
Conversion table, 18.
- Air** — entrained in water, 137.
Lift, 115, 116.
- Altitude**, — effect on evaporation, 33.
- Application**, — cost of water, 37, 39.
- Arid zone of the U. S.**, 1, 2.
- Artesian wells**.
Cost, 190.
Definition, 86.
Reservoirs for, 187 to 198, 227, 228.
Flow increase by pumping, 92.
Static head of, 188.
- Artesian well water cost**, 189, 190.
- Automatic cutout for pump**, 134, 135.
- Basin irrigation**, 20.
- Bed irrigation**, 20, 22.
- Boiler pumps**, cost of, 118.
- Boiler setting**, cost of, 118.
- Boilers** — Steam, cost of, 117.
- Cabbage irrigated and non-irrigated**, 9.
- Canal**, 55, 56.
- Canal linings**, 55, 56.
- Canals**, method of laying out, 56, 61.
- Canals as reservoirs**, 48, 49.
Velocity of water in, 56.
- Capacity of earth reservoirs** — 205 to 215.
Calculation, 156 to 162, 219.
Tables, 205 to 215.
- Centrifugal pumps**, 115, 116.
Capacity of, 119.
Cost of, 119.
- Charging for irrigation**, — methods of, 141 to 146.
- Chezy Formula**, 60.
- Cippoletti Weir**, 67, 68, 69.
- Clearance of reservoirs**, 154.
- Coal tar reservoir lining**, 78.
- Concrete cores for dams**, 73.
Dam, 71.
Lining, cost of, 78.
Reinforce pipe, 60.
- Conduits for water**, 55, 56, 57.
- Cone reservoirs capacity**, 205 to 208.
- Contour check irrigation**, 21, 22.
- Contour ditch irrigation**, 20.
- Core for dams**, 73.
- Core wall-puddle**, 185.
- Cost of irrigation**, 617.
- Crib dams**, 73.
- Crop formation**, moisture for, 4.
- Crop returns and values**, 37.
- Crops**, value of, 9.
- Cubic feet conversion table**, 18.
- Cubic feet per sec. per day conversion table**, 19.
- Cultivation**, deep, advantages of, 27.
Effect on evaporation, 26, 30.
Importance of, 5.
Uselessness of Poor, 30.
- Culverts**, 59.
- Current meter**, 70.
- Dams**, construction of, 70.
Concrete cores for, 53.
Curved, 72.
Earth, 74.
Failure of, 72.
Kinds of, 71.
Timber crib, 73.
Wooden, 73.
Rock fill, 73.
- Deep well pumps**, 115.
- Depth of irrigation**, 15, 16, 17, 35, 36, 37.
Annual, 11, 12.
Depth per irrigation, 12.
- Design of irrigation plants**, 12.
Pumping systems, 40.
- Ditches**, construction of, 65.
Flow in, 65, 66, 67.
- Diversion of water**, Procedure, 42.
- Division box**, 65.
- Drainage**, importance of, 6.
- Drops**, 56, 57.
- Droughts**, effect on plants, 4.
- Duty of water**, 11, 15, 16, 17, 34, 35, 36, 37, 39, 172.
At Bakersfield, 138.
- Earth dams**, 74.
- Earth embankments for carrying water**, 58.
- Earth reservoirs**, Calculation, 156.
Capacity, 157 to 162.

- Earth tanks**, construction, 74, 75.
 Economy in design, 153.
 Importance of, 153.
 Section of, 153.
- Earthwork, cost of, 76.
- Economy in use of water, 6.
- Efficiency of reservoirs, 184, 185.
- Embankments, reservoir**, calculation, 156, 219.
 Construction, 74, 75, 180, 185.
 Curves of, 159, 160, 163.
 Minimum volume of, 161, 217, 218.
 Section of, 179, 180.
 Volumes of earth in, 209 to 216.
- Engines, gasoline**, cost of, 117.
 Steam, cost of, 117.
 Steam, efficiency of, 117.
- Evaporation, alkali soil**, 26.
 Annual losses, 149.
 Capillarity effect, 26.
 Color effect on, 26.
 Cultivation effect on, 26, 30.
 Deep furrows effect on, 27, 31.
 Definition of, 23.
 Efficiency, effect on, 23.
 Humidity, effect on, 24.
 Moist soils vs. water surfaces, 29.
 Mulches, effect on, 26, 31.
 Soil, 5, 30.
 Soil moisture, 4.
 Sub-irrigation, effect on, 27, 32.
 Temperature, effect on, 24.
 Transpiration, effect on, 35.
 Water and earth surfaces, 25.
 Water surfaces, altitude effect on, 33.
 Water surfaces, temperature, effect on, 29.
 Wind, effect on, 24, 29.
- Flooding, irrigation by, 20.
- Flow** in ditches, 65, 66, 67.
 in porous media, 52, 53.
- Flumes**, 57, 58.
 Rating, 69.
 Velocity in, 58.
- Free moisture in soils, 3.
- Frequency of irrigation, 12, 35, 36, 37.
- Friction in pipe-tables, 108 to 112.
- Fuel consumption, pump plant, 122.
- Fuel, Texas, in, 123.
- Furrow**, deep, effect on evaporation, 27, 31.
 Irrigation, 20, 21, 22.
- Gallons, conversion table, 18.
- Gallons per min. per day conversion table, 19.
- Gasoline engines**, cost of, 117.
 Plants, fuel consumption, 122.
 Pump plants, cost of Texas, 121.
- Gate**, head, 62, 63.
 Waste, 64.
 Sluice, 64.
- Head**, Losses in piping entrance and discharge, 107, 112.
 Velocity, 107.
- Heat, methods of transference, 25.
- Heaters, cost of, 118.
- Hose irrigation, 20.
- Humid zone of the U. S., 1, 2.
- Humidity, evaporation, effect on, 24.
- Hydraulic ram, 115, 117.
- Hygroscopic, moisture in soils, 3.
- Inch**, miners, 70.
- Inverted siphon, 57, 59.
- Irrigation**, charges for, 141 to 146.
 Bakersfield, 128, 129.
 Cost of, 6, 7, 39, 151.
 Cost of at Bakersfield, 140.
 Definition, 3.
 Depth, 10, 11, 12, 15, 16, 17, 35, 36, 37.
 Desirable water for, 9.
 Economic limit of, 147 to 152.
 Excessive, 10.
 Expense of, 9.
- Irrigation factor**, Artesian well, 149, 189, 190, 192.
 At Bakersfield, 140.
 Definition, 13.
 Effect on cost, 124.
 in Texas, 36.
- Irrigation**, Frequency of, 10.
 Limit of in Arid America, 147.
 Meadow, 7.
 Methods, 20.
 Need of, 2.
 Plant design, 125, 126, 127.
 Practice, 34, 35, 36, 37, 39.
 Truck, 7.
 Value of, 2, 6, 7, 8, 38, 40, 41.
 Value of, comparative results, 8, 9.
 Value of — dependent on climate, 7.
- Kern County Land Co., 129.
 Kern River Canal Co., 129.
 Kutter's formula, 66.
- Lift-pump, 105, 106.
- Limit of irrigation in Arid America, 147.
- Linings, Reservoir, 78.
- Loss of head in entrance and discharge pipes, 107, 112.
- Masonry dams**, 71.
- Meadow irrigation, 7.
- Measurements of water, 67, 68, 69, 70.
- Miners inch, 11, 70.
- Minimum volumes of embankment, 161.

- Moist soils, evaporation from, 29.**
Moisture, contents of saturated air, 23.
 Excessive, 6.
 Free, 3.
 Hygroscopic, 3.
 To moisten soil, 5.
 Plant requirements, 3, 4.
 Sensitiveness of crop to, 7.
 Soil disposition, 4.
Motors, poly-phase, cost of, 119.
Mulches, effect on, evaporation, 26, 31.
Onions, irrigated and unirrigated, 8.
Open bottom wells, 79.
Operation, pump plants at Bakersfield, 137.
 Steam Pump Plants, cost of, 122.
Pipe for float cut outs, 135.
 Friction in, tables, 108 to 112.
 Redwood, cost of, 59.
 Reinforced concrete, 60.
 Wooden, cost, 60.
 Depreciation, 60.
 Capacity, 60.
Pit-pump at Bakersfield, 132, 133.
Plants, growth of, 4.
Plant growth, moisture for, 3, 4.
Porous media, Flow of water in, 52, 53.
Power, choice of for pumping, 113, 114.
 Plunger pumps, 115.
 for pumping, 103, 104, 105.
Pulsometers, 115, 116.
Pump efficiency, 103.
 Frames, vertical, 130.
 Installation at Bakersfield, 130, 131.
 Lift, 105, 106.
 Plant calculation, 125, 126, 127.
 Plant operation, cost of, 122.
Pump plants, cost of in Texas, 121.
 Fuel consumption, 122.
 Operation of, at Bakersfield, 137.
 Reservoirs for, 199, 202.
 Test of, at New Orleans, 124, 125.
Pump stations, cost of, 118.
 Design of, 113.
 Performance at Bakersfield, 138, 139, 140.
Pump tests, 106, 107.
Pump Water, cost of, 38.
Pumping Water, cost analysis, 119, 120, 121.
 Method of charging for, 142, 143, 145.
Pumping, cost of at Bakersfield, 138, 139, 140.
 Engines, 115.
 for irrigation, increase of, 113.
 Power for, 113, 114.
Pumps, air lift, 115, 116.
 Boiler, cost of, 118.
 Centrifugal, 115, 116, 119.
Pumps — Continued
 Deep well, 115.
 Direct acting steam, 115.
 Hydraulic ram, 115, 117.
 Power for, 103, 104, 105.
 Power plunger, 115.
 Pulsometer, 115, 116.
 Pumping engines, 115.
Puddle, 75.
 Lining, cost of, 78.
Ram Hydraulic, 115, 117.
Rate of flow, 11.
Rating flume, 69.
Reclamation service, 43.
Redwood pipe, cost of, 59.
Reservoir, clearance, 154.
 Efficiency, 184, 185.
Reservoir embankments, construction, 77, 180.
 Cost of, 76, 77, 78.
 Section, 179, 180.
 Composition of, 78.
Reservoir location, value of, 45, 46.
 for pump plant, 199, 202.
 Water, cost of, 45.
Reservoirs, advantages of, 150, 152.
 American, 181, 182.
 Artificial, 74.
Reservoirs, artificial, advantages of, 47, 48.
 Artesian well, 187 to 198.
 Artesian well, assumed cases, 191, 192.
 Artesian well, design, 191 to 198.
 Capacity of, 205 to 208, 219.
 Capacity and volumes of Embankment, 209 to 215.
 Cases assumed, 155, 168, 169, 172, 173, 174, 203, 204.
 Correction factor for, 226.
 Design of, 169 to 171; 174 to 179; 220 to 228.
 Embankment construction, 185.
 Embankment volumes, 216, 219.
 Field for, 166.
 Function of, 46, 47, 48.
 Economic use of, 199 to 202.
 Large; capacity of, 162.
 Lined, 173, 174.
 Minimum embankment, 217, 218.
 Notation, 155, 167, 203, 204.
 Sloping ground, 172.
Reservoirs, contrasted, artificial and natural, 183, 184.
 Natural and artificial, 43.
 Natural, construction of, 70.
 Natural, considerations for, 44.
 Risk of damage to, 185.
 Small, advantages of, 40, 41.
Rock fill dams, 73.

- Salts, rise of in soil, 5, 6.
 Sand trap, 64.
 Saturation, moisture of air, 23.
 Soil, 3.
 Semi-arid Zone of the U. S., 1, 2.
 Sluice gate, 64.
 Soils, deep, storage of water in, 5.
 Moisture disposition, 4.
 Saturation, 3.
 Void space, 3.
 Specific capacity of wells, 97.
 Spillway, 70, 71.
 Sprinkler irrigation, 20, 21.
 Steam engines, cost, 117.
 Efficiency, 117.
 Steam plants, 118.
 Fuel consumption, 122.
 Steam pumps, direct acting, 115.
 Steam pump plants, cost of, 121.
 Cost of operation, 122.
 Stevensons formula, 155.
 Storage in soils, Heavy irrigations, 13.
 Storage of water, cost of, 45.
 Stored water, method of charging for,
 144, 145.
 Strainers for wells, 79, 80, 81.
 Streams, flow of as supply, 42, 43.
 Subirrigation, effect on evaporation,
 27, 32.
 Surface irrigation evaporation, 32.
 Suppressed weirs, 67, 68, 69.

 Tablet irrigation, 20, 22.
 Tanks, earth, 74, 75, 199 to 202.
 Temperature air, 28.
 Evaporation, 24, 29.
 Soil, 28.
 Water, 28.
 Tests, pump, 106, 107.
 Timber crib dams, 73.
 Time element automatic cut out, 135.
 Transformer house, 134.
 Transpiration loss, light—effect on, 4, 5.
 of crops, 35.
 Truck irrigation, value of, 41.

 Underground supply, 49, 50, 51, 129.
 Water flow, 51.
 Unsuppressed weir, 67, 68, 69.

 Value of crops, 37.
 Irrigation, 6, 7.
 Velocity canal, 56.
 Flume, 58.
 Head, 107.
 Inverted siphon, 59.
 Void space, soil, 3.

 Waste gate, 64.
 Wave height, 155.
 Water, application, cost of, 20, 37, 39.
 Artesian, cost of, 189, 190.

Water — Continued
 Conduction and distribution, 55.
 Duty of, 11, 15, 16, 17, 34, 35, 36, 37,
 39, 138, 172.
 Economy, 6.
 Measurement, 67, 68, 69.
 Procedure before diverting, 42.
 Pumping cost, 38, 119, 120, 121.
 Rights, 3, 42.
 Storage in deep soils, 5.
 Supply, flow of streams, 42, 43.
 Surfaces, evaporation from, 29.
 Well, cost of, 100, 101,
 Weirs at Bakersfield, 133.
 Cippoletti, 67, 68, 69.
 Suppressed, 67, 68, 69.
 Unsuppressed, 67, 68, 69.
 Well water, air entrained, 137.
 Cost of, 100, 101.
 Cost of Artesian, 189, 190.
 Wells, artesian, 86.
 Cost of in Texas, 190.
 Flow increase by pumping, 92.
 Reservoirs for, 187 to 198, 227, 228.
 Reservoirs with assumed cases, 191,
 192.
 Wells at Bakersfield, 132.
 Boring, cost of, 99, 100, 101.
 Casing for, 100.
 Change of flow, 86, 87.
 Cleaning, 82.
 Calculation of flow, 91 to 96.
 Depression of water in, 85.
 Draft of water, 82.
 Elevation of water from, 82.
 Friction in entrance to, 80.
 Hydrostatic level, 85, 87, 93.
 Interference, mutual, 85.
 Kinds of, 98.
 Law of flow, 86, 88, 89, 90.
 Leakage of water in, 87.
 Legislation advisable, 100.
 Open bottom, 79.
 Output of, at Bakersfield, 140.
 Pumping from, 83.
 Sinking, 79, 98, 99.
 Specific capacity of, 97.
 Strainers, description, 81.
 Supply, storage of ground, 97.
 Test of flow, 88, 89, 90.
 Testing, 100.
 Water level fluctuation, 93, 94, 130.
 Water strata, 82.
 Wild flooding, 20.
 Wind, effect on evaporation, 24, 29.
 Wooden dams, 73.

 Zanjero, 142.
 Zones of the U. S. Arid, 1.
 Humid, 1.
 Semi Arid, 1.

