



FOOT-POWER LOOM WEAVING

BY

EDWARD F. WORST

*Supervisor of Elementary Manual Training and
Construction Work, Chicago, Ill.*



THE BRUCE PUBLISHING COMPANY
MILWAUKEE, WIS.

Copyright, 1918
by
Edward F. Worst

OCT 26 1918

©CL.A503972

no 1

INTRODUCTION



THE suggestions offered in this manual are for those who believe that the more advanced weaving should be pursued as a most wholesome occupation and that it should again, in the near future, find a place not only in the school but also in the home. Few lines of occupation furnish more excellent opportunity for color combination and design than does the craft of weaving.

Girls taking the various household-arts courses will find weaving a great aid in understanding the structure of a piece of cloth.

The work is so full of possibilities and the results obtained have such a wonderful effect on the character of the worker that these alone afford ample reasons why weaving should be carried on in both school and community.

The descriptions given are for the amateur weaver who will find them more easily understood than those given in the more technical books on the subject.

It is hoped that those interested will find help through the suggestions offered in this manual.

EDWARD F. WORST.



Table of Contents

CHAPTER I

THE LOOM, WARPING AND THREADING — Loom Weaving — The Construction of Plain Cloth — The Essential Parts of a Loom — Preparing a Long Warp — Construction of Warp Board — The Warp Board in Use — Taking Off the Warp — The Warping Reel — Alternate Method of Warping Four Threads — Keeping Account of Threads Warped — Warping a Number of Threads at Once — Turning On, or Beaming — The Warp Spreader or Raddle — Laying in Sticks — Knotting the Heddles — Heddle Sticks — Threading the Loom — The Reed — Threading the Reed — Placing the Reed — Tying the Loom — The Cloth Beam — The Shed — The Small Shuttle — The Bobbin Winder — The Temple — The Reel..... 7-42

CHAPTER II

PATTERN WEAVING — Rag Rugs — Introducing Color — Plaids — Pattern Weaving — Beginning the Threading — Threading the Reed — Tying the Heddle Sticks — Tying Heddle Sticks to Treadles — Weaving the Pattern — Weaving a Border — Second Change in Pattern — Checked Paper — Adaptations of Patterns — Rose Path Pattern — Threading for the Rose Path Pattern — Weaving the Pattern — Fine Threads Used for Warp — The Lambs..... 43-58

CHAPTER III

COLONIAL PATTERNS — Reading a Pattern Draft — The Big Diamond Pattern — The Tie-Up — Weaving the Pattern — Double Snowball Pattern — Where to Begin the Threading for Large Patterns — Block Work Pattern — Chariot Wheel Pattern — The Orange Peel Pattern — Governor's Garden—Bonaparte's March Pattern—Weaving Borders — Snail's Trail Pattern — The Blooming Flower Pattern — Pine Knot Pattern — Federal Knot Pattern — Wheel of Fortune Pattern — Irish Chain Pattern — The Tie-Up of Irish Chain — Rings and Chains — Old Quilt Pattern — Miscellaneous Patterns — Wind Flower Pattern —Whig Rose Pattern..... 59-100

CHAPTER IV

DANISH AND NORWEGIAN WEAVING — Expressing Danish Patterns — Reading a Danish Draft — Tying the Treadle — Danish Patterns..... 101-105

CHAPTER V

SWEDISH WEAVING — Swedish Way of Writing a Draft — Irregular Threading — Three-Harness Draft — Eight-Harness Pattern — Heddle Frames — Tie-Up for Two Sets of Lambs — Six-Harness Pattern — Six-Harness Loom — Eight-Harness Loom — Miscellaneous Swedish Patterns.. 106-150

CHAPTER VI

DAMASK WEAVE — Double Weave — Damask Weave — Threading the Reed — Tie-Up — Ten-Harness Tie-Up — Table Mat — Rug Weaving in Wool — Operation of Treadles — Double Weaving — Threading Double Weave Pattern..... 107-165

CHAPTER VII

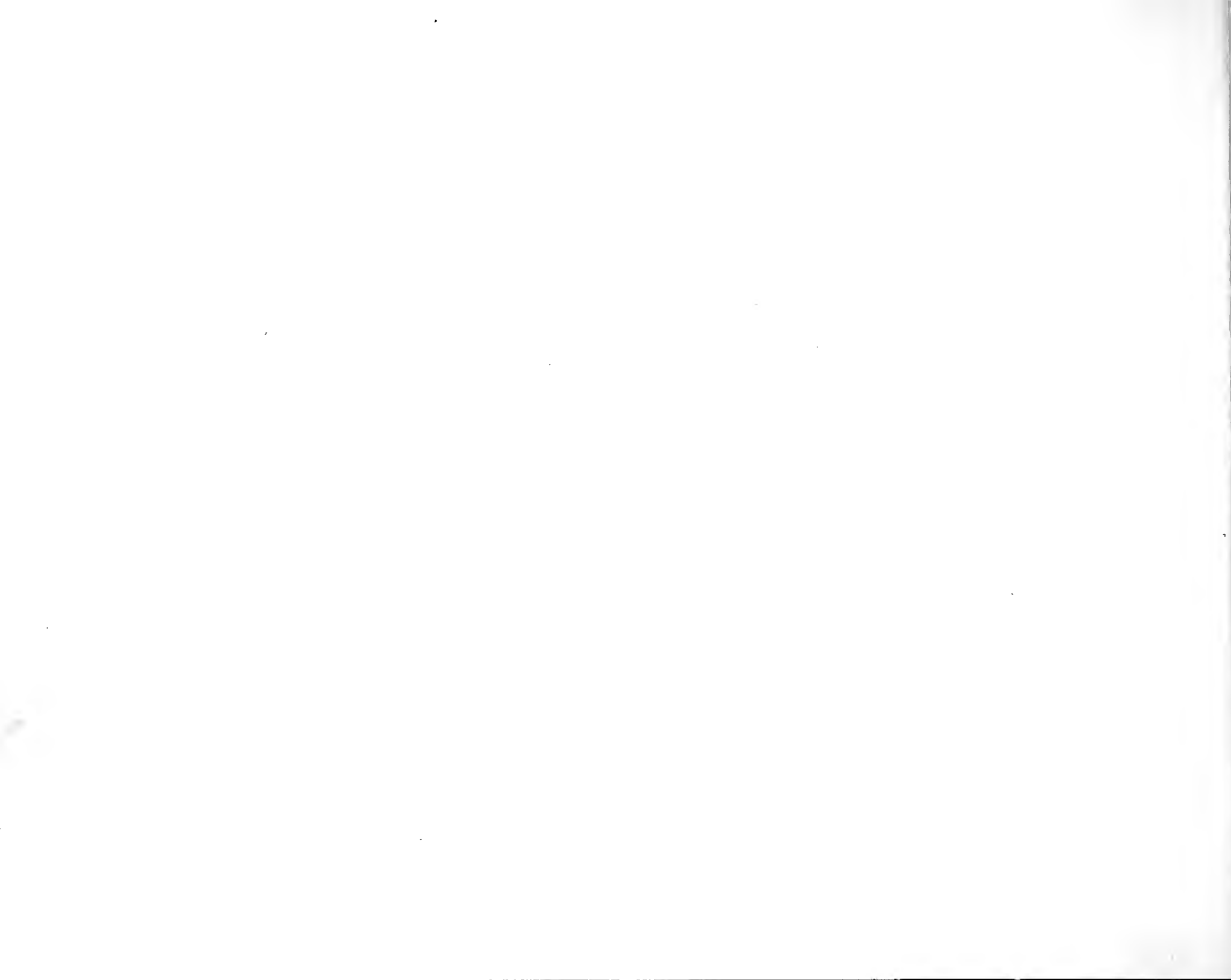
TEXTILES AND WOOD — Combinations of Textiles and Wood —Foot Stool—Waste Basket—Screens..... 166-174

CHAPTER VIII

DESIGN AND CONSTRUCTION OF LOOMS — Danish Looms—Swedish Looms..... 175-182

CHAPTER IX

DYES AND DYEING — Utensils Used — Washing of Wool — Water Used in Washing — Mordant — Formulae for Dyeing — Yellows — Reds — Preparation of Olium — Blue Dyes — Green Dyes — Violet Dyes — Violet With Cochineal — Violet With Cochineal, or Madder — Brown Dyes — Gray Dyes — Black Dyes — Further Use of Used Dye Liquids — Yellow After Dyes — Red After Dyes — Blue After Dyes — Violet After Dyes — Green After Dyes — Dyeing of Old Goods — Bleaching Woolen Goods — Hand Measures..... 183-208



Foot-Power Loom Weaving

CHAPTER I

The Loom, Warping and Threading

Loom Weaving

Notwithstanding the introduction of the power loom and all its wonderful possibilities, the hand loom still survives and seems likely to continue in use since numerous schools and handicraft societies as well as many independent art workers are becoming interested. This gives hope that at some time in the near future the domestic occupations of weaving and spinning in both flax and wool will again find a place, not only in the home but also in the studio and in the industrial school. The appreciation of handwork has, during the past decade, increased in the estimation of the public.

In various European countries, as well as in India, China and Japan, hand loom weaving still continues. In Norway and Sweden a very successful line of home industry is carried on to great advantage to many women who find it necessary to aid in the family support. This may also be said of the women in the Orkney and Shetland Islands.

Of late much has been written of the beautiful hand-weaving done by the women in the mountains of Kentucky and Tennessee. So attractive is this work that little difficulty is experienced in disposing of the articles woven.

Since the introduction of machine spinning and weaving, no home industry which approaches them in usefulness or interest has taken their place. It is true that there are many lines of weaving now produced by the machine, too intricate to be attempted on the hand loom, but the weaving of linen, cotton, woolen and the coarser silk threads into materials of strength and beauty for home use, can quite well be carried on in the studio and even by the homemaker who has other household occupations.

There is no doubt as to the superiority of a well made, hand-woven article. This is plainly shown if the hand-made and the machine-made articles are compared. Hand loom weaving, too, is superior to machine weaving if judged by the effect it is

likely to have on the worker. The hand weaver is employed in a pleasant, ingenious occupation which exercises all his faculties, while the attendant on a power loom is engaged in a monotonous toil in which no quality but intense watchfulness is required.

The object of this manual on weaving is to give to the amateur weaver the benefit of the author's experience in preparing the fibers, the warping and the threading of the loom for plain weaving, as well as learning to interpret and to execute various pattern drafts used in our own country and in other countries.

Through the exercises given it is hoped the weaver may be led to invent and to work out many interesting and original designs.

The Construction of Plain Cloth

If a piece of plain cloth is examined it will be found to consist of a number of longitudinal threads placed side by side and interlaced by a continuous single thread. The latter thread passes alternately above and below or before and behind the longitudinal threads. Fig. 1 shows the arrangement of the longitudinal threads and the continuous thread crossing and intersecting them.

The longitudinal threads of a piece of woven material are always called the warp. They are so named, because, in order to allow their being inter-

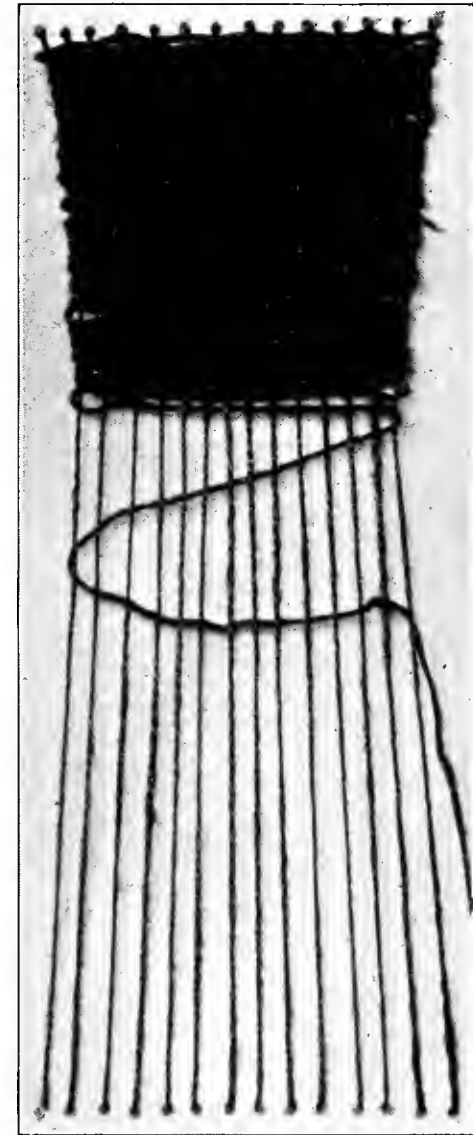


Fig. 1—A Piece of Plain Cloth

sected conveniently by the continuous crossing thread they have to be warped, that is, tightly strained in position on some kind of frame prepared for the purpose. The continuous crossing thread has several names, such as weft, woof, or shoot (shute).

If the warp threads are carefully examined they will be found to consist of several fine threads twisted together. This is done to give added strength. The weft may be single and the thread only slightly twisted, as this makes it soft so the warp and weft are easily pressed together into a firm material.

The weaving of mats and baskets from local materials and from raffia, reed and willow may be done without any special appliance for holding or stretching the material while it is being woven.

When fine thread is to be woven the problem is very different, and it becomes absolutely necessary to devise some kind of frame to hold and stretch the warp upon, so that the weft may be readily interlaced with it. The more elaborate frame constructed for this purpose has by universal consent been called a loom.

The Essential Part of a Loom

In all the ancient pictures of looms the stretched warp threads are shown and the insertion of the

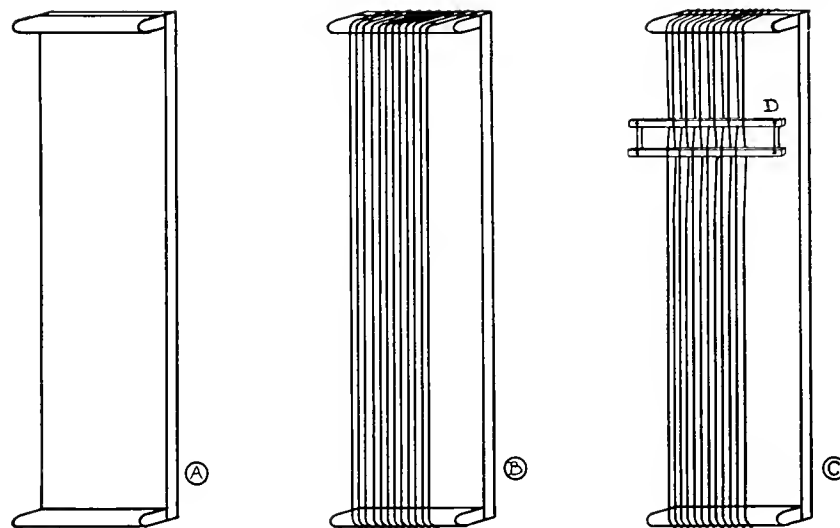


Fig 2—Simple Loom

weft threads is suggested; but the lease, the one universal and indispensable contrivance used in weaving, has been omitted. While not shown, it must have been there, for no loom could be operated without it.

Fig. 2 illustrates the three steps in the construction of a simple loom. The construction is similar to the looms made by the pupils of the lower grades.

Fig. 2, "A" shows the loom without the thread.

"B" shows the warp threads wound upon it lengthwise.

“C” shows the strings on the board intersected by two rods, “D,” in such a way that alternate strings go over and under each rod. In the space between the rods the alternate strings cross each other in regular succession. While the rods “D” are kept in their position in the warp it is impossible for the threads to get out of place or to get hopelessly entangled, as they certainly would if any great number of threads were used.

This cross is called the *lease* and is really the one indispensable part of the loom. No two looms may be alike in any other respect but in the case of the lease. One cannot dispense with this simple yet perfect contrivance for keeping the warped threads in order when a long warp made up of hundreds of threads is required.

Preparing a Long Warp

A warp longer than the loom cannot be made upon the loom as was shown in A, B, C, Fig. 2.

This being true, some sort of apparatus must be constructed on which to build up a series of threads of exactly the required length and number of threads. These threads must be held in exactly the same tension so that when transferred to the loom and stretched between its front and back beams they shall give the weaver as little trouble as possible with loose threads.

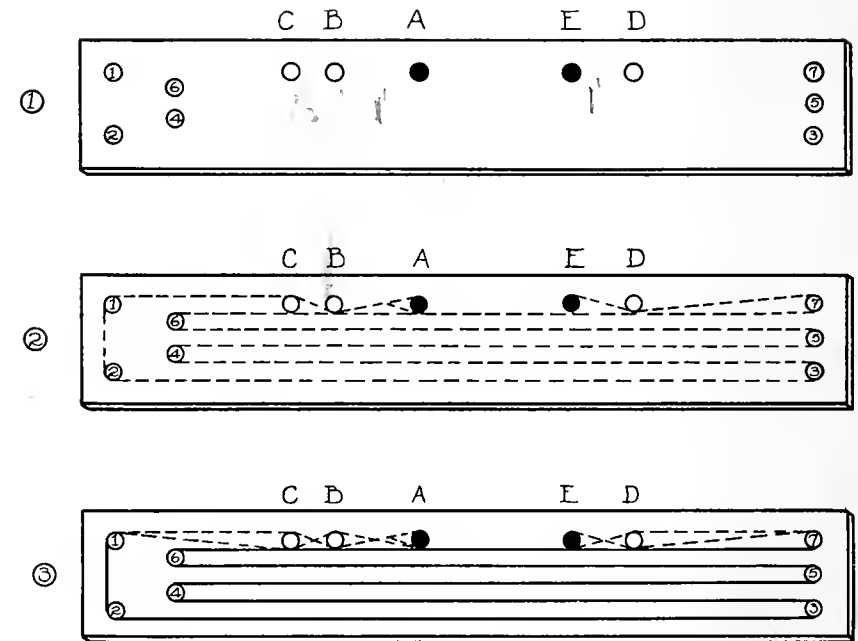


Fig. 3—Use of Warping Board

This process of preparing the threads is called *warping*. There are several ways of doing the warping.

Construction of Warping Board

Fig. 3 shows the construction of a warping board. On this board may be warped a moderate number of threads, such as would be required for a foot-power loom. The warping board makes it possible to illustrate perfectly the principles of warping.

The board shown in Fig. 3 (1, 2 and 3) is six feet long by one foot wide. It is made to hang firmly on a wall at such a height from the ground that the operator can reach to any part of it without difficulty.

On a board, the size indicated in Fig. 3, a warp ten yards in length may be warped. A longer length may be warped either by increasing the length of the board or by increasing its width and adding to the number of pegs. The pegs should be made of hard wood not less than six inches long and one inch in diameter.

The pegs marked A and E must be movable, perfectly smooth and have nicely rounded ends. The space between A and B should not be less than one foot, and the space between B and C, six inches. The space between D and E should also be one foot. (No. 1, Fig. 3).

The Board in Use

Let the problem at hand be to make a warp of thirty threads ten yards long.

Place a spool of ordinary four-ply carpet warp on end in a receptacle of some kind in order that the thread may freely unwind. If a spool rack may be conveniently had the spool may be slipped on to one of the rounds of the rack. Tie the free end of the spool of warp to the movable peg A, No. 2,

Fig. 3. Guide the thread *under* peg B and *over* peg C. Then follow the dotted line, as shown in No. 2, Fig. 3, by allowing the thread to pass outside the pegs 1, 2, 3, back to 4, then to pegs 5, 6 and 7, until it reaches peg D, which it goes under. Carry the thread now over and under peg E, and then begin its return by carrying the thread over D, No. 3, Fig. 3, on to peg 7 (see dotted lines) and so back in the same course, until we again reach peg 1. It must now be taken below C, over B, and below A (see dotted lines). This completes one course. The warping board should now look like No. 3, Fig. 3, with the threads crossed between pegs B and C, and D and E. Two threads have now been warped, having a length of ten yards between the crosses.

The second thread having been carried around and over peg A, went under B and then followed exactly the course of the first thread until it reached E. Then, following the second thread back it reaches A, goes under and over the peg, and four threads out of the thirty are warped. By the time fifteen forward and fifteen backward journeys are made the sample warp of thirty threads is finished and may be taken from the board as soon as the crosses have been made secure.

One can readily understand by the above explanation that a great amount of time would be consumed in making a warp by handling one thread

at a time. Since four-ply carpet warp is to be used for the first warping, four spools may be placed on the spool rack, the four ends tied to the proper peg at one time and then the course pursued with the four threads, as was described for only one thread. This causes four threads to pass under and over the pegs instead of one. On account of the coarseness of the warp there is little or no danger of the threads becoming tangled. A more detailed explanation of running more than four threads will be given later. The above, however, works very successfully.

Securing the Crosses

The important matter of securing the crosses is easily done, but if forgotten the warp will be spoiled when it is removed from the board.

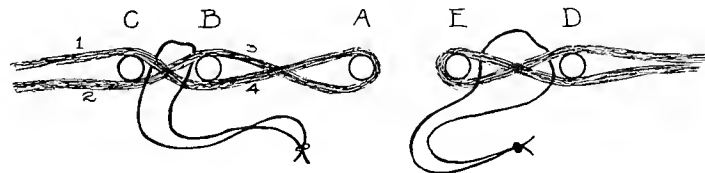


Fig. 4—Securing the Crosses

Fig. 4 shows clearly the way it is done. The letters indicate the pegs of the warping board, the heavy lines are the threads of a warp, which may be of any number of threads.

The important crosses are shown between C and B and between D and E. A thin, pliable cord

about two yards long is now drawn in at each cross from the back to the front, through the openings in front of the pegs. Tie the ends of the cord as shown in Fig. 4. By this means the crosses are perfectly secured.

It will be observed that there is another cross in the warp between B and A. This is not so important. A short cord may be drawn through the loop at peg A, and the threads may be tied all together.

The warp may now be removed from the board and made into what is called a chain.

Taking Off the Warp

The warp is taken off the warping board for convenience in transferring it from the board to the warp beam of the loom.

The crosses having been made secure, the warp is ready to be removed from the board. The long strings between the crosses may be wrapped around the warp to prevent them from hanging in the way.

First remove the peg A, Fig. 5. Allow the warp to slip from the other pegs, B and C, and also No. 1, Fig. 5. Hold the warp with the left hand about two feet from the end. While the warp is being held with the left hand, throw the end over the warp with the right hand, as shown at F, Fig. 5.

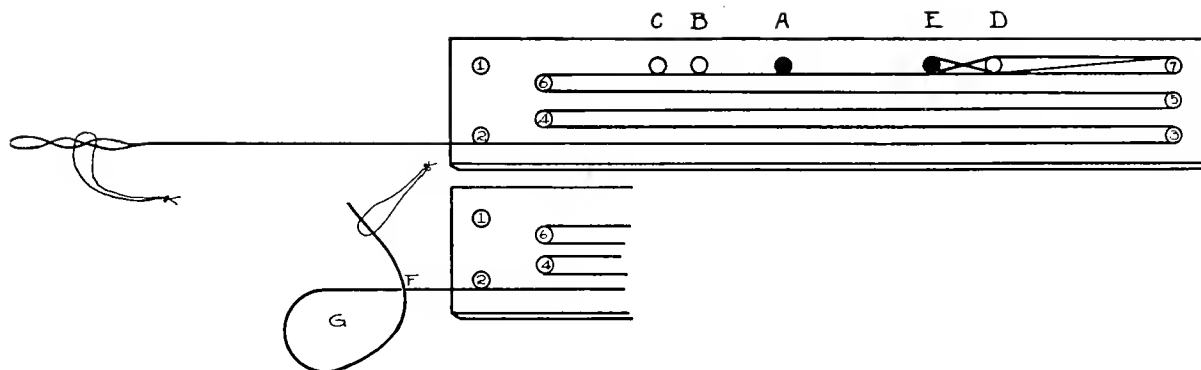


Fig. 5—Taking Off the Warp

This makes a kind of loop. With the left hand still holding the warp, the right hand is put through the loop at G, Fig. 5. The warp is grasped and drawn through the loop far enough to make a second loop, held by the right hand. The left hand is now free and is put through the new loop held by the right hand. The warp is grasped and drawn through the new loop thus making a third loop held this time by the left hand. The right hand being free is put up through the third loop, the warp is grasped and drawn through the loop. This is continued until the entire warp has been removed from the board.

The process of taking off the warp will be recognized as the same as making a chain stitch in crocheting, the hands doing the work instead of a hook. See Fig. 6.

Before placing the warp, which may now be called a chain, on the warp beam of the loom, another method of warping will be considered.

The Warping Reel

The use of the warping reel, sometimes called the warping mill, somewhat simplifies the process of warping. Fig. 7 shows a working drawing of a warping reel, and Fig. 8 shows the finished reel.

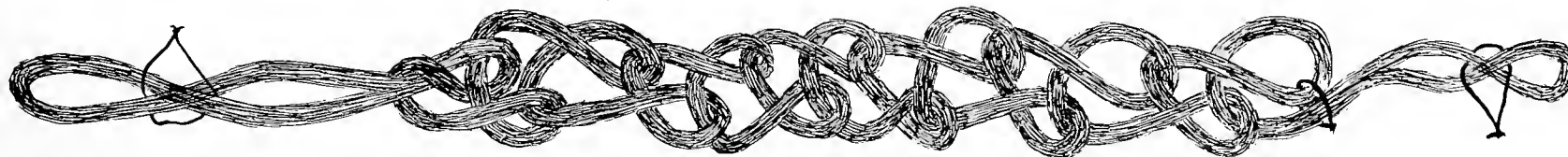


Fig. 6—Chain made with warp from warping board

Bill of Material			
No	Name	Length	Width Thickness Diam
1	Rod	60	1 1/2 Diam
2	Base	24	2 1/2 1 1/2
1	Bottom	6 1/2	6 1/2 1
1	Plate	5	Diam 1
1	"	3	" 1/2
4	Braces	13	1 1/2 1
4	Pieces	40	3 1
4	Sides	48	2 1
2	Rails	26	2 1 1/4
5	Dowels	5	1/2 Diam

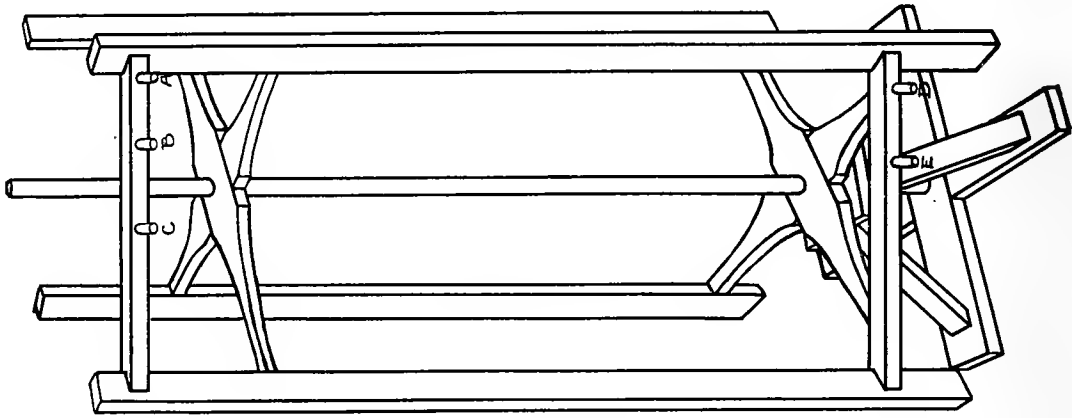
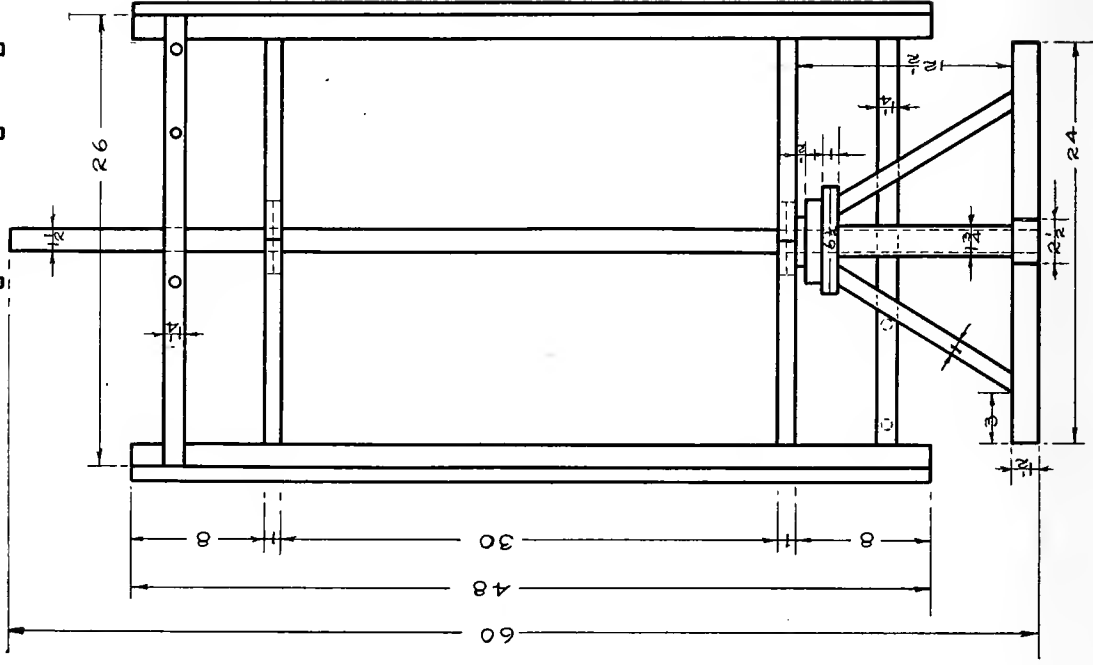
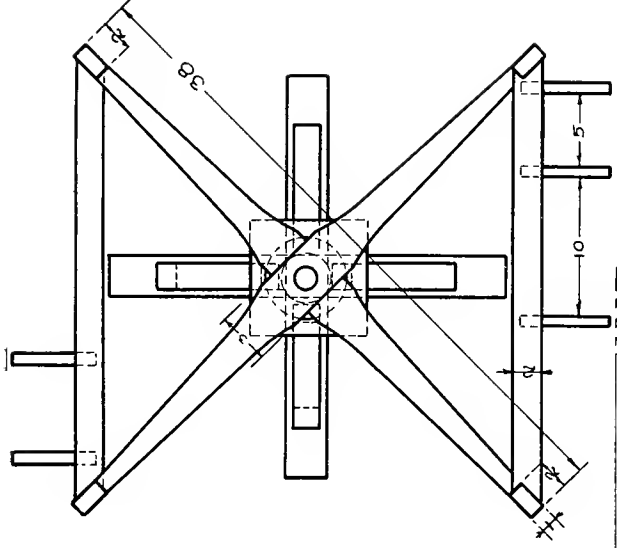


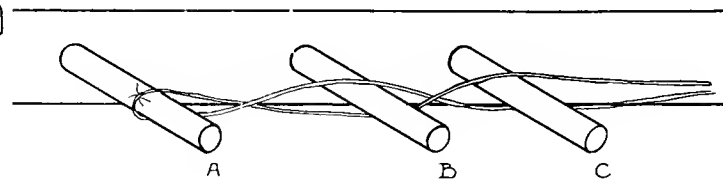
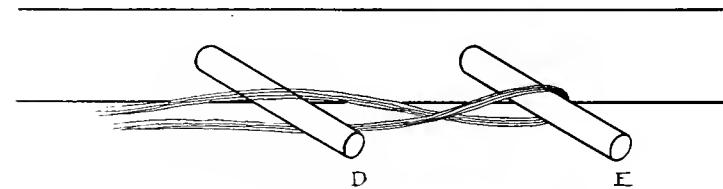
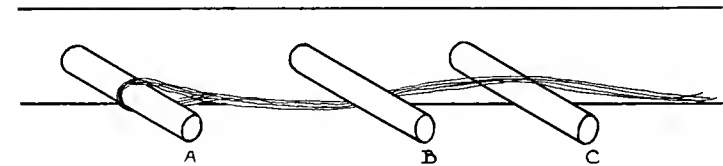
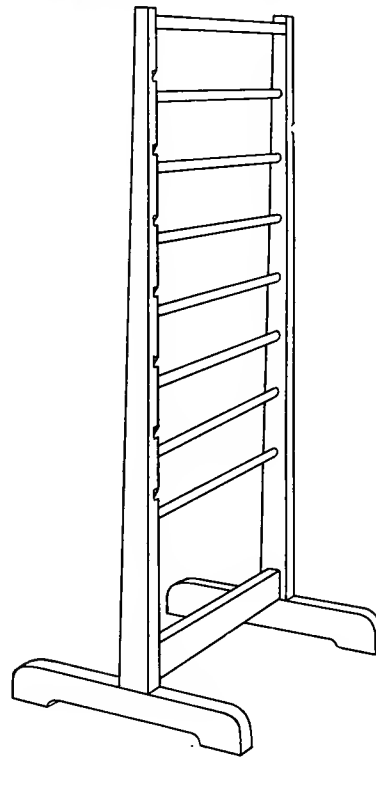
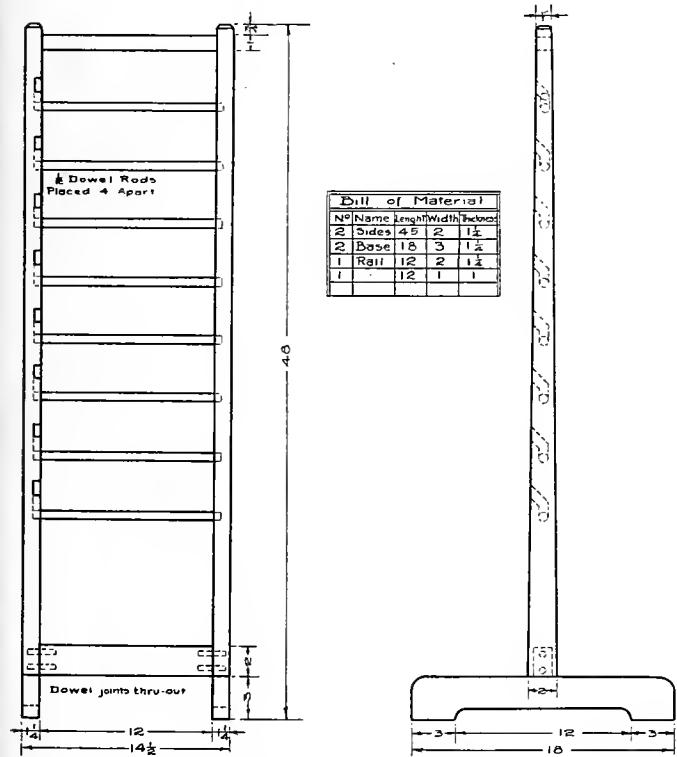
Fig. 8—Warping Reel

Fig. 7—Working Drawing of Warping Reel

It will be observed that the pegs appear on the cross bars of the finished reel marked A, B, C, and D, E, the same as on the warping board. The distance between the upright posts of the reel is 27 inches. The spools of warp are placed as when the warping board was used. Some sort of a spool rack is almost indispensable. Yet any convenient way of arranging the spools so the thread will freely unwind, will answer the purpose. Fig. 9 shows the

working drawing of the spool rack and Fig. 10 shows the finished rack.

Supposing that four threads are to be warped at one time. The four ends are all tied at one time to peg A, Fig. 11. They are carried under B and over C and then start on their way around the reel, the threads being guided on their way to pegs D and E by the left hand while the reel is turned by the right hand. The person performing the work remains



2 Fig. 9—Working Drawing of Spool Rack

Fig. 10—Spool Rack

Fig. 13—Another Method of Starting Threads

stationary. On reaching peg D the group of four threads is carried over it, under and around E and back under D, as shown in Fig. 12. From here the threads start back toward pegs A, B and C, passing under C, over and under and around A, under B and over C, as in the beginning.

The reel measures 27 inches between posts. Passing around the reel once is equal to three yards of warp. Knowing this, makes it an easy matter to measure off any number of yards.

Another Way to Begin With Four Threads

The four threads may be tied together and slipped on to peg A, two threads being on top of the peg and the other two below. Bring the two threads which are below A, over B, and the two above A, below B. Allow the two below B to pass over C and bring the two above B so that they pass below C, Fig. 13. From this point the four threads are guided around the reel just as above described. The four threads pass over and under D and E, as shown in Fig. 12. On their return to peg A the four threads pass under the pegs the two went over, and over the pegs the two went under, and the warping proceeds in the same manner as when using the warping board.

Keeping Account of the Number of Threads Warped

As soon as the threads have crossed a few times between pegs D and E, it will be found difficult to

remember how many threads are gathered together on the pegs. It becomes necessary to use some device for keeping count in order to know when the warp is completed.

This account can be easily kept if a piece of cord or tape is used.

After the group of four threads passes between pegs D and E five times, draw one end of the cord or tape through the opening next to peg D and the other end through the opening next to E, as shown in Fig. 14.

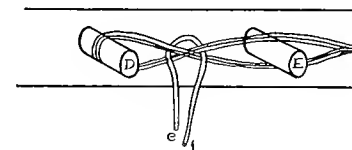


Fig. 14—Keeping Account of Threads Warped.

The warping continues until five more groups have been warped or reeled, as the process is sometimes called. The end of the colored cord or tape marked "f," Fig. 14, is now passed through the opening next to peg D, and the end of the cord or tape marked "e" passes through the opening next to peg E, thus making a cross in the cord or tape between the first group of five and the second group of five. As there are twenty threads in each group the worker knows that the warp contains forty threads. This is continued until the required number of threads has been reeled.

The cross at the beginning and the one at the end of the warp are now secured in the same way as when the warp is made on the warping board.

Removing the Warp from the Reel

Peg A is removed and the warp is slipped from pegs B and C. A chain is made the same as when removing a warp from the warping board. See Fig. 15.

To Warp a Number of Threads at Once

If only four or six threads are warped at a time these may easily be carried and placed over and under the pegs in a group. It will be learned a little later that, when the lease rods are placed, either four or six threads, according to the number warped at a time, will pass over and under the rods at one time.

When eight, ten, twelve, or sixteen threads are warped at a time the problem is somewhat more complicated and should be done in such a way as to bring alternate threads over and under the lease rods. This arrangement of the threads makes the threading of the loom easy and keeps the threads from becoming snarled or twisted one with another. Arrange the spools on the spool rack, as shown in Fig. 16.

A paddle-shaped piece of $\frac{1}{4}$ " or 3-16" basswood is cut as shown in Fig. 17, to serve as a guide. Any number of holes may be bored. Sixteen is usually



Fig. 15—Removing the Warp from the Reel

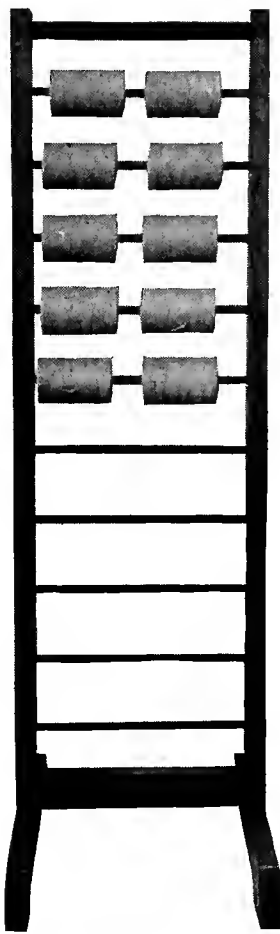


Fig. 16—Spools on Rack

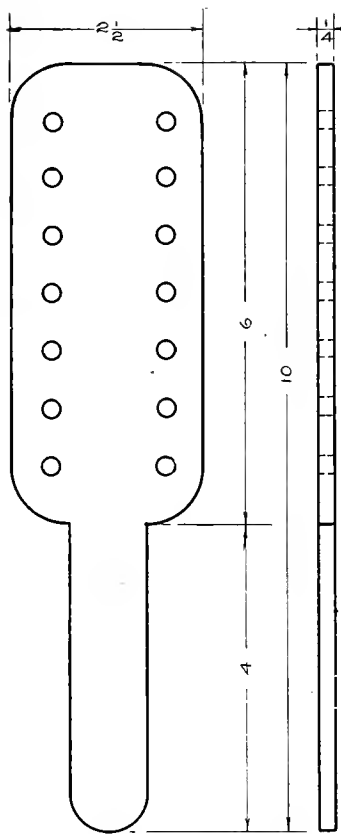


Fig. 17—A Paddle

the greatest number for the amateur. The ends of the threads coming from the spools on the left side of the rack and all unwinding in the same direction are threaded through the holes in the left side of the guide, Fig. 17A, and the ends coming from the spools on the right side of the rack are threaded

through the holes in the right side of the guide, 17A. The ends are now all gathered together and tied in one knot and slipped over peg A of the warping reel, four threads being on top and four below the peg, the threads fixed to peg A, Fig. 17A. The guide is held in the left hand in an upright position so the threads are well separated. With the first finger and thumb of the right hand the threads (warp) must be crossed. This is done by placing the first finger of the right hand on the lowest thread on the right side of the guide and pressing it downward, Fig. 18. The thread just pressed down passes under the finger and over the thumb. With the thumb press down the lowest thread on the left side of

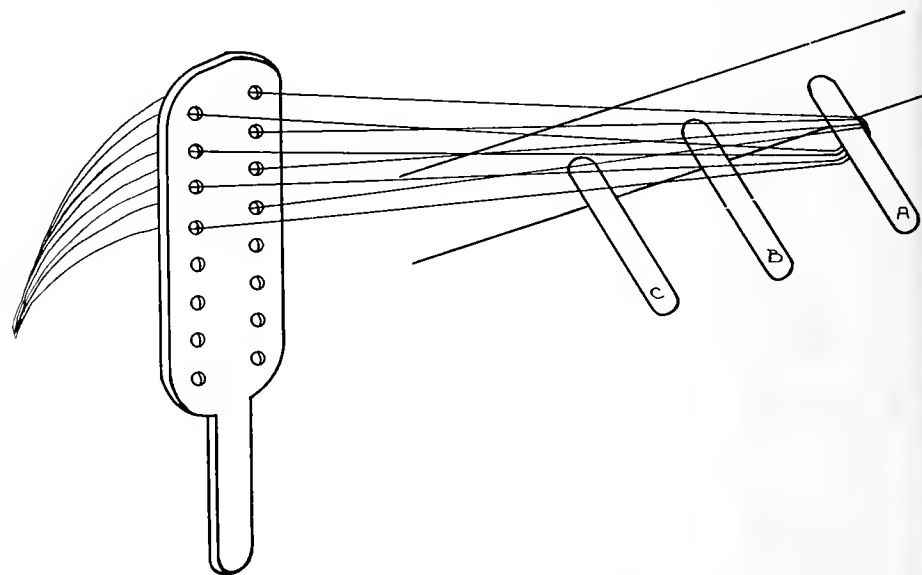
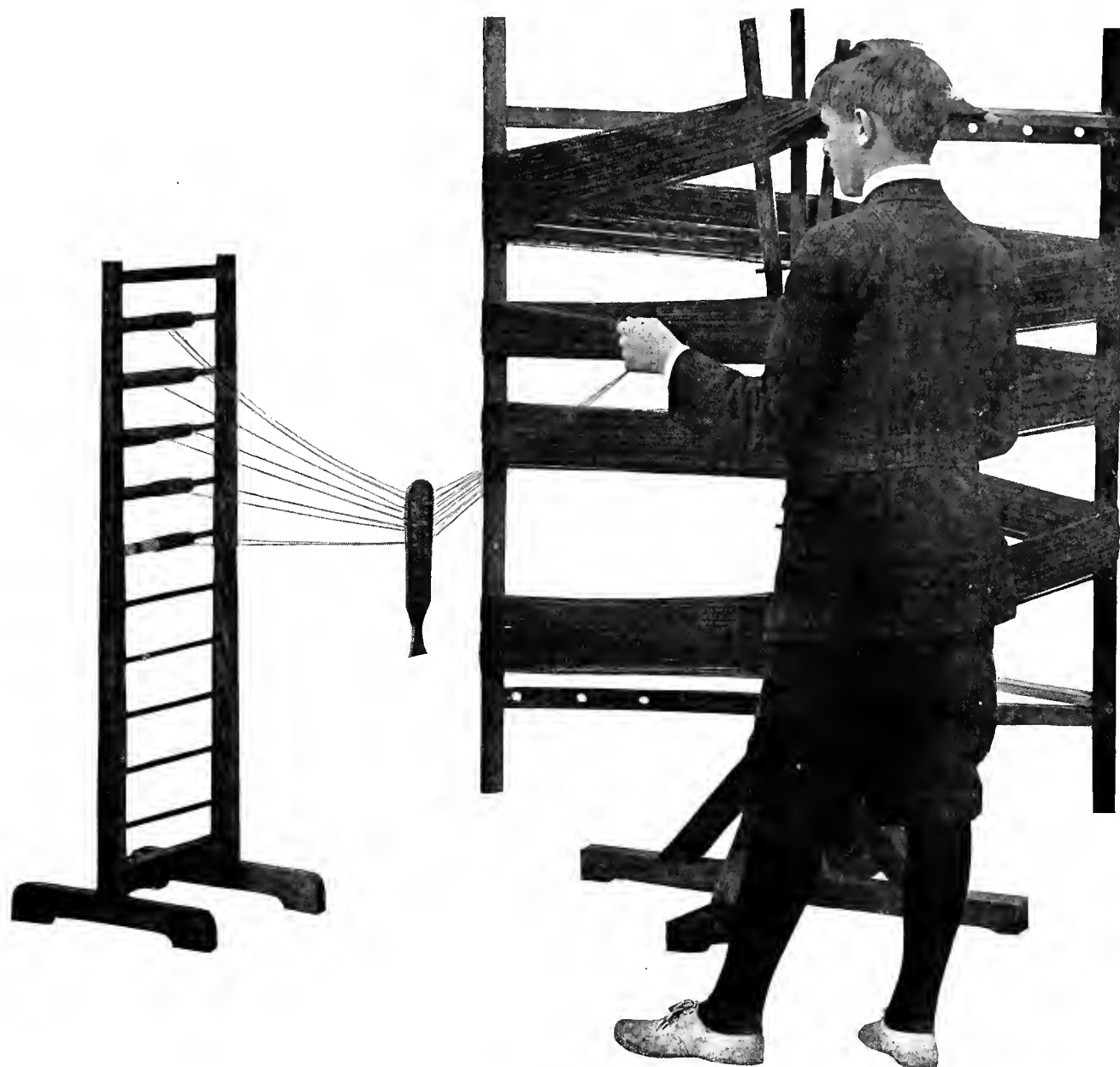


Fig. 17A—Method of Using Paddle



Reeling Eight Threads with Paddle

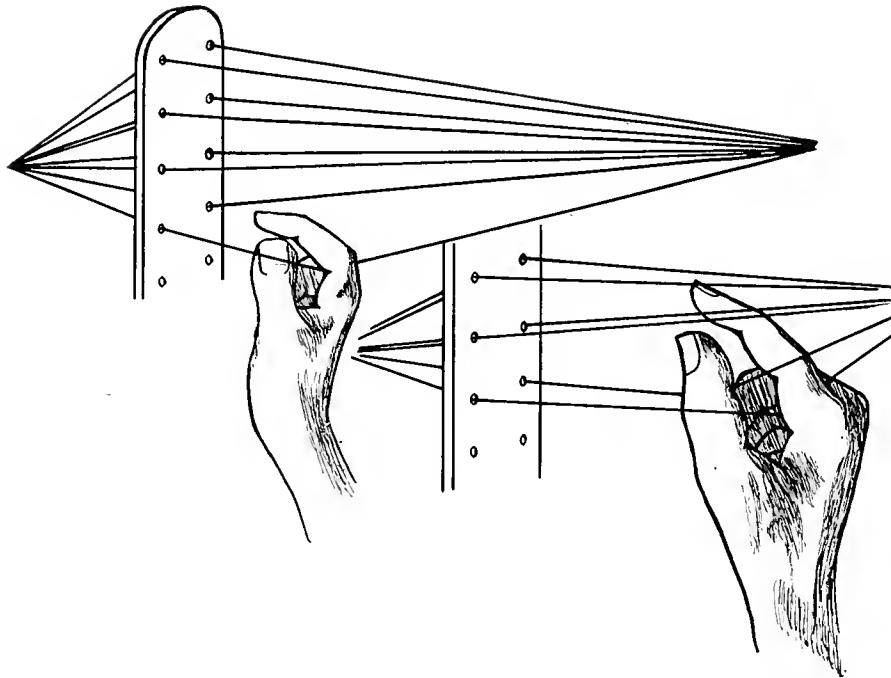


Fig. 18—First Thread Pulled Down Fig. 19—Second Thread Pulled Down

the guide, Fig. 19. This thread passes under the thumb and over the finger. Allow the finger to press down the second thread on the right side of the guide. This thread now passes under the finger and over the thumb. With the thumb press down the second thread on the left side of the guide, Fig. 18. This is continued until all the threads are crossed on the finger and thumb of the right hand. This cross is transferred to the pegs. When placed on the pegs B and C, it will be found that there is a crossing of alternate threads. The eight threads are now held

in one group and carried around the warping reel until the pegs at the other end are reached. The group of threads are carried over and under the pegs the same as was described with the warping board when only one or four threads at a time were warped.

Turning On, or Beaming

At the present time the warp is in a long chain ready to be placed on the loom in such a way as to make it possible for the weaver to produce a piece of cloth. To do this the ends at E must be attached to a roller, (in this case the warp beam) and spread out and wound evenly and tightly upon it. The warp beam fits into the back of the loom frame, as shown in Fig. 20.

For demonstration, suppose that the cloth to be woven is 22 inches wide and there are to be 24 threads to each inch. The warp then contains 528 threads, and this number is made up of 66 groups of eight threads each. It will be remembered that count was kept of the groups by means of the cord or tape between the pegs D and E while the warping was in progress.

The Warp Spreader (Raddle)

Fig. 21 shows a working drawing of the spreader, also called raddle.

Fig. 22 shows the drawing of the finished spreader with the top removed.

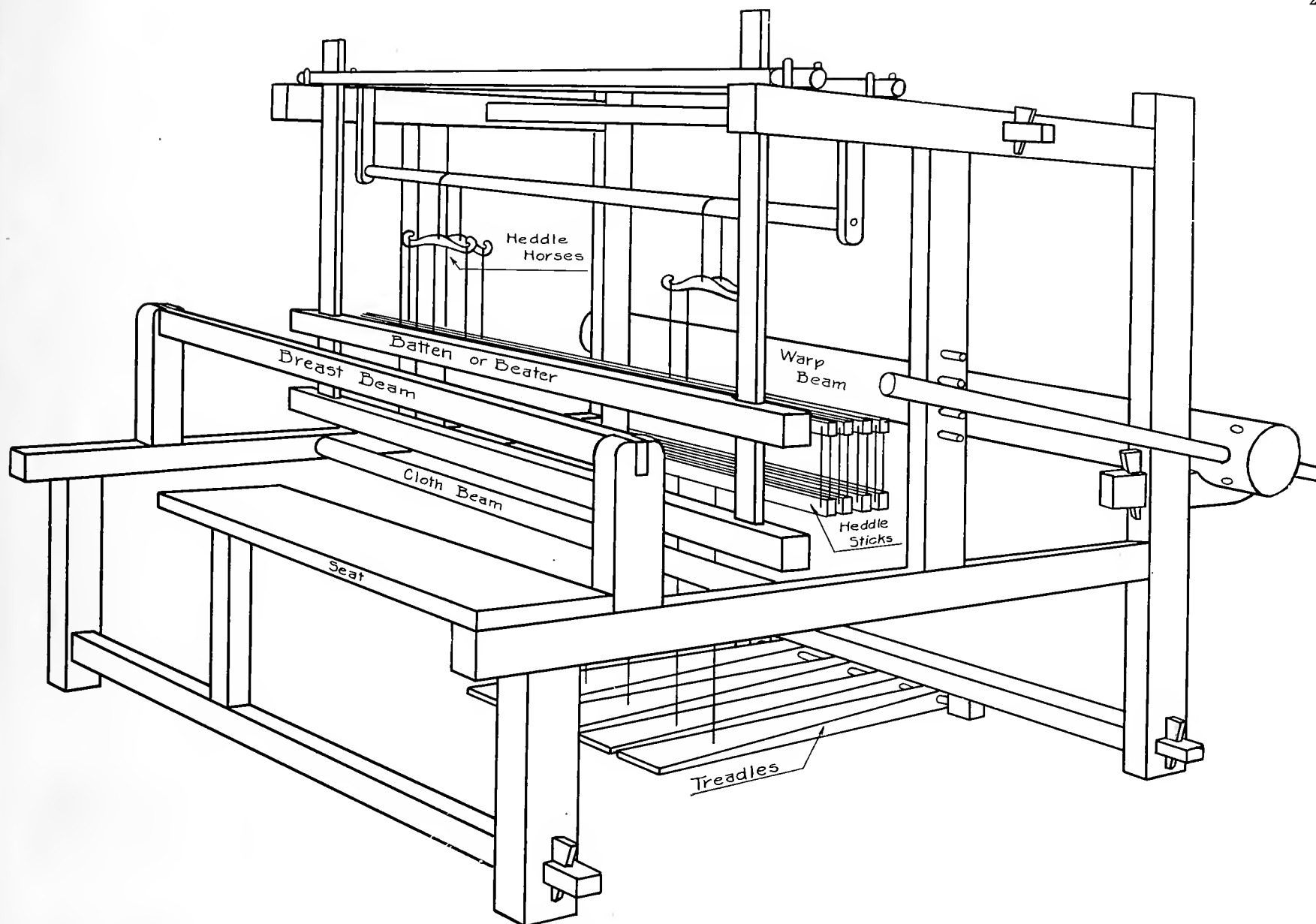


Fig. 20—Loom with Parts Named

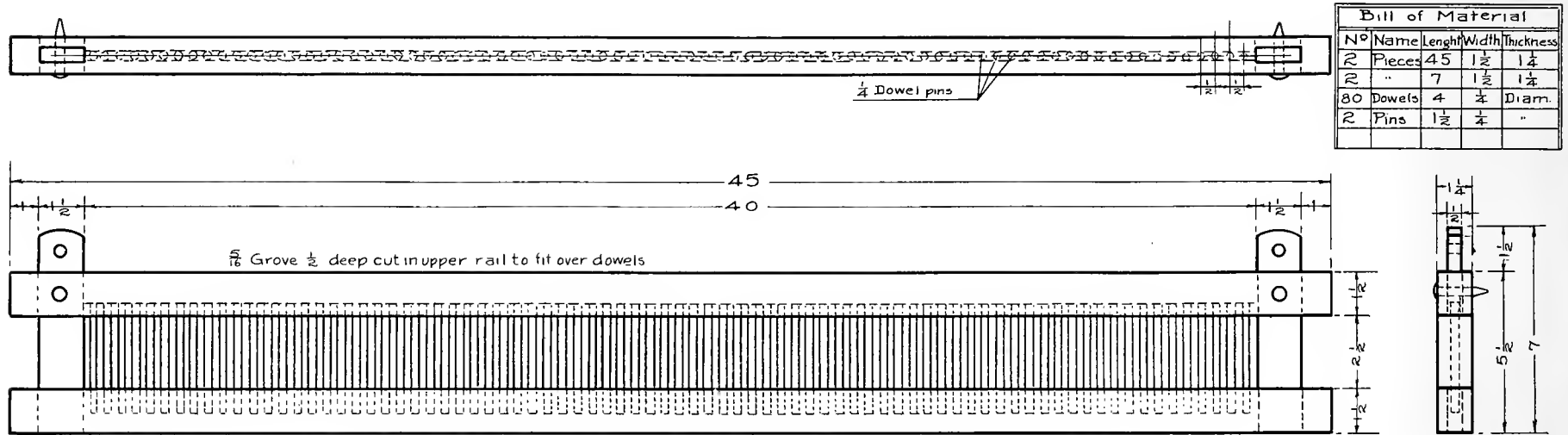


Fig. 21—Working Drawing of Warp Spreader or Raddle

The spreader is most simply described as a comb, with a movable cap to cover the ends of the teeth. The frame is made of wood. The teeth may be made of dowel rods or hard wire. Nails have sometimes been used.

The cap is deeply grooved above the teeth and has holes near the ends. Through these holes the sides of the frame pass in order to fix it on, as shown in Fig. 22.

A loom fully equipped has in the equipment a

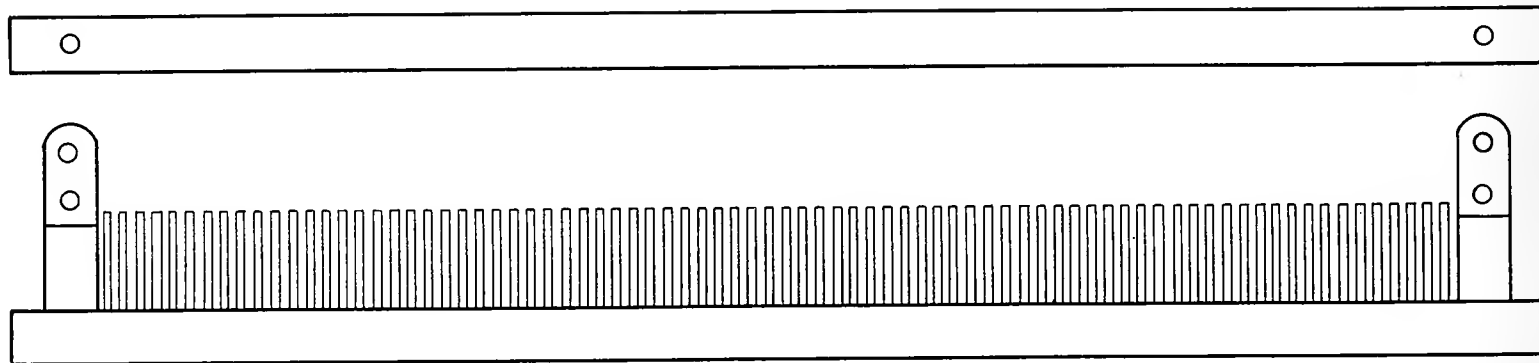


Fig. 22—Warp Spreader with Cap Removed

couple of rods, one to be used in placing the warp on the beam.

With the chain at hand and taking the end which when on the reel was between D and E, push a rod through the opening marked "A," Fig. 23. Untie the cord which held the cross and allow it to remain on the other side of the crossed threads, as shown in B, Fig. 23. Tie the ends of the cord to the ends of the rod, as shown in Fig. 23, C and D. By so doing the cross is retained. The rod may now be tied to the warp beam. A provision is always made for this tying. In the old colonial looms, holes are bored; the same is true of the Swedish type, while the Danish looms have a groove ploughed in the beam from end to end into which a smooth wooden or metal stick is placed to hold the warp to the beam.

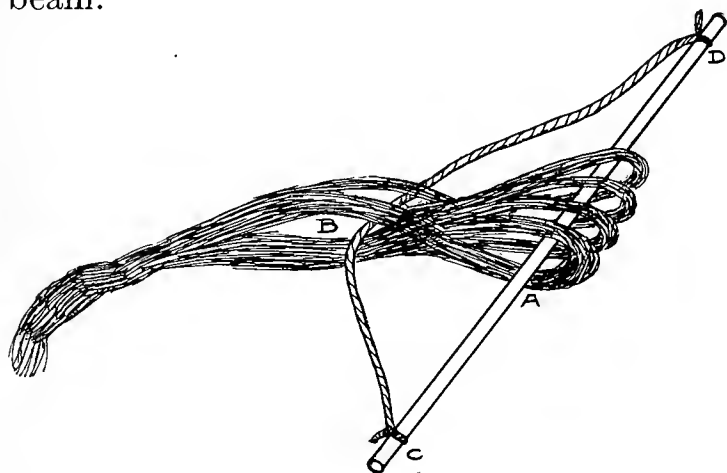


Fig. 23—Method of Keeping the Cross

From the front of the loom remove the beater, sometimes called the batten, the breast beam and the harness, Fig. 20. This makes a free opening from the front to the warp beam.

Tie the rod shown in Fig. 23 to the warp beam with No. 16 blocking twine. This fastens the chain to the beam, but in order that it may be placed on the beam evenly the groups of thread must be distributed in the warp spreader. Place the spreader under the chain and on a level with the warping beam. To hold the spreader in this position it may be tied to the upright parts of the loom, or it may be held by two persons, one at each side of the loom. Fig. 24 shows the spreader in place. With the top of the spreader removed the groups of thread may now be distributed in their regular order. Since there are 528 threads in all and eight threads in each group, there will be exactly 66 groups. There are to be 24 threads to each inch. This means that three groups of eight threads must be placed to the inch. This will occupy three spaces on the spreader.

By means of the cross the groups of thread may be used in their regular order and placed in the spaces of the spreader. When this is completed the cap is placed and fastened, and the warp is ready to be beamed.

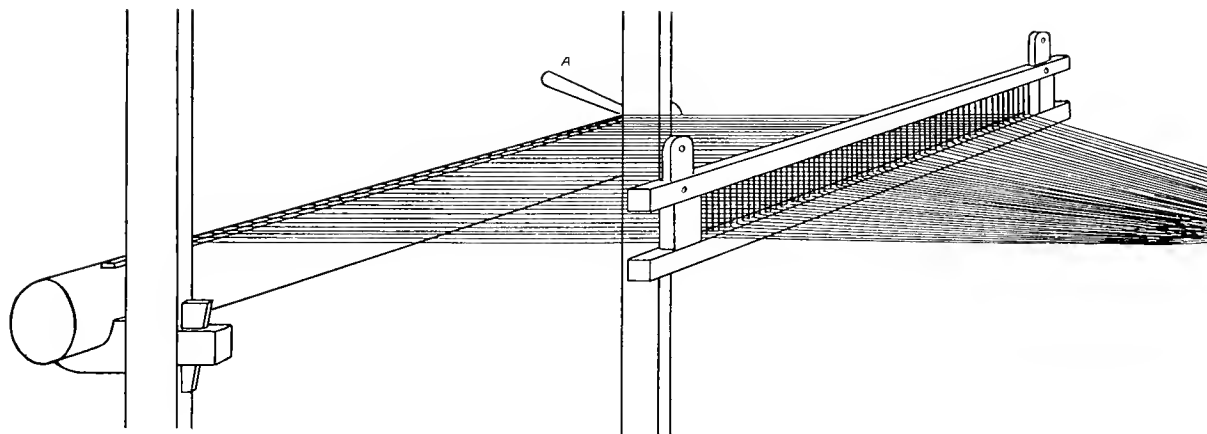


Fig. 24—Spreader in Place on Loom

One person holds the chain and the other turns the beam, by placing a peg into one of the holes at the end of the beam, as shown at A, Fig. 24.

Laying in Sticks

As the warp is being wound on to the beam, thin strips of wood about 3-16'' in thickness are laid on the beam for the warp to wind on. This prevents the warp from becoming tangled and also keeps the warp even across the entire beam. Strips such as are used in the bottom of shades are good for this purpose. After four or five yards of warp are wound on to the beam, lay in more strips.

A stand may be made to hold the spreader, as shown in Fig. 25. Fig. 26 shows the warp distributed. After the warp is distributed the cap is placed, thus holding the groups of threads securely

in their proper spaces. The spreader, warp, and all may now be transferred to the loom, and the warp may be put on as above described.

The beam is turned until the other end of the chain or warp is reached. Care should be taken to

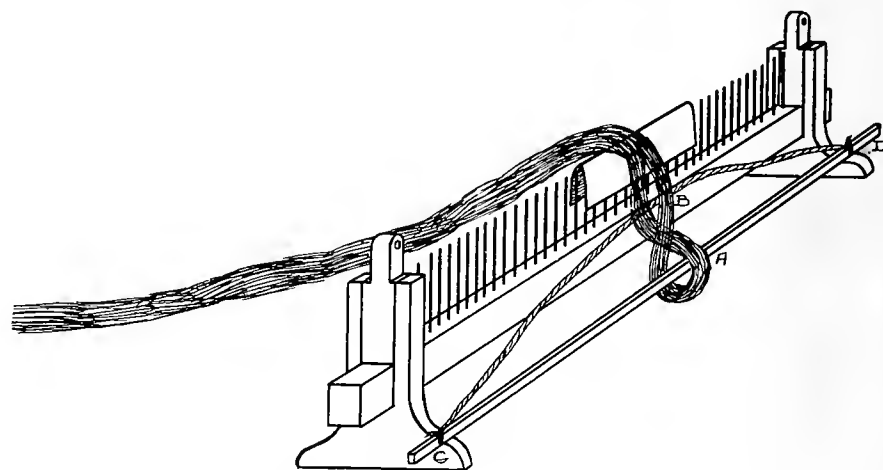


Fig. 25—Stand to Hold Spreader

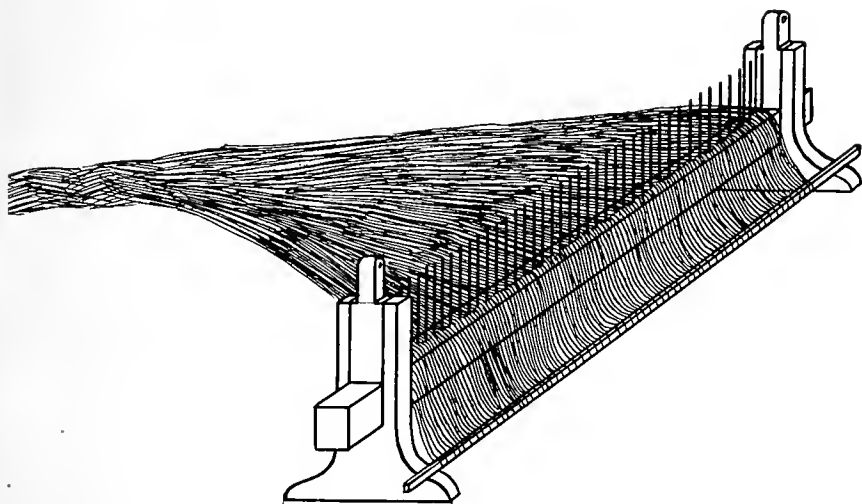


Fig. 26—Warp Distributed

hold the warp firmly while the winding is done. The chain unravels as it is wound on to the beam. When the opposite end is reached the cross which was so carefully guarded at the pegs A, B and C is reached.

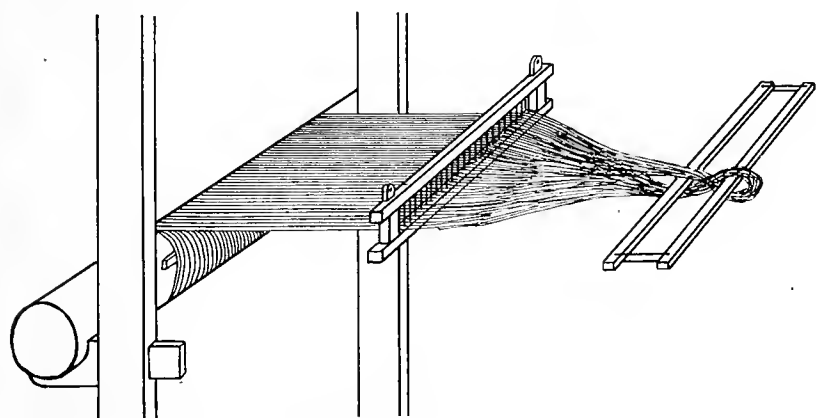


Fig. 27—Lease Rods in Place

Into these openings the lease rods are placed, as shown in Fig. 27.

The warp spreader may now be removed.

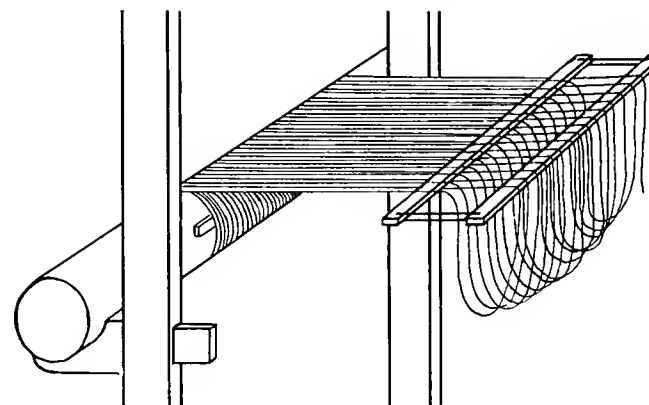


Fig. 28—Loops Hanging Over Lease Rods

Later the loops are cut, causing the ends to hang instead of the loop, as shown in Fig. 28. These ends may be tied in bunches in a loose knot, thus preventing them from losing their places in passing under and over the lease rods, Fig. 31.

Knottting the Heddles

The warp placed on the beam, it now becomes necessary to consider the knotting of heddles or leashes, as they are sometimes called. In order that each heddle may be of exactly the same size, a heddle frame is constructed about 12 inches by $1\frac{1}{2}$ inches by 3 inches, shown in Fig. 29. The pegs are numbered a, b, c and d. About $1\frac{1}{2}$ " from each end a peg

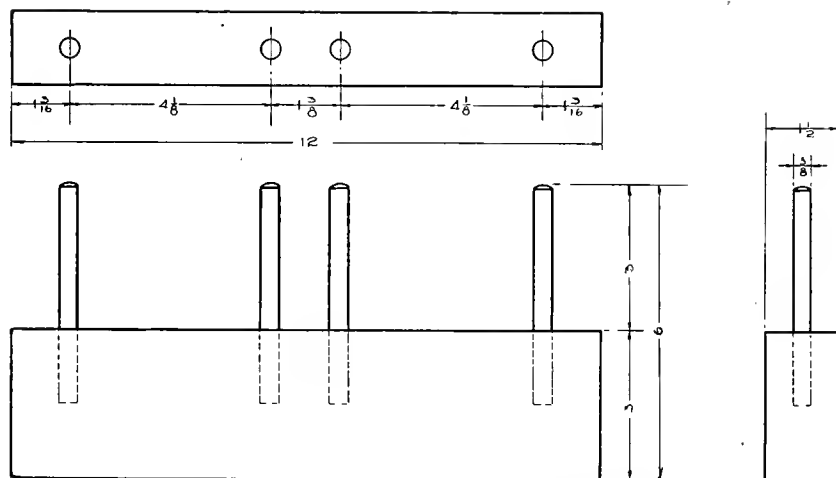


Fig. 29—Working Drawing of Heddle Frame

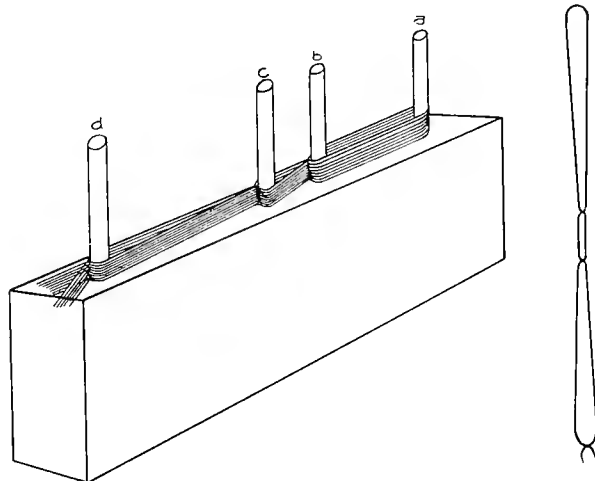


Fig. 30—Method of Tying Heddles

is placed and in the center two pegs are placed one inch apart, Fig. 30. The pegs should be rounded at the top and well sanded to make them perfectly smooth, thus causing the heddles to slip off easily.

The ordinary four-ply carpet thread is a fairly good material to be used in heddles. Sometimes linen thread is used and sometimes a hard twisted cotton, called seine twine, used in fish nets, is utilized. The twine is cut long enough in order that it may be looped around a, Fig. 30. Tie a knot at b and another as shown in c. The ends are then tied at "d." From 25 to 50 may be tied before removing them from the pegs. There must be as many heddles as there are threads in the warp. Heddles found in the market are made of wire. These may be successfully used.

Heddle Sticks

In most foot-power looms the heddle sticks are used instead of the heddle frames. Fig. 31 shows, at A, heddles on the sticks. The harness, which consists of the various heddle sticks on which the heddles have been placed, is now hung in the position as shown in Fig. 31. The person who is to do the threading sits in the front of the harness.

Threading the Loom

The harness consists of two sets of heddles, one directly back of the other, as shown in Fig. 31.

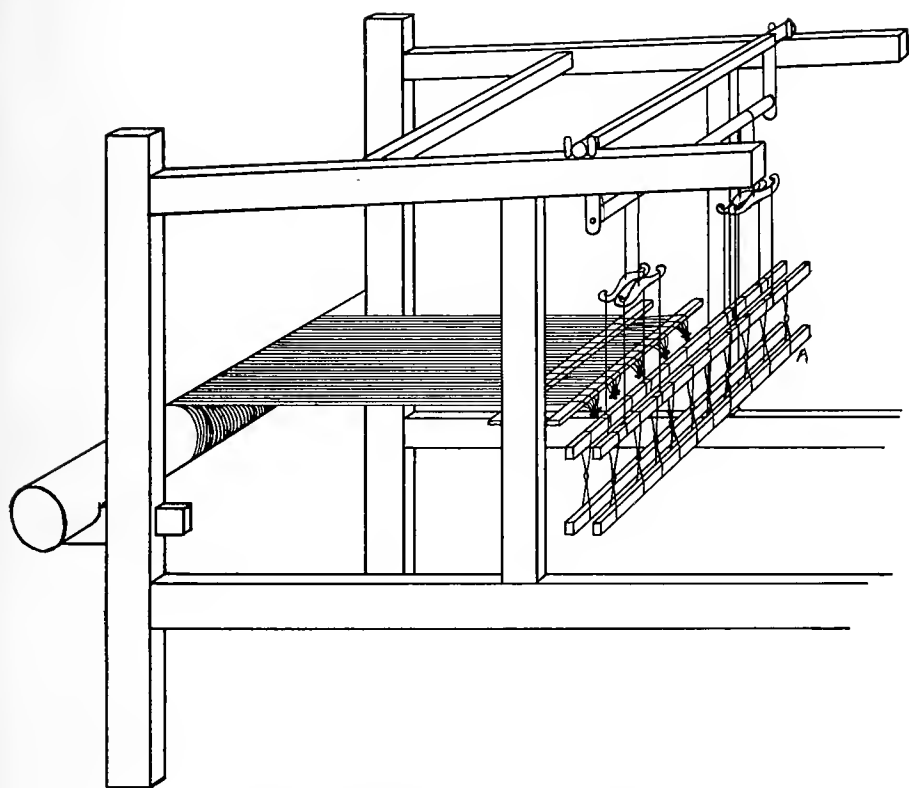


Fig. 31—Heddles in Place for Threading

The threading of the first loom will be for plain weaving, such as may be used in rugs. The one who is to thread the loom has comfortably seated himself in front of the harness in Fig. 32. First a heddle on the front sticks is pushed along. The first thread is picked up and the end is threaded through the eye left for this purpose in the heddle. A heddle is now taken from the back sticks and the second thread is picked up and placed in the eye of

the heddle. After being threaded it is pushed along, another heddle from the front sticks is picked out, and the third thread is put through the opening. It now is pushed along and a heddle from the back sticks is picked out and threaded with the fourth thread.

This is continued until all threads have been used. The heddles must be so placed on the sticks that each one may be slipped along without interference from any of the others. When four threads pass over and under the lease rods at one time the threads should be taken in their regular order as nearly as possible. Four threads going either over or under are threaded before taking the next four. If the threads are crossed, as shown in Figs. 18 and 19, one passing over and the other under the lease rods, they are threaded in their regular order.

Threading the heddles is of the greatest importance, as one mistake will throw out the whole succession of remaining threads. If the heddles are of string the threading may be done with the fingers only, but if the heddles are of wire it will require a heddle hook to draw the threads through the eyes.

The Reed

The reed is the long comb-like piece of apparatus which fits in the beater or batten and aids in pushing or pressing the woof in its proper place, Fig. 33. The spaces in the reed are usually termed "dents."



Fig. 32—Threading the Heddles

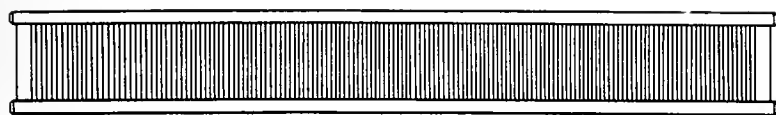


Fig. 33—The Reed

Reeds are sold by number. For instance, a number 12 reed means that there are 12 openings or dents to the inch. A number 15 reed means that there are 15 dents to the inch, etc.

Threading the Reed

The threads having been drawn through the heddles are now ready to enter the dents of the reed and must again enter in their regular order. The threads must not be allowed to cross one another. In ordinary rug weaving one thread enters each dent. To do this the reed is hung just in front of the harness, as shown in Fig. 34. By means of a reed hook the threads are drawn through the dents in their regular order, care being taken to use each dent. If a selvage is desired two threads at one time are drawn through the first four and the last four dents of the reed. The reed is often longer than the cloth to be woven is wide; when this is true, plan to have the threads occupy the center part of the reed, leaving the surplus at each end. If a single dent should be omitted the weave cannot be perfect. The reed hook may be made of a piece of thin wood, as shown in Fig. 35. In threading the reed the hook

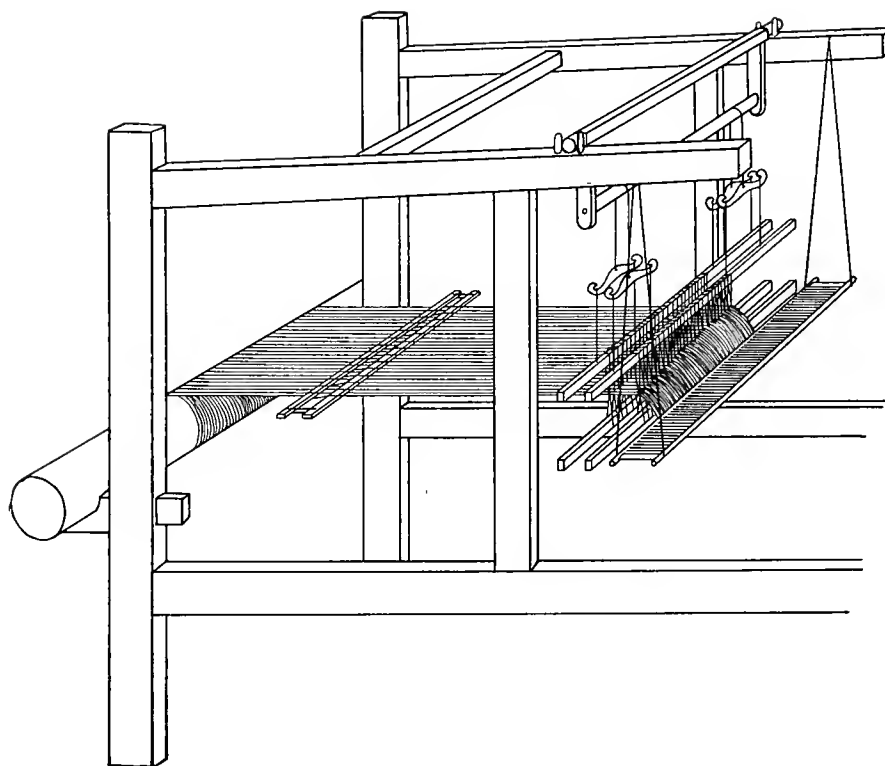


Fig. 34—Reed in Position for Threading

is pushed through the dents from below, catching the thread and drawing it downward through the opening. If the wooden hook as shown in Fig. 35 is used, it may be pushed into the dent from above, and the thread may be placed on the reed in such a position as to be drawn through when the hook is pulled from below. After a number of threads has been entered they are tied into a bunch. This is done partially for safety, as the reed may slip in

some way from its position and drop to the floor, thus causing the threads to slip from the dents.

Placing the Reed

For convenience in threading, the harness and reed are hung close to the warp beam, as in this

position the weaver can sit in a comfortable position while doing the threading.

The threading having been completed the harness and reed are brought forward. The batten is hung and the reed put in its proper place in the batten, as shown in Fig. 36.

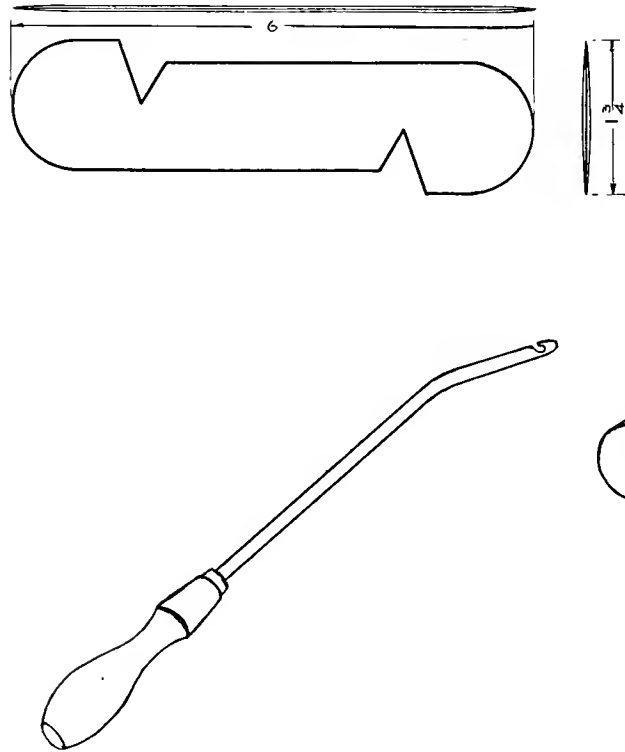


Fig. 35—Reed Hooks

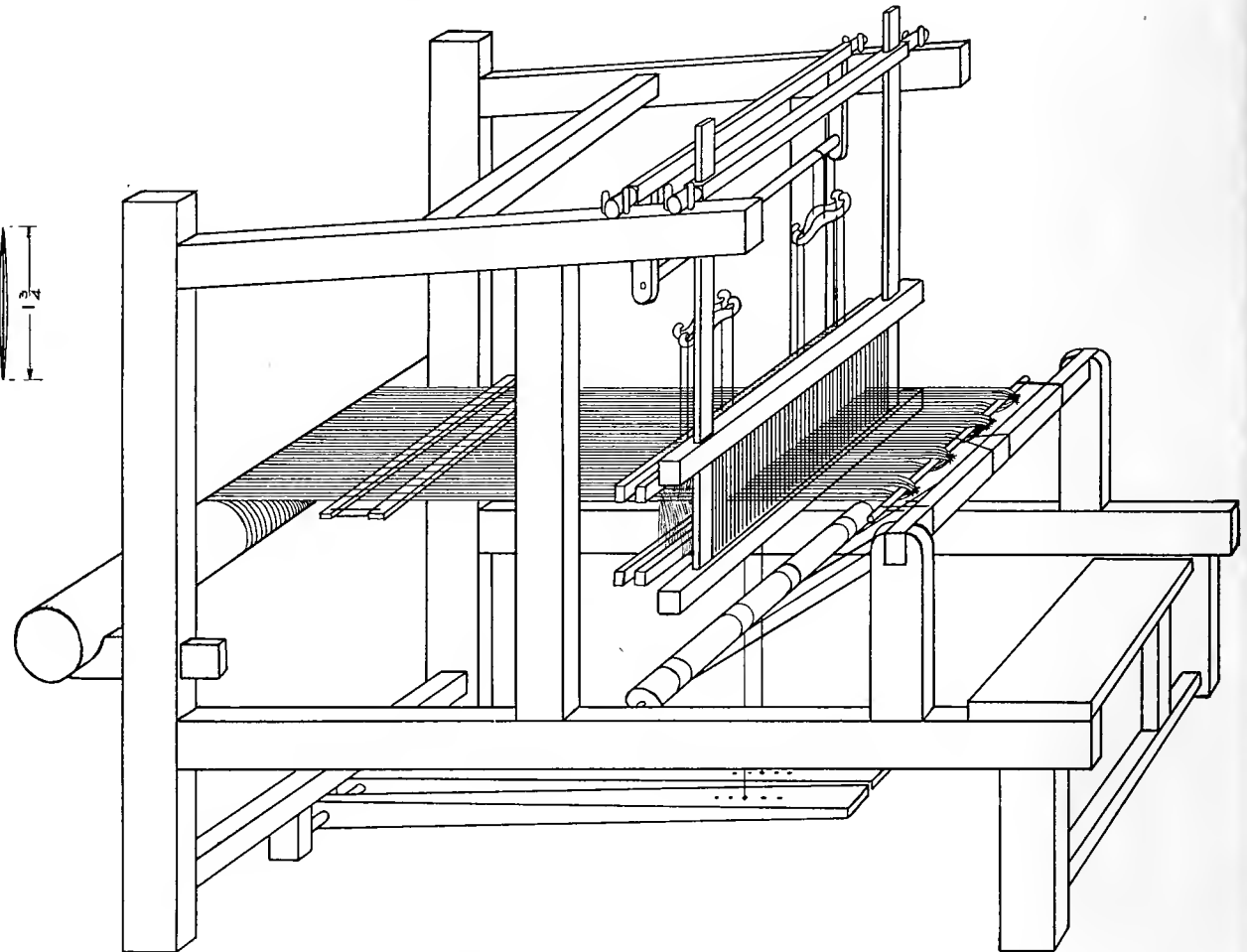


Fig. 36—Loom Ready for Tying Up

The loom is now ready to be "tied up." This process is called "gating the loom."

Tying the Loom

Before beginning the tying-up process it is of great importance that the weaver understand some simple way of using a slipknot, as the process of tying up requires a great deal of adjusting. It is usual to tie up with double cords, as these always terminate either in a loop or two ends, both of which are necessary for the adjustable slipknot. The loop for the slipknot is made at the end of the looped cord, as shown at A, Fig. 37. The finger and thumb reach up and grasp the double cord at "A," Fig. 38. The double cord is now drawn through the opening marked "B," as shown in Fig. 39. Through the loop thus made the two ends of the cord are passed, Fig. 40. Fig. 37, A, B, C, and D show in the successive steps the way the knot is made.

A shows simply the loop and ends.

B shows the ends drawn through the loop.

C shows the ends drawn through the loop and a single knot tied with them.

D shows the single knot tied and drawn down to the loop.

By using the above method for tying, the cords may be shortened or lengthened, as the case may be.

By pulling the two ends of the single knot the latter is drawn close to the loop. It will be found that the knot will not give way no matter what the weight of the pull may be. If the cord is to be lengthened the knot is loosened and the cord is adjusted.

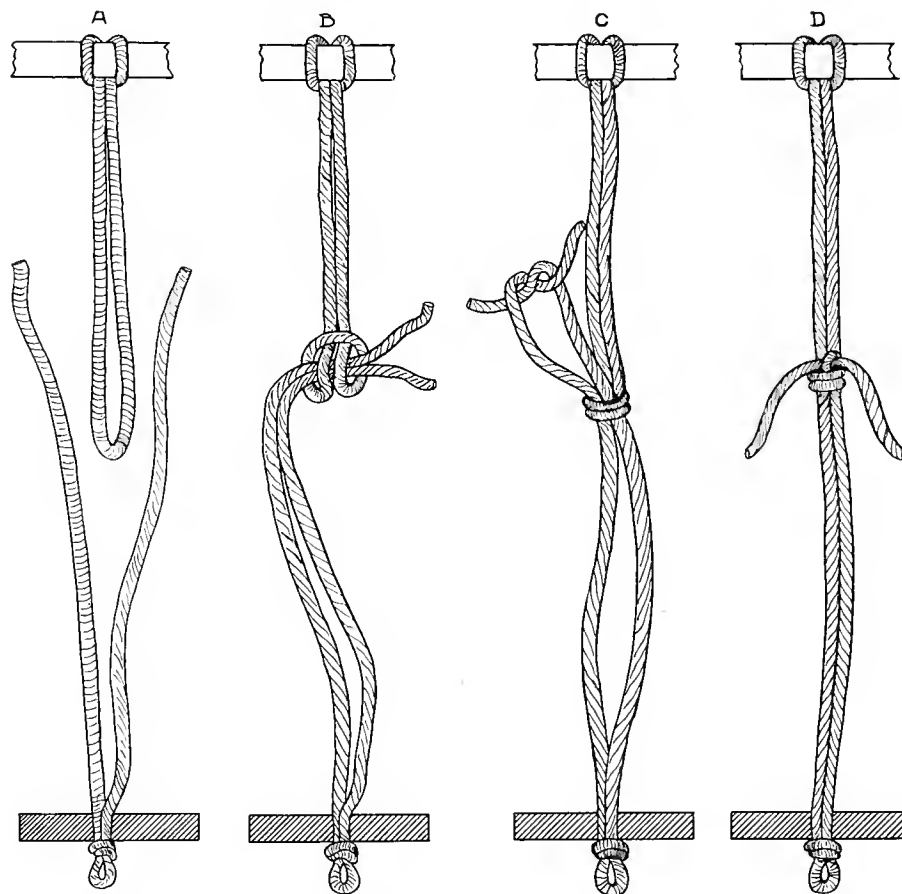


Fig. 37—Method of Tying Slip Knot

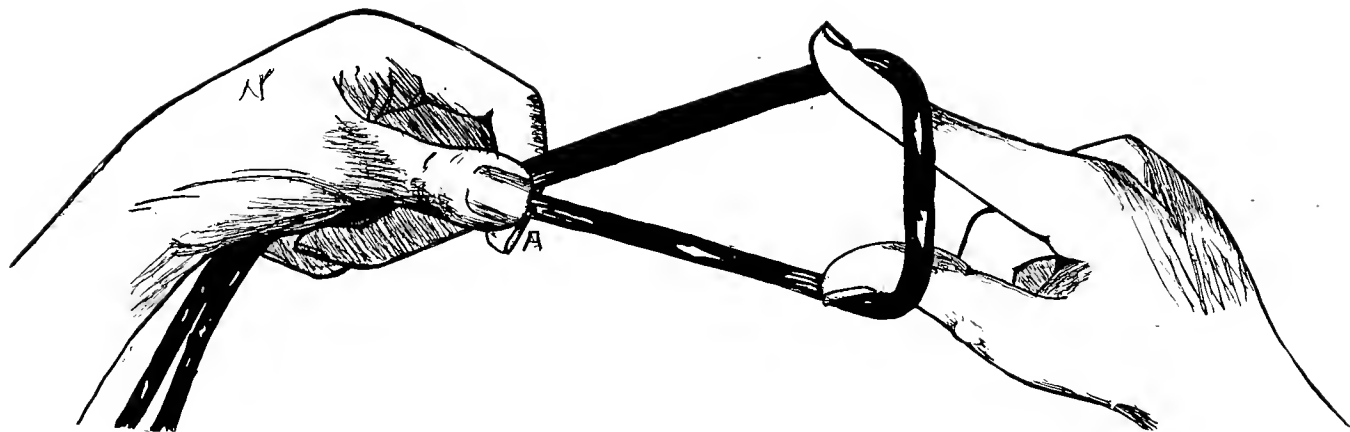


Fig. 38—First Step in Making Loop for Slip Knot

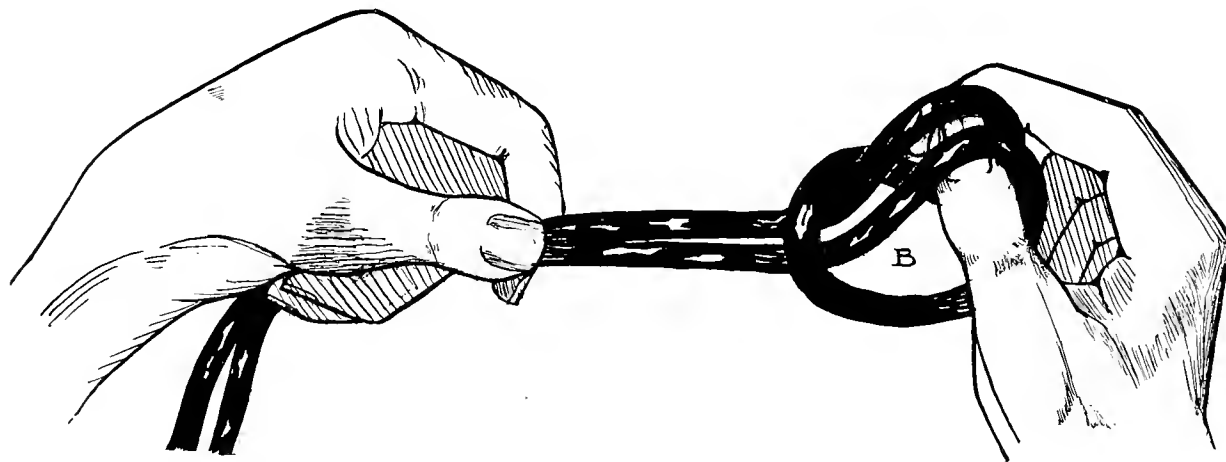


Fig. 39—Loop Completed

The harness, which is made up of the heddles and heddle sticks, hangs just behind the beater and is suspended by tying the heddle sticks to the heddle horses.

The heddle horses are tied one to one end of a piece of No. 16 blocking cord and one to the other. Fig. 41 is the drawing of a heddle horse. The rope is thrown over the roller just above, allowing one

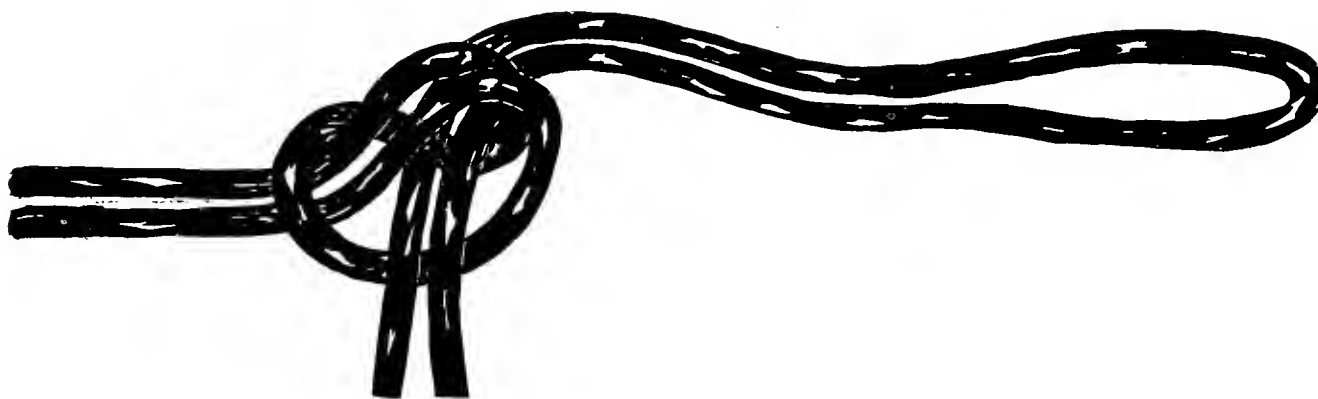


Fig. 40—Two Ends of Cord Placed in Loop

horse to hang to one side and one to the other. Two other heddle horses are tied and hung in the same way at the other end of the roller. Fig. 20 shows heddle sticks hung in the finished loom.

Cords are tied from the ends of the heddle horses to the top heddle sticks. From the center of

each lower heddle stick a loop of No. 16 blocking cord is tied. The ends of the cord extending from the treadles slip into the loop, extending from the heddle sticks, as shown in Fig. 42. When pressure (in this case the foot) is applied to a treadle the part of the harness tied to that particular treadle draws

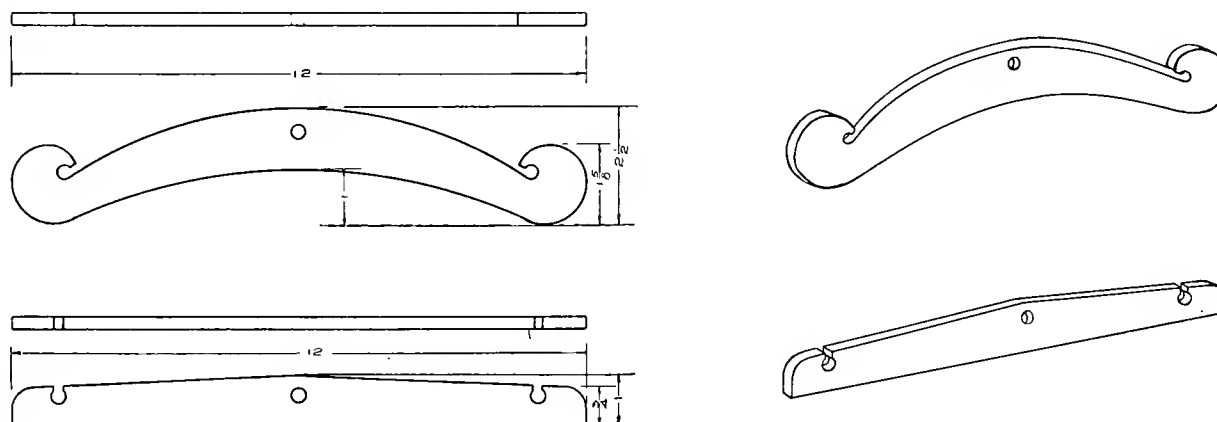


Fig. 41—Heddle Horses

the threads downward. Upon releasing this treadle and applying the pressure to the other treadle the other half of the threads are drawn downward.

The Cloth Beam

The ends drawn through the reed are now hanging loosely or tied in bunches in the front of the reed. These ends must in some way be connected with the cloth beam (Fig. 20). Holes have been bored through the cloth beam. Through these holes the No. 16 blocking cord is drawn.

Beginning at the right of the cloth beam draw one end of the cord through the first opening. The other end is tied to the end of a rod, which is as long as the reed.

(These rods were mentioned earlier in the process of warping. One was used in fastening the warp to the beam.)

The cord is now threaded through the next hole, which is No. 2 in the cloth beam, and then through hole No. 3.

A long loop is left between No. 2 and No. 3 and the rod is pushed through it. The cord is now threaded through hole No. 4 and tied to the other end of the rod, as shown in Fig. 43.

The cord is cut long enough to allow the rod to be brought up and over the breast beam up to the reed. The ratchet which connected with the cloth

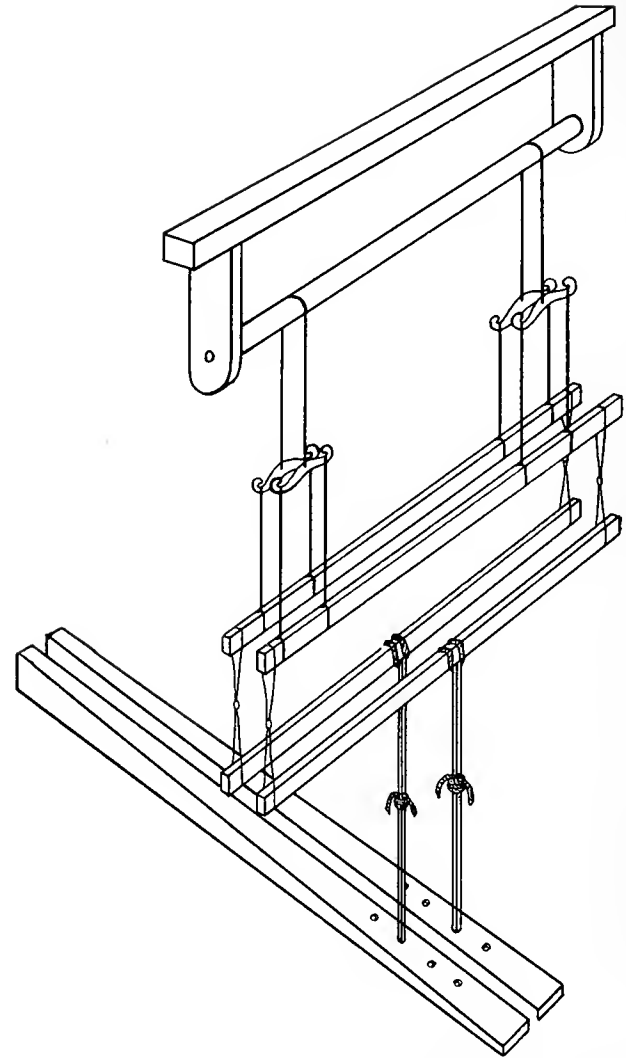


Fig. 42—Method of Tying Heddle Sticks to Treadles

beam is now turned, rolling on the cord until the rod is about 8 or 10 inches from the reed. The ends now hanging in bunches are untied. About 30

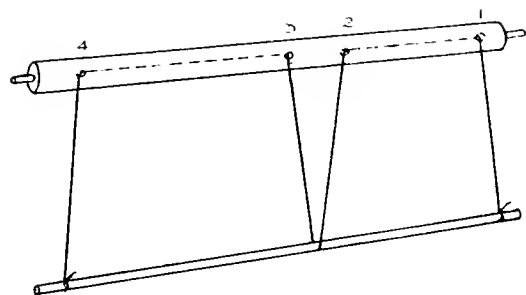


Fig. 43—Method of Preparing Cloth Beam

threads are held in one group. The group is divided, allowing one-half of the group to pass under the rod and the other to pass over the rod. With the ends of the groups tie a single bow knot over the rod. Take up another group, divide it, and tie the same way. Continue until all have been tied to the rod, as shown in Fig. 44.

The Shed

After the loom is "tied up" and the right treadle is pressed downward, all the threads which pass through the eyes of the heddles on the front heddle sticks are pressed downward, thus causing a space between the threads passing through the front heddle eyes and those passing through the back heddle eyes.

This space comes just in front of the reed when the beater is swung back, as shown in Fig. 45.

This space is called the "Shed," and it is through this opening that the woof is passed. The woof once in place, and the treadle released, the beater is

swung to the front, thus by means of the reed the woof is pressed in place. The left treadle is now pressed downward, and the woof again passes through the shed from the left, the beater and reed pressing it into place the same as in the first thread.

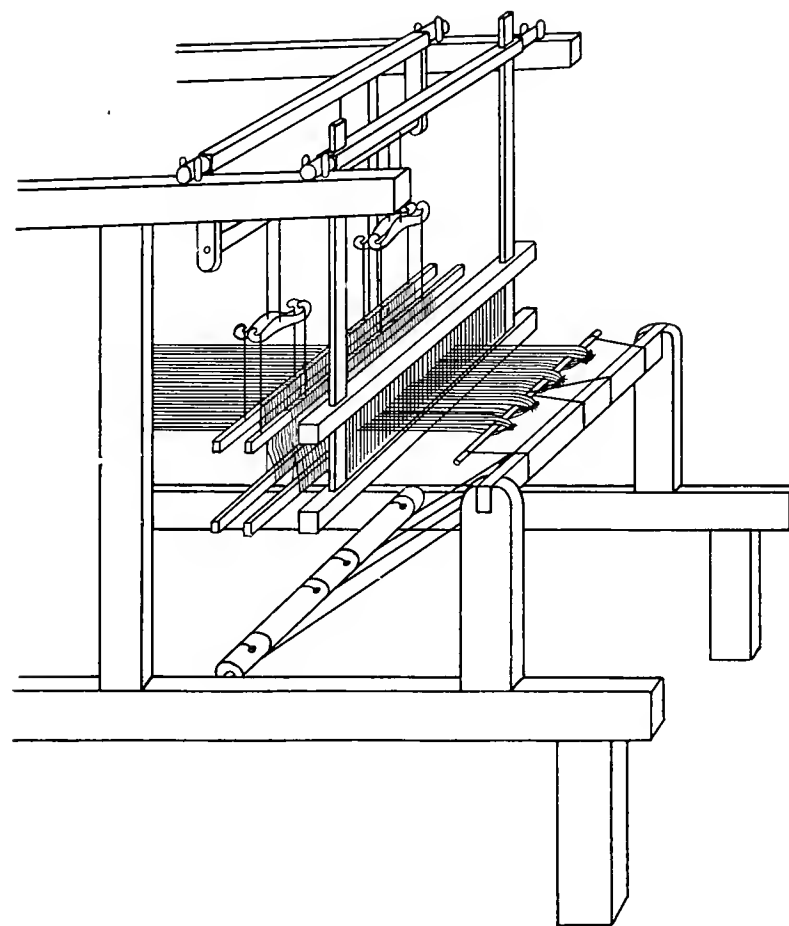


Fig. 44—Warp Tied to Cloth Beam

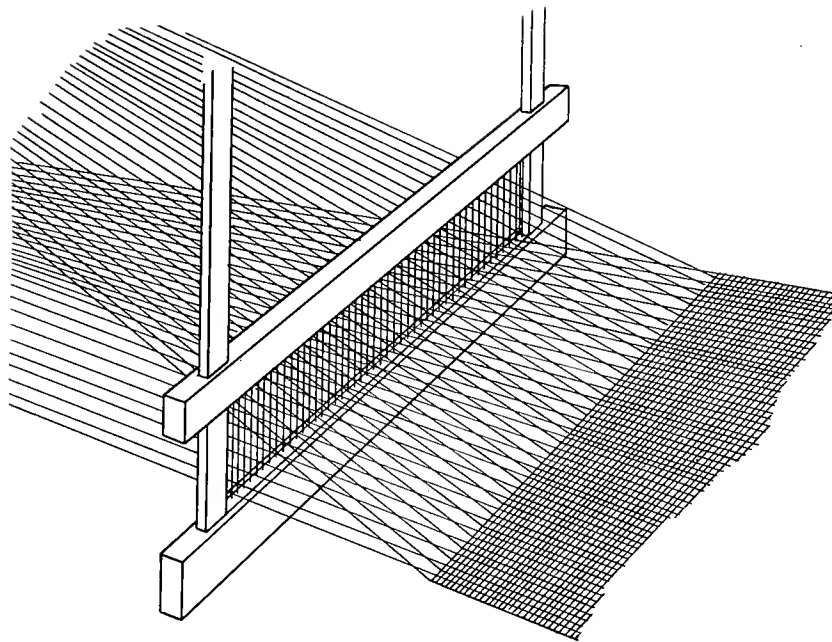


Fig. 45—The Shed

If rags or similarly heavy materials are used, they are wound on what is called a shuttle which in this case is simply a piece of quarter-inch bass, poplar, or pine, cut as shown in Fig. 45. If finer materials such as mercerized cottons are used, a shuttle similar to the one shown in Fig. 46 is used.

The Small Shuttle

The beginner will, no doubt, use principally the coarser materials for the woof and will, therefore, use the shuttle as shown in Fig. 46 and Fig. 46a.

The shuttle shown in Fig. 46a is so constructed as to admit of a piece of 10 or 12-gauge wire. This wire extends lengthwise across the inside of the

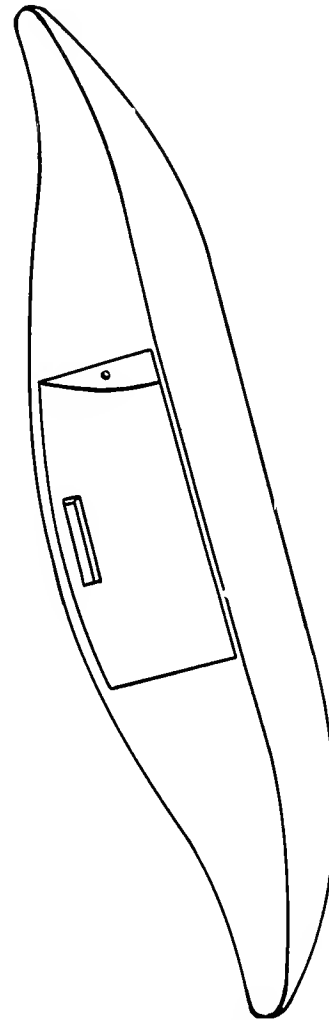


Fig. 46—Small Shuttle

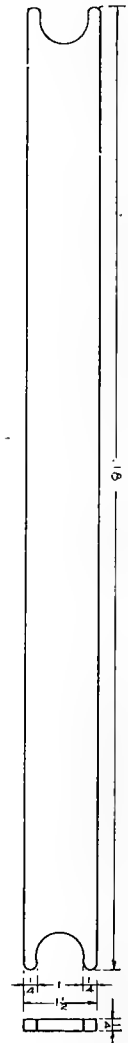


Fig. 47—Shuttle Stick

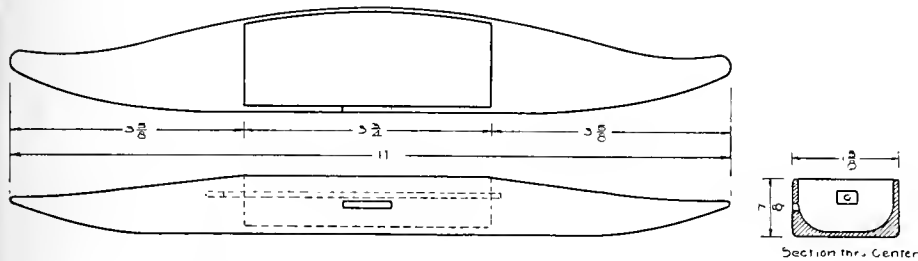


Fig. 46a—Working Drawing of Small Shuttle

opening, the ends being forced into two little holes, one in each end of the opening. In one of the holes, a small spring is concealed and the wire is put in place very much as a bobbin is placed into the shuttle of a sewing machine. Fig. 47 shows a shuttle stick.

Bobbin Winder

Fig. 48 shows a bobbin winder extensively used in Norway and Sweden. Small wooden spools are slipped on to the shaft of the winder, or a piece of paper may be tightly wrapped around the shaft. The end of the thread to be wound is caught in the wrapping of the paper. By means of the small crank the wheel is turned and the thread is wound on the spool or paper. The bobbin is made in this way. If the bobbin winder as shown above is not available, a spinning wheel may be equipped to do the work. A plug with an extension may be forced into the spindle, as shown in Fig. 49. The spool or the paper may be wrapped around this extension, and the wheel may be turned just as when spinning.

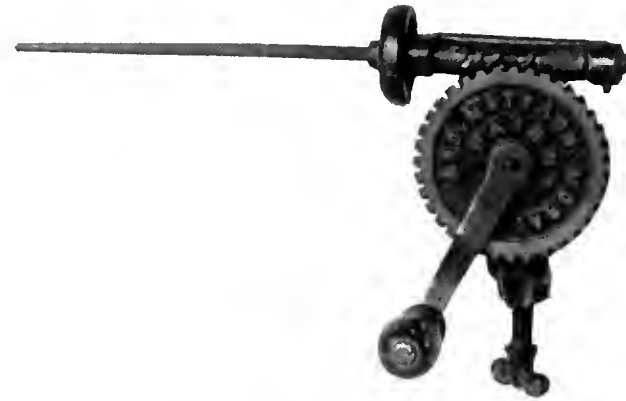


Fig. 48—Bobbin Winder



Fig. 49—Spinning Wheel Used for Bobbin Winder

The Temple

As the weaving continues, it will be found that there is a tendency in the fabric to "draw in" narrower than the entering of the warp in the reed. When this "drawing in" becomes noticeable, it may be corrected by using the temple.

The temple is very simple in its construction. Fig. 50 shows the working drawing. At the broad ends of each of the parts, $1\frac{1}{2}$ " or 16-gauge brads are driven in and the heads are filed off. For heavier material, the brads should be of 12 or 14-gauge.

The parts when joined together are for the purpose of holding out the edges of the material being woven, to the required width. The means of adjusting the length of the temple are shown in Fig. 51 and Fig. 52. The parts are held together by a wire nail or wooden pin, which is forced into the holes bored thru the sides of the parts.

The pin is first inserted and the temple placed on the cloth a short distance from the reed, with the filed points of the brads catching the edges of the material, as shown in Fig. 52. When the temple is

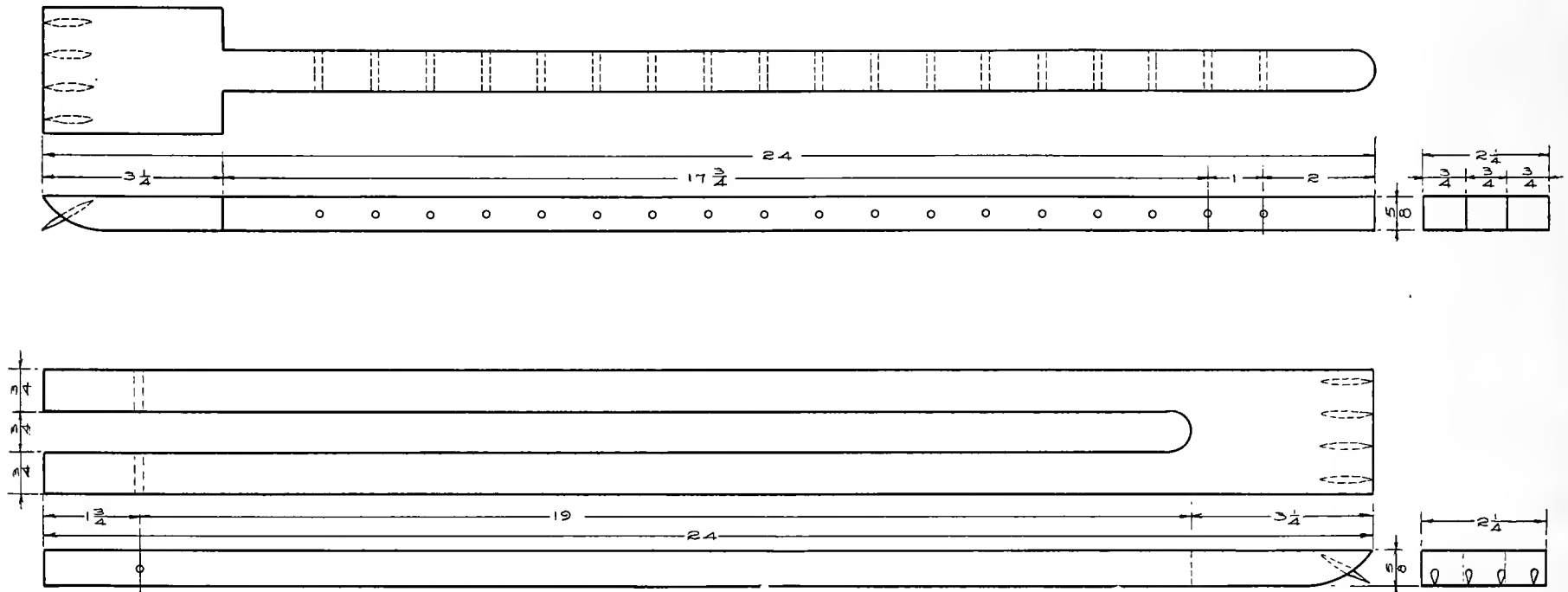


Fig. 50—Working Drawing for Temple

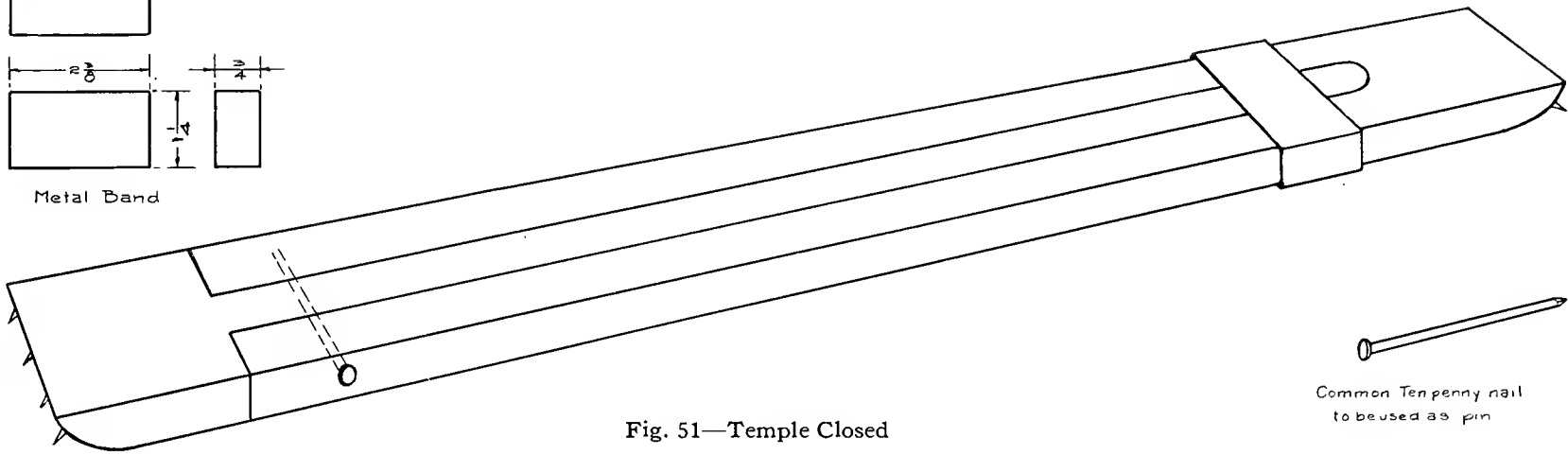
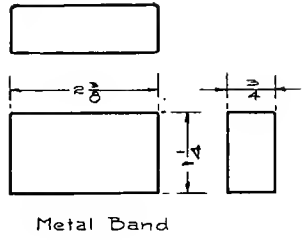


Fig. 51—Temple Closed

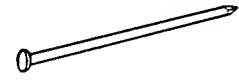
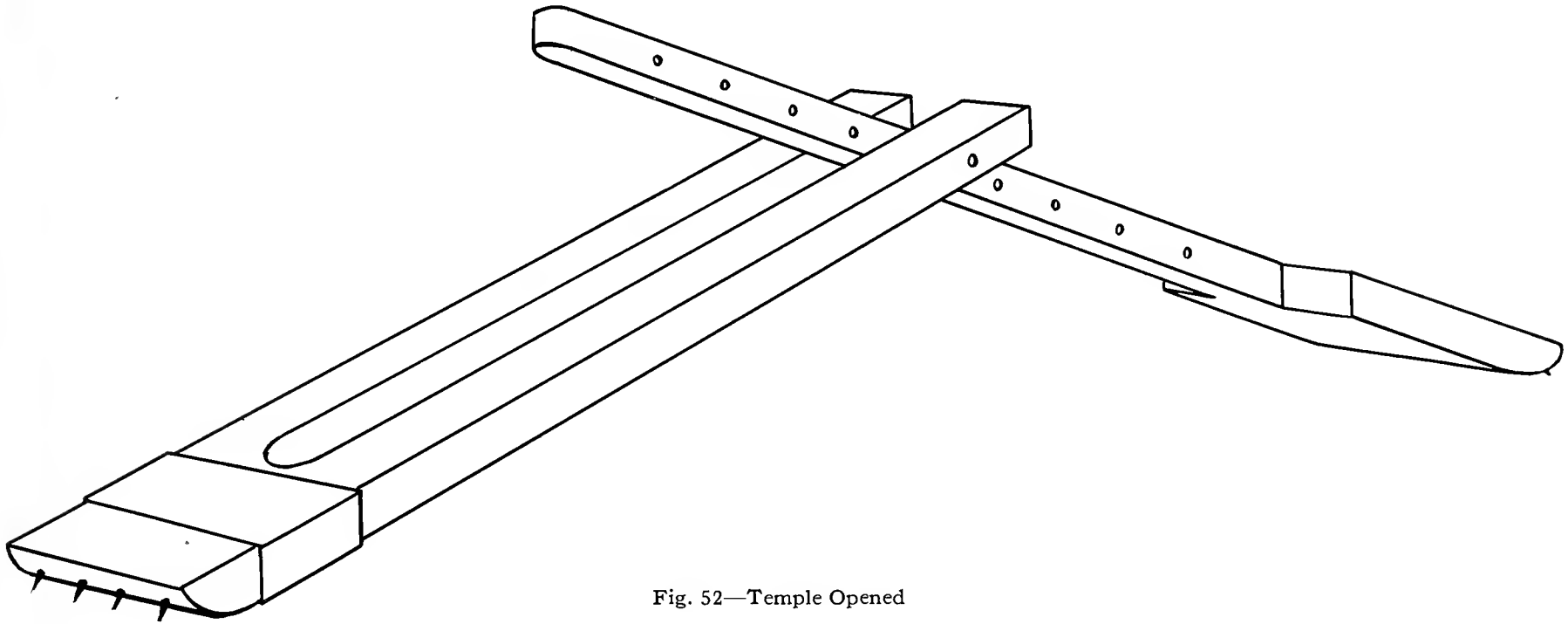
Common Tenpenny nail
to be used as pin

Fig. 52—Temple Opened

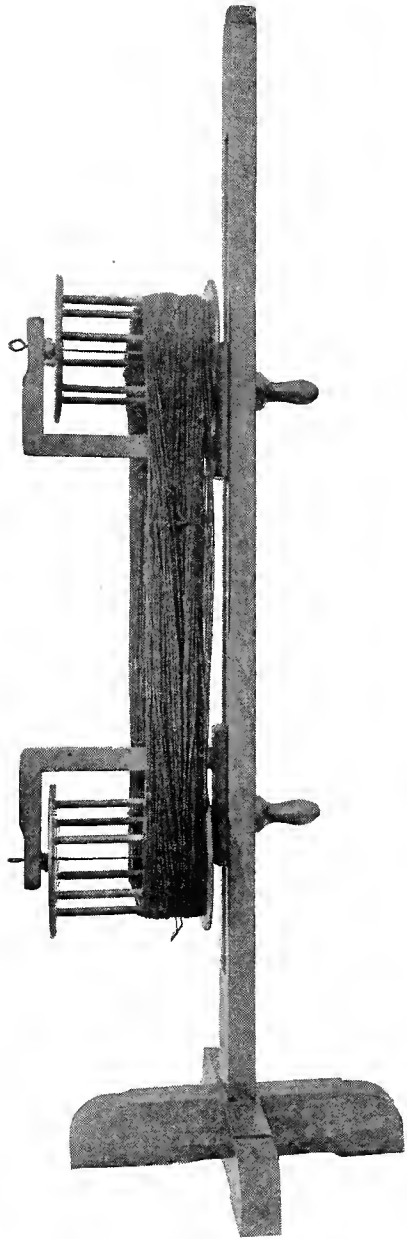


Fig. 53—Pair of Reels



Fig. 55—A Reel or Swift

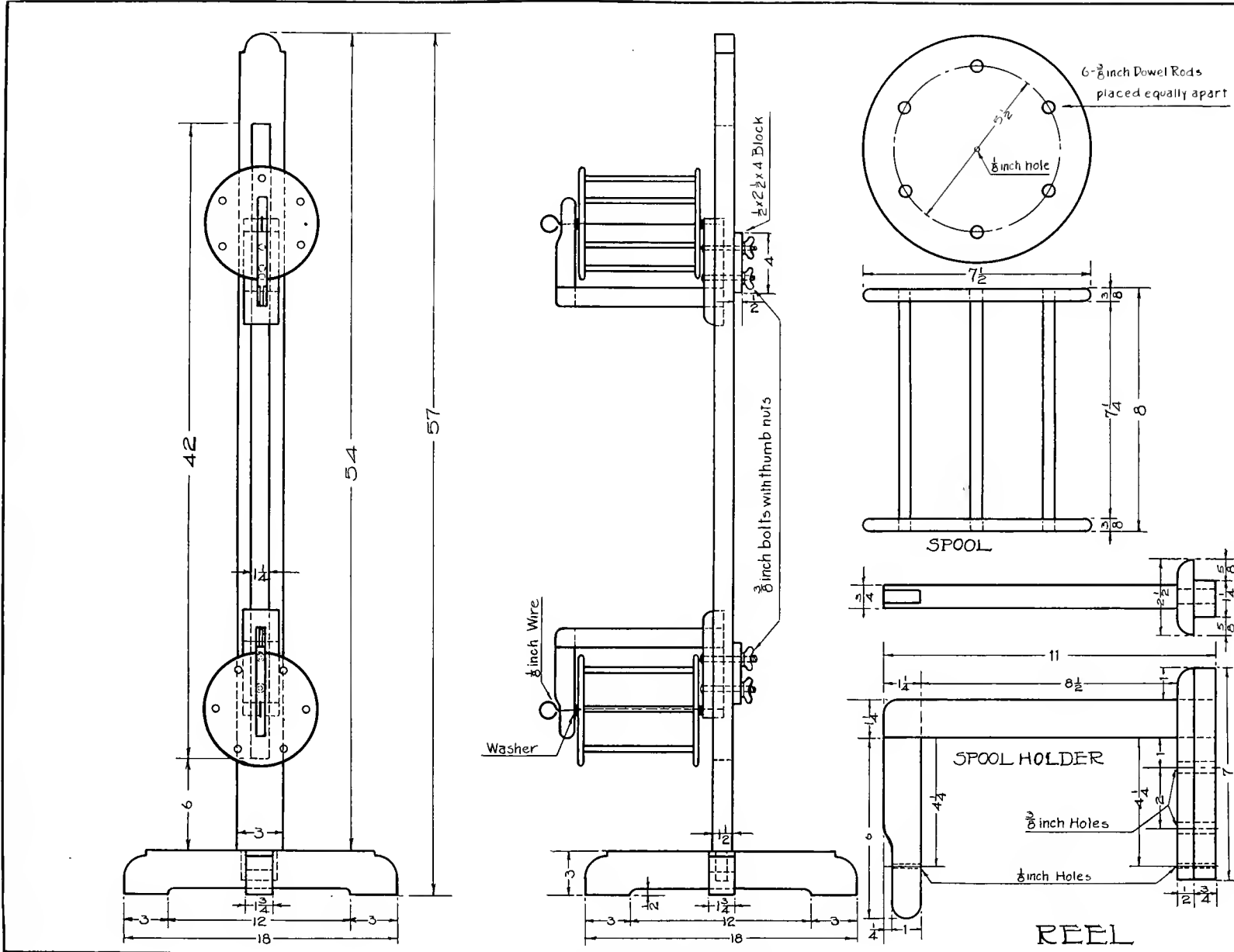


Fig. 54—Working Drawing of Reel

pressed down in this position, it will force out the edges of the cloth. The small metal band "A," which fits closely, is moved along so it holds the two parts together. After weaving from four to six inches, the temple is moved so it again is a few inches from the reed.

To move, slip the metal band so the parts may swing on the pin and proceed as above described.

The Reel

A great many of the different threads used in weaving must be purchased in skeins. This fact makes the reel almost indispensable, in order that the skeins may conveniently be made into bobbins.

Fig. 53 shows a pair of reels, mounted on a

stand in such a manner that the distance between them can be regulated. Fig. 54 shows the working drawing of a pair of reels. It will be observed that the upright of the stand has a slot cut in it for the greater part of its length. The reels revolve on elongated axles, and may be fixed in the slot at any height, by means of a screw and collar. This makes it possible to adjust them to different-sized skeins.

Fig. 55 shows another kind of reel which may be fastened to a table. It opens like an umbrella and may be adjusted to skeins of various sizes. The small skein allows only a partial opening of the reel. The skein is placed over the reel while closed. The reel above mentioned is often called a swift.

CHAPTER II

Pattern Weaving

Rag Rugs

In weaving rag rugs the loom must be threaded with a four-ply carpet warp, twelve threads to the inch. This calls for a number 12 reed. Since the process of preparing the loom has already been described in detail, the weaving may at once begin.

Figures 56 and 57 show what may be done with rags. The design is kept in straight and unbroken lines. Figs. 58 and 59 show what may be done by laying straight pieces of cloth to cover the color used in the body part. In this case the design is also kept in straight, unbroken lines. The material used in the light colored rugs is unbleached muslin, while the colored borders are of blue outing flannel. The dark rug is of Dutch blue calico and unbleached muslin.

Introducing Color as shown in Figures 58 and 59

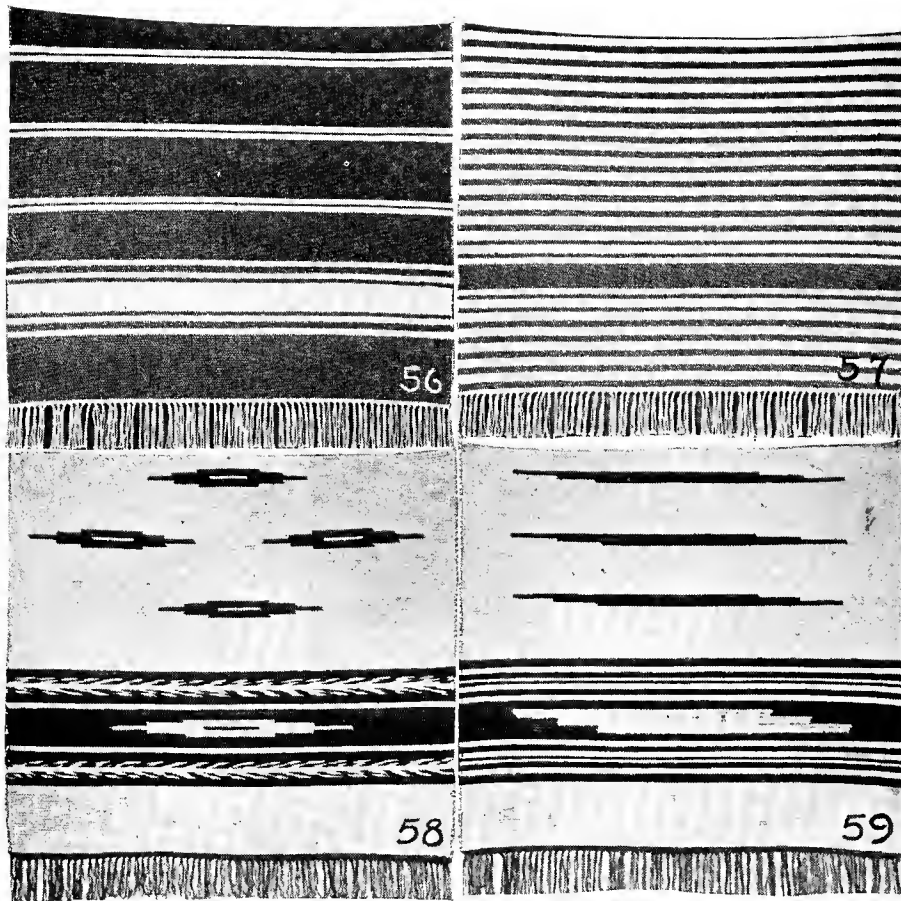
The cloth used for the foundation is drawn through the shed and beaten. The beating presses

the strip of cloth together. Without crossing the threads, draw in the short pieces to be used for the design and wrap them around the color used for the foundation. To make this as easy as possible the foundation strip just beaten may again be pushed out into the shed so that it may easily be wrapped with the color used in the design.

After the colored strips have been wrapped around the foundation color, the beater is drawn forward and presses the foundation color with the strip in the design into place.

This process is a most interesting way of introducing color when the coarser materials are used.

Before beginning to design for loom work, it is better to operate the loom and know just a little of its possibilities. When this plan is pursued the designs made are usable, as the operator knows what is possible and will design accordingly.



Figs. 56, 57, 58, 59—Woven Rag Rugs

Plaids

Figure 60 shows a series of simple yet effective plaids which may be woven on a two-harness loom. In reeling the warp for plaids, a certain number of threads of each color are reeled according to the

desired plaid. When the reeling is completed and the warp is placed on the warp beam, it will be found that the warp is in bands of color.

In weaving the finished cloth the same colors as were used in the warp are now used in the woof. If ten threads of a certain color were used in the warp then the same number of threads of the same color must be used in the woof. It is in that way that the plaids are made.

Pattern Weaving

To the casual observer of hand-woven articles, nothing seems quite so impossible as many of the complicated patterns woven on the ordinary foot-power loom. To those who have done weaving, the pattern work does not seem so wonderful. It is surprising how quickly the amateur weaver grasps the idea of pattern weaving.

The plan here is to present the pattern weaving in the simplest possible way.

In all that has gone before, nothing but plain weaving has been suggested; in other words, only two sets of heddles have been used and only two treadles.

To do pattern weaving, it will be necessary to use four sets of heddles and four treadles. In Fig. 20 may be seen the four sets of heddle sticks just be-

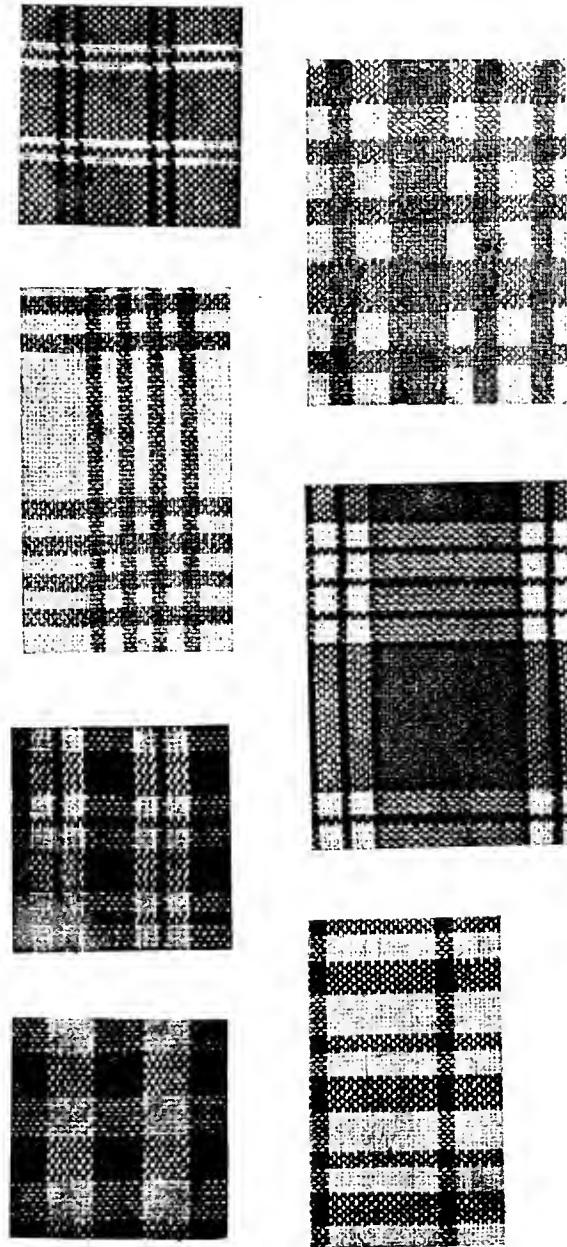


Fig. 60—Plaids

hind the beater. Heddles are placed on each pair of the sticks. They are hung for threading just as the two sets are hung in Fig. 32.

The warp is reeled and placed on the warp beam just the same for pattern weaving as for plain weaving. Let the pattern shown in Fig. 61 be the one for consideration. This pattern is known as the Monk's Belt. The name, no doubt, comes from its use in weaving the belts used by the early monks.

Let the material to be used be a four-ply white or gray carpet warp just the same as was used in the rug weaving. In the rug work only twelve threads to the inch were used. For this pattern twenty threads to the inch will be used.

If the article to be woven is to be about 22 inches wide and there are to be 20 threads to the inch, it will require 456 threads to be reeled, including 24 threads for the selvages. If four threads are reeled at a time, it will require 114 groups of four threads to make the required number. The length depends upon the weaver.

Having placed the heddles on the heddle sticks and the warp on the beam, the worker is ready to do the threading. Seated as shown in Fig. 32, with the pattern as shown in Fig. 61 at hand, the work of threading is begun.

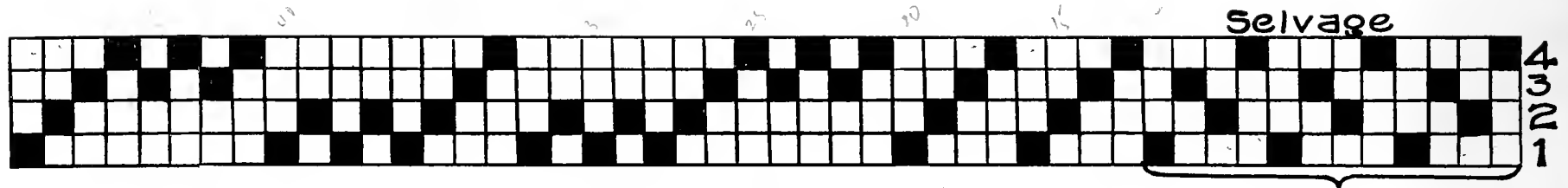


Fig. 61—Monk's Belt. Draft of Pattern

It must be remembered that the sets of heddles are numbered from the front to the back. That is, the heddle sticks just in front of the worker is number 1, the next number 2, the next number 3, and the farthest number 4. The row of squares in the pattern marked No. 1 indicates that all the threads in this row must be threaded in their order thru the heddles on heddle sticks No. 1. The squares in the pattern in row No. 2 indicate that these threads are threaded in their order thru the heddles on the second pair of heddle sticks. Three and four follow in the same manner.

Beginning to Thread

Beginning at the right of the pattern, the first thread of the selvage is indicated by a dark square in the fourth row. This means that the first thread passes through the eye of the first heddle on the back or fourth row of heddles. This heddle threaded, it is pushed along and the next thread is taken care of. The next thread is on the second row and is passed through the eye of the first heddle on the second pair

of heddle sticks. This heddle is now pushed along and the third thread is cared for. The third thread passes through the first heddle on the third pair of heddle sticks and is pushed along. The fourth thread passes through the eye of the first heddle on the first pair of heddle sticks and is pushed along. The fifth thread passes through the eye of the second heddle on the fourth row. This is continued until the part of the pattern marked selvage is completed. The selvage is threaded but once, at the beginning and at the end, unless otherwise indicated.

The threading of the real pattern begins after the selvage has been threaded. Upon investigation it will be found that 36 threads make one repeat of the pattern, Fig. 61. If there are 456 threads in all and 24 are used for the two selvages, 432 threads remain. If it requires 36 threads to thread the pattern once, 432 threads will repeat the pattern twelve times.

The first thread of the pattern appears on the fourth or back row of heddles; the second thread

example, if the finished work is to be 22 inches wide and the reed through which the threads are drawn is 28 inches long, it is of the greatest importance that the first thread is drawn through the dent three inches from the right end of the reed. After all the threads have been drawn thru the dents, three inches are left at the left end of the reed. The ends now are tied to the rod which leads to the cloth beam, the same as in Fig. 36.

Tying the Heddle Sticks

Fig. 20 shows the position of the heddle horses. Two heddle horses are tied together with a piece of No. 16 blocking cord. The cord is thrown over the roller or the pulley above, leaving one heddle horse at one side and one at the other, as shown in Fig. 20.

The upper heddle sticks are tied to the scroll-like ends of the heddle horses, one to each. To do this take four heddles the same as were used on the heddle sticks. These are looped all at one time over one end of the first heddle stick. This is done by placing one loop at the end of the heddle to one side of the heddle stick, as shown at A, Fig. 63. The other ends of the heddles are placed through this loop and are drawn tightly over the heddle stick. With the thumb and finger, make a loop in the other end of the heddles similar to the loop in Figs. 38 and 39. Slip this loop over the scroll-like end of the heddle

horse as shown at B, Fig. 63. Take four other heddles and loop one end over the second heddle stick far enough from the end so that it is directly under the other scroll-like end of the same heddle horse, as shown at C, Fig. 63.

With the finger and thumb, make a loop in the other end of the heddles and slip this loop over the other end of the heddle horse, as shown at D, Fig. 63. Heddle sticks 1 and 2 are now tied to the one heddle horse; see Fig. 63. Take four other heddles and loop them over the third heddle stick the same distance from the end as the first was looped at E, Fig. 64. Loop the other ends of the heddles over the scroll-like end of the second heddle horse, as shown at F, Fig. 64. The fourth heddle stick is tied in the same way and the same distance from the end as the second one, as shown at G and H, Fig. 64. This finishes the tying at one end. Tie heddle sticks at the other end to the heddle horses in the same way. Heddles are used to tie the heddle sticks to the heddle horses because they are all exactly the same length. This is of great importance.

Tying Heddle Sticks to Treadles

To keep the heddle sticks even and all together, tie them together at each upper end. From the center of each lower heddle stick, tie a loop of No. 16 blocking cord as shown at A, Fig. 37.

From each treadle allow two ends of No. 16 blocking cord to extend upward. Beginning at the right, tie the first treadle to the first lower heddle stick; the second treadle to the second heddle stick. In the same way tie 3 and 4. This numbers the treadles from right to left 1, 2, 3, 4. The loom is now ready for work.

Weaving the Pattern

Before beginning to weave the pattern, experiment by pressing down certain treadles. Press down treadles 1 and 2 at the same time. Press down 3 and 4. Press down 1 and 3 by placing one foot on 1 and the other on 3. Press down 2 and 4. It will be found that 1 and 2, when pressed down, make one part of the pattern, as shown at A, Fig. 65.

By pressing down treadles 3 and 4, the part of the pattern shown at B, Fig. 65, is made.

These two changes are all that are found in Fig. 65. C, Fig. 65, is the same as A, only there are fewer threads used in weaving C. D, Fig. 65, is the same as B; and E, Fig. 65, is the same as A.

It was found that when treadles 1 and 3 were pressed down exactly one-half of the threads were drawn down. When 2 and 4 were pressed down the other half of the threads were drawn down.

Any amount of plain weaving may be done by pressing down alternately 1 and 3 at the same time, and 2 and 4 at the same time. This being true,

it is possible to place pattern borders with as much plain weaving in between as is desired.

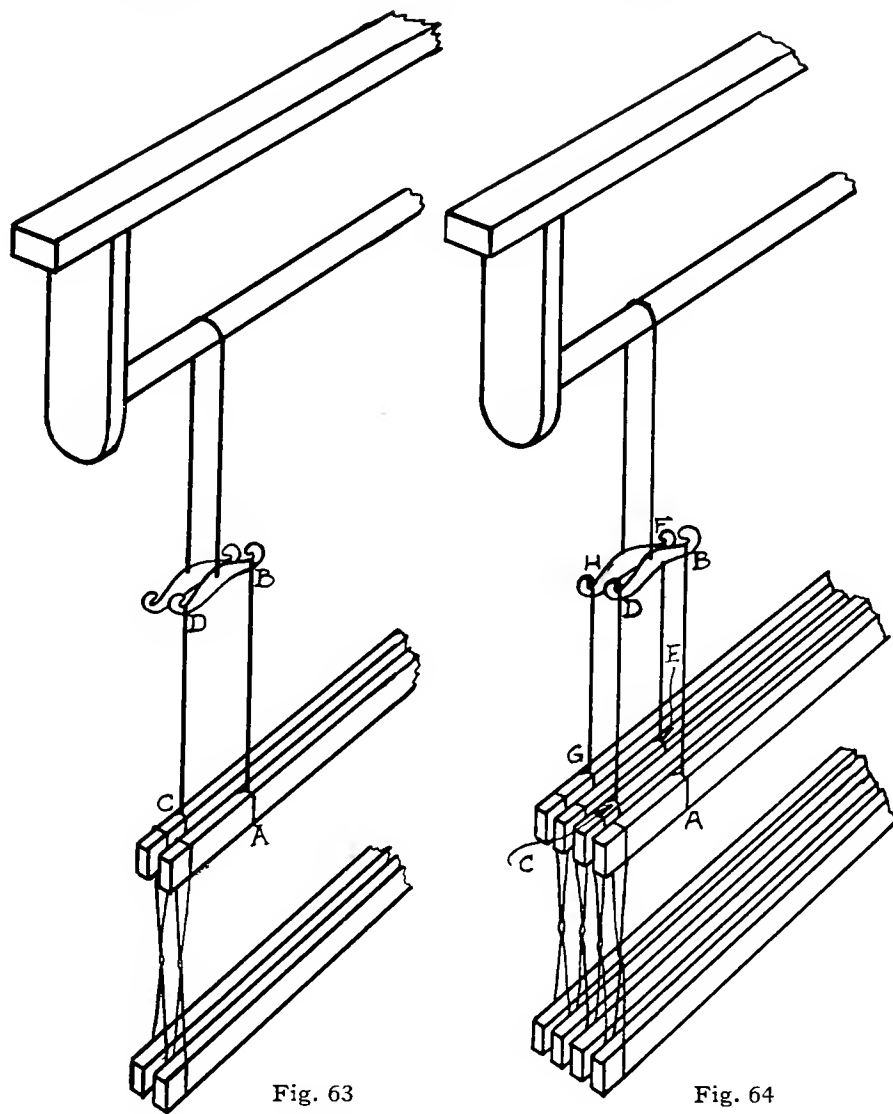


Fig. 63

Fig. 64

Tying the Heddle Sticks

When doing pattern weaving the thread used in the pattern should be at least as heavy as the warp.

For every pattern thread that is placed in the weaving there must be what is called a binding thread or binder. The binding threads are always put in while the feet press down treadles 1 and 3, and 2 and 4. It will be remembered that it is these two sets of treadles that make the plain or tabby weave.

Let us suppose that everything is ready to begin the actual weaving. Treadles 1 and 3 are pressed down at the same time and the shuttle is passed from the right through the shed to the left.

Treadles 2 and 4 are next pressed down and the shuttle is passed through the shed from the left to the right. In this way as much plain weaving may be done as is desired.

If a table runner is to be made, about five inches

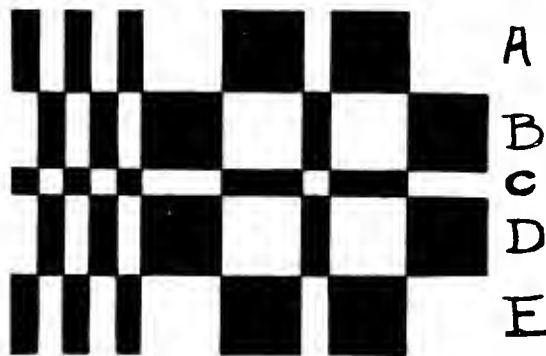


Fig. 65—Pattern Woven

of plain weaving in the beginning are sufficient before introducing the pattern.

To Make the Border as Shown in Fig. 65

When weaving a pattern there must always be a binder woven in every time a pattern thread is woven. It is this binder that holds the pattern thread in place. It is always well to have the binder of finer thread than that used in the plain weave, or than that used in the pattern, as the pattern threads may be more closely beaten together.

The shuttle containing the thread to be used for the binder is now at the right.

Treadles 1 and 2 are pressed down at the same time and a pattern thread passed through the shed. When this is beaten in place, treadles 1 and 3 are pressed down and a binder thread is passed through the shed. Treadles 1 and 2 are again pressed down and a pattern thread passed through the shed. Treadles 2 and 4 are now pressed down and a binder passes through the shed. Press 1 and 2 again for the pattern thread and 1 and 3 for the binder. Press 1 and 2 again, and 2 and 4 for the binder.

The weaver has, no doubt, discovered by this time that the pattern thread may enter the shed from either the right or left while care must be taken to enter the binder from the side it should be entered in order to make the plain weave. With the amateur it might be well to give the following direction con-

cerning the weaving in of the binder: When the first and third treadles are pressed down the binder must always enter from the right, and when the second and fourth treadles are pressed down the binder enters from the left. The beginner when returning to the work often finds it difficult to know which treadles to press down for the first binder thread. This may be decided by the position of the shuttle. If the thread from the shuttle is to the right then treadles 1 and 3 are pressed down for the binder. If the thread is at the left then 2 and 4 are pressed down. In other words, when the right foot presses down one of the outside treadles the shuttle must enter the shed from the right side and when the left foot presses down an outside treadle the shuttle enters the shed from the left side. This will aid the beginner in keeping track of the binding thread.

Second Change in Pattern

The second change in the pattern is shown at B, Fig. 65. To weave in the pattern threads for this change, treadles 3 and 4 are pressed down each time. Three and four are pressed down and the shuttle containing the pattern thread is thrown through the shed.

The shuttle containing the binder is at the right, therefore treadles 1 and 3 are pressed down. The shuttle at the right means that the right foot

pressed down the right treadle. If it had been at the left, then 2 and 4 would have been pressed down, the left foot pressing down the left treadle which is the outside treadle to the left.

C, Fig. 65, is the same as A; and D is the same as B. E is the same as A.

Checked Paper

After the pupils have worked out the design shown in Fig. 65, pass to them checked paper and have them work out as many different combinations taken from Fig. 65 as possible.

When this is done the different combinations may be woven on the loom.

Fig. 66 and Fig. 67 show a few such combinations.

Adaptations

There is very little value in asking pupils to design in textiles if they know nothing about the real working of a loom. At first thought one is very likely to look upon loom weaving as a very mechanical line of work because of the fact that the loom is threaded for a certain pattern. This work may be made so if the teachers cannot see beyond the one little pattern for which the loom is threaded. If, however, the instructor will use the checked paper freely and have the pupils make as many different combinations of the changes shown in Fig. 65 as possible, a great deal of good may be derived from

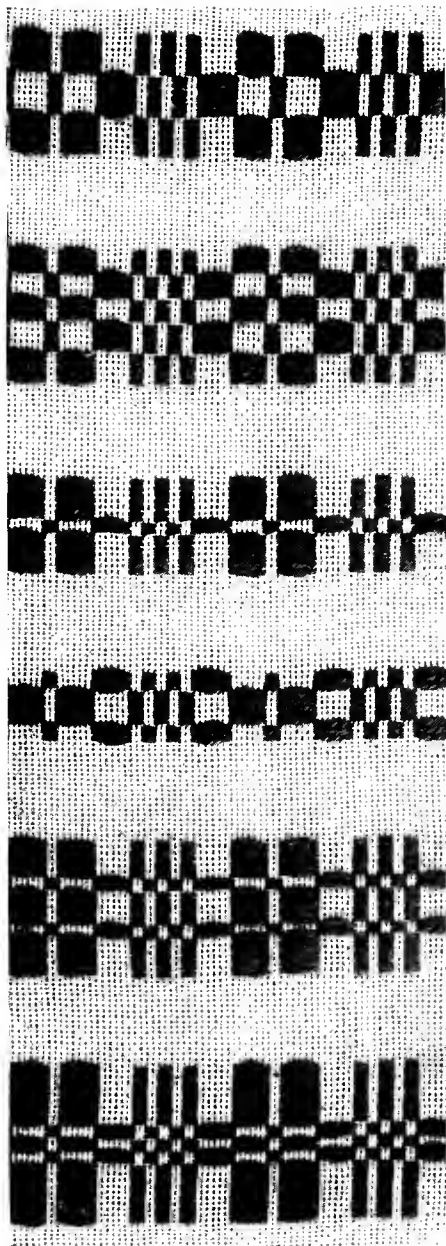


Fig. 66—Borders

the standpoint of design and color. Attention has already been called to the combinations shown in Figs. 66 and 67. These interesting borders may be woven into table-runner borders, bags of various kinds, pillow tops, curtains, etc.

In Fig. 68 is shown a bag for fancy work. The material for the plain part is of Ecu Jap Six No. 20. Twenty threads to the inch were used, two threads passing through each dent. The border is of a No. 5 mercerized cotton.

Fig. 69 shows a knitting bag in which the Monk's Belt threading is used. This bag was woven on the same loom as was the fancy work bag. The change in design is due to a change in colors and the order of treading for the stripes. The Jap silk is the same.

When one begins really to work, the possibilities begin to dawn.

Fig. 70 shows a pair of curtains woven of Egyptian twine. A number 20 reed is used, one thread passing through each dent. A No. 3 mercerized cotton is used for the border, which is another adaptation of the Monk's Belt. The binder is Egyptian twine.

Numerous all-over designs may be produced by using the threading draft shown in Fig. 61.

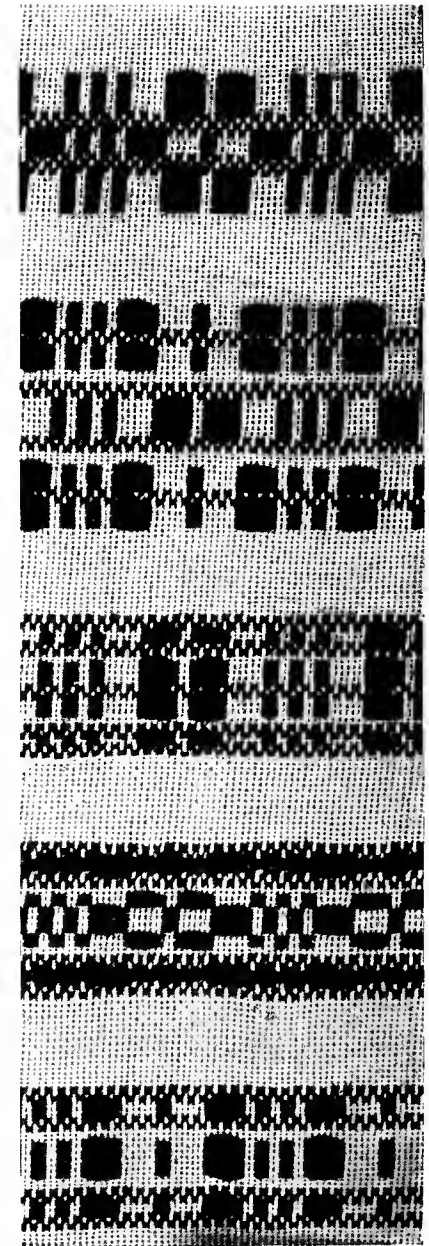


Fig. 67—Borders

esting of all the simple threadings and may be worked out by beginners in a great variety of ways and colors.

When threading any pattern always begin at the right and work toward the left.

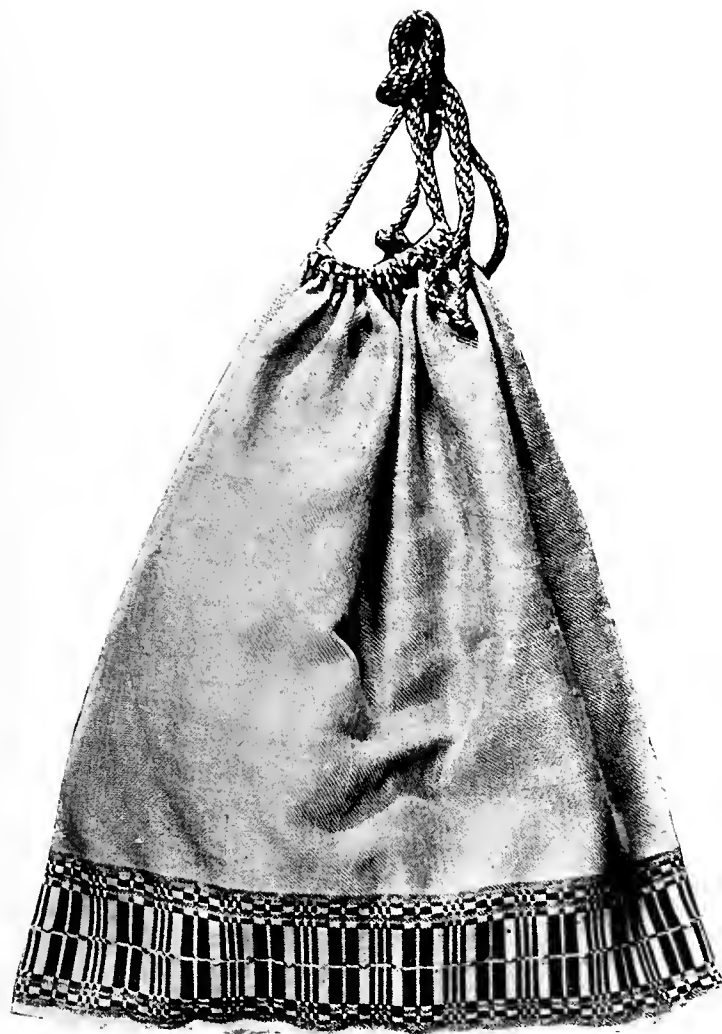


Fig. 68—Fancy Work Bag

The Rose Path

Figure 71 shows the threading for the pattern called the Rose Path. It is one of the most inter-



Fig. 69—Knitting Bag

Threading for the Rose Path

Thread first the selvage. There are but eight threads in a single repeat of the pattern. The material to be woven is 20 inches wide plus the width of the selvages.

If there are to be 20 threads to the inch, it will require 400 threads plus sixteen threads for the selvages, making in all 416 threads.

If four threads are reeled at a time, it will be necessary to reel 104 groups.

Since 400 threads are used for the pattern and there are eight threads to each repeat, the pattern may be repeated 50 times.

The selvage is threaded the same for the Rose Path as was threaded for the Monk's Belt.

The first thread of the pattern is drawn through the eye of the first heddle on the back row.

The second thread goes through the eye of the first heddle on the third heddle sticks.

The third thread passes through the eye of the first heddle on the second heddle sticks.

The fourth thread passes through the eye of the first heddle on the first heddle sticks. From here the threading runs back to the fourth heddle sticks.

The eighth thread of the pattern passes through the eye of the second heddle on the first heddle sticks. This finishes one repeat. All the other repeats are simply a repetition of the first.



Fig. 70—A Pair of Woven Curtains

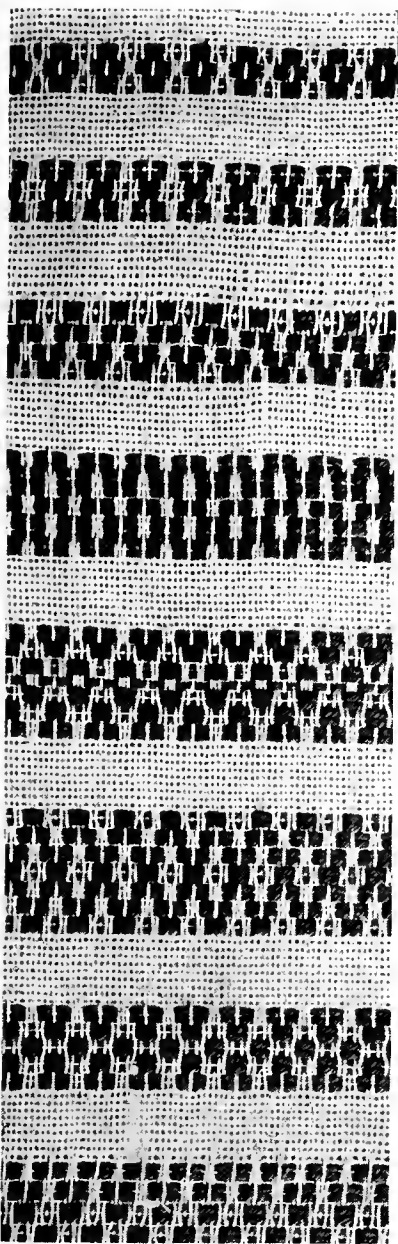


Fig. 72—Borders

The left selvage is the same as the right.

If a number 20 reed is used, two threads of the selvage are drawn through each of the first six dents and then one thread through each dent until the left selvage is reached, when two are again drawn through each of four dents.

If a number 10 reed is used four threads of the selvage are drawn through a dent at a time and then two threads through each dent until the left selvage is reached.

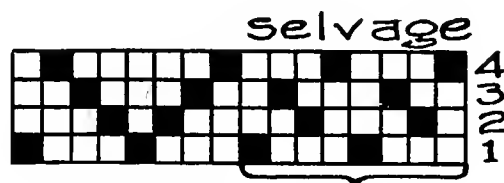


Fig. 71—Rose Path. Draft of Pattern

The upper heddle sticks are tied to the needle horses the same as for the Monk's Belt.

The lower heddle sticks are also tied to the treadles the same as in the Monk's Belt.

Weaving the Pattern

It must be remembered that the treadles are always numbered from right to left. By pressing down treadles 1 and 3, one-half the threads are drawn down. Treadles 2 and 4 are drawn down the other half.

With the shuttles containing both the pattern thread and the binder at the right, press down

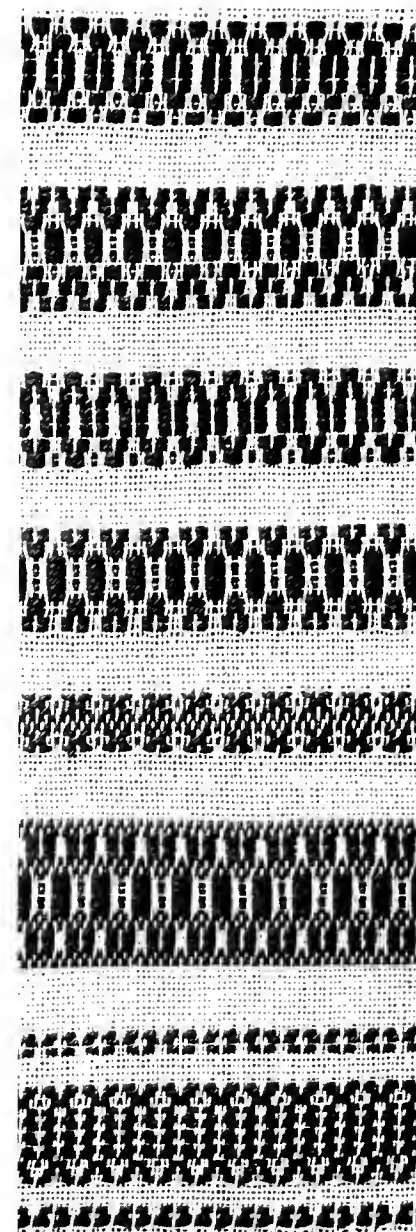


Fig. 73—Borders

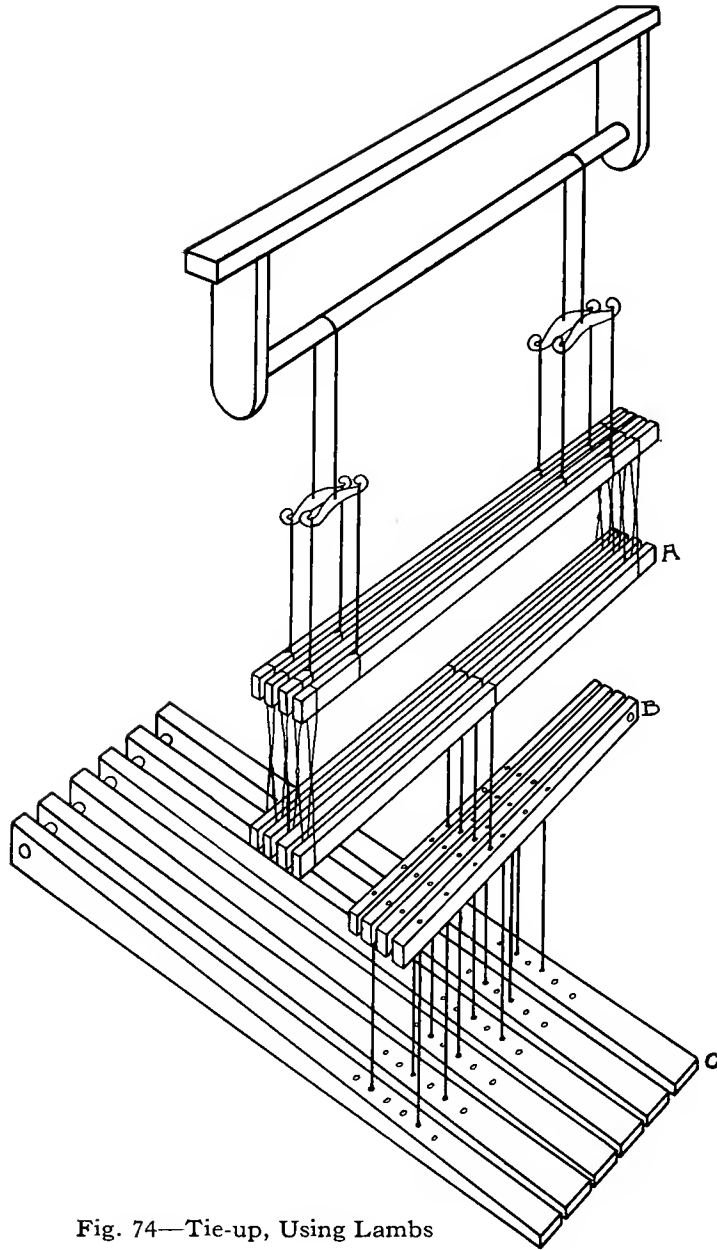


Fig. 74—Tie-up, Using Lambs

treadles 1 and 2 and pass the pattern thread through the shed.

Press down treadles 1 and 3 and through the shed pass the binder. Press 1 and 2 down again and through the shed pass the pattern thread.

Press down 2 and 4 and pass the binder through the shed.

To press down the treadles in the following order:

1 and 2	2 and 3	1 and 4
1 and 3 Binder	2 and 4 Binder	1 and 3 Binder
1 and 2	3 and 4	1 and 4
2 and 4 Binder	1 and 3 Binder	2 and 4 Binder
2 and 3	3 and 4	
1 and 3 Binder	2 and 4 Binder	

When the above has been completed all the changes possible in this threading are shown.

On ruled paper have the pupils make as many combinations of the above changes as possible.

Figures 72 and 73 show a few of the combinations woven into borders.

The Rose Path is full of interesting combinations which may be used in borders for curtains, bags, table runners and pillow tops.

Finer Threads Used for Warp

It is not necessary to confine the warp used to the ordinary four-ply carpet warp. It must be remembered, however, that the finer the warp the more threads there must be to the inch.

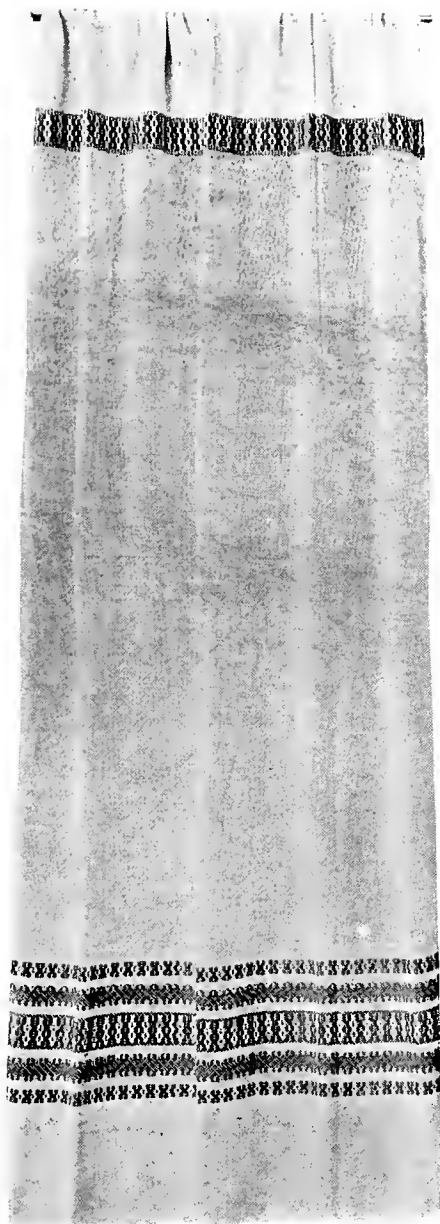


Fig. 75—Curtain Border. Adaptation from Rose Path

For extra fine work the mercerized cotton may be used. This is obtainable in various sizes. Numbers 3 and 5 are most commonly used. Jap silk No. 20 makes a very good warp for finer articles. Glo silk is also good. To the one interested there is an unlimited variety to be had.

The Lambs

In the pattern weaving up to this time the loom has been tied up in such a way that it has been necessary to use both feet in pressing down the treadles to bring about the desired changes in the pattern.

Fig. 74 shows the drawing of such parts of the loom as are concerned in pattern making. At A, Fig. 74, are shown the heddle sticks without the heddles.

At B are shown the lambs. The lambs are new and no reference up to this time has been made to them. C, Fig. 74, illustrates six treadles instead of four as shown and described in previous drawings.

The working drawing of the loom will show the lambs held in place at one end by brackets screwed to the inner right side of the loom at B, Figs. 74 and 20. By the use of the lambs, the loom may be so tied up that one foot will press down the desired number of heddle sticks at one time.

The tying of the upper heddle sticks to the

heddle horses is the same as shown at A and as previously described.

On examination of B it will be found that instead of the treadles being tied directly to the lower heddle sticks, it is the lambs which are tied, one to each lower heddle stick.

This tying of the lambs is done exactly the same as if the treadle were being tied.

B, Fig. 74, shows holes bored in the lambs.

When the lambs are tied to the lower heddle sticks, attention will be given to the treadles. There are six treadles in all.

The two center treadles are used in drawing down the heddles that will do the plain weaving. The other four, two at each side of the center, are used to make the pattern. These are numbered from right to left, 1, 2. Skip the two center ones and number the last two, 3 and 4.

If the first change in the pattern indicates that heddle sticks 1 and 4 are to be drawn down, then

the lambs 1 and 4 are tied to the first treadle, as shown in Fig. 68. When treadle No. 1 is pressed down, it draws down lambs 1 and 4. Since lambs 1 and 4 are tied to the lower heddle sticks 1 and 4, the pressure must draw down the heddles.

If the next change in the pattern indicates that heddles 2 and 3 are to be drawn down, then lambs 2 and 3 are tied to treadle No. 2 as above described.

This is continued until all treadles have been tied to draw down the right heddles. The heddles doing the plain weaving are tied to the two center treadles. The knot used in the tying has been fully described in Figs. 37, 38, 39 and 40.

Fig. 75 shows an adaptation of the Rose Path to a border which may be used in curtains. A number 9 reed is used; one thread to each dent. The woof and warp are of the same material. Care is taken not to beat the woof too hard. This material resembles a coarse scrim. A number 3 mercerized cotton is used in the border and a 2-ply thread is used for the binder.

CHAPTER III

Colonial Patterns

Many of the patterns used by amateur weavers of today are simply the old Colonial patterns which have been handed down from one generation to another.

It is difficult to know just where they first originated. The names often suggest the country from which the original pattern might have come. Such names as the Olive Leaf and Bonaparte's March may have come from France; the Queen's Delight and the Governor's Garden may have come from England; while the Whig Rose may have originated in our own country as late as the time when the Whig Party sprung into existence. One of the interesting features of this work, to the amateur weaver of today, is not to accept the patterns just as they have been handed down, but to make such changes as will enable the finished products to find an appropriate place in the house furnishings of today.

The patterns which follow are given as they were originally woven, together with such changes as make them desirable at this time.

Reading a Draft

"Draft" is the term usually applied to a threading as shown in Figs. 76 and 77. This, when properly followed, produces the pattern as shown in Figs. 78 and 79. Fig. 78 shows the upper or right side and 79 shows the under side of the finished weaving. "The Big Diamond" is the particular name of this pattern.

The following is a detailed description of the pattern:

First: In threading a pattern always begin to read at the right. When the first part is finished begin at the right of the second, etc.

Second: The pattern begins with the first thread after the right selvage and ends with the last thread just before the left selvage.

Third: Find the number of threads to make one repeat. All threads within a brace are to be repeated the number of times indicated. For example, 4X means to repeat the threading four times. The actual number of threads in this pattern is 168. If a number 20 reed is used this pat-

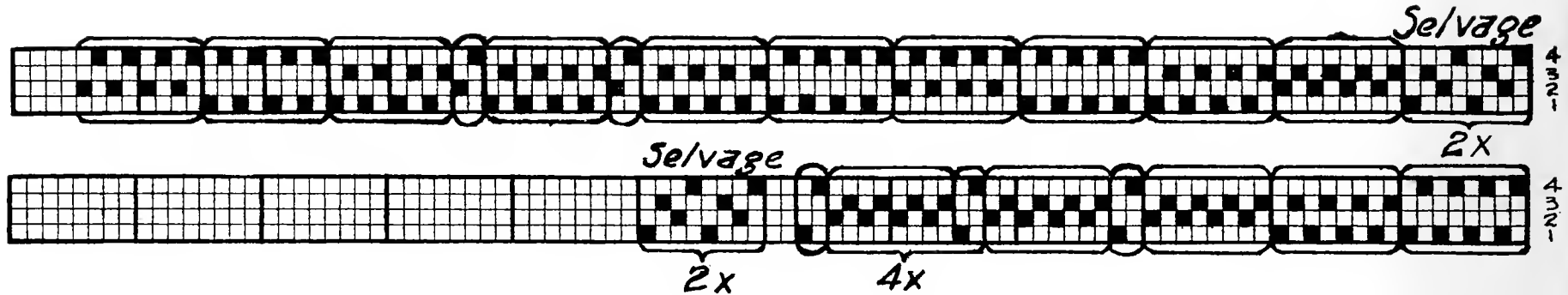


Fig. 76—The Big Diamond. Draft of Pattern with Each Group Marked

tern may be threaded two full times and up to the place marked by the arrow the third time. Directly following this the selvage is threaded.

The number of threads to produce the piece of cloth is as follows:

Two times 168 threads, plus 108 threads (up to arrow), plus 32 threads for selvage, making in all 476 threads. The use of a four-ply carpet warp and a No. 10 reed and two threads to the dent makes a table runner about 24 inches wide while in the loom.

After the warp has been reeled and placed on the beam, the threading may begin.

Fourth: Threading—The selvage is threaded as before described. The 2X indicates that the threads within the brace are to be threaded twice.

Beginning with the real pattern the first thread passes through the eye of a heddle on the third heddle sticks. The second thread passes through the eye of a heddle on the second heddle sticks.

The draft shows that this combination is repeated four times; this is indicated by the brackets

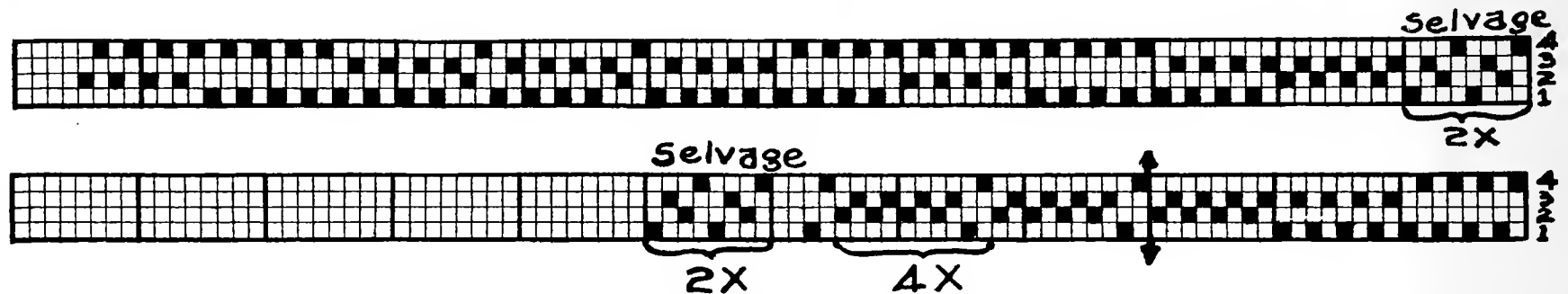


Fig. 77—The Big Diamond. Draft of Pattern

drawn around this group. The next group is made up of the combination of 3 and 1, indicated by brackets.

The next threads run in the combination of 4 and 1, and the next 4 and 2, as indicated by brackets. The threading is continued until the left selvage is reached, the brackets indicating the grouping. From this place the threading begins at the beginning of the pattern and is repeated a second time straight through to the left selvage; care must be taken to thread the threads within the brace the number of times indicated. The second time completed, the pattern is threaded a third time up to the threads marked by the arrow. The left selvage threaded now completes the threading of the entire warp.

The draft is usually written as shown in Fig. 77.

Fifth: The threading completed, the threads are drawn through the reed, two to each dent. Care must be taken to draw the threads through the dents so the threading is in the middle of the reed. This has been explained previously.

The Tie-Up

The upper heddle sticks are tied to the heddle horses as before described.

The lower heddle sticks are tied, one to each of the lambs instead of directly to the treadles.

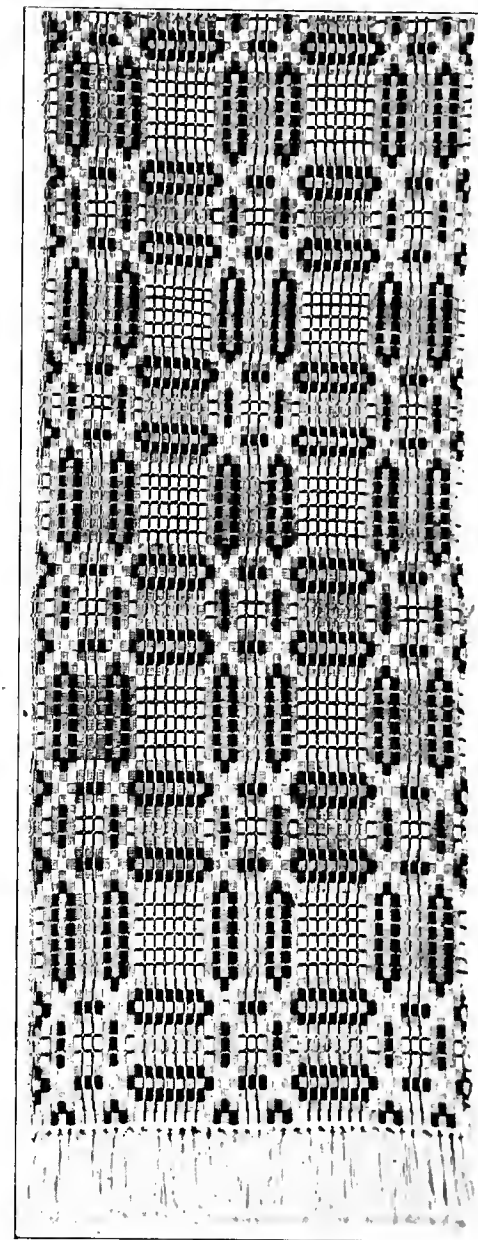


Fig. 79—Under Side of Finished Weaving

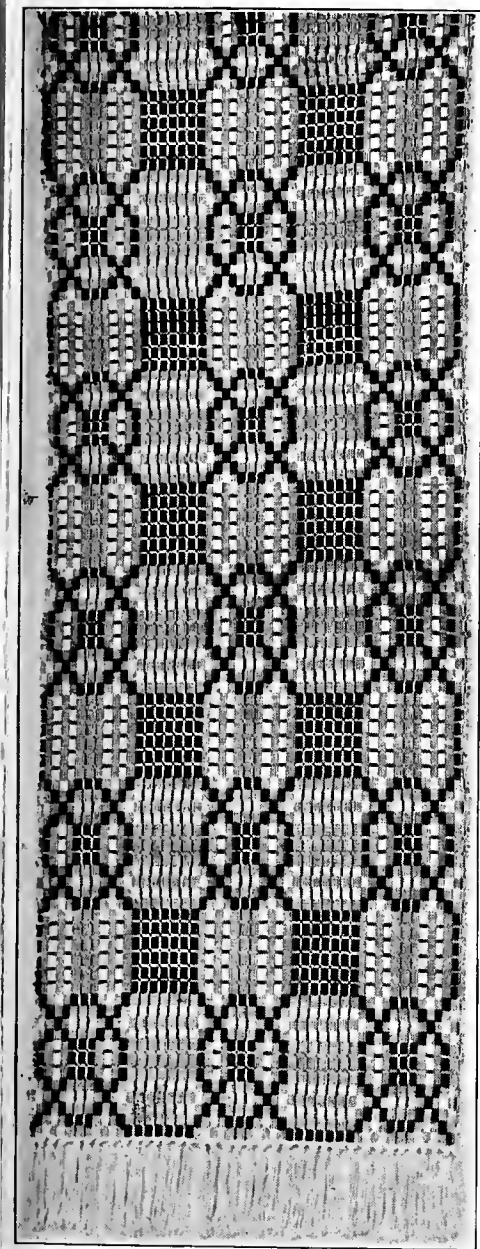


Fig. 78—Right Side of Finished Weaving

The treadles are tied to the lambs in the order indicated by the draft.

The first combination in the threading is 2 and 3, therefore lambs 2 and 3 are tied to the first treadle. The next combination is 1 and 3, then 1 and 3 are tied to the second treadle.

The third change in the pattern is 1 and 4. It is tied to the fifth treadle which is next to the last, skipping the two center ones.

The fourth combination is 4 and 2 which is tied to the last treadle.

The plain weaving for this pattern is done by pressing down heddle sticks 1 and 2 at one time, and 3 and 4 the next. This means that lambs 1 and 2 are tied to the right middle treadle, and 3 and 4 are tied to the left middle treadle.

Weaving the Pattern

Before beginning the real pattern about one-half inch of plain weaving is done. This is done by pressing down first one and then the other of the two middle treadles.

With the shuttle at the right, press down the first treadle which draws down heddle sticks 2 and 3. Through the shed pass the first pattern thread.

For the binder press down the middle treadle to the right. For the second pattern thread press down the first treadle again. The thread for the

plain weaving is at the left, so the left treadle is pressed down and the binder is sent from the left to the right.

For the third pattern thread press down the first treadle again. The binder is now at the right, so the right middle treadle is pressed down. This is continued until the first treadle is pressed down as many times as there are threads indicated in the first combination. In this case there are eight, and the binder is used after each pattern thread. If eight times makes too large a color spot, press down the first treadle only six or even four times. The weaver must be the judge.

The second change in the pattern is 1 and 3 in the threading, therefore the second treadle which draws down 1 and 3 is pressed down 4, 6 or 8 times, just as the weaver desires.

The third change is 1 and 4, so the fourth or next to the last treadle is pressed down 4, 6 or 8 times. The fourth change is 2 and 4, so the last treadle is pressed down 4, 6 or 8 times.

It will be observed that the threads all come in combinations. Sometimes the combination consists of only two threads. When this is true then only two pattern threads are run across.

The draft shown at Fig. 77 tells all that must be known about a pattern to produce the finished piece of cloth.

It must be remembered that the pattern may be woven by using only four treadles, one tied to each heddle stick as described in the Monk's Belt and the Rose Path.

In case each heddle stick is tied to a treadle, the pattern is produced by pressing down treadles 2 and 3 as many times as desired. Then 1 and 3 as many times as desired, 1 and 4 and then 2 and 4.

The plain weaving is done by pressing down treadles 1 and 2 at one time, and treadles 3 and 4 at another.

The patterns which follow will be described in as brief a way as possible, because all tying and treadling are read in the draft as above described.

Fig. 80 shows the original draft for the Double Snowball, and Fig. 81 shows the woven pattern

when the draft shown in Fig. 80 is followed. It requires 396 ends for one repeat of the pattern.

Where to Begin

Owing to the width of looms it is necessary to weave counterpanes and couch covers in two strips, to be sewed together. In all drafts care is taken to begin the threading so two edges may be sewed together to make one complete pattern, just the same as figured carpets are woven and sewed.

The tie-up: Each lower heddle stick is tied to a lamb.

The lambs are tied as follows:

1 and 4 to the first treadle.

1 and 3 to the second treadle.

2 and 3 to the third treadle.

2 and 4 to the fourth treadle.

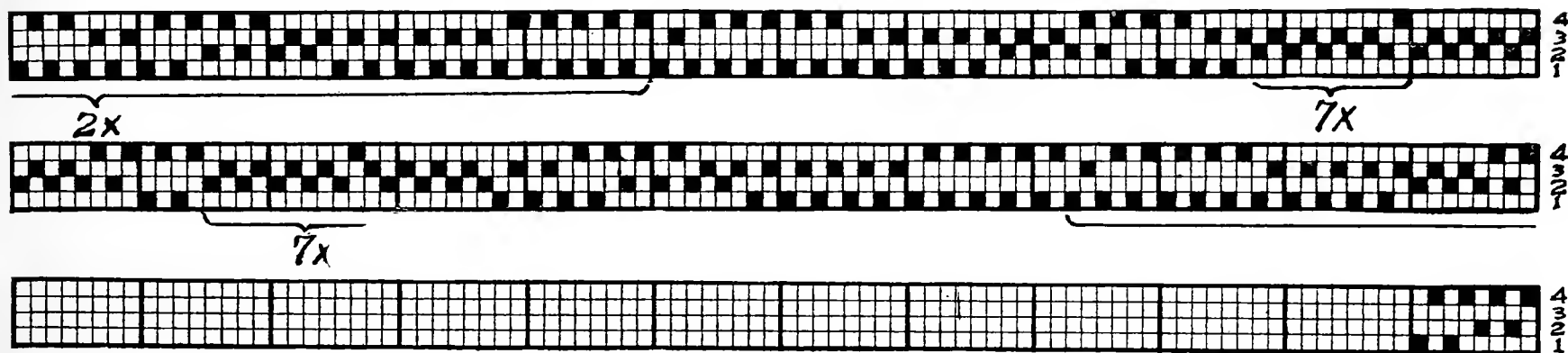


Fig. 80—The Double Snowball. Draft of Pattern

The plain weave is done by tying lambs:
 1 and 2 to the right middle treadle,
 3 and 4 to the left middle treadle.

Figure 83 shows an adaptation of the Double Snowball. It is not difficult to find the part of the pattern used in the original pattern. This particular part when used alone as in Fig. 82 is often called the Dogwood Blossom.

Figure 82 shows the draft for the adaptation and is read as follows:

First: 704 threads required for the entire pattern.

Second: Each lower heddle stick is tied to a lamb.

Third: The lambs are tied as follows:

- 1 and 4 to the first treadle.
- 1 and 3 to the second treadle.
- 2 and 3 to the third treadle.
- 2 and 4 to the fourth treadle.

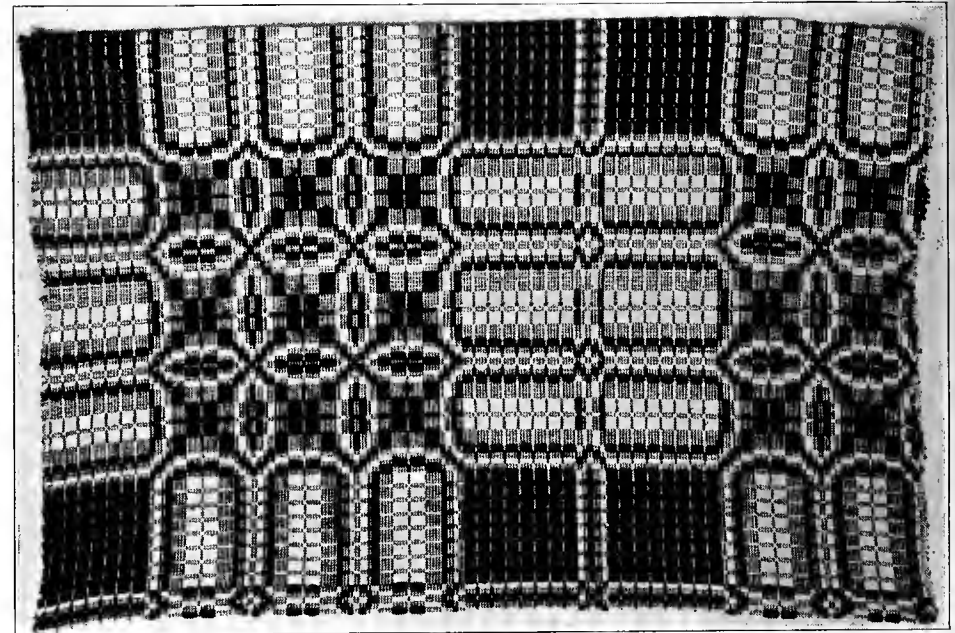


Fig. 81—Finished Weaving Using Double Snowball Pattern

The plain weave is done by tying lambs:
 1 and 2 to the right middle treadle.
 3 and 4 to the left middle treadle.

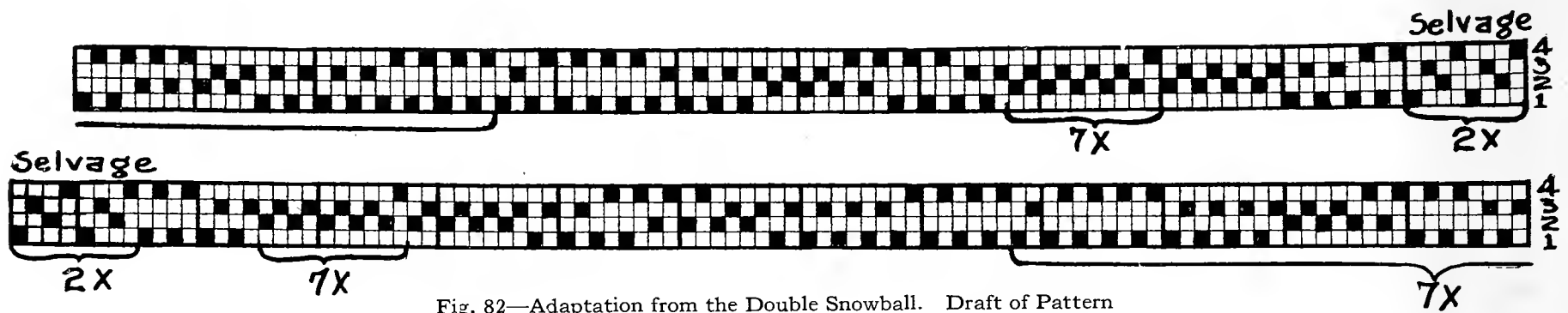


Fig. 82—Adaptation from the Double Snowball. Draft of Pattern

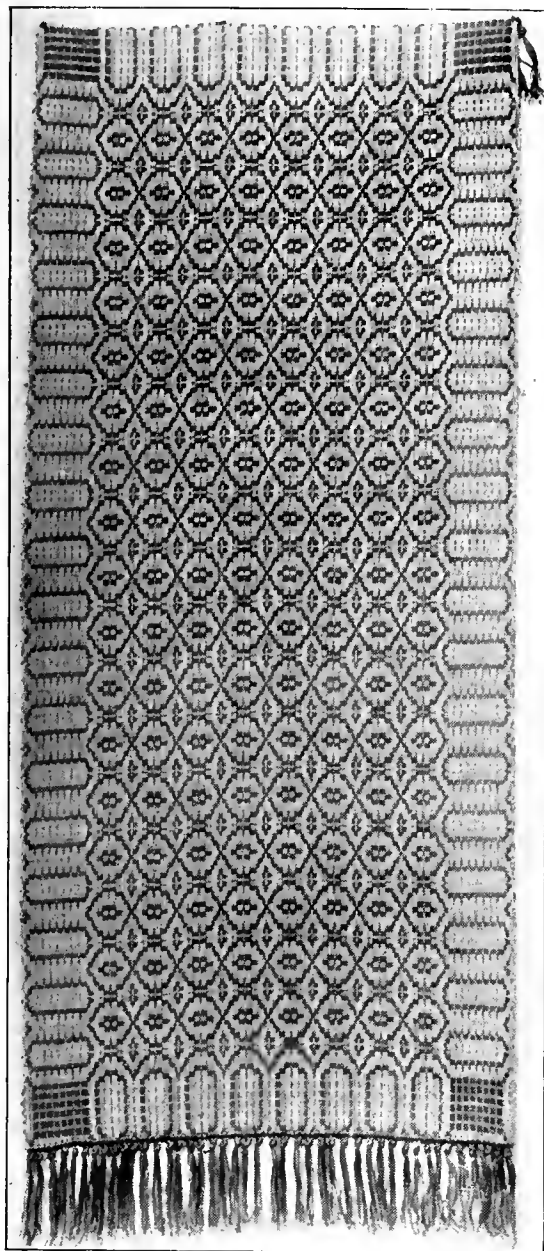


Fig. 83—Right Side of Table Runner

The material is a two-ply unbleached cotton warp.

Use a No. 15 reed, placing two threads to a dent.

The material used in the pattern may be a colored four-ply carpet warp or a No. 3 mercerized cotton. The two-ply carpet warp may be used for the binder or a fine mercerized thread may be used.

When weaving the pattern, the part within the brace is woven as many times as is indicated by the figure. For example, the brace marked 7X means all within the brace is woven seven times before proceeding with the remainder of the pattern.

Figure 81 shows the original pattern, while Figs. 83 and 84 show a table runner taken from Fig. 81.

This pattern is often used for pillow tops. In such a case a square is woven.

Fig. 85 shows a draft taken from what is known as Block Work, the original of which is shown in Fig. 86. This design, as well as many of the old Colonial patterns, is full of suggestions for pillow tops, table runners and even counterpanes.

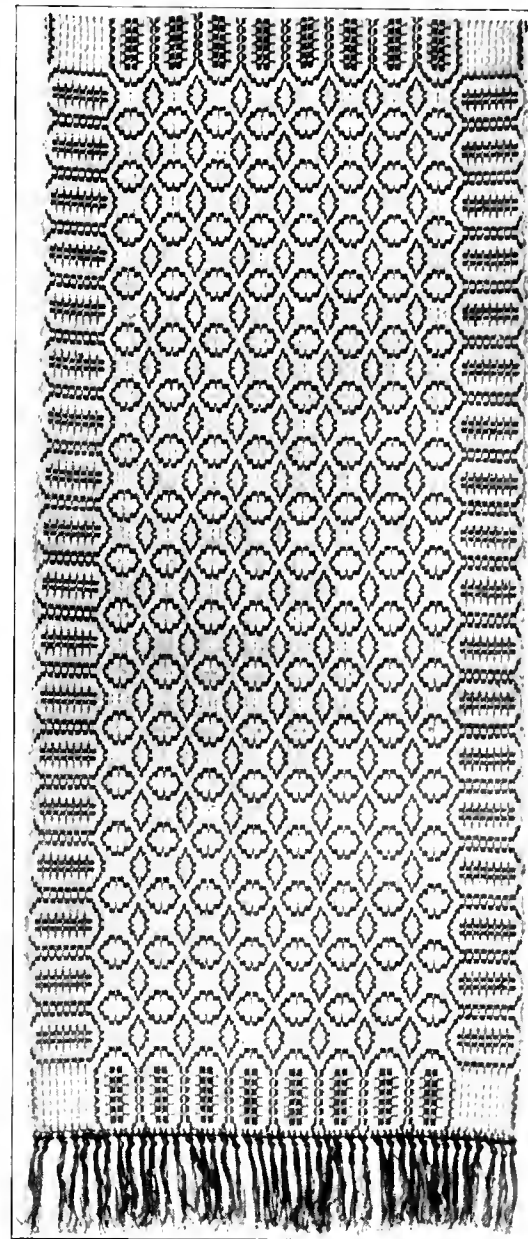


Fig. 84—Under Side of Table Runner

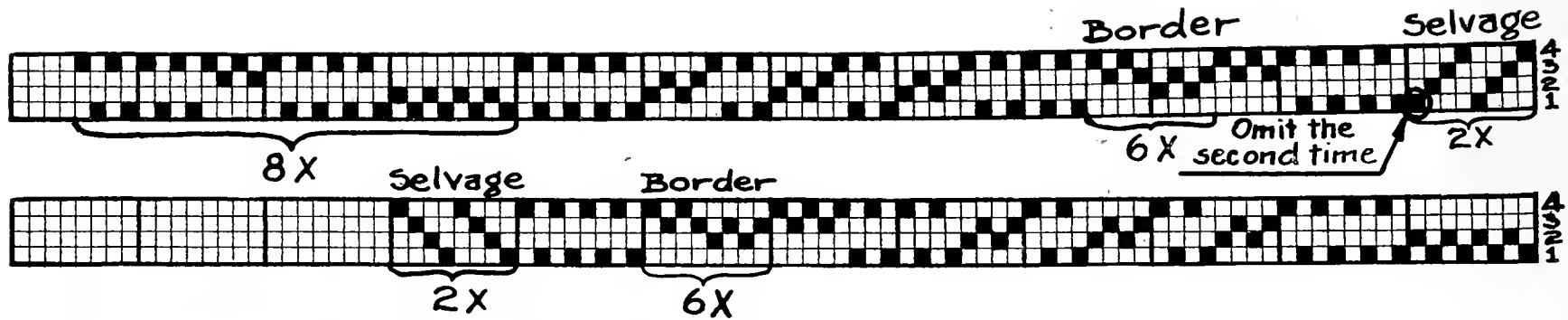


Fig. 85—The Block Work. Draft of Pattern

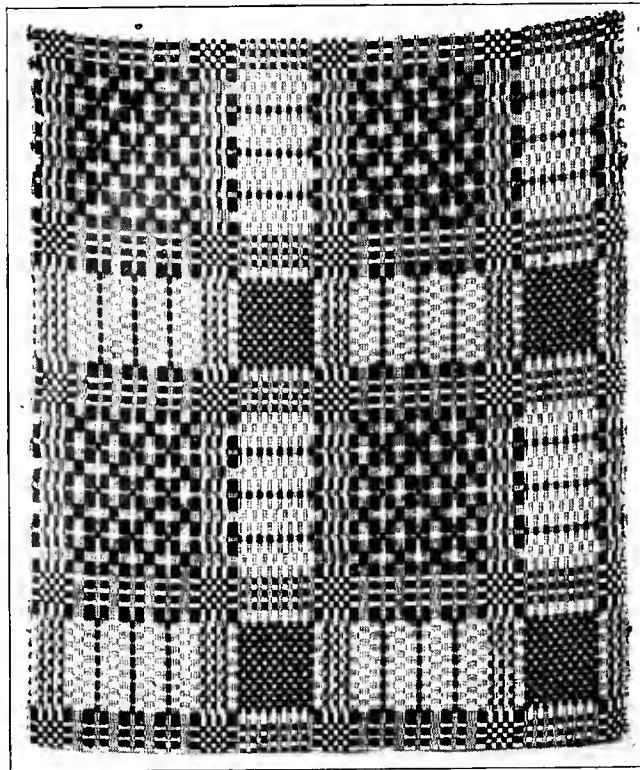


Fig. 86—Finished Weaving of Block Work

Figure 87 shows a pillow top taken from Fig. 86. There will be no difficulty in locating Fig. 87 in Fig. 86.

Figure 88 shows a table runner taken from Fig. 86.

Figure 88 was woven on the same loom, with the same threading as the pillow top shown in Fig. 87.

Reading of the Draft, Fig. 76

No. 10 reed, two threads to a dent.

456 threads four-ply carpet warp required.

Each lower heddle stick is tied to a lamb.

The lambs are tied as follows:

1 and 4 to the first treadle.

3 and 4 to the second treadle.

2 and 3 to the third treadle.

1 and 2 to the fourth treadle.

For plain weave tie:

1 and 3 to the right middle treadle.

2 and 4 to the left middle treadle.

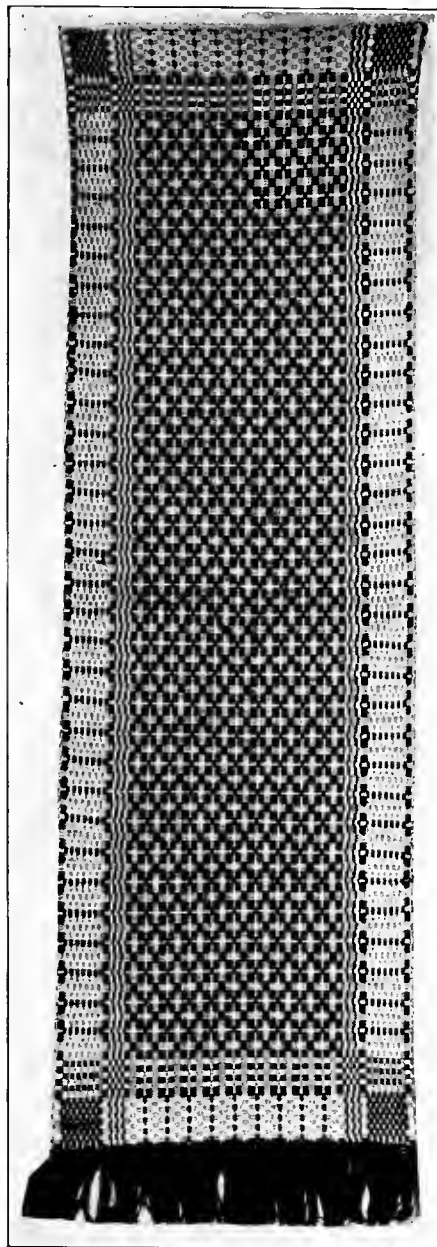


Fig. 88—Table Runner Woven from Block Work

Observe that the last thread of the right selvage is omitted in the second threading. This is done to avoid two threads coming together on the same heddle stick.

Chariot Wheel

Figure 89 shows a draft taken from what is known as the Chariot Wheel pattern.

Figure 90 shows a pillow top woven on a loom threaded with Fig. 89.

Figure 91 shows the under side of Fig. 90.

Very often the under side of the weaving is more attractive than the upper which is the right side. The design of the under side is usually more broken, thus making it many times more desirable from an art standpoint.

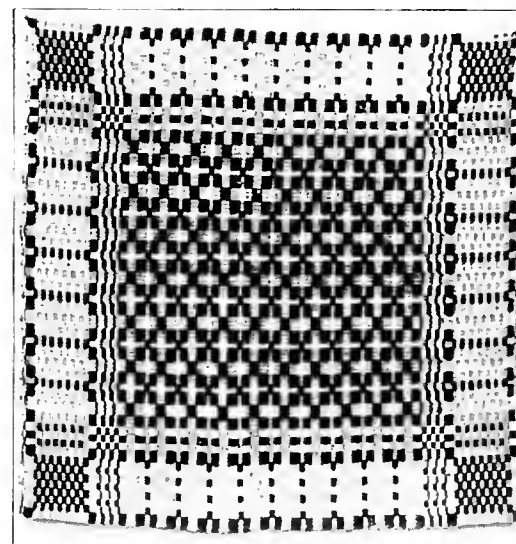


Fig. 87—Finished Pillow Top

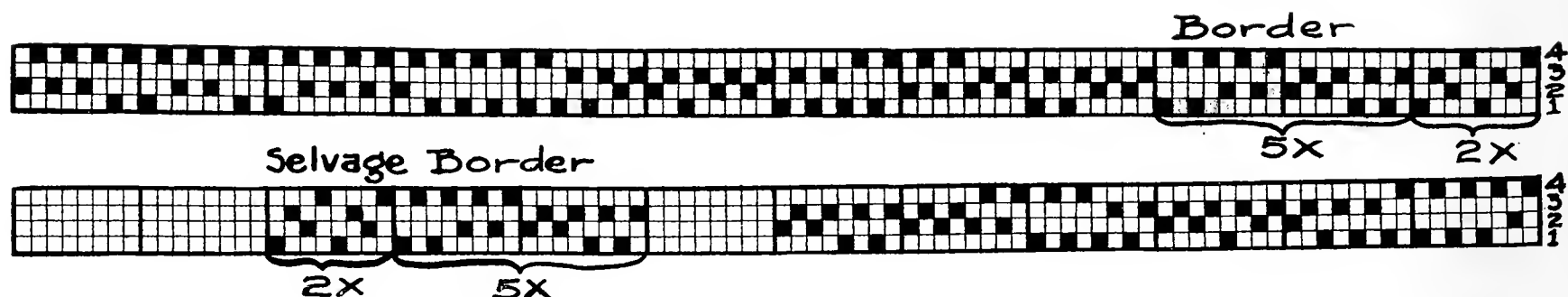


Fig. 89—The Chariot Wheel. Draft of Pattern

When making a pillow, let one side of the pillow show the right side and the other the under side of the weaving.

Figure 92 shows a counterpane, using the draft shown in Fig. 89.



Fig. 90—Pillow Top Woven from Chariot Wheel Pattern

Reading the Draft, Fig. 89

Material: A two-ply unbleached carpet warp. Number 15 reed, placing two threads to a dent.

Woof: Any color of wool, four-ply carpet warp or No. 3 mercerized cotton; 672 threads required to complete the threading.

The lower heddle sticks are tied one to each lamb.

The lambs are tied as follows:

- 1 and 3 to the first treadle.
- 2 and 3 to the second treadle.
- 2 and 4 to the third treadle.
- 1 and 4 to the fourth treadle.

For the plain weave:

- 1 and 2 tie to the right middle treadle.
- 3 and 4 tie to the left middle treadle.

When threading the draft as shown in Fig. 80, thread the right selvage first and then the border,



Fig. 91—Under Side of Pillow

repeating the threads within the brace the number of times indicated. The real pattern begins just after the right border. This part of the draft is threaded four times before threading the left border and the left selvage.

Figure 93 shows a pair of curtains, the border of which is an adaptation of the "Chariot Wheel."

To the one truly interested there is no limitation of adaptations. Whole bedroom sets may be woven, carrying the "Chariot Wheel" into the

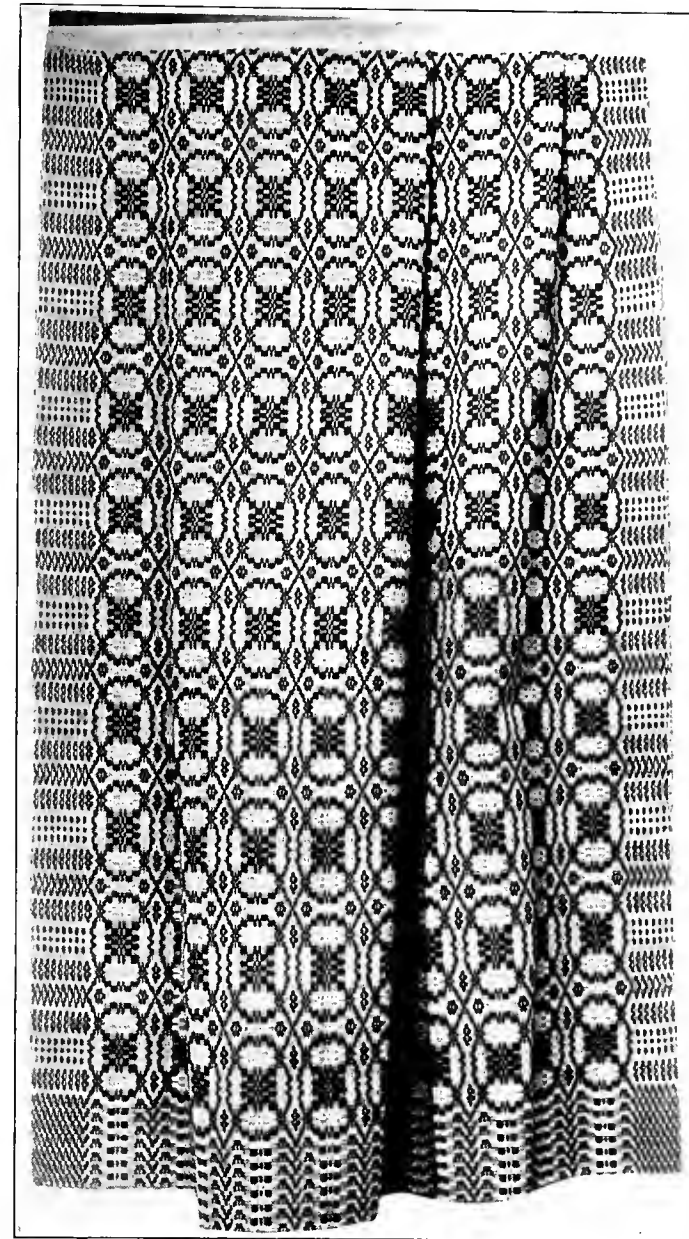


Fig. 92—Counterpane Woven from Chariot Wheel Pattern



Fig. 93—Curtain Woven with Border from Chariot Wheel

various borders. Such a set includes the counterpane, curtains, dressing table mat, valence and even the rug for the floor, which may be woven of coarse materials, carrying out the unity of design.

This particular pair of curtains is woven of Egyptian twine. The border is of two shades of blue No. 3 mercerized cotton.

The loom was threaded 30 ends to the inch. A number 15 reed was used, drawing two threads through each dent. This does not give the scrim weave as shown in the curtains, Figs. 70 and 75, but more of a marquisette weave, which is very pleasing.

When weaving the border use only the treadles which will raise and lower the sets of thread that will produce the one row of wheels. It is well, however, to weave in a narrow stripe below and above the principal border stripe, which in this case is the row of wheels. If the narrow bands are to be used across the top great care must be exercised to get the separate bands exactly the same distance from the top and at the same time make the borders at the bottom come together. If the bands across the top are omitted the weaving of curtains is greatly simplified. It is not necessary to be limited by materials, as almost any threads may be woven into most attractive fabrics.

In weaving curtains it is always well to make a liberal allowance for shrinkage. Almost all materials whether of wool, cotton or linen will shrink.

The Orange Peel

Attention has not been called to the fact that in many cases the original woven pattern appears without the draft for the same. Fig. 94 shows the original pattern of the Orange Peel, while Fig. 95 shows the draft for Fig. 96 and Fig. 97. Should a counterpane of this pattern be desired the threading is done the same as shown in Fig. 95, omitting the left border each time. The number of times the pattern is repeated depends upon the width of the loom and also the width of the couch cover or counterpane desired. It must be remembered that the strips are sewed together and must be made to match.

The weaver will have gained by this time sufficient experience to make the changes to meet the demands. Originality is one of the chief aims of the work.

The draft reads as follows:

Material: Two-ply unbleached carpet warp.

Reed number 15, placing two threads to a dent.

The material used in the pattern (the woof) may be any of the three following materials:

Wool, four-ply carpet warp, or No. 3 mercerized cotton.

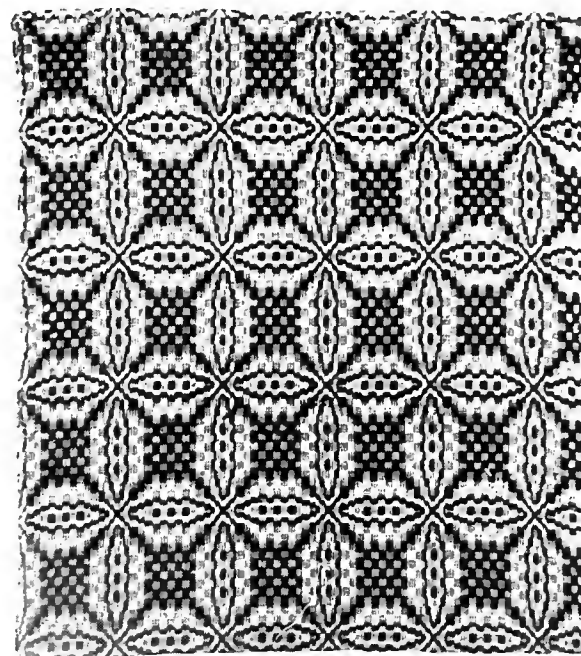


Fig. 94—Original Pattern from Orange Peel

Use a finer thread for the binder.
606 threads for the complete pattern.
Each lower heddle stick is tied to a lamb.
The lambs are tied as follows:
2 and 4 to the first treadle.
2 and 3 to the second treadle.
1 and 3 to the third treadle.
1 and 4 to the fourth treadle.
For the plain weave tie:
1 and 2 to the right middle treadle.
3 and 4 to the left middle treadle.

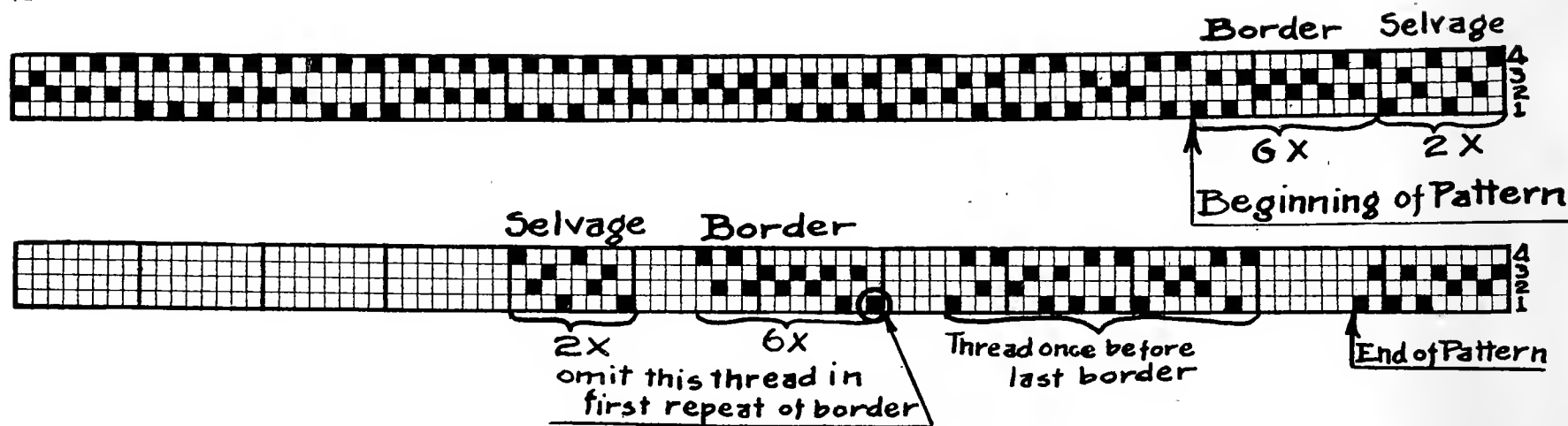


Fig. 95—The Orange Peel. Draft of Pattern

This pattern has a few irregularities. First the selvage is threaded and then the right border. The pattern is then threaded five times from one arrow to the other. After the fifth threading the threads within the brace marked "thread once before last border" are taken care of. After this the last border is threaded, omitting the first thread in the first repeat of the border. This is done to avoid two threads coming together on the first heddle stick. The threading of the left border completes the pattern.

It will be observed that the right and left edges are not the same, only half the pattern showing on the right edge and almost a complete pattern on the left edge.

Figure 96 shows the "Orange Peel" worked out

in a sofa pillow top. The draft shown at Fig. 95 will make this pillow top.

Figure 97 shows the under side of Fig. 96.

Governor's Garden

Figure 98 gives the draft for a pillow top or table runner taken from the "Governor's Garden" shown in Fig. 99.

It is difficult to recognize Figs. 97 and 98 as having been taken from Fig. 99.

It is quite wonderful what even the amateur weaver will be able to do after a somewhat limited experience in actual work with the loom.

Any draft is full of suggestions for borders, curtains, table runners, complete couch covers, pillow tops, counterpanes, etc.

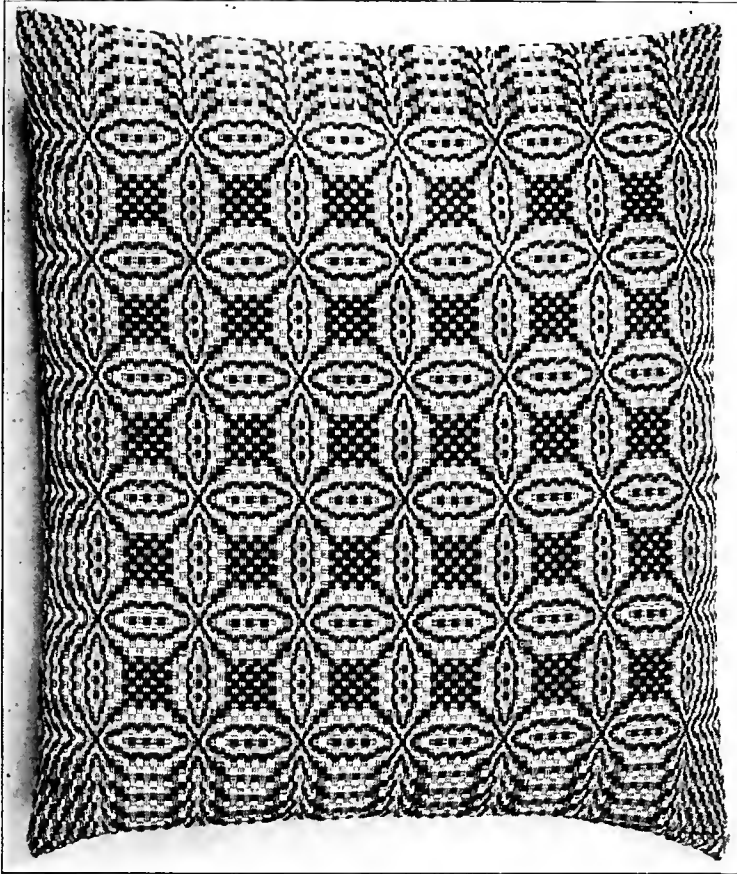


Fig. 96—Pillow Top Woven from Orange Peel

The "Governor's Garden" is the longest of the drafts and is threaded just as given in Fig. 98.

The draft reads as follows:

Materials: Two-ply unbleached carpet warp.

Reed: Number 15, placing two threads to a dent.

The material in the pattern (woof) may be any of the materials before mentioned.

Use 716 threads for the complete pattern. Each lower heddle stick is tied to a lamb.

The lambs are tied as follows:

1 and 4 to the first treadle.

1 and 2 to the second treadle.

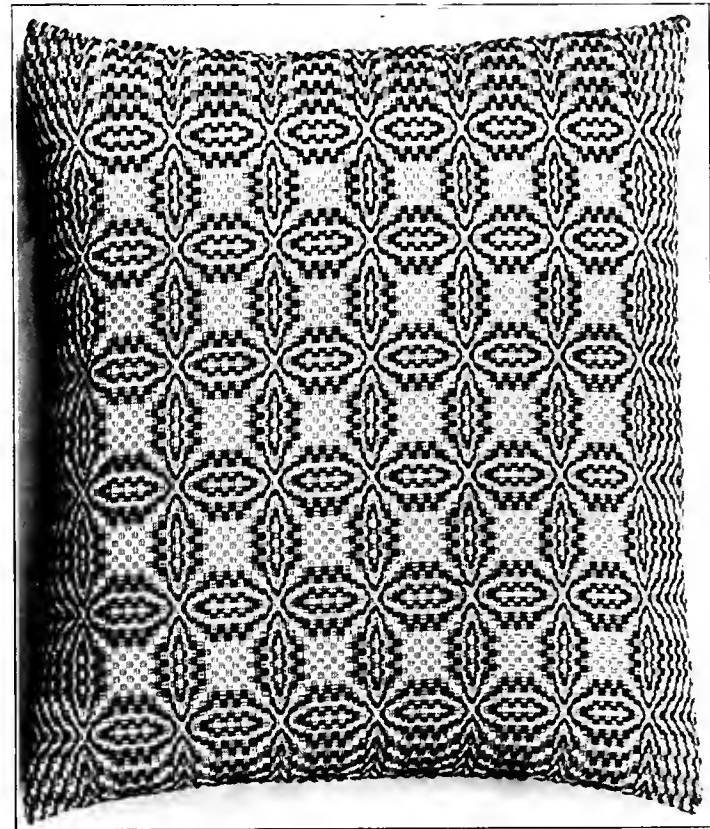


Fig. 97—Under Side of Pillow shown in Fig. 96

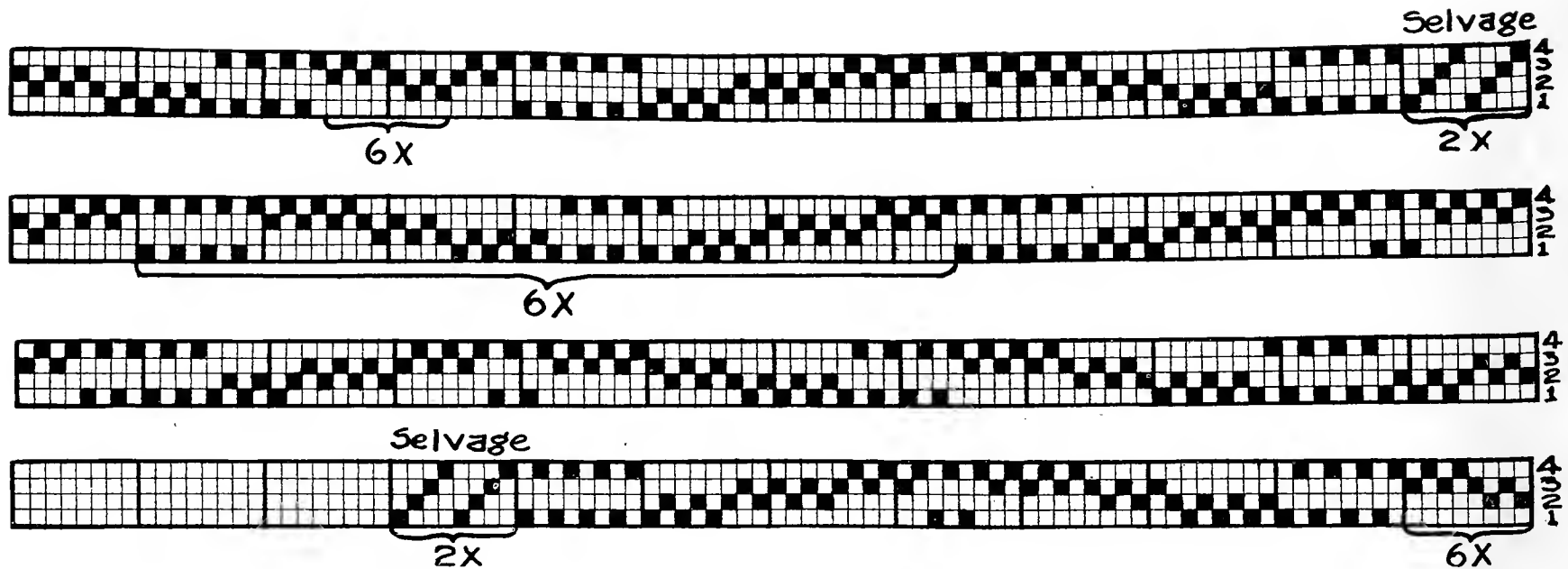


Fig. 98—The "Governor's Garden." Draft of Pattern

2 and 3 to the third treadle.

3 and 4 to the fourth treadle.

For the plain weave tie:

1 and 3 to the right middle treadle.

2 and 4 to the left middle treadle.

Figure 100 shows the right side of the finished weaving, while Fig. 101 shows the under side.

The border on the front and back edges of any weaving is always taken care of by weaving the repeat of the border as many times as is suggested in the draft.

Bonaparte's March

Figure 103 shows the woven sample of Bona-

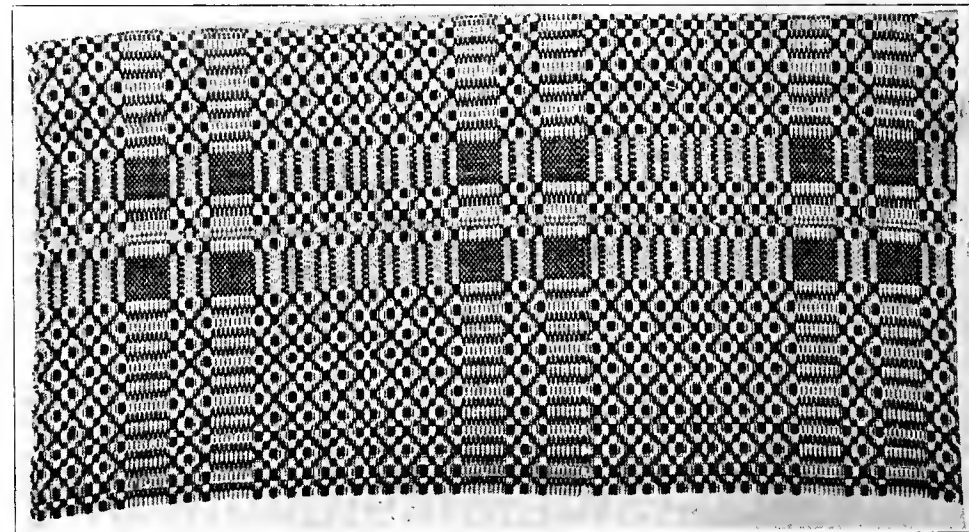


Fig. 99—Original Pattern of Governor's Garden

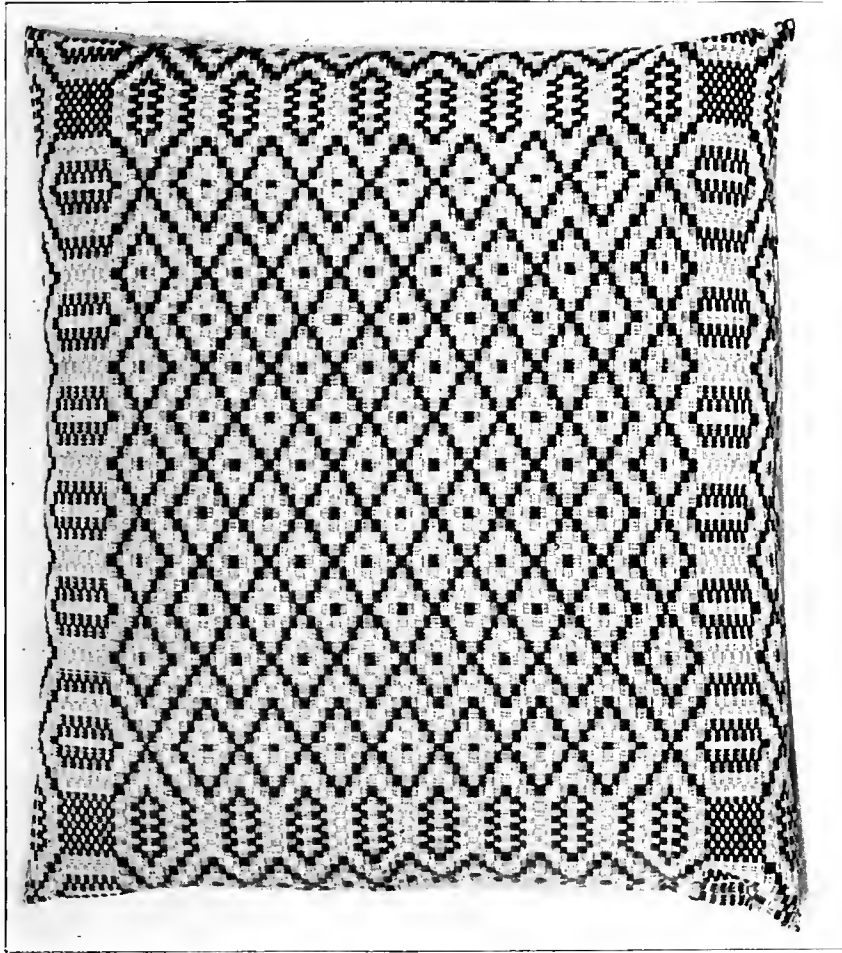


Fig. 100—Pillow Top Woven from Governor's Garden

parte's March. It was woven by following the draft shown at Fig. 102. In weaving the old-time counterpanes it was necessary to weave them in two strips because of the width of the looms at that

time. In order that the two strips might be sewed together, the pattern was begun in the center of some particular figure found in the pattern.

Only four threads were used in the selvage along the left edge. The border was usually placed on the right edge.

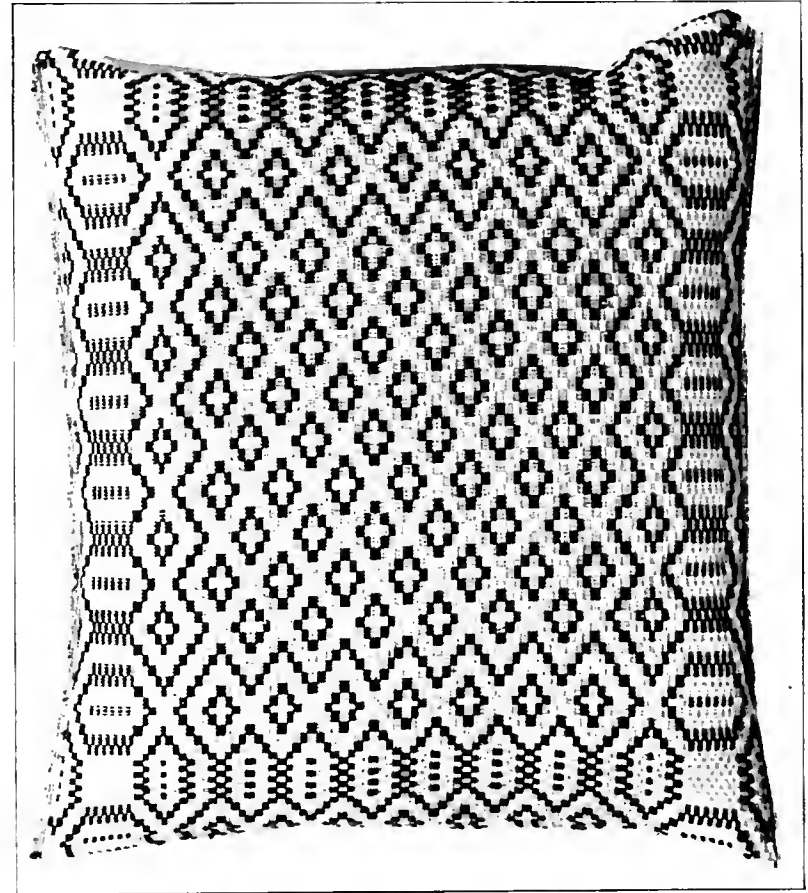


Fig. 101—Under Side of Pillow shown in Fig. 100

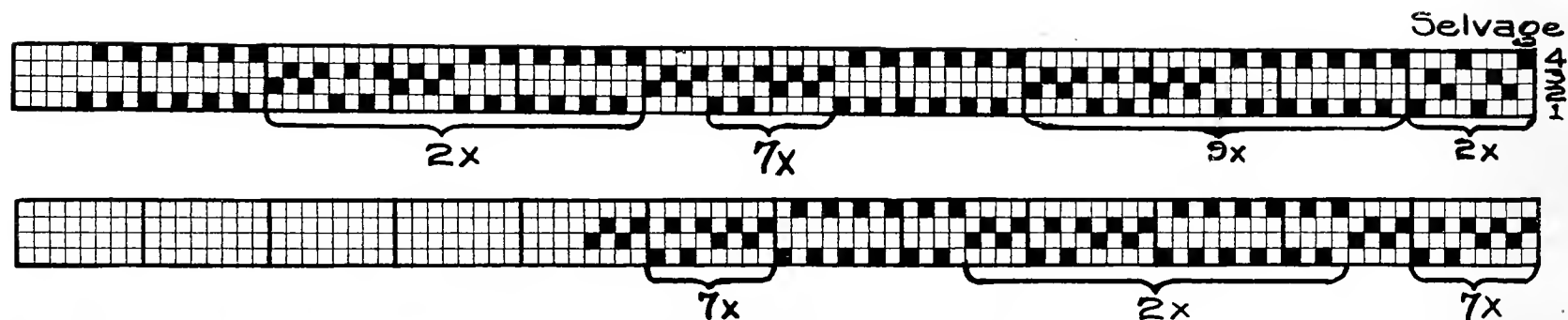


Fig. 102—Bonaparte's March. Draft of Pattern

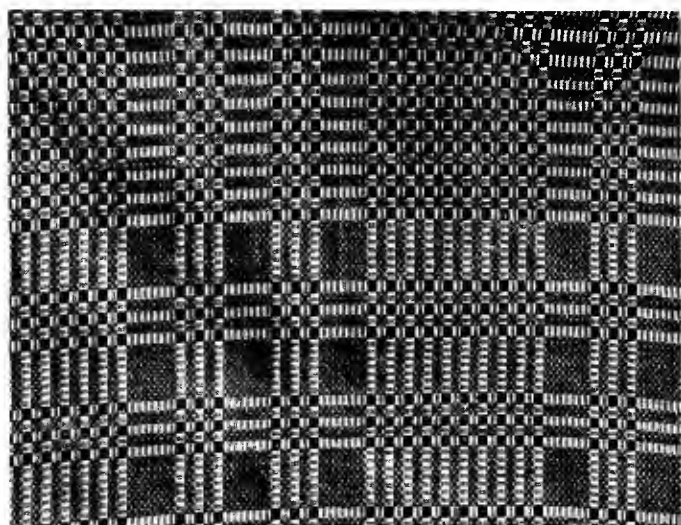


Fig. 103—Original Pattern of Bonaparte's March

Borders

Borders are made by repeating certain sets of threads a number of times. Any one at all familiar with pattern weaving can readily understand the making of borders.

Figure 104 shows a draft taken from draft 102. It is that part of the draft that will make an interesting pillow top.

Figure 102 reads as follows:

Count the number of threads in the pattern. Each lower heddle stick is tied to a lamb. The lambs are tied as follows:
1 and 4 to the first treadle.

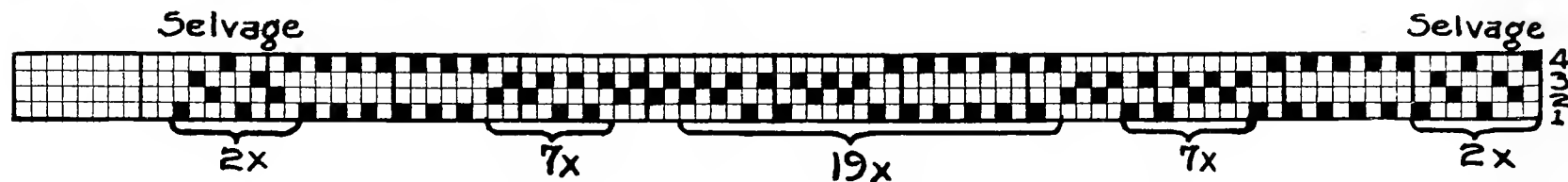


Fig. 104—Draft of Pattern for Pillow Top. Adaptation of Bonaparte's March

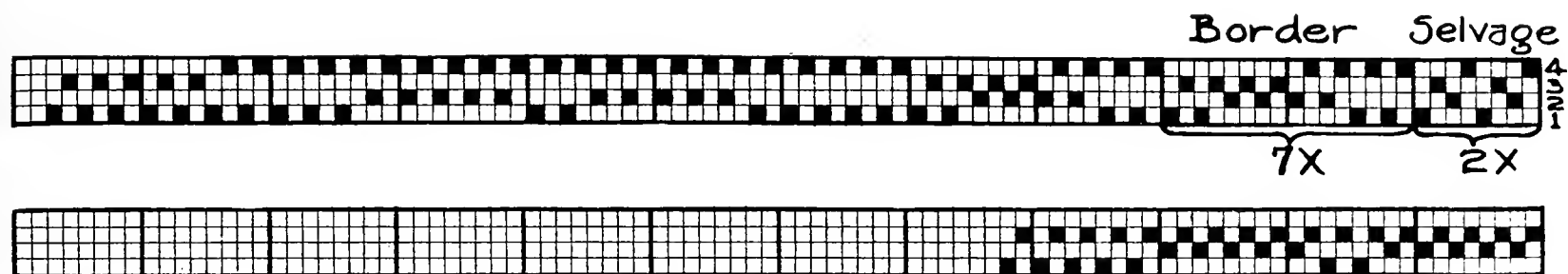


Fig. 105—The Snail's Trail and Cat's Paw. Draft of Pattern

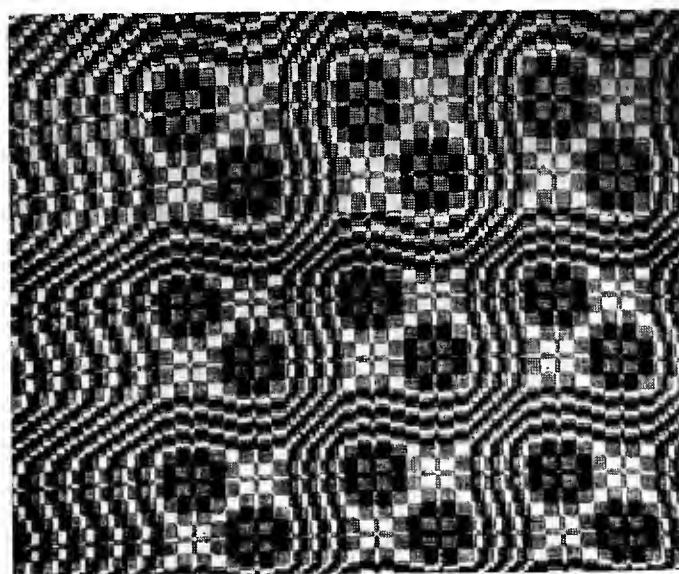


Fig. 106—Original Pattern, Snail's Trail and Cat's Paw

2 and 3 to the second treadle.

1 and 3 to the third treadle.

It will be observed that only three treadles are necessary to weave the pattern.

The plain weave is done by tying lambs:

1 and 2 to the right middle treadle.

3 and 4 to the left middle treadle.

The material may be any of the material before mentioned.

Figure 104 may be read and the treadles tied the same as described in Fig. 102.

Snail's Trail

Figure 105 shows the draft for the pattern shown in Fig. 106. This pattern is often called the "Snail's Trail" and "Cat's Paw."

Each lower heddle stick is tied to a lamb.

The lambs are tied as follows:

1 and 4 to the first treadle.

2 and 4 to the second treadle.

2 and 3 to the third treadle.

1 and 3 to the fourth treadle.

The plain weave is done by tying lambs:

Selvage

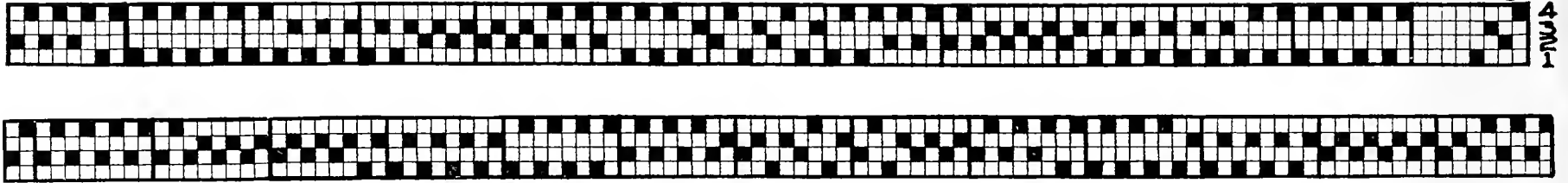


Fig. 107—The Blooming Flower. Draft of Pattern

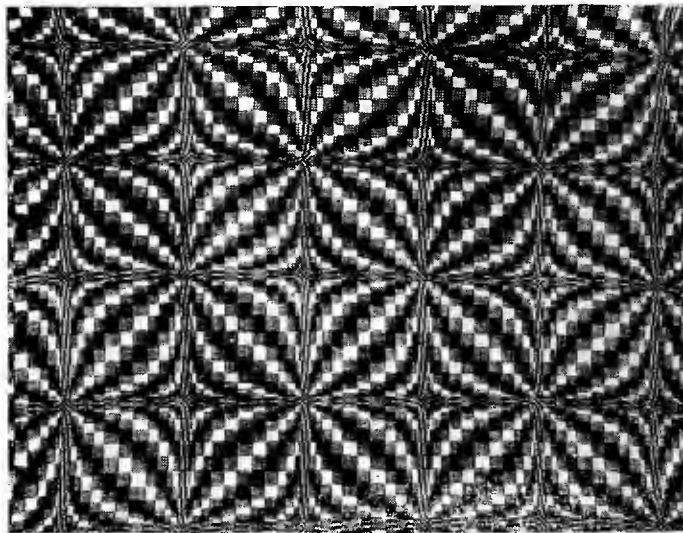


Fig. 108—Original Pattern, Blooming Flower

1 and 2 to the right middle treadle.

3 and 4 to the left middle treadle.

Press the treadles in the order indicated by the draft and as before described.

The Blooming Flower

“The Blooming Flower” is a pattern often used for counterpanes. Fig. 107 shows the draft while

Fig. 108 shows the pattern woven by following the draft, Fig. 107. Only four threads are suggested in the selvage. This will permit of the sewing together of the two strips.

The material is usually a two-ply carpet warp for the warp and wool for the woof. Each lower heddle stick is tied to a lamb.

For the pattern the lambs are tied as follows:

1 and 4 to the first treadle.

1 and 3 to the second treadle.

2 and 3 to the third treadle.

2 and 4 to the fourth treadle.

The plain weaving is done by tying lambs:

1 and 2 to the right middle treadle.

2 and 4 to the left middle treadle.

Pine Knot

Figure 109 shows the draft for “The Pine Knot” and Fig. 110 shows the woven sample. This pattern lends itself to several interesting combinations.

If the weaver has read what has gone before

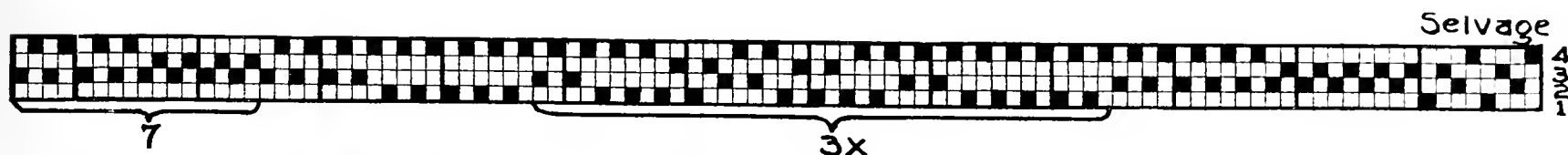


Fig. 109—Pine Knot. Draft of Pattern

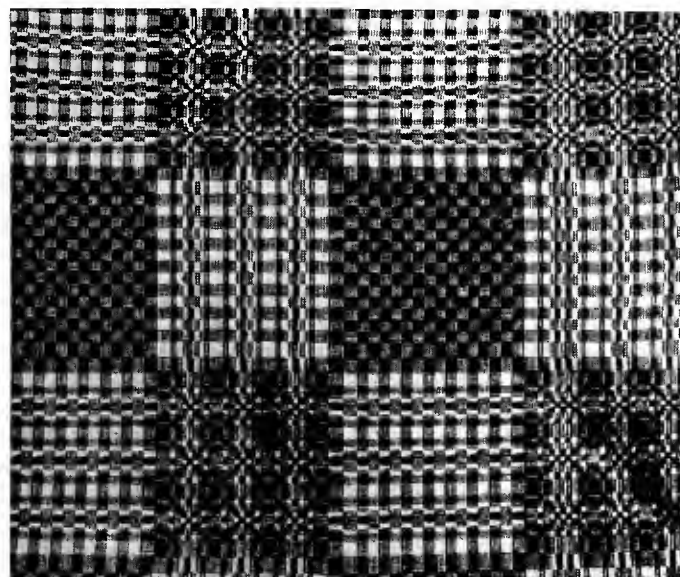


Fig. 110—Original Pattern, Pine Knot

there will be no difficulty by this time to select such parts of the pattern as are desired.

The draft reads as follows:

Tie each lower heddle stick to a lamb. The lambs are tied as follows:

2 and 3 to the first treadle.

2 and 4 to the second treadle.

1 and 4 to the third treadle.

1 and 3 to the fourth treadle.

The plain weave is done by tying lambs:

1 and 2 to the right middle treadle.

3 and 4 to the left middle treadle.

It must not be forgotten that the lambs are not absolutely necessary. Each treadle may be tied

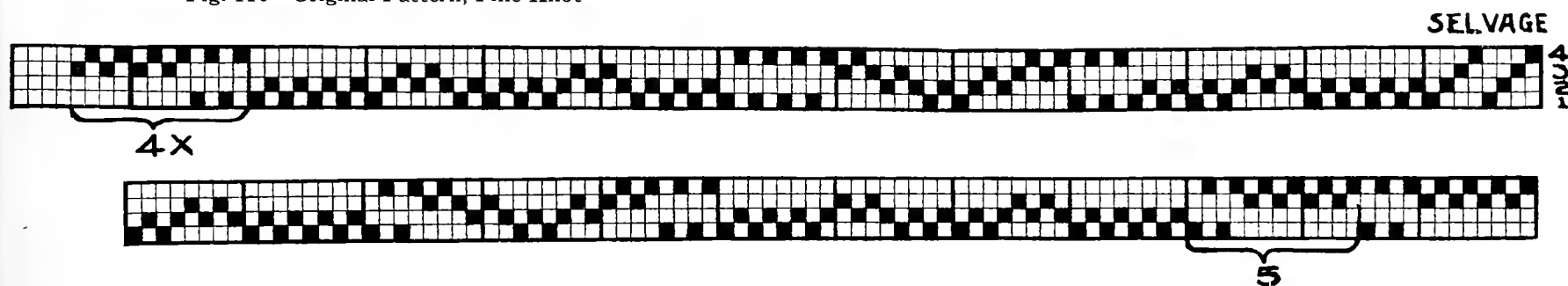


Fig. 111—Federal Knot. Draft of Pattern

directly to the lower heddle stick. In such a case only four treadles are used but two are pressed down each time a thread is passed through the shed. This has already been described.

Federal Knot

Fig. 111 shows the draft for the "Federal Knot" and Fig. 112 shows the woven sample. This pattern, the same as those previously described, is full of suggestions.

The material before mentioned may again be used in this pattern.

The draft reads as follows:

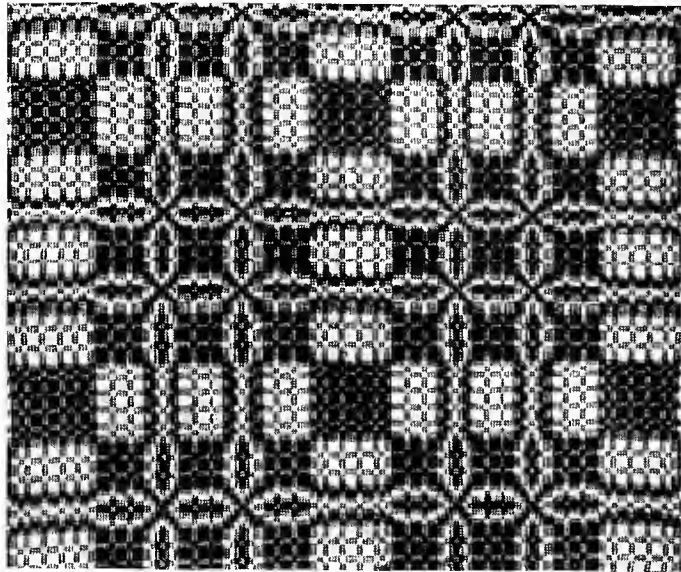


Fig. 112—Original Pattern, Federal Knot

Tie each lower heddle stick to a lamb.

The lambs are tied as follows:

1 and 4 to the first treadle.

3 and 4 to the second treadle.

1 and 2 to the third treadle.

2 and 3 to the fourth treadle.

The plain weave is done by tying lambs:

1 and 3 to the right middle treadle.

2 and 4 to the left middle treadle.

Wheel of Fortune

Figure 113 shows the draft for what is known as the "Wheel of Fortune," sometimes called the "Wheel of Time."

The draft reads as follows: Material 2, 3, or 4-ply unbleached carpet warp for the warp.

The material used in the pattern (the woof) may be any one of the materials already mentioned.

For 2-ply carpet warp use a No. 15 reed, for 3-ply use a No. 12 reed, for 4-ply use a No. 10 reed.

It requires 262 threads for one repeat of the pattern. The selvage requires eight threads; and the border for a counterpane, 160 threads. If a pillow top is to be made the border should be made narrower and on both edges. The pattern begins at the first arrow just after the selvage and ends at the other arrow just before the border.

Tie-up: Each lower heddle stick is tied to a lamb.

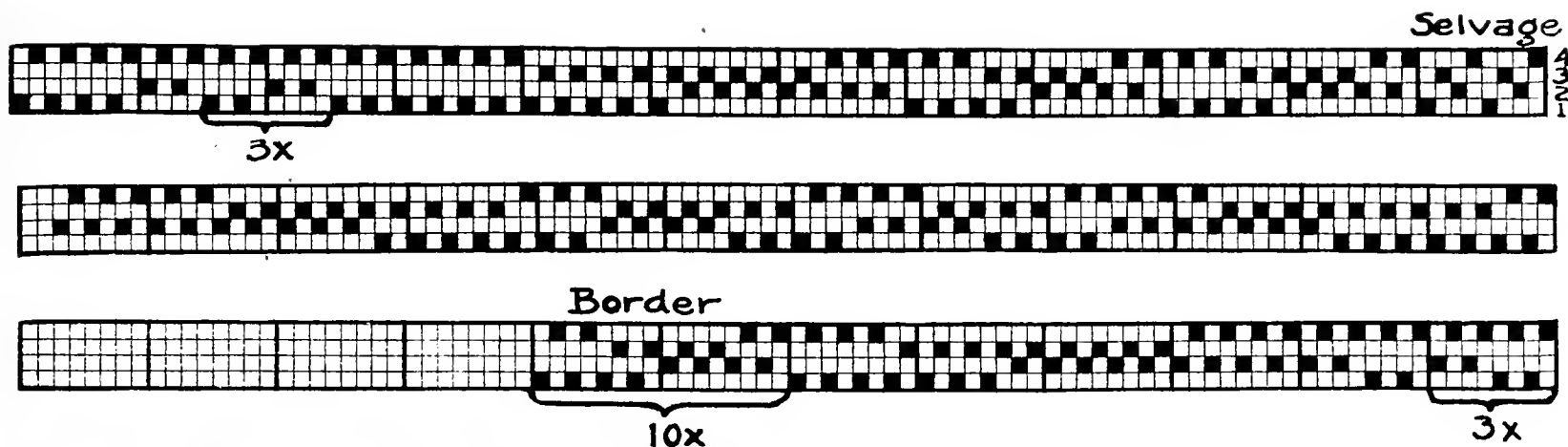


Fig. 113—Wheel of Fortune. Draft of Pattern

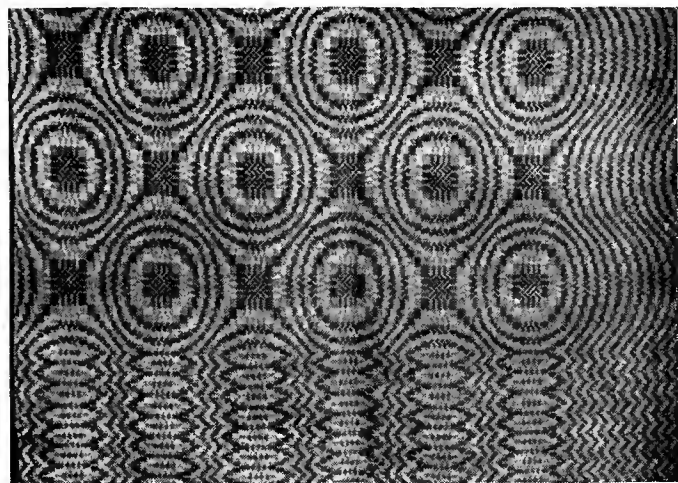


Fig. 114—Wheel of Fortune. Original Pattern.

The lambs are tied as follows:
 2 and 4 to the first treadle.
 2 and 3 to the second treadle.

1 and 3 to the third treadle.

1 and 4 to the fourth treadle.

For the plain weave tie:

1 and 2 to the right middle treadle.

3 and 4 to the left middle treadle.

The weaver must always remember that a great deal of judgment must be exercised when doing the weaving.

Four treadles may be used, one tied to each lower treadle stick. In such a case two treadles must be pressed down at the same time. Almost any kind of material may be adapted to the work. When the material is coarse there must be fewer threads to the inch.

Figure 114 shows the finished weaving.

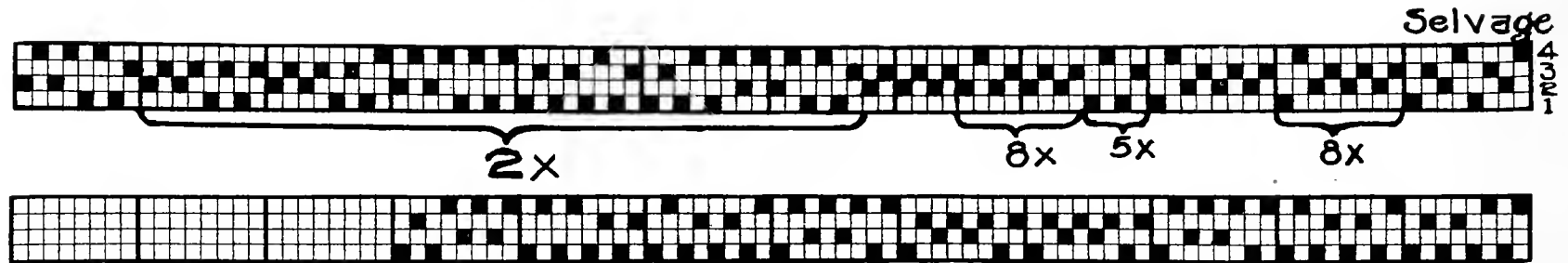


Fig. 115—The Irish Chain. Draft of Pattern

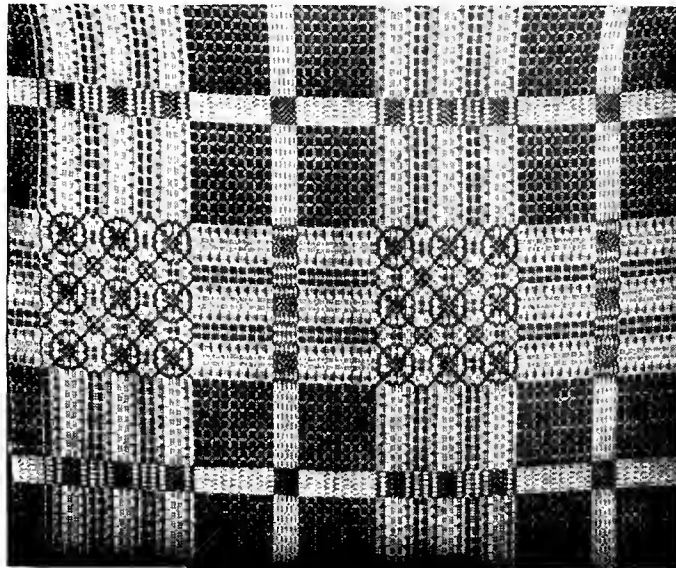


Fig. 116—Irish Chain. Original Pattern.

Irish Chain

The "Irish Chain," sometimes called the "Nine Wheels," and sometimes the "Nine Snow Balls," is shown in Fig. 116.

The draft for the "Irish Chain" is shown in Fig. 115.

The draft reads as follows:

Material: Two-ply unbleached warp. The material used in the pattern (woof) may be any one of the materials already mentioned.

Number 15 reed, placing two threads to a dent, 288 threads required to complete one repeat of the pattern.

The Tie-Up

The lower heddle sticks are tied one to each lamb.

The lambs are tied as follows:

2 and 3 to the first treadle.

2 and 4 to the second treadle.

1 and 4 to the third treadle.

1 and 3 to the fourth treadle.

For the plain weave:

1 and 2 to the right middle treadle.

2 and 4 to the left middle treadle.

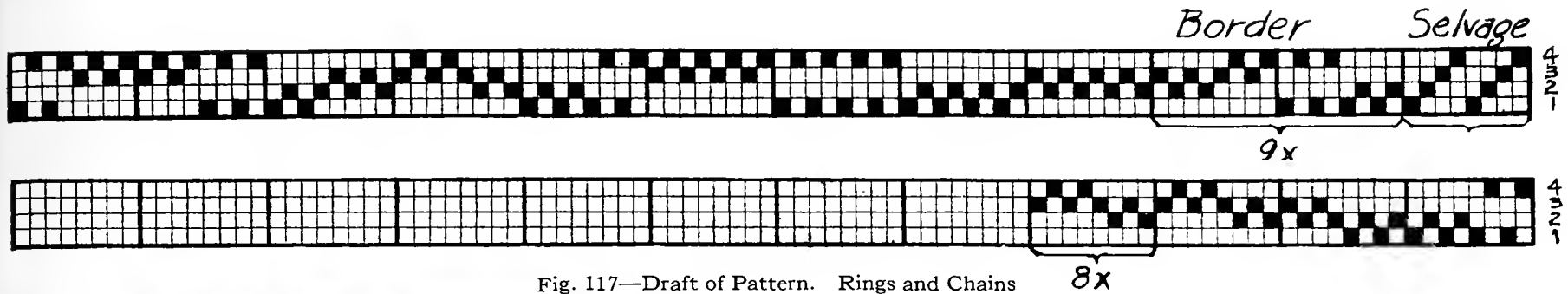


Fig. 117—Draft of Pattern. Rings and Chains

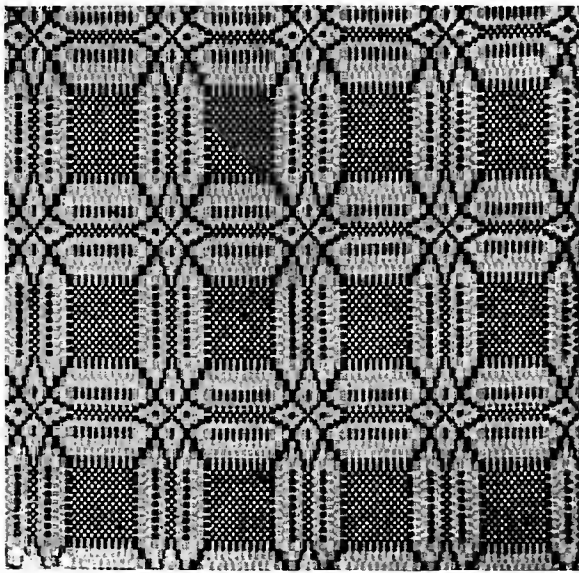


Fig. 118—Rings and Chains, Original Pattern

Figure 118 shows the original pattern woven by following the draft shown in Fig. 117, without the border. A counterpane or couch cover is not quite complete if left without a border. Fig. 119 shows a counterpane with border. Fig. 117 shows the complete draft for the same.

The same draft may be used for a pillow top or table runner by threading the border fewer times and repeating it and the selvage along the left side.

The amateur weaver has no doubt discovered by this time that any border consists only of a certain number of threads of each combination repeated a number of times, the number of repeats depending entirely upon the width of the border desired.

The front border is always produced by following the draft shown within the brace marked "border," repeating the weaving as many times as is indicated.

Upon examination it is found that to produce the finished piece of cloth the pattern treadles are tied as follows:

The lower heddle sticks are tied one to each lamb.

Treadles 1 and 2 are tied to the first lamb.

Treadles 1 and 4 are tied to the second lamb.

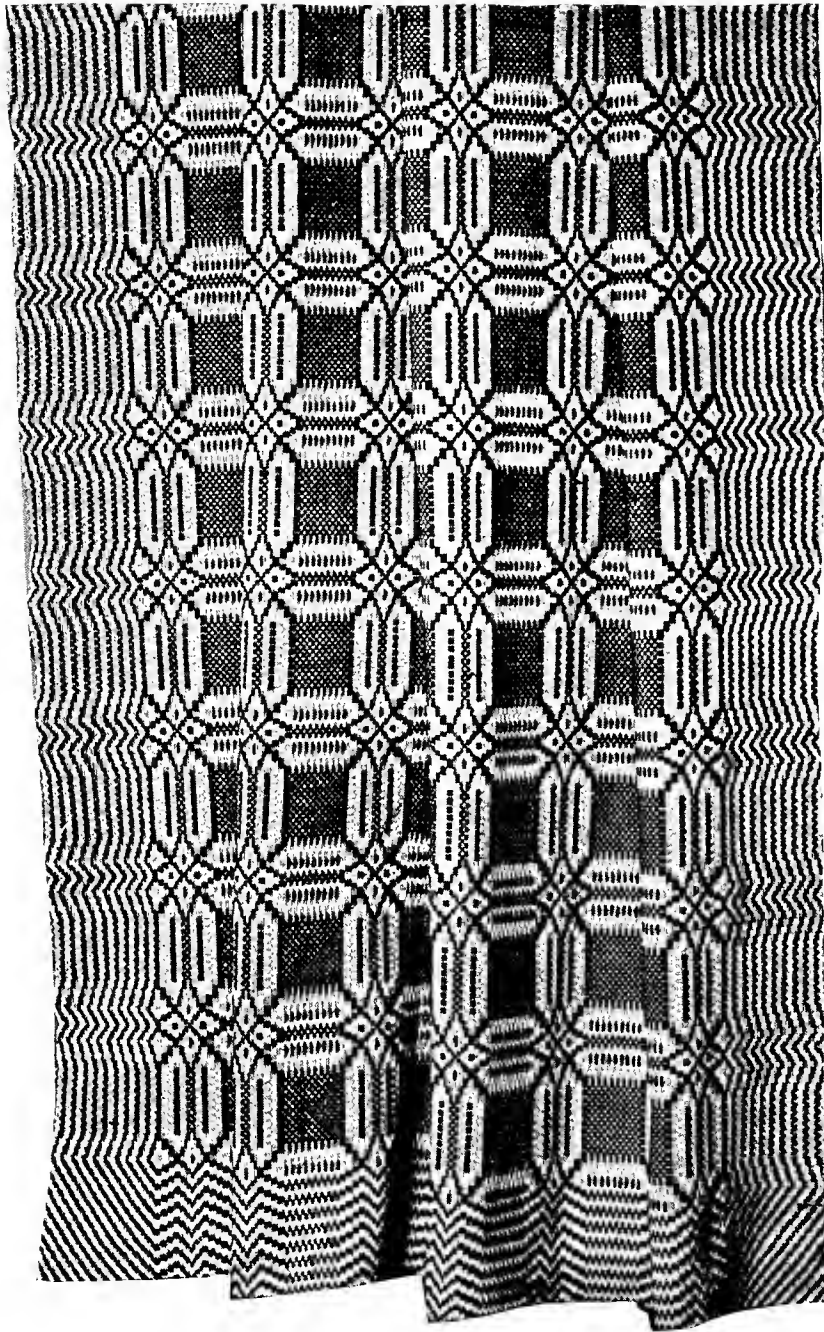


Fig. 119—Counterpane Woven from Rings and Chains

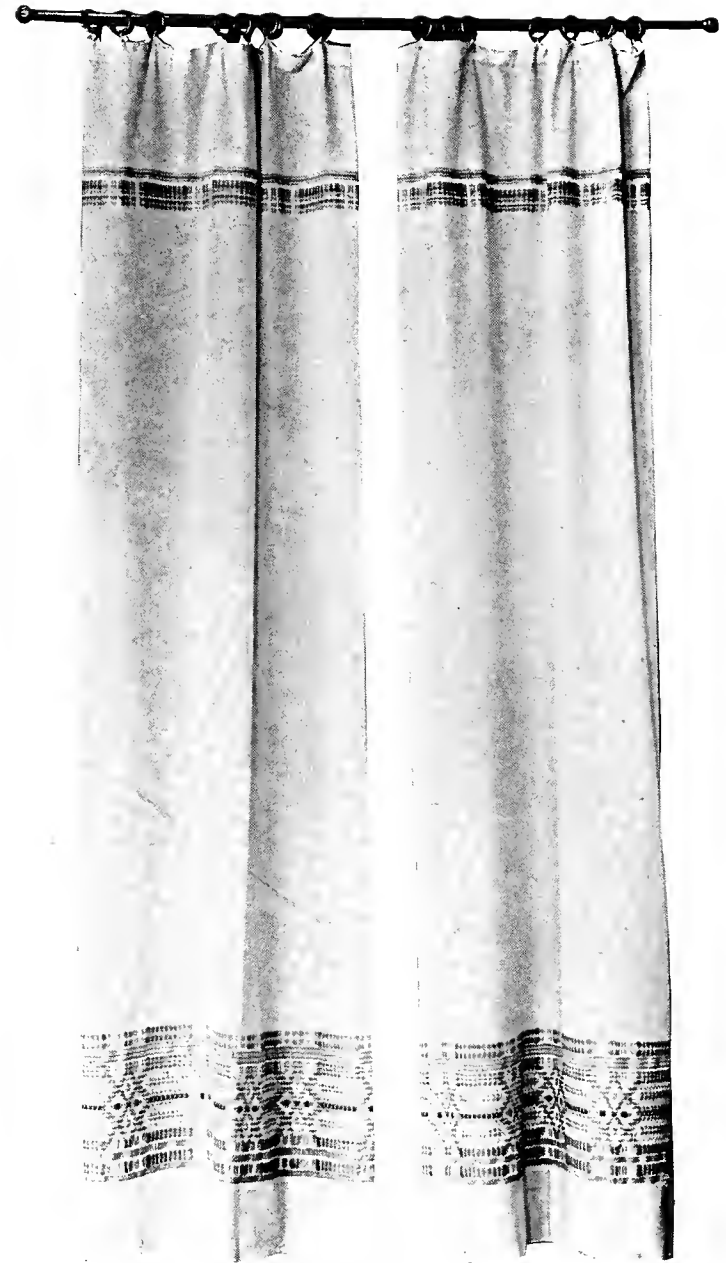


Fig. 120—Curtains with Border from Rings and Chains

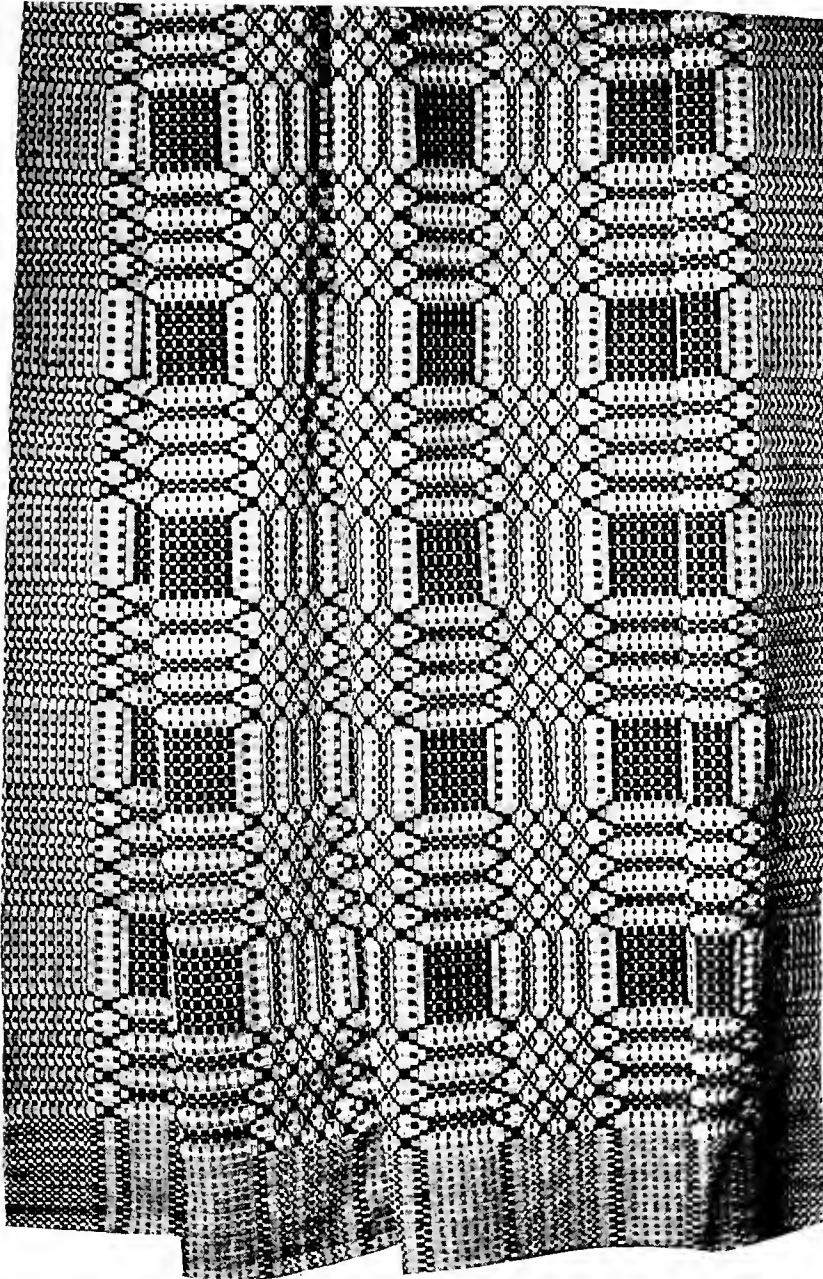


Fig. 121—Counterpane Woven from Old Quilt Pattern

Treadles 3 and 4 are tied to the third lamb.

Treadles 2 and 3 are tied to the fourth lamb.

Plain weave:

Treadles 1 and 3 are tied to the right middle treadle.

Treadles 2 and 4 are tied to the left middle treadle.

The materials used are similar to those previously suggested for other patterns.

Figure 120 shows a pair of curtains woven of Egyptian twine. The border is an adaptation of "Rings and Chains." The part used in the border may easily be found in the completed counterpane, Fig. 119. The threading for the border in the curtains is the same as shown in Fig. 117. In weaving only the treadles are used that will produce the borders shown in the curtains.

Old Quilt Pattern

The finished counterpane shown in Fig. 121 was woven by following the draft shown in Fig. 122.

The name of this particular pattern is unknown to the author. The draft was taken from an old counterpane belonging to Miss Elizabeth Gauger, of Joliet, Ill.

Each lower heddle stick is tied to a lamb.

The treadles are tied as follows:

Treadles 1 and 2 are tied to the first lamb.

Treadles 2 and 3 are tied to the second lamb.

Treadles 3 and 4 are tied to the third lamb.

Treadles 1 and 4 are tied to the fourth lamb.

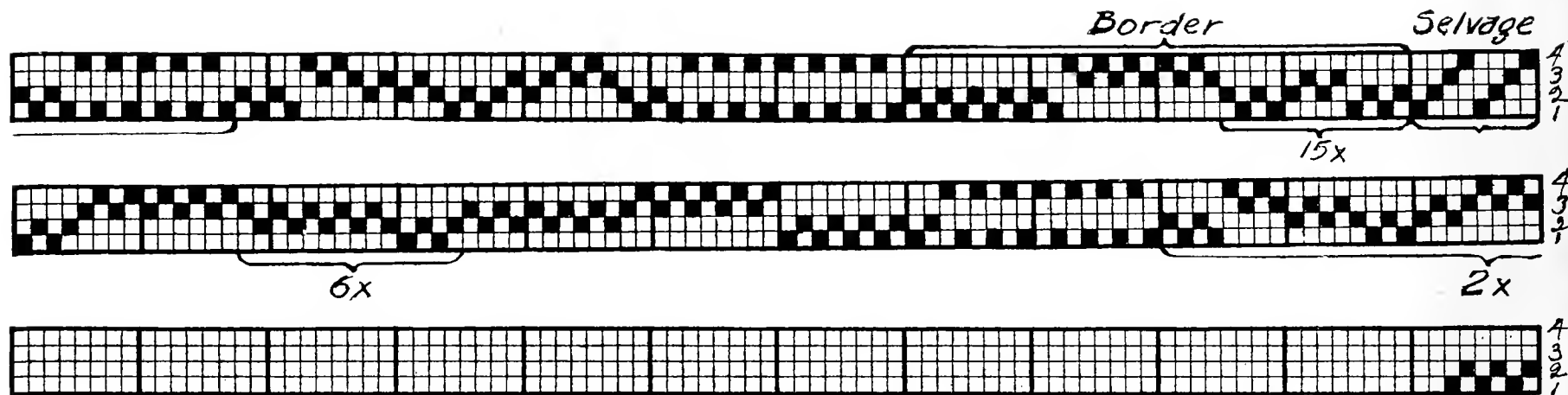


Fig. 122—Old Quilt Pattern. Draft of Pattern

Plain weave:

Lambs 1 and 3 are tied to the right middle treadle.

Lambs 2 and 4 are tied to the left middle treadle.

Other Patterns

The amateur weaver has, no doubt, learned by this time just how to read each draft. It has already been stated that the draft tells the whole story.

The lambs are always tied one to each lower heddle stick.

The treadles are now tied to the lambs. Fig. 76 suggests the way the draft may be divided in

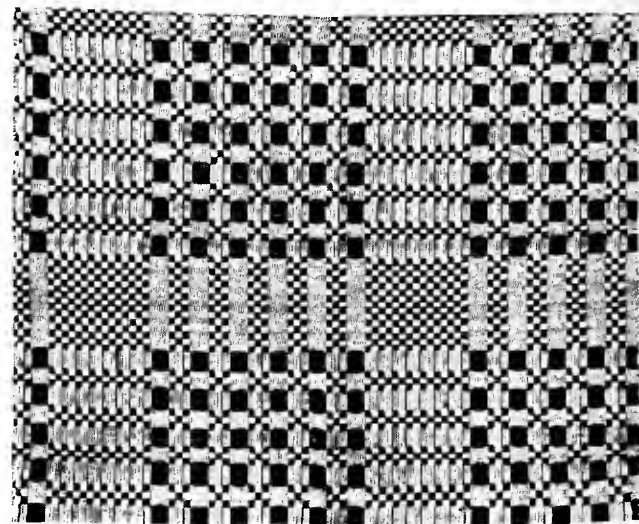


Fig. 123—Leopard Skin. Original Pattern

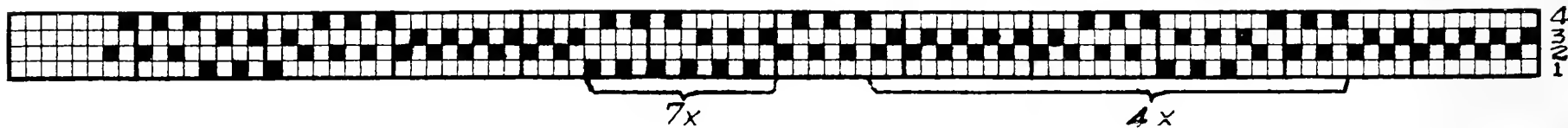


Fig. 124—Leopard Skin. Draft of Pattern

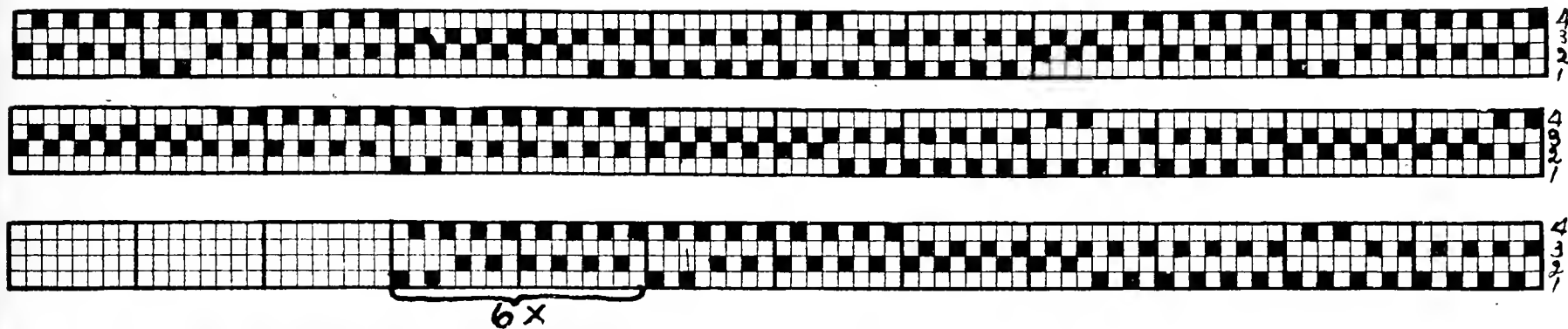


Fig. 125—Fox Trail. Draft of Pattern

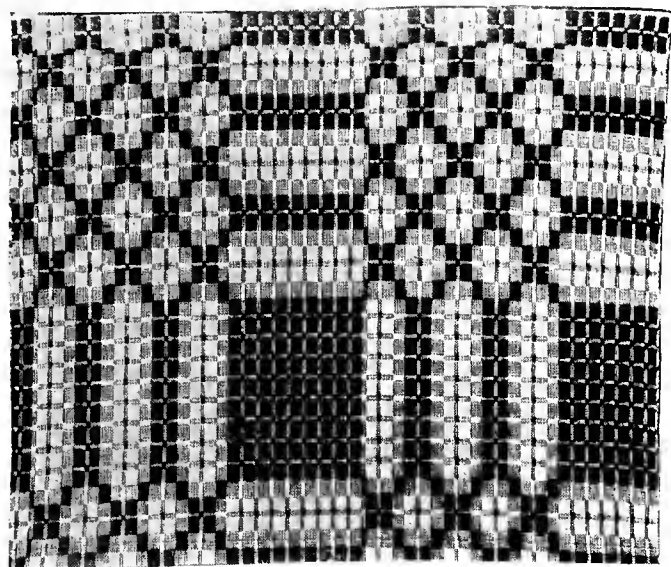


Fig. 126—Fox Trail. Original Pattern

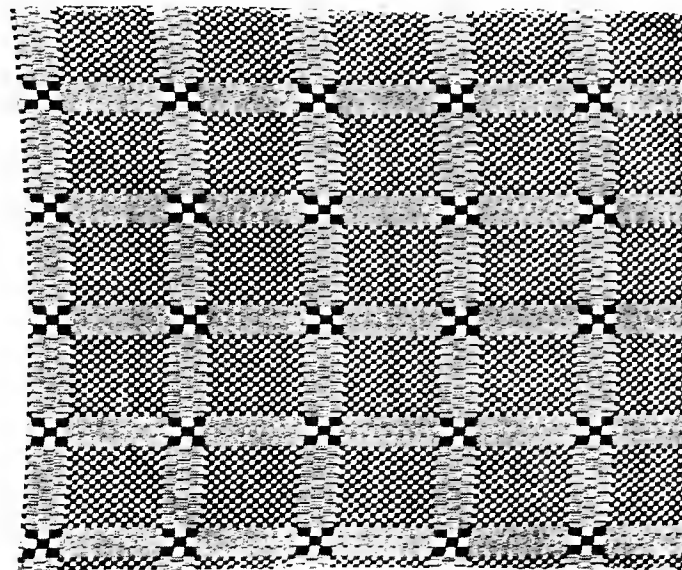


Fig. 127—Doors and Windows. Original Pattern

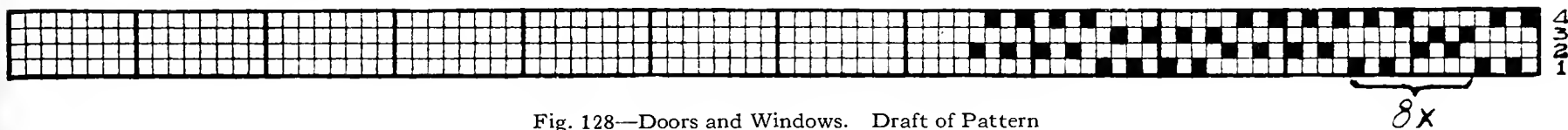


Fig. 128—Doors and Windows. Draft of Pattern

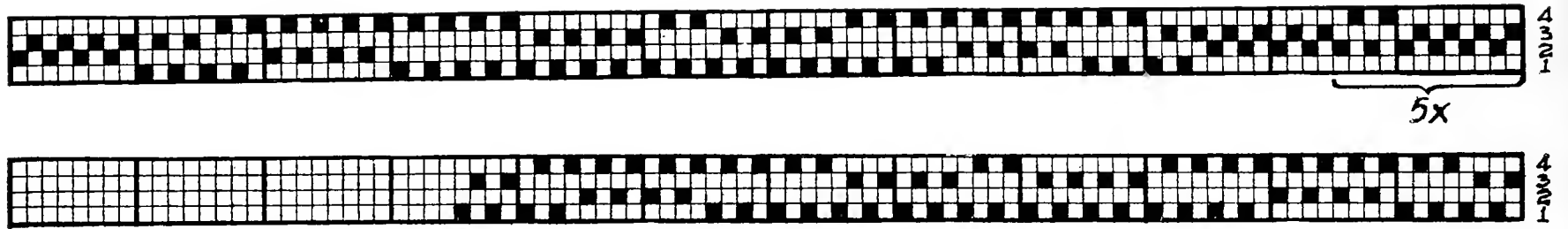


Fig. 129—Double Chariot Wheels. Draft of Pattern

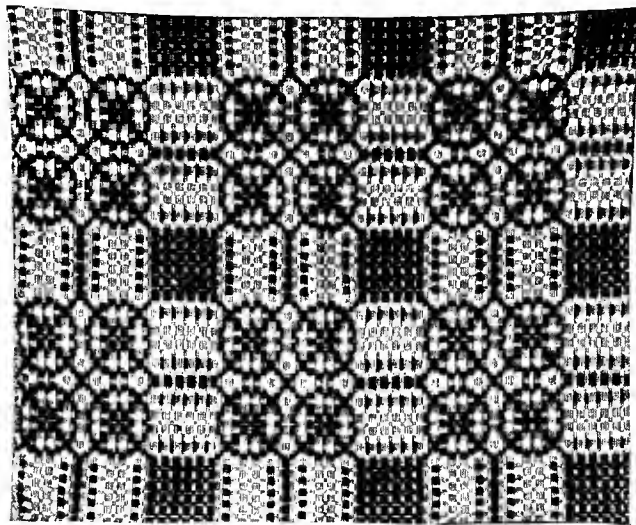


Fig. 130—Double Chariot Wheels. Original Pattern

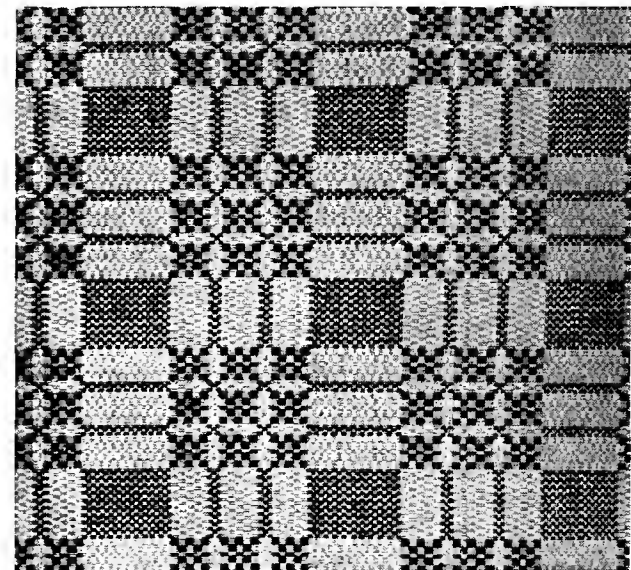


Fig. 131—Scarlet Balls. Original Pattern

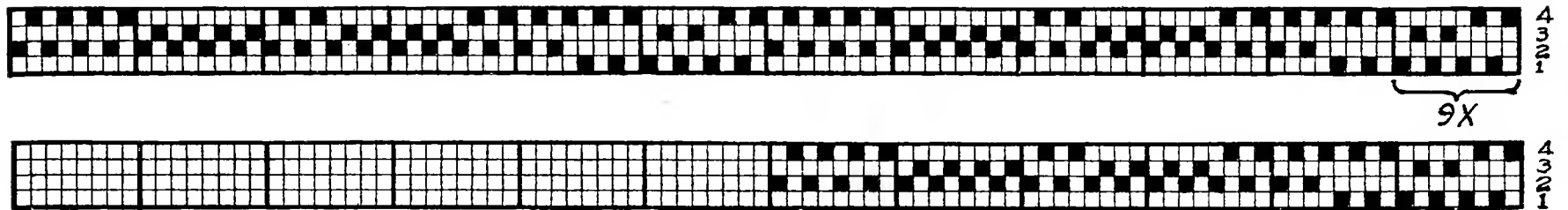


Fig. 132—Scarlet Balls. Draft of Pattern

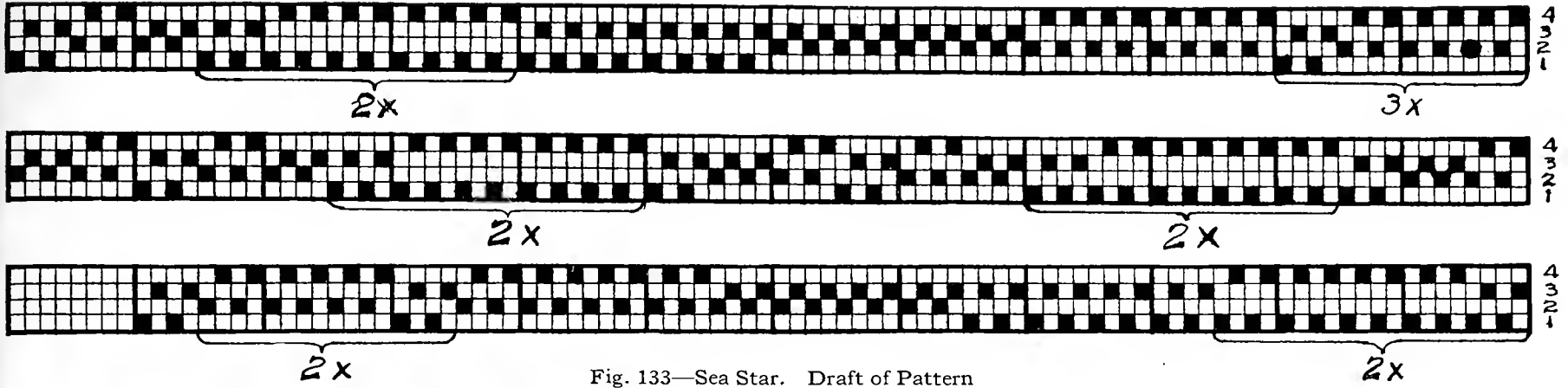


Fig. 133—Sea Star. Draft of Pattern

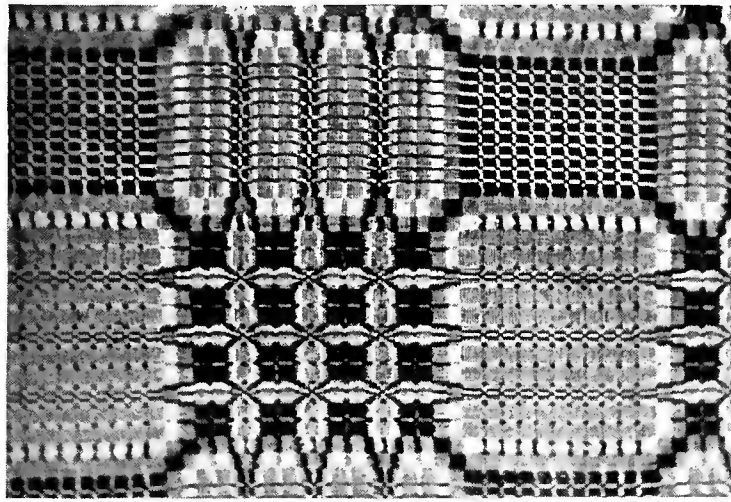


Fig. 134—Sea Star. Original Pattern

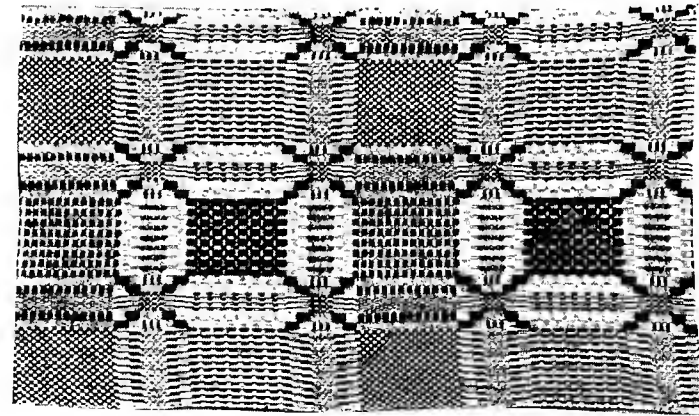


Fig. 135—The White House. Original Pattern

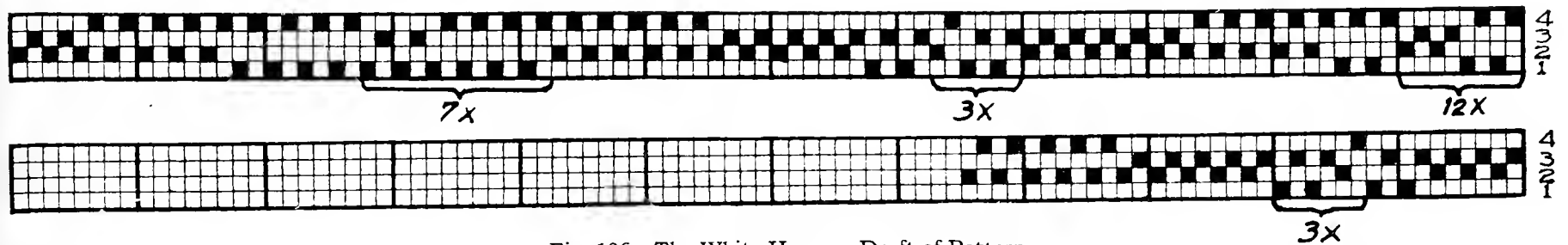


Fig. 136—The White House. Draft of Pattern

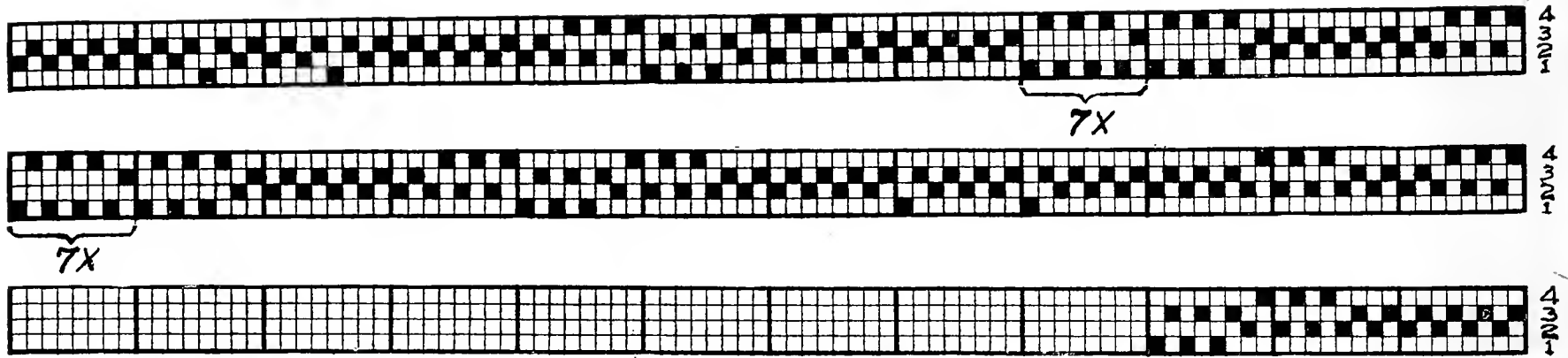


Fig. 137—The Indiana Frame Rose. Draft of Pattern

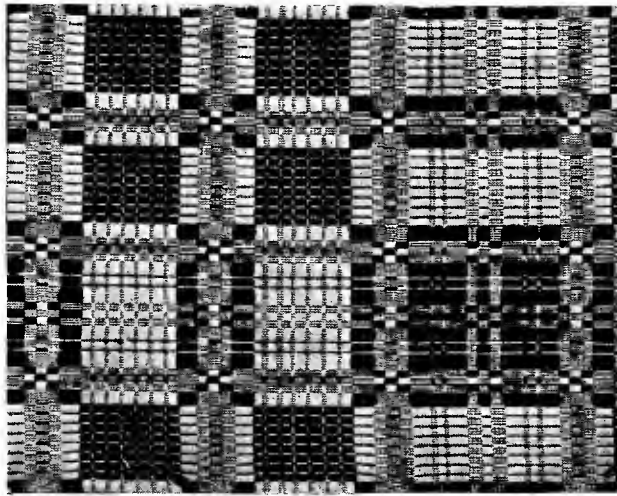


Fig. 138—The Indiana Frame Rose. Original Pattern

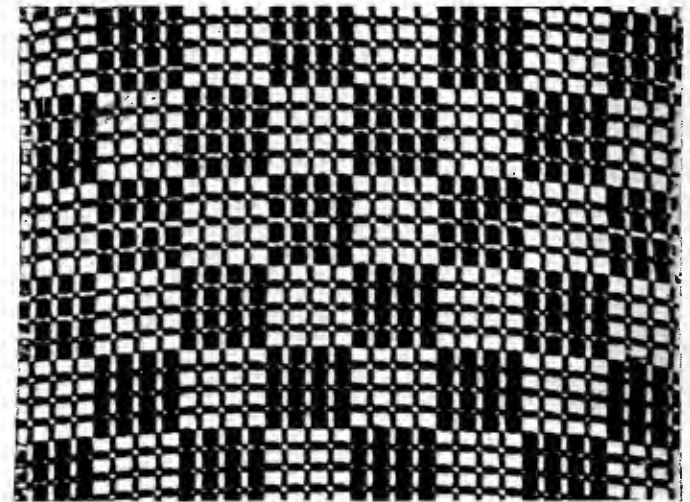


Fig. 139—Window Sash. Original Pattern

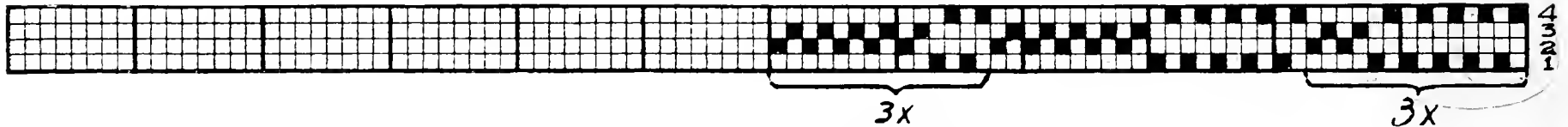


Fig. 140—Window Sash. Draft of Pattern

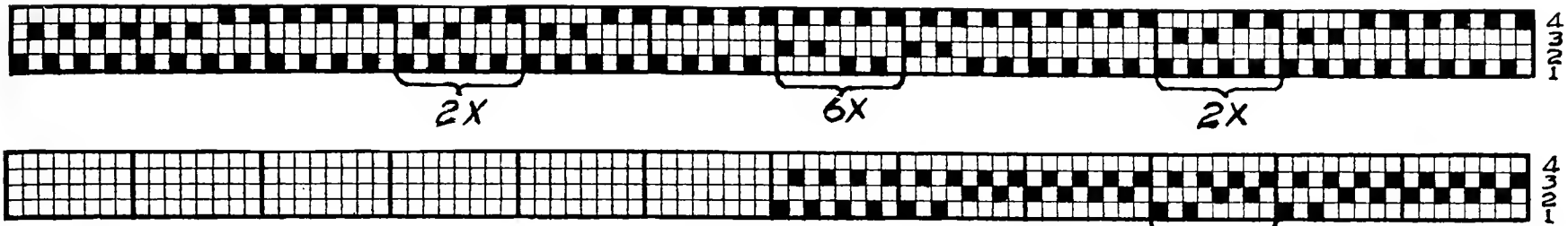


Fig. 141—Parson's Beauty. Draft of Pattern

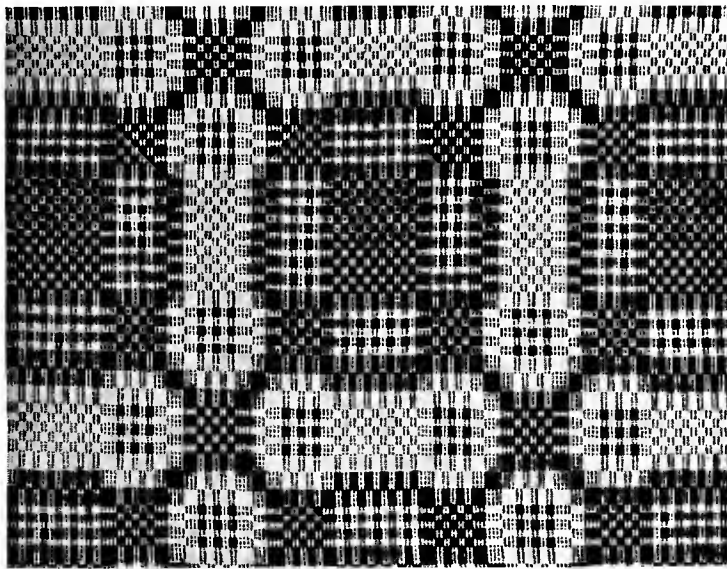


Fig. 142—Parson's Beauty. Original Pattern

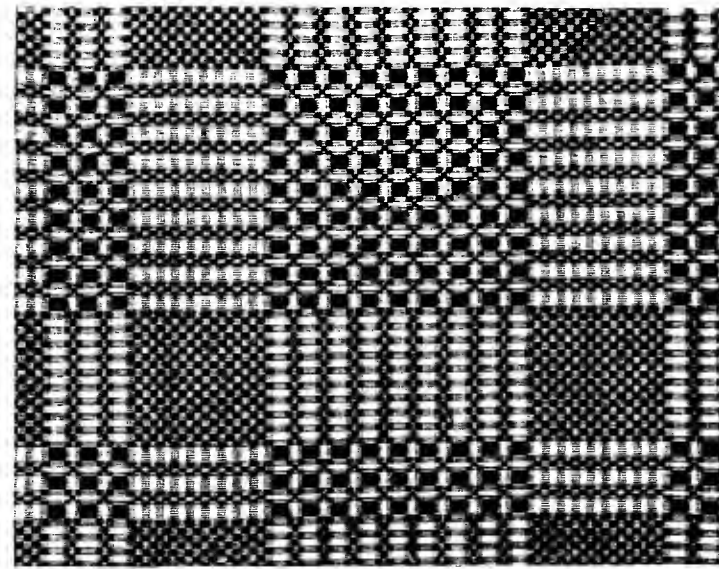


Fig. 143—Braddock's Defeat. Original Pattern

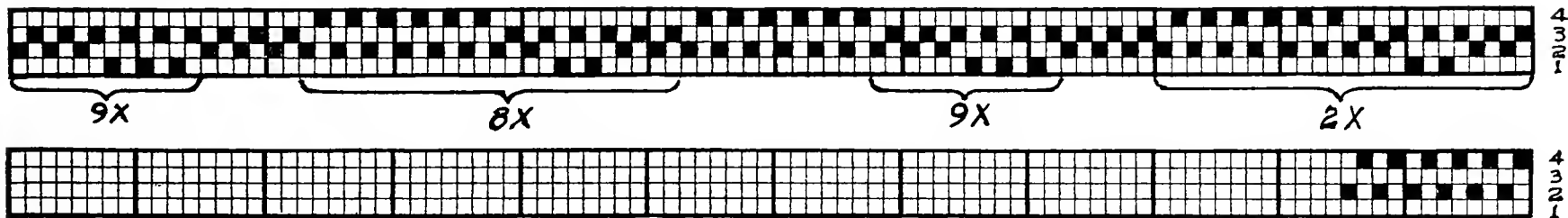


Fig. 144—Braddock's Defeat. Draft of Pattern

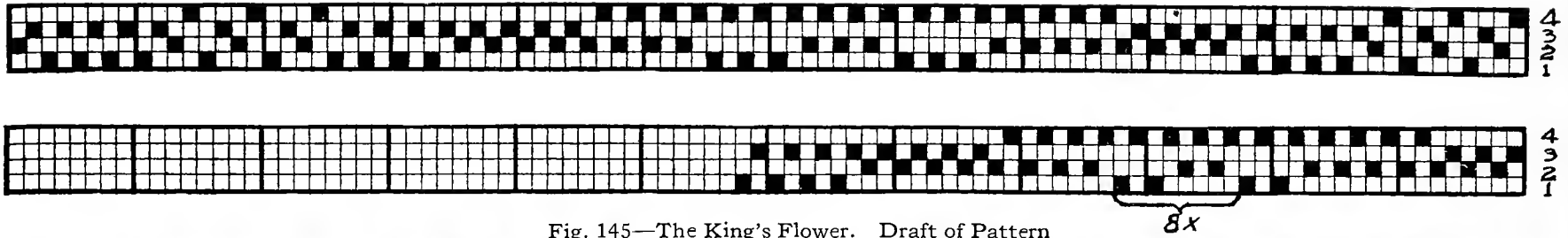


Fig. 145—The King's Flower. Draft of Pattern

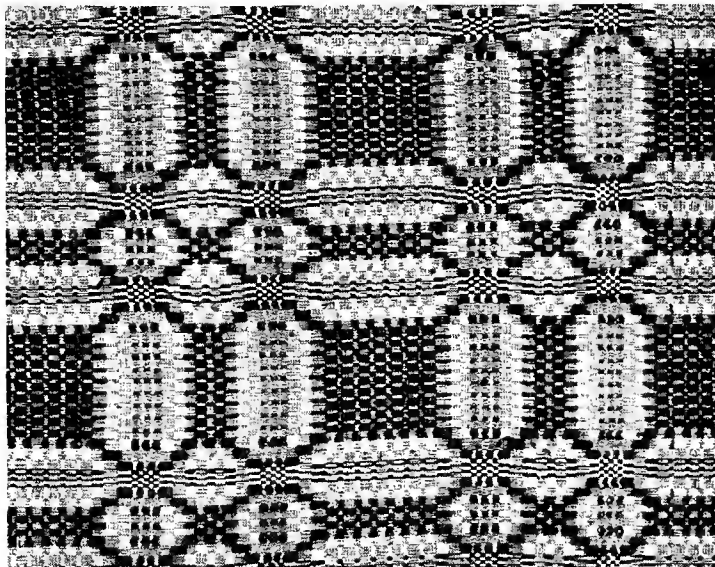


Fig. 146—The King's Flower. Original Pattern

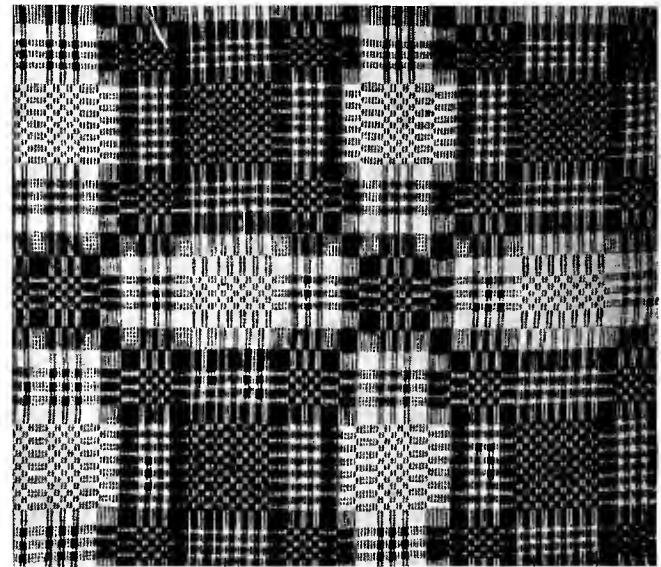


Fig. 147—Queen's Delight. Original Pattern

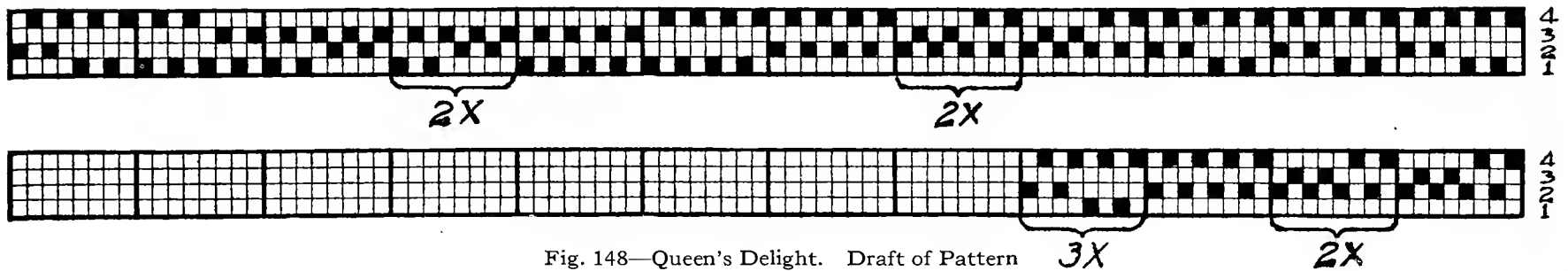


Fig. 148—Queen's Delight. Draft of Pattern

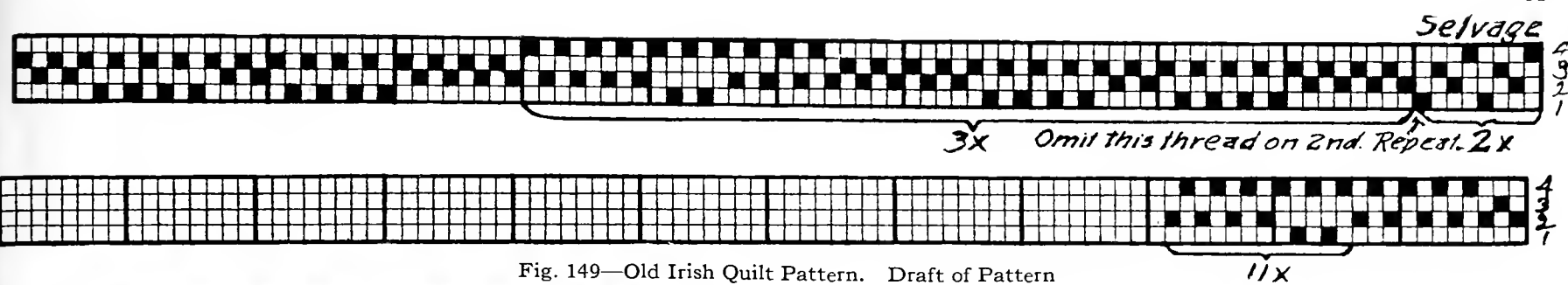


Fig. 149—Old Irish Quilt Pattern. Draft of Pattern

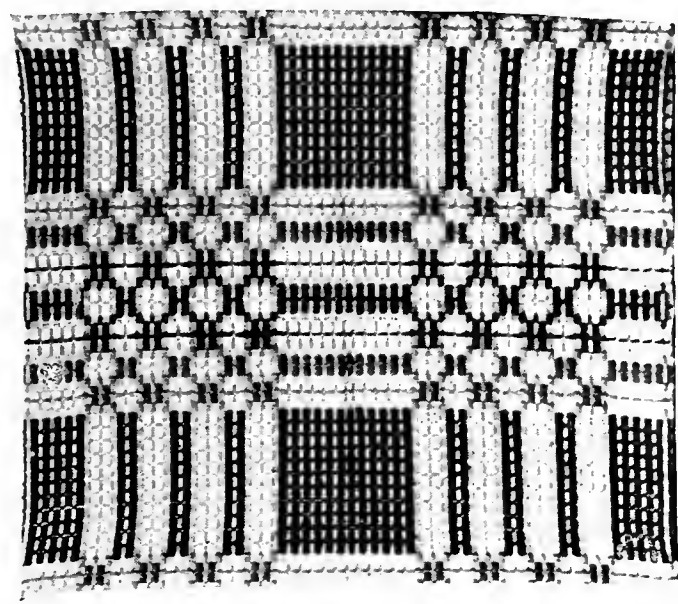


Fig. 150—Old Irish Quilt Pattern. Original Pattern

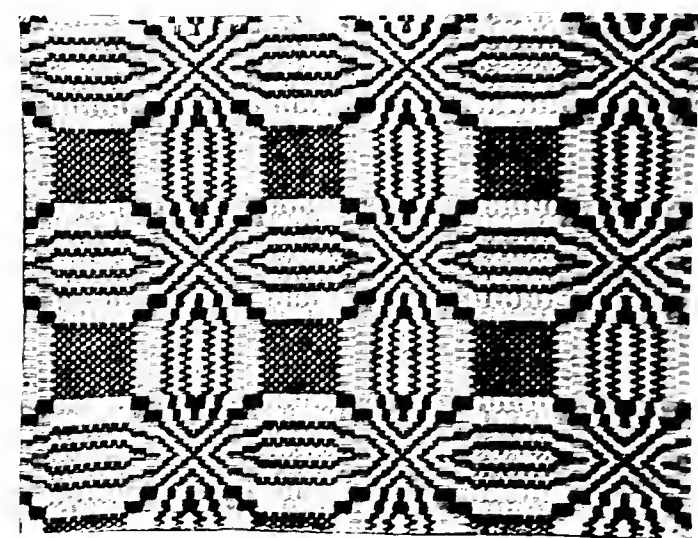


Fig. 151—The Cross. Original Pattern

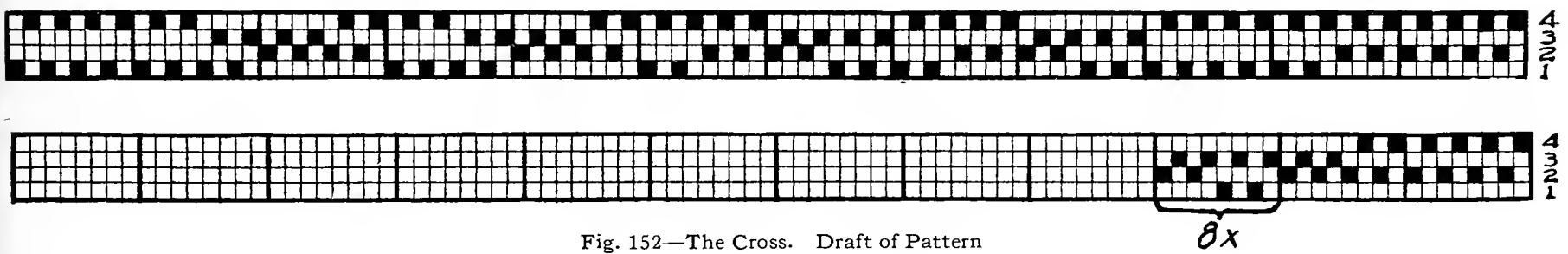


Fig. 152—The Cross. Draft of Pattern

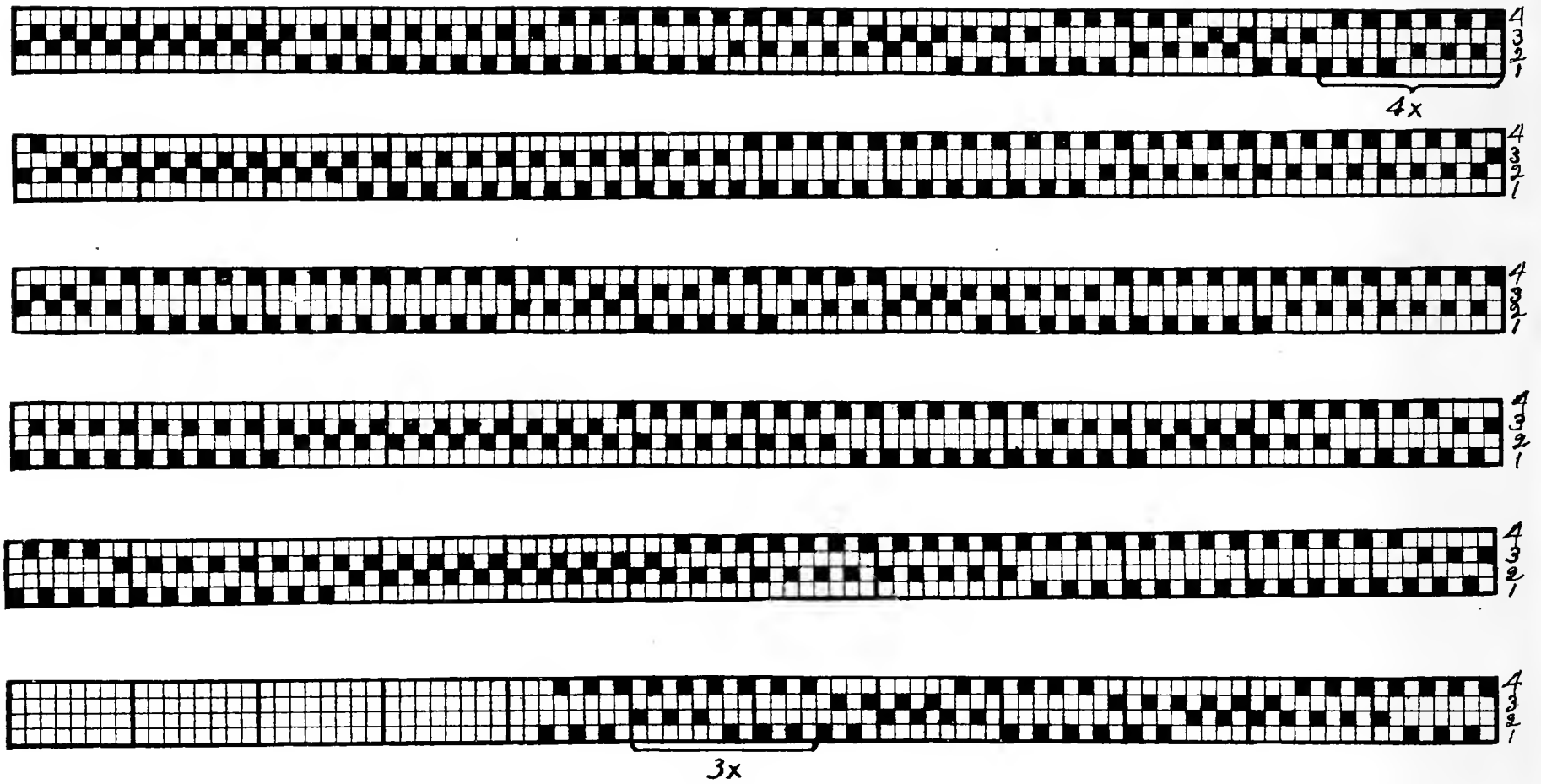


Fig. 153—Double Bow Knot. Draft of Pattern

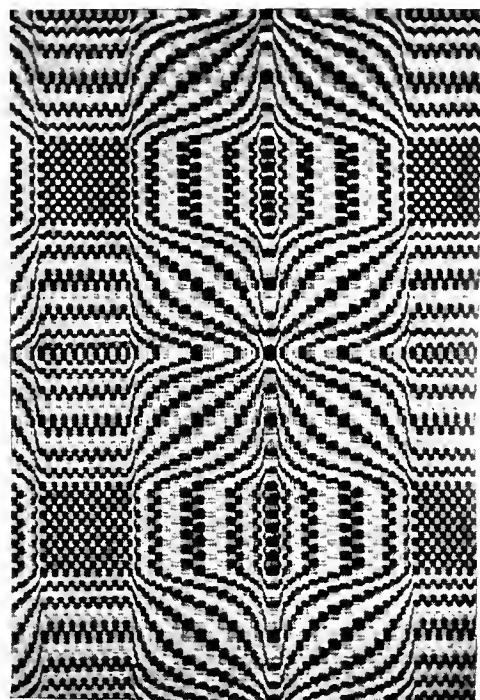


Fig. 154—Double Bow Knot. Original Pattern

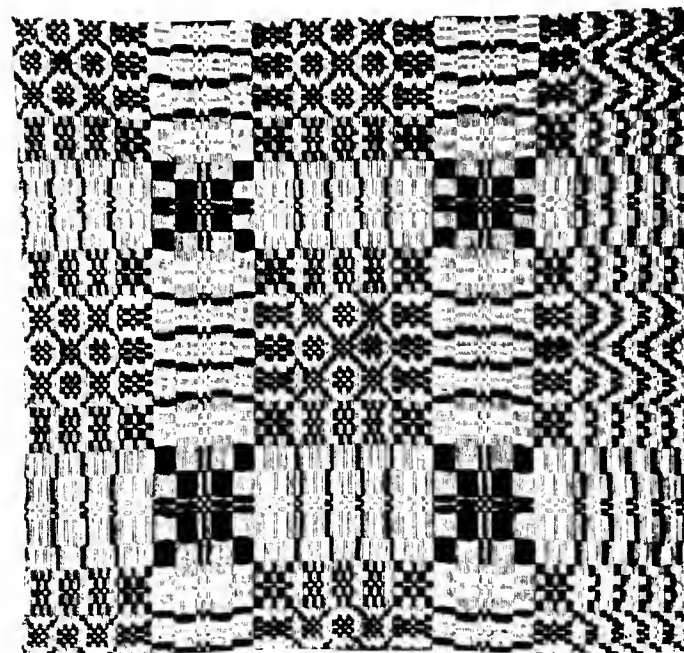


Fig. 155—Four Wheels. Original Pattern

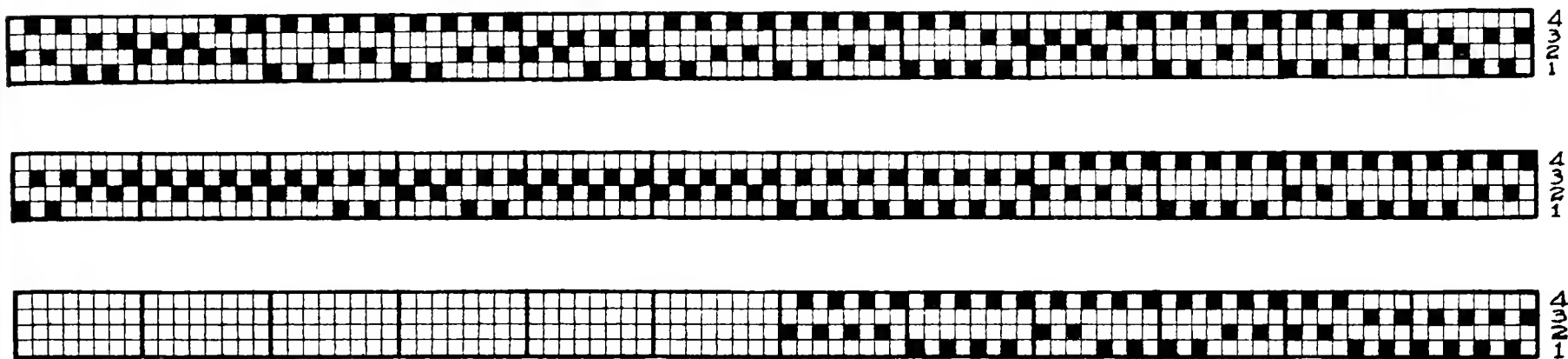


Fig. 156—Four Wheels. Draft of Pattern

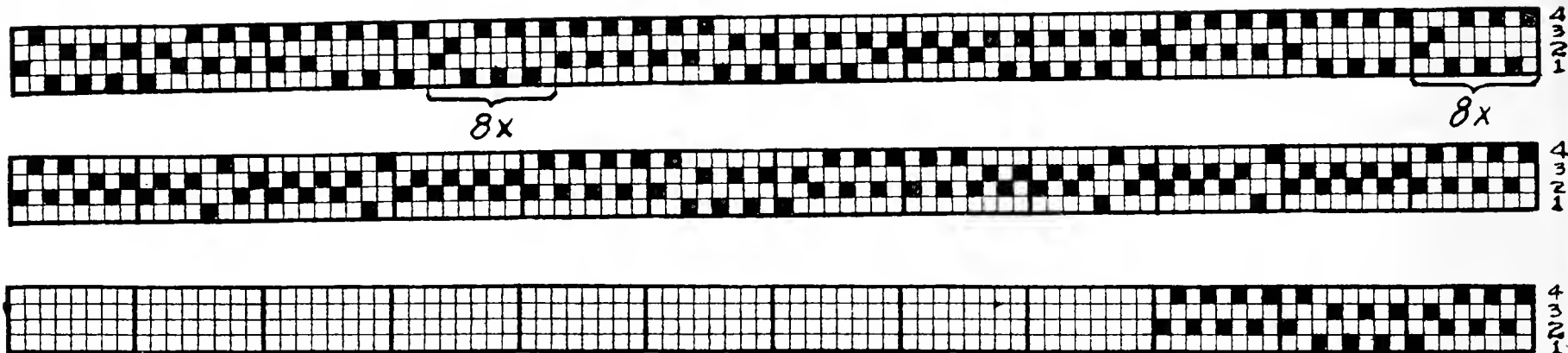


Fig. 157.—Virginian Snow Ball. Draft of Pattern

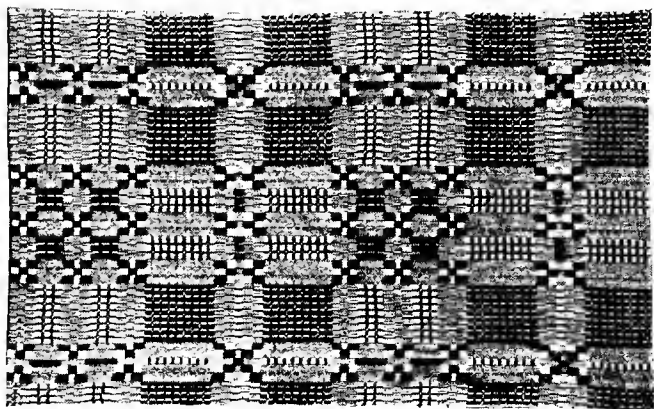


Fig. 158—Virginian Snow Ball. Original Pattern

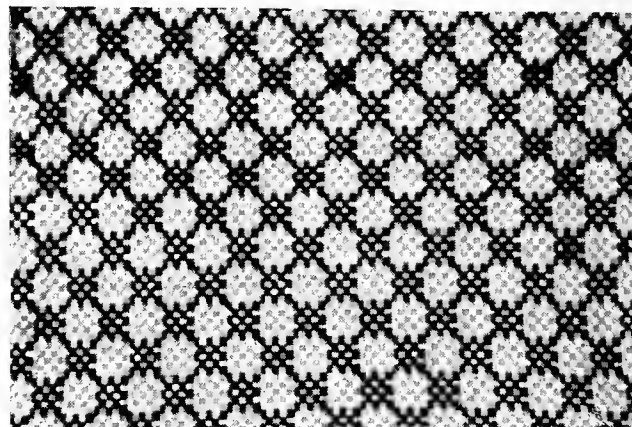


Fig. 159—Dog Tracks. Original Pattern



Fig. 160—Dog Tracks. Draft of Pattern

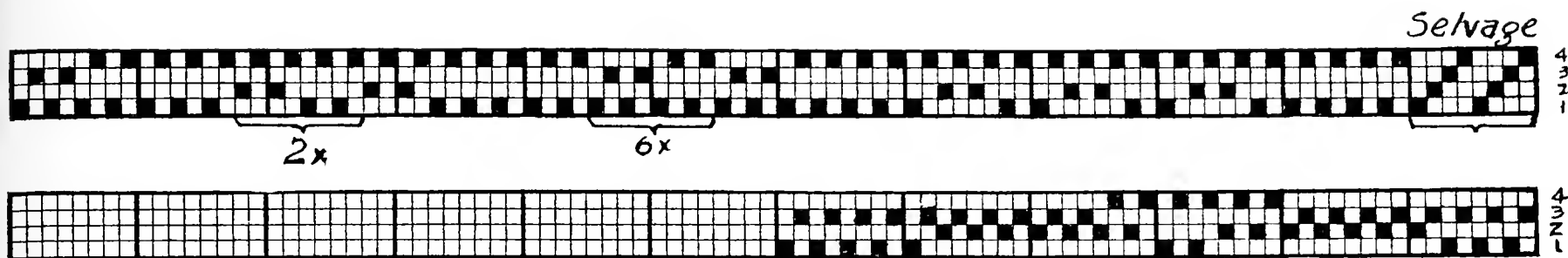


Fig. 161—The Platform. Draft of Pattern

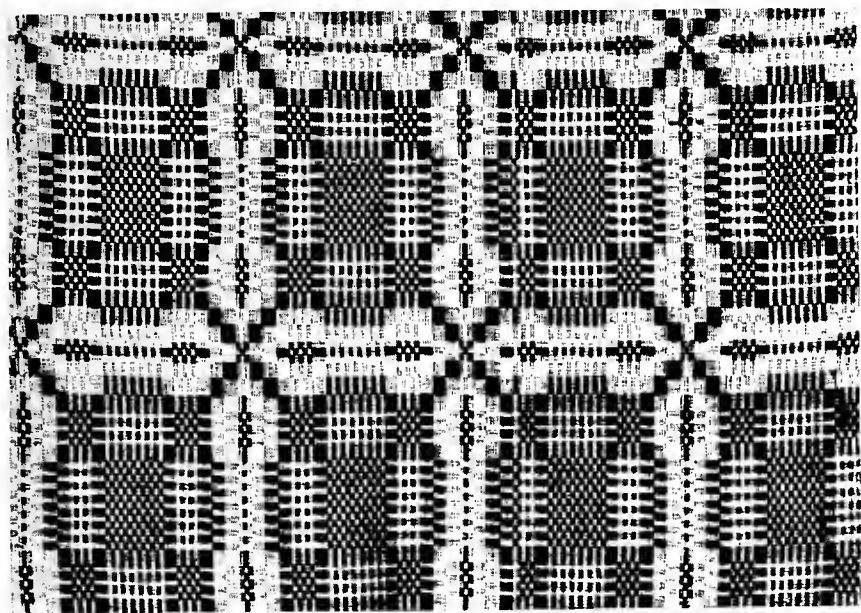


Fig. 162—The Platform. Original Pattern

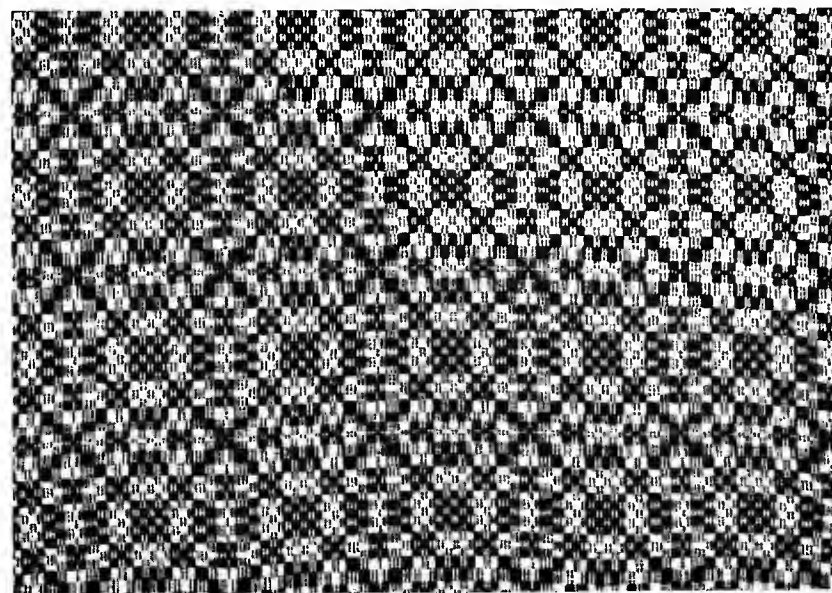


Fig. 163—Guess Me. Original Pattern

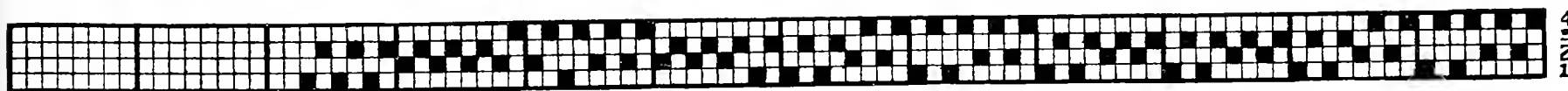


Fig. 164—Guess Me. Draft of Pattern

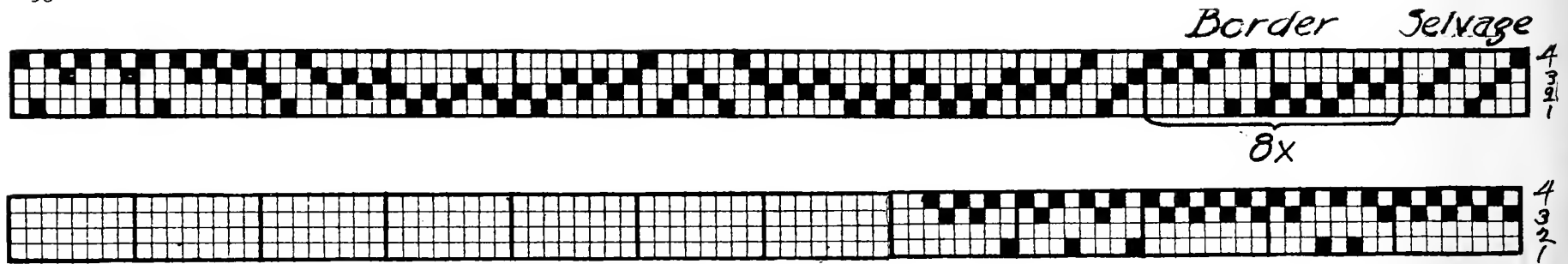


Fig. 165—Wind Flower. Draft of Pattern

order easily to read the various changes and make the “tie-up” stand out.

It is better to figure out the “tie-up” for the pattern first. The plain weave “tie-up” cannot be the same as any one of the pattern combinations.

It is only possible to have six combinations in all. This makes the plain “tie-up” very apparent, as it must be either 1 and 2, 3 and 4, or 1 and 3, 2 and 4. Very rarely does it appear in any other combination.

There are other ways for the amateur weaver to determine this, but for the present the one given is sufficient.

With the knowledge previously gained the “tie-

up” for each of the following drafts may easily be determined.

Wind Flower

The “Wind Flower” is a good example of a counterpane in which two drafts are used; one to be followed in the threading, and the other to be followed in using the treadles.

Figure 165 shows exactly the way the loom should be threaded to produce the pattern shown in Fig. 167. After the threading is completed there is no further use for Fig. 165. The lambs and treadles are tied the same as in previous patterns:

2 and 3 to the first treadle.

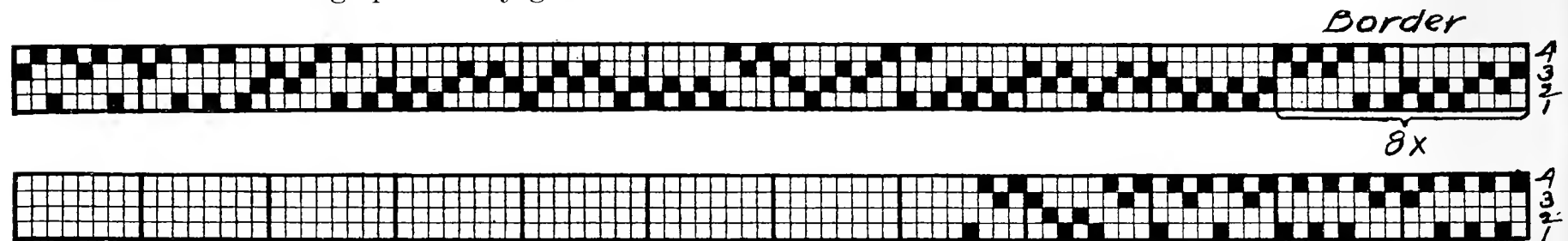


Fig. 166—Wind Flower. Treadle Draft

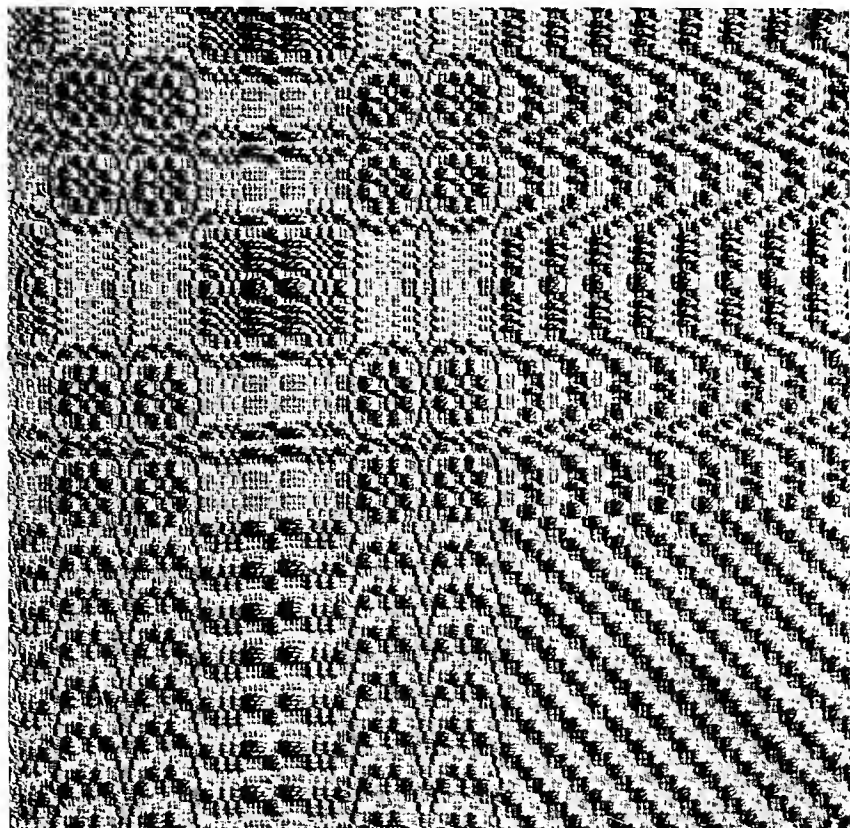


Fig. 167—Original Pattern and Border Woven from The Wind Flower Pattern

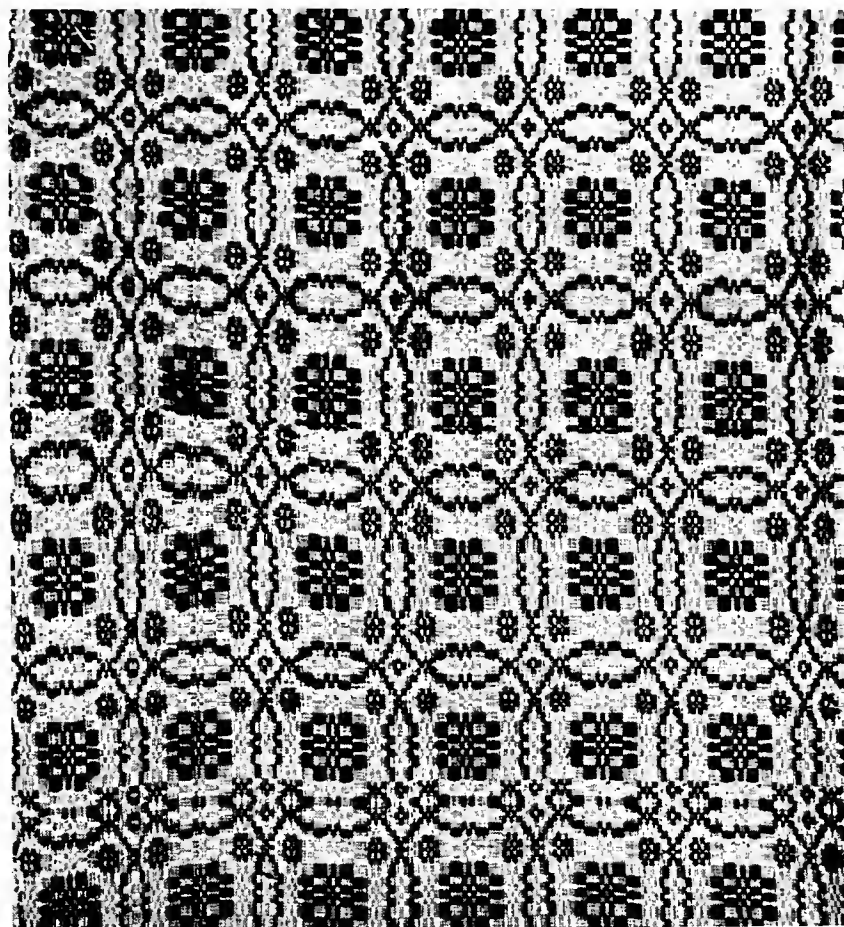


Fig. 168—The Whig Rose. Original Pattern

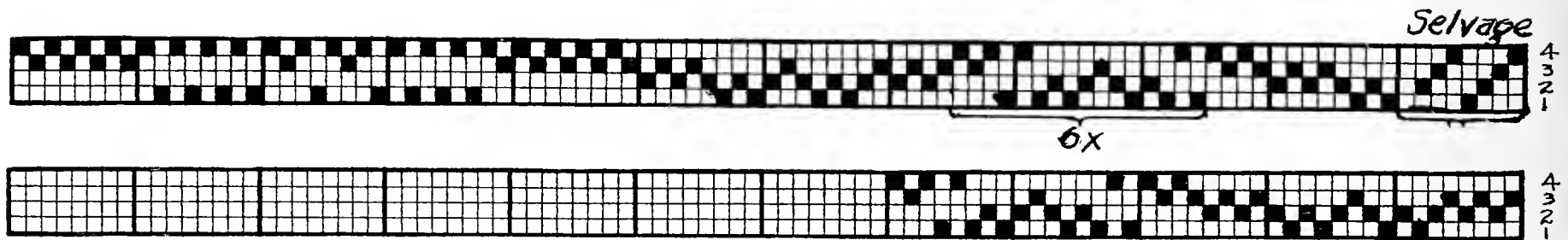


Fig. 169—The Whig Rose. Draft of Pattern

1 and 2 to the second.

1 and 4 to the third.

3 and 4 to the fourth.

For the plain weave, 2 and 4 are tied together, and 1 and 3.

When weaving, Fig. 166 is followed; the weaver pressing down such treadles as will draw down the threads indicated in the treadling draft. To determine the number of times each treadle should be pressed down the draft may be divided in groups of threads as suggested in Fig. 76.

The Whig Rose

Figure 168 shows another pattern woven by using two drafts, one for threading and one for

treadling. Fig. 169 shows the threading draft for the Whig Rose, while 165 shows the treadling draft for the same. The pattern treadles are tied 1 and 2 to the first treadle, 2 and 3 to the second, 3 and 4 to the third, 1 and 4 to the fourth.

The plain weave is done by tying 1 and 3 to the right middle treadle, and 2 and 4 to the left middle treadle.

After the threading has been completed there is no further use for Fig. 169. When weaving, follow Fig. 170, remembering that each dark square represents one woof thread.

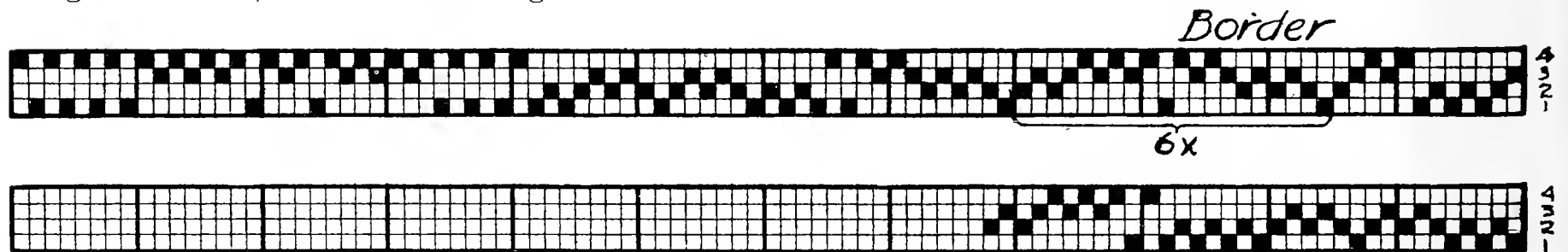


Fig. 170—The Whig Rose. Draft of Pattern

CHAPTER IV

Danish and Norwegian Weaving

Ways of Expressing Danish Patterns

It has been stated already that no attempt has been made to make this manual technical. The plan is to keep every pattern simple and to tell of its execution in as simple a way as possible.

The Danes, Swedes, and Norwegians have carried weaving on the foot-power loom to a high degree of *efficiency*. The work is carried on to a very great extent in the homes. This is largely due to the fact that the governments of these countries encourage weaving as a home industry. Each of these countries has its own way of writing and reading drafts. It is the purpose of this manual to give to amateur weavers an explanation of the way each of the three nationalities writes and interprets its drafts.

Reading a Draft

Figure 171 shows a four-harness pattern woven by using three treadles. The lower heddle sticks are tied one to each lamb.

The treadles are tied as indicated by the stars placed on the horizontal lines just to the right of the threading. The tie-up is interpreted as follows:

Lambs 2 and 4 tie to the first treadle.

Lambs 1 and 3 tie to the second treadle.

Lambs 1 and 2 tie to the third treadle.

The order in which the treadles are pressed down is indicated by the stars on the vertical lines just to the right of the woven pattern. Treadle No. 3 is pressed down first, then treadle No. 2, then back to No. 3, next No. 1, and then back to No. 3, etc.

Figure 172 shows the draft and a woven sample for a two-harness loom. Each horizontal line above the woven pattern stands for a pair of heddle sticks (harness). Each vertical line stands for a treadle. This draft is threaded in the following way:

The first thread passes through the eye of the heddle on the first pair of heddle sticks. The second thread passes through the eye of the heddle on the second pair of heddle sticks. Each time a heddle is threaded, it is pushed along. The third thread passes through the eye of the heddle on the third heddle stick and is pushed along. The fourth thread passes through the eye of the first heddle on the fourth heddle stick and is pushed along. The fifth thread goes back to the first heddle stick

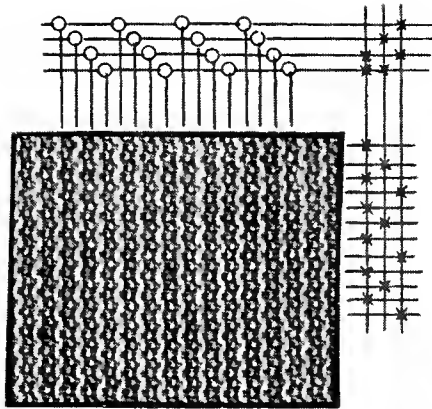


Fig. 171

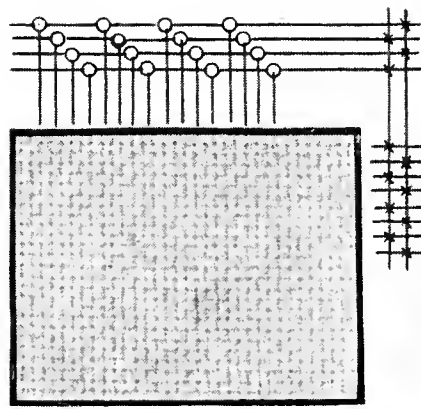


Fig. 172

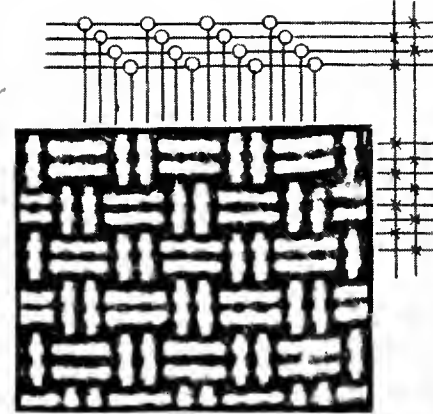


Fig. 173

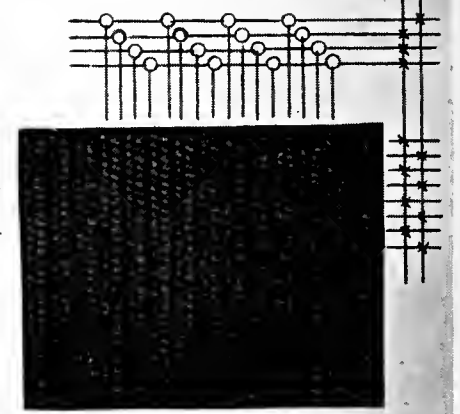


Fig. 174

and is threaded through the eye of the second heddle and is pushed along. The threading continues the same as the first four threads, the order being 1, 2, 3, 4. This is continued until the desired number of threads has been threaded.

It will be observed that only two treadles are used while there are four harnesses for plain weaving. The beginner might ask why use four harnesses when two might answer the purpose. If any great number of threads is to be used in plain weaving, it is better to use four harnesses instead of two, threading as above described.

Tying the Treadle

It will be observed that the lower heddle sticks 2 and 4 are tied to the right treadle, and 1 and 3 to

the left treadle. This is indicated by the stars placed on the vertical lines to the right of the threading draft. With this tie-up, each time a treadle is pressed down, one-half the threads are drawn down. This practically does what two harnesses would do. By using four sets the threads are not crowded so closely together. The stars placed on the vertical lines to the right of the woven sample indicate the order in which the treadles are to be pressed down.

Fig. 173 shows a somewhat checked material. To produce this pattern the warp is made up of blue and white threads. The threading is done the same as in Fig. 172, but first two blue and then two white threads are threaded until the entire number

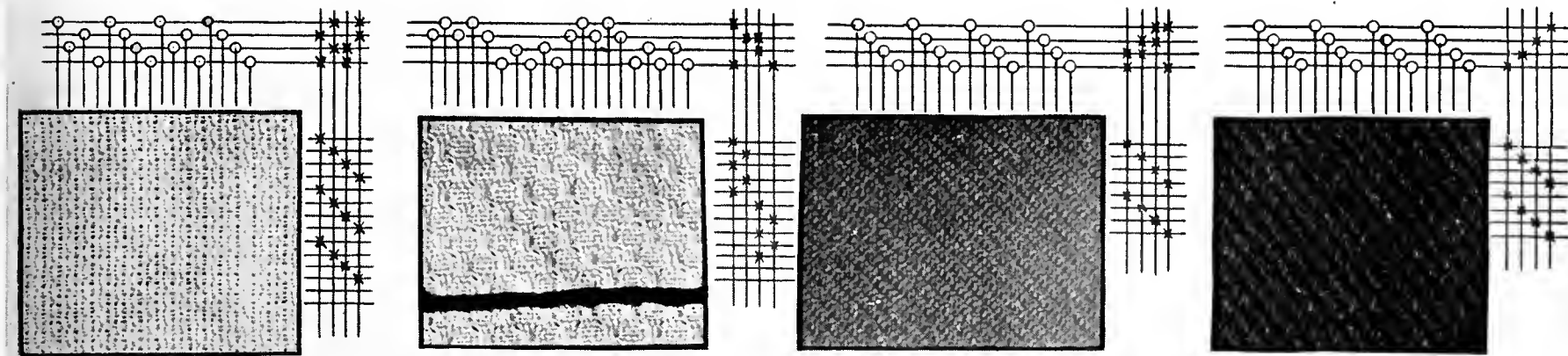


Fig. 175

Fig. 176

Fig. 177

Fig. 178

of threads has been used. When weaving, two blue threads are used and then two white. This necessitates the use of two shuttles. It is also understood that when preparing the warp chain, the spools of warp are so placed on the spool rack that two blue and two white threads are reeled or warped at one time. The stars marked on the vertical lines indicate that first one treadle and then the other is to be pressed down.

Fig. 174 shows another four-harness, but practically only two-harness pattern. The threading is done the same as in the two already described. Harnesses 1, 2 and 3 are tied to the left treadle, and harness 4 to the right treadle. This is indicated by the stars placed on the vertical lines to the right of the threading draft.

The stars on the vertical lines to the right of the woven pattern indicate the order in which the treadles are pressed down.

Figure 175 shows a four-harness pattern, a little more irregular in its threading. The greatest care must be exercised when threading.

In tying up this pattern the lambs are tied one to each lower heddle stick. The stars on the vertical lines to the right of the threading indicate the order in which the treadles are tied to the lambs. Treadle No. 1 is tied to the 3rd and 4th lambs. Treadle No. 2 is tied to the 1st and 2nd lambs. Treadle No. 3 is tied to the 2nd and 4th lambs. Treadle No. 4 is tied to the 1st and 3rd lambs.

The stars on the vertical lines, to the right of the woven pattern, indicate the order in which the

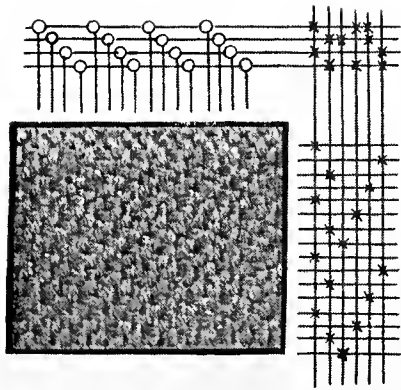


Fig. 179

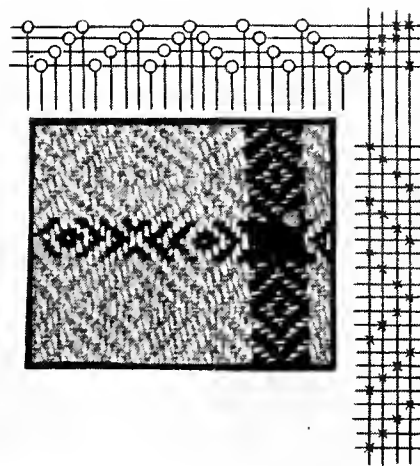


Fig. 180

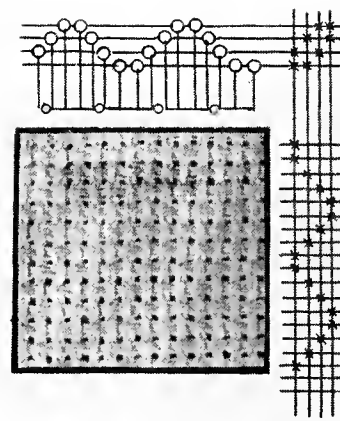


Fig. 181

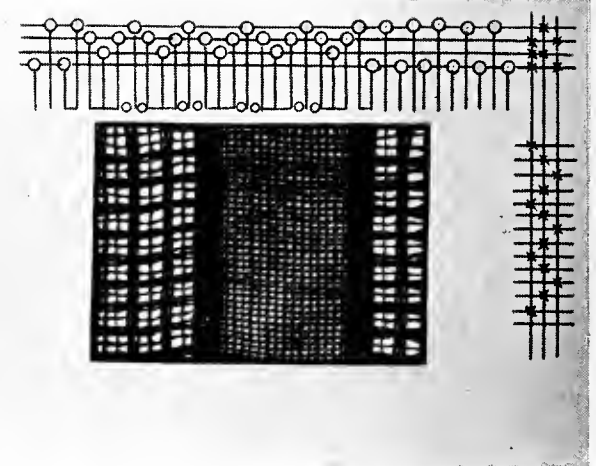


Fig. 182

treadles are to be pressed down. The order is first treadle 4, then 3, 2 and 1. Then back again to 4, 3, 2, 1. This order is continued throughout the entire weaving.

Figure 176 shows a most interesting weave for towels. The warp and woof should be of linen. The threading is done as shown in the draft. Lambs and treadles are tied as shown by stars to the right of the threading draft. The order of treadling is shown by stars on vertical lines to the right of woven sample.

Figure 177 shows a serge. The warp and woof should be of wool. Threading and tie-up are as indicated in the draft.

Fig. 178 shows another serge weave.

Figure 179 shows a pattern woven on a six treadle loom. The method of handling more than four harnesses will be treated a little later. It is a very interesting weave which may be used for winter coats. The warp and woof are of wool. Two threads are drawn through each dent of the reed. Note the irregular way in which the treadles are pressed down.

Figure 180 shows an interesting weave to be used in towels. The dark, vertical stripe shows a number of colored threads reeled in the warp, while the horizontal dark stripe indicates that the same color is used as woof.

This pattern is commonly known as the "Goose Eye." The threading and treadling are done as indicated. Two threads are drawn through each dent.

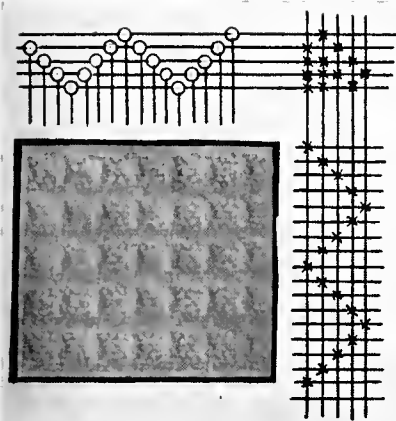


Fig. 183

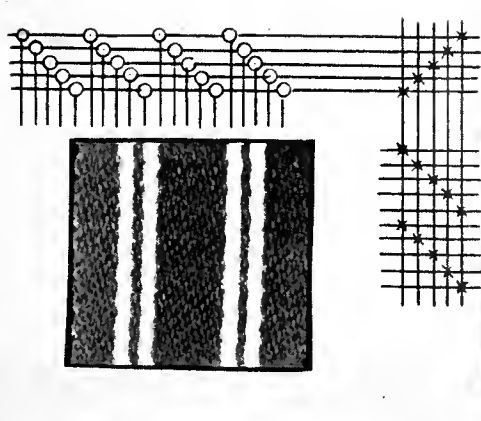


Fig. 184

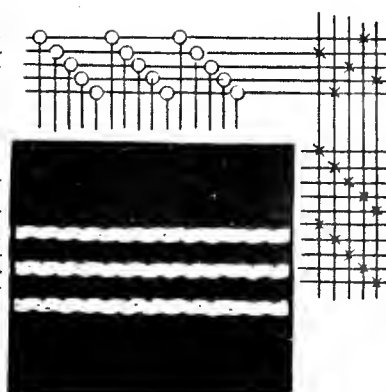


Fig. 185

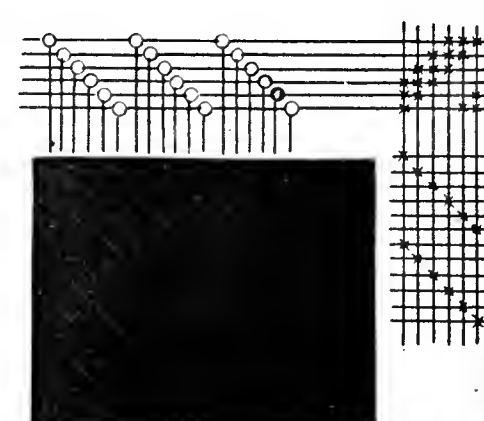


Fig. 186

Figure 181 shows a canvas weave. The threading is done the same as in previous patterns. The little circle placed below and between the groups of threads only indicates that a dent in the reed is to be omitted and has no reference to the threading of the pattern.

It will be observed that the threads are in groups, four in each. Each group of four threads is drawn through every other dent of the reed. In other words, every other dent of the reed is left vacant. The threads on heddle sticks 1 and 2 make one group and the threads on heddle sticks 3 and 4 make another group. This is clearly shown in the draft. When weaving, the first and fourth wool threads are to be double.

Fig. 182 shows a very interesting curtain ma-

terial woven by using four harnesses and three treadles.

The plain stripe is shown in the first part of the threading draft. This number of threads may be increased so as to make any width desired. The closely woven bands at the edges of the plain stripe are obtained by drawing two threads through each dent.

The open work is produced by drawing the three threads, held together at the base, through a single dent. The small circles between the groups indicate a dent to be omitted. The tie-up and treadling are done as indicated in the draft.

In Figs. 183, 184, 185, and 186 are given examples of five and six harness patterns. While these drafts are threaded and tied up the same as

other patterns, the method of hanging the harnesses is somewhat different and will be taken up in detail a little later.

Norwegian Patterns

The three patterns which follow show that the Danish and Norwegian ways of writing patterns are very much the same.

Figure 187 shows a very interesting pattern and draft which may be produced on a four-harness loom using eight treadles. In reeling the warp, eight threads of one color are used (say blue) and then eight threads of white. Two threads are drawn through the eye of each heddle and also through each dent of the reed. The woof thread is also wound double on the bobbins so that each time the shuttle passes through the shed two threads are carried at the same time.

The horizontal parallel lines represent the harnesses, which are the same as heddle sticks. The vertical parallel lines represent the treadles. The stars indicate the way the treadles are tied to the lams. The little dashes on the vertical lines indicate the order in which the treadles are pressed down. This order of treading is continued until the desired amount of fabric is woven.

Figure 188 shows a pattern in which the reeling is done by running three blue threads and one white thread on the beam. The entire warp is made

Fig. 187

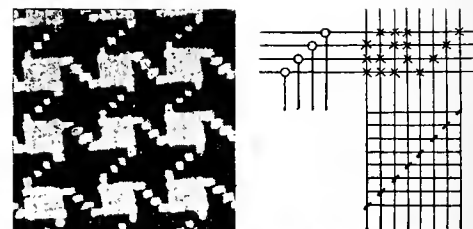


Fig. 188

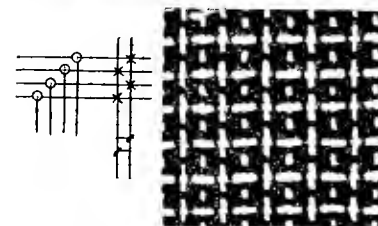
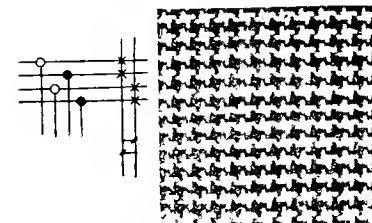


Fig. 189



up in this way, three blue and one white. Each thread passes through the eye of a heddle, and only one thread to each dent of the reed. When weaving, three blue woof threads are woven and then one white.

In warping for the pattern shown in Fig. 189, two blue and two white threads are warped at the same time. The threading is done by threading singly two blue and then two white, as indicated in the draft. Two threads are drawn through each dent of the reed.

CHAPTER V

Swedish Weaving

Swedish Way of Writing a Draft

In many respects the Swedish way of writing a draft is more simple than any of the other ways described.

The patterns which follow are all written in the Swedish manner and are interpreted in the following way:

In Fig. 191 is shown a two-harness pattern. The threading indicates that two threads are drawn through each eye of the heddles; two through the eye of the first heddle on the back heddle sticks, and then two through the eye of the first heddle on the first or front heddle sticks.

It may also be done by threading only one thread through each eye but using two heddles on the same sticks. Two threads may be drawn through each dent of the reed.

Figure 193 shows what may be called either a two-treadle or four-treadle draft. If two treadles are used, two lambs tie to each treadle. It must always be remembered that each lamb is tied to a lower heddle stick. Tying to the lambs is the same as tying to the lower heddle sticks.

When the foot presses a treadle it draws down two harnesses.

If four treadles are used, one to each lamb, it is necessary to use both feet in pressing down two treadles at the same time. The treadles marked one and one indicate that these are the first to be pressed down and mean treadles 1 and 3. Two and two indicate the second change and indicate that the second and fourth treadles are pressed down.

Figure 192 shows the draft for a four-harness loom. The space between each pair of horizontal parallel lines stands for a pair of heddle sticks.

Each space between the vertical parallel line represents a treadle. The little dots within the small squares indicate the order in which the treadles are to be tied to the lambs.

The figures just below the dots indicate the order in which the treadles are pressed down.

Figure 192 is threaded by passing a thread through the eye of the heddle on the back or fourth heddle sticks. The second thread passes through the eye of the heddle on the third heddle sticks, the third thread passes through the eye of the heddle on

the second, and the fourth thread passes through the eye of the first heddle on the first or front heddle sticks.

The entire draft is threaded by following this order:

The lambs are tied one to each lower heddle stick. The pattern indicates according to the little dots that the fourth lamb is tied to the first treadle, the second lamb is tied to the second treadle, the third lamb is tied to the third treadle, and the first lamb is tied to the fourth treadle.

The figures just below the dots indicate that the treadles are pressed down in the order of first 1, then 2, 3, and 4. This order of treading is kept up until the desired amount of material is woven.

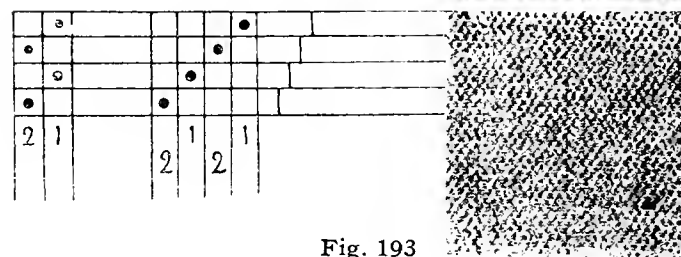
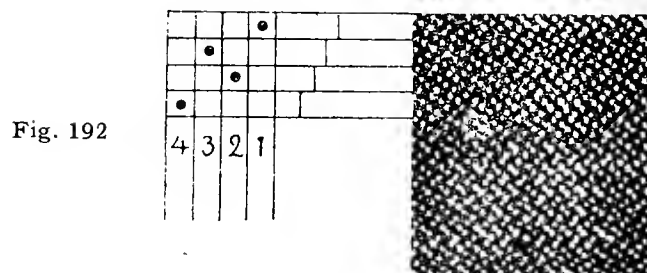
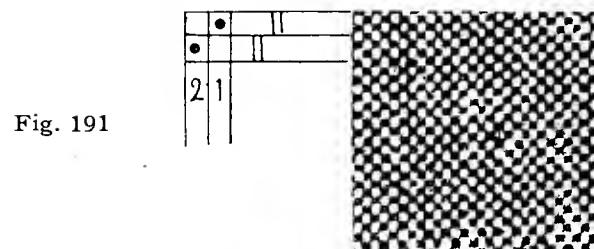
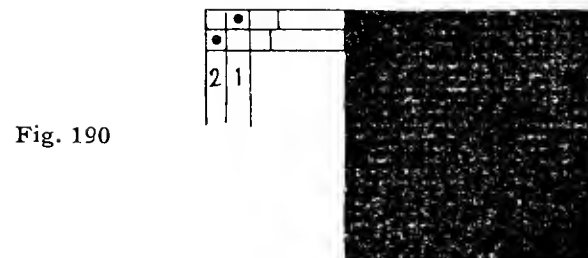
In Fig. 194 is shown the same threading, but a different order of tying.

Lambs 1 and 2 are tied to the first treadle. Lambs 1 and 3 are tied to the second treadle. Lambs 1 and 2 are tied to the third treadle. Lambs 2 and 4 are tied to the fourth treadle.

The order of pressing the treadles is shown by the figures.

In Fig. 196 the threading is the same as in the two previous patterns. The lambs are tied as follows:

- 1, 3 and 4 to the first treadle.
- 2 and 3 to the second treadle.
- 1, 2 and 3 to the third treadle.
- 2 and 4 to the fourth treadle.



- 1 to the fifth treadle.
- 2 to the sixth treadle.

While this pattern requires six treadles, there will be no difficulty in understanding the tie-up.

Fig. 194

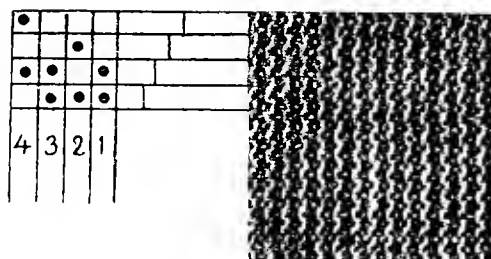


Fig. 195

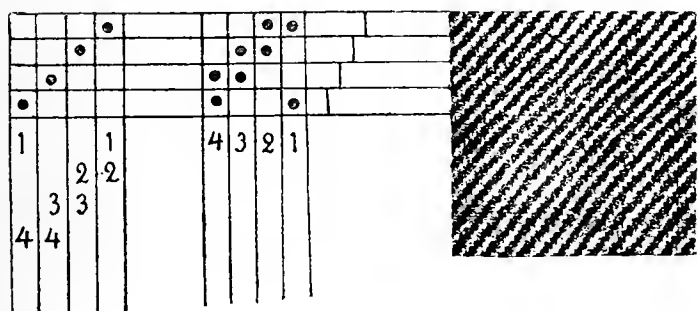
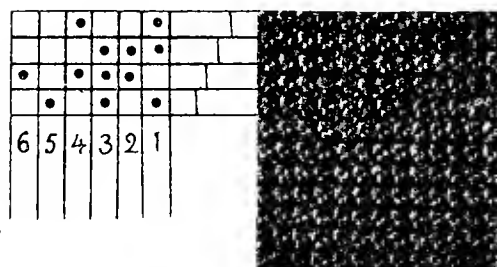


Fig. 196

Figure 196 shows the same threading and two ways of "tie-up." The first shows each lower heddle stick tied to a treadle. In such case treadles 1 and 4 are pressed down the first time, indicated by the two ones. The next time treadles 1 and 2 are pressed down at the same time, indicated by the two twos. The third time treadles 2 and 3 are pressed down, indicated by the two threes. The fourth time treadles 3 and 4 are pressed down, indicated by the two fours. After following this order once it is gone right over again and continued until the desired amount of material is woven.

The other tying gives exactly the same result because of the fact that two lambs are tied to one treadle. This latter plan is better and makes it possible to accomplish much greater results in the amount of fabrics woven.

In the next four patterns, 197 to 200 inclusive, the threading is the same as in previous patterns. The treadling is done by following the order of numbering.

In Fig. 199 the number 5 means that the third treadle is to be pressed down, and number 6 indicates the second treadle pressed down.

In Fig. 201 the threading is done the same as in the two-harness loom draft shown in Fig. 191.

Irregular Threading

In Fig. 202 is shown the first irregular threading. The first thread passes through the first heddle on the fourth heddle stick, the second thread passes through the first heddle on the third heddle stick, the third thread goes back to the second heddle on the fourth heddle stick, the fourth thread to the second heddle on the third heddle stick, the fifth thread through the first heddle on the second heddle stick, the sixth thread through the first heddle on the first heddle stick, the seventh thread through the second heddle on the second heddle stick, and the eighth thread through the second heddle on the first heddle stick.

In Fig. 203 is shown another irregular threading; first between the 3rd and 4th heddles and then between the 1st and 2nd. Observe the grouping of the treadling.

The lambs are tied as indicated by the dots. The treadles are pressed down as indicated by the figures. The first time treadle 1 is pressed down. The next No. 2, the third time No. 1 again, the fourth time No. 2 again. The fifth time No. 1. The next five times are between treadles 3 and 4. The next goes back to the first and second treadles. This order is kept up until the desired amount of material is woven.

Figure 204 shows what is known as the "Honey

Fig. 197

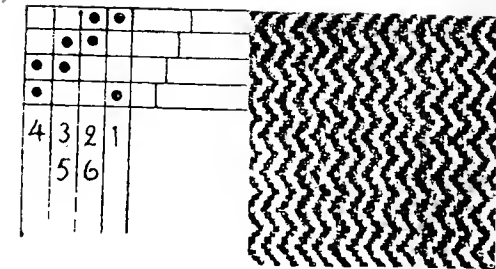


Fig. 198

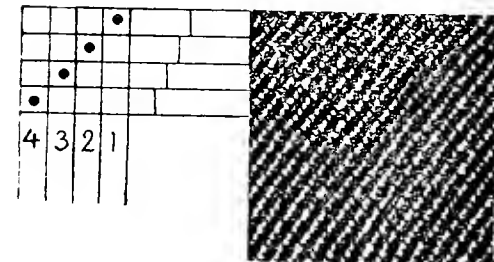


Fig. 199

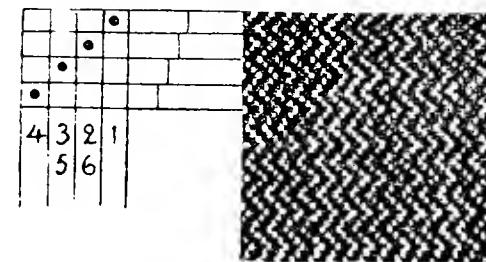


Fig. 200

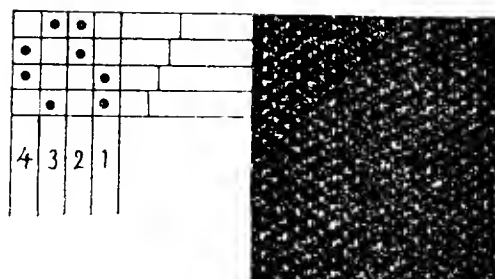


Fig. 201

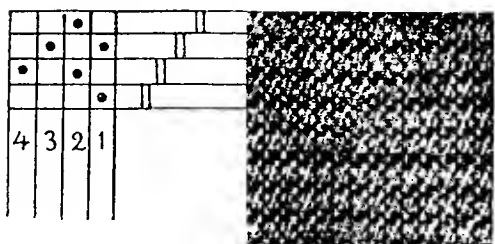
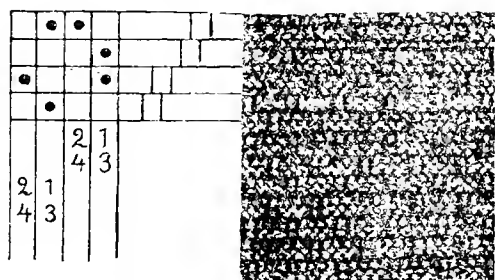


Fig. 202



Comb Weave." There will be no difficulty in understanding the threading. The first fourteen threads are on the third and fourth harnesses. The second fourteen threads are on the first and second harnesses. To produce the effect shown in the finished pattern the entire warp is threaded just as shown in the draft. If a variation is desired the loom may be threaded so six inches will be the same as shown in the finished pattern. A four-inch stripe may be threaded by drawing 28 threads through the heddles on the third and fourth harnesses and then 28 on the first and second. This is continued until the desired width is obtained. The next step is to go back to the fourteen threads. The treadles are tied one to each lamb. In weaving, the first fourteen threads of the woof are woven by pressing down the first and then the second treadles.

The next is to press down treadles one and three at the same time. This is indicated by 1 and 1. The next is to press down treadles two and four at the same time, and is indicated by the figures 2 and 2. The next fourteen threads are woven in by pressing down treadles three and four as indicated by the figures placed in the vertical spaces. This order of treadling is kept up until the material is woven.

Figure 206 shows a threading which is the same as that of the Rose Path. By following the order

icated by the number 8; back to number 1 for the third time, indicated by the number 9.

The second change consists of the reverse order of treadling.

Figure 209 shows a four-harness pattern which may be accomplished by using four treadles or eight treadles. Observe the difference in the tie-up. If four treadles are used they are pressed down in their regular order, 1 to 4.

The next time treadles 1, 2, and 3 are all pressed down at the same time. This is indicated by the three ones.

Treadles 1, 2, and 4 are next pressed down, indicated by three twos.

The next time treadles 1, 3 and 4 and the next 2, 3 and 4.

If eight treadles are used and tied as indicated the work is more rapidly carried on.

Figure 210 shows a four-harness loom. The pattern is accomplished by tying and treadling as indicated in the draft.

Three-Harness Draft

The amateur weaver by this time has no doubt gained sufficient knowledge of the two and four-harness drafts not only to do the threading successfully but also to "tie-up" for any pattern desired. Occasionally a draft appears which is written in three harnesses, as shown in Fig. 215. When such

Fig. 206

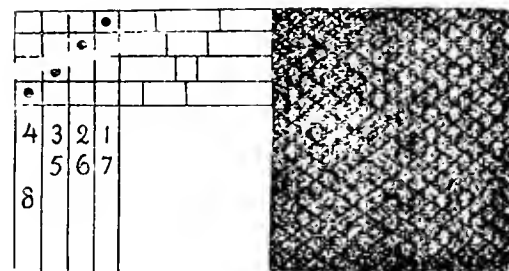


Fig. 207

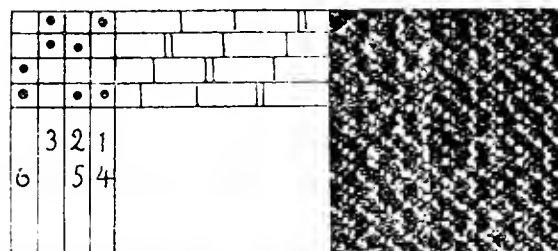
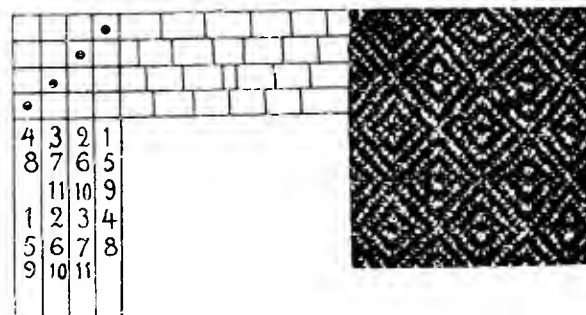


Fig. 208



is the case the upper heddle sticks are tied as shown in Fig. 211. The tying of the treadles is the same as for patterns already described.

Figure 212 shows the way five harnesses are tied.

Figure 213 shows the tie-up for a six-harness

the first heddle on the third heddle stick, the second thread through the eye of the first heddle on the second heddle stick, the third thread goes back to the eye of the second heddle on the third heddle stick.

The next three threads are on heddle sticks 1 and 2.

Figure 217 shows the draft and sample of an interesting curtain material.

The threading is done by following the draft. The threads on harnesses 1 and 2 make the plain weave. The somewhat irregular threading makes the stripe.

When threading the reed draw one thread through each dent for the plain stripe.

Skip one dent and then draw the three threads on heddle sticks 2 and 3 through the same dent.

Skip a dent and then draw the one thread on the first heddle sticks through a dent, skip a dent and draw three, skip, draw one, skip and draw three, etc.

Eight-Harness Pattern

Fig. 219 shows the way the upper heddle sticks for an eight-harness loom are tied. There are always as many lambs used as there are lower heddle sticks. Ordinarily the eight-harness loom works fairly well when tied up as shown in Fig. 219.

The difficulty, if there is any, grows out of the fact that the heddle sticks or harnesses after being

drawn down refuse to return to their original position when the foot releases the treadle. Sometimes weights consisting of rectangular pieces of iron are hung at each end of the heddle sticks. These weights draw the harnesses back in place when raised.

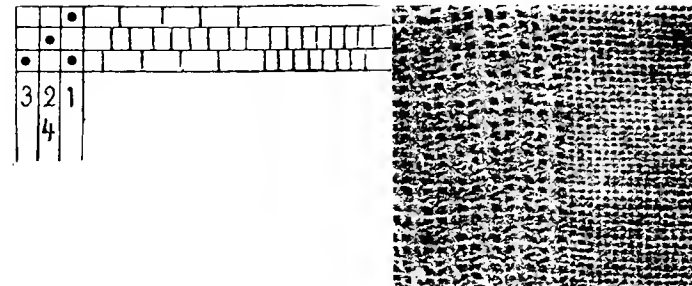
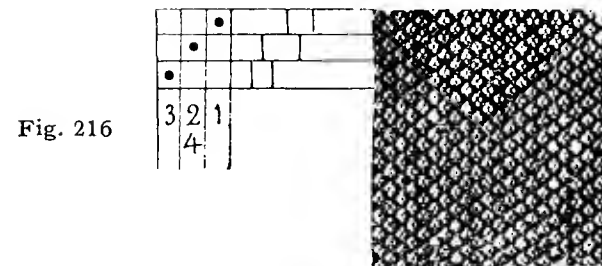
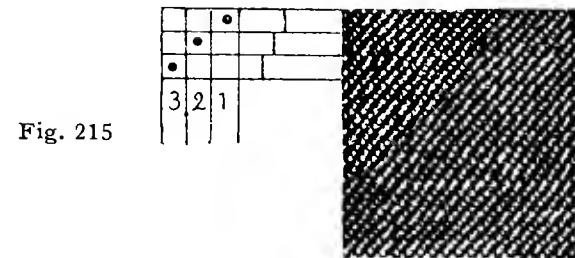


Fig. 217

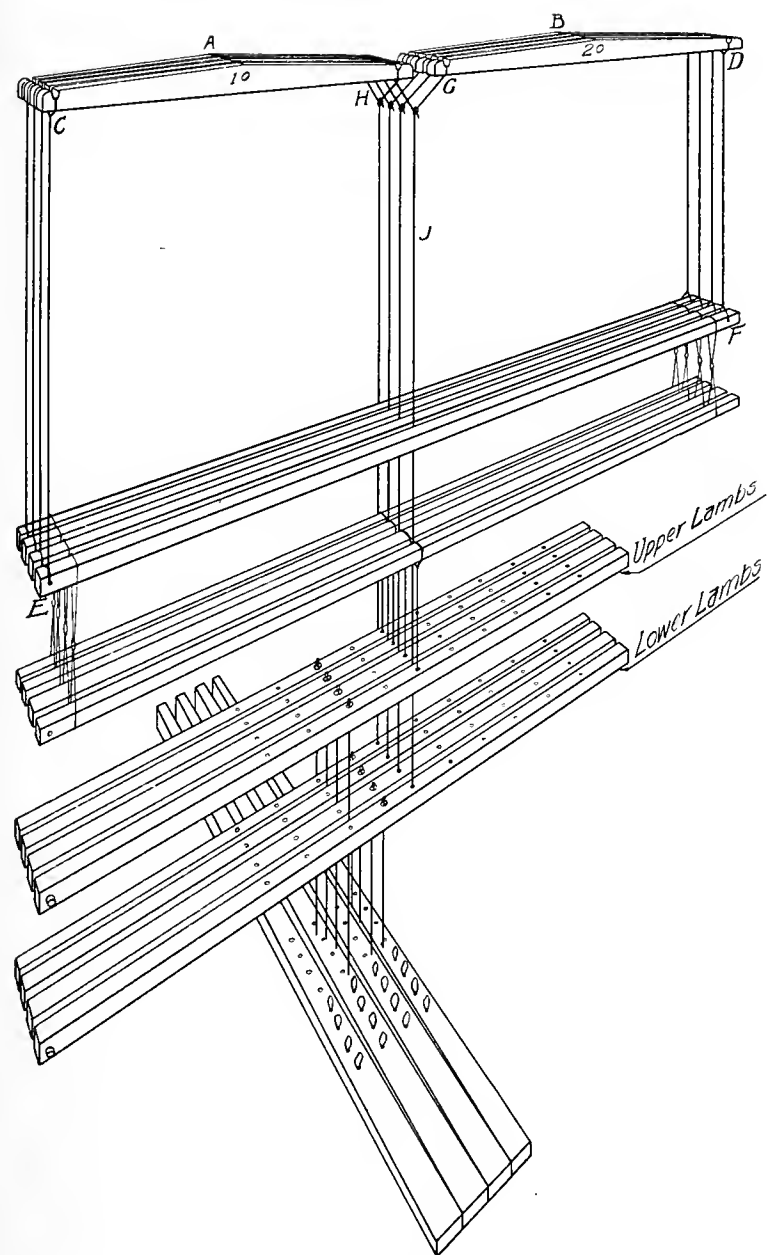


Fig. 220

The various sections are held in place by a half-inch dowel rod as shown at 1 and 2, Fig. 220. The rods are supported by two pieces of 7-8" maple constructed as shown in Fig. 222. This sort of frame work replaces the roller as shown in the finished loom in Fig. 223.

The "Tie-Up"

Returning to Fig. 220, loops of No. 16 blocking cord are tied and hung from each outer end of the levers as shown at C and D in Fig. 220. Two ends of the cord are fastened to each end of the upper heddle sticks, as shown at E and F. The loops and ends are tied just the same as the treadles are tied to the lambs. From the inner ends of the levers H and G, a piece of blocking cord is tied, one end to one, and the other end to the other as shown. From each loop a piece of blocking cord extends to the lower set of lambs by passing between the harness and ties the same as all other connections have been made. Each lower heddle stick ties to an upper lamb the same as in the two and four-harness looms. Loops of blocking cord are now drawn through the holes of the treadles, one in each. The upper lambs are tied to the treadles the same as in every other "tie-up," the cord passing between the lower lambs. The lower lambs are also tied to the treadles by using the loops not used in tying the upper lambs.

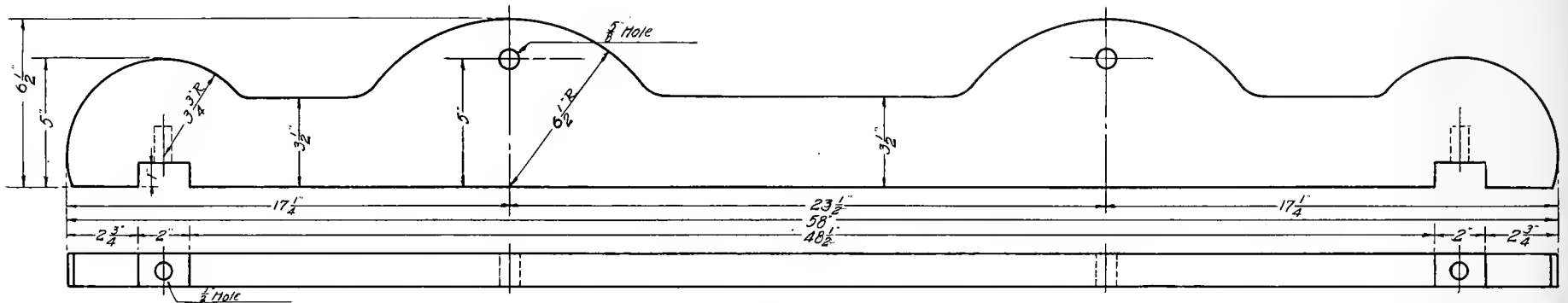


Fig. 222

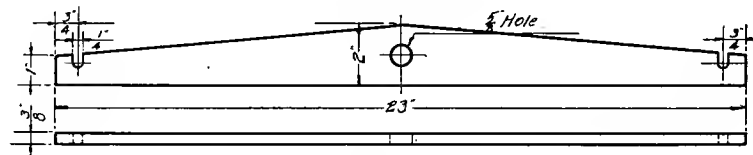


Fig. 221

By tying a loom in this way all harnesses making the pattern are drawn down while the other harnesses are drawn up. No part remains stationary. The weights previously mentioned for drawing the harnesses back in place are no longer necessary. Fig. 220 shows only a four-treadle loom. This is done to avoid complication in the explanation. Any number may be used. This method of tie-up is especially desirable when an odd number of heddle sticks (harnesses) is used. It does away with pulleys and heddle horses, Fig. 223. The fact that each part of the harness must either pull up or down makes a most perfect shed, thus avoiding the skipping of threads, so common in weaving when the shed is not perfect.

Fig. 224 shows a very interesting pattern pro-

duced by either five or six harnesses. The tie-up for each is given in the draft.

The order of treading is indicated by the figures just below the dots indicating the "tie-up."

The material produced may be used in a counterpane as well as in a bathrobe, if so desired.

The warp is run off in two colors in the following order:

112 white	814 white
18 red	18 red
62 white	62 white
18 red	18 red
	112 white

The wool is of both red and white.

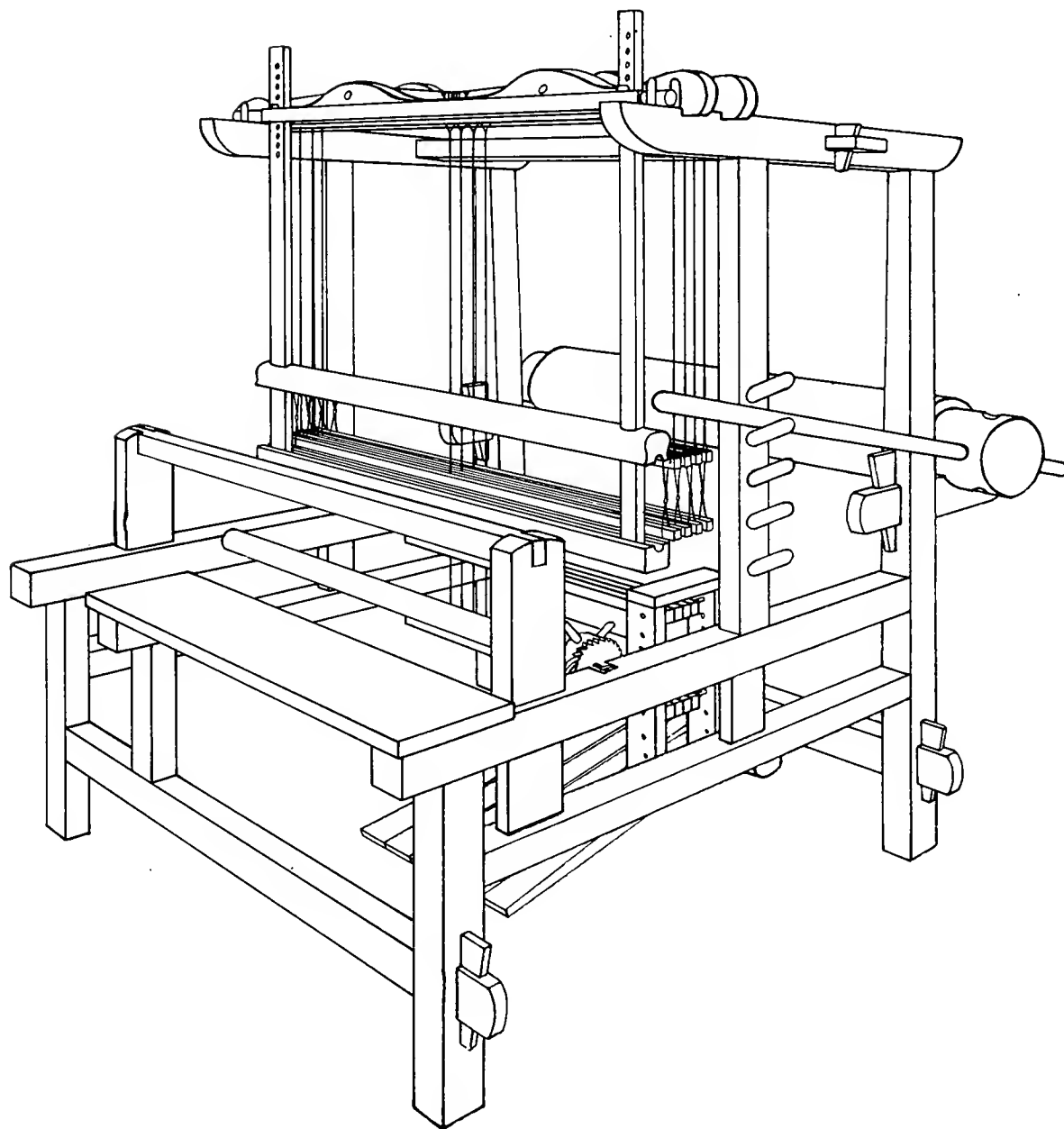


Fig. 223

Six-Harness Loom

Fig. 226

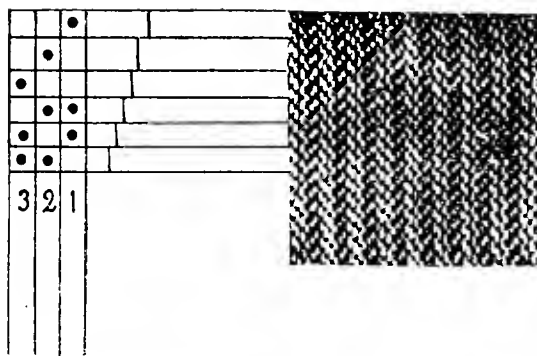


Fig. 227

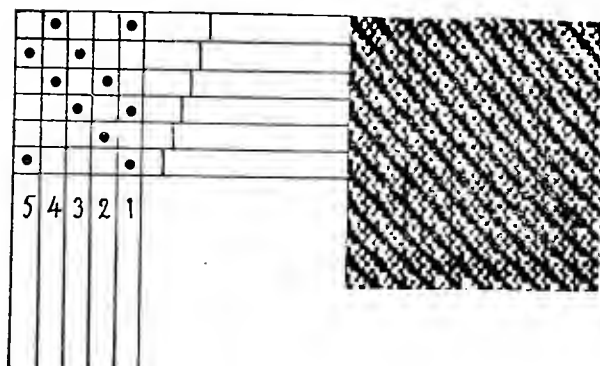
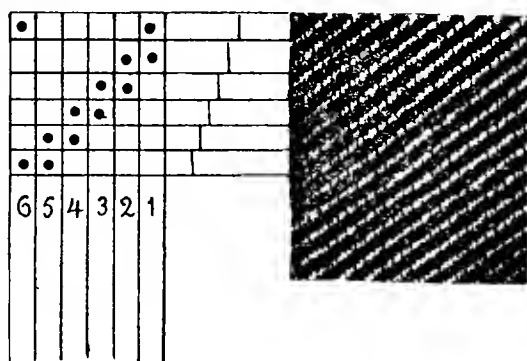


Fig. 228



The Swedish loom, as described and illustrated in this manual, is constructed in such a way as to permit of additional parts making possible the production of many complicated patterns. The drawing shown in Fig. 220 shows the construction of parts which makes easy the weaving with six harnesses.

The various drafts in six harnesses which follow have been very carefully worked out and found practical in every respect. Among the drafts given are those suited to upholstering, dress goods, toweling, heavy suiting, coats, etc. The interested weaver will find no end of suggestions. This, together with a little originality, will greatly simplify the working out of new and attractive patterns.

It is not necessary to confine the work only to certain materials. Many times a pattern worked out in the finest of threads may be worked out in a very coarse thread and made to serve an entirely different purpose from what it was originally intended.

To enjoy weaving great care must be exercised in the "tie-up." All parts must be made to pull evenly. To do this the blocking cord must be used and the method of tying must be observed in order to adjust readily.

Fig. 229

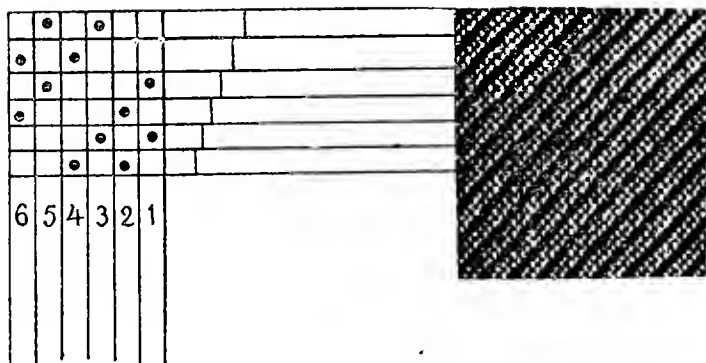


Fig. 232

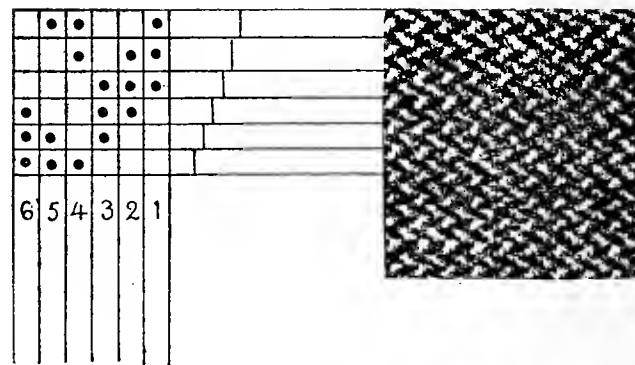


Fig. 230

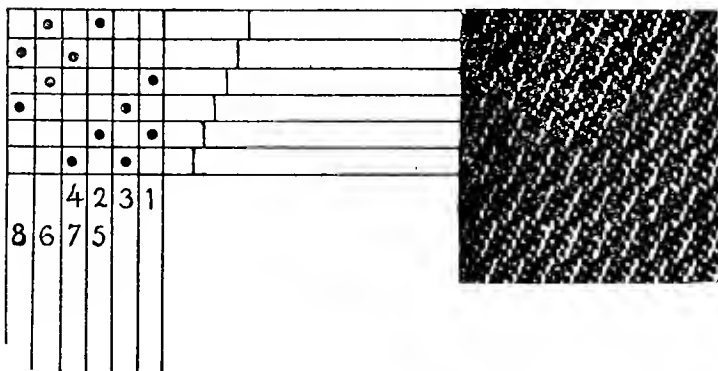


Fig. 233

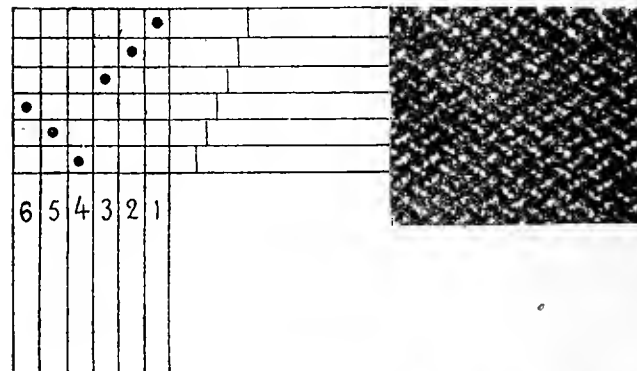


Fig. 231

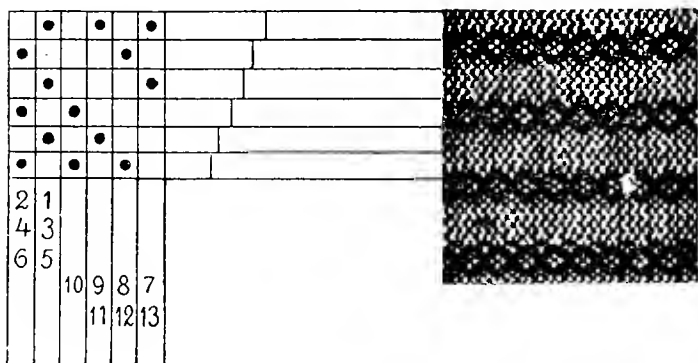


Fig. 234

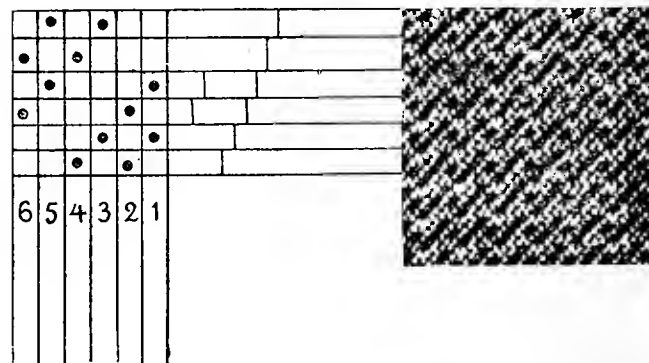


Fig. 241

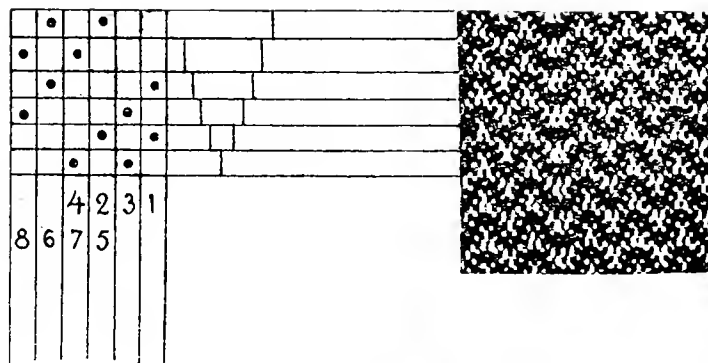


Fig. 242

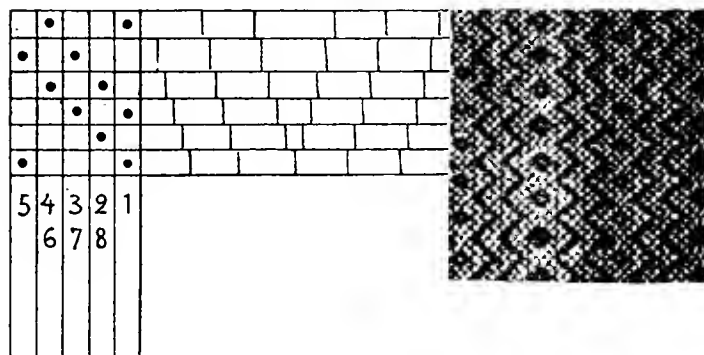
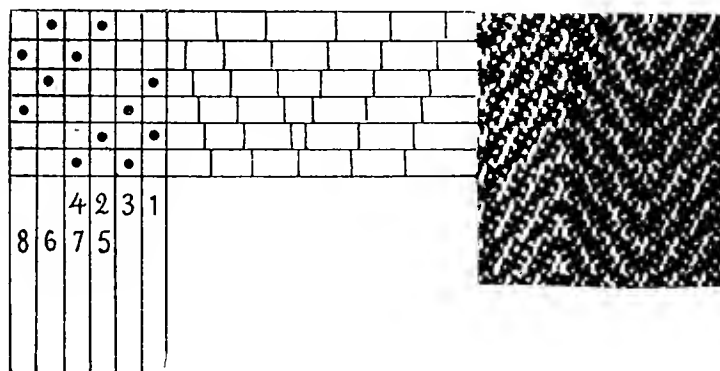


Fig. 243



Eight Harness Loom

The loom as described for six harnesses will answer the description for the eight harness loom. The parts necessary are described in Figs. 220, 221 and 222. These parts are shown properly placed in the complete loom on page 119, Fig. 223.

The next group of patterns from Fig. 244 to Fig. 391 inclusive, concerns the eight harness loom. The threading and tie-up have been so carefully described in previous patterns that there can be no difficulty in understanding the drafts for the eight harness patterns as here given. It will be found that the threading for many of the eight harness patterns is the same, the change in pattern being brought about by a change in the tie-up. One threading therefore makes it possible to produce a variety of patterns by changing only the order of treading.

Numerous interesting weaves which may be used for upholstery, suiting material, towels, etc., are produced.

Fig. 244

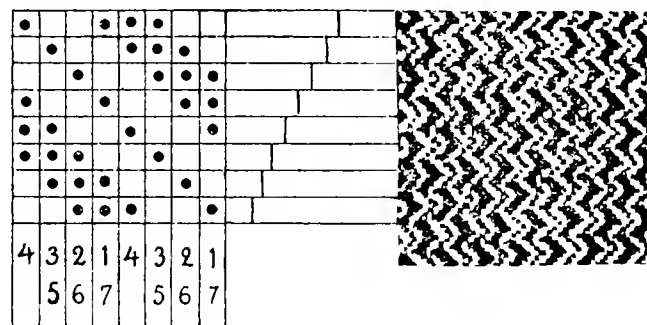


Fig. 247

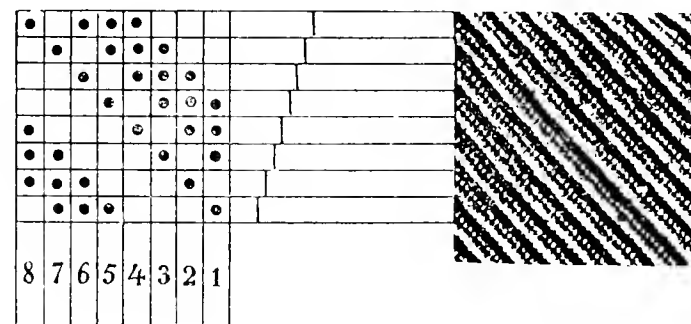


Fig. 245

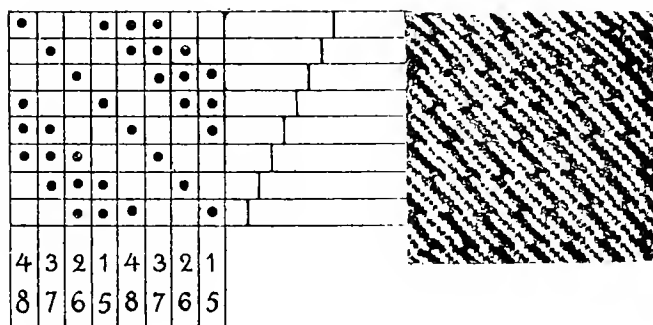


Fig. 248

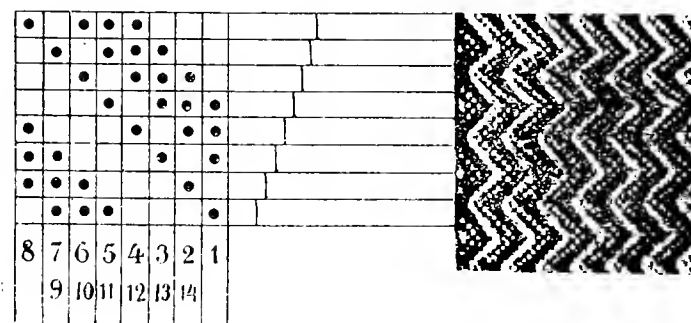


Fig. 246

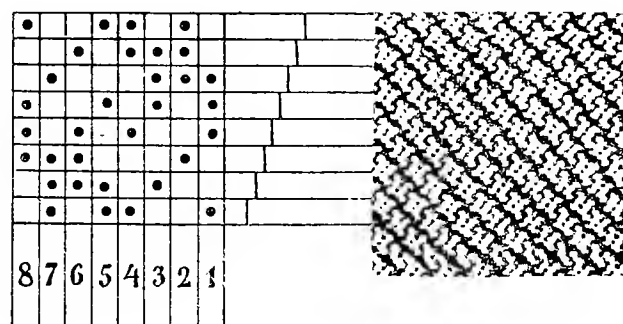


Fig. 249

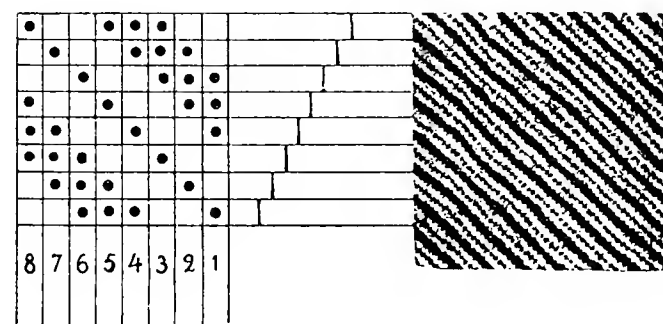


Fig. 250

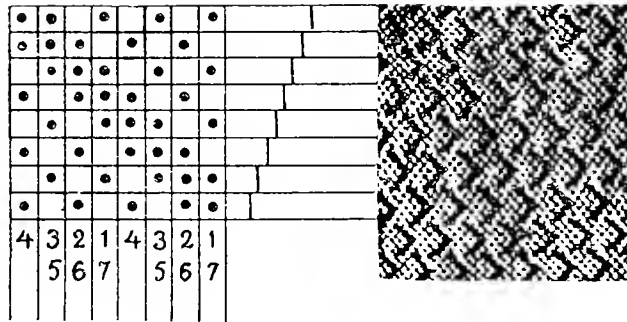


Fig. 253

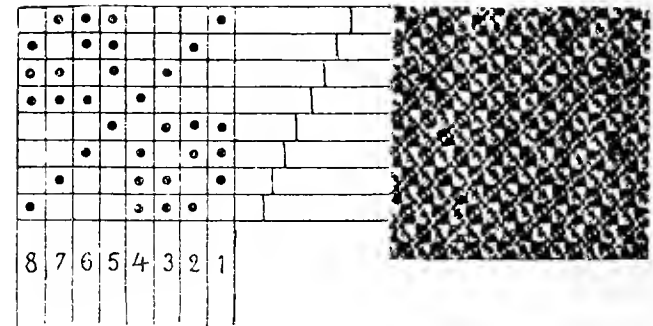


Fig. 251

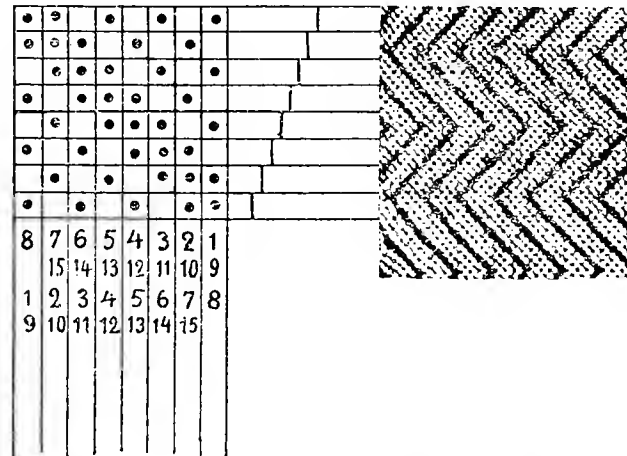


Fig. 254

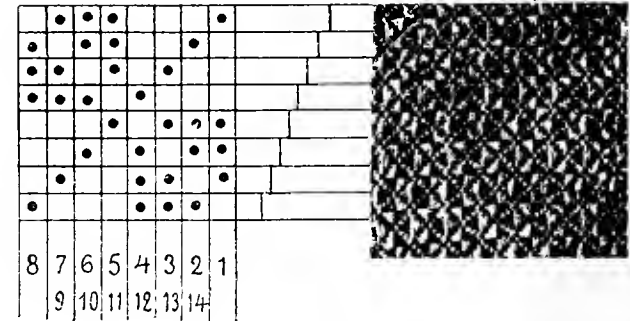


Fig. 252

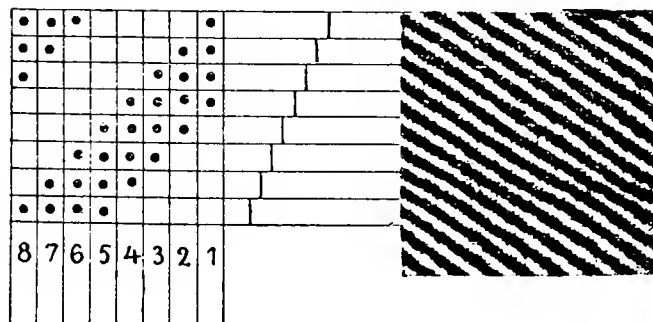


Fig. 255

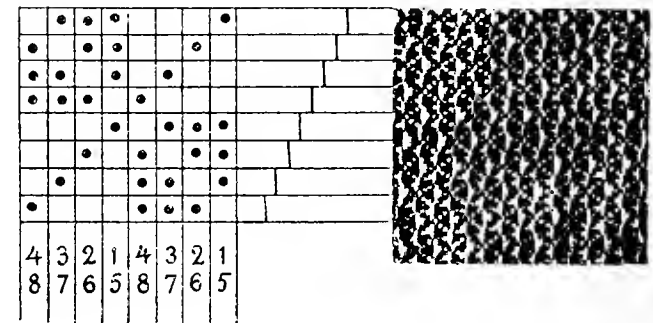


Fig. 256

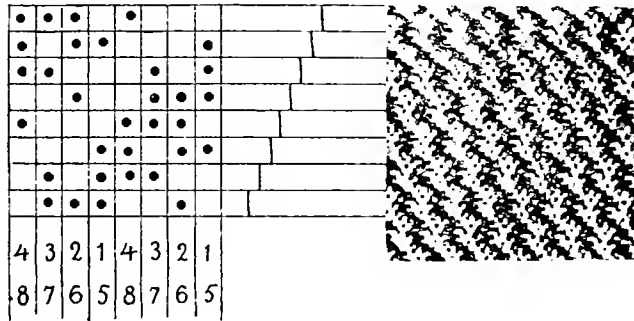


Fig. 259

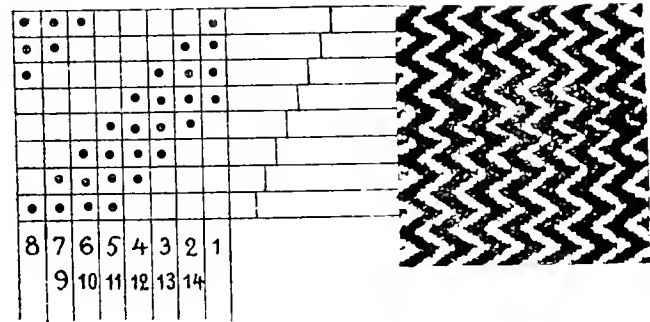


Fig. 257

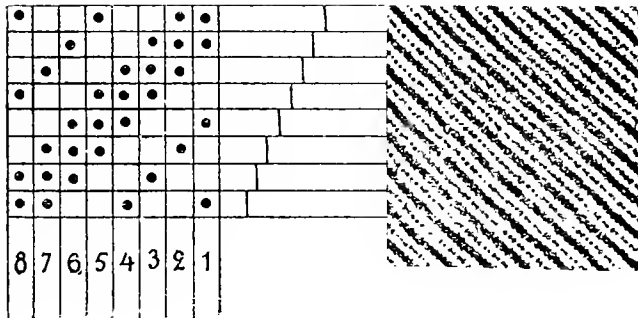


Fig. 260

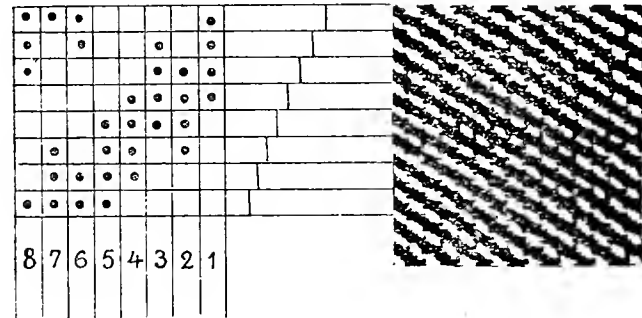


Fig. 258

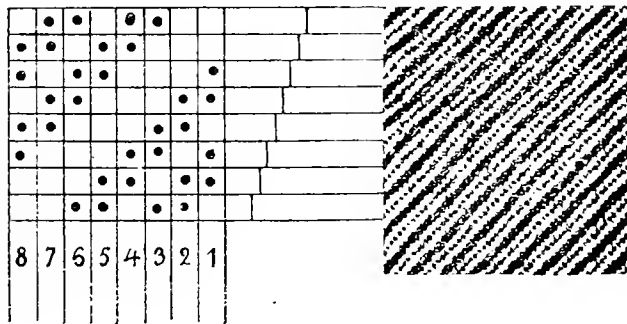
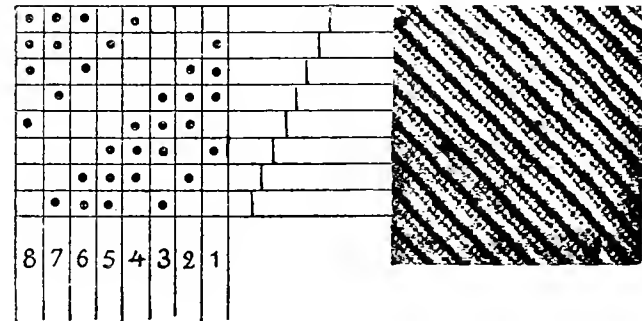


Fig. 261



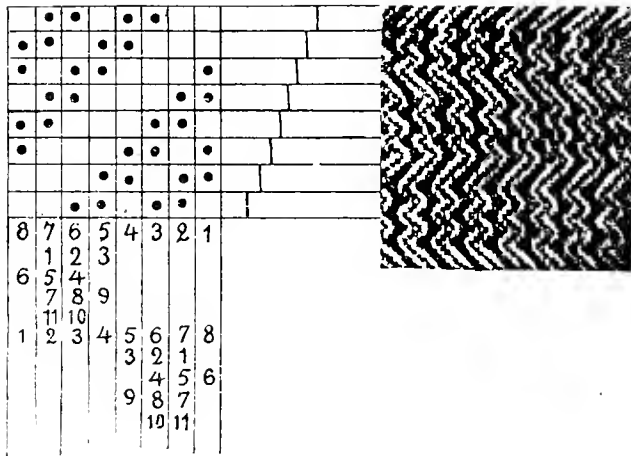


Fig. 262

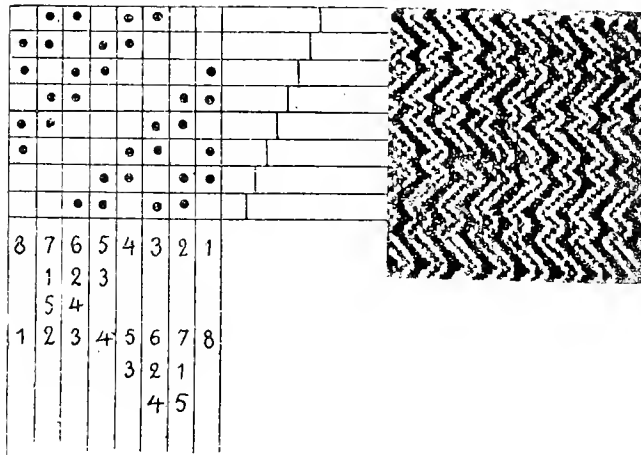


Fig. 263

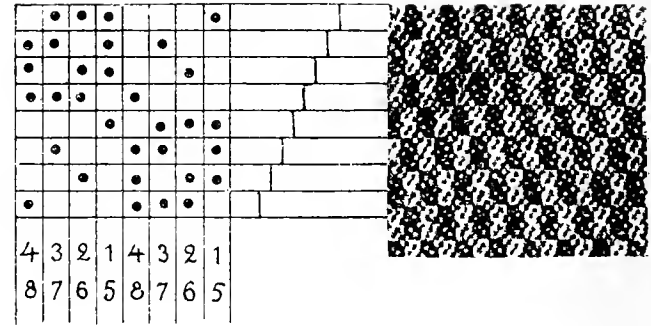


Fig. 264

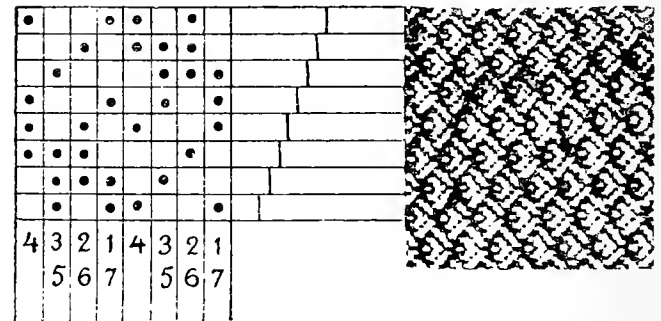


Fig. 265

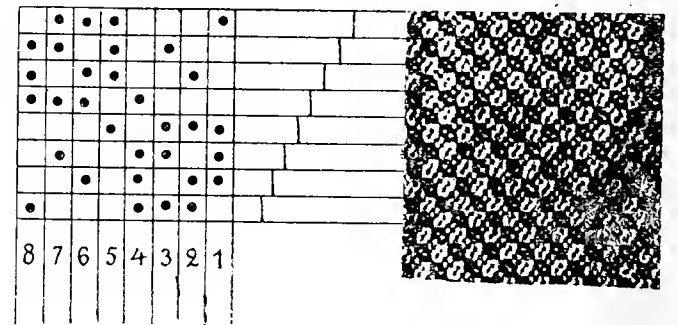


Fig. 266

Fig. 267

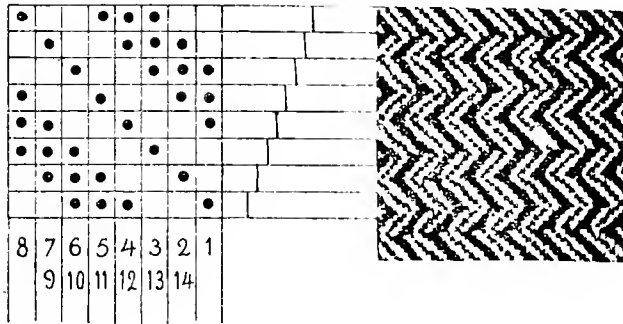


Fig. 270

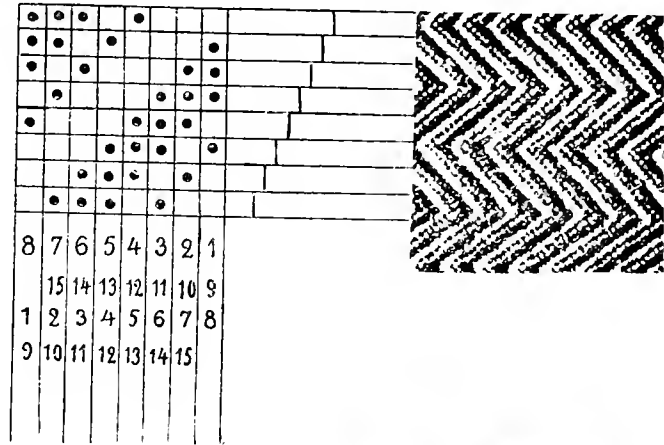


Fig. 268

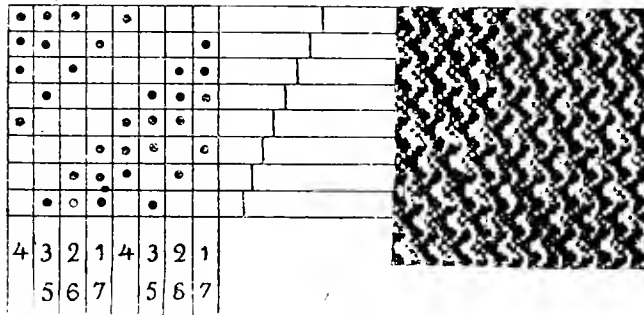


Fig. 271

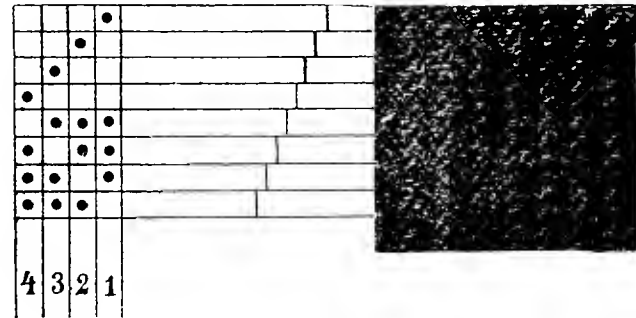


Fig. 269

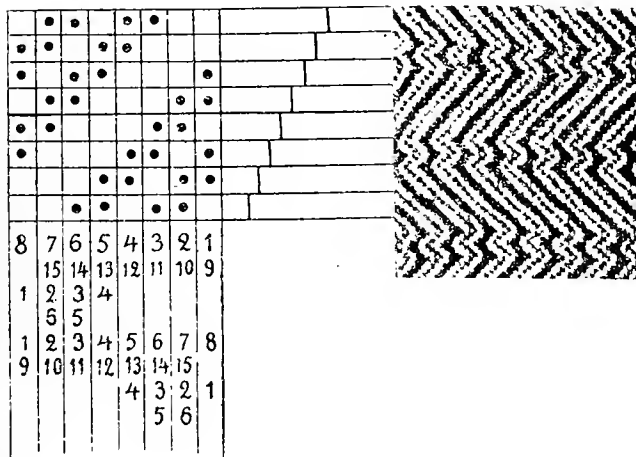


Fig. 272

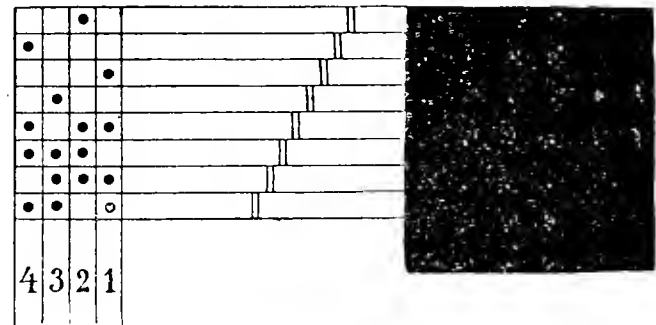


Fig. 273

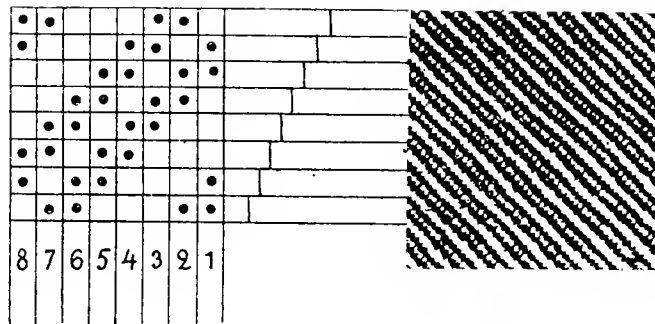


Fig. 276

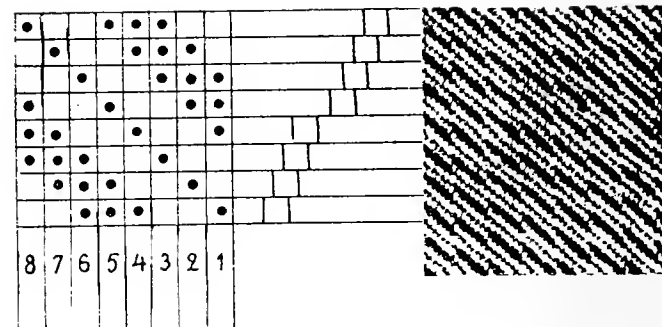


Fig. 274

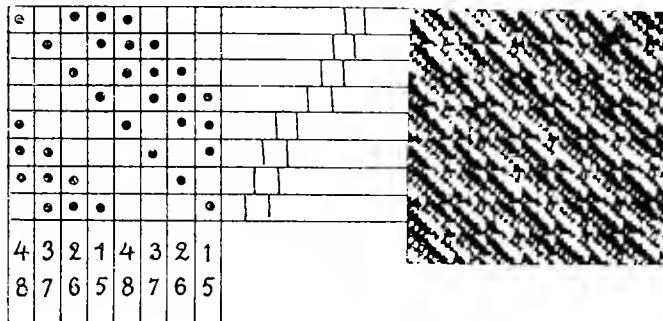


Fig. 277

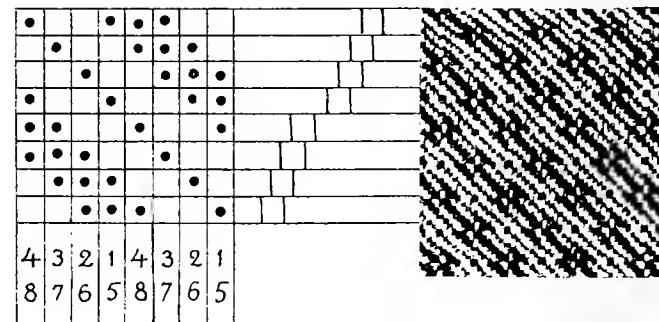


Fig. 275

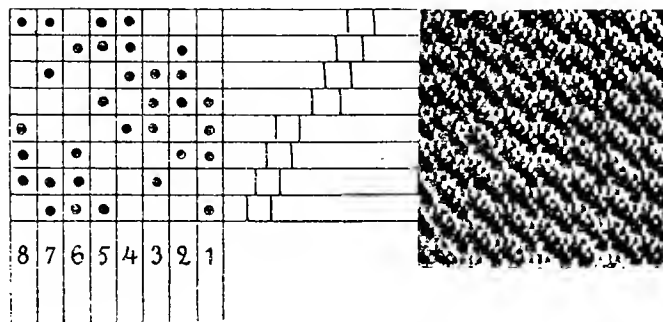


Fig. 278

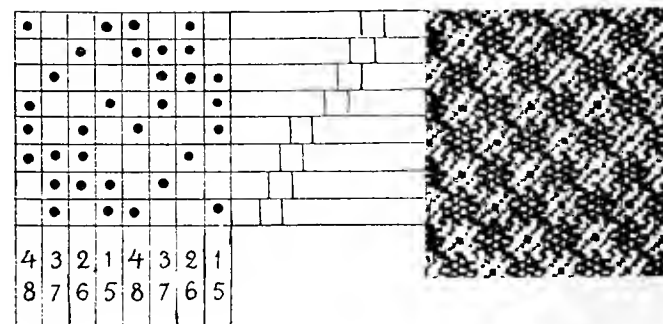


Fig. 279

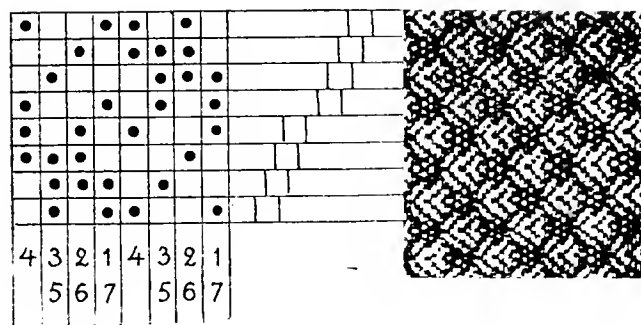


Fig. 282

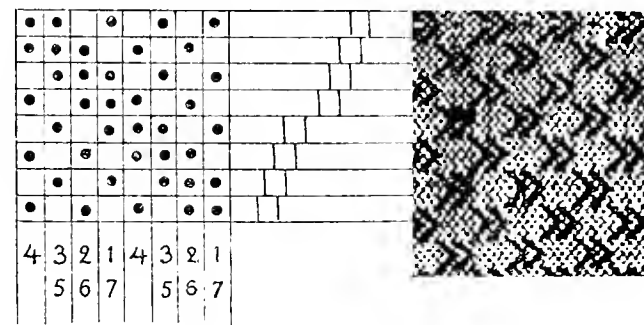


Fig. 280

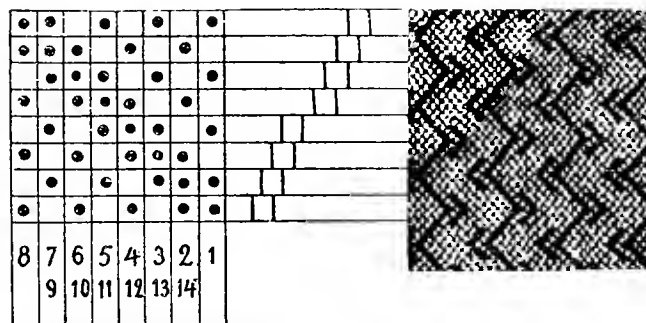


Fig. 283

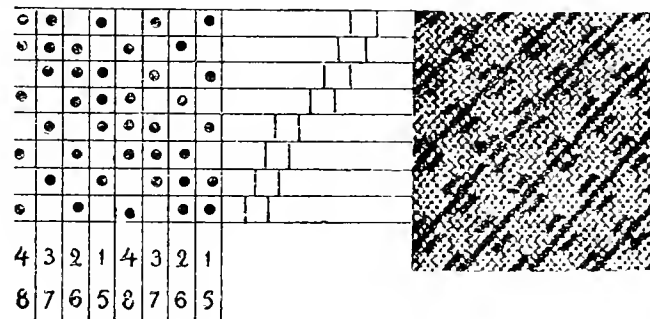


Fig. 281

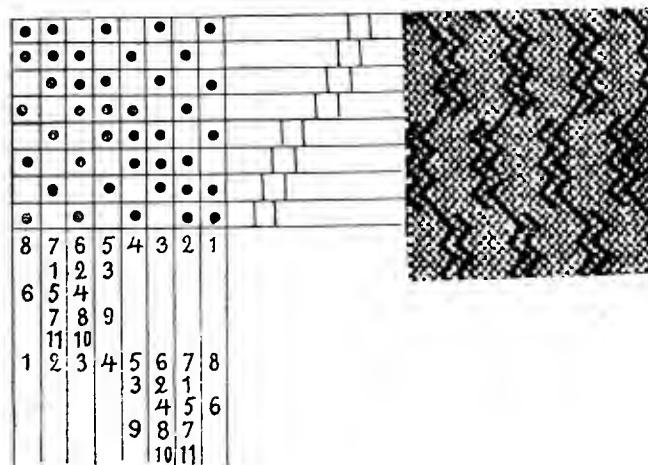


Fig. 284

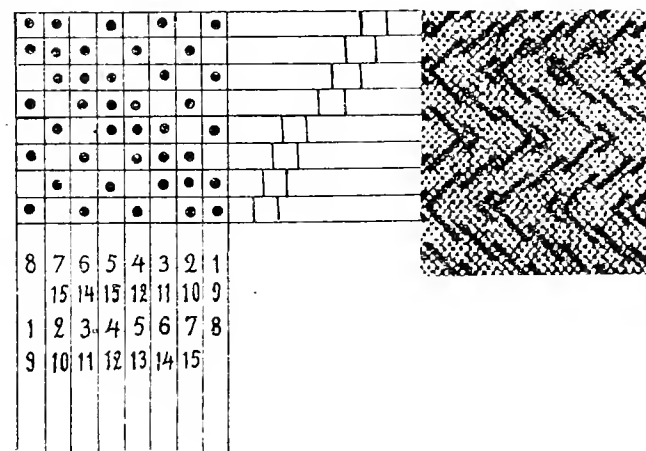


Fig. 296

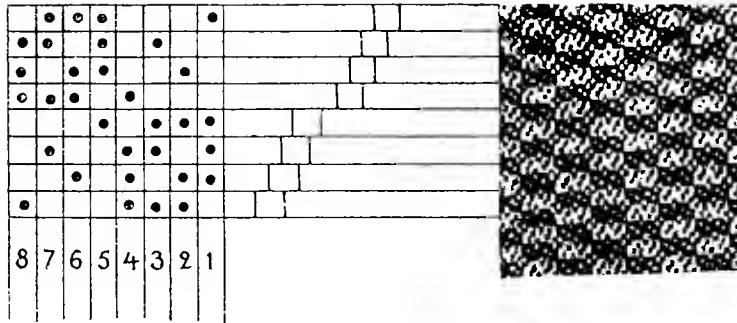


Fig. 299

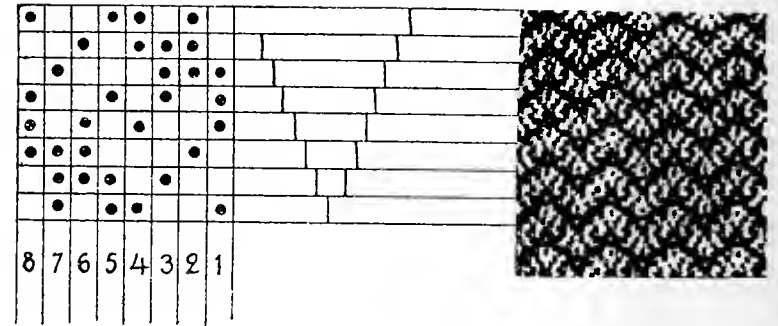


Fig. 297

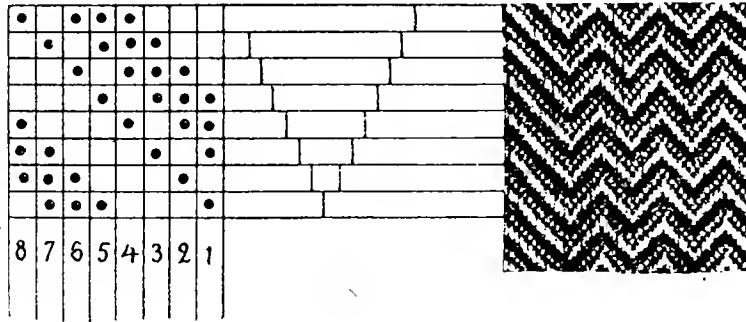


Fig. 300

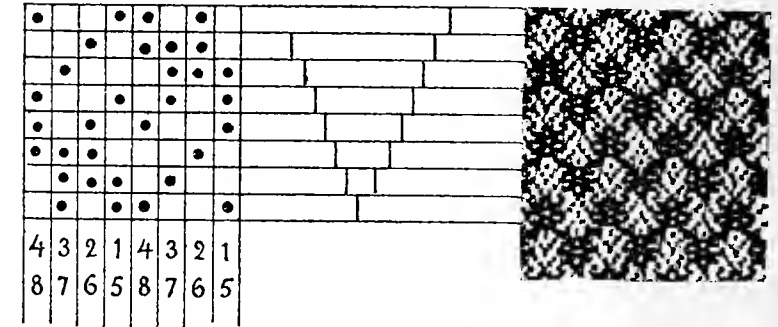


Fig. 298

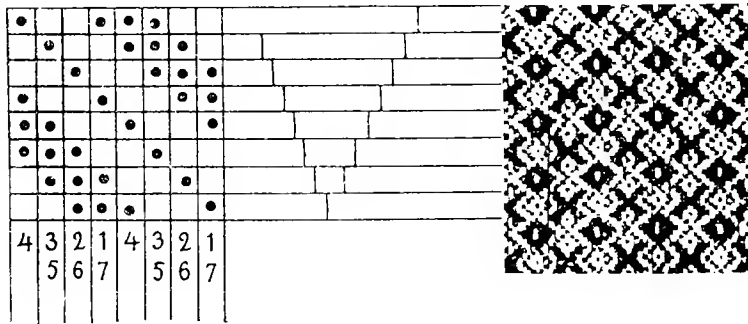


Fig. 301

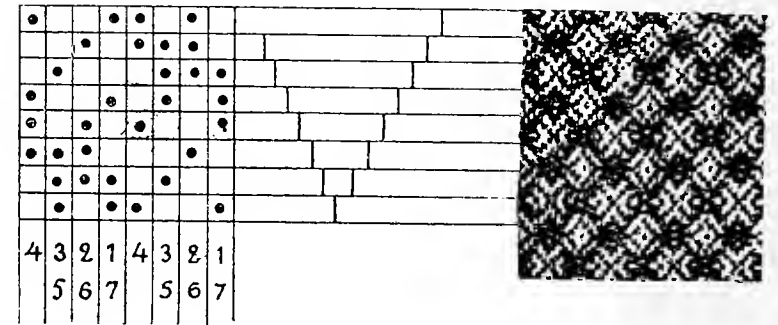


Fig. 302

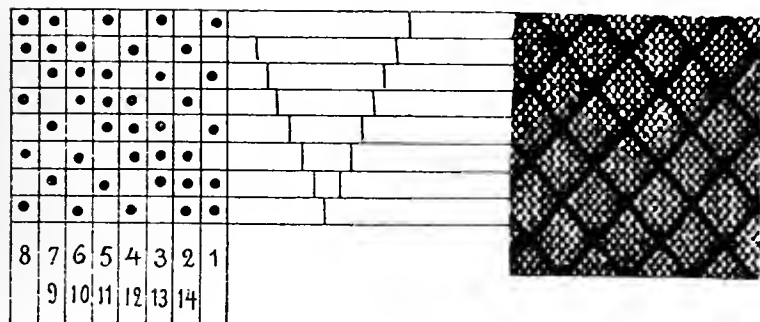


Fig. 305

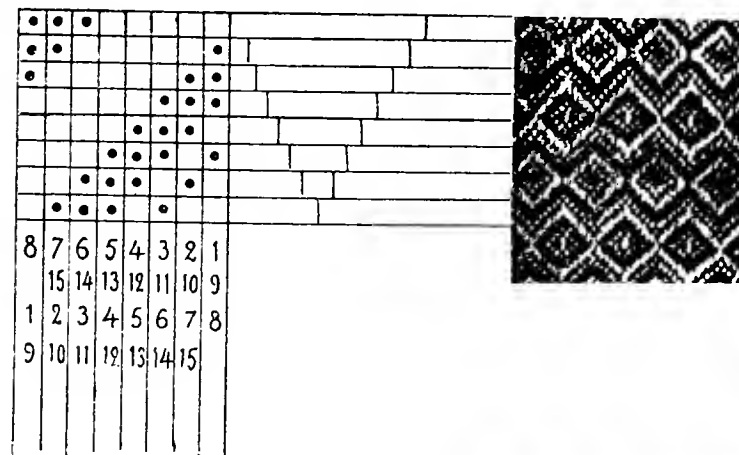


Fig. 303

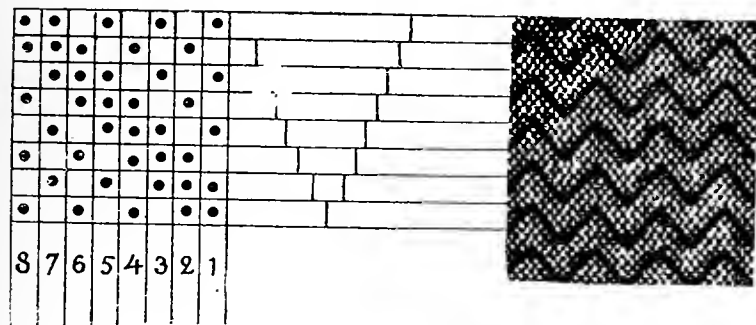


Fig. 306

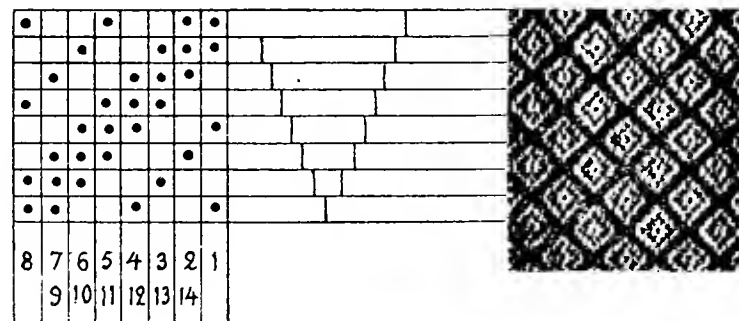


Fig. 304

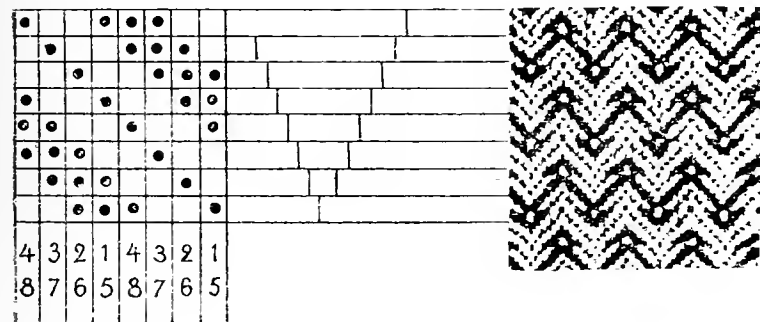


Fig. 307

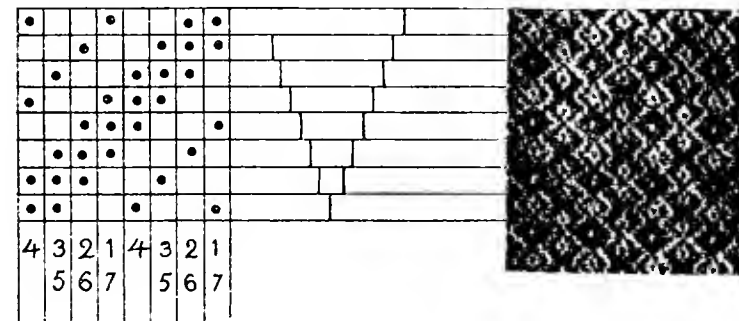


Fig. 314

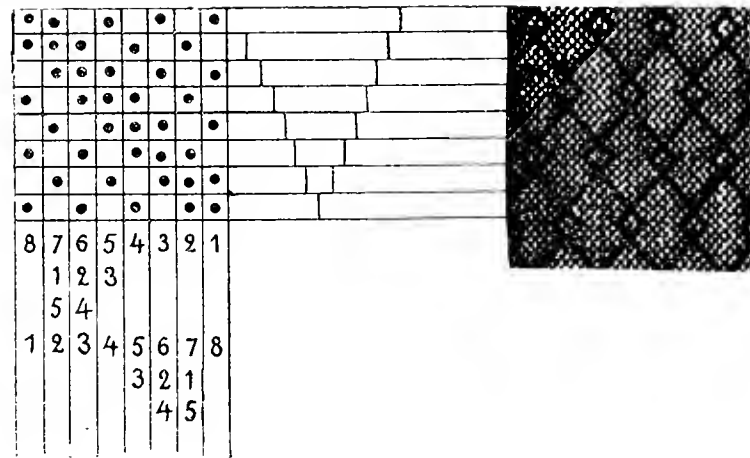
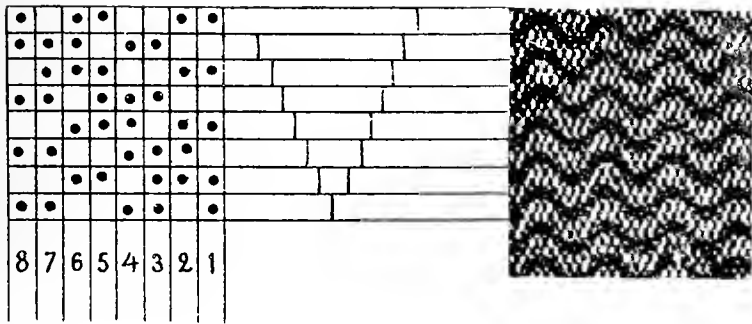


Fig. 317

Fig. 315

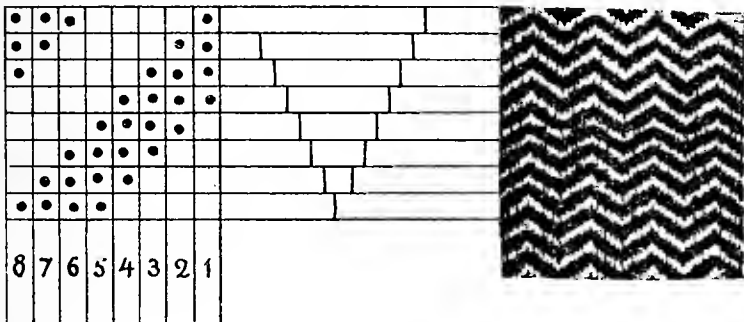


Fig. 316

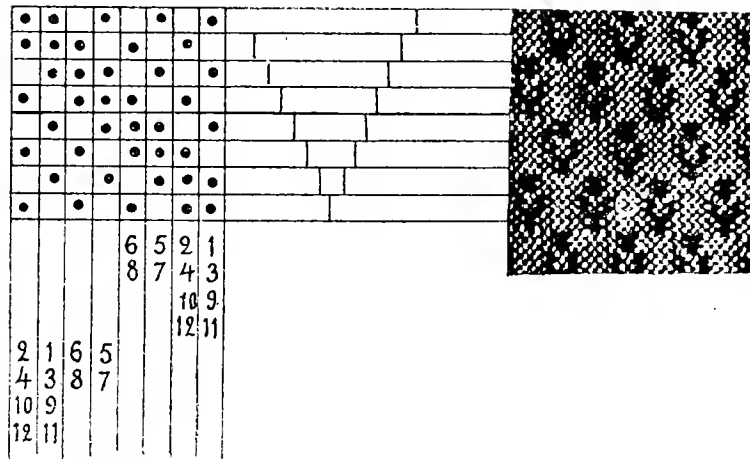
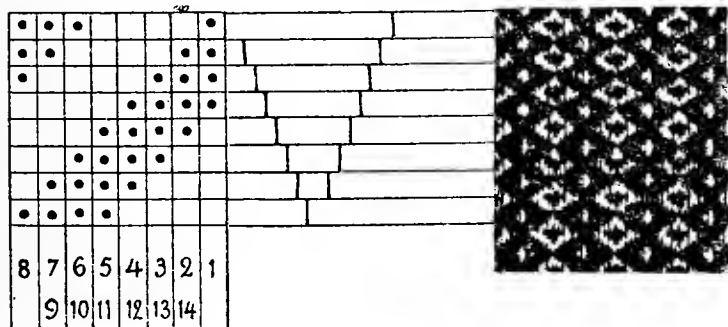


Fig. 318

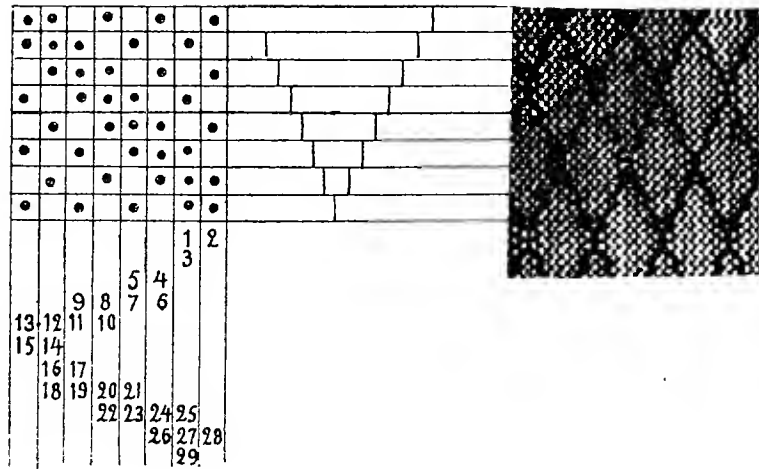


Fig. 319

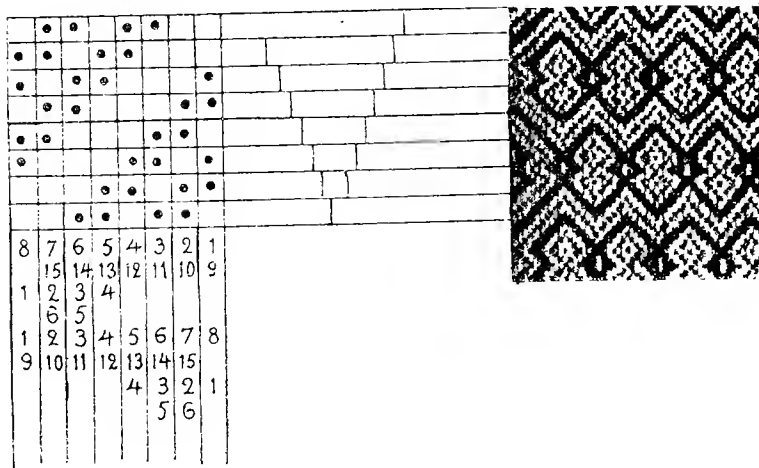


Fig. 320

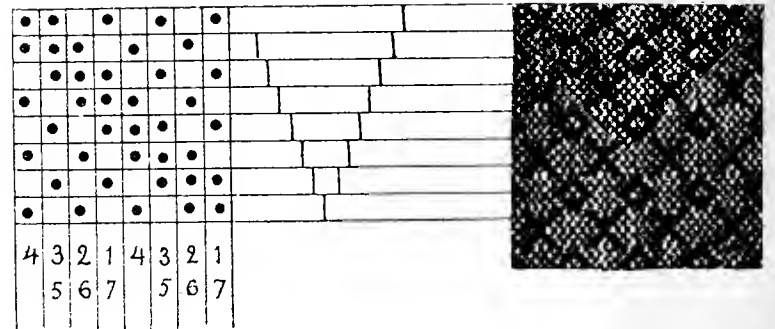


Fig. 321

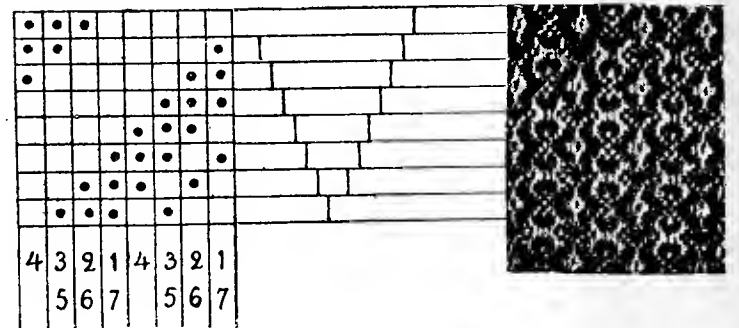


Fig. 322

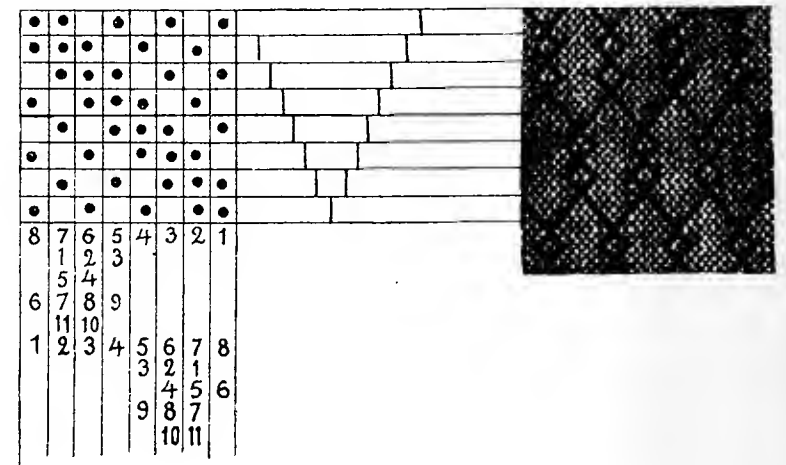


Fig. 323

Fig. 330

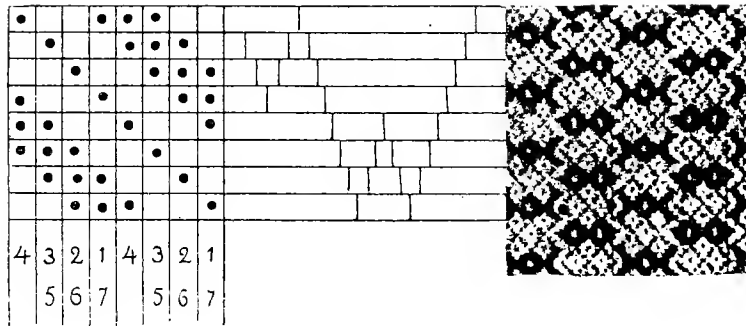


Fig. 333

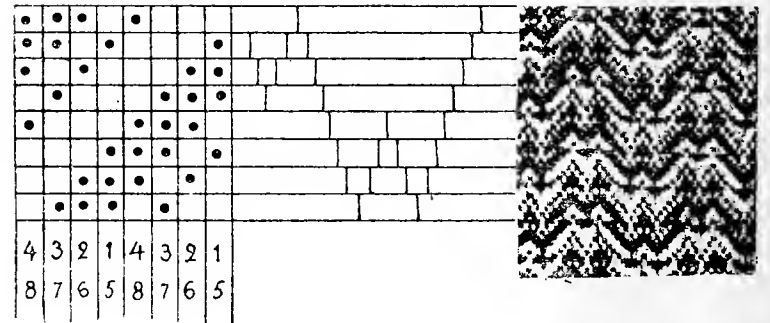


Fig. 331

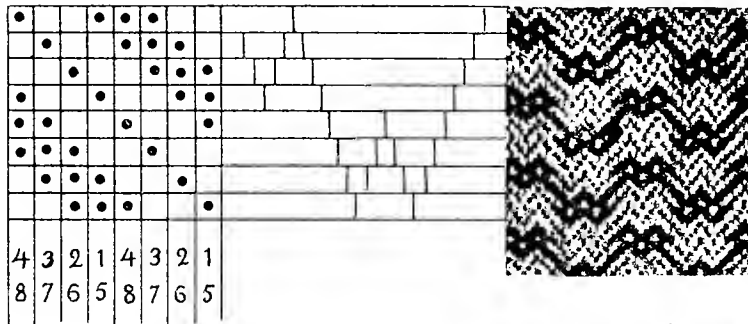


Fig. 334

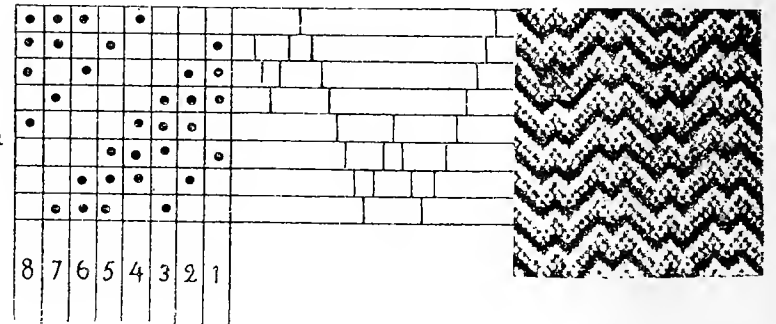


Fig. 332

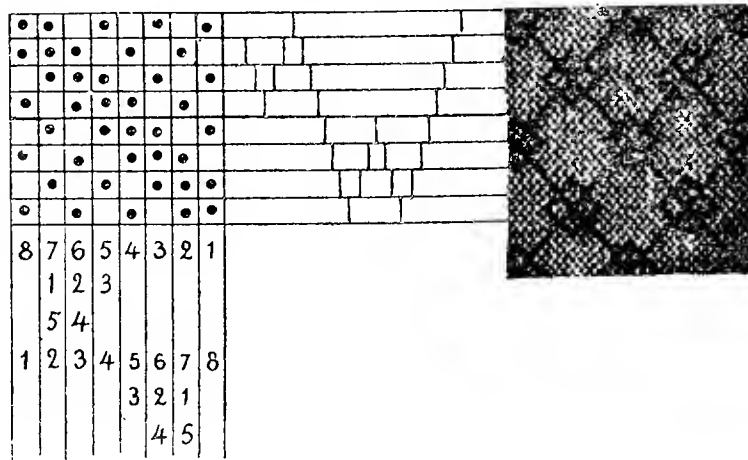


Fig. 335

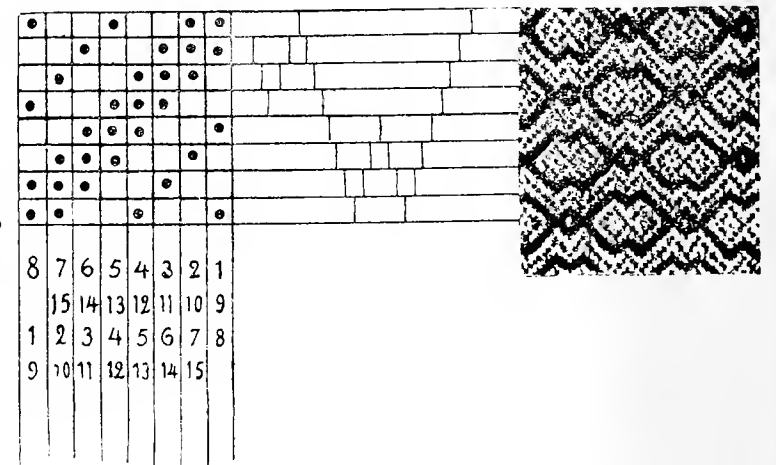


Fig. 336

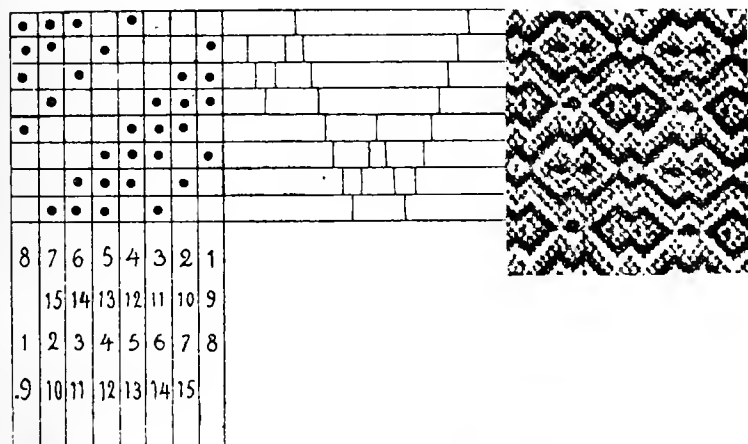


Fig. 339

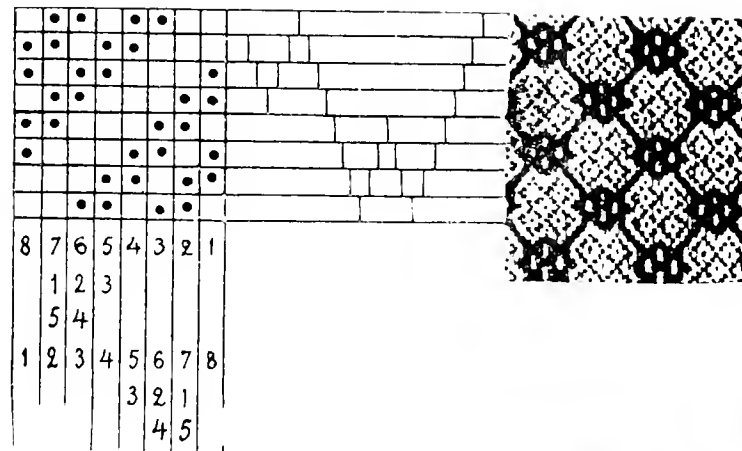


Fig. 337

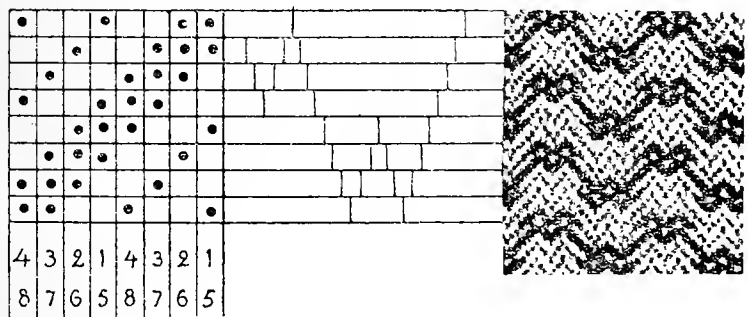


Fig. 340

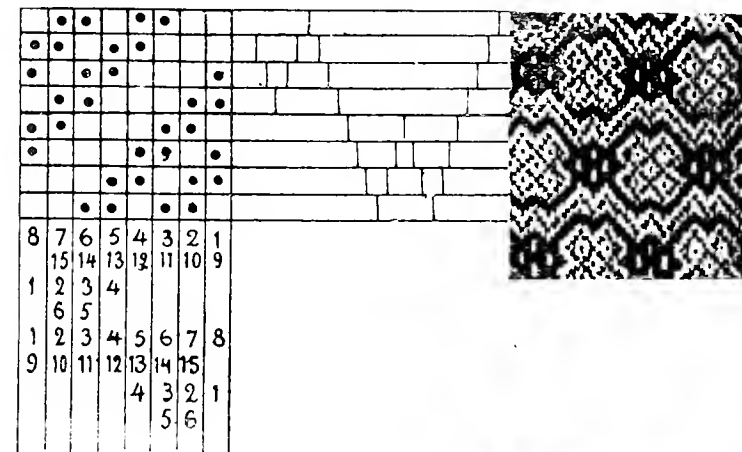


Fig. 338

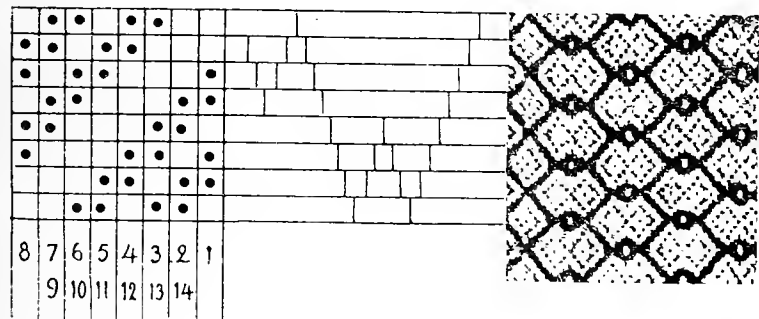


Fig. 341

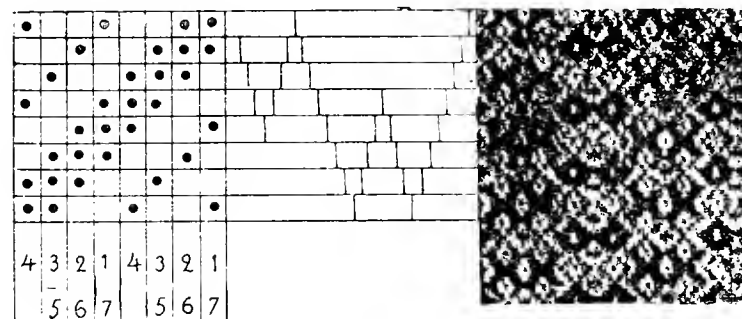


Fig. 342

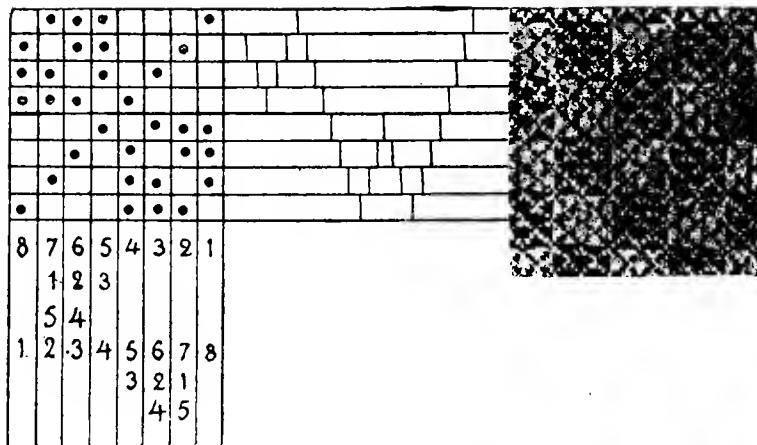


Fig. 345

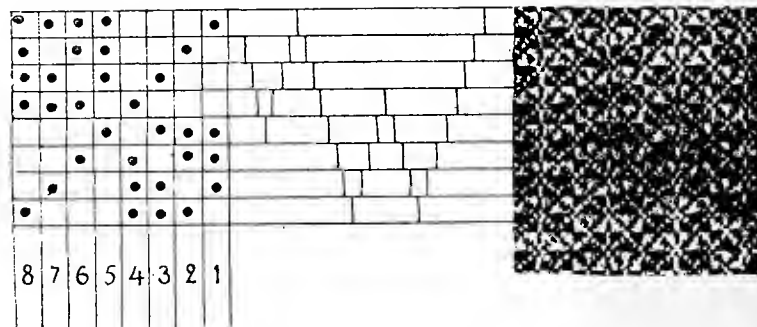


Fig. 343

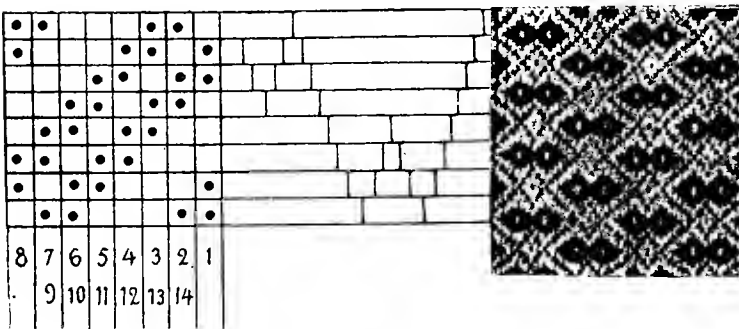


Fig. 346

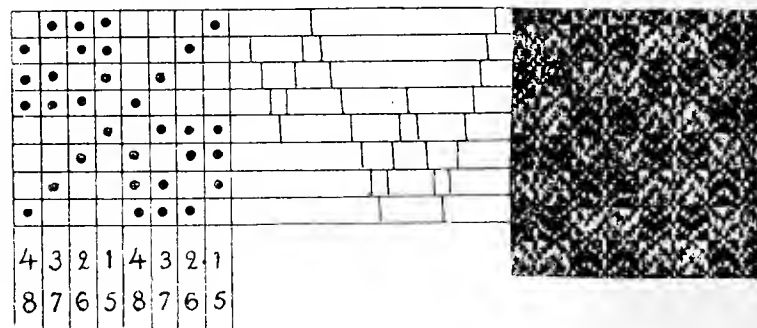


Fig. 344

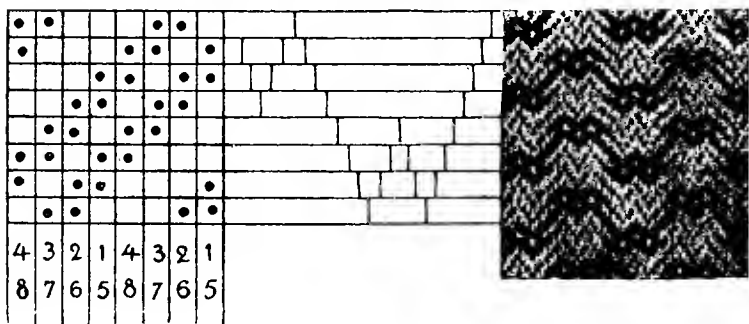
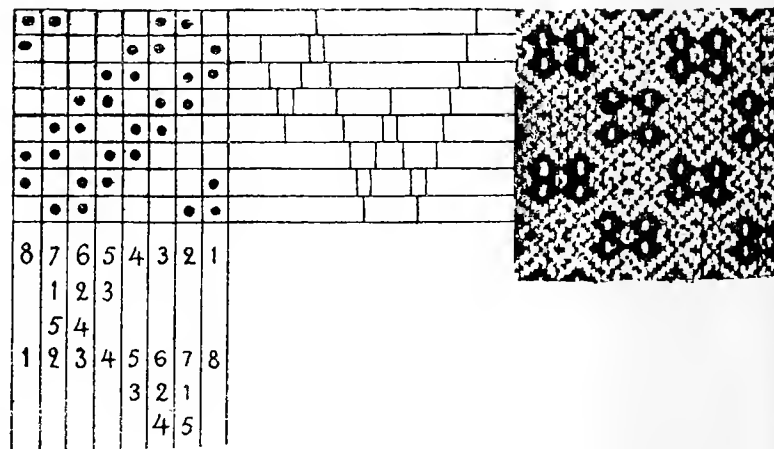


Fig. 347



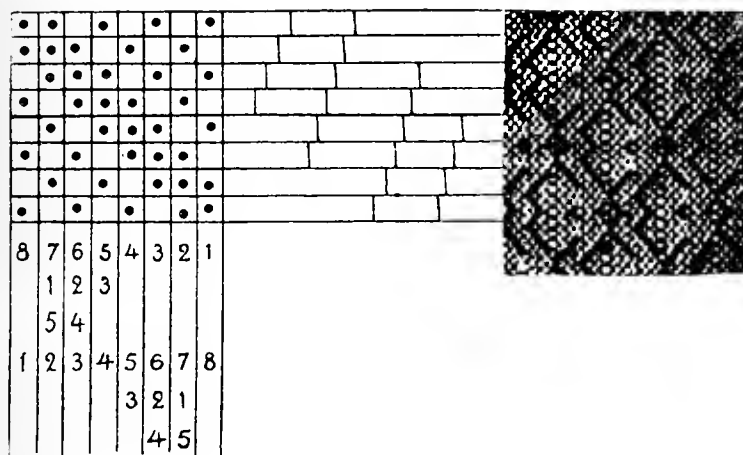


Fig. 348

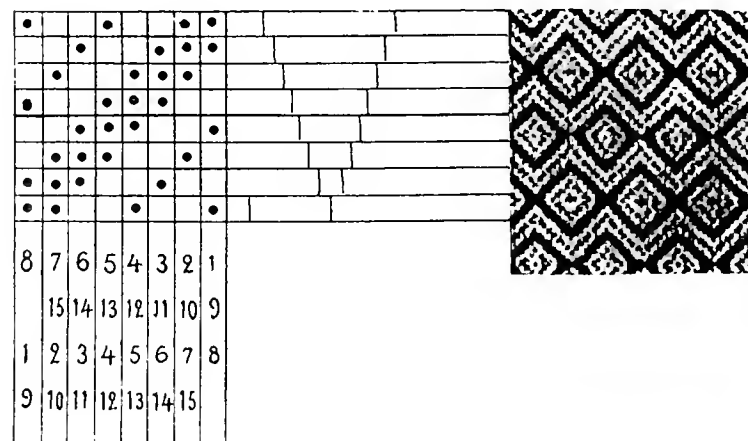


Fig. 350

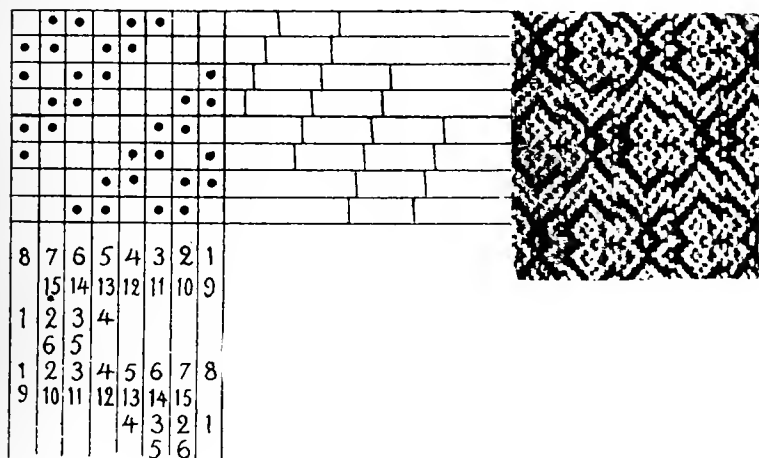


Fig. 349

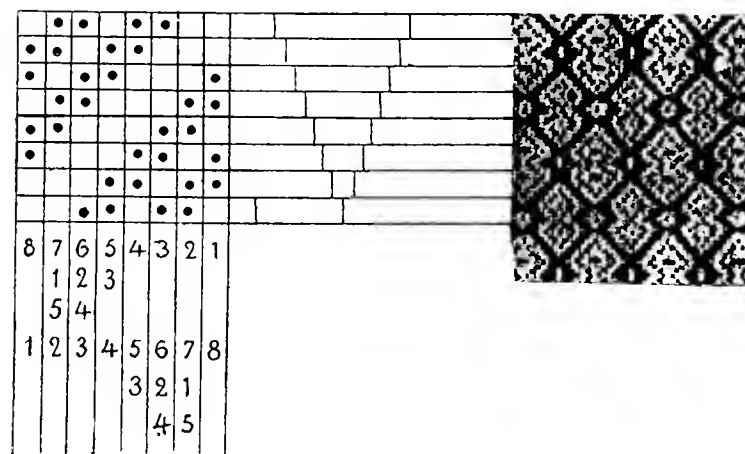


Fig. 351

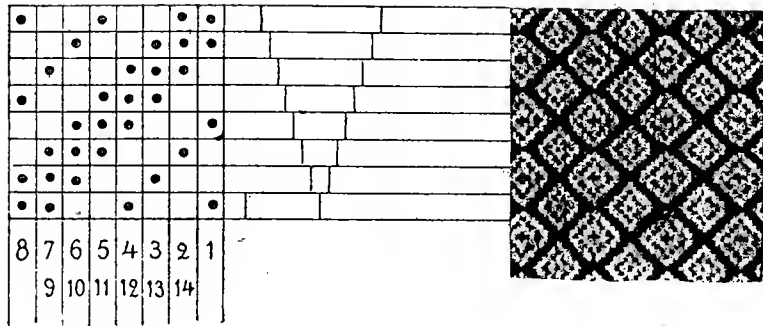


Fig. 352

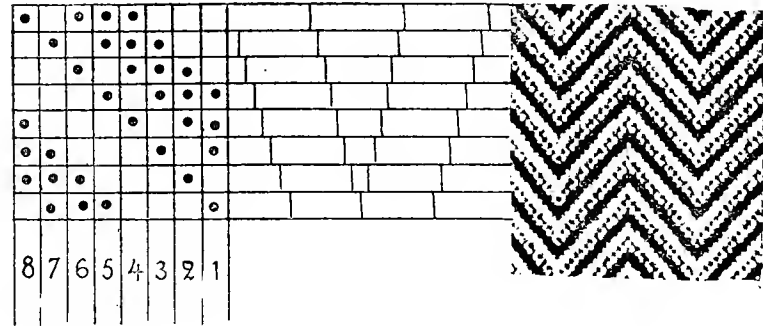


Fig. 353

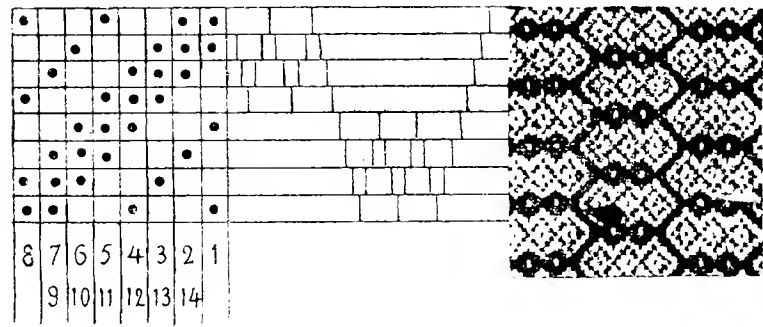


Fig. 354

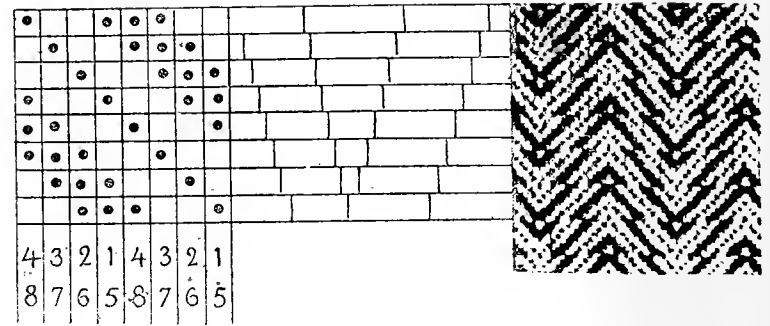


Fig. 355

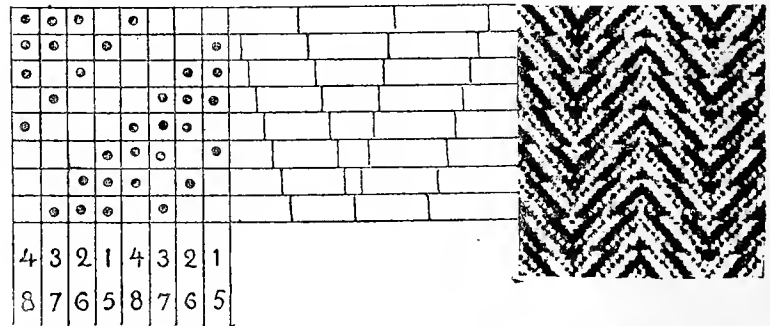


Fig. 356

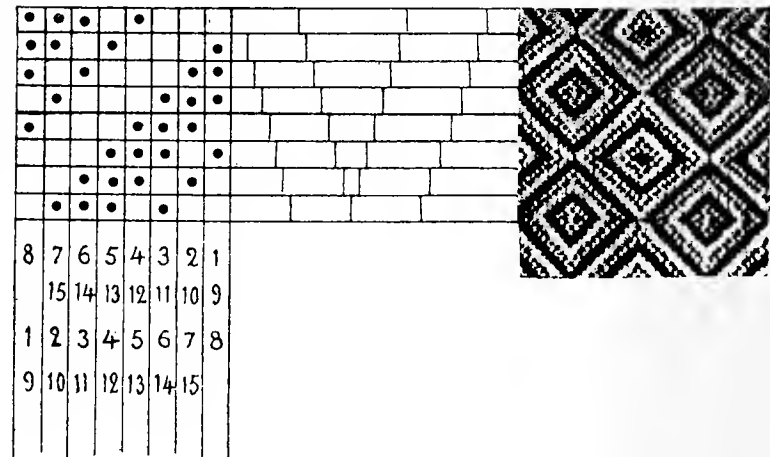


Fig. 357

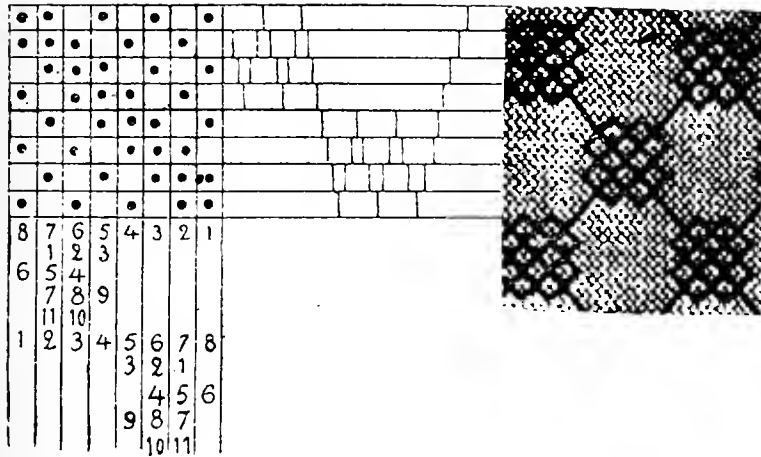


Fig. 358

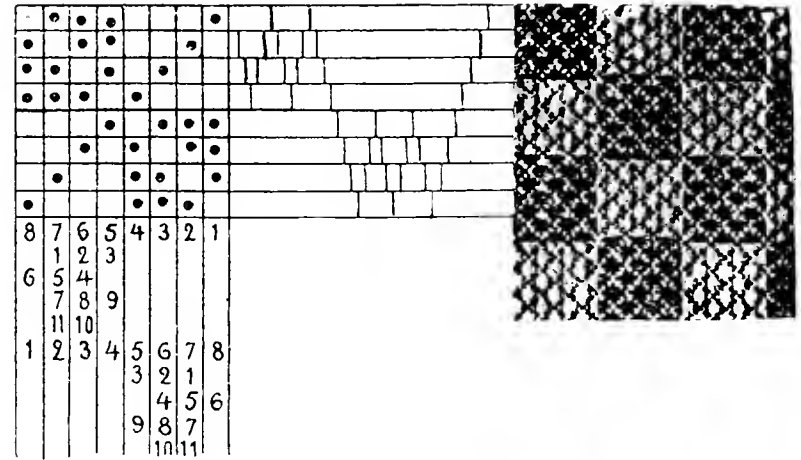


Fig. 360

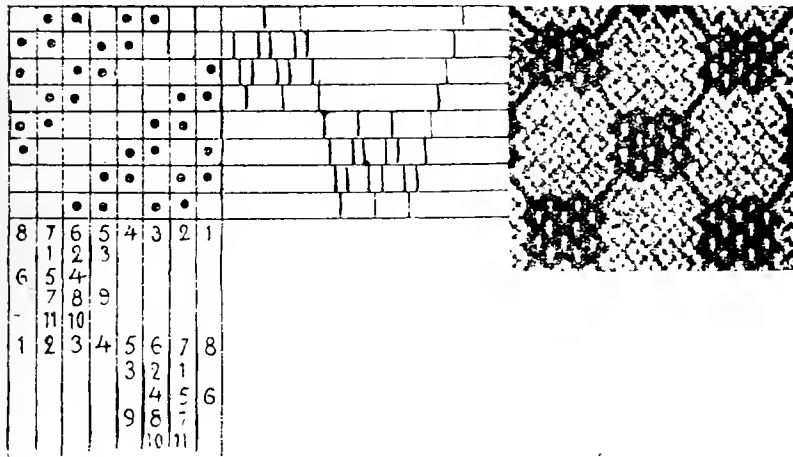


Fig. 359

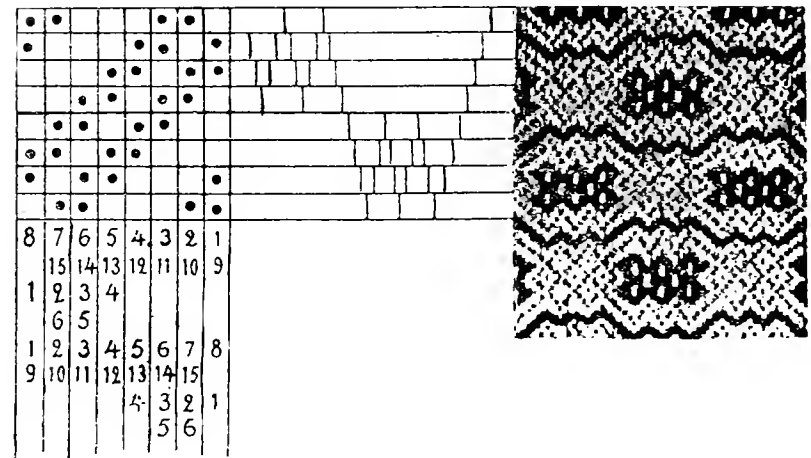


Fig. 361

Fig. 362

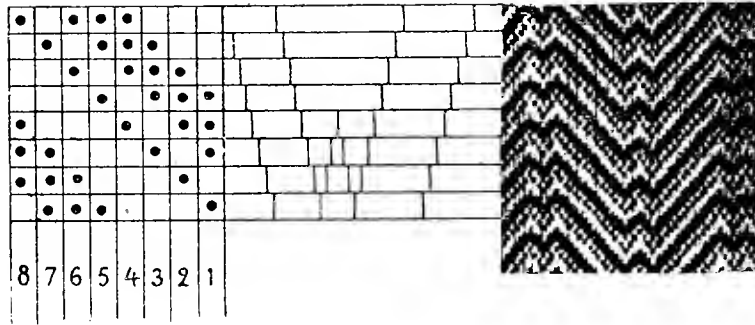


Fig. 365

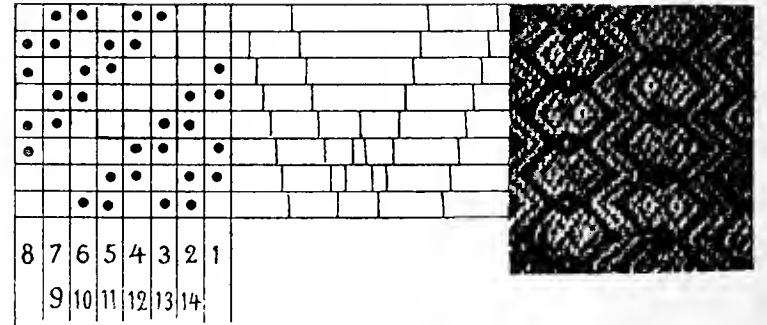


Fig. 363

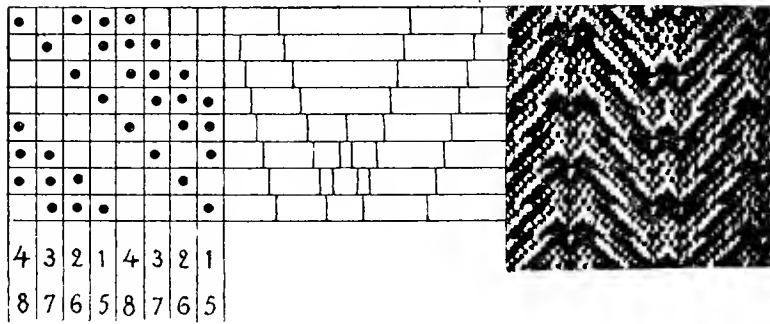


Fig. 366

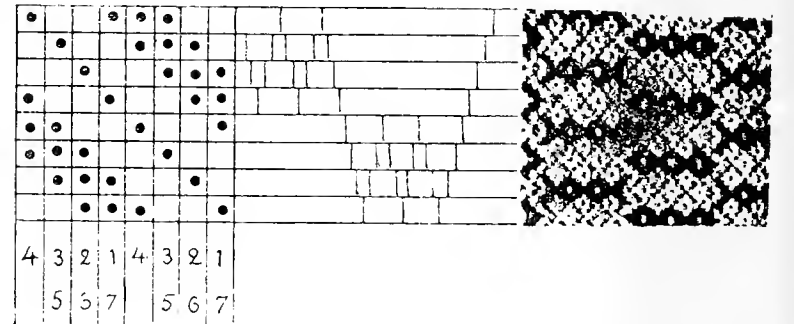


Fig. 364

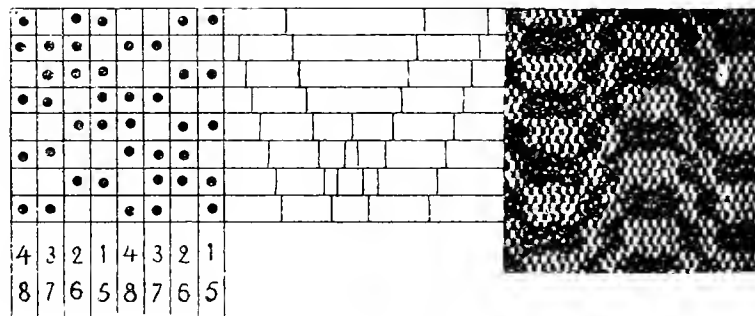


Fig. 367

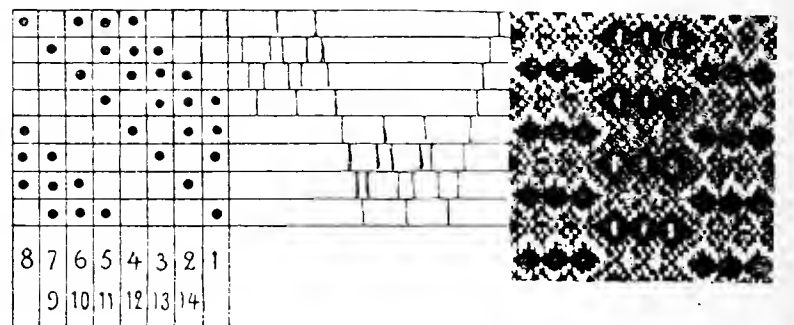


Fig. 368

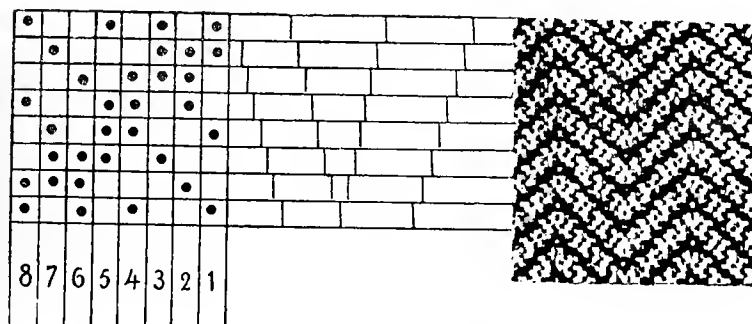


Fig. 369

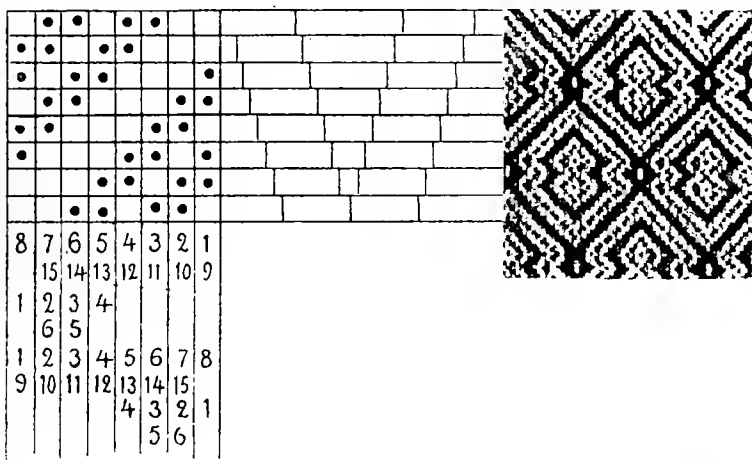


Fig. 370

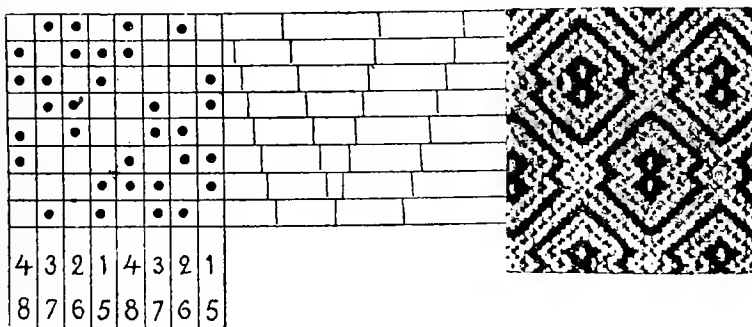


Fig. 371

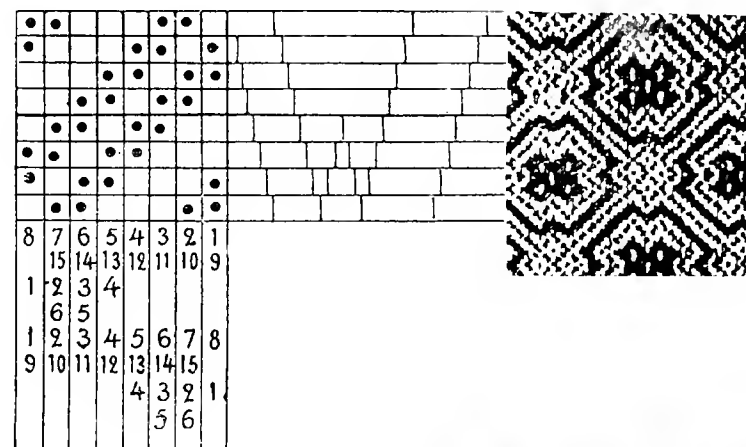


Fig. 372

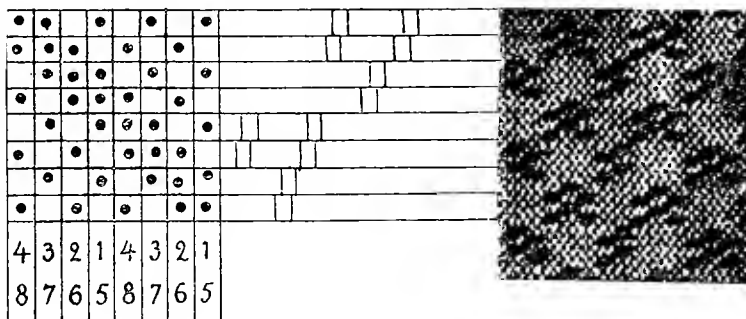


Fig. 373

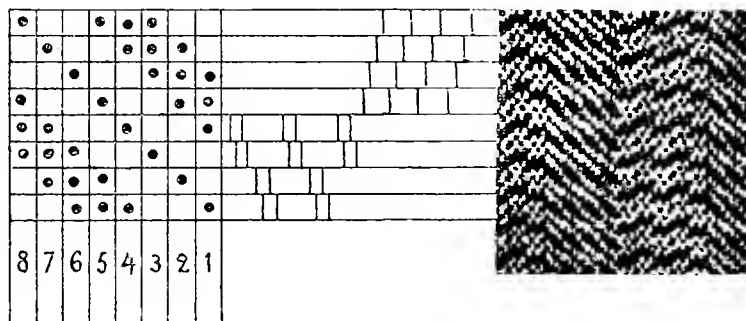


Fig. 380

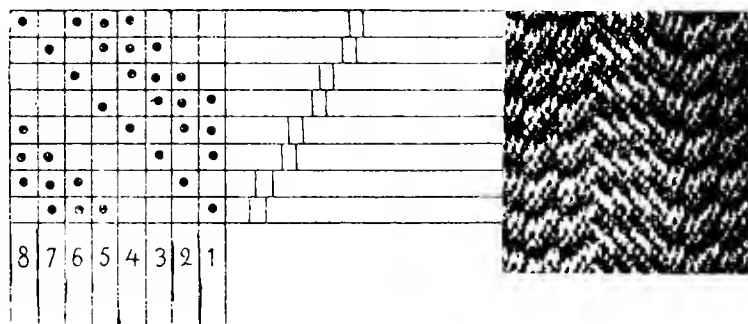


Fig. 383

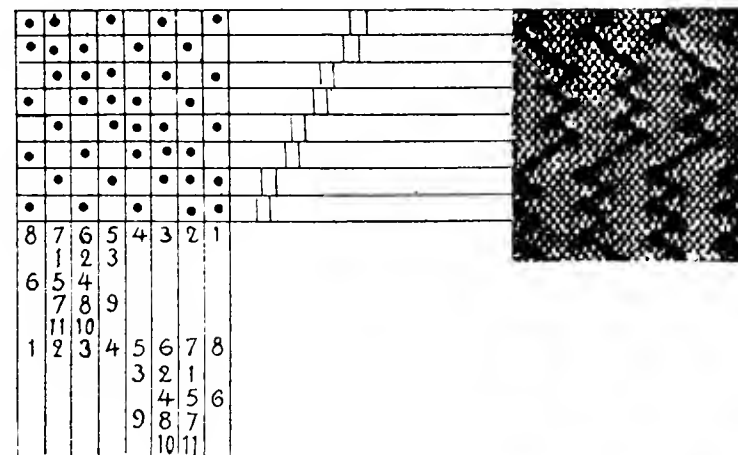


Fig. 381

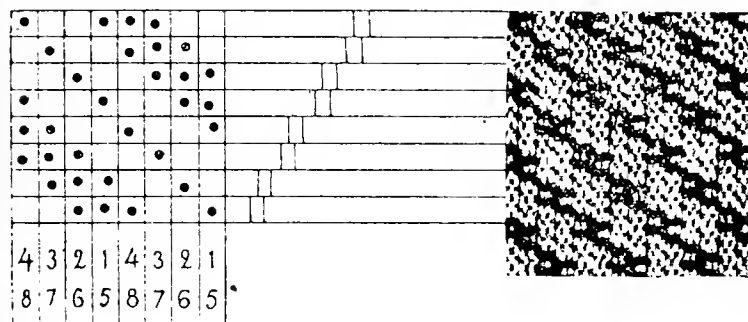


Fig. 384

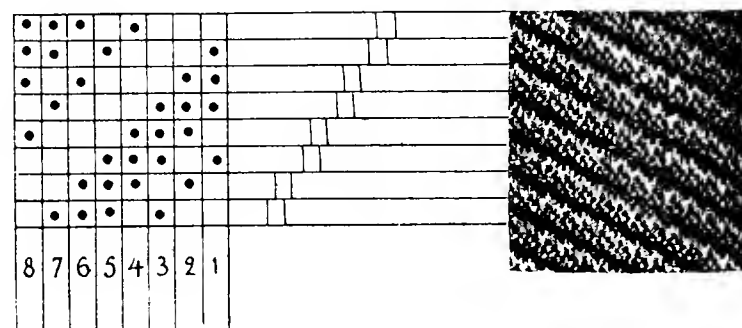


Fig. 382

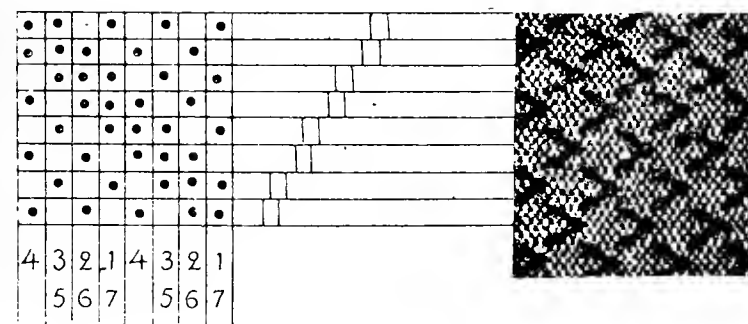
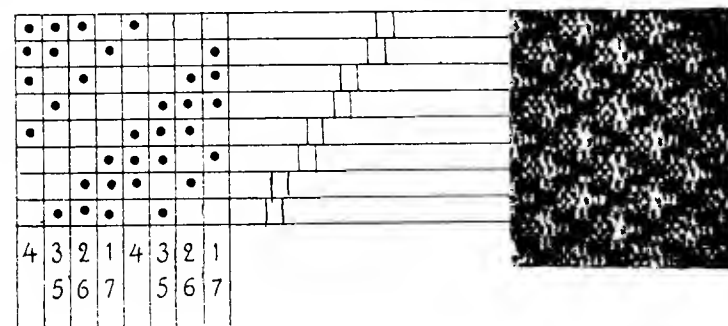


Fig. 385



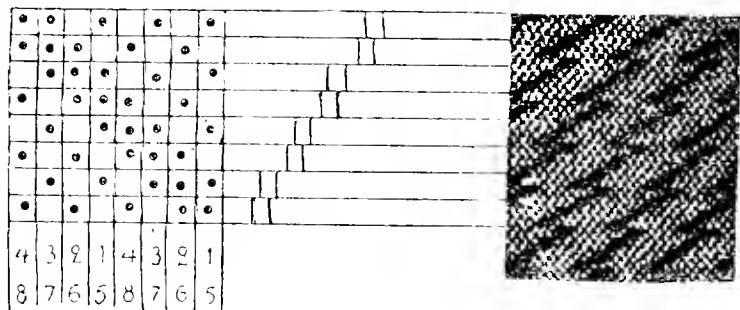


Fig. 386

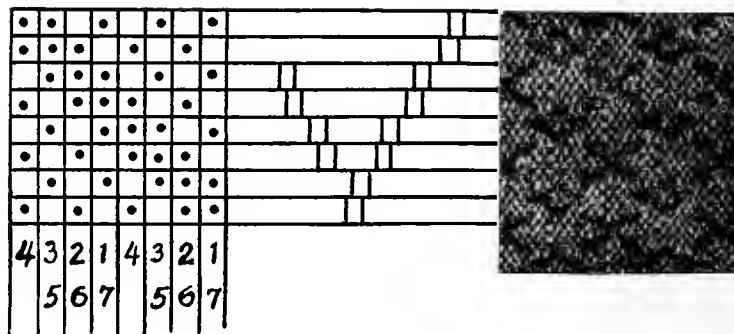


Fig. 389



Fig. 387

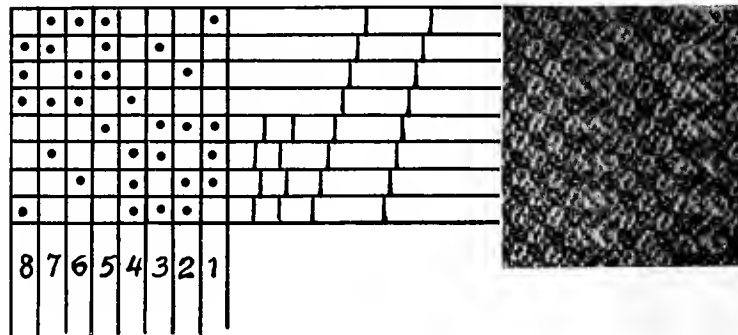


Fig. 390

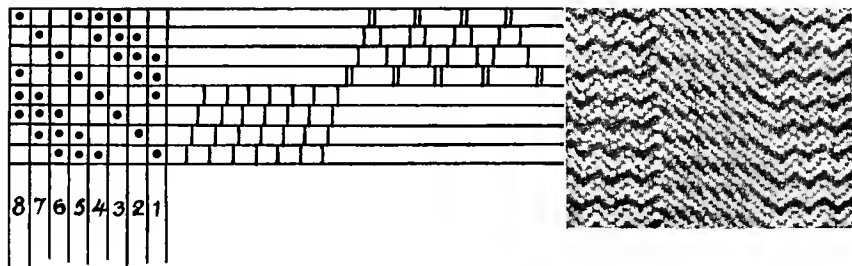


Fig. 388

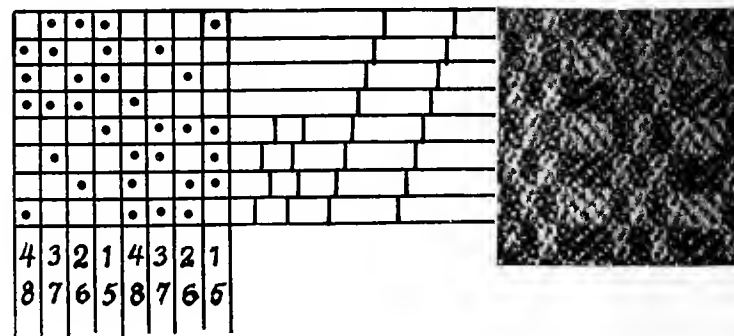


Fig. 391

CHAPTER VI

Damask Weave—Double Weave

Damask Weave

Figure 392 shows a most interesting ten-harness damask weave which may be used in weaving napkins and tablecloths. The draft is written just as the Norwegians write it. There will be little or no difficulty in accomplishing the weave after the threading and treadling are understood.

It has already been stated that each horizontal line means a pair of heddle sticks. The draft shows that there are ten, divided into two sections or groups, marked I and II. The first group consists of the first five harnesses and the second group of the second five.

The threading is indicated by the slanting lines which cross the horizontal parallel lines. Each horizontal line crossed by a slanting line means a thread.

The first thread passes through the eye of the first heddle on the first heddle sticks. Each thread is taken in its regular order, passing through the eye of the first heddle on each pair of heddle sticks from the first through the tenth.

The draft indicates that this order is again

repeated. The threading now changes and the heddles on the first five harnesses only are used. This is continued for nine repeats as shown by the

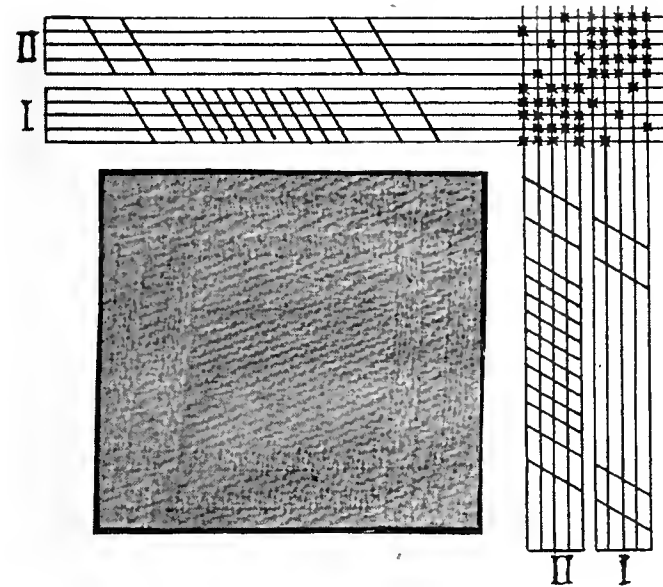


Fig. 392

nine slanting lines. The third change is the same as the first, which threads from the first through the tenth.

The entire pattern is made up by repeating the draft shown in Fig. 392.

Threading the Reed

Each thread passes through the eye of a heddle.

In threading the reed, three threads may be drawn through each dent. Sometimes when a large number of threads is used to the inch, four threads are drawn through a dent. This makes it possible to use a coarser reed, thus simplifying the threading.

"Tie-Up"

It will be observed that each vertical line indicates a treadle. These treadles are divided into two groups, I and II.

Group I operates the first five, and Group II operates the second five.

The treadles are tied as indicated by the stars. The double set of lambs should be used. See Fig. 220.

The treadling is done by pressing down the tenth treadle, then the ninth, and so on through the ten. This order is again repeated. From here only the second group treadles are pressed down in their regular order nine times. From here the treadling goes back to the tenth through the ten twice. This order of treadling is continued throughout the entire weaving. The weaver soon learns to repeat any order of treadling as many times as is necessary to produce the desired effect.

Ten-Harness "Tie-Up"

If the plan for "tie-up" suggested in Fig. 220 is not used, the device shown in Fig. 393 is easily constructed and used to work ten harnesses.

The lowest pulley controls the two middle harnesses, the one above controls the two har-

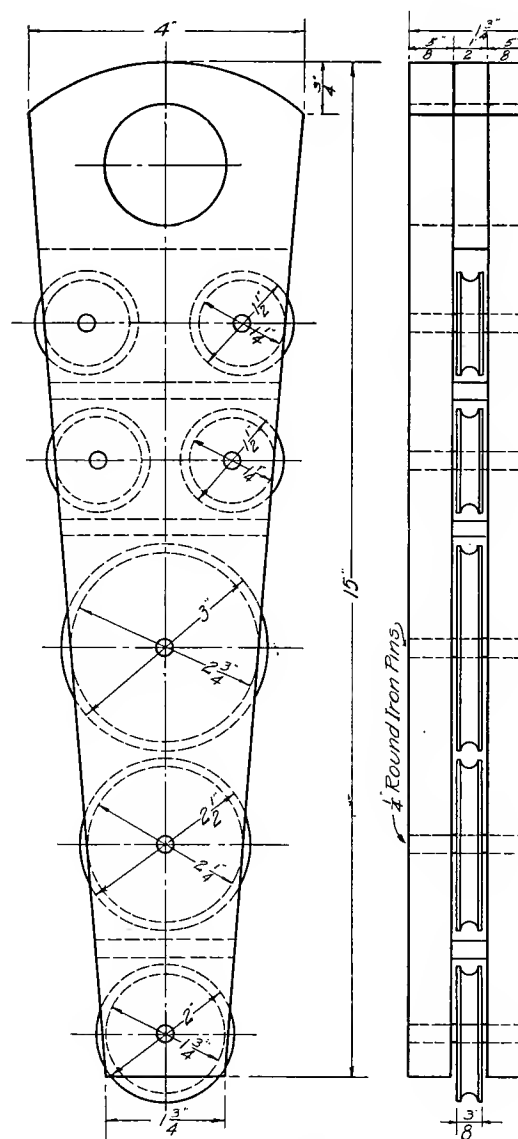


Fig. 393

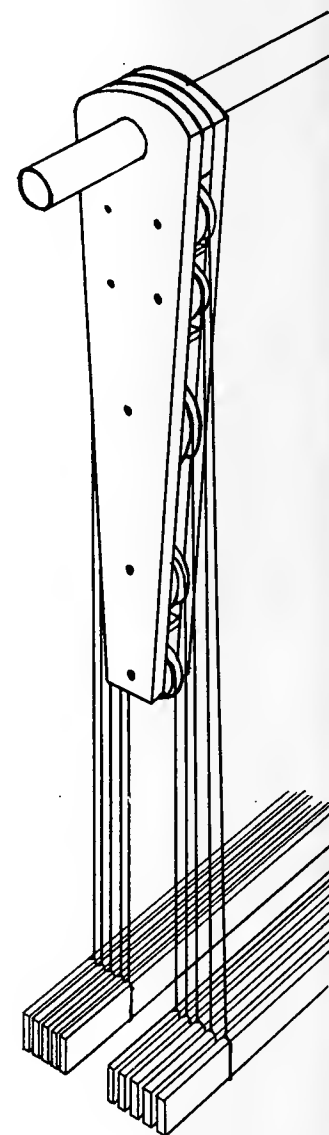
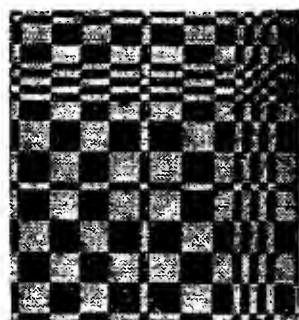
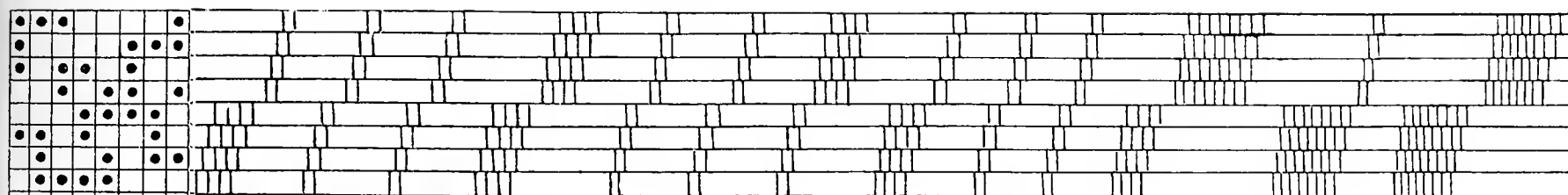


Fig. 394

Border.



Body.

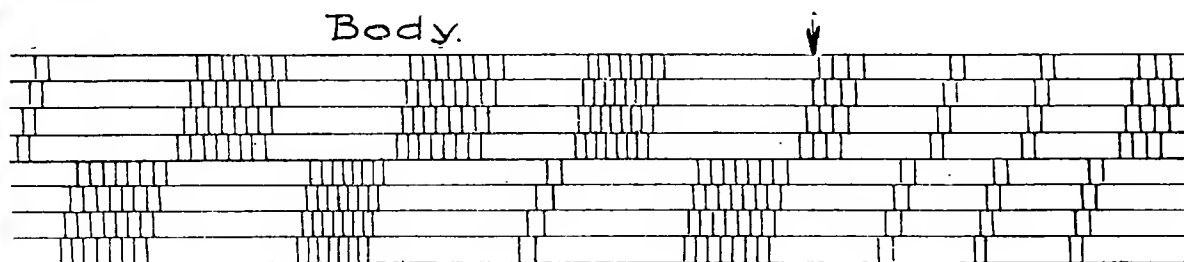


Fig. 395—Eight-Harness Damask Weave

nesses, one at each side of the two center ones. The third pulley controls two other harnesses in a similar way as just mentioned. In the case of two small pulleys the rope passes over the two, one end tied to one harness and the other to another. The two top pulleys control the first and last harnesses. No heddle horses are required.

The drawing shown in Fig. 394 shows the ropes tied to one end of the heddle sticks.

Figure 395 shows the draft for an eight-harness damask weave written in the Swedish way. In this draft the space between two lines represents a pair of heddle sticks.

The threading begins at the right and is read toward the left. When the first part is threaded, begin at the left of the second.

The arrow indicates the end of the border.

The center begins with the arrow and includes

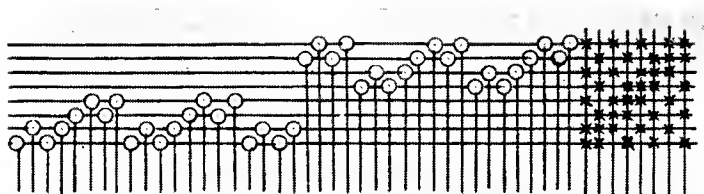


Fig. 398

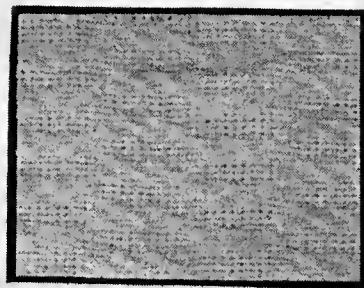
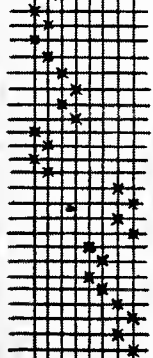
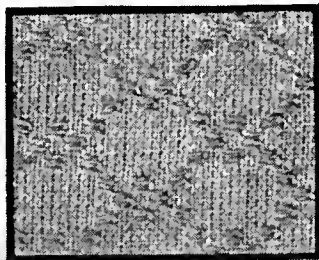
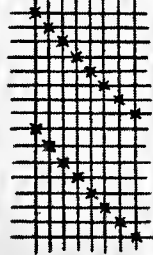


Fig. 399



The tie-up is indicated by the dots and the order of treading by the figures just below the dots. The "tie-up" may be with the one set of lambs or with the double set.

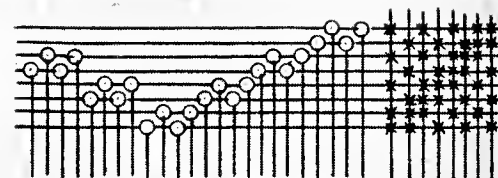


Fig. 400

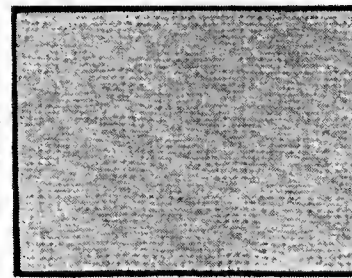
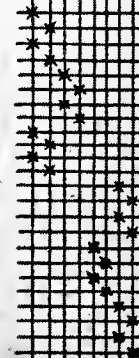
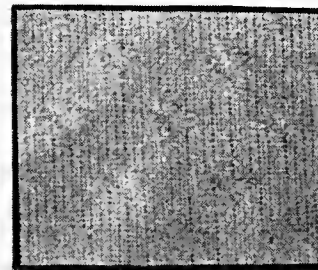
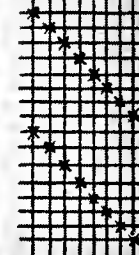


Fig. 401



The body part of the threading is repeated as many times as is necessary to give the desired width. The border also may be repeated several times. Figure 397 shows the threading for a ten-

harness damask weave. There are three arrangements shown. The tie-up and order of treading is given for the first one only. The weaver has, no doubt, learned by this time that the threading indicates the treading.

While Figs. 398, 399, 400, and 401 do not show the regular damask weave, they do show good examples of linen toweling and even good examples of materials that might be used in upholstery. The threading and "tie-up" for Fig. 398 and Fig. 399 are the same. The difference in pattern is brought out by a difference in the order of treading.

The stars on the vertical lines indicate the order of treading.

The threading and "tie-up" for Fig. 400 and Fig. 401 are the same. The difference in pattern is brought out by a difference in treading.

Figure 402 shows a very good diagonal weave in eight harnesses. While this draft is not good for toweling, etc., it is exceptionally good for coats, suiting, etc. The threading, "tie-up" and treading are all read from Fig. 402.

Figure 403 is a most excellent draft for linens. It is not a damask weave but very satisfactory when used in towels. Threading, tie-up, and treading are all read from the draft.

Fig. 402

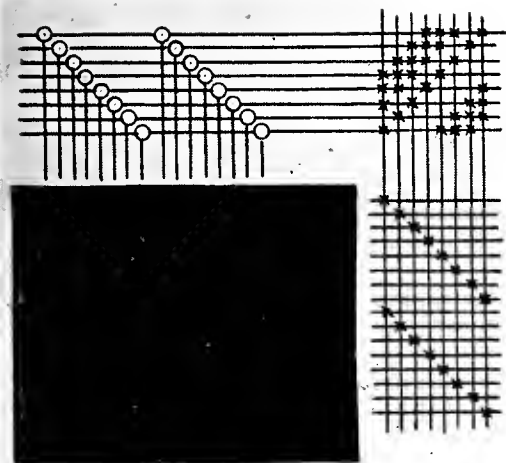
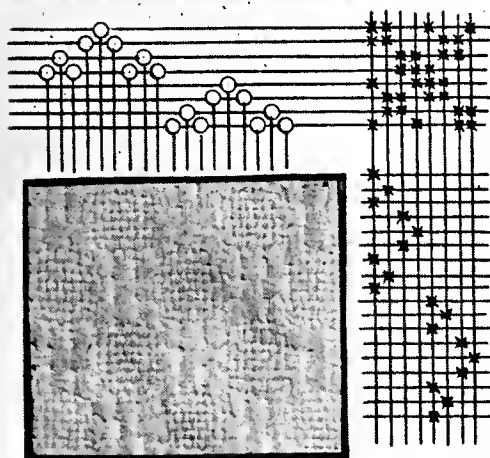


Fig. 403



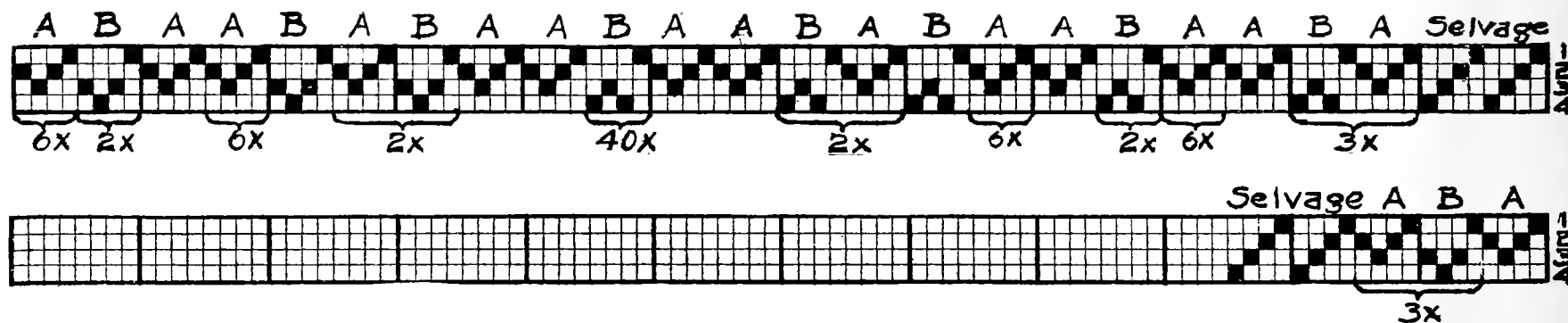


Fig. 404—Table Mat. Draft of Pattern

Table Mat

Figure 405 shows a table mat woven of No. 3 mercerized cotton warped in two colors. The draft shown in Fig. 404 indicates only two changes in the grouping of the threads. The colors used are green and golden brown. The selvage is of green. The first group of four threads, marked "A," is of golden brown.

The next four threads, marked "B," are green.

This is repeated three times, first A and then B.

It will be observed that the threads run in groups of four, A always being of golden brown and B of green.

Figure 405 requires 408 threads of two colors to be warped as above described, a number 20 reed, one pattern thread to a dent and two selvage threads to a dent of the first four and the last four dents of the draft.

The wool is the same material as the warp, a No. 3 mercerized cotton. The binder must be a much finer thread and of a different color. For the above colors, an orange binder works in very harmoniously.

The pattern lambs are tied in the following order:

1 and 2 to the first treadle.

3 and 2 to the second treadle.

1 and 4 to the third treadle.

3 and 4 to the fourth treadle.

The plain weave is done by tying lambs 1 and 3 to the right middle treadle, and 2 and 4 to the left middle treadle.

Figure 405, showing the finished mat, will give the weaver an idea of the way in which the treadles are operated to produce the design as given. The vertical bands are unchangeable. The horizontal

bands may be made any width by repeating 1-2 and 3-2, always using the binder after each pattern thread.

The other combinations are 1-4 and 3-4.

The wool is all of the same color.

It is the way the warping is done and the treading that makes the pattern.

The table mat has the effect of double weaving done with four harnesses. It is really a six-harness pattern reduced to four. A little experimenting will suggest a very great variety of combinations of stripes and squares which the operator may work out. The combination of threading may be varied so as to produce most interesting patterns.

Rug Weaving in Wool

Figure 406 shows another kind of double weave. The weave in Fig. 405 requires a binder, while the finished rug shown in Fig. 406 does not require a binder of any kind.

Figure 407 shows the draft.

The draft requires 240 threads. This allows for six selvage threads at the beginning and the end. Three selvage threads are drawn through the eye of a heddle at one time. Only two heddles are used for the selvage. In threading the selvage through the reed, draw three threads through each of the two dents. The warp is of ordinary four-ply carpet warp.

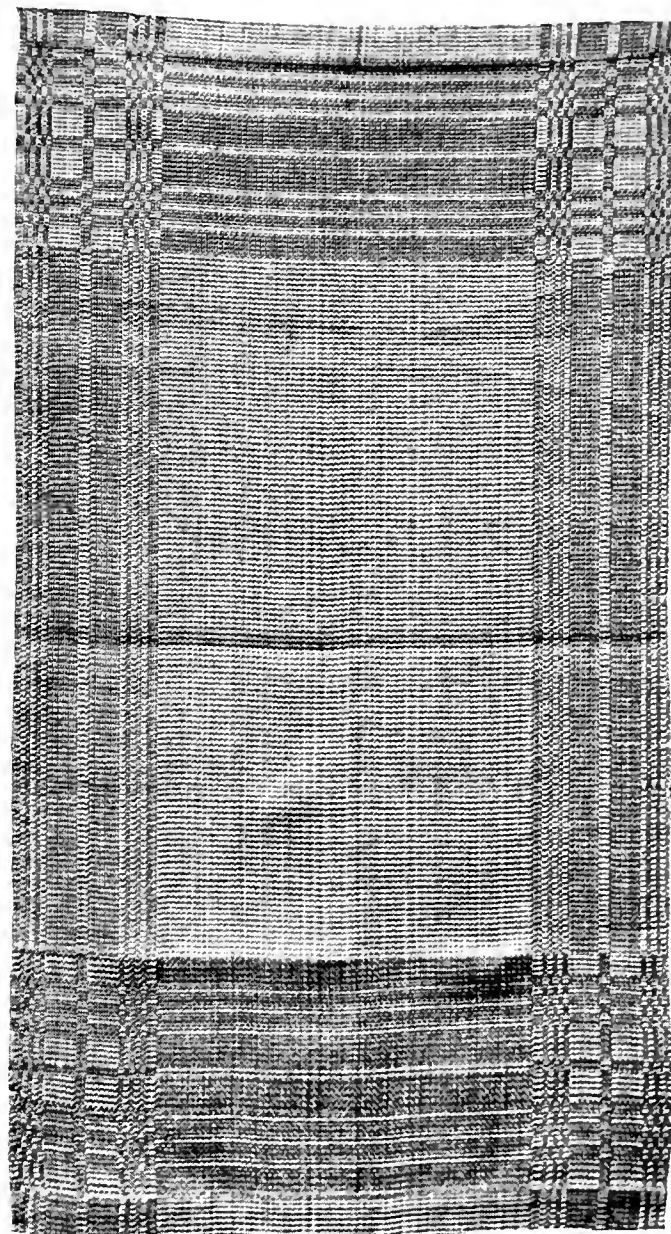


Fig. 405—Finished Mat

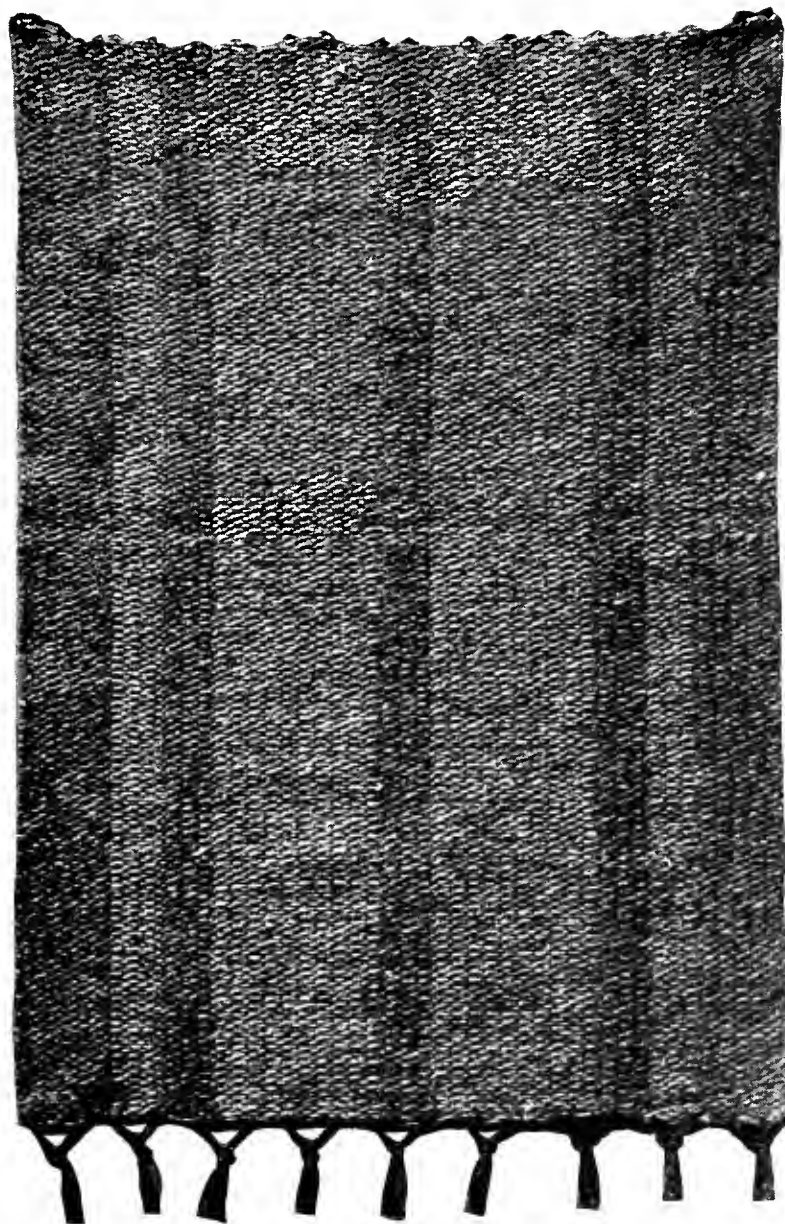


Fig. 406—Finished Rug

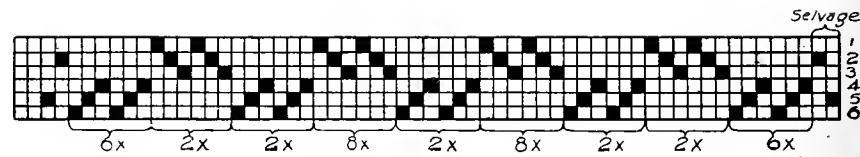


Fig. 407—Draft for Rug

The threading is done as shown in the draft, care being taken to repeat the number of times as indicated.

There are about seven threads to the inch.

Since the No. 15 reed is already in stock it may be used for the rug at hand, a thread being drawn through every other dent of the reed.

The draft shows that there are six harnesses. It requires but four treadles to operate the six harnesses, which are tied in the following way:

Lambs 2, 3 and 4 are tied to the first treadle.

Lambs 3, 4 and 5 are tied to the second treadle.

Lambs 1, 3 and 5 are tied to the third treadle.

Lambs 2, 4 and 6 are tied to the fourth treadle.

The double "tie-up" suggested in Fig. 220 may be used to advantage in weaving this particular pattern.

To produce the pattern shown in Fig. 406, two shuttles are used, one with a bobbin of white wool and one with a bobbin of blue wool. The wool used is similar to that used in kindergarten weaving. It is a kind of carpet yarn. It is almost as heavy as cotton roving.

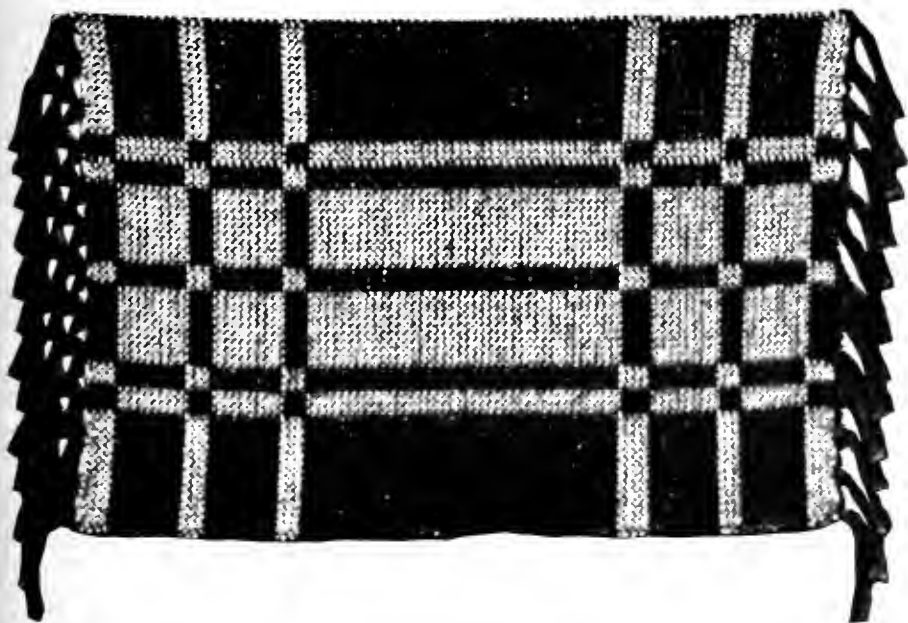


Fig. 408

Operation of Treadles

Treadle four is pressed down and the shuttle containing the blue is passed through the shed. Treadle one is next pressed down and the white thread is passed through the shed.

Treadle two is next pressed down and the blue used. Treadle three is pressed down and the white passed through the shed. This order of treading is continued throughout the weaving of the entire rug shown in Fig. 406.

Figure 408 shows the same threading, but a different order of treading. Instead of using blue

and white for the woof, tan and brown are used. The weaving is started in the same way as in Fig. 406.

After the band of one color is as wide as is desired, the opposite color is made to reverse. This change is brought about by passing the same color through the shed twice. The order of treading is exactly the same.

Sea Shell Pattern

The draft shown in Fig. 409 is that of a six-harness loom.

The draft shows that ten treadles are required to produce the pattern shown in Fig. 410.

It requires 148 threads for one repeat.

The warp is of a two-ply No. 30 Egyptian twine, and the woof is of a No. 5 mercerized cotton. There are thirty threads to the inch drawn through the dents of a No. 15 reed, two threads to the dent.

The lambs are tied to the lower heddle sticks.

The lambs are tied to the treadles in the following order:

Lambs 1 and 3 are tied to the first treadle.

Lambs 2 and 3 are tied to the second treadle.

Lambs 1 and 4 are tied to the third treadle.

Lambs 2 and 4 are tied to the fourth treadle.

Lambs 1 and 5 are tied to the fifth treadle.

Lambs 2 and 5 are tied to the sixth treadle.

Lambs 1 and 6 are tied to the seventh treadle.

Lambs 2 and 6 are tied to the eighth treadle.

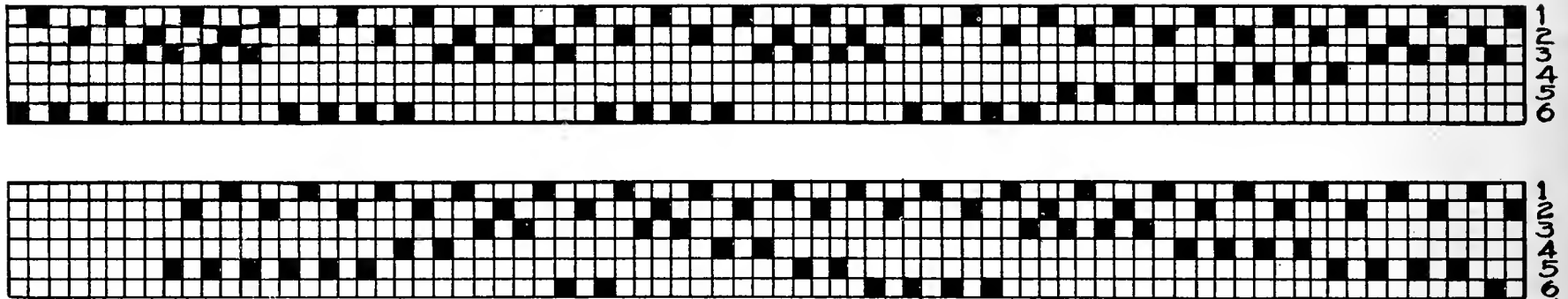


Fig. 409—Sea Shell. Draft of Pattern

The plain weave is done by tying:

Lambs 1 and 2 to the right middle treadle.

Lambs 3, 4, 5 and 6 to the left middle treadle.

Figure 410 shows the finished Sea Shell. It is a close weave and may be used for window side drapes, pillow tops, table runners, and because of the closeness of the weave it may very successfully be used in upholstering.

It is perhaps the most difficult to weave because of the six harnesses and ten treadles. If the double "tie-up" suggested in Fig. 220 is used, there will be no difficulty in securing a good shed.

Any shade of No. 5 mercerized cotton may be used.

The draft itself indicates the order of treading. It will be remembered that each dark square indicates a woof thread. In the first combination of threads 1 and 3 are given. This means that the treadle controlling harnesses 1 and 3 is pressed down

twice for the pattern threads with a binder after each pattern thread. Since this method of expressing the reading of a draft has previously been most carefully explained it will not be necessary to again go into detail at this time.

Double Weaving

Double weaving is one of the most interesting phases of the art of weaving. It is a branch of the work that amateur weavers know the least about. It is difficult to understand just how the weavers of many years ago controlled the number of harnesses necessary to produce the seemingly complicated patterns found in old counterpanes possessed by many of the older settlers.

The plan of this manual is to give only a few of the more simple suggestions in double weave.

In most of our old Colonial double weaves, the warp is of both cotton and wool. In short, there are

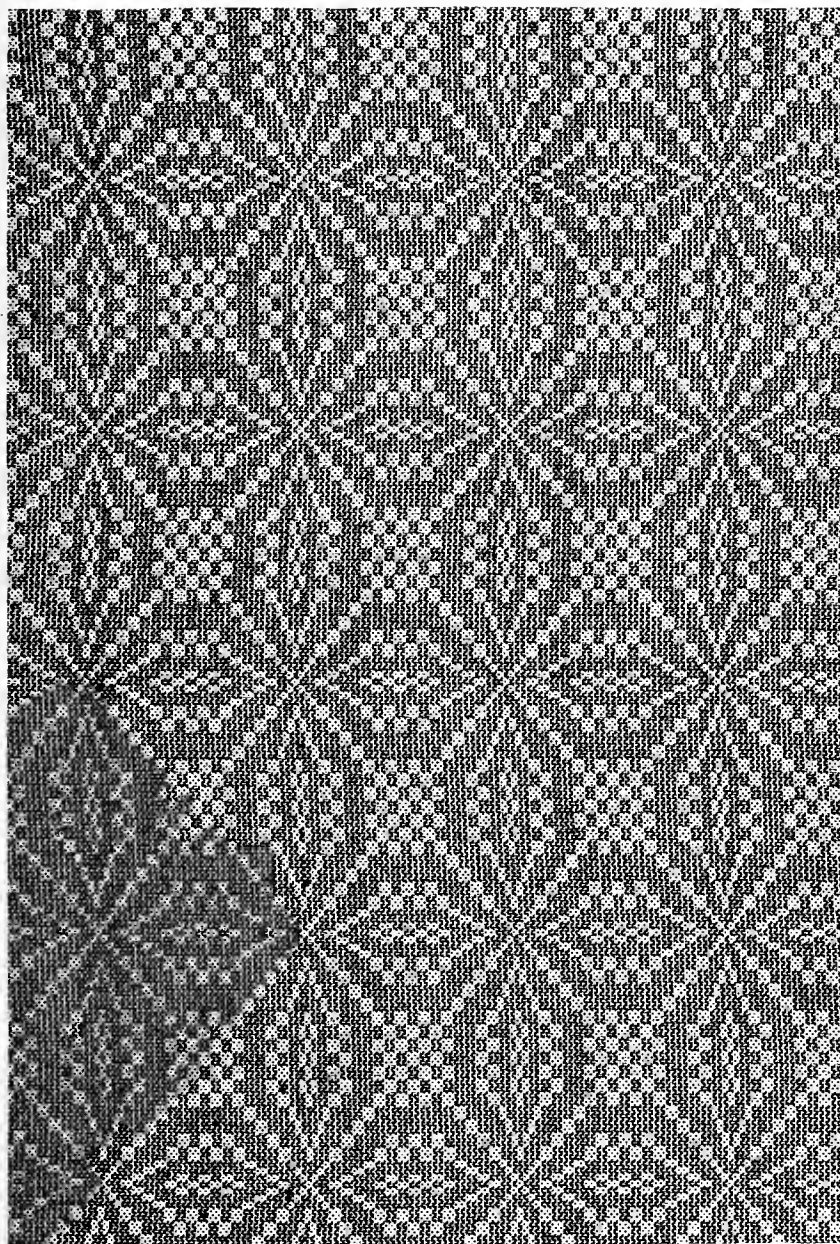


Fig. 410—Sea Shell

two distinct warps, the one of wool being placed on one warp beam and the one of cotton placed on another beam.

The beams may be placed as shown in Fig. 411. An extra pair of warp beam brackets is placed below the pair already on the loom. Pegs are placed just above the ends of the lower beam to prevent it from being drawn upward when the warp is tightened. See A, Fig. 411.

The two beams are absolutely necessary when the warp is of both wool and cotton because of the fact that wool stretches so much more than cotton. With the warp on separate beams the wool may be tightened to meet the tension of the white warp.

The blue (if blue is used) wool warp is placed on the upper beam and the white cotton on the lower beam. Separate lease rods are used and the ends of the white warp are carried right over the blue warp beam.

Threading the Pattern

When threading the pattern every other thread must be blue, as is indicated in the draft, Fig. 412.

The pattern shown in Fig. 413 shows a simple, eight-harness double weave.

The draft is written in the Norwegian way and resembles that of the Damask weave. The harnesses are divided into two groups marked I and II.

The circle indicates a white thread and the dot

a blue one. Thread each, repeat as many times as is indicated by the figure below the brace.

Threading the Reed

Use a number 20 reed, drawing a blue and a white thread through each dent.

"Tie-Up"

The tie-up for this pattern is indicated by the stars on the vertical lines.

The double tie-up using the two sets of lambs, Fig. 220, is the best for double weaving.

Treadling

The light and heavy dots on the vertical lines indicate the order of treadling.

In weaving, two shuttles are required, one with a bobbin of blue wool and the other with a bobbin of white four-ply carpet warp. The first treadle to the right in group one is pressed down and a white thread passed through the shed. The second treadle is pressed down and a blue wool thread is passed through the shed. The third treadle is pressed and a white thread passes through. The fourth treadle is pressed and a blue thread passes through. The next treadle pressed down is the first again.

Follow the order shown in the draft.

The front border is woven by pressing down the treadles shown in the first sixteen changes just below the stars and indicated by the arrows.

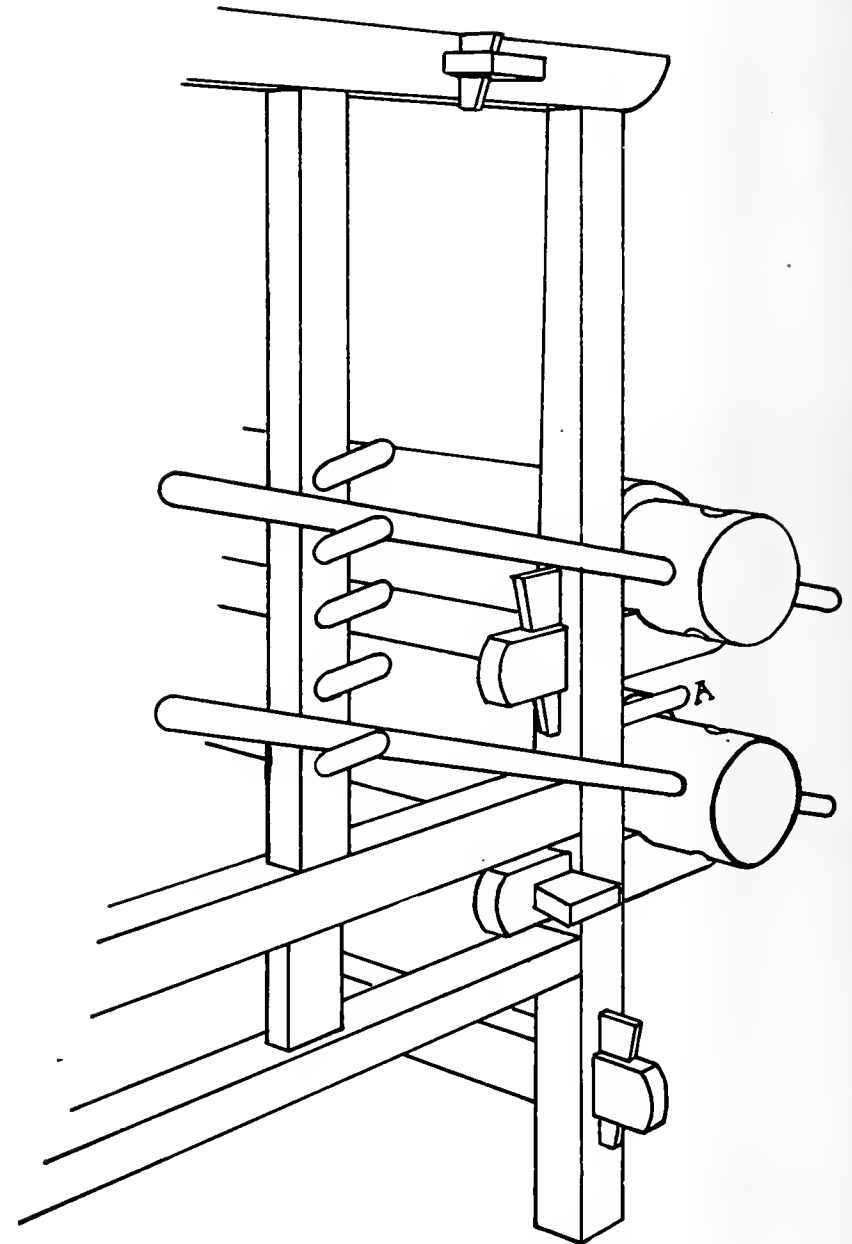


Fig. 411—Placing of Beams for Double Weaving

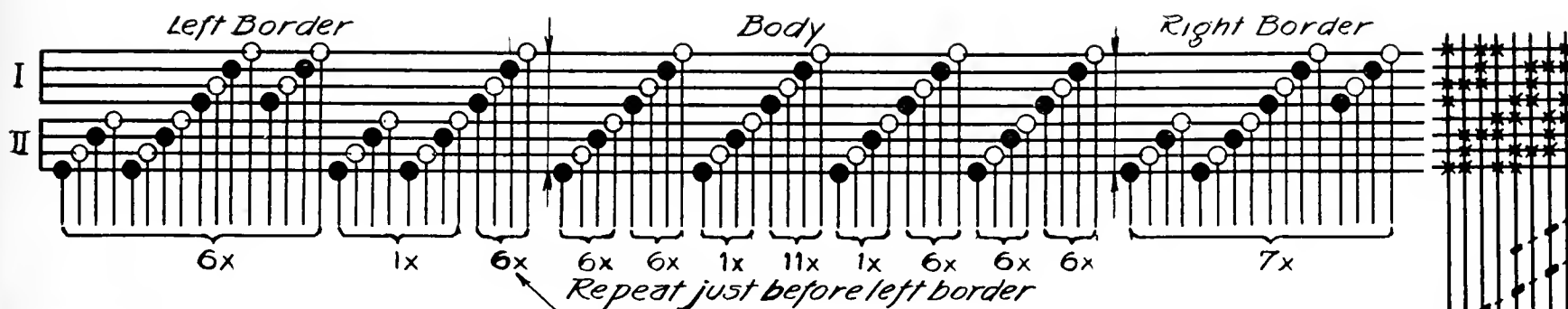


Fig. 412—Double Weave Draft.

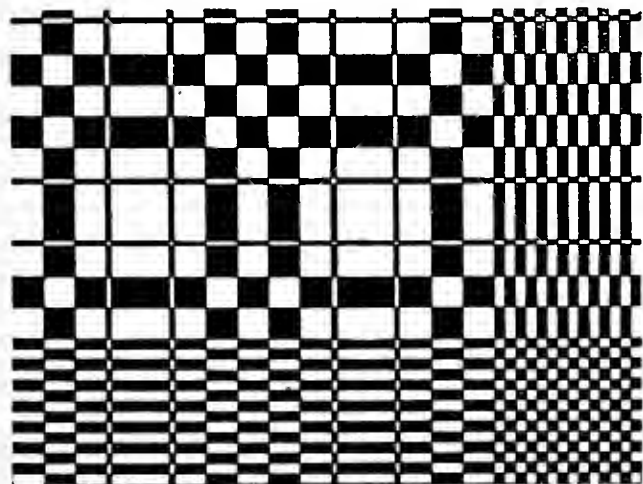


Fig. 413

The weaver must use his own judgment in the number of wool threads to use. Fig. 413 shows a drawing of what the *finished weaving* should be like.

If the warp is all of cotton, both blue and white, then one warp beam is sufficient, the warping being done so that every other thread is blue.

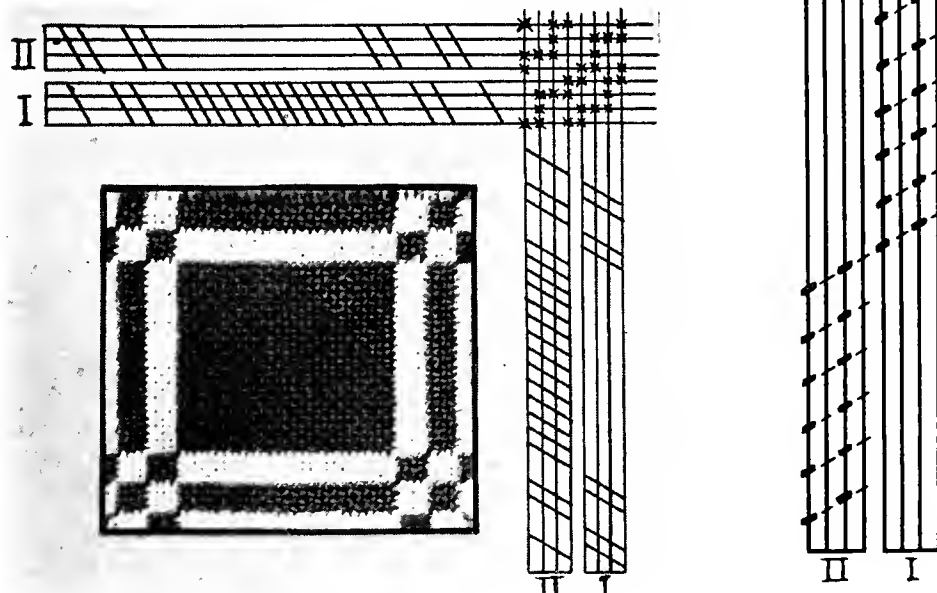


Fig. 414

Figure 414 shows the Danish way for writing a draft for double weaving. The threading resembles that of the Damask weave.

CHAPTER VII

Textiles and Wood

Applications to Furniture

Heretofore very little has been done in the combination of hand-woven textiles and wood, yet there is no combination of materials that gives such a large variety of artistic effects as this one. The different ways in which this material may be used, in combination with wood, are too numerous to mention; therefore, we shall take only those simple problems which are within the capabilities of even a sixth, seventh, or eighth-grade boy.

Foot Stool

The first problem that we suggest is that of a small foot stool, upholstered in hand-woven material. Fig. 415 shows the working drawing of this unique, but simple, little foot stool showing the wide possibilities for individual design. Here is a problem that a whole class may construct, and no two made alike. We have given a few suggestions as to how the design of the legs of the stool may be altered or enlarged upon. The size of the stool itself may be changed with pleasing results by making it longer, lower, or narrower, so that there are any number of

ways of changing the design of this stool without losing any of its artistic qualities. It is a most flexible problem.

After the stool is constructed, upholster it with a piece of hand-woven material. This may be either woven by the boy himself or by the girls in the weaving class of the school. Here again are more possibilities for making each piece more individual, since each piece of material may be of a different pattern, yet all may be woven from the same threading on the same loom.

This material might be used wherever upholstering is possible, on a great variety of household furniture with most pleasing and beautiful results. A little touch of hand-woven material gives to any article upon which it is used a most subtle appearance.

Figure 416 shows the completed stool made from the working drawing shown in Fig. 415. The design used for weaving the material used in upholstering this stool is one of the many possible ones of the Rose Path pattern.

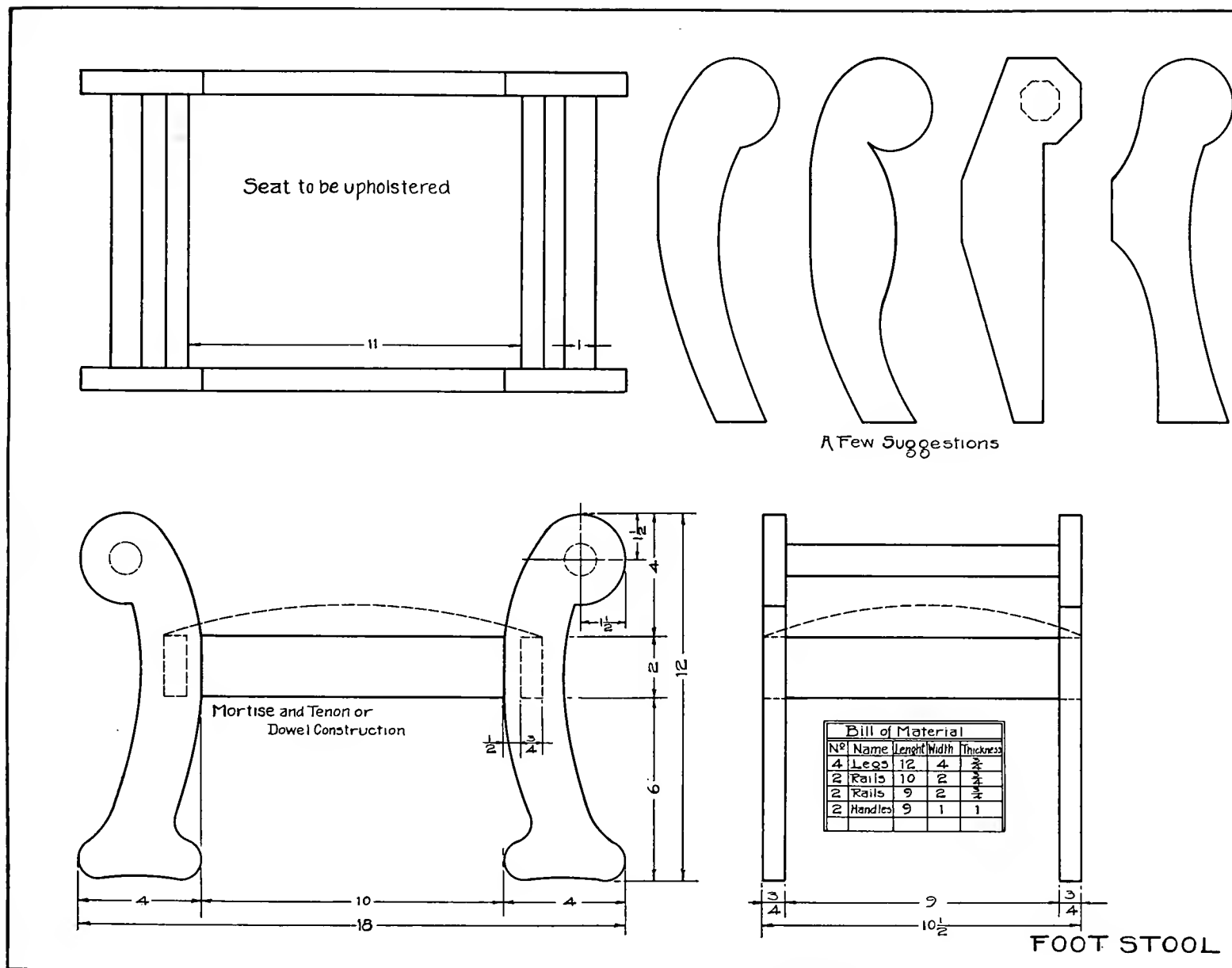


Fig. 415—Working Drawing of Upholstered Foot Stool



Fig. 416—Finished Foot Stool

Waste Basket

Figure 418 shows the working drawing of a very simple waste basket that any sixth-grade boy could build without much difficulty. The only difficulty is in boring the holes at the proper angle.

Two pieces of cloth are woven the length of two sides and the bottom. Hems are sewed at both ends so that when the dowel rods are placed through the hems and then put in place, the cloth will hold the basket together. It is necessary to have the cloth stretched very tightly in order to have the basket rigid.

Figure 417 shows the finished waste basket. The border around the top of the cloth is woven with the Rose Path pattern.

If the tapering of the sides of the waste basket seems too difficult, a straight sided sewing basket may be constructed as shown in Fig. 419. The construction is the same as for the waste basket. The design of the hand-woven cloth is another possibility of the Rose Path pattern.

Screens

There is no article of furniture in which hand-woven cloth may be used so effectively as in a screen. Fig. 420 shows the working drawing of a screen in which the panels are of hand-woven material.



Fig. 417—Finished Waste Basket

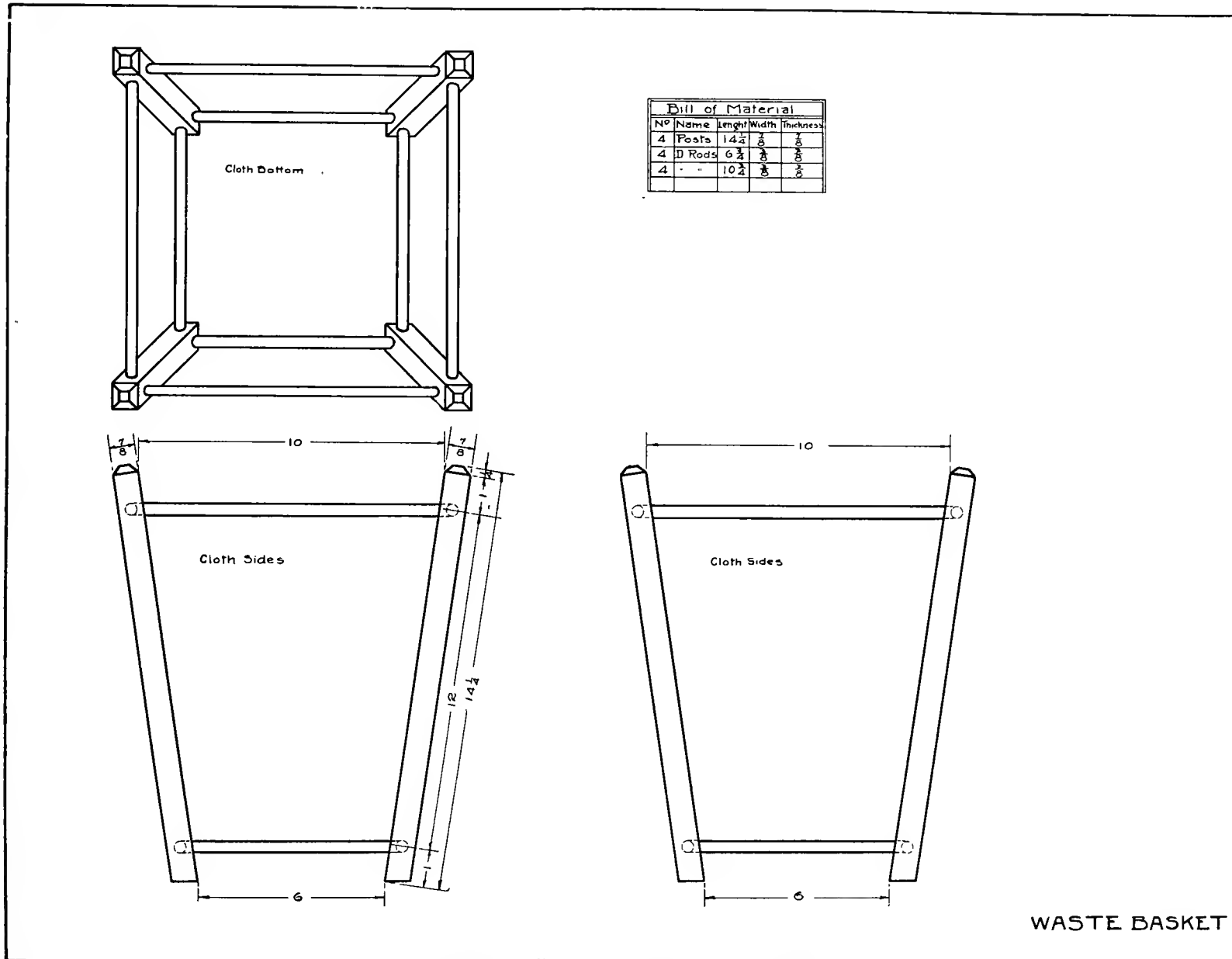


Fig. 418—Working Drawing of Waste Basket

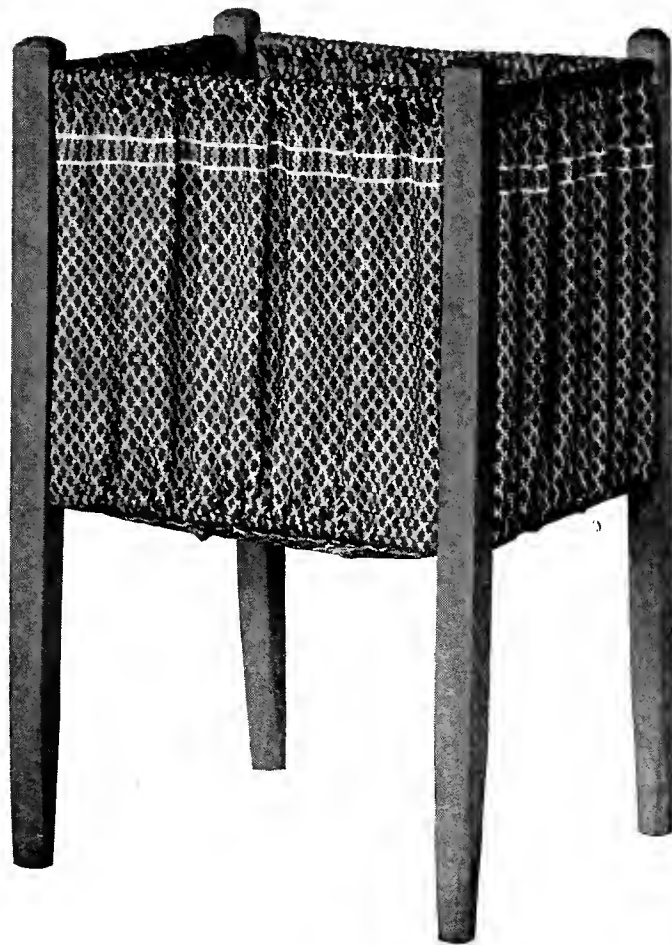


Fig. 419—Finished Sewing Basket

The inner sides of each frame are grooved the same as for a wooden panel; a key is made to fit loosely into this groove. The cloth is placed over the groove, the key placed on top the cloth over the groove, and then forced down into the groove. This makes a very good way of fastening the cloth to the

frames. A few finishing nails may be driven through the key into the frame to hold the key in place.

That this combination makes a beautiful as well as useful piece of furniture may be seen from the photograph shown in Fig. 421. The cloth is woven from the Orange Peel pattern, a border being woven at the top and bottom to break up the space.

Though the construction of this screen is simple, it should be made as a group problem rather than an individual one; the boys to make the frame, and the girls to weave the cloth.

Figure 422 shows the working drawing of another very attractive screen of different construction from the first one mentioned. In this screen build the inside frames as shown, of any lumber, then cover both front and back with the cloth, tacking it along the outside edges of the frames. Make the grooved strips as shown, and tack them on the outside edges of the frame, covering up the edges upon which the cloth has been tacked. This gives a very neat and effective finish to the screen, since all of the frame that shows is the little grooved moulding on the outside edges.

Figure 423 shows how attractive this kind of a screen can be made to look by just using strips of hand-woven cloth, embroidered with rope silk. Observe how beautifully the panels are broken by skilful designing.

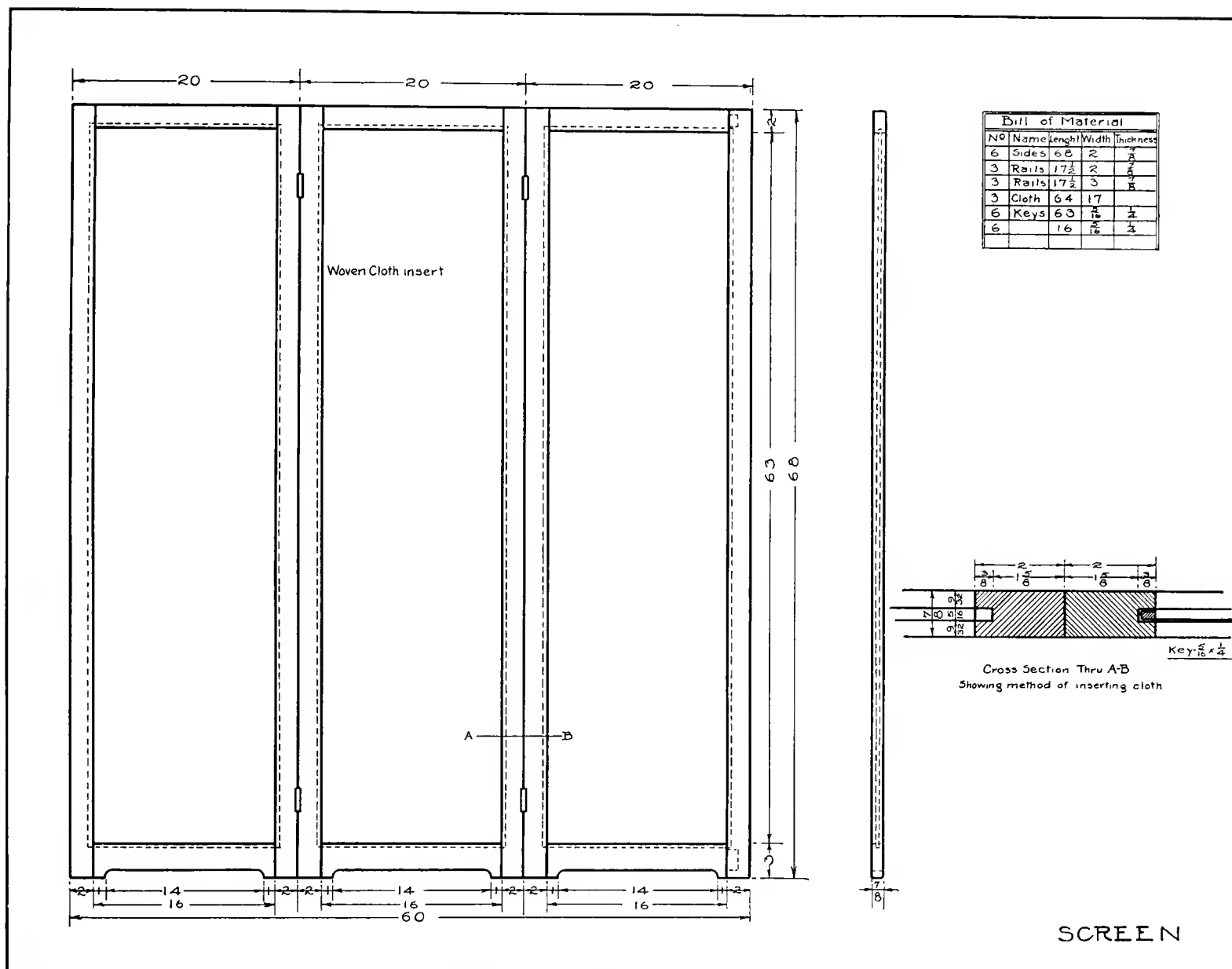


Fig. 420—Working Drawing of Screen

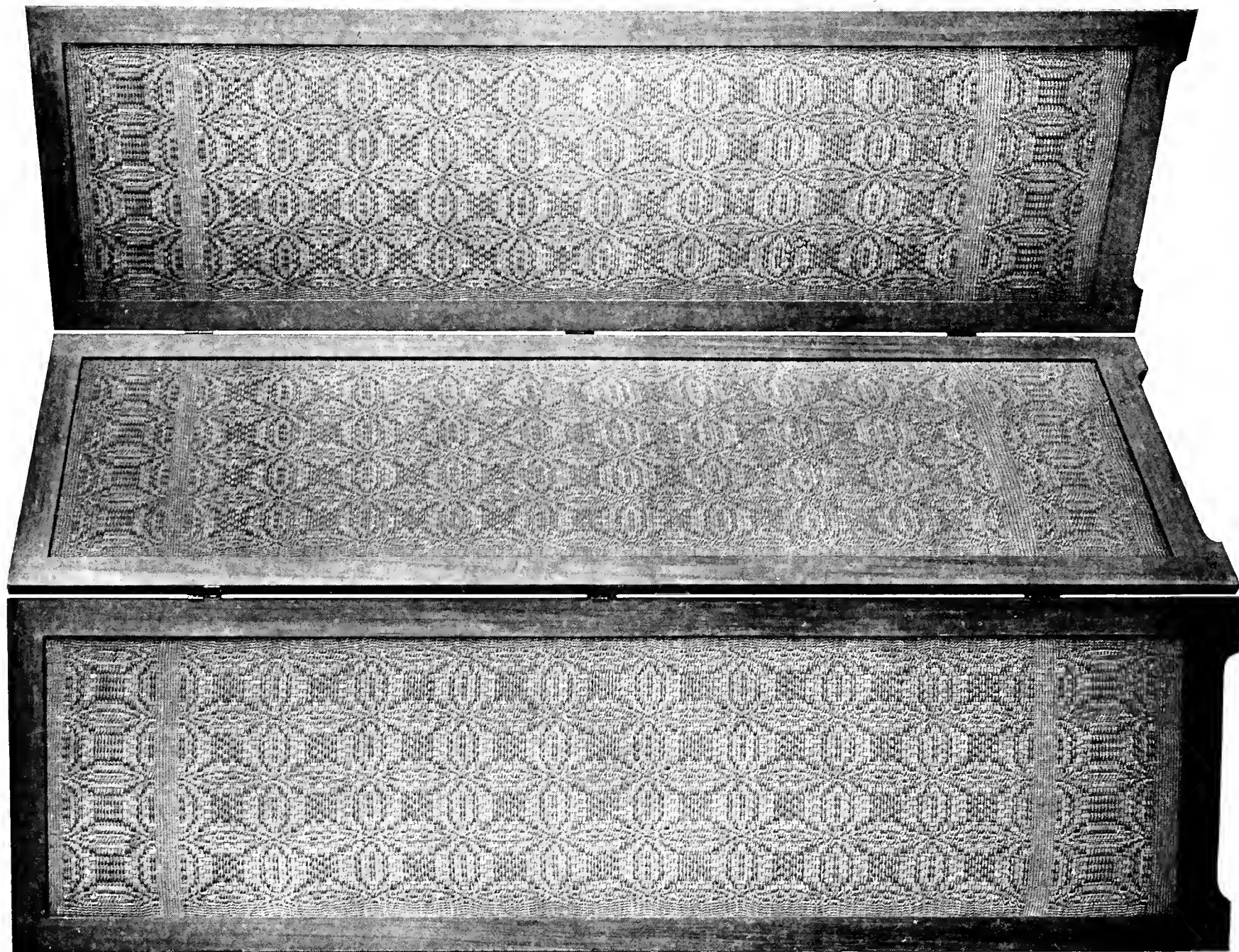


Fig. 421—Finished Screen

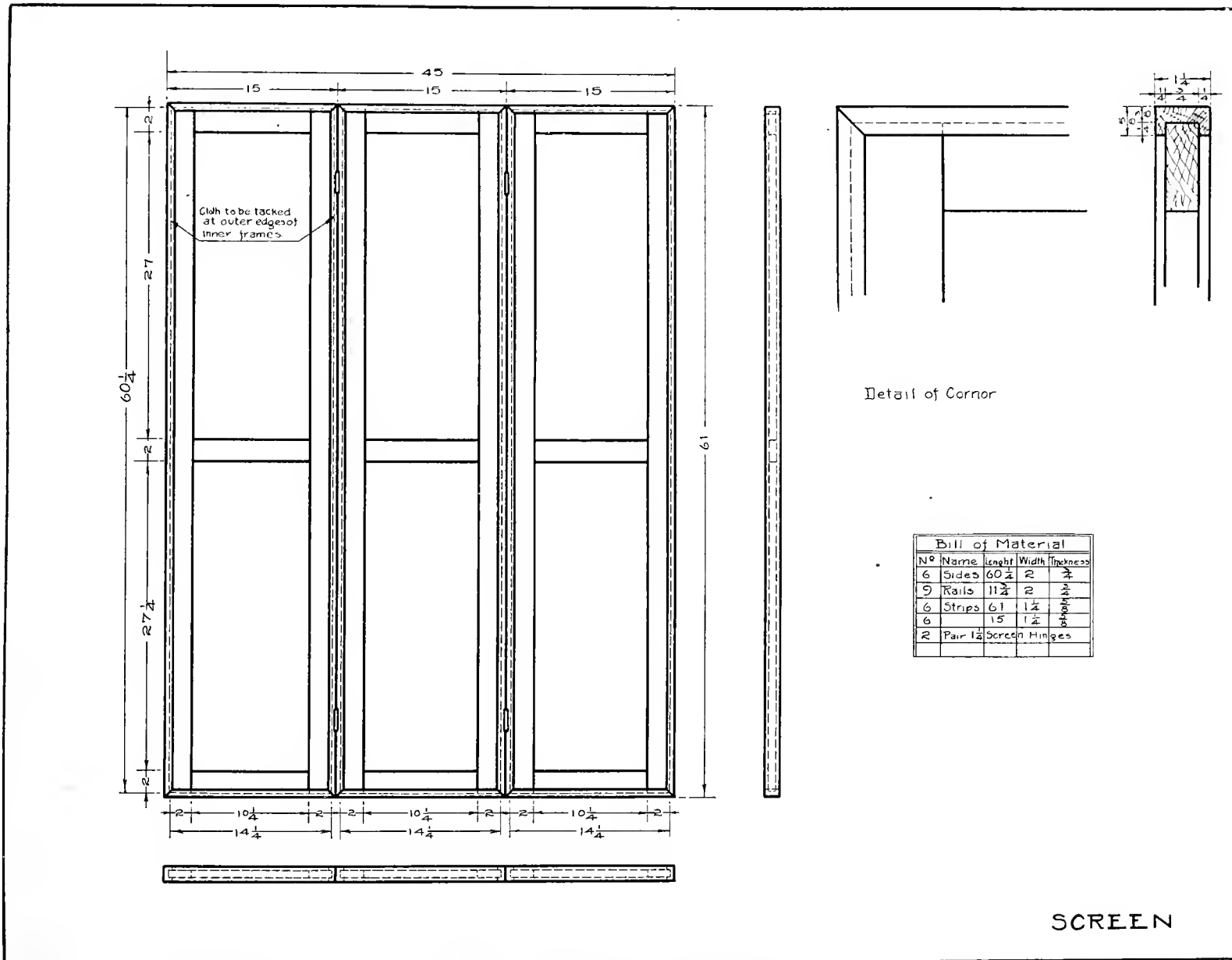


Fig. 422—Working Drawing of Screen

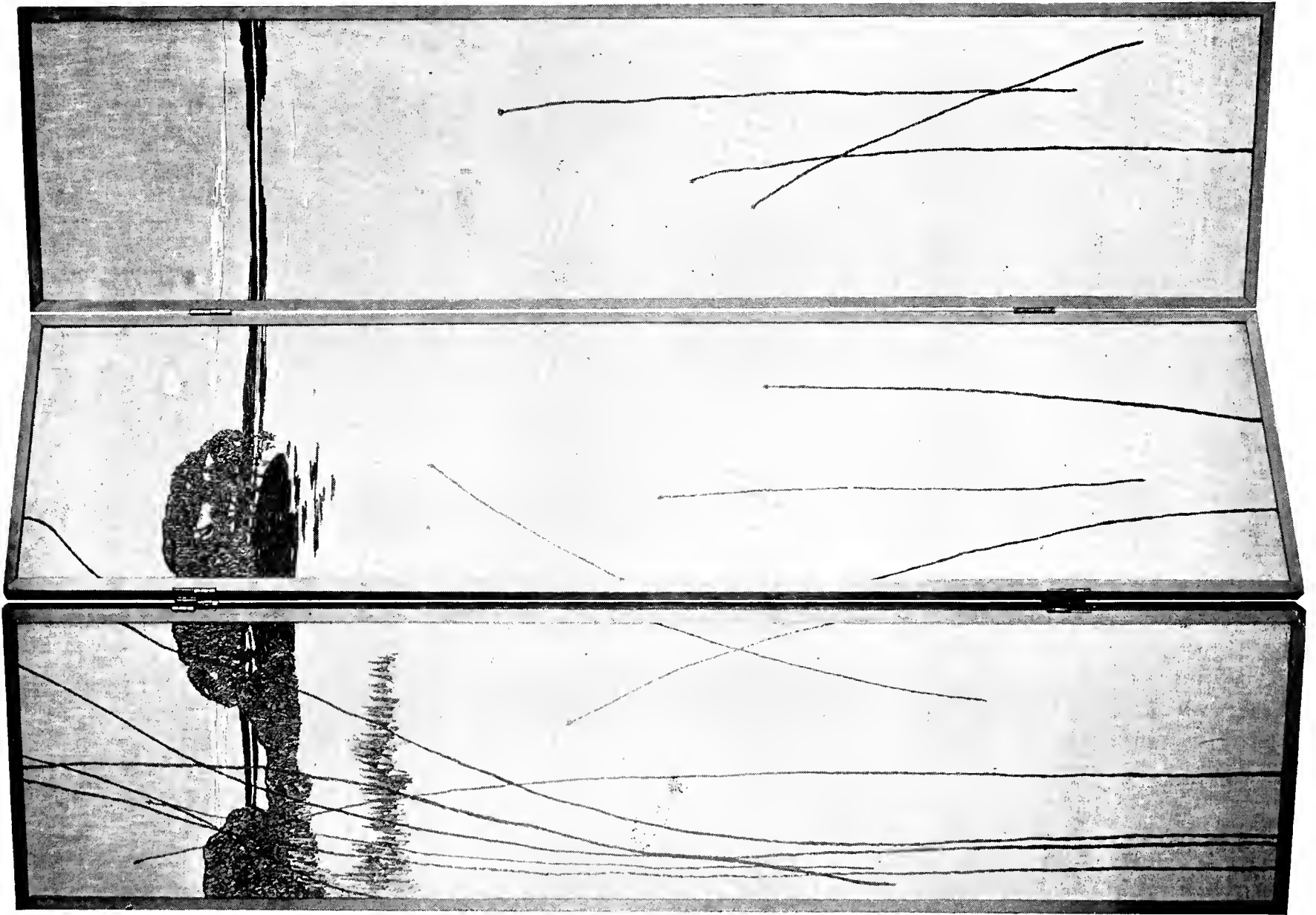


Fig. 423—Finished Screen

CHAPTER VIII

The Design and Construction of Looms

Danish Loom

The following cuts show the working drawings for both the Danish and Swedish looms. If light work only is desired then the Danish loom shown in Fig. 424 is the loom to construct. Fig. 425 shows the front working drawing. Fig. 426 shows the side and Fig. 427 shows the detail drawings of the various parts.

Swedish Loom

Fig. 428 shows the completed Swedish loom. If space is available this is the loom to have. On this loom may be woven very fine articles as well as the Colonial rugs. On the Danish loom only the lighter work can be successfully woven. Fig. 429 shows the working drawing for the front of Swedish loom. Fig. 430 shows the side, and Fig. 431 shows the detail drawings of the beater, warp beam, heddle sticks and other movable parts.

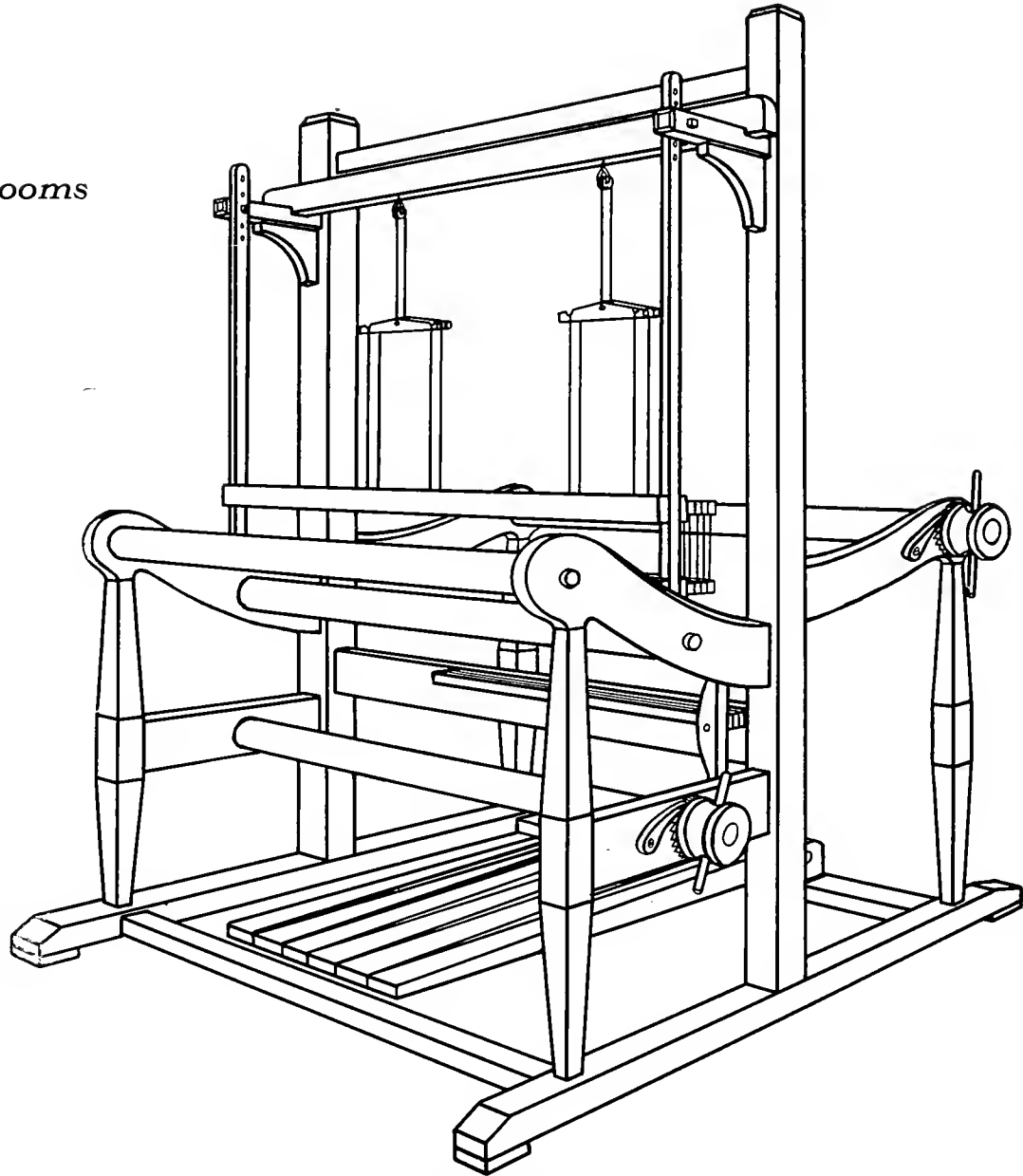


Fig. 424—Sketch of Danish Loom

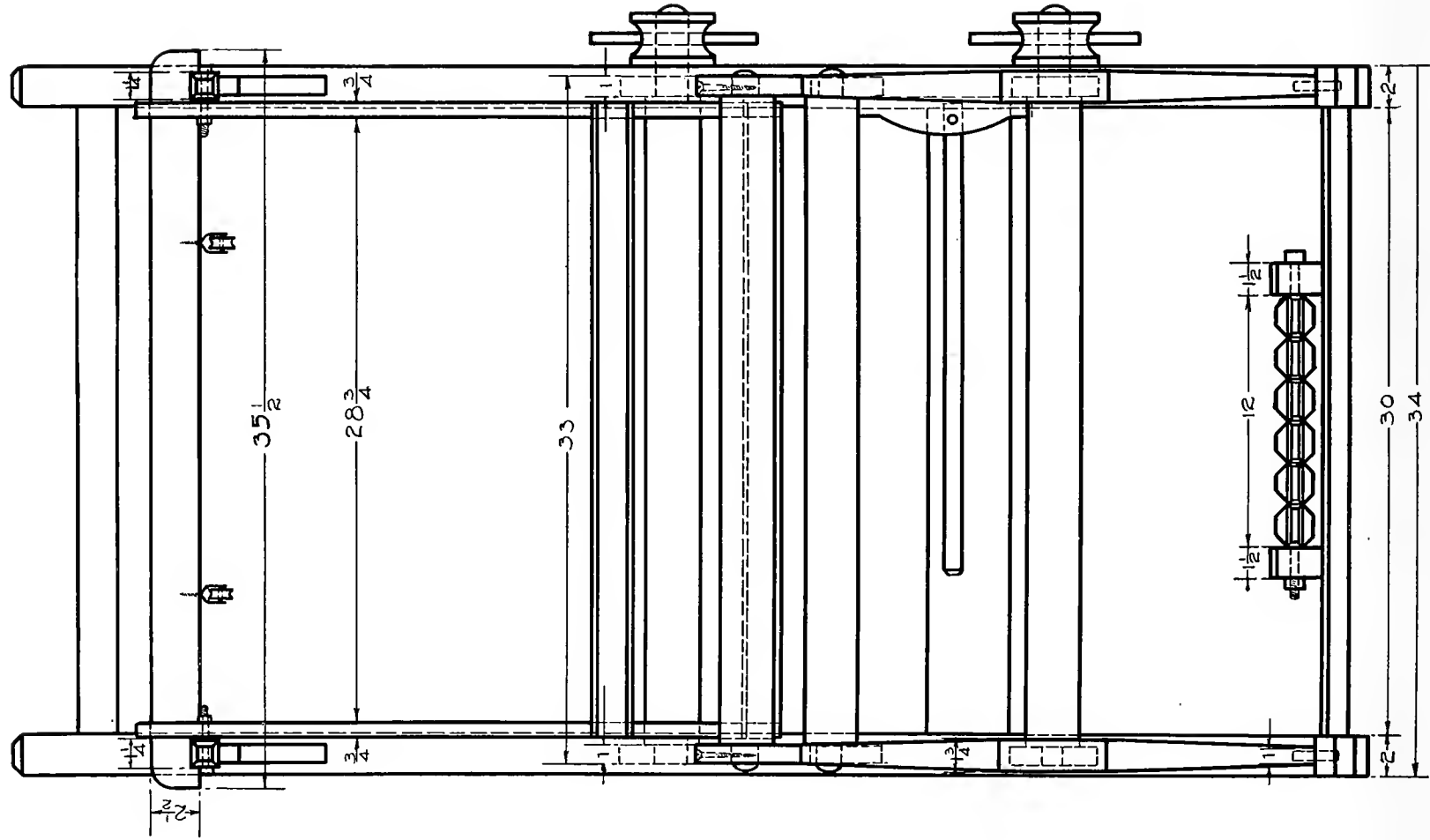
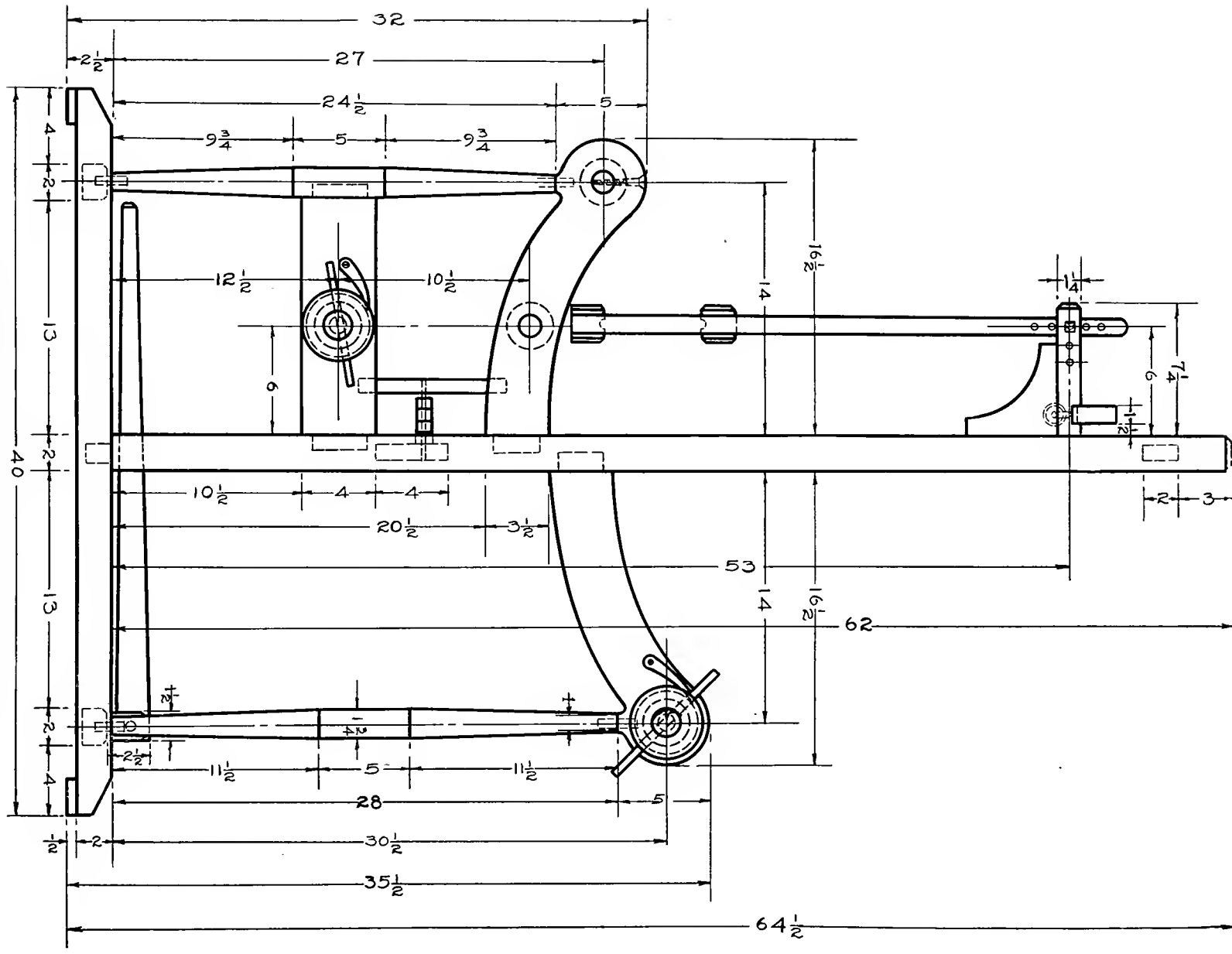


Fig. 425—Working Drawing of Loom—Front View

Fig. 426—Working Drawing of Loom—Side View



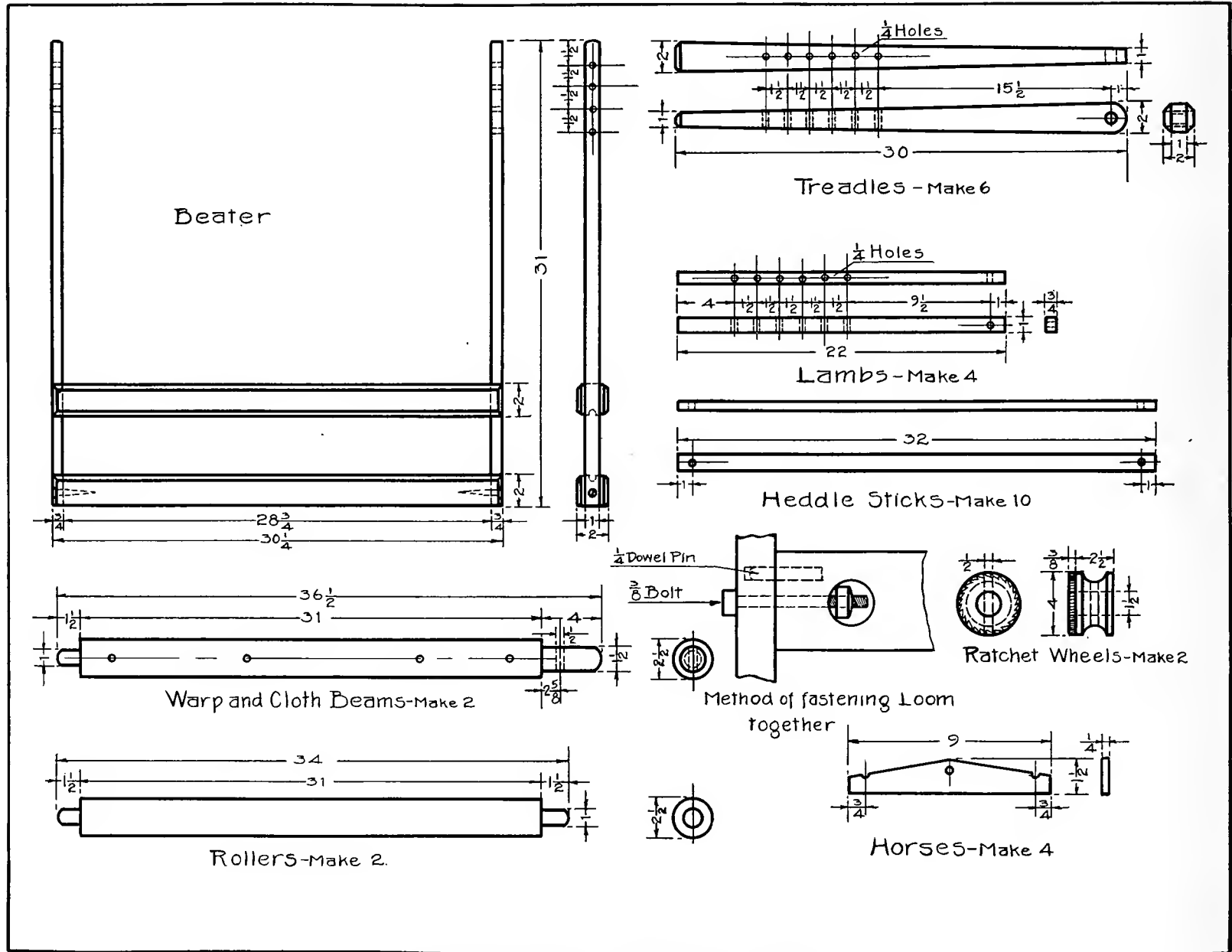


Fig. 427—Working Drawing of Loom—Details

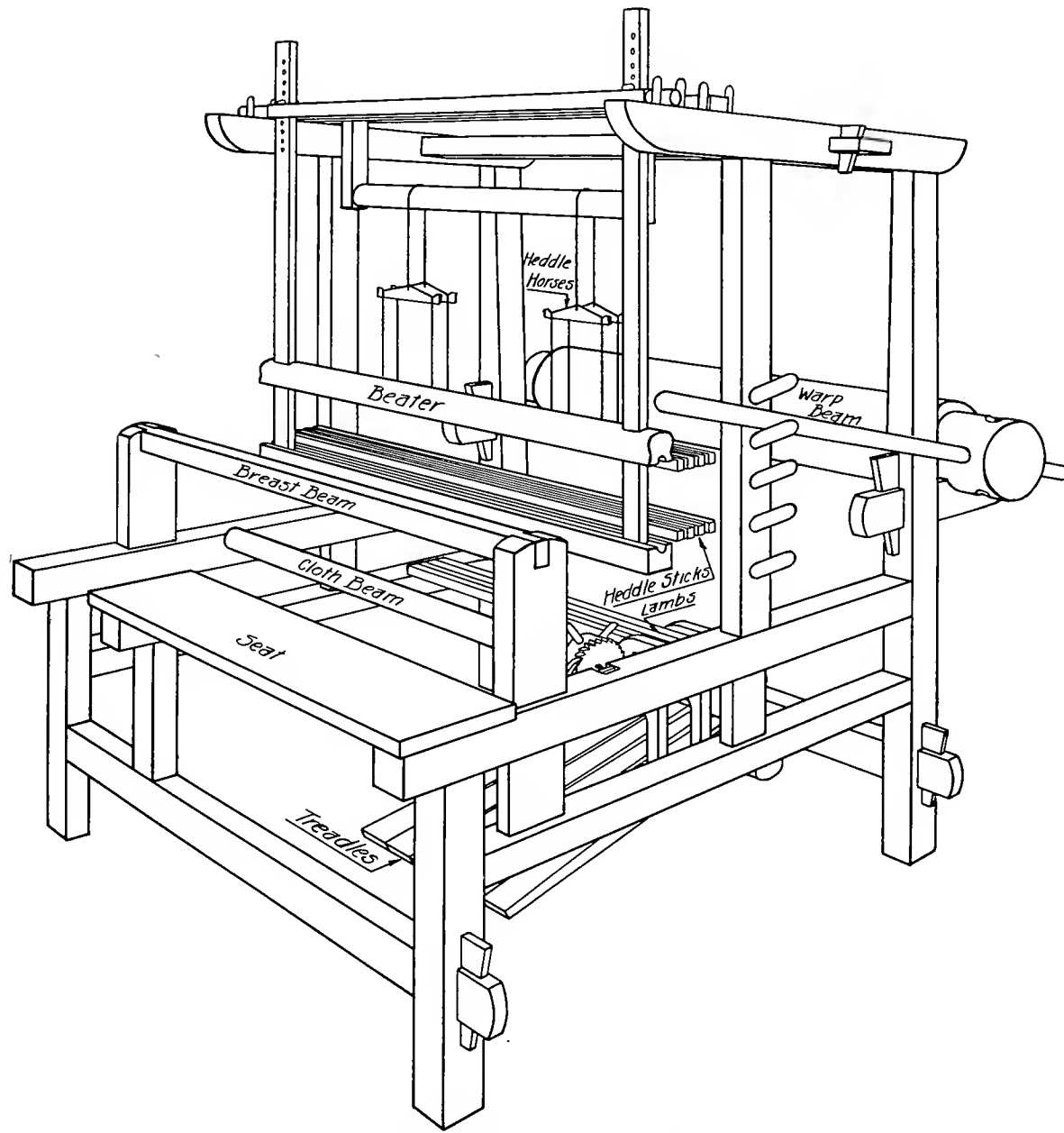


Fig. 428—Finished Loom—Swedish

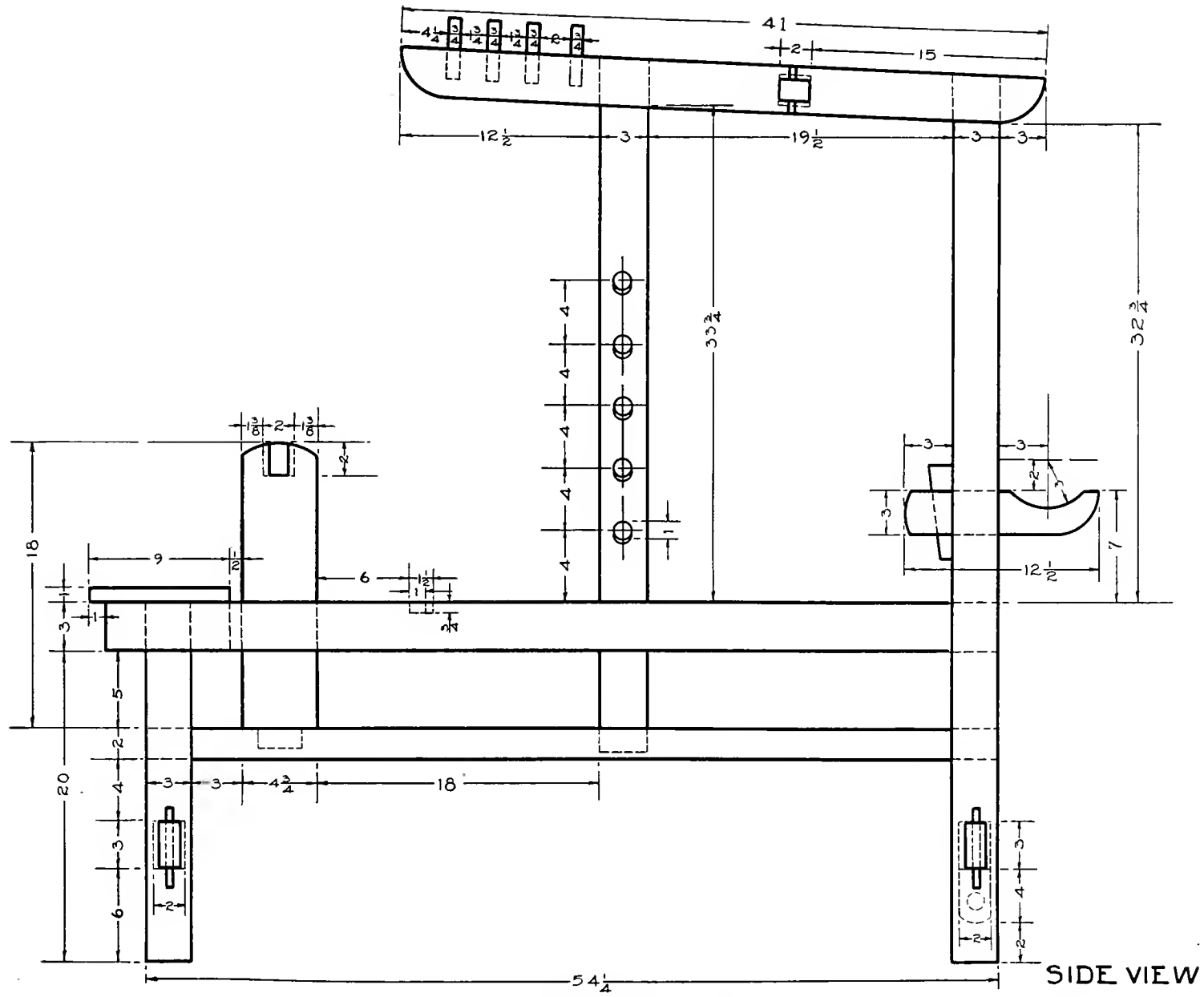


Fig. 430—Working Drawing of Swedish Loom

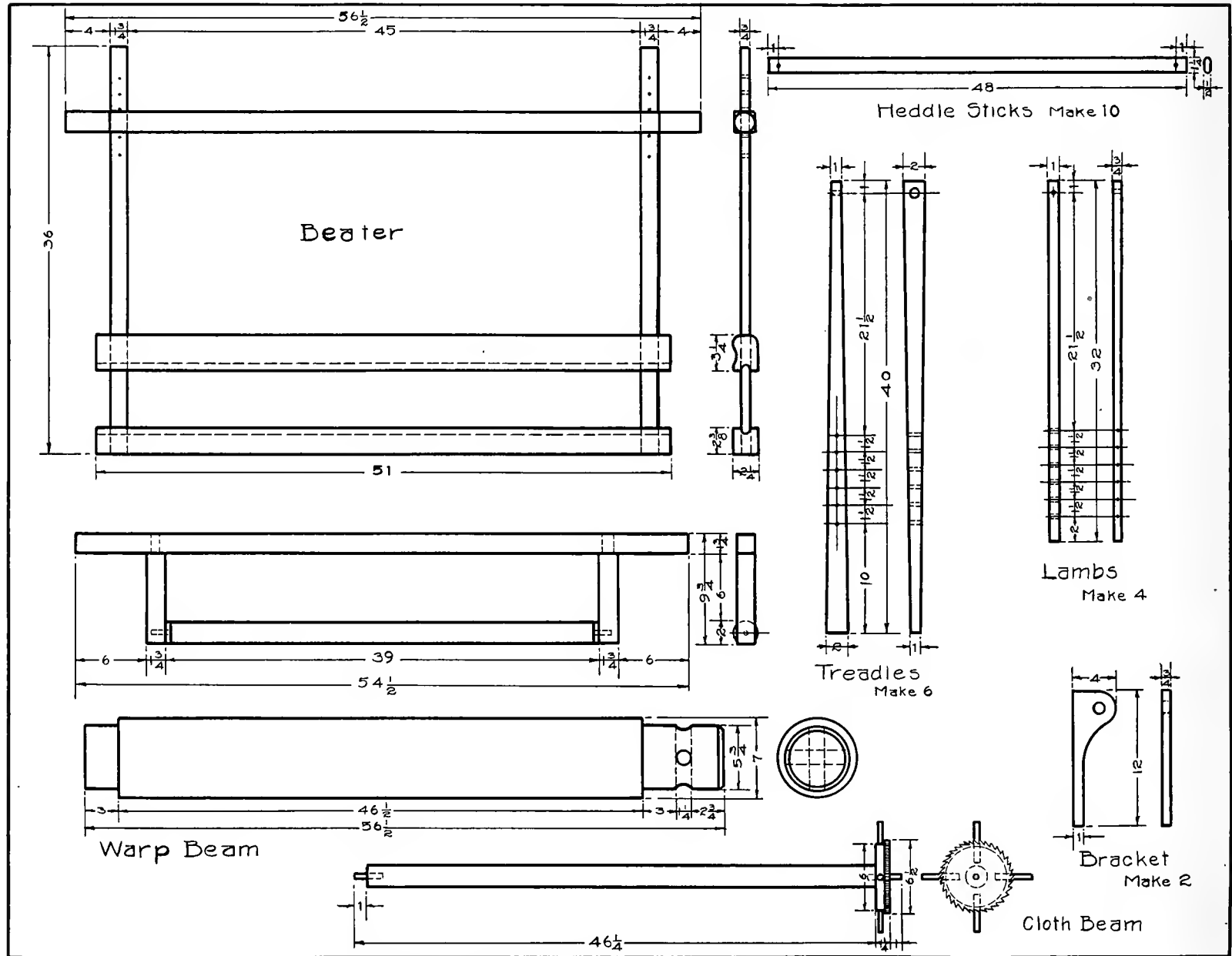


Fig. 431—Working Drawing of Swedish Loom—Details

CHAPTER IX

Dyes and Dyeing

When we come to the coloring of materials to be used in textile work a field is entered that has been only partially explored.

It is true that vegetable dyes may be duller and that they do not run through such a lengthy, diverse and brilliant gamut as the various branches of aniline. But, they are apt to be more permanent and they are so softened by the mellowing touch of time, as to gain with age an exquisite combination of color values, altogether inimitable.

It is claimed that the Shah of Persia punishes with death, the man who brings aniline dyes into his kingdom. Vegetable dyeing is a fascinating part of textile work. When one is interested he is led to make many new discoveries.

Utensils Used

Copper kettles are the best and when possible should be used in vegetable dyeing. Tin is good for bright colors but is affected by acids. Iron is good for certain plants but is very hard to keep clean. Brass may be used but is not so good as any of the other above named utensils. Enameled ware may

be used but should never be used for food purposes after dyeing.

Cleaning of Utensils

The untinned copper kettles are best cleaned with fine sand and a little sulphuric acid. Vinegar or sour milk may be used.

Washing of Wool

All materials to be dyed must be thoroughly clean.

Wool is usually washed but very little before spinning. To obtain the best results the skeins of yarn must not be too thick. Ordinarily 80 grams in weight to the hank is quite sufficient. The finer the yarn, however, the less there should be to the hank. It must be remembered that to obtain definite results care must be taken to weigh all materials to be dyed and to hold to definite measurements.

Water Used in Washing

Rain water is the best for washing purposes. All newly spun and unwashed wool must be washed three times in lukewarm water.

The first washing is done in eight parts of water containing 200 gr. of soda.

The second washing is done in 10 parts of water to 100 gr. of soda and 200 grams of good soap equal in quality to Ivory soap.

The third washing is done in 10 parts of water and 110 grams of soap only.

Care should be taken not to wash too large a quantity of wool at one time. From 2 to 5 kilograms in the bath at one time is quite sufficient.

If the wool is very dirty wash it in two solutions of soda and water and then proceed as above directed.

The washed material is first rinsed in lukewarm water and then in several cold waters.

Mordant

All material is mordanted before dyeing. Sometimes the mordant is placed in the dye itself but more often the material itself is mordanted before placing in the dye. Alum is a useful mordant for most vegetable dyes. When alum is used it must be boiled in order to become thoroughly dissolved. All goods must be wet before entering the mordant.

If vitriols are used in mordanting they must be placed in lukewarm water only. Mordant materials from 1 to 2 hours.

When mordanting the material should be well covered with water.

Formulae for Dyeing

The following recipes have been successfully tried out and are offered to those who are interested enough to not only use what is here suggested but will make further investigation in the broad field of vegetable dyes.

Yellows

1. *Wax Yellow*

Yarn.....250 gr.
Alum (mordant)..... 32 gr.
Fresh bayberry leaves 500 gr.

Mordant before dyeing, boil the leaves one hour, drain, add material and boil one hour.

2. *Greenish Yellow*

Yarn.....250 gr.
Fresh wild parsley..... 1 kg.
Alum (mordant)..... 35 gr.

Boil the parsley one hour, drain, add the alum, stir well until alum has dissolved. Boil material in solution from $\frac{1}{2}$ to 1 hr.

3. *Greenish Yellow*

Yarn.....250 gr.
Alum (mordant)..... 32 gr.
Fresh alder..... 1 kg.

Mordant the material first. Boil the leaves 1 hr., drain, add mordanted material and boil $\frac{1}{2}$ to 1 hr.

4. *Strong Greenish Yellow*

Yarn.....250 gr.
Alum (mordant)..... 40 gr.
Bayberry leaves.....500 gr.

Mordant the material first. Boil the fresh leaves 2 hr., drain and add mordanted yarn, boil from 1 to 2 hr. according to darkness of color desired.

5. *Greenish Yellow*

Yarn.....250 gr.
Dry birch leaves.....500 gr.
Alum (mordant)..... 32 gr.

Soak the leaves the day before using.

Boil the soaked leaves for one hour and strain. Add the alum to this solution and boil yarn in it from $\frac{1}{2}$ to 1 hr.

If the yarn is dried without rinsing and then placed in a weak birch ash lye the color becomes a reddish yellow.

6. *Reddish Yellow*

Yarn.....250 gr.
Alum (mordant)..... 40 gr.
Dry apple bark250 gr.

The material is first mordanted in the alum water.

Cut the bark into small pieces and soak the day before using. It is then boiled two hours and strained.

Boil the mordanted yarn in the bark liquid from $\frac{1}{2}$ to 1 hr.

By using more bark and boiling longer a darker yellow is obtained.

This color fades a little if it is not very dark.

7. *Gray Yellow*

Yarn.....250 gr.
Alum (mordant)..... 40 gr.
Kinnikinnic..... 1 kg.

Chop the kinnikinnic fine and boil for 3 hr. Drain and boil the mordanted material in the liquid from $\frac{1}{2}$ to 1 hr.

8. *Brownish Yellow*

Yarn.....250 gr.
Alum (mordant)..... 32 gr.
Alder bark..... 2 kg.

Mordant the yarn in the usual way. Chop the alder bark fine, and soak the day before using. Boil from 2 to 3 hr., drain and boil the yarn in the liquid 1 hr. or longer according to the depth of color desired.

Reds

9. *Dark Red*

Yarn.....250 gr.
Alum..... 65 gr. } Mordant
Cream of tartar..... 16 gr. }
Madder.....250 gr.

Mordant the yarn for two hours and let it remain in the liquid till cool, then rinse in lukewarm water.

The yarn may be allowed to dry after removing from the mordant; then it is rinsed in warm water before it is put in the madder liquid.

The madder is put to soak the day before it is to be used in enough cold water to make a very thin solution.

If there are hard lumps they must be rubbed apart in order to thoroughly soak. When ready to dye the soaked madder mass is put in clean cold water and when lukewarm the mordanted yarn is added.

This is heated slowly to 60 degrees or 70 degrees Centigrade or hot enough to burn one's fingers. Stir the yarn constantly and keep the solution at the same temperature as long as the yarn is in it. It *must not boil*. If the yarn is not stirred it becomes spotted as that part of the madder liquid that heats the quickest gives a stronger color than the other. The red coloring matter in the madder dissolves without boiling, but with boiling the other ingredients in the madder are also dissolved and these cause the red color to lose its brightness and change it to brown. When the yarn has been in the madder liquid for the required time it is allowed to remain in the solution until cool. Keep stirring until cool.

It is then rinsed and washed in several waters to remove the loose madder.

When the yarn is allowed to dry after being mordanted the red color becomes a little darker. All dark madder colors are absolutely fast. The lighter ones fade a little as the years go by.

10. *Medium Madder Red*

Yarn.....	250 gr.	} Mordant
Alum.....	40 gr.	
Cream of tartar.....	16 gr.	
Madder.....	175 gr.	

Treat the same as No. 9.

11. *Light Madder*

Yarn.....	250 gr.
Alum (mordant).....	40 gr.
Madder.....	125 gr.

Mordant the yarn one hour and keep it in the warm color liquid from $\frac{1}{2}$ to 1 hr.

12. *Light Yellowish Red*

Yarn.....	250 gr.
Alum (mordant).....	40 gr.
Madder.....	75 gr.

Mordant as in No. 11 but keep the yarn in the color liquid only $\frac{1}{2}$ hr.

13. *Pale Red*

Yarn.....	250 gr.
Alum (mordant).....	32 gr.
Madder.....	25 gr.

Treat as in No. 12.

14. *Rose Red*

Yarn.....	250 gr.
Alum (mordant).....	40 gr.
Madder.....	50 gr.

Mordant the yarn as usual; when cool wrap the wet material in a cloth so it does not dry out.

Allow it to lie in this way from 6 to 8 days. It is then treated with madder as above mentioned.

The yarn should be squeezed in a little lukewarm water before putting it in the color liquid.

15. *Terra Cotta*

Yarn.....	250 gr.	} Mordant
Alum.....	48 gr.	
Cream of tartar.....	16 gr.	
Madder.....	125 gr.	
Oak gall.....	13 gr.	

Mordant the yarn as usual.

When the madder liquid is lukewarm add the yarn and heat slowly, allow it to boil $\frac{1}{2}$ hr. Remove the yarn and to the liquid add the finely powdered oak galls.

The yarn is again placed in the color liquid and boiled for $\frac{1}{2}$ hr., when it is removed and allowed to dry.

If more color is used the yarn will be darker, and if from 3 to 10 gr. of iron vitriol is added it becomes browner.

How to Add Vitriol: When this is added the yarn is first removed and the vitriol is allowed to melt in the boiling liquid. This is cooled by adding a little cold water. The yarn is now returned and boiled for a few minutes, then it is removed, cooled and rinsed.

The lighter madder color may be had by coloring the mordanted yarn in the cool liquid left in

No. 9, 10 or 11. These colors are somewhat more of a yellowish color than when fresh madder is used.

By using stronger or weaker mordants and more or less madder many colors not mentioned in these recipes may be made.

It must always be remembered that a strong mordant is used when a dark color is desired.

16. *Cardinal*

Yarn.....	250 gr.	} Mordant
Tin.....	4 gr.	
Nitric acid.....	50 gr.	
Water.....	150 to 200 gr.	
Cream of tartar.....	50 gr.	
Cochineal.....	100 gr.	

The cream of tartar and the cochineal are soaked. When the water for the coloring is boiling add the cochineal and cream of tartar and boil for ten minutes. Keep the liquid well skimmed. After the scum has been removed add the yellowish solution of tin, water, and acid and stir well. Put in the dry yarn, turning it quickly around and later more slowly. Boil from 1 to $1\frac{1}{2}$ hr., according to darkness of color desired. Remove, cool and dry.

17. *Purple Red*

Yarn.....	250 gr.	} Mordant
Tin.....	4 gr.	
Nitric acid.....	25 gr.	
Water.....	75 to 100 gr.	

Cream of tartar..... 50 gr.
Cochineal..... 50 gr.

Treat the same as in No. 16.

18. *Bright Red*

Yarn.....250 gr.
Tin..... 8 gr. } Mordant
Nitric acid..... 50 gr. }
Water.....150 to 200 gr. }
Cream of tartar..... 50 gr.
Cochineal..... 25 gr.

When the water for the coloring comes to a boil, put in the cream of tartar and let it dissolve; add the cochineal. Boil for 10 minutes, keeping the scum skimmed from the surface of the boiling mixture.

Add the yellowish tin solution as in No. 17 and put the dry yarn into the boiling mixture, turn it quickly around and later turn a little more slowly. Boil 1 hr.

19. *Flag Color*

Yarn.....250 gr.
Tin..... 8 gr. } Mordant
Nitric acid..... 50 gr. }
Water.....150 to 200 gr. }
Cream of tartar..... 50 gr.
Cochineal..... 50 gr.

Treat the same as in No. 18.

20. *Dark Carmine*

Yarn.....250 gr.

Cream of tartar..... 16 gr. } Mordant
Alum..... 8 gr. }
Cochineal..... 16 gr.

Mordant the yarn for 2 hrs. and cool. In fresh water put the powdered soaked cochineal and boil for 15 minutes.

The yarn is added and boiled for 2 hrs., when it is taken out and dried.

21. *Carmine*

Yarn.....250 gr.
Alum (mordant)..... 40 gr.

Mordant the yarn as usual.

Boil the yarn for $\frac{1}{2}$ hr. in the solution left in 16 or 17. The color becomes lighter after the use of No. 17 than after No. 16.

22. *Light Carmine*

Yarn.....250 gr.
Alum..... 32 gr. } Mordant
Cream of tartar..... 32 gr. }
Starch..... 32 gr. }
Cochineal..... 15 gr.
Cream of tartar..... 6 gr.

Mordant the yarn 1 hr.

The starch must be mixed with a little cold water before it is added to the mordant.

Boil the soaked cochineal and cream of tartar in fresh water for 15 minutes.

The mordanted yarn is boiled in this from $\frac{1}{2}$ to 1 hr.

23. *Dull Carmine*

Yarn.....	250 gr.	} Mordant
Alum.....	50 gr.	
Cream of tartar.....	32 gr.	
Cochineal.....	25 gr.	
Madder.....	20 gr.	
Starch.....	13 gr.	

Mordant as usual.

Soak the cochineal and the madder together and boil for 10 minutes.

Dissolve the starch in cold water and put it in before the yarn is added to the cold solution, boil from $\frac{1}{2}$ to 1 hr.

24. *Rose Red*

Yarn.....	250 gr.
Alum (mordant).....	32 gr.

Boil $\frac{1}{2}$ hr. in mordant.

Boil $\frac{1}{2}$ hr. in solution left in 17. If the color is to be of a light shade double the amount of yarn or throw away half the color solution and add clear water.

25. *Salmon Red.*

Yarn.....	250 gr.
-----------	---------

The dry unmordanted yarn is boiled from $\frac{1}{4}$ to $\frac{1}{2}$ hr. in the solution left in No. 18 or No. 19. If more yarn is taken the color becomes lighter; it is also lighter when using No. 18 than when using No. 19.

26. *Red from Brazil Wood*

Yarn.....	250 gr.	} Mordant
Alum.....	40 gr.	
Cream of tartar.....	16 gr.	
Madder.....	40 gr.	
Brazil wood.....	40 gr.	
Potash.....	7 gr.	

Mordant as usual, after which the yarn is placed in madder solution as described in No. 9 and allowed to remain 1 hr. The Brazil wood which has been soaked is placed in a bag and this is boiled in clean water $\frac{1}{2}$ hr. The bag is now removed and the madder colored yarn is now boiled in this solution from $\frac{1}{2}$ to 1 hr. Let it lie in this solution till cooled a little. Then it is taken out and the potash, which has been well dissolved, is added to the solution and the yarn is re-entered and left for 10 or 15 minutes. Allow the yarn to remain in the solution till cool and then wash in strong soap suds. This is an inexpensive red blue color but it is not so pretty as the Salmon Red.

27. *Red*

Yarn.....	250 gr.	} Mordant
Alum.....	40 gr.	
Cream of tartar.....	16 gr.	
Bed straw roots.....	250 gr.	

Mordant the yarn from 1 to 2 hrs.

The dry roots are ground or chopped fine and put to soak.

During the dyeing the yarn is treated the same as was described in No. 9, for madder coloring, but in this case the yarn is boiled a little toward the end.

28. *Dark Red.*

Yarn.....250 gr.
Ground pine (mordant)...250 gr.
Madder or bed straw.....250 gr.

Mordant the yarn in ground pine in the following way:

The ground pine is chopped fine and soaked in as much water as is needed for the dyeing. This mixture is heated every day and must remain in a warm place where it can be kept lukewarm. After 3 or 4 days it acquires a sour smell. Boil well and strain. As it boils add a little water. In this strained solution put the wet yarn and heat every day for three or four days and let it stand in a warm place. The last day boil well.

The yarn will then have a light yellowish, green gray color and a sour smell.

The yarn is now rinsed and allowed to dry before it is colored red.

The madder is prepared as described in No. 9. Before the yarn is put into the red dye it must be well squeezed in warm water.

The Preparation of Olium

The Norwegians succeed in getting most beauti-

ful shades of blue through the use of what they call Olium, which is made in the following way:

Indigo is dissolved with sulphuric acid by mixing 15 gr. powdered indigo with 125 gr. of smoking sulphuric acid. Put about 10 gr. of sulphuric acid and a little indigo—say 2 gr.—in a glass jar or bottle with a well fitting stopper. Stir this till it is smooth. Use a glass rod, or if necessary a hardwood stick. Metal must not be used. After this, put a little of each into the jar and stir, and so continue until all has been used. Put stopper firmly in bottle and allow the mixture to stand at least 24 hours before using.

When using, weigh or measure the Olium in a dry glass and pour carefully into cold water before placing in the dye. *Never* pour water into the Olium, as it effervesces and may injure the eyes. When the Olium is kept in an air tight bottle, it may be kept for a long time.

All the recipes for blue which follow, are based on Olium measured in a graduated glass. If weighed, take double as many grams. If the sulphuric acid is poor, the indigo will not dissolve, and the color will run. To prove that the indigo is well dissolved, take a few drops of the Olium, mix with water, and strain through a filtering paper. If the filtered dye is still blue, then the indigo has been properly dissolved, but if not, the dye will be white or light blue.

When Olium is to be used in dyeing, it should be measured or weighed in a dry glass, as before described, and dropped or poured slowly into the lukewarm water and well stirred.

If the color is too light, more Olium may be added, but some of the boiling dye liquid must be thrown away, and the remainder mixed with cold water before the Olium is added. If the liquid is too warm, when the goods is put in, it becomes streaked or clouded, even though it has been dyed previously. As soon as the yarn has been boiled in the dye, it will be seen whether it is too light as by that time all dye will have been drawn into the goods. If in the heating, it is getting too dark, a part of the liquid is thrown out and the remainder lightened with water before continuing the dyeing. When dyeing with Olium, the liquid must only be lukewarm when the goods is put in and it must be quickly stirred and kept in constant motion until it boils.

By using more or less Olium, many color shades and tints in blue may be obtained by using the following recipes. *Blue Dyes*

29. *Dark Soldier Blue*

Yarn.....250 gr.
Alum (mordant)..... 50 gr.
Olium.....20 to 30 gr.

The yarn is mordanted as usual, and is then dyed red in the used liquid remaining after dyeing

cochineal red. Dry the yarn. Add 10 gr. Olium to clear lukewarm water, and stir well. Add the red dyed yarn which has first been dipped in warm water and heat, stirring constantly; boil for $\frac{1}{2}$ hr. and dry. When dry, it is again wrung in warm water so that it becomes thoroughly wet. To the new lukewarm water, is added 10 gr. Olium and the yarn is again dyed as at first. Boil 1 hr. and dry. If one desires the yarn still darker, the dyeing must be repeated with 10 gr. Olium. When the dyeing is completed, it must be dried before washing.

If there is no red liquid which has been used, the yarn must be mordanted as No. 21, and a dye liquid made of cochineal (10 to 15 gr.). For the rest, handle as above.

The darker the blue that is wanted, the darker must be the red of the under dye, with the corresponding amount of Olium added.

30. *Light Soldier Blue*

Yarn.....	250 gr.	} Mordant
Alum.....	75 gr.	
Olium.....	15 gr.	
Madder.....	5 gr.	
Olium.....	10 gr.	

The yarn is mordanted as usual. Fresh water is added to the soaked madder, and in this the yarn is dyed red as in No. 23, and then dried.

The Olium is added to lukewarm water and well stirred. The red dyed yarn is added. (The yarn

must first be wrung out of warm water.) It is then heated slowly, stirred constantly and boiled 1 hr. Handle as above.

It may also be dyed red in *used* madder liquid.

31. *Greenish Blue*

Yarn.....250 gr.
Alum (mordant)..... 40 gr.
Olium..... 8 gr.

When the yarn has been mordanted, it is dyed light yellow in one of the used yellow dye liquids. It is wrung out of this and then dyed blue as above. If a paler dye is wanted, add 5 gr. of iron sulphate after it has been dyed blue, and boil 10 to 15 minutes. It may now be washed without first drying.

Goods dyed with iron sulphate must be left well covered by the dye until cool, unless they are constantly stirred in the dye. This liquid forms a crust on the surface in the cooling which spots the goods or yarn near the surface.

32. *Dull Medium Blue*

Alum (mordant)..... 40 gr.
Olium..... 8 gr.
Madder..... 15 gr.

The yarn is mordanted as usual. Some of the mordant water is thrown away and enough cold water is added to make the liquid lukewarm. Add the Olium, stir well, put in the yarn and heat slowly, stirring constantly.

Boil $\frac{1}{2}$ hour and take out. Add enough cold

water to the liquid to make it lukewarm and add the dissolved madder and stir well. Add the yarn and heat slowly, stirring constantly and evenly. Boil $\frac{1}{2}$ hr., then cool, rinse and wash.

33. *Bright Medium Blue.*

Yarn.....250 gr.
Alum (mordant)..... 40 gr.
Olium..... 5 gr.

The yarn is mordanted and dyed as above. When it is through boiling in the dye liquid the yarn is cooled, rinsed and washed.

34. *Light Blue.*

Yarn.....250 gr.
Alum (mordant)..... 30 gr.

Handle the same as above.

35. *Water Blue*

Yarn.....250 gr.
Alum (mordant)..... 30 gr.
Olium.....5 to 10 drops

Handle as above.

The lighter colors with Olium are not absolutely fast. They become slightly greenish after being used and cannot be washed in soda water.

36. *Dark Blue with Ground Pine*

Yarn.....250 gr.
Ground pine.....250 gr.
Logwood.....100 gr.

The ground pine is chopped fine and soaked in as much water as is needed for the dyeing. The

whole is heated daily and is placed where it can be kept lukewarm. When after three or four days it has acquired a sourish odor, it should be well boiled and strained. The water will diminish in the boiling, therefore sufficient water must be added so that there is enough for dyeing. When the ground pine has been strained, the wet yarn is placed in the liquid and heated every day for three or four days and kept in a warm place. The last day it is boiled; the yarn should then have a light, yellowish, green gray color and a sour odor.

The logwood, which was put to soak the day before, is placed in a bag and boiled in clear water 1 hr. and then removed. The yarn is now wrung out of the ground pine liquid and boiled in the logwood liquid $\frac{1}{2}$ to 1 hr. It is then taken out and dried. When dry, place it for several hours in a weak birch ash lye and wash. The lye is made by putting the ashes in warm water.

With more logwood, a darker color is obtained.

This color is fast for covering but should not be used for finer covers or rugs. In time it becomes slightly grayish in color.

37. *Dark Blue with Chickweed*

Yarn.....	250 gr.
Fresh chickweed	1 <i>pail</i>
Alum (mordant).....	32 gr.
Logwood.....	50 gr.

The chickweed is boiled 1 hr. and drained. The alum is added to the liquid, and well stirred. The wet unmordanted yarn is taken, and added to the liquid and boiled 1 hr. and taken out. A small bag filled with the soaked logwood is boiled in the liquid $\frac{1}{2}$ hr.

Add the yarn and let it boil 1 hr. with the logwood bag.

The yarn lies in the liquid until cold.

If a darker dye is wanted, use more logwood.

Green Dyes

The pure green colors are always composed of a yellow and blue dye stuff. These are mostly made by first dyeing the goods blue, and then boiling it in a yellow dye. To obtain a dark green the blue foundation must be made dark enough the first time. No amount of boiling in the yellow dye will make the goods darker. By adding madder or iron sulphate, the green will become darker but it is another tone, gray or brownish.

Certain plants give a green dye without using blue. The yellow dye in these plants will, by the addition of an iron or copper salt, become green, but the yarn will have a shade of gray or brown.

Green with Birch Leaves

For these dyes, both fresh and dried leaves may be used. Three kg. fresh leaves make 1 kg. dried leaves.

We must therefore count on using three times as much fresh leaves as dried in the dyeing. The recipes are made on the basis of dried leaves. The leaves are soaked the day before and are boiled in enough water to make the necessary dye liquid and are then strained. The boiling is done so that all dye material in the leaves may be had. After straining, the leaves are rinsed with a little clear water, and this is added to the liquid which is cooled while one is dyeing the yarn blue.

The yarn is mordanted with the amount of alum called for in the recipe.

When dyeing blue, throw out half the mordant water and add clear cold water and the proper amount of *Olium*.

Olium is measured in a graduated glass or is dropped (counting the drops) carefully into the water which has been heated to about 20° C, and is well stirred. The wet, well wrung yarn, already mordanted, is placed immediately in the lukewarm blue liquid. It is stirred and turned quickly around with a stick. This is kept up constantly and while the liquid is slowly boiling. By that time, all the dye-stuff will have been absorbed by the yarn and it may be left to boil slowly $\frac{1}{2}$ hr.

Unless one is exceedingly careful in the blue dyeing, the yarn becomes clouded and this cannot be

corrected later, but becomes more noticeable when dyed green.

When the yarn has been dyed, it is cooled in the liquid before it is taken out. It is then well wrung, put again on the stick and placed in the milk-warm, (about 30° C,) birch-leaf liquid. It is constantly turned and kept in slow motion until through boiling. The longer it is kept in the birch-leaf liquid, the stronger the green color. It should not boil more than 1 hr. If the yarn is not dark enough, due to poor leaves, it must be boiled for half an hour, in new birch-leaf dye after having been dried. It must be thoroughly wet in warm water before being placed in the new dye. The goods is allowed to lie in the dye until cold unless the color is becoming too strong. In that case, it is taken up at once and cooled. The color is intensified by having the material lie in the warm dye until it is cold.

If there are to be several dyes in green, these can well be boiled in the same birch-leaf dye. It is necessary to calculate in advance the proper amount of leaves and to make up separately the blue dyes.

If the birch-leaf dye is to be used for after-dyeing, it must be cooled before new yarn can be placed in it.

The dull blue green dyes may also be boiled in the same birch-leaf dye that the light fresh green colors were boiled.

For the light after-dyes, add to the cooled dye 1 to 5 drops Olium, if only light colors have been boiled in it and it contains no blue.

Whenever dark dyed blue has been boiled in the birch leaf, some of the blue remains.

Yarn and cloth are handled in the same way, with the exception that wool is to be boiled slowly, while cloth is boiled quickly and kept in constant motion.

Variations of the birch-leaf dyeing are endless among the following recipes:

38. *Dark Blue Green No. 1*

Yarn.....250 gr.
Alum (mordant)..... 40 gr.
Olium (blue dye)..... 5 gr.
Birch leaves..... 1 kg.

Boil in birch-leaf liquid $\frac{1}{2}$ to 1 hr. according as a more or less blue-green color is desired.

39. *Dark Blue Green No. 2*

Yarn.....250 gr.
Alum (mordant)..... 40 gr.
Olium (blue dye)..... 3 gr.
Birch leaves..... 1 kg.

Boil in birch-leaf liquid 1 hr.

40. *Medium Blue Green*

Yarn.....250 gr.
Alum (mordant)..... 40 gr.
Olium (blue dye)..... 2 gr.
Birch leaves.....750 gr.

Boil in birch-leaf dye 1 hr.

41. *Light Blue Green*

Yarn.....250 gr.
Alum (mordant)..... 40 gr.
Olium (blue dye)..... 1 gr.
Birch leaves.....500 gr.

Boil in birch-leaf dye $\frac{1}{2}$ to 1 hr.

42. *Dark Strong Green*

Yarn.....250 gr.
Alum (mordant)..... 50 gr.
Olium (blue dye)..... 3 gr.
Birch leaves..... 1 $\frac{1}{2}$ kg.

Boil in birch-leaf dye 1 hr.

If the dye is not green enough, dry the yarn and boil again in a new strong birch-leaf dye $\frac{1}{2}$ to 1 hr.

43. *Bright Medium Green*

Yarn.....250 gr.
Alum (mordant)..... 40 gr.
Olium (blue dye)..... 1 gr.
Birch leaves..... 1 kg.

Boil in birch-leaf dye $\frac{1}{2}$ to 1 hr.

44. *Light Green*

Yarn.....250 gr.
Alum (mordant)..... 40 gr.
Olium (blue dye)..... 1 gr.
Birch leaves..... 1 kg.

Boil in birch-leaf dye $\frac{1}{2}$ to 1 hr.

45. *Yellow Green*

Yarn.....250 gr.
Alum (mordant)..... 30 gr.

Olium (blue dye)..... 15 drops
 Birch leaves..... 1 kg.
 Boil in birch-leaf dye $\frac{1}{2}$ to 1 hr.

46. *Dull Grass Green*

Yarn.....250 gr.
 Alum (mordant)..... 40 gr.
 Olium (blue dye)..... $1\frac{1}{2}$ gr.
 Birch leaves..... 1 kg.
 Iron sulphate..... 2 to 5 gr.

Boil in birch-leaf dye 1 hr.

When the yarn has boiled in the birch-leaf dye, it is taken out of the liquid and the iron sulphate is added and stirred well. The liquid is cooled with a little cold water, the green dyed yarn put in again and is boiled, stirring constantly for 10 or 15 minutes.

The yarn must not lie in this liquid, but must be taken out as soon as boiled.

47. *Gray Green*

Yarn.....250 gr.
 Olium (blue dye)..... 2 gr.
 Birch leaves..... 1 kg.
 Common madder..... 25 gr.
 Iron sulphate vitriol..... 4 gr.

Boil in birch-leaf 1 hr. and then take out. Cool the liquid and add the 25 gr. soaked madder. Place the yarn in the cooled liquid and let it boil $\frac{1}{4}$ hr., take it out, add the iron sulphate, cool, put in the yarn, and boil $\frac{1}{4}$ hr.

Handle as above.

48. *Pale Blue Green*

Yarn.....250 gr.
 Alum (mordant)..... 30 gr.

The mordanted yarn is placed in the cooled after-dye, of No. 50, and slowly heated to the boiling point. Boil $\frac{1}{2}$ to 1 hr.

49. *Pale Yellow Green*

Yarn.....250 gr.
 Alum (mordant)..... 30 gr.

Boil in the same manner as suggested in No. 40, 42 and 43.

50. *Olive Green with Heather*

Yarn.....250 gr.
 Alum (mordant)..... 40 gr.
 Fresh heather tops..... 1 to 2 kg.

Chop the heather and soak and then boil 4 hrs. in a polished iron kettle. When the liquid is put back, the yarn is boiled slowly 1 to 2 hrs. according to the darkness of color desired. Let it lie in the dye till cool, but it must be stirred occasionally. If the liquid is allowed to form a crust, this will spot the yarn.

51. *Gray Green with Bayberry*

Yarn.....250 gr.
 Alum (mordant)..... 40 gr.
 Dried bayberry leaves 500 gr.
 Iron sulphate..... 10 to 20 gr.

Soak the bayberry leaves and boil 2 hrs. The mordanted yarn is boiled in the strained liquid for

1 hr. and is then taken out. Add the iron sulphate and when this is dissolved add a little cold water. Place the yellow dyed yarn in the cooled liquid, heat slowly, stirring constantly and let it boil 5 to 10 minutes. Take it out and cool.

52. *Myrtle Green*

Yarn.....	250 gr.	} Mordant
Potassium chromate.....	4 gr.	
Cream of tartar.....	4 gr.	
Mulberry wood.....	90 gr.	
Logwood.....	25 gr.	

The potassium chromate and the cream of tartar are dissolved in boiling water, and enough cold water added to make the liquid lukewarm. Place the wet yarn in this and heat slowly, stir, boil one hour and let it lie in this mordant until cold. Rinse in clear water before placing in the dye. The mulberry and logwood are put to soak the day previous. They are put in a bag and boiled in clear water 2 hrs. Take out the bag and boil the wet mordanted yarn in this dye 2 hrs. If there is room in the kettle, time may be saved by boiling the yarn with the bag the last hour. If more logwood is used, the color will be darker—less logwood makes it lighter.

53. *Dark Grass Green.*

Yarn.....	250 gr.
Mulberry.....	80 gr.

Alum.....	40 gr.
Olium.....	10 gr.

The mulberry wood is put to soak the day before, boiled 1 hr. and strained. In the strained liquid, dissolve the alum and when the liquid is milk warm, add the Olium. It is all well stirred. The wet mordanted yarn is put in and stirred constantly. Heat slowly and boil 1 hr. The yarn is left in the dye until cold.

54. *Olive Green.*

Yarn.....	250 gr.
Alum (mordant).....	40 gr.
Olium (blue dye).....	5 gr.
Mulberry.....	62 gr.
Tameric Acid.....	40 gr.
Madder.....	13 gr.
Iron sulphate.....	3 gr.

The yarn is mordanted and dyed blue, just as is done in birch-leaf dyeing. The mulberry having been soaked, is put in a bag and boiled in clear water 1 hr.

Take out the bag and add the tameric. Boil before putting in the blue-dyed yarn, which must not be cooled too much. When it has boiled 1 hr. in the yellowish liquid, it is taken out. The dye is cooled with cold water to about 40° C, and the soaked madder is added. Put the yarn in again and slowly heat to boiling. Boil $\frac{1}{2}$ hr.

Dissolve the iron sulphate and add it to the

cooled liquid, after taking out the yarn. Stir well. Put yarn back and boil for $\frac{1}{4}$ to $\frac{1}{2}$ hr. Take out immediately and cool.

With more madder, the color becomes browner, with less, more green. More iron sulphate makes it duller. If the madder is omitted, the color becomes a pure green.

These colors are not durable. In time they become brown or grayish.

Violet Dyes

Violet dyes are compounded of blue and red. As a rule, indigo, cochineal and madder are used. The colors made by these dye stuffs are fast when they are not too light in color.

With cochineal, the color becomes a pure violet, with more or less red according to the proportion of blue and red dye. With madder and cochineal, the color is more brownish or plum color. The depth of the color is much affected by the quality of the wool according as it is coarse or fine. The latter becomes the darker.

Light violet dyes become dull and not satisfactory in coarse or hard cloth. The finer dye shades require soft wool.

By using different kinds of mordant, violet shades may be obtained from the blue dye in log-wood.

These colors are not as pretty or fast as the others above mentioned.

Violet with Cochineal

For violet, the yarn must first be dyed blue, then red.

The yarn is done in the same manner as for green. When the yarn has been boiled in the blue dye, it is dried without rinsing.

Cochineal is powdered fine and put to soak the day before doing the red dyeing. It is then put in clear water, boiled for ten minutes and well skimmed. Lay the dry blue-dyed yarn in the boiling dye, turn it around quickly so that it gets wet, and boil, stirring constantly for the required time; then take it out and cool before washing.

If the color does not seem to be red enough, the yarn may be left in the dye until cold. This will help with colors which have a very dark blue ground. In that case, add a little more soaked cochineal and let the yarn boil longer.

If the color is redder than desired, boil the yarn a shorter time in the red dye, but not less than half an hour.

If the foundation blue color is too light, this cannot be remedied after the yarn has been in the cochineal dye.

Among the following recipes are many possibilities by varying the relation between Olium and cochineal.

55. *Dark Black Violet*

Yarn.....250 gr.
Alum (mordant)..... 50 gr.
Olium (blue dye)..... 10 gr.
Cochineal..... 50 gr.

Mordant the yarn as usual and dye blue. When dry, boil 1 hr. in cochineal dye.

56. *Dark Blue Violet*

Yarn.....250 gr.
Alum (mordant)..... 50 gr.
Olium (blue dye)..... 5 gr.
Cochineal..... 25 gr.

Handle as No. 55.

57. *Medium Blue Violet*

Yarn.....250 gr.
Alum (mordant)..... 50 gr.
Olium (blue dye)..... 3 gr.
Cochineal..... 15 gr.

Handle as above but boil $\frac{1}{2}$ to 1 hr.

58. *Blue Violet*

Yarn.....250 gr.
Alum (mordant)..... 40 gr.
Olium (blue dye)..... 50 drops
Cochineal..... 5 gr.

Handle as above.

59. *Light Blue Violet*

Yarn.....250 gr.
Alum (mordant)..... 32 gr.

When the yarn has been mordanted, boil for $\frac{1}{2}$ hr. in the after color of No. 56.

60. *Dark Red Violet*

Yarn.....250 gr.
Alum (mordant)..... 50 gr.
Olium (blue dye)..... 4 gr.
Cochineal..... 40 gr.

The yarn is mordanted and dyed blue as the former have been and is boiled in the red dye $\frac{1}{2}$ to 1 hr. according to the redness required.

61. *Indian Red Violet*

Yarn.....250 gr.
Alum (mordant)..... 50 gr.
Olium (blue dye)..... 2 gr.
Cochineal..... 20 gr.

Handle as above.

62. *Bright Red Violet*

Yarn.....250 gr.
Alum (mordant)..... 40 gr.
Olium (blue dye)..... 30 drops
Cochineal..... 10 gr.

Handle as above.

63. *Light Red Violet*

Yarn.....250 gr.
Alum (mordant)..... 32 gr.

Handle as No. 59 and boil in the red after-dye of No. 60 or No. 61.

Violet with Cochineal or Madder

When madder is to be used with cochineal for red dyeing of violet, both ingredients must be soaked separately.

Cochineal is boiled as usual 10 minutes, and the liquid is cooled with cold water and the madder is added.

The dry blue yarn must first be squeezed in warm water so that it is wet before it is placed in the milk-warm red dye. In this it is heated and kept near the boiling point, 80° to 90° C, for 1 hr.

If the color is wanted more brown, let the yarn boil in the red dye.

64. *Very Dark Brown Violet*

Yarn.....	250 gr.
Alum (mordant).....	50 gr.
Olium (blue dye).....	8 gr.
Cochineal.....	5 gr.
Madder.....	25 gr.

Mordant the yarn as usual, and dye blue as in the case of former blue violet dyes.

65. *Plum Color*

Yarn.....	250 gr.
Alum (mordant).....	50 gr.
Olium (blue dye).....	3 gr.
Cochineal.....	5 gr.
Madder.....	20 gr.

Handle as above described.

66. *Light Brown Violet*

Yarn.....	250 gr.
Alum (mordant).....	40 gr.
Olium (blue dye).....	1 gr.
Cochineal.....	2 gr.
Madder.....	15 gr.

Handle as before.

In all these red after-dyes, many violet shades may be dyed according as the liquid is dark or light, more or less red or blue. A little of the blue dye will always be left in the red dye.

The yarn for these after-dyes is mordanted as usual and is boiled in the cooled red liquid. It may also be dyed light blue so that the red becomes the chief color.

67. *Blue Violet with Ground Pine*

Yarn.....	250 gr.
Ground pine.....	250 gr.
Logwood.....	50 gr.

Mordant and dye as No. 36.

68. *Blue Violet with Chickweed*

Yarn.....	250 gr.
Chickweed.....	1 pail
Logwood.....	30 gr.
Alum (mordant).....	32 gr.

Mordant and dye as No. 37.

Brown Dyes

Brown is obtained by mixing yellow, red and black dyestuffs.

Several brown dyestuffs are found complete in certain barks and roots and in a number of lichens. From herbs and leaves, brown is seldom obtained.

To bring out the brown colors, a copper or iron salt must often be added to the yellow or red dyestuff. When these salts, such as iron or copper vitriol, are added, they must be well dissolved and the dye must be cooled before the goods is put back in the liquid.

In all dye to which iron or copper vitriol is added, the goods must not lie still after it is through boiling. It is best to take it out immediately, cool quickly and rinse in clean water until it is washed.

A dark scum will always form on the dye when it cools and this will spot the goods. The same effect will be had also if the dye-stuff is allowed to run down a part of the goods after being hung up.

69. *Yellow Brown with Bayberry Leaves*

Yarn.....250 gr.
Alum (mordant)..... 40 gr.
Bayberry leaves (dried)...750 gr.

The yarn is mordanted and dyed as for yellow (see No. 4) and is taken out and 15 to 30 gr. copper sulphate is added. Boil the yarn $\frac{1}{4}$ to 1 hr.

If a very dark color is desired, let it boil again in the same or a new dye. The yarn must be dried between each dyeing just as in the heather dyeing. This is a very fast color.

70. *Yellow Brown with Alder Bark*

Yarn.....250 gr.
Alum 32 gr.
Alder bark (dry)..... 5 kg.

The yarn is mordanted and dyed like the yellow with alder bark (see No. 8). But it is boiled in the liquid 1 to 2 hrs. and left until cold. If wanted still darker it may be dried and boiled again in new alder bark dye. This color darkens in time.

71. *Bronze Brown with Buckthorn Bark.*

Yarn.....250 gr.
Dry bark.....500 gr.
Alum..... 35 gr.

Chop the bark fine, soak and boil 3 hrs. To the strained liquid, add the alum and when it is dissolved, the dry unmordanted yarn is laid in the boiling dye. Boil in this 1 to 2 hrs., and let it remain until cold.

72. *Bronze Brown with Walnut Leaves*

Yarn.....250 gr.
Alum (mordant)..... 40 gr.
Fresh walnut leaves..... 1 kg.

Boil leaves 1 hr. and strain.

The mordanted yarn boils in the dye 1 to 2 hrs. and is left till cold.

73. *Olive Brown with Juniper Berries*

Yarn.....250 gr.

Alum.....	32 gr.	} Mordant
Cream of tartar.....	18 gr.	
Copper sulphate.....	18 gr.	
Ammonia chloride.....	13 gr.	
Juniper berries.....	1 to 2 liter	
Copper acetate.....	16 gr.	

The mordants are dissolved in boiling water and stirred. Put in the yarn and boil one hour and leave until cold.

The dry, ripe berries are broken, put to soak and boiled one hour in clear water. Put in the mordanted yarn and let it boil with the berries 1 to 2 hrs. and then take out. Strain the liquid and add the copper acetate. Boil the yarn again $\frac{1}{4}$ to $\frac{1}{2}$ hr.

74. *Light Red-Brown with Gray Stone Lichens*

Yarn.....	250 gr.
Dry lichens.....	1 kg.

Crush fine the lichens and soak over night, and then boil in a copper kettle in a reasonable amount of water. Boil the unmordanted yarn in this $\frac{1}{2}$ to 2 hrs. As this dye becomes very thick, the yarn must be stirred constantly. The hanks must be hung far apart and be well shaken. This color becomes clouded easily unless this is done.

A fast brown color is the result.

75. *Dark Reddish Brown with Stone Lichens*

Yarn.....	250 gr.
Lichens.....	1 to 1 $\frac{1}{2}$ kg.

Crush fine the stone lichens and strew well between the yarn which is laid in layers with the lichens in an iron kettle. The yarn must be well covered and some large pieces of lichens placed between each layer of yarn. The yarn must be wet when laid down. Pour on cold water. Let it soak a few hours before boiling. Boil slowly and evenly 2 to 6 hrs.

If the yarn is to be very dark, it must be treated again with new lichens and in the same manner. If one has some used madder dye, this may be used instead of water. Wool may be dyed in the same manner. This is more easily dyed but the yarn is apt to be clouded unless one is very careful. It must have plenty of room.

76. *Dark Greenish Brown with Tree Lichens or Moss*

Yarn.....	250 gr.
Lichens.....	1 to 1 $\frac{1}{2}$ kg.

This color is handled as above.

77. *Light Brown with Iceland Moss.*

Yarn.....	250 gr.
Moss.....	250 gr.

Clean, rinse and chop the moss fine. This is placed between the layers of yarn in a kettle. The yarn must be well covered with moss. Pour on water and boil 1 to 2 hrs., or longer. The yarn may also be hung on sticks and boiled with the moss like the light yellow brown with stone lichens.

78. *Dark Brown with Iceland Moss*

- Yarn.....250 gr.
- Moss.....500 to 750 gr.
- Cooking salt..... 50 gr.

The moss is handled as above and laid in layers with the yarn in an iron kettle.

Strew the salt between, and pour on water and keep warm and boil for 48 hrs. It may stand in an oven or on a heating stove.

Handle afterwards like the other lichen colors. If one has not enough lichens, the color may be darkened by adding iron sulphate to the dye. But the yarn must first be taken out. This brown color will be a little more grayish if lichens only are used. All these dyes are absolutely fast.

79. *Sandal Brown (Gray Brown)*

- Yarn.....250 gr.
- Santalic acid..... 50 gr.
- Madder..... 50 gr.
- Mulberry 50 gr.
- Oak gall..... 15 gr.
- Iron sulphate.....10 to 15 gr.

Madder, santalic acid, mulberry and oak gall are pounded fine, put in a bag and boiled $\frac{3}{4}$ hr. The yarn is put dry into the liquid and boiled with the bag $\frac{1}{2}$ hr. and then both are taken out. Add the iron sulphate and cool, and then boil the yarn 5 to 10 minutes.

If wanted darker, use more iron sulphate.

80. *Dark Red-Brown with Madder*

- Yarn.....250 gr.
 - Alum..... 45 gr.
 - Cream of tartar..... 16 gr.
 - Madder.....125 gr.
 - Oak gall..... 12 gr.
 - Iron sulphate..... 10 gr.
- } Mordant

Mordant the yarn as usual 1 hr. Put the soaked madder in clear water. When the liquid is milk warm, add the wet mordanted yarn, heat and boil, keeping in even motion $\frac{1}{4}$ hour and then take out. Add the crushed oak galls and stir. Boil the yarn in this $\frac{1}{2}$ hr. Take out, add iron sulphate, cool a little and put yarn back. Boil, stirring evenly for $\frac{1}{4}$ hr.

Gray Dyes

All plants that contain tannic acid, will make gray dyes.

Many kinds of bark contain much tannic acid from which, by adding iron salts, gray to black dyes may be obtained.

Boil the plants and the material first in this dye, which will give it a yellow, red or greenish color. Remove the goods and add the iron sulphate, which will change the color to gray. This gray will always have a tone of the foundation color which the plant alone gives; but the more iron sulphate that is added, the darker and more gray the color will become.

It is necessary always to maintain accurate proportions between the strength of the dye and the

amount of iron sulphate. In a weak dye, a dark gray dye cannot be obtained, however much iron sulphate is added.

81. *Gray Brown with Alder Bark*

Yarn.....250 gr.
Alum (mordant)..... 32 gr.
Alder bark..... 4 kg.
Iron sulphate.....10 to 30 gr.

Mordant the yarn and dye yellow with alder bark, as in No. 17. When it has boiled one hour in the alder bark, add the iron sulphate (see No. 54) and boil the yarn again $\frac{1}{4}$ to $\frac{1}{2}$ hour.

82. *Gray Violet with Birch Bark*

Yarn.....250 gr.
Dry birchbark.....600 gr.
Iron sulphate.....10 to 20 gr.

The bark is put to soak the day previous and is boiled 1 hr. Strain and boil the unmordanted yarn in the liquid 1 hr. Add the iron sulphate and boil the yarn $\frac{1}{4}$ hr.

83. *Gray Reddish with Mountain Ash Bark*

Yarn.....250 gr.
Alum (mordant)..... 40 gr.
Dry bark..... 2 kg.
Iron sulphate.....30 to 50 gr.

Boil the bark 1 to 2 hrs.—strain. Boil yarn in this dye 1 hr. Add iron sulphate and treat as described in No. 54.

84. *Blue Gray with Kinnikinnic*

Yarn.....250 gr.
Kinnikinnic.....1 to 2 kg.
Iron sulphate.....5 to 20 gr.

The yarn is mordanted and dyed as for yellow (see No. 16). When boiled, add iron sulphate and boil yarn $\frac{1}{4}$ to $\frac{1}{2}$ hr.

85. *Green Gray with Lady's Mantle*

Yarn.....250 gr.
Alum.....260 gr. } Mordant
Cream of tartar..... 16 gr. }
Fresh lady's mantle ... $\frac{1}{2}$ to 1 kg. }
Iron sulphate.....5 to 30 gr.

The yarn is mordanted as usual.

Boil the lady's mantle 1 hr. and strain. Boil the mordanted yarn in this liquid 1 hr. Remove this. Add the iron sulphate. Boil the yarn in the liquid until the color is dark enough.

86. *Green Gray with Sorrel*

Yarn.....250 gr.

When in the sorrel dye, yarn has been dyed black (see No. 89); from the after-dye one can get a gray green after color. The wet unmordanted yarn is boiled $\frac{1}{2}$ to 1 hour or longer in this liquid. The liquid may easily stand 1 to 2 days in an iron kettle.

87. *Gray with Sumac*

Yarn.....250 gr.
Mulberry wood..... 10 gr.
Sumac..... 25 gr.

Oak gall..... 10 gr.
 Iron sulphate..... 10 gr.

The mulberry wood, which has been soaked, is boiled $\frac{1}{2}$ hr., and then the sumac and oak gall are added and boiled. The yarn is placed dry in the boiling dye, and boiled $\frac{1}{2}$ to 1 hr. Iron sulphate as usual is added (see No. 54) and the yarn is again well boiled.

88. *Light Gray.*

Yarn.....250 gr.
 Oak gall..... 3 gr.
 Mulberry wood..... $1\frac{1}{2}$ gr.
 Madder..... $\frac{1}{2}$ gr.
 Iron sulphate..... 3 gr.

The oak gall, mulberry wood, and madder is boiled $\frac{1}{2}$ hr. The dry, unmordanted yarn is put in the boiling dye and boiled $\frac{1}{2}$ hr. The yarn is taken out and the iron sulphate added. The yarn is again put back and boiled $\frac{1}{2}$ hr.

By taking more or less of the different dye-stuffs, the color will have a yellowish, reddish or violet tone. More iron sulphate darkens it.

Black Dyes

Black dyes can, like the gray, be made with the aid of iron salts from the plants containing tannic acid. But they can also be obtained from the blue dye-stuff in logwood. This latter is now most generally used. Although the dye-stuff in logwood is

blue, black may be obtained from it by using different sorts of mordants. In order that the black shall not be too bluish, a little yellow dye should be added to the logwood.

For black dyes, an iron kettle is best. Untinned copper may be used, but not tinned copper kettles.

Logwood is always put in a bag to be boiled and, to save time, the goods may be boiled at the same time as the bag. But it must have plenty of room in the kettle.

Goods dyed black must be dried immediately after dyeing and then washed well in strong soap water and rinsed in clean water until it is absolutely clear. When the black dyes are well boiled and properly handled, they do not crock, but are absolutely fast.

89. *Black with Sorrel*

Yarn.....250 gr.
 Fresh sorrel.....1 to $1\frac{1}{2}$ kg.
 Logwood.....175 gr.
 Birch ashes.....250 gr.

Boil the sorrel 1 to 2 hrs. in a clean scrubbed iron kettle. Strain, scour the kettle before putting the dye back. In this the wet unmordanted yarn is boiled 2 hrs. and lies in the liquid until cold. The yarn should be a dark gray green. Put to soak the logwood, the day before dyeing, and boil in clear water 2 hrs. and take the bag out.

The mordanted yarn which has been squeezed out of the sorrel dye and rinsed in lukewarm water is put in the logwood liquid and boiled 2 hrs. When the logwood dye is nearly cold, it is mixed with 1 to 2 liter of lye which is made by pouring boiling water on the birch ashes, stirred and let stand till cold and clear. Let the yarn lie in this lye for 12 hrs. and then dry. Wash later.

Further Use of Used Dye Liquids

When yellow or red dyes have been made, the after liquid will always contain enough dye so that they may be used again to dye woolens and cotton goods—goods that do not require a decided color. These after-dyes are more or less fast, but are very pretty. The most are fast as regards washing and can be used for articles that are not much exposed to sunshine.

The goods is mordanted and is handled the same as previously described. If one is dyeing rags and such common things, the mordant, if it be alum or cream of tartar, may be put in the after-dye direct.

Yellow After-Dyes

Different yellow after-dyes may be mixed together and the alum added at once. With after-dye of heather, cotton and linen may both be dyed yellow. This is a pretty color for the warp in simple rugs and carpets.

In the after-dye of ground pine, wool and cotton may be dyed. If they be re-boiled in used logwood dye, a good blue gray color is obtained both in wool and cotton. It may be used for warp and carpet rags.

Red After-Dyes

Madder dye may be used to the last drop. Wool, rags and cotton yarn may be dyed in it. It must boil and the goods will become a light brownish red. Cotton and linen dye very light and fade in the sun, but the color is very pretty and may be used for warp where white is not wanted. The after-dye may also be used as the foundation color for darker red and brown shades. A little dye-stuff may be saved for this.

Cochineal dye may be used until there is only the clear water left. The light red almost colorless dye makes pretty light tints for old pure wool, white dresses and blouses, and a large amount of woolen sweater yarn may be dyed light red in such liquid.

If salmon color is desired, a tin solution is added, and the clean dry goods is allowed to boil in the liquid $\frac{1}{4}$ to $\frac{1}{2}$ hr. The amount of tin solution is regulated by the weight of the goods. For 250 gr. goods use 50 to 100 gr. prepared clear yellow tin solution.

If a more bluish red is wanted, mordant the goods first in alum and then boil without the tin.

Madder and cochineal dyes may be mixed.

Blue After-Dyes

Indigo gives no after-dyes, as the goods always draws all the color into itself. In logwood dye, however, light gray blue after-dye is found.

Violet After-Dyes

The same is true of these dyes, as for the red after-dyes, where madder or cochineal has been used.

Green After-Dyes

Green after-dyes are not worth while using. They only give a dirty, undecided color.

Brown gray and black after-dyes will give lighter shades. The gray after-dyes may be quite dainty and pretty.

From black logwood after-dyes, gray blue is obtained.

Dyeing of Old Goods

If one wishes to dye old, faded goods, this must first be well washed and then boiled $\frac{1}{4}$ hr. in soda water (which must not be strong enough to injure the goods) so that as much of the original dye is removed as possible. Then rinse it well. After that handle as the white.

When old goods is to be dyed, a darker color than the original must be chosen. For success

a great deal depends on the foundation color, as the new must be dark enough to cover the old.

Only pale yellow or pink may be dyed yellow.

Pale yellow, pale violet, light gray, light brown, very pale green and red may be dyed red.

Pale yellow, pale green, violet, blue gray and light brown may be dyed blue. With ground pine and chickweed dyes, pretty blues may be obtained.

Blue and red may be dyed violet.

All other light colors may be dyed brown.

All colors, light or dark may be dyed black.

It must be understood that with re-dyeing, the new color, unless it is very light, will always have a tone of the old ground color.

Unless one knows what dyes were used originally, it is best to dye a sample especially if the goods be of value, as the result may prove to be a different color than the one planned for. The old color is dissolved, so to say, by the new, and forms an entirely new compound.

Bleaching of Woolen Goods

No matter how well woolen goods is washed and the fats removed, it will never be perfectly white. If one wishes chalk white yarn or woolen cloth, it must be bleached. A peculiar odor will be noticed from these goods if boiling water be poured over them.

In the bleaching of woolen goods sulphur is used. This bleaching may easily be done at home by using sulphur in a tightly closed room where damp woolen goods has been hung.

For bleaching, a large tight box or barrel with cover may be used. On one side, and quite near the floor, cut out a piece large enough to admit a fairly good sized iron kettle. The hole must be provided with a cover. At the top of the barrel or box, on the inside, strips of wood must be nailed on which the stick, holding the yarn, may be rested. Sometimes the wool is hung from a large spool or placed loosely in a net.

After the yarn has been thoroughly washed and rinsed it is allowed to dry enough so that the water does not drop from it. It must be evenly wet, without dry spots. It is hung in the barrel or box, and the top is well covered.

Glowing charcoal is placed in the iron kettle or dish. A handful of coarsely powdered sulphur is placed on the glowing coals and the opening is quickly closed.

There must be a large enough opening near the bottom to allow draft enough to burn the sulphur.

The yarn or other goods is left in the box or barrel about 12 hrs. If it is white enough, it is rinsed in cold water and dried. If not, bleach again. Care should be taken not to hang the goods too near the kettle.

It is not necessary to bleach woolen goods to be dyed with plants. As a rule it is not done, but if one does not object to the work, certain light, dainty colors become cleaner when bleached, but some are duller and not as pretty as when using the bleached yarn.

Hand Measures

- 25 gr. soda—1 handful.
- 100 gr. greensoap—1 heaping wood spoon.
- 25 gr. madder— 1 “ tablespoon.
- 20 gr. mulberry— 1 “ “
- 15 gr. logwood— 1 “ “
- 20 gr. cochineal— 1 “ “
- 8 gr. pulverized alum—1 heaping teaspoon.
- 8 gr. coarsely powdered cream of tartar—1 heaping tablespoon.
- 12 gr. coarsely powdered potassium chromate—1 heaping teaspoon.
- 10 gr. iron sulphate—1 heaping teaspoon.
- 10 gr. coarsely pounded copper sulphate—1 heaping teaspoon.
- 1 gr. oilum—5 drops.

INDEX

Abbreviations: (w. d.), working drawing; (ill.), illustration; (pat.), pattern; (dr.), draft.

- Adaptations of borders, 52
 Adaptations of patterns, 51
 After-dye liquids, 206
 After-dyes, yellow, 206; red, 206; blue, 207; violet, 207; green, 207
 Alternate method of treadling for rug weaving, 161
 Alternate method of warping with four threads, 16
- Beaming, 20
 Beams, for double weaving, (ill.), 164
 Big Diamond pattern, (dr.), 60; (pat.), 61
 Black Dyes, 205
 Bleaching woolen goods, 207
 Block Work pattern, 66
 Blooming Flower pattern, 78
 Blue Dyes, 191, 193
 Bobbin winder, 37
 Bonaparte's March pattern, 76
 Borders, 76
 Border weaving in double or Damask weave, 164; (dr.), 165
 Borders, adaptations of, 52
 Braddock's Defeat, 91
 Brown Dyes, 200, 203; after Dyes, 207
- Canvas, Danish pattern, 105
 Chariot Wheel pattern, 68
 Checked paper, 51
 Cloth Beam, 34
 Cloth, construction of, 8
 Colonial, patterns, 59; double weaves, 162
 Color, introducing of, 43
 Construction of plain cloth, 8
 Counterpane, 69, 84, 85
 Crosses, securing of, in warping 12
 Cross pattern, 93
 Curtain, 70, 84
- Damask weave, 151
 Damask weave Danish pattern, 165
 Danish and Norwegian patterns, 101
 Danish loom, 175; (w. d.), 176, 177
- Danish method of writing draft for double Damask weave, 165
 Danish patterns, 101
 Diagonal weave for eight-harness Damask weave, 157
 Diagonal weave in three-harness Swedish pattern, 114
 Dog Tracks pattern, 96
 Doors and Windows pattern, 87
 Double Bow Knot, (dr.), 94; (pat.), 95
 Double Chariot Wheel pattern, 88
 Double Snowball, (dr.), 63; (pat.), 64; adaptations, 64
 Double tie-up for double Damask weave, 164; Danish way of writing draft, 165
 Double weaving, 162; beams for, (ill.), 164
 Draft, Danish, 101; reading 59
 Dyeing old goods, 207
 Dyeing utensils, 183
 Dyes, yellow, 184; red, 185; blue, 191; green, 193; violet, 198; violet with cochineal, 198; brown, 200; gray, 203; black, 205
 Dyes and Dyeing, 183
- Eight-harness and eight-treadle Damask weave, 154
 Eight-harness Damask weave, 153
 Eight-harness Damask weave, Danish draft, 165
 Eight-harness Damask weave, diagonal, 157
 Eight-harness loom, 124
 Eight-harness Swedish pattern, 115
- Federal Knot pattern, (dr.), 79; (pat.), 80
 Fine threads, use of, 56
 Five-and-six-harness Danish pattern, 105
 Five-harness Swedish pattern, 113
 Foot Stool, textile and wood, 166; (w. d.), 167; (ill.), 168
 Formulae for dyeing, 184
 Four-harness cotton table mat, (dr.), 158; (pat.), 159
 Four-harness Danish pattern, 101
 Four-treadle loom, 118
 Four Wheels, 95
- Fox Trail pattern, 87
 Goose Eye Danish pattern, 104
 Governor's Garden pattern, 72; (dr.), 74
 Gray Dyes, 203, 205; after dyes, 207
 Green Dyes, 193, 198
 Guess Me pattern, 97
- Hand measures, 208
 Harness, 32
 Heddle frames, 116
 Heddle horses, 32: (w. d.), 33
 Heddle sticks, 26
 Heddle sticks, tying of, 33; (w. d.), 34, 48
 Heddles, threading of, 27
 Heddles, knotting of, 25
 Heddles, wire, 116
 Holding the warp, 23
 Honey Comb Swedish weave, 110
- Indiana Frame Rose pattern, 90
 Introducing color, 43
 Irish Chain pattern, 82
 Irregular threading in Swedish patterns, 110
- Keeping account of threads warped, 16
 King's Flower pattern, 92
 Knotting the heddles, 25
- Lambs, 57
 Laying in sticks, 24
 Lease, 10
 Lease rods, 25
 Leopard Skin pattern, 86
 Linen draft, 157
 Longitudinal threads, 8
 Long warp, preparing of, 10
 Loom, parts of, 9: (ill.), 21
 Loom, power, 7
 Loom, simple hand, 9
 Loom, threading of, 26
 Loom, tying of, 31
 Loom, eight-harness, 124
 Loom, four-treadle, 118
 Loom, six-harness, 121
 Loom, six-treadle, 105

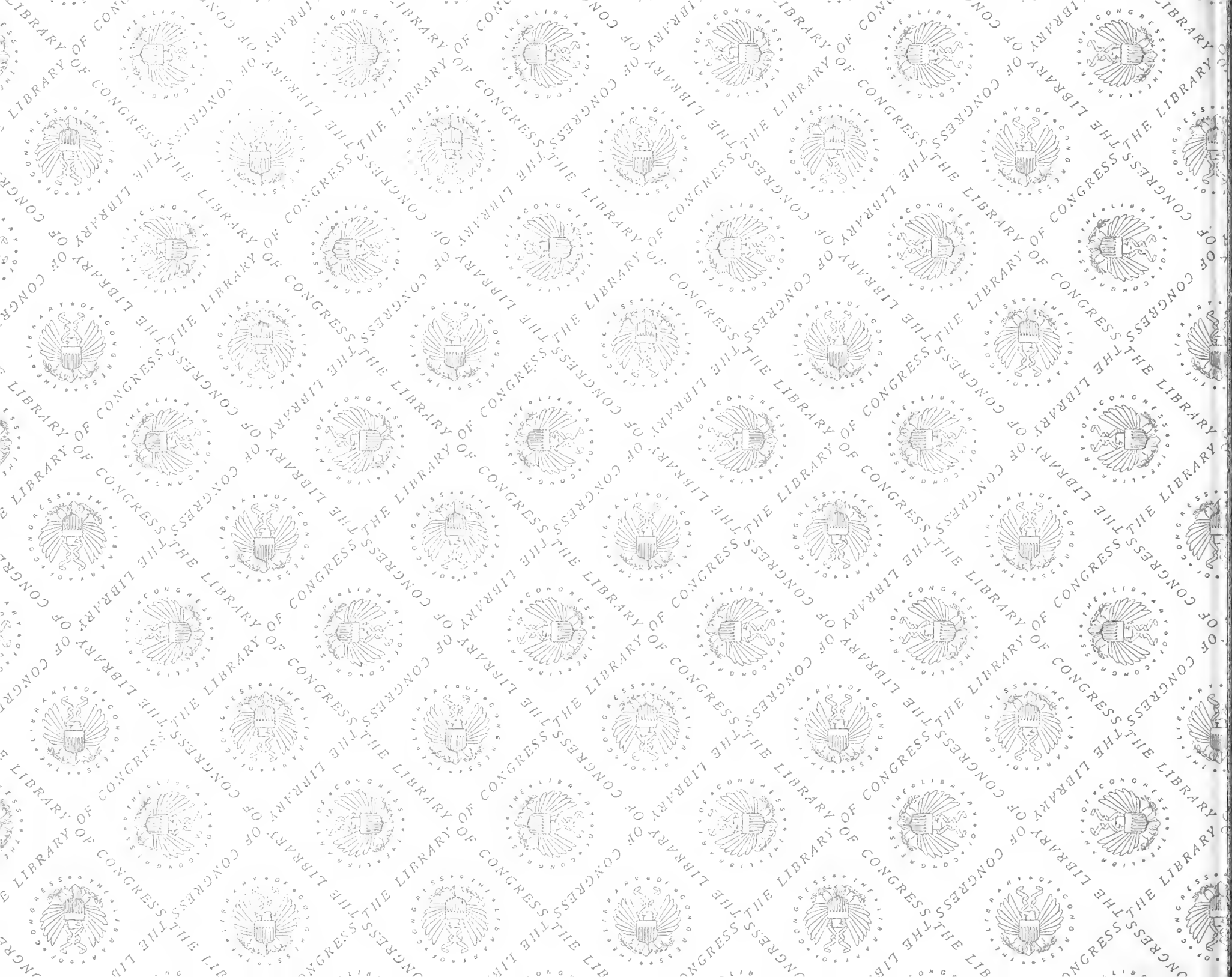
- Looms, 175
 Looms, Danish, 175; (w. d.), 176, 177, 178
 Looms, Swedish, 179; (w. d.), 180, 181, 182
- Mordant, 184
- Nine Snowballs, 82
 Nine Wheels, 82
 Norwegian patterns, 106
- Old Irish Quilt pattern, 93
 Old Quilt pattern, 85; (dr.), 86
 Olium, 190
 Orange Peel pattern, 71; (dr.), 72
- Paddle, construction of warping, 17; (w. d.), 18
 Paddle, use of, 18
 Parson's Beauty pattern, 91
 Patterns, adaptations of, 51
 Patterns, Colonial, 59
 Big Diamond, (dr.), 60; (pat.), 61
 Block Work, 66
 Blooming Flower, 78
 Bonaparte's March, 76
 Braddock's Defeat, 91
 Chariot Wheel, 68
 Cross, 93
 Dog Tracks, 96
 Doors and Windows, 87
 Double Bow Knot, (dr.), 94; (pat.), 95
 Double Chariot Wheel, 88
 Double Snowball, (dr.), 63; (pat.), 64,
 adaptation 64
 Federal Knot, 80; (dr.), 79
 Four Wheels, 95
 Fox Trail, 87
 Guess Me, 97
 Governor's Garden, 72; (dr.), 74
 Indiana Frame Rose, 90
 Irish Chain, 82
 King's Flower, 92
 Leopard Skin, 86
 Old Irish Quilt, 93
 Old Quilt, 85; (dr.), 86
 Orange Peel, 71; (dr.), 72
 Parson's Beauty, 91
 Pine Knot, 79
 Platform, 97
 Queen's Delight, 92
- Rings and Chains, 83
 Rose Path, 53
 Scarlet Balls, 88
 Sea Star, 89
 Snail's Trail and Cat's Paw, 77
 Virginian Snowball, 96
 Wheel of Fortune, 81
 Whig Rose, 99; (dr.), 100
 White House, 89
 Wind Flower, (dr.), 98; (pat.), 99
 Window Sash, 90
- Patterns, Damask, 151
 Danish, draft, 165
 Danish draft, eight-harness, 165
 diagonal, eight-harness, 157
 eight-harness, 153
 eight-harness and eight-treadle, 154
 Sea Shell, 163; (dr.), 162
 ten-harness, 151
 rug, alternate stripes, 161
 rug, six-harness, 161
 table mat, 159; (dr.), 158
 table mat, four-harness, 159; (dr.), 158
- Patterns, Danish, 101
 Norwegian, 101
 canvas, 105
 five-and-six-harness, 105
 four-harness, 101
 Goose Eye, 105
 two-harness, 101
- Patterns, Norwegian, 106
- Patterns, Swedish, 107
 diagonal weave, three-harness, 114
 eight-harness, 115
 five-harness, 113
 Foot Stool, 166; (w. d.), 167; (ill.), 168
 four-harness threading, 108
 four-harness, 113
 Goose Eye, 112
 Honey Comb, 110
 Rose Path, 111
 six-harness, 113, 120
 six-treadle, threading, 108
 three-harness, 113
 tie-up with sets of lambs, 116
 tie-up for seven harnesses, 114
 two-harness, 107
 two-treadle or four-treadle draft, 107
 Textile and Wood, 166
- Pattern weaving, 44
 Pattern weaving, threading of, 46
 Pegs, 11
 Pillow Tops, 67, 68, 73, 75
 Pine Knot pattern, 79
 Placing beams for cotton and wool weaving, 163;
 (w. d.), 164
 Placing the reed, 30
 Plaids, weaving of, 44
 Platform pattern, 97
 Power loom, 7
 Preparing a long warp, 10
- Queen's Delight, 92
- Raddle 20; (w. d.), 22
 Rag Rugs, 43
 Reading a draft, 59; Danish, 101
 Red Dyes, 185, 190; after dyes, 206
 Reed hooks, 30
 Reed, the, 27
 Reed, threading of, 29, 47
 Reel, 16
 Reel, warping, 13; (w. d.), 14
 Reels, 42; (ill.), 40; (w. d.), 41
 Removing warp from reel, 17
 Rings and Chains pattern, 83
 Rose Path pattern, 53
 Rose Path Swedish pattern, 111
 Rug, wool, 159, 161
 six-harness pattern, 160
 Rugs, weaving of, 43
- Scarlet Balls pattern, 88
 Screen, textile and wood, 168; (w. d.), 171;
 (ill.), 172, 170; (w. d.), 173; (ill.), 174
 Sea Shell, (dr.), 162; (pat.), 163
 Sea Star pattern, 89
 Selvage, 47
 Sewing Basket, textile and wood, 170
 Shed, 35
 Shuttle, 36; (w. d.), 37
 Shuttle stick, 36
 Simple loom, 9
 Six-harness loom, 121
 Six-harness Sea Shell pattern, (dr.), 162; (pat.),
 163
 Six-harness Swedish pattern, 113, 120
 Six-harness wool rug pattern, 160

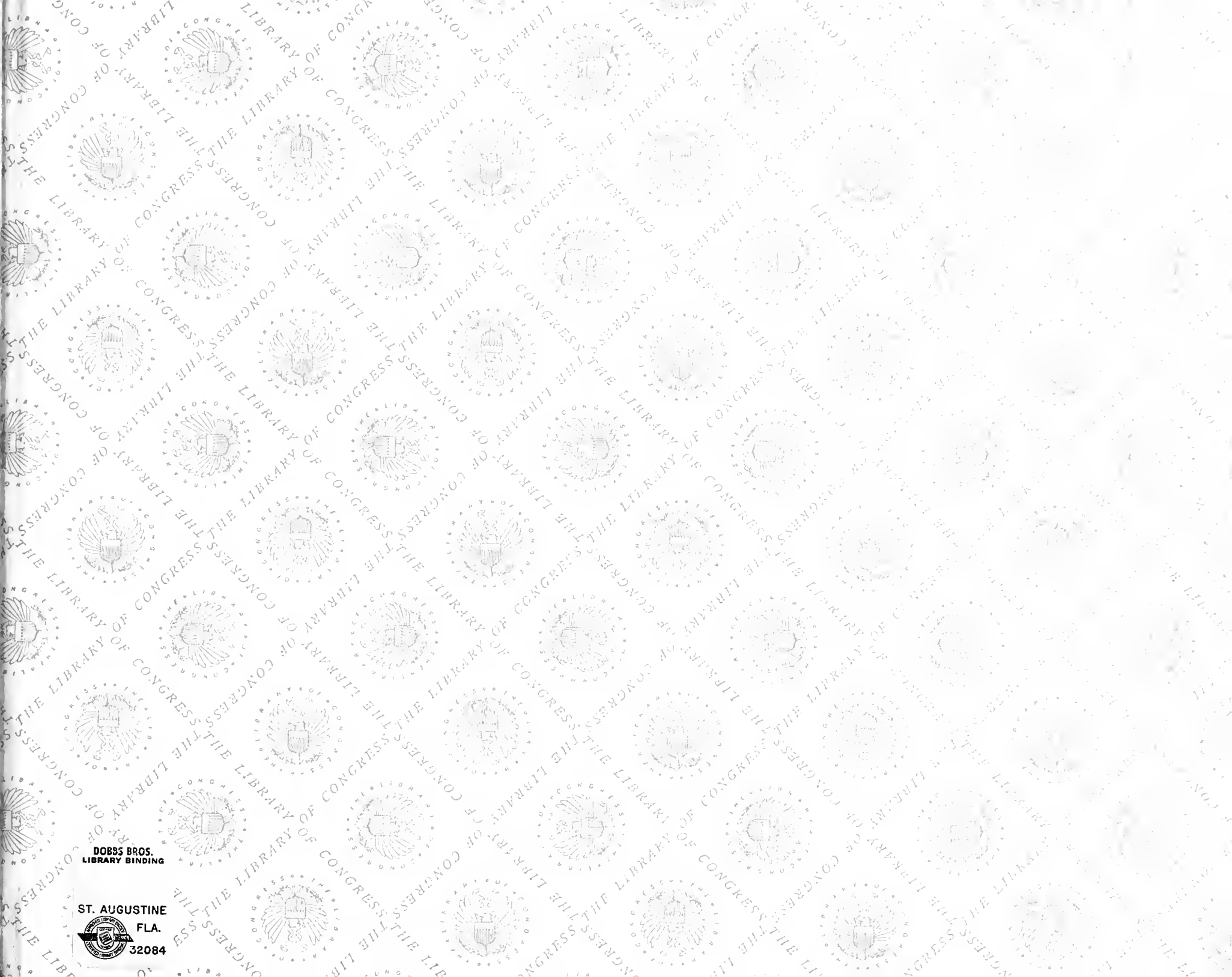
- Six-treadle loom, 105
 Snail's Trail and Cat's Paw Pattern, 77
 Spool rack, 15
 Starting threads on the reel, 15
 Swedish draft of Goose Eye pattern, 112
 Swedish loom, 178; (w. d.), 179, 180, 181, 182
 Swedish weaving, 107
 Stool, foot, 166; (w. d.), 167; (ill.), 168
 Table mat, cotton, (dr.), 158; (pat.), 159
 Table Runner, 65, 67
 Taking off the warp, 12
 Temple, 38; (w. d.), 39
 Ten-harness Damask weave, 151
 Textiles and Wood, 166
 Threading a four-harness Swedish pattern, 108
 Threading a six-treadle Swedish pattern, 108
 Threading a two-harness Swedish pattern, 107
 Threading damask weave, 152
 Threading for eight-harness double weave, 163
 Threading for pattern weaving, 46
 Threading for Rose Path pattern, 54
 Threading for ten-harness Damask weave, 156
 Threading the heddles, 27
 Threading the loom, 26
 Threading the reed, 29, 47
 Three-harness Swedish pattern, 113
 Three-harness Swedish pattern, diagonal weave, 114
 Tie-up damask weave, 152; eight-harness, 154; double weave, 164
 Tie-up for seven-harness Swedish weave, 114
 Tie-up pulley, 152
 Tie-up with sets of lambs, 116; double, 164
 Turning on, 20
 Two-harness Danish pattern, 101
 Two-harness Swedish pattern, 107
 Two-treadle or four-treadle Swedish draft, 107
 Tying heddle sticks for pattern weaving, 48
 Tying heddle sticks to treadles, 33; (w. d.), 34
 Tying the loom, 31
 Utensils, for dyeing, 183
 Upholstering, suggestions for, 166-168
 Violet Dyes, 198, 200; after dyes, 207
 Virginian Snowball, 96
 Warp, 8
 Warp, distribution of, 24; (ill.), 25
 Warp, holding of, 23
 Warp, removing from reel, 17; from board, 12
 Warp spreader, 20; (w. d.), 22
 Warp stand, 24
 Warp, taking off, 12
 Warping, alternate, 16
 Warping a number of threads at once, 16, 17
 Warping board, construction of, 10
 Warping board, use of, 11
 Warping reel, 13; (w. d.), 14
 Warping Threads, keeping count of, 16
 Waste Basket, textile and wood, 168; (ill.), 168; (w. d.), 169
 Weaving a border, 50
 Weaving a pattern, 49
 Weaving, double, 162
 Weaving of plaids, 44
 Weaving of rag rugs, 43
 Wheel of Fortune pattern, 81
 Whig Rose pattern, 99; (dr.), 100
 White House pattern, 89
 Wind Flower pattern, 99; (dr.), 98
 Window Sash pattern, 90
 Woof, 9
 Wool, washing of, 183
 Wood and Textiles, 166
 Yellow Dyes, 184, 185; after dyes, 206

RD 20.0









DOBBS BROS.
LIBRARY BINDING

ST. AUGUSTINE
FLA.



32084

LIBRARY OF CONGRESS



0 018 533 173 8