









THE CHEMISTRY AND TECHNOLOGY  
OF  
GELATIN AND GLUE



*McGraw-Hill Book Co. Inc.*

PUBLISHERS OF BOOKS FOR

Coal Age   ▽   Electric Railway Journal  
Electrical World   ▽   Engineering News-Record  
American Machinist   ▽   Ingeniería Internacional  
Engineering & Mining Journal   ▽   Power  
Chemical & Metallurgical Engineering  
Electrical Merchandising

UNIVERSITY OF  
TORONTO



### VENEERING AND THE USE OF GLUE IN ANCIENT EGYPT.

The upper cut shows, to the left, a piece of thin rare wood being applied to a plank of inferior quality. An adze is stuck into a block of the latter wood. Above this is a box made with inlaid veneer. The central figure is grinding something. Above him is shown a pot of glue being heated over a fire, and a piece of glue with its characteristic conchoidal fracture. The figure to the right is applying glue with a brush. The lower cut shows a plank of rare wood being cut into thin pieces for veneer. The figure to the right is smoothing the surface. Specimens of the wood showing its handsome grain are pictured at the left.

Wall carving in the tomb of Rekhmara in Thebes, Period of Thothmes III, 1500-2000 (?) B. C. Taken from "The Life of Rekhmara" by P. E. Newberry, Westminster, 1900. (Kindness of C. C. Keller of the Western Theological Seminary of Chicago, Ill.)



LIBRARY OF  
CALIFORNIA

THE CHEMISTRY AND TECHNOLOGY  
OF  
GELATIN AND GLUE

BY

ROBERT HERMAN BOGUE, M.S., PH.D.,

INDUSTRIAL FELLOW OF THE MELLON INSTITUTE OF INDUSTRIAL RESEARCH OF THE  
UNIVERSITY OF PITTSBURGH, AND RESEARCH CHEMIST FOR ARMOUR  
AND COMPANY OF CHICAGO

FIRST EDITION

McGRAW-HILL BOOK COMPANY, INC.

NEW YORK: 370 SEVENTH AVENUE

LONDON: 6 & 8 BOUVERIE ST., E. C. 4

1922

TO VMD  
ANNAPOLIS

TP965  
B6

COPYRIGHT, 1922, BY THE  
MCGRAW-HILL BOOK COMPANY, INC.

483570

THE MAPLE PRESS YORK PA

DEDICATED

TO

CHARLES FREDERICK CHANDLER,

The Patriarch of Chemical Progress in American Industry; than whom, among chemists, there is no one more beloved, no one more graced with kindly sympathy, and no one more potent to inspire, in all America.



## PREFACE

The dearth of reliable information upon the manufacture, testing, analysis, and general applications of gelatin and glue is felt keenly among students and investigators who are desirous of acquainting themselves with the principles of this industry. The books that are upon our shelves have not kept up with the latest developments and improvements in the art, and much information that is found in the literature is astonishingly inaccurate. But of even greater importance is the failure of previous writers to meet the issue of the *chemistry* of gelatin and glue. An enormous amount of very important and suggestive work has appeared during the past decade in the scientific literature dealing either directly or indirectly with the chemistry of gelatin, and it is in the correlation and summarization of this material that the author feels his work is most completely justified. The attempt is made throughout the book to attack the subject from the point of view of the chemist rather than from that of the plant technologist, and it is primarily for the student and investigator,—the thinkers ahead,—that the book is written.

There is no field of research that is more rich in highly interesting problems awaiting investigation than that of the protein colloids, of which gelatin and glue are the most conspicuous examples. We have but to point to the recent book by Wilder D. Bancroft on "Applied Colloid Chemistry," to cause a seemingly unending procession of such problems to rise before us and to beckon us on to master them. There is no dearth for study here. And it has been the constant aim of the present author to indicate lines upon which further investigation would be highly desirable.

The advance in the principles of industrial research that has been made during the past ten years is a seven-league stride when compared with the meager progress previously attained. Industrialists have been slow to appreciate the value of chemical research, and to those among them who have had the vision to foster it, too much credit cannot be given. The pioneer work of Armour and Company in providing for an intensive investiga-



tion upon gelatin and glue should be mentioned, together with the studies that are being carried on upon somewhat similar lines in the laboratories of A. F. Gallun and Sons, of Milwaukee, by John A. Wilson, and in the laboratories of the Eastman Kodak Company, of Rochester, by S. E. Sheppard.

The subject of gum and dextrin adhesives is omitted purposely on account of the unreliability of existing literature in this field. Work has been carried on upon this subject at the Institute, however, and it is the intention of the author to include the results of this study in a later edition. The subject of algal gelatins also has been omitted, but a brief résumé of that field may be found in *Chemical Age* (New York), **29** (1921), 485, by Irving A. Field.

The author wishes especially to express his thanks to Ralph C. Shuey, chemical engineer with the Redmanol Chemical Products Company, of Chicago, formerly with the Armour Glue Works, for his contribution of Chap. VI on "The Manufacture of Glue and Gelatin;" and to Dr. Donald K. Tressler, formerly industrial fellow of the Mellon Institute of Industrial Research, for his contribution of the section on "Liquid Fish Glues" (Chap. VII). The author also has made free use with proper credit of all available literature bearing upon the subjects treated.

It is a pleasure to acknowledge the indebtedness which the author feels towards Armour and Company for the cooperation, without which the present volume could not have been written. The constructive criticisms of J. R. Powell, chief chemist of the Armour Glue Works and of Adolph Heicke, the plant superintendent, have been of the greatest value. To William A. Hamor, assistant director of the Mellon Institute of Industrial Research, the author is indebted deeply for inspiration and encouragement, as also for editorial advice. It is an especial pleasure to be able to express the highest appreciation to Doctors John C. Hessler, Jacques Loeb, Wilder D. Bancroft, Martin H. Fischer, and Arthur W. Thomas for reading sections of the manuscript, and for their very valuable criticisms which have made possible an accurate and comprehensive treatment of the modern theories of the emulsoid colloids.

ROBERT HERMAN BOGUE.

PITTSBURGH, PA.,  
May, 1922.

# CONTENTS

	PAGE
PREFACE . . . . .	ix
INTRODUCTION.—Historical and Statistical Considerations. . . . .	1
PART I.—THEORETICAL ASPECTS	
CHAP.	
I. THE CONSTITUTION OF THE PROTEINS. . . . .	15
II. THE CHEMISTRY OF GELATIN AND ITS CONGENERS. . . . .	48
III. THE PHYSICO-CHEMICAL PROPERTIES AND STRUCTURE OF GELATIN	91
IV. GELATIN AS A LYOPHILIC COLLOID. . . . .	160
V. GELATIN AS AN AMPHOTERIC COLLOID . . . . .	219
PART II.—TECHNOLOGICAL ASPECTS	
VI. THE MANUFACTURE OF GLUE AND GELATIN, BY RALPH C. SHUEY	271
VII. WATER-RESISTANT GLUES AND GLUES OF MARINE ORIGIN. . . . .	318
VIII. THE TESTING OF GLUE AND GELATIN . . . . .	367
IX. THE CHEMICAL ANALYSIS, DETECTION, AND ESTIMATION OF GELATIN AND GLUE. . . . .	425
X. THE EVALUATION OF GLUE AND GELATIN. . . . .	487
XI. THE USES AND APPLICATIONS OF GLUE. . . . .	506
XII. THE USES AND APPLICATIONS OF GELATIN . . . . .	555
APPENDIX . . . . .	579
INDEX. . . . .	625



# THE CHEMISTRY AND TECHNOLOGY OF GELATIN AND GLUE

## INTRODUCTION

### HISTORICAL AND STATISTICAL CONSIDERATIONS

Glutinum ferunt Daedalium invenisse.  
Varro (about 20 B.C.)

The English word "gelatin"<sup>1</sup> is derived through the French *gélatine*, and Italian *gelatina*, from the Latin *gelata*, which means that which is frozen, congealed, or stiff. It is therefore, in origin, cognate with "jelly," which comes through the French *gêlee* from the same Latin original.

The term "glue"<sup>2</sup> comes through the French *glu* from the Latin *glutem* or *glus* meaning glue. The French also use the term *glu* to refer to *lime*, the name given to a viscous exudation of the holly tree, used for ensnaring birds and for that reason known as bird lime. The German word for glue, *leim*, comes through this source.

The term *glutin*, from the Latin *glutem*, is employed as the German equivalent of gelatin. This expression has also found occasional use by English writers in the designation of the pure protein "gelatin," as distinguished from the commercial material.

The Greek word for glue was κόλλα, from which the term "colloid" was derived directly, and meaning glue-like or gelatinous. The protein "collagen" was similarly derived from the same Greek term, with the ending *-gen*, the whole meaning a glue-producing material.

### HISTORICAL CONSIDERATIONS

The utilization of the skins of animals for protection against cold and in the forming of rough shelters was doubtless one of the earliest of the achievements of man in his evolution from his

<sup>1</sup> Used in 1800 by Hatschett (*Trans. Roy. Soc. London*, **90**, 366) as follows, "That animal jelly—which is distinguished by the name of gelatin."

<sup>2</sup> Used in 1400 by Lanfranc ("*Chirurgia Magna et Parva*," p. 135) as follows, "As it were two bordis weren ioyned togidere with cole or with glu."

progenital ape-like ancestors to the dawn of more enlightened civilization. A granite carving of ancient Egyptian origin which is probably 4,000 years old, and is now deposited in the British Museum, depicts the working up of a tiger skin to render it suitable for service. Homer (1000 B.C.?) wrote the picturesque lines descriptive of an ancient hide-preserving operation, in visualizing the struggle over the body of Patroclus:

“As when a man

A huge ox-hide drunken with slippery lard  
Gives to be stretched, his servants all around  
Disposed, just intervals between, the task  
Ply strenuous, and while many straining hard  
Extend it equal on all sides, it sweats  
The moisture out and drinks the unction in.”  
(Iliad, XVII, 389-393.)

That skins were used in the early Bible period is shown by many passages. In Kings (900 B.C.?), it is written:

“Dost thou see that I dwell in a house of cedar, and the Ark of  
God is lodged within skins.” (Kings, VII.)

Leather ornaments, straps, coverings, etc., have been found well preserved on mummies, and shoes of morocco leather of early Egyptian periods are existent.

Just how early it was discovered that a powerful adhesive could be made by cooking up hide pieces in water, cannot be ascertained, but it may be conjectured that such a discovery could not have been long delayed after the experiences obtained in the tanning and preservation of hides and pelts. Among the stone carvings of the ancient city of Thebes, of the period of Thothmes III, the Pharaoh of the Exodus, and at least 3,300 years old, is one representing the gluing of a thin piece of a rare wood of red color to a yellow plank of sycamore, see Frontispiece. A pot of the adhesive is being heated over a fire, and several samples of veneered and inlaid wood are pictured. One of the figures is spreading glue with a brush, and a piece of dry glue with its characteristic concave fracture is shown.

Reference is made to glue in the Bible in Ecclesiastes (200 B.C.):

“He that teacheth a fool is like one that glueth a potsherd  
together.” (Ecclesiastes, XXII, 7.)

It is probable that hide pieces only were employed for making glue in the earlier periods. At least no mention is made of the



use of bones for such a purpose until comparatively recent times, but reference is frequently made in the Roman period to the adhesive value of glue made from hides. Thus Lucretius about 50 B.C. wrote:

“Materials are made one from bullish glue,”

and Pliny, about a hundred years later repeated,

“Glue is cooked from the hides of bulls,”

and referred to a glue made in Rhodia as being most satisfactory:

“Rhodiacum glutinum fidelissimum.”

(Pliny 28, 17, 71, § 236.)

Varro (about 20 B.C.) advises us that glue was discovered in Daedalia,

“Glutinum ferunt Daedaliū invenisse,”

(Varro, from Charis, p. 67 and 106.)

but it was certainly in use before that period. Pliny refers to glue as being used, together with gums, milk, eggs, and wax as a vehicle for the paints used by the ancient Egyptians, and a glue-like material has been found in other ancient applications.

In the Elizabethian period (about 1600 A.D.) Shakespeare and Francis Bacon made frequent reference to glue. The adhesive value of the material is well attested in the lines of the great dramatist:

“Go to; have your lath glued within your sheath,

Till you know better how to handle it.”

(Titus Andronicus, Act 2, scene 1.)

And Bacon, in imitation of the earlier philosophers, discoursed as follows:

“Water and all liquors do hastily receive dry and terrestrial bodies proportionable; and dry bodies on the other hand drink in water and liquors, so that it was well said by the ancients, of earthy and watery substances, ‘One is glued to the other.’”

The earliest practical manufacture of glue that can be directly traced from the present day dates back to the time of William III of Holland. It appears to have been manufactured there in 1690, and shortly after to have been introduced into England and established as one of her permanent industries about 1700.

The first mention of glue in patent literature is found in a British patent of 1754, and refers to the preparation of “a kind of glue called fish glue.” This historic patent makes interesting reading.

A.D. 1754, May 23, No. 691. To Peter Zomer.

Making from the tails and fins of whales, and from such sediment, trash, and undissolved pieces of the fish as are usually thrown away as useless, after the boiling of the blubber, a sort of train oil, and afterwards making from the remains of such tails, fins, sediments, and undissolved pieces a kind of glue called fish glue.

For making the glue, the undissolved blubber and pieces of fish, after they have been boiled for the train oil, are put upon boards in a cold place or into small casks till they are perfectly cold and run together in one body which is then cut into small pieces and put into a trough made with a grate at the bottom, which must be then shut and the trough filled with water, in which these small pieces must lie about 24 hours in order to soak, after which the water is let off at the bottom through the grate, and these pieces are put into a boiler on the bottom whereof is laid first a wooden bottom with holes in it, over that a row of laths, and over them a covering of straw, and upon that a second row of laths, which must be fixed so as to prevent their swimming, and upon this the pieces are laid; water is added and the pieces and water are boiled together for 2 or 3 hours. Then any sediment remaining from former makings is put in and it is allowed to stand for 1 hour to settle. The glue water is then drawn off from the bottom of the boiler and afterwards the dross and sediment remaining in the boiler may be put into a press with holes in order to press out the remainder of the glue water. This glue water must be strained through a hair sieve to clear it, and then stand for a night in order to grow cold and stiff, when it is cut into pieces and placed upon nets to dry and harden.

The preparation of an isinglass made from "the internal and external gelatinous and membranous parts of fishes in general, and of the sturgeon in particular," was patented in 1760, and the system used today in Russia and some other countries in making isinglass was described in 1812.

In 1814 the treatment of bones with "muriatic, nitric, phosphoric, or acetous acid, and the mixture stirred daily until the bony, hard, or cartilaginous parts shall have become soft," was first mentioned in the patent literature. The use of steam under pressure "conveyed into a mass of bones in such manner as to extract therefrom a gelatin adapted for the purpose of glue" was first described in a patent of 1822. Sulphurous acid was introduced into glue and gelatin manufacture in 1838, and "euchlorine, chlorous, or chloric acid prepared from the chlorates or chlorides of lime, potass, soda, barytes, or other compounds by the action of hydrochloric or other acids," was described in 1839. Vacuo evaporation of glue liquors was introduced in 1844.

The first mention of the manufacture of a gelatin for edible purposes is found in a patent by Arney in 1846. He prepared a

powdered gelatin "for forming compositions from which may be prepared jellies and blanc-manges; also, when mixed with farina, or starch, or starchy vegetable flour, for thickening soups, gravies, etc."

The application of "currents of air artificially dried either by heat or any of the drying compounds in common use, such as concentrated sulphuric acid or fused chloride of calcium," was introduced in 1847. A few other important mechanical devices for speeding up the cooling of the product, for pulverizing, and for making a nearly anhydrous powdered glue have been added to the installment of the larger glue factories in recent years, but the operations today are otherwise not greatly different than those which were in practice 100 years ago. The modern glue manufacturing establishment is described in detail in Chap. VI.

The earliest official record of the United States government wherein glue is mentioned seems to have been in a compendium of all of the manufactures of the several counties of each state which was compiled for the year 1810. In this there were listed six establishments making glue in Pennsylvania, with a total product value for the year of \$53,206, and one in Maryland with a product value of \$500. In no other state is glue mentioned as being produced. The American Glue Co. of Boston affirm, however, that the originator of their company, Elijah Upton, began the first manufacture of glue in this country in 1808 in the town of Peabody, Mass., at that time called South Danvers. Peter Cooper established his glue factory in 1827 at Brooklyn, N. Y.

#### STATISTICAL CONSIDERATIONS

The manufacture of glue and gelatin in this country since 1810, and the most recent data available upon imports and exports, are given in the following tables, taken mainly from the Census Reports of the Department of Commerce and the Bulletins of the Bureau of Foreign and Domestic Commerce.<sup>1</sup>

In Table 1 and Fig. 1 is shown a comparison of the domestic production, the total imports, and the total exports of glue and gelatin for the years 1914 and 1919. The most striking feature observed here is the enormous increase in exports (about 380 per cent) and decrease in imports (about 510 per cent) which occurred in that 5-year period.

<sup>1</sup> Especially U. S. Bureau of Foreign & Domestic Comm., *Bull.* 82, 1919

Table 2 and Fig. 2 show the number of establishments employed in manufacturing glue or gelatin as their principal product, the capital invested, and the value of the product, for the census years from 1810 to 1914, and the distribution of manufacture among the several states in the latter year. It will be observed that the capital invested and the value of the product have quite steadily increased, whereas, the number of establishments has decreased since 1879 from 82 to 57. This means that the industry has become more centralized and that a large number of small factories has given place to a less number of larger ones. Illinois led in 1914 in the capital invested and the value of the product, although Massachusetts had a greater number of glue and gelatin establishments.

It is sometimes overlooked that glue and gelatin are also produced in large amounts by establishments that are devoted primarily to the manufacture of some other product. The slaughtering and meat packing establishments especially produce large amounts of glue and gelatin, but these are not included in Table 2.

Tables 3 and 4 are compiled to give data upon the relative amounts of glue manufactured in glue and in other establishments in 1900 and in 1914, and the relative amount of glue made from the several chief sources, as hides, bones, etc. see also Fig. 1. In 1900 there was very nearly as much glue made in slaughtering as in glue establishments, but in 1914 only 15.7 per cent of the value of the total output came from slaughter houses. From fertilizer establishments came 5.7 per cent, and 9.0 per cent from all others, as plants manufacturing sand and emery paper, tallow, soap stock, food preparations, oleo oil, and fish oil. More than 60 per cent of all glue (in 1900) was made from hide pieces, fleshings, sinews, leather cuttings, etc., and 33.5 per cent from bones. Fish skins and refuse contributed 4.3 per cent.

The imports of glue and gelatin, and glue stock, for the years 1914, 1918 and 1919 are shown in Tables 5 and 6, together with the percentage by quantity imported from each of the principal shipping countries. In 1918 the imports reached a very low value, but in 1919 had gained greatly. Even the latter values, however, are much below the prewar level of 1914.

The exports of domestic and of foreign glue for the years 1914, 1918 and 1919, together with the percentage by quantity shipped to the principal receiving countries are shown in Tables 7, 8 and



9. It is noticeable that in 1914 the exports of foreign made glue and gelatin exceeded those of the domestic product by about \$273,000, while in 1919, the exports of domestic product exceeded those of foreign manufacture by \$1,472,000.

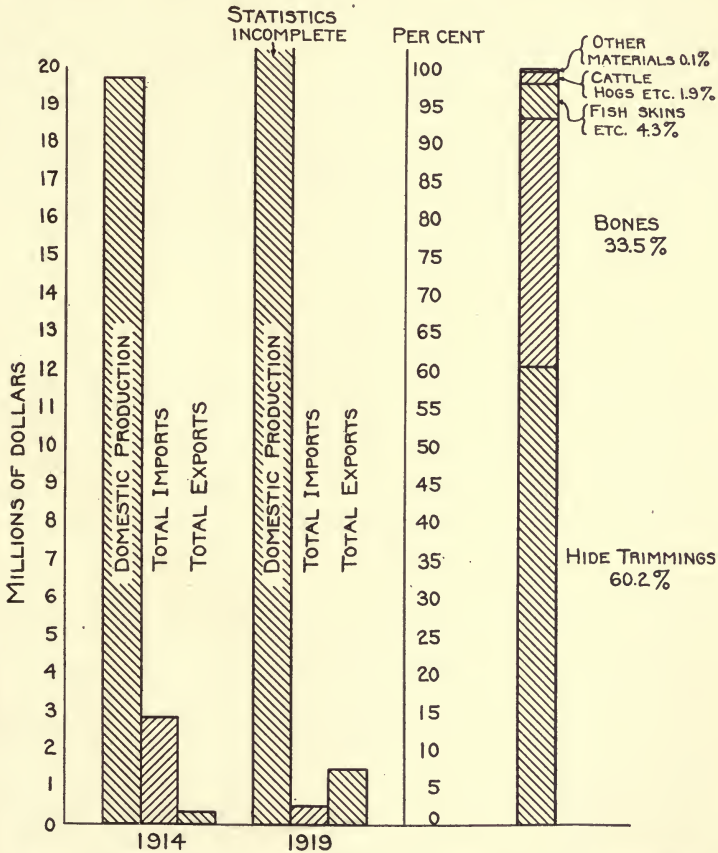

FIG. 1.—The domestic production, total imports, and total exports of glue and gelatin for the years 1914 and 1919. Distribution of glue manufactured from various materials in the United States in 1900.

A chart of the average prices of imported glue from 1820 to 1914 as compiled by Ludwig A. Thiele<sup>1</sup> is shown in Fig. 3. Considerable fluctuation will be observed within short periods of time, but the general tendency is shown to be a slight decrease of about 1 cent per pound each 15 years.

<sup>1</sup> LUDWIG A. THIELE, personal communication.



## GELATIN AND GLUE

TABLE 1.—DOMESTIC PRODUCTION, IMPORTS, AND EXPORTS OF GELATIN AND GLUE, 1914 AND 1919

1914			
Material	Domestic production	Total imports	Total exports
Gelatin, unmanufactured..	$\left\{ \begin{array}{l} \\ \\ \\ 19,725,703 \end{array} \right\}$	\$ 875,588	\$ 13,595
Glue.....		1,810,093	266,334
Mucilage.....		.....	26,182
Isinglass and fish glue.....		70,212	.....
Total.....	19,725,703	2,755,893	306,111
Hide cuttings and other glue stock.....	no data	1,510,608	.....
1919			
Gelatin, unmanufactured..	$\left\{ \begin{array}{l} \text{no data} \\ \\ \end{array} \right\}$	\$ 241,835	$\left\{ \begin{array}{l} \$1,489,625 \\ \\ 1,489,625 \end{array} \right\}$
Glue and size.....		208,882	
Total.....		450,717	
Hide cuttings and other glue stock.....	.....	978,514	.....

TABLE 2.—GLUE AND GELATIN MANUFACTURED IN THE UNITED STATES FROM 1810 TO 1914<sup>1</sup>

Year	Number of establishments	Capital	Value of product
1914	57	\$17,162,000	\$13,733,000
1909	65	14,289,000	13,718,000
1904	58	10,673,000	10,035,000
1899	61	6,144,000	5,389,000
1889	62	4,859,000	4,270,000
1879	82	3,917,000	4,324,000
1869	70	1,955,000	1,710,000
1859	62	1,053,000	1,186,000
1849	47	520,000	652,000
1810	7	.....	53,706

<sup>1</sup> From establishments engaged primarily in the manufacture of glue or gelatin.

Distribution by States for 1914

Illinois.....	9	5,552,170	3,731,375
Massachusetts.....	11	2,956,497	2,588,733
Pennsylvania.....	8	2,820,250	2,028,767
New York.....	9	2,459,102	2,483,254
Indiana.....	3	356,295	280,251
All others*.....	17	3,018,048	2,620,449
Canada (1918).....	11	816,420	1,465,163

\* Includes: Ohio, 5 establishments; California, 3; Wisconsin, 2; and 1 each in Connecticut, District of Columbia, Iowa, Kentucky, Maine, Maryland and New Hampshire.

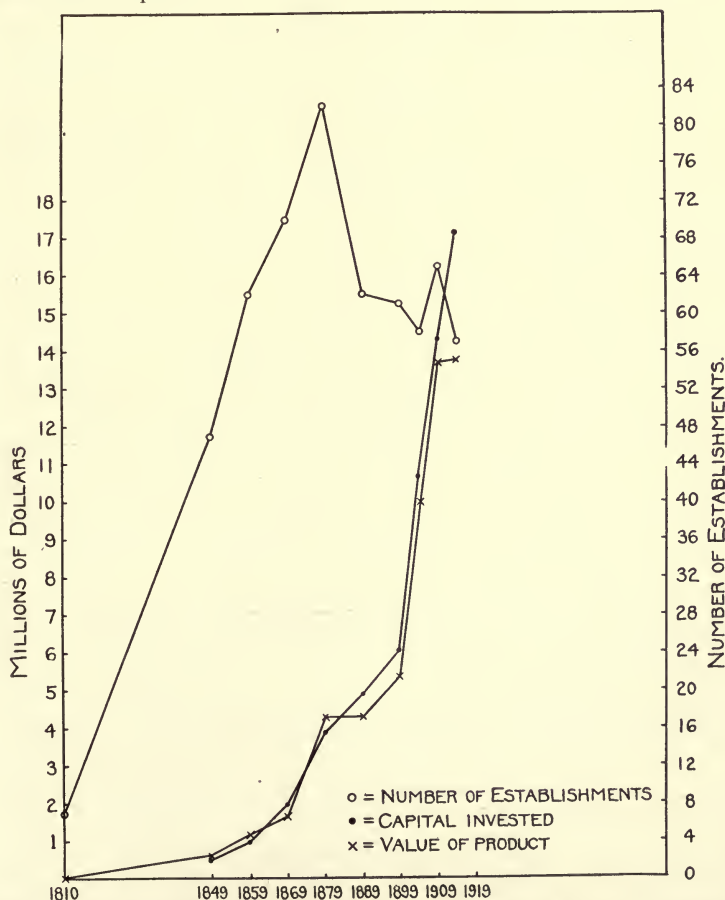

FIG. 2.—The glue and gelatin manufactured in the United States from 1810 to 1919.

TABLE 3. DISTRIBUTION OF GLUE MANUFACTURED IN GLUE ESTABLISHMENTS AND IN SLAUGHTERING ESTABLISHMENTS IN 1900

	Total pounds	Made from hide trimmings, etc.	Made from bones	Made from cattle, hogs, etc.	Made from fish skins and waste	Made from other materials
Glue establishments...	34,984,448	29,036,901	3,109,165	66,666	2,731,156	40,560
Slaughtering establishments.....	34,516,761	12,780,832	20,183,562	1,282,367	270,000	.....
United States.....	69,501,209	41,817,733	23,292,727	1,349,033	3,001,156	40,560
Percentage distribution, United States	100.0	60.2	33.5	1.9	4.3	0.1

TABLE 4.—VALUE OF GLUE MANUFACTURED IN GLUE AND OTHER ESTABLISHMENTS IN 1914

	Quantity, pounds	Value	Percentage by value from the different establishments
Glue establishments.....	40,844,650	\$13,732,824	69.6
Slaughtering establishments	} no data }	3,088,764	15.7
Fertilizer establishments....		1,131,243	5.7
All others (including sand and emery paper, tallow, soap stock, food preparations, oleo oil, and fish oil).		1,772,872	9.0
Total, United States.....	.....	19,725,703	100.0

TABLE 5.—IMPORTS OF GELATIN AND GLUE, 1918 AND 1919

Material	1918		1919		Percentage of quantity by Countries in 1919
	Pounds	Value	Pounds	Value	
Gelatin, unmanufactured.	82,766	32,353	449,336	241,835	Netherlands.. 72.5
					Scotland..... 16.7
					Switzerland... 5.3
					France..... 2.5
Glue and size.	732,324	172,642	866,042	208,882	Chili..... 28.9
					Netherlands.. 20.5
					France..... 18.5
					England..... 15.7
					Belgium..... 12.9
Hide cuttings and other glue stock.	9,381,629	454,838	13,780,637	978,514	Canada..... 40.7
					England..... 16.6
					Italy..... 12.1
					British India. 11.2
					Uruguay..... 8.7

TABLE 6.—IMPORTS OF GLUE AND GELATIN, 1914

Material	Quantity in pounds	Value in dollars	Percentage of quantity by countries in per cent
<b>Gelatin</b>			
Manufactured.....		135,374	Germany..... 41.0 France..... 37.6 England..... 17.6
Unmanufactured.....	2,441,337	738,731	Germany..... 55.9 France..... 21.7 Austria- Hungary..... 10.5 Switzerland.... 6.5 Scotland..... 4.2
Extra fine, gold label.....	1,489	481	Germany..... 100.0
No. 3, fine.....	1,669	1,002	England..... 84.9 Canada..... 14.4
<b>Glues</b>			
Animal glue.....	22,714,877	1,805,543	Germany..... 31.1 Austria- Hungary..... 23.9 England..... 19.1 France..... 12.2 Belgium..... 5.2
Glue powder.....	81,466	4,550	Germany..... 100.0
Isinglass and prepared fish sounds.....	147,438	56,454	Japan..... 90.1 England..... 3.9 Russia..... 3.1
Isinglass, lead.....	352	809	Russia..... 100.0
Marine glue pitch.....	300,273	13,758	Scotland..... 61.8 England..... 38.2
Hide cuttings and other glue stock.....		1,510,608	.....

TABLE 7.—EXPORTS OF DOMESTIC GELATIN AND GLUE, 1918 AND 1919

1918		1919		Percentage of quantity by countries in 1919
Pounds	Value	Pounds	Value	
5,809,605	\$1,110,837	8,486,167	\$1,480,777	Canada..... 29.8 England..... 17.9 China..... 8.6 Japan..... 6.8 Cuba..... 6.1 Denmark..... 6.0

TABLE 8.—EXPORTS OF FOREIGN GELATIN AND GLUE IN 1919

Material	Pounds	Value	Percentage of quantity by countries
Gelatin, unmanufactured...	2,635	\$1,187	Cuba..... 84.5
			Peru..... 12.5
			Canada..... 3.0
Glue and glue size.....	24,895	7,661	Canada..... 58.6
			Cuba..... 38.0
			Mexico..... 3.4

TABLE 9.—EXPORTS OF DOMESTIC AND FOREIGN GELATIN AND GLUE IN 1914

Material	Domestic product	Foreign product
Gelatin, unmanufactured...	.....	\$ 13,595
Glue.....	\$ 8,238	258,096
Mucilage.....	26,182	.....
Total.....	34,420	271,691

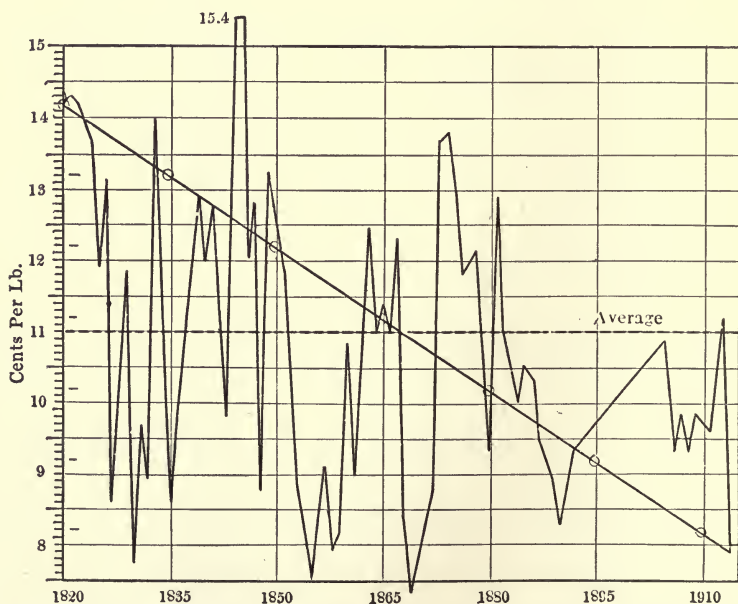

FIG. 3.—Average prices of imported glue from 1820 to 1914. (Kindness of Ludwig A. Thiele.)

**PART I**  
**THEORETICAL ASPECTS**

THE FIRST GREAT MISSION OF SCIENCE IS TO EXTEND THE  
BOUNDARIES OF KNOWLEDGE, THAT MAN MAY LIVE IN AN  
EVER-WIDENING HORIZON



# PART I—THEORETICAL ASPECTS

## CHAPTER I

### THE CONSTITUTION OF THE PROTEINS

It is the intuition of unity amid diversity  
which impels the mind to form a science.

F. S. Hoffman (about 1700 A.D.)

	PAGE
1. The Proteins.....	15
2. The Albuminoids or Sclero-proteins.....	19
3. The Cleavage Products of the Proteins.....	20
4. Determination of the Nitrogenous Constituents: Protein, Proteose, Peptone, and Amino-Acid.....	25
5. The Estimation of Amino-Acid.....	28
6. The Separation of the Amino-Acids.....	34
7. Determination of the "Hausmann" Numbers.....	37
8. Distribution of Nitrogen by the Method of Van Slyke.....	38
9. The Color Reactions of the Proteins.....	42

#### 1. THE PROTEINS

**General Description.**—Living matter has very succinctly been grouped into three great classes of compounds with respect to composition. The *carbohydrates* comprise the great bulk of plant life: the cellulose framework of the woody and fibrous portions; the starchy cells that fill the seeds with a reserve of energy; and the saps and fruit which are rich in sugars. The *fats* are less common in the greater portion of plant structures, but in certain forms, as the seed of corn, cotton, flax, soy-bean, etc., and in nuts of all varieties it is abundant. In animal economy the fats play a most important rôle. The *proteins* are by far the most complex, and probably more closely connected with the living processes than either of the other groups. The relative proportion of proteins in plants is usually very small. The legumes are an exception, as they are enabled by means of a saprophytic *azotobacter* in their roots to utilize nitrogen of the air in protein synthesis. Animals, however, are composed very largely of proteins. The flesh consists mainly of *myosinogen*, *para-myosinogen*, and *myosin*. The blood contains several pro-



teins, as *fibrinogen*, *fibrin*, *thrombin*, *serum globulin*, *pseudoglobulin*, and *serum albumin*. The skin, connective tissue, tendons, and bone contain *collagen*, *chondrigen*, *mucin*, and *elastin*. The hair, nails, horns, feathers etc., contain *keratin*. Milk contains *caseinogen*, *lactoglobulin*, and *lactalbumin*. Many other proteins are found in special glands or secretions of the animal body, but need not be enumerated.

When these several proteins are studied systematically, it soon becomes apparent that they are very unlike in many respects, although there may be found points of marked similarity. The word *protein* signifies "of first importance," and in respect to their rôle in the animal and plant economy they are well named and properly grouped. The processes most intimately bound up in what we call "life phenomena" are primarily concerned with activities of the protoplasm and body fluids, and these in turn are for the most part proteins. If the attempt is made to separate them from their source it is found that, while qualitative separations may easily be made, a quantitative separation is a most difficult if not impossible task. Many methods are commonly employed to obtain any specific protein in a state of high purity, but in the last few years these methods, such as coagulation by heat, precipitation by salts, solubility in weak acids or bases, etc., have been shown to be qualitative only.

Most of these methods of separation depend upon differences in solubility: not, as had formerly been propounded, upon profound differences in constitution or structure. This point is further substantiated by the fact that, unlike the saccharides, practically all proteins may be hydrolyzed by a single enzyme,—trypsin, and indeed most of them also by pepsin. In the case of the saccharides the active enzymes which will bring about hydrolysis are, in nearly every case, specific: that is, a given sugar will be acted upon by one enzyme only, and that enzyme will hydrolyze no other sugar. The various color-reactions of the proteins are also applicable to nearly all proteins. If the differences between them were profound it would be expected that they would require specific enzymes to accelerate hydrolysis, and that they would not all react to the same color tests.

Another peculiar property possessed by the proteins as a group is their ability to neutralize to a considerable extent the acidity of acids, or the alkalinity of bases, which may be added to them.

They therefore function as bases in neutralizing acids, and as acids in neutralizing bases. That is, they are amphoteric substances. The English physicist, Graham, found that the proteins would not diffuse through animal membranes or parchment paper. He, therefore, called them *colloids*, meaning *glue-like*, because glue, being also a protein substance, would not diffuse. This non-diffusibility of the proteins has in general been accepted as being due to the extraordinary size of the molecules, the pores of the membranes being so small that these large molecules are retained while the smaller molecules of the crystalloids may pass through easily.

In composition the proteins possess a very marked similarity. They all contain carbon, oxygen, hydrogen, and nitrogen, and sometimes sulphur and phosphorus. The average composition is approximately:<sup>1</sup>

Carbon.....	50.0 per cent
Oxygen.....	25.0 per cent
Hydrogen.....	7.0 per cent
Nitrogen.....	16.0 per cent.
Sulphur.....	0.3 per cent
Phosphorus.....	0.3 per cent

From the above consideration it is apparent that the proteins have many properties in common. They are always found in living matter, or produced by living matter, and are intimately associated with vital phenomena; they are separated quantitatively with great difficulty by applying the principles of fractional precipitation; nearly all are hydrolyzed by trypsin, and most of them by pepsin, into amino-acids which are simple and well defined substances; they all react to group color-tests; they are amphoteric substances, are colloidal, and are very similar in their ultimate chemical composition. To account for these several properties Kossel<sup>2</sup> in a study of the protamines established the hypothesis that the proteins consisted of a large number of amino-acid residues which were bound together through their carboxyl and amino groups. This theory was thoroughly substantiated by Emil Fischer<sup>3</sup> who succeeded in synthesizing

<sup>1</sup> MATHEWS, "Physiological Chemistry," 2nd. ed., New York (1916), 111.

<sup>2</sup> KOSSEL, *Z. physiol. Chem.*, **69** (1910), 138.

<sup>3</sup> EMIL FISCHER, "Untersuchungen über Aminosäuren, Polypeptide, und Proteine," Berlin (1906).

polypeptides having as many as eighteen amino-acids linked together as suggested by Kossel. This octadecapeptid, containing fifteen glycy radical and three leucyl radicals, possessed most of the properties of a natural protein.

**Classification.**—Two systems of classification of the proteins are in common use, one advanced by the American Society of Biochemists, the other by the English Society of Physiologists. As far as possible chemical differentiation has been made the basis of the grouping, but solubility differences are made use of in many cases.

The American classification recognizes three major divisions:

1. Simple proteins.
2. Conjugated proteins.
3. Derived proteins.

**I. Simple Proteins.**—These are naturally occurring proteins which on hydrolysis decompose only into  $\alpha$  amino-acids or their derivatives. They are grouped as follows:

- A. *Albumins.*—Simple proteins, coagulable by heat, soluble in water and dilute salt solutions. *Serum albumin.*
- B. *Globulins.*—Simple proteins, heat coagulable, insoluble in water, but soluble in dilute solution of salts of strong bases and acids. *Serum globulin.*
- C. *Glutelins.*—Simple proteins, heat coagulable, insoluble in water or dilute salt, but soluble in very dilute acids or alkalies. *Glutenin.*
- D. *Prolamines.*—Simple proteins, insoluble in water, soluble in 80 per cent alcohol. Found in grains. *Gliadin, zein.*
- E. *Albuminoids.*—Simple proteins, insoluble in dilute acids, alkali, water, or salt solution. *Collagen, gelatin, keratin, elastin.*
- F. *Histones.*—Simple proteins, not coagulable by heat, soluble in water and in dilute acid; strongly basic, and insoluble in ammonia. *Histone.*
- G. *Protamines.*—Simple proteins, strongly basic, non-coagulable by heat, soluble in ammonia, and yielding large amounts of diamino-acids on decomposition. *Salmin.*

**II. Conjugated Proteins.**—These are compounds of proteins with some other non-protein group. The other group is generally acid in nature. They are grouped as follows:

- A. *Hemoglobins* or *Chromoproteins.*—The prosthetic group is colored. *Hemoglobin.*
- B. *Glyco-* or *Gluco-proteins.*—The prosthetic group contains a carbohydrate radicle. In mucin and cartilage it may be chondroitic acid. *Mucin, mucoids.*
- C. *Phosphoproteins.*—Proteins of the cytoplasm. The prosthetic group

is not known, but it contains phosphoric acid, but not nucleic acid or a phospholipin. *Casein*.

D. *Neucleoproteins*.—Proteins of the nucleus. The chromatin. The prosthetic group is nucleic acid. *Nuclein*.

E. *Lecithoproteins*.—Found in the cytoplasm. Prosthetic group is lecithin or a phospholipin.

III. **Derived Proteins**.—This group includes all the decomposition products of the naturally occurring proteins, produced by any means whatsoever; and also the artificially synthesized polypeptids.

A. **PRIMARY PROTEIN DERIVATIVES**.

a. *Proteins*.—The first products of hydrolysis insoluble in water. *Edestan*.

b. *Metaproteins*.—Produced by further hydrolysis. Soluble in weak acids and alkalis, but insoluble in neutral solutions. *Acid albumin*.

c. *Coagulated Proteins*.—Insoluble protein products produced by the action of heat or alcohol.

B. **SECONDARY PROTEIN DERIVATIVES**.

a. *Proteoses*.—Hydrolytic decomposition products of proteins. Soluble in water, not coagulable by heat, precipitated by saturating their solutions with ammonium sulphate.

b. *Peptones*.—Produced by further hydrolysis. Soluble in water, not coagulable by heat, not precipitated by saturation with ammonium sulphate; generally diffusible, and giving the biuret reaction.

c. *Peptids*.—Compounds of amino-acids of which the composition is known.

The English classification is very similar. From the fact that the proteins of the Albuminoid group, *e.g.* collagen (from hides and bones), keratin, (from hair, horn, hoofs, feathers etc.), and elastin (from tendons) make up in large measure the organic part of the skeletal structure of animals, the English Society has called this group the *sclero-proteins*. It is at once apparent that it is with this group that the investigator of gelatin and glue is most concerned. Following the presentation of this brief introduction upon proteins in general, attention will, therefore, be focused throughout the rest of the chapter upon the albuminoid group, and its most interesting constituents.

## 2. THE ALBUMINOIDS OR SCLERO-PROTEINS

The proteins of the albuminoid group are, according to the customary classification, simple proteins, insoluble in dilute acid, alkali, salt solutions, or water. But while all of the members of



this group are insoluble in cold water, a few, *e.g.*, collagen, gelatin, and sericin are readily soluble in hot water after a preliminary soaking in cold water, during which period a solvation or hydration of the molecules takes place. Alexander<sup>1</sup> has suggested the following classification of the albuminoids, somewhat modified by the author:

- |   |   |
|---|---|
| <p>A. COLLAGENS: or Jelly-forming Albuminoids:<br/> <i>Collagen</i>; from bones, hides, etc., of animals,<br/>           and swimming bladders, skins, and scales of<br/>           fish.<br/> <i>Gelatin</i>; from collagen.<br/> <i>Sericin</i>; from silk.</p> | <p>Dissolved more or less readily by boiling water. The solutions gelatinize on cooling. Contain little or no sulphur.</p>                        |
| <p>B. FIBROIDS:<br/> <i>Elastin</i>; from elastic ligaments, tendons.<br/> <i>Fibroin</i>; from silk and spiders webs.</p>  | <p>Not acted on by boiling water or very dilute boiling alkali. Dissolved by stronger alkali. Unaffected by dilute acids. Contain no sulphur.</p> |
| <p>C. CHITINOIDS:<br/> <i>Chitin</i>; from external coatings of invertebrata.<br/> <i>Chonchiolin</i>; from shells of mollusca.<br/> <i>Spongin</i>; from sponges.</p>  | <p>Not acted on by boiling water or alkalies. Contain no sulphur.</p>   |
| <p>D. KERATINS:<br/> <i>Keratin</i>; from hoofs, horns, feathers, hair, etc.<br/> <i>Neurokeratin</i>; from brains.</p>   | <p>Not acted on by boiling water. Dissolved by boiling with dilute alkali hydroxide. Contain sulphur.</p>   |

### 3. THE CLEAVAGE PRODUCTS OF THE PROTEINS

Before consideration is given to the properties and reactions of the several individual proteins in the above group which are of interest to us, it is necessary to discuss the more general reactions, which are found to obtain with all proteins, upon treatment with certain enzymes and hydrolyzing agents. Whether we treat a protein with a solution of trypsin or pepsin in nearly neutral solution at ordinary temperature, or with a dilute acid or alkali at the boiling temperature, or with superheated steam, the results are the same in most practical respects. The complex colloidal protein molecule becomes broken into smaller and ever smaller segments. The largest of these derived proteins is called *proteose*, and in its properties most closely resembles the original protein.

<sup>1</sup> "Allen's Commercial Organic Analysis," 4th ed., vol. 8 (1913), 583.

As the cleavage is continued, and the segments become smaller, the properties likewise change regularly, and a second group is recognized, called *peptones*, which differs from proteose in much the same manner that proteose differs from protein. The final products of this hydrolysis, the *amino-acids*, are, however, very different from the original protein. They are definite chemical compounds of known constitution and structure, are crystallizable and non-colloidal, and of comparatively simple composition.

Nothing has aided the chemist in his search for an understanding of the true nature and constitution of the proteins as have these end products. It is very remarkable that of all of the proteins obtained from either plant or animal, all have been found to resolve upon hydrolytic decomposition into a very few simple amino-acids, twenty only having been isolated from proteins. It is believed with very good reason that the amino-acids are present in the protein molecule, a condensation being assumed between the carboxyl group of one and the amino group of a second. It makes no difference whether hydrolysis is brought about by an enzyme, by acid, by alkali, or by steam, the same amino-acids will ultimately be produced, and in the same proportion. It must be concluded, therefore, that the simple proteins are nothing more than condensation products of a few amino-acids, and that the differences observed in the several simple proteins is brought about by differences in the ratio and number of the several amino-acids represented.

**The Amino-acids.**—The composition and structure of the amino-acids which have been isolated from the proteins are as follows:<sup>1</sup>

*A. Monoamino monocarboxylic acids*

1. Glycine,  $C_2H_5NO_2$ , or amino acetic acid.  
 $CH_2 \cdot NH_2 \cdot COOH$
2. Alanine,  $C_3H_7NO_2$ , or  $\alpha$  amino propionic acid.  
 $CH_3 \cdot CHNH_2 \cdot COOH$
3. Valine,  $C_5H_{11}NO_2$ , or  $\alpha$  amino isovalerianic acid.  

$$\begin{array}{l} CH_3 \\ \diagdown \\ CH \cdot CHNH_2 \cdot COOH \\ \diagup \\ CH_3 \end{array}$$
4. Caprine,  $C_6H_{13}NO_2$ , or  $\alpha$  amino normal caproic acid.  
 $CH_3 \cdot CH_2 \cdot CH_2 \cdot CH_2 \cdot CHNH_2 \cdot COOH$
5. Leucine,  $C_6H_{13}NO_2$ , or  $\alpha$  amino isocaproic acid.

<sup>1</sup> Taken mainly from PLIMMER, "The Chemical Constitution of the Proteins," Pt. 1, 3rd ed., (London), (1917), 2-4.



6. Isoleucine,  $\text{C}_6\text{H}_{13}\text{NO}_2$ , or  $\alpha$  amino  $\beta$  methyl  $\beta$  ethyl propionic acid.

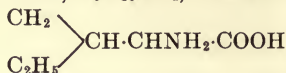

7. Phenylalanine,  $\text{C}_9\text{H}_{11}\text{NO}_2$  or  $\beta$  phenyl  $\alpha$  amino propionic acid.

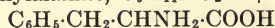

8. Tyrosine,  $\text{C}_9\text{H}_{11}\text{NO}_3$ , or  $\beta$  parahydroxyphenyl  $\alpha$  amino propionic acid.

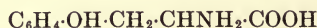

9. Serine,  $\text{C}_3\text{H}_7\text{NO}_3$ , or  $\beta$  hydroxy  $\alpha$  amino propionic acid.

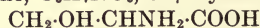

10. Cystine,  $\text{C}_6\text{H}_{12}\text{N}_2\text{O}_4\text{S}_2$ , or di ( $\beta$  thio  $\alpha$  amino propionic acid).

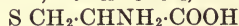

#### B. Monoamino dicarboxylic acids

11. Aspartic acid,  $\text{C}_4\text{H}_7\text{NO}_4$ , or amino succinic acid.



12. Glutamic acid,  $\text{C}_5\text{H}_9\text{NO}_4$ , or  $\alpha$  amino glutaric acid.

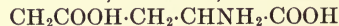

#### C. Diamino monocarboxylic acids

13. Arginine,  $\text{C}_6\text{H}_{14}\text{N}_4\text{O}_2$ , or  $\alpha$  amino  $\delta$  guanidine valerianic acid.

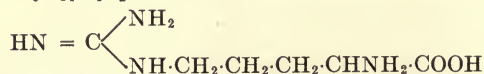
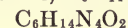

14. Lysine,  $\text{C}_6\text{H}_{14}\text{N}_2\text{O}_2$ , or  $\alpha - \epsilon$  diamino caproic acid.

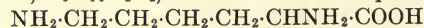

#### D. Heterocyclic compounds

15. Histidine,  $\text{C}_6\text{H}_9\text{N}_3\text{O}_2$ , or  $\beta$  imidazole  $\alpha$  amino propionic acid.

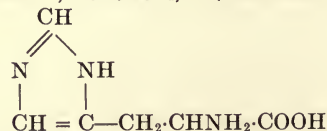

16. Proline,  $\text{C}_5\text{H}_9\text{NO}_2$ , or  $\alpha$  pyrrolidine carboxylic acid.

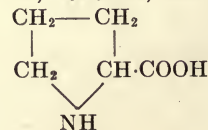

17. Oxyproline,  $C_5H_9NO_3$ , or  $\gamma$  hydroxy  $\alpha$  pyrrolidine carboxylic acid.

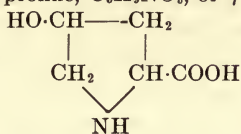

18. Tryptophane,  $C_{11}H_{12}N_2O_2$ , or  $\beta$  indole  $\alpha$  amino propionic acid.

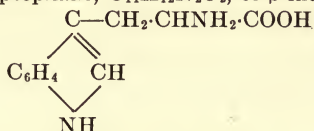

**The Proteoses and Peptones.**—Many intermediate products have been in one way or another separated between the proteose and peptone divisions. But it must be pointed out that although such a separation may be necessary in certain studies and produces data that are instructive, yet the differences between the several fractions are continuous functions of a solubility curve, and any permanent sub-division on such a basis seems unwarranted and unnecessary. Indeed Abderhalden<sup>1</sup> has even gone so far as to suggest that the term *proteose* be also dropped, and that all products intermediate between protein and amino-acids be termed *peptones*. His suggestion has not, however, been favorably received by the majority of biochemists.

The proteoses obtained from the different proteins differ greatly in their properties as is to be expected from a consideration of their varying origin, and of the varying complexity of their amino-acid content. For this reason many writers have used a nomenclature for the proteoses corresponding to the name of the protein from which it is derived. Thus the terms *albumose*, *gelatose*, *caseose*, *globulose*, *elastose*, etc., have found some service, but the general term *proteose* is in greatest favor. The terms *proto-*, *hetero-*, and *deutero-proteoses* have been used to designate varying degrees of solubility.

The *peptones* are more or less definitely defined chemical compounds. A great many have been made synthetically *in vitro*, especially by the master chemist Emil Fischer.<sup>2</sup> When peptones are prepared synthetically they are known as *poly-peptids*. Any combinations of two or more amino-acids are called *peptids*. Fischer obtained *hexa-*, *hepta-*, *octa-*, *dodeca-*, and

<sup>1</sup> OPPENHEIMER'S "Handb. der Biochem.," Bd. 1, (1908).

<sup>2</sup> EMIL FISCHER, *Op. cit.* See also PLIMMER, *lib. cit.*, part II.



even an *octadecapeptid* by means of reactions which enabled him to produce condensations between the carboxyl and amino groups of his original amino-acids. This process may be represented empirically as follows, with two molecules of glycine:

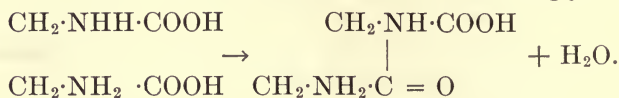

The first dipeptid known had this formula but was obtained from the anhydride of glycine by treatment with hydrochloric acid:

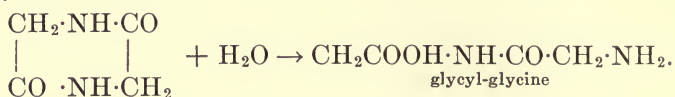

**Hydrolyzing Agents.**—*Proteoclastic*, or *protein-splitting enzymes* are found very widely distributed in both the animal and the plant world. *Pepsin* is excreted by the mucous membrane of the stomach of mammals, and *trypsin* is produced by the pancreas. *Erepsin*, of later discovery, is obtained from the mucous membrane of the small intestine. In addition to these, which are of greatest importance in digestive processes, proteoclastic enzymes have been isolated from nearly every organ of the body.<sup>1</sup> Similar enzymes may be found in many plants (*e.g.*, *papain* from the papaw tree). It is believed that a particular enzyme produces a scission only between certain particular types of linkage in the catenary molecule. For example if a racemic peptid is prepared synthetically and subjected to the action of an enzyme which will attack that peptid, it is observed that only that isomer which exists in nature is acted upon, whereas its asymmetric congener remains unaffected. For these reasons different proteins will be acted upon somewhat differently by the several proteoclastic enzymes.

Whenever it is desired to carefully and definitely control the process of hydrolysis, as in experiments upon digestion, an enzyme is used as the hydrolyzing agent, but if only the ultimate products, the amino-acids, are desired, the more rapid and drastic method of acid hydrolysis is resorted to. Hydrochloric acid of 20 per cent concentration is recommended by Van Slyke.<sup>2</sup> Sulphuric acid may also be used, but is more difficult to eliminate

<sup>1</sup> Cf. papers by Abderhalden and his pupils in recent volumes of *Z. physiol. Chem.*

<sup>2</sup> D. D. VAN SLYKE, *J. Biol. Chem.*, **10** (1911), 18.

after the hydrolysis is complete. With hydrochloric acid of this strength it requires from 12 to 60 hours at the boiling temperature, depending on the substance under investigation, to reduce the protein completely to amino-acids.

The hydrolysis of gelatin under different conditions of hydrogen or hydroxyl ion concentration, and by the use of different enzymes has been studied by Northrup.<sup>1</sup> He finds that if the hydrogen ion concentration is kept constant the hydrolysis follows the laws of a monomolecular reaction for a third of the reaction, but if not kept constant the hydrolysis is proportional to the square root of the time. The velocity is directly proportional to the hydrogen ion concentration when pH is greater than 10.0, but between these values is approximately constant and greater than would be calculated from the pH. Northrup accounts for this by assuming that the uncombined gelatin hydrolyzes much more rapidly than the gelatin salt. The particular peptid linkages that are most resistant to acid hydrolysis are the most rapidly split by pepsin, trypsin and alkali. All linkages that are attacked by pepsin are also hydrolyzed by trypsin (although with very different degrees of rapidity), but trypsin hydrolyzes linkages that are not attacked by pepsin.

#### 4. DETERMINATION OF THE NITROGENOUS CONSTITUENTS: PROTEIN, PROTEOSE, PEPTONE AND AMINO-ACID

By definition the proteoses consist of those nitrogenous cleavage products of protein which may be precipitated by saturation of the solution with the sulphate of ammonium, zinc, or magnesium. The unchanged protein is similarly precipitated by half saturation while the peptones are not thrown down at any concentration of the sulphates. It is an easy matter, therefore, to make such a separation in any mixture of protein cleavage products. Further separations by using concentrations of salt, varying by 10 or 15 per cent, between 20 and 100 per cent have been used in certain investigations, but are not in general necessary.

All precipitations by salt are best brought about in acid solution. Schryver<sup>2</sup> has recommended the addition of 2 c.c. of 1 to 4 sulphuric acid to each 100 c.c. of the sulphate solution and of the protein solution. In work upon gelatins the author<sup>3</sup>

<sup>1</sup> J. H. NORTHRUP, *J. Gen. Physiol.*, **3** (1921), 715; **4** (1921), 57.

<sup>2</sup> "Allen's Commercial Organic Analysis," 4th. ed., vol. 8 (1913), 482.

<sup>3</sup> R. H. BOGUE, *Chem. Met. Eng.*, **23** (1920), 106.

has shown that the maximum precipitation occurred upon the addition of only 0.5 c.c. of 1 to 4 sulphuric acid to each 100 c.c. of the reacting solutions. The influence of the addition of varying amounts of sulphuric acid is shown in Fig. 4.

Since the proportions of material thrown down at any given concentration of salt solution are continuous functions of a solubility curve it is evident also that variations in temperature

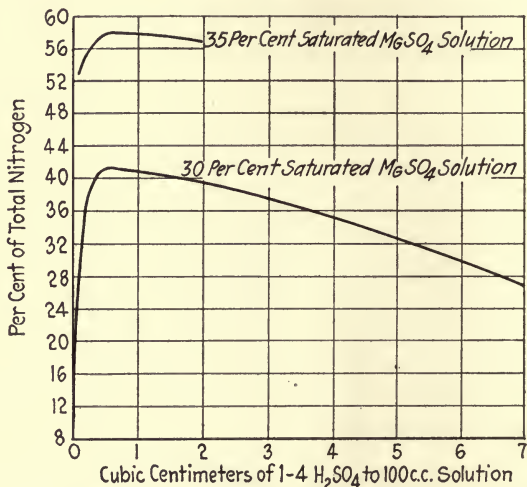

FIG. 4.—Effect of sulphuric acid on protein precipitation.

would be expected to alter greatly the proportions of precipitate obtained. In the case of gelatin the author found from 3 to 8 per cent more protein nitrogen thrown down at  $17^\circ$  than at  $25^\circ C$ . It is accordingly evident that where comparisons are desired between the nitrogenous substances precipitated from mixtures of protein cleavage products, it becomes necessary to work under carefully controlled temperature conditions.

The following procedure for the examination of a gelatin or glue has been found to give excellent results:<sup>1</sup>

1. The moisture is first determined.<sup>2</sup>
2. 10 g. (calculated on the water-free basis) are weighed out, dissolved in water, and made up to 500 c.c. in a volumetric flask.
3. A 50 c.c. aliquot is removed and total nitrogen determined by the Kjeldahl method.<sup>3</sup>
4. A 50 c.c. aliquot is removed into a 200 c.c. erlenmeyer flask, 0.3 c.c.

<sup>1</sup> For a further discussion of this determination see page 448.

<sup>2</sup> See page 429.

<sup>3</sup> See page 431.

of 1-4 sulphuric acid is added, and solid magnesium sulphate is then added in excess of the saturation point. The flask is stoppered and placed in a constant temperature room or bath (between 15° and 25°C.), and shaken frequently. After 24 hours it is filtered and washed with saturated magnesium sulphate solution containing 0.5 per cent 1-4 sulphuric acid. The filtrate and washings are retained for the amino-acid determination. The moist filter paper with its contents is removed to an 800 c.c. Kjeldahl flask and nitrogen determined in the usual way. The value so obtained represents the sum of the protein and the proteose nitrogen.

5. A 50 c.c. aliquot is removed as in No. 4, but in place of solid magnesium sulphate being added, 50 c.c. of a saturated solution of the same, containing 0.5 per cent 1-4 sulphuric acid, is added. This is treated as No. 4, except that the wash solution consists of half saturated magnesium sulphate with the usual acid content. The nitrogen value obtained represents the *protein* nitrogen.

6. The difference between Nos. 4 and 5 is the *proteose* nitrogen.

7. The combined filtrate and washings from the precipitation with saturated magnesium sulphate (No. 4) are used in the determination of the *amino-acids*. This may be done by the formaldehyde-titration method of Sørensen or by the nitrous acid method of Van Slyke.<sup>1</sup> If the former method is used the usual directions<sup>2</sup> have to be modified before they may be applied to the case in hand.<sup>3</sup> It is usually specified that both the formaldehyde and the solution containing the amino-acids should be made faintly pink to phenolphthalein before mixing. If these instructions are followed here, however, the solution resulting from the mixing becomes intensely red, making a determination impossible. The same thing happens with the control of saturated magnesium sulphate. The process should therefore be modified as follows: the amino-acid solutions and the control are made faintly pink to phenolphthalein. The formaldehyde is treated with sodium hydroxide until, on adding 25 c.c. of it to 100 c.c. of the control, the intensity of the original pink remains unchanged. A drop more of the base would produce an intensifying of the color; a drop less a decrease or removal of the color. The amino-acid solutions are then treated with the formaldehyde in the usual way, and titrated back to a uniform, rather deep, red with barium hydroxide in N/5 concentration.

8. The *peptone* is calculated by subtracting the sum of the protein, proteose, and amino-acid nitrogen from 100. A study of several different methods by the author shows an error for peptone by the above procedure of only 0.28 to 0.77 per cent.

A large number of glues and gelatins of all grades have been examined in the author's<sup>4</sup> laboratory by the procedure above described, and some extraordinarily illuminating results have been obtained. The grade (here referred to jelly consistency)

<sup>1</sup> These methods are described below.

<sup>2</sup> Cf. SCHRYVER, *loc. cit.*, p. 488.

<sup>3</sup> R. H. BOGUE, *loc. cit.*, p. 106.

<sup>4</sup> R. H. BOGUE, *loc. cit.*, 105.



was found to be in direct proportion to the percentage of the total nitrogen that was in the form of unhydrolyzed protein, or to the ratio of the protein nitrogen to the nitrogen representative of the products of protein hydrolysis. The proteose and peptone nitrogen varied inversely with the grade, while the actual amino-acid nitrogen was nearly constant, and very small.

Some of the data obtained are given in Table 10 and shown graphically in Figs. 5 and 6.

TABLE 10.—NITROGENOUS CONSTITUTION OF GLUES

	Grade <sup>1</sup>	Protein N	Proteose N	Peptone N	Amino-Acid N
Hide glues and fleshings...	H <sub>12</sub>	92.2	6.3	1.1	0.4
	H <sub>9</sub>	90.4	7.0	2.0	0.6
	H <sub>7</sub>	86.2	12.0	1.4	0.4
	H <sub>6</sub>	84.6	12.4	2.6	0.4
	H <sub>4</sub>	78.7	16.0	4.5	0.8
	H <sub>3</sub>	77.6	17.0	4.7	0.7
	H <sub>2</sub>	52.0	38.6	8.4	0.9
Bone glues.....	B <sub>7</sub>	79.1	14.9	4.8	1.2
	B <sub>6</sub>	73.5	16.4	8.1	2.0
	B <sub>5</sub>	64.6	28.3	5.6	1.5
	B <sub>4</sub>	59.8	32.4	6.4	1.4
	B <sub>3</sub>	53.6	36.6	8.4	1.4
	B <sub>3</sub>	52.5	37.9	7.8	1.8
	B <sub>2</sub>	48.2	40.1	10.1	1.6
	B <sub>1</sub>	36.8	47.1	12.5	2.3
B <sub>1</sub>	31.5	50.6	14.8	3.0	
Russian isinglass.....	H <sub>10</sub>	91.0	4.4	4.5	0.1
Edible gelatin.....	G <sub>8</sub>	87.8	11.3	0.7	0.2
Fish glue.....	B <sub>1</sub>	33.4	42.3	21.9	2.4
Pressure tankage.....	B <sub>1</sub>	34.3	46.4	16.3	3.0
Peptone.....	B <sub>1</sub>	0.0	33.2	48.5	18.3

<sup>1</sup> See page 503.

### 5. THE ESTIMATION OF AMINO-ACID

Two other methods which have found favor for following the course of an hydrolysis, or for determining the total amino-acids in a solution, are based upon the fact that as the large protein molecule is divided and broken up into smaller segments the

number of carboxyl and of amino groups increases. This is readily seen from the following illustration of the hydrolysis of glycyl glycine:

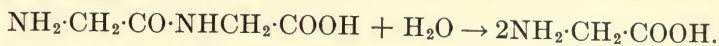

The original peptid had one carboxyl and one amino group. The

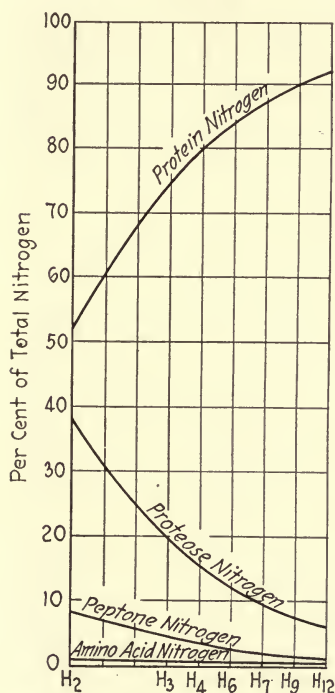

Grade in order of increasing jelly strength

FIG. 5.—Relation between nitrogenous constituents and jelly strength, hide glues.

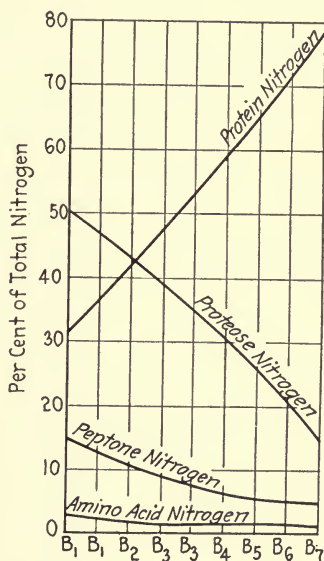

Grade in order of increasing jelly strength

FIG. 6.—Relation between nitrogenous constituents and jelly strength, bone glues.

two molecules of glycine resulting from the cleavage possess together two carboxyl groups and two amino groups. If the original peptid had, for example, ten amino-acids in combination, it would still have, as a peptid, only one carboxyl and amino group, but on complete hydrolysis it would possess ten each of these groups. If it were half hydrolyzed, *e.g.*, if five of the amino-acids were broken off and five remained combined there would be six each of the carboxyl and amino groups. In this way the course of an hydrolysis or digestion may be followed by measuring the groups mentioned.

**The Formaldehyde Titration.**—Sørensen<sup>1</sup> has developed a very workable method whereby the carboxyl groups may be determined. Owing to the amphoteric character of protein and all of its cleavage products including the amino-acids the acidity of these substances, which is developed through their carboxyl groups, may not be directly determined. Sørensen pointed out that the amino group, which is responsible for the basic properties of these substances, may be converted by formaldehyde into a neutral methylene imino group. After this has taken place the substance is no longer amphoteric, and may be titrated with an alkali in the usual manner. Again taking glycine as the simplest amino-acid, the reaction is expressed:

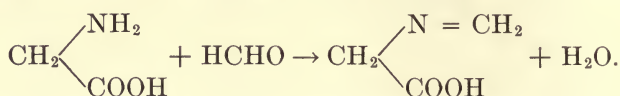

In practice the original solution and also the formaldehyde must be made as nearly neutral as is possible, the formaldehyde then added in excess, and the *increase* in acidity measured by N/5 barium hydroxide. If carbonates and phosphates are absent N/10 sodium hydroxide may be used. Each cubic centimeter of alkali added is then equivalent to 1.4 mg. of nitrogen existing as amino nitrogen.

**The Nitrous Acid Method.**—The quantitative estimation of amino-acid nitrogen by the decomposition of the latter with nitrous acid has been used by biological chemists for a great many years, but it is only since the technique has been highly perfected by D. D. Van Slyke<sup>2</sup> that very general usage has been made of the method. At present it is probably the best and most commonly used procedure. A complete determination may be made in about five minutes. The reaction involved is very simple:

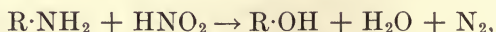

or using glycine as the amino-acid in question:

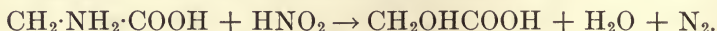

The amino-acid is converted into an hydroxy acid, which in this case is hydroxyacetic or glycolic acid. The requirement in the quantitative determination by this reaction is that the evolved

<sup>1</sup> SØRENSEN, *Biochem. Z.*, **7** (1908), 45.

<sup>2</sup> D. D. VAN SLYKE, *J. Biol. Chem.*, **9** (1911), 185; **12** (1912), 275; **16** (1913-14), 121; **23** (1915), 407.



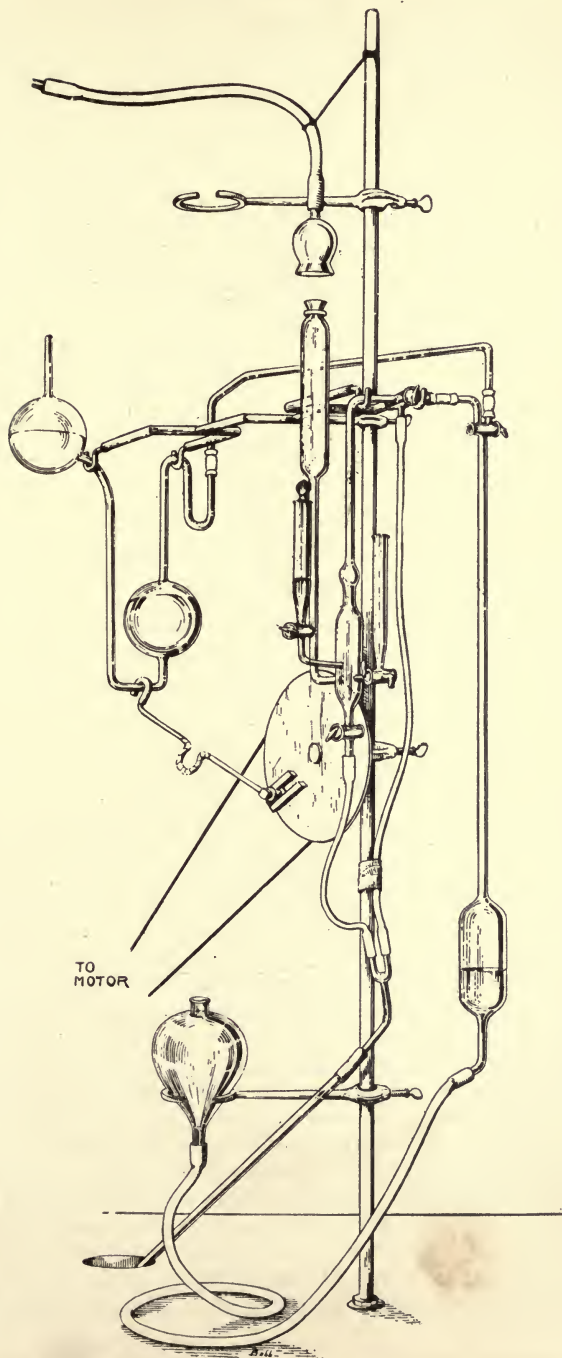
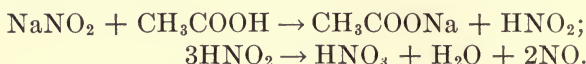
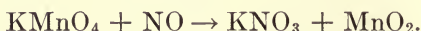

FIG. 7.—The Van Slyke amino-acid (micro) apparatus. (Kindness of D.D. Van Slyke.)

nitrogen gas be freed completely of any other gaseous impurities and measured accurately. Any traces of air, or of any other gas which may not be separated completely from the evolved nitrogen, which may be present in the apparatus will, of course, produce error. Nitric oxide is a gas which is absorbed readily by alkaline solutions of potassium permanganate. Use is made of this fact by replacing completely all air in the apparatus by nitric oxide, produced by the interaction of sodium nitrite and glacial acetic acid. Nitrous acid is produced which rapidly decomposes into nitric oxide and water:



The nitric oxide reduces the permanganate leaving manganese dioxide and potassium nitrate. The reaction representing the ultimate products may be written:



The nitric oxide is thus entirely absorbed, and only the nitrogen gas of the reaction remains to be measured.

The accompanying photograph and diagram, Figs. 7 and 8, taken from Van Slyke<sup>1</sup> show the appearance and *modus operandi* of the apparatus. There are three principal steps in the operation, (1) the displacement of the air by nitric oxide, (2) the decomposition of the amino substance, and (3) the absorption of the nitric oxide and measurement of the nitrogen.

**1. Displacement of Air by Nitric Oxide.**<sup>2</sup>—Water from *F* fills the capillary leading to the Hempel pipette and also the other capillary as far as *c*. Into *A* one pours a volume of glacial acetic acid sufficient to fill one-fifth of *D*. For convenience, *A* is etched with a mark to measure this amount. The acid is run into *D*, cock *e* being turned so as to let the air escape from *D*. Through *A* one now pours sodium nitrite solution (30 g.  $\text{NaNO}_2$  to 100 c.c.  $\text{H}_2\text{O}$ ) until *D* is full of solution and enough excess is present to rise a little above the cock into *A*. It is convenient to mark *A* for measuring off this amount also. The gas exit from *D* is now closed at *c*, and, *a* being open, *D* is shaken for a few seconds. The nitric oxide, which instantly collects, is let out at *c*, and the shaking repeated. The second crop of nitric oxide, which washes out the last portions of air, is let out at *c* also. *D* is now connected with the motor and shaken till all but 20 c.c. of the solution have been displaced by nitric oxide and driven back into *A*. A mark on *D* indicates the 20 c.c. point. One then closes *a* and turns *c* and *f* so that *D* and *F* are connected. The above manipulations require between 1 and 2 minutes.

<sup>1</sup> D. D. VAN SLYKE, *loc. cit.*, **12** (1912), 277-8.

<sup>2</sup> The following description is taken directly from VAN SLYKE, *loc. cit.*

**2. Decomposition of the Amino Substance.**—Of the amino solution to be analyzed 10 c.c. or less, as the case may be, are measured off in *B*. Any excess added above the mark can be run off through the overflow tube. The desired amount is then run into *D*, which is already connected with

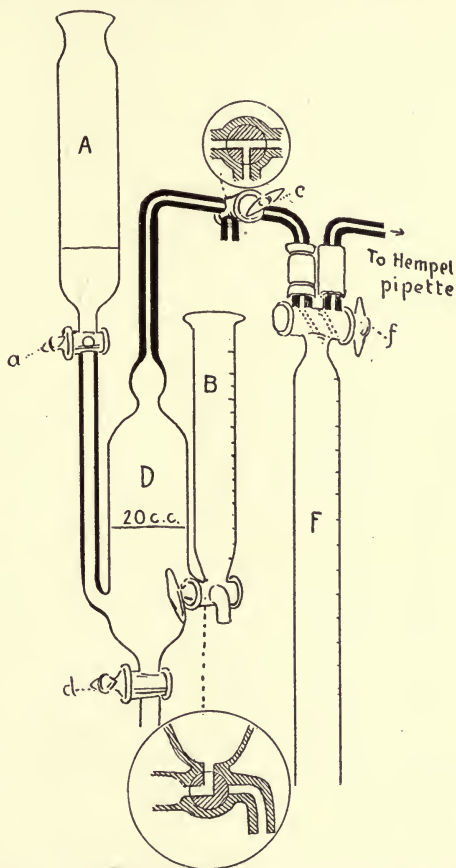

FIG. 8.—The deaminizing bulb and connections of the Van Slyke amino-acid apparatus. (Kindness of D. D. Van Slyke.)

the motor, as shown in the photograph. It is shaken, when  $\alpha$ -amino acids are being analyzed, for a period of 3 to 5 min. With  $\alpha$ -amino acids, proteins, or partially or completely hydrolyzed proteins, we find that at the most five minutes' vigorous shaking completes the reaction. Only in the cases of some native proteins which, when deaminized, form unwieldy coagula and mechanically interfere with the thorough agitation of the mixture, a longer time may be required. In case a viscous solution is being analyzed and the liquid threatens to foam over into *F*, *B* is rinsed out and a little caprylic alcohol is added through it. For amino substances, such

as amino-purines, requiring a longer time than five minutes to react, one merely mixes the reacting solutions and lets them stand the required length of time, then shakes about two minutes to drive the nitrogen completely out of solution.

**3. Absorption of Nitric Oxide and Measurement of Nitrogen.**—The reaction being completed, all the gas in *D* is displaced into *F* by liquid from *A* and the mixture of nitrogen and nitric oxide is driven from *F* into the absorption pipette. The driving rod is then connected with the pipette by lifting the hook from the shoulder of *d* and placing the other hook, on the opposite side of the driving rod, over the horizontal lower tube of the pipette. The latter is then shaken by the motor for a minute, which, with any but almost completely exhausted permanganate solutions, completes the absorption of nitric oxide. The pure nitrogen is then measured in *F*. During the above operations *a* is left open, to permit displacement of liquid from *D* as nitric oxide forms in *D*.

The permanganate solution is made up by dissolving 50 g. of potassium permanganate and 25 g. of potassium hydroxide in water, and making up to one liter.

Inasmuch as the final measurement by the above procedure is the volume of a gas, it is self-evident that the temperature and pressure must be carefully noted, and considered in calculating the results. A conversion table is prepared by Van Slyke<sup>1</sup> showing the milligrams of amino nitrogen corresponding to 1 c.c. of nitrogen gas at 11° to 30°C. and 728 to 772 mm. pressure. It must also be remembered that only the  $\alpha$ -amino nitrogen is acted on by nitrous acid. Thus in arginine  $\frac{3}{4}$  of the nitrogen is unacted upon by nitrous acid; in histidine  $\frac{2}{3}$ ; in triptophane  $\frac{1}{2}$ ; and in proline and oxyproline none of the nitrogen is set free by that reaction. This fact however makes possible a division of the total nitrogen into amino and non-amino nitrogen which is made use of by Van Slyke<sup>2</sup> in differentiating the several nitrogenous groups.

## 6. THE SEPARATION OF THE AMINO-ACIDS

The operation of separating the several amino-acids from a protein and from each other is a long and tedious process, and by no means satisfactory from a quantitative point of view. The most painstaking operations have, prior to the work of Dakin, left  $\frac{1}{3}$  to  $\frac{1}{2}$  of the molecule unaccounted for when analyzed in this way. For these reasons the attempt is not often made in routine procedures, and is resorted to only for some particular

<sup>1</sup> See *Appendix*, page 621.

<sup>2</sup> D. D. VAN SLYKE, *cit. sup.*



and exacting information which may not be obtained by other methods.

The principle underlying the process developed by Emil Fischer<sup>1</sup> consists in esterifying the products of a protein hydrolysis, and separating the esters by fractional distillation at very low pressures. Hydrolysis may be carried out in a 25 per cent solution of either sulphuric, hydrochloric or hydrofluoric acid. On eliminating the acid after 30 to 150 hrs., and concentrating *in vacuo*, cystine and tyrosine separate out if present in large amounts. On saturating with hydrogen chloride gas at 0°C. glutamic acid separates. Esterification is then brought about by dissolving the concentrate in absolute alcohol and saturating with hydrogen chloride gas, and evaporating. This process is repeated several times. Osborne and his co-workers<sup>2</sup> modified the process by using alcoholic hydrogen chloride and zinc chloride, and distilling alcoholic hydrogen chloride through the mixture at 110°. Glycine separates from the product at 0°. The esters are set free from their hydrochlorides by treatment with sodium hydroxide and ether at 0°, until the free acid is neutralized, and then with solid potassium carbonate until a pasty mass is formed. This process is repeated, and after drying with fused sodium sulphate and distilling off the ether, it is fractionally distilled. Pressures of from 10 mm. to 0.5 mm., and temperatures from 40 to 160°C. are commonly used. The fractions are then hydrolyzed with water or barium hydroxide and the individual amino-acids separated as far as possible by their characteristic reactions or solubilities.

Dakin<sup>3</sup> has shown in a series of most exacting investigations that butyl alcohol may be used to great advantage in the separations of certain amino-acids or amino-acid groups, and he has been able to isolate and identify the amino-acids of 91.31 per cent of the total nitrogen content of gelatin. The esterification procedure of Fischer was employed with some modifications following an extended extraction with the butyl, and sometimes propyl, alcohol.

The butyl alcohol extraction under ordinary pressure was found to remove readily the alanine, leucine, and phenylalanine, while the hydroxyproline and serine were extracted more slowly, and glycine only partially. By employing reduced pressures proline may be extracted without danger of secondary changes. The last traces of hydroxyproline are best removed with propyl alcohol. Aspartic and glutamic acids are not extracted by these alcohols.

<sup>1</sup> EMIL FISCHER, *Op. cit.*

<sup>2</sup> See OSBORNE and TELLOTON, *Am. J. Sci.*, **24** (1907), 194. Also OSBORNE and JONES, *ibid.*, **26** (1910), 212.

<sup>3</sup> H. D. DAKIN, *Biochem. J.*, **12** (1918), 290; **13** (1919), 398; *J. Biol. Chem.*, **44** (1920), 499.

TABLE 11.—PERCENTAGE OF AMINO-ACIDS ISOLATED FROM VARIOUS PROTEINS

	Gelatin <sup>1</sup>	Gelatin <sup>2</sup>	Gelatin <sup>3</sup>	Gelatin <sup>4</sup>	Elaascin <sup>5</sup>	Sericin <sup>3</sup>	Fibroin <sup>3</sup>	Keratin <sup>6</sup>	Caseinogen <sup>7</sup>	Serum <sup>8</sup> albumin	Serum <sup>9</sup> globulin	Gliadin <sup>10</sup> (wheat)	Zein <sup>10</sup> (maize)	Legumin <sup>11</sup> (cow pea)
Glycine.....	25.5	19.25	12.4	16.5	25.75	0.15	36.0	0.4	0	0	3.5	0.02	0	0.38
Alanine.....	8.7	3.0	0.6	0.8	6.6	5.0	21.0	1.2	0.9	2.7	2.2	2.00	9.79	2.08
Valine.....	0.0	.....	.....	1.0	1.0	.....	.....	5.7	1.0	.....	+	0.21	1.88	?
Leucine.....	7.1	6.75	9.2	2.1	21.1	.....	1.5	18.3	10.5	20.0	18.7	5.61	19.55	8.00
Serine.....	0.4	.....	.....	0.4	.....	6.6	1.6	0.7	0.23	0.6	.....	0.13	1.02	0.53
Aspartic acid.....	3.4	.....	1.2	0.6	+	.....	+	2.5	1.2	3.1	2.5	0.58	1.71	5.30
Glutamic acid.....	5.8	1.75	16.8	0.9	0.8	.....	.....	3.0	11.0	7.7	8.5	42.98	26.17	16.97
Cystine.....	.....	.....	.....	.....	.....	.....	.....	6.8	0.06	2.5	0.7	0.45	?	.....
Phenylalanine.....	1.4	.....	1.0	0.4	3.9	.....	1.5	3.0	3.2	3.1	3.8	2.35	6.55	3.75
Tyrosine.....	0.01	.....	.....	0	0.34	5.0	10.5	4.6	4.5	2.1	2.5	1.20	3.55	1.55
Proline.....	9.5	6.25	10.4	5.2	1.7	.....	+	3.6	3.1	1.0	2.8	7.06	9.04	3.22
Hydroxyproline.....	14.1	6.4	3.0	3.0	.....	.....	.....	.....	0.25	.....	.....	.....	.....	.....
Tryptophane.....	.....	.....	.....	0	.....	.....	.....	.....	1.5	+	+	+	0	+
Histidine.....	0.9	.....	0.4	0.4	.....	4.0	.....	.....	2.59	.....	.....	0.61	0.43	1.69
Arginine.....	8.2	.....	9.3	7.6	0.3	.....	1.0	2.3	4.84	.....	.....	3.16	1.55	11.71
Lysine.....	5.9	.....	6.0	2.8	.....	.....	+	.....	5.80	.....	.....	0	0	4.98
Ammonia.....	0.4	.....	0.4	0.4	.....	.....	.....	.....	.....	.....	.....	5.11	3.64	2.05
Total.....	91.31	.....	70.7	42.1	.....	.....	.....	.....	.....	.....	.....	.....	.....	.....

<sup>7</sup> ABBERHALDEN and FUNK, *ibid.*, **53** (1907), 16.

<sup>1</sup> H. D. DAKIN, *J. Biol. Chem.*, **44** (1920), 524.

<sup>2</sup> P. A. LEVENE and N. A. BEATTY, *Z. physiol. Chem.*, **49** (1906), 252.

<sup>3</sup> Z. H. SKRAUP and A. VON BIEHLER, *Monatsh. Chem.*, **30** (1909), 467.

<sup>4</sup> FISCHER, LEVENE and ANDERS, *Z. physiol. Chem.*, **35** (1902), 70.

<sup>5</sup> ABBERHALDEN, "Lehrbuch. der physiol. Chem." (1909).

<sup>6</sup> FISCHER and DÖRPPINGHAUS, *Z. physiol. Chem.*, **36** (1902), 402.

<sup>8</sup> ABBERHALDEN and FUNK, *ibid.*, **53** (1907), 16.

<sup>9</sup> ABBERHALDEN, *ibid.*, **37** (1903), 495.

<sup>10</sup> ABBERHALDEN, *ibid.*, **44** (1905), 17.

<sup>11</sup> OSBORNE and CLAPP, *Am. J. Physiol.*, **20** (1907), 477; 498.

<sup>12</sup> OSBORNE and HEYL, *ibid.*, **22** (1908), 362.



The absence of hydroxyglutamic acid, valine and isoleucine in gelatin was definitely established, but traces of tyrosine and small amounts of serine were always found, together with a significant amount of unidentified sulphur compounds. The figures for glycine, alanine, and hydroxyproline are very much higher than any previously recorded. The glutamic acid value given by Skraup and von Biehler is probably much too high, due presumably to contamination of the glutamic acid hydrochloride with glycine hydrochloride, and causing also the glycine value to be too low.

The results of four investigations upon the amino-acid analysis of gelatin are shown in Table 11, together with similar analyses upon other proteins both of plant and animal origin.

#### 7. DETERMINATION OF THE "HAUSMANN" NUMBERS

As was previously stated, the separation and determination of the individual amino-acids is attended with many difficulties, and is not quantitative. But there are groups of amino-acids, the individual members of which are very similar among themselves, that present marked differences in properties and reactions from other groups. Thus the diamino-acids are more basic than the monoamino-acids and so may be readily separated from the latter by precipitation with alkaloidal reagents. Humin (or melanin) and ammonia are produced in the hydrolysis of the protein and may easily be measured. The distribution of the total nitrogen among these four groups, the nitrogen being expressed as percentages of the total, are known as the "Hausmann" numbers, from its originator.<sup>1</sup>

The procedure requires the hydrolysis of about 1 g. of protein with 20 per cent hydrochloric acid for several hours. The completion of the hydrolysis is noted by a failure of the solution to give the biuret reaction. It is evaporated at reduced pressure at 40° to a few cubic centimeters, transferred with 350 c.c. of water to a distilling flask, a slight excess of a suspension of magnesium hydroxide added and about 100 c.c. distilled over *in vacuo* at 40°C. into standard N/10 sulphuric acid. On titrating with N/10 alkali the *ammonia* produced in the hydrolysis is determined. The residue is then filtered, washed with water, and the precipitate, together with the paper, treated for nitrogen by the Kjeldahl method.<sup>2</sup> The nitrogen so obtained is called *humin* or *melanin* nitrogen. The filtrate obtained from

<sup>1</sup> Cf. OSBORNE and HARRIS, *J. Am. Chem. Soc.*, **25** (1903), 323.

<sup>2</sup> See page 431.

filtering off the humin is evaporated to 100 c.c., acidified with 5 g. of sulphuric acid, and treated with 30 c.c. of phosphotungstic acid. (Made by dissolving 20 g. of phosphotungstic acid and 5 g. of sulphuric acid in 100 c.c. of water.) After standing 24 hrs. the precipitated bases are filtered and washed with a dilute solution of phosphotungstic acid (made by dissolving 2.5 g. of phosphotungstic acid and 5 g. of sulphuric acid in 100 c.c. of water). The precipitate and paper are transferred to a Kjeldahl flask and nitrogen determined in the usual way. The result is expressed as *basic nitrogen*. The difference between the sum of the percentages of the nitrogen of these three groups and 100 gives the percentage of *mono-amino nitrogen*.

A few "Hausmann" numbers are presented in the following table, reported by Schryver.<sup>1</sup>

TABLE 12.—HAUSMANN NUMBERS OF TYPICAL PROTEINS

	N (per cent)	Amine N	Mono-amino N	Basic N	Humin N
Egg albumin.....	15.51	8.64	68.13	21.27	1.87
Caseinogen.....	15.62	10.36	66.00	22.34	1.34
Salmine.....	.....	.....	.....	87.8	.....
Edestine.....	18.64	10.08	57.83	31.70	0.64
Glutenin.....	17.49	18.86	68.31	11.72	1.08
Gliadin.....	17.66	23.78	70.27	5.54	0.79
Gelatin.....	.....	1.61	62.56	35.83	

### 8. DISTRIBUTION OF NITROGEN BY THE METHOD OF VAN SLYKE

The principle of Hausmann has been extended by D. D. Van Slyke so that instead of four groups being determined, he obtains a nitrogen distribution among eight groups, and results obtained by his method are quantitative, readily duplicable, and of not especially difficult technique. The ammonia and melanin fractions are identical with those of Hausmann. The bases he separates into the four amino-acids which compose it. The filtrate from the bases he separates into (a) *amino-acids* containing only *primary amino nitrogen*, and (b) those which contain *non-amino nitrogen* in pyrolidine or indole ring combination. The *cystine* of the bases is estimated by a direct determination of the sulphur content, cystine being the only naturally occurring amino-acid containing sulphur. *Arginine* is found by decomposing the molecule by a drastic treatment with potassium hydroxide,

<sup>1</sup> "Allen's Commercial Organic Analysis," 4th ed., vol. 8 (1913), 82.

*ornithine* and *urea* being produced. The urea in turn breaks up into *ammonia* and *carbon dioxide*. The complete reaction may be written:—

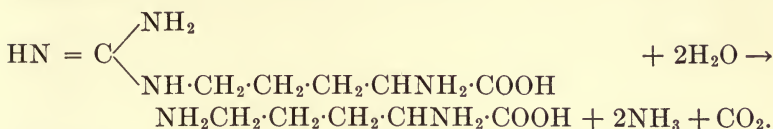

None of the other bases are attacked by this treatment. It was previously mentioned that not all of the nitrogen of the bases is amino nitrogen. The *amino nitrogen* is easily determined by the nitrous acid method of Van Slyke, and, by subtracting from the total nitrogen of the bases obtained by a Kjeldahl determination, the *non-amino nitrogen* is obtained. By an inspection of the formulas of the bases it will be seen that this non-amino nitrogen is derived from three-fourths of the *arginine* nitrogen, and from two-thirds of the *histidine* nitrogen. As the arginine and total non-amino nitrogen are known, the histidine nitrogen may easily be calculated. Letting A = arginine nitrogen, H = histidine nitrogen, and N = total non-amino nitrogen, then

$$\frac{3}{4}\text{A} + \frac{2}{3}\text{H} = \text{N}, \text{ or}$$

$$\text{H} = \frac{\text{N} - \frac{3}{4}\text{A}}{\frac{2}{3}} = \frac{3}{2}(\text{N} - \frac{3}{4}\text{A}) = 1.5\text{N} - 1.125\text{A}.$$

The remaining base, *lysine*, is calculated by subtracting the sum of the nitrogen of the other three bases from the total nitrogen of the bases.

The eight groups obtained by Van Slyke's distributions are therefore as follows:

1. *Ammonia*, or *amide nitrogen*, considered to be derived from  $-\text{CONH}_2$  or  $-\text{CONHOC}-$  groups linked to the carboxyl groups of the dicarboxylic acids in the protein molecule (glutamic and aspartic acids).

2. *Melanin*, or *humin nitrogen*, from the dark colored pigment and slight amount of insoluble matter always formed in the hydrolytic products of acid hydrolysis of proteins. It has been shown by Gortner and Blish<sup>1</sup> that "in all probability the humin nitrogen of protein hydrolysis has its origin in the tryptophane nucleus." They have found that when tryptophane was boiled with mineral acids in pure solution no humin was formed, but when tryptophane was added to a protein, or when carbohydrates

<sup>1</sup> R. A. GORTNER and M. BLISH, *J. Am. Chem. Soc.*, **37** (1915), 1630.

were present, an abundance of humin was formed. They recovered up to 90 per cent of the tryptophane nitrogen in the humin fraction.

3. *Cystine nitrogen.*

4. *Arginine nitrogen.*

5. *Histidine nitrogen.*

6. *Lysine nitrogen.*

7. *Amino nitrogen of the filtrate*, which corresponds to all of the monoamino-acids except proline and oxyproline.

8. *Non-amino nitrogen of the filtrate*, which corresponds to proline and oxyproline, and some of the tryptophane. (Of the tryptophane which is not retained in the humin fraction  $\frac{1}{2}$  will appear as amino and  $\frac{1}{2}$  as non-amino nitrogen of the filtrate. In exceptional cases a portion of the tryptophane may also be precipitated by the phosphotungstic acid, and be calculated as histidine and lysine.<sup>1</sup>)

Inasmuch as Van Slyke's method of studying proteins and their products of hydrolysis is so generally used and highly regarded where more exact studies of the individual amino-acids are not necessary, or would consume too much time in their estimation, a somewhat detailed description of the procedure is given below, which has been condensed from Van Slyke's original papers.<sup>2</sup>

From 1 to 3 g. of the proteins are boiled with 10 or 20 parts of 20 per cent hydrochloric acid under a reflux condenser until the hydrolysis is complete. This may take from 10 to 60 hrs. depending upon the protein used. The completion of the reaction is ascertained as follows: Portions of 1 or 2 c.c. of the mixture are withdrawn by a pipette at intervals of 6 to 8 hrs. and their amino-acid content determined by Van Slyke's method previously described. As soon as the amino-acid nitrogen becomes constant the hydrolysis is complete. The solution is then concentrated *in vacuo* until all of the hydrochloric acid possible has been driven off; the residue dissolved in a little water, and made up to 250 c.c. in a volumetric flask. Five cubic centimeter portions of this solution are used for the determination of total nitrogen by the Kjeldahl process.<sup>3</sup> Seventy-five cubic centimeter portions are removed into a Claissen flask, diluted to 200 c.c., 100 c.c. alcohol added, and about 50 c.c. (enough to produce a slight excess) of a 10 per cent suspension of calcium hydroxide introduced. About 100 c.c. are then distilled over at 50°C. and 30 mm. pressure into standard N/10 sulphuric acid, and the latter titrated back with N/10 alkali. This gives the *ammonia* or *amide nitrogen*.

<sup>1</sup> D. D. VAN SLYKE, *J. Biol. Chem.*, **10** (1911), 40.

<sup>2</sup> *Ibid.*, **10** (1911), 15-55; **22** (1915), 281-285.

<sup>3</sup> See page 431.



The residue is then filtered through a folded filter and washed with water till free of chlorides. The precipitate and paper are then subjected to a Kjeldahl analysis, using 35 c.c. of sulphuric acid to digest the large amount of organic matter of the filter. The nitrogen obtained represents the *humin* (or *melanin*) nitrogen.

After neutralizing the filtrate from the humin filtration with hydrochloric acid, it is concentrated *in vacuo* to 100 c.c. and removed to a 200 c.c. Erlenmeyer flask. Eighteen cubic centimeters of concentrated hydrochloric acid and 30 c.c. of a 50 per cent solution of phosphotungstic acid are added, the solution made up to 200 c.c. with water, and warmed on a water bath until the precipitate has practically all dissolved. It is then set aside for 48 hrs. The precipitate is best filtered through a hardened filter paper in a Buchner funnel, using suction. It is washed with a cold (0°C.) 2.5 per cent solution of phosphotungstic acid containing 3.5 per cent of hydrochloric acid, and stirred constantly with a glass rod to break up lumps. The precipitate of "bases" is transferred with 200 to 300 c.c. of water to a 500 c.c. separatory funnel, 5 or 10 c.c. of concentrated hydrochloric acid are added, and this followed by 100 c.c. of a mixture of equal parts of amyl alcohol and ether. After a few minutes shaking the precipitate is all dissolved and the amino-acids are found in the upper aqueous layer, while the phosphotungstic acid remains in the heavier layer below. Extraction of the aqueous layer is repeated to remove all of the phosphotungstic acid and finally evaporated *in vacuo* to dryness to remove all free hydrochloric acid. It is then dissolved in water and made up to 50 c.c. in a volumetric flask.

A 25 c.c. aliquot is removed for the *arginine* determination into a 200 c.c. Kjeldahl flask, and 12.5 g. of solid potassium hydroxide added. An upright condenser is connected to the flask, and the upper end of this sealed with a Folin bulb containing 15 c.c. of N/10 acid, colored with alizarin sulphonate. The solution is boiled gently for 6 hrs., then 100 c.c. of water are added and a like amount distilled over into the acid previously contained in the Folin bulb. On titrating the acid with standard N/10 alkali the arginine nitrogen is determined. If much cystine is present a correction must be applied, as 18 per cent of the cystine nitrogen is evolved as ammonia in the above process.

The residue from the arginine determination is treated by the Kjeldahl method for nitrogen. The value obtained when added to the arginine nitrogen gives the *total nitrogen of the bases*.

*Cystine* is found by decomposing 10 c.c. of the solution, by the Benedicts and Dennis<sup>1</sup> method of oxidation by ignition with copper nitrate. Five cubic centimeters of Dennis' solution (25 g. copper nitrate crystals, 25 g. sodium chloride, and 10 g. ammonium nitrate made up to 100 c.c.) are added in an evaporating dish to the 10 c.c. aliquot of the solution of the bases, evaporated to dryness on a water bath, and ignited at red heat for 10 min. The residue is dissolved in 10 c.c. of 10 per cent hydrochloric acid, diluted to 150 c.c., heated to boiling, and 10 c.c. of a 5 per cent solution of barium chloride added. The barium sulphate formed is treated and

<sup>1</sup> BENEDICT and DENNIS, *J. Biol. Chem.*, **6** (1909), 363; **8** (1910), 401.

weighed in the usual way. Each milligram of barium sulphate obtained indicates 0.06 mg. of cystine nitrogen in the portion of solution analyzed.

The *amino nitrogen in the bases* is determined by the nitrous acid method of Van Slyke, using 10 c.c. for the large apparatus, or 1 or 2 c.c. if the micro-apparatus is used.

*Histidine* and *Lysine* are calculated by the method that has already been described.

The filtrate and washings from the phosphotungstic precipitation of the bases are carefully neutralized and made slightly acid with acetic acid, concentrated under reduced pressure until crystallization begins, and made up to 150 to 250 c.c. in a volumetric flask. Twenty-five cubic centimeter portions are used for determining *total nitrogen of the filtrate* by the Kjeldahl method, and 10 c.c. portions are examined for *amino nitrogen* in the usual manner. The difference between the nitrogen obtained by these two processes gives the *non amino-nitrogen*.

Blank analyses should of course be made upon all chemicals used, and corrections should likewise be made for the solubilities of the bases in the solutions in which they are precipitated. These may be calculated from the following table prepared by Van Slyke:

TABLE 13.—SOLUBILITIES OF THE BASES IN 200 C.C. OF THE SOLUTION IN WHICH THEY ARE PRECIPITATED

	Total N (Add to the individual bases)	Amino N	Non-Amino N
Arginine N.....	0.0032	0.0008	0.0024
Histidine N.....	0.0038	0.0013	0.0025
Lysine N.....	0.0005	0.0005	0.0000
Cystine N.....	0.0026	0.0026	0.0000
Sum (subtracted from figures for filtrate.....)	.....	0.0052	0.0049

The results obtained from the examination of a number of proteins by the above described method of Van Slyke are given in Table 14, and curves showing the differences in constitution observed between hide glues, bone glues, fish glues, isinglass, and purified gelatin are shown in Figs. 9, 10, 11, and 12.

## 9. THE COLOR REACTIONS OF THE PROTEINS

The proteins yield many colored products upon the action of specific reagents, and in most cases these colored substances may be traced to the presence within the molecule of certain amino-



TABLE 14.—THE DISTRIBUTION OF NITROGEN IN PROTEINS (VAN SLYKE'S METHOD)

	Ammonia N	Melanin N	Cystine N	Arginine N	Histidine N	Lysine N	Amino N of filtrate	Non- amino N of filtrate	Total regained
Gliadin <sup>1</sup> .....	25.52	0.86	1.25	5.71	5.20	0.75	51.98	8.50	99.77
Edestin <sup>1</sup> .....	9.99	1.98	1.49	27.05	5.75	3.86	47.55	1.7	99.37
Hair (dog) <sup>1</sup> .....	10.05	7.42	6.60	15.33	3.48	5.37	47.5	3.1	98.85
Fibrin <sup>1</sup> .....	88.32	3.17	0.99	13.86	4.83	11.51	54.3	2.7	99.58
Hemocyanin <sup>1</sup> .....	5.95	1.65	0.80	15.73	13.23	8.49	51.3	3.8	100.95
Ox hemoglobin <sup>1</sup> .....	5.24	3.6	0 (?)	7.7	12.7	10.9	57.0	2.9	100.0
Gelatin <sup>1</sup> .....	2.25	0.7	0 (?)	14.70	4.48	6.32	56.3	14.9	99.02
Gelatin <sup>2</sup> .....	1.33	0.78	0	12.61	0.82	8.34	60.00	15.49	99.37
Hide glues <sup>2</sup> .....	2.90	0.59	0	13.90	2.19	7.97	56.84	15.63	100.02
Bone glues <sup>2</sup> .....	4.55	0.91	0	13.17	1.78	8.28	56.27	15.25	100.21
Isinglass <sup>2</sup> .....	3.98	0.68	0	14.20	2.33	6.06	58.65	13.59	99.49
Fish glue <sup>2</sup> .....	5.15	1.12	trace	13.80	2.04	8.58	60.20	9.66	100.55
Gliadin <sup>3</sup> .....	26.13	0.50	0.37	4.55	6.77	0.65	53.46	7.44	99.97
Glutenin <sup>3</sup> .....	16.50	1.84	0.18	9.69	5.47	2.61	53.59	9.52	99.40

<sup>1</sup> D. D. VAN SLYKE, *loc. cit.*

<sup>2</sup> R. H. BOGUE, *Chem. Met. Eng.*, **23** (1920), 156-157. The gelatin was four times precipitated from alcohol. The glue figures represent the average of all grades. The isinglass was the best quality of Russian staple.

<sup>3</sup> M. BLUSH, *J. Ind. Eng. Chem.*, **8** (1916), 151. (Obtained from a typical "strong" wheat flour.)

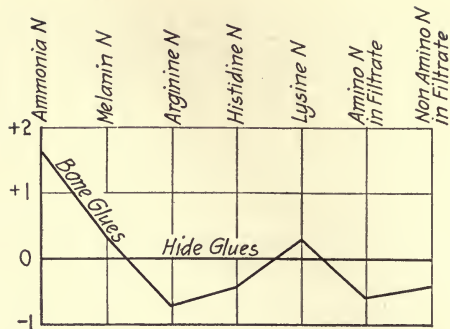

FIG. 9.—Variation in amino-acid constituents between the averages of the hide and bone glues.

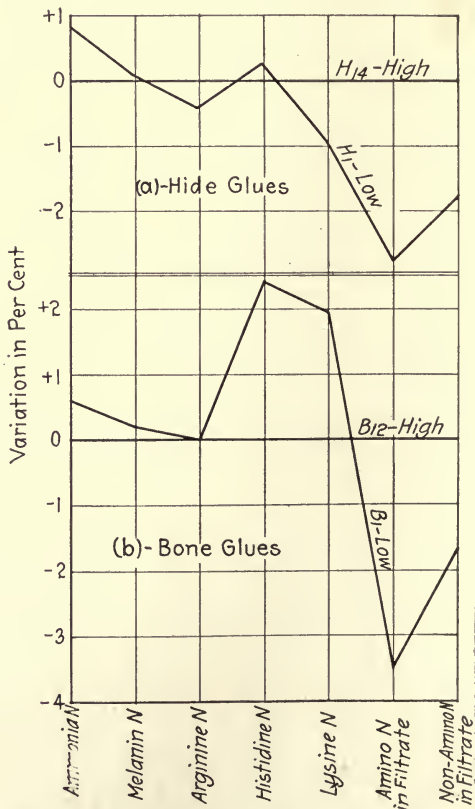

FIG. 10.—Variation in the amino-acid constituents on passing from the highest to the lowest grade glues.

acid groups. These tests are used, therefore, with a two-fold purpose, first, to detect the presence of protein or its decomposition products in any material, and, second, to establish a basis of opinion as to the presence or absence of certain amino-acid

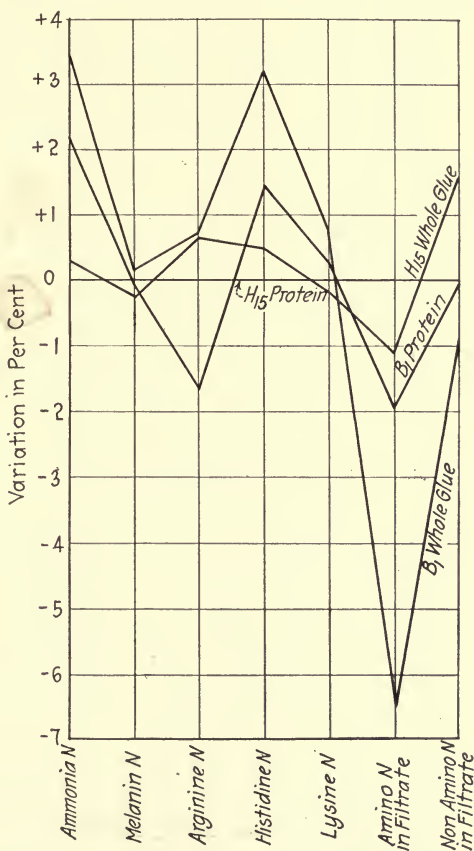

FIG. 11.—Variation in the amino-acid constituents between the highest hide glue protein (H<sub>15</sub>) and the protein of the lowest bone glue (B<sub>1</sub>). Whole glues shown also.

groups. Due to the great difficulties entailed in obtaining absolutely pure proteins, such tests cannot usually be taken as altogether conclusive evidence of the presence or absence of a particular group in a particular protein.

**The Biuret Reaction.**—The most generally used and universal test for proteins is the biuret reaction, as it reacts positive with all native proteins and with most of the proteoses and peptones,

The solution containing the protein is made alkaline with sodium or potassium hydroxide, and a few drops of a dilute solution of copper sulphate added, and well mixed. It may be allowed to stand at room temperature, or gently heated. The clear liquid

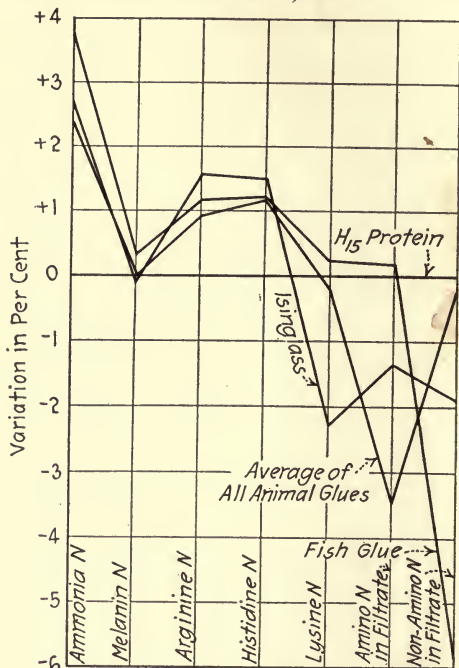

FIG. 12.—Variation, from the highest animal glue protein, of average animal glues, isinglass and fish glue.

is colored usually a violet, but may vary from a reddish to a bluish cast. The reaction was given its name from the fact that the test is also shown by biuret,  $\text{NH}_2\cdot\text{CO}\cdot\text{NH}\cdot\text{CO}\cdot\text{NH}_2$ .

The biuret test is unlike the other color tests for proteins in that it is not dependent upon the presence of a specific amino-acid, but rather upon a particular configuration in the molecule. The proteins react positive because they contain at least one acid amid group, and other substituted amid groups on adjacent carbon atoms.

**Millon's Reaction.**—When a protein is allowed to stand in contact with a mixture of mercuric nitrite and nitrate, or is heated with these substances, a red color is developed. The mixture of the mercuric salts is known as *Millon's reagent*. It is made by

dissolving 20 g. of mercury in 40 g. of concentrated nitric acid and, after solution is complete, diluting to 180 c.c. with water.

The test with Millon's reagent is specific for the monohydroxy benzene nucleus. It, therefore, reacts positive with many organic compounds other than proteins. The only amino-acid that has been observed in the decomposition products of the proteins that contains the monohydroxy benzene group is tyrosine. The reaction as applied to proteins is, therefore, specific for tyrosine. In the presence of alcohol or chlorides an excess of the reagent is necessary.

**Xanthoproteic Reaction.**—When proteins are heated with dilute nitric acid for a few minutes a yellow color is developed. On cooling and adding an alkali the yellow changes to a deep orange. The reaction is specific for the presence of the benzene nucleus in the molecule, which, with proteins, is confined to the three amino-acids tyrosine, phenylalanine, and tryptophane. The reaction depends upon the formation of a mono- or dinitrobenzene.

**Adamkiewicz Reaction.**—If a little glacial acetic acid or glyoxylic acid is added to a solution of a protein, and this followed by a small amount of concentrated sulphuric acid, a violet color develops in the mixture. The reaction appears to be specific for tryptophane. A modification of this test is used to detect the presence of formaldehyde in milk, the formaldehyde taking the place of the acetic or glyoxylic acid. The test is delicate in milk as casein is rich in tryptophane.

**Molisch's Reaction.**—A few drops of a 10 per cent alcoholic solution of  $\alpha$ -naphthol are added to a solution of a protein, and then a little concentrated sulphuric acid poured carefully down the side of the test tube. The development of a violet ring at the zone of contact indicates the presence of a carbohydrate group in the protein molecule.

**Sulphur Reaction.**—The protein is boiled with sodium hydroxide, during which process any sulphur that may be in the protein molecule will in part be split off as sodium sulphide. The presence of the sulphide is then observed by adding a little lead acetate to the tube, when a black or dark brown coloration or precipitate, depending on the amount of sulphur which was present, will be produced. As sulphur exists in the protein molecule only as cystine, the test is specific for that amino-acid.



## CHAPTER II

### THE CHEMISTRY OF GELATIN AND ITS CONGENERS

Glue is an organic combination presenting itself in different modifications.  
Dawidowski (1905).

	PAGE
I. The Proteins Associated with Gelatin.....	49
1. Collagen.....	49
2. Gelatin.....	52
3. Keratin.....	63
4. Elastin.....	67
5. Mucins and Mucoïds.....	69
6. Chondrigin and Chondrin.....	73
7. Melanins and Humins.....	74
8. Amyloid.....	76
9. Ichthylepidin.....	77
10. Comparison of the Properties of Gelatin and Its Congeners.....	78
II. The Tissues Containing Gelatin and Its Congeners.....	79
1. The Skin.....	79
2. The Connective Tissue.....	84
3. The Cartilage.....	86
4. The Bones.....	87
5. Fish Skins, Seales, Sounds, etc.....	88

If it is desired to appreciate not only the chemistry and physics of pure gelatin but also the behavior of the various commercial products known as gelatins and glues it becomes necessary that the other nitrogenous substances with which gelatin is commonly associated be understood. There seems to be, in fact, practically no tissue, with the possible exception of the inner membrane of fish sounds, that consists exclusively of collagen, the parent substance of gelatin, and gelatin *per se* is not found in the animal organism except under pathological conditions. Whether the material be obtained from the skin, sinews, bones, or fish parts, the collagen is found invariably associated with other protein material, as keratin, elastin, mucin, chondrin, etc., in addition to other non-protein organic material and inorganic salts.

In the process of extracting the gelatin it is inevitable that greater or lesser quantities of these undesirable proteins should become hydrolyzed and mix with the gelatin solution, the amount depending upon the conditions of temperature, pressure, hydrogen ion concentration, etc. It seems desirable therefore that



each of these proteins be described, and the combinations of proteins that occur in the tissues made use of in the manufacture of gelatin and glue be set forth.

## I. THE PROTEINS ASSOCIATED WITH GELATIN

**1. Collagen.**—In plant physiology the principal structural material producing turgor and rigidity is *cellulose*, a highly polymerized carbohydrate. In the animal a protein, often fortified by inorganic salts, serves in this capacity. Among the invertebrates the hard shell-like coverings are composed largely of a protein called *chitin*. In the vertebrates the protein material of the bones and of the several connective tissues is a mixture of several proteins, the most important of which is *collagen*. The organic material of the bones, the tendons, the cartilage and the skin, is to a great extent comprised of collagen. When this collagen is obtained from different tissues it is found to vary slightly in its composition and this has led some writers to regard it not as a definite chemical compound, but rather as a mixture the composition of which is variable within certain limits.

When collagen is heated in water to 80 or 90°C. it is converted slowly into the protein *gelatin*. This conversion would be greatly accelerated if the temperature of the water were raised to or above the boiling point (under pressure) or by the use of dilute acids, but such a procedure would, in turn, result in a further hydrolysis of the gelatin, as soon as it was produced, and so greatly lessen the yield and quality of the product. This reaction was considered by Hofmeister<sup>1</sup> to be an hydrolysis, the elements of one molecule of water being added to the collagen in its conversion to gelatin. He writes the equation,

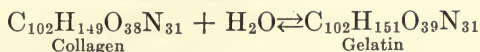

and considers collagen as the anhydride of gelatin. He furthermore regards the reaction as reversible for upon heating gelatin to 130°C. he reports a regeneration of collagen. That this is a true conversion of gelatin to collagen has been questioned by Alexander<sup>2</sup> who considers it more probable that, "upon

<sup>1</sup> F. HOFMEISTER, *Z. physiol. Chem.*, **2** (1878), 299.

<sup>2</sup> J. ALEXANDER, "Allén's Commercial Organic Analysis," vol. 8 (1913), 586.

driving off the water, the constituent particles of gelatin approach so close as to form an irreversible gel, thus rendering it insoluble."

Emmett and Gies<sup>1</sup> also contend that Hofmeister was incorrect in believing that gelatin reverted to collagen upon heating to 130 degrees. They find that the dried product is indeed less soluble than the original gelatin, but that it is readily digested by trypsin while collagen is not. They also find that ammonia is evolved during the hydrolysis of collagen to gelatin in hot water, a fact which goes further to prove the irreversibility of the reaction. On boiling gelatin no ammonia was evolved. They conclude that gelatin arises from an intramolecular rearrangement of collagen on treating the latter with boiling water, and that the resultant gelatin is not a simple hydrate of collagen, as shown by the liberation of ammonia upon boiling the latter with water.

Just as the collagens obtained from different sources vary somewhat in their chemical composition, so also will the gelatins obtained from different collagens vary. This is shown in the following table:

TABLE 15.—ELEMENTARY COMPOSITION OF COLLAGEN AND GELATIN

Material examined	Carbon	Hydrogen	Nitrogen	Sulphur	Oxygen	Authority
Collagen.....	50.75	6.47	17.86	....	24.92	Hofmeister <sup>1</sup>
Gelatin from bone.....	50.00	6.50	17.50	....	26.00	Fremy <sup>2</sup>
Gelatin from ligaments	50.49	6.71	17.90	0.57	24.33	Richards & Gies <sup>3</sup>
Gelatin from tendons..	50.11	6.56	17.81	0.26	25.26	Van Name <sup>4</sup>
Gelatin from isinglass	48.69	6.76	17.68	....	....	Faust <sup>5</sup>
Gelatin (commercial)..	49.38	6.80	17.97	0.70	25.13	Chittenden <sup>6</sup>
Gelatin, ash free.....	50.52	6.81	17.53	....	25.15	C. R. Smith <sup>7</sup>

<sup>1</sup> HOFMEISTER, *loc. cit.*

<sup>2</sup> FREMY, *Chem. Zentr.*, **42** (1871), 516.

<sup>3</sup> RICHARDS and GIES, *Am. J. Physiol.*, **8** (1903).

<sup>4</sup> VAN NAME, *J. Exptl. Med.*, **2** (1897).

<sup>5</sup> FAUST, *Arch. exptl. Path. Pharm.*, **41** (1898).

<sup>6</sup> CHITTENDEN, *J. Physiol.*, **12** (1891), 33.

<sup>7</sup> C. R. SMITH, *J. Am. Chem. Soc.*, **43** (1921), 1352.

Although the sulphur content is very low, it seems from very careful work by Sakidoff<sup>2</sup> and by Mörner<sup>3</sup> that it is nevertheless a necessary constituent of the gelatin molecule. On preparing gelatin from tendons which had been previously digested with

<sup>1</sup> A. EMMETT and N. GIES, *J. Biol. Chem.*, **3** (1907), xxxiii.

<sup>2</sup> SAKIDOFF, *Z. physiol. Chem.*, **39** (1903), 396; **41** (1904), 15.

<sup>3</sup> MÖRNER, *ibid.*, **28** (1899), 471.

either trypsin, or 0.25 per cent potassium hydroxide, or with sodium hydroxide followed by sodium carbonate, Sakidoff found the resulting gelatin to have in each case a sulfur content of 0.30 to 0.526 per cent. Mörner obtained one gelatin with as little as 0.2 per cent of sulphur.

Of the greatest importance in our every-day life is the effect which tannic acid and certain other substances have upon collagen in converting it into leather. The use of extractions from the bark of trees, such as the oak or hemlock, or the wood of the chestnut, the quebracho, etc., has been applied from the earliest ages in the preservation and tanning of hides and pelts. Of more recent origin is the introduction of chrome tanning, in which process the hides are treated first with a solution of sulphuric acid and sodium chloride, and later with a solution of basic chromic sulphate. Neither of these processes is by any means completely understood even today, but it is known that these liquors produce an insolubilization in the collagen of the hides, for when fully tanned boiling water will have practically no effect upon them.

Collagen may be prepared by extracting bones first with dilute hydrochloric acid to remove the inorganic salts, and second with dilute alkali to remove extraneous organic matter. Or it may be obtained from tendons or the corium layer of skin by extracting with lime water or dilute alkali, and thoroughly washing with water. It is a colorless substance which swells in cold water, in dilute acids, and in dilute alkalies, but is insoluble in all of the above, and in organic solvents. When the temperature is raised, in water, dilute acid or alkali, it is changed into gelatin. It is soluble in strong alkalies, but not in carbonates. It is readily dissolved by pepsin hydrochloride, but trypsin has no effect upon collagen, unless the latter has first been heated with water to 70°C., or swollen with acids and again contracted by heating. It seems probable that the collagen molecule is completely resistant to the action of trypsin, but that as soon as a little hydration has taken place, *i.e.*, as soon as a small amount of gelatin has been produced from the collagen molecule, then the trypsin will become active; its attack is probably confined to the gelatin molecule.

The different behavior of pepsin and trypsin on the hydrolysis of proteins is accounted for by Plimmer<sup>1</sup> by assuming that the

<sup>1</sup> R. PLIMMER, "Chemical Constitution of the Proteids," 2nd ed. (1912), part II, p. 11.

latter is unable to open up a closed ring compound. He says, "Trypsin will hydrolyze a chain of amino acids with a terminal amino or carboxyl group. Pepsin will open the anhydride ring at one or more junctions and give several proteoses and peptones with free terminal  $\text{—NH}_2$  and  $\text{—COOH}$  groups capable of being attacked by trypsin. Those proteins which are resistant to the action of trypsin until they have been acted upon by pepsin will have all their units contained in the anhydride ring." This statement is generally accepted although Procter<sup>1</sup> urges that it seems to require confirmation. Since gelatin is readily hydrolyzed by trypsin, while collagen is not attacked, it seems probable that the latter possesses a closed ring structure, and as the conversion to gelatin seems to involve the addition of the elements of water, an anhydride formation may be assigned to collagen:

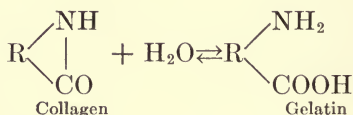

The swimming bladders of fish are composed of nearly pure collagen, and this variety is more readily soluble than any other. The scales and skin of fish also contain a large amount of collagen which is likewise very easily dissolved.

The cleavage products of collagen are identical with those obtained from gelatin, and will be discussed in the next section.

**2. Gelatin.** *General Description and Properties.*—Gelatin is a nearly colorless, transparent, amorphous substance, flexible and horny when in the normal dry condition, in which state, however, it retains about 16–18 per cent of water. The natural color is of a slightly yellowish cast. Precipitated from alcohol or salts, however, it is pure white, and nearly water-free. Gelatin swells to many times its normal volume when immersed in cold water or in dilute acids or alkalis. The degree of acidity, or of alkalinity, or of salt content of the water greatly modifies the extent to which the gelatin will swell. A slightly acid solution seems most favorable for maximum swelling.<sup>2</sup> On raising the temperature to about 35°C. the swollen jelly goes readily

<sup>1</sup> H. R. PROCTER, "First Report on Colloid Chemistry," British Assoc. for the Adv. of Science (1917), 7.

<sup>2</sup> Cf. Chap. IV.



into solution. The absorption of water has been shown by Quincke<sup>1</sup> to result in a volume contraction, the volume of the swollen jelly being less than the sum of the volumes of the original dry gelatin and the absorbed water. Wiedemann and Lüdeking<sup>2</sup> later showed that the process was also accompanied by a liberation of heat, as would be expected from Quincke's findings. Applying the principle of LeChattelier this means that low temperatures will favor the absorption of water by gelatin, while if the opposite effect is required, *e.g.*, if it is desired to hasten the drying out process, a relatively high temperature will be found most favorable.

Gelatin is a typical colloid of the emulsoid type, and many of its most important and striking properties are dependent upon this condition. As an emulsoid colloid, the viscosity of its solutions is high and very variable with slight alterations in the temperature, the concentration, the hydrogen-ion concentration, etc. As an emulsoid colloid gelatin exerts a marked protective action upon salts which are precipitated in its presence, such precipitations usually coming down in a very finely divided suspensoid condition. In analytical determinations such effects are often very troublesome and, unless well understood, may lead to incorrect postulations. As an emulsoid colloid gelatin finds favor among manufacturers of ice-cream, as it will prevent the crystallization of water upon the long-standing of the cream.

When a solution containing one or more per cent of gelatin is allowed to stand at about 10°C. a firm jelly will be formed. This is probably the most characteristic and important property of gelatin, and a large part of the investigational work that has been done upon gelatin has been centered about this property. As an adhesive, gelatin, in the form of glue, finds one of its most important uses. All of these important properties will be taken up at length in subsequent chapters.

When heated in the air gelatin swells to many times its original volume, becomes soft, and finally disintegrates, evolving ammonia and a large amount of pyridine bases, and leaving a residue of hard, difficultly combustible charcoal.

Gelatin has the peculiar property of lowering the solubility of easily soluble salts and of increasing the solubility of difficultly

<sup>1</sup> QUINCKE, *Arch. ges. Physiol.*, **3** (1870), 332.

<sup>2</sup> WIEDEMANN and LÜDEKING, *Ann. Physik. Chem.*, **25** (1885), 145.

soluble salts. The following figures of Pauli and Samec<sup>1</sup> illustrate this property:

TABLE 16.—CHANGES IN SOLUBILITY THROUGH GELATIN ADDITIONS

Solute	100 g. water	+4 Per cent gelatin	+10 Per cent gelatin
Ammonium chloride.....	28.49	27.55	26.48
Magnesium chloride.....	35.94	35.22	35.13
Ammonium sulphocyanate.....	62.46	61.46	58.92
	100 g. water	1.5 Per cent gelatin	
Calcium sulphate.....	0.223	0.295	.....
Tricalcium phosphate....	0.011	0.018	.....
Calcium carbonate.....	0.004	0.015	.....
Silicic acid.....	0.023	0.027	.....

According to Bechhold and Ziegler<sup>2</sup> the melting point of gelatin is altered by the presence of either inorganic salts or organic substances. They give the following figures:

Composition of solution	Melting point
10 per cent gelatin .....	31.66
10 per cent gelatin + 1 mol. NaCl .....	28.5
10 per cent gelatin + 2 mols. Na <sub>2</sub> SO <sub>4</sub> .....	34.2
10 per cent gelatin + 1 mol. NaI.....	10.0
10 per cent gelatin + 1 mol. grape sugar.....	32.25
10 per cent gelatin + 2 mols. glycerin.....	32.17
10 per cent gelatin + 2 mols. alcohol.....	30.0
10 per cent gelatin + 1 mol. urea.....	26.3

When solutions of gelatin are examined with the ultramicroscope, some investigators have failed and others have succeeded in obtaining visible amicros. Zsigmondy<sup>3</sup> reported that a hot solution of pure gelatin showed a clear field except for a slight Tyndall effect which he ascribed to traces of impurities. After

<sup>1</sup> WO. PAULI and M. SAMEC, *Biochem. Z.*, **17** (1909), 235.

<sup>2</sup> H. BECHHOLD and J. ZIEGLER, *Z. physiol. Chem.*, **52** (1905), 185.

<sup>3</sup> ZSIGMONDY, "Colloids and the Ultramicroscope."



standing for 2 days, however, a 0.2 per cent solution of gelatin appeared filled with particles of about  $5\mu\mu$  diameter. Elliott,<sup>1</sup> however, experienced no difficulty in observing freely moving amicros in fresh dilute solutions of gelatin.

*Solubility.*—Most of the organic solvents fail to dissolve gelatin, it being completely insoluble in ether, chloroform, carbon disulphide, benzene, fixed oils, volatile oils, and absolute alcohol. It is also insoluble in water at the freezing point containing as little as 10 per cent of alcohol. A procedure for the determination of gelatin is based upon this fact. Alcohol in 85 to 95 per cent concentration is used as a precipitant for gelatin, the latter being thrown down as a white precipitate, stringy if the alcohol is at 20°C. or above, but finely divided and almost granular if the temperature is kept at about 10°. Tannic acid and phosphotungstic acid precipitate gelatin quantitatively if kept below 17°C. These reagents serve, therefore, in both the qualitative and quantitative estimation of gelatin. It was pointed out by Ricevuto,<sup>2</sup> however, that tannin did not precipitate gelatin unless the latter were in a negative condition or unless salts were present. He found that carefully dialyzed gelatin was not precipitated by tannin. If this may be interpreted in terms of Loeb's<sup>3</sup> findings it would mean that only when the gelatin is in the form of a gelatinate may it react with tannin. The tannin molecule is, therefore, positive with respect to the gelatin. If the reaction is chemical in its nature tannin gelatinate must be the substance precipitated. There is, however, some objection to considering this as a chemical reaction, because the product formed is variable in composition. It is, however, not only possible, but could hardly be averted, that some of either the gelatin or the tannin, depending on which was present in excess, should be carried down with the precipitate, contaminating it, as is well known to happen in thoroughly understood inorganic precipitations. This would account for any variations noted in the composition of the tannin gelatinate. On the other hand it is as well recognized that oppositely charged colloids mutually precipitate each other, and von Schroeder<sup>4</sup> has shown that the

<sup>1</sup> F. ELLIOTT, Communication to 60th General Meeting, *Am. Chem. Soc.*, Chicago (1920).

<sup>2</sup> RICEVUTO, *Kolloid-Z.*, **3** (1908), 114.

<sup>3</sup> Cf. Chap. V.

<sup>4</sup> J. VON SCHROEDER, *Kolloidchem. Beihfte*, **1** (1909), 1.

adsorption isotherm is closely followed in the system tannin-gelatin, during precipitation. An objection to the colloid explanation, however, is found in the fact that gelatin is not readily precipitated by electrolytes, nor by other colloids of opposite electric charge.

Certain salts, notably the sulphates of ammonium, zinc, and magnesium precipitate gelatin quantitatively if added to the point of saturation, and if the temperature is kept low. These salts have found extensive use in the separation of gelatin (and other proteins) from their products of hydrolysis, for by arbitrarily varying the percentage of saturation of the salt solution, the protein and its cleavage products may be fractionally separated. It is customary to consider the unchanged protein as insoluble in a half-saturated solution of these sulphates, the proteoses as insoluble in a saturated solution, and the peptones and amino-acids as soluble at all concentrations of the salts.

*Reactions.*—Potassium dichromate reacts with gelatin in the presence of light to produce a jelly, which, on drying out, is insoluble. This property is made use of in photolithography. Many methods of applying the principle have been developed, but in general the process consists in exposing a plate of dichromated gelatin to light through a photographic negative. The light acts on the gelatin producing the insoluble phase under the thinner parts of the negative. On soaking in water the protected portions swell more than the exposed parts and a reproduction of the picture is secured.

A large number of reactions have been reported for gelatin with divers reagents, but many of these are of transient interest only. When chlorine gas is passed through a dilute solution (about 1 per cent) of gelatin,<sup>1</sup> the liquid first remains clear, then it froths strongly, and when the chlorine is present in excess the frothing subsides and the gelatin is precipitated as a white granular mass. On washing and drying *in vacuo* over sulphuric acid a yellowish-white powder is obtained which is insoluble in water or alcohol, but soluble in alkalis. This reaction has been made the basis for the estimation of gelatin in tub-sized papers by Cross, Bevan and Briggs.<sup>2</sup> They found, by allowing the chlorine gas to act upon the gelatin, spread out into very thin layers on cotton yarn by immersing the latter in a gelatin solution, that 15.4 per cent

<sup>1</sup> S. RIDEAL and C. G. STEWART, *Analyst*, **22** (1897); 228.

CROSS, BEVAN, and BRIGGS, *J. Soc. Chem. Ind.*, **27** (1908), 260.

of chlorine gas was retained, forming a gelatin chloramine. On washing with sulphurous acid the chlorine was liberated.

Bromine<sup>1</sup> and iodine<sup>2</sup> have been shown, when applied in the proper manner, to give results which are analogous to those obtained with chlorine. There seems to be much difficulty however, in so adjusting the technique of the process that the results may be certain and readily duplicated.

Potassium ferrocyanide or ferricyanide do not ordinarily produce precipitates with gelatin, but Mörner<sup>3</sup> has shown that if potassium ferrocyanide and acetic acid are added to gelatin, and the temperature kept below 30°C., and only dilute solutions are used, a precipitate may be obtained, but is dissolved by the least excess of either the ferrocyanide or the gelatin. The presence of salts, organic acids, or bases prevent the formation of the precipitate.

Formaldehyde produces a condensation product with gelatin rendering the latter insoluble. Lumière and Seyewetz<sup>4</sup> report that from 4.0 to 4.8 per cent of formaldehyde combines chemically with the gelatin when a 10 per cent solution of the former is allowed to act upon dry gelatin. This product is known as formo-gelatin, and was shown to be decomposed by cold 15 per cent hydrochloric acid, by repeated treatment with boiling water, and by heating to 110°C. The author<sup>5</sup> has found in a study of this substance that when a 10 per cent solution of formaldehyde is added to a solution of gelatin of from about 5.5 to 22 per cent concentration:

1. The viscosity varies directly as the amount of formaldehyde added. The greater the purity of the gelatin, and the higher the concentration, the less the amount of formaldehyde required to produce insolubility.

2. The jelly-strength varies inversely as the amount of formaldehyde added. This effect is the more marked in the weaker grades of gelatin, and in the lower concentrations.

3. The viscosity increases with the time.

4. The viscosity decreases with rise in temperature up to about 40°C. Above this temperature the viscosity rapidly

<sup>1</sup> ALLEN and SEARLE, *Analyst*, **12** (1887), 258.

<sup>2</sup> HOPKINS and BROOKE, *J. Physiol.*, **22** (1897), 184.

<sup>3</sup> MÖRNER, *Z. physiol. Chem.*, **28** (1899), 471.

<sup>4</sup> LUMIÈRE and SEYEWETZ, *Bull. soc. chim.*, **35** (1906), 872.

<sup>5</sup> R. H. BOGUE, *Chem. Met. Eng.*, **23** (1920), 7-9.



increases to the setting point. Attempts have been made to utilize the properties of formo-gelatin in the preparation of an insoluble glue, but the effort has not been successful for several reasons. These will be discussed in a subsequent chapter.

Picric acid precipitates gelatin, when added in excess, throwing down a stringy, sticky, yellow precipitate. On raising the temperature this becomes soluble, but again appears on recooling the solution.

Platinic sulphate precipitates gelatin in the form of small brown flakes which quickly turn black. Davy regards this as a very delicate test for gelatin, more sensitive even than the tannin test, and unaffected by the presence of albumin, but Alexander has been unable to confirm this point. The chloride of platinum throws down gelatin as a yellow precipitate.

Gelatin is unlike many others of the proteins of this group in that it is not precipitated by mineral acids nor by acetic acid. Neither is it thrown out of solution by alum, lead acetate, ferric chloride, or silver nitrate. Gelatin may be precipitated, however, by the chlorides of gold and tin (stannous), which, together with the chloride of platinum above described, are dissolved by bringing the solution to the boiling point, but reappear upon cooling. If neutral salts or a little hydrochloric acid are present, gelatin may be thrown out of solution by mercuric chloride or nitrate and by basic lead acetate. Chromic acid and mercury-potassium iodide also precipitate gelatin, but the precipitate becomes soluble on heating.

*Constitution.*—Since gelatin is obtained from collagens which vary widely in their source, and since it is exceedingly difficult to be certain that one is dealing with absolutely pure gelatin, the composition of the material as reported by different investigators shows conspicuous variations. The elementary composition of several gelatins was shown on page 50. Sulphur has usually been reported in small amounts, but it is still an open question whether this small amount of sulphur is a necessary and constant constituent of the gelatin molecule, or is an impurity. The carbon content is low, which accounts for the low calorific value of gelatin. According to Berthelot and Stohmann<sup>1</sup> this value is some 500 to 700 calories below the average of the albuminous substances. The nitrogen content is relatively high.

The first record which we have of the amino-acid constitution

<sup>1</sup> BERTHELOT and STOHMANN, *J. prakt. Chem.*, **44** (1891), 336.

of gelatin was reported by Braconnot<sup>1</sup> in 1820. He discovered that glycocoll (glycine) is an abundant constituent of gelatin. The analyses of H. D. Dakin, given on page 36, show that glycine is present to the extent of 25.5 per cent in gelatin. Arginine, proline, oxyproline, lysine, and leucine are also present in conspicuous amounts. Tryptophane and tyrosine are apparently absent.

The distribution of nitrogen among the several groups according to the method of Van Slyke is shown in the table on page 43. In this arrangement the value of the figures obtained for *non-amino nitrogen of the filtrate* stand out as noticeably large. This group, it will be recalled, comprises the proline and oxyproline. The *amino nitrogen of the filtrate* is also large, due principally to the glycine. Cystine is noticeable by its absence. Lysine is rather higher in gelatin than in most proteins, and histidine and ammonia are low.

Trypsin acts very slowly upon gelatin, and produces only albumoses and peptones. Even after 10 months' action Levene<sup>2</sup> obtained only small amounts of amino-acids by the tryptic digestion of gelatin. He observed, however, that the glycine content of the albumoses was greater, and of the peptones less, than the glycine content of the original gelatin. He accounted for this by showing that in the conversion of the albumose to peptone only glycine, and traces of leucine, were split off from the molecule. The action of pepsin is very similar to that of trypsin, being slow and producing, for the most part, only the relatively large intermediate molecules. The action of the proteolytic ferments of the liver on gelatin is somewhat more rapid and complete than that of trypsin and pepsin.<sup>3</sup> Peptone, diamino acids, and mono-amino acids are produced.

The action of oxydising agents, as permanganates, upon gelatin results in the production of oxalan,  $\text{NH}_2\text{CO.NH.C}_2\text{O}_2\text{NH}_2$ ; ammonium oxamate,  $\text{C}_2\text{O}_3\text{NH}_2\text{NH}_4$ ; ammonium oxalate; and the acids: oxalic, succinic, benzoic, formic, acetic, and butyric. Benzaldehyde, propionic, and valerianic acids have also been observed.<sup>4</sup>

<sup>1</sup> BRACONNOT, *Ann. chim. phys.*, **13** (1820), 113.

<sup>2</sup> LEVENE, *Z. physiol. Chem.*, **41** (1904), 8; 99.

<sup>3</sup> ARNHEIM, *Z. physiol. Chem.*, **40** (1903), 234.

<sup>4</sup> SEEMANN, *Zentr. Physiol.*, **18** (1904), 285.



Gelatin gives a distinct violet biuret reaction.<sup>1</sup> The Millon's reagent gives a faint pink coloration, and the xanthoproteic reaction results in a faint yellow coloration. Since Millon's reaction is specific for tyrosine and the xanthoproteic reaction is usually accredited to tryptophane, and since both of these amino-acids have been reported absent in gelatin, it follows that either the positive tests obtained are the result of impurities in the gelatin, or else that those amino-acids upon which the reactions depend are present, even though they have not yet been isolated, in the gelatin molecule. The lead sulphide reaction, the Molisch reaction, and the Adamkiewicz reaction are usually reported negative in pure gelatin, but the former is observed in the commercial product, and the Molisch reaction has been reported positive by Hofmeister<sup>2</sup> and by Klug.<sup>3</sup>

Gelatin has been reported to produce symptoms of poisoning when injected subcutaneously or intravenously.

*The Decomposition of Gelatin by Bacteria.*—A very large number of bacteria have been described which produce liquefaction of gelatin with more or less rapidity. In most cases the action is relatively slow, and it is in fact difficult to draw a sharp line between those varieties which do and those which do not produce liquefaction, for some types have been found to produce this effect only after several months. The Society of American Bacteriologists has recommended that the tests be continued for 6 weeks before the term non-liquefying be applied in any specific case. A few types have had the term *liquefaciens* appended to their name in signification of their exceptional ability in this direction, as, for example, the *B. liquefaciens*, *B. liquefaciens boris*, *B. liquefaciens parvis*, and *B. fluorescens liquefaciens*.

The products of decomposition by bacteria appear to be, firstly, peptones and, secondly, amino-acids. This fact has led to the term peptonization, as descriptive of the process. The following table by Rideal and Stewart<sup>4</sup> shows the products of the decomposition of gelatin by *B. fluorescens liquefaciens*, and *B. prodigiosus*, after varying intervals of incubation at 20 to 21°C.

It will be observed that the gelatin and albumoses are first hydrolyzed to peptones, thereby producing liquefaction, and

<sup>1</sup> See page 45.

<sup>2</sup> HOFMEISTER, *Z. physiol. Chem.*, **2** (1878), 299.

<sup>3</sup> KLUG, *Pflüger's Arch. Physiol.*, **48** (1891), 100.

<sup>4</sup> RIDEAL and STEWART, *Analyst*, **22** (1897), 255.

TABLE 17.—THE DECOMPOSITION OF GELATIN BY BACTERIA<sup>1</sup>

	Gelatin and albumoses	Gelatin	Albumoses	Ammonia and volatile bases	Bases and extractives	Peptone and nitrogen unaccounted for	Albumin and cellulose
Original gelatin . . . . .	89.3	47.9	41.4	0.24	4.91	5.55	...
<i>B. flor. liquefaciens</i> , 20–21°C. 1 day ..	85.9	55.5	30.4	2.12	.....	.....	...
2 days .	54.3	30.7	23.6	3.58	8.37	33.8	...
3½ days .	19.15	8.45	10.7	4.98	38.4	33.6	...
16 days .	17.12	10.7	6.42	13.33	58.9	9.85	0.8
<i>B. prodigiosus</i> , 20–21°C. 14 days	83.1	49.9	33.2	3.97	.....	.....	...

<sup>1</sup> The figures are expressed as percentage of total nitrogen. These were calculated by the author from the figures of RIDEAL and STEWART.

rendering the consistency of the solution limpid and non-viscous, but by continued action the bacteria attack the peptones produced and convert them to amino-acids. Indole, skatole, and similar putrefactive products are either not produced at all from pure gelatin, or are formed only in very small amounts. The presence of such substances in conspicuous amounts in decomposed glue is evidently due to impurities which are inevitably present. Ammonia is slowly and regularly produced as decomposition continues, but is not present in large amounts until the action has proceeded for a long time.

*Preparation and Purification.*—Whenever the housewife boils a bone for a soup she is manufacturing gelatin, and this gelatin is very much the same substance, except for fat and portions of flesh which were not previously removed, as is obtainable at every grocery store. The ossein of the bone, which is mainly collagen, is converted by the boiling process into gelatin. If it is desired to obtain the pure protein, a pure collagen must first be prepared and this heated to 70 to 80°C. for several hours. Heating with fresh portions of water may be repeated several times, and the combined solutions concentrated at a low temperature under diminished pressure. This process eliminates the possibility of the gelatin molecules undergoing further hydrolysis into proteoses, peptones, or amino-acids. The gelatin may then be allowed to gel, cut into sheets, and dried in the air. If it is desired to free it as completely as possible of all extraneous salts the thin sheets of gelatin may be suspended in cold distilled water. This should be changed frequently or

arranged so that the supply and discharge are continuous. Further purification may be obtained by precipitating in alcohol. For this purpose a dilute solution of the gelatin should be poured into cold 95 per cent alcohol, redissolved in warm water, and this process repeated several times. Gelatin prepared in the above manner may be considered as chemically pure. Some investigators have carried the purification process a step farther, however, by deaminizing the product. This was done by Blasel and Matula<sup>1</sup> as follows: 200 g. of the best obtainable commercial gelatin were dissolved in 1 liter of distilled water. A liter of a 20 per cent solution of sodium nitrite was added. The mixture was cooled and 140 g. of glacial acetic acid was carefully added. After standing for 12 hours the mixture was heated on a water bath for 2 hours. Solid ammonium sulphate was then added to precipitate the gelatin, and it was subsequently purified by dialysis against running distilled water for 2 weeks. None of the properties of the deaminized gelatin differ greatly, however, from the product as usually obtained and this process is not essential to the obtaining of the pure protein *gelatin*. The product of any of the above methods may, according to Loeb,<sup>2</sup> be either a metal gelatinate, a neutral gelatin, or a gelatin salt. It is most probably a calcium or sodium gelatinate. To obtain the simple gelatin it is necessary to bring this salt to the isoelectric point, which for gelatin is  $\text{pH} = 4.7$ . This may be done by allowing hydrochloric acid of the proper concentration—N/128 to N/512—to react with the granulated gelatin for  $\frac{1}{2}$  hour at  $10^{\circ}\text{C}$ ., and afterward thoroughly washing out the excess acid with cold distilled water. The hydrochloric acid reacts with the calcium gelatinate forming calcium chloride, which is washed out, and pure gelatin remains.<sup>3</sup>

*The Distinction between Gelatin and Glue.*—The chemical distinction between gelatin and glue is merely a distinction of purity. Gelatin is a protein of a supposedly definite molecular constitution, derived by a (chiefly) hydrolytic decomposition of collagen, and possessing certain well-defined physical and chemical characteristics which have already been set forth. Among these the precipitability in a half saturated solution of magnesium

<sup>1</sup> BLASEL and MATULA, *Biochem. Z.*, **58** (1914), 417.

<sup>2</sup> J. LOEB, *J. Gen. Physiol.*, **1** (1918), 45.

<sup>3</sup> J. LOEB, *loc. cit.*; Cf. also ADA M. FIELD, *J. Am. Chem. Soc.*, **43** (1921), 667.



sulphate may be emphasized as a point of differentiation of the pure protein from its products of hydrolytic decomposition. If the material in hand contains such cleavage products in quantity, or if the protein gelatin is intermixed with other proteins as mucin, keratin, elastin, etc., then it cannot of course be regarded as pure gelatin. The cleavage products, especially the proteose obtained upon heating gelatin in water, have been spoken of as  $\beta$  gelatin, but the mixture must not be considered as true gelatin.

In commercial parlance a gelatin differs from a glue only in that the former is a very high grade product, is of high jelly strength, is light in color, gives solutions that are reasonably clear, is sweet, and does not contain excessive impurities. An edible gelatin differs from a technical gelatin in containing only such traces of harmful ingredients as are permitted by the Pure Food Laws, and which is produced from such stock, and by such sanitary methods, that objection may not be had to it from an ethical point of view.

The highest grades of glue are usually designated as technical gelatins. In glue manufacture, however, provision is not usually maintained to carefully separate the pure collagen from other impure stock, with the result that many impurities, both organic and inorganic, may be introduced. And in order to extract the maximum amount of glue the cooking is prolonged at high temperatures with the result that a considerable part of the protein is hydrolyzed to smaller molecules.

The best grades of gelatin are converted into chemical gelatin by dialyzing out the mineral impurities, using a dilute acid solution and by precipitation with alcohol.

**3. Keratin.**—The *keratins* are found in the hard structure of the nails, hair, horns, hoofs, feathers, wool, tortoise shell, whale-bone, etc. Keratin is also found in brain and nerve tissue, and known as *neurokeratin*. The membrane of some varieties of eggs is likewise a keratin.

The most characteristic property of the keratins is the unusually high content of cystine, and consequently of sulphur, which they reveal. The elementary composition of keratins obtained from various sources is shown in the following table.

It is observed that while the sulphur is relatively high in most cases, yet it varies quite considerably. It seems to be present, for the most part, in a somewhat loose combination, and may be largely removed by the action of alkalies or water at high tem-

TABLE 18.—ELEMENTARY COMPOSITION OF KERATINS

Source of keratin	Carbon	Hydrogen	Nitrogen	Sulphur	Oxygen	Authority
Human hair.....	50.65	6.36	17.14	5.00	20.95	v. Laar
Wool.....	50.65	7.03	17.71	4.61	20.00	Schorer
Rabbit fur.....	49.45	6.52	16.81	4.02	23.20	Kühne and Chittenden
Nails.....	51.00	6.94	17.51	2.80	21.75	Mülder
Horn (cows).....	51.03	6.80	16.24	3.42	22.51	Tilanus
Hoof (horses)....	51.41	6.96	17.46	4.23	19.94	Mülder
Feathers.....	52.46	6.94	17.74	?	22.86	.....
Tortoise shell....	54.89	6.56	16.77	2.22	19.56	Mülder
Whalebone.....	51.86	6.87	15.70	3.60	21.97	v. Kerkhoff
Egg membrane...	53.92	7.33	15.08	1.44	.....	Pregl
Neurokeratin.....	56.99	7.53	13.15	1.87	20.46	Kühne and Chittenden

peratures, especially under pressure. With alkalis it forms sulphides, and with water it decomposes into hydrogen sulphide and mercaptans, leaving what Bauer<sup>1</sup> calls *atmidkeratin* and *atmidkeratose*. Despite the looseness of the combination, Mörner concludes that the sulphur is practically all present in the form of cystine. The following table shows the cystine content of a number of keratins:

TABLE 19.—CYSTINE CONTENT OF KERATINS

Source of keratin	Cystine	Authority	Source of keratin	Cystine	Authority
Human hair.....	13.9	Mörner	Ox hoof.....	5.4	Buchtala
Human hair.....	14.0	Buchtala	Horse hair.....	8.0	Buchtala
Human hair.....	13.0	Buchtala	Horse hoof.....	3.2	Buchtala
Human hair.....	14.5	Buchtala	Pig bristles.....	7.2	Buchtala
Human hair (white) .	11.6	Buchtala	Pig hoof.....	2.2	Buchtala
Human nails.....	5.2	Buchtala	Sheep wool.....	7.3	Abderhalden
Ox hair.....	7.3	Buchtala	Sheep horn.....	7.3	Abderhalden
Ox horn.....	6.8	Mörner	Egg membrane (hen)	7.62	Körner

The keratins from different sources also vary greatly in their content of other amino-acids besides cystine. Thus glutamic acid is present to the extent of 17.2 per cent in the keratin from

<sup>1</sup> BAUER, *Z. physiol. Chem.*, **35** (1902), 343.



sheep horn,<sup>1</sup> but to only 2.3 per cent in that from goose feathers.<sup>2</sup> Tyrosine was found absent in the keratin from the shell membrane of the hen's egg,<sup>3</sup> but present to the extent of 10.6 per cent in the egg membrane of *scyllium stellare*.<sup>4</sup> Other variations will be noticed from the following table:

TABLE 20.—DISTRIBUTION OF NITROGEN IN KERATINS

	Keratin <sup>1</sup> from horse hair	Keratin <sup>2</sup> from sheep wool	Keratin <sup>3</sup> from goose feathers	Keratin <sup>4</sup> from sheep horn	Shell mem- brane <sup>5</sup> of hen's egg	Egg mem- brane <sup>2</sup> of <i>scyllium stellare</i>
Glycine.....	4.7	0.58	2.6	0.45	3.9	2.6
Alanine.....	1.5	4.40	1.8	1.6	3.5	3.2
Valine.....	0.9	2.80	0.5	4.5	1.1	....
Leucine.....	7.1	11.5	8.0	15.3	7.4	5.8
Serine.....	0.6	0.1	0.4	1.1	....	....
Aspartic acid...	0.3	2.3	1.1	2.5	1.1	2.3
Glutamic acid...	3.7	12.9	2.3	17.2	8.1	7.2
Cystine.....	7.98	7.3	....	7.5	7.62	?
Phenylalanine...	0.0	....	0.0	1.9	....	3.3
Tyrosine.....	3.2	2.9	3.6	3.6	0.0	10.6
Proline.....	3.4	4.4	3.5	3.7	4.0	4.4
Histidine.....	0.61	....	....	....	....	1.7
Arginine.....	4.45	....	....	2.7	....	3.2
Lysine.....	1.12	....	....	0.2	....	3.7

<sup>1</sup> ABDERHALDEN and WELLS, *Z. physiol. Chem.*, **46** (1905), 31.

<sup>2</sup> PREGL, *loc. cit.*

<sup>3</sup> ABDERHALDEN and LE CONNT, *loc. cit.*

<sup>4</sup> ABDERHALDEN and VOITINOVICI, *loc. cit.*

<sup>5</sup> ABDERHALDEN and EBSTEIN, *loc. cit.*

The horny material of birds' gizzards, known as *koilin*, which is very low in its cystine content, and egg membranes are not considered to belong to the keratin group by Hofmann and Pregl<sup>5</sup> because of their low sulphur content.

The keratins are resistant to the ordinary solvents, being insoluble in alcohol and ether, and unaffected by boiling at

<sup>1</sup> ABDERHALDEN and VOITINOVICI, *Z. physiol. Chem.*, **52** (1907), 348.

<sup>2</sup> ABDERHALDEN and LECONNT, *ibid.*, **48** (1905), 40.

<sup>3</sup> ABDERHALDEN and EBSTEIN, *ibid.*, **48** (1906), 530.

<sup>4</sup> PREGL, *ibid.*, **56** (1908), 1.

<sup>5</sup> HOFMANN and PREGL, *Z. physiol. Chem.*, **52** (1907), 448.

ordinary pressures. Under pressure at 150°C. and higher they decompose, evolving hydrogen sulphide or mercaptans, and produce a solution which, unlike gelatin, does not produce a jelly on cooling, and if it is evaporated to dryness the residue will again become insoluble.

The keratins are hygroscopic, but do not swell appreciably in moist air or water. In alkalies no effect is noted until the concentration becomes rather high,<sup>1</sup> but in 20 per cent solutions of alkali the keratins swell and dissolve on boiling. If such a solution is neutralized with an acid a white flocculent precipitate is formed, and hydrogen sulphide is evolved.<sup>2</sup>

Acids in general dissolve the keratins more or less completely, swelling taking place in the cold acid, and solution being effected on boiling. Sulphuric acid seems to be best suited for the decomposition of the keratins, for although hydrochloric acid attacks most of these substances, hair remains unaffected even by fuming hydrochloric acid.

Smith<sup>3</sup> states that keratin is unaffected by either pepsin or trypsin, but Dreaper<sup>4</sup> questions the correctness of the statement so far as it pertains to trypsin.

Keratin reacts with Millon's reagent, and gives the xanthoproteic reaction.

Keratin may be prepared<sup>5</sup> by subjecting a horny structure, quills, etc., to digestion with a mixture of ether and alcohol, and subsequently with an acid solution of pepsin at 40°C. The residue is dissolved by prolonged boiling in acetic acid, and the solution strained, concentrated, and dried to a powder which will be brownish-yellow, and insoluble in water, alcohol, ether, dilute acids, and pepsin hydrochloride.

A very interesting proposition has resulted from the relation of keratin to hair and wool. Professor Zuntz<sup>6</sup> of Berlin conceived the idea that inasmuch as the keratinous tissues were exceptionally rich in cystine, why should it not be a fruitful proceeding to feed hydrolyzed keratin, or cystine, to the bald and thereby abolish man's concern over hirsute, or absence of hirsute, develop-

<sup>1</sup> SMITH, *J. Chem. Soc.*, **46** (1884), 1398.

<sup>2</sup> DREAPER, "Allen's Commercial Organic Analysis," 4th ed. vol. 8 (1913), 675.

<sup>3</sup> SMITH, *loc. cit.*

<sup>4</sup> DREAPER, *loc. cit.*

<sup>5</sup> Official German Pharmacopœa 3rd ed.

<sup>6</sup> ZUNTZ, *Deut. med. Wochschr.*, **46** (1920), 145.

ment. Professor Zuntz first experimented upon himself, and in his report stated that whereas before he had begun his experiments his average growth of hair on his head and face had been 5 mg. per day, after treatment for 2 months, during which time he consumed from 1 to 1.5 g. of hydrolyzed keratin daily, his average growth of hair had increased to 9.22 mg. He extended his investigation to others and reported that two youths who had become nearly bald due to the war were greatly benefited, but another became disgusted with the treatment since it made it necessary for him to shave twice a day. On applying the experiment to sheep Professor Zuntz found that the yield of wool was increased to 174 per cent of the original production, and the diameter of the individual wool fibers increased one-third.

The idea was at once exploited by a German firm who put two preparations of hydrolyzed keratin, or *Humagsolan*, on the market: one to be used by man and the other by sheep.

A test of the efficacy of such treatment was made by Fuchs<sup>1</sup> in Vienna upon fifteen men and two women, but his experiments failed to confirm those of Zuntz. The Journal of the American Medical Association<sup>2</sup> also is inclined to regard the proposition with amusement, albeit the record of Professor Zuntz entitles the subject to a thorough test.

**4. Elastin.**—The connective tissues of the higher animals contain a large amount of the protein known as *elastin*. The cervical ligament, *ligamentum nuchæ*, of the ox contains as much as 74.6 per cent of its dry weight of elastin. Other forms of connective tissue contain much less elastin, but it is present to the extent of 4.4 per cent in the dry matter of the Achillis tendon of the ox.

Elastin is a simple protein belonging to the albuminoid class. Its elementary composition is given below.

It has been a matter of dispute whether or not sulphur was a necessary constituent of elastin. Schwarz obtained a small amount of sulphur from the elastin of the aorta, but he found it could be removed by the action of alkalis without altering the properties of the substance. It is generally conceded, however, that sulphur is a constituent part of the elastin molecule.<sup>3</sup>

The amino-acid constitution of elastin is given in the table on

<sup>1</sup> FUCHS, *Weiner. klin. Wochschr.*, **33** (1920), 707.

<sup>2</sup> *J. Am. Med. Assn.*, **75** (1920), 676; 748.

<sup>3</sup> See RICHARDS and GIES, *Am. J. Physiol.*, **7** (1902).

page 36. An examination of the data will show that the three simple amino-acids, glycine, leucine, and alanine, comprise more than 50 per cent of the elastin molecule. It will be recalled that gelatin is also very high in glycine, but the latter protein differs from elastin in containing only 7.1 per cent of leucine as compared with more than 21 per cent of that amino-acid in elastin. This protein is also rich in phenylalanine, but very poor in the diamino-acids and the hexone bases. This fact has been used as an argument against the existence of the elastin molecule as a unit substance.

TABLE 21.—ELEMENTARY COMPOSITION OF ELASTIN

Source	Carbon	Hydrogen	Nitrogen	Sulphur	Oxygen	Observer
Elastin from <i>ligamentum nuchæ</i> .	54.32	6.99	16.75	....	21.94	Horbaczewski <sup>1</sup>
Elastin from <i>ligamentum nuchæ</i> .	54.24	7.27	16.70	....	21.79	Chittenden and Hart <sup>2</sup> .
Elastin from the aorta.....	53.95	7.03	16.67	0.38	....	Schwarz <sup>3</sup>

<sup>1</sup> HORBACZEWSKI, *Z. physiol. Chem.*, **6** (1882), 330.

<sup>2</sup> CHITTENDEN and HART, *Z. Biol.* **25** (1889).

<sup>3</sup> SCHWARZ, *Z. physiol. Chem.*, **18** (1894), 487.

When elastin is partially hydrolyzed by the action of proteolytic enzymes, superheated water, or dilute acids, two proteoses are obtained which have been called by Chittenden and Hart<sup>1</sup> *proteoelastose* and *deuteroelastose*. The two are distinguished by differences in solubility, the former being the less soluble and separating out upon boiling in water. It is precipitated by acids and potassium ferrocyanide. The latter is not acted upon by these reagents.

Pure elastin is a yellowish-white powder, when dry, and in the moist condition is stringy and tacky. It does not dissolve in water, alcohol, or ether, nor in dilute acids or alkalis. When heated with stronger acids, however, it goes readily into solution. Strong caustic alkalis dissolve elastin only with difficulty and upon heating. Elastin responds to the test with Millon's reagent, and to the xanthoproteic reaction.

Elastin is best prepared from the *ligamentum nuchæ* by freeing the ligament of other proteins. This is best accomplished by

<sup>1</sup> CHITTENDEN and HART, *loc. cit.*



boiling with successive portions of water, 1 per cent caustic potash, water, and acetic acid. The residue is then treated for 24 hours with cold 5 per cent hydrochloric acid, again washed and boiled with water, and lastly treated with alcohol and ether. The residue, dried and powdered, is practically pure elastin.

**5. Mucins and Mucoïds.**—The *mucins* are found to occur generally in the skins of the amphibia and of the fishes, and are an important constituent of the saliva, the tendons, connective tissue, cartilage, skin and the umbilical cord of vertebrate animals. These proteins are found also in the skin secretions of snails. Similar substances occur frequently in the shell-like coverings of the invertebrates. The mucins belong to the class of *conjugated proteins*, and to the sub-group *glycoproteins*. That is, they contain both a protein and a carbohydrate group in their molecule. The carbohydrate moiety consists probably of chondroitic acid.

The *mucoïds* are very similar to the mucins, but present a slightly different set of properties, and therefore have been given a distinguishing name. The true mucins are described as giving a mucilaginous and ropy solution in water, or water containing a trace of alkali, and giving a precipitate with acetic acid which is not soluble in an excess of the acid. The mucoïds, on the other hand, do not produce mucilaginous and ropy solutions, and the precipitate obtained with acetic acid is soluble in an excess of the acid. The chemical basis of differentiation has not been satisfactorily accounted for. The mucoïds show a higher sulphur content than the mucins, and they occur probably as the calcium salt, while the mucins exist chiefly in the form of the potassium salt.

The elementary composition of mucins and mucoïds obtained from different sources is given below.

In a study of the hydrolysis of mucoïd obtained from tendons Levene<sup>1</sup> found that with dilute acids the mucoïd was decomposed into galactose, galactosamine, and sulphuric acid, and with stronger acids he obtained leucine, tyrosine, levulinic acid, and acetic acid. Chondroitic acid was also decomposed into glucosamine, or levulinic acid derived from it, glycuronic acid, sulphuric acid, and acetic acid. Since the same cleavage products are obtained by the hydrolysis of mucoïd as are derived from chondroitic acid it was a natural inference that chondroitic acid, or a very similar

<sup>1</sup> LEVENE, *Z. physiol. Chem.*, **31** (1900), 395.



TABLE 22.—ELEMENTARY COMPOSITION OF MUCINS AND MUCOIDS

Source	Carbon	Hydrogen	Nitrogen	Sulphur	Oxygen	Observer
Mucin from saliva . . . . .	48.26	6.91	10.70	1.40	. . . . .	Müller <sup>1</sup>
Mucin from submaxillary	48.84	6.80	12.32	0.84	41.30	Hammerstein <sup>2</sup>
Mucin from snail . . . . .	50.32	6.84	13.65	1.75	27.44	Hammerstein <sup>2</sup>
Mucoid from tendon . . .	47.47	6.68	12.58	2.20	31.07	Cutter and Gies <sup>3</sup>
Mucoid from cartilage . . .	47.30	6.42	12.58	2.42	31.28	Mörner <sup>4</sup>
Mucoid from ossein . . . .	47.07	6.69	11.98	2.41	31.85	Hawk and Gies <sup>5</sup>

<sup>1</sup> MÜLLER, *Z. Biol.*, **42** (1901).

<sup>2</sup> HAMMERSTEIN, *Z. physiol. Chem.*, **12** (1888), 163

<sup>3</sup> CUTTER and GIES, *Am. J. Physiol.*, **6** (1901), 155.

<sup>4</sup> MÖRNER, *Skand. Arch. Physiol.*, **1**.

<sup>5</sup> HAWK and GIES, *Am. J. Physiol.*, **5** (1901), 388.

substance, constitutes the prosthetic group of mucoid. Chondroitin acid is also one of the major constituents of cartilage, which fact brings the mucins and cartilages into a close chemical relationship. It is also of interest to the biochemist that chitin, the principal constituent of the hard parts of the anthropoda, also yields on hydrolysis glucosamine, acetic acid, and sulphuric acid. From these analogies it would seem that chitin, cartilage, and mucin are closely related from an evolutionary point of view, and this relationship has been the basis of a theory by Gaskell and Putten to the effect that the anthropods were the ancestors of the vertebrates. The chitin is considered as having combined with glycuronic and sulphuric acids to form the matrix of the mucin, mucoid, and cartilage of the vertebrates.

The reactions of chondroitin acid may be written as follows:

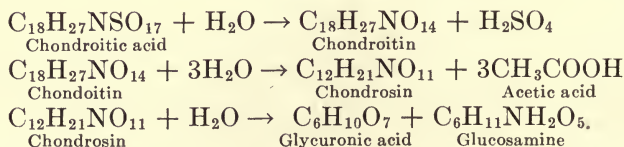

The terms *chondromucoid*, *tendomucoid*, *osseomucoid*, etc., are used to designate the source of the mucoid in question, the above referring respectively to the mucoid obtained from cartilage (chondro- signifying cartilaginous), from tendons, and from the organic matrix of bones (os- meaning bone). The term *chondro-*

*protein*, however, refers to a conjugated protein in which the prosthetic group is chondroitic acid.

The mucins are not all equally resistant to chemical decomposition. Some, as the submaxillary mucin, are readily affected by very dilute alkalies, as lime water, while others, as tendomucoid, are not altered by such treatment. If the strength of the alkali be increased to the equivalent of 5 per cent of potassium hydroxide the submaxillary mucin will be decomposed into alkali albuminate, proteose- and peptone-like substances, and acid organic substances. Submaxillary mucin is soluble in very dilute hydrochloric acid, while the mucin obtained from snails and from the saliva is not soluble. The precipitates obtained with acetic acid differ also, that from saliva being flaky while the submaxillary mucin is thrown down by acetic acid in tough fibrous masses.

In many respects, however, the properties are similar for all mucins. In the moist condition they form tough rubbery lumps. On drying they form a white or slightly amber or grayish colored powder. They are insoluble in water or dilute acids, but if traces of alkali are present they will go readily into solution and, due to the natural acidity of their molecule, if the alkalinity of the water solution is not greater than a certain small value, the solution resulting may be perfectly neutral. Most acids will throw the mucin out of solution but, as the precipitate is soluble in an excess of strong acid, acetic acid is ordinarily used for this purpose. The presence of 5 to 10 per cent of sodium chloride will, however, prevent precipitation by acetic acid. Tannic acid does not ordinarily precipitate mucin, but if added to the salt-acetic acid solution, a heavy precipitation results. Potassium ferrocyanide added to a similar solution makes it highly viscous. Alcohol has no effect upon mucin in a neutral water solution, but if salts are present the mucin will be thrown out. Typical protein coagulation does not, however, take place by the action of any of the above reagents, nor by boiling with water. Lead acetate and alum may be used as precipitating agents. The mucins react in the usual way to the Millon's and Adamkiewicz' reagents, but yield a rose-red coloration with the biuret test.

Landwehr<sup>1</sup> found that by the action of superheated steam or alkali a complex carbohydrate, which he called *animal gum*, was

<sup>1</sup> LANDWEHR, *Z. physiol. Chem.*, 8 (1884), 122; 9 (1885), 361.

split off. Other investigators<sup>1</sup> have failed to confirm this finding, but have obtained instead a nitrogenous carbohydrate.

Mucin is best obtained from the submaxillary glands by extracting the macerated glands with water. The filtrate is treated with 25 per cent hydrochloric acid until the solution contains 0.15 per cent of the acid. A precipitate which appears on the first additions of acid redissolves as more acid is added. The mucin is then thrown out of solution by pouring into two or three volumes of water. Mucin from other sources, as the tendon, is best prepared by extracting with lime water and precipitating with acetic acid. The material is purified by repeated solution in dilute alkali and precipitation with acetic acid.

Mucin is of an unusual personal interest to the human race through its functions as a salivary secretion and from the fact that two of the most prevalent diseases of the teeth, *e.g.*, *dental caries* and *salivary calculi*, are the result of its chemical behavior. The physiological function of mucin in the mouth appears to be associated with the "buffer action"<sup>2</sup> which it possesses. That is, mucin is capable of reducing the acidity of fruit juices or other acids introduced into the mouth to a point where such acids are no longer injurious to the teeth. If mucin were not present these acids would in the course of years seriously corrode the teeth and render them valueless. The film of mucin protects them from this disaster.

But although acids introduced as such are largely inhibited in their solvent action, the mucin cannot prevent particles of food from becoming lodged between the teeth and in protected spots at the margin of the gums. These food particles, especially the carbohydrates, are attacked readily by the bacterial flora of the mouth and upon fermentation produce organic acids. Dental caries is primarily a decalcification of the enamel and dentin of the tooth by such organic acids.<sup>3</sup> In order, however, for the bacterial action to be effective there must not only be particles of food lodged in the teeth, but also a protective covering of "mucoid plaque" by which acids formed are held against the tooth and protected from dilution and neutralization by the salivary secretions. Under this mucoid plaque the process of acid production and enamel dissolution may go on unmolested with the result that a lesion in the tooth is accomplished.

<sup>1</sup> Cf. HAMMERSTEIN, *ibid.*, 12 (1888), 163; and FOHN, *ibid.*, 23 (1897), 347.

<sup>2</sup> See page 587.

<sup>3</sup> BUNTING, "Ward's American Textbook of Operative Dentistry," p. 136.

Tartar or salivary calculi that becomes deposited on the teeth is composed of "masses of tricalcium phosphate and calcium carbonate built upon a mucinous or colloidal matrix and arranged in concentric layers about a central nidus." When first deposited the flaky white precipitate is soft and viscous, insoluble in water, but easily removable by a brush or finger. This soon becomes hard and not easily removable. The calculi is supposed to be produced by precipitation of the mucin from the saliva by means of the acids resulting from fermentation of food particles, or by the free acid of fruits, etc. The phosphates and carbonates of calcium that are present in the saliva are carried down and deposited with the mucin.

The customary practice of tooth preservation lies in the removal of these mucinous precipitates and films by means of brushing with an abrasive as precipitated chalk, mixed with a little soap. A far more scientific procedure would be to dissolve the precipitated mucin and mucinous films by some solvent. Any alkali or alkali salt of a weak acid of a pH value<sup>1</sup> of 10.5 to 11.0 is found to be a ready solvent for mucin. The extraordinary efficiency of the liquid dentifrice recently prepared by Vogt<sup>2</sup> is attributable to the scientific adaptation of this principle.

**6. Chondrigin and Chondrin.**—In 1900 and as late as 1910 the terms chondrigin and chondrin were in common usage. *Chondrigin* was considered to be the principal albuminoid constituent of the matrix of hyaline cartilage and, upon boiling with water, to slowly go into solution with the formation of *chondrin*. The chondrigin was described as a substance quite analogous to collagen, but somewhat less soluble in water and possessing many of the reactions of mucin. On cooling an aqueous solution of the chondrigen a jelly was produced, but it possessed less strength than an equivalent one of gelatin.

In 1893 the researches of C. Mörner<sup>3</sup> and of Morochowetz<sup>4</sup> indicated that what had been regarded hitherto as chondrigin was in reality a mixture of *collagen* with other substances, chiefly *chondromucoid*, *albuminoid*, and *chondroitin acid*. These substances have already been described. Mörner in an examination of cartilage found only 16.4 per cent of nitrogen. Gelatin averages about 17.7 per cent nitrogen. By an examination of

<sup>1</sup> See page 581.

<sup>2</sup> C. C. VOGT, personal communication.

<sup>3</sup> C. MÖRNER, *Skand. Arch. Physiol.*, **1**.

<sup>4</sup> MOROCHOWETZ, *Verh. d. naturh. med. Vereins zu Heidelberg*, **1**, Heft 5.



sections of the cartilage under a microscope he found that chondroitin acid and chondromucoid surrounded the cells as spherical shells. These have been known as Mörner's *chondrin-balls*. By staining with methyl-violet he was able to observe that these balls lay in the meshes of a net-like structure of collagen, and by treating these sections with dilute hydrochloric acid, followed by dilute potassium hydroxide, he was able to dissolve out the chondrin balls, leaving the super-structure of collagen. This latter yielded, on boiling with water, a gelatin having all of the usual properties and reactions of such.

Morochowetz examined a number of specimens of cartilage obtained from a variety of sources, and succeeded in separating that material into mucin and gelatin by dissolving out the former with a dilute solution of an alkali. The gelatin obtained by boiling the residue with water possessed the usual properties ascribed to that substance.

These investigations have been confirmed by Krukenberg and Landwehr, but exception is taken to them by Schützenberger and Bourgeois who claim that the products of hydrolysis of chondrin by boiling with barium hydroxide do not contain any glycine whatsoever, and show three times as much acetic acid as ordinary gelatin treated in a similar way. Dawidowski<sup>1</sup> has also considered chondrin as a distinct substance, but convertible to gelatin upon boiling with a caustic alkali.

The material which has been known as chondrin may be prepared by boiling the cartilage of the ribs or larynx for 24 to 48 hours with water, or under pressure at 120°C. for 3 or 4 hours. The undissolved residue, consisting of nonsoluble proteins, elastin, mucin, etc., is filtered off, and the chondrin is precipitated by pouring into a large volume of alcohol. The precipitate may be redissolved in hot water, concentrated, allowed to gel by cooling, and dried similarly to gelatin. The product is a hard, amber-colored, transparent substance, insoluble in cold water, alcohol, or ether. It is differentiated from normal gelatin by being precipitated from solution by mineral acids, organic acids, alum, the sulphates of iron and aluminum, and the acetate and sub-acetate of lead. It resembles gelatin in being thrown out of solution by alcohol, tannin, and mercuric chloride.

✓ **7. Melanins and Humins.**—The *melanins* are dark brown, reddish-brown, or black pigments which are found in hair, in the

<sup>1</sup> DAWIDOWSKI, "Glue, Gelatin, etc.," 2nd ed., Philadelphia (1905), 5.



epidermis of dark-colored animals and races, and in a few other less conspicuous places, as the choroid coat of the eye and in pathological growths, as tumors.

*Humins* have been described as the dark-colored pigments which are usually formed upon the acid-hydrolysis of proteins, and have been variously ascribed as due to the presence of tryptophane, tyrosine, glucosamine, lysine, etc.<sup>1</sup> A combination especially favorable for the formation of humin is the simultaneous presence of tryptophane and a carbohydrate.<sup>2</sup> Whether or not these two groups of pigments are one and the same is a point which has not been settled. The composition and the reactions are very similar, and the tendency of physiological chemists is to regard them as identical, although conclusive evidence to that end is lacking.

The ultimate source of the color of these pigments has been variously attributed to iron, to sulphur, and to particular organic combinations. Many of the melanins contain iron, and considerable work has been done to trace their origin through this element but, since the nucleo-proteins and many albumins also contain iron, and since melanins have been found which were free from iron, no important conclusions could be derived from these investigations. The sulphur content has also been found not only to vary within very wide limits, but a few melanins have been found in which sulphur was absent. In one case the sulphur content was as high as 10.1 per cent. It is possible that such variations may have been due to impurities, for there has been no criteria of purity of the melanins. Extraneous pigments derived from the blood or bile or other sources might easily contaminate the substance despite the utmost care of the investigator.

The intensity of the coloring power of the melanins is very great as may be judged by results obtained by Abel and Davis<sup>3</sup> who found that the skin of an average negro contained only 3.3 g. of pigmentary granules, of which only 1 g. comprised the actual pigment, the balance being a colorless substratum.

The elementary composition of some melanins is shown below.

The melanins are resistant to chemical action, being insoluble in water, alcohol, ether, benzene, neutral salt solutions, and

<sup>1</sup> SAMUELY, *Hofmeister's Beitr.*, **1** (1902), 229.

<sup>2</sup> GORTNER and BLISH, *J. Am. Chem. Soc.*, **37** (1915), 1630; GORTNER and HOLM, *ibid.*, **39** (1917), 2477; **42** (1920), 632; 821.

<sup>3</sup> ABEL and DAVIS, *J. Exptl. Med.*, **1** (1896), 361.

dilute acids. They are readily soluble, however, in alkali or alkali carbonate solutions, from which they may be reprecipitated by neutralization or acidification with acids, and by the addition of lead acetate, magnesium sulphate, or barium hydroxide. Indol, skatol, and ammonia have been obtained<sup>1</sup> from the decomposition products of the melanins, but bases, phenol, cystine, tyrosine, and leucine have not been found.<sup>2</sup> The hydro-aromatic substance, xyliton, has also been isolated by Wolff.<sup>3</sup> The melanins are most satisfactorily extracted from pigmented skin by boiling with dilute alkali (0.05N NaOH for one hour), and precipitated from the solution by the addition of acid (HCl to 0.3N).<sup>4</sup>

TABLE 23.—ELEMENTARY COMPOSITION OF MELANINS

Source of melanin	Carbon	Hydrogen	Nitrogen	Sulphur	Iron	Observer
Human hair.....	56.14 to 57.6	4.2 to 7.57	8.5 to 11.6	2.1 to 4.1	0	Sieber <sup>1</sup>
Horse hair.....	58.44	5.55	11.7	3.64	....	Nencki and Sieber <sup>2</sup>
Skin of negro.....	51.83	3.86	14.01	3.6	....	Abel and Davis <sup>3</sup>
Choroid coat of eye ....	60.34	5.02	10.81	0	....	Sieber <sup>1</sup>
Melanotic sarcoma .....	48.95 to 54.93	4.23 to 5.15	12.58 to 13.02	1.92 to 8.23	0.41	Zdenek and v Zeynek <sup>4</sup>
Sepia.....	56.34	3.61	12.34	0.52	....	Nencki and Sieber <sup>2</sup>

<sup>1</sup> SIEBER, *Arch. expl. Path. Pharm.*, **20** (1885), 362.<sup>2</sup> NENCKI and SIEBER, *ibid.*, **24** (1888), 17.<sup>3</sup> ABEL and DAVIS, *loc. cit.*<sup>4</sup> ZDENEK and v. ZEYNEK, *Z. physiol. Chem.*, **36** (1902), 493.

**8. Amyloid.**—*Amyloid* is usually considered as a protein produced by pathological processes, but Krawkow<sup>5</sup> has shown that it is a normal constituent of old cartilage and of aortæ. Under pathological conditions it is present in the liver, kidneys, and other organs. It has been shown to be an albumin, and in composition is rather high in sulphur, containing about 2.75 per cent of that element. Chondroitin acid was obtained from amyloid by Krawkow which places it in the class of glycoproteins

<sup>1</sup> HOPPE-SEYLER, *Hofmeister's Beitr.*, **5** (1904), 476.<sup>2</sup> NENCKI and SIEBER, *loc. cit.*<sup>3</sup> WOLFF, *Hofmeister's Beitr.*, **5** (1904), 476.<sup>4</sup> YOUNG, *Biochem. J.*, **15** (1921), 118.<sup>5</sup> KRAWKOW, *Arch. expl. Path. Pharm.*, **40** (1897), 195.

with mucin. This constitution has been denied, however, by Cohn.<sup>1</sup>

Amyloid is insoluble in water and salt solutions, alcohol, ether, and dilute acids. In boiling water, especially under pressure, and in dilute alkalies it dissolves readily. Amyloid differs from mucin and keratin in that it will also slowly dissolve in dilute acids. In concentrated acids and alkalies it is soluble with decomposition. Neuberger<sup>2</sup> reports that amyloid is digested by both pepsin and trypsin, but it is usually conceded that pepsin is without effect on the pure material. Amyloid reacts positive to all the usual protein color tests.

**9. Ichthylepidin.**—Mörner<sup>3</sup> has described a protein which he obtained from the scales of certain species of fish, and to which he gave the name *ichthylepidin*. In the scales of the *teleostean* fishes he found it to the extent of 24 per cent, but in the scales of the *elasmobranchs*, the *mola mola*, and the *spheroides maculatus* it was apparently absent. The balance of the organic matter of the scales was found to consist almost entirely of collagen.

Green and Tower<sup>4</sup> have followed up the early work of Mörner, and have analyzed the scales of a large variety of fishes for ichthylepidin. They found that if it was present at all it constituted about one-fourth of the total organic matter of the scales. Some chondroitin acid and guanin was also obtained. The remaining 75 per cent was collagen. It was especially remarked that a great difference exists apparently in the collagen of scales containing no ichthylepidin and of those containing this protein. If ichthylepidin is present the collagen is very loosely combined, a large proportion of it being removed by boiling for two hours, and also by digestion at 40°C. with 0.1 per cent hydrochloric acid. But if ichthylepidin is absent the collagen is very firmly combined, and is dissolved only by long continued boiling (30 to 40 hours), and is much less affected by dilute acid digestion.

From a large number of analyses Green and Tower report the following data. The organic matter of the scales consisted of ichthylepidin 23.74 per cent, and collagen 76.26 per cent.

<sup>1</sup> COHN, *Z. physiol. Chem.*, **22** (1896), 153.

<sup>2</sup> NEUBERGER, *Verh. physiol. Ges.*, (1904).

<sup>3</sup> MÖRNER, *Z. physiol. Chem.* **24** (1897), 125; **37** (1902), 88.

<sup>4</sup> GREEN and TOWER, U. S. Fish Commission, *Bull.* 21 (1901), 97-102.

COMPOSITION OF MENHADEN SCALES

	Air dry		Dried at 105°C.	
Water.....	20.58		0	
Ash.....	32.61		41.07	
Organic matter.....	46.80	{ Ichthy- lepidin 11.11 Collagen 36.69	58.93	{ Ichthy- lepidin 13.99 Collagen 44.94

In its properties, ichthylepidin stands very close to elastin. It is insoluble in cold and hot water, and in dilute acids and alkalis at the ordinary temperature. On boiling with dilute acids or alkalis, or on standing in the cold concentrated solutions, it dissolves. It is digested by pepsin in acid solution and by trypsin in alkaline solution. It reacts positive to the biuret test, to Millon's reagent, and to the xanthoproteic reaction.

In composition it differs from elastin in containing a larger proportion of proline and glutamic acid, but a smaller amount of glycine.<sup>1</sup> It contains a considerable amount of loosely bound sulphur as shown by a blackening of the solution when boiled with alkaline solutions of lead acetate.

#### 10. Comparison of the Properties of Gelatin and Its Congeners.

If the several conspicuous properties of the proteins which have just been described are compared there will be a few which will stand out in each case as more or less characteristic of the protein in question. Gelatin is easily dissolved in hot water (after swelling in cold water) and upon cooling will form a firm jelly even in dilute solutions. (Pure gelatin will form a firm jelly in 1 per cent solution at 10°C.) The only other protein of the group which is soluble in hot water is amyloid, but the latter is dissolved much less readily, and does not set to a jelly on cooling. Gelatin is furthermore the only member that is soluble in dilute acids, and to a solution of which the addition of dilute acids will fail to produce a precipitate. Of the color tests the biuret reaction is the only one that gives a pronounced and undeniable test with gelatin.

Keratin and elastin are characterized by their great resistance to solution. The fish protein, ichthylepidin, should also be included in this class. Pepsin does not attack keratin, but does

<sup>1</sup> ABDERHALDEN and VOITINOVICI, *Z. physiol. Chem.*, **52** (1907), 368.



slowly digest the other two. The color tests of this group are identical. The physical properties of the original material are, however, vastly different, as hair, horn, etc., yellow connective fibers, and fish scales are not physically similar.

Mucin and chondrin are easily differentiated by their content of carbohydrate, by virtue of which they react to Molisch's reagent, and their easy solubility in dilute alkalies and the readiness with which they may be thrown out of such solution by dilute acids. Chondrin, which is by some regarded as a mixture, probably of mucin and collagen, gives most of the positive reactions of both of these proteins. It may be differentiated from mucin by being precipitated with tannic acid.

Melanin is in a class by itself as the only pigmented member of the group. Its solubility closely resembles that of mucin. It gives a negative test to Millon's reagent, but positive to all of the other color tests.

A few of the characteristic tests that have been described are collected in Table 24.

## II. THE TISSUES CONTAINING COLLAGEN AND ITS CONGENERS

**1. The Skin.** *Structure of the Skin.*—The *skin* of all animals is very much alike in most of its essential features. It consists, in all cases, of an outer layer, or epidermis, of a hard, horny, hairy, or scaly material, and an inner layer, or *corium*, which is composed of bundles of fibers, and constitutes what is generally known as the true skin. The epidermis may be very thin and flexible, as in the skin of a child, or very thick and tough, as in the hide of an elephant or a walrus. It may be covered with hair or wool, as are most animals, or it may become flattened and hardened into scales, as in the fishes. Special growths may be evolved from it, as the nails, claws, horns, hoofs, etc.

The skin and its usually abundant crop of hair constitutes the covering for the animal, enclosing the body and affording protection, but it is normally much more than that. It is an organ of respiration, of transpiration and of sense. Numerous measurements have been made by different investigators upon the amount of oxygen absorbed and the amount of carbon dioxide evolved by means of the skin. The results show that, with the exception of the non-scaly amphibia, it is relatively low, when compared with the activity of the lungs in this capacity, but

TABLE 24.—A COMPARISON OF THE PROPERTIES OF GELATIN AND ITS CONGENERS

	Gelatin	Keratin	Elastin	Mucin	Chondrin	Melamin	Amyloid	Ichthy-lepidin
Physical properties:								
Color	Light amber	Brownish yellow	Yellowish white	White, gray, amber	Amber	Black or brown	White	Gray
Swelling	Strong	Weak	Negative	Negative	Weak	Negative	Negative	Negative
Jelly consistency	Strong	Negative	Negative	Negative	Weak	Negative	Negative	Negative
Solubility:								
Cold water	Insoluble	Insoluble	Insoluble	Insoluble	Insoluble	Insoluble	Insoluble	Insoluble
Hot water	Soluble	Insoluble	Insoluble	Insoluble	Insoluble	Insoluble	Soluble	Insoluble
Alcohol and ether	Insoluble	Insoluble	Insoluble	Insoluble	Insoluble	Insoluble	Insoluble	Insoluble
Dilute acids	Soluble	Insoluble	Insoluble	Mostly insoluble	Insoluble	Insoluble	Insoluble	Insoluble
Dilute alkalis	Soluble	Insoluble	Insoluble	Soluble	Soluble	Soluble	Soluble	Soluble
Reaction with:								
Trypsin	Positive	Questionable	Positive	Positive	Positive	.....	Positive	Positive
Pepsin	Positive	Negative	Positive	Positive	Positive	.....	Negative	Positive
Acetic acid	Negative	Precipitate	Precipitate	Ppt. insol. in excess	Ppt. insol. in excess	Precipitate	Precipitate	Precipitate
Dilute mineral acids	Negative	Precipitate	Precipitate	Ppt. insol. in excess	Ppt. insol. in excess	Precipitate	Precipitate	Precipitate
Boiling with acids	Hydrolyzed	Dissolved	Dissolved	Syntonin produced	Syntonin produced	Hydrolyzed	Hydrolyzed	Dissolved
Strong acids	Hydrolyzed	Dissolved	Dissolved	Hydrolyzed	Hydrolyzed	Hydrolyzed	Hydrolyzed	Hydrolyzed
Strong alkalis	Hydrolyzed	Decomposed	Dissolved	Hydrolyzed	Hydrolyzed	Decomposed	Hydrolyzed	Hydrolyzed
Tannic acid	Precipitate	.....	.....	Negative	Precipitate	.....	.....	.....
Lead acetate	Negative	.....	.....	Precipitate	Precipitate	Precipitate	.....	.....
Protein tests:								
Biuret	Positive	Positive	Positive	Positive (rose)	Positive	Positive	Positive	Positive
Millon's	Faint	Positive	Positive	Positive	Positive	Negative	Positive	Positive
Xanthoproteic	Faint	Positive	Positive	Positive	Positive	Positive	Positive	Positive
Adamkiewicz	Negative	Negative	Negative	Questionable	Negative	Positive	Positive	Negative
Molisch	Negative	Negative	Negative	Positive	Positive	Positive	Positive	Positive
Sulphur	Negative	Positive	Positive	Positive	Positive	Positive	Positive	Positive
Principal decomposition products	Glycine	Leucine	Glycine	Leucine	Leucine	.....	Leucine	.....
	Arginine	-Cystine	Leucine	Phenylalanine	Glycine	.....	Arginine	.....

although the amount is small, it is none the less important, and the body will not suffer serious interference with this function without disastrous consequences. The work of Zuntz<sup>1</sup> shows that the skin respiration equals about  $2\frac{1}{2}$  per cent of the simultaneous lung respiration. In transpiration, or the elimination of water and watery solutions from the body, the skin is highly

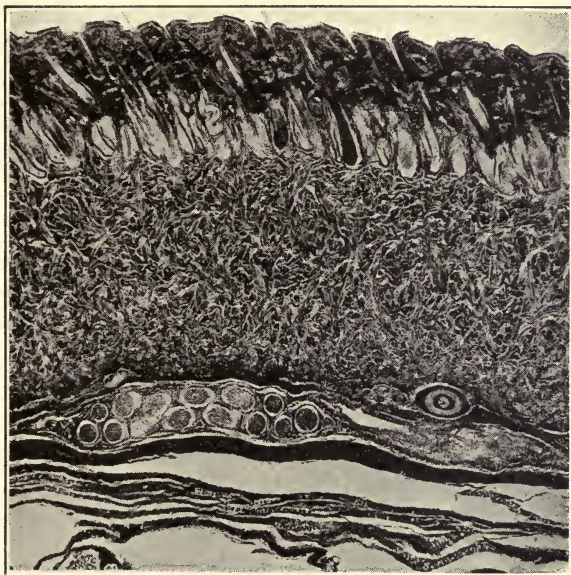

FIG. 13.—Section of fresh untreated calf skin. 25 diameters. (Kindness of John Arthur Wilson, A. F. Gallun & Sons Co., Milwaukee.)

important, it having been shown<sup>2</sup> that 17 per cent of the total water excreted by the body is evolved through the skin.

The epidermis is very thin in comparison with the corium. It is composed, as reference to the accompanying figure will show, of two layers, the under one of which rests upon the corium. This under layer, the *rete malpighi*, is composed of living cells, but as they approach the surface they dry out, become flattened and form, eventually, the hard horny layer at the surface. This is, in turn, being constantly worn away, and replaced by fresh material. The hairs are developed in the under layer of the epidermis by a downward growth, but not until they have penetrated deeply into the corium do they break through the surface.

<sup>1</sup> ZUNTZ, *Arch. ges. Physiol.* (1894).

<sup>2</sup> Cf. MATHEWS' "Physiological Chemistry" (1916), 682.



The *sebaceous*, or *fat glands*, and the *sudoriferous*, or *sweat glands*, are also formed in the *rete malpighi* of the epidermis. Each hair is provided, furthermore, with a small involuntary muscle, called the *erector pili*, which is caused to contract by cold or by fear, causing the hairs to "stand on end," and producing "goose flesh." The quills of the porcupine are in fact only an exaggerated kind of a hair, and the muscles controlling them more highly developed than those in other animals, and are probably voluntary.

The epidermis is separated from the corium by a very fine membrane, called the *pars papillaris*, and known to tanners as the glassy layer which is responsible for the "grain" of leathers.

The *corium* or *true skin* is of an altogether different nature from the epidermis just described. It is composed for the most part of long tender fibers. Sometimes these lie in one plane and are parallel, and in what might be called well-ordered layers, but frequently, especially near the surface, the fibers seem to be interwoven into a hopeless tangle and are very tightly packed. The central portion is often loose, and contains a greater proportion of fat globules, while on the flesh side, as well as near the surface, the fibers are more closely interwoven.

The white fibers which constitute by far the greater part of the corium are of the material known to physiologists as *white connective tissue*. In addition to this the corium contains also a small proportion of fibers of a different nature. These are yellow, very elastic, and are known as *yellow connective tissue*. They are easily differentiated by the fact that they do not swell in a mixture of equal parts of water, glycerine, and acetic acid, while the white fibers become swollen and transparent.

On many animals, as the ox and horse, the corium is covered on its under side with a layer of voluntary muscle. This is removed with the hide, in the slaughter houses, but is usually separated from the hide in the fleshing process, and constitutes one of the important raw materials for the manufacture of glue.

*The Composition of the Skin.*—The foregoing description will serve to show that the skin is by no means a simple substance, but rather a mixture of a number of components which, by specialization along varying lines, have resulted in the formation of the various types of surface growths.

The *epidermis*, *hair*, *horns*, *hoofs*, etc., are composed almost entirely of keratin. This has been described on page 63.



They are easily dissolved by caustic alkalies, but in the depilatory processes of the tannery it is necessary to remove the hair without impairment to the hide. This is most readily accomplished by treatment with alkaline sulphides, which easily dissolve the hair but do not attack the connective tissue of the corium. Solution of the keratin may also be attained by heating in water for prolonged periods, especially under pressure.

The solution resulting has, however, no jellying power, and must be considered as an adulterant of no value if present in gelatin or glue. The statement has so often been found, that horns and hoofs are an important source of glue stock, that it should be emphatically pointed out that this is not the case.<sup>1</sup> This misstatement may have found its origin in that the old time glue makers put into the glue kettle everything from the animal carcass for which they could not find use elsewhere; or it may have been given credence from the loose usage of the term "buckhorn" which is stated, even by Dawidowski,<sup>2</sup> to be an important source of gelatin. Properly speaking, buckhorn is the antler material of sheep, but this substance, and certain hard bones of the ox, as the lower shin bone, have both been used for the preparation of buttons, knife handles, piano keys, etc., and the name of the former has been unfortunately appropriated by manufacturers and dealers of the latter less desirable material.

Besides the keratin of the epidermis, there are of course several other substances present in small amounts. The fat glands are in this layer, and the sweat glands, with their fatty and salty excretions, and the linings of the tubes are of an albuminous material.

The corium, as has been previously stated, consists mainly of white connective tissue, with fibers of the yellow variety scattered through it. These tissues are described on page 84. Albumin is also present in the corium in small amounts, but in the fleshings which are cut from the corium and which contain the muscles underlying the skin, the amount of albuminous material may be large. The albumins are easily coagulated by heating in solution to about 70 or 75°C. The presence of acids lowers the temperature of coagulation, while the presence of alkalies raises it. Coagulated albumins will not readily pass again into solution, and they resemble the keratins in their solubilities.

Another substance intermediate between hide-fiber and gelatin

<sup>1</sup> We refer only to the outer horny portion. The inner portion of horns, called the *pith*, is prized as a high grade of glue or gelatin stock.

<sup>2</sup> DAWIDOWSKI, "Glues, Gelatin, etc." (1905), 4.

has been described by Rollet<sup>1</sup> and by Reimer<sup>2</sup> and called *coriin* by the latter investigator. He subjected calf skins to a prolonged treatment with water to remove every trace of soluble substance, and then digested the skins with lime water for 7 to 8 days. On adding acetic acid to the filtered solution a white flocculent precipitate was thrown down. He considered this as the cementing substance which held the fibers together. But he also found that the same portion of hide could be extracted in this manner repeatedly without becoming exhausted, the fibers becoming finer and finer until they could be distinguished only with difficulty. This supports the theory that there exists no distinct cementing material, but only, perhaps, a partially dissolved portion of the fibers themselves, which acts as a binding agent.

The elementary composition of the corium of different animals is given in the following table:

TABLE 25.—ELEMENTARY COMPOSITION OF THE CORIUM

Animal	Carbon	Hydrogen	Nitrogen	Oxygen	Observer
Ox.....	50.2	6.4	17.8	25.4	Von Schroeder and Paessler <sup>1</sup>
Goat and deer.	50.3	6.4	17.4	25.9	
Sheep and dog.	50.2	6.5	17.0	26.3	
Cat.....	51.1	6.5	17.1	25.3	

<sup>1</sup> VON SCHROEDER and PAESSLER, *Dingler's polytech. J.*, **287** (1893), 258.

**2. The Connective Tissue.**—Several varieties of *connective tissue* have been described, but only two of these are of especial interest in their relationship to this study. One of these is commonly known as *yellow connective tissue*, which consists of tough, elastic, yellowish fibers. It is found in tendons, in the walls of blood vessels, in the lungs, and less prominently in other parts of the body. The most conspicuous occurrence of this variety is in the *ligamentum nuchæ* of the ox. The second type, commonly known as *white connective tissue*, is found chiefly in the tendons of the muscles, and quite generally throughout

<sup>1</sup> ROLLET, *Sitz. Akad. Wiss. Wien.*, **39**, 305.

<sup>2</sup> REIMER, *Dinglers polytech. J.*, **205** (1872), 143.

the body, even the fibers in the organic matrix of bone being of that substance. The most abundant source of this variety of tissue is in the *Achillis tendon*.

These two types of connective tissue differ in their chemical constitution mainly in that the white variety consists essentially of the protein *collagen*, 85 per cent of the dry matter being of this material, while the yellow variety is mostly *elastin*, 74.6 per cent being represented by this protein, and only 17 per cent being collagen. The composition of these tissues is shown in the table following.

TABLE 26.—COMPOSITION OF WHITE AND YELLOW CONNECTIVE TISSUE

Constituents	Tendo Achillis of ox <sup>1</sup>		Ligamentum nuchæ of ox <sup>2</sup>	
	Fresh tissue	Dry tissue	Fresh ligament	Dry ligament
Water.....	62.870	.....	57.570	.....
Solids.....	37.130	.....	42.430	.....
Inorganic matter.....	0.470	1.266	0.470	1.100
SO <sub>3</sub> .....	0.031	0.084	0.026	0.062
P <sub>2</sub> O <sub>5</sub> .....	0.039	0.106	0.035	0.081
Cl.....	0.147	0.397	0.136	0.318
Organic matter.....	36.660	98.734	41.960	98.900
Fat (ether-sol. matter).....	1.040	2.801	1.120	2.640
Albumin, globin.....	0.220	0.593	0.616	1.452
Mucoid.....	1.283	3.455	0.525	1.237
Elastin.....	2.633	4.398	31.670	74.641
Collagen (gelatin).....	31.588	85.074	7.230	17.040
Extractives and undetermined.....	0.896	2.413	0.799	1.883

<sup>1</sup> BUERGER and GIES, *Am. J. Physiol.*, **6** (1901), 219.

<sup>2</sup> VANDERGRIFT and GIES, *ibid.*, **5** (1901), 288.

A small amount of mucoid is present in each case, and is present to a greater extent in the white tissue. Except for the differences in content of collagen and elastin, and the slight difference in mucoid, the constitution of the two varieties is much the same.

The collagen, or gelatin, and the elastin and mucoid may easily be separated from these tissues. The methods for such a

separation, and the properties of these proteins, have been described in a previous section.

✓ **3. The Cartilage.**—True *cartilage* is not found in any of the lower animals, except in the internal skeleton of the cartilaginous fishes, but is always present in the vertebrates. The so-called cartilage of the cephalopods and the anthropods is more closely related to chitin. Cartilage is usually formed as cells imbedded in a homogeneous matrix which is produced, in turn, by the cells. As the age of the animal increases, inorganic salts are often deposited and a bony tissue results. This does not always happen, however, for the cartilage of the trachea, and especially the larynx, remains unchanged through life.

Cartilage is very closely related, in chemical constitution, to white connective tissue, and to ossein. Several substances have been found in the material. Mörner,<sup>1</sup> on investigating the cartilages of full grown cattle, reported four constituents were obtained by a partial decomposition of the matrix, namely, *collagen*, which constituted the bulk of the material, *mucoïd*, *chondroitic acid*, and *albuminoid*. The chondromucoïd was very similar in all respects to the tendomucoïd obtained by Buerger and Gies,<sup>2</sup> and has been described. Collagen and chondroitic acid have also been discussed in detail. The chondroalbuminoid was an albuminous material that remained after long treatment with hot water. On boiling with very dilute potassium hydroxide, however, it went easily into solution. The amount of this substance present in collagen is very small, and has been believed to form the lining of the *Haversian canals*, or little tubes in the cartilage and in bone. The albuminoid obtained from cartilage was found, in fact, to resemble very closely the albuminoid from bones. The elementary composition is given below:<sup>3</sup>

	Carbon	Hydrogen	Nitrogen	Sulphur	Oxygen
Chondroalbuminoid....	50.46	7.05	14.95	1.86	26.86
Osseoalbuminoid.....	50.16	7.03	16.17	1.18	25.46

<sup>1</sup> MÖRNER, *Skand. Arch. Physiol.*, **1**.

<sup>2</sup> BUERGER and GIES, *loc. cit.*

<sup>3</sup> HAWK and GIES, *Am. J. Physiol.*, **5** (1901), 388.



**4. The Bones.**—The *bones* are made up of cells which are enclosed in an intercellular matrix. The cells have received very little study, but have been shown to yield no gelatin and to contain no keratin.<sup>1</sup> The intercellular substance is present in great excess over the cellular, and is composed of two chief constituents: an organic substance which is known as *ossein*, and a heavy inorganic deposit of *mineral salts*.

The ossein may be readily obtained by dissolving out the inorganic salts with dilute hydrochloric acid. It comprises about 60 per cent of the dry matter of bone, 40 per cent being inorganic material. The ossein is not a definite chemical substance, but has been shown to consist of three proteins: *collagen*, *osseomuroid*, and *ossalbuminoid*. The latter two substances are present only in small amounts, by far the greater portion of the ossein consisting of collagen, which is easily converted to gelatin on heating with water. Collagen and osseomuroid have already been described. The albuminoid of bones is nearly identical with that obtained from cartilage, and has been described in connection with that substance.

The *marrow* of bones contains widely varying amounts of *proteins*, *fats*, *lecithin*, and *erythrocytes*. The protein portion consists of a *globulin*, a *nucleoprotein*, and *fibrinogen*, besides traces of *albumin* and *protease*.

The *inorganic* material of bones is chiefly *calcium phosphate* and *calcium carbonate*, but small amounts of other salts are also invariably present and must be considered as a necessary part of the bone. The composition of the mineral portion of dry bone is quite constant, and variations found in different parts of the body, or in different species of animals, are not large. The water content varies greatly, and the relation of the organic to the inorganic portion likewise varies, especially with age, the greater amount of mineral salts being found in the older animals, but the dry bone varies but little. An average analysis of the mineral portion of dry bone is given below:

TABLE 27.—COMPOSITION OF INORGANIC MATERIAL OF BONE<sup>2</sup>

	PER CENT		PER CENT
Calcium phosphate.....	85.0	Calcium fluoride.....	0.3
Calcium carbonate.....	10.0	Calcium chloride.....	0.2
Magnesium phosphate.....	1.5	Alkali salts.....	2.0

<sup>1</sup> SMITH, *Z. Biol.*, **19** (1883).

<sup>2</sup> MATHEWS, "Physiological Chemistry," 2nd ed., New York (1916), 637.

Taggart<sup>1</sup> gives the following distribution of matter in fresh bone:

TABLE 28.—COMPOSITION OF FRESH BONE

	PER CENT		PER CENT
Water.....	51.0	Ossein, etc.....	11.4
Fat.....	15.7	Mineral matter.....	21.9

**5. Fish Skins, Scales, Sounds, etc.**—Fish refuse has long been used for the manufacture of glue. Depending upon the degree of refinement of the process, and the care with which the different parts of the fish are separated, the quality of the product will vary greatly.

The pure skin of the fishes is quite similar in most respects to that of the higher animals. The epidermal layer is, of course, free from hairy growths, but the sebaceous or fat glands are often present in great abundance, and the scales constitute a special development of the outer layer. In constitution, the epidermis, and especially the scales, often contain a protein different from that found in the land animals. This was called *ichthylepidin* by Mörner<sup>2</sup> who first investigated the material. He found that in the scales of some varieties of the *Teleostean* fishes as much as 20 per cent was present, while in other varieties of the *Teleosts*, and in the *Ganoids*, it was entirely absent. Keratin also appears to be absent in some cases but present in others. It seems that the hard and insoluble portions of the scales and the epidermis are for the most part a combination of these two proteins, *ichthylepidin* and keratin, in some cases being entirely the one and in other cases entirely the other. *Ichthylepidin* may, in fact, be considered as a modification of the common horny varieties of keratin formed in the skins and horns of animals.

The epidermis of the fishes differs from that of the land animals in containing a large amount of collagen. Mörner reported 80 per cent of collagen in fish scales. Green and Tower<sup>3</sup> report that more than 52 per cent of pure gelatin is industrially obtained from the scales of the menhaden.

<sup>1</sup> TAGGART, "Glue Book."

<sup>2</sup> MÖRNER, *Z. physiol. Chem.*, **24** (1897), 125; **37** (1902), 88.

<sup>3</sup> GREEN and TOWER, U. S. Fish Commission, *Bull.* 21 (1901), 97.

The inner layer or corium of the skin of the fishes is more nearly identical to that of land animals, since in both cases it consists almost entirely of collagen. The physical structure is somewhat different, as in the fishes the layers are often at right angles to each other, and somewhat more distinct, giving to the

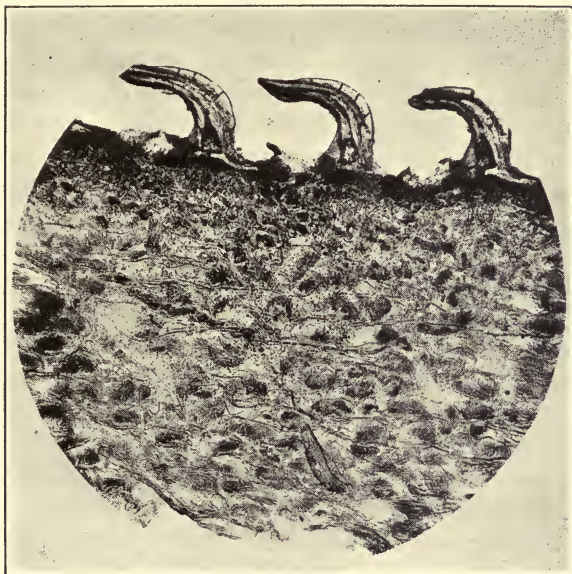

FIG. 14.—Section of shark skin, vegetable tanned. 50 diameters. (*Kindness of John Arthur Wilson, A. F. Gallun & Sons, Milwaukee.*)

skin more of a membranous structure. This is shown clearly in Fig. 14 which shows a section of vegetable tanned shark skin. The collagen in either layer of the skin of the fishes is converted into gelatin much more easily than the collagen in the land animals. Heating for a short time at a low temperature ( $60^{\circ}\text{C}.$ ) is sufficient. The ichthylepidin and keratin are left behind unattacked.

The bones of fishes also contain collagen, but they more nearly resemble the cartilage of animals than the bones, and are thus rich in mucoids, or in what was formerly known as chondrin. In the manufacture of fish glue it has been common practice to put into the glue pot either the whole fish, or the entire refuse from fish canneries, salting factories, and the like. Thus no attempt at a careful separation of material has been commonly made, and in consequence much material other than collagen

has been dissolved and the quality of the product injured. Fatty matter is usually removed from the glue liquor by skimming processes, as fish oils find valuable use in other fields. The residue left in the kettles is dried and made up into fertilizer.

The *sounds*, or air bladders, or swimming bladders, as they are variously called, consist almost entirely of collagen, and have the additional advantage of being exceptionally free from other impurities which might be dissolved out upon heating with water. They also differ from other varieties of collagen in being more readily soluble in warm water than any other type. On account of this unusual purity and the consequent very high quality of the gelatin obtained from them, they have been used for a great many years in the preparation of what is known as *isinglass*.

Many varieties of fish have been used in the preparation of isinglass. The most notable of these is the sturgeon, it being the first fish to be used extensively for commercial isinglass, and its product is still the standard upon which all others are based. It is made up in several ways, which will be described later, and large amounts are still exported from Russia. Catfish and carp also contribute to the Russian product. Many other countries produce sounds, usually of somewhat inferior quality to the Russian. Cod and ling sounds are obtained from Iceland, cod sounds from Norway, miscellaneous types from Venezuela, Brazil, Penang and Bombay. In America, especially in the Canadian waters, sounds are obtained mainly from the hake, cod, squeteague, and more recently the tilefish.



## CHAPTER III

### THE PHYSICO-CHEMICAL PROPERTIES AND STRUCTURE OF GELATIN

Life is so completely linked to the chemical and physical properties of proteins that the knowledge of these properties must precede the attempt at unraveling the dynamics of living matter. Jacques Loeb (1921)

	PAGE
I. The Physico-Chemical Properties of Gelatin.....	91
1. The Diffusion of Gelatin.....	91
2. The Dialysis of Gelatin.....	95
3. The Osmosis of Gelatin.....	97
4. The Vapor Pressure.....	104
5. The Boiling Point and Freezing Point.....	106
6. The Molecular Weight.....	107
7. The Surface Tension.....	114
8. The Optical Rotation.....	116
9. The Index of Refraction.....	119
10. The Gold Number.....	121
11. The Tyndall Effect and Ultramicroscopy.....	123
12. The Donnan Equilibrium.....	128
II. The Structure of Gelatin.....	132
1. The Older Theories of Gel Structure.....	132
2. The Recent Theories of Gel Structure.....	136
3. The Theories of Sol Structure, and the Sol-Gel Equilibrium... ..	145

#### I. THE PHYSICO-CHEMICAL PROPERTIES OF GELATIN

**1. The Diffusion of Gelatin.**—Diffusion is observed in solutions of gelatin much the same as in crystalloidal solutions except that the rate at which it takes place is much slower in the former instance. If a gelatin solution is placed at the bottom of a test tube and a little water carefully poured over the gelatin, the latter will, in the course of time, gradually permeate the water and a homogeneous solution will result. The actual mechanics of the diffusion process is probably much the same in the two cases, and is explained by the laws of molecular kinetics. It is known that the diffusion coefficients, that is, the rates of molecular migration, are greater at high than at low concentrations in

molecularly dispersed systems,<sup>1</sup> and Zsigmondy<sup>2</sup> has, by actual observation with his ultramicroscope, found that the Brownian movement of colloid suspensions is less in dilute than in concentrated solutions. This would require therefore that the molecules in the one case, or the colloid particles in the other case, must move gradually from an environment of higher to one of lower concentration in order that the energy intensities may remain constant throughout the entire system.

The actual *coefficient of diffusion* may be calculated from the law of Fick:<sup>3</sup>

$$ds = Dq \frac{dc}{dx} dt,$$

where  $ds$  is the amount of diffusing substance which, in the time  $dt$ , passes through a diffusion cylinder of cross-section  $q$ ,  $c$  is the concentration at the point  $x$ ,  $c + dc$  is the same quantity at the point  $x + dx$ , and  $D$  is the diffusion coefficient, a constant expressive of the rate of diffusibility of the substance under investigation. The following table cited from Ostwald<sup>4</sup> shows the diffusion coefficients of several colloids in comparison with certain crystalloid substances:

Substance	Temperature, °C.	$D$	Observer
Sodium chloride.....	20	1.04	Voightländer <sup>1</sup>
Magnesium chloride.....	20	0.77	Voightländer <sup>1</sup>
Cane sugar.....	9	0.31	Graham— Stefan <sup>2</sup>
Egg albumin.....	18	0.059	Herzog <sup>3</sup>
Ovomucoid.....	18	0.044	Herzog <sup>3</sup>
Emulsin.....	18	0.036	Herzog <sup>3</sup>
Invertin.....	18	0.033	Herzog <sup>3</sup>

<sup>1</sup> VOIGHTLÄNDER, *Z. physik. Chem.*, **3** (1889), 329.

<sup>2</sup> GRAHAM—STEFAN, *Sitz. Akad. Wiss. Wien.*, **77**, II (1879), 161.

<sup>3</sup> HERZOG, *Kolloid-Z.*, **2** (1907), 1; **3** (1908), 83.

As a result of an investigation upon the diffusion velocity of

<sup>1</sup> WM. OSTWALD, "Lehrbuch der allgemeine Chemie," 2nd ed. (1903), 686.

<sup>2</sup> R. ZSIGMONDY, *Kolloid-Z.*, Jena (1915), 111.

<sup>3</sup> A. FICK, *Pogg. Ann.*, **94** (1855), 59.

<sup>4</sup> WO. OSTWALD—FISCHER, "Handbook of Colloid Chemistry," Philadelphia (1915), 214.

gold hydrosols of different sizes Svedberg<sup>1</sup> obtained results which Ostwald<sup>2</sup> urges are indicative that the diffusion velocity is approximately inversely proportional to the size of the particles, and he furthermore points out that such a deduction is entirely in harmony with mathematical expressions formulated by Einstein<sup>3</sup> and Smoluchowski<sup>4</sup> which are based entirely upon molecular-kinetic considerations.

*Liesegang Rings.*—A very pretty demonstration of the diffusion

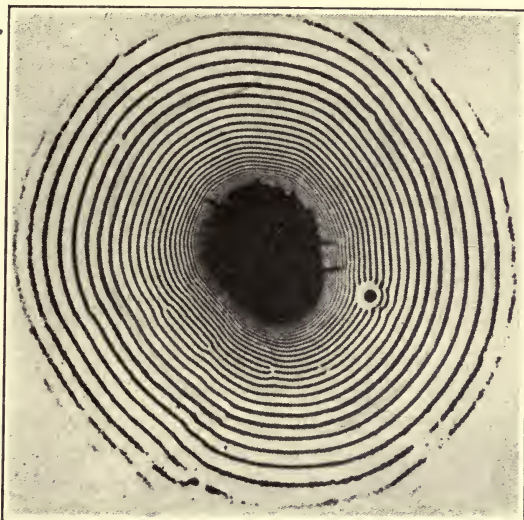

FIG. 15.—Periodic precipitation of silver chromate in gelatin. (R. E. Liesegang.)

of electrolytes into a jelly, known as the *Liesegang ring formation* in honor of its discoverer,<sup>5</sup> is produced by allowing a drop of a solution of a salt, such as silver nitrate, to rest upon a slab of jelly in which has been dissolved another salt, such as potassium bichromate, with which the former salt would normally produce an insoluble precipitate. As the silver ions diffuse outward into the jelly, silver chromate will be precipitated, but instead of a uniform precipitation taking place, very clearly marked rings of precipitate are formed, see Fig. 15.

<sup>1</sup> THE SVEDBERG, *Z. physik. Chem.*, **67** (1909), 105.

<sup>2</sup> WO. OSTWALD, *lib. cit.*

<sup>3</sup> A. EINSTEIN, *Ann. physik.* (4), **21** (1905), 17, 549.

<sup>4</sup> M. VON SMOLUCHOWSKI, *ibid.*, **21** (1906), 756.

<sup>5</sup> R. E. LIESEGANG, *Z. anal. Chem.*, **50** (1910), 82; *Kolloid-Z.*, **12** (1913), 74; 269.

The experiment may be varied greatly. By carrying out the work in a test tube as many as twenty parallel membranes may be formed. The phenomenon varies, however, with the salt used and the nature of the jelly.<sup>1</sup> For example, silver nitrate and potassium bichromate give these rings in gelatin jelly but not in agar, while lead nitrate and potassium chromate give them in agar but not in gelatin. Neither of these combinations give rings in silicic acid, though some others do. Sodium chloride does not produce rings of precipitate in gels with silver nitrate, but instead a continuous band results, as also results by the use of lead nitrate and potassium chromate in gelatin.

Microscopic examination shows that in most cases the rings contain a large number of small, and the clear spaces a small number of large crystals or crystalline aggregates. A striking microscopic illustration is shown by the action of cadmium sulphide in silicic acid gel, which exhibits no clear spaces at all, but instead a succession of alternately pink and yellow bands. The two shades are known to be due to differences in the size of the particles, and either may be obtained by the precipitation of aqueous solutions of different concentrations.

Wm. Ostwald<sup>2</sup> offered an explanation for the Liesegang ring formation based upon the assumption of *metastable supersaturation*. As the silver nitrate diffuses into the bichromate gelatin, silver chromate is formed but remains in solution in a supersaturated condition until the upper limit of metastability is reached. At this point silver chromate is precipitated and the supersaturated solution adjacent is likewise deposited reinforcing the first deposition.

Hatschek discredited the conception of a highly supersaturated and metastable solution by disseminating crystalline lead iodide in an agar gel containing also potassium iodide. On placing a solution of lead nitrate in contact with this gel, the rings formed in the usual manner, but the presence of the crystalline nuclei of lead iodide should have made supersaturation impossible.

Bradford<sup>3</sup> explains the rings as due to an adsorption of one of the reacting solutes by the layer of precipitate, resulting in parallel zones practically free from it. This theory possesses the advantages of simplicity but we should like to have more

<sup>1</sup> E. HATSCHKEK, 2nd Report on Colloid Chemistry (1919), 21.

<sup>2</sup> WM. OSTWALD, "Lehrbuch Allg. Chemie," 2nd ed., vol. 2, 778.

<sup>3</sup> S. C. BRADFORD, *Biochem. J.*, **10** (1916), 169; **11** (1917), 14.



direct evidence that adsorption actually does take place in certain instances and not in others before accepting it. Also one would be led to inquire why adsorption of a given solute by a given precipitate should take place in one type of gel and not in another. Holmes<sup>1</sup> has proposed a theory along somewhat similar lines.

Hatschek regards Freundlich's suggestion that the formation of periodic strata may be an instance of the coagulation by electrolytes of a suspensoid sol as the most important hypothesis yet advanced to account for the Liesegang ring formation. If coagulation by electrolytes is a deciding factor, then the formation of strata must be dependent in large measure upon the protective influence of the gel. In the cases cited, the protective effect of gelatin and agar is about as 100 to 2, and that of silicic acid is negligible. According to these data we should not expect precipitation of the rings to be similar in the three gels.

The formation of banded agates and other minerals is generally ascribed to similar diffusional phenomena as described above, but Bechhold<sup>2</sup> claims that diffusion is not necessarily involved since somewhat similar structures may be produced in jellies by crystallization of water or sodium phosphate in them.

**2. The Dialysis of Gelatin.**—It was early observed by Thomas Graham that those substances which diffuse easily through water or other solution also pass freely through parchment paper or animal membranes, while, on the other hand, the substances which diffuse very slowly are restrained by such membranes. As will be pointed out in the following chapter, this separation formed the basis of the distinction between crystalloids and colloids, and marked the beginning of the chemistry of colloids.

There are two explanations which are generally used to account for the fact that certain membranes are permeable to substances in the molecular state of subdivision while not to colloiddally dispersed substances. The older of these is sometimes spoken of as the *sieve theory*. This, as the name applies, conceives the membrane under consideration as consisting of a large number of small capillary pores of such dimensions that the small crystalloidal molecules may pass freely through, while the larger colloidal aggregates are sufficiently large to be held back. There is a great deal of evidence in favor of this conception. For

<sup>1</sup> H. HOLMES, *J. Am. Chem. Soc.*, **40** (1918), 1187.

<sup>2</sup> BECHHOLD, "Colloids in Biology and Medicine" (1919), 261.

example, gold sols may be prepared of various sizes from the order of molecular dispersoids to suspensions. The smaller of these pass readily through parchment paper while the larger sizes are restrained. The principle of ultrafiltration makes use of the same conception. Porous porcelain cylinders may be prepared of varying degrees of pore dimension, and upon filtering colloid sols through these, varying degrees of separation are obtained, just as the passing of sand through a series of sieves will separate the material into varying sized grains.

The other theory of semipermeability rests upon the belief that the membrane is permeable only to those substances which may be *dissolved* by it. This is most easily understood by the consideration of a two-phase system in which one of the phases, at least, is a pure liquid, such as a solution of sugar in water. A collodion membrane, for example, will readily dissolve water, but not sugar. So, if such a membrane be permitted to separate a solution of sugar in water from pure water, the latter, by being soluble in the membrane, may pass freely in either direction, while the sugar molecules may not pass the barrier. But since the *water* is the more concentrated on the side of the pure solvent, the membrane will become *supersaturated* with water in respect to the solution, and equilibrium will necessitate that under these conditions more water will pass from the membrane to the solution in any given time than from the solution to the membrane. That is, a passage of water will take place from the pure solvent to the solution side of the membrane. In an entirely similar way a rubber film may function as a semipermeable membrane for solvents like benzene, pyridine, etc., which are soluble in rubber. Likewise a film of water may be used as a semipermeable membrane to separate a mixture of hydrogen which is not soluble in the water, and ammonia gas which is soluble.<sup>1</sup> In the dialysis of colloids, whereby they are separated from crystalloids, the sieve conception is usually regarded as most probable, while in the case of membranes which permit only of the passage of a pure liquid, the solution theory is generally accepted.

A number of different types of membrane have been used in dialysis. Ordinary parchment paper is very satisfactory and is strong. Spécial *diffusion thimbles* are made of this material by most filter paper houses. Fish bladders or animal bladders are

<sup>1</sup> L. KAHLBERG, *J. Phys. Chem.*, **10** (1906), 141.

sometimes used. For investigational work collodion membranes have been found very adaptable. These are made by coating the interior of a flask or tube of any desired size with a 10 per cent solution of nitrocellulose in equal parts of alcohol and ether.<sup>1</sup> The flask is slowly rotated as the material is allowed to run out, and a current of air passed in until the film is dry. By immersing in hot water the film easily separates from the glass wall, and may be drawn out. Membranes made in this way make excellent containers for use in dialyzing due to their very ready permeability to crystalloids and their large surface exposed; and have been used in comparative osmotic pressure investigations with marked success.<sup>2</sup>

Gelatin may also be dialyzed by permitting the gelatin jelly to function as its own membrane. To do this with success a rather stiff jelly is made, cut into thin slices, and suspended in water which is not warmer than 10°C. The water must be frequently changed, or continuously changing.

**3. Osmosis of Gelatin.**—The concept of the free diffusion of molecularly or otherwise dispersed substances from a condition of greater to one of lesser concentration of the solute, as described above, necessitates the assumption of a force which is directive in character and, if opposed, would be measurable by the development of a pressure. Such an opposition to the movement of the dissolved particles, while scarcely affecting the movements of the solvent is obtained by the interposition of a semipermeable membrane between the solution and the solvent. The dissolved molecules are not able to penetrate the membrane, but the force which is accountable for their diffusion is reflected, under these circumstances, in the only alteration in the system which is compatible with the restoration of an equilibrium, namely, the entrance of more of the solvent into the solution, thereby diluting the solution and diminishing the potential difference between solvent and solution. Nernst,<sup>3</sup> Stieglitz,<sup>4</sup> and others regard the osmotic pressure as the force producing diffusion, but van Laar,<sup>5</sup>

<sup>1</sup> G. LILLIE, *Am. J. Physiol.*, **20** (1907), 133.

<sup>2</sup> Cf. J. LOEB, *J. Gen. Physiol.*, **1** (1918-19), 717; **2** (1919-20), 87; 173; 255; 273; 387.

<sup>3</sup> W. NERNST, "Theoretical Chemistry," London (1911).

<sup>4</sup> J. STIEGLITZ, "Qualitative Chemical Analysis," New York, Vol. 1 (1916), p. 9.

<sup>5</sup> J. VAN LAAR, "Vortrage über d. thermodynam. Potential urw. Braunschweig" (1906).



Wo. Ostwald,<sup>1</sup> and others regard the semipermeable membrane as necessary before true osmotic pressure may exist. In either case, however, and irrespective of the conception assumed as to the exact mechanism by which the membrane functions, the presence of such a membrane is necessary before such a pressure may be measured. Now if a column of water or mercury be placed upon the solution side of the system, the solvent will enter the solution only until the forces producing such movement are exactly counterbalanced by the hydrostatic pressure of the column, and a measure of this hydrostatic pressure is therefore a measure of the *osmotic pressure* of the system.

The existence of an osmotic pressure produced by protein solutions has been variously affirmed and denied. There is no difficulty experienced in obtaining a development of such a pressure by using an ordinary protein, but as the protein is subjected to exhaustive methods of purification, the osmotic pressure obtained constantly decreases, and Reid<sup>2</sup> has succeeded in obtaining a preparation of egg-albumin which exhibits no measurable osmotic pressure. On the other hand Reid found, after prolonged dialysis, osmotic pressures of haemoglobin which were perfectly constant, and indicated a molecular weight<sup>3</sup> of about 48,000. The reason for these variations in osmotic pressure has been asserted by Roaf,<sup>4</sup> and by Barcroft and Hill<sup>5</sup> to be due to a polymerization of the molecule which takes place upon the elimination of ionogenic impurities or combinations. This view is substantiated by the findings of Roaf that in distilled water haemoglobin shows a molecular weight (by osmotic pressure) of about 32,000 while in a solution of sodium carbonate, which would bring about further ionization, a molecular weight of only 16,000 is obtained.

The work of Lillie,<sup>6</sup> and especially the brilliant researches of Loeb,<sup>7</sup> have conclusively demonstrated that gelatin exhibits a perfectly definite osmotic pressure under any precisely specified conditions. With hydrochloric and sulphuric acids Loeb ob-

<sup>1</sup> WO. OSTWALD—FISCHER, "Handbook of Colloid Chemistry," Philadelphia (1915), 232.

<sup>2</sup> E. REID, *J. Physiol.*, **31** (1904), 438; **33** (1905), 12.

<sup>3</sup> See page 107 for a consideration of molecular weight determinations.

<sup>4</sup> ROAF, *Proc. Am. Phil. Soc., J. Physiol.*, **38** (1909), 1.

<sup>5</sup> BARCROFT and HILL, *J. Physiol.*, **39** (1910), 411.

<sup>6</sup> LILLIE, *Am. J. Physiol.*, **20** (1907), 127.

<sup>7</sup> J. LOEB, *J. Gen. Physiol.*, **1** (1918-19), **483**; **559**; **3** (1920-21), 691.



tained the following results upon a 1 per cent solution of originally isoelectric gelatin:

pH of solution	Osmotic pressure in mm. water		pH of solution	Osmotic pressure in mm. water	
	Gelatin chloride	Gelatin sulphate		Gelatin chloride	Gelatin sulphate
4.7	29	33	2.85	360	164
4.56	124	70	2.52	303	125
4.31	202	110	2.13	198	95
4.03	322	160	1.99	162	85
3.85	375	185	1.79	110	70
3.33	443	205	1.57	90	61
3.25	442	200			

These data illustrate two points of great interest. In the first place the osmotic pressure is found to vary enormously at different hydrogen-ion concentrations. In the above experiments the free acid had been washed out as far as could be determined, and the varying osmotic pressures developed may be attributed, according to Loeb, only to the varying amounts of gelatin chloride and gelatin sulphate produced. The maximum production of these salts is reached at a pH of about 3.4, which corresponds to the maximal development of osmotic pressure.

A second observation is that the maximum osmotic pressure obtained with sulphuric acid is only 205 mm. as contrasted with 443 mm. in the case of the hydrochloric acid. After making corrections for the pressure developed by isoelectric gelatin, the osmotic pressures become:

- Gelatin chloride..... 413 mm.
- Gelatin sulphate..... 180 mm.

In a similar way it was shown that on the alkaline side of the isoelectric point, gelatin, combined with monovalent cations, showed a maximal pressure of about 400 mm., while when combined with divalent cations it attained only 160 mm. By correcting as before, the osmotic pressure became:

- Li, Na, K, NH<sub>4</sub> gelatinate..... 370 mm.
- Ca, Ba gelatinate..... 130 mm.

If these differences in the maximal osmotic pressures are to be explained in accordance with the theory of van't Hoff and the laws of classical chemistry, it is necessary to assume a corresponding difference in the number of particles in solution. This question will receive more detailed attention in Chap. V.

Non-electrolytes appear to have no effect upon the osmotic pressure of gelatin. Inorganic salts act, however, in a very similar way to the acids and bases, but with this reservation: when the gelatin is in the form of an anion, as in sodium gelatin-ate, only the cation of the added salt is effective *e.g.*, the addition of calcium chloride would influence the osmotic pressure of the gelatin only by virtue of the calcium ion. A lowering would take place. Sodium sulphate would be ineffective. If, on the other hand, the gelatin were in the form of a cation, as in gelatin chloride, then only the anion of an added salt would influence the osmotic pressure, *e.g.*, sodium sulphate would lower this pressure, while calcium chloride would be without effect. The results of Hofmeister,<sup>1</sup> Pauli,<sup>2</sup> Lillie,<sup>3</sup> and others who have investigated this effect differ from those of Loeb both in order and degree. According to Lillie, the depressing effect of ions upon the osmotic pressure of gelatin follows the order: For cations: alkali metals < alkaline earths < heavy metals. For anions: CNS < I < Br < NO<sub>3</sub> < Cl < F < SO<sub>4</sub> < PO<sub>4</sub>.

Loeb ascribes the differences as due to the failure of the earlier investigators to measure the hydrogen ion concentration of their solutions. Thus when a buffer salt, like sodium acetate, is added to a gelatin chloride solution of pH 3.0 the gelatin solution is brought nearer to that of the isoelectric point, and this was interpreted by the earlier workers as the effect of the acetate anion. If the hydrogen ion concentration is taken into consideration it is found that sodium acetate acts like sodium chloride.<sup>4</sup> As Loeb's reports upon this subject are of comparatively recent date there has hardly been time as yet to ascertain to what degree his findings will replace the long accepted explanations of Hofmeister and Pauli. It seems certain, however, that Loeb has discovered a serious error in the earlier investigations, but

<sup>1</sup> HOFMEISTER, *Arch. expl. Path. Pharm.*, **24** (1888), 247.

<sup>2</sup> PAULI, *Beitr. physiol. path. Chem.*, **3** (1903), 224; *Fortsch. Naturwiss. Forschung*, **4** (1912), 237.

<sup>3</sup> LILLIE, *Am. J. Physiol.*, **20** (1907), 127.

<sup>4</sup> J. LOEB, *J. Gen. Physiol.*, **3** (1920-21), 407-8.

the theory which he advances to account for the new findings (which will be discussed in Chap. V) will doubtless meet with persistent opposition from the hands of many colloid chemists.

The development of a definite osmotic pressure by colloids is deducible from an altogether different line of argument. When a protein is allowed to stand with an acid or a base or under certain conditions a salt, a definite chemical reaction is found to occur,<sup>1</sup> which eventually reaches a definite equilibrium. If no osmotic pressure were developed in the system, the transformation of a given mass of the components would, according to Robertson, be dependent only upon the temperature, and not at all upon the concentration of the reacting components. The reaction would, therefore, proceed to completion, and no true equilibria could be obtained. But it has been shown many times that protein substances, especially in the form of their salts, do react with various other substances with the development of definite equilibria. This fact argues against the theory of Duclaux<sup>2</sup> that "colloids must be considered as having, in water, an absolute insolubility," and favors the laws of Avogadro and van't Hoff that, in the attainment of such equilibria, the colloid must be distributed throughout the solution in molecular dispersion. Due, however, to the tendency of colloids to polymerize when out of the influence of electrolytes, it seems probable that real *suspensions* may, under certain conditions, be obtained which will not reveal an osmotic pressure, and accordingly will not follow the law of Avogadro.

From the abundant literature upon the osmotic pressure of protein, every conceivable inconsistency of data has resulted. As examples of these the following striking illustrations may be taken:

Reid<sup>3</sup> found the osmotic pressure of ovalbumin, under the same conditions and prepared in the same way, to vary between 0.00 and 15.71 mm. of mercury.

Lillie<sup>4</sup> found the osmotic pressure of gelatin to increase, and of egg-albumin to decrease, on shaking.

<sup>1</sup> T. B. ROBERTSON, *Z. Chem. Ind. Kolloide*, **2** (1908), 49; "Physical Chemistry of the Proteins," New York (1918), 340.

<sup>2</sup> DUCLAUX, "Recherches sur les substances Colloïdals," Dissertation, Paris (1904), 100.

<sup>3</sup> REID, *J. Physiol.*, **31** (1904), 439; **33** (1905), 12.

<sup>4</sup> LILLIE, *Am. J. Physiol.*, **20** (1907), 127.

Biltz and von Vegesack<sup>1</sup> found the osmotic pressure of congealed to decrease, and of iron hydroxide sol to increase, with increasing concentration.

Bayliss<sup>2</sup> found the osmotic pressure of several proteins to increase directly with the absolute temperature. Moore and Roaf<sup>3</sup> found the osmotic pressure to increase much faster than the absolute temperature in gelatin sols, while Duclaux observed the increase to be slower than the absolute temperature in the case of iron hydroxide sol.

Lillie<sup>4</sup> affirms that all salts lower the osmotic pressure of gelatin.

One of the most encouraging developments of Loeb's theories lies in their ability to explain and adequately to account for the wide diversity and apparently chaotic confliction of the findings outlined above. When measurements are made in the presence of the excess of electrolyte, which has almost without exception been the case, the results obtainable are apparently without order or reason; but just as soon as the pure gelatin salt is once obtained, then, according to Loeb, the findings become well ordered, readily reproducible, and, above all, intelligible and explainable in conformity with the laws of classical chemistry.<sup>5</sup>

C. R. Smith<sup>6</sup> has taken exception to some of the conclusions reached by Loeb, although corroborating his experimental findings. He assumes that Loeb used an unpurified gelatin, but this seems contrary to the facts.<sup>7</sup> In his own experiments Smith employs an ash free product made by first washing out from the powdered material the divalent alkali salts using a 10 per cent sodium chloride solution containing about 5 c.c. of concentrated hydrochloric acid per liter, cooled to between 0 and 10° C., and then with 1 per cent salt solution without acid. The concentration of the salt solution is then diminished until finally aerated-distilled water is used. When the washings are free from chloride, cold 90 per cent alcohol is poured through the mass until it has

<sup>1</sup> BILTZ and VON VEGESACK, *Z. physik. Chem.*, **68** (1909), 357; **73** (1910), 481.

<sup>2</sup> BAYLISS, *Proc. Roy. Soc. (London)*, **81** (1909), 269.

<sup>3</sup> MOORE and ROAF, *Biochem. J.*, **2** (1906), 34; **3** (1907), 55.

<sup>4</sup> LILLIE, *loc. cit.*

<sup>5</sup> For a further discussion see Chap. V.

<sup>6</sup> C. R. SMITH, *J. Am. Chem. Soc.*, **43** (1921), 1350.

<sup>7</sup> Miss Field has confirmed Loeb's method for the preparation of a pure ash-free gelatin. *J. Am. Chem. Soc.*, **43** (1921), 667.



shrunken nearly to dryness, after which it is dried with an electric fan.

Smith concurs with Loeb in many points. He finds that isohydric solutions of acids or of bases of the same valency produce the same osmotic pressure, the value increasing on both sides of the isoelectric point, but being only about a third as great for bivalent as for monovalent electrolytes. The maxima occur in all cases, however, at the same pH. These values, according to Smith's data, which were calculated only, lie at about 3.2 and 10.3, for a concentration of 0.5 g. per 100 c.c., but the hydrogen ion concentration of maximum osmotic pressure was found to vary with the concentration of the gelatin. By direct measurement Loeb found the maximum osmotic pressure to occur at pH 3.4. Smith is led to believe that salt ions do not combine with gelatin, but rather increase the absorption of acids or alkalies. The decrease in osmotic pressure and swelling which they produce is explained as due to a decrease in the ionization of the acids or alkalies combined with the gelatin.

*The Determination of Osmotic Pressure.*—The technique of osmotic pressure determinations requires the utmost skill and painstaking care. In making such determinations upon molecular dispersoids and electrolytes it is, of course, necessary to employ a semipermeable membrane which will permit of the free passage of the solvent, but withhold completely the molecules or ions of the solute. Such membranes are found in the chemically precipitated films such as copper ferrocyanide, and the like. But when it is desired to obtain the osmotic pressure of a colloid it is very important that the membrane be permeable, not only to the pure solvent, but also to any molecular or ionogenic impurities that may be present. When such membranes have not been used it has been necessary to make corrections for the pressure developed by the impurity, and such a correction is usually, at best, only an approximate estimation.

Parchment paper is permeable to the smaller sized molecules and ions, and is especially easy of manipulation. The most careful workers have, however, usually employed collodion membranes. The preparation of these has been described on page 97.

For osmotic pressure determinations a 50 c.c. Erlenmeyer shaped sack is very satisfactory. The washed sack is filled with the colloid sol, and a two holed rubber stopper inserted in the neck and fastened securely with

several turns of a rubber band. In one of the holes of the stopper is placed a short glass tube, extending from the bottom of the stopper to about an inch above it. In the other is inserted a long glass tube, extending from the bottom of the stopper to a height of perhaps 24 inches. The large tube is left open. The colloid sol is introduced through the short tube until the liquid overflows; and this tube is then sealed with a short piece of rubber tubing, closed at one end. The sack is lowered into a large beaker containing the pure solvent, and the height to which the liquid rises in the long tube noted immediately, and at the end of a few hours, at which time it should reach its maximum. The difference in millimeters represents directly the osmotic pressure of the colloid sol in millimeters of water (or other solvent). Other more involved types of manometer may be used, and the pressure may be measured against mercury, but the procedure as outlined has been found very easy of manipulation, and capable of giving excellent and readily duplicable results.

**4. The Vapor Pressure.**—The vapor pressure of a liquid is due to an equilibrium which exists between the molecules of the liquid and those of a space above it which is saturated with the vapor of the liquid. The molecules of any given liquid at any given temperature tend to project themselves into the space above at a given rate. As soon as this space is *saturated* an equilibrium exists due to the fact that molecules from the vapor are entering the liquid at the same rate as those from the liquid are going into the vapor phase. Dissolved substances are found ordinarily to exert no vapor pressure. It must therefore follow that if a substance is dissolved in a liquid,—there being, in that case, a decrease in the number of *solvent* molecules in a unit area of surface, or volume of solution,—the number of molecules of solvent entering the vapor phase in unit period of time must be decreased. It must also follow that a smaller number of molecules in the vapor state will suffice to return to the solution, in unit period of time, the smaller number which are entering the vapor state. In other words, the vapor pressure of a liquid is lowered by the addition to it of dissolved, or otherwise dispersed, molecules, and van't Hoff has demonstrated that the lowering of the vapor pressure of a liquid is in direct proportion to the number of molecules or ions added.

It has long ago been shown, however, that colloids have very little effect on the vapor pressure of liquids. Some workers have obtained colloids which showed no change whatsoever,<sup>1</sup> while many others have reported various reductions. Lüdeking<sup>2</sup> was

<sup>1</sup> A. SMITS, *Z. physik. Chem.*, **45** (1903), 608.

<sup>2</sup> C. LÜDEKING, *Ann. Physik. Chem.*, **35** (1888), 552.

unable to obtain a definite lowering in vapor pressure with gelatin, but Guthrie<sup>1</sup> has reported positive results. Tammann<sup>2</sup> found a slight reduction in vapor pressure due to gelatin, but the concentration seemed to have no influence on the results.

The reason for the anomalous behavior of gelatin and other colloids in failing to reduce the vapor pressure of liquids in which they are dispersed lies undoubtedly in the size of the dispersed particles. It must here be recalled that liquids are regarded, according to the generally accepted theories, as consisting of particles (molecules, ions, or aggregates of these) which are widely separated from each other, and are moving freely about in the system. When dissolved molecules or ions are added, these, on mixing with the former, produce a dilution of the solvents molecules, in proportion to the *number* of molecules added. The size here seems to have practically no influence. But, according to Millikan,<sup>3</sup> a gram-molecule of a substance when molecularly dispersed contains about  $6 \times 10^{23}$  molecules. By calculating from a figure of this order, Perrin<sup>4</sup> obtained a "molecular weight" for gutta-percha of about  $3 \times 10^{10}$ .

The significance of these values is made evident by the provision of van't Hoff's theory which would require that thirty billion grams of gutta-percha,—since in that amount there are the same number of molecules as are contained in one gram molecule of any other substance,—must be dissolved in a liter of water in order that the same dilution of solvent molecules, and consequent lowering of the vapor pressure, might ensue as would be obtained by the addition of, for example, 60 g. of urea, or 342 g. of sugar. It becomes strikingly apparent that the addition of a colloid, in any amount which could reasonably be used, would have an almost negligible influence on the vapor pressure. Even if the molecular weight were placed as low as 2,433, which is the value assigned to gelatin by Hofmeister,<sup>5</sup> and is not properly comparable for this purpose, a gelatin sol would exert but a fortieth of the lowering that would be produced by an equal weight of urea.

<sup>1</sup> F. GUTHRIE, *Phil. Mag.* (5), **2** (1876), 219.

<sup>2</sup> G. TAMMANN, *Mem. Acad. St. Petersburg* (7) **35**.

<sup>3</sup> MILLIKAN, *Proc. Nat. Acad. Sci.*, **3** (1917), 314.

<sup>4</sup> J. PERRIN, *Compt. rend.*, **147** (1908), 475.

<sup>5</sup> See "Allen's Commercial Organic Analysis," 4th ed., vol. 8 (1912), 586.



**5. The Boiling Point and Freezing Point.**—As the temperature of a liquid rises, the number of molecules that will be ejected from it into the vapor space above will continually increase, on account of the added kinetic velocity of the molecules imparted by the increasing temperature, and, if the pressure above the liquid is permitted to remain constant, a temperature is eventually reached where the vapor pressure of the liquid is equal to the external pressure. This is called the *boiling point* of the liquid. It is obvious therefore that any condition which affects the vapor pressure of the liquid must, *a priori*, affect the boiling point. If the vapor pressure is lowered, as by the dissolving in it of a non-volatile substance, then the boiling point of the solution must be raised.

As the temperature is lowered to the *freezing point*, which is defined as the temperature at which, under a given pressure, the liquid and solid phase may exist together, the vapor pressure decreases and, when that point is reached, the vapor pressure of the liquid and that of the solid must be identical. But in the presence of a dissolved substance, which lowers the vapor pressure, an even lower temperature must be reached before the pressures exerted by the two phases are equal. In other words, a non-volatile dissolved substance lowers the freezing point of a liquid. Van't Hoff has shown, moreover, that just as the lowering of the vapor pressure is directly proportional to the number of dissolved molecules, so also are the elevation of the boiling point and the lowering of the freezing point directly proportional to this number.

In view of the above proportionality it is obvious that colloids can effect but little change in the boiling points or freezing points of liquids in which they are dispersed. Many attempts have been made however to determine the effect of various colloids upon these points, and the values obtained have often been used in calculating a "molecular weight." In illustration may be cited the work of Friedenthal,<sup>1</sup> who found a small but definite depression of the freezing point in solutions of soluble starch; Sabenejew and Alexandrow,<sup>2</sup> who found egg albumin to have a molecular weight of 14,270; Krafft and Sturtz,<sup>3</sup> who found the

<sup>1</sup> H. FRIEDENTHAL, *Zent. Physiol.*, **12** (1899), 849.

<sup>2</sup> A. SABENEJEW and N. ALEXANDROW, *J. Russ. Phys. Chem. Soc.*, **21** (1889), 397.

<sup>3</sup> F. KRAFFT and A. STURTZ, *Ber.*, **29** (1896), 1328.



molecular weight of sodium stearate to be about 1,500 at 16 per cent, and nearly infinity at 27 per cent concentration; Robertson and Burnett,<sup>1</sup> who found alkaline caseinates to show a molecular weight of 1,400 to 17,600; Lüdeking,<sup>2</sup> who found that even a 40 per cent solution of gelatin failed appreciably to affect the boiling point; and Krafft and Wiglow,<sup>3</sup> whose findings confirmed those of Lüdeking. One fact stands out conspicuously in the work of Robertson and Burnett, namely, that the depressions in the freezing points stand in direct proportion to the *concentration of combined base*. As the authors point out, this must mean that, if this relation held at all concentrations, then "at zero concentration of combined base, if casein were soluble under such conditions, the freezing point depression due to dissolved casein would be zero. In other words the possibility is indicated that base- and acid-free protein may exert an immeasurably small osmotic pressure." Robertson attributes this to a polymerization of the protein as the uncombined protein is set free.

**6. The Molecular Weight.**—There is one feature of the colloid conception which is almost invariably overlooked by investigators upon the subject, and which, in the opinion of the author, is of the utmost importance to a proper understanding of colloids, and especially of the proteins. The concept of colloids has been based almost entirely upon the size of the particles in suspension. For example, gold, which we know possesses a true molecular weight of 197.2 may readily be obtained in a colloid state of suspension: that is a large number of molecules are caused by some force to flock together into one "particle," and the size of these particles, which is, of course, determined by the absolute number of molecules composing them, is the criterion for the colloid state. It is well known that colloidal gold may easily be obtained in a number of different "degrees of dispersion," that is, a relatively small or a relatively large number of molecules may be aggregated together in each particle. Now it may be possible to obtain the relative weight of these particles by osmotic pressure, or vapor pressure methods, but no one would affirm that any value so obtained represented correctly the *molecular weight*. We know that arsenic trisulphide has a molecular weight of 246.1. A colloid particle of this substance may consist, for example, of

<sup>1</sup> T. B. ROBERTSON and T. BURNETT, *J. Biol. Chem.*, **6** (1909), 105.

<sup>2</sup> C. LÜDEKING, *Ann. chim. phys.*, **35** (1888), 552.

<sup>3</sup> F. KRAFFT and H. WIGLOW, *Ber.*, **28** (1895), 2566.

100 molecules. Then the particle weight would be 24,610, but under no condition would this be regarded as a *molecular weight*.

In the case of proteins quite a different condition obtains. There is no doubt but that many proteins contain molecules of such complexity that one individual may possess a true molecular weight of several thousand, and be of such size that a molecularly dispersed solution will lie in the field of the colloids. This point has been overlooked. Wo. Ostwald justly deprecates the use of osmotic pressure and vapor pressure methods in the calculation of so-called molecular weights of colloids, apparently basing his argument upon the theory that all colloidal particles are groups of polymerized molecules. In the great majority of cases his argument is doubtless correct, for just as gold and arsenic sulphide molecules may be caused to undergo an extensive polymerization, so also, and in reality much more easily, may protein molecules be caused to combine into large aggregates. The indications in the work of Robertson and others are that, when unionized, the proteins are highly polymerized aggregates of molecules, but when ionized may be obtained in a molecular degree of dispersion, although they are, even then, of colloid dimensions.

Bearing in mind these reservations molecular weight determinations may be of value in many ways, but it will be evident at once that such determinations, when made by different means, should not be expected to give results that are comparable with each other. Osmotic pressure, freezing point, and boiling point estimations, being dependent upon the number of particles in solution, will give values approaching the mass of the colloid complex, and this has been shown to vary greatly under different conditions. By determination of the combining capacity, an *equivalent weight* will be measured.

✓ *The Osmotic Pressure Method.*—Osmotic pressure is dependent for its existence upon the presence of molecules or otherwise dispersed particles in the solution, and has been found to be, in the case of molecular dispersoids, directly proportional to the number of molecules in the solution, and to the absolute temperature. In other words, the behavior of solutions is in conformity to the gas laws, and the osmotic pressure of a substance in solution is the same as the pressure which it would exert if it were in the form of a gas at the same concentration and temperature. These laws have no concern over the size of the par-

ticles, nor their degree of hydration. This being the case, it is at once apparent that the *molecular weight* or the average relative weight of the particles, may be calculated if the osmotic pressure is known. Thus

$$M = \left( \frac{22.4 \times 760}{273} \right) \frac{CT}{P},$$

where  $M$  is the molecular weight; 22.4 the osmotic pressure of one gram-molecule of any molecularly dispersed substance at 0 degrees; 760, the pressure in millimeters of mercury of the atmosphere at sea-level; 273, the absolute temperature of zero degrees Centigrade;  $C$ , the concentration of the solute in per cent;  $T$  the absolute temperature of the observation; and  $P$  the osmotic pressure observed.

This formula has frequently been used in an estimation of the so-called molecular weight of proteins and other colloids. The justifiability of such an application has been seriously questioned by Wo. Ostwald,<sup>1</sup> von Smoluchowski,<sup>2</sup> and others. Ostwald maintains that, in the case of colloids, the degree of dispersion and the degree of hydration of the dispersed phase must be considered. M. von Smoluchowski has developed a formula based upon the molecular-kinetic theory which concludes that "the osmotic pressures of two equally concentrated but differently dispersed phases are inversely proportional to the cubes of the radii of their particles." The argument of both of these investigators is based largely upon the observed and measured Brownian movement, which is found to be greater in the more highly dispersed systems. It would surely seem to be an *a priori* necessity, and based upon the most fundamental principles, that the more rapidly the particles in a solution or suspension are moving, the greater must be the osmotic pressure resulting from such movement.

Experimental evidence of the soundness of this reasoning is not lacking. Bayliss<sup>3</sup> has found in experiments upon congo-red that those factors which produce a decrease in degree of dispersion, as shaking, aging, addition of electrolytes, etc., decrease the osmotic pressure, while other factors which increase the degree of dispersion, also increase the osmotic pressure. Duc-

<sup>1</sup> Wo. OSWALD, *lib. cit.*

<sup>2</sup> M. VON SMOLUCHOWSKI, Boltzmann-Festschrift, Leipzig (1904), 626.

<sup>3</sup> W. BAYLISS, *Proc. Roy. Soc. (London)*, **81** (1909), 269; *Kolloid-Z.*, **6** (1910), 23.



laux<sup>1</sup> observed that the osmotic pressure of the highly dispersed red gold hydrosol was considerably greater than that of the more coarsely dispersed blue variety. Ostwald<sup>2</sup> found that the osmotic pressure and the swelling of gelatin disks paralleled each other under the influence of acids and alkalis, even to details. These observations, when taken in connection with the great disparity between measurements made by different investigators, lead, if not to the entire rejection of the osmotic pressure method for so-called molecular weight determinations of colloids, at least to a reserved use for such expressions. They are of undisputable use in comparative studies, but a dogmatic acceptance of the absolute values reported seems, at the present time, to be dangerous and unjustified. For this reason it appears more expedient to use the results of osmotic pressure determinations *per se*, rather than to make use of the calculated hypothetical molecular weight.

C. R. Smith<sup>3</sup> has observed that the osmotic pressure of a gelatin solution in water is proportional to the concentration, and, assuming the applicability of the gas laws, finds a molecular weight for the gelatin of 96,000.

Loeb<sup>4</sup> found the osmotic pressure due to the gelatin particles of a 1 per cent solution of gelatin phosphate of pH 3.60 to be about 100 mm. of water. Since the osmotic pressure of 1 gram molecule is about 250,000 mm. of water, and since 1 liter of a 1 per cent solution of gelatin contains 10 g. of gelatin, Loeb deduces that the molecular weight of gelatin should be expected to be in the neighborhood of 25,000.

*The Boiling Point Method.*—By employing the boiling point method as previously described on a gelatin that had been rendered nearly ash-free (0.07 per cent ash) by prolonged dialysis, Paal<sup>5</sup> obtained values for the molecular weight of gelatin ranging from 878 to 960.

*The Combining Capacity Method.*—In a study of the equilibrium between hydrochloric acid and gelatin, Procter<sup>6</sup> found that the gelatin entered into chemical combination with the chloride

<sup>1</sup> DUCLAUX, *Compt. rend.*, **148** (1909), 295.

<sup>2</sup> WO. OSTWALD, *lib. cit.*

<sup>3</sup> C. R. SMITH, *J. Am. Chem. Soc.*, **43** (1921), 1350.

<sup>4</sup> J. LOEB, *J. Gen. Physiol.*, **3** (1921), 704.

<sup>5</sup> C. PAAL, *Ber.*, **25** (1892), 1202.

<sup>6</sup> H. R. PROCTER, *J. Chem. Soc.*, **105** (1914), 313. See also page 128.



ion, and that this combination appeared to be a reversible reaction following the Mass Law, and conforming to the Ostwald hydrolysis formula for a diacid base. That is,

$$y = \frac{x}{x + k_1} + \frac{x}{x + k_2} \times \frac{100}{M},$$

where  $y$  is the proportion of unhydrolyzed salt to the total base present;  $x$ , the molecular concentration or normality of the equilibrium-acid;  $M$ , the molecular weight of the gelatin;  $k_1$  the hydrolysis constant of the primary dissociation; and  $k_2$  the hydrolysis constant of the secondary dissociation. As there are three variables,  $k_1$ ,  $k_2$ , and  $M$ , Procter used a method of approximation, arbitrarily fixing  $M$ , calculating  $k_1$  and  $k_2$ , and applying to the formula above. Only when the value of  $M$  is very nearly accurate will the calculated and experimental values of  $y$  coincide throughout. The value of 839 for the molecular weight of the gelatin was thus derived which appeared to conform satisfactorily to the provisions of the formula. Using this value Procter calculated the "rational" formula of gelatin to be

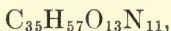

which gave a percentage composition corresponding very well with results obtained analytically:

	Theoretical	Experimental
C.....	50.06	50.1
H.....	6.79	6.6
O.....	24.79	25.0
N.....	18.36	18.3

It will be observed that the value of 839 for the molecular weight of gelatin corresponds very well with the values 878 to 960 obtained by Paal<sup>1</sup> using the boiling point method. It would seem probable from this that the sol of Paal was molecularly dispersed, and that, in that instance at least, the colloid particle was not an aggregate of molecules, as is usually the case in colloid sols, but consisted of an individual gelatin molecule.

Working on the assumption that gelatin is a monoacid rather than a diacid base in its reactions with dilute hydrochloric acid, Wilson,<sup>2</sup> by similar methods to those employed by Procter,

<sup>1</sup> C. PAAL, *loc. cit.*

<sup>2</sup> J. A. WILSON, *J. Am. Leather Chem. Assn.*, **12** (1917), 115.

found gelatin to have a molecular weight (or an equivalent weight multiple) of 768, and gave it the slightly altered formula

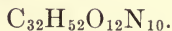

In support of this view Wilson observed that in the tanning of leather by the sesquioxid of chromium, from 3.2 to 3.5 per cent of the latter is held in combination by the hide. Considering the hide as collagen with the molecular weight of 750 (gelatin-water), the smallest amount of the chromic oxide required to convert 100 g. of collagen into the chromium salt would be:

$$\frac{152 \times 100}{6 \times 750} = 3.38 \text{ grams,}$$

which agrees well with the observed amount found to be necessary.

The value 768 also seems highly probable from the conformity of the experimental and the mathematical curves obtained by plotting the c.c. of solution absorbed by one millimol of gelatin against the concentration of hydrogen ion in the external solution, when the molecular weight of gelatin is assumed to be 768. These curves are shown on pages 181-2.

Thomas<sup>1</sup> has obtained an octachrome collagen, and by applying the value of 750 as the *molecular* weight of collagen, has obtained the value of 93 as the *combining* weight of collagen.

*Calculation from Amino Acids.*—If the attempt is made to calculate the molecular weight of gelatin from the amino-acid content, comparatively high results are obtained. The most reliable amino-acid determinations that have been made are those of Dakin.<sup>2</sup> If the percentages of nitrogen represented by the several amino-acids are to be altered so as to represent nitrogen atoms it becomes necessary to multiply each percentage figure by some factor.

The histidine molecule contains three atoms of nitrogen, the arginine four and the lysine two. All others one each. The histidine nitrogen is present in only very small amounts (0.9 per cent), but if only one molecule be present in the gelatin complex, it will contain three nitrogen atoms. In order to raise the histidine value to 3, it is necessary to multiply the percentage figure by 3.33. If this factor be used throughout, the results shown below in Col. 3 are obtained. By eliminating the frac-

<sup>1</sup> A. W. THOMAS, paper presented at New York Meeting of Am. Chem. Soc., Sept. 6 to 10, 1921.

<sup>2</sup> H. D. DAKIN, *J. Biol. Chem.*, **44** (1920), 499.

tions and dividing by the number of nitrogen atoms per molecule, the number of molecules of each amino-acid present are found (Col. 5), and by multiplying these by the number of nitrogen atoms in each molecule the revised number of nitrogen atoms is obtained. This number is found to be 305, which multiplied by the atomic weight of nitrogen and divided by the percentage of nitrogen in gelatin gives the molecular weight of the gelatin:

Amino acid	Per cent of total nitrogen	× 3.33	N atoms in molecule	Number of molecules	Product of last two columns
Glycine.....	25.5	85.0	1	85	85
Alanine.....	8.7	29.0	1	29	29
Leucine.....	7.1	23.6	1	24	24
Serine.....	0.4	1.3	1	1	1
Phenylalanine.....	1.4	4.7	1	5	5
Proline.....	9.5	31.6	1	32	32
Hydroxyproline....	14.1	47.0	1	47	47
Aspartic acid.....	3.4	11.3	1	11	11
Glutamic acid.....	5.8	19.3	1	19	19
Histidine.....	0.9	3.0	3	1	3
Arginine.....	8.2	27.3	4	7	28
Lysine.....	5.9	19.7	2	10	20
Ammonia.....	0.4	1.3	1	1	1
Total.....	91.3	304.1	...	..	305

$$\frac{305 \times 14 \times 100}{18} = 23,700.$$

The value 23,700 is obtained as the calculated molecular weight of gelatin, but too great significance should not be placed upon a value derived in this manner.

The values obtained for the molecular weight of gelatin by the various methods are brought together below:

Schutzenberger and Bourgeois <sup>1</sup> (1876).....	1,836
Paal <sup>2</sup> (1892).....	878 to 960
Berrar <sup>3</sup> (1912).....	823

<sup>1</sup> SCHUTZENBERGER and BOURGEOIS, *Jahresber. Thier. chem.* (1876), 30.

<sup>2</sup> PAAL, *loc. cit.*

<sup>3</sup> BERRAR, *Biochem. Z.*, **47** (1912), 189.

Procter <sup>4</sup> (1914).....	839
Biltz, Bugge, and Mehler <sup>5</sup> (1916).....	5,500 to 31,000
Wilson <sup>6</sup> (1917).....	768
Lloyd <sup>7</sup> (1920).....	10,300
Smith <sup>8</sup> (1921).....	96,000
By calculation from Dakin <sup>9</sup> (1920).....	23,700
Loeb <sup>10</sup> (1921).....	25,000

<sup>4</sup> PROCTER, *loc. cit.*

<sup>5</sup> BILTZ, BUGGE, and MEHLER, *Z. physik. Chem.*, **91** (1916), 705.

<sup>6</sup> WILSON, *loc. cit.*

<sup>7</sup> LLOYD, *Biochem. J.*, **14** (1920), 166.

<sup>8</sup> SMITH, *loc. cit.*

<sup>9</sup> DAKIN, *loc. cit.*

<sup>10</sup> LOEB, *loc. cit.*

**7. The Surface Tension.**—All liquids appear to possess different properties at the surface than at other interior points. For example, if a capillary tube of glass is placed upright in water, the water is observed to rise in the tube to a point higher than the surface of the external liquid, and the surface of this water in the tube is curved downwards, *i.e.*, the water rises higher adjacent to the glass than in the centre of the tube. If a tube be made of some material which is not wetted by the water, or if a glass tube be placed in mercury, which does not wet glass, the reverse conditions are found to obtain. The surface of the liquid in the tube is below the surface outside, and the meniscus is convex. Again, if a needle be placed carefully upon water it may be caused to float. These phenomena are the result of the existence, at the surface of liquids, of a film, and of the resistance of this film to being broken. The strength of this film varies greatly in different liquids, and a measure of its resistance to breaking is known as the *surface tension* of the liquid.

Nearly all inorganic salts in solution raise the surface tension of the solvent, while colloids of the suspensoid class are, as a rule, without effect. Emulsoid colloids, on the other hand, usually lower the surface tension. Small amounts of soaps are especially effective; egg albumin is less so. Gelatin lowers the surface tension of water, but to a lesser degree than the others named. Table 29, taken from Quincke,<sup>1</sup> illustrates this effect.

The surface tension of liquids decreases with rise in temperature, but, if a substance which lowers surface tension is dispersed in the liquid, the lowering will be proportionately greater than

<sup>1</sup> G. QUINCKE, *Ann. Physik.*, **10** (1903), 507. Cited after Ostwald.



TABLE 29.—SURFACE TENSION OF COLLOID SOLS 20° C.

Substance	Specific gravity	Surface tension against air
Water.....	1.0000	8.253
Egg albumin.....	1.0384	5.141
Venetian soap ( $\frac{1}{400}$ per cent).....	0.9992	2.672
Isinglass.....	1.0000	6.790
Gelatin <sup>1</sup> .....	1.0000	7.272

<sup>1</sup> Bancroft questions the accuracy of the specific gravity data indicated for gelatin sols.

in the pure solvent. This is shown by the following table from Zlobicki:<sup>1</sup>

TABLE 30.—CHANGES IN SURFACE TENSION WITH TEMPERATURE

Temperature	Water	2 per cent gelatin sol
0.0	7.69	6.62
11.3	7.52	6.21
17.0	7.43	5.98
24.5	7.32	5.70

Of especial importance in a study of gelatin is the theorem of Willard Gibbs,<sup>2</sup> which states that substances which lower the surface tension of a liquid tend to become more highly concentrated in the surface layer than at other parts of the solution. This theorem applies, however, according to Bancroft (personal communication) only to true solutions. Ramsden,<sup>3</sup> who has studied this phenomenon with proteins, concludes that the formation of membrane-like films which appear upon the surface of some proteins, such as milk and gelatin, on heating, is attributable to this effect. It seems certain that, in the case of gelatin at least, another important factor in the film formation is a dehydration occurring at the surface. The combined effect of a

<sup>1</sup> L. ZLOBICKI, *Bull. Acad. Sc. Cracovie* (1906) 488. Cited after Ostwald.

<sup>2</sup> W. GIBBS, *Trans. Conn. Acad. Arts. Sci.*, **3** (1874-1878).

<sup>3</sup> N. RAMSDEN, *Arch. Anat. Physiol.* (1894), 517; *Z. physik. Chem.*, **47** (1904), 336.

surface concentration, a high temperature, and a dehydration, are entirely adequate to account for the heavy films formed over a heated solution of gelatin or glue.

That the formation of films is not confined to the surface exposed to the air only, but may be produced also at a liquid interface, is shown by the experiments of Winkelblech,<sup>1</sup> which have been extended and modified by a number of later investigators. If a little gelatin sol is shaken up with benzine, chloroform, or other hydrocarbon, a large number of droplets are produced at the liquid interface between the two solvents. These droplets are unusually stable. Long standing, long washing, treating with N/10 alkali, or shaking with more hydrocarbon fail to bring about a coalescence. But if alcohol is added it enters the droplets, probably by osmosis, causing them to swell and burst, and the broken membranes may be seen floating in the otherwise clear solution.<sup>2</sup> Much significance is placed upon these experiments by Bancroft,<sup>3</sup> who uses them as the basis of a theory of emulsions which postulates that the efficacy of an emulsifying agent is attributable to the formation of similar membranes around the dispersed phase of the emulsion.<sup>4</sup>

**8. The Optical Rotation.**—When polarized light is allowed to pass through the solution of an organic substance which contains an asymmetric carbon atom, the ray of light is rotated in one direction or the other, depending upon the structure of the asymmetric group, and the extent of such rotation, is known as the *optical rotation* of the solution. The *specific rotation* is designated by the symbol  $[\alpha]_D$ , and refers to the rotation produced by a solution of unit density in a layer of unit length. That is, the observed rotation in degrees is divided by the length of the tube in which the solution is contained, and by the density of the solution at the temperature of observation.

Prior to 1910 there had been very little work reported upon the optical rotation of gelatin. De Bary,<sup>5</sup> Krüger,<sup>6</sup> and Framm<sup>7</sup>

<sup>1</sup> WINKELBLECH, *Z. angew. Chem.*, **19** (1906), 1953.

<sup>2</sup> T. B. ROBERTSON, *J. Biol. Chem.*, **4** (1908), 1.

<sup>3</sup> W. D. BANCROFT, *J. Phys. Chem.*, **19** (1915), 297.

<sup>4</sup> See page 214.

<sup>5</sup> DE BARY, Hoppe-Seyler's "Medizinisch-Chemische Untersuchungen," **1** (1866), 71.

<sup>6</sup> KRÜGER, Mayl's "Jahresberichte über die Fortschritte der Tierchemie," (1889), 29.

<sup>7</sup> FRAMM, *Arch. ges. Physiol.*, **68** (1897), 144.

had shown that the specific rotary power of gelatin changes with the temperature, and that prolonged heating at 100° gives a product, known as  $\beta$  gelatin, which produces a rotation lower than that of ordinary gelatin. Trunkel,<sup>1</sup> in 1910 made a valuable contribution to the subject by showing (1) that the specific rotation of a gelatin sol is practically constant between 30 and 80°C.; (2) that the rotation increases considerably to the left as the temperature is lowered to 10°; and (3) that the rotation may be brought back to its original value by again raising the temperature. C. R. Smith<sup>2</sup> has recently made a more exhaustive study of the subject, and especial attention will be given to the extraordinarily suggestive findings of this investigator.

By using a high grade ossein gelatin Smith found that above 33°C. a perfectly constant rotation was attained in a short period of time. At lower temperatures several hours must be allowed for the rotation to become constant. At and above 35° the specific rotary power is practically constant for all gelatins used, and at all concentrations. As the solution becomes cooler than 35° the specific rotation rapidly drops until, at 15° and below, it has again become constant. At all intermediate temperatures the specific rotation varies between these two values as the temperature. From a large number of averages,  $[\alpha]_D$  at 35° and above, calculated on a moisture- and ash-free basis, is taken as  $-141^\circ$ ; and at 15° and below  $[\alpha]_D = -313^\circ$ .

This peculiar behavior of the gelatin leads to the belief that there are two distinct forms of the substance: one, which Smith calls sol form A, is stable at 35° and above; the other, gel form B, is stable at 15° and below. At any other temperature there will exist an equilibrium of the two forms, or

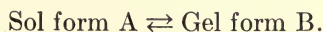

In support of the postulation of the existence of an equilibrium of two distinct types of gelatin between the temperatures of 15 and 35°, the velocity of mutarotation, *i.e.*, the velocity of the change in rotation, was studied, and found to conform to the usual equations for a bimolecular reaction in which the two reacting components are present in equivalent proportions. By applying the equation  $dx/dt = k(a - x)^2$ ,—which, when inte-

<sup>1</sup> TRUNKEL, *Biochem. Z.*, **26** (1910), 493.

<sup>2</sup> C. R. SMITH, *J. Am. Chem. Soc.*, **41** (1919), 135; *J. Ind. Eng. Chem.*, **12** (1920), 878.

grated, becomes  $k = 1/t \cdot x/a(a - x)$ , where  $a$  represents the active mass of each component;  $x$ , the quantity transformed in time  $t$ ; and  $k$ , a constant,—Smith obtained a fairly uniform value for  $k$  at any given temperature. Further, by applying the mathematical expression for the equilibrium,  $(a - x)^2/x = K$ ,—where  $a$  is the difference, about 1.20, between the rotations produced by one gram of gelatin at 35° and at 17°;  $x$  is the difference in rotation between that at 35° and at a specified temperature; and  $K$  is a constant,—a reasonably constant value for  $K$  was obtained at any specified temperature.

Of especial interest is the relation which is shown between the gelling power and the amount of gel form B present. It appears that in the entire absence of the gel form, the gelatin may not be caused to gel at any concentration. If an amount of the gel form from 0.55 to 1.00 per cent is present, then gelation will take place. It is practically immaterial whether there be any sol form present. At or below 15°, where the gelatin is *all* in the gel state, then 0.55 g. of gelatin made up to 100 c.c. with water will produce a jelly. If the temperature is, say 30°, it will require at least 10.0 g. of gelatin in 100 c.c. in order that there may be 0.55 to 1.00 g. of the gel form present, *i.e.*, in order that gelation may occur. If the temperature is 35°, then all of the gelatin will be in the sol state, and gelation will not occur at any concentration. Upon the basis of these experiments a new conception of *melting point* is established, namely the maximum temperature at which there will be present in the solution 0.55–1.00 g. of the gel form B, which is the critical amount necessary for gelation. This should also be exactly identical with the *setting point*.

Any increase in the proportion of gel form B is found to be indicated simultaneously by an increase in viscosity and (after the substance has become a jelly) jelly consistency, and also by an increase in the levorotation of the material. This relationship has led to an adaptation of the polariscopic measurement of optical rotation to control processes in the manufacture of gelatin and glue. This will be considered in Chap. VIII.

It should be pointed out that the salts which proteins form with acids or bases often differ very considerably in their rotatory power from the uncombined protein. This has been found to be true in the case of a large number of proteins but, so far as the author is aware, there has been no study made upon the exact



relations between the pH value of gelatin and the rotation which it exhibits. Until this has been done the use of the specific rotatory power of gelatins or glues as a property characteristic only of the equilibrium Sol Form A  $\rightleftharpoons$  Gel Form B, should be regarded as suggestive, but hardly as conclusive in any instance.

**9. The Index of Refraction.**—Very little work of a careful nature has been reported upon the refractive index of gelatin. By far the most exhaustive treatment of the subject was made by Walpole<sup>1</sup> in 1913. By employing a Zeiss immersion refractometer he investigated the refractive index of gelatin in both the sol and gel condition, and in solution in pure water, acids, bases, and salts. Except for a few minor variations he found that at any given temperature the refractive index of gelatin is a linear function of the concentration; that no variation is noted in the refractive index on passing from the sol to the gel state; that the refractive index is the same in solutions of acids, bases, or salts as it is in pure water; and that the position of the salt or ion in the so-called lyotropic series has no influence upon the refractive index. He reports the most probable value of the refractive index of dry ash-free gelatin in 1 per cent solution in pure water at 17.5°C. to be 0.001824.

In their essential characteristics these conclusions are quite identical with those obtained by Robertson<sup>2</sup> upon casein, gliadin, serum globulin, and other proteins, and by Reiss<sup>3</sup> upon serum albumin. In all of these cases the refractive indices are very accurately proportional to the concentration, and are independent of the nature of the acid, base, or salt with which they are combined. Robertson accordingly writes the equation for the refractive index of any solution of the proteins investigated by him:

$$n - n_1 = a \times c,$$

where  $n$  is the refractive index of the solution;  $n_1$ , that of the solvent;  $c$ , the percentage of protein in the solution; and  $a$ , the specific refractivity of the protein, which represents the change in the refractive index of the solvent which is brought about by dissolving one gram of the protein in 100 c.c. The equation may be more advantageously written:

<sup>1</sup> G. WALPOLE, *Kolloid-Z.*, **13** (1913), 241.

<sup>2</sup> T. B. ROBERTSON, "The Physical Chemistry of the Proteins," 361.

<sup>3</sup> E. REISS, *Arch. expl. Path. Pharm.*, **51** (1903), 18.

$$a = \frac{n - n_1}{c}$$

That the equation applies equally well to gelatin is evident from the following table taken from Walpole:

TABLE 31.—THE REFRACTIVE INDEX OF GELATIN SOLUTIONS

<i>c</i>	<i>n</i>	<i>n</i> - <i>n</i> <sub>1</sub>	<i>a</i>
0 (H <sub>2</sub> O)	1.33097 (= <i>n</i> <sub>1</sub> )		
0.25	1.33142	0.00045	0.00180
0.50	1.33183	0.00086	0.00172
0.75	1.33251	0.00154	0.00205
1.00	1.33274	0.00177	0.00177
1.25	1.33307	0.00210	0.00168
1.50	1.33373	0.00276	0.00184
1.75	1.33410	0.00313	0.00179
2.00	1.33456	0.00359	0.00179

The explanation of the independence of the index of refraction on the nature of the solvent probably lies in the fact that refractivity is a function of the volume occupied by the particle. The molecular volume is nearly equal to the sum of the atomic volumes, and since the ionic volume of the protein ion is many hundred times the atomic volume of any of the inorganic ions, very little change in the molecular volume could result from any interchange of inorganic atoms in the protein molecule. Some change in volume undoubtedly takes place on substituting, say, a potassium or a chloride ion for one of hydrogen, but this is insufficient to make itself felt by the known methods of measurement of refractive index. Fischer would explain the constancy of the index of refraction of gelatin-water systems as dependent upon the fact that, in medium concentrations of the system, hydrated gelatin has about the same index as gelatin solution.

The author has been unable to observe a definite alteration in the refractive index of gelatin sols upon partial hydrolysis to proteoses, which shows that a halving, or even a quartering of the original gelatin molecule (which has probably taken place during the hydrolysis) does not sufficiently alter the molecular volume to find expression in refractive index measurements.

This agrees with Robertson's findings with casein, and the latter investigator has suggested a method<sup>1</sup> for the determination of the comparative activities of trypsin solutions, based upon the constancy of the refractive index upon hydrolysis of the casein.

The influence of temperature upon the refractive indices of proteins is very slight. If allowance is made for the alteration in the refractive index of the solvent with varying temperature, the variation in the protein alone will be nearly inappreciable between 20 and 40°C.

On account of the simple relation obtaining between the refractive index of proteins and their concentration, and the constancy of this value irrespective of the solvent or the hydrogen ion concentration employed, the determination has been applied to a number of proteins as a basis for estimating the concentration of the protein in the solution. This has been especially successful with blood-serum, but a number of other proteins, as casein, globulin, albumin, etc., have also been examined in this way.

**10. The Gold Number.**—Colloids of the "suspensoid" class, such as the sols of arsenic sulphide, ferric hydroxide, etc., are very easily precipitated from the colloidal condition by the addition of electrolytes. The addition of an emulsoid colloid to the suspensoid is, however, even in very minute quantities, capable of greatly lessening or even quite inhibiting precipitation upon adding the electrolyte.<sup>2</sup> It was shown by Zsigmondy<sup>3</sup> that different emulsoids exhibited different degrees of effectiveness in this regard, and he suggested a scheme, based upon these differences, of determining the relative *colloidality* of emulsoids; for distinguishing between various commercial preparations; and for differentiating between proteins which cannot readily be distinguished by other tests.

Zsigmondy proposed that the number of milligrams of a colloidal substance which just fail to prevent 10 c.c. of a bright red gold sol, prepared by a standard method, from changing into violet upon the addition of 1 c.c. of a 10 per cent solution of sodium chloride, be known as the *gold number* of that colloid. In order that comparable results may always be obtained, it is necessary always to carry out the procedure in the same way.

<sup>1</sup> T. B. ROBERTSON, *J. Biol. Chem.*, **12** (1912), 23.

<sup>2</sup> Bancroft (personal communication) points out that the addition of even smaller quantities of emulsoid colloid may precipitate the suspensoid.

<sup>3</sup> ZSIGMONDY, *Z. anal. Chem.*, **40** (1901), 697; ZSIGMONDY and SCHULZ, *Beitr. physiol. path. Chem.*, **3** (1903), 137.

The gold sol may be prepared as follows:<sup>1</sup> 120 c.c. of water, that has been distilled through a silver condensing tube into a 500 c.c. Jena glass beaker, are heated, and 2.5 c.c. of a 0.6 per cent solution of hydrogen gold chloride and 3 to 3.5 c.c. of 0.18 N potassium carbonate solution of the highest possible purity are added. After boiling, and while still hot, 3 to 5 c.c. of dilute formaldehyde, made by adding 0.3 c.c. of formalin to 100 c.c. of water, are added. A bright red color is produced in a short time. To determine the "gold number" small quantities of the colloid are introduced into a series of 50 c.c. Jena beakers. A 0.2 c.c. pipette, graduated to thousands of a cubic centimeter, is used, and the quantities delivered should, for the first trial, be 0.005, 0.01, 0.02, 0.05, 0.1 and 0.5 c.c. Five cubic centimeters of the gold sol are then introduced into the beakers, mixed with a Jena glass rod, and allowed to stand 3 to 5 minutes. Then 0.5 c.c. of a solution of sodium chloride, made by adding 100 g. of pure sodium chloride to 900 c.c. of water, are introduced and stirred in. The concentration of emulsoid in the gold sol that just retains the red color, and in the next one which shows a change to a blue or violet, is noted. These values, multiplied by 2, define the gold number for that colloid.

Hatschek<sup>2</sup> suggests that it would be better to express the "gold number" as the percentage concentration of emulsoid in the gold sol which just prevents the color change when 1 c.c. of normal sodium chloride is added to 10 c.c. of gold sol. Thus, if the tube with 0.2 c.c. of emulsoid remains unaltered while that with 0.1 c.c. has turned blue, the emulsoid concentrations are, if 10 c.c. of gold sol and 1 c.c. of N NaCl solution are used:

$$0.2/10.2 = 0.0196 \times \text{original emulsoid concentration};$$

$$0.1/10.1 = 0.0099 \times \text{original emulsoid concentration}.$$

The "gold number" in percentage lies between these values.

It is evident that the smaller the value of the "gold number," the more effective is the protective action of the emulsoid. It is especially interesting that gelatin possesses the lowest "gold number" of any colloid, which shows that its protective action is very great. The following table gives the "gold number" of a number of colloids.

Menz<sup>3</sup> in 1909 showed that the protective action of gelatin increased as the concentration of the same was decreased. Elliott and Sheppard<sup>4</sup> have corroborated the findings of Menz, and have by ultramicroscopic studies been able to confirm his

<sup>1</sup> S. B. SCHRYVER, "Allen's Commercial Organic Analysis," vol. 8, p. 78.

<sup>2</sup> E. HATSCHKE, "Laboratory Manual of Colloid Chemistry," Philadelphia (1920), 97.

<sup>3</sup> W. MENZ, *Z. physik. Chem.*, **68** (1909), 129.

<sup>4</sup> F. A. ELLIOTT and S. E. SHEPPARD, *J. Ind. Eng. Chem.*, **13** (1921), 699.



theory that protective action is dependent solely upon the concentration of *amicrons* present in the solution. A decrease in total concentration of gelatin was shown to result in an actual increase in the concentration of the smaller sized particles. An aging of the solution results in flocculation, hence a decrease in amicon concentration, and a decrease in protective action.

TABLE 32.—THE GOLD NUMBER OF PROTEINS AND OTHER SUBSTANCES

Substance	Gold number (Zsigmondy)
Gelatin.....	0.005–0.1
Russian glue.....	0.005–0.01
Isinglass.....	0.01 –0.02
Caseinogen.....	0.01
Egg globulin.....	0.02 –0.05
Amorphous egg-albumin.....	0.03 –0.06
Ovomucoid.....	0.04 –0.08
Glycoprotein.....	0.05 –0.1
Fresh egg-white.....	0.08 –0.15
Crystallized egg-albumin.....	2.0 –8.0
Dextrin.....	10 –20
Potato starch.....	25 –
Deutero-albumose.....	∞

**11. The Tyndall Effect and Ultramicroscopy.**—Nearly all colloidal solutions, including those of the proteins, show a decided opalescence. Even if the solutions appear to be perfectly clear to ordinary observation, yet if they are so placed that they may be observed at right angles to a beam of light which passes through the solution, a cone of light, known as the *Tyndall effect*, is usually seen. This is due to a scattering of the light by the particles in the solution, just as dust particles in the air, which are ordinarily invisible, are made evident by a beam of light entering an otherwise dark room. The smallest particles which are capable of dispersing light must have a diameter, according to de Bruyn,<sup>1</sup> of from 5 to 10 $\mu\mu$ . Robertson<sup>2</sup> has endeavored to show by an uncertain calculation that the molecule of casein is about 2.4 $\mu\mu$ , or only about half the diameter of the smallest particle that will scatter transmitted light. He

<sup>1</sup> L. DE BRUYN, *Rec. Trav. chim.*, **19** (1900), 236; 251.

<sup>2</sup> T. B. ROBERTSON, "Physical Chemistry of the Proteins" (1918), 343.

suggests that the opalescence of protein solutions may not, therefore, be ascribed to the protein molecules themselves, but may perhaps be "attributable to the peculiar characteristics of ionic protein," as for example the property of the protein to become hydrated, or possibly the net-structure, which he assumes all proteins to possess. That ionic protein is not necessary is shown however from the fact that the most beautiful opalescent colloid systems can be made out of organic solvents with nitrocellulose or soaps.

Konovalov<sup>1</sup> offers another explanation. He points out that dust particles may act as nuclei, in solutions of low osmotic pressures, to which the dissolved protein will adhere, and an observed opalescence may be produced by a comparatively small number of such aggregates.

It is probably true that one or another of the above explanations may function in special cases where a protein is obtained in a true molecular state of dispersion, but in the great majority of protein solutions which exhibit opalescence it is probable that a greater or lesser degree of polymerization has taken place, and it seems highly probably that the aggregates so obtained may be of sufficient size to act themselves as dispersers of transmitted light.

Siedentopf and Zsigmondy<sup>2</sup> have applied the microscope in an ingenious manner to solutions which exhibit the Tyndall effect. A powerful beam of light is caused to traverse in a horizontal direction a thin portion of the solution and a high power microscope focused orthogonally upon the points of light diffracted. By this simple process they have been able to study particles in solution that had hitherto been invisible, and by careful technique have counted the number of such submicrons in a given volume of the liquid. The kinetics of Brownian Movement could be investigated with vastly smaller particles than it had previously been possible to observe, and, probably most important, the concept of colloid chemistry as the *chemistry of special dimensions* was established. A vast array of such colloidal solutions which are homogeneous as far as the ordinary microscope is capable of determining, have been shown to be physically heterogeneous by means of the ultramicroscope.

<sup>1</sup> D. KONOVALOV, *Ann. Physik.*, **10** (1903), 360.

<sup>2</sup> SIEDENTOPF and ZSIGMONDY, *Ann. Physik.* (4), **10** (1903), 1.

Rayleigh<sup>1</sup> has shown that the intensity of the scattered light is inversely proportional to the fourth power of the wave length and the scattering by each particle is proportional to the square of the volume of the particle. Light scattered in this way is chiefly blue. The particles themselves are not seen, but only the light which is diffracted by them. Minute traces of dust or other impurities in the liquid are also observed in this way, and great precaution must be taken to insure against their presence when observations are being made, as otherwise one would obtain misleading results. Tyndall himself employed the method to determine if air was free from dust. Ordinary water shows a faint Tyndall cone, but when pure it is found to be optically empty, as are nearly all pure liquids and true solutions. Martin<sup>2</sup> has claimed however to have found that some organic liquids, even when absolutely pure, scatter light and so produce the Tyndall cone.

Since the particles are themselves not discernible, it would appear to be an imposition on good faith to endeavor to measure their size, but this may be done indirectly with a fair degree of confidence. The number of particles in a known volume is determined by counting under the ultramicroscope, and the mass and density being known the length of the side of one particle is calculated from the formula:<sup>3</sup>

$$L = \sqrt[3]{M/SN}$$

where  $L$  is the length of one side;  $M$ , the mass in unit volume;  $S$ , the specific gravity; and  $N$ , the number of particles in unit volume. This formula, however, is capable of expressing only the *average* size, and it is very probable that particles of greatly varying sizes may be present.<sup>4</sup>

The visibility of the separate particles depends upon their size and the relation between the index of refraction of the particles and that of the medium in which they are dispersed.

<sup>1</sup> RAYLEIGH, *Phil. Mag.* (4), **41** (1871), 107; 447.

<sup>2</sup> MARTIN, *J. Phys. Chem.*, **24** (1920), 478.

<sup>3</sup> Cf. G. KING, *J. Soc. Chem. Ind.*, **38** (1919), 4T; 3rd Report on Colloid Chemistry, British Assoc. Adv. Science (1920), 31.

<sup>4</sup> A. W. Thomas points out (personal communication) that the light reflections from many of the particles are too small to be resolved and hence are not counted, resulting in an overestimation of the size of the particles. Thomas regards all figures for the sizes of colloidal particles given in the literature as quite valueless.

Under the most favorable conditions particles as small as  $3\mu\mu$  have been discerned, but if the index of refraction of the two phases is identical or nearly so they become invisible, even if of large size. A common method for identifying precious stones and distinguishing between genuine and artificial gems is to place the crystal in a liquid which has an index of refraction identical with that of the genuine stone. If the sample under examination is genuine it will not then be visible, while the imitation stone will be readily seen in such a solution.

One of the difficulties in observing emulsoids under the ultramicroscope is due to the nearly identical index of refraction of the two phases. The actual intensity of the scattered light is likewise dependent upon the index of refraction. According to Lord Rayleigh:<sup>1</sup>

$$I_s \propto \left[ \frac{\mu_1^2}{\mu^2} - 1 \right]^2$$

where  $I_s$  is the intensity of the diffracted light;  $\mu$ , the refractive index of the medium; and  $\mu_1$ , that of the dispersoid. Thus as the indices of refraction of the two phases approach each other the intensity of the scattered light diminishes until at the point of exact coincidence it becomes zero. Suspensoids of metals as gold, silver, etc., dispersed in water make therefore the ideal conditions for examination, while hydrated emulsoids are much less easily observed. In these cases, however, the colors due to the selective reflection of the metals is dominant, and the true color of the Tyndall blue is not observable. In fact suspensoids of silver may be obtained which look red in the ultramicroscope.

The mechanics of the ultramicroscope and the technique of its operation should be thoroughly in hand before the making of dependable observations is attempted.<sup>2</sup> An extended discussion of these considerations would be out of place in a book of this kind, but the essential features may be briefly stated.

The *slit ultramicroscope* is the most generally used type of instrument, and is so called because the illuminating beam, entering the quartz windows of the observation cell, is controlled by means of a bilateral micrometer slit. This is so adjusted, in the Zeiss instrument, that the image is about  $\frac{1}{36}$  the dimensions of the slit. A definite area of the beam is observed by the use of a micrometer eyepiece, and the depth made less than the depth of normal vision, so that the product of depth and area gives the volume of

<sup>1</sup> RAYLEIGH, *loc. cit.*

<sup>2</sup> C<sup>o</sup> E. F. BURTON, "The Physical Properties of Colloidal Solutions" (1916), 28.



the solution actually observed. This is necessary where countings are to be made. The solution should be so dilute that only four or five particles are seen at one time in this volume, and a number of instantaneous counts made. This is required on account of the rapid Brownian movement taking place.

In the *cardoid ultramicroscope* a more intense illumination makes possible the visualization of smaller particles than are seen in the slit type. An *immersion* form of instrument has also been perfected by Zsigmondy,<sup>1</sup> and by its use particles as small as  $3\mu$  have been observed.

King<sup>2</sup> found that solutions of peptone, starch, gelatin, agar-agar, and dextrin were all optically empty, due probably to the similarity in the indices of refraction of the two phases. In a solution of aqueous alcohol, Bancroft<sup>3</sup> reports that it is possible to obtain gelatin in the form of a net structure made up of definite globules rather than filaments, and Bachmann<sup>4</sup> reports that it is impossible to distinguish between sponge and honeycomb structures in gels by means of the ultramicroscope. Elliott<sup>5</sup> has reported however that no difficulty should be experienced in observing the colloid particles of a gelatin sol in very dilute solutions. The author has found that gelatin sols which were hydrated to the minimum degree—(obtained by bringing gelatin to its isoelectric point, pH 4.7) and which when cooled to 15°C. readily precipitated—were easily observed under the ultramicroscope (at 15° the particles had attained microscopic dimensions) while under conditions of greater hydration the scattering of light rapidly became less pronounced, and could not be perceived at pH 3.5. This simple observation doubtless explains why some investigators have succeeded and others have failed to detect the presence of colloid emulsoid particles with the ultramicroscope. The degree of hydration of the particles examined is a critical factor.

Menz<sup>6</sup> observed that a strong Tyndall effect was produced in solutions of gelatin of from 1.0 to 0.1 per cent concentration, that a faint but non-resolvable light cone was apparent at concentrations of 0.01 per cent; and that at 0.001 per cent concentration the light cone was barely visible. He concluded, first, that protective action was due only to the very small

<sup>1</sup> ZSIGMONDY, *Kolloid-Z.*, **14** (1914), 281.

<sup>2</sup> G. KING, *loc. cit.*

<sup>3</sup> W. D. BANCROFT, "Applied Colloid Chemistry" (1921), 241.

<sup>4</sup> BACHMANN, *Kolloid-Z.*, **23** (1918), 89.

<sup>5</sup> F. ELLIOTT, 60th Gen. Meeting Am. Chem. Soc., Chicago, 1920.

<sup>6</sup> MENZ, *Z. physik. Chem.*, **66** (1909), 129.

amicroscopic particles, larger particles having no effect, and second, that the dispersion in aqueous solutions depended upon the concentration *after warming*, simple dilution with cold water having no effect whatsoever. A similar effect has been observed as regards structure (see below).

**12. The Donnan Equilibrium.**—Donnan's membrane equilibrium<sup>1</sup> is established when a membrane separates two ionized solutions, one of which has one ion for which the membrane is impermeable, while all of the other ions are readily diffusible through the membrane. This nondiffusible ion may be either a colloid or a crystalloid, but protein salts in electrolytic solutions constitute a typical case. A collodion membrane is suitable for the separation, it being impermeable to the protein ions but easily permeable to the ordinary ions of inorganic electrolytes.

When a gelatin chloride solution, for example, is separated from a solution of dilute hydrochloric acid by a collodion membrane, the distribution of the ions of the acid, after equilibrium is reached, is not the same on the two sides of the membrane. It is found to be higher on the side free from gelatin ions. This was shown by Donnan to be a necessary consequence of the second law of thermodynamics, and Procter<sup>2</sup> has deduced that the relative distribution of the acid on the inside and the outside of a solid block of gelatin chloride in equilibrium with hydrochloric acid is determined by the equation:

$$x^2 = y(y + z),$$

where  $x$  is the concentration of H ions (and of Cl ions) outside the gelatin,  $y$  the concentration of the H ions (and the Cl ions) of the uncombined HCl within the gelatin, and  $z$  the concentration of Cl ions in combination with the gelatin ions.  $x$  is obviously greater than  $y$ , which necessitates the concentration of free HCl on the outside being greater than on the inside of the gel.

Although Procter studied only the solid gel equilibrium, Loeb<sup>3</sup> has found the same condition to apply when a solution of gelatin chloride is separated from pure water by a collodion membrane. The Donnan equilibrium has been made use of in the development of theories of structure, swelling, osmotic forces, etc., by

<sup>1</sup> F. G. DONNAN, *Z. Electrochem.*, **17** (1911), 572; DONNAN and HARRIS, *J. Chem. Soc.*, **99** (1911), 1554; DONNAN and GARNER, *ibid.*, **115** (1919), 1313.

<sup>2</sup> H. R. PROCTER, *J. Chem. Soc.*, **105** (1914), 313; PROCTER and WILSON, *ibid.*, **109** (1916), 307.

<sup>3</sup> J. LOEB, *J. Gen. Physiol.*, **3** (1920-21), 247.

Procter,<sup>1</sup> by Loeb,<sup>2</sup> and by Miss Lloyd.<sup>3</sup> These theories are described elsewhere in this text, but it is desired to point out here some of the mathematical relationships that have been found between this equilibrium and the various effects of hydrogen ion concentration and valence upon the properties of proteins.

The difference in the concentration of acids on the two sides of the membrane must lead to a difference in the potential at the surface of the membrane. This P.D. (potential difference) may be calculated on the basis of Nernst's formula for concentration cells, which at 24°C. becomes:

$$\text{P.D.} = 0.059 \log \frac{C_1}{C_2},$$

where  $C_1$  is the H ion concentration inside the gelatin solution and  $C_2$  the H ion concentration in the outside solution. And since  $\log \frac{C_1}{C_2}$  is pH inside the gelatin solution minus pH outside the gelatin solution, it follows that

$$\text{P.D.} = 0.059 (\text{pH inside} - \text{pH outside}),$$

the P.D. being expressed in volts.

Loeb<sup>4</sup> has tested the validity of this postulation by a long series of convincing experiments. The potential differences were measured by a Compton electrometer. The gelatin solution was placed inside a collodion bag closed with a rubber stopper through which a funnel was introduced, and the electrode dipped into the solution which was caused to rise a little way into the funnel. The collodion bag was dipped into water or other electrolytic solution and the second electrode introduced into this. In practically all cases Loeb found that the P.D. calculated by multiplying the values of pH inside minus pH outside by 59 agreed very satisfactorily with the observed P.D. (in millivolts). Loeb furthermore demonstrated that the variation in P.D. with changes in hydrogen ion concentration, and with variation in the valence of the combined ion, was in all cases studied by him practically parallel with the changes that were induced by the

<sup>1</sup> See page 136.

<sup>2</sup> See page 157.

<sup>3</sup> See pages 167-8.

<sup>4</sup> J. LOEB, *J. Gen. Physiol.*, **3** (1920-21), 557; 667; 691; 827; **4** (1921), 73; 97.

same forces in the swelling, the viscosity, and the osmotic pressure of the solution.<sup>1</sup>

If the equation

$$x_2 = y(y + z)$$

is written in the form

$$\frac{y}{x} = \frac{x}{y + z},$$

then  $\frac{y}{x}$  = the ratio of H ion concentration inside over the H ion concentration outside; and  $\frac{x}{y + z}$  = the ratio of the Cl ion concentration outside over the Cl ion concentration inside. And since

$$\log \frac{y}{x} = \text{pH inside} - \text{pH outside},$$

and

$$\log \frac{x}{y + z} = \text{pCl outside} - \text{pCl inside},$$

it follows that

$$\text{pH inside} - \text{pH outside} = \text{pCl outside} - \text{pCl inside}.$$

Upon putting this to the test Loeb found that the values for pH inside minus pH outside were, for the same solution at the point of equilibrium, equal to the value pCl outside minus pCl inside.

The peculiar variations in the osmotic pressure of gelatin solutions upon changing the pH or the valency of the combined ion were also found to be not only qualitatively but almost quantitatively explainable and calculable by means of the Donnan equilibrium.

If  $y$  be the H and Cl ion concentrations of the free HCl inside a solution of gelatin chloride,  $z$  the Cl ion concentration of combined Cl ions within the gelatin solution, and  $a$  the concentration of gelatin ions and unionized molecules, then the osmotic pressure of the solution will be

$$2y + z + a.$$

When the measurement is made by observing the height in millimeters to which the solution will rise in a tube upon placing the gelatin solution, contained in a collodion bag, into water, the observed osmotic pressure will be less than the above by

<sup>1</sup> It is still necessary to explain the phenomena which take place in unionized systems, as, for example, the swelling of rubber or polymerized isoprene in, *e.g.*, carbon disulphide.



that component due to the pressure of the ions in the outside solution, or, letting  $x$  be the concentration of H ions outside, and  $P_o$  the observed osmotic pressure,

$$P_o = 2y + z + a - 2x.$$

$y$  is calculated from the pH inside,  $x$  from pH outside, and  $z$  from Donnan's equilibrium equation,

$$z = \frac{(x + y)(x - y)}{y}.$$

Since the theoretical osmotic pressure of a gram molecular solution in terms of mm. of water is expressed by

$$22.4 \times 760 \times 13.6 \times \frac{297}{273} = 2.5 \times 10^5,$$

then

$$(2y + z + a - 2x) \times 2.5$$

gives the calculated osmotic pressure of the gelatin solution expressed in terms of  $10^{-5}N$ .

The above equation satisfies a monovalent ion condition. If the anion of the gelatin salt is divalent, the equilibrium equation becomes one of the third degree, and is calculated from the values:

$$\frac{3}{2}y + \frac{z}{2} - \frac{3}{2}x.$$

Very good agreement between the observed values for the osmotic pressure of gelatin solutions, and those calculated by the above formulas have been reported by Loeb.

The value of  $a$ , the actual osmotic pressure due to the gelatin ions and molecules, was obtained by subtracting the pressure calculated for the inorganic ions:

$$P_{\text{Gelatin}} = P_o - [(2y + z - 2x) \times 2.5 \text{ mm. H}_2\text{O}].$$

Although the probability of error is large, Loeb concludes that the osmotic pressure due to the gelatin particles in a 1 per cent solution of gelatin phosphate of pH 3.60 is about 100 mm. H<sub>2</sub>O.

In order to explain also the viscosity variations upon changes in pH or other influences, Loeb finds it necessary to discard the older theories of structure and to propose a new hypothesis which will be known as the occlusion theory.<sup>1</sup> By assuming that gelatin solutions contain isolated ions and molecules of gelatin together with pieces of solid submicroscopic particles capable of occluding water, Loeb proceeds to demonstrate that the amount

<sup>1</sup> The occlusion theory is described on page 157.

of water that will be occluded under any given set of conditions, and the ratio of the solid to the ionic and molecular particles, will be controlled likewise by the Donnan equilibrium. The effective volume of the gelatin in solution will accordingly vary as the water occluded, and the viscosity will vary as this effective volume of gelatin. The osmotic pressure, on the other hand, is shown to vary reciprocally as the viscosity. That is, the larger the proportion of gelatin in the form of solid particles occluding water, the greater will be the viscosity, but the smaller will be the osmotic pressure, since the latter is dependent upon the ionic and molecularly sized particles, but if these ions and molecules are caused to increase in number at the expense of the solid particles, the viscosity will drop while the osmotic pressure will rise.

## II. THE STRUCTURE OF GELATIN

✓  
1. **The Older Theories of Gel Structure.**—The earliest recorded studies of the structure of gels were conducted by Frankenheim in 1835 and von Nägeli in 1858. Although the ultramicroscope had not then been invented they concluded from a study of the properties of gels that these consisted of a loosely bound network or aggregation of molecules or solid particles of submicroscopic size. This early work was placed upon a sounder basis by the long series of optical observations of Bütschli<sup>1</sup> between 1892 and 1900. From this time on to the present, an emulsion theory of gels has been, with numerous modifications, the most generally accepted theory to account for the characteristic properties of these substances.

Van Bemmlen<sup>2</sup> was one of the early champions of the conception of a structure in colloidal gels. He states in connection with investigations upon silicic acids that the semiliquid particles of the colloid arrange themselves with the water molecules to form "a cell-like structure of definite form," and that these cells "hang together at certain points, so forming a network." The water is then retained partly by the cells themselves and partly in the interstices between the cells. He finds that all of the properties of the colloids are in harmony with the view that the hydrogel is a cell-like structure or network.

<sup>1</sup> BÜTSCHLI, "Untersuchungen über mikroskopische Schäume und das Protoplasma," Leipsig, 1892; "Untersuchungen über Strukturen," Leipsig, 1900.

<sup>2</sup> J. M. VAN BEMMELEN, *Z. anorg. Chem.*, **13** (1896), 233; **18** (1898), 14.

Hardy<sup>1</sup> does not think it probable that any structure exists in gelatin so long as it is in the form of a solution, nor even in the form of an ordinary gel, but after it has been made irreversible by some hardening agent, as formaldehyde, mercuric chloride, or osmic acid, it then possesses a net structure, and bears a close resemblance to the finer structures of protoplasm. The nature of the structure produced he found to vary with the type of hardening agent employed, the concentration, and the temperature.

In 1901 Quincke<sup>2</sup> postulated a theory of the structure of colloidal solutions according to which such solutions are not homogeneous like water, but consist of a mixture of two phases, one rich in colloid and the other poor in colloid. A surface tension develops at the surface of contact of these two phases, with the result that the richly colloidal solution forms into cells which may be either full of the colloid-poor solution, or of uniform composition. The cells so formed may be isolated, or they may form chain-like threads or masses which cling together.

Garrett,<sup>3</sup> in a study of the changes in viscosity obtaining in solutions of typical colloids, *i.e.*, gelatin, albumin, and silicic acid, upon variation of the temperature and concentration, obtained results which led him to accept Quincke's theory and to extend somewhat and enlarge upon it. He found that "although the logarithmic decrement of a disk oscillating in water or other homogeneous fluid is constant, yet in a gelatin solution the decrement varied considerably, even when the temperature and concentration remained unchanged." In general the decrement increased with the time during which the disk had been immersed in the solution. In the case of solutions slowly cooled to the temperature under observation, the logarithmic decrement was a linear function of the time. There did not appear to be any definite maximum of decrement, but a fixed minimum was shown to exist, *i.e.*, the decrement—as found by interpolation—at the moment when the plate was introduced into the solution. This value was the only one which remained the same from day to day and with various solutions of the same strength. When the plate was taken out of the solution, well washed with hot water, cooled, and reintroduced, the same

<sup>1</sup> HARDY, *Am. J. Physiol.*, **24** (1899), 158.

<sup>2</sup> QUINCKE, *Sitz. kon. preuss. Akad. Wiss.*, Berlin (1901), 858.

<sup>3</sup> H. GARRETT, *Phil. Mag.* (6), **6** (1903), 374.



"anfangsdekrement" was obtained. Furthermore, the decrement was found, below a certain temperature, to increase continuously whether the plate was washed or not; in dilute solutions (1 to 3 per cent) the decrement observed after a few large vibrations was smaller than when observed with only small swings; and  $\beta$  gelatin, *i.e.*, gelatin that had been boiled for some time, did not show these characteristics.

Garrett explains the phenomena observed upon Quincke's theory. He assumes that "the colloidal cells which have fixed themselves upon the disk are carried by it through the liquid and come in contact with new cells, so that the mass of cells hanging onto the plate increases, and with it, the resistance to vibration, or, in other words, the logarithmic decrement. If the oscillation is too large the cell walls will be drawn out and become thinner; the thickness of the wall may become less than twice the distance of the action of molecular force ( $2l$ ) in which case the surface tension becomes less. The thickness of the cell wall may even become zero, and the cells then tear themselves entirely away. Hence after a large oscillation the damping will be less than after a small one. Continued boiling destroys the cells and a gelatin solution then behaves as a homogeneous fluid."

By experiments upon the diffusion of solutions through gelatin jelly, Bechhold and Ziegler<sup>1</sup> also came to favor a net structure theory. They caused a precipitate to be formed in the interior of a strip of gelatin by allowing the proper reagents to diffuse into it from opposite sides, and noted the nature of the permeability of the films so produced. They concluded that the jelly acts as a network of gelatin with pores filled with water, through which alone the diffusion takes place. The rôle of the precipitate is merely the filling of these pores and the consequent prevention, partial or complete, of the diffusion.

Sutherland<sup>2</sup> in 1906 added a new conception to the structure of colloids. He affirmed that "the characteristic of the colloid state is that the molecules cease to have a separate existence; they link on to one another by means of the atomic electric charges, thus forming the meshes so characteristic of colloids. Each particle in a suspension (of globulin) might therefore be called a molecule, but with no advantage. In each such particle, however, a certain pattern is repeated in three-dimensional

<sup>1</sup> H. BECHHOLD and J. ZIEGLER, *Ann. Physik.* (IV), **20** (1906), 900.

<sup>2</sup> N. SUTHERLAND, *Proc. Roy. Soc. (London)*, **79B** (1907), 130.



space." This pattern, Sutherland denotes as a *semplar*. The basis of this theory rests upon the conception of neutralized valencies within the molecule. Thus in  $\text{NH}_3$  the valence of the N is 5, as in  $\text{NH}_4\text{Cl}$ , these five consisting of four negative and one positive valence. In the compound  $\text{NH}_3$  three of the negative valencies are combined with the three positive valencies of the hydrogen, and the remaining positive and negative valence are combined with each other forming a *doublet*. Such doublets Sutherland believes are the cause of cohesion and rigidity. Now if each doublet in the compound  $\text{NH}_3$  is broken by some force, and the positive valence of one molecule is caused to combine with the negative valence of its neighbor, then each molecule of  $\text{NH}_3$  becomes a *semplar*, and the whole system becomes a mesh of such *semplars*. The actual linking up of molecules in such manner is however, according to Sutherland, usually confined to groups, each group containing a limited number of molecules. If this number,  $m$ , is small and definite, as in water (dihydrol,  $(\text{H}_2\text{O})_2$ ) and ice (trihydrol,  $(\text{H}_2\text{O})_3$ ), the material will be crystalloid, but when  $m$  becomes large and indefinite, then the substance is in the colloidal state.

This theory Sutherland applies to proteins (globulin) by assuming solutions of such to contain a large and indefinite number of such "semplar" combinations. The action of acids or other solvents upon these is to break down the doublets permitting of a salt formation.

Wo. Ostwald<sup>1</sup> is of the opinion, with Garrett, that gelatin, even in solution, possesses a structure. His explanation of the influence of heat upon gelatin solutions is based on the supposition that the structure is partially destroyed by heating. He has further observed that the influence of added salts upon the swelling of gelatin plates in water is similar in character to their influence upon the viscosity of gelatin solutions, "that the degree of swelling runs closely parallel with the diminution in viscosity of solutions, as determined by von Schroeder, since the concentrations of salts at which maxima of swelling occur are nearly identical with those at which minima in the viscosity of solutions are observed." Ostwald concludes from this that the passage of gelatin into solution does not destroy the structure of the gel but that this structure persists in solution.

<sup>1</sup> Wo. OSTWALD, *Arch. ges. Physiol.*, 109 (1905), 277; 111 (1906), 581.

## 2. The Recent Theories of Gel Structure. *Procter's Theory.*—

Procter<sup>1</sup> pictures a compound of gelatin with an acid as a coherent mass from which the gelatin cannot diffuse or separate, and which in its essential characteristics behaves like a single large and complex molecule. He visualizes it as a felted mass of amino-acid chains held to each other by attractions which possibly attach only their ends, but freely admit of the passage of liquid between them. Such a structure explains, according to Procter, the osmotic effects which result in a swelling of gelatin when immersed in water or dilute acids. The latter have free passage through the gelatin, but the anions of the acid combine with the gelatin cations forming a salt which, although it may be highly ionized, is prevented from diffusing out into the solution on account of the immobility of the gelatin ions and the consequent electrostatic limitation of the outward diffusion of the anions. Since they cannot move outward, the osmotic forces are compensated only by the inward movement of water resulting in swelling.

*Robertson's Theory.*—Robertson<sup>2</sup> is impelled to believe that the type of viscosity which solutions of proteins exhibit may in some manner owe its existence to a structure rather than an internal friction which merely hinders molecular and ionic motion. He suggests that "a netlike structure, such as a tennis net, will offer no hinderance to the passage through it of a quickly moving body which is smaller than its meshes, other than that which is due to the fact that the material which composes the net occupies a small fraction of the area which the body must traverse, but to any force which involves deformation of the structure, for instance, a force which seeks to drag it through a small tube, it will offer a very considerable resistance. On the other hand the resistance which is offered to a small moving body by a viscous liquid (viscous, that is, in the ordinary sense) is accurately measured by the resistance which the liquid offers to passage through a tube." The direct methods for determining viscosity, as the passage through a capillary tube or the rotation within the liquid of a suspended disk, are all such as would involve a deformation of any existing structure, and consequently are not competent as means for distinguishing between true internal friction and viscosity due to a structure. The indirect method of

<sup>1</sup> H. R. PROCTER, "*Collegium*" (1915).

<sup>2</sup> T. B. ROBERTSON, "Physical Chemistry of the Proteins" (1918), 325.

measuring viscosity by determining the conductivity reveals however only that viscosity that is due to true internal friction, and when this method is applied to proteins, the presence of the protein is found to leave the viscosity of the solvent practically unaltered.

That a net structure is not confined to protein or colloid substances, but may in fact be present in most or all solutions of electrolytes is urged by Robertson from the fact that in watery solutions the hydrogen and hydroxyl ions are the most rapidly moving, while in other solvents this may not be the case, but instead those ions which by their combination give rise to the solvent. That viscosity measurements of crystalloidal electrolytes have not so far revealed the presence of a net structure within them is tentatively attributed by him to "the tenuity of the net and to the fineness of its framework; to revert to the analogy employed above, a net of the finest and most flexible silk will readily pass without appreciable resistance through a tube which would offer a considerable resistance to the passage of a net of coarse thread." The structure of the protein molecule becomes observable by viscosity measurements only through the enormously greater size of its molecules.

Loeb<sup>1</sup> observed the enormous increases in viscosity which resulted from merely keeping a gelatin in a refrigerator for a number of hours and then warming to 24°C. for the measurement. Immediately after melting, his viscosity determinations showed values ranging from 86 to 102, while after leaving in the refrigerator for one hour and then warming, they had increased to 130 and 143, and after 18 hours in the refrigerator they had risen to 180 and 250. However, by first heating to 50° and cooling to 24°, the viscosity again became normal. These data are shown in the following table.

If the structure is responsible for the viscosity, as seems probable, these results can only mean that the standing at a low temperature in some way favors the development of the structure, while heating to a high temperature tends to destroy it.

*McBain's Theory.*—McBain and his collaborators<sup>2</sup> have studied

<sup>1</sup> J. LOEB *J. Gen. Physiol.*, **1** (1919), 495.

<sup>2</sup> Cf. J. W. MCBAIN and C. S. SALMON, *J. Am. Chem. Soc.*, **42** (1920), 426; J. W. MCBAIN, 3rd. Report on Colloid Chemistry, British Assoc. Adv. Science (1920), 2; and M. E. LAING and J. W. MCBAIN, *J. Chem. Soc.*, **117** (1920), 1506.



the structure of soap solutions in connection with the development of their micelle theory<sup>1</sup> which they apply to all colloidal electrolytes. As the evidence in the case of these soap gels is much more direct than has been found for proteins, and as there is much reason to believe that the structure relationships are

TABLE 33.—VARIATION IN VISCOSITY OF GELATIN SOLUTIONS ON STANDING

Treatment, all measurements made at 24°C.	Na gelinate	K gelinate	Mg gelinate	Ca gelinate
Immediately after melting..	99.0	102.0	88	86.0
After 1 hour in refrigerator.	135.0	143.0	138	130.0
After 18 hours in refrigerator.....	180.0	250.0	240	200.0
After 18 hours in refrigerator and being kept at 24° for 2 hours.....	170.0	210.0	194	173.0
After 18 hours in refrigerator, heating to 50°, and cooling to 24°.....	94.5	95.5	86	83.5

very similar in the two cases, a description of McBain's findings will not be out of place. His work has led him towards the opinion that "in a gel there exist well developed strings of long molecules forming an exceedingly fine filamentous structure which accounts for the elasticity of gels and also for the fact that they exhibit more or less clearly oriented properties such, for instance, as the lenticular, fairly definitely oriented, form of bubbles generated within gels."

McBain believes that the same forces are in play as account for the phenomena of crystalline liquids and liquid crystals. Such a conception would serve to explain, for example, the incipient structure which most sols develop on standing and which is such as prevents definite measurements of viscosity from being taken independent of age and rate of shear.

In a study of vanadium pentoxide sols which had been aged for many years, Freundlich found that at the boundaries and throughout the sol, whenever the sol was set in motion, it was anisotropic, and exhibited all the behavior of a crystalline liquid. From Vorlander's observations that long molecules are required

<sup>1</sup> *Vide* page 264.



for the formation of liquid crystals, it is believed that the behavior of Freundlich's sols is also attributable to this condition.

These strings of molecules in colloid sols may, according to McBain, be microns or millimeters in length "in other words they consist of innumerable molecules placed lengthwise and their formation would, of course, be ascribed to residual affinity." This links up Sutherland's "semplar" theory of the breaking of doublets with the later conceptions of structure.

In one instance McBain was able to observe and photograph a cloudy gel of sodium oleate which, "in addition to curd fibers, contained an exceedingly fine and delicate filamentous network. The quartz surfaces in contact with these gels often exhibit indefinitely long and exceedingly fine filaments just on the limits of visibility and just capable of being photographed with long exposures. Their regularity of form and texture is astounding. They simulate living matter in their appearance, they may take the form of a simple sine wave, or of regular waves with higher harmonic series superimposed on them. Any one part of such a filament is identical in form and structure with any other part. They are probably derived from originally straight just resolvable translucent tubes containing very regularly spaced whitish dots or lengths."

In the case of sodium soaps the curds were invariably found to consist of fine fibers. These might be many centimeters in length but in thickness are never greater than one micron. Most of them are even of ultramicroscopic diameter, and the thicker ones are probably parallel bundles of finer ones. "These fibers are often so fine that shorter or unattached fibers exhibit Brownian movement when the medium is not too viscous. These curd fibers constitute the only mechanical structural element of sodium soap curds and represent the stable condition of such curds even after the lapse of years."

The effect of temperature on viscosity is readily explainable upon the assumption that the films increase in number or length with decreasing temperature. That such takes place in soap curds is affirmed by McBain, who finds that "at the temperature of initial solidification only a few fibers are formed, the bulk of the soap remaining in the solution which therefore exhibits a practically undiminished vapor pressure and conductivity. As the temperature is lowered the solubility of the curd fibers rapidly diminishes until the enmeshed liquid consists chiefly of

water, and its vapor pressure and conductivity behave accordingly. Throughout this range of temperature the stable condition of the soap solution is the formation of the appropriate amount of curd fibers with enmeshed gel. The definite solubility of the curd fibers at any one temperature is evinced by the fact that the conductivity of a well aged curd is approximately independent of the concentration of the original soap."

In the later work of McBain and his coworkers they urge that a gel and sol are identical except for differences in mechanical properties. They contend that the exact coincidence of osmotic activity, electromotive force, and conductivity alike prove that the chemical equilibria are identical in sol and gel. And they insist further that "since the conductivity of concentrated gel and sol is thus identical, the hypothesis of a closed cellular, spongy, or honeycomb structure or other similar structure is disproved, and even a similar structure with partly open pores is rendered extremely unlikely." They find, however, that there is a distinct tendency for the colloid gels to form long strings of molecules or colloidal particles, and attribute the elasticity of gels to the exceedingly fine, filamentous structure so produced. Each of these innumerable threads consisting of colloidal particles stuck together would be capable of exhibiting mechanical elasticity. On account of the amicroscopic size of the particles and of the threads any displacement of them in the liquid would meet with such great frictional resistance that the property of elasticity would be transmitted to the whole mass of gel. This conception of gel structure may account for the various characteristic properties which they exhibit, and especially for the more or less clearly oriented properties, as the lenticular form of bubbles generated within gels, and the phenomenon of syneresis. "Thus if there is an orienting force between the particles, there must necessarily be in that force a component of attraction, and hence the gel structure of oriented particles must exhibit a distinct tendency to shrink. Even if this attractive force is only feeble, it must in course of time produce syneresis, since in dilute gels it is opposed only by the viscosity of a fluid. The swelling of gelatin salts is not in conflict with this view, because the ionic micelle of gelatin and proteins, unlike that of soap, does not become crystalloidal in dilute solution, and so continues to be retained within the gel."

The only possible conceptions of the nature of the colloidal

particles which link together to form the gel structure are, according to McBain's views, neutral colloid or ionic micelle. It may even be that all of the former is included in the ionic micelle, in which case the conducting particles are identical with those which by orientation give to the gel its structure.

Bachmann<sup>1</sup> had previously found evidence that when soap solutions set to a jelly long threads are formed. It seemed probable to him that these threads eventually passed over into or rearranged themselves into a net structure.

*Bancroft's Theory.*—Bancroft<sup>2</sup> considers that in gelatinous precipitates we may have either a honeycomb or a sponge structure. Viscous drops may partially coalesce to form filaments or films, or spherical drops of water may become coated with the gelatinous material. The latter condition would give rise to the honeycomb structure, while the former condition would produce an interlacing or sponge structure, each phase being continuous. The latter conception seems to be the one more generally accepted.<sup>3</sup> Bancroft has remarked that the fact that ultrafiltration may be carried on through a gelatin or collodion membrane argues strongly in favor of a porous structure in those cases, but this does not follow for a continuous membrane that was semipermeable in the sense of being able to dissolve the solvent or medium of dispersion would likewise behave as an ultra-filter.

Bancroft<sup>4</sup> regards a dilute colloidal solution of gelatin in water as consisting essentially of turbid drops of a gelatin-rich phase dispersed in water. On increasing the concentration of gelatin a tendency will become manifest for the separate drops to coalesce to form larger drops, or, if too viscous to do this, they may only partially coalesce, forming threads or a "chain of beads." It is not even necessary, in the latter case, that the droplets should be in actual contact. Where the droplets are of different sizes, the small ones will tend to group themselves about the larger ones. As the concentration of the gelatin becomes greater, loose chains may be formed which will finally pass into a net or

<sup>1</sup> BACHMANN, *Kolloid-Z.*, **11** (1912), 145.

<sup>2</sup> W. D. BANCROFT, "Applied Colloid Chemistry," New York (1921), 239.

<sup>3</sup> Cf. QUINCKE, *Ann. Physik.*, **10** (1903), 482; **14** (1904), 489; ZSIGMONDY, *Z. anorg. Chem.*, **71** (1911), 356; BACHMANN, *ibid.*, **73** (1912), 125; FLADE, *ibid.*, **82** (1913), 173.

<sup>4</sup> W. D. BANCROFT, *lib. cit.*, 242.



sponge structure. In such a system both phases will be continuous, and an interlacing of the phases exist. By still greater increase in the gelatin concentration, water may become dispersed as droplets in a gelatin-rich phase, which is the conclusion arrived at by Hardy<sup>1</sup> from experiments on the compression of jellies. We have however no data which permits us to speculate upon the extent to which increases in concentration of the gelatin result in a filling up of the solution with chains or filaments of the same diameter or upon the increase in diameter which these filaments undergo.

Bancroft believes that the previous history of a jelly will manifest itself in the rate and amount of swelling only in case the walls of the porous cells are fairly rigid and do not unite when brought into contact, as by the drying out of the cell. If the walls are not rigid they may collapse to such an extent that the pores will almost completely disappear, and in that case the swelling will be independent of the previous history of the jelly. While not entirely satisfactory, this explanation is the best we have seen to account for the differences observed in the swelling of gelatin which has been made from solutions of different concentrations. It will be recalled that if gelatin solutions are made at concentrations of say 10, 20, and 30 per cent, and allowed to dry out to a uniform concentration of say 90 per cent, on immersion in water the three will take up the liquid in different amounts: that made from the 10 per cent solution will take up water rapidly until its concentration is again 10 per cent, while that made from the 30 per cent solution will take up much less water, *i.e.*, it will go rapidly to a 30 per cent gel but only slowly beyond this point. By Bancroft's hypothesis this would mean that the cross-section of the filaments were different in the several cases, depending upon the concentration of the heated solution. It would appear that this cross-section increased with the concentration, making the cell wall more rigid. This rigidity in turn permits of less expansion and consequently of less water adsorption per unit of mass than if the walls were thinner and capable of occupying a greater volume. It may be mentioned that the ultramicroscope is incompetent as a means for differentiating between a sponge structure and a honeycomb structure in gelatin jellies.<sup>2</sup>

<sup>1</sup> HARDY, *Z. physik. Chem.*, 33 (1900), 326.

<sup>2</sup> BACHMANN, *Kolloid-Z.*, 23 (1918), 89.



*Other Theories of Gel Structure.*—The experiments of von Schroeder<sup>1</sup> upon the different degrees of swelling observed in water and in saturated water vapor also favor a theory of cellular structure. He found that gelatin immersed in water imbibed 1000 per cent of water, and when placed in an atmosphere of saturated water vapor, only 400 per cent. This must mean that the vapor pressure of water in gelatin is higher than the vapor pressure of pure water, for water distills from the gelatin to the vapor phase.

This curious anomaly may be accounted for upon the grounds of a cellular structure. If a sponge, for example, is placed in an atmosphere of water vapor, the cellular structure will absorb a certain amount of water upon its surface, but water will not condense in the interior of the cells. If placed in liquid water, however, the water will not only be absorbed upon the surface, but will also fill the cells, and if the sponge is then taken from the water, and placed in the vapor phase, water will distill from the curved capillary pores and surfaces of the sponge to the plane surfaces in the containing vessel, which is what von Schroeder observed in the case of swollen gelatin.<sup>2</sup>

Thompson<sup>3</sup> and Wilson<sup>4</sup> have also urged the necessity of assuming a three dimensional network, in any continuous mass of gelatin, made up of chains of atoms forming a network with interstices very much larger than the simple molecules or ions, although still too small to be detected microscopically. This viewpoint is a necessary assumption in Wilson's theory of the action of acids upon gelatin.<sup>5</sup>

The existence of a crystalline structure in gelatin gels has been urged by Bradford<sup>6</sup> and tohers. Bradford claims to have obtained gelatin crystals by the following procedure. A small amount of a high grade commercial gelatin was heated to boiling in water to which a trace of mercuric chloride had been added. This was then filtered and allowed to stand in covered crystallizing dishes. On the thirtieth day the residue showed, under the

<sup>1</sup> VON SCHROEDER, *Z. physiol. Chem.*, **45** (1903), 109. *Vide* also page 167.

<sup>2</sup> Wolff and Buchner and D. J. Lloyd have failed to confirm the findings of von Schroeder. See pages 167-8.

<sup>3</sup> F. C. THOMPSON, *J. Soc. Leather Trades' Chem.*, **3** (1919), 209.

<sup>4</sup> J. A. WILSON, *J. Am. Leather Chem. Assn.* (1920), 374.

<sup>5</sup> *Vide* page 179.

<sup>6</sup> S. C. BRADFORD, *Biochem. J.*, **14** (1920), 91.

microscope, numerous single spherites of 0.25 to 0.28 $\mu$  in diameter, and many clusters of these spherites.

Scherrer<sup>1</sup> has studied gelatin, among other organic and colloid substances, by means of the Röntgen photograph, and has been able to find no trace of interference figures arranged in a manner characteristic of the space lattice, which, if present, would indicate crystallinity. Some other gels, as silicic acid and stannic acid gels, exhibited well marked crystalline interference figures in addition to the characteristics of amorphous substances. Scherrer concludes that the latter represent substances that are at the point of crystallizing. The gelatin (and other protein gels) consists, therefore, of colloid particles which are composed either of individual molecules, or of groups of molecules that are *irregularly* orientated.

Fischer<sup>2</sup> considers that there are three possibilities: at high temperatures a true solution of gelatin in water; below this, (liquid) hydrated gelatin in solution of gelatin (the so-called sol) and if the temperature is reduced sufficiently and enough solvent is present, this liquid hydrated gelatin becomes solid hydrated gelatin (crystalline) in gelatin solution. If the solvent is limited a reversal in type of system occurs to liquid or solid hydrated gelatin holding within itself gelatin solution.

From data obtained in a study of the swelling of gelatin in acid and alkali,<sup>3</sup> Miss Lloyd<sup>4</sup> concludes that gelatin gel consists of a solid and a liquid phase, both of which are continuous. In the isoelectric condition the gelatin becomes "precipitated at numerous crystallization centers: the solid drops will run together to form a framework, but since there can be no osmotic forces in the system the framework will contract under the action of its own surface forces, and the internal phase will be squeezed out. Therefore the gel state as a two-phase system cannot exist as a stable system at the isoelectric point." In strongly acid or alkaline solution the gel form cannot exist, and this is taken by Miss Lloyd to signify that gelatin *salts* cannot form gels. The process of gelation is therefore pictured as follows: "gelation will only occur on the cooling of a sol which contains in solution iso-electric gelatin, and gelatin salts in equilibrium with free

<sup>1</sup> P. SCHERRER, *Nachr. Kgl. Ges. Wiss. Göttingen* (1819), 96.

<sup>2</sup> MARTIN FISCHER, personal communication.

<sup>3</sup> See pages 167-8.

<sup>4</sup> D. J. LLOYD, *Biochem. J.*, **14** (1920), 162.

electrolytes. As the sol is cooled the insoluble isoelectric gelatin is precipitated in a state of suspended crystallization and forms a solid framework throughout the system. The more soluble gelatin salts remain in solution, and by their osmotic pressure keep the framework extended. Gels therefore are two-phase systems, the solid phase consisting of isoelectric gelatin, the liquid of gelatin in the salt form."

### 3. The Theories of Sol Structure and the Sol-Gel Equilibrium.

Although a sponge or honeycomb structure may exist in the case of gelatin gels it seems highly improbable that such a structure is present in the sol condition. That some kind of a structure is present however, seems indisputable from such evidence as the influence of previous history of a sol upon the viscosity or upon the swelling when again permitted to dry out, and upon the influence of long standing, especially in the cold, upon viscosity.

The conception of a catenary or thread-like structure has been suggested by the author<sup>1</sup> to account for the behavior of gelatin sols. By this conception the individual molecules may be regarded as the separate links of the chain, while the colloid aggregate is represented as the catenary thread. An alteration in what is commonly spoken of as degree of dispersion may be regarded either as an alteration in the length or the number of these threads, or a change in the hydration of the molecules, or a combination of these influences. An interesting analogy to this condition is the acid agglutination of bacteria which Bordet<sup>2</sup> and Arkwright<sup>3</sup> have separately pointed out belongs to the same class of reactions as the coagulation by hydrogen ions or electrolytes of amphoteric colloids. If the analogy is correct, electrolytes may bring about coagulation in protein sols by a flocculation or bunching together of the catenary threads into aggregates of such size that the influence of gravity becomes more effective than the kinetic effects of Brownian movement. The existence of a fibrous or filamentous structure in such precipitates is beginning to be recognized, and it seems that the analogy is a sound one.

None of the lines of evidence that have been advanced for the existence of a net structure in gelatin sols are inconsistent with

<sup>1</sup> R. H. BOGUE, *Chem. Met. Eng.*, **23** (1920), 61.

<sup>2</sup> BORDET, *Cent. Bakt.*, **54** (1910), 150.

<sup>3</sup> ARKWRIGHT, *Z. Immunität*, **22** (1914), 396.



the conception of a catenary structure, while an intermingling of these threads would result in the formation of a mesh which would give all of the evidences and ultramicroscopic appearance of the net structure which is generally claimed for the gel state. Any deformation in these threads of molecules would likewise reveal itself in viscosity measurements by making such determinations abnormally high, and by producing variations, such as were observed by Garrett, in the logarithmic decrement of a disk oscillating in a medium in the presence of such threads.

The conception of the mechanism of protein ionization is also readily accounted for by this hypothesis. Robertson<sup>1</sup> observed a serious inconsistency in the net structure theory. He pointed out that the abnormal viscosity of proteins is usually said to be attributable to the net structure of their sols, and that it also appears to be closely related to the ionization of the protein. Therefore the net structure within the protein sol must be built up of protein ions. But such a conclusion is altogether incompatible with the generally accepted view of ions as we consider them to exist in solutions of electrolytes. The latter are regarded as "mutually independent and physically discrete bodies," but the net structure conception of an ion "appears to invite a distinction between the mode of ionization of ordinary electrolytes and that of protein salts." But a catenary aggregate or string of molecules may, without an undue stretch of the imagination, be regarded as capable, by opening up of their —CONH— groups, or by reactions involving terminal —NH<sub>2</sub> or —COOH groups, of forming a salt and of ionization, and without losing its identity act in every way as an independent and discrete body, capable of developing osmotic pressure, of conducting the electric current, and, in general, of carrying out the reactions associated with ions in electrolytes.

Since heating breaks up whatever structure may exist in gelatin sols, and shaking or beating tends towards the same result, it seems equally reasonable to expect that long standing, especially at low temperatures, would produce the opposite effect, with the formation of exceptionally long threads. The abnormal viscosities obtained by such a procedure seem to indicate that this is the case.

Gelatin sols appear therefore to consist of slightly hydrated

<sup>1</sup> T. B. ROBERTSON, "The Physical Chemistry of the Proteins" (1918), 325.



molecules united together into short threads resembling streptococci. These threads<sup>1</sup> are probably very short, but should be capable of exhibiting mechanical elasticity roughly proportional to their length. Procter<sup>2</sup> thinks that at 70°C. the solution becomes probably nearly molecular.

A lengthening of these threads seems to take place as the temperature falls, and at the same time the water absorbing power of the gelatin increases.<sup>3</sup> This accounts for the rapid increase in viscosity with drop in temperature. At temperatures above 40°C. the change in length of thread, or water absorption, per unit change in temperature is small, but at 30°-20° the change is very great. A solid jelly will result only when the relative volume occupied by the swollen molecular threads has become so great that freedom of motion is lost, and the adjacent heavily swollen aggregates cohere. The rigidity seems to depend on the relative amount of free solvent in the interstices of these aggregates, and on the amount of solvent that has been taken up by the gelatin in a hydrated or imbibed condition. The resiliency or elasticity is probably dependent upon the length and number of the catinary threads. A solution, or change from the gel to the sol form, may result only through the reversal of these processes, that is, a release of a part of the water retained by the heavily swollen molecules, and a partial disintegration of the long enmeshed fibrils of the gel. Any tendency on the part of the fibrils towards an orientation would imply an attractive force between them which would result in a shrinkage. This becomes manifest in syneresis. That some such orienting force does exist is indicated by the lenticular form of bubbles that are generated within gels. The degree of swelling that may be produced in cold water or electrolyte solutions is probably determined by osmotic forces, as described by Procter, and may be controlled by observing the principle of the Donnan Equilibrium as shown by Procter and by Loeb.

<sup>1</sup> J. Loeb has found the assumption of a few united molecules to account for the differences in the osmotic pressures of calcium and sodium gelatinates (*J. Gen. Physiol.*, **1** (1919), 496.)

<sup>2</sup> H. R. PROCTER, Report of the Faraday and Physical Societies (1921), 41.

<sup>3</sup> Whether or not this is real hydration is undetermined. H. C. Jones (*J. phys. Chem.*, **74** (1910), 325) has shown that the hydration of molecules and ions increases with a fall in temperature, and McBain and Salmon (*J. Chem. Soc.*, **119** (1921), 1374) have reported an increase in the hydration of soaps upon a lowering of the temperature.

The property of elasticity is, in the fluid state, synonymous with plasticity, for, on account of the amicroscopic size of these particles and the short threads characteristic of the sol state, any displacement of them in the fluid would meet with so great a frictional resistance that the property of elasticity, or plastic flow, would be transmitted to the whole mass. This conception seems to be in agreement with the theory of McBain and his collaborators<sup>1</sup> with respect to the sol and gel structure in soaps.

The transition from the sol to the gel forms, and *vice versa*, is not, therefore, a critical change, as occurs, for example, when a crystal of benzol changes to the liquid state. Indeed it no longer seems pertinent to regard the gel and sol forms as distinct phases in the classical sense, but rather as different forms of the same state. Since this is the only conclusion it seems justifiable to draw, it would appear difficult to conceive that a concise *point* of transition from the one form to the other could exist. There is, rather, a *period* through which the transition is especially marked by virtue of rapidly changing physical properties.

None of the instruments that have been devised for measuring molecular or molecular group elasticity (plasticity) are in any sense absolute: *e.g.*, there is a sensitivity coefficient below which they cease to function. In other words, while we can say definitely that paint, for example, is a plastic solid or shows properties of plastic flow, we cannot say as positively that water exhibits no such properties. All that we may say is that, as far as the most delicate sensitivity of our instrument reveals, there is no indication of plastic flow in water. Theoretically there is no reason to believe that liquid water (dihydrol) should not possess intermolecular elasticity.

With the instrument made use of in the author's<sup>2</sup> experiments on plasticity (the MacMichael viscosimeter) the highest temperature at which evidences of plastic flow were observed (in 25 per cent concentration) was about 34°C. A more delicate instrument might show this property at a higher temperature. As the concentration of the gelatin solution was decreased, the maximum temperature where plastic flow was first observed became lower, *e.g.*, about 33° in the 20 per cent concentration, and 29° in the 10 per cent concentration. This is in entire conformity with the argument presented above. For while it

<sup>1</sup> See M. E. LAING and J. W. McBAIN, *J. Chem. Soc.*, **117** (1920), 1506.

<sup>2</sup> R. H. BOGUE, *J. Am. Chem. Soc.*, **44** (1922), 1313. (See page 207.)

was stated that the plasticity was an expression of interfibril elasticity, and that elasticity was determined by the length of the fibrils, it also follows, from the limited sensitivity of our apparatus, that the *measureability* of this property must depend upon the actual concentration of fibrils in the solution. And this is proportional to the total concentration of gelatin in the solution at any given temperature.

Davis and Oakes<sup>1</sup> have reported that at the temperature of 38.03°C. gelatin sol and gel can exist in equilibrium, while this is not true for any other temperature. That is, a "seeded" solution (one to which a little gelatin gel had been added) showed no change in viscosity with time at the temperature of 38.03°. At any temperature below this a regular increase in viscosity with time was observed. At higher temperatures a decrease occurred until the viscosity equalled that of a similar unseeded portion at the same temperature. Sheppard<sup>2</sup> has been able to very closely corroborate this value, but Loeb<sup>3</sup> has reported that at any temperature above 35°C. the viscosity (of a 2 per cent solution of gelatin chloride of pH 2.7) *decreases* on standing.

In order to bring more data to bear upon this point a series of experiments was performed<sup>4</sup> with the object of noting the changes in viscosity with time, of gelatin solutions of varying pH and of varying concentration. The data, shown in part in Fig. 16, indicate a decrease in viscosity with time at every pH value tested, from 2.0 to 9.4, with the exception of the sample at 4.7 in which case there was no change. The sample at 4.8 was "seeded," but no alteration in the slope of the curve was observed. The nearer the pH of the samples to the isoelectric point, the less the variation in viscosity with time. There was in no case however an increase in viscosity with time.

A gelatin that had been purified by dialysis was also subjected to the same treatment, and although the curves were in most instances very similar to the previous ones, yet at pH 4.7 there was a slight tendency for an increase in viscosity with time as indicated by the dotted curves in Fig. 16. At 37.0° the curve was again horizontal.

<sup>1</sup> C. E. DAVIS and E. T. OAKES, *J. Am. Chem. Soc.*, **44** (1922), 464.

<sup>2</sup> S. E. SHEPPARD, Discussion at 62nd Meeting, Am. Chem. Soc., New York, Sept. 6-10, 1921.

<sup>3</sup> J. LOEB, *J. Gen. Physiol.*, **4** (1921), 107.

<sup>4</sup> R. H. BOGUE, *J. Am. Chem. Soc.*, **44** (1922), 1343.



The significance of these data is now apparent. There are obviously many factors which influence the effective volume of the gelatin in the solution. Of these the pH seems to be most important. The amount and nature of the inorganic ions with

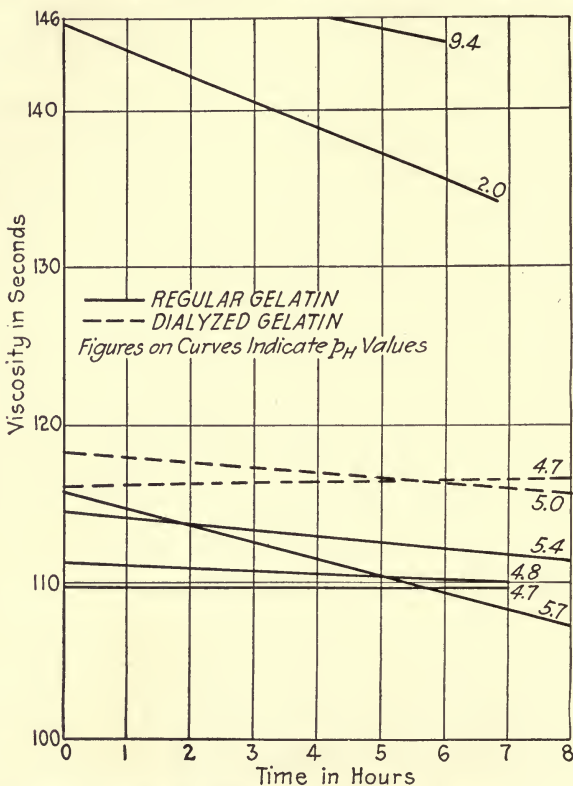

FIG. 16.—Change in viscosity with time at varying pH, 2 per cent solution, 35°C.

which the gelatin is associated is another. The presence of the hydrolysis products of gelatin is a third factor. And the measurability of these influences will be determined by the concentration. At low temperatures, *e.g.*, 25°, the tendency in the system is for an increase in the size of the molecular aggregate. Hence an increase in viscosity with time. At high temperatures, *e.g.*, 40°, the tendency is for a decrease in the size of this aggregate. Hence a decrease in the viscosity with time. At any specific temperature, *e.g.*, 35°, whether the aggregate will become larger or smaller is determined by the pH of the solution, and the



presence of inorganic ions and protein hydrolysis products. Under any given set of conditions there will be some temperature at which neither increase nor decrease will occur. This point was found in gelatins studied by Davis and by Sheppard to be at about 38°; in gelatins studied by Loeb to be at 35° (in solution of pH 2.7); and in gelatins studied by the author to be at 35 and 37° (in solution of pH 4.7).

It appears that at elevated temperatures the colloid fibril consists of but a few partially hydrated molecules attached to each other, and floating about as discrete particles in the solvent. An increase in viscosity with time would signify either an increase in the size (length) of the threads or an increased degree of hydration. At elevated temperatures the equilibrium is evidently rapidly attained. This seems to be due to the relatively small changes that are induced in the particle size and degree of hydration by variations in temperature *at elevated temperatures*, and to the high mobility of the free solvent. But as the temperature falls the amount of change per unit drop in temperature rapidly increases, and with this a rapid decrease in the mobility of the solution through the rapid withdrawal of the solvent by hydration. The time required for the colloidal molecule-fibrils to reach a state of complete equilibrium with the solvent is consequently vastly increased. In other words, the solution will show an increase in viscosity with time.

Under any given condition of temperature and hydrogen ion concentration there will be a definite viscosity which the system will attain at equilibrium. A temperature at which no change in viscosity with time occurs indicates an equilibrium condition, but this temperature will vary with different hydrogen ion concentrations and with different degrees of purity of the sample. It is in no way indicative of a critical temperature between the sol and gel forms, but is rather only a point on a continuous curve. This may be expressed by the equation:

$$\eta_{\text{pH}} = K/f(T),$$

where  $\eta_{\text{pH}}$  is the viscosity at equilibrium at any given pH,  $f(T)$  is some function of the temperature, and  $K$  is a constant. On account of the length of time required to attain equilibrium, and the difficulty of eliminating completely all other influences, as hydrolysis due to the prolonged action of water, electrolytes, or bacteria, the exact measurement of  $\eta_{\text{pH}}$  is uncertain, except

where the conditions have been met for the existence of an equilibrium immediately. This is the condition encountered where that temperature is obtained at which no change in viscosity with time is observed.

The author<sup>1</sup> has shown that the gel consistency is proportional to the undegraded protein present in a gelatin or glue. It follows, therefore, that the undegraded gelatin possesses a much larger water-absorbing capacity than the proteoses or peptones. It was also early pointed out<sup>2</sup> that the viscosity varied with the size of the colloid aggregate in the solution. The present theory demands that viscosity vary with the degree of hydration (measured by the rigidity of the gel) and with the size (length) of the colloid fibril (measured by the elasticity of the gel<sup>3</sup>). This is only an amplification of the earlier findings. The "melting point" was shown<sup>4</sup> to be determined by the protein content and was found to give a "grading" lying between that resulting from measurements of gel strength, and of viscosity at high temperatures (60°C.). Since it has been shown that "melting point" is in reality only a transitional period between the sol and gel forms, and that the transition involves only an increase in degree of hydration and a lengthening in the colloid molecule-threads, it must also follow that any measure of "melting point" will indicate a resultant between the effects of hydration and of length of thread, or, differently expressed, a resultant between gel strength and viscosity at high temperatures, which is exactly in conformance with the data reported in an early paper.

The conclusions of Fischer<sup>5</sup> state, "the phenomena of hydration (swelling) and of 'solution' while frequently associated are essentially different. Hydration is to be regarded as a change through which the protein enters into physicochemical combination with its solvent (water); 'solution,' as one which can be most easily understood at the present time as the expression of an increase in the degree of dispersion of the colloid." This is in satisfactory agreement with the ideas expressed above, for although we do not consider that a true solution may exist at low temperatures on

<sup>1</sup> R. H. BOGUE, *Chem. Met. Eng.*, **23** (1920), 105.

<sup>2</sup> *Idem.*, 108.

<sup>3</sup> See Apparatus of S. E. SHEPPARD, *J. Ind. Eng. Chem.*, **12** (1920), 1007.

<sup>4</sup> R. H. BOGUE, *loc. cit.*, 64.

<sup>5</sup> MARTIN FISCHER and W. D. COFFMAN, *J. Am. Chem. Soc.*, **40** (1918), 304; MARTIN FISCHER, "Soaps and Proteins," New York (1921), 219.

account of the heavy hydration, yet the change in a jelly upon conversion to a liquid involves a disintegration of the colloid aggregates (increase in degree of dispersion) as well as a lessening in the degree of hydration.

*Specific Influence of Electrolytes.*—The specific effects of electrolytes upon the sol-gel equilibrium were studied in a special

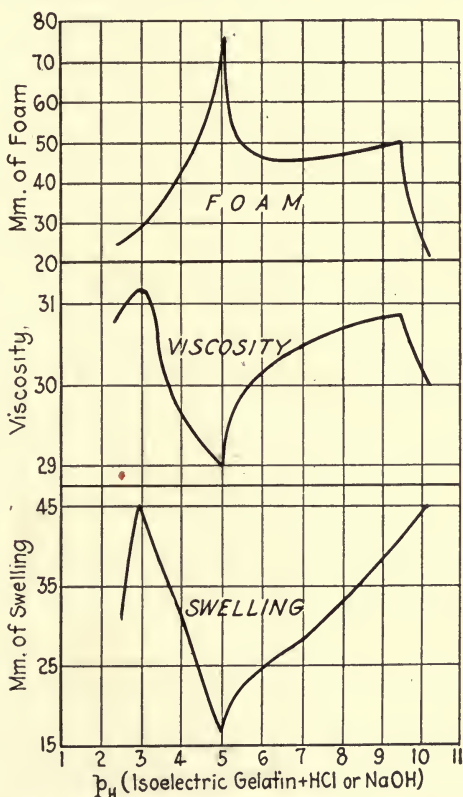

FIG. 17.—Influence of hydrogen ion concentration on the swelling, viscosity and foam of gelatin.

series of experiments.<sup>1</sup> The influence of pH on the swelling, viscosity, jelly consistency, foam, turbidity, and alcohol number was investigated.

It was found that the maximum viscosity and swelling occurred at a pH of 3.5 or 9.0, and the maximum jelly consistency at a pH of 4.0 to 4.5. All of the properties studied, with the exception

<sup>1</sup> R. H. BOGUE, *J. Am. Chem. Soc.*, **44** (1922), 1343.

of turbidity and foam, appear to have their minimum values, and these two properties their maximum values, at or near the isoelectric point. If acid or alcohol are present in excess of the optimum specified, the values of the properties again decline. Phosphoric and lactic acids were found to behave quite similarly to hydrochloric acid, but sulfuric acid produced a diminution in

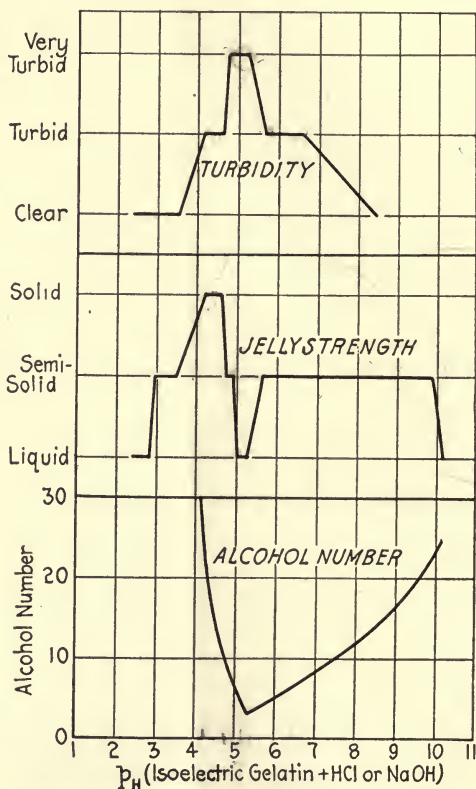

FIG. 18.—Influence of hydrogen ion concentration on the alcohol number, jelly strength, and turbidity of gelatin.

the swelling and viscosity. These results are all similar to those reported by Loeb, and will be discussed more fully in Chap. V. Curves of some of the data obtained are shown in Figs. 17 and 18. The data are found to furnish additional evidence in favor of the sol-gel equilibrium that has been described. The swelling may be taken as a measure of the hydration and this is found to be parallel to the viscosity. Any increase in viscosity must be



accountable to an increase in the effective volume of the gelatin in the solution. This volume is obviously at a minimum at the isoelectric point which signifies that hydration is least at that particular pH.<sup>1</sup> This seems to be due to the fact that at that hydrogen ion concentration gelatin is unionized, and ions appear to be capable of greater hydration than unionized molecules.<sup>2</sup> The viscosity of isoelectric gelatin increases upon standing, however, at a greater rate than at any other pH, and this appears to be due to the very marked insolubility of the gelatin at that pH, for the tendency of the gelatin molecules and colloid fibrils to increase in size (length) is so decided that it is easily observable under the ultramicroscope. It is especially significant to observe that the jelly consistency of isoelectric gelatin (see curves) becomes very low at that pH which also indicates a low degree of hydration.

The increases in viscosity observed by raising or lowering the pH from the isoelectric point are probably attributable to a variation in degree of hydration, as shown by the parallelism of the viscosity and swelling curves. The sudden drop in both viscosity and swelling at pH above 9 or below 3 seems to be due to a "solution" or breaking down of the colloid molecule-threads, and this disintegration is accompanied by a corresponding lessening in the ability of the smaller aggregates or molecules to take up water. That this reasoning is correct is further evidenced by the known inability of the proteoses and peptones to absorb water to anything like the degree attained by the gelatin aggregates.

The depressing influence of inorganic ions on the swelling and viscosity of the gelatin is partly attributable to the withdrawal of water from the swollen gelatin by these ions. And since the high viscosities are due to the heavily swollen gelatin aggregates, any decrease in the degree of such hydration must be reflected by a drop in the viscosity of the solution. Divalent ions appear to be capable of greater hydration than monovalent ions and should therefore be expected to be capable of withdraw-

<sup>1</sup> That the presence or absence of ions is responsible for swelling, etc. is denied by Fischer. He believes (personal communication) that the polymerized amino-acid (isoelectric gelatin) has a lower hydration capacity than the ordinary salts of the acid (gelatin salts and gelatinates). That is, the free acid is simply a poorer solvent for the water.

<sup>2</sup> H. C. JONES, *Am. Chem. J.*, **34** (1905), 291.

ing larger amounts of water from the gelatin particles. From the experiments of Fischer,<sup>1</sup> it is also shown that divalent base (soaps and) proteinate dissolve less water than monovalent ones.

The turbidity curves indicate that the greatest opacity results from the largest aggregates of least swollen particles. This maximum of opacity occurs at the isoelectric point. Any decrease in the size of the aggregates or increase in the hydration results in greater clarity or transparency of the solution.

The foaming qualities appear to be influenced in a similar manner to the turbidity, the maximum of foam being obtained at the isoelectric point. This is exactly what would be expected for, since the foam consists of bubbles of air retained by a continuous film, only molecules that have a strong tendency to adhere to each other would be efficacious in film formation. At the isoelectric point gelatin molecules show their maximum tendency to form large aggregates.

The alcohol number is at its minimum value near the isoelectric point, and rises rapidly to infinity on the acid side and somewhat less rapidly on the alkaline side. Since the alcohol number refers to the precipitability of gelatin by alcohol it would be expected that the larger the molecular aggregate, and the less the water content of the aggregate, the more readily would such precipitation be brought about. This is especially significant in that alcoholic precipitation of proteins probably consists essentially of a dehydration, or extraction of water. Therefore in such solutions in which dehydration is already high and there is but little tendency towards hydration, the completion of the reaction is readily brought about by alcohol, but in systems that are heavily hydrated, the dehydrating influence of added alcohol may be insufficient to effect precipitation.

*Mutarotation.*—The data of C. R. Smith<sup>2</sup> on mutarotation have been examined critically in their applications to the sol-gel equilibrium. The change in specific rotation, or mutarotation, of gelatin solutions of a constant concentration upon reduction of the temperature from 35 to 15°C. was found to drop off very markedly with a decreasing jelly consistency of the gelatin or glue employed. That is, the mutarotation was highest in a (3 per cent) solution of a gelatin which was capable of gelling (at 15°C.) at a concentration of about 0.56 per cent, and very

<sup>1</sup> MARTIN FISCHER, *lib. cit.*, p. 14.

<sup>2</sup> C. R. SMITH, *J. Ind. Eng. Chem.*, **12** (1920), 878.

low in a (3 per cent) solution of gelatin which would gel (at 15°C.) only when the concentration had been raised to 2.00 per cent or higher. To have a more concise picture of the exact relations the data of Smith have been plotted, the ordinate representing the mutarotation, (15° - 35°) and the abscissa the minimum amount of gelatin required to produce a standard jelly at 15°. This curve is shown in Fig. 97. (See page 413.)

There are many minor discrepancies observable, but these are attributable to the failure of the method employed for measuring jelly consistency<sup>1</sup> to distinguish between rigidity (hydration) and elasticity (length of colloid fibril). The general tendency of the curve is, however, incontrovertable.

Since the jelling power of a gelatin solution has been shown<sup>2</sup> to be proportional to the content of unhydrolyzed protein present, it follows that the mutarotation is also proportional to the protein content. But the specific rotation at elevated temperatures (above 35°C.) does not vary with jelly consistency. The specific rotation at low temperatures (below 15°C.) does however increase (negatively) with increasing power of jelly formation. We have given\* evidence which indicates that the proteins (gelatin) are capable of vastly greater hydration than the proteoses and peptones. It appears, therefore, necessary to conclude that the increase in mutarotation, or in specific rotation upon reduction in temperature (35° to 15°C.) must be dependent for its existence upon the greatly increased hydration which such unhydrolyzed proteins are found to undergo upon similar reductions in temperature.

*The Occlusion Theory.*—Loeb<sup>3</sup> has recently questioned the whole conception of hydration in the older sense in which the term was used by Pauli, at least in so far as it applies to solutions of the proteins (gelatin, casein and crystalline egg albumin), and finds it impossible to reconcile the results of his experiments upon the viscosity and osmotic pressure of such solutions with the early hydration theory.

To study the question Loeb performed a long series of experiments with solutions and suspensions of gelatin. He found that the influence of electrolytes on the viscosity of *suspensions* of

<sup>1</sup> A standard viscosity which would permit a bubble of air to rise through a tube of the gelatin sol-gel at an arbitrarily selected rate.

<sup>2</sup> R. H. BOGUE, *loc. cit.*

<sup>3</sup> JACQUES LOEB, *J. Gen. Physiol.*, **3** (1921), 827; **4** (1921), 73; 97.



powdered particles of gelatin in water was similar to their influence on the viscosity of *solutions* of the gelatin in water. He found it unnecessary to assume that the high viscosity of proteins is due to the existence of a different type of viscosity from that existing in crystalloids, but that such high viscosities could be accounted for quantitatively and mathematically on the assumption that the *relative volume* of the gelatin in solution is comparatively high. And since isoelectric gelatin is not ionized, the large volume cannot be due to an hydration of gelatin ions. Loeb therefore postulates that the high volume of gelatin solutions is caused by the existence in the solution of "submicroscopic pieces of solid gelatin occluding water, the relative quantity of which is regulated by the Donnan equilibrium." This view was supported by experiments on solutions and suspensions of casein chloride and gelatin chloride in which it was shown that viscosity was due chiefly to the swelling of solid particles, occluding quantities of water regulated by the Donnan equilibrium, and that the breaking up of these solid particles into smaller particles, no longer capable of swelling, diminished the viscosity.

The idea is advanced that proteins form true solutions in water which in certain instances contain, side by side with isolated ions and molecules, submicroscopic solid particles capable of occluding water whereby the relative volume and the viscosity of the solution is considerably increased. This seems to account for the high order of magnitude of the viscosity of such protein solutions, and also for the similarity of the influence of electrolytes upon the viscosity and the swelling of protein particles. That type of viscosity which is due to the isolated ions and molecules is of a low order of magnitude, as that of crystalloids in solution, and this seems to predominate in solutions of crystalline egg albumin and in metal caseinates, while that viscosity which is due to the submicroscopic solid particles is very high, and predominates in solutions of gelatin and acid salts of casein.

The typical influence of electrolytes on the osmotic pressure of protein solutions is explained as due to the isolated protein ions, since these alone are capable of causing a Donnan equilibrium across a membrane impermeable to the protein ions but permeable to crystalloid ions. The effect of electrolytes on the viscosity of protein solutions is, on the other hand, due to the submicroscopic solid particles with their occluded water, for the



amount of water occluded by them (the swelling) is also regulated by the Donnan equilibrium.

Substances such as glycine or crystalline egg albumin should not be expected to show variations in degree of hydration with changes in pH of a nature parallel to those variations in hydration resulting from similar changes in pH of gelatin solutions. The author<sup>1</sup> has already shown many differences in fundamental properties between true gelatin, proteose and peptone. Thus the swelling, viscosity, and power of gelation vary directly as the gelatin content (of a commercial gelatin or glue), and the size of the gelatin aggregate, and further evidence<sup>2</sup> has been given that these variables are controlled to a large extent by the degree of hydration or imbibition.

In order to understand the importance which Loeb attaches to his argument against the hydration theory, it is necessary to emphasize that the term *hydration* was used in a very specific sense. By it Loeb referred exclusively to the hydration concept postulated by Kohlrausch and extended by Pauli.<sup>3</sup> According to this conception each individual protein ion is surrounded by an enormous shell of water molecules, while the non-ionized molecule of protein has no or little of such a shell. If this theory were correct, the variations in swelling, viscosity, osmotic pressure, etc., should follow the variations in degree of ionization of the protein. But Loeb has shown by conductivity measurements that this is not the case.

The sense in which the term *hydration* has been used by the author is that adopted by Wo. Ostwald and Martin Fischer to signify only the taking up of water by the protein ions, molecules, or particles, and without any necessary implication upon the mechanism of such combination. The study on the sol-gel equilibrium outlined above has concerned itself with an explanation of certain characteristic phenomena which has necessitated the postulation of hydration in the above sense. Loeb has however confined his argument for the most part to a consideration of the intermolecular mechanism by which such combinations with water may be most satisfactorily accounted for. The two points of view are in no sense contradictory.

<sup>1</sup> R. H. BOGUE, *loc. cit.*, 105.

<sup>2</sup> R. H. BOGUE, *J. Am. Chem. Soc.*, **43** (1921), 1764; *J. Ind. Eng. Chem.*, **14** (1922), 32.

<sup>3</sup> Personal communication from Jacques Loeb.

## CHAPTER IV

### GELATIN AS A LYOPHILIC COLLOID

Since the birth of the classical physical chemistry of molecular solutions no branch of physics or chemistry has arisen which can be compared in importance with that of colloid chemistry. Wo. Ostwald. (1917).

	PAGE
1. The Colloid Conception.....	160
2. The Swelling, Solution, and Gelation of Gelatin.....	164
Physical Equilibria.....	164
Osmotic Phenomena in Swelling.....	171
Chemical Phenomena in Swelling.....	173
Influence of Salts upon Swelling and Solution.....	182
3. The Viscosity of Gelatin.....	186
General Considerations.....	186
Conditions Affecting Viscosity.....	187
The Theories of Viscosity.....	200
The Viscosity-Plasticity Relationship.....	207
4. The Theory of Emulsions.....	212

#### I. THE COLLOID CONCEPTION

The conception of the term *colloid* was first introduced into scientific literature by Thomas Graham<sup>1</sup> in 1861. This illustrious English chemist first pointed out that while ordinary (inorganic) salts (in solution) would pass easily through parchment or animal membranes, many organic compounds refused to do so.

As the substances which dialyzed through were quite generally of the crystallizable type, and those which were retained were not crystallizable, he called the former crystalloids, and the latter colloids, from *colla*, meaning glue. Although this distinction was held to obtain for many years, yet today a somewhat different conception of the terms is understood. Some substances which are not crystallizable, are found to pass through certain membranes, and, on the other hand, many substances which do not dialyze have been in recent years prepared in the crystalline state. Again, it was long believed that the property of dialysis was characteristic of the composition of the particular

<sup>1</sup> THOMAS GRAHAM, *Trans. Roy. Soc. London*, 1861-1864.

substance, but the classical researches of von Weimarn,<sup>1</sup> and Wo. Ostwald<sup>2</sup> have demonstrated that as a matter of fact nearly every substance may be prepared in the colloid state. Ostwald and von Weimarn regard the colloid condition as a universal state of matter. Even such a simple inorganic crystalloid as sodium chloride may easily be obtained in a colloid condition.

Zsigmondy<sup>3</sup> has shown that nearly all solutions which exhibit the characteristic properties of colloids, such as non-diffusibility, non-dialyzability, high viscosity, etc., also reveal under the ultramicroscope the presence of a large number of particles that are too small to be seen by the ordinary microscope, but yet are vastly larger than the ordinary molecules. These he called *amicros*. As soon as the particles become microscopic in size, the "solution" exhibits the properties of an ordinary suspension or emulsion, the particles gradually settle out, and the typical colloid characteristics are lost. Likewise, when the particles attain molecular dimensions, the solution again loses the special properties by virtue of which it has been classified as colloidal.

The question naturally arises: why should a solution in which are dispersed particles of a size between molecular and microscopic exhibit properties so vastly different than other solutions? The explanation lies probably in the surface energies involved. For example, one solid cubic centimeter has a total surface of 6 sq. cm. If this is subdivided into cubic millimeters the number of cubes will be 1,000, and the total surface will be 60 sq. cm. On repeating the process, if the length of an edge of the cube is made one micron ( $\frac{1}{1,000}$  mm., or  $1\mu$ ) the number of cubes is increased to  $10^{12}$  (one trillion), and the total surface is 6 sq. m. A length of edge of a milli-micron ( $\frac{1}{1,000}$  micron or  $1\mu\mu$ ) results in  $10^{21}$  cubes, and a total surface of 6,000 sq. m.

It is well known that the surface of bodies, even of ordinary dimensions, exhibits many properties and peculiarities which are not observed at interior points. Surface condensation, surface potential, surface tension, and the like are common manifestations with which we are familiar. It is not unreasonable therefore to expect that where the surface is increased to such vast

<sup>1</sup> VON WEIMARN, "Grundzuge der Dispersoidchemie," Dresden (1911).

<sup>2</sup> WO. OSTWALD—FISCHER, "A Handbook of Colloid Chemistry," Philadelphia (1919).

<sup>3</sup> ZSIGMONDY—SPEAR, "The Chemistry of Colloids," New York (1917).

proportions as obtains in colloidal solutions, the properties of such systems should also be fundamentally different.

The actual size of particle which has been found to be characteristic of the colloid state has been stated by Wo. Ostwald<sup>1</sup> to lie between 1 and 100 $\mu\mu$ . He classifies dispersed systems according to the following scheme:

DISPERSED SYSTEMS

Coarse dispersions	Colloids	Molecular dispersoids
Greater than 100 $\mu\mu$ in size. Do not pass through filter paper. Microscopically analyzable.	100 to 1.0 $\mu\mu$ in size. Pass through filter paper. Cannot be analyzed microscopically. Generally observed in ultramicroscope. Do not diffuse or dialyze.	Less than 1.0 $\mu\mu$ in size. Pass through filter paper. Cannot be analyzed microscopically, nor observed in ultramicroscope. Diffuse and dialyze.

A colloidal dispersion of a substance (the *dispersed phase*) in a liquid (the *dispersion medium*) which appears like a homogeneous solution, but has the properties of a colloid, was called by Graham a colloid *sol*. He gave the name *gel* to the dispersion which was obtained from a sol by so changing the *degree of dispersion*, *i.e.*, the size of the dispersed particles, that a precipitation or coagulation resulted. For example, on adding a salt solution to an arsenic sulphide sol, an immediate precipitation of ordinary arsenic sulphide took place, and this substance he referred to as the gel. A similar addition to a sodium silicate sol resulted in the gelatinization of the material, and this jelly was also known as a gel. There is still some difference of opinion as to whether the term *gel* should be applied to the jelly resulting from the gelatinization of reversible colloids, such as gelatin, which is brought about, for example, by cooling a gelatin sol. The tendency however is to apply the term to both cases, and it is so used throughout this book.

Gelatin water systems are spoken of as *reversible colloid systems* because they may be repeatedly changed from the sol to the gel state, and *vice versa*, by merely changing the temperature or

<sup>1</sup> Wo. OSTWALD—FISCHER, "Theoretical and Applied Colloid Chemistry," N. Y. (1917), 20.



other agency which brought about the change. An *irreversible colloid system* may not be brought back to its original condition by any ordinary reversal of environment.

A further subdivision of colloid systems is made depending upon the physical state of the particles which constitute the dispersed phase. If these consist of liquid particles dispersed in a liquid, Wo. Ostwald<sup>1</sup> has applied the term *emulsoid*, while if the dispersed phase consists of solid particles, likewise dispersed in a liquid medium, the term *suspensoid* is used. Many other designations have been given to these two distinctly different types of colloids. Henri<sup>2</sup> speaks of the emulsoid type as *stable* and the suspensoid type as *instable*, on account of the ease with which the latter type is precipitated with electrolytes. A. A. Noyes<sup>3</sup> calls them *colloidal solutions* and *colloidal suspensions* respectively. Perrin<sup>4</sup> first used the terms *hydrophilic* and *hydrophobic*, which have been largely substituted by the more expressive terms *lyophilic* and *lyophobic*, suggested by Freundlich and Neumann.<sup>5</sup> The lyophilic colloids are, according to Noyes, "viscous, gelatinizing, colloidal mixtures, not (easily) coagulated by salts," and the lyophobic colloids as "non-gelatinizing, but easily coagulable mixtures." Martin Fischer<sup>6</sup> carries the distinction further. He considers that "a suspension colloid (hydrophobic or lyophobic) results whenever the colloiddally dispersed phase is *not* a solvent for the 'dispersing medium'; a hydrophilic or lyophilic colloid whenever the dispersed phase *is* such a solvent (and independently of the fact that the subdivided phase is solid, liquid or gaseous at the temperature employed)." Bancroft<sup>7</sup> has decided that the expressions hydrophilic and hydrophobic became meaningless when the original distinction between the suspensoid and emulsoid colloids was lost, and in characteristic Bancroft style remarks that "it seems foolish to invent new words when we have two perfectly good ones with no meanings attached to them," and suggests "that hydrophile be used to designate colloidal solutions in water, and hydrophobe for colloidal solutions in non-aqueous solutions."

<sup>1</sup> WO. OSTWALD, *op. cit.*

<sup>2</sup> HENRI, *Z. physik. Chem.*, **51** (1905), 29.

<sup>3</sup> A. A. NOYES, *J. Am. Chem. Soc.*, **27** (1905), 85.

<sup>4</sup> PERRIN, *J. Phys. Chem.*, **3** (1905), 50.

<sup>5</sup> FREUNDLICH and NEUMANN, *Kolloid-Z.*, **3** (1908), 80.

<sup>6</sup> MARTIN FISCHER, *Science*, N. S., **49** (1919), 615.

<sup>7</sup> W. D. BANCROFT, *J. Phys. Chem.*, **19** (1915), 275.

## 2. THE SWELLING, SOLUTION, AND GELATION OF GELATIN

**Physical Equilibria.**—When gelatin is allowed to remain in cold water it takes up many times its original volume of the water, becomes rubbery and jelly-like, but rigidly retains its shape, and only traces of the gelatin pass into solution. The presence of electrolytes in the solution greatly modifies the amount of water which will be imbibed by the gelatin, some increasing, others lessening the degree of swelling. On warming the swollen gelatin and water the amount of gelatin entering solution increases but very slightly until a particular temperature is reached at which the mass loses its rigidity of form and enters into an apparently homogeneous phase with the solvent. This temperature is commonly known as the *melting point* of the jelly.

*Volume, Pressure, and Heat Effects of Swelling.*—The mechanism of this rather remarkable property of swelling; the fundamental processes underlying and involved in the phenomenon; and the many conditions affecting the process, have been the subject of a large number of investigations. As far back as 1870 Quincke<sup>1</sup> showed that the swelling of gelatin was not an altogether simple absorption, for he observed that the process involved a volume contraction. The volume of the swollen jelly was not as great as the sum of the volumes of the unswollen gelatin and the water taken up.

Hatschek<sup>2</sup> has described an experiment which strikingly demonstrates this volume contraction. One gram of gelatin is placed in a pycnometer, the latter then filled with water and weighed. It is placed in water, left until the gelatin has become fully swollen, then taken out and again weighed. The increase in weight represents directly the amount of contraction of the original system: *e.g.*, the amount of water that has entered the pycnometer owing to the contraction of the gelatin plus imbibed water. In one experiment Hatschek found a volume contraction of nearly 2 per cent of the original volume. If the same effect were to be obtained by mechanical compression of the water, a pressure of about 400 atmospheres would be required.

Since the compression of a liquid involves the liberation of heat, it becomes obvious that the swelling of gelatin must be, *a priori*, an exothermic process. That heat is indeed liberated was first shown by Wiedemann and Lüdeking<sup>3</sup> in 1885 who

<sup>1</sup> QUINCKE, *Arch. Ges. Physiol.*, **3** (1870), 332.

<sup>2</sup> E. HATSCHKE, "An Introduction to the Physics and Chemistry of Colloids," London (1913), 55.

<sup>3</sup> WIEDEMANN and LÜDEKING, *Ann. Physik. Chem.*, **25** (1885), 145.

reported the following amount of heat in gram-calories liberated per gram of substance:

TABLE 34.—LIBERATION OF HEAT ON THE SWELLING OF GELS

Gel	Gram-calories per gram of gel
Gelatin.....	5.7
Starch.....	6.6
Gum arabic.....	9.0
Gum tragacanth.....	10.3

Further evidence that the swelling of gels is more than the mere taking up of water within the pores or around the molecules, as a sponge takes up water, is shown very strikingly in an experiment by Reinke.<sup>1</sup> He confined circular disks of the foliage of *Laminaria*, a seaweed, in a cylinder, and placed above this a weighted piston containing numerous small perforations through which the water reached the gel. The following table shows the pressure on the piston in atmospheres (kg. per sq. cm.) and the accompanying increase in volume of the gel at that pressure. Data obtained by Posnjak<sup>2</sup> are included in the second portion of the table.

TABLE 35.—EFFECT OF PRESSURE ON THE SWELLING OF GELS

Pressure in atm.	Percentage increase in volume	Pressure in cm. mercury	Grams water per gram gelatin
41.2	16	38.3	2.56
31.2	23	82.4	2.06
21.2	35	156.0	1.46
11.2	89	240.0	1.28
7.2	97	303.0	1.10
3.2	205	377.0	0.92
1.2	318		
1.0	330		

<sup>1</sup> Described by HATSCHEK, *lib. cit.*, 56.

<sup>2</sup> E. POSNIAK, *Kolloidchem. Beihefte*, **3** (1911), 417.

That the gel increases in volume 330 per cent at atmospheric pressure seems remarkable, but much more extraordinary is the observation that even at the high pressure of over 41 atmospheres the gel still absorbed water to produce an increase in volume of 16 per cent. This makes it clear that a swollen jelly, unlike a sponge, may not be made to give up its imbibed water by moderate pressure alone.

*Velocity of Swelling.*—The time relations of swelling phenomena were early studied by Hofmeister.<sup>1</sup> He found that the maximum velocity of swelling was attained immediately on immersion of the gel, and decreased regularly as swelling proceeded. This action is in effect an application of the law of mass action of Guldberg and Waage.<sup>2</sup> In order to express the facts mathematically Hofmeister developed the following equation:

$$W = P \left( 1 - \frac{1}{1 + \frac{c}{d} t} \right),$$

in which  $W$  is the weight of water absorbed by unit weight of gel in time  $t$ ,  $P$  is the maximum amount of water which the unit weight of gel will imbibe,  $c$  is a constant, and  $d$  is the thickness in millimeters of the plate at its maximal degree of swelling. Thus the greater the value of  $P$ , the greater the velocity of the swelling at any moment.

An investigation conducted by Pauli<sup>3</sup> led him to the adoption of a slightly different formula. He found evidence that the swelling of a given particle was dependent, not only on the free water present, but was also influenced by the water content of each neighboring particle. He wrote the equation:

$$K = \frac{1}{t - t_1} \log \frac{M - Q}{M - Q_1},$$

in which  $K$  is a constant which varies inversely with the thickness of the plate,  $Q$  is the quantity of water taken up by unit weight of gelatin in time  $t$ ,  $Q_1$  the quantity of water taken up by unit weight of gelatin in time  $t_1$ , and  $M$  is the maximal degree of swelling attained. This equation expresses the velocity of

<sup>1</sup> HOFMEISTER, *Arch. exptl. Path. Pharm.*, **27** (1890), 395; **28** (1891), 210.

<sup>2</sup> Cf. NERNST, "Theoretical Chemistry," 6th ed., London (1911), 445.

<sup>3</sup> PAULI, *Arch. exptl. Path. Pharm.*, **36** (1895), 100; **57** (1897), 219; **71** (1898), 333.



swelling as directly proportional at any instant to the swelling which it must yet undergo to obtain its maximum. Hofmeister's formula considers the velocity of swelling at any moment as proportional to the square of the swelling which it has yet to undergo.

Hofmeister further found that after the attainment of the maximum swelling the outer layers of the gelatin passed slowly into solution, and the more readily the larger the amount of acid or alkali present in the watery solvent.

*Equilibrium between the Liquid and Vapor Phases.*—von Schroeder<sup>1</sup> has reported that gelatin in equilibrium with saturated water vapor will still take up large amounts of water and become much more highly distended if placed in liquid water at the same temperature. He found a plate of gelatin weighing 0.904 grams to absorb only 0.37 g. of water upon remaining in an atmosphere of saturated water vapor for eight days, at the end of which time the weight remained constant. But on placing the plate in water at the same temperature 5.63 g. of water were further absorbed in one hour. Conversely, gelatin that has been brought into equilibrium with liquid water was found to give up water when transferred to an atmosphere of saturated vapor.

Wolf and Buchner<sup>2</sup> repeated the investigation and took especial care upon the elimination of possible fluctuations in temperature. They employed vessels silvered on their internal surfaces, and a thermostat of high reliability. It was found possible by them to transfer gelatin in equilibrium with liquid water into the saturated vapor phase without a subsequent loss in weight occurring. But upon even the slightest fluctuation in temperature within the apparatus, loss in weight of the swollen gel took place. But it was observed that an entirely similar loss in weight occurred from open dishes of pure water placed beside the gelatin. The explanation advanced was that a distillation of the water from the gelatin or dishes of water on to the walls of the containing vessel occurred due to a temperature gradient.

Miss Lloyd<sup>3</sup> has pointed out, however, that, in spite of the reliability of the results of Wolff and Buchner, in systems consisting of acid or alkaline gelatin two separate equilibria do actually occur in the fluid and gaseous media, but that the

<sup>1</sup> VON SCHROEDER, *Z. physik. Chem.*, **45** (1903), 74; 109.

<sup>2</sup> WOLFF and BUCHNER, *Z. physik. Chem.*, **89** (1915), 271.

<sup>3</sup> D. J. LLOYD, *Biochem. J.*, **14** (1920), 156.

existence of these two points follows naturally from Donnan's membrane potential theory,<sup>1</sup> and does not, therefore, form an exception to the second law of thermodynamics. Miss Lloyd demonstrated that both the degree and the direction of the change in water absorption of a gelatin gel upon transferring from a liquid to a vapor phase could be controlled by the pH of the solution. That is, it was found possible by a variation in the reaction to determine at will whether a gel should lose weight, gain weight, or remain constant upon being transferred from the liquid to the saturated vapor. At concentrations of N/20 or higher of hydrochloric acid or sodium hydroxide the gel was found to gain in weight. At a concentration of N/200 it lost weight upon being transferred to the saturated vapor, and the loss was at its maximum at this concentration. Upon further decreasing the normality of either acid or base the losses became less, and at the value of water remained practically unchanged. The loss occurring from the alkaline gelatins was much greater (at the same concentrations) than that from the acid gelatins.

Donnan has shown that if a system containing one ion that will not pass through a given membrane be separated by such a membrane from another system all of whose ions are permeative, the concentration of the permeative ions will differ, at equilibrium, on the two sides of the membrane, it being the higher on the side free from the impermeative ion. Miss Lloyd writes the gelatin hydrochloric acid equilibrium, when gelatin chloride is separated from hydrochloric acid by a membrane impermeable to gelatin, but permeable to the other ions:



where  $C_2$  and  $C_3$  represent the concentrations of ionized hydrochloric acid in the jelly and liquid phases respectively, and  $C_1$  the concentration of the gelatin ion. Assuming complete ionization,  $C_3$  must always be greater than  $C_2$ , owing to the electrostatic repulsion between non-diffusible G and diffusible H. If, now, the acid solution of phase II is replaced by saturated water vapor the system becomes unstable, and H and Cl ions must be transferred, together with liquid water, across the membrane. This is sufficient to account for the losses in weight of water observed.

<sup>1</sup> F. DONNAN, *Z. Electrochem.*, **17** (1911), 572. See also page 128.

*The Rate of Solution.*—The temperature of the liquid also has an effect upon the amount of water taken up in a given period of time. Reasoning from the principle enunciated by LeChatelier, inasmuch as the swelling process involves a liberation of heat, the more rapidly the heat produced is carried away, the more rapid will be the process of water absorption. In other words, a low temperature will favor, and a high temperature depress, the rate of water absorption or swelling.<sup>1</sup> It is well known that in order to get glue or gelatin into solution it is very desirable that the substance be first soaked in cold water for several hours, or until it is well swollen, and then warmed. If the glue be put directly into hot water the amount and rate of swelling will be, according to the above theory, greatly decreased, and solution must therefore take place from the outer surface only, instead of from the enormous surface produced by the network of minute capillary spaces which are assumed to exist in the swollen substance.

The conditions governing the rate of solution of crystalloids have been studied by Noyes and Whitney.<sup>2</sup> They find that when no chemical reaction other than a possible formation of "solvates" is involved, the rate of solution in water at any given moment is proportional to the difference between its concentration at that moment and its concentration at saturation. They explain this by supposing that at the crystal-solvent interface there exists a film of the saturated solution, and the thickness of this film is dependent on the rate of stirring of the mixture. Thus the rate with which the constituents of this saturated film diffuse into the outer liquid determines the velocity of solution, or expressed mathematically:

$$\log \frac{a}{a-x} = skt,$$

where  $a$  is the concentration of a saturated solution,  $x$  the concentration of the solution at any moment  $t$ ,  $s$  the area of the surface of the solute, and  $k$  a constant which varies with the rate of diffusibility of the dissolved molecules: *e.g.*, with the rate of stirring and the temperature.

<sup>1</sup> First pointed out by KÖRNER, "Beitrag zur wissenschaftlichen Grundlage der Gerberei," Freiberg (1899).

<sup>2</sup> NOYES and WHITNEY, *Z. physik. Chem.*, **23** (1897), 689.



Robertson<sup>1</sup> concludes from a study of casein that the factor which determines the rate of solution of that protein is the velocity with which it is wetted by the solvent. But a crystal is wetted only on its *external* surface, and this, inasmuch as it takes place instantly, becomes of practically negligible importance in comparison with the rate of diffusion of the dissolved molecules. But proteins contain a multitude of capillary spaces which are not wetted instantaneously, and much time is required for the water to reach every portion of the internal surface. Furthermore diffusion from these capillary spaces of dissolved molecules must be vastly slower than from the external surface. Thus the rate of solution of such a material will be proportional to the rate of penetration of the solvent, and the rate of diffusion of the dissolved molecules from the interior to the exterior of the mass. Robertson and Miyake<sup>2</sup> have shown that solution of casein in alkaline solutions takes place according to the equation:

$$x = Kt^m,$$

in which  $x$  is the amount dissolved in time  $t$ , and  $K$  and  $m$  are constants which vary with the nature and concentration of the alkali and the mass of casein used. Differentiating we obtain:

$$\frac{dx}{dt} = Kmt^{m-1}.$$

The product  $Km$ , termed by Robertson and Miyake the *coefficient of penetration*, expresses the constant proportionality between the velocity of solution and an exponent, characteristic of each solvent, of the time of exposure of the protein to the solvent.

It will be obvious from the foregoing that if a piece of dry gelatin or glue be placed in hot water, swelling will be to a great extent inhibited, and solution will take place from the outer surface only, while if the gelatin be first swollen in cold water, and then placed in hot water, solution will take place from the entire inner as well as outer surface, and therefore be rapid.

The conception of a structure<sup>3</sup> of some kind seems to be

<sup>1</sup> T. B. ROBERTSON, "Physical Chemistry of the Proteins," New York (1918), 286.

<sup>2</sup> ROBERTSON and MIYAKE, *J. Biol. Chem.*, **25** (1916), 351; **26** (1916), 126. *Vide also* ROBERTSON, *ib. cit.*, 280.

<sup>3</sup> *Vide page* 136.



essential to account for the above action. In the dry gelatin the structure exists apparently, but the walls are collapsed one upon another into a rigid and but slightly porous mass. Cold water penetrates these walls and distends the cells, and upon warming, solution takes place from interior as well as exterior. Hot water added directly before swelling could effect solution only by the slow process of dissolving the outermost layers before the underlying ones could be affected.

The degree of swelling which any given gelatin may undergo is dependent upon the previous history of the sample. If the gelatin has been made up in concentration of 10, 20 and 30 per cent and allowed to dry out to a uniform concentration of say 90 per cent, it is found that the most water will be reabsorbed by the sample made from the lowest concentration, and the least by the sample made from the highest concentration of gelatin. If the samples made from the 10 and from the 30 per cent solutions are both allowed to absorb water until their concentration is the same, say 30 per cent, then the two will not act similarly when allowed to remain longer in water, but the former will continue to absorb water rapidly, while the latter will continue but very slowly or not at all. This also is explainable by assuming a structure to develop after the latest warming.<sup>1</sup> A gelatin tends so absorb water to a dilution equal to that which it had at the last warming, but not very much over this.

**Osmotic Phenomena in Swelling.**—It has been definitely established that gelatin exerts a small but appreciable osmotic pressure.<sup>2</sup> A consideration of this fact leads to the conclusion that osmotic forces must play a rôle in the swelling of proteins. The gelatin surface acts as a semipermeable membrane, admitting of the passage of water and, to a somewhat lesser degree, of electrolytes, while depriving any colloid of this prerogative. Thus water and other electrolytic solutions may pass freely into the gelatin complex, but any gelatin which they may dissolve will not only fail to pass out, except at the surface, but will also deprive the imbibed solution of power to again pass into the surrounding solvent. (The laws of osmotic equilibrium are too well known to justify a discussion of them in a book of this nature, but they may be found in any standard work on physical chemistry.<sup>3</sup>)

<sup>1</sup> *Vide* page 141.

<sup>2</sup> *Vide* page 97.

<sup>3</sup> *Cf.* texts on Physical Chemistry by Nernst, Walker, Lewis, etc.

Procter<sup>1</sup> regards the situation somewhat differently by considering a condition of equilibrium to exist only "when the attraction of the water molecules for the gelatin is equal to the sum of the cohesive attraction of the gelatin for itself and the internal attraction of the water outside." In other words, Procter considers that there are three forces involved: (1), an attraction of water molecules for each other; (2), an attraction of gelatin molecules for each other, which he calls the cohesion of the gelatin; and (3), an attraction of water molecules for gelatin molecules. To these should be added a fourth force, *e.g.*, the attraction of gelatin molecules for water molecules. At equilibrium (1) + (2)  $\rightleftharpoons$  (3), and any alteration in the system gelatin-water by which any of these factors would be changed would of course affect the equation in one direction or the other. For example, although the swelling process is exothermic and evolves heat, yet the solution process, on the other hand, is endothermic and absorbs heat, and is therefore favored by higher temperatures. That is, the cohesion of the gelatin molecules decreases, and the attraction of gelatin to water accordingly increases, with rise in temperature. Alcohol however is not a solvent for gelatin: that is, the attraction of alcohol to gelatin is nil, so if gelatin swollen with water were put into alcohol, the sum of the attraction of the water and alcohol and the cohesiveness of the gelatin would be much greater than the mean of the attraction of the water and of the alcohol for the gelatin. The obvious effect would be therefore—from the failure of the alcohol to pass into the gelatin, and the free passage of water out of the same—a contraction of the swollen gelatin.

When any gel is allowed to remain for a number of hours or days, protected against infection with microorganisms, and also against evaporation, a separation into two phases takes place which phenomenon was called by Graham *syneresis*. Wo. Ostwald<sup>2</sup> prefers to regard the swelling process as the reverse of *syneresis*. He points out that during swelling a small amount of the colloid dissolves forming a dilute colloidal solution, while in *syneresis* a small amount of the colloid is excreted into a separate layer forming also a dilute colloidal solution. He

<sup>1</sup> PROCTER, "The Principles of Leather Manufacture," London & N. Y. (1903), 82.

<sup>2</sup> OSTWALD and FISCHER, "Theoretical and Applied Colloid Chemistry," N.Y. (1917), 100.

emphasizes the existence of *structure*, as reported by Bütschli and Quincke, as necessary in order that swelling and syneresis may occur, and argues that swelling consists, firstly, in an *increase in the degree of dispersion* of the gelatin, and, secondly, in a *solva-tion* of the more highly dispersed molecules. Since these two effects tend to influence the volume changes in opposite direc-tions, the equilibrium between them determines the velocity and degree of swelling.

Smith<sup>1</sup> has performed experiments which lead him to believe that the swelling of gelatin is the result of osmotic pressure within the jelly, the jelly acting as an "imperfectly resisting" membrane. He finds that although the osmotic pressure at the optimum concentration of univalent acids and bases is the same, the swelling is, however, much less in alkalis because of the "weakened membrane effect."

**Chemical Phenomena in Swelling.**—Jones and his collabo-rators<sup>2</sup> have accumulated an abundance of data which point to the existence of *solvates* or *hydrates*, of both the ions and the molecules of various substances when in solution. Their theory points to a kind of chemical combination between the elements of water and the ions or molecules in question. There seems to be an equilibrium established between the solvated and non-solvated molecules, and this equilibrium is altered by: (1), the temperature of the solution, and, (2), the presence of other substances which compete for the water. Where proteins are concerned there are several ways in which the elements of water may combine to form the solvated molecules. The water may combine with the terminal —NH<sub>2</sub> or —COOH groups, or with the internal —NHOC— groups, in the latter case resulting in a depolymerization of the molecule. Robertson writes the reactions as follows:<sup>3</sup>

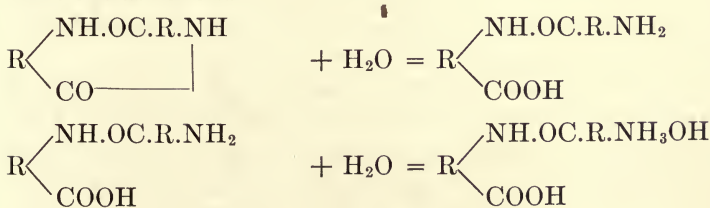

<sup>1</sup> C. R. SMITH, *J. Am. Chem., Soc.*, **43** (1921), 1350.

<sup>2</sup> H. C. JONES and K. OTA, *Am. Chem. J.*, **22** (1899), 5; JONES and UHLER, *ibid.*, **34** (1905), 291; JONES, *Z. physik. Chem.*, **74** (1910), 325.

<sup>3</sup> ROBERTSON, *lib. cit.*, 127.



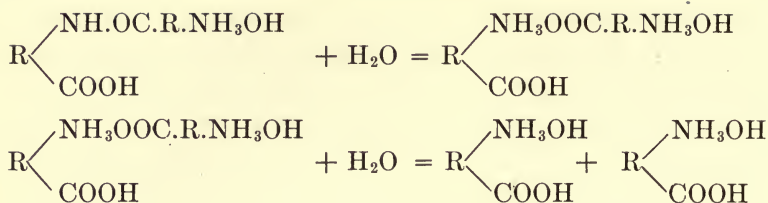

As evidence in favor of the solvate theory Pauli<sup>1</sup> points out that when a protein goes into solution heat is absorbed, while on swelling heat is liberated. He considers the heat evolved on swelling to be the result of the chemical combination of the water and gelatin molecules—the solvation—and the heat absorbed on solution as a purely physical effect.

Probably more work has been done upon the effect of acids and alkalis on the swelling of proteins, than on any other influence attending this phenomenon. Gelatin possesses the very peculiar property of being able to absorb either acids or alkalis from dilute solutions (about tenth normal) to such a degree that the liquid bathing the gelatin may be quite neutral, as far as the litmus test can reveal. The resulting gelatin has moreover acquired the ability to take up a very much larger amount of water than it could do before such treatment. When this effect is subjected to quantitative methods,<sup>2</sup> it is found that very dilute solutions of acids (less than N/256) tend rather to decrease the swelling capacity of gelatin, but from that concentration up to about normal the degree of swelling increases, at first rapidly, but gradually falling off as the latter value is approached. At still higher concentrations the degree of swelling again becomes less. In the presence of alkalis the swelling proceeds regularly from the neutral point until a concentration is reached at which the gelatin dissolves, *i.e.*, about normal at 10°C. Salts in general exert a depressive effect on swelling, but this is determined by the hydrogen ion concentration as will be pointed out later.

The most generally accepted explanation of the influence of electrolytes on swelling phenomena is to be found in the combined effect of osmotic and chemical forces. Hydrochloric acid, for example, has the ability to pass freely into and out of a gelatin gel. So, if gelatin is immersed in a dilute solution of this

<sup>1</sup> PAULI, *Arch. ges. Physiol.*, **57** (1897), 219; **71** (1898), 333.

<sup>2</sup> Cf. especially the curves by Wo. OSTWALD, *Pflüger's Arch. Physiol.*, **108** (1905), 563; and by J. LOEB, *J. Gen. Physiol.*, **3** (1920), 253; 254; 256.



acid, both the ions of the acid and the water will diffuse into the gelatin, and *if no other forces were operative* it would be expected that the concentration of the acid in the water would be the same both inside and outside of the protein. If a gelatin thus swollen with acid were to be placed in pure water, the acid would diffuse out into the water until the acid concentration were again identical in both phases, and upon numerous repetitions of this process, or, which would amount to the same thing, on placing the gelatin in running pure water, all of the acid would eventually have diffused out. This would also apply equally to alkalis.

But it has been shown by numerous investigators<sup>1</sup> that gelatin is an amphoteric colloid, that is, it is capable of combination with either anions or cations depending upon the hydrogen ion concentration of the medium in which it is immersed. For example, in hydrochloric acid solution gelatin chloride will be formed and the gelatin is electropositive, migrating, in an electric field, to the cathode. In a solution of sodium hydroxide, sodium gelatinate will be produced, in which the gelatin is electronegative and, in an electric field, migrates to the anode. At the isoelectric point, that is at the condition of electroneutrality at which the gelatin will not migrate to either electrode, the gelatin exists as a perfectly neutral molecule consisting of free protein, or, in some exceptional cases, of base-protein-acid. It has been shown by Loeb,<sup>2</sup> Michaelis<sup>3</sup> and others that the isoelectric point for gelatin lies at a hydrogen ion concentration of  $C_H = 2.10 \times 10^{-5}$ , or in Sørensen's logarithmic symbol  $pH = 4.7$ . This value, it will be observed, lies upon the acid side of the neutral point of water ( $C_H = 1 \times 10^{-7}$  or  $pH = 7.0$ ). Loeb has furthermore shown that many of the properties of gelatin, as the conductivity, osmotic pressure, swelling, alcohol number, and viscosity, have their minimum value at the isoelectric point and increase on either side of that point with varying degrees of rapidity according to the charge on the ion, etc.<sup>4</sup> Simply expressed, this means that isoelectric gelatin—slightly acid to litmus—will swell the least of any, and that the addition of either acid or alkali, forming gelatin salt or metal gelatinate respectively, will result in an increase in the swelling.

<sup>1</sup> *Vide* Chap. V.

<sup>2</sup> J. LOEB., *J. Gen. Physiol.*, **1** (1918-19), 39; 237; 363; 483; 559.

<sup>3</sup> MICHAELIS, "Die Wasserstoffionenkonzentration," Berlin (1914).

<sup>4</sup> *Vide* Chap. V.

It has already been stated that gelatin immersed in dilute (tenth normal) acid will absorb the acid until the solution surrounding it is nearly neutral. This could not easily be accounted for by osmotic forces alone. It might be argued that the ions of the acid were condensed upon the surface of the gelatin, but the evidence above referred to leaves little doubt that actual chemical combination has taken place. It is true that practically all of the acid may be removed by prolonged dialysis in running water, but this could easily be accounted for by assuming an hydrolytic dissociation of the gelatin salt. Any salt consisting of a combination of strong and weak cation and anion exhibits the property of dissociation into its constituent acid and base, and a gelatin salt may react in a similar manner.

*Procter's Theory of Swelling.*—The quantitative relations of the acid-gelatin equilibrium have been investigated by Procter and his collaborators.<sup>1</sup> They find that the amount of acid "bound" by gelatin at the attainment of maximal swelling is 0.7 to  $0.8 \times 10^{-3}$  equivalents per gram, when the initial concentration of the acid is between 0.01 and 0.25N. They find that this value is practically the same for all strong acids, but becomes smaller as weaker acids are used; and that the concentration of the acid in the surrounding solution has but little influence upon the amount of acid chemically combined. The degree of swelling however increases with increasing concentration up to a certain point, and thereafter decreases. The explanation advanced by Procter assumes the existence of an osmotic pressure *within* the gelatin produced by the imprisonment of chloride ions. He considers that the gelatin will continue to swell until the chloride ions within the gelatin are in osmotic equilibrium with those in the outer solution. Increases in the concentration of the chloride ions in the outer solution will eventually however exert a repressive action upon the ionization and hydrolytic dissociation of the gelatin chloride which will more than offset the tendency to swell due to a larger amount of the gelatin salt being formed, and from that point swelling will decrease, rather than increase, with further additions of acid. In support of this theory Procter recalls that additions of sodium chloride produce decreases in the swelling in a similar way to hydrochloric acid,

<sup>1</sup> PROCTER, *lib. cit.*, 86; *Collegium*, (1915); *Trans. Chem. Soc.*, London, **105** (1914), 313; PROCTER and BURTON, *J. Soc. Chem. Ind.*, **35** (1916), 404; PROCTER and WILSON, *J. Chem. Soc.*, **109** (1916), 307.

and argues that the effect is in accordance to the well known mass law, the excess of chloride ions of the salt having the same influence as those of the acid in repressing ionization and hydrolytic dissociation. Procter affirms that the effect of the salt cannot be a dehydrating action, "since concentrated sodium chloride solutions have no dehydrating, but rather a swelling effect on gelatin in the absence of acid."

Robertson<sup>1</sup> however considers the assumption that the external acid exerts an osmotic pressure as "unnecessary and inconsistent with the fact that the acid freely penetrates the gelatin and combines with it." He regards the action as due to a competition between the inorganic salt and the gelatin salt for water. Since gelatin is readily permeable to the ions of inorganic salts it is difficult to understand a development of osmotic pressure in the system as due to inorganic ions.

Procter has advanced the hypothesis that the anions obtained by ionization of a gelatin salt are held within the mass by electrostatic forces, since they are not able to pass beyond the sphere of attraction of the colloid cations. The latter being of a colloid nature are necessarily held within the gelatin structure. The only way, therefore, in which the osmotic pressure of the anions may become operative is not by their own movement but by the passage of water into the gelatin. Procter points out three objections to this view. If his theory were correct the force requiring movement of water would be the electrostatic tension preventing the escape of anions into the outer solution. This would result in a difference of potential between the internal jelly and the solutions, but Ehrenberg<sup>2</sup> has been unable to detect any such difference in potential. Robertson however regards the colloid particles themselves, rather than the inorganic ions, as responsible for the osmotic pressure, for, since they may not pass the boundary of the gelatin, they necessarily compel the compensating migration of water. "The increased swelling capacity of gelatin in solutions of acids or alkalies is merely the expression of the fact that the ionization of the protein salt leads to an increase in the number of colloid particles per unit volume of the jelly and possibly also in part to the fact that

<sup>1</sup> ROBERTSON, *lib. cit.*, 296.

<sup>2</sup> EHRENBURG, *Biochem. Z.*, **53** (1913), 356. Loeb's experiments on P.D. indicate that Ehrenberg's results are incorrect.



protein ions have a greater affinity for water than undissociated protein molecules."

This much may be considered as established beyond any reason of doubt: the addition of sodium chloride to an acid solution increases the hydrogen-ion concentration of the solution, while the addition of the same salt to an alkaline solution increases the hydroxyl-ion concentration.<sup>1</sup> The author<sup>2</sup> has found that the action of sodium hydroxide is, first, to promote strongly the hydration of the gelatin, which takes place in proportion to the amount of sodium gelatinates produced, and, secondly, to dissolve the gelatin. The latter effect becomes noticeable in concentrations of N/4 sodium hydroxide, and at N/1 the latter effect predominates over the former and solution takes place. There appears to be no reduction in the swelling except that due to solution. Sodium chloride acts in a similar way as regards swelling, but does not result in solution. From an application of the mass law we would expect that an addition of sodium chloride to a solution of sodium hydroxide would increase the sodium ions and depress the hydroxyl ions present. That the reverse actually takes place is due to the hydration of the sodium and chloride ions added. As the liquefaction of gelatin by sodium hydroxide is due to the hydroxyl ions in all probability, it is evident that the amount of hydroxyl ions by which the solution is enriched upon the addition of sodium chloride is still too small to produce that effect.

A second objection to Procter's hypothesis lies in the fact that, according to his theory, no equilibrium would be established, but swelling would proceed indefinitely, which is not the case. Procter considers that the force which opposes an indefinite increase in swelling, and limits the latter to a well defined maximum is the tension of the elastic colloid network. By applying Hooke's law Procter derives the following relation defining the equilibrium:

$$e = C \left( V - \frac{1}{g} \right),$$

in which  $e$  is the tension of the colloid network,  $C$  the modulus of

<sup>1</sup> ARRHENIUS, *Z. physik. Chem.*, **31** (1899), 197; POMA, *ibid.*, **88** (1914), 671; HARMED, *J. Am. Chem. Soc.*, **37** (1915), 2460; FALES and NELSON, *ibid.*, **37** (1915), 2769; THOMAS and BALDWIN, *ibid.*, **41** (1919), 1981; WILSON, *ibid.*, **42** (1920), 715.

<sup>2</sup> R. H. BOGUE, *J. Ind. Eng. Chem.*, **14** (1922), 32.



elasticity,  $V$  the maximum volume attained by one gram of gelatin, and  $g$  the specific gravity of the gelatin. He finds the modulus of elasticity ( $C$ ) decreases with rise in temperature, from 0.00125 at 7°, to 0.00021 at 18°. The value of  $e$  varies as the degree of swelling, at first increasing and later decreasing with continued additions of acid.

*Mathematical Confirmation of Procter's Theory.*—A more extensive mathematical interpretation of these relations is given by J. A. and W. H. Wilson.<sup>1</sup> Starting with a purely hypothetical colloid jelly,  $G$ , they have developed curves which conform in a striking manner to data which were obtained by Procter experimentally. The hypothetical colloid  $G$  is assumed to be completely permeable to water and to all dissolved electrolytes; to be elastic; to follow Hooke's law; and to combine chemically with the positive but not the negative ion of a binary electrolyte  $MN$ , in accordance with the equation:

$$[G] \times [M^+] = K[GM^+]. \quad (1)$$

On immersing  $G$  in an aqueous solution of  $MN$  the solution penetrates  $G$  which thereupon combines with some of the ions  $M^+$ , removing them from solution. The solution within the jelly will consequently have a greater concentration of  $N^-$  than of  $M^+$ , while in the outside solution the concentrations of the ions of the electrolyte must be equal.

In the external solution then, let

$$\begin{aligned} x &= [M^+] = [N^-], \\ y &= [M^+], \end{aligned}$$

and

$$z = [GM^+];$$

whence

$$[N^-] = y + z.$$

Assuming the transfer of an infinitesimally small amount,  $dn$  mols, of  $M^+$  and  $N^-$  from the external solution to the jelly phase, the relation between the concentrations of diffusible ions of the two phases at equilibrium was derived, yielding the equation:

$$dn RT \log x/y + dn RT \log x/(y + z) = 0;$$

whence

$$x^2 = y(y + z). \quad (2)$$

Since the sum of two numbers that are unequal is greater than

<sup>1</sup> J. A. and W. H. WILSON, *J. Am. Chem. Soc.*, **40** (1918), 886.

the sum of two others that are equal but which when multiplied give products identical with the unequal pair, it follows that:

$$2y + z > 2x,$$

for the total concentration of ions  $2y + z$  of the jelly is greater than the ionic concentration  $2x$  of the external solution. Now by letting this excess in the value of  $2y + z$  over that of  $2x$  be represented by  $e$ , the general equation:

$$2x + e = 2y + z, \quad (3)$$

is obtained, which is mathematical proof of the preponderance of the concentration of diffusible ions in the jelly phase over that of the external solution.

Since  $[N^-]$  is greater in the jelly than in the surrounding solution, these ions will tend to diffuse out from the jelly, but electrostatic forces make this impossible except they be accompanied by their colloid cations. The cohesive forces of the elastic jelly tend to resist this outward pull by the value  $e$ , and according to Hooke's law:

$$e = CV, \quad (4)$$

where  $C$  is a constant and  $V$  the increase in volume in cubic centimeters of one millimole of the colloid.

Taking unit quantity of  $G$ :

$$[G] + [GM^+] = 1/(V + a),$$

or

$$[G] = 1/(V + a) - Z, \quad (5)$$

where  $a$  is the free space within the jelly before swelling through which the ions may pass. This will be nearly, but not quite, as great as the initial volume of the colloid. Where  $a = 0$ ,

$$1/(V - Z)y = Kz. \quad (6)$$

From (2) and (3)

$$Z = e + 2\sqrt{ey},$$

or

$$Z = CV + 2\sqrt{CVy}. \quad (7)$$

And from (6) and (7):

$$V(K + y)(CV + 2\sqrt{CVy}) - y = 0. \quad (8)$$

The only variables are  $V$  and  $y$ , and if the constants  $K$  and  $C$  are known the values of either variable may be plotted in terms of the other. Knowing  $y$  and  $V$ , the value of  $Z$  may be calcu-

lated from (7), and knowing  $y$  and  $Z$ , the value of  $x$  may be calculated from (2), and  $e$  from (4).

The values of  $K$  and  $C$  have been calculated by Procter and Wilson.<sup>1</sup>  $K$  was obtained by running successive portions of standard hydrochloric acid into a gelatin solution of known volume, and determining the hydrogen ion concentration by means of the hydrogen electrode after each addition.  $C$  was calculated from values obtained for  $e$  and  $V$ . Their results gave

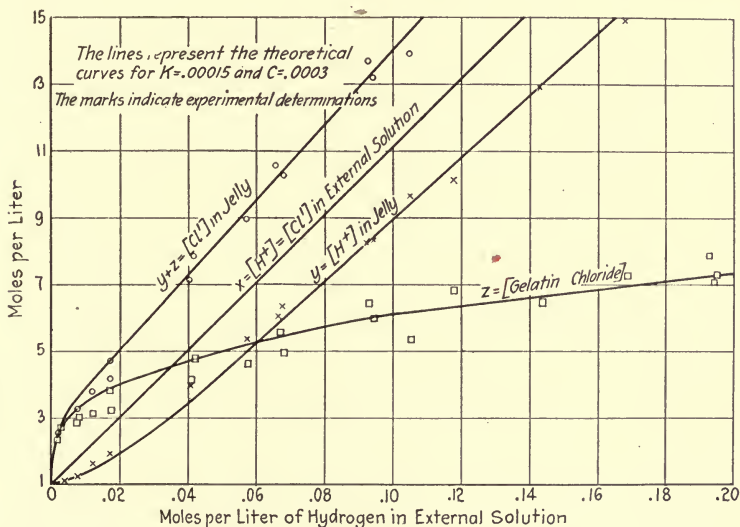

FIG. 19.—Iongenic equilibria in gelatin systems. I. (By permission of the Journal of the American Leather Chemists' Association.)

a value to  $K$  of  $1.5 \times 10^{-4}$  and to  $C$  of  $3 \times 10^{-4}$  at  $18^\circ\text{C}$ . Upon substituting these values in the equations the curves shown in Figs. 19 and 20 are obtained.<sup>2</sup> The ordinates in Fig. 19 indicate the mols per liter of the ions enumerated, and the abscissa the mols per liter of hydrogen ion in the external solution. In Fig. 20 the ordinates are the cubic centimeters of solution absorbed by one millimol of gelatin. The lines in all cases represent the curves derived theoretically from the foregoing mathematical formulæ, while the marks indicate the values obtained by Procter<sup>3</sup> some years earlier. It will be observed

<sup>1</sup> H. R. PROCTER and J. A. WILSON, *J. Chem. Soc.*, **109** (1916), 307.

<sup>2</sup> J. A. WILSON, *J. Am. Leather Chem. Assn.*, **13** (1918), 184-5.

<sup>3</sup> H. R. PROCTER, *J. Chem. Soc.*, **105** (1914), 317.

that the theoretical and experimental findings coincide in a striking manner. In Fig. 20 Wilson assumes the value of 768 as the molecular weight of gelatin, having previously found this value in connection with experiments upon the combining equivalent of gelatin, assuming the latter to act as a monacid base in dilute acid solutions.<sup>1</sup> Procter's values, which were based upon his figure of 839 for the molecular weight of gelatin,<sup>2</sup> assuming the substance to act as a diacid base in dilute acid solutions, were recalculated to the former value. The perfection of the latter

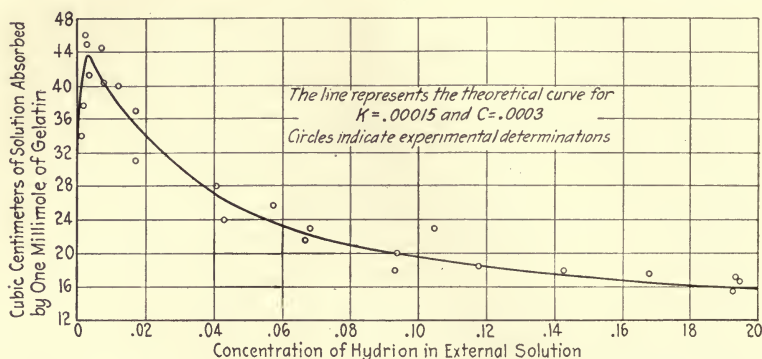

FIG. 20.—Iogenic equilibria in gelatin systems. II. (By permission of the Journal of the American Leather Chemists' Association.)

curve may be urged as proof that the equivalent weight of gelatin is at least of the order of magnitude of 768.

**Influence of Salts upon Swelling and Solution.**—The specific influence of salts upon the swelling and solution of gelatin has been investigated by a number of workers. Loeb<sup>3</sup> has found the valence of the cation or anion with which the gelatin is brought into combination to exert a profound influence. This will be considered in detail in Chapter V.

**Fischer's Theory of Salt Action.**—Fischer and his collaborators<sup>4</sup> have studied not only the effects of simple neutral salts, but also the effects of "buffer" mixtures (phosphates, citrates, and carbonates) upon swelling and solution of gelatin and fibrin. In the phosphate series they added uniformly varying amounts of

<sup>1</sup> J. A. WILSON, *J. Am. Leather Chem. Assn.*, **12** (1914), 317.

<sup>2</sup> H. R. PROCTER, *loc. cit.*, 320.

<sup>3</sup> J. LOEB, *op. cit.*

<sup>4</sup> FISCHER and HOOKER, *J. Am. Chem. Soc.*, **40** (1918), 272; FISCHER and COFFMAN, *ibid.*, **40** (1918); 303; FISCHER, HOOKER, BENZINGER, and COFFMAN, *Science*, N. S., **46** (1917), 189.



phosphoric acid, mono-, di-, and trisodium phosphate and sodium hydroxide to a constant amount of gelatin, and noted the degree of swelling and the effect of the added substances upon the solution of the gelatin. In the citrate series they used citric acid, mono-, di-, and trisodium citrate, and sodium hydroxide.

The data obtained by these investigators show that the curves for swelling and for solution run parallel, the greatest swelling and the earliest signs of liquefaction being brought about in the pure acid or the pure base, while at the point of minimum swelling the gelatin is most insoluble. These investigators conclude, however, that although the same causes may bring about the two phenomena, *e.g.*, swelling and solution, they are nevertheless totally different processes, and liquefaction is not, as has commonly been stated, the extreme of what in lesser degree is called swelling. "Hydration," say Fischer and Coffman, "is to be regarded as a change through which the protein enters into physicochemical combination with its solvent (water); 'solution,' as one which can be most easily understood at the present time as the expression of an increase of the degree of dispersion of the colloid." High temperatures, acids, and alkalis cause the colloid particles to become smaller, and when in this condition the gelatin is liquid and clear, while under the reverse conditions the gels become solid and opalescent. Fischer considers that the warming of a gelatin water system displaces it from the side of a solution of water in gelatin towards that of gelatin in water. In the latter the particles are smaller, more nearly in "true" solution, and therefore the system is also clearer. Neutral gelatin takes up some water but the addition of acid or alkali leads to the formation of gelatin salts and gelatinates which not only have a greater capacity for absorbing water but also a greater solubility in water.<sup>1</sup> If the alkali or acid is added to a neutral gelatin water system near its gelation point the mixtures clear and become liquid because the solubility of the gelatinate or gelatin salt in the water dominates the system. In this region signs of "going into solution" become manifest. Fischer places especial stress upon the relations which these observations bear to physiological and pathological processes, as are observed in edema, excessive turgor, and plasmoptysis, and other "softening" conditions in the tissue.

<sup>1</sup> MARTIN H. FISCHER and MARION HOOKER, *Science*, **48** (1918), 143; MARTIN H. FISCHER, *Science*, **49** (1919), 615.

The exact relations which obtain between the swelling, viscosity, and hydrogen ion concentration have been investigated in the author's laboratory.<sup>1</sup> The results obtained agree well with those of Fischer, but the additional information upon the pH values is even more conclusive in its deductions. It was found that the swelling and viscosity, which are at their minimum at a pH of 4.7, increase regularly with a rise in pH to about 8.5, but that above that value they decline slightly due to an increasing solubility. That is, the hydrogen-ion concentration determines the solvation, and the solvation in turn determines viscosity, swelling, and jelly consistency. When the solvation, which may be defined as the volume occupied by unit weight of dispersed phase, is very small, these other properties will likewise be small; when the solvation is very high then the tendency to go into solution is increased, and the viscosity and jelly consistency are again low. At intermediate degrees of solvation the above properties attain the maximum value.

*Loeb's Theory of Salt Action.*—The relationship between hydrogen ion concentration and solvation, as described, is not at all antagonistic to Loeb's theories of gelatin ionization and salt formation, as some writers have assumed. Without the exact measurements dependent upon the laws of classical chemistry, the colloid chemistry of the proteins becomes a hopeless "slough of despond." Everything is speculative; but little is based upon quantitative evidence. By the masterly efforts of Sørensen, Michaelis, and Loeb we are finding that these great aggregates of molecules called proteins and colloids are susceptible of much the same type of *metamorphosis* as the better understood inorganic substances. But the conception of colloid chemistry as the chemistry of special dimensions need not be laid aside. Special conditions, such as hydrogen ion concentration, that control ionization, conductivity, and osmotic pressure, also control solvation and degree of dispersion.

Donnan<sup>2</sup> in 1911 proposed a theory of membrane equilibrium to account for the differences in osmotic pressure, conductivity, etc., observed between two electrolytic solutions, separated by a membrane, both ions of one of these solutions being permeable in the membrane, and one of the ions of the other solution being

<sup>1</sup> R. H. BOGUE, *J. Ind. Eng. Chem.*, **14** (1922) 32.

<sup>2</sup> F. G. DONNAN, *Z. Electrochem.*, **17** (1911), 572; DONNAN and HARRIS, *J. Chem. Soc.*, **99** (1911), 1554; DONNAN and GARNER, *ibid.*, **115** (1919), 1313.

impermeable. Procter<sup>1</sup> made use of this theory to account for the swelling of gelatin in the presence of inorganic ions. Taking gelatin chloride as an example, placed in a solution containing the ions of a chloride, he defined the swelling as determined by the difference between the concentration of the free ions in the interior of the jelly and the concentration of the free ions in the external solution. He did not attempt to explain the causes for the differences in ion concentration observed, but Loeb<sup>2</sup> has shown that such differences are defined by the hydrogen ion. The potential difference may also be calculated very accurately from the difference of pH inside minus pH outside of the jelly on the basis of Nerst's formula

$$E = \frac{RT}{nF} - \ln \frac{C_1}{C_2},$$

which at room temperature and for  $n = 1$  becomes

$$0.058 \log \frac{C_1}{C_2}.$$

In the experiment the gelatin in 1 per cent solution in sodium nitrate of pH 3.5 was placed in collodion bags and immersed in water containing similar quantities of sodium nitrate, and hydrochloric acid of pH 3.0. If  $C_1$  represents the concentration of free hydrochloric acid in the gelatin solution, and  $C_2$  the concentration of the same in the outside solution, the value  $\log \frac{C_1}{C_2}$  becomes equal to (pH inside - pH outside). The difference in pH multiplied by 58 or 59 (corrected for temperature) would therefore express the potential difference between the inside and outside solutions in millivolts, if Nerst's formula is applicable. By actual measurement the calculated and observed values for potential difference are practically identical. The two solutions are in ionic equilibrium when the one per cent gelatin chloride solution is at pH 3.5 and the external aqueous hydrochloric acid solution is at pH 3.0.

Loeb also made the important observation that the potential difference between the two solutions diminished as the concentration of salt present increased from 0 to M/32. At the latter concentration it had nearly reached zero. He therefore argues that "the depressing influence of salts upon the swelling of gelatin

<sup>1</sup> H. R. PROCTER, *J. Chem. Soc.*, **105** (1914), 313; PROCTER and WILSON, *ibid.*, **109** (1916), 307.

<sup>2</sup> J. LOEB, *J. Gen. Physiol.*, **3** (1921), 557; 667; 691. *Vide* also Chap. V.

is due to a diminution of the difference of pH inside and outside of the gel, and that the curves expressing the influence of neutral salts on the value of pH inside minus pH outside the gel, and on the swelling run approximately parallel."

### 3. THE VISCOSITY OF GELATIN

**General Considerations.**—When crystalloids go into solution the viscosity of the solution is usually slightly greater than that of the pure solvent, and the viscosity of such solutions normally increases with the concentration, but at a somewhat greater rate, so that the curve illustrative of this principle is convex towards the concentration axis. There are some exceptions to this general expression wherein a decrease in viscosity is observed, as the solution of naphthalene in alcohol, or of lithium chloride and potassium chloride in water, which are generally explained as due to a depolymerization of the solvent by virtue of the dielectric effect of the solute.

In the case of suspensoids in dilute solution very slight differences only are observed between their viscosity and the viscosity of the pure dispersion medium. In concentrated solutions of suspensoids however there may be so much solid material in proportion to the liquid present that a paste may result, which is, of course, very viscid.

Both of the above types of dispersion differ quite materially from that which is encountered in the class of colloids of the emulsoid type. In the latter case, we have, according to the viewpoint of Wo. Ostwald, an apparently homogeneous mixture of two immiscible liquids, the one being suspended in very fine droplets throughout the other, *e.g.*, the one discontinuous, and known as the *dispersed phase*, the other continuous, and known as the *dispersion medium*. In this type of colloid solution the viscosity constitutes one of its most striking properties. Even in very dilute solutions *e.g.*, 0.1 per cent, the viscosity is materially higher than that of the dispersion medium, and upon slightly increasing the concentration the viscosity increases enormously. This property, alluded to by Ostwald and others as the internal friction of the emulsoid, is also very variable with slight alterations in the conditions to which it is subjected. These are described below.



**Conditions Affecting Viscosity.**—In the case of molecularly dispersed solutions the viscosity is completely defined by the concentration and temperature. We are dealing with only three variables, and we may plot precise viscosity-temperature curves at constant concentration, or viscosity-concentration curves at constant temperature. In the suspensoids, where the conditions involve a suspension of solid particles in a liquid probably only one further variable enters, *i.e.*, the size of the suspended particle. The greatest viscosity seems to attend a medium degree of dispersion.

But many other factors are found to influence the viscosity of emulsoids. In addition to concentration, temperature, and degree of dispersion, Wo. Ostwald<sup>1</sup> has listed as of importance: solvate formation, electric charge or ionization, the previous thermal treatment, the previous mechanical treatment, inoculation with other colloids, time, and addition of foreign substances. Such an array of variables makes it seem a most difficult if not impossible accomplishment to determine a precise curve for viscosity with any other property, as the effect of all other variables should either be completely eliminated or reduced to a negligible influence. The latter condition may however be approached, and by systematically controlling some of the variables, curves for the others may be obtained which have proved of the greatest service, both in assisting to a more appreciative understanding of the principles underlying changes in state of colloid systems, and in processes of control and analysis in certain instances. The above mentioned factors will be considered in detail in the following paragraphs.<sup>2</sup>

**Concentration.**—If the temperature of a gelatin sol is held constant, and the variation in viscosity due to alteration in the concentration is measured, it will be found that the curve is linear at very low concentrations, but becomes curvilinear at higher concentrations. That is, when the gelatin is present in less than 1 or 2 per cent concentration the increase in viscosity is a linear function of the concentration. As soon, however,

<sup>1</sup> Wo. OSTWALD, *Trans. Faraday Soc.*, **9** (1913), 34.

<sup>2</sup> It should be emphasized that the conclusions which follow were based largely upon experiments in which the pH was not considered. The work of Loeb, Bogue and others, described in the following chapter, and in the section on Structure in Chap. III, makes possible a considerable simplification of the relations.

as the volume occupied by the dispersed phase (which includes the volume of water which is associated with the gelatin molecules in hydrated condition) reaches about 50 per cent of the total volume of the system the viscosity curve will no longer remain linear, but rises ever more and more rapidly with each increase in concentration. This is explained by Hatschek's

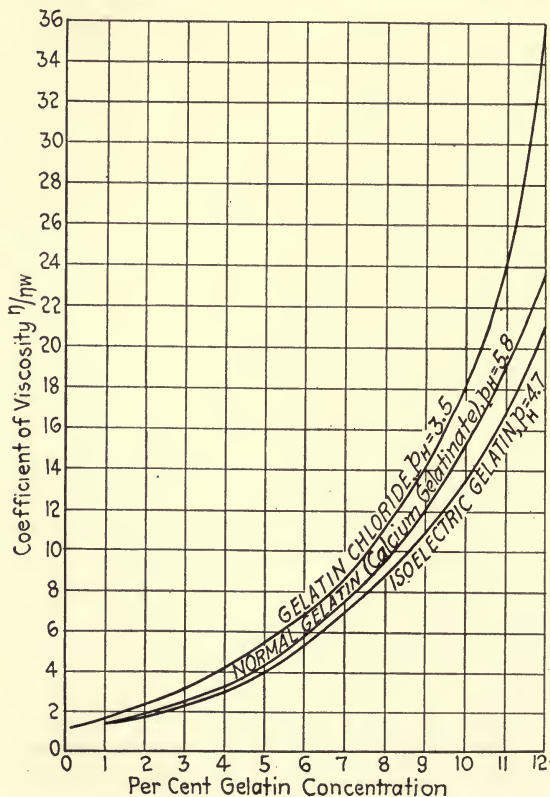

FIG. 21.—Relation of viscosity to concentration in gelatin solutions.

theory<sup>1</sup> which assumes that the viscosity curve will remain linear as long as the particles of dispersed phase do not touch each other, but becomes curvilinear when they occupy so great a volume that they are in close contact. The relations between viscosity and concentration of gelatin sols have been rigidly studied by the author<sup>2</sup> and the curves for a gelatin of three differ-

<sup>1</sup> *Vide* page 200.

<sup>2</sup> R. H. BOGUE, *J. Am. Chem. Soc.*, **43** (1921), 1764.

ent hydrogen ion concentrations, at 35°C., are shown in Fig. 21.

*Temperature.*—P. von Schroeder<sup>1</sup> has shown that while water increases in viscosity about 18 per cent on being reduced

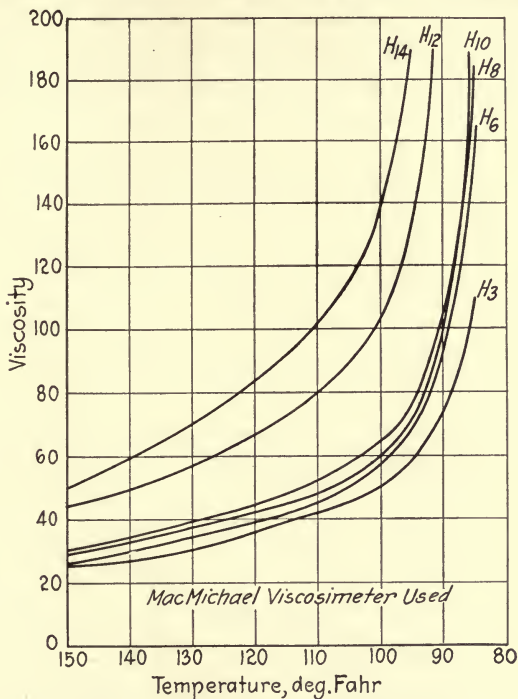

FIG. 22.—The effect of temperature upon the viscosity of hide glues.

in temperature from 31 to 21°C., a 3 per cent solution of gelatin through the same range showed an increase of nearly 1,000 per cent. At higher temperatures however a reduction of 10° would reveal a very much smaller increase. The same type of curve is obtained with glues as with gelatin, except that as the grade of the glue decreases, *e.g.*, as its content of gelatin (hydratable material) diminishes, the temperature at which a rapid rise begins is lowered. This will be clear from an inspection of Figs. 22 and 23, which show the viscosity in MacMichael degrees of standard hide and bone glues.

The influence of added substances upon the temperature-viscosity curve has been studied by the author.<sup>2</sup> Glues which

<sup>1</sup> P. VON SCHROEDER, *Z. physik. Chem.*, **45** (1903), 75.

<sup>2</sup> R. H. BOGUE, *Chem. Met. Eng.*, **23** (1920), 5.

had been treated with alums were found to react to increase in temperatures by a very profound drop in viscosity, which continued regularly. Glues that had been treated with formaldehyde responded in a different way. Between 30 and 40° the viscosity drops as the temperature rises, which is the normal behavior of untreated glues. Between 40 and 45 or 50°, how-

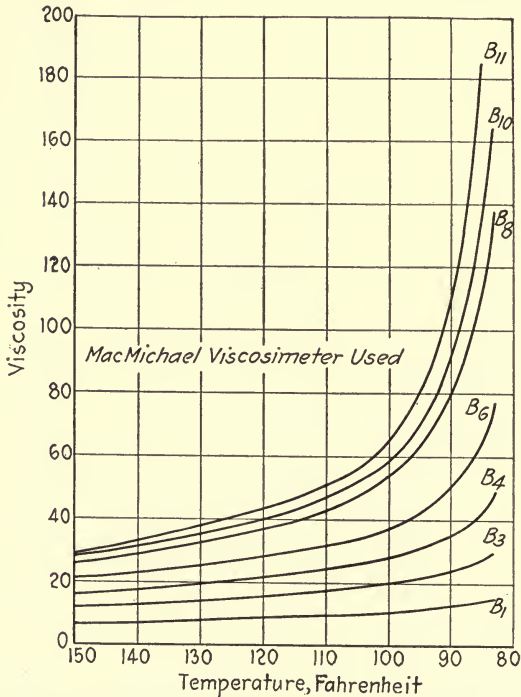

FIG. 23.—The effect of temperature upon the viscosity of bone glues.

ever, the viscosity remains nearly constant, and above 50° it rises sharply to the setting point. These data are illustrated in Figs. 24 and 25.

*Degree of Dispersion.*—Of the many factors which influence the viscosity of emulsoids the degree of dispersion is probably of greater importance than any other with the exception of concentration and temperature. It is in fact highly probable that the influence of many if not all of the other factors affecting viscosity is brought about through changes in the size of the particles of the dispersed phase. Thus alterations in the concentration or the temperature of the solution, as also the addition



of salts, acids, or alkalis, very probably alters the degree of ionization of the gelatin or the gelatin salt in solution. Any changes in the equilibrium of ionization will be reflected in like changes in the relation of positive to negative surface tension between the disperse phase and dispersion medium, and alterations in this surface tension ratio must result in changes in the

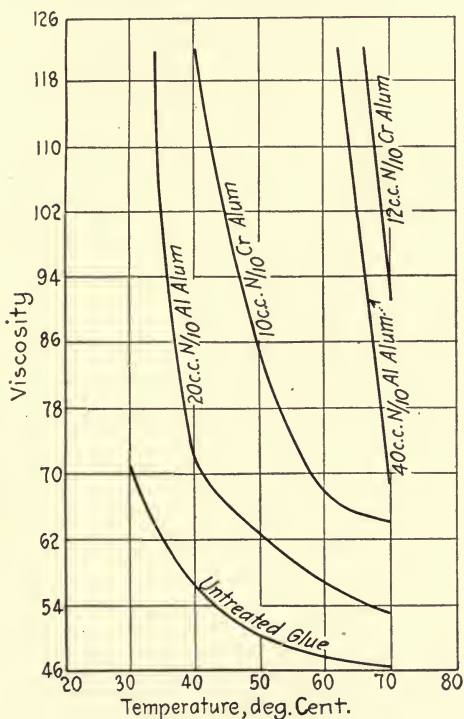

FIG. 24.—The effect of temperature upon the viscosity of alum-treated glues.

size of the particles.<sup>1</sup> So it seems highly probable that any change in viscosity from whatever cause is produced, in the last analysis, by alterations in the degree of dispersion and solvation.

The direction which the viscosity curve will take upon changes in degree of dispersion has been investigated by many workers, and the results obtained point to a medium dispersion as optimum for a maximum viscosity. For example Martici<sup>2</sup> found the

<sup>1</sup> Wo. OSTWALD—FISCHER, "Handbook of Colloid Chemistry," 1st ed., (1915), 181. J. VAN BEMMELEN, "Die Absorption," *Gesammelte Abhandl.*, Dresden (1910-22).

<sup>2</sup> MARTICI, *Arch. fisiol.*, 4 (1907), 133.

viscosity of oil emulsions in soap solution increased as the oil droplets became smaller. Buglia<sup>1</sup> found that milk which had been homogenized, by directing a stream of it swiftly against

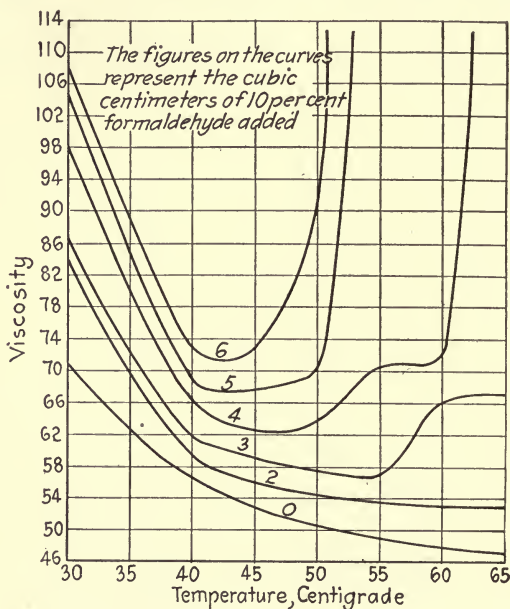

FIG. 25.—The effect of temperature upon the viscosity of formaldehyde-treated glues.

an agate plate, showed a noticeable increase in viscosity. In this case the particles of fat had become smaller. On the other hand Biltz and von Vegesack<sup>2</sup> found the maximum viscosity of colloid solutions of night-blue corresponded with the highest molecular weight, *e.g.*, with the largest size of particles.

The author<sup>3</sup> has succeeded in demonstrating definite maxima in viscosity throughout a constantly changing dispersity in experiments upon gelatin and glue. In studying the effects of added substances upon viscosity it was observed that the substances added might be divided into four groups with respect to their action on viscosity, *e.g.*, (1), those which raise the viscosity constantly; (2) those which lower the viscosity constantly; (3), those which raise the viscosity to a maximum beyond which they

<sup>1</sup> BUGLIA, *Kolloid-Z.*, **2** (1908), 353.

<sup>2</sup> BILTZ and VON VEGESACK, *Z. physik. Chem.*, **73** (1910), 500.

<sup>3</sup> BOGUE, *Chem. Met. Eng.*, **23** (1920), 5; 61.

produce a drop; and (4), those which have no appreciable effect. The third group is the most interesting and instructive. We find dilute sodium hydroxide and acetic acid both to fall in this group. As small amounts of these electrolytes are added to the glue solution, there is observed a very definite and constant increase in viscosity up to a certain point, and a slight further addition results in a sharp drop in viscosity to a solution of nearly watery consistency. While this has been going on the solution has become more and more turbid, but apparently homogeneous up to the point of maximum viscosity. But very shortly after the break in viscosity occurs, the emulsion also visibly breaks, and a flocculent precipitate is observed. The constantly increasing turbidity of the solution with its ultimate break seems to indicate a continually increasing size of particle in disperse phase, but the existence of a distinct peak in the viscosity curve can mean only that during the first part of the experiment the viscosity increased with decreasing degree of dispersion, while during the latter part the viscosity decreased with decreasing degree of dispersion. In other words the viscosity shows a distinct maximum at a medium dispersity of gelatin particles. Alexander,<sup>1</sup> however, prefers to regard this flocculent precipitation as resulting from "an *increased* dispersion involving or followed by the formation of a small quantity of an insoluble chemical or adsorption compound." Exactly what this "insoluble chemical or adsorption compound" is, or why it should be so produced, or his reasons for thinking that it exists, Alexander does not make clear.

*Solvate Formation.*—It has already been shown on page 164 that the swelling of gelatin involves a physical or a chemical combination of the substance with the elements of water. Experiments performed in the author's laboratory<sup>2</sup> have shown furthermore that the viscosity and degree of solvation are very closely related. Five gelatins of varying hydrogen-ion concentration were subjected to very careful viscosity determination at 35°C. by the use of an Ostwald viscosimeter. The viscosity curves varied greatly as has been shown on page 188. On calculating the volume occupied by unit weight of dispersed phase by Hatschek's formula<sup>3</sup> it is found that this volume is much greater

<sup>1</sup> J. ALEXANDER, *J. Am. Chem. Soc.*, **43** (1921), 434

<sup>2</sup> R. H. BOGUE, *J. Am. Chem. Soc.*, **43** (1921), 1764.

<sup>3</sup> *Vide* page 203.

at a pH value of 3.5, and lower at a pH value of 4.7 than at any other, and the coefficient of viscosity is found to vary in an entirely similar manner as is shown in the following table:

TABLE 36.—RELATION OF VISCOSITY TO SOLVATION 6 PER CENT SOL

pH	Coefficient of viscosity	Volume per unit weight
3.5	6.82	10.27
4.7	5.25	8.76
5.8	5.97	9.57

Since the volume of dispersed phase per unit weight is a direct measure of solvation, the above data show that the viscosity and solvation are parallel functions.

Further experiments<sup>1</sup> have however shown that the above relations do not hold strictly true under conditions near the gelation point. On regularly increasing the hydroxide ion concentration of a gelatin sol it was found that the degree of swelling and the viscosity regularly increased until the pH value had reached about 8.5, and thereafter decreased slightly. At the same time it was observed that the jelly consistency remained solid until the pH value had reached 8.5, but at that value it became soft, and at higher values remained liquid. At a pH value of 4.7 the jelly was again soft. That is, it reaches its maximum consistency at a medium degree of solvation, for at a pH of 4.7 the solvation attains its minimum value. The viscosity increases regularly with the solvation, therefore, up to a point where the increased tendency of the gelatin to liquify, or remain fluid due to increasing solubility, becomes greater than the increasing tendency to become more highly solvated.

Similar parallelism between viscosity and solvation has been observed by Pauli,<sup>2</sup> Ostwald,<sup>3</sup> Fischer,<sup>4</sup> Holmes,<sup>5</sup> and others. Pauli and Ostwald have pointed out that such close parallelism exists between the relative properties of dilute and concentrated solutions of gelatin that the viscosity of liquid sols may be employed for the study of imbibition phenomena.

<sup>1</sup> R. H. BOGUE, *J. Ind. Eng. Chem.*, **14** (1922), 32.

<sup>2</sup> Wo. PAULI, "Kolloidchemie der Eiweisskörper," Dresden, 1920.

<sup>3</sup> Wo. OSTWALD, *Trans. Faraday Soc.*, *loc. cit.*

<sup>4</sup> M. FISCHER, *J. Am. Chem. Soc.*, **40** (1918), 303.

<sup>5</sup> H. HOLMES, *ibid.*, **42** (1920), 2049.



*Electric Charge, or Ionization.*—Wo. Pauli<sup>1</sup> considers that changes in hydration are most frequently the basis for increase or decrease in the viscosity of protein solutions, and that alterations in the electric charges are in turn most frequently the basis for variations in the hydration.

When ordinary gelatin is placed in an electric field the gelatin is usually found to be ionized, and to migrate to the anode. If a small amount of acid is added this migration becomes less and less and eventually ceases altogether. This point is known as the isoelectric point, and is for gelatin defined by a hydrogen-ion concentration of  $2 \times 10^{-5}$  or  $\text{pH} = 4.7$ .<sup>2</sup> It has been shown by Loeb<sup>3</sup> that the viscosity of a gelatin solution reaches its minimum at this point, and that it rises on either side thereof, but with different rates according to the particular anion or cation with which it is brought into combination. This point will receive extensive treatment in a later section.<sup>4</sup> It is desired to emphasize at this time however that in all probability ionized particles of gelatin impart to a solution a greater viscosity than do the natural unchanged molecules. That this effect is very closely connected with hydration is shown by the fact that at the isoelectric point the swelling and the viscosity are also at their minimum values. This seems to indicate that the non-ionized particles possess the lowest power of combination with water, that this non-hydration results in a low viscosity, and that viscosity may accordingly be used as a measure of still another property, *i.e.*, the ionization of the protein. When it is remembered that every addition of any electrolyte, or the presence of such an impurity in the gelatin or the water, will probably result in changes in the hydrogen-ion concentration, and hence in the ionization of the gelatin, it will readily be appreciated that changes in viscosity by virtue of such changes in ionization and hydration may be considerable and, in any study of the proteins, of the very highest importance.

*The Previous Thermal Treatment.*—One of the curious anomalies of a gelatin solution is shown by the fact that if it is warmed and cooled several times it will reveal a lower viscosity

<sup>1</sup> WO. PAULI, *Trans. Faraday Soc.*, **9** (1913), 54.

<sup>2</sup> MICHAELIS, "Die Wasserstoffionenkonzentration," Berlin (1914).  
*Vide* also appendix page 581.

<sup>3</sup> J. LOEB, *J. Gen. Physiol.*, **1** (1918-19), 39; 237; 363; 483; 559.  
*Vide* Chap. V.

at a given temperature than normally. Also if the viscosity at, for example, 32°C. is desired, a difference will be observed if the gelatin solution is brought gradually up to 32° and then measured, or if it is first heated to 60 or 70°, and then cooled to 32° and measured. That such decrease in viscosity is not the result of hydrolysis of the gelatin to simpler substances is shown by the fact that on standing for several hours or days the original values may again be duplicated. Prolonged heating results in a permanent decrease in viscosity due to such hydrolysis, and in the latter case the former values may not again be obtained. The reason for *reversible* changes in viscosity is probably to be found in an alteration of the structure of the gelatin sol. This ~~has been~~ discussed in Chap. III.

*The Previous Mechanical Treatment.*—A decided reduction in viscosity is also noted as a result of vigorous agitation, stirring, or shaking, or even the passage of the solution several times through the capillary of a viscosimeter tube. This phenomenon, as that of the reduction of viscosity by preliminary heating, seems also to indicate a structure of some kind in the gelatin sol. This subject is discussed at greater length in Chap. III.

*Inoculation with Other Colloids.*—The addition of small quantities of a viscous colloid have been found to raise the viscosity, especially after standing for some time, to an incomparably higher degree than could be attributed to the increase in concentration due to such addition. A small piece of aged or gelatinized gelatin, for example, was found by Garrett<sup>1</sup> to greatly accelerate the rate of increase of viscosity with time.

*Time.*—When the temperature is not greatly above the congealing point of gelatin, very marked changes in viscosity with time are observed, the direction showing an increase. As the temperature becomes further and further removed above the point of gelation, however, the changes in viscosity with time become very small, pass through a zero point, and at higher temperatures show a decrease with time.<sup>2</sup> Experiments by von Schroeder<sup>3</sup> show an increase of 750 per cent in the viscosity of a gelatin solution on standing for 60 minutes at 21°C., while at 24.8° the increase was 1.5 per cent, and, at 31°, less than 0.1 per cent. The following table presents his data:

<sup>1</sup> GARRETT, *Phil. Mag.* (6), 6 (1903), 374.

<sup>2</sup> See page 150.

<sup>3</sup> P. VON SCHROEDER, *Z. physik. Chem.*, 45 (1903), 75.

TABLE 37.—INCREASE IN VISCOSITY WITH TIME

Time in minutes	At 21.0°	At 24.8°	At 31.0°
5	1.83	1.65	1.41
10	2.10	1.69	1.41
15	2.45	1.74	1.42
30	4.13	1.80	1.42
60	13.76	1.90	1.42

These results are shown graphically in Fig. 26.

The effect of the addition of some salts upon the viscosity-time curve has been studied by Gokun.<sup>1</sup> He found that the additions

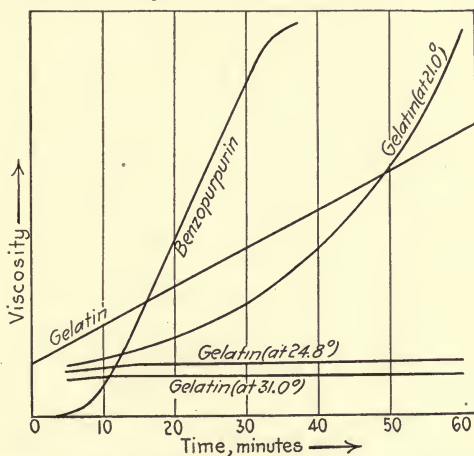

FIG. 26.—Increase in viscosity of emulsoids with time. (According to the experiments of P. von Schroeder, S. J. Levites and W. Biltz.)

of small amounts of ammonium nitrate accelerated the increase of viscosity with time; amounts between 0.32 and 1.4N resulted in no increase in viscosity; and still larger amounts of the salt produced a decrease in viscosity with time, as takes place in most suspensoids. Fischer explains these apparently antagonistic salt effects by assuming, first, an emulsification of the hydrated salt (solution) in the gelatin, and, second, that this is succeeded by emulsification of the gelatin in the hydrated salt (solution).

The author<sup>2</sup> has found that the initial very high viscosity of

<sup>1</sup> GOKUN, *Kolloid-Z.*, **3** (1908), 84.

<sup>2</sup> R. H. BOGUE, *Chem. Met. Eng.*, **23** (1920), 5.

glues which have been treated with alums declines rapidly with time until it approaches the initial value of the untreated glue. In the case of glues which had been treated with formaldehyde, however, the opposite effect was observed: the viscosity rose very rapidly with time. These effects are illustrated in Figs. 27 and 28.

*Addition of Foreign Substances.*—On account of the diversity of the possible substances which may be added to gelatin, both electrolytes and non-electrolytes, and the almost inde-

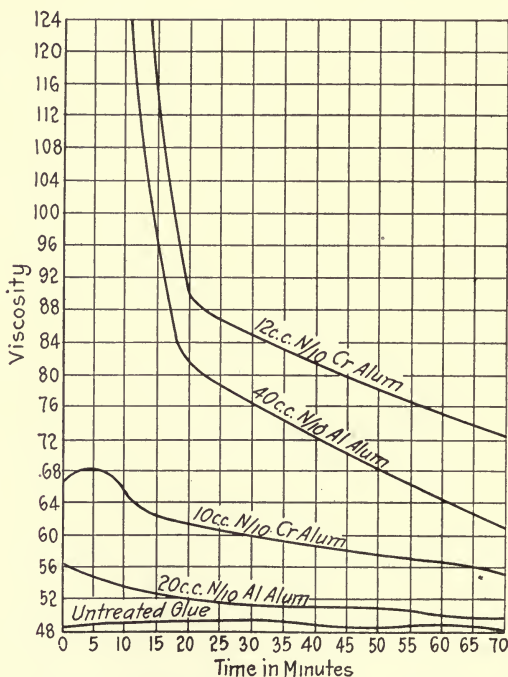

FIG. 27.—The effect of time upon the viscosity of alum-treated glues.

finite degrees in which such substances may affect the ionization, the hydration, the degree of dispersion, etc., of the product, it seems at first sight an almost hopeless proposition to arrive at any satisfactory basis for classifying such substances. Fortunately this phase of the gelatin problem has received considerable attention at the hands of capable investigators. Previous to 1916 however practically no success had been attained in the formulation of a scientific basis of classification: all such schemes were



of an empirical nature, as the well known Hofmeister<sup>1</sup> and Pauli<sup>2</sup> series. Loeb<sup>3</sup> has come to the conclusion that it is not only misleading but quite incorrect to express the effects of the several ions on viscosity and other properties in terms of an empirical order. Loeb worked, it should be noted, with quantities of

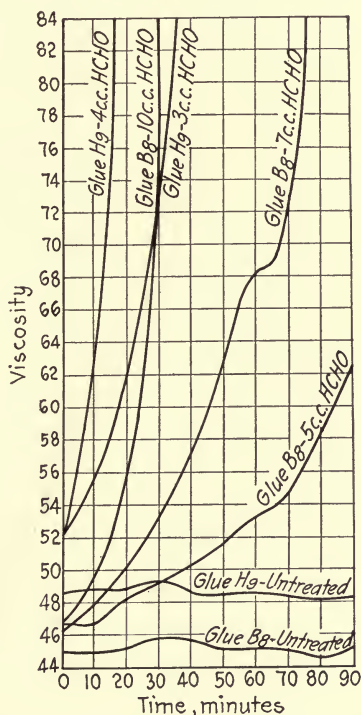

FIG. 28.—The effect of time upon the viscosity of formaldehyde-treated glues.

acids and bases which produced equal hydrogen-ion concentrations in the solutions, while Pauli and other previous investigators in this field had compared the effects of equal quantities of acids or bases. The diversity of their findings may very likely be ascribed to this fundamental difference in their method of experimentation. Fischer, however, in working with *anhydrous* soaps and solvents like alcohol, benzene, etc., has obtained the whole Hofmeister-Pauli series.

<sup>1</sup> HOFMEISTER, *Arch. exper. Path. Pharm.*, **24** (1888), 247. *Vide page 243.*

<sup>2</sup> PAULI, *Beitr. physiol. path. Chem.*, **3** (1903), 225; *Fortschr. naturwiss. Forschung*, **4** (1912), 237.

<sup>3</sup> J. LOEB, *J. Gen. Physiol.*, **3** (1920), 85.

A detailed treatment of this subject will be deferred to the following chapter, where all phases of the ionic and amphoteric character of gelatin will be considered. In Fig. 29 will be found curves reproduced from data obtained in the author's laboratory<sup>1</sup> which illustrate the great differences in viscosity produced by varying additions of electrolytes. It has already been pointed out that the differences observed are in all probability due to

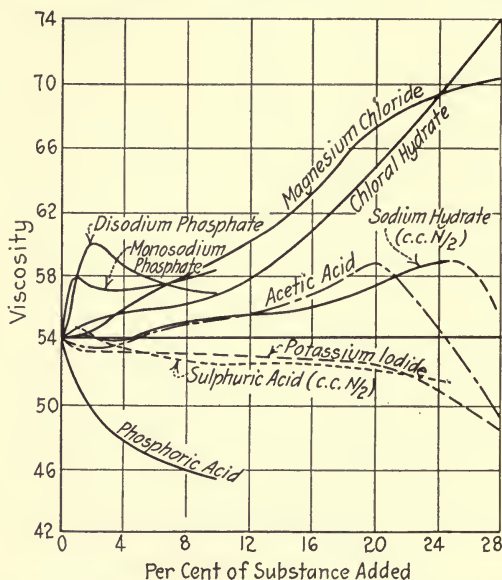

FIG. 29.—The effect of added substances upon viscosity.

alterations produced in ionization, hydration, and degree of dispersion.

**The Theories of Viscosity.** *Hatschek's Theory.*—A mathematical treatment of the principles of viscosity is one phase of the colloid situation which has not received a very extended investigation. In 1906 Einstein<sup>2</sup> published the first paper which considered the general expression of a law covering the viscosity of colloid solutions. Einstein by a thermodynamic determination of Avagadro's constant<sup>3</sup> obtained the expression for viscosity:

<sup>1</sup> R. H. BOGUE, *loc. cit.*

<sup>2</sup> A. EINSTEIN, *Ann. Physik.*, **19** (1906), 289.

<sup>3</sup> Avagadro's constant is the number of molecules in one c.c. of gas or liquid at 0°C. and 760 mm. pressure. See Lewis "System of Physical Chemistry, 2nd ed., London (1918), 42.

$$\eta' = \eta(1 + f), \quad (1)$$

where  $\eta'$  is the viscosity coefficient of the liquid, or continuous phase,  $\eta$  the viscosity of the system, and  $f$  the ratio of total volume of particles, or disperse phase, to total volume of the system. Hatschek<sup>1</sup> arrived at a nearly identical formula by a somewhat different line of reasoning. He argued that if a liquid is contained between two parallel plates, the lower of which is stationary while the upper is moved at constant velocity, the liquid at the upper pole of each particle in suspension will move at a somewhat greater velocity than at the lower pole, "which is equivalent to a translatory movement of the particles with a velocity equal to half the difference of the two velocities prevailing at the two poles." On carrying through this calculation Hatschek obtains the formula:

$$\eta' = \eta(1 + 4.5f). \quad (2)$$

It must be emphasized that the above formulas do not contain any functions of either the radius of the particles in suspension, or the distance by which such particles are separated, which reduces the expression to a statement that the viscosity of the system is independent of the size of the particles, and is a linear function of the volume of the disperse phase only. The formula assumes that the particles are spherical, of a smooth surface, and that they do not carry any layer of adsorbed solvent. Also, inasmuch as Stokes' formula is employed in the calculation, the formula of Hatschek holds good only between those limits defined by Stokes' law.<sup>2</sup>

Bancelin,<sup>3</sup> using a factor of  $2.9f$ , found the expression to hold for gamboge and mastic, and Harrison<sup>4</sup> also has found good agreement in starch solutions up to 30 per cent of disperse phase, but found the constant 4.75 must be employed. In an investigation upon sulphur, however, Odén<sup>5</sup> was not able to confirm the equation of Hatschek, for he found that when the concentration

<sup>1</sup> E. HATSCHKEK, *Kolloid-Z.*, **7** (1910), 301; **8** (1911), 34; *Trans. Faraday Soc.*, **9** (1913), 80.

<sup>2</sup> Stokes' law is expressed by the equation  $C = 6 \pi \eta r$  in which  $C$  is a constant dependent on the frictional resistance of the molecule,  $\eta$  the viscosity of the solvent, and  $r$  the radius of the molecule of the solute. See LEWIS, *loc. cit.*, 24.

<sup>3</sup> BANCELIN, *Kolloid-Z.*, **9** (1911), 154.

<sup>4</sup> HARRISON, *J. Soc. Dyers and Colonists*, **27** (1911).

<sup>5</sup> S. ODÉN, *Z. physik. Chem.*, **80** (1912), 709.

of his sulphur solution was raised above a certain value the viscosity increased more rapidly than in linear ratio, and that the viscosity of sols containing small particles is higher, for equal weights, than the viscosity of sols of larger particles. Hatschek in commenting upon these discrepancies recalls that all that is definitely known about the disperse phase is its weight, whereas

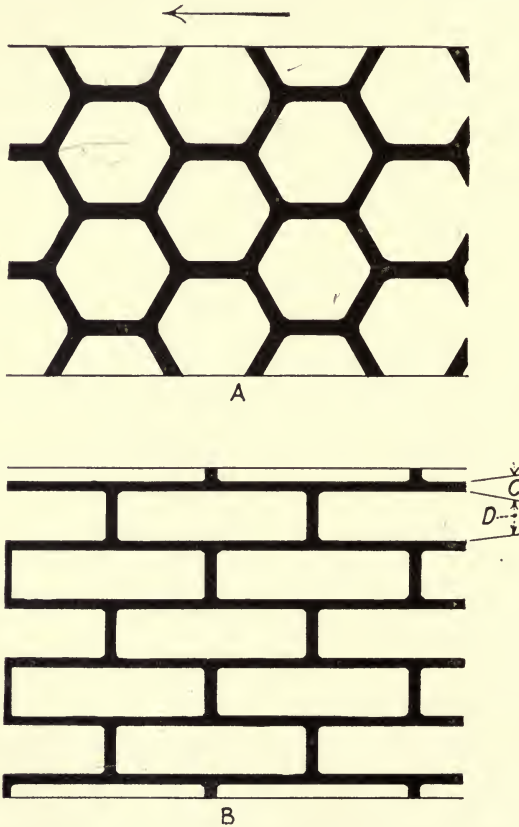

FIG. 30.—Hatschek's conception of the structure of emulsoid systems at rest (A) and in process of shear (B).

the formula requires an expression of volume. Assumptions are commonly made to the effect that the particles are of the same size throughout; of the same geometrical shape; of the same density irrespective of size, etc., but it is known that in substances of microscopic dimensions such assumptions are not justifiable. It is furthermore probable that a rotatory as well as



translatory motion is imparted to the particles in suspension, which would disturb the energy relations of the system. Finally the capillary viscosimeter may not be properly suited to viscosity measurements of colloid solutions.

In order to account for the high viscosities attained by emulsoids Hatschek further assumes that the disperse phase occupies a large proportion, often times much more than half, of the total volume. This assumption necessitates the development of dodecahedral shaped particles, each face of which is adjacent to a corresponding face of another particle, but separated therefrom by a film of the dispersion medium. This condition is shown in *A*, Fig. 30. When such a system is subjected to shear, the polyhedra must slide over one another until a position of least resistance is attained, and in this latter position the shearing takes place only in the horizontal films of continuous phase as shown in *B*, Fig. 30. Under such circumstances neither the viscosity of the disperse phase nor the interfacial tension enter into the calculation, and Hatschek produces the following equation, in which the viscosity of the continuous phase is taken as unity:

$$\eta = \frac{\sqrt[3]{A}}{\sqrt[3]{A} - 1}, \quad (3)$$

where  $\eta$  is the coefficient of viscosity of the system, and  $A$  is the ratio of the volume of the system to the volume of disperse phase.

In the case of emulsoid sols the actual volume of either phase cannot be definitely measured, and it is necessary to make some assumption that will give a basis for calculating the value of  $A$ . Hatschek therefore assumes that "at any given temperature the volume of disperse phase is a constant multiple of the volume—or weight—of the dissolved substance." This assumption has been tested as follows. A transformation of the previous formula may be written:

$$A = \left( \frac{\eta}{\eta - 1} \right)^3, \quad (4)$$

The value of  $A$  may thus easily be found, and since  $A = \frac{\text{total volume}}{\text{volume disperse phase}}$  this value should bear a constant ratio to the expression  $\frac{\text{total volume}}{\text{weight disperse phase}}$ , which will be called  $A'$ , *e.g.*, "the phase ratio must be a constant multiple of the per-

centage contents." It must be pointed out, however, that, inasmuch as the geometric structure upon which formula (3) is based cannot arise at concentrations of dispersed substance plus hydrated solvent which is attached thereto of less than about 50 per cent of the total volume, the formula may not be expected to function at lower concentrations than 50 per cent. At lower values the ratio of viscosity to dissolved substance is approximately linear as shown by formula (2).

*Application of Hatschek's Theory.*—The applicability of Hatschek's formula to gelatin has been rigidly tested by the author.<sup>1</sup>

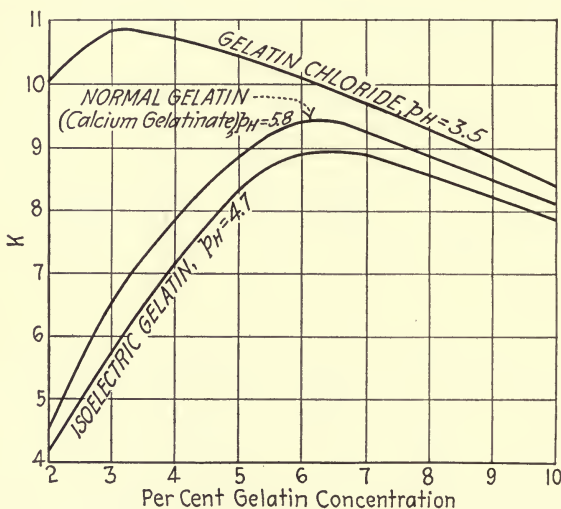

FIG. 31.—Variation in  $K$  with concentration of gelatin.

It was found that the value of  $A'/A$ , representing the volume occupied by unit weight of the dispersed phase, was not a constant with varying concentration, but that this value rose regularly to a maximum, and thereafter fell regularly with increasing concentration. This is shown in Fig. 31. This effect moreover is not confined to gelatin, but is found to obtain in the glycogen sol of Botazzi and d'Errico<sup>2</sup> and the casein sol of Chick and Martin,<sup>3</sup> reported by Hatschek.<sup>4</sup> Inasmuch as these variations are perfectly regular and invariably noted they may not be

<sup>1</sup> R. H. BOGUE, *J. Am. Chem. Soc.*, **43** (1921) 1764.

<sup>2</sup> BOTAZZI and d'ERRICO, *Pflüger's Arch. Physiol.*, **115** (1906), 359.

<sup>3</sup> CHICK and MARTIN, *Kolloid-Z.*, **11** (1912), 102.

<sup>4</sup> HATSCHEK, *Trans. Faraday Soc.*, **9** (1913), 80.

attributed to experimental error, but must be fundamental. This decrease in volume per unit weight of dispersed material after the concentration has reached a particular value may be due either to an increasing surface tension of dispersion medium or to a reversal of phase. It is apparent that by increasing the concentration of the dispersed particles, the film of continuous phase separating them will become ever thinner and thinner, and in so doing vastly increase the free surface of dispersion medium. Any such increase in free surface will be opposed by surface tension forces, and the thinner the film the greater will be the force opposing further increase in surface. This force may be conceived of as entering into competition for the solvent with the force which induces solvation in the dispersed particles. Writing this in the form of an equilibrium:

$$\text{surface tension} \rightleftharpoons \text{solvation potential.}$$

It is observed that increasing the dispersion medium favors solvation, while increasing the dispersed phase raises the surface tension in the continuous phase and thereby decreases the solvation. This means that the volume per unit weight of dispersed phase will decrease after the concentration has passed a certain optimum value, which accords with the experimental findings.

The extent of such decrease was shown by the author to be defined approximately by the equation:

$$\sqrt[3]{V_m^0} - \sqrt[3]{V_m} = s,$$

where  $V_m^0$  is the volume of the dispersion medium at the point where the value  $A'/A$  has attained its maximum, and  $V_m$  the volume of dispersion medium at any other concentration,  $s$  being the surface tension effect on the decrease in volume per unit weight of dispersed phase at increasing concentrations.

Hatschek<sup>1</sup> regards it as probable that the failure to obtain a constant value for  $K$  may lie in the nonconformity of the gelatin molecules to the conditions of the hypothesis, *e.g.*, they may not be spherical and produce simple polyhedra upon crowding. Or the assumption that the continuous phase is pure dispersion medium, and that all the colloid is in the disperse phase, associated with some of the dispersion medium, may be an undue simplification of the conditions. "It is probable," he writes, "that the dispersion medium also contains some of the colloid, and the

<sup>1</sup> E. HATSCHKEK, personal communication.

ratio colloid in disperse phase to colloid in continuous phase may become smaller with increasing concentration." To this Fischer would add that the gelatin may be either liquid or solid.

*Robertson's Theory.*—Robertson<sup>1</sup> explains the high viscosities of emulsoid sols in a slightly different manner. He recalls the researches of Graham<sup>2</sup> who showed that the velocity of diffusion of crystalloids through gelatin jellies was very nearly as great as through water, and the confirmation of such results by Voightländer<sup>3</sup> and Hüfner.<sup>4</sup> Bechhold and Ziegler<sup>5</sup> found the gelatin jellies to retard diffusion of crystalloids, but to a degree incomparably smaller than would be expected from the viscosity. Dumanski<sup>6</sup> has further shown that the conductivities of inorganic salt solutions in gelatin jellies is only slightly less than those of equally concentrated solutions in pure water. Robertson further emphasizes the fact that the conductivity of non-colloid solutions, as sugar, glycerine, etc., is profoundly influenced by slight increases in viscosity, whereas in colloid solutions the conductivity varies normally as the dilution quite irrespective of the much greater accompanying variation in viscosity.

In accounting for these anomalies Robertson turns to the net-structure theory.<sup>7</sup> He argues, that, if the protein or colloid be assumed to possess a structure somewhat similar to that of a tennis net, it will offer practically no resistance to the passage through it of rapidly moving small particles, except as the particles may occasionally impinge upon the meshes of the net. Therefore conductivity, which is a measure of the rate of migration of ions, would be but very slightly modified due to the presence of the gelatin "net." On the other hand, a viscosity measurement would be considerably influenced by such a structure, for all methods of measuring viscosity would involve a deformation of any such structure. We are unable by viscosity measurements to differentiate between viscosity resulting from a structure, and to that attributable only to what is known as the internal friction. Some objections have been raised to this

<sup>1</sup> ROBERTSON, "Physical Chemistry of the Proteins" (1918), 320.

<sup>2</sup> GRAHAM, *Trans. Roy. Soc., London*, **140** (1850), 1; 805; **141** (1951), 483.

<sup>3</sup> VOIGHTLÄNDER, *Z. physik. Chem.*, **3** (1889), 316.

<sup>4</sup> HÜFNER, *ibid.*, **27** (1898), 227.

<sup>5</sup> BECHHOLD and ZIEGLER, *ibid.*, **56** (1906), 105.

<sup>6</sup> DUMANSKI, *ibid.*, **60** (1907), 553.

<sup>7</sup> *Vide* Chap. III.



conception of viscosity, and discussion of them will be found in Chap. III

**The Viscosity-plasticity Relationship.**—The significance of a transitional temperature in gelatin "solutions" has recently been receiving much attention by chemists.

In a general sense it has long been recognized that whereas very dilute solutions (1.0 per cent) of pure gelatin would gel at low temperatures (10°C.), yet that above certain temperatures, roughly placed at about 35°C., gelation would not take place at any concentration. Exceedingly viscous solutions might be obtained, but the ability of these to congeal to a jelly was not observed above this temperature.

In a sense, the melting point of a gelatin or glue has been taken as the critical temperature, as is the case with crystalloids, but melting point is not at all easily obtained or even defined when such substances as gelatin are under consideration. Many attempts have been made however to determine this property. Cherceffski<sup>1</sup> measured the temperature at which small cubes of the jelly become soft enough to lose their cohesion. Kissling<sup>2</sup> noted the temperature at which the surface of a jelly in a test tube placed horizontally became inclined. Winkelblech<sup>3</sup> shook a glue solution in cold water until the material had reached a consistency such that the thermometer placed vertically therein remained stationary. Küttner and Ulrich<sup>4</sup> describe the use of Cambon's fusiometer which consists of a metallic bowl of given dimensions and weight. A glue is allowed to gel therein, a rod being held in a vertical position in the solution. The whole is then placed in a beaker of warm water, suspended by the rod, and the temperature at which the bowl drops from the rod taken as the melting point. Herold<sup>5</sup> allowed a thermometer to become congealed in a test tube of glue, and noted the temperature at which the tube fell away from the thermometer when suspended in warm water. C. R. Smith<sup>6</sup> determined the temperature at which a gelatin solution maintained a stipulated degree of viscosity, as determined by the "bubble" methods. Sheppard and

<sup>1</sup> CHERCHEFFSKI, *Chem. Ztg.*, **25** (1901), 413.

<sup>2</sup> KISSLING, *Z. angew. Chem.*, **16** (1903), 398.

<sup>3</sup> WINKELBLECH, *ibid.*, **19** (1906), 1260.

<sup>4</sup> KÜTTNER and ULRICH, *Z. öffent. Chem.*, **13** (1907), 121.

<sup>5</sup> HEROLD, *Chem. Ztg.*, **34** (1910), 203.

<sup>6</sup> C. R. SMITH, *J. Am. Chem. Soc.*, **41** (1919), 146; *J. Ind. Eng. Chem.*, **12** (1920), 878.

Sweet<sup>1</sup> have determined the temperature at which bubbles of air under a definite low pressure cease to flow through a gelatin sol.

None of the above may be regarded as absolute melting point determinations in the classical conception of the term. A very appreciable time factor enters into the above determinations which prevents an exact coincidence of the melting and solidification or setting points. The fact must be met that in such systems as these the transition from the hydrosol to the hydrogel condition is continuous, as far as our ability to measure the "points" of change is concerned, and to quote Sheppard, "both the 'melting point' and the 'setting point' are more or less arbitrary conceptions, and their determination depends mainly upon standardized experimental conventions." Sheppard defines "melting point" and "setting point" by an application of Clerk Maxwell's elasticity theory:

$$E = \frac{\eta}{T},$$

where  $E$  = the elastic modulus,  $\eta$  = coefficient of viscosity, and  $T$  = time of relaxation, *i.e.*, time for a deformation to fall to  $1/e$  of its initial value. He argues that "the 'melting point' is the temperature at which the elastic modulus becomes very small. Since  $\eta$  remains of considerable magnitude, this can only be by  $T$  becoming very large. Hence, both 'melting point' and 'solidification point' (setting point) might be defined as the convergence temperature at which the 'time of relaxation' becomes infinite."

Fischer<sup>2</sup> accounts for the differences observed between the temperatures of coagulation and of melting by his theory of mutual solubility of the two phases in the gelatin water system, and the influence of heat upon that solubility. At high temperatures he assumes liquid hydrated gelatin dissolved in water. At low temperatures, water dissolved in solid hydrated gelatin. At intermediate temperatures an equilibrium of the two may exist, and time is necessary for the attainment of equilibrium in a system of two mutually soluble substances.

The actual melting point temperatures obtained by the several methods mentioned above lie for the most part between 30° and

<sup>1</sup> S. E. SHEPPARD and S. SWEET, *J. Ind. Eng. Chem.*, **13** (1921), 423.

<sup>2</sup> MARTIN FISCHER, "Soaps and Proteins," New York (1921), p. 70 *et seq.*

35°C. when a high grade of gelatin is employed, and at somewhat lower temperatures with the lower grades of gelatins and glues. But at best these methods are based upon arbitrarily selected "experimental conventions."

In a study upon the mutarotation of gelatin C. R. Smith<sup>1</sup> has shown that at temperatures above 33° to 35°C. the specific rotation of gelatin is practically constant at about  $-123^\circ$ , while at temperatures below 15°C. the specific rotation is practically constant at about  $-266^\circ$ . At all temperatures intermediate between 35° and 15°C. the rotation varies between these two limits. Smith arrives at the conclusion that gelatin in aqueous solution exists in two modifications: the one stable at temperatures above 33° to 35°C. which he denotes as Sol form A, and the other stable at temperatures below 15°C. which he denotes as Gel form B. "Between these temperatures a condition of equilibrium between the two forms exists and the mutarotation observed seems to be due to the transformation of one form into the other by a reaction which is reversible with temperature."

Smith showed further that the presence of only 0.60 to 1.00 per cent of Gel form B was required in order to effect gelation. Thus at temperatures of 10° to 15°C., at which the gelatin is completely in the gel state, a 0.60 to 1.00 per cent solution will gel, while at 33° to 35°C., since the gelatin is here completely in the sol state, it will not gel at any concentration. At a very slightly lower temperature and a high concentration there may be just enough of the Gel form produced to result in gelation.

The temperature 33° to 35°C. is therefore regarded by Smith as the maximum gelation temperature, and by virtue of the significance attached to it as the equilibrium temperature between the sol and gel forms, it may be regarded with somewhat more reason as a critical temperature, and is based upon somewhat sounder principles than the melting point determinations (as applied to gelatin).

Bingham and Green<sup>2</sup> have made exhaustive studies of the laws of plastic flow, the measurement of plastic flow, and the applications of plastic flow to industrial processes, and Bingham<sup>3</sup> has

<sup>1</sup> C. R. SMITH, *loc. cit.*

<sup>2</sup> E. C. BINGHAM, U. S. Bureau of Standards *Bull.* **13** (1916-17), 309; E. C. BINGHAM and H. GREEN, *Proc. Am. Soc. for Test. Mat.*, **19** (1919); 640; H. GREEN, *ibid.*, **20** (1920), 451.

<sup>3</sup> E. C. BINGHAM, *ibid.*, **18**, Pt. II, (1918), 373.

described a variable pressure method for the measurement of viscosity.

It has been shown that a viscous liquid will start to flow no matter how small a pressure is applied. With plastic materials no flow takes place until after the pressure has exceeded a certain definite value. Bingham points out that when viscosity determinations are made by noting the volume of outflow of the liquid in a given unit of time, and this volume plotted against a variable but rigidly controlled and accurately measured pressure, an extension of the curve to the axes will pass through the origin, or zero point of the axes, provided the substance obeys the laws

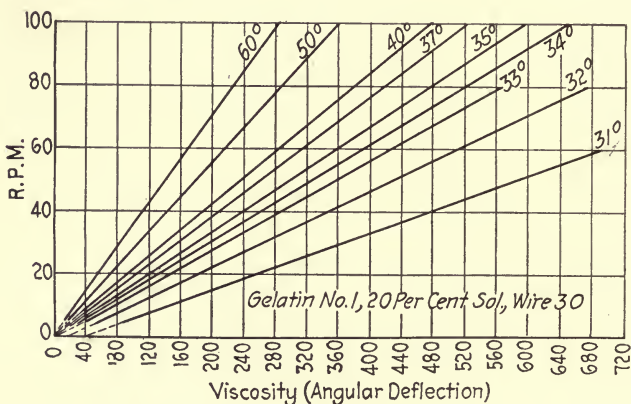

FIG. 32.—Viscosity-plasticity curves.

of a truly viscous liquid, but that the extension of the curve will fall upon the pressure axis at a finite distance ( $f$ ) from the volume axis if the substance is a plastic solid. This distance, ( $f$ ), Bingham calls the *yield value*, and defines it as the force required to start the flow. It is found to be a function however of the size of the capillary used, as well as of the material itself.

It seems that equally comparable, although perhaps less sensitive measurements for the determination of the viscosity-plasticity relations may be made by the use of a torsional viscosimeter of the MacMichael type. By varying the speed of rotation of the cup the same effect is produced as by varying the pressure in the capillary tube type of instrument. A study of gelatin solutions was conducted in the author's laboratory by this method.<sup>1</sup>

<sup>1</sup> R. H. BOGUE, *J. Am. Chem. Soc.*, **44** (1922), 1313.



*Viscosity-plasticity Studies.*—The procedure employed was as follows. Several lots of the highest quality of granulated gelatin were utilized in the tests. These were made up accurately into 10, 20, and 25 per cent solutions by soaking in cold water for one hour, dissolving in a water bath at 70°C., again making up accurately all water lost by evaporation, and with no delay, introducing into the cup of the viscosimeter. The latter is at the same temperature as the gelatin solution, and is immersed in the water bath, which is a part of the instrument, at a temperature of 70°C. The heating process for bringing the gelatin into solution is made as brief as possible. The cover of the instrument is kept on the cup to prevent evaporation during the measurements.

The solution was kept thoroughly stirred by lifting the plunger up and down, and the temperature permitted (by use of the electric heating unit) to fall very slowly. The viscosity was taken intermittently as the solution cooled until it became too viscous to measure.

The velocity of rotation of the cup was carefully adjusted before and after the measurements. Each series, as above, was measured at the same velocity of rotation throughout the temperature range from 60° to 31°C., or lower, and then the velocity changed. Speeds from 5 to 100 r.p.m. were used.

The whole was repeated for the three concentrations used, and again repeated with the employment of differently sized wires in the instrument.

An example of the data obtained is shown in graph form in Fig. 32.

In the foregoing figure the velocity of rotation is plotted against angular deflection.

An examination of these curves shows that by continuing each downward until it intercepts the axis two conditions are made manifest. In one of these conditions the origin of each curve is the zero point of the axes. In general, all curves plotted from temperatures higher than 34°C. are of this type. In the other condition, the origin of the curves lies at some point on the viscosity axis at a varying distance from the ordinate representing r.p.m. The lower the temperature the further is the point of interception with the abscissa removed from the convergence point of the axes.

This seems to mean, arguing from the geometry of the graphs, that in those cases where the intercept lies on the abscissa an infinitely small velocity of rotation will result in a viscosity deflection of finite magnitude. That is, the gelatin, under those conditions, offers a permanent and fixed resistance to deformation. It is an elastic body; it possesses a measurable degree of rigidity; and deformation may not occur until after a certain minimum of pressure exerted against it, has been exceeded. And these are, as a matter of fact, the very attributes which are characteristic of plastic substances.

If it were necessary to carry the analogy further we could say that the distance from the origin of the axes to the point of intersection corresponds very closely to, although it is not identical with, the yield value,  $f$ , as obtained by Bingham's method. The magnitude of this distance may correctly be taken as a measure of the plasticity of the material.

It will be observed that at velocities of rotation above 60 r.p.m. there is, in some cases, a slight bending of the curves away from the velocity axis. That is, at the higher speeds of rotation, the observed viscosity is somewhat greater than should obtain if the lower (straight) portion of the curve may be regarded as most correctly expressive of the true theoretical values. The reason for this bending is undoubtedly to be found in an instrumental error by which eddy currents are set up within the liquid when the velocity exceeds a certain value. There is also very probably produced at the higher velocities a slipping of the liquid along the sides of the cup causing it to move to a greater degree *en masse* rather than by the telescopic shear of truly viscous flow.

Above a certain temperature (at any given concentration) the curves follow the laws of truly viscous flow, *e.g.*, they converge, when extrapolated to the axes, at the origin. In other words the observed angular deflection is directly proportional to the speed of rotation. But at a given temperature (for a given concentration), and at all temperatures below this point, the curves follow the laws of plastic flow as above pointed out. Our "solution" of gelatin behaves, therefore, as a viscous liquid at elevated temperatures, and as a plastic solid at low temperatures (but still above the solidification point).

If we may accept C. R. Smith's conclusions that above 33° to 35°C. the sol form only may exist, while below that temperature increasing amounts of the gel form are in equilibrium with the former until at 15° the gel form only is stable, then it seems to follow from the data observed that gelatin sol is a viscous liquid while very small amounts of gelatin gels are sufficient to impart to the "solution" the properties of plastic flow. (See also page 148.)

#### 4. THE THEORY OF EMULSIONS

Since gelatin and glue are frequently made use of in the preparation of emulsions, it becomes necessary that the emulsion condi-

tion be understood and the several theories upon emulsification be presented.

Technically, an emulsion differs from an emulsoid only in the size of the dispersed particles. It consists essentially of small droplets of one liquid dispersed in another liquid. In order to bring this condition about, however, it is usually necessary that a third substance, known as an emulsifying agent, be present. Emulsions which are produced without an emulsifying agent are invariably of only transient existence. Violent shaking, for example, of an oil and water may produce an emulsion, but unless some stabilizing substance is present, it will break immediately when the shaking is stopped. It is in the capacity of an emulsifying agent that gelatin or glue are often used.

*Types of Emulsions.*—Emulsions are customarily considered as of two types: (1) the oil in water type, which consists of droplets of oil dispersed in water, and (2) the water in oil type which consists of droplets of water dispersed in the oil.

The two types may be distinguished in several ways. If water is the external phase, the emulsion will wet substances in the usual way, while if oil is external it will feel oily and produce the typical grease spot on paper. If a drop of emulsion is added to another drop of the external phase, it will disperse and mix freely, but on its addition to another drop of the internal phase there will be no tendency for the two to unite. Robertson<sup>1</sup> suggested applying the dye *Soudan III* which is soluble in oil but not in water. On shaking with an emulsion where oil is the external phase the entire emulsion will be stained red but if the emulsion is of the oil-in-water type only the oil droplets will be colored. Thomas<sup>2</sup> does not, however, regard this as a reliable means of determining the distribution of phases. Newman<sup>3</sup> has used iodine in his benzene-water emulsions, the iodine being soluble in the benzene and not in the water, thus confining itself to the phase in which the benzene is present. Methyl orange was similarly used, it being soluble in water but insoluble in benzene.

Whether the water-in-oil or the oil-in-water type of emulsion will be formed under any given set of conditions has been the subject of a great deal of discussion. Walther Ostwald<sup>4</sup> in 1910

<sup>1</sup> ROBERTSON, *Kolloid-Z.*, **1** (1910), 7.

<sup>2</sup> A. W. THOMAS, personal communication.

<sup>3</sup> NEWMAN, *J. Phys. Chem.*, **18** (1914), 34.

<sup>4</sup> WALTHER OSTWALD, *Kolloid-Z.*, **6** (1910), 103; **7** (1910), 64.



urged that the ratio of the concentrations of the two phases was the determining factor. He argued that for any two immiscible substances there was a critical concentration, upon one side of which the emulsion would be of one type, and upon the other side, the other type. There has been much opposition to this point of view. Bancroft<sup>1</sup> maintained that an elasticity of shape could be assumed whereby the space between the particles might be vanishingly small, and Briggs and Schmidt<sup>2</sup> have shown that at a given concentration either type could be produced by a proper selection of emulsifying agent.

*Bancroft's Theory of Emulsion Formation.*—A lowering of the surface tension of one of the two liquids has long been regarded as a most important factor. Plateau<sup>3</sup> in 1870 and Quincke<sup>4</sup> in 1888 suggested the influence of "surface activity." Bancroft<sup>5</sup> states that "if the surface tension between Liquid A and the emulsifying agent is lower than the surface tension between Liquid B and the emulsifying agent, Liquid A will be the dispersing and Liquid B the disperse phase." He adds that an aqueous colloid (hydrophile) as an emulsifying agent will tend to make water the external or continuous phase, while a non-aqueous colloid (hydrophobe) will tend to make water the internal or dispersed phase. This idea was also early advanced by Fischer.<sup>6</sup> Thus gelatin, being a hydrophile, tends to produce the oil-in-water type of emulsion. In general, if the emulsifying agent is wetted more easily by water than by oil, then water will be the external phase, while if the emulsifier is more easily wetted by the oil, then the oil will be the external phase.

In order that a substance may function as an emulsifying agent, it must, according to Pickering<sup>7</sup> and Bancroft,<sup>8</sup> pass into the *dineric interface* (the surface separating the two liquid phases), and form a coherent film there. Unless such a coherent film is formed the emulsion will crack, and if it does not pass into the dineric interface at all, no film will be formed around the droplets of the dispersed phase, which Bancroft regards as funda-

<sup>1</sup> W. D. BANCROFT, *J. Phys. Chem.*, **10** (1912), 179.

<sup>2</sup> BRIGGS and SCHMIDT, *ibid.*, **19** (1915), 478.

<sup>3</sup> S. PLATEAU, *Ann. Physik.*, **141** (1870), 44.

<sup>4</sup> G. QUINCKE, *ibid.*, **271** (1888), 580.

<sup>5</sup> W. D. BANCROFT, *J. Phys. Chem.*, **17** (1913), 501.

<sup>6</sup> Cf. MARTIN FISCHER, "Edema and Nephritis," New York (1915).

<sup>7</sup> S. N. PICKERING, *cit. sup.*

<sup>8</sup> W. D. BANCROFT, *J. Phys. Chem.*, **19** (1915), 273.



mental to the production of a permanent emulsion. Thus in an emulsion of oil and water, in which gelatin is used as the emulsifier, the gelatin would, according to Bancroft, concentrate at the dineric interface of the oil and water, as the system was shaken and, the gelatin being a hydrophile, form an elastic continuous film around each little droplet of oil. If the emulsifier is a solid, he concludes from experiments by Hofman<sup>1</sup> and by Des Condres<sup>2</sup> that "the solid particles tend to go into the water phase if they adsorb water to the practical exclusion of the other liquid; they tend to go into the other liquid phase if they adsorb the other liquid to the practical exclusion of the water; and they tend to pass into the dineric interface in case they adsorb the two liquids simultaneously."

*Pickering's Theory.*—These conclusions are very similar to those reached by Pickering<sup>3</sup> in an exhaustive study on emulsions in 1907. Pickering found that the insoluble basic salts of iron, copper, nickel, and aluminum, and even clays, lime, silica, and plaster of paris functioned as good emulsifying agents with respect to mineral oil and water. He concluded that the essential factor in emulsification was the formation of a solid film around the dispersed droplets, and that, in general, the smaller the size of the particles of the emulsifier, the more stable would be the resulting emulsion.

*Clowes' Theory.*—Clowes<sup>4</sup> found that he could bring about a reversal of phase in an olive oil-water emulsion, where sodium oleate was the emulsifying agent, by the addition of proper amounts of calcium chloride. That is, his sodium oleate was converted to calcium oleate, and whereas the sodium, potassium, and lithium soaps are soluble in water, and not in oil, thereby emulsifying oil in water, the soaps of the divalent and trivalent metals were soluble in oil and not in water, and thus emulsified water in oil. Clowes adheres to the Pickering-Bancroft theory of film formation, but finds that the nature of the film changes. Calcium oleate alone gives one type and sodium oleate alone the other type. At some particular mixture, as represented by some particular ratio of calcium to sodium oleate in the solution, the effects of the two oleates will just balance.

<sup>1</sup> HOFMAN, *Z. physik. Chem.*, **83** (1913), 385.

<sup>2</sup> DES CONDRES, *Arch. Entwicklungsmechanik*, **7** (1898), 325.

<sup>3</sup> PICKERING, *J. Chem. Soc.*, **91** (1907), 2001; *Kolloid-Z.*, **7** (1910), 15.

<sup>4</sup> G. CLOWES, *J. Phys. Chem.*, **20** (1916), 407.

*Fischer's Theory.*—Martin Fischer<sup>1</sup> takes exception to the tenuous film theory above described, on the ground that Pickering makes assumptions which are not justified. For example, Pickering, in explaining the stability of an emulsion of oil in soap, needs to assume the soap always to be contaminated with stearin particles, which Fischer shows is not necessarily the case. Fischer's theory, in his own words, is as follows: "An emulsion is stabilized only through the addition of a lyophilic (hydrophilic) colloid. The amount of colloid necessary is relatively great. It must be sufficient, at least, in the production of an emulsion, to bind all the water if an emulsion showing real permanence is to be produced. Differently expressed; the production of a lasting emulsion, as of oil in water, is really never obtainable through the division of the former into the latter, but only through the division of the oil into a hydrated (solvated) colloid." Thus when it is said that gelatin, for example, favors the formation and stabilization of an oil-in-water emulsion, the theory of Fischer would have it that the gelatin is a hydrophilic colloid which, with water, forms a colloid hydrate, and the oil is dispersed in this medium: not in water *per se*.

The various emulsifying agents are of different degrees of efficacy in their emulsifying power essentially on account of the various solvation potentials which they display. High viscosity is of great advantage, but is necessarily secondary to the property of hydration. "Lasting emulsions of oil in gelatin are obtainable only by dispersing the oil in a gelatin mixture of a concentration which is just fluid at the temperature at which the experiment is carried out. If with such a gelatin colloid the temperature is raised (and its degree of hydration thereby decreased) a less permanent emulsion results. On the other hand, an emulsion of oil in gelatin remains fixed if the mixture is chilled to below the gelation point of the gelatin."

That the hydration theory of Fischer and the interfacial film theory of Bancroft and Pickering are not necessarily irreconcilable to each other has been urged by Fischer, although Bancroft and Clowes have taken exception to the hydration hypothesis. When Clowes considers that the stabilizing effect of sodium oleate upon an oil-in-water emulsion is due to a lowering of the surface tension of water, Fischer regards the stabilization as being due

<sup>1</sup> M. FISCHER and M. HOOKER, *Science*, N. S., **43** (1916), 468; "Fats and Fatty degeneration," New York (1917), 29.

to a division of the oil in a highly hydratable sodium soap. The destructive action of calcium upon the emulsion Fischer considers as due, not to complicated changes in the surface film, but to the fact that the calcium oleate is an only slightly hydratable soap.

*Holmes' Theory.*—In a more recent contribution to the subject of emulsions Holmes and Child<sup>1</sup> affirm that too great viscosity is just as prejudicial to emulsion stability as too little. They maintain that the maximum lowering of surface tension should be secured, but that this is obtained just as well by 0.3–0.4 g. of gelatin per 100 c.c. of water as by 1.0 g. Viscosity, they assert, is the leading factor in oil-water emulsification where gelatin is used “not the maximum, but the most favorable viscosity,” which is in fact “only a little beyond that of water.” They find no evidence that gelatin particles form adhesive layers about the oil droplets, nor do they find evidence that as the oil content is increased, the gelatin content must also be increased to maintain the original stability of the emulsion, as would be required if adhesion layers were formed about the oil droplets. “One gelatin content in a given volume of water can be selected that will make the best emulsion for all oil contents.” Their findings in general tend to favor the hydration hypothesis of Fischer, but they do not distinguish, as Fischer does, between liquid hydrated gelatin and solid hydrated gelatin. An optimum, rather than the maximum viscosity, may be explained by the fact that medium sized particles seem to be susceptible of the highest degree of hydration<sup>2</sup> and it is the gelatin possessing the highest degree of hydration which will produce the best emulsion. As viscosity is a measure of the size of the particles, an optimum rather than a maximum viscosity would be expected to produce the best emulsion.

*Winkelblech's Theory.*—In 1906 Winkelblech<sup>3</sup> found that if a hydrocarbon, such as benzine, benzene, chloroform, etc., is shaken with water in which is dissolved a little gelatin or glue, a stiff emulsion is produced. If the gelatin was present only in very small amounts, a layer of small bubbles formed at the interfacial surface which, on breaking, left a permanent whitish

<sup>1</sup> H. HOLMES and C. CHILD, *J. Am. Chem. Soc.*, **42** (1920), 2049.

<sup>2</sup> Cf. M. FISCHER, *J. Am. Chem. Soc.*, **40** (1918), 303; R. H. BOGUE, *J. Ind. Eng. Chem.*, **14** (1922), 32.

<sup>3</sup> WINKELBLECH, *Z. angew. Chem.*, **19** (1906), 1953.



film. He could just detect as small an amount as 0.06 mg. of gelatin in 10 c.c. of water in this way, and suggested the application of the procedure for the estimation of gelatin. From a study of this paper Bancroft<sup>1</sup> concludes that it furnishes proof that an interfacial substance (a substance which tends to pass into the dineric interface of any two liquids) may be separated from its suspension in one liquid by shaking with another liquid in which it is interfacial. That is, gelatin, in suspension in water, may be separated from the water by shaking with a hydrocarbon, such as benzene, in which case the gelatin will become concentrated in the interfacial film.

*The Breaking of Emulsions.*—The breaking of an emulsion necessarily involves the reverse of the processes making for stabilization. The most apparent means would be the destruction in some way of the efficacy of the emulsifying agent. If the tenuous interfacial film of Pickering and Bancroft is dissolved or otherwise destroyed the emulsion will of course break. If the hydrophilic colloid of Fischer is diluted beyond the point where it is able to take all the water offered, or is so influenced by external conditions that its original capacity for holding water is sufficiently reduced, then the emulsion will break. Dehydration by the addition of a salt is often effective. Thomas<sup>2</sup> suggests seven methods by which emulsions may perhaps be broken:

1. Addition of excess of dispersed phase.
2. Addition of a liquid in which the two liquids phases are soluble.
3. Destruction of the emulsifying agent.
4. Filtration.
5. Heating.
6. Freezing.
7. Electrolyzing.

<sup>1</sup> W. D. BANCROFT, *J. Phys. Chem.*, **19** (1915), 297.

<sup>2</sup> A. W. THOMAS, *J. Ind. Eng. Chem.*, **12** (1920), 177.



## CHAPTER V

### GELATIN AS AN AMPHOTERIC COLLOID

The behavior of the proteins contradicts the idea that the chemistry of colloids differs from the chemistry of crystalloids.

Jacques Loeb (1920).

	PAGE
I. The Amphoteric Character of the Proteins.....	219
1. The Significance of Amphoterism.....	219
2. Amphoterism in the Proteins.....	221
3. The Mechanism of Protein-salt Formation.....	223
4. The Theories of Protein Ionization.....	225
5. The Electrolysis and Electrophoresis of Proteins.....	227
6. The Combining Capacity of Proteins.....	229
7. Hydrolytic Dissociation of Protein Salts.....	232
8. The Dominant Influence of the Dibasic and Diacid Protein Radicals in Ionization.....	234
9. Recapitulation.....	235
II. The Effect of Inorganic Ionogens upon Proteins.....	236
1. Precipitation and Coagulation.....	236
2. Robertson's Theory of Protein-salt Formation.....	239
3. Objections to Robertson's Theory of Protein-salt Formation..	241
4. Ion Series in Protein Precipitation, Swelling, etc.....	243
5. Applications of the Laws of Classical Chemistry to the Protein-salt Equilibrium.....	245
6. The Isoelectric Point of Gelatin.....	246
7. Loeb's Method for the Study of the Gelatin-salt Equilibrium..	247
8. Gelatin Salts and Metal Gelatinates.....	248
9. The Influence of Valency upon Protein-salt Formation.....	253
10. The Depressing Action of Salts.....	260
11. The Micelle Theory of McBain.....	264

#### I. THE AMPHOTERIC CHARACTER OF THE PROTEINS

**1. The Significance of Amphoterism.**—Whenever any chemical substance is capable of reacting with an acid, with the formation of a salt, it follows that the substance contains basic groups susceptible of neutralization, and if it reacts with a base, acid groups must be present. But a large number of substances are capable of exhibiting either basic or acidic properties depending upon the conditions to which they are subjected. Probably

all of the oxygen acids are of this class.<sup>1</sup> Aluminum hydroxide may be cited as typical. This substance is nearly insoluble in water, but readily dissolves in acids to form an aluminum salt, and in bases to form a metal aluminate. The ionization equilibrium is represented as follows:

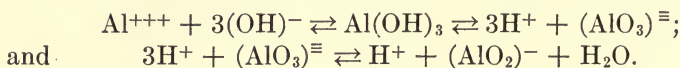

The term *amphoteric* was given by Bredig<sup>2</sup> to all substances possessing this power of combination with the ions of either an acid or a base.

The action of the acid or the base upon amphoteric substances of this type is very simply explained by the *law of mass action*, and *solubility product*, of Guldberg and Waage.

According to the law of mass action,

$$\frac{[\text{Al}^{+++}] \times [\text{OH}^-]^3}{[\text{Al}(\text{OH})_3]} = K_b,$$

and

$$\frac{[\text{H}^+]^3 \times [\text{AlO}_3^{\equiv}]}{[\text{Al}(\text{OH})_3]} = K_a,$$

where  $K_b$  is the ionization constant for the basic ionization of the aluminum hydroxide, and  $K_a$  the ionization constant for the acid ionization of the same. The brackets signify concentrations in all cases. So long as the aluminum hydroxide is present in solid form, the amount of this substance in solution will be constant, depending upon its solubility at that temperature, and, therefore, the product of the concentration of the  $\text{Al}^{+++}$  ions and the concentration of the  $(\text{OH}^-)^3$  ions will be a constant. But if now an acid is added the concentration of the hydroxyl ions must be greatly reduced, for, by the same law

$$[\text{H}^+] \times [\text{OH}^-] = K_w,$$

the ionization constant for water, and any increase in hydrogen ions must therefore result in a decrease in the hydroxyl ions in order that their product may remain constant. But as the hydroxyl ions decrease, more aluminum ions must be produced in order that  $[\text{Al}^{+++}] \times [\text{OH}^-]^3$  remain constant. This can take place only through the dissociation of more aluminum hydroxide,

<sup>1</sup> J. STIEGLITZ, "Qualitative Chemical Analysis," New York (1916), vol. 1, p. 175.

<sup>2</sup> G. BREDIG, Z. *Electrochem.*, 6 (1899), 33.

and upon continuing the process the latter must eventually be brought entirely into solution.

The addition of a base would, in an entirely similar way, depress the hydrogen ions, and result in an increase in the aluminate ions which would likewise result in solution of the aluminum hydroxide.

This same type of amphoteresis is found in the organic acids, as shown for example in the ability of acetic acid to substitute either the hydrogen or the hydroxyl of its carboxyl group:

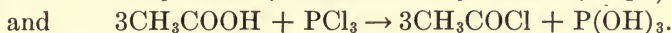
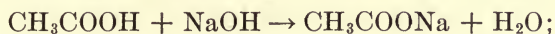

**2. Amphoteresis in the Proteins.**—A different condition is encountered however in certain organic compounds, wherein the basic and the acidic properties emanate from distinctly different groups within the molecule. As typical of this latter class the amino-acids are most important. The  $-\text{NH}_2$  group is distinctly basic and will combine readily with acids, while the  $-\text{COOH}$  group is the common organic acid group, and combines with bases. Thus in amino acetic acid or glycine:

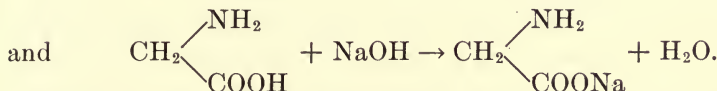
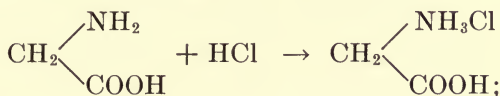

We know that proteins are made up of many amino-acids and if it could be shown that each of these constituent acids carried its amino and carboxyl in an uncombined state, as in the simple acid illustrated, then no further explanation would be required to account for the amphoteric behavior of the proteins. Van Slyke and Birchard<sup>1</sup> have pointed out however that only a very small portion of the total nitrogen of proteins is present in the free condition. They report the following data:

TABLE 38.—PERCENTAGE OF TOTAL NITROGEN PRESENT IN FREE AMINO GROUPS

Hæmoglobin .....	6.0	Edestin.....	1.8
Casein.....	5.5	Gliadin.....	1.1
Hæmocyanin .....	4.3	Zein.....	0.0
Gelatin.....	3.1		

<sup>1</sup> D. D. VAN SLYKE and F. J. BIRCHARD, *J. Biol. Chem.*, **16** (1913), 539.

After a complete hydrolysis, however, in which process the acids are liberated from their combinations, the nitrogen present in free amino groups ranges from 60 to 80 per cent of the total nitrogen.

As acids combine with the proteins in much greater proportion than is represented by the figures in the table, it is obvious that still other groups beside the free amino radicals are capable of reaction with acids. In fact Van Slyke and Birchard have shown that the free amino nitrogen in proteins corresponds exactly to one half of the nitrogen represented by the lysine alone that is present. Lysine contains an  $\alpha$  and an  $\omega$  amino group, and as the time required for the latter to interact with nitrous acid (30 minutes) is the same as that required by the protein, but is much longer than is taken by the  $\alpha$  group (3 minutes), it seems highly probable that the free amino nitrogen of an unaltered protein is attributable only to the  $\omega$  amino nitrogen of lysine. Zein, which contains no lysine, yields no amino nitrogen with nitrous acid. Any hydrolysis will however result in the formation of amino-acids, and then all  $\alpha$  groups as well as some others will become free and respond to the nitrous acid reaction.

Inasmuch as the amino groups are very readily attacked by nitrous acid when in the form of  $-\text{NH}_2$ , but are not affected while in the protein molecule, it follows that they must be in some kind of combination in the latter. The exact manner in which combination is effected is a question that has long been a subject of speculation. The most commonly accepted type is that of a simple condensation between the amino group of one acid and the carboxyl group of another. In this manner the peptid glycylglycine is formed from the condensation of two molecules of glycine:

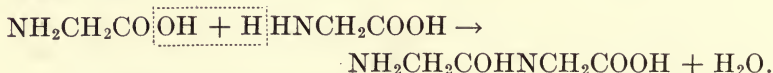

The peptids and polypeptids are therefore essentially amino-acids, and are capable of reacting with acids or bases through their terminal amino and carboxyl groups respectively. But as previously stated such reaction is not confined to these groups.

This has been demonstrated in a number of ways. Vernon<sup>1</sup> showed that the capacity of a hydrolyzed protein to neutralize bases was only slightly greater than that of the unaltered protein.

<sup>1</sup> H. M. VERNON, *J. Physiol.*, **31** (1904), 346.



and Blasel and Matula<sup>1</sup> and Pauli and Hirschfeld<sup>2</sup> have prepared deaminized gelatin by allowing nitrous acid to react with the protein, and found that acids combined with the product to nearly the same degree as with the untreated gelatin. As there can be no terminal amino groups in the deaminized product, it is obvious that the acid reacts with some internal groups. And as the internal —COHN— groups are transformed upon hydrolysis to —COOH and —NH<sub>2</sub> groups with no marked increase in basic or acidic combining capacity it seems probable that the —COHN— groups also are capable of neutralization, and responsible for the reactivity of the proteins with electrolytes.

Many other investigations make it imperative that this conclusion be accepted. Osborne<sup>3</sup> has shown that edestin combines with acids in such proportion that a very large percentage of its neutralizing power must be derived from other than free —NH<sub>2</sub> groups. Osborne and Leavenworth<sup>4</sup> found that edestin combines with cupric hydroxide in exact proportion to the amount of —COHN— groups which are present in the unaltered edestin molecule.

**3. The Mechanism of Protein-salt Formation.**—An hypothesis for the mechanism of the reaction by which the —COHN— groups may react with acids and bases has been postulated by Robertson.<sup>5</sup> He points out that both a keto and an enol form of that group may exist, as

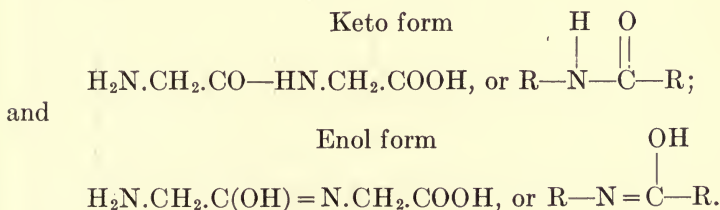

Of these the latter is much the more probable as it permits of a combination with either acids or bases, while the former may conceivably neutralize only acids.

<sup>1</sup> L. BLASEL and J. MATULA, *Biochem. Z.*, **58** (1914), 417.

<sup>2</sup> W. PAULI and M. HERSCHFELD, *ibid.*, **62** (1914), 245.

<sup>3</sup> T. B. OSBORNE, *J. Am. Chem. Soc.*, **24** (1902), 39.

<sup>4</sup> T. B. OSBORNE and C. S. LEAVENWORTH, *J. Biol. Chem.*, **28** (1916), 109.

<sup>5</sup> T. B. ROBERTSON, "The Physical Chemistry of the Proteins," N. Y. (1918), 24–31.

The enol form may react, according to Robertson, with acids or bases in the following ways:

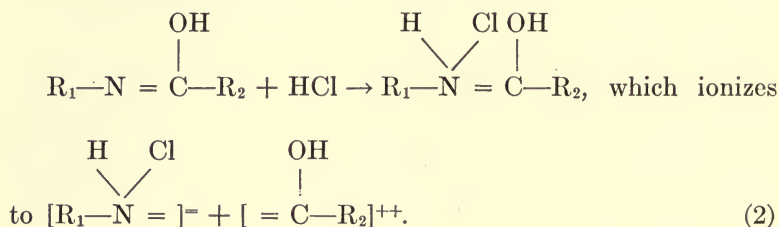
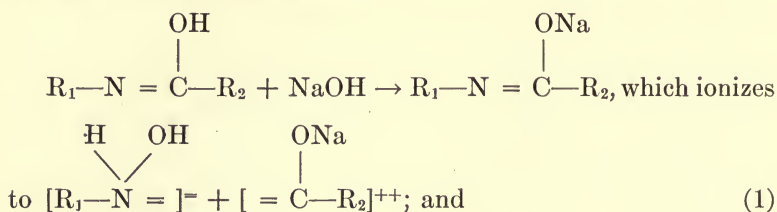

The possible combinations with the *diamino* acids is increased as follows:

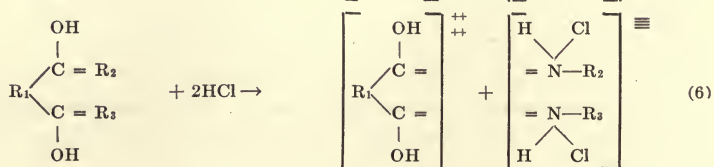
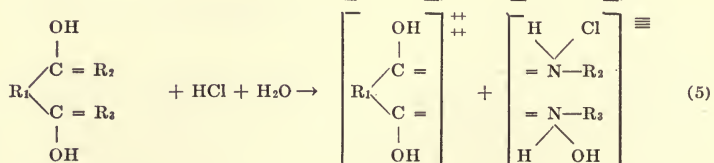
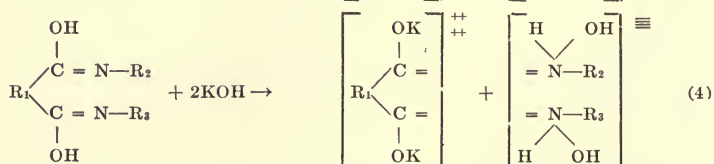
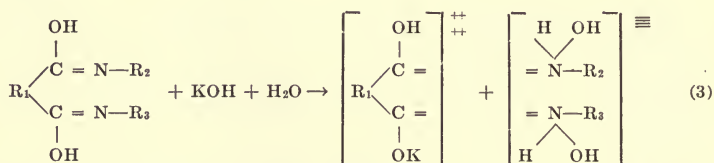

Of these, number (3) is not known to exist, but all of the other types are believed to have been observed.

Owing to the presence of both a positive and a negative group in the same molecule it is conceivable that these may neutralize each other, forming an internal salt:

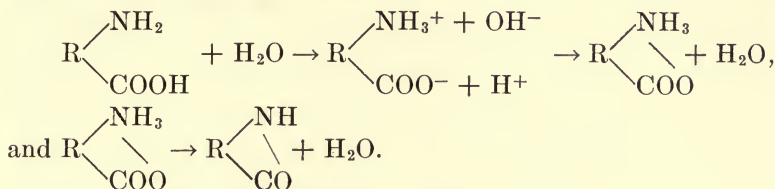

It may also happen that in the combination of two amino-acids interaction may take place between both of the acid and basic groups of both acids, also resulting in a ring compound:

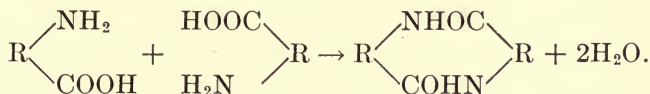

Still other possible combinations have been suggested, but those listed above cover the more important known cases.

Schryver<sup>1</sup> has suggested that the difference in the solubility and other properties between the globulins and the albumins may lie in the relative position of the reactive carboxyl and amino groups in the molecule. When the steric structure of the molecule is such that the above mentioned groups may react with each other to form internal anhydrides, such as are described above, and as is known to be possible in most amino-acids, then the resulting molecule is water soluble, and belongs to the albumin class. When, however, the structure does not permit of such anhydride formation, then reaction occurs between the amino group of one molecule and the carboxyl group of another molecule, with the formation of a compound of doubled molecular weight. This is insoluble, and belongs to the globulin class.

**4. The Theories of Protein Ionization.**—It is of special significance to observe that in his depiction of the mechanism of the ionization of proteins Robertson regards the ionic separation as occurring between two parts of the protein molecule rather than between protein on the one hand and the inorganic cation or

<sup>1</sup> S. B. SCHRYVER, *Proc. Roy. Soc. (London)*, **83** (1910), 96; *Kolloid-Z.*, **8** (1911), 233.

anion on the other. This view is in the nature of a departure from that which had previously been believed to obtain in protein ionization, but has been regarded by its champions as a necessary step in the evolution of our introspective knowledge of proteins. So long as it was acceded that neutralization occurred only at the terminal amino or carboxyl groups of the catenary molecule, it was necessary to grant, *a priori*, that the ionic break should take place at the same point:

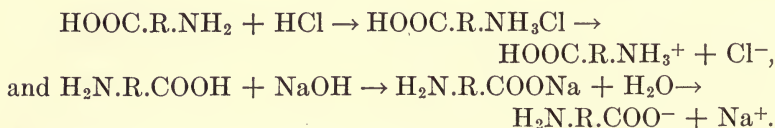

But with the accumulation of data which proved both directly and indirectly that interaction with acids and bases was not confined to the terminal amino and carboxyl groups, but was even more evident with the internal  $\text{—COHN—}$  groups, it became necessary for investigators to turn their attention more analytically upon the point of ionic rupture. As a result Robertson<sup>1</sup> has accumulated a number of experiments both by himself and other workers which in his belief leave little occasion for further doubt upon this point.

Bugarsky and Liebermann<sup>2</sup> have shown by potentiometric means that "the number of  $\text{Cl}^-$  ions bound by a given mass of protein dissolved in dilute hydrochloric acid is exactly equal to the number of  $\text{H}^+$  ions which it binds."

Oryng and Pauli<sup>3</sup> observed that gelatin, both normal and deaminized, in solution in potassium chloride, combined with a definite proportion of  $\text{Cl}^-$  ions, and that this amount was increased greatly upon the addition of acids.

Blasel and Matula<sup>4</sup> found that deaminized gelatin retained the power of binding  $\text{Cl}^-$  ions from solutions of hydrochloric acid despite the absence of the terminal amino groups.

Robertson has prepared caseinates of the alkalies and alkaline earths that are neutral or even acid to litmus, but finds nevertheless that these caseinates, which can contain no free base, are still excellent conductors of electricity, a neutral solution, for example,

<sup>1</sup> T. B. ROBERTSON, *lib. cit.*, 167.

<sup>2</sup> S. BUGARSKY and L. LIEBERMANN, *Arch. ges. Physiol.*, **72** (1898), 51.

<sup>3</sup> T. ORYNG and W. PAULI, *Biochem. Z.*, **70** (1915), 368.

<sup>4</sup> L. BLASEL and J. MATULA, *ibid.*, **58** (1914), 417.



showing a conductivity of  $92.7 \times 10^{-3}$  reciprocal ohms per equivalent of base neutralized at  $30^{\circ}\text{C}$ . In another experiment Robertson finds that the conductivity of the potassium caseinate *alone*, in solution of potassium chloride of varying concentration from 0 to 0.3 N, is constant within the limits of accuracy of the experiment. Obviously, if dissociation occurred between the casein on the one hand, and the potassium on the other, a decided increase in conductivity must result as more potassium is introduced into the molecule, and the constancy of the above data can be interpreted in no other way but that the ionization of the potassium caseinate does not yield potassium ions, or else (Fischer's view) that there is no ionization at all.

By employing data of Kohlrausch and Holborn,<sup>1</sup> Robertson has calculated the equivalent conductivity of a number of basic protein salts at infinite dilution and finds that in many cases this maximum value is smaller than the equivalent conductivity of the inorganic ion alone. Now if dissociation took place between the protein and the inorganic radical, then the maximum conductivity must be the sum of the equivalent conductivity of the inorganic ion and that of the protein ion. It must in all cases therefore be greater than the conductivity of the inorganic ion by a quantity representative of the conductivity of the protein ion. Since however it is found in many cases to be less, the inference is that dissociation cannot have taken place in the manner postulated, *i.e.*, between protein and inorganic ion, but must rather have been between two portions of the protein itself.

**5. The Electrolysis and Electrophoresis of Proteins.**—Many experiments have demonstrated that certain proteins appear to migrate, under the influence of the electric current, towards the cathode or towards the anode, depending upon the condition of solution of the protein. Thus Hardy<sup>2</sup> has shown that dialyzed egg albumin migrated under electrical tension to the cathode if a little acid was present, and to the anode if alkali was present. Similar results have been obtained with gelatin and a number of other proteins, the only difference noted being in the exact degree of acidity or alkalinity required to bring about a given migration.

The fact that the protein appears to move as a whole and,

<sup>1</sup> F. KOHLRAUSCH and L. HOLBORN, "Das Leitvermögen der Electrolyte," Leipzig (1898).

<sup>2</sup> W. B. HARDY, *J. Physiol.*, **24** (1899), 288; **33** (1905), 286.

under a given set of conditions, in one direction only, suggests a refutation of Robertson's theories above cited, but Robertson explains the observation as being apparent rather than real. According to his views the protein should split, a part migrating towards the cathode and a part towards the anode regardless of the state of acidity or alkalinity of the solution. He further maintains that this is, in fact, what happens, but that the different types of change taking place at the electrodes makes it appear as if the migration were in one direction only. Thus, for example, free uncombined protein is insoluble. In the electrolysis of a protein dissolved in a base the anion, after migrating to the anode and neutralizing any base that may be present, will be precipitated as insoluble protein. The cation, on the other hand, would carry to the cathode an excess of base and, as protein is soluble in alkaline solutions, precipitation could not occur. Similarly, in the presence of an acid, the free uncombined protein must be precipitated at the cathode, but not at the anode, as at the latter point an excess of acid would result in its solution.

In another experiment Robertson shows that the loss of casein from the anodal region of an alkaline solution of casein is, upon electrolysis for 2 hours at 30°, about twice as great as that from the cathodal region, while if the cations consisted of potassium ions the loss in casein from the anodal region would be at least four times that from the cathodal region, since the equivalent velocity of the potassium ions is at least four times that of the more cumbersome casein ions.

Objection is raised to Robertson's views of ionization by Pauli, Samec, and Strauss<sup>1</sup> upon the ground that (1) the hypothesis involves the dissociation of proteins into groups that are not known to have an *ex parte* existence; (2) electrophoresis experiments reveal the presence of but one protein ion; and (3) under certain conditions the H<sup>+</sup> and Cl<sup>-</sup> ions may be bound in unequal proportions by proteins in hydrochloric acid solution.

The previous discussion has for the most part expressed Robertson's views upon these objections. He urges that the first point is beside the question, for the ions of common inorganic electrolytes are likewise incapable of existence when separated from the electrical field in which they are found. He recalls, in answer to the second point, that Stirling and Brito<sup>2</sup> have obtained

<sup>1</sup> PAULI, SAMEC, and STRAUSS, *Biochem. Z.*, **59** (1914), 470.

<sup>2</sup> STIRLING and BRITO, *J. Anat. Physiol.*, **16** (1882), 446.

a simultaneous deposition of crystals of haemoglobin at both electrodes by the passage of a direct current through the solution, and that Howell<sup>1</sup> has obtained, with fibrinogen, an increase in concentration at both poles. That an inequality in the binding of  $\text{Cl}^-$  and  $\text{H}^+$  ions may occur is taken to signify only a difference in affinity of the nitrogen atom for the respective ions of the hydrochloric acid. This difference seems to be dependent upon the proportion of hydrochloric acid to protein, and not at all upon the dilution of the system.

Robertson raises a further objection to his hypothesis based upon the unprecedented breaking of a double bond between a carbon and a nitrogen atom in the process of ionization. He answers it however by calling attention to the findings of Gomberg<sup>2</sup> that "the precise point within a molecule at which ionization may occur is determined by the strains to which the molecule is subjected, and that when the strain is unusually great the break involved in ionization may occur at points which resist the tension due to strains of normal magnitude." He concludes with the very pertinent argument that "the additional strains which a molecule of acid or base introduces into the molecule are not merely those commensurate with and attributable to its weight, but also strains of electrostatic origin, since the salt which is formed unquestionably undergoes ionization. It may very possibly be true that the first step in salt formation consists in the neutralization of end  $-\text{NH}_2$  or  $-\text{COOH}$  groups, but that the ionization of the compound formed, leading to the development of electrostatic tension at the very places at which it must exert the greatest strain, namely the extremities of the molecule, results in the splitting of the otherwise stable linkage

$\begin{array}{c} | \\ -\text{C}=\text{N}- \end{array}$  and the redistribution of the components of the molecule and the strains to which it is subjected."<sup>3</sup>

**6. The Combining Capacity of Proteins.**—A measurement of the exact combining capacity of proteins for acids and bases is a subject that presents many technical difficulties. A few salient facts have however been observed. Pauli and Hirschfeld<sup>4</sup> studied the combining capacities of normal and deaminized gelatin (in

<sup>1</sup> HOWELL, *Am. J. Physiol.*, **40** (1916), 526.

<sup>2</sup> M. GOMBERG, *J. Ind. Eng. Chem.*, **6** (1914), 33.

<sup>3</sup> T. B. ROBERTSON, *lib. cit.*, 192.

<sup>4</sup> W. PAULI and M. HIRSCHFELD, *Biochem. Z.*, **62** (1914), 245.



addition to several other proteins) for acids by electrometric determination of the hydrogen ion concentrations<sup>1</sup> in the presence of varying amounts of the acids. They found that the extent of dilution of the system had no material effect upon the maximum combining capacity, but that the amount of acid bound depended rather upon the ratio of acid to protein. It is especially significant that, for a given amount of gelatin, the percentage of *bound*

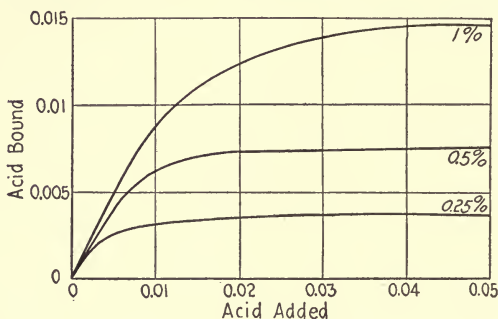

FIG. 33.—Relation between acid added and acid bound. (Pauli and Hirschfeld.)

acid increases as the amount of acid actually present increases. This is well shown by Fig. 33, taken from the above mentioned report.

Similar results have been obtained by Robertson<sup>2</sup> with casein in solution with potassium hydroxide. He finds that potassium hydroxide combines with casein in increasing amount as the ratio of the alkali to the casein in the system increases. By interpolating from his data he postulates that a least five different compounds of the base with the casein are capable of existence, and that with the addition of each equivalent of potassium hydroxide a new set of —COHN— groups opens up in ionization. Thus, in the first reaction, the casein molecule is broken into two ions by the introduction of one equivalent ( $11.4 \times 10^{-5}$  equivalents of KOH per gram of casein) of the base. A second portion breaks these into four ions, and so on until at the maximum combining capacity 16 equivalents of the base have been added, and 16 —COHN— groups have been opened up.

This same process is ascribed to the ionization of all proteins. In proteins that are soluble it is not possible to obtain directly

<sup>1</sup> The determination of hydrogen ion concentration by electrometric means is discussed in the Appendix.

<sup>2</sup> T. B. ROBERTSON, *lib. cit.*, 195.



the minimum equivalent of a base or acid that will produce the first ionic break in the molecule, but the general similarity in the action of the several proteins makes it seem probable that the nature of ionization is the same in all cases.

The equilibrium between gelatin and acids and bases has been studied in some detail by Miss Lloyd.<sup>1</sup> She found that the degree of swelling varied with the ratio dry weight of gelatin to volume of 0.001N HCl where only the volume was a variable. She incorrectly ascribes this to the mass relation. The significant reason for the variation in swelling probably lies in the alteration in the pH of the solution. The smaller the volume of solution the less the total hydrogen ions present, and the more rapidly will the pH change with time. The swelling is defined in this instance by the pH.

Miss Lloyd found further that gelatin would dissolve completely, in the course of a few days, in solutions of hydrochloric acid and of sodium hydroxide that were 0.01N or stronger; the more rapidly on the alkaline side, but with the greater preliminary swelling on the acid side. The gelatin chloride reaction was found to differ fundamentally from the sodium gelatinate reaction, however, in that the former was reversible while the latter was not. This was demonstrated by the following procedure. The gelatin chloride solution was neutralized, the gelatin precipitated with saturated ammonium sulphate or alcohol, dissolved in water and allowed to stand in the cold. A gel was produced possessing all of the properties of the original gelatin gel. A similar treatment of the sodium gelatinate gave a solution which would not gel upon cooling. Miss Lloyd accounts for the difference on the ground of some structure alteration, as actual degradation of the molecule was shown not to have occurred. (No differences were observed between the free amino-acid and free ammonia content of a solution in sodium hydroxide and one in water.) She regards it as probable that under the action of acids gelatin goes to the keto-form, and under the action of bases to the enol-form. "This would conform with the observation that the free acid from sodium gelatinate differs in properties from the free base of gelatin hydrochloride.

By assuming a molecular weight for gelatin of about 10,000, Miss Lloyd finds that the basicity of gelatin at a pH of 2.5 (at which point gelatin appears to be completely neutralized by

<sup>1</sup> D. J. LLOYD, *Biochem. J.*, **14** (1920), 147.

hydrochloric acid) is 8 while at a pH of 13 (at which point the acid valencies are satisfied) the acidity is 28. By employing Berrar's figures the latter value is reduced to 13.

**7. Hydrolytic Dissociation of Protein Salts.**—It seems to have been a rather generally accepted view that the salts of gelatin and the other proteins with inorganic cations or anions were easily dissociated hydrolytically with water. In fact the mass law of Guldberg and Waage would demand that such should be the case provided that ionization took place between the organic complex on the one hand and the inorganic ion on the other. That is, if the protein reacted with a base according to the equation:

$$\text{H}_2\text{N} \cdot \text{R} \cdot \text{COOH} + \text{KOH} \rightarrow \text{H}_2\text{N} \cdot \text{R} \cdot \text{COO}^- + \text{K}^+ + \text{H}_2\text{O},$$

or with an acid according to the equation:

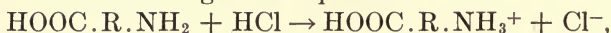

then hydrolytic dissociation would be expected to follow. This is obvious, for the inorganic base or acid is in each case highly ionized while the organic acid or base, that is, the uncombined protein, is very weak and but feebly ionized. In the presence, therefore, of an excess of water the undissociated protein molecule would tend to be produced to the ever increasing exclusion of the ionized moiety. In other words, the actual percentage of combined inorganic cation or anion would steadily and rapidly decrease with increasing dilution. That such a decrease does not take place is indicated however by the findings of some investigators. The percentage of combined base or acid is uninfluenced, within the limits of experimental error, by dilution, but is determined by the relative concentration of protein and inorganic ion. This may be interpreted to signify that ionization cannot take place in the manner just illustrated, but must be independent of the elements of water. In accordance with the hypothesis of intramolecular ionization:

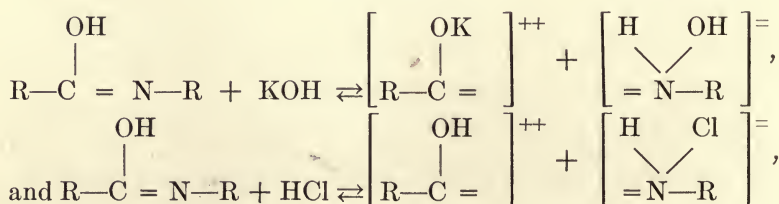

no water enters into the reaction, and consequently water would be without influence on ionization upon dilution of the system. Robertson regards this evidence, *i.e.*, the non-dependence of the composition of protein salts upon their dilution, as of the greatest importance in proving that the terminal  $-\text{COOH}$  and  $-\text{NH}_2$  groups are not responsible for the formation of such salts.

Theoretical evidence of the independence of the composition of protein salts upon the dilution is obtained in the case of a number of proteins by the application of the Ostwald dilution law for binary electrolytes. Robertson<sup>1</sup> writes the equation:

$$m = Ax + Bx^2,$$

where  $m$  is the equivalent concentration of the base or acid bound by the protein,  $x$ , the specific conductivity in reciprocal ohms, and  $A$  and  $B$  constants, respectively equal to:

$$\frac{1.037 \times 10^{-2}}{\rho(u + v)} \quad \text{and} \quad \frac{1.075 \times 10^{-4}}{K\rho(u + v)^2},$$

in which  $\rho$  is the number of equivalents of protein salt to which each equivalent of neutralized acid or base gives rise, and  $u$  and  $v$  are average equivalent migration velocities in centimeters per second under unit potential gradient, of the cations and anions respectively.  $K$  is the dissociation constant. On applying the above formula to a number of proteins under a number of different conditions, the observed and the calculated values of  $m$  are found to be in very close agreement, which shows that, "for a given combination of acid or base with protein, containing a given proportion of the acid or base, the number of equivalents of protein salt to which one equivalent of neutralized acid or base gives rise is independent of the dilution."

By further applying the formula to compounds of the diacid bases it is found that the ratio of the value of  $\rho(u + v)$  for monacid bases to its value for diacid bases is very close to 2:1. This is shown to signify that an equivalent of a monacid base gives rise to twice the number of equivalents of protein salt as an equivalent of a diacid base. It has been pointed out that one equivalent of a monacid base yields, on combination with protein, two equivalents of the protein salt, according to the equation:

<sup>1</sup> T. B. ROBERTSON, *lib. cit.*, 220.

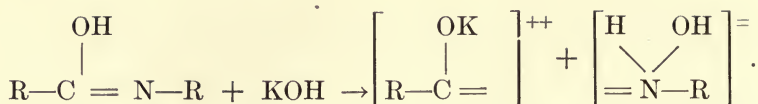

If the diacid bases reacted in a similar manner we should expect the equation to be as follows:

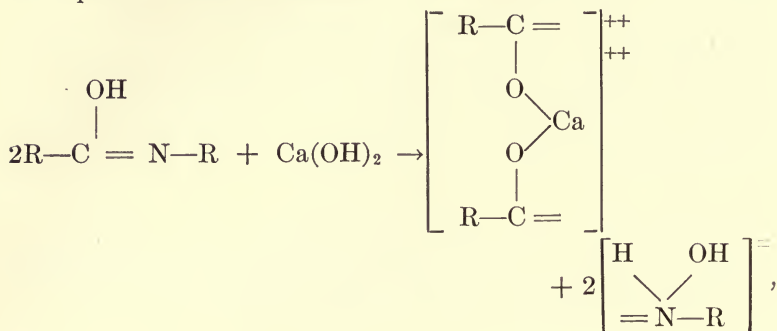

in which case one equivalent of the diacid base would also give rise to two equivalents of the protein salt. The data above referred to show that this cannot be the case, and an internal neutralization may be assumed of two of the positive and two of the negative valencies forming ions of the type:

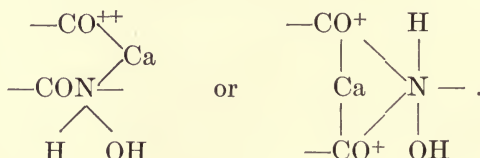

This necessitates the assumption that the ions produced by the alkaline earths are twice the weight of those produced by the alkalis with proteins. In this connection it is worthy of notice that differences in the properties of these two types of protein salts have been observed by Loeb and others which also tend to confirm this conclusion.<sup>1</sup>

**8. The Dominant Influence of the Dibasic and Diacid Protein Radicals in Ionization.**—Evidence is also available which tends to indicate that the diamino radicals and the dicarboxylic acid radicals present in the proteins are the active agents in accomplishing salt formation with acids and with bases respectively.<sup>2</sup>

<sup>1</sup> For example, a greater insolubility of such salts.

<sup>2</sup> A. KOSSEL, *Z. physiol. Chem.*, **25** (1898), 165.



For example the freezing point of solutions of casein in a base is unaltered by varying the concentration of the casein, provided the amount of base present is constant. That is, a given quantity of a base always gives rise to the same number of protein ions, whether the base is combined with more or with less protein. It must follow that each molecule of alkali gives rise to one ion of the protein. If the reaction were concerned with only one —CO—HN— group, *i.e.*, a monocarboxylic acid, one molecule of the mono-acid base would give two protein ions, as:

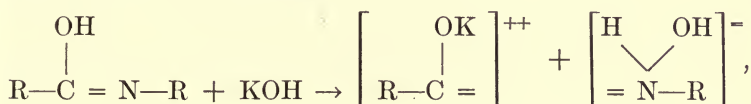

but if a dicarboxylic acid were involved, the number of protein ions would be identical with the molecules of base added, as

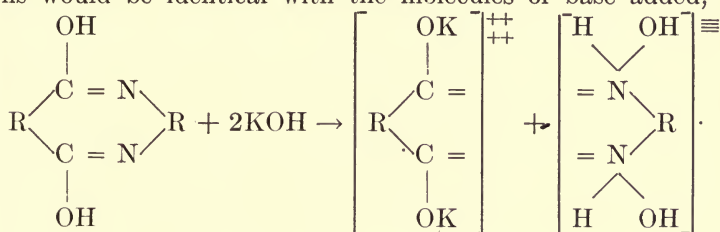

Similarly, the freezing point of ovomucoid appears to be unaltered by varying the amount of acid (hydrochloric) added, and consequently the number of ions per unit volume of the system is unchanged. The relation between the number of molecules of acid added, and the number of ions formed is also found to be in the ratio of 1:1 in the case of salmin. These data find expression in Robertson's scheme of ionization as follows:

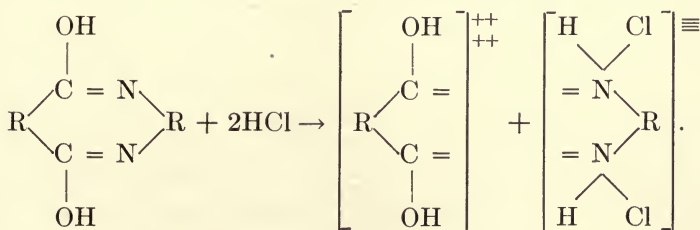

**9. Recapitulation.**—To summarize the preceding section of this chapter, evidence has been presented which indicates that:

1. Proteins are amphoteric compounds capable of combining with either acids or bases to form protein salts. The salts thus formed yield, in water, true or colloidal solutions which contain ions, together with nonionized hydrated colloid aggregates.

2. Ionization of these salts takes place, not primarily between the protein and the inorganic ion by a reaction with terminal  $-\text{NH}_2$  or  $-\text{COOH}$  groups, but between nearly equal portions of the protein molecule, by a break in the internal  $-\text{COHN}-$  groups.

3. Protein salts are relatively stable and not easily, or but slowly, dissociated hydrolytically.

4. The extent of salt formation is determined by the relative proportions of acid or base present, and but little by the degree of dilution of the system.

5. An equivalent of a monoacid base yields twice the number of equivalents of a protein salt as an equivalent of a diacid base.

6. Successive additions of acid or base to a protein open up additional  $-\text{COHN}-$  groups situated at or near the centre of the molecules or ions reacted upon.

7. The ionization of the proteins takes place essentially at the points of union of the diamino and of the dicarboxylic acid groups.

## II. THE EFFECT OF INORGANIC IONOGENS UPON PROTEINS

1. **Precipitation and Coagulation.**—According to Hardy<sup>1</sup> and a number of later investigators the reaction resulting from the precipitation of a protein by a salt may be of two types. The first type is entirely similar to the reaction between solutions of two electrolytes wherein the product of the reaction is insoluble, such as the precipitation resulting from the interaction of solutions of sodium sulphate and barium chloride. The reaction involves a combination of ions with the formation of a sparingly soluble compound. Such a reaction may be illustrated by the interaction of gelatin and phosphotungstic acid, resulting in the formation of insoluble gelatin phosphotungstate. Representing the gelatin by A and the phosphotungstic radical by B the reaction may be expressed very simply:

<sup>1</sup> W. B. HARDY, *J. Physiol.*, **33** (1905), 251.

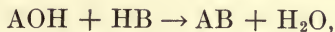

or perhaps more accurately,

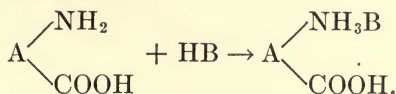

The reaction will obviously be subject to the limitations defined by the Mass Law and the formation of a precipitate in any case must be determined by the solubility product of the salt formed. That is, in any reaction such as:

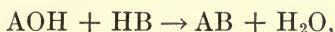

the ratios:

$$\frac{[\text{A}]^+ \times [\text{B}]^-}{[\text{AB}]} = K, \text{ and } \frac{[\text{AB}]_{\text{solution}}}{[\text{AB}]_{\text{solid}}} = K_1,$$

must obtain. Combining these we find, in a saturated solution at a given temperature:

$$[\text{A}]^+ \times [\text{B}]^- = K_{\text{solubility product}}.$$

If, now, the product of the above ion concentrations is made greater than the value of the solubility product constant for that substance, equilibrium can be maintained only by the precipitation of the undissociated salt. This means that a definite concentration of precipitant must be added to any protein at any temperature before precipitation will result, and the greater the insolubility of the resulting salt, the less the amount of precipitant required.

The other type of reaction by which inorganic salts may precipitate protein is of a nature that strongly suggests dehydration, as first suggested by Hofmeister in 1889-90. Jones and his pupils<sup>1</sup> have found that inorganic molecules and ions possess the power of forming hydrates or solvates in the presence of water, especially at low temperatures. At high temperatures these are decomposed.

G. M. Smith<sup>2</sup> showed that in the case of the alkali metals and the halogens the hydration increased in the order of decreasing ionic weight. The following table gives his figures at 0°C.

<sup>1</sup> H. C. JONES and K. OTA, *Am. Chem. J.*, **22** (1899), 5; H. C. JONES and H. S. UHLER, *ibid.*, **34** (1905), 291; H. C. JONES, *Z. physik. Chem.*, **74** (1910), 325.

<sup>2</sup> G. M. SMITH, *J. Am. Chem. Soc.*, **37** (1915), 729.

TABLE 39.—HYDRATION OF INORGANIC IONS

Ion	Ionic weight	Molecules of hydrated water	Ion	Ionic weight	Molecules of hydrated water
Cs .....	133	3.7	I.....	127	4.3
Rb.....	85	6.4	Br.....	80	6.7
K.....	39	9.6	NO <sub>3</sub> .....	62	8.9
Na.....	23	16.9	ClO <sub>3</sub> .....	83	9.3
Li.....	7	24.0	Cl.....	35	9.6

When more than one salt is present in the solution the various molecules or ions compete for the water, and if the latter is present in insufficient amount, each will take up the water in proportion to its solvate potential. In this respect the action is analogous to the distribution by differential solubility of a solute in two or more solvents.

There is an abundance of evidence leading to the belief that proteins are exceptional in their tendency to form solvation compounds with water. Since this is the case it would be expected that in solutions containing both proteins and inorganic salts there would exist a pronounced competition on the part of the two substances for the solvent. By increasing the relative proportion of salt to protein it is conceivable that the latter might be forced to give up water to the point where it would no longer be soluble in the solution, and precipitation would result.

It seems very doubtful however if this process ordinarily takes place to the exclusion of the one previously described. Taking gelatin as an example, it appears that magnesium sulphate may react in three ways. If the solution is alkaline, precipitation takes place only at high concentrations. If the solution is neutral, precipitation is more pronounced. If the solution is acid to a definite optimum, then precipitation reaches its maximum, but declines thereafter with further additions of acid. The explanation is probably as follows. In alkaline solutions magnesium gelatinate will be formed.<sup>1</sup> This is apparently sufficiently soluble in alkaline solutions so that a rather high concentration of the magnesium sulphate must be present in order to produce precipitation. This is finally brought about by two simultaneous processes. The available solvent is being removed by

<sup>1</sup> Vide later sections in this chapter.



increasing additions of the reagent, and the product of the concentration of the magnesium and the gelatin ions is as regularly increasing, until eventually it exceeds the solubility product for magnesium gelatin, and precipitation results.

The same procedure occurs in an acid medium except that the gelatin salt is, in this case, gelatin sulphate. Apparently the molecular solubility of this substance is less than that of the magnesium gelatin, for precipitation occurs at lower concentrations of the precipitant.<sup>1</sup>

The point of maximum precipitation appears to coincide with the isoelectric point of gelatin<sup>2</sup> which is found to be in a slightly acid medium at a pH of 4.7. In this condition the gelatin reacts with neither ion of the salt, and precipitation is brought about entirely by dehydration. Even in the absence of any electrolyte the isoelectric gelatin is sufficiently anhydrous to precipitate spontaneously at low temperatures.

It has been suggested that the two types of precipitation of proteins, as above described, be distinguished by the terms *precipitation* and *coagulation*, the former referring to the interaction between ions, and the latter to the production of an insoluble material through the agency of dehydration.

**2. Robertson's Theory of Protein-salt Formation.**—Robertson<sup>3</sup> regards the dehydration attendant upon coagulation as resulting in the formation of protein anhydrides. This reaction involves only the terminal  $-\text{NH}_2$  and  $-\text{COOH}$  groups, so that any combinations of the protein with inorganic anions or cations, since that combination is effected at the internal  $-\text{COHN}-$  groups, would not be affected by anhydride formation. The following types of anhydride formation may occur:

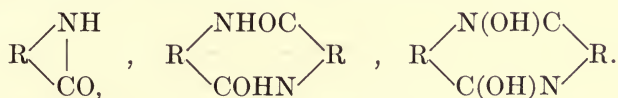

The mechanism of precipitation is accounted for by assuming that in a solution of an acid protein, the cation only of an added inorganic salt will enter into combination with the protein, liberating an acid, while, in a solution of an alkaline protein, both ions of the added salt enter into combination, liberating

<sup>1</sup> R. H. BOGUE, *Chem. Met. Eng.*, **23** (1920), 106.

<sup>2</sup> *Vide* Appendix.

<sup>3</sup> T. B. ROBERTSON, *lib. cit.*, 129.

only water. These reactions may be pictured by the following equations:

Acid protein plus salt

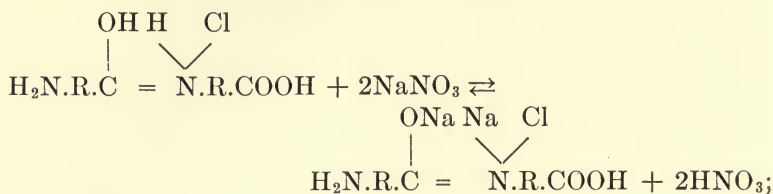

Alkaline protein plus salt

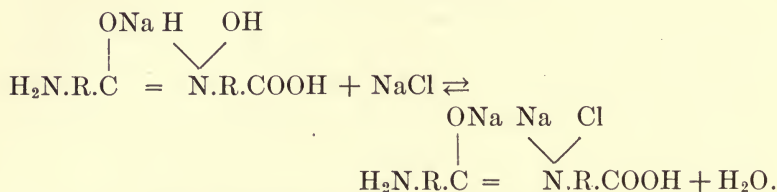

It will be observed that the same salt is formed in both cases. Internal neutralization may take place forming the compound:

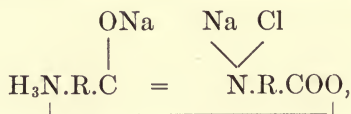

and in the presence of a large amount of water a certain degree of hydrolytic dissociation may occur:

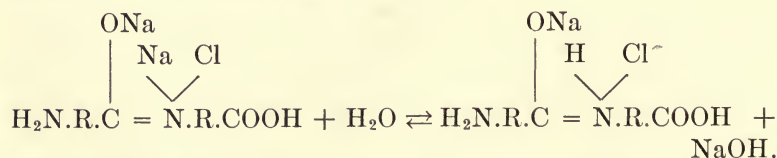

Robertson believes that the above explanation accounts for a number of experimental observations, among which may be cited the following:

1. The addition of neutral salts to an acid protein increases the acidity of the solution, while the addition of neutral salts to an alkaline protein does not increase the alkalinity of the solution.
2. Cations are responsible for the precipitation of acid-proteins, anions for alkali-proteins.
3. The precipitation of proteins by salts is more readily brought about in acid than in alkaline solutions.

**3. Objections to Robertson's Theory of Protein-salt Formation.**—In the light of the recent work of Loeb<sup>1</sup> however the hypothesis of Robertson does not appear to be, in all respects, adequate. Loeb has shown that an acid gelatin, in the presence, for example, of a solution of silver nitrate, will combine with the anion only, and that only the merest traces of the silver ion enter into combination. If, however, the gelatin is alkaline considerable portions of the silver ion become combined with the protein. According to Robertson's view the final product should be the same in both instances, and in both cases should contain the silver ion. His formula would be:

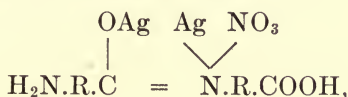

or the above salt in an ionized condition. That this is not the case has been demonstrated.

In another experiment sodium bromide was added to gelatin at different hydrogen ion concentrations, and in this case it was established that the acid gelatin combined with the anion in considerable proportions, while only traces of bromide were found combined with the alkali gelatin. Taken together these experiments show that acid-gelatin is capable of combination with the anions but not the cations of inorganic salt solutions, while alkali-gelatin is capable of combination with the cations, but not the anions of such solutions. These results are not in conformity with Robertson's hypothesis of the action of salts upon proteins.

Pauli<sup>2</sup> has suggested that the reaction between acid- and alkali-protein and inorganic salt solutions takes place according to the following equations:

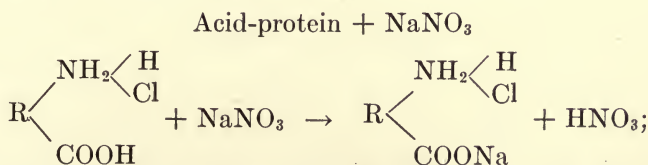

<sup>1</sup> JACQUES LOEB, *J. Gen. Physiol.*, **1** (1918-19), 39; 237; 363; 483; 559.

<sup>2</sup> W. PAULI and H. HANDOVSKY, *Biochem. Z.*, **18** (1909), 340; **24** (1910), 239; W. PAULI and R. WAGNER, *ibid.*, **27** (1910), 296.

Alkali-protein + KCl

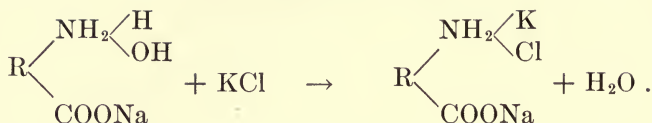

These equations are no more satisfactory in explaining the findings of Loeb than are those of Robertson, for they assume a combination between acid-gelatin and inorganic cation, and between alkali-gelatin and inorganic anion, which has been shown not to occur.

It seems probable that the reactions may be represented in conformity with all of the observed facts by the following equations:

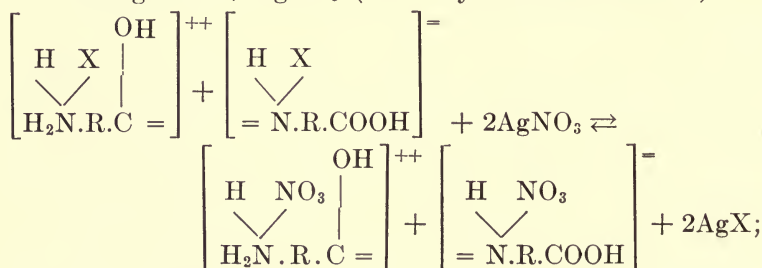
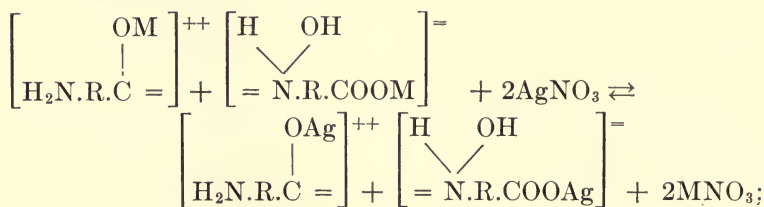
Acid-gelatin + AgNO<sub>3</sub> (X = any monovalent anion)Alkali-gelatin + AgNO<sub>3</sub> (M = any monovalent cation)

Acid-Gelatin + NaBr

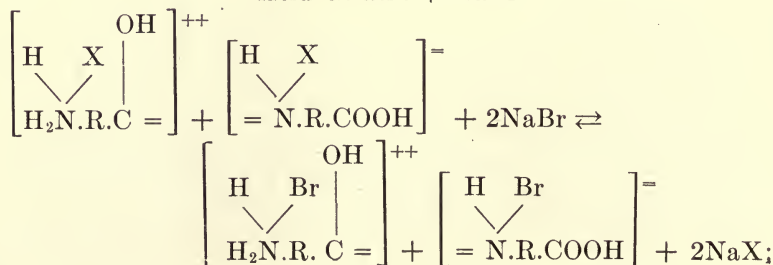



## Alkali-gelatin + NaBr

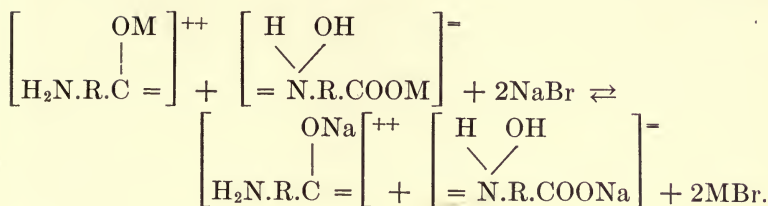

These equations, while fitting equally well with Robertson's reactions in his general scheme of protein ionization, account more satisfactorily for the facts observed in the interactions between proteins and inorganic salts than the formulas given by him. The observation that the acid-gelatin interacts only with the anions of an added salt, while the alkali-gelatin reacts only with the cations, is accounted for by these equations.

**4. Ion Series in Protein Precipitation, Swelling, etc.**—In 1888 Hofmeister<sup>1</sup> enunciated what has since come to be known as the Hofmeister series of ion reactivity with proteins. He studied a number of proteins and other colloids including gelatin, egg-albumin, serum-albumin, sodium oleate, and ferric hydroxide, and found that the order of influence of inorganic radicals upon them was approximately the same for each of the substances studied. Different inorganic ions behaved very differently, but their coagulating power or gelation effect upon proteins and other colloids was nearly always found to be in the same order.

Having established this uniformity of behavior of inorganic ions in the precipitation of proteins Hofmeister next proceeded to study the effect of similar ions upon the swelling of proteins. He found that the swelling of the different proteins was likewise affected in a similar sense by the inorganic radicals, and he arranged the series in the following sequence, beginning with the lowest degree of swelling: sulphates < citrates < tartrates < acetates < alcohol < cane sugar < grape sugar < distilled water < chlorides < chlorates < nitrates < bromides. This order was noted to be nearly identical with the order of efficacy of the salts in coagulation, the first three or four in the series being the most ready precipitants of the proteins.

<sup>1</sup> F. HOFMEISTER, *Arch. expl. Path. Pharm.*, **24** (1888), 247; **25** (1888), 1; **27** (1890), 395; **28** (1891), 210; *Z. physiol. Chem.*, **14** (1890), 165.

The researches of Hofmeister were continued by Pauli<sup>1</sup> who studied, in addition to the coagulation and the swelling of proteins, changes in their viscosity and the temperatures of their gelatinization and melting, as affected by inorganic ions. His results confirm those of Hofmeister by placing the order of the effect of ions upon the gelatinizing and melting points of gelatin parallel with their power of coagulating gelatin, and of inhibiting the swelling of gelatin plates. The anions of the salts were the most effective, but the cations were not without influence, and an ionic sequence was also recorded for them. The following table taken from Pauli expresses the results obtained with proteins:

TABLE 40.—EFFECT OF INORGANIC IONS ON PROPERTIES OF PROTEINS

Lowering of gelatinization point of gelatin (Pauli)	Increasing swelling effect on gelatin (Hofmeister)	Decreasing coagulating effect on gelatin (Pauli)	Increasing coagulating effect on egg globulin (Pauli)	Decreasing effect of acids on viscosity of blood serum (Pauli)
Sulphates	Sulphates	Sulphates	Ammonium	Hydrochloric
Citrates	Citrates	Citrates	Potassium	Monochloroacetic
Tartrates	Tartrates	Tartrates	Sodium	Oxalic
Acetates	Acetates	Acetates	Lithium	Dichloroacetic
Chlorides	Chlorides	Chlorides	Barium	Citric
Chlorates	Chlorates	.....	Magnesium	Acetic
Nitrates	Nitrates	.....	.....	Sulphuric
Bromides	Bromides	.....	.....	Trichloroacetic
Iodides	.....	.....	.....	.....

Mixtures of salts were observed to produce an effect equal to the algebraic sum of the individual effects resultant from the component ions represented.

The first researches tending to throw doubt upon the validity of the Hofmeister and Pauli series were performed by Posternak<sup>2</sup> in 1901. By employing a vegetable protein obtained from the seeds of *Picea excelsa*, he succeeded in demonstrating that the order of effectiveness of the inorganic ions in coagulating the protein in a slightly acid solution was exactly reversed in a slightly alkaline solution. The condition of acidity or alkalinity had not previously been considered. Pauli<sup>3</sup> soon verified these

<sup>1</sup> W. PAULI, *Arch. ges. Physiol.*, **71** (1898), 333; **78** (1899), 315; W. PAULI and P. RONA, *Beitr. physiol. path. Chem.*, **2** (1902), 1.

<sup>2</sup> S. POSTERNAK, *Ann. Inst. Pasteur*, **15** (1901), 85; 169; 451; 570.

<sup>3</sup> W. PAULI, *Beitr. physiol. path. Chem.*, **3** (1903), 225.

findings with egg-white and other proteins, and later investigators have confirmed their results. Ions which most strongly induce coagulation in an acid-protein are, in an alkali-protein, the least effective, while those ions that are nearly without influence in an acid-protein will, in an alkali-protein, be most effective.

**5. Application of the Laws of Classical Chemistry to the Protein-salt Equilibrium.**—The investigations of Loeb<sup>1</sup> constitute, however, the most emphatic argument against the validity of the Hofmeister-Pauli ion series. Loeb has long been a leader in the classical school of chemistry, and takes serious exception to the tendency of some of the modern investigators to explain the reactions which obtain in colloidal solutions as of a special type dependent upon adsorption, degree of dispersion, and the like, rather than as special cases which may be adequately explained by an application of the older and more firmly established laws of solutions and of the purely chemical forces of primary and secondary valency. Sørensen<sup>2</sup> has said "the properties of colloidal solutions can be most efficiently inquired into by application, as far as possible, of the same views and methods as those generally applied to true solutions," and Loeb<sup>3</sup> affirms that "the variation of the physical properties of gelatin under the influence [for example] of hydrobromic acid is an unequivocal function of the number of gelatin bromide molecules formed, and colloidal speculations not based on the laws of classical chemistry are neither needed nor warranted." Pauli and Robertson have also, as the previous sections of this chapter reveal, favored a chemical conception of the reactions of the proteins, but their experiments were inconclusive in proving such a conception.

It will be recalled that the ion series above described were capable of revealing no chemical relationship whatsoever that could be interpreted in accordance with the hitherto known laws of valency. Thus divalent sulphate, monovalent acetate, and monovalent alcohol were found by Hofmeister to react in a similar way in inhibiting swelling or in producing coagulation; other monovalent radicals increased the swelling or inhibited coagulation. Pauli's series on the viscosity of blood albumin is

<sup>1</sup> J. LOEB, *J. Gen. Physiol.*, **1** (1918-19), 39; 237; 363; 483; 559; **2** (1919-20); 87; **3** (1920-21), 85; 247; *Science*, **52** (1920), 449.

<sup>2</sup> S. SØRENSEN, *Compt. rend. trav. lab. Carlsberg*, **12** (1917), 369.

<sup>3</sup> J. LOEB, *J. Gen. Physiol.*, **1** (1918-19), 378.

equally unexplainable as, in the series, the strong monobasic acid hydrochloric is followed by the weak monochloroacetic acid, the dibasic oxalic acid, the tribasic citric acid, and this in turn by the monobasic acetic acid, etc. So long as these series were accepted it was impossible to prove the existence of a definite stoichiometrical relationship in the interaction of inorganic ions with proteins.

Loeb has attacked the problem from a new angle. Previous investigators had studied the effect of inorganic ions by adding equivalent amounts of the ionogens to proteins prepared in a standard way, and had entirely failed to take cognizance of a most important variable in the system, namely, the hydrogen ion concentration. Loeb used protein solutions of uniform hydrogen ion concentration for his comparisons, and by so doing discovered an entirely different relationship, *i.e.*, that "acids, alkalies, and neutral salts combine with proteins by the same chemical forces of primary valence by which they combine with crystalloids, and that, moreover, the influence of the different ions upon the physical properties of proteins can be predicted from the general combining ratios of these ions." The principal investigations which have led to these conclusions will be presented in the following sections. The argument reveals evidence that goes far toward indicating the nonexistence or at least the inadequacy of the Hofmeister and Pauli series, and formulates the gelatin-salt equilibrium in terms of hydrogen ion concentration and valence.

**6. The Isoelectric Point of Gelatin.**—Ordinary gelatin is usually found to be nearly neutral, that is, it possesses a hydrogen ion concentration of about  $C_H = 10^{-7}$  or, in terms of Sørensen's logarithmic symbol,<sup>1</sup>  $\text{pH} = 7$ . This value will vary somewhat, but the highest grades of gelatin are usually of this order of hydrogen ion concentration. If, now, such a gelatin be pulverized and treated in solution with any neutral salt it will be found that the gelatin reacts with the cations but is unaffected by the anions. On the other hand, if the gelatin is first treated with an acid, and the excess of acid removed as completely as possible by washing with water, then it is observed that the gelatin will react with the anions, but will not be affected by the cations. If the original gelatin is first treated with a base, and the excess likewise removed, the gelatin will react only with the cations.

<sup>1</sup> See Appendix for a discussion of hydrogen ion concentration and pH.



Neutral gelatin possesses therefore the reacting properties of the alkali-treated substance, but these are quite opposite from the properties of the acid-treated material.

There must, obviously, be some point in the hydrogen ion concentration that is intermediate between the alkali and the acid conditions at which the combination of the gelatin with anions and cations would be equal or negative. Since neutral gelatin reacts as an alkali gelatin, this point must have a pH value less than 7.0. That is, the gelatin must be on the acid side of neutrality at this point of equal or zero reactivity with anions and cations.

Under the influence of an electric potential gelatin, in water and in alkaline solutions, is found to migrate toward the anode. That is, the neutral gelatin appears to give off hydrogen ions, and conducts itself as if it were an acid. In alkaline solutions, *e.g.*, in the presence of sodium hydroxide, it appears as if the gelatin had undergone a simple neutralization, hydrogen and hydroxyl ions having combined, and sodium gelatinate in an ionized state remaining. The gelatin ion, being the anion, migrates therefore to the anode. In acid solution, *e.g.*, in the presence of hydrochloric acid, the gelatin is found, however, to migrate to the cathode. That is, it conducts itself as if it had ionized, liberating hydroxyl ions which had combined with the hydrogen ions of the acid, and left in the solution the salt, gelatin chloride, also in an ionized state. The gelatin, being in this case the cation, migrates to the cathode. By starting with an alkaline or neutral gelatin and slowly adding acid, or by starting with an acid-protein and adding alkali, a point is eventually reached at which no migration of gelatin is observed. This is known as the *isoelectric point*. It was found by Michaelis,<sup>1</sup> and corroborated by other investigators, to be, for gelatin,  $C_H = 2 \times 10^{-5}$ , or in terms of Sørensen's symbol pH 4.7.

**7. Loeb's Method for the Study of the Gelatin-salt Equilibrium.**—It seemed probable that the point of equivalency in the reactivity of gelatin for anions and cations might be identical with the isoelectric point. This was demonstrated by Loeb<sup>2</sup> to be the case. One gram portions of gelatin, pulverized so as to pass a 60 mesh, but to be retained by an 80 mesh sieve, were treated with 100 c.c. portions of nitric acid or hydrochloric acid

<sup>1</sup> MICHAELIS, "Die Wasserstoffionenkonzentration," Berlin (1914).

<sup>2</sup> J. LOEB, *loc. cit.*

for an hour at 15°C. The concentrations of the acid used varied from N/8 to N/8192, and water served as a control. The several portions were then filtered and washed with 2 or 3 perfusions of cold distilled water to remove the excess of acid which remained in the film about the granules of gelatin. With series prepared in this manner a large number of tests were made. The swelling was measured directly by the height in millimeters to which the swollen particles rose in the cylindrical funnels used. The several portions were then placed in beakers, melted, made up to 100 c.c., *i.e.*, 1 per cent solutions, and the following determinations made:

The conductivity  $\left(\frac{10,000}{\text{ohms}}\right)$ , at 24°C.

The osmotic pressure expressed in millimeters height to which the 1 per cent gelatin solution rose in the manometer tube.<sup>1</sup>

The alcohol number, *i.e.*, the c.c. of 95 per cent alcohol required to produce a precipitate in 5 c.c. of the gelatin solution at 20°C.

The viscosity.

The hydrogen ion concentration determined by the colorimetric method<sup>2</sup> of Sørensen and Clark.<sup>3</sup>

**8. Gelatin Salts and Metal Gelatinates.**—The results obtained with hydrochloric acid are shown in Fig. 34.<sup>4</sup>

The most obvious point about these curves is the remarkable similarity revealed. The curve for viscosity is not included, but is stated to be parallel to that for the osmotic pressure. It is observed that all of the properties mentioned are high on the acid side of the isoelectric point, *i.e.*, in the region of gelatin chloride; that they reach a minimum at the isoelectric point; and that they again rise, but to a lesser extent, on the alkaline side of that point, *i.e.*, in the region of hydrogen gelatinate. The curve for conductivity is especially significant since it is a direct expression of the degree of electrolytic dissociation of the gelatin in the solution. At the isoelectric point the gelatin is unquestionably but very slightly dissociated, as the conductivity is there nearly zero. On the acid side the salt, gelatin chloride,

<sup>1</sup> *Vide* page 103, for the technique of the osmotic pressure determination.

<sup>2</sup> *Vide* Appendix, page 599, for a discussion of the colorimetric method for the determination of hydrogen ion concentration.

<sup>3</sup> *Cf.* W. M. CLARK, "The Determination of Hydrogen Ions," Baltimore (1920), 38.

<sup>4</sup> J. LOEB, *loc. cit.*, 1 (1918), 44.

is apparently highly dissociated, as indicated by the high conductivity. On the opposite side of the isoelectric point, the weak acid, hydrogen gelatinate, is, as would be expected, dissociated,

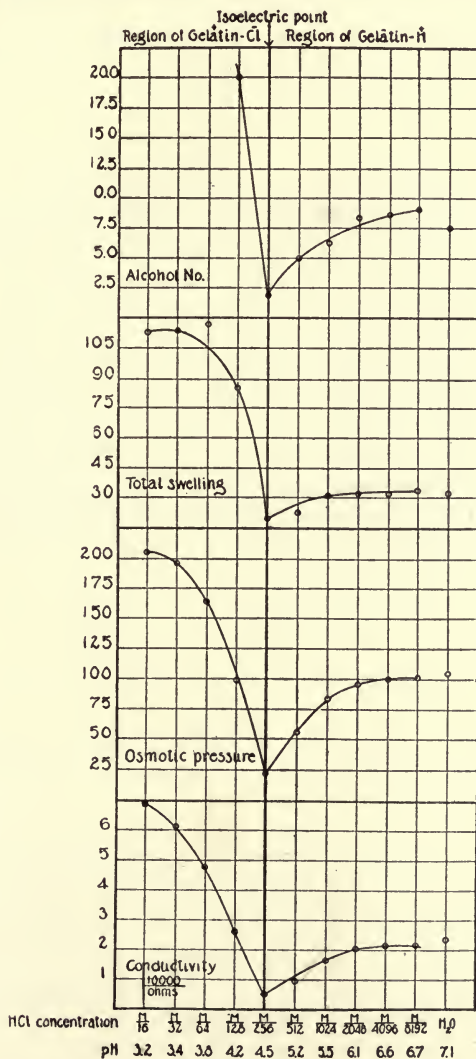

FIG. 34.—Curves of the conductivity, osmotic pressure, swelling, and alcohol number of gelatin previously treated with various concentrations of HCl and then freed from excess of HCl by washing with water.

but to a lesser degree, as weak acids do not dissociate to the same degree as salts.

Fischer<sup>1</sup> explains these observations as follows: The gelatin and acid combine to form a gelatinate. This has a greater solubility for water—hence the increase in swelling and increase in viscosity; also greater solubility in water—hence the increase in osmotic pressure. The dissociation value is also higher than the degree of hydrolysis—hence the greater conductivity and the greater concentration of free H or OH ions.

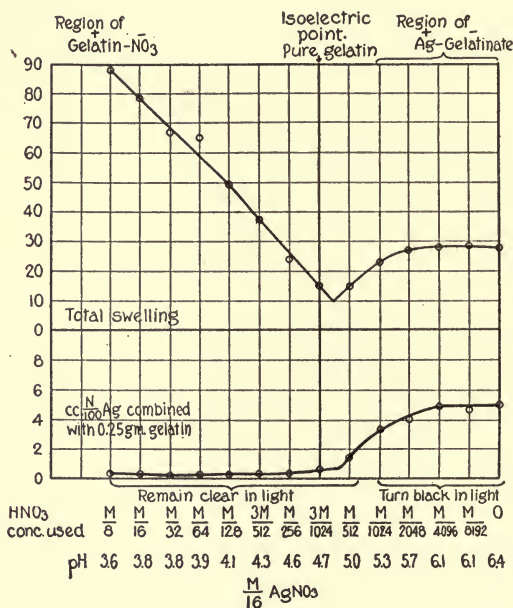

FIG. 35.—Gelatin treated with different concentrations of  $\text{HNO}_3$ , from M/8 to M/8192, washed, and then treated with the same concentration of  $\text{AgNO}_3$ , (M/16), and then washed again.

The parallelism between the several curves is so perfect that Loeb was led to conclude that the degree of conductivity, *i.e.*, the ionization of the gelatin, determines to a large extent many of the other properties of the gelatin solution. The colloid behavior, however, of soaps in alcohol, benzene, etc., or of rubber in carbon disulphide or toluol or gasoline does not appear to be explainable by any theory involving ionization.

Upon modifying the experiment by the addition of sodium sulphate, in equal concentration to all samples, sodium gelatinate would be formed on the alkaline side of the isoelectric point.

<sup>1</sup> MARTIN FISCHER, personal communication.



This, being a salt, would be expected to produce a high ionization, hence a high conductivity, and all other properties would likewise be expected to be higher than in the lesser ionized hydrogen gelatinate (free gelatin). This is in fact found to be the case.

When silver nitrate is used in place of sodium sulphate, by adding equal amounts to each of the acid-treated gelatins, the acid used being in this case nitric acid, we would now predict that those gelatins which have a pH value less than 4.7 would react with the anion only. That is, gelatin nitrate would

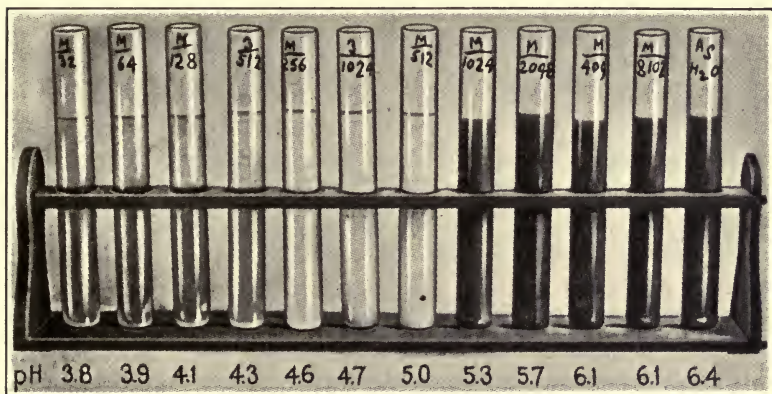

FIG. 36.—Photograph of the gelatin solutions whose curves are contained in Fig. 35, taken a week after the experiment was made. (By permission of Jacques Loeb.)

be produced at  $\text{pH} < 4.7$ . In those proteins where  $\text{pH}$  is greater than 4.7 we would expect only the cation to react, with the formation of silver gelatinate. When  $\text{pH} = 4.7$  no reaction with either ion would take place. That this is the case has been previously stated. The experiment was performed in the dark, but within a few minutes after exposure to the light the samples that had a  $\text{pH}$  greater than 4.7 (in this instance 5.0) had turned dark brown, due to the reducing action of the light upon the silver salt, while on the more acid side the liquids remained clear. At the isoelectric point precipitation due to insolubility of the gelatin had taken place, but no silver was present. The accompanying curves and photograph<sup>1</sup> make clear this striking experiment.

Many other salts containing a readily detectable cation were tested with identical results. Thus when the gelatins which

<sup>1</sup> J. LOEB, *loc. cit.*, 1 (1918), 240.

have been made to varying pH by treatment with hydrochloric acid are further treated with nickel chloride, and the excess of salt washed out with cold water, the presence of nickel may easily be determined in all solutions with a  $\text{pH} > 4.7$ , and shown to be absent at  $\text{pH} \bar{\leq} 4.7$ . Dimethylglyoxime produces a crimson color in the presence of nickel, and may be used with striking results for this test. Copper salts, when added in the above manner, produce a blue solution with the gelatin portions of a pH greater than 4.7, but show no trace of existence in the solutions of a pH less than 4.7.

Similar experiments may be made which serve equally well to demonstrate the combination of gelatin with the anion of salts at a pH value of less than 4.7. For this purpose the gelatin is treated, after the acid treatment to obtain varying hydrogen ion concentrations, with salts in which the anion may be easily shown to be present or absent. Potassium ferrocyanide answers the purpose very well. After the salt has been allowed to react for an hour, the gelatins are filtered, washed as before specified to remove all excess of salt, and made up to 1 per cent solutions. In the course of a few days, in those samples of  $\text{pH} < 4.7$  the gelatin solutions turn blue, due to the formation of the ferriferro salt, while all others remain colorless. This shows that only when the gelatin has a  $\text{pH} < 4.7$  does it interact with anions of added salts. Other salts, as potassium sulphocyanide, which turns red upon the addition of a ferric salt, may be employed with equal success to demonstrate this type of combination.

It seems conclusively demonstrated, therefore, that gelatin is an ampholyte which may ionize either as an acid or as a base, that is, it may give off an excess of hydroxyl ions, or an excess of hydrogen ions, depending upon the hydrogen ion concentration of its solution. Its reactions with acids, bases, and salts are then entirely parallel with those of the inorganic ampholytes. As isoelectric gelatin it is insoluble and unionized. With acids it reacts forming a gelatin salt, and its combination with other salts is then confined to the anions of the latter. With bases it reacts to form metal gelatinate, and on interacting with other salts can then combine only with the cations.

At any given condition of equilibrium the amount of gelatin chloride or of potassium gelatinate formed will according to the Mass Law be proportional to the concentrations of hydrochloric acid and of potassium hydroxide respectively that are present.

This also is shown to obtain by the curves in Fig. 34, and by numerous other experiments. This point was further demonstrated by the addition of hydrochloric acid in small amounts to isoelectric gelatin and the simultaneous determination of the hydrogen ion concentration. It was shown that the same amount of chlorine was always in combination with a given mass of gelatin for the same pH. This means that if the concentration and pH of a gelatine are known, the amount of chlorine in combination with it may readily be calculated. This holds equally well for bases, for at the same pH the amount of cation in combination is always the same.

### 9. The Influence of Valency upon Protein-salt Formation.—

The most potent argument in favor of a purely chemical conception of protein-salt formation may be found in the relative behavior of inorganic anions and cations of different valency. In the weak dibasic and tribasic acids such as oxalic, citric, phosphoric, etc., it has been shown<sup>1</sup> that the primary ionization occurs much more readily than the secondary, and this in turn more readily than the tertiary. In oxalic acid, for example, the primary ionization:

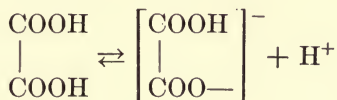

is about seven hundred and sixty times the secondary ionization.

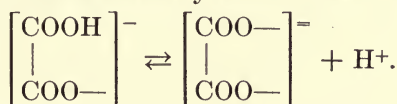

The primary ionization of phosphoric acid:

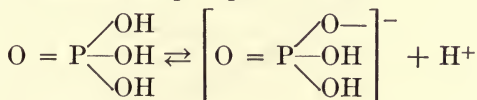

is about fifty thousand times the secondary ionization:

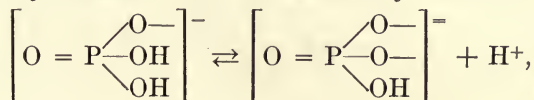

and this in turn about five hundred thousand times the tertiary ionization:

<sup>1</sup> See Appendix, page 579, for ionization of acids and bases.

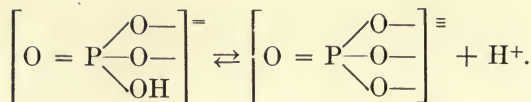

In the stronger sulphuric acid however the primary ionization:

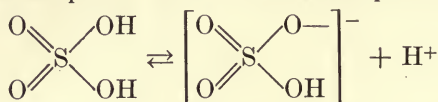

is only about thirty three times the secondary ionization:

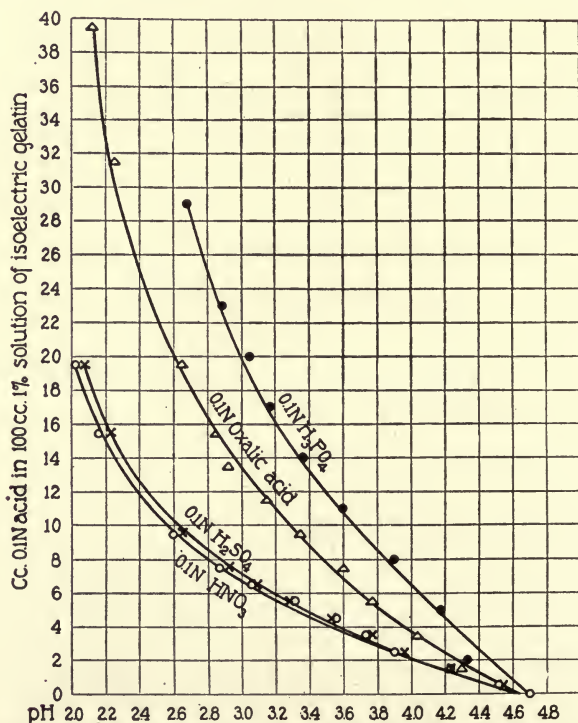
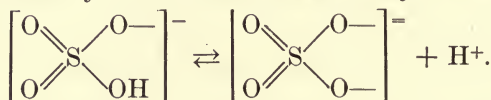

FIG. 37.—Curves for the number of cc. of 0.1N HNO<sub>3</sub>, H<sub>2</sub>SO<sub>4</sub>, oxalic, and phosphoric acids required to bring 1 gm. of isoelectric gelatin to different pH (in 100 cc. of solution).

It would therefore be expected that in interaction with the proteins the former weak acids would behave as if they were monobasic, one hydrogen only being effective, while in the strong



sulphuric acid both hydrogen ions would be effective and the acid would react as dibasic. This was found to be the case by the following experiment. Tenth normal solutions of several acids of varying basicity were added in varying amounts to gelatin that had been rendered isoelectric, and the pH of 1 per cent solutions determined for each addition. Upon plotting the pH value against the c.c. of the N/10 acid added it was observed that the curves were identical for all of the monobasic acids and the strong dibasic sulphuric acid, but that the curve for oxalic

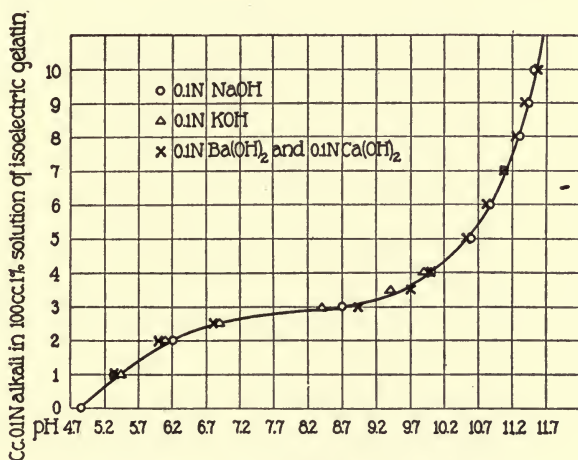

FIG. 38.—Curves for the number of cc. of 0.1N NaOH, KOH, Ba(OH)<sub>2</sub>, and Ca(OH)<sub>2</sub> required to bring 1 gm. of isoelectric gelatin to different pH (in 100 cc. of solution). All four curves are identical.

acid showed that about twice, and for phosphoric acid about three times, the volume were required to produce a given pH as for the monobasic acids. This is shown in Figure 37.<sup>1</sup> If, however, the oxalic and phosphoric acids are treated as if they were monobasic, and added therefore in *equivalent molecular* proportions, the curves for all were identical.

On applying this principle to bases we should expect the strong diacid bases calcium and barium hydroxides to act as diacid rather than as monacid bases. On adding tenth normal solutions of these, and of sodium and potassium hydroxides, to isoelectric gelatin, it was found that the curves plotted as before were identical, as shown in Figure 38.<sup>1</sup>

<sup>1</sup> J. LOEB, *loc. cit.*, 3 (1920), 100; 104.

The following table shows the c.c. of 0.01N acid in combination with 10 c.c. of a 1 per cent gelatin solution at different pH:<sup>1</sup>

TABLE 41.—COMBINATION OF GELATIN WITH ACIDS

pH	3.1	3.2	3.3	3.4	3.5	3.7	3.9	4.1	4.2	4.3
Nitric acid.....	4.35	4.1	3.6	3.2	2.85	2.45	1.9	1.45	....	0.75
Oxalic acid.....	9.6	8.75	7.6	6.7	6.00	4.3	3.0	....	1.65	...
Phosphoric acid.....	....	12.4	10.4	9.8	9.00	7.4	5.8	4.5	2.6	2.1

Loeb therefore reaches the conclusion that "the ratios in which the ions combine with proteins are identical with the ratios in

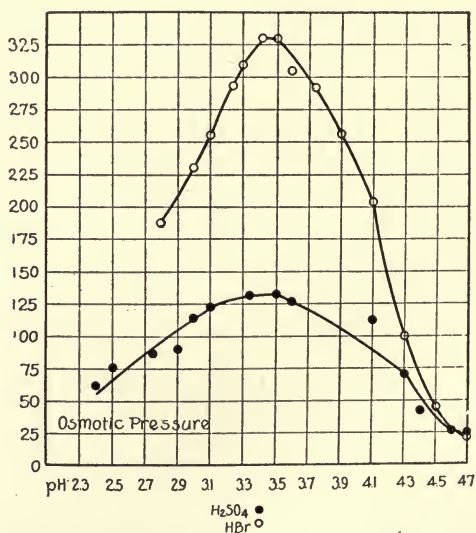

FIG. 39.—Osmotic pressure curves for gelatin sulfate and gelatin bromide. Abscissae represent pH; ordinates, osmotic pressure; showing that for the same pH the osmotic pressure is higher when HBr than when H<sub>2</sub>SO<sub>4</sub> is added to gelatin.

which the same ions combine with crystalloids. Or, in other words, the forces by which gelatin and egg albumin (and probably proteins in general) combine with acids or alkalis are the purely chemical forces of primary valence."

If this is the case, as seems most highly probable, then since, as has been shown, the viscosity, osmotic pressure, swelling, and alcohol number all reveal curves that are parallel to the curve

<sup>1</sup> J. LOEB, *Science*, **52** (1920), 454.

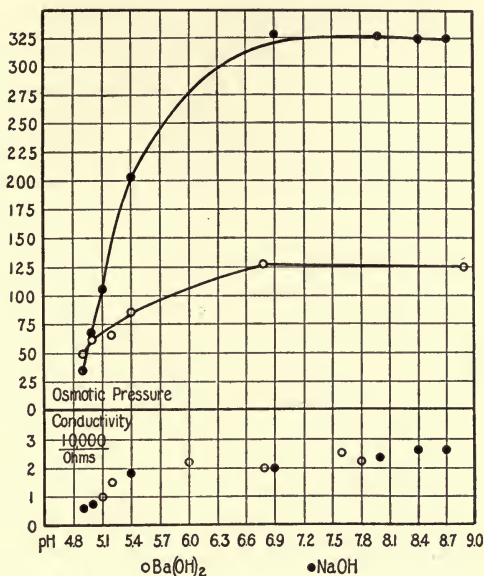

FIG. 40.—Showing that while the curves for conductivity of sodium and barium gelatin are practically identical, the curves for the osmotic pressures are very different.

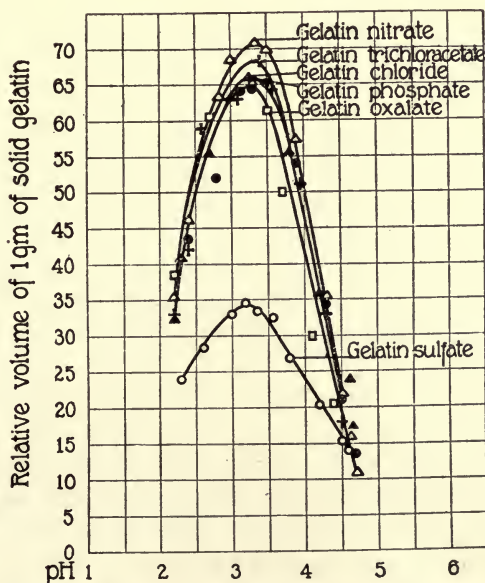

FIG. 41.—Influence of HCl, HNO<sub>3</sub>, H<sub>3</sub>PO<sub>4</sub>, H<sub>2</sub>SO<sub>4</sub>, trichloroacetic, and oxalic acids on the swelling of gelatin.

for conductivity, the properties enumerated must be dependent upon and a function of the ionization of the protein which, in turn, has been shown to be defined by the hydrogen ion concentration. And it has furthermore been shown that all those acids whose anions combine as monovalent ions, and those bases whose cations combine as monovalent ions, raise these several prop-

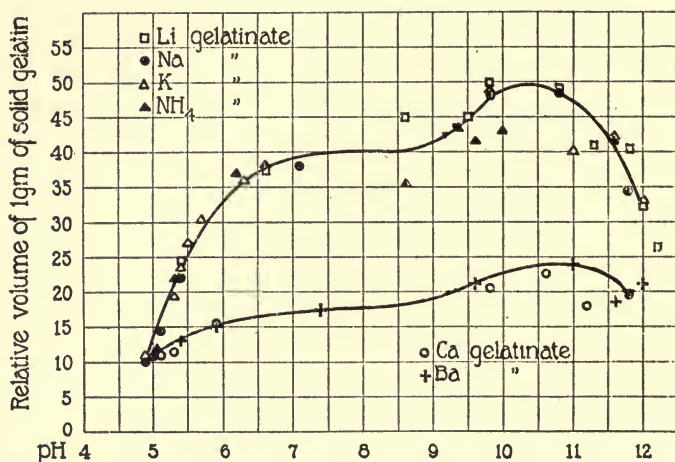

FIG. 42.—Curves for the effect of different bases on swelling. Those for LiOH, NaOH, KOH, and NH<sub>4</sub>OH are practically identical and about twice as high as those for Ca(OH)<sub>2</sub> and Ba(OH)<sub>2</sub>.

erties of the proteins much more than those acids and bases whose anions and cations respectively combine as bivalent ions for the same pH. Numerous experiments have confirmed this general rule. Figures 39 and 40 show the relative effects of monovalent and divalent acids and bases respectively upon the osmotic pressure of gelatin solutions at different pH values.<sup>1</sup>

Figures 41 and 42 show the effects of such acids and bases upon the swelling of gelatin.<sup>2</sup>

Figures 43 and 44 show similar effects upon the viscosity of gelatin solutions.<sup>3</sup>

In connection with the ionization theories of the proteins, the theory advanced by Procter and Wilson to account for the swelling of gelatin, and the mathematical confirmation of that theory

<sup>1</sup> J. LOEB, *loc. cit.*, **1** (1918-19), 567; 493.

<sup>2</sup> J. LOEB, *ibid.*, **3** (1920), 253; 256.

<sup>3</sup> J. LOEB, *loc. cit.*, **3** (1920), 101; 104.



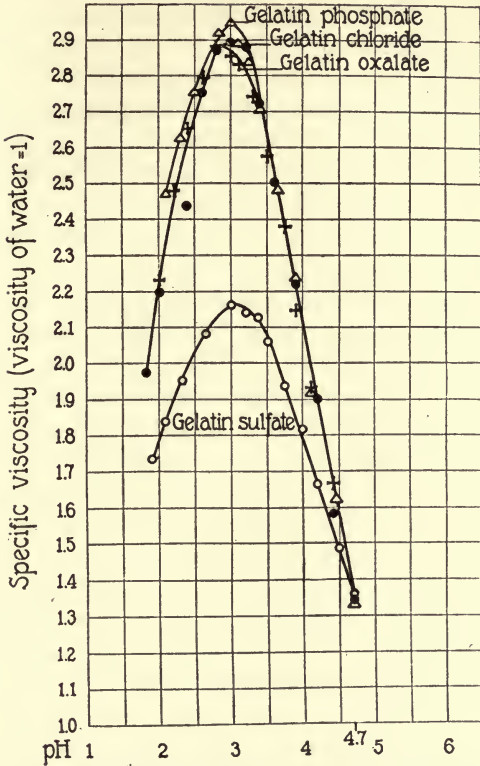

FIG. 43.—The curves of specific viscosity of 1 per cent solution of originally isoelectric gelatin brought to different pH by different acids.

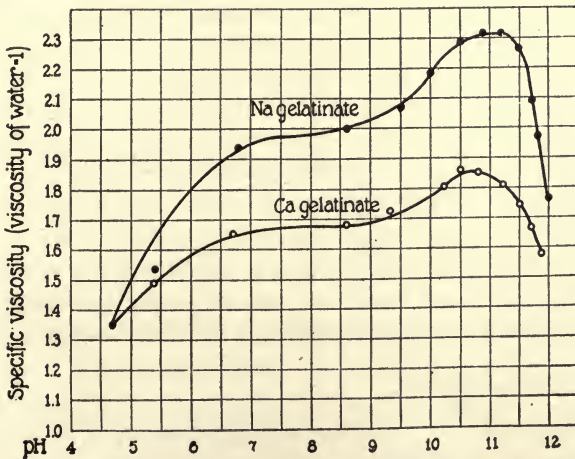

FIG. 44.—Curves for specific viscosity of Na and Ca gelatinates for different pH.

by Wilson should be recalled.<sup>1</sup> They assumed and demonstrated a chemical combination between the gelatin and one of the ions of the electrolyte in which it was immersed, and accounted stoichiometrically for the swelling phenomena observed by a mathematical treatment of the ion relations involved. Wilson regards this as the strongest kind of evidence that with gelatin and acids we are dealing with ionic reactions, and in acid solution the positive electrical charge on gelatin is due to the ionization of a gelatin salt of that acid.

**10. The Depressing Action of Salts.**—It has been observed by a number of investigators that the action of neutral salts upon the physical properties of proteins differs from that of acids and bases. Pauli<sup>2</sup> regards the combinations of neutral salts with electrically neutral protein as adsorption compounds, while reaction with acids and bases he regards as true salt formation. Lillie<sup>3</sup> has stated that, while acids and bases increase, salts depress the osmotic pressure of gelatin. Loeb<sup>4</sup> has reported that neither of these statements is correct on account of the failure of the writers to take into account the hydrogen ion concentration of the solutions. He asserts that "when acids or alkalies are added to isoelectric gelatin both ions of the acid or alkali influence the physical properties of proteins, but in an opposite direction. When we add acid to isoelectric protein the hydrogen ions increase but the anions depress the osmotic pressure and viscosity of the protein solution (and this depressing action increases with the valency of the anion of the acid). As long as little acid is added to isoelectric protein the augmenting action of the hydrogen ion on these properties increases more rapidly with increasing concentration of the acid than the depressing action of the anion; while when the pH of the solution falls below 3.3 or 3.0 the reverse is the case. This causes the drop in the curves for osmotic pressure, viscosity, and swelling below a pH of 3.0.

"When we add alkali to isoelectric protein the OH ions (or the diminution of the concentration of hydrogen ions) effect an increase in the osmotic pressure, viscosity, etc., of the solution of metal proteinate while the cation of the alkali depresses these properties with a force increasing with the valency of the cation.

<sup>1</sup> *Vide* pages 176 to 182.

<sup>2</sup> W. PAULI, *Fortschr. naturwiss. Forschung*, **4** (1912), 223.

<sup>3</sup> R. S. LILLIE, *Am. J. Physiol.*, **20** (1907-08), 127.

<sup>4</sup> J. LOEB, *J. Gen. Physiol.*, **3** (1921), 391.

In the lowest concentrations of the alkali added the augmenting action of the OH ion on the physical properties of the metal proteinate increases more rapidly with the concentration than the depressing effects of the cation of the alkali; while in higher concentrations, *i.e.*, as soon as the pH becomes about 10.0 or 11.0, the reverse is the case.

“When, however, neutral salts are added to protein solutions we no longer notice an opposite effect of the oppositely charged ions. When neutral salts are added to isoelectric gelatin no effect is noticed as long as the concentration of salt does not reach the value required for precipitation. When neutral salt is added to a protein solution on either side of its isoelectric point only a depressing action of that ion which has the opposite sign of charge as the protein ion is observed. No augmenting action of the ion with the same sign of charge as the protein is noticeable.”

In other words, Loeb has pointed out an undisputed fact, and has given it a new explanation. He notes that the addition of any neutral salt to a pure gelatin of any pH (provided the addition of such salt does not involve an alteration in the pH of the solution) results in a depression of the osmotic pressure, viscosity, etc., of the solution. He regards the hydrogen and the hydroxyl ions as unique in that they alone are possessed of the power to increase these properties, while all other ions depress them. This peculiarity is attributable to the power of these ions to produce ionized gelatin, either as the gelatin-acid salt, or as the metal gelatinate. When acid is added to isoelectric gelatin, gelatin-acid salt is produced and for this reason the osmotic pressure, viscosity, etc., increase rapidly. The anion of the acid is constantly exerting its depressing influence upon these properties, but the extent of such effect is not as great as the increasing effect due to the ionization, hence these properties increase. “Near the isoelectric point the amount of gelatin-acid salt formed increases very rapidly with the addition of acid, but when the pH approaches 3.0 the addition of the same amount of acid which near the isoelectric point caused a considerable change (increase in ionization) now causes only a slight change, while when the pH falls below 3.0 the depressing influence of the anion continues with increasing concentration of the electrolyte.”

Thus if we start with gelatin at a pH of 4.0 and add increasing amounts of hydrochloric acid, the viscosity will rise at first due

to an increasing ionization caused by the hydrogen ion. The depressing effect of the chloride ion, which has been acting all the time, becomes manifest when pH becomes smaller than 3.0, at which time the viscosity begins to fall. If sodium chloride were used in place of the acid, the sodium ion, since it cannot produce an increase in the ionization of the gelatin, is entirely without effect, while the chloride ion, being depressing, results in a decrease in viscosity from the start. This is shown in Fig. 45. If calcium chloride and lanthanum chloride are used in place

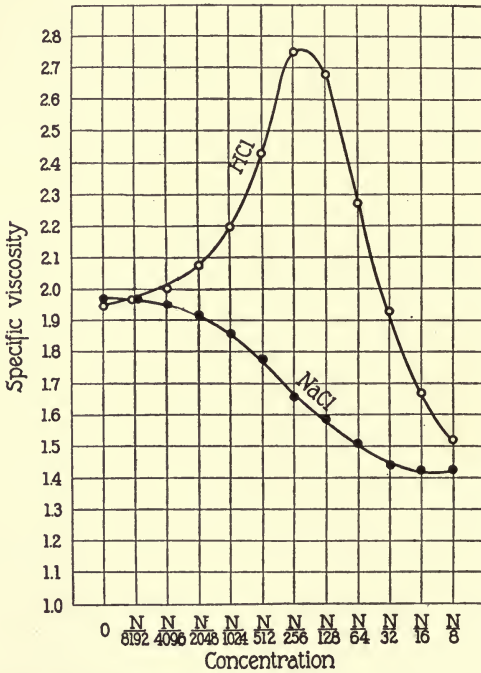

FIG. 45.—Difference in the effect of different concentrations of NaCl and of HCl on the specific viscosity of a 1 per cent solution of gelatin chloride of pH 4.0. In the case of NaCl we observe only the depressing effect of the Cl ion; in the case of HCl we notice an augmenting effect of the H ion and a depressing effect of the Cl ion, the latter prevailing as soon as the concentration of acid added is  $>N/256$ .

of sodium chloride, and in molecularly equivalent quantities, the depressive effect of the chloride will be in the order  $\text{LaCl}_3 > \text{CaCl}_2 > \text{NaCl}$ , *i.e.*, in the order of the amounts of Cl present, but if used in equi-normal quantities, *i.e.*, amounts containing the same quantity of Cl, the effects are identical. If sodium



sulphate and sodium ferrocyanide are used in amounts which are also equivalent in respect to their anions (equimolar), it is found that the order of depression is  $\text{Na}_4\text{Fe}(\text{CN})_6 > \text{Na}_2\text{SO}_4 > \text{NaCl}$ . That is, the depression is in the order of the valence of the anion.

The above salt effect is based upon the maintaining of a constant pH. If a salt is added which results in a change in the

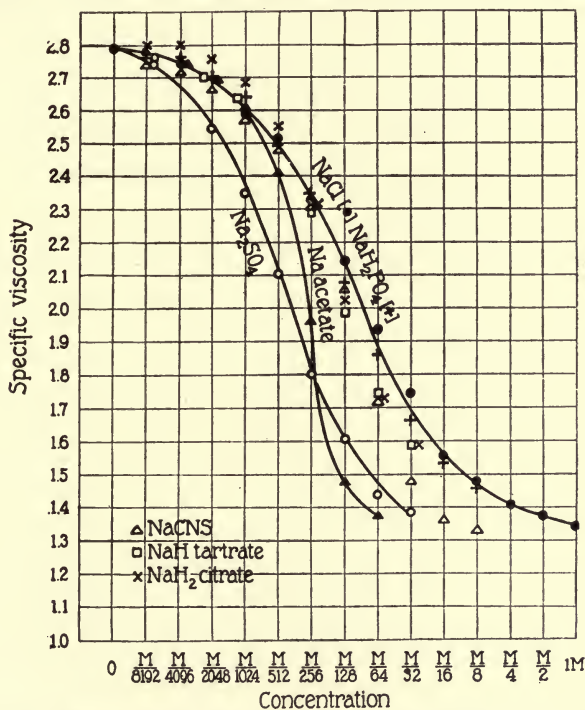

FIG. 46.—The depressing effect of different salts with monovalent anion ( $\text{NaCl}$ ,  $\text{NaH}_2\text{PO}_4$ ,  $\text{NaClNS}$ ,  $\text{NaH tartrate}$ , and  $\text{NaH}_2$  citrate) on the specific viscosity of 1 per cent solution of gelatin chloride of pH 3.0. The effect of  $\text{NaCl}$  and  $\text{NaH}_2\text{PO}_4$  are identical since the pH is not altered by the addition of these salts. The depression in the values for the specific viscosity is greater in the case of  $\text{Na acetate}$  than in the case of  $\text{NaCl}$  for the reason that the  $\text{Na acetate}$  raises the pH of the gelatin solution.

pH, then the ionization factor would have also to be considered. Thus the addition of sodium acetate to gelatin chloride would, through the hydrolytic dissociation of the salt, make the solution slightly more alkaline, and have an effect similar to the addition of a small amount of an alkali. This would obviously bring the gelatin chloride nearer to the isoelectric point, or, in other words,

repress the ionization. Thus the depression in viscosity due to the acetate ion would be augmented by the decrease in ionization, and a sharper fall with increasing concentration would result. This is shown to be the case from Fig. 46.

If, on the other hand, a salt which hydrolyzed with the liberation of hydrogen ions as, for example, aluminium chloride, stannic chloride, etc., were to be added to a gelatin chloride of a pH of 4.0, it would be expected that the depressing effect of the chloride ions would be opposed by the effect of an increased ionization, and an actual increase in viscosity would probably be observed. Copper chloride would produce a lesser degree of ionization, and whether the mean of the opposing effects would produce an actual rise or decrease in viscosity would depend on the exact ratio of the two influences.

We have discussed thus far only the reactions and relations on the acid side of the isoelectric point. But what has been said above applies *mutatis mutandis* on the alkaline side. Sodium hydroxide, for example, increases the ionization of gelatin as sodium gelatinate. This increase in ionization results in an increase in viscosity, etc. The sodium ion is acting as a depressing agent, but not until the pH reaches about 10.0 does it exceed the opposite influence of the hydroxyl ions. Sodium chloride produces a depressing action throughout, due to the sodium ion, since no effect is produced upon ionization. Any other salt solutions containing equivalent amounts of any monovalent cation act similarly. Divalent and trivalent cations exert increased effects, while anions are without influence. Salts like sodium acetate or sodium silicate, since on the alkaline side of the isoelectric point they increase the ionization, would be expected to oppose the depressing effect of the sodium ion, and an actual increase in viscosity, etc., might be observed. The author<sup>1</sup> has found this to be the case with sodium silicates, and, which is of great importance in the present theory, the degree of increase produced by seven silicates of varying composition was found to be proportional to the degree of hydrolytic dissociation which these silicates underwent in dilute solution. Curves showing a maximum of viscosity and swelling at a pH of about 9.0 are thus obtained. These are shown in Fig. 47.

**11. The Micelle Theory of McBain.**—The data that have been given upon the conductivity and osmotic pressure of gelatin

<sup>1</sup> R. H. BOGUE, *J. Ind. Eng. Chem.*, **14** (1922), 32.

when dissolved in dilute acids or bases, and the theories advanced to account for such action, find excellent confirmation and support in the micelle theory postulated by McBain and his pupils<sup>1</sup>

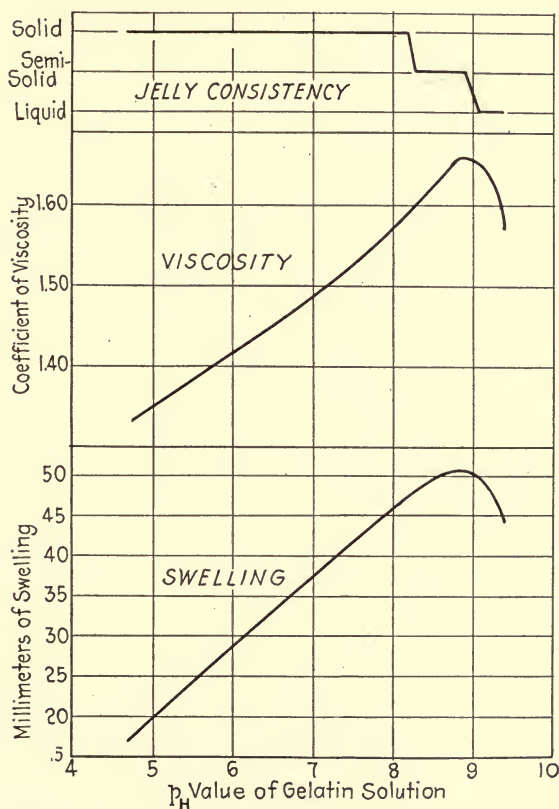

FIG. 47.—The jelly consistency, viscosity, and swelling of gelatin at varying pH values.

to account particularly for the behavior observed with soap solutions. The importance of their findings has, however, far outdistanced the original investigations, and the conclusions which were derived from an intensive study of sodium palmitate appear to be equally applicable to the large group of colloidal electrolytes of which the proteins are important members.

<sup>1</sup> J. W. McBAIN and TAYLOR, *Ber.*, **43** (1910), 321; *Z. physik. Chem.*, **76** (1912), 179; J. W. McBAIN and C. S. SALMON, *J. Am. Chem. Soc.*, **42** (1920), 426.

McBain<sup>1</sup> defines *colloidal electrolytes* as "salts in which one of the ions has been replaced by a heavily charged, heavily hydrated ionic *micelle* which exhibits equivalent conductivity that is not only comparable with that of a true ion but may even amount to several times that of the simple ions from which it has been derived. In other words, this ionic micelle is a typical but very highly charged colloidal particle of very great conductivity." Of particular significance is the relation defined between conductivity and osmotic pressure. "The conductivity of such a colloidal electrolyte is quite comparable with that of an ordinary electrolyte. On the other hand, since the ionic micelle exhibits only the osmotic effect characteristic of an ordinary colloid, the total osmotic activity of the colloidal electrolyte is correspondingly deficient and may be distinctly less than that of a non-electrolyte. Thus high conductivity goes hand in hand with only moderate osmotic effects."

The principal evidence for the existence of the ionic micelle is based upon a comparison of conductivity and osmotic data. For example, in concentrated solutions of the higher soaps the osmotic activity is often only about half that required to explain the conductivity. Whereas the conductivity is nearly as great as that of an inorganic salt, the osmotic pressure, on the other hand, is only about half that of a non-electrolyte such as sucrose. The osmotic activity appears therefore to correspond with that of the inorganic ion only, while "the other half of the current must be carried by an ion that is colloidal so as not to exhibit appreciable osmotic activity, and that nevertheless retains the sum total of the electrical charges of the ions from which it was derived. This is the ionic micelle." Taking potassium laurate as an example, when the entire osmotic pressure is attributed to the potassium ion, about half of the conductivity must be ascribed to the colloid. But this portion of the conductivity ascribed to the ionic micelle of potassium laurate is about three times greater than could be exhibited by the separate laurate ions had they retained an independent existence. This McBain accounts for by pointing out that, as predicted from Stoke's Law, the resistance offered to a particle increases directly with its diameter, and that when a number of small particles coalesce, the diameter of the large particle does not increase in the same

<sup>1</sup> J. W. McBAIN, "Third Report on Colloid Chemistry," British Assoc. for the Adv. of Science (1920), 2.



ratio as the electric charge, the latter being equal to the sum of the charges added.

The formula ascribed to the ionic micelle of sodium palmitate is written:

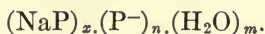

The exponents  $x$ ,  $n$ , and  $m$ , which indicate the ratio of the components of the micelle, may vary continuously with change in concentration or temperature or upon the addition of salts.

It does not appear to be a difficult matter to apply the micelle theory to the reactions of gelatin and to reconcile its existence with the experimental findings of Loeb, Procter, Wilson, Robertson, and others. Consider the salt sodium gelatinate. The formula of the ionic micelle would be:

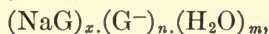

in which  $(\text{NaG})_x$  represents a variable amount of undissociated molecules of sodium gelatinate, and  $(\text{G}^-)_n$  a variable number of negatively charged gelatin ions. These are combined with a variable amount of water of hydration. The sodium gelatinate may be represented by:

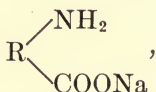

and the negatively charged gelatin ions by:

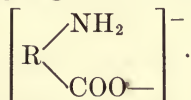

There would also be present in the system, according to Loeb, a variable amount of isoelectric gelatin and of sodium hydroxide. The former might or might not become a part of the ionic micelle, but its presence could not materially modify the nature of that body. The sodium hydroxide would constitute the determining influence in the equilibrium which should define the relative values of  $x$ ,  $n$  and  $m$ . By the application of the Mass Law, any increase in the concentration of the sodium ion, whether by the addition of sodium hydroxide, or a sodium salt, would decrease the concentration of the gelatin ion and increase the concentration of the unionized sodium gelatinate. This would seem at

first glance to contradict Loeb's<sup>1</sup> findings that the conductivity of the gelatin salt increases regularly with acid or base additions, for the conductivity must be ascribed to the ionized portion of the gelatin, and as acid or base are added, this ionized portion should decrease. A more detailed inspection of the reaction will show, however, that the objection is not well made. In the first place, in the salt sodium gelatinate,

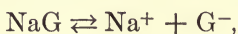

and

$$\frac{[\text{Na}^+] \times [\text{G}^-]}{[\text{NaG}]} = K.$$

As  $[\text{Na}^+]$  is increased,  $[\text{G}^-]$  must decrease, but the product  $[\text{Na}^+] \times [\text{G}^-]$  must remain constant, and the electric current will be carried equally well by a high sodium and low gelatin ion concentration as by equivalent amounts of the two. Furthermore, it must not be lost sight of that isoelectric gelatin is present in equilibrium with the other components represented, and the sodium hydroxide establishes not only the equilibrium between ionized and unionized sodium gelatinate, but also between isoelectric gelatin and sodium gelatinate. So, concomitantly with a decrease in ionization of the already existing sodium gelatinate, there is also taking place a continuous increase in the total amount of sodium gelatinate (ionized and unionized) in the system.

If we consider now the salt, gelatin chloride, the conclusions will be nearly the same. The formula of the ionic micelle would be:

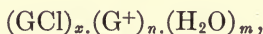

where the equilibrium between the ionized and unionized gelatin chloride could be represented by:

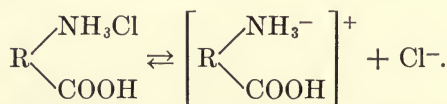

The effect of further additions of acid would be similar to those found to obtain with further additions of base to the sodium gelatinate.

<sup>1</sup> J. LOEB, *J. Gen. Physiol.*, **3** (1920), 260.

PART II  
TECHNOLOGICAL ASPECTS

THE SECOND GREAT MISSION OF SCIENCE IS TO APPLY ALIKE TO  
THE SERVICE OF MAN THE KNOWLEDGE OF THE AGES AND THE  
LIGHT OF THE YOUNGEST DAY, THAT LIFE MAY BE RICHER IN  
OPPORTUNITY





# PART II

## TECHNOLOGICAL ASPECTS

### CHAPTER VI

#### THE MANUFACTURE OF GLUE AND GELATIN

BY RALPH C. SHUEY<sup>1</sup> M.S.

Glue is cooked from the hides of bulls.  
(Pliny, about 50 A.D.)

	PAGE
I. Raw Materials.....	271
II. Manufacture.....	277
1. Hide Glue.....	277
Preparation and Preservation of Stock.....	277
Soaking and Washing.....	278
Liming.....	279
Washing and Deliming.....	281
The Boiling Process.....	282
Clarification and Filtration.....	287
Evaporation.....	290
Chilling and Spreading.....	292
Drying.....	294
2. Bone Glue.....	300
3. Ossein.....	303
4. Gelatin.....	306
III. By-Products.....	307
IV. A Select Bibliography on the Manufacture of Glue and Gelatin...	313

The glue making process, in its simplest terms, consists of nothing more than the production of a concentrated soup stock or consommé from certain animal refuse, and its subsequent purification and drying for the market.

#### I. RAW MATERIALS

The raw materials used in the making of glue and gelatin are, in the general order of their glue making value: skin or hide, connective tissue, cartilage, and bone. Muscle tissue is of no value. Horns and hoofs contain no gelatin. However, the

<sup>1</sup> Chemical Engineer with the Redmanol Chemical Products Company of Chicago. Formerly with the Armour Glue Works of Chicago.

horn piths, the inner bony core of the horns, are an important source of ossein.

Hide is, of course, so valuable to the tanner that only those parts which he cannot use find their way to the glue maker. Calf skin, although higher in mucin-like substances, yields the best and clearest gelatin. Kip stock, or the skin from almost mature calves, comes next, and finally the hide from the mature cattle. Skins of other animals are handled similarly to those of cattle, and for the sake of brevity those of cattle alone will be treated in this chapter. Notable among other sources are: sheep, goat, deer, coney, pig, dog, horse and in fact the scraps from the hides and pelts of all animals which find their way into any manufacturing process. The term hide is applied to the skins of the larger animals while that of the smaller animals may carry the term skin or simply stock. Coney stock is the partially dehaired and shredded skins of rabbits, a by-production from the hat maker.

The scrap from the tanner is often sorted into classes which allow the glue maker to get much more uniform treatment than if everything were handled together. Hide pieces are the portions trimmed off in preparing the hide for the tanner. The pates or faces are prized by the glue maker, but the mucous membranes of the mouth and nose swell rapidly, and being easily overheated are apt to show abnormal losses. Ears are harder, have considerable adhering flesh and because of the varying thickness do not lime uniformly. The hair of the interior of the ear is removed and used in making "camel's hair" brushes. Tails if stripped of the bone give a satisfactory product.

After the tanner has unhaired and limed his hides he passes them through the fleshing machine, a machine having spiral blades mounted on a roller for the purpose of removing all adhering flesh and fat left by the butcher. These trimmings, known as fleshings, as well as splits, or still deeper trimmings taken off by splitting knives, give glues similar to hides but of somewhat lower grade.

Skivings are shavings taken off later in the tanning process by a machine somewhat similar to a planer for the purpose of giving the leather a uniform thickness and appearance. As the tanning process seems to be as much physical as chemical it ought to be possible to remove the tanning material and use the recovered product for glue. Many patents have been taken out for such

processes, but very few of them are being worked at present. Alum tanned and chrome tanned leathers are more easily handled than those produced with tannin. In general the processes consist of strong alkali treatment with either caustic or carbonate of soda, followed by acid treatment and finally bleaching with hydrogen peroxide or a strong oxidizing agent.

Raw hide scraps, lace leather, worn out raw hide pinions and "loom pickers" can be handled the same as other scrap.

Sinews or tendons trimmed off by the butcher require slower treatment than hide stock but yield a very good grade of glue.

Cartilaginous material may be handled with either sinews or bone: this is generally determined by the material with which it is associated.

Bones from different parts of the body vary somewhat in composition. The soft bones of the head and shoulders yield more glue than the thigh bones and thick parts of the vertebræ. In general the tubular bones are poorer in glue than the flat bones. Young animals have less mineral matter in the bones than do older animals, but they also have relatively more water. In the teeth, the dentine and cement are true bony structure while the enamel is very high in lime and magnesia, relatively low in phosphates, and yields practically no gelatin.

In the order of their value for producing glue of good color and test, they may be classed as green or fresh bone, steam, pickle, country and junk bones.

Green bone, as its name implies, is the fresh bone direct from the butcher, and consists of the heads and parts removed in preparing the carcass for market. To prevent deterioration it must receive immediate attention.

Steamed bone or packer bone is fresh bone which has been subjected to a preliminary cooking by the packer, perhaps before the complete removal of the flesh.

Pickle bone is somewhat similar to steam bone, but having been in pickle requires more careful washing to remove the added salts.

Country bone is the scrap from the small butcher shops and varies considerably in quality.

Junk bone is what its name signifies—old, dry or partly decomposed bone, anything the junk dealer may pick up.

The following tables, supplied through the courtesy of Mr. Heicke of Armour & Co., show average yields of glue, grease, and

tankage obtained from various market grades of raw materials over a period of about 20 years.

TABLE 42.—YIELDS OF GLUE, GREASE, TANKAGE AND PER CENT OF WATER IN HIDE STOCK

Raw material	Water per cent	Glue per cent	Grease per cent	Tankage per cent
Ossein, dry.....	10	70-80	.....	5
Calf stock gr. salted.....	30-40	16	2.00	9
Calf stock gr. limed.....	50-70	14	1.00	5
Calf stock gr. dry.....	10	35-40	1.00	5-10
Calf splits gr. limed.....	50-70	14	1.00	5
Kipstock gr. salted.....	30-40	18	3.00	8
Cattle hide stock gr. salted.....	30-40	18	3.00	10
Cattle hide stock gr. limed.....	50-70	14	2-4	8
Cattle hide stock dry.....	10	35	1.00	5-10
Ears (cattle) gr. salted.....	35	13-14	4-5	5
Ears (cattle) gr. limed.....	50-60	12	2	5
Ears (cattle) dry.....	10-15	35	1-2	10-20
Hide splits gr. limed.....	50-70	14	.....	5
Rawhide dry.....	10	40-50	.....	5
Cotton pickers dry.....	10	50	1.00	8
Lace leather.....	40	25	12-15	5
Sheepskin gr. limed.....	60	7.00	7.00	5-10
Goatskin gr. limed.....	60	7-9	1-2	7
Horsehide gr. salted.....	40	12	5	10-20
Buffalo hide dry.....	10-20	45-50	2	10-20
Alligator hide gr.....	30-40	40	.....	15-20
Rabbit skin French dry.....	10	50-55	.....	20
Rabbit skin Australian.....	10	50-55	.....	25
Rabbit skin English.....	10	50	.....	16
Rabbit skin Chappings.....	10	30-40	.....	20-30
Pig skin green.....	50-60	20-25	15	10
Pig ears gr.....	50-60	14	10-15	5
Fleshings cow, gr. limed.....	50-70	8-12	5-12	5-10
Fleshings calf, limed.....	50-70	7-8	2-3	10
Fleshings horse limed.....	50-70	6-8	1-2	15
Fleshings cow, dry.....	15	20-25	5-25	10-20
Fleshings German.....	10	27-33	1.00	.....
Fleshings Italian.....	12	40	2.50	20-30
Fleshings India.....	15	35	.....	20
Gara Gara Blanca dry S. A.....	10-15	40	3	15-20
Gara Nigra dry S. A.....	10-15	32	1	20
Chrome splits.....	40-50	25	.....	.....
Chrome shavings.....	40-50	18-20	.....	.....
Sinews green.....	50-60	16-18	2-3	6
Sinews salted.....	35-50	22-24	2-3	7-8
Sinews dry flint.....	10-15	40-50	3-4	10-15
Sinews dry bone (Calcutta).....	10-15	35-40	.....	30

In studying these figures it is necessary to consider the wide variations in composition due to: 1, the condition of the animals, caused by climate, region, feeding, age and handling; 2, the



TABLE 43.—YIELD OF GLUE, GREASE, TANKAGE AND PER CENT OF WATER IN BONE STOCK

Raw material	Water per cent	Glue per cent	Grease per cent	Tankage per cent	HN <sub>2</sub> in tankage per cent	Boiled
Cattle skulls green	40-60	12	10	28	2.5	open
Cattle jaws green	40-60	12	5	45	2.5	open
Cattle feet green	40-60	14	12	32	2.5	open
Cattle rib bones	40-60	10	10	30	2.5	open
Cattle knuckles	50	10	20	28	2.5	open
Cattle skulls dry	10	18-20	1	66	0.75	pressure
Cattle jaws dry	10	18-20	1	66	0.75	pressure
Cattle knuckles dry	10	18-20	1	66	0.75	pressure
Pig heads green	50-60	8	10	28	2.00	open
Pig feet green	50-60	14	14	20	3.00	open
Calf heads green	50-60	8	6	28	2.00	open
Calf feet green	40-50	8	8	30	2.00	open
Sheep heads green	50-60	6	10	25	3.00	open
Hornpiths green	35-40	18	..	32	2.5	open
Hornpiths dry	10-12	23	..	66	0.75	pressure
Country bones dry	10-15	15	2-4	50-60	0.75	pressure
Junk bones dry	10-15	15	2-4	50-60	1.00	pressure

condition and treatment of the stock in preparation for market; and 3, handling of the stock in the factory, which last will be treated in discussion of variations in process. The percentage moisture in the stock as received is the factor of widest variation and is indicative of the amount of concentration to which the stock has been subjected in preparation for transportation and storage. "Bone dry" condition of stock means roughly 10 per cent moisture except in the presence of appreciable quantities of flesh, when the moisture content runs higher. The dry cattle skulls, jaws and knuckles referred to in Table 43 have been grease extracted and dried before being marketed.

*Secondary Raw Materials.*—Water is undoubtedly the most important of all secondary raw materials of the glue maker, the amount used often running into millions of gallons per day. As to quality, the best is none too good, and for the gelatin maker distilled water is almost a necessity. In the washing process described later it is necessary to have water of low total salt content to obtain the maximum swelling. This is more important by far than to have the water "soft" or low in lime. The ordinary softening processes are of value only in so far as they produce a bright and sparkling water or reduce the bacterial content if coagulation methods are used. The presence of

bacteria in the final wash water is to be guarded against, for practically neutral glue stock is an excellent medium for bacterial growth, and if kept for any time after washing, the stock is bound to deteriorate to a certain extent. It is therefore often desirable to sterilize the water, and any of the methods in common use on potable waters are applicable. It should be borne in mind that such substances as ozone and chlorine harden the stock, and therefore only the minimum amount necessary to accomplish the purpose should be used, and any unused residue disposed of by aeration or chemical treatment before the water is ready to use in the factory. In the absence of organic matter (which may consume appreciable quantities of oxidizing agents) a fraction of a part per million, if left in contact with the water for a sufficient length of time, will produce practically complete sterilization.

For the actual boiling of the glue, distilled water is always to be preferred. Any salts in the water will be concentrated during evaporation and remain in the finished product to the probable detriment of the appearance. If the liquors are drained off at say 5 per cent concentration, that means that there will be nineteen times as much mineral matter added to each pound of glue as there is in each pound of water.

Air is another important secondary raw material. As about a ton of air is generally required to evaporate the water from the jelly containing a single pound of dry glue, the quantities handled are enormous. Other than situating the air intake so as to obtain as pure air as possible, nothing is done in the way of purifying or preparing this raw material. The advantages and possibilities of purification will be discussed in the treatment of the drying process.

Sulphur dioxide is used in the acid treatment and for bleaching. It is generally produced in the plant by burning sulphur in cast-iron furnaces with a slight excess of air. This excess of air is necessary to minimize the sublimation of sulphur under the heat produced by the combustion. The gas may be led into pottery lined absorption towers for the production of a dilute solution which may be used direct or after further dilution. This liquor is generally stored and transported in wood. Sulphur dioxide gas is piped direct from the burners to the storage and treating tanks where it is blown into the liquors in the purification and bleaching processes.

Muriatic acid is used for the acid washing of the stock and for acidulation of bone in the production of ossein. So far as known it is never produced by the glue maker, but is often regenerated from the leach liquors.

Lime and other alkalies are used in the hydrolysis of the stock. The lime may be purchased either as oxide or hydroxide and made into a thin paste or milk which should always be thoroughly cool when used. It is also used in the formation of the calcium phosphates which are a by-product of the ossein industry.

## II. MANUFACTURE

### 1. Hide Glue.—*Preparation and Preservation of the Stock.*<sup>1</sup>—

Hide stock may be received from the butcher green, or fresh and untreated. If it is not to be used immediately it must be preserved, otherwise putrefaction will soon destroy its value. Salt, lime and desiccation are commonly used. If the stock is piled alternately with layers of salt, it will give up the greater portion of its water to the salt and become shrunken. If after thorough salting this stock is partially dried and stored it will keep almost indefinitely with no change other than a slow hardening which disappears on careful washing and liming.

Partially limed stock may be stored by piling with sufficient lime paste to replace that used up in the slow hydrolysis which continues even in the absence of drainable water, but storage must not be continued too long or losses of a serious nature will take place.

Complete desiccation of unsalted and unlimed stock results in a hardness which is but slowly removed. Most of the common so-called chemical preservatives have not been found satisfactory if used alone or with desiccation, but in conjunction with salt or lime they are often valuable.

The United States government requires that all hides entering this country be thoroughly sterilized to prevent the spread of disease and have recently published specifications for this purpose.<sup>2</sup> The Regulations prescribe either treatment with hot water or milk of lime, both of which are stages of the glue making process. Heat, if applied for a sufficient length of time, of course,

<sup>1</sup> See bibliography at end of chapter for all references.

will give good disinfection, but the lime treatment is of very doubtful value, many bacteria thriving in lime liquors, as will be shown in the discussion of the liming process.

*Soaking and Washing.*—Whether green or dry, the first treatment given the stock is a thorough washing with water. With green stock this is for the purpose of removing all possible blood and dirt which would injure the color of the finished product. Dry stock is soaked until thoroughly softened and then washed until the salt is completely removed. It has already been shown that practically all substances produce some changes in the physical properties of gelatin. The same is true of the glue stock. In general, any neutral salt prevents the fullest swelling in water, and hinders it very markedly in the liming process which follows, resulting in a slower and less uniform liming.

The washing is carried on in machines similar in principle to the ordinary family washing machine, and of almost as great a variety of construction. Those more commonly used are as follows:

The *cone mill*, *log mill*, or *roller mill* consists of a large tub twelve or sixteen feet in diameter containing a central stationary upright post. To this is fixed the apex of a wooden cone, the length of which is approximately the radius of the tub. To the conical surface are fixed tapered strips of hardwood about four inches square at the large end and equally spaced, producing corrugations for the purpose of giving a kneading effect. The shaft passing through the cone is attached by a drag to an overhead drive beam which causes it to revolve around the tank with a rolling motion. Water is fed in from above either continuously or intermittently depending upon the quantity of substance to be washed out. Perforated strainers or screens are inserted in the sides or the bottom of the tub and the flow of waste water through these controlled with valves.

The *tumbler* or *barrel mill*, consists of a barrel mounted horizontally on its axis, with baffles on the periphery to keep the stock from sliding and carrying the stock part way around the mill, thus causing it to drop through the wash water with which the mill is filled. The stock and water are introduced through an opening in the cylindrical side of the mill, which is closed during rotation.

The *hollander* or *beating engine*,<sup>3</sup> more generally known in connection with the paper industry, consists of a shallow ellip-



tical tub with a vertical central partition reaching perhaps two-thirds of its length. Extending from this partition to one side is a horizontal revolving cylinder, with longitudinal blades mounted on its periphery. The cylinder can be raised or lowered to adjust the distance between the revolving blades and a set of stationary blades mounted on a raised portion of the tub bottom under the cylinder. The rotation of the cylinder squeezes and rubs the stock through between the two sets of blades and at the same time propels the water around the tub. On the opposite side of the partition a revolving cylindrical screen with central drain removes the wash water.

The *half-round mill* may most easily be described as like the paddle wheel of a stern wheel steamer mounted in a half barrel lying on its side. A perforated false bottom controlled with a cock is provided for draining off the wash water.

These four representative types may to a certain extent, be used interchangeably. The cone mill, which produces a combination of rubbing, kneading and washing can be used on almost any kind of hide stock. In the tumbler the pounding and kneading predominate and it is, therefore, more suitable for hard or thick stock. In the hollander the rubbing predominates and it is most serviceable for loosening foreign materials which adhere rather firmly to the fibers, but its construction prohibits use on heavy or non-uniform stock. The half-round mill gives a simple agitation and rapid circulation of water suitable only for finely divided and light stock.

*Liming.*<sup>4</sup>—Skin consists of several distinct layers. First, the outside surface consists of the *epidermis*, *epithelium* or *cuticle*, which is albuminous in its nature and is of no value to the glue maker. The hair, nails, and hoofs are epidermal formations and are related to the epidermis in composition. Under the epidermis is the *hyaline* layer, a glossy structure which produces the grain surface. The *corium*, *derma* or *cutis* lies beneath this. This is the true skin and consists of bundles of interwoven fibers cemented together by a somewhat more soluble substance. The *corium* consists principally of collagen, the glue forming substance, along with proteins of a mucinous nature. The skin is attached to the animal by the *panniculus adiposus*, a network of connective tissue and fat cells. This is the major constituent of fleshings.

The purpose of the liming process is to dissolve out the albu-

minous and mucinous constituents. By this means the hair and insoluble parts of the epidermis are loosened and a portion of the fat (probably principally that in broken cells) saponified. Both albumin and mucin are soluble in alkali, forming alkaline albuminates and other hydrolysis products. Alkaline albuminates can be precipitated by acids, but will also redissolve in acids. The compounds formed from mucins, if precipitated by acids become insoluble and, therefore, must be completely removed before the subsequent acid treatment if a bright glue is to be obtained without excessive clarification. Dilute alkali also dissolves collagen, but to a lesser extent. The principal action here is to produce a swelling by absorption of water.

Successful liming, therefore, consists in a careful control of alkaline hydrolysis so that the albuminous and mucinous materials are practically completely dissolved without allowing the hydrolysis of the collagen to progress far enough to cause appreciable solution. Saturated lime water has a very suitable alkalinity for the purpose (0.67 grams of hydroxyl per liter). As alkali is used up in the reactions involved, the use of clear lime water would require repeated changing to maintain the desired concentration. Commercially, therefore, a suspension is used instead, so that as rapidly as the hydrate is used up it will be replaced by solution of the excess in suspension, and the alkalinity maintained at practically a constant value. Also lime is the cheapest alkali and in the concentration handled the Baumé hydrometer readings approximate the percentage concentration. Calcium hydrate is more soluble in cold water than in hot water, so that there is a partial compensation for increased hydrolysis with warmer weather in this automatic decrease in concentration.

This ease of controlling hydrolysis is partially offset by the fact that some bacteria present in the stock are not killed by the alkali, but continue to multiply in the stock and finally find their way into the lime solution itself. Counts of several million bacteria per c.c. of lime liquor have often been made. The bacteria are apparently acid formers and use up a part of the lime to form salts, which in turn inhibit to a certain extent the alkaline swelling of the stock. Bacterial growth can be minimized by frequent turning over of the stock, and better yet by also replacing the liquor with fresh milk of lime. Occasionally glue made from stock which is infected will show a higher test

than that made from stock limed under more carefully controlled conditions, but the yield is always low, indicating that the bacteria have developed at the expense of the more highly hydrolysed portions of the glue stock.

Bacterial decomposition can be overcome by the use of other alkalies at concentrations which will produce sterilization. However, increased alkalinity decreases the swelling, and, therefore, the penetration of the alkali to the interior of the stock is somewhat slower than would be expected. At the same time hydrolysis of the exterior is more rapid because of the increased concentration. With certain kinds of stock, however, if frequently turned and carefully watched, very satisfactory results can be obtained.

The stock is often run through shredding or cutting machines to give the pieces a more uniform size and therefore produce more uniform liming and extraction. It is then thrown into wooden or concrete vats containing the alkaline liquors and turned as often as is necessary to insure even distribution of alkali throughout the stock. Several complete changes of alkali are used. The total amount of lime used is something like 10 per cent of the weight of the stock. If caustic soda is used much less is required. The total time in soak is dependent principally upon the thickness and kind of stock and varies from 30 to 60 days. With the use of soda the time is very materially shortened.

Bleaching agents and preservatives are sometimes used at some stage of the liming process with beneficial results, but they introduce disturbances which will be discussed with a later process. Phenolic compounds, bleaching powder, and sodium peroxide are among the favorites.

Along with the other hydrolysis products formed during liming there is given off a small quantity of ammonia. However, the concentration occurring in the lime liquor at any one time is always less than one tenth of one per cent.

*Washing and Deliming.*<sup>5</sup>—After the liming has progressed until the inner portions have been practically cleared of their mucins and the stock shows a fairly uniform swelling and transparency, it is considered thoroughly limed. The alkali and its hydrolysis products must now be completely removed. This is done by returning the stock to the wash mills and washing with clear water.<sup>6</sup> At this stage the stock swells still further in consequence of the removal of the salts, but to accomplish com-



plete removal would require a prohibitive length of time. As soon as the wash waters run clear, dilute acid is added with the water to further increase the swelling and hasten the removal of the remaining salts.

The maximum swelling of gelatin occurs in a solution containing about 0.0025 grams of hydrogen ion per liter. At this point gelatin will absorb something like fifty times its weight of cold water. To obtain such a low concentration uniformly throughout a thick piece of glue stock by use of such very dilute acids would be practically impossible, so concentrations probably a hundred times greater are used at the start and the stock allowed to remain in contact with this acid until the last parts to be reached have attained a concentration somewhat above the desired 0.0025 normal and then the washing continued with clear water until the average concentration is about 0.0025 normal. Of course, this means that the outer layers are below this value and the inner layers above it, but by this time the salts present and formed by neutralization have been pretty well dialysed out and the stock appears to be uniformly swollen. It is still, however, far short of reaching the theoretical maximum swelling of gelatin.

The most commonly used acids are sulphurous and hydrochloric. Sulphurous acid, besides producing a better swelling, has both bleaching and antiseptic action, and would perhaps be considered preferable from the manufacturer's standpoint, but it has the disadvantage that any appreciable amount of sulphites are prohibitive in a food gelatin and will have to be removed later in the process.

Hydrochloric acid contains iron and often also arsenic. The iron is objectionable on account of its effect on the color and arsenic is, of course, objectionable in a food.

*The Boiling Process.*—The term boiling as here used does not necessarily imply actual ebullition, but rather a gentle cooking at any desired temperature. The primitive method of boiling glue was to heat the stock over an open fire with a large quantity of water until practically all had gone into solution. The time necessary to hydrolyse the last part of the stock was so great that much of the glue first dissolved had become hydrolysed into cleavage products of little or no adhesive value.

As the boiling is the most important single step in the process an attempt will be made to analyze the factors entering into it.



It is realized that the desirable and undesirable ones are so interwoven that a clear exposition of their control will be difficult.

Since extraction is simply hydrolysis plus solution and the deterioration of the glue liquor is also simple hydrolysis, it follows that both are time-temperature concentration reactions, and unseparable except that the latter may be considered a later stage of a progressive hydrolysis. Briefly enumerated, the following conditions are to be desired:

(1) *Rapid extraction.* Cutting down the total time of boiling reduces the total time the dissolved glue is in solution and allows proportionately smaller secondary hydrolysis.

(2) *Extraction at as low a temperature as possible.* The swollen stock contracts very noticeably with heat, and as the water is thus given up, rate of solution—all other things being equal—must of necessity suffer, for not only will the concentration of the dissolved glue in the stock be greater, but also the rate of removal through the stock will be less. due to the stock being so much denser.

(3) *High concentration of resulting liquor.* Hydrolysis in solution is proportional to the amount of water present to cause the hydrolysis, so that high concentration of the liquor is desirable even when the liquor is merely standing or being handled in process. No matter how rapidly or how carefully evaporation in the vacuum pan is conducted, deterioration is bound to occur during the operation. Also the volume of liquor handled is in reality the limiting factor of the capacity of the plant, and increased concentration at this point generally means increased plant capacity.

(4) *Continued presence of fresh water or dilute liquor in contact with the unhydrolysed stock,* so that the maximum rate of solution may be obtained. As pointed out in (3), solution is more rapid if the solvent is dilute. Agitation of the stock, and circulation, or percolation of the water are desirable means of insuring this condition.

(5) *Immediate and complete removal of dissolved glue from the zone of highest temperature.* As heat must be continuously applied to the extraction vessels, the liquor carrying the heat to the stock will always be slightly higher in temperature than the stock itself, and if this liquor contains glue in solution, injurious hydrolysis must of necessity occur. Immediate removal of the dissolved glue to some other container will prevent its being

used as a means of heat transference and at the same time allow a certain amount of desirable cooling to take place. All this argues that a continuous counter-current scheme of boiling would be very desirable.

(6) *Little or no pressure or load on the stock being boiled*, for pressure, even if only momentary, squeezes out the liquor and by so doing slows down extraction. It has been proven that squeezing of any nature is detrimental to rapid extraction, due principally to the fact that when water is squeezed out, it is subsequently replaced but slowly.

(7) *The production of a clear liquor*, so that drastic mechanical and chemical treatments will not be necessary in the subsequent clarification.

It will readily be seen that in order to obtain any of these conditions, some of the others enumerated must be sacrificed. For example, it is difficult to understand how a rapid extracting and a low temperature may be maintained at the same time. If a high concentration of the liquor is to be obtained, then the provisions requiring the continued presence of fresh water and the immediate removal of the dissolved glue will probably have to be sacrificed. To reduce the pressure on the stock being boiled, the latter may be distributed over a considerable area, but in that case the heat losses are increased. To obtain a clear liquor, motion during boiling should be avoided, but this is difficult if fresh water is to be kept in contact with the unhydrolyzed stock or if the dissolved glue is to be removed as soon as formed.

Generally the boiling of hide stock is conducted in vats perhaps six or eight feet in diameter and somewhat less in depth. Heating coils, preferably for closed steam are placed on the bottom, and a perforated false bottom used to cover them and prevent actual contact with the stock. This bottom is often covered with a layer of excelsior or other coarse filtering material. An opening with well gasketed cover may be provided in the bottom of the vat for easy discharge of the residue remaining after boiling.

The stock is dumped into the vat until almost full, then covered with hot water. Heat is then applied and the temperature maintained at perhaps 140°F., for several hours or until the liquor has dissolved about 5 per cent of its weight of glue. The liquor is then drawn off through a valve in the bottom and fresh water added. This time and heat is maintained 10 or 15° higher and after about the same time this liquor is drawn off as before.

Four or more such "runs" are made, the last one often being at a temperature of 212°F.

A study of the properties of the different glues resulting from a very large number of water changes has shown that the first glue to be dissolved is that which was so highly hydrolysed in liming that raising the temperature is all that is needed to bring it into solution. Time for hydrolysis is not required. Due to overliming of certain portions of the stock, this may be comparatively low in both jelly and viscosity tests, and it has a low melting point. In subsequent runs the test rises at first, the jelly test reaching a maximum almost immediately with the viscosity following closely behind. Then the tests drop gradually until the glue is all extracted. If quantities of water added and

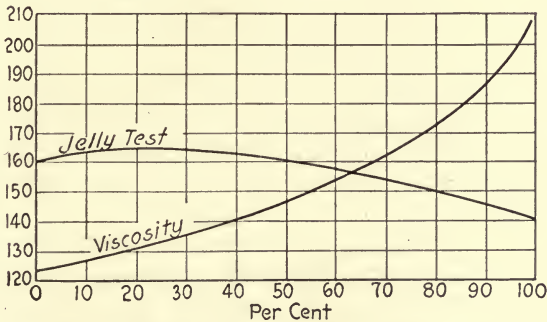

FIG. 48.—Average tests of glues made by repeated additions of water.

removed are so frequent that in effect we have removal of the glue as soon as dissolved, we are practically removing the glue at its melting point and as the heat is continuously increased, the melting point and viscosity continue to increase even though the jelly test is dropping. The only explanation for such a phenomenon is that in the *ordinary* progressive boiling, the hydrolysis of the glue already in solution, during the time the liquor is allowed to be in contact with the stock for further concentration, is responsible for the gradual decrease of viscosity regularly observed.

Figure 48 illustrates this temporary rise in jelly test and the continuous rise in viscosity.

Although far from satisfactory, the use of from four to eight changes only of water has been considered to meet many of the above stated requirements to a much greater extent than the



old single boiling method. Many manufacturers have introduced other changes tending to increase the rate of extraction by attempts to improve the circulation in the boiling vat. For example, a wide perforated vertical tube is placed in the center of the vat before the stock is dumped into it. This unquestionably increases the rate of circulation, but the liquor coming in contact with the heating coils is the concentrated liquor gravitating from the stock before it has a chance to mix with the more dilute main volume of liquor.

Agitation by the introduction of a slow current of air has been found to be of considerable help. It has the disadvantage, however, of increasing markedly the rate of evaporation of the liquor, thus necessitating a greater steam consumption and a higher temperature differential at the coil surfaces with its consequent deteriorating effect. Simple hand stirring by means of wooden paddles has proved beneficial.

Considerable ingenuity is displayed in the patent literature in the design of widely varying mechanical containers for keeping the stock or liquor in motion during extraction. In many of these steam is used in place of hot water and the process is made continuous.

Cormack<sup>7</sup> packs his stock in a centrifuge and subjects it to condensing steam. The squeezing effect of centrifugal force must certainly have a hindering effect, but the glue would be removed as soon as dissolved, thus minimizing deterioration.

Thiele<sup>8</sup> has patented what is in effect an enclosed steam jacketed percolator, spraying very hot water over the top and allowing it to drain off immediately. No provision is made for insuring thorough percolation through the more densely packed portions of the mass.

Mauerhofer<sup>9</sup> distributes the stock in thin layers over perforated plates and blows steam upon it from a central perforated pipe. The addition of a water spray at the top would overcome to a certain extent the lack of heat conduction from steam to the covered portion of the stock, which has always been the drawback in such means of extraction.

Lehman's patent<sup>10</sup> for the use of an Archimedes' screw for keeping the stock in motion in the liquor neglects a good opportunity for making a true counter-current extraction. He simply immersed the screw in the liquor.

Upton<sup>11</sup> uses a rotating horizontal cylinder containing per-



forations on a part of its periphery and provided with a shutter for prevention of the escape of steam. Steam is admitted through a central perforated pipe and the liquor formed from the condensed water allowed to drain out through the perforations as soon as produced. The author has used an apparatus having some elements in common with this extractor and has succeeded in obtaining remarkable increases both in test and completeness of extraction.

These methods all have what was formerly considered a very serious objection, namely, the agitation causes suspension in the glue liquor of materials which would otherwise remain in the residue, thus diminishing the clearness of the liquor as drawn from the extractor. The careful and effective filtration or clarification necessitated have been worked out, thus making commercially acceptable those processes which give material increases in value over vat process liquors.

Fine shredding of the stock, by increasing the surface exposed to the water hastens the extraction materially. As the swollen stock ready for boiling is difficult to shread without squeezing out much of its water, it has been found more satisfactory to do the cutting earlier in the process, even though the washing losses are materially increased thereby.

*Clarification<sup>12</sup> and Filtration.<sup>13</sup>*—The suspended materials contained in the liquors as received from the boiling floor consist of undissolved organic matter, albumins and mucins, lime soap and grease as well as some hair and mineral particles, such as lime or bone fragments.

A considerable portion of this foreign material can be removed by screens or coarse filters.

The use of the centrifuge has found favor for the removal of some of the heavier substances, but unless the liquor is extremely dilute the volume handled per machine is very limited. Also if the liquor is practically neutral, lime soaps and mucins seem to be churned in rather than separated, and some liquors foam very badly.

Formerly filter presses were very popular, but they are largely giving way to gravity or mild pressure filters. The retention of the fine particles on the filtering medium seems to be a species of adsorption and requires an enormous surface of exposure rather than a dense fine aperature medium. Both the mucinous substances and lime soaps are exceedingly sticky, and, especially

if under the pounding influence of a pump stroke, they soon completely fill the pores of any dense substance and cause blocking and breaking through.

The mucinous impurities carry nearly the same electrical charge on their colloid particles that gelatin particles carry. On this account the protective action of the gelatin narrows very greatly the limits within which good filtration can be accomplished. The substances to be filtered out appear all to be negative, and the use of fullers earth which is strongly negative does not appreciably improve the appearance of the glue. On the other hand, if alumina, a strongly positive substance, is used, the liquor will run clear but the filter will block almost immediately. Charcoal is almost neutral and will produce successful filtration for a considerable time. However, the filtering substance preeminent for this purpose is cellulose. Being very slightly negative it holds the particles without holding the glue, and although the actual surface per unit of volume is probably much less than with charcoal, the filters are so constituted that they will hold a maximum amount of precipitate before blocking. A convenient form of cellulose is a good grade of cotton paper pulp. Many different forms of filters for holding such pulp are obtainable, but those allowing for a loose packing of the pulp on the intake surface will provide a mat of considerably longer life than if the filter mat is required to be densely packed throughout.

Although certain liquors can be filtered perfectly bright, many of them will cloud on cooling and practically all of them cloud on concentrating. To remove this precipitated or precipitable material and thus obtain a brilliant gelatin it is necessary either to produce a colloidal coagulation or to cause the formation of a precipitate or aggregate which will collect and hold by forces allied to adsorption the objectionable substances.

The oldest and best known substance used for this purpose is egg albumin. The albumin in water solution is added to the comparatively cool liquor and the temperature gradually raised until coagulation takes place. The whole is then allowed to stand for the separation of the curd or coagulum, which often requires hours. The clear liquor is then siphoned off and filtered. The effect of the prolonged exposure to heat is a very serious objection and good egg albumin is expensive. Blood albumin can be used in a similar manner if the solution is kept sufficiently acid.

Among the more common of the inorganic precipitants used are: alum and lime to form alumina and calcium sulphate, or such acids as sulphurous or phosphoric which form insoluble salts with the alkaline earths. Recently silver salts have come into use for the removal of proteins and salts which are objectionable in photographic gelatins. The requirement in any of these precipitations is that the substances formed shall all be insoluble, or if not, either volatile or incapable of crystallizing out in the dried glue.

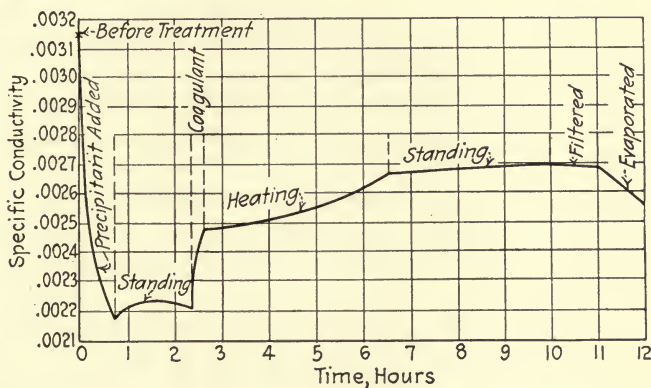

FIG. 49.—Specific conductivities of glue solution during clarification. (Reduced to 5 per cent concentration.)

There are only two really effective methods of controlling the reactions involved, namely by observation of the hydrogen ion concentration, or of the conductivity of the solution during the formation of the precipitate. The first of these has been the more common, using litmus as the indicator, but indicator color changes are valuable only in enabling one to repeat certain conditions previously observed, and make no allowance for changes in apparent acidity caused by amphoteric substances which may or may not be present. A low ash product is always to be desired and what the glue maker really wishes to know is at what stage of the precipitation the soluble salts reach a minimum. This is more easily determined by measuring the conductivity than by any other means. Ash determination and analysis tell the quantity and substances present which may form ash, but it does not tell whether they are combined as precipitates or as soluble salts. The conductivity method was found very satisfactory for answering this question and a series of observations on a



normal precipitation in the factory is shown in Fig. 49 to illustrate the distinctness with which such hidden facts stand forth.

Bleaching of the liquor with sulphur dioxide<sup>14</sup> is quite common. Other substances used are: sodium hydrosulphite, the basic zinc salt of formaldehyde, sulphoxalate, amalgams, and other strong reducing agents. A part of the bleaching effect seems to be due to reduction of organic coloring matter, while in the inorganic substances the change from the ferric to the ferrous state of traces of iron is often responsible for a marked improvement in color.

*Evaporation.*<sup>15</sup>—The liquors (with the possible exception of those intended for thin cut gelatins) are now sent to the vacuum pans. The types of evaporators used and suitable are so varied and so well known that detailed description is unnecessary. The double-effect is most commonly used. It is advisable to evaporate the dilute liquor in the low vacuum high temperature pan, and finish in the high vacuum low temperature side, thus using the gentler heat on the concentrated liquors and minimizing total hydrolysis.

Vacuum evaporation is more economical than alley drying, but it is also apt to be more harmful to the test. Exhaust steam, or at least very low pressure steam, should be used and the vacuum maintained at the highest possible point, so that the temperature may be maintained at the minimum consistent with rapid evaporation.

✓ Considered as evaporative apparatus only, pans are all practically the same, that is, one pound of steam will evaporate practically the same weight of water in any make of double-effect, other conditions being equal. However, the injury to the glue will be less in those which produce a high rate of evaporation while requiring the presence of only a small volume of liquor at any one time. This means a high evaporative surface-volume ratio, and adequate facilities for taking care of foam or priming and entrainment. Considerable space is generally allowed for the breaking up of the foam. Alkaline glues often foam badly on account of the presence of soaps. The presence of any insoluble substance tends to increase foam. The addition of substances such as grease which alter the surface tension will decrease very markedly the tendency to foam.

Various types of baffles and catchalls are introduced into the vapor space and lines to catch and return the entrainment, but



when one stops to consider that the vapor velocities are generally measurable in miles per minute, it is apparent that many of them are practically valueless. The Parmelee catchall is designed to use this very high velocity in the separation and removal of the entrainment by centrifugal force and is by far the most efficient design yet produced. This is shown in Fig. 50.

If dry glue in thin sheets is to be produced evaporation may be omitted or carried to a glue concentration of only about 5 per cent. To chill and handle a jelly of such low concentration requires that it be of the highest test. For lower grades the concentration may be pushed as high as 50 per cent.

Up to this stage in the process time has literally been money to the glue maker, for hydrolysis into products of less value has been going on continuously. The liquor can now be cooled and with the liquor at a low temperature and high concentration natural hydrolysis becomes much less marked. The lower temperature, however, is favorable to the growth of bacteria and preservatives are sometimes added at this time. The choice of a preservative is always a difficult matter. Of course they are only used in the lower grades of glues or in glues for special purposes. Practically all antiseptics cause either coagulation or peptization, for it is apparently from the hardening or dissolving action on the colloidal cell-membrane that the destruction of the bacterial cell results. Such harsh substances as mercury bichloride and formaldehyde cause the glue to become insoluble on drying. Phenolic compounds cause a marked drop in test and even the mild borax or boric acid affect the jelly test. Betanaphthol, cresylic acid, soaps, and sulphates of some of the heavy metals are often used, but none of them are without effect on the glue itself.

If sulphites are to be removed, some mild oxidizing agent such as hydrogen peroxide may be added at this time.

White glues are made by the addition of pigments before drying. To get a clean uniform color the pigment must be highly opaque and have what the painter might describe as tinctorial power. It must be fine and in perfect suspension. This is best insured by grinding in a colloidal vehicle.

Other substances are sometimes added at this stage in the process for the production of glues having special properties. For example, glycerin, sugar or tar oil impart greater flexibility. Calcium chloride, sodium naphthalene sulphonate, acids, and

chloral hydrate will prevent jelling and produce a liquid glue.

*Chilling and Spreading.*<sup>16</sup>—A method for chilling the glue liquor from the evaporator, still used to a considerable extent, consists in running the liquor into cooling pans of wood or metal

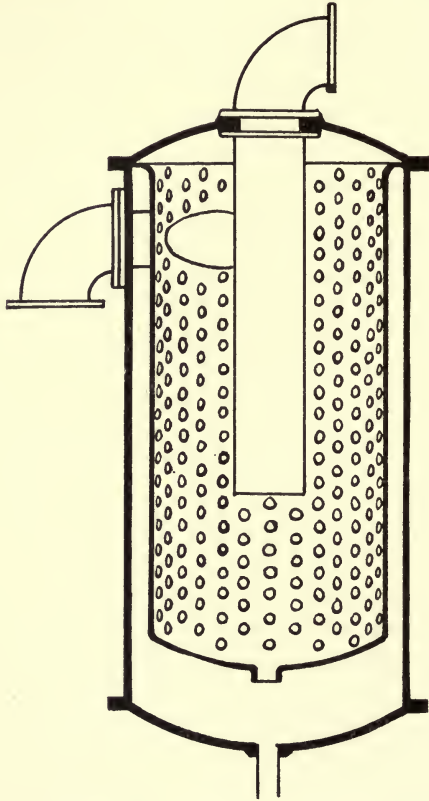

FIG. 50.—The Parmelee catchall.

and exposing to refrigeration until thoroughly set. The filling of these pans is a sloppy procedure, the chill room is seldom uniformly cooled, and condensed evaporation from the warm liquor keeps the room in a drippy foggy condition and often makes it a veritable incubator for moulds and bacteria. In fact it is impossible to keep things sterile and an occasional epidemic of liquefaction or low test is not unknown to the chill room of any factory. By means of proper circulation and careful conditioning

of the air the temperature and humidity may be so controlled as to at least prevent the spread of any infection accidentally introduced. Often running water is used for the preliminary chilling and it is common practice to have the rooms arranged so that they can be thrown open to the outdoors in winter weather.

The jelly is removed from the pans or trays by cutting, by immersing in hot water for a short time, or by exposing to steam. The pans are then returned to the chill room for refilling. The cakes are cut into sheets by machinery. The older type of slicing machines were similar in principle to the butcher's ham slicer and are still used for cutting very stiff jellies. Banks of thin knives operating in closed boxes (to prevent deformation of the jelly) were also used. By far the greater portion of the slicing, however, is done with tightly stretched piano wire, operating *en banc*, generally on some form of endless belt. The glue slices are laid out by hand, or "spread" upon frames perhaps three by six feet and covered with netting of cotton, zinc, or heavily galvanized wire. The scrap from these operations is gathered up, melted, the dirt settled out, and the clear liquor returned to the chill room.

As the chilling, cutting and spreading require a great amount of space and are messy and necessitate considerable manual labor, many devices have been designed for chilling the liquor on belts and transferring immediately to the frames. The Kind-Landesmann machine<sup>17</sup> has received rather wide acceptance in the last few years and is proving very satisfactory for all grades of glues and gelatins. It consists of a perforated pipe for distributing the liquor from the storage tank upon an endless rubber belt. This belt passes through a chilling tunnel kept cool by fan circulation of air from brine coils in a contiguous chamber. When the belt and glue appear at the opposite end of the tunnel the glue, now in a jelly form, is scraped off by means of a knife and falls upon a short transfer belt which in turn drops the sheet upon a frame which passes along under the transfer belt at the proper speed to receive the sheet. A knife is also provided for cutting the endless sheet into lengths to fit the frames. All the labor required is to put the empty frames into the machine and remove the full ones to the trucks for placing in the alleys. Not over fifteen minutes are required from the time the liquor is put on the belt until the jelly is on the truck. There is no scrap

to be returned, and as the jelly is not touched by hand it can receive no bacterial contamination from that source.

*Drying.*<sup>18</sup>—The glue receives its final drying in long tunnels or alleys so constructed as to receive trucks stacked with perhaps twenty of the frames. A track running the length of the alley guides the trucks through and the most approved practice is to have each alley long enough to produce complete drying and to have the air blown through counter-current to the direction of the progress of the trucks. This exposes the nearly dry glue to the dryest air and utilizes the almost saturated and much cooler air for the evaporation of moisture from the fresh jelly.

Steam coils are provided in some part of the intake duct for the purpose of heating the air and thus increasing its moisture carrying capacity. Low concentration jellies require shorter alleys and less time for drying than do those of higher concentrations. This is due to the fact that besides the simple evaporation of the water we must consider also the rate of conduction of moisture through the sheet of partially dried glue. As the high concentration jellies produce a thicker sheet when dry the last traces of moisture are driven off much more slowly. If the air is exceedingly dry a hard skin is formed (called case-hardening for want of a better term) which admits of only slow moisture conductance, and if progress through the alley is too rapid, the central portions of the sheet may actually melt and cause the sheet to warp out of shape. Such phenomena are common in the drying of many kinds of material. In lumber drying this case-hardening is the principal cause of checking.

As an aid to the study of conditions in the drying alley The Psychrometric Tables of the U. S. Weather Bureau (Bulletin 235) are invaluable. Figure 51 is a chart plotted from these tables. Air at any given temperature is capable of holding a definite amount of moisture. If it is exposed to an excess of water it absorbs moisture until this amount is reached, when it is said to be saturated. These amounts are shown in grams per cubic foot on the upper curve marked 100 per cent saturated. The natural moisture content of the air is generally expressed in percentage saturation, sometimes called relative humidity. This expression signifies that the air contains only the given percentage of the total possible moisture weight at that temperature. If two thermometers are placed in a strong current of air, one of them having the bulb surrounded by a wick satu-



rated with water, they will often register widely different temperatures. The dry bulb records the actual temperature of the

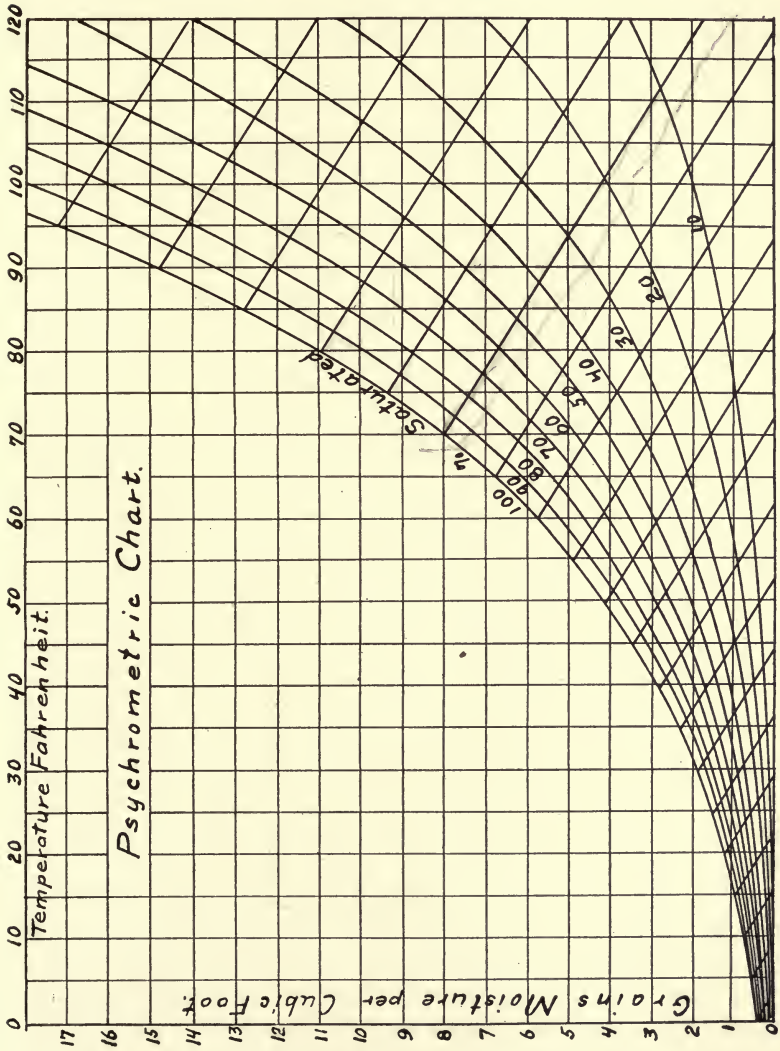

Fig. 51.—Psychrometric chart.

air, while the wet bulb records the temperature to which the air will drop in saturating itself with moisture.

For the purpose of illustration, consider air at 92°F. with a wet bulb temperature of 70°. This is 32 per cent saturated and contains 5 grains of moisture per cubic foot. In traveling

through the alley it will take up moisture, giving up the heat necessary to evaporate the water from the glue and consequently cooling itself to a lower temperature. If the alley were infinitely long and thoroughly insulated different points might record conditions as follows:

Dry bulb temp., °F.	Wet bulb temp., °F.	Percentage saturation	Grains of mois- ture per cubic foot
92	70	32	5.0
85	70	47	6.0
80	70	61	6.7
75	70	78	7.3
70	70	100	8.0

The conditions have followed the oblique line ending at 70°F. on the saturation curve. This oblique line or cooling curve covers all conditions which will show a wet bulb temperature of 70°. The wet bulb temperature can be changed only by a change in the *absolute* heat content of the air. If the alley were short, say 100 feet and the last truck of glue freshly added, the temperature of 75° might be that of the exit air in place of 70° as in the infinitely long alley. However, the fresh glue would have a temperature of 70° irrespective of the length of the alley. In other words, provided there is no skin on the glue, *it will assume the wet bulb temperature of the air*, due to the cooling effect of evaporation, no matter what the actual temperature of the air.

Since the alley walls conduct a certain amount of heat, as soon as the air drops below outside temperature it begins to take up heat from the surrounding walls. The addition of heat is represented on the chart by a horizontal movement to the right from any given point. This addition of heat from the alley walls causes a rise in both the wet and dry bulb temperature, which would show on the chart as an upward deflection from the normal cooling curve, never amounting to more than a few degrees, however. Under the trying conditions of high summer humidity, even two degrees rise may cause considerable damage. This is the explanation of the apparently anomalous observation that in hot weather the glue will melt down first in the coldest of two alleys receiving their air from the same source. It is simply a case of the alleys being loaded to the point that the wall con-

duction becomes appreciable and raises the wet bulb temperature above the melting point of the glue.

It is impossible to make a general statement as to what is the most economical length of drying alley. The correct construction equipment and operation for any specific conditions can be easily worked out from the psychrometric tables, however. In the winter time when the air is dry, short alleys are all that are required for the actual drying, but as the long alley produces a slow humidity gradient, it offers the advantage of more uniform drying and lack of case-hardening and warping. Much shorter alleys are required for low gravity jellies (thin cut), but on account of the low melting point of dilute jellies, it is difficult and often impossible to handle them in the summer time. Also, on account of the much greater space required for drying a given weight of thin cut material, it is desirable to make this grade of goods in the winter when the alley capacity is at a maximum.

Thick jellies always require a long alley and only a moderate air velocity for the minimizing of case-hardening, and even then it is often advisable to allow the very thick cut glues to stand on the trucks in an open room for the final drying.

It is evident that economy in operation consists in evaporating the maximum weight of water with a given quantity of air, and yet the unpardonable sin is to put fresh glue into an alley which is already delivering saturated air. In its simplest terms the problem consists in putting all the heat possible into the air without danger of the wet bulb temperature reaching the melting point of the fresh jelly, also the addition of new trucks and withdrawal of old ones so gradually and continuously that the exit humidity is only slightly below saturation, and the regulation of air velocity to alley length such that smooth sheets of fairly uniform moisture content are produced.

If the alleys are equipped with individually controlled fans and heating coils, and hourly determinations of the wet bulb temperature of the changing outside air are made, all that is necessary for complete control is to note from the chart the exact amount of heat that may be safely added to an alley containing glue of any given melting point. The given runs and concentration of solutions in any well operated factory are consistent enough that the melting point of any given grade of product is easily learned.

As the weight of water evaporated by a given weight of air sometimes drops as low as a quarter of one per cent (of the air

handled), and as all air contains an appreciable quantity of dust, smoke, etc., the necessity for cool pure air is almost as important as that for cool pure water. The ideal location for a factory to make a thin clear product would be at a high altitude far from the dirt of a city. Tyndall<sup>19</sup> over fifty years ago found that 50 per cent of the total dust of the atmosphere is contained in the first 100 feet above the earth's surface, due largely to the moisture condensing effect of dust, and in turn the dust-holding properties of moisture.

This indicates clearly that the air intake should be situated at as high a point as possible and where the prevailing winds will not bring smoke from nearby stacks.

Even under the best conditions the amount of dust and accompanying bacteria deposited on the glue by the enormous volume of air is considerable and it is almost certain that at some time the trade will demand edible gelatin which has been dried with artificially purified air. The washing and conditioning of air for public buildings of all sorts is becoming quite common. As high as 98 per cent of the dust can be washed from the air in efficiently operated scrubbers.

The removal of moisture from the air used in iron blast furnaces has been practiced for years. The Gayley dry blast process, the first and best known air drying process, is dependent upon refrigeration for removal of the moisture. How complete this can be is shown by the small saturation values at low temperatures on the psychrometric chart. Other processes are based upon the use of some dehydrating agent which is regenerated by heat in another stage of the process. For moderate moisture removal this class is generally more economical than refrigeration. Figure 52 illustrates the moisture absorbing properties of solutions of calcium chloride as an example of the possibilities of this class of moisture removal methods.

After the trucks are removed from the alleys, the sheet glue is stripped from the nets by hand and in most cases broken up by means of crushers, generally of the hammer mill or disintegrator type. This produces the *flake glue* of commerce. It may then be ground in a rotary fine crusher to a coarse powder. For many uses, such as wall finishes, it is again ground to an almost impalpable powder. Special forms such as *sheet*, *strip*, and *noodle glue* are made by cutting the jelly to such dimensions that the pieces when dried will attain the desired shape and size.



Many methods of drying glue have been tried as substitutes for this laborious process of chilling, spreading, and alley drying. Vacuum dryers which spread the liquor in a film over an inter-

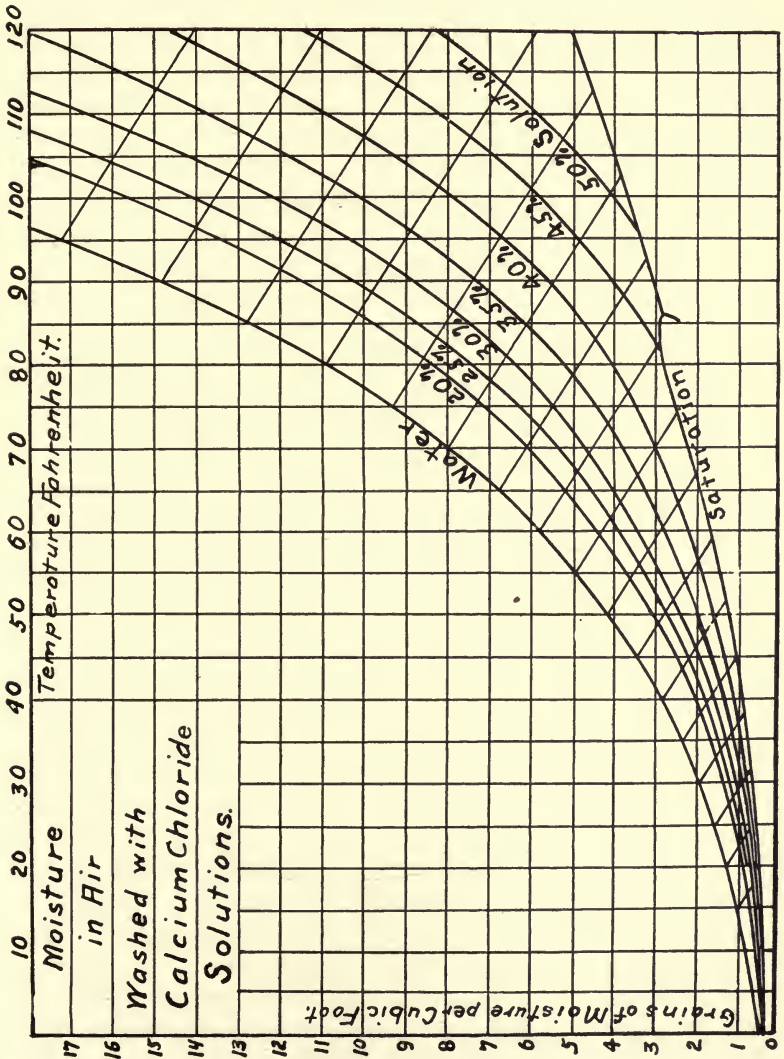

FIG. 52.—Moisture in air washed with calcium chloride solutions.

nally heated rotary drum are used for many products but have met with little favor in the glue and gelatin industry. However, steam-heated rolls evaporating directly into the atmosphere are finding limited use on low grade glues. Atomization of the

liquor into a rapidly moving current of very hot air<sup>20</sup> is a successful method for drying such products as milk, but the method has been applied to glues and gelatins to only a limited extent.

Market glue contains from 8 to 16 per cent moisture, according to the quality. Other conditions being equal, the higher grade glues contain the higher percentage of moisture, being more hygroscopic by nature. The physical properties of the glue are apparently dependent, in certain characteristics, upon this hygroscopic moisture. If it is driven off, the solubility and test suffer in proportion. Completely dehydrated glue is practically insoluble and in its action resembles untreated glue stock more than finished glue. The tensile strength of the dry glue is also closely allied to the moisture content. The low grade glues, which have low tensile strength when dry, are exceedingly strong at certain stages of the drying. This is easily shown in the making of a frost-crystal surface on glass. The glass is ground and coated with a heavy solution of a low grade glue, then dried in an oven. During drying the glue film shrinks and curls away from the glass, pulling with it a part of the glass, and producing in this manner the appearance of crystals often several inches long. This glue, which when partially dry was strong enough to strip large areas from the glass, may fall apart of its own accord when allowed to dry slowly in the air.

**2. Bone Glue.**<sup>21</sup>—Since in many respects the making of bone glue is similar to that of hide glue, for the sake of brevity only those processes where there is a marked difference in procedure will be discussed. Green bone, immediately upon receipt is passed through a rotary crusher, then over a screen to separate and save the fine particles which might otherwise be lost in process. It is then thoroughly washed in a barrel mill until all blood, etc., is removed and finally washed in dilute sulphurous acid. The purpose of this preliminary treatment is not only to remove all color left by the blood but also to keep the stock sweet and minimize development of rancidity in the fat.

*Degreasing.*—In this condition the bones contain roughly 50 per cent moisture and 5 to 20 per cent grease, the composition, of course, varying according to the kind of bone. If this bone is stored in the raw condition the fats will slowly oxidize in the air thus reducing the value of the stock. On this account it is customary to remove as much as possible of the grease and moisture before storage. This may be accomplished by giving the

bones a short preliminary boiling which removes all but about 1 per cent of the grease, after which they are spread out and dried, yielding a product similar to the commercial "packer bone."

Shin bones, after such treatment are dried and sold as fancy bones for button and novelty making. The button scrap, known as "dentelles," is bought back and returned to process where it left off. With cattle feet, after a short boiling or steaming, the hoofs are separated by a machine which squeezes the hoof and causes it to pop off the toe. With pigs' feet the hoofs are allowed to remain and are separated from the residue after boiling.

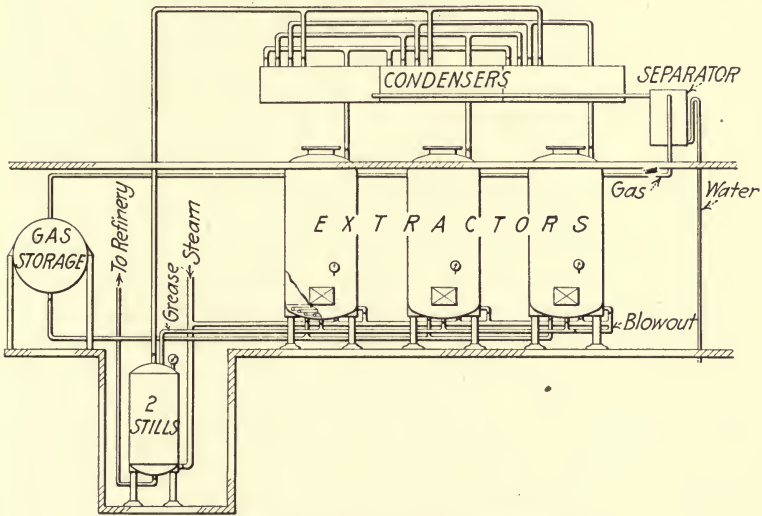

FIG. 53.—A three-extractor unit for degreasing bones.

Horns and hoofs have no value to the glue maker and are generally used by cutting to certain shapes, steaming and moulding in a press while hot, or they are ground and the pulverized horn made into a mixture which can be moulded like any other plastic. Often the less desirable hoofs and horns are ground and mixed into fertilizer.

To put the bone into the best possible condition for glue making, practically all the grease can be removed by solvent extraction. The solvent used may be benzine or gasoline, benzol, carbon tetrachloride, or carbon disulphide. This last has the disadvantage that it is extremely inflammable, has a noxious odor and is poisonous. Carbon tetrachloride is non-inflammable,



and the cost is the only objection. Benzine is perhaps the most commonly used. To obtain good extraction the bones must be dry—10 per cent moisture or less—otherwise extraction is hindered by the water and a certain amount of glue is extracted.

The accompanying sketch, Fig. 53, furnished through the courtesy of D. Obernethy of the Wilson-Martin Co. shows a three-extractor unit.

The crushed unscreened bones are filled into the extractors and solvent sufficient to cover the closed steam coils is run in from the storage tank. Steam is then admitted to the coils and extraction proceeds through the condensation of the solvent on the bone and percolation back to the main body of the liquor on the coils. After a short time the outlet valve at the top is slightly opened and the gas (or solvent) and water distilled into the condenser. The liquor from the condenser passes into a separator which allows the solvent to return to the storage tank and the water to pass from the lower outlet.

When the solvent has all been distilled a second supply of solvent is admitted and the valve closed, the process being repeated as before. After a second extraction and distillation the grease emulsion is drawn into the still. The whole operation is again repeated until the condenser liquor shows very little water, when extraction is assumed to be complete. After the grease emulsion is emptied into the still line, steam is blown through the extractor to the limit of the condenser to completely expel all solvent from the bone. This is continued until the condensate is all water, when all valves are closed and the top and bottom covers opened to admit of a good circulation of air for drying the bones while still hot.

While one extractor is being emptied and refilled, one of the stills is operated on the condenser which would otherwise be idle. When all water and gas are removed the grease is drawn to the refinery where it is washed with water and acid as described later.

Extraction may be conducted under either pressure or vacuum, the first having the advantage of ease of operation, the latter of low temperature and consequent minimum injury to the glue. The finished bone contains  $\frac{1}{10}$  per cent of grease or less as compared to about 1 per cent in bones degreased by cooking. Also the space required for storage has been decreased about 20 per cent, and the condition of the bones is such that they will



permit almost indefinite storage without deterioration, producing glue of better grade and color.

Green bone may be boiled with no preliminary treatment other than a thorough washing and a change or two of weak acid. If boiled in open boxes in the same manner as hide stock, the time of boiling is increased to four or more hours per run and the temperatures are higher, most of the runs being actually boiled.

If autoclaves or pressure tanks are used for boiling, the time is materially shortened because of the higher temperature obtained, the liquor is more easily clarified, and the bone residue is softer and more completely extracted. In some instances this addition of water and removal of liquor from the pressure tanks is made continuous, principally for the purpose of getting a liquor of higher concentration and a more complete extraction. It is claimed that the residue contains less than half the amount of nitrogen left in the residue from open boiling. Several patents have been taken out for the alternate application of pressure and vacuum in the autoclaves, for producing better penetration of the water and thus giving a more concentrated liquor.

The liquors from bones are treated similarly to hide glues throughout the remainder of the process, with the exception that, since they are of a lower test they are evaporated to a higher concentration before being chilled and cut.

If sulphurous acid is passed over bones they will absorb from 11 to 12 per cent of their weight of the gas, forming insoluble dicalcium phosphate and calcium sulphite. In this condition the bones are readily disintegrated by hot water and the gelatin rapidly extracted. This is the Grillo-Schroeder process.<sup>22</sup> The mud residue is oxidized or exposed to the air to convert the sulphite to sulphate and then used for fertilizer.

3. **Ossein.**—Bone, exclusive of the marrow, blood vessels, nerves and the like, consists of a cell substance and matrix. The cell substance is very resistant to both acids and alkalies and yields no gelatin on boiling with water. The organic portions of the matrix yield gelatin, and the problem of the manufacturer is to so prepare the bone that the hydrolysis to gelatin may be conducted with the least possible deterioration of the product.

Prolonged treatment with dilute acid seems to be the most efficient method of preparation, but at the same time it is the most troublesome and expensive. By such treatment almost all the inorganic substances are removed. The cell substance

is partly lost, the little which remains being the truly insoluble portion, and there is left only the periosteum and the organic portion of the matrix.

This *ossein* can be limed and handled in a manner similar to hide or sinew stock, and if the proper care is used throughout, the process yields a bright strong gelatin of the highest quality.

For the making of ossein, selected degreased stock only is used, hornpiths, dentelles, and jaw, knuckle, and rib bones being among the favorites.

The number of acids suitable for the production of ossein are rather limited. Although the calcium salts of several acids are soluble in water, the acid radicle has an injurious effect on the glue-forming material. Nitric and acetic acids are examples of this class. Hydrochloric acid is by far the most commonly used. The reactions are as follows:

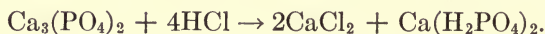

If the liquor is allowed to stand in contact with the bone indefinitely, the acid calcium phosphate reacts further as follows:  $\text{Ca}(\text{H}_2\text{PO}_4)_2 + \text{Ca}_3(\text{PO}_4)_2 \rightarrow 4\text{CaHPO}_4$  which is practically insoluble, leaving nothing but  $\text{CaCl}_2$  in solution. This can be regenerated by sulphuric acid:

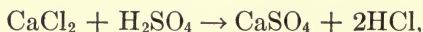

or if the liquor contains monocalcium phosphate:

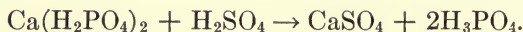

Both of these acids can then be used for a second leaching. As far as convenience is concerned hydrochloric acid is much to be preferred, for although 4 parts of acid dissolve 3 parts of lime in both cases:

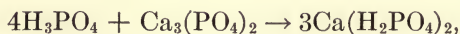

the weight of phosphoric acid required is almost three times as great, and the reaction is somewhat slower. On the other hand, commercial muriatic acid always contains iron, and iron is one of the principal sources of color in glue. If the acidity of the liquor is allowed to drop very low during any stage of the leaching process iron is deposited as ferric hydrate which it is almost

impossible to remove completely by increase in acidity. If sulphurous and phosphoric acids are used in the final stages of the leaching, the sulphurous acid reduces the iron to the ferrous state, which then forms ferrous phosphate which is colorless. Apparently the difficulty in removing this color is not altogether due to

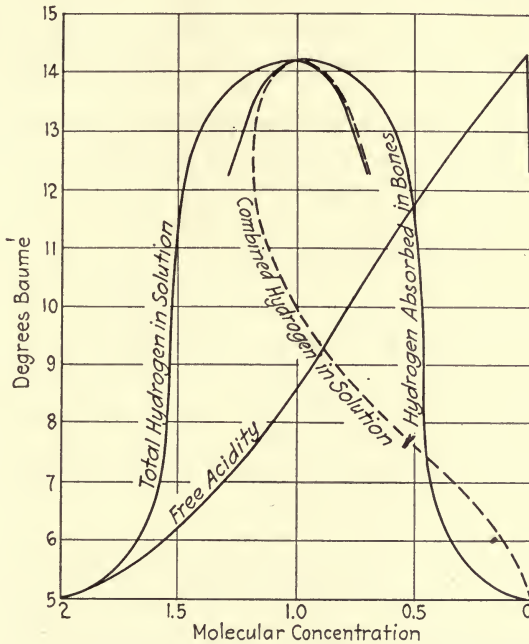

FIG. 54.—Acidity changes in ossein leach liquor.

the slight solubility of the iron salts, but to the formation of organic combinations or adsorption compounds which do not respond to the same treatment as pure iron salts.

The strength of the hydrochloric acid used generally varies from 2 to 5 per cent. The bones are placed in wooden vats and covered with the dilute acid. Great care is necessary that the stock is not injured by a rise in temperature. When the acid is exhausted it is drawn off and replaced by fresh acid. This is repeated, changing the concentration as required, until the bones are practically free from lime, when they are ready to be removed and washed and perhaps dried for storage. One pound of bone requires roughly one pound of 22° acid for complete extraction. Figure 54 is illustrative of the change in acidity of a leach liquor

used on bones perhaps two thirds exhausted. This is merely a graphical representation of the distribution and fate of the total ionizable hydrogen supplied in the 2 normal hydrochloric acid used for this change.

In the Bergmann process<sup>23</sup> sulphur dioxide is circulated through closed tanks containing the bones and continuously enriched with sulphur dioxide. The acidity is maintained high enough to retain the phosphate in solution. The sulphur dioxide is then recovered from the solution by treatment with steam in a lead lined digester and the calcium sulphite then decomposed by the addition of the required quantity of hydrochloric acid. The reactions may be represented as follows:

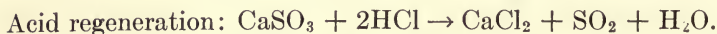
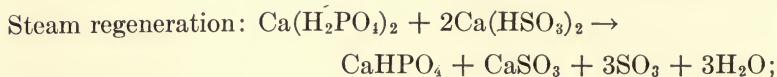
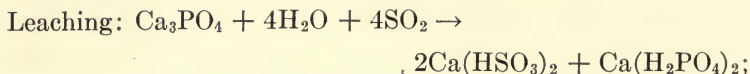

The precipitated dicalcium phosphate is washed free from the soluble chloride and dried for market.

**4. Gelatin.**—The making of gelatin differs from that of glue only in the selection of the raw material and the care and extreme cleanliness in operation. The raw materials for gelatin manufacture may be hide stock, green bone, or ossein. If hide stock, it is preferably that of young animals. Perhaps 50 per cent of the gelatin produced in this country is made from calf stock. If green bone is used, selected parts of the animal such as jaws, feet, and knuckles are chosen from the killing houses and worked up immediately so as to admit of no development of color and rancidity. Ossein must be firm and of good color.

In making a product for consumption as a food, especially when the material is as subject to bacterial decomposition as glue stock, eternal vigilance is the price of success. If the liming is very carefully watched, bacterial formation of sulphides can be prevented. The whole plant must be so constructed that the equipment may be kept immaculately clean without excessive labor. The use of wooden containers for liquors is inadvisable because of the difficulty in keeping them sterile. As the liquors generally are kept slightly acid, such metals as copper and zinc



offer danger of metallic contamination. Aluminum seems therefore to be the preeminently desirable constructional material. The acid and other secondary raw materials must be free from arsenic and other prohibitive impurities which may appear in the finished gelatin. Sulphites can be changed to sulphates by the use of hydrogen peroxide and removed in the clarification. To have the highest market value the color must be at a minimum and the product bright and sparkling both in the dry state and in solution.

However, from the standpoint of health, the objectionable substances which may be present are of little consequence compared to the possibility of excessive bacterial contamination. Occasionally objectionable stock has been used in making "edible" gelatin, or the method of handling has resulted in a partially decomposed or otherwise offensive product. It is not always a simple matter for such abuse to be detected in the laboratory, and the most effective means for preventing impositions of such a type from being continued seems to lie in a system of rigid inspection of all establishments purporting to manufacture an edible gelatin. Wilful violation of the public confidence should be regarded as a serious crime and dealt with accordingly.

### III. BY-PRODUCTS

The most important by product, in quantity at least, is the residue from boiling bones. When it is discharged from the boiling vat or pressure tank it is soft and easily crushed. This is spread on gunny bags steaming hot in layers of perhaps six inches in thickness, completely surrounded by the bag and stacked alternately with lattices made of wood into an hydraulic press. Here the last of the glue liquor and grease are pressed out and returned to process. The press-cake is broken up, and spread out to cool and dry, or dried in a rotary direct heat or steam dryer. This is then analyzed and mixed with other constituents to form a fertilizer of any desired analysis, ground and sacked for market.

Hair tankage, which is the residue left from the boiling of hide stock and fleshings, etc., contains a great deal of lime soap as well as hair and other organic matter. To recover the grease the tankage is boiled with dilute sulphuric acid and pressed the

same as the bone tannage. The remaining hair may be used as such or treated with hydrofluoric and sulphuric acids and converted to ammonium sulphate for fertilizer.

Grease is an important by-product. From the hock joint of cattle feet neatsfoot oil is obtained and on account of its value the hock joints are always boiled separately. Neatsfoot oil is considered the best basis of leather dressings on account of its property of working into moist leather and keeping it soft and pliable under all conditions of moisture and temperature. The clear oil from sweet fresh bones gives a tallow of good color and test. Bone tallows are always lower melting than the tallows obtained from the other parts of the animal.

The oil from pigs' feet has the lowest melting point of any of the glue works, oils and that from sheep stock naturally has the highest, as mutton tallow is very high melting.

Hide stock produces very little oil. Fleshings often produce a weight of grease equal to that of the glue. The part of this that comes off clear in the early boilings is of medium grade and has a good demand from the soap makers.

The grease from the later boilings contains quite a bit of lime soaps, as does also the press-grease from the hair tannage. This is most easily decomposed by boiling with acid, after which it is well washed with water and dried by heating. Unless the lime and glue are completely washed out, bacterial decomposition soon sets in, resulting in great loss of value. All grades of grease must be thoroughly washed with water and dried to assure good keeping qualities.

Mention was made in discussing green bones, of the necessity of keeping the stock sweet if rancidity of the fat is to be prevented. Although sulphurous acid, added immediately after washing, is the most common substance used for this purpose, many other bactericidal preservatives may be used if they fulfill the two requirements of having no injurious effect on the glue, and of preventing oxidation, for the development of rancidity is an oxidation phenomenon.

Although the acidity of the best of the fats is exceedingly low, there are many uses, especially for edible products, which require that the fat be neutral. A neutral fat is produced by alkaline refining. Briefly the operation consists of the addition of a calculated amount of caustic sufficient to a little more than satisfy the free fatty acid. This is conducted under carefully

controlled conditions of temperature and dilution so that a good curd of soap is produced. Sodium silicate is sometimes added to assist in the curd formation. The fat is then drawn off from the lower layer, washed and dried. This lower layer consists of soap, water, and some neutral fat, and can be acidulated to recover the fatty acid or used directly for soap making.

In the manufacture of ossein, the large volume of leach liquors containing acid calcium phosphate constitute a valuable by-product.<sup>24</sup> They are commonly precipitated with milk of lime to produce dicalcium phosphate,  $\text{CaHPO}_4$ , washed well with water to free from calcium chloride, if hydrochloric acid has been used in the leaching, then dried by steam or in a direct heat dryer and sold for fertilizer.

This so called "precipitated bone" contains 35 to 40 per cent total  $\text{P}_2\text{O}_5$ , most of it in the citrate soluble form. It is an attempt to make a pure  $\text{CaHPO}_4 \cdot 2\text{H}_2\text{O}$  which would analyze a little over 41 per cent  $\text{P}_2\text{O}_5$ .

The dicalcium phosphate, if carefully made, may be calcined to rid it of all organic and volatile constituents and used in the manufacture of phosphate baking powders. The almost total absence of fluorides and iron in bone phosphate makes it the only really desirable source of phosphate for this purpose.

The formation commercially of a calcium phosphate of definite composition is not a simple problem by any means. Being salts which easily hydrolyze they cannot even be washed with water and maintain a definite composition. As an illustration: If chemically pure dicalcium phosphate ( $\text{CaHPO}_4 \cdot 2\text{H}_2\text{O}$ ) be washed repeatedly with water which is allowed to stand until it has become saturated, analysis will show the wash waters to be relatively high in  $\text{P}_2\text{O}_5$  and the insoluble salt to have become correspondingly richer in  $\text{CaO}$ .

Also if chemically pure tricalcium phosphate is allowed to stand with water, samples from some sources may give alkaline liquors while others may give acid liquors. Atterton Seidell and others have made a study of these equilibria and the general facts of their observations are shown in Figs. 55 and 56. Starting at the left of Fig. 55: Mixtures  $\text{Ca}(\text{OH})_2$  and  $\text{Ca}_3\text{PO}_4$  give liquors of very rapidly decreasing  $\text{CaO}$  content until a minimum is reached at  $\text{CaO} = 0.01$  and  $\text{P}_2\text{O}_5 = 0.02$  gram per liter. From this point the solid phase is  $\text{Ca}_3\text{PO}_4$ , or more correctly, a solid solution of  $\text{CaO}$  in  $\text{CaHPO}_4 \cdot 2\text{H}_2\text{O}$ , and when  $\text{CaO}$

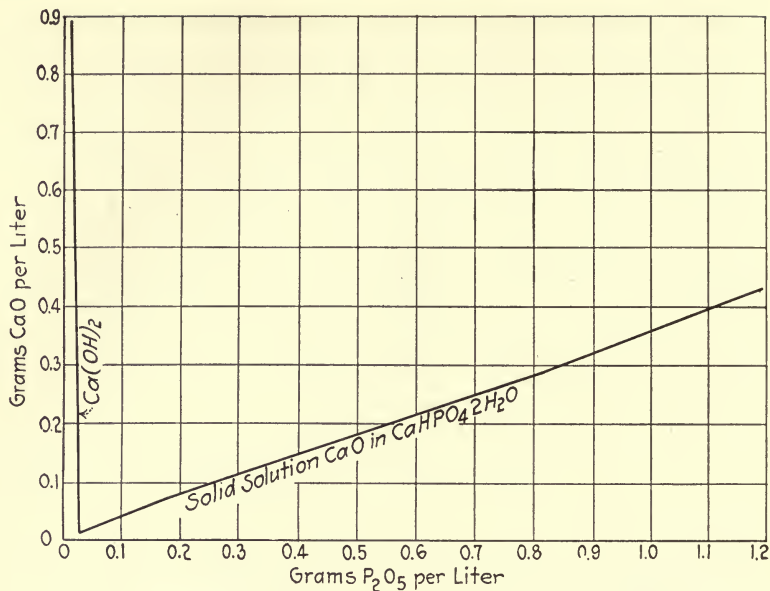

FIG. 55.—Composition of saturated solutions of calcium phosphate. I. (A. Seidell.)

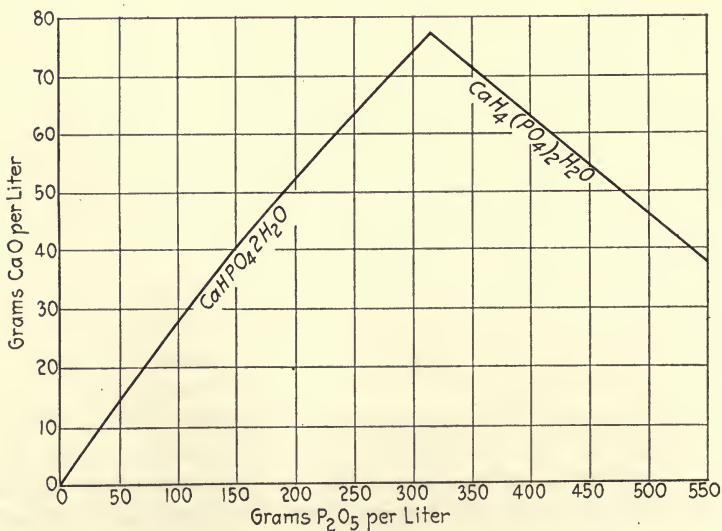

FIG. 56.—Composition of saturated solutions of calcium phosphate. II. (A. Seidell.)



= 0.03 and  $P_2O_5 = 0.07$  the solution changes from alkaline to acid. The general direction of the curve continues until somewhere in the region of  $CaO = 0.4$  and  $P_2O_5 = 1.1$  when the slight upward trend turns and becomes downward from the former general direction. This is probably the point of disappearance of  $CaHPO_4 \cdot 2H_2O$  and its replacement by  $CaHPO_4$  in the solid phase. Finally, at  $CaO = 77$  and  $P_2O_5 = 317$ , in Fig. 56, the small scale graph, the curve takes a new and sharply downward direction indicating the final solid phase of  $Ca(H_2PO_4)_2 \cdot H_2O$  which probably persists as long as any solid is present.

The precipitation of calcium phosphate of any definite analysis may be accomplished by addition of lime until the analysis of the liquor corresponds to that of the liquor in equilibrium with solid of the desired composition on the graph. This is desirable because a routine gravimetric analysis of the solid phase requires considerable time while a titration of the liquor may be obtained in about 10 minutes. Also if the calculated amount of lime is added and by accident the desired point is passed, the addition of liquor according to a new calculation for correction does not produce a precipitate as citrate-soluble as that resulting when no over-reaching has occurred.

The preferable procedure is to slowly add milk of lime while stirring thoroughly until 90 or 95 per cent of the desired amount is added, then to allow the mixture to stand over night to come to equilibrium. The following morning the liquor is analyzed and the amount of lime necessary for the completion of the reaction added as before. After standing again the results are checked up by a third analysis of the liquor, and if found correct, the liquor is drawn off and the precipitate washed and dried. Instead of using the titration method described in Chap. IX, conductivity determinations may be substituted but they take somewhat longer and variations in the amount of other soluble salts present introduce an unknown error.

If a distinctly acid phosphate is being produced, the phosphate remaining in the liquor drawn off may be precipitated by lime and the precipitate produced added to the liquor for the next batch without any washing or further treatment.

As before stated, washing increases the alkalinity of the precipitate and, therefore, only the minimum amount of wash water necessary to remove the undesirable soluble salts should be used.

The leach liquors may be converted into phosphoric acid according to the reaction:

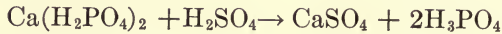

by the addition of sulphuric acid. If a high percentage of hydrochloric acid is present, it may be distilled off after concentration, or even distilled off before the addition of the sulphuric acid. It is difficult to find material satisfactory for holding solutions

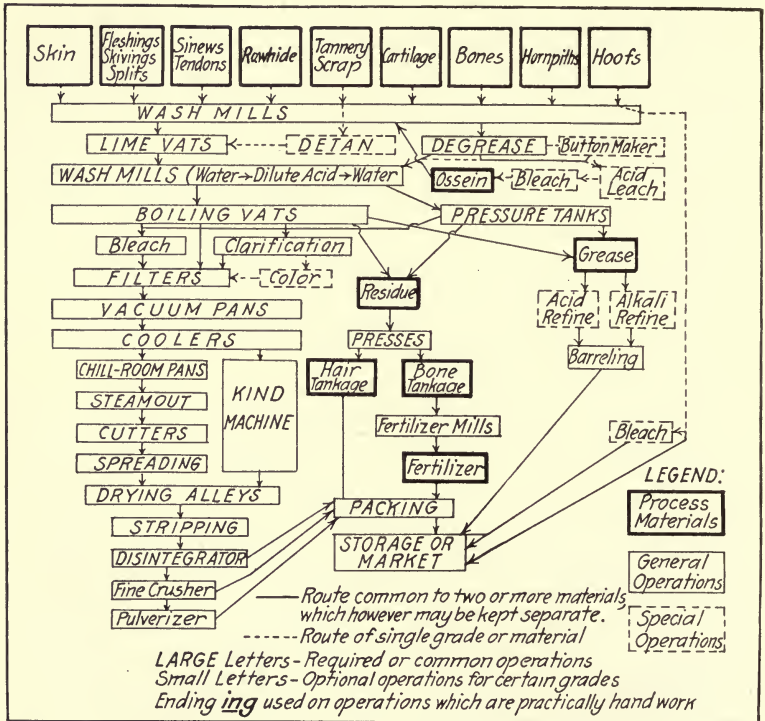

FIG. 57.—Course of glue stock through the plant.

containing a high percentage of phosphoric acid, especially if high temperatures are to be used. Phosphoric acid, especially in the presence of some of its salts, attacks silica very readily, and therefore has a marked action on glass. However, there is on the market at least one make of glass-lined steel tank which stands up very well at moderate temperatures, and at very high temperatures duriron may be used. The purification of phosphoric acid is a tedious process, consisting of precipitation of the

individual impurities, and is beyond the scope of this book to discuss.

It ought to be possible to produce phosphoric acid and any desired calcium phosphate from the leach liquors by electrolysis but there are a number of unsolved difficulties at present to be overcome. In the first place a tripartite cell would be required so that the liquor could be introduced into the central or neutral compartment and the acid and precipitate produced in their appropriate compartments. The diaphragm difficulties of the soda electrolysis are small as compared with the difficulties here. The disintegrating action of phosphoric acid is to be reckoned with in the acid diaphragm, and precipitation troubles have to be taken care of in the alkaline diaphragm. An investigation of this problem is recommended to any chemist who desires an extremely interesting subject for research.

An outline of the distribution and course of the glue stock throughout the entire manufacturing process is sketched in Fig. 57.

#### IV. A SELECT BIBLIOGRAPHY ON THE MANUFACTURE OF GLUE AND GELATIN

1. ABT, G., The rôle played by bacteria in the production of salt stains in hides and skins, *Collegium*, **5** (1913), 204; *Chem. Abstracts*, **7** (1913), 4093.
- ROEHM, O., Process of disinfecting hides and skins in the tanyard. *Ger. Pat.* 254,131 (1911), *J. Soc. Chem. Ind.*, **32** (1913), 483.
2. MOHLER, J. R., Disinfection regulations, *J. Am. Leather Chem. Assn.*, **13** (1918), 47; *Chem. Abstracts*, **12** (1918), 1133.
3. HAUSSNER, ALF., Theory of the beating engine, *Papier Fabrikant* (1913), 46.
4. CHING, W. C., Soaking in reference to dissolved hide substance, *Suppl. Rep. Tanners' Inst.* (1913), 20; *Chem. Abstracts*, **8** (1914), 1521.
- GRASSER, G., Chemical control of liming, *Technikum* (1912), 65; *Chem. Abstracts*, **7** (1913), 3854.
- MOORE, R. L., Change in composition of limes during the process of unhairing, *Suppl. Rep. Tanners' Inst.* (1913), 15; *Chem. Abstracts*, **8** (1914), 1521.
- PICKLES, J. E., Depilation of hides and skins, *J. Soc. Chem. Ind.*, **35** (1916), 456; *Chem. Abstracts*, **10** (1916), 1801.
- ROEHM, OTTO, A new unhairing process, *Collegium* (1913), 374.
- VENULETH and ELLENBERGER, Verarbeitung der leimwasser aus abdeckerein, *Swiss Pat.*, 58, 217 (1912); *Chem. Ztg.*, **37** (1913), 228.
5. BRACKET, A., Relation between the conductivity (and molecular weight) of acids and their absorption by hides, *Compt. rend.*, **155** (1912), 1614; *J. Soc. Chem. Ind.*, **32** (1913), 152.

FISCHEL, M., Treatment of shreads or cuttings of hides for the manufacture of gelatin, glue, and the like, *Eng. Pat.* 12,165 (1912); *J. Soc. Chem. Ind.*, **32** (1913), 229.

HILDEBRAND, J., Comparative valuation of deliming material, *Gerber*, **38**, 129; 143; *Chem. Abstracts*, **7** (1913), 1635.

PROCTER, H. R., The acid deliming process, *Tanners' Year Book* (1913), 75; *Chem. Abstracts*, **7** (1913), 4094.

6. ANON, The cost of hypochlorite disinfection, *Eng. Record*, **67**, No. 1-16; *J. Ind. Eng. Chem.*, **5** (1913), 255.

BOOTH, W. M., Water problems, *J. Ind. Eng. Chem.*, **2** (1910), 503.

DUTTON, M. S., Sterilization by liquid chlorine and hypochlorite of lime, *J. Am. Water Works Assn.*, **4** (1917), 228.

PHELPS, E. B., The chemical disinfection of water, *U. S. Public Health Repts.*, Reprint **225** (1914).

7. CORMACK, Glue extraction apparatus, *U. S. Pat.* 728,205 (1903).

8. THIELE, L., Apparatus for glue making, *U. S. Pat.* 989,826 (1911).

9. MANERHOFER, L., Autoclave tray for cooking glue, *U. S. Pat.* 1,337,146 (1919).

10. LEHMANN, J., Extraction of glue-containing substances, *U. S. Pat.* 964,980 (1910).

11. UPTON, G., Glue and gelatin manufacture, *U. S. Pat.* 1,063,229 (1913).

12. BANCROFT, W. D., The coagulation of albumin by electrolytes, *Trans. Am. Electrochem. Soc.*, **27** (1915), 195; *Chem. Abstracts*, **9** (1915), 1339.

HANCK, E., Clarifying glue, *Ger. Pat.* 234,859 (1909).

MICHAELIS, L. and DAVIDSON, H., The influence of H<sup>+</sup> concentration on mixtures of colloids, *Biochem. Z.*, **54** (1913), 323; *Chem. Abstracts*, **8** (1914), 3802.

MUTSCHELLER, A., Colloidal adsorption, *J. Am. Chem. Soc.*, **42** (1920), 2142.

NEIL, T. M., Glue manufacture, *Chem. Abstracts*, **6** (1912), 3208.

PROCTER, H. R., The action of dilute acids and salt solutions on gelatin. *Kolloidchem. Beihefte*, **2** (1910-11), 243; *J. Chem. Soc.*, **100** (1911), I, 342.

SCARPA, O., Reversible transformation of emulsoid solutions of gum Arabic and gelatin into suspensoid condition and the properties of such systems, *Kolloid-Z.*, **15** (1914), 8.

SNELL, J. F., The analysis of maple products, I. An electrical conductivity test for purity of maple syrup, *J. Ind. Eng. Chem.*, **5** (1913), 740.

TIEBACKX, F. W., The coagulum from gelatin-gum sols and its analogy with casein, *Z. Chem. Ind. Kolloide*, **8** (1911), 238.

TIEBACKX, F. W., Simultaneous coagulation of two colloids, *Z. Chem. Ind. Kolloide*, **8** (1911), 198.

WILSON, J. A. and W., Colloidal phenomena and the adsorption formula. *J. Am. Chem. Soc.*, **40** (1918), 886.

13. ALEXANDER, J., Colloid chemistry and some of its technical aspects, *J. Soc. Chem. Ind.*, **28** (1909), 280.

BANCROFT, W. D., Neutralization of adsorbed ions, *Trans. Am. Electrochem. Soc.*, **27** (1915), 175; *Chem. Abstracts*, **9** (1915), 1265.

14. BADISCHE, A. and S. F., Process of bleaching glue, *D. R. P.* 187,261 (1907).



DEVOS, A. D., Purification and decolorization of solutions of glue and sugar saps, *French Pat.* 446,549 (1912).

MEINFORD, R. W., Bleaching glue, etc., *Brit. Pat.* 134,011 (1918). *Chem. Abstracts*, **14** (1920), 806.

PICKERING, S. N., The color intensity of iron and copper compounds. *J. Chem. Soc.*, **105** (1914), 464; *Chem. Abstracts*, **8** (1914), 3737.

15. HUSBRAND, E., Verdampfen, kondensieren, und kühlen; erklärungent formeln und tabellen für den praktischen gebrauch, Ed. 5 (1912). Eng. Translation by A. C. Wright. Scott, Greenwood & Co., London, Ed. 2, (1903).

KERR, E. W., Tests upon transmission of heat in vacuum evaporators, *J. Am. Soc. Mech. Eng.*, **35** (1913), 1525; *Chem. Met. Eng.*, **11** (1913), 611.

MERRELL, L. C., et. al., Separating the moisture from the constituents of solids, or liquids, *U. S. Pat.* 860,929 (1907).

MOORE, H. K., Some general aspects of evaporation and drying, *Chem. Met. Eng.*, **18** (1913), 128; 186.

SADTLER, P. B., Vacuum evaporation, *J. Ind. Eng. Chem.*, **1** (1909), 644; *Chem. Abstracts*, **4** (1910), 648; Evaporators and Vacuum pans, *Chem. Met. Eng.*, **9** (1911), 206; 250; 305; 349.

16. ANDERSON, J. W., Vapor compression refrigerating machines, *Engineering*, **94**, 754; 792; 821.

ARROWOOD, M. W., Refrigeration; a practical treatise on the production of low temperatures as applied to the manufacture of ice and to the design and operation of cold storage plants, *Am. Sch. of Corresp.* (1913).

CAVALIER, P., Application of cold in glue and gelatin industries, *Chem. Ztg.*, **35** (1911), 17; *J. Soc. Chem. Ind.*, **30** (1911), 143.

GRINDLEY, J. H., A contribution to the theory of refrigerating machines, *Engineering*, **94**, 789; *Chem. Abstracts*, **7** (1913), 1083.

LUCKE, C. E., Mechanical refrigeration in manufacture, *J. Ind. Eng. Chem.*, **7** (1915), 462.

MACINTIRE, H. J., Chemical and mechanical applications of mechanical refrigeration, *Chem. Met. Eng.*, **7** (1914), 447.

MACINTIRE, H. J., Mechanical refrigeration (1914), Wiley.

*Nat. Elec. Light Assoc.*, To calculate the amount of refrigeration required, *Refrigeration World*, **46** (1913), 47.

SIEBEL, J. E., Compend of mechanical refrigeration and engineering. Ed. 8 (1911).

17. KIND, M., Glue making machines, *U. S. Pat.* 1,046,307 (1912).

LOWENSTEIN, A., Some machinery employed in the manufacture of glue, *J. Ind. Eng. Chem.*, **9** (1917), 710.

18. BAXTER, J. B. and STARKWEATHER, H. W., The efficiency of  $\text{CaCl}_2$ ,  $\text{NaOH}$ , and  $\text{KOH}$  as drying agents, *J. Am. Chem. Soc.*, **38** (1916), 2038.

BERT, E., Drying of air for blast furnaces, *Chem. Met. Eng.*, **10** (1912), 511.

BORN, S. and CARTHANS, W. F., Purification and sterilization of air, *J. Ind. Eng. Chem.*, **7** (1915), 233.

CAMMEN, L., Air drying for blast furnaces, *Proc. Eng. Soc. W. Pa.*, **33** (1917), 199; *Chem. Abstracts*, **11** (1917), 2655.

- CAMPBELL, C. H., Process of drying glue and gelatin, *U. S. Pat.* 1,047,165 (1912).
- CARRIER, W. H., The theory of atmospheric evaporation with special reference to compartment dryers, *J. Ind. Eng. Chem.*, **13** (1921), 432.
- CARRIER, W. H. and STACY, A. E., The compartment dryer, *J. Ind. Eng. Chem.* (1921), 438.
- DAUBINE, F. A. and ROY, E. V., Desiccation of air by calcium chloride, *Chem. Met. Eng.*, **9** (1911), 343.
- DUERLING, G., Method of manufacture of gelatin, *Eng. Pat.* 27,281 (1911).
- ERLWEIN, G., Apparatus for producing dry heated air by the action of moist air on sulphuric acid, *U. S. Pat.* 1,069,241 (1913).
- FLEMING, R. S., The spray process of drying, *J. Ind. Eng. Chem.*, **13** (1921), 447.
- FORRESTER, H. C., Apparatus for evaporating milk, blood, and other liquids to dryness, *Brit. Pat.* 23,436 (1911).
- GAYLEY, J., Refrigeration plant for dry air blast, *Iron Age*, **89** (1912), 52.
- GAYLEY, J., The story of the dry blast process, *Chem. Met. Eng.*, **11** (1913), 71.
- GROSVENOR, W. M., Calculations for dryer designs, *Trans. Am. Met. Chem. Eng.*, **1** (1908), 184; *Chem. Met. Eng.*, **8** (1910), 35.
- HART, J. H., The dehydration of air, *Cassiers*, **34** (1909), 122.
- KISTER, J. and FINSTERWALDER, C., Air filters, *Gesundh. Eng.*, **37** (1914), 757.
- LEWIS, W. K., The rate of drying of solid materials, *J. Ind. Eng. Chem.*, **13** (1921), 427.
- LEWIS, W. K., On the efficiency of air dryers, *J. Ind. Eng. Chem.*, **8** (1916), 570.
- MARLOW, T. G., *Drying machinery and practice*, London (1910).
- MARR, O., Drying processes used in the manufacture of glue and paint materials, *Farben-Ztg.*, **18**, 2806.
- MERRILL, I. S. and O. E., Desiccating milk or other liquid by spraying into a whirling current of air, *U. S. Pat.* 1,102,601 (1914).
- MORAWSKA, W., Cooling and purifying air, *Brit. Pat.* 8,053 (1912).
- OESTERLE, R., Refrigerating machines and the application of cold drying in gelatin and glue manufacture, *Farben-Ztg.*, **25** (1920), 2189.
- ROZENS, P., *Theorie et pratique du sechage industriel*, Paris (1909).
- TIDLEY, G. B., Tunnel dryers, *J. Ind. Eng. Chem.*, **13** (1921), 453.
- TIEMANN, H. D., The theory of drying and its application to the new humidity regulated and recirculating dry kiln, *U. S. Dept. Agr. Bull.* 509 (1917).
- RUGGLES, W. B., Dryers and drying, *Cassier's*, **35** (1909), 715.
19. TYNDALL, Experiments on absorption and radiation of moist air, showing that water vapor radiates readily, *Phil. Mag.*, **26** (1863), 30.
20. MERRELL, I. S., Desiccating apparatus, *U. S. Pats.* 954,451 (1910); 985,747 (1911); 1,082,468 (1913); 1,088,436 (1914).
21. BUNZEL, H., Pretreating bones for gelatin manufacture, *Ger. Pat.* 267,630 (1912); *Chem. Abstracts*, **8** (1914), 1034.

DORNER, L., Obtaining glue and fat from bones, *Ger. Pat.* 218,487 (1908).  
GIRSENWALD, C. V., Glue and gelatin manufacture with steam, *Brit. Pat.* 12,566 (1911); *Chem. Ztg.*, **36** (1912), 62.

LAMBERT, T., Bone products and manures, London (1901).

LOW, A. and FISCHER, E., Making glue, *U. S. Pat.* 1,086,149 (1914).

22. GRILLO and SCHROEDER, Ossein by the use of sulphur dioxide, *Brit. Pat.* 2175 (1894); *J. Soc. Chem. Ind.*, **13** (1894), 408.

23. COMBON, V., Manufacture of ossein by the sulphuric acid process, *Mat. grasses*, **4**, 2117; *Chem. Abstracts*, **5** (1911), 2757.

24. DUNHAM, H. V., Enriched superphosphates, *Brit. Pat.* 13,350 (1912); *Chem. Abstracts*, **7** (1913), 3811.

GANTLIER, A., The manufacture of calcium phosphate and the extraction of ossein, *Chemist*, **3**, 46; *Chem. Abstracts*, **6** (1912), 2809.

JENKINS, E. and STREET, J. P., Precipitated bones, *37th Rept. Conn. Agr. Exp. Sta.* (1913), 117.

KOCHETKOV, V. P., Preparation of the phosphate extracted by sulphurous acid from Viatka phosphate, *Chem. Abstracts*, **9** (1915), 2746; 2743.

## CHAPTER VII

### WATER-RESISTANT GLUES AND GLUES OF MARINE ORIGIN

The art of making glue consists in knowing what to do and how to do it.

Fernbach (1906).

	PAGE
I. Water-Resistant Glues.....	318
1. Casein Glue.....	319
The Manufacture of Casein.....	320
Government Specifications for Casein.....	325
Influence of Method of Manufacture upon the Use of Casein in Glue.....	325
Methods of Testing and Analysis of Casein.....	327
The Preparation of Casein Glue.....	333
The Application of Casein Glue.....	337
The Strength and Water Resistance of Casein Glue.....	339
Bibliography of United States Patents on Casein Adhesives...	340
2. Blood Albumin Glue.....	344
Preparation of the Glue.....	345
The Application of Blood Albumin Glue.....	345
Dry Glue Process for Thin Veneer.....	347
II. Glues of Marine Origin.....	349
1. Isinglass.....	350
The Manufacture of Isinglass.....	350
The Composition, Properties, and Uses of Isinglass.....	354
2. Liquid Fish Glue.....	356
Source of Raw Materials.....	357
Methods of Manufacture.....	358
Practical Tests to Determine the Quality of Fish Glue.....	359
Composition.....	361
Properties.....	364
Uses.....	365
A Select Bibliography on Fish Glues.....	365
III. Comparison of Various Glues.....	362

#### I. WATER-RESISTANT GLUES

Many attempts have been made to produce an insoluble and water-resistant glue from ordinary animal glue by the addition to it of some "hardening" reagent. Formaldehyde and potassium bichromate have been used for this purpose, but although



they do produce a product that is nearly insoluble, and that swells to a much smaller extent than the untreated glue, yet joints made by them fail to retain their strength when subjected to a drastic treatment with either cold or hot water. The glue in the joint is still capable of imbibing water from a humid atmosphere or from rain, for example, to a degree that makes it unsafe for general waterproof service. To be satisfactory as a water resistant material the glue must not only be insoluble but must also retain a fair degree of its original strength upon subjection to severe water treatment. A slight swelling of the glue in the joint is not permissible as a dangerous weakening inevitably results therefrom.

The only glues that have proved satisfactory for water resistant purposes, and that are strong enough for the best joint and veneer work, are the casein and blood albumin glues described below.

**1. Casein Glue.**—The employment of casein as an adhesive had, prior to 1918, been confined almost entirely to a few trades and districts in Europe where it had found a limited application in bookbinding and cabinet work, but large scale production was unknown. Casein had however been used in quantity in the sizing and coating of paper for many years prior to the war. The material was mostly imported from South America in the dry state as natural casein, and brought into a thin creamy solution before use by dissolving in a weak solution of ammonia, soda-ash, or borax. Reed furniture is often sized with casein glue to give it a light creamy, rather than amber, tone.

In July, 1918, a committee of technical men appointed by the United States Shipping Board seriously considered the possibilities of casein as a basis for waterproof glue for the first time. The need for such a product came primarily from the Bureau of Aircraft Production. Ordinary types of animal glue, or of other types that were in common service, as marine and vegetable glues, were sufficiently strong for all purposes under ordinary conditions of weather, but when exposed to water, or even to a highly humid atmosphere for some time they became weak due to the absorption of water, and the consequent swelling which they underwent. This objectionable feature of animal glues could be largely overcome by the application of a waterproof varnish or lacquer over the surface exposed, but such a practice seemed not to be practicable in all cases. Propeller blades were

treated in that manner with success, but the plywood entering into the construction of the craft could not be treated satisfactorily, and a weakening and separation of the layers of wood occurred.

The need for a waterproof glue therefore became very urgent. Representatives of the Army and Navy estimated an annual requirement of 3,000,000 pounds,<sup>1</sup> and there was at the time only one plant in the country manufacturing a casein glue. To augment the difficulty further it was known that different makes of casein were very dissimilar in their adaptability to glue manufacture. In short, a practically new industry was to be initiated for an immediate large scale production, and a uniformity of high grade product, previously unattained even in small scale production, had to be developed.

The Dairy Division of the Bureau of Animal Industry and the Forest Products Laboratory of the Department of Agriculture were assigned the problem, and the literature upon the subject is essentially confined to these two stations.

*The Manufacture of Casein.*—The only source of casein is milk. It occurs as the principal protein of the milk in the form of the calcium salt, and in this form is suspended as a colloid. Approximately 3 per cent of cow's milk is casein. Whenever any acid is introduced into the milk the calcium caseinate is decomposed in an entirely analogous manner to the metal gelatinates that have already been described<sup>2</sup> forming the ions of the inorganic calcium salt, and uncombined casein. This uncombined casein is insoluble, and separates from the remaining liquid as a curdy precipitate.

*Lactic Acid or Natural Sour Method.*<sup>3</sup>—In the natural souring of milk the *bacterium lactis acidi* attacks the lactose or milk sugar producing lactic acid, and this acid functions as above bringing about the coagulation of the casein. Whole milk is never used since the separation of the fat and its utilization for the manufacture of butter is a necessary economic part of the milk industry. Buttermilk is sometimes used but skim milk is best. The milk is allowed to stand at room temperature until the lactic acid fermentation has proceeded to the point where the curd begins to separate from the whey, and then is warmed to

<sup>1</sup> Cf. W. M. CLARK, *J. Ind. Eng. Chem.*, **12** (1920), 1162.

<sup>2</sup> Cf. Chapter V.

<sup>3</sup> S. BUTERMAN, *J. Ind. Eng. Chem.*, **12** (1920), 141.

130°F., when the separation becomes complete. After draining off the whey, the curd may or may not be washed with cold water. The curd is squeezed in cloth bags to remove as much of the liquid as possible and dried by spreading on trays in a drying alley through which air at a temperature of about 130°F. is circulating. It is then ground and is ready for use.

Fresh skim milk is sometimes soured rapidly by mixing a stream of it, as it falls into a tank, with a second stream of the whey that has been run off from a batch previously treated.

Dahlberg<sup>1</sup> has reported an "ejector" method developed by the Bureau of Animal Industry. The milk is allowed to sour until its acidity, expressed as lactic acid, and using phenolphthalein as an indicator, is 0.8 to 0.9 per cent. It is then allowed to run out of the tank through an ejector where it is heated rapidly by introducing steam, and falls into a second tank. The curd collects on the top and, after draining off the whey, is washed, pressed, and dried as above.

*Acid Coagulation Method.*—Much time may be saved by adding an acid directly to the milk rather than to allow the bacteria to produce the required acidity. The greater part of the casein manufactured in this country has been made by this process, although the grain-curd method described later offers such great advantages that it will probably soon be the leading procedure.

The fresh skim milk is heated with steam to a temperature of 120°F., and sulphuric acid added to the extent of one pint of acid (sp. gr. 1.84) mixed with a gallon of water to each 1,000 pounds of milk. The mixture is stirred until the curd separates, when the whey is drained off, and the curd washed, pressed, and dried.

Instead of finishing in the above manner, the curd is sometimes covered with water and brought to 170 or 175°F. This causes the curd to collect into a semi-fluid, plastic, tough mass. The water is drained off, and the soft curd barreled and shipped in that form. Hydrochloric acid is substituted for the sulphuric acid in some creameries where the whey is subsequently treated for the recovery of lactose, as the latter acid introduces mechanical difficulties in that separation.

*Rennet Coagulation Method.*—The casein of milk may also be coagulated by treatment with rennet. This method does not appear to be in favor among manufacturers, chiefly, perhaps, on

<sup>1</sup> A. O. DAHLBERG, U. S. Dept. Agr. Bull. 661.



account of the very high ash content of the resulting casein, and, as will be shown later, the ash content has much to do with the properties of the product in glue manufacture.

*The Grain-curd Method.*—When it became imperative to manufacture large amounts of casein of a high quality for waterproof glues the several methods in use were examined and none of these seemed properly adapted to the purpose. The natural-sour method was eliminated on account of its slow action. Sulphuric acid precipitation was undesirable because of the precipitation of calcium sulphate which interfered with the lactose separation. High temperature methods were rejected on account of other complications which it made difficult to control. Precipitation with hydrochloric acid remained, but this method had previously yielded very poor casein. Van Slyke and Baker<sup>1</sup> had improved this method but the product was very finely divided and could not be handled properly in large quantities. The hydrochloric acid precipitation method was accordingly studied by the Dairy Division of the Bureau of Animal Industry, and a new procedure, designated as the *grain-curd method* has been reported by Clark, Zoller, Dahlberg, and Weimar.<sup>2</sup>

The new method makes use of the fact that casein is an amphoteric electrolyte, having its isoelectric point at pH 4.6. At this hydrogen ion concentration the casein is not only more insoluble than at any other point, but it is also uncombined with any cation or anion in the solution. Thus, in milk, casein is in the form of calcium caseinate, and at any pH greater than about 4.6 some of the calcium must remain in combination with the casein, and no amount of washing could liberate it. The amount of the calcium so combined is proportional to the extent the pH diverges from 4.6, and at the latter value it is theoretically zero, so that by proper washing at that pH, practically all of the calcium may be eliminated, and a product of very low ash be obtained. The significance of this will be explained later.

The authors of the process found that methyl red could be used in plant practice with remarkable success for the control of the acidity of the milk. Methyl red does not indicate correctly in the presence of whey, but it was observed that an apparent pH of 4.6, which was by electrometric methods actually only 4.1,

<sup>1</sup> VAN SLYKE and BAKER, *J. Biol. Chem.*, **35** (1918), 127.

<sup>2</sup> W. M. CLARK, *et. al.*, *J. Ind. Eng. Chem.*, **12** (1920), 1163; H. F. ZOLLER, *ibid.*, **13** (1921), 510; Y. OKUDA and H. F. ZOLLER, *idem*, 515.



produced a casein curd of the particular resiliency and consistency most favorable for washing and handling.

If this curd were then washed, after draining off the acid, with water, especially if any alkaline salts were present, there would be a tendency to redispersion of the casein and loss of resiliency and porosity of the mass upon which efficient commercial washing depends. For this reason the wash water must also be acidified to the same pH as the casein, and hydrochloric acid is used for the purpose, methyl red again serving as the indicator.

Buffer solutions are recommended for the standard in comparisons, the phthalate-sodium hydroxide buffer solutions of Clark and Lubs<sup>1</sup> being most convenient. A color comparator<sup>2</sup> may be used if desired.

*Instructions for the Preparation of Technical Grain-curd Casein.*<sup>3</sup>—The skim milk should be as free from fat as possible and sweet as possible. It should be delivered to the casein precipitating vat at a temperature of 90°F. or, preferably, lower.

The hydrochloric (muriatic) acid used in the precipitation of the casein should be diluted with water in the ratio of 1 lb. of acid (20°Bé.) to 8 lbs. of water.

The wash water used in washing the casein should be made up as follows: To a tank of water add hydrochloric acid until an acidity of 4.8 is shown by use of the methyl red indicator solution. Stir the acid thoroughly into the water.

The indicator solution may be prepared by dissolving 0.4 gram of the pure crystals of methyl red in 1,000 c.c. of 95 per cent grain alcohol. This gives about 0.04 per cent solution.

The indicator standards should be prepared by measuring, with a 10 c.c. pipet, 10 c.c. of the standard solution mixtures marked "4.6-4.8," etc., into test tubes of uniform diameter, and adding to each 10 c.c. portion 5 drops of the methyl red indicator. Close each test tube with a clean cork stopper and seal with paraffin. If it is found necessary to use 10 drops of the indicator solution in the unknown solution in order to make easier readings, this may be done. In any case, the same number of drops should be used in the "unknown solution" as are used in the indicator standard.

*Procedure in the Precipitation of Casein.*—(1) Heat the skim milk, if reasonably fresh, to 94°F. If the milk is very sour, a temperature of 93°F. is more satisfactory. Under no circumstance should the temperature be above 96°F.

2. Add the diluted hydrochloric acid to the milk in fine spray and stir rapidly until the milk "breaks." Just before the milk breaks the acid should be added more slowly, but the stirring should be rapid. It is good economy

<sup>1</sup> Cf. *Appendix*, page 603.

<sup>2</sup> See *Appendix*, page 606.

<sup>3</sup> As issued to manufacturers by W. M. CLARK, *et. al.*, *loc. cit.*

to add no more acid *at this stage* than is required for the complete separation of the casein from the whey, but it is essential that the casein, after having had most of the whey drained away, should be acidified as in Paragraph 4.

3. Allow the curd to settle in the vat; pull it away from the gate valve and drain off through the drain cloth at least one half of the whey as indicated by a measuring stick.

4. Stir the curd thoroughly but not rapidly with the remaining whey in order to break up any lumps, so that the washing may be done more thoroughly. Now add more acid in small quantities, mixing it with the curd. Test 10 c.c. portions of the whey by means of the indicator solution until an apparent acidity of pH 4.8 to 4.6 is obtained. It is well to avoid breaking the curd into fine particles at this stage, so that the drain cloth will not become clogged. The curd should be firm but not slippery when the correct quantity of acid has been added. The temperature has a marked influence on the "feel" of the curd at this stage.

5. Now drain off the remainder of the whey through the drain cloth, retaining as much of the curd in the vat as practicable.

6. Pour a little wash water<sup>1</sup> over the casein which has run upon the drain cloth. Also wash the casein in the vat by completely covering it with wash water and mixing the curd carefully with it.

7. Now drain all the curd upon the drain cloth and wash again by pouring a liberal quantity of wash water over it. Allow the casein to drain as well as practicable before placing it in the press.

8. Dump the casein and fill it into the casein press in thin layers so that the pressed cake is about 2.5 inches in thickness. At first very little pressure should be brought to bear upon the casein in the press. The pressure may be increased slowly as the liquid drains from the cake. Uniform pressure should be maintained over the entire cake.

9. The pressed casein should now be ground through a curd mill and spread in layers about 0.25 inch thick on trays in the drying tunnel.

10. The temperature of the drying tunnel should be about 125°F., using a strong blast of air.

The above directions must be modified slightly, however, if the milk used has previously been pasteurized. Zoller<sup>2</sup> has shown that the curd precipitated by the above method from milk that has been heated is soggy and not easily handled. He finds, however, that by raising the temperature of precipitation from 94 to about 112°F. good results may be obtained. The longer the time period of the original pasteurization, and the higher the temperature of the pasteurization, the higher also must be the temperature of precipitation in order to obtain a firm and workable curd.

<sup>1</sup> It must be remembered that this wash water is the very dilute hydrochloric acid solution described above.

<sup>2</sup> H. F. ZOLLER, *J. Ind. Eng. Chem.*, **13** (1921), 510.

*Government Specifications for Casein.*—The government specifications<sup>1</sup> require that all casein used for making water-resistant glue for use in airplanes should pass the following tests:

Color: White or light cream.

Odor: Nearly odorless, with not more than a trace of sourness.

Moisture: Not more than 10.0 per cent.

Fat: Not more than 1.0 per cent.

Ash: Not more than 4.0 per cent.

Nitrogen: Not less than 14.25 per cent.

Acidity: Not more than 10.5 c.c. N/10 alkali per gram.

*Influence of Method of Manufacture upon the Use of Casein in Glue.*—The caseins that are commercially available range in quality from almost pure white, sweet material, low in ash and other impurities, to a dark brown substance, which may be very sour and give off an offensive odor. A peculiar anomaly among manufacturers of casein glue lies in the preferences that some have to a casein made, for example, by the natural-sour process, while others can obtain satisfactory results only by the use of a product that has been precipitated by mineral acids.

A chemical examination of the caseins produced by the several methods of manufacture show (1) fairly uniform results for a product made in any given way, but (2) widely different results between products made by different methods. The following table illustrates this. The analysis under each method is entirely representative of that particular procedure.

TABLE 44.—ANALYSES OF CASEIN MADE BY DIFFERENT METHODS<sup>2</sup>

Method	Moisture, per cent	Fat (mois- ture-free basis), per cent	Ash (mois- ture-free basis), per cent	Nitrogen (moisture- fat- ash-free basis), per cent	Acidity, c.c.
Buttermilk .....	6.97	9.56	1.36	14.77	9.2
Grain-curd .....	9.48	0.33	1.65	14.84	9.9
Natural sour.....	7.87	0.27	2.16	14.84	8.7
Sulphuric acid.....	7.81	0.35	4.05	14.46	7.6
Sulphuric acid cooked.....	8.89	0.12	4.25	15.04	5.9
Hydrochloric acid cooked.....	9.44	0.18	4.71	15.03	5.2
Hydrochloric acid.....	7.10	0.16	5.74	14.32	6.7
Rennet .....	8.29	0.63	7.79	14.41	7.9

Acidity is expressed as c.c. of N/10 sodium hydroxide solution required to dissolve 1 gram of moisture- fat- and ash-free casein and give a solution neutral to phenolphthalein.

<sup>1</sup> U. S. Department of the Navy, Bureau of Construction and Repair, *Aeronautical Specification*, 85, Jan. 15, 1919.

<sup>2</sup> S. BUTTERMAN, *J. Ind. Eng. Chem.*, 12 (1920), 141.

One of the most apparent differences observed between caseins manufactured by the three commercial methods—lactic acid, mineral acid, and rennet—was in the different amounts of water required to produce glues prepared from them of the same viscosity. Butterman<sup>1</sup> concludes that “in general, caseins of the same type require a quantity of water which varies within a definite range and is somewhat sharply differentiated from the quantity required by other types. Indeed, in most cases (except in caseins made by the method of Sammis or by the grain-curd method) it is possible to name the method of manufacture by a mere observation of the relative amount of water required by the casein under investigation.” By an exhaustive comparison Butterman established the reason for this. He found that the higher the ash content of a casein, the greater the dilution at which it must be mixed to give a standard viscosity, and also the shorter will be the “life” of the product. By “life” is meant the period of time between the preparation of the glue and the point where it becomes too thick to spread properly. These points are illustrated in the following table of average values:

TABLE 45.—EFFECT OF ASH CONTENT ON PROPERTIES OF CASEIN GLUE

Type of casein	Ash, per cent	Water-casein ratio	Life, hours
Grain-curd.....	1.8	2.3	12
Lactic acid..... <i>Not Suer</i>	2.5	2.4	10
Mineral acid.....	4.0	2.8	7
Rennet.....	8.6	3.9	5

By plotting the ash content against the water-casein ratio Butterman obtained a curve from which he derived an equation of the general type:

$$y = mx + c.$$

Hence if  $A$  is the ash content of the casein, and  $W$  the water-casein ratio required to give a glue of medium viscosity, the glue formula 4-A gives the equation:<sup>2</sup>

<sup>1</sup> S. BUTTERMAN, *loc. cit.*

<sup>2</sup> *Vide* page 335. The equation would vary slightly with any variation in the formula used.



$$W = 0.24A + 1.85.$$

It is therefore possible, by making a determination of the ash content of any casein, and applying the results to the equation, to tell at once the proper proportion of the ingredients required to mix it into a satisfactory glue, regardless of the method by which the casein has been made, and by that means to be certain of uniform results.

The control of the ash content of the casein lies in two factors: the hydrogen ion concentration to which the milk is brought during the precipitation, as already described, and the washing which the curd receives. If the proper pH is maintained, the ash content decreases directly as the amount of washing it receives. It is easily possible, in the grain-curd process, to bring the ash down to about 1.7 per cent by only two washings, and in plant practice it should not rise above 2.5 per cent.

Clark<sup>1</sup> has shown further that all caseins change weight very rapidly by absorption or loss of water when subjected to atmospheres only slightly different from the normal. In cool dry air they lose weight rapidly, while in warm moist air they quickly increase in weight. At humidities between 85 and 95 per cent the absorption of moisture is so rapid as to become "dangerous." The grain-curd caseins are however shown to be superior to any of the other types in that they respond more slowly to changes in atmospheric conditions, and tend to retain a smaller quantity of moisture. Casein that has been subjected to a high temperature treatment is most sensitive to increases in humidity, and also tends to retain the moisture more firmly than the other types. The ash content is not held responsible for these changes in water-absorptive capacity, but rather the effect of heat upon the casein molecule.

*Methods of Testing and Analysis of Casein.*—A few scattered tests upon casein have been suggested by earlier workers, but these are for the most part of doubtful significance. A "borax solubility test"<sup>2</sup> was one of the earliest of these, and an "adhesive" test<sup>3</sup> has been employed. Reuter<sup>4</sup> examined casein by testing for iron, acidity, metals, sulphates, and chlorides, in

<sup>1</sup> W. M. CLARK, *et. al.*, *loc. cit.*

<sup>2</sup> A. DAHLBERG, U. S. Dept. Agr. Bull. 661.

<sup>3</sup> A. DAHLBERG, *idem.*

<sup>4</sup> REUTER, *Papier-Ztg.* (2), 32 (1907), 3374.

addition to using the borax solubility test. Hopfner and Burmeister<sup>1</sup> and also Burr<sup>2</sup> have suggested the determination of moisture, fat, ash, nitrogen, and free acidity.

These determinations were adopted with several modifications by the Forest Products Laboratory<sup>3</sup> and used as the official methods of examination by the Office of Aircraft Production in their specifications for casein to be used in making glue. A careful study of these methods was made later by the Dairy Division of the Bureau of Animal Industry,<sup>4</sup> and it was found that, in some instances, wide discrepancies arose among the results of different analysts, and that a further alteration in the methods was indicated.

In the following description of methods the official procedure will be given in all cases, followed by the modifications suggested by the Dairy Division.<sup>5</sup>

*Sampling for Analysis.*—If the sample is gathered from bins at the creamery, portions should be taken systematically from all parts of the bin. These should be ground together, if that has not been done previously. After the powder has been thoroughly mixed, the final sample is taken out to be sent to the laboratory. A 100 gram sample will be found to be sufficient for the determinations described. The sample received at the laboratory should be thoroughly mixed, 50 grams set aside for the determination of fineness, and the remainder reduced to 60 mesh size.

*Color.*—If possible the color of the casein should be observed at the creamery as it is taken from the driers. Grinding makes the casein appear much lighter in color. Commercial casein may be obtained which is almost pure white, and the color need never be more than a pale yellow or cream.

*Odor.*—About 10 grams of the casein are soaked in about 10 c.c. of water and an equal volume of a rather thick "milk of lime" added with stirring. After the mixture has stood a few moments the odor is noted. Commercial casein may be obtained which is entirely free from odor, or, at most, has an odor resembling that of sweet milk. The rancid odor frequently associated with casein is not due to the casein, but to impurities or decomposition products of casein.

*Fineness.*—A 50 gram sample is placed in a 60 mesh sieve, the sieve is held in one hand and moved horizontally back and forth at the rate of about 120 strokes per minute, being allowed to strike at the end of each stroke against

<sup>1</sup> HOPFNER and BURMEISTER, *Chem. Ztg.*, **36** (1912), 1053.

<sup>2</sup> BURR, *Milch Zentr.*, **6** (1910), 385.

<sup>3</sup> F. L. BROWNE, *J. Ind. Eng. Chem.*, **11** (1919), 1019.

<sup>4</sup> R. H. SHAW, *ibid.*, **12** (1920), 1168.

<sup>5</sup> The official methods are quoted from F. L. BROWN, *loc. cit.*, and the modifications of the Dairy Division taken from the papers by R. H. SHAW, *loc. cit.*, W. M. CLARK, *J. Ind. Eng. Chem.*, **12** (1920), 1170, and H. F. ZOLLER, *idem.*, 1171.

the palm of the other hand which is held stationary. The portion passing through in 10 minutes is weighed, and reported as per cent passing 60 mesh.

*Moisture.*—This is most accurately determined by weighing out a 3 gram sample in a glass-stoppered weighing bottle, heating to constant weight in a vacuum oven at 70 to 80°C., cooling in a desiccator, and weighing. For most purposes it is more convenient and sufficiently accurate to use a porcelain evaporating dish and make the determination by heating in a Freas oven at 98°C., and atmospheric pressure for 5 hours.

Shaw has pointed out that five different analysts reported moisture determinations of identical samples of casein which differed from 7.55 to 9.01 per cent, or a difference of 1.46 per cent between the highest and lowest figures. In following up the reason for such a discrepancy they submitted 79 samples to the Bureau of Chemistry, and determinations for moisture were made by both the open dish—at atmospheric pressure and 98°C.,—method, and by the partial vacuum method. The average percentage of moisture by the former method was 7.44 while by the latter method it was 8.21, showing a difference of 0.77 per cent in favor of the latter method.

*Fat.*—The residue from the moisture determination is transferred to an extraction thimble and extracted for 16 hours with anhydrous redistilled ethyl ether in a Cauldwell or Soxhlet apparatus. The ether is evaporated from the extract, and the residue, corrected for the moisture content of the casein, is called fat. It is important that the sample for the fat extraction be finely ground.

Shaw reports that a modification of the Roese-Gotlieb method was applied to casein with very good results. He gives the following procedure:

Weigh out a 1 gram charge of the casein into the Roehrig tube, and add 10 c.c. of water. Shake vigorously, but not so as to carry particles of casein near the top of the tube. Let soak for at least 15 minutes; a longer time is advisable if the sample is not finely ground. Add 2 c.c. of strong ammonia water, and shake vigorously, again taking care not to carry particles of casein near the top of the tube. Let stand 10 minutes with occasional shaking. Add 10 c.c. of 95 per cent alcohol and shake until the casein is completely dissolved. From this point procede as usual with the Roese-Gotlieb method.

The Roese-Gotlieb procedure is as follows:<sup>1</sup>

Add 25 c.c. of washed ether and shake vigorously for 30 seconds, then 25 c.c. of petroleum ether (redistilled slowly at a temperature below 60°C.)

<sup>1</sup> Assoc. Official Agr. Chemists, "Methods of Analysis" (1920), 227.



and shake again for 30 seconds. Let stand 20 minutes, or until the upper liquid is practically clear. Draw off as much as possible of the ether-fat solution (usually 0.5 to 0.8 c.c. will be left) into a weighed flask through a small quick-acting filter. The flask should always be weighed with a similar one as a counterpoise. Re-extract the liquid remaining in the tube, this time with only 15 c.c. of ether, shake vigorously 30 seconds with each and allow to settle. Draw off the clear solution through the small filter into the same flask as before and wash the tip of spigot, the funnel and the filter with a few c.c. of a mixture of the two ethers in equal parts free from suspended water. For absolutely exact results the re-extraction must be repeated. The third extraction yields usually not more than about 1 mg. of fat if the previous ether-fat solutions have been drawn off closely. Evaporate the ethers slowly on a steam bath, then dry the fat in a boiling water oven to constant weight.

Confirm the purity of the fat by dissolving in a little petroleum ether. Should a residue remain, remove the fat completely with petroleum ether, dry the residue, weigh and deduct the weight. Finally correct this weight by a blank determination on the reagents used.

The Roesse-Gotlieb method yields results that are considerably higher than those obtained by the ordinary extraction procedure. Shaw believes that this is due to an incomplete extraction in the latter case, and that the results obtained by the former method are the more nearly correct and reliable. This may be due to the fact that the grains of casein are hard and not easily penetrated by the solvent, while by the Roesse-Gotlieb method the casein is in solution and it is impossible for any fat to remain out of contact with the solvent.

*Ash.*—A 3 gram sample is weighed out in a vitreosil dish and carefully charred over a low flame of a Bunsen burner. When completely carbonized, it is placed in an electric muffle furnace and heated at a dull red heat (not over 600°C.) until the ash is white, or at least light gray, and the weight is constant. A small amount of ammonium nitrate may be added to facilitate the combustion of the last traces of carbon. Care should be taken to avoid fusion of the ash if possible. Results are reported on a moisture-free basis.

The presence of phosphorus, sulphur, and alkali chlorides in the ash make the determination uncertain unless especial precautions are observed. If a temperature in excess of a dull red heat is used there is danger of volatilization of alkali chlorides, and if the casein is low in lime, so that there is not enough present to combine with all of the organic phosphorus and sulphur, these latter will also be volatilized. This difficulty may be overcome by mixing with the casein, before charring, a calcium salt.<sup>1</sup> Five

<sup>1</sup> U. S. Bureau of Chemistry, *Bull.* 107 (1908), 21.



cubic centimeters of a solution of calcium acetate yielding about 0.1 gram of CaO upon ignition may be added to the 3 gram sample of casein, allowed to stand until the solution is absorbed, then dried in a drying oven, carefully charred over a small flame, and finally ignited in an electric muffle furnace at a low redness. The weight of CaO added is subtracted and the results reported as before. This procedure is quite necessary in the case of low ash caseins, but if the ash is medium or high it is not required.

*Nitrogen.*—A one half gram sample is weighed out into an 800 c.c. Kjeldahl flask, 20 c.c. of concentrated sulphuric acid, 10 grams of crystallized sodium sulphate, and a small crystal of copper sulphate are added, and the contents digested until a clear solution is obtained, and then for 30 minutes longer. 300 c.c. of distilled water, 50 c.c. of a 1:1 solution of sodium hydroxide, and about one fourth gram of granulated zinc are added. About 250 c.c. are then distilled over and caught in standard sulphuric or hydrochloric acid. (30 c.c. of N/5 acid will be sufficient.) The excess acid is back-titrated with standard sodium hydroxide, methyl red being used as indicator. Since the nitrogen determination is made as a measure of the impurities other than moisture, fat or ash, results are reported on a moisture-, fat-, and ash-free basis.<sup>1</sup>

*Acidity.*—A one gram sample is placed in a flask and 25 c.c. of N/10 sodium hydroxide solution run in from a pipet. During this addition the flask is gently agitated. The flask is then stoppered and the agitation continued until the solution is complete. This should require only 5 or 10 minutes. The stopper is then removed and the portion of solution wetting it washed into the flask with a stream of water from a wash-bottle. 100 c.c. of distilled water (neutral to phenolphthalein) are added, and the solution back-titrated at once with N/10 acid, using 0.5 c.c. of alcoholic phenolphthalein solution (1 gram per 100 c.c.) as indicator. The acid is run in fairly rapidly with vigorous shaking of the flask so as to prevent precipitation of the casein locally. The number of cubic centimeters of N/10 alkali used up by 1 gram of moisture-, fat-, and ash-free casein is called the "acidity" of the sample.

Browne adds that if concordant results are to be obtained by this method the following precautions must be observed: "(1) The flask should be kept stoppered except when making additions or titrating; (2) the amount of indicator specified must be used and it must be adjusted with alkali so that one drop added to distilled water does not change its reactions; (3) local coagulation of casein during titration must be avoided; (4) the total

<sup>1</sup> The nitrogen content of pure casein is 15.67 (Richmond, "Dairy Chemistry"), so the conversion factor of nitrogen to casein becomes  $100/15.67 = 6.38$ .

time during which the casein is allowed to stand in contact with alkali must not exceed 30 minutes at room temperature."

Clark points out that this procedure is quite inadequate. It consists only in "titrating to an arbitrary pH, as indicated by phenolphthalein, a mixture of amphoteric protein, occluded salts, and the products of alkali hydrolysis of the protein." It was therefore only to be expected that the method should give no consistent results, "partly because of the difficulty of titrating to an arbitrary and insignificant pH, and partly because of the hydrolysis of the casein." By making use of the hydrogen electrode, and extrapolating back to zero time of contact between alkali and casein more satisfactory results were obtained.

*The Borax Solubility Test.*—This test has been reported as follows:<sup>1</sup>

To 50 grams of casein (ground to pass a 20 mesh sieve) are added 300 c.c. of water containing 7.5 grams of borax. This mixture is stirred thoroughly and is immediately set in a water bath controlled at a temperature of 6.5°C. With continuous stirring the casein should be completely dissolved in 10 minutes.

A special study of this test made by Zoller brings out several points of importance. The chief value of the test seems to be to determine whether the casein under examination exhibits suitable working properties, when dissolved by certain alkalies. Chick and Martin<sup>2</sup> showed that the viscosity of casein in sodium hydroxide increased rapidly after the concentration of the casein had reached 10 per cent. Zoller found the same to be true of casein dissolved in borax solution. For differentiating between the properties of several caseins a concentration of about 15 per cent was found most suitable.

The viscosity<sup>3</sup> of a solution of casein dissolved in borax was found to rise enormously (from 10 to 110 angular degrees as measured by the MacMichael viscosimeter) upon increasing the pH of the solution from the isoelectric point (pH 4.6) to pH 8.15, but upon further increases the viscosity again dropped rapidly until at pH 9.0 it had become practically constant. (About 21 angular degrees.) In making the test it is obvious that a pH should be attained such that the viscosity would fall upon the constant part of the curve. When dissolved in other alkalies the

<sup>1</sup> U. S. Dept. Agr. *Bull.* 661 (1918).

<sup>2</sup> CHICK and MARTIN, *Kolloid-Z.*, **11** (1902), 102.

<sup>3</sup> Cf. also H. F. ZOLLER, *J. Gen. Physiol.*, **3** (1921), 635.

maximum viscosity is reached at a pH of 9.1 to 9.25. It is highest in ammonium hydroxide.

High temperatures were found to alter seriously the physical properties of the casein, and a temperature of 30°C. was fixed as the most practicable.

The revised method as given by Zoller follows:

The casein is ground to pass a 40 mesh sieve; 15 grams of the casein are measured into a 250 c.c. beaker; 100 c.c. of 0.2 M borax at 30°C. (76.32 grams of  $\text{Na}_2\text{B}_4\text{O}_7 \cdot 10 \text{H}_2\text{O}$  diluted to 1 liter) are added with vigorous stirring. This is allowed to stand for 30 minutes, with thorough stirring at intervals of 5 minutes. During the first 5 minutes the mixture should be stirred rather frequently. A casein of known purity and conduct, should be used as control until thorough familiarity with the method is gained. Usually the character of the casein shows up during the first 10 minutes, but 30 minutes is advised for safety. Longer periods are unsatisfactory because of difficulty in interpretation.

The principal advantage of the test seems to lie in the rigid differentiation which it permits between high and low temperature caseins, the former, without fail, tending to imbibe water and form a jelly in the test, while the latter are still smooth clear solutions at the end of a half hour. If much fat is present the mix will tend to be somewhat gelatinous during the first 10 minutes, but after a half hour, with frequent stirring, will, unless it has also been heated, become redispersed into a milky and uncohesive liquid.

*The Preparation of Casein Glue.*—Casein is insoluble in pure water, but in the presence of any alkali will pass readily into a colloidal solution. Lime is most commonly used for this purpose in the preparation of casein glue. Casein, water and lime will produce a glue that has good water-resistant properties, but it sets rather rapidly into a thick paste which cannot be easily worked. It is therefore said to have a short life. Several other ingredients have been proposed to be added to the mixture to increase the life and otherwise improve the properties of the glue. Formulas have been patented involving the addition of sodium silicate, sodium hydroxide, and sodium fluoride. Oils are sometimes added to prevent dusting.

Casein glues may be designated as the dry-mix and the wet-mix types. The dry-mix glues are prepared by the glue manufacturer from formulas which are not made public, and shipped in dry form. These are prepared for use according to specific



directions which come with each formula glue. The National Advisory Committee for Aeronautics<sup>1</sup> defines the principal points to be observed in the mixing of prepared casein glues as follows:

1. A thorough mixing of the dry glue from each or all containers before adding to the water. This is advisable on account of the segregation of ingredients of different specific gravities which may occur during shipment from the factory to the consuming plant. Sifting is not advisable, as it may remove from the glue some essential component.

2. Proportions of glue and water should always be weighed, not measured.

3. The glue should be added slowly to the water accompanied by vigorous agitation in order to avoid a lumpy mixture.

4. After the glue is well mixed into the water, the stirring should continue more slowly until all particles are thoroughly dissolved and the glue appears of a smooth creamy consistency.

5. The desired consistency of the glue should be obtained during the mixing and no attempt should be made to thin the glue should it become too thick in use. It should be mixed only as fast as it is being used.

The proportions of dry glue and water should, in general, be as directed by the manufacturer. However, the exact proportions will vary with (1) different glues, (2) different shipments of the same glue, and (3) the kind of work for which the glue is to be used. Only average proportions can be stipulated by the manufacturer; and the operator, in order to obtain satisfactory consistencies, may find it necessary at times to vary from the average proportions specified.

The wet-mix glues are made up by the consumer from the raw casein, lime, and other ingredients.

Prior to the war there had been a number of casein cements suggested which were being employed to a limited extent as water-resistant glue. Typical of these may be mentioned the following:

One part of gum arabic is dissolved in 5 parts of 40 per cent water-glass and evaporated on the water-bath until sufficiently dry to grind. It is then ground to 50 mesh, and mixed with 150 mesh calcium hydroxide and 40 mesh casein in the proportions:

Gum-silicate mixture.....	20 parts
Casein.....	40 parts
Calcium hydroxide.....	25 parts

This mixture is then made up with water in the proportions of 45 parts dry mixture to 100 parts of water.

Another typical formula is as follows:

Casein.....	47.0 parts
Calcium hydroxide.....	29.5 parts
Sodium silicate.....	15.5 parts
Gum arabic.....	8.0 parts

<sup>1</sup> National Advisory Committee for Aeronautics, *Report* 66 (1920), 13.



A formula developed at the Forest Products Laboratory<sup>1</sup> using sodium silicate has proved especially satisfactory. It is specified as follows:

Formula—Glue No. 4-A.

100 parts casein	}	soak 15 minutes	}	mix	}	mix
130 to 280 parts water						
15 to 22 parts hydrated powdered lime	}	mix	}	mix	}	mix
90 parts water						
70 parts silicate of soda.						

This formula is prepared as follows:

The proper quantity of water is introduced into the glue pot, and the mixing blade is brought into action at a speed corresponding to about 50 or 60 revolutions per minute. The stirring is allowed to continue during the addition of the casein to the water and for a few minutes thereafter until the mixture becomes mush-like in consistency through the absorption of the free water by the casein. The blade is then stopped and the mixture allowed to soak.

After a period of 15 minutes the soaking is considered complete and the mixing blade is again brought into action. The lime water mixture is now added and two or three minutes later the silicate of soda is introduced.

The mixing is allowed to continue for from 20 minutes to  $\frac{1}{2}$  hour after the addition of the silicate of soda, whereupon a smooth, freely flowing mixture, of uniform texture and free from lumps, should be produced.

No precise quantity of water can be prescribed because of the variation of the water-absorbing qualities of different caseins. The criterion of whether or not the proper quantity of soaking water has been added is the viscosity of the finished (mixed) glue. If its consistency is too thin, an excess of water beyond that required has been used, and it is best to reject the batch and try again. Similarly, if the consistency is too thick and heavy, an insufficient quantity of water has been used. The water required for various types of casein lies in the following ranges:

Lactic acid casein.....	130 to 170 parts water	
Sulphuric acid casein	}	..... 170 to 220 parts water
Hydrochloric acid casein		
Rennet casein.....	280 parts water	

The silicates of soda that may be used in the formula are the ordinary liquid water-glasses, and should lie within the following analytical limits:

Specific gravity.....	1.38 to 1.42
Density (Baumé scale).....	40.31 to 42.96
Sodium oxide, per cent.....	9.38 to 9.88
Silica, per cent.....	31.41 to 32.38

<sup>1</sup> U. S. Patent No. 1,291,369, granted to S. Butterman, and assigned to the United States Government.

The Air Board specifications employed a formula differing from the above by substituting sodium hydroxide for a part of the hydrated lime, omitting sodium silicate, and introducing sodium fluoride and paraffin oil. It is made up as follows:

Casein.....	100.0 parts
Freshly slaked lime.....	18.0 parts
Commercial sodium hydroxide (not less than 95 per cent pure).....	11.0 parts
Sodium fluoride.....	3.0 parts
Paraffin oil.....	1.5 parts

The above are mixed and are prepared for use by mixing with 200 to 250 parts of water.<sup>1</sup>

This mixture has the great advantage over those previously mentioned in that it acquires a very smooth and limpid consistency which remains in a workable condition for much longer periods of time than any to which sodium fluoride is not added.

The utilization of sodium fluoride in casein glue was probably first introduced for the prevention of the growth of molds or bacteria, and its exceptional value as a liquid stabilizer was discovered only by accident. That it not only possesses such a value, but is also quite unique in this respect seems indisputable. Intensive research has seemed to indicate that the influence of the fluoride ion is specific. It is probable that the sodium fluoride and calcium hydroxide react with each other to some extent forming sodium hydroxide and an insoluble calcium fluoride. There seems, however, to be some kind of a solvent action on the casein that is peculiar to the sodium fluoride. Of course almost any sodium salt that will form sodium hydroxide by double decomposition with calcium hydroxide will dissolve casein, but the interaction with sodium fluoride seems to give a glue of better consistency, higher luster, greater water resistance, and especially longer life than any other salt. We understand that there is at least one American manufacturer who is producing a casein glue in the liquid form which will remain in such a condition indefinitely.

The effectiveness of sodium fluoride as a preservative is not as

<sup>1</sup>Approximately the same composition with the omission of the sodium fluoride is given in U. S. Patent No. 1,310,706 July 22, 1919, to Alfred C. Lindaner, assignor to U. S. A.

marked as might be expected. The employment of Beta-naphthol is finding especial favor as a most efficient preservative. About 2 per cent is used, based on the dry casein content of the glue. Since Beta-naphthol is insoluble in cold water, it is necessary when using it to heat the mixture after the addition of the water.

*The Type of Mixer.*—Mixers used for animal and vegetable glues are not well adapted to the peculiar needs of casein glues. According to the Forest Products Laboratory the essential requisites for a casein glue mixer are: “(1) Rapid agitation and, preferably, different speeds of the paddle; (2) a glue pot that can be readily cleaned—preferably one that can be detached from the machine itself; and (3) a glue pot of metal that will not corrode under the action of alkali. The mixing pot should not be of brass, copper, or aluminum, as the alkali usually present in casein glues will attack these metals. No provision need be made for heating, as casein glues must not be heated.”

A mixer that has proved satisfactory at the Forest Products Laboratory is a power cake-dough mixer of the type used by bakers. It is provided with a double-acting paddle, and may be operated at three different speeds. A sketch of this mixer is shown in the accompanying illustration, Fig. 58.

*The Application of Casein Glue.*—On account of the peculiar limited working life of casein glues they must be handled as soon as possible after being made up. They should, however, if properly made, remain workable for at least four hours, and some will retain their proper consistency for 12 or more hours. As long as the proper “flow” of the liquid is maintained, so that it can be evenly and uniformly spread, it may be used without danger, but when once too thick it should be discarded.

Casein glues work well on the ordinary corrugated roll type of machine spreader. The glue should be applied rather freely, and the excess squeezed off under rollers, or when the pressure is applied. The time allowed between the spreading of the glue and the application of the pressure should not be more than a few minutes, and in no case should the glue be permitted to set before finishing the joint. The pressure usually applied varies from 75 to 100 pounds per square inch, but both higher and lower pressures are also used. The pressure should remain upon the joint for at least an hour, and preferably for a much longer period, as over night. After removing from the presses the joints should



be permitted to "condition" for a few days before being finished if the best results are desired.

The time relations in the working of casein glues have been studied by the Forest Products Laboratory.<sup>1</sup> They report that

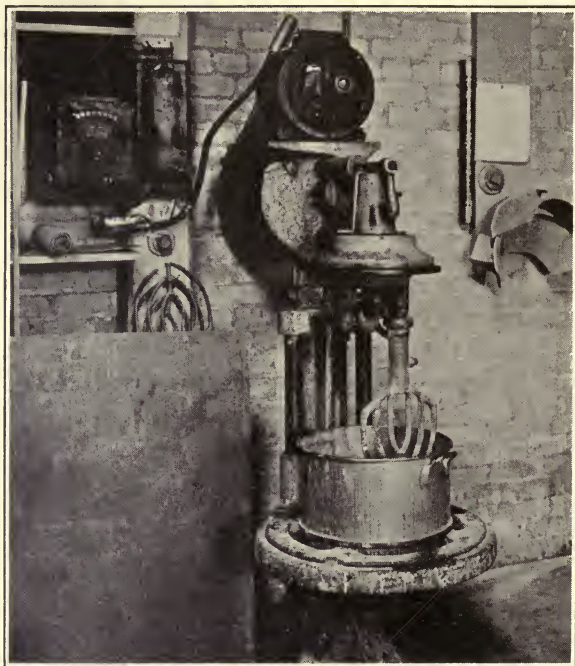

FIG. 58.—Mixer for casein glues. (*Kindness of F. L. Browne, Madison Wisconsin.*)

casein glue joints in spruce proved as strong as the wood after 4 hours, and in hard maple after 6 hours. "When maximum speed of production is essential, such woods may be machined at the ends of the periods stated, without sacrificing the strength of the joint. In some kinds of work, however, machining so soon after gluing is not advisable, because of the danger of warping or the production of sunken joints as the moisture content of the glued wood equalizes.

"Another important fact brought out by the tests on joint strength is that joints released from pressure at the end of two hours and then allowed to season for 22 hours proved as strong as those that had been pressed for 24 hours. Joints pressed for

<sup>1</sup> Forest Products Laboratory, Technical Notes, No. 142 (1921).



only a half hour and seasoned, although of good strength, on the average, were somewhat erratic in this respect and probably would not be dependable where maximum strength is important."

*The Strength and Water Resistance of Casein Glue.*—The strength of casein glues when properly made is high. While inferior to the highest grades of animal glue, they are nevertheless as strong as the wood of most of our common species. Tests made at the Forest Products Laboratory showed shearing strength ranging from 2,000 to 2,500 pounds per square inch.

The exceptional value of these glues is due to the great water resistance which they show. The government specifications required that there should be no separation of plies after boiling in water for 8 hours, or soaking in cold water for 10 days. The shearing strength in plywood was required to be at least 150 pounds to the square inch. The casein glue tests averaged much better than this. After soaking for several days casein glues commonly gave from 20 to 40 per cent of their dry plywood shear strength. Upon redrying, the original strength is largely recovered.

But although casein glues are highly water-resistant, they ultimately decompose when exposed to a damp atmosphere for a long time.<sup>1</sup> The Forest Products Laboratory reaches the conclusion that the decomposition of ordinary alkaline casein glues is not due to the action of bacteria or molds, but rather to a chemical action of the alkali in the glue. This conclusion is based upon the following observations:

Increasing the amount of alkali in the glue increases the rate of decomposition when the glue is kept wet.

Glues containing no sodium hydroxide, although deficient in some important respects, do not decompose as rapidly as similar glues containing sodium hydroxide.

Cultures of molds and bacteria could not be obtained from decomposed alkaline glues.

Some chemicals which have antiseptic properties are found to improve casein glue, but this improvement is due to their chemical action rather than to their toxic properties.

Glues can be completely decomposed in a short time at temperatures above that at which bacteria can grow.

It has been found that copper salts added to casein glues greatly increase their resistance to moisture and also make them more durable when exposed to the action of molds and

<sup>1</sup> Forest Products Laboratory, Technical Notes, No. 138 (1921).

fungi. Casein glues containing copper are nearly as moisture resistant as blood albumin glues.

In the preparation of copper-casein glue at the Forest Products Laboratory,<sup>1</sup> 2 to 3 parts by weight of copper chloride or copper sulphate are dissolved in about 30 parts of water and are added to every 500 parts of the ordinary casein, lime, and water-glass glue. The copper solution is poured into the glue in a thin stream. The violet-colored lumps formed at first by the coagulation of the glue by the copper solution are reduced by stirring vigorously for about 15 minutes, and a smooth violet-colored glue results. It is necessary to add the copper salts after the other ingredients are thoroughly mixed, in order to obtain beneficial results. Copper added to the casein before the lime and water-glass is ineffective.

Glues containing little lime are especially improved by the addition of copper. A low-lime glue with copper may be as resistant to moisture as a glue with more lime in it, and copper does not shorten the "life" or period of workability of the glue so much as would more lime.

*BIBLIOGRAPHY OF UNITED STATES PATENTS ON  
CASEIN ADHESIVES*

- 8,035 April 15, 1851. Chas. A. Broquette, St. Martin, France. Improvement in material for transferring color in calico printing.
- 86,398 February 2, 1869. Joseph Hirsh, Chicago, Ill. Improved adhesive compound and plaster.
- 132,659 October 29, 1872. William Grune, Berlin, Germany. Improvement in transfer paper.
- 169,053 October 19, 1875. Johann G. W. Steffens, Brooklyn, N. Y. Improvement in composition for ornaments.
- 183,024 October 10, 1876. John H. Ross and Charles D. Ross, Albion, N. Y. Improvement in processes of preparing glue.
- 223,459 January 13, 1880. George Vining, Stockbridge, Mass. Assignor of one fourth to E. F. Peck, Great Barrington, Mass. Sizing for paper, etc.
- 241,897 May 24, 1881. Emil R. Von Portheim, Prague, Austria. Manufacture of glue.
- 243,178 June 21, 1881. Emil R. Von Portheim, Smichow, Austria. Process of manufacturing an inspissating and sizing paste from animal proteins.
- 307,179 October 28, 1884. Emery E. Childs, Brooklyn, N. Y. Preparation of casein and of articles made therefrom.
- 307,269 October 28, 1884. Emery E. Childs, Brooklyn, N. Y. Preparation of casein and of articles made therefrom.

<sup>1</sup> Forest Products Laboratory, Technical Note 170 (1922).

- 321,109 June 30, 1885. Karl A. Hohenstein, Brooklyn, N. Y. Assignor to David McMeekan and A. S. Wright, both of same place. Calcimine.
- 377,283 January 31, 1888. Isaac B. Abrahams, New York, N. Y. Manufacture of wall-covering.
- 500,428 June 27, 1893. Edward Rauppach and Leopold Bergel, Gauchtl, Austria. Process of making glue.
- 522,831 July 10, 1894. Peter Cooper Hewitt, New York, N. Y. Process of purifying glue.
- 537,096 April 9, 1895. Carl Wittkowsky, Berlin, Germany. Process of uniting veneers.
- 586,854 July 20, 1897. Wilhelm Majert, Grünau, Germany. Process of making ammoniacal casein.
- 607,281 July 12, 1898. Percy Gerald Sanford, London, England. Mode of preserving albuminous matter.
- 609,200 August 16, 1898. William A. Hall, Bellows Falls, Vermont. Water-proofing compounds.
- 615,446 December 6, 1898. Byron B. Goldsmith, New York, N. Y. Finishing fibrous or absorbent surfaces.
- 619,040 February 7, 1899. Thomas A. Haynes, New York, N. Y. Process of making casein cement.
- 623,541 April 25, 1899. William A. Hall, Bellows Falls, Vit. Sizing
- 632,195 August 29, 1899. William W. McLaurin, Millken Park, Scotland. Assignor to the Smith, McLaurin Co., of the same place. Substitute for leather.
- 633,834 September 26, 1899. Gustav J. Gruendler, St. Louis, Mo. Adhesive.
- 650,003 May 22, 1900. Hermann Bremer, Munich, Germany. Process of dissolving albumin.
- 651,851 June 19, 1900. William A. Hall, Bellows Falls, Vt. Calcimine compound.
- 664,318 December 18, 1900. William A. Hall, Bellows Falls, Vt. Assignor to the Casein Co., of America, N. Y. City. Process of making soluble casein.
- 670,372 March 19, 1901. John A. Just, Syracuse, N. Y. Assignor of three fifths to William D. Carpenter of the same place. Process of producing casein products.
- 681,436 August 27, 1901. Charles H. Bellamy, Philadelphia, Pa. Assignor to M. R. Isaacs of the same place. Manufacture of casein and casein glue.
- 682,549 September 10, 1901. John A. Just, Syracuse, N. Y. Casein powder.
- 684,545 October 15, 1901. William A. Hall, Bellows Falls, Vt. Casein glue.
- 684,985 October 22, 1901. Thomas Alfred Haynes, Hoboken, N. J. Artificial glue or size.
- 692,450 February 4, 1902. John A. Just, Syracuse, N. Y. Assignor of one-half to D. H. Burrell & Co., of Little Falls, N. Y. Adhesive casein and process of making same.

- 695,926 March 25, 1902. William A. Hall, Bellows Falls, Vt. Adhesive.
- 709,651 September 23, 1902. John T. Slough, Woodstock, Canada. Adhesive cement.
- 717,085 December 30, 1902. Henry V. Dunham, New York, N. Y. Assignor to Casein Company of America, N. Y. Casein compound.
- 725,094 April 14, 1903. Winfield M. Kimberlin, Akron, O. Assignor to Goodyear Tire and Rubber Co., of the same place. Process of cementing substances.
- 729,220 May 26, 1903. Frederick Renken, New York, N. Y. Method of gluing articles together.
- 739,657 September 22, 1903. Andrew A. Dunham, New York, N. Y. Assignor to Casein Company of America, N. Y. Sizing and process of producing same.
- 750,048 January 19, 1904. Hezekiah K. Brooks, Bellows Falls, Vt. Assignor to Casein Company of America, N. Y. Casein compound and process of producing same.
- 768,274 August 23, 1904. Pedro Fargas-Oliva, Barcelona, Spain. Process of manufacturing glue or size.
- 788,857 May 2, 1905. Gaston A. Thubé and Louis Preaubert, Nantes, France. Adhesive and method of making same.
- 790,821 May 23, 1905. Henry V. Dunham, Bellows Falls, Vt. Assignor to Casein Company of America, N. Y. Paint and process of preparing same.
- 799,599 September 12, 1905. Frances X. Govers, Owego, N. Y. Assignor to Americus Manufacturing Co., N. Y. Casein glue.
- 809,731 January 9, 1906. Ottokar Henry Nowak, Chicago, Ill. Waterproofing compound.
- 814,594 March 6, 1906. Henry V. Dunham, Bellows Falls, Vt. Assignor to the Casein Company of America, N. Y. Process of precipitating and preserving casein.
- 838,785 December 18, 1906. Mone R. Isaacs, Philadelphia, Pa. Glue or sizing.
- 845,681 February 26, 1907. Alexander Bernstein, Berlin, Germany. Process of making glue substitutes.
- 845,790 March 5, 1907. Mone R. Isaacs, Philadelphia, Pa. Method of treating proteids.
- 845,791 March 5, 1907. Mone R. Isaacs, Philadelphia, Pa. Adhesive compound glues, etc.
- 848,746 April 2, 1907. Mone R. Isaacs, Philadelphia, Pa. Adhesive compound.
- 852,915 May 7, 1907. Julius Talman, Philadelphia, Pa. Assignor of one-half to Charlton H. Royal, Philadelphia, Pa. Process of treating casein and compound obtained therefrom.
- 868,445 October 15, 1907. John A. Just, Syracuse, N. Y. Process of preparing casein soluble to a neutral solution.
- 879,967 February 25, 1908. Mone R. Isaacs, Philadelphia, Pa. Method of treating albumoid and the compository matter obtained therefrom.



- 897,885 September 8, 1908. Henry V. Dunham, Bainbridge, New York. Assignor to Casein Company of America, N. Y. Manufacture of casein.
- 920,959 May 11, 1909. Charles Jovignot, Paris, France. Compository for hermetically closing vessels.
- 959,348 May 24, 1910. Mone R. Isaacs, Philadelphia, Pa. Adhesive compound or sizing.
- 974,448 November 1, 1910. Frederick Supp, N. Y. Assignor to the Arabol Manufacturing Co., of New York, N. Y. Process of liquefying organic colloids.
- 1,015,365 January 23, 1912. William A. Weelands and Eugene Williams, Chicago, Ill. Assignors to Adanio & Elting Company of the same place. Size.
- 1,018,559 February 27, 1912. Richard Heim, Canastota, N. Y. Assignor one-half to Frederick Behrend, New York, N. Y. Process for producing adhesives.
- 1,063,974 June 10, 1913. Mone R. Isaacs, Philadelphia, Pa. Coating composition.
- 1,141,951 June 8, 1915. Andrew A. Dunham, Bainbridge, N. Y. Assignor to Casein Company of America, N. Y. Paper coating composition and method of making same.
- 1,167,434 January 11, 1916. Ludwig H. Reuter, Torreon, Mexico. Process of producing casein and product therefrom.
- 1,192,783 July 25, 1916. Mone R. Isaacs, Philadelphia, Pa. Adhesive composition.
- 1,209,221 December 19, 1916. Noel Statham, Boonton, N. J. Assignor to the Industrial Chemical Co., New York, N. Y. Paper and process of making same.
- 1,209,222 December 19, 1916. Noel Statham, Boonton, N. J. Assignor to Industrial Chemical Company, N. Y. Glazed paper and coating composition therefor.
- 1,235,784 August 7, 1917. Daniel F. Ferney, Grand Rapids, Mich. Glue or adhesive.
- 1,244,463 October 30, 1917. George H. Brabrook, Boston, Mass. Assignor of one-half to Albert T. Fletcher, of the same place. Adhesive.
- 1,291,396 January 14, 1919. Samuel Butterman, Madison, Wis. Assignor to United States of America. Process of manufacturing waterproof adhesives.
- 1,310,706 July 22, 1919. Alfred C. Lindauer, Madison, Wis. Assignor to the United States of America. Waterproof glue.
- 1,347,845 July 27, 1920. Henry V. Dunham, Mt. Vernon, N. Y. Stable casein and process for making same.

## FLUORIDES IN ADHESIVES

- 607,281 July 12, 1898. Percy Gerald Sanford, London, England. Mode of preserving albuminous matter.
- 838,785 December 18, 1906. Mone R. Isaacs, Philadelphia, Pa. Glue or sizing.

- 845,790 March 5, 1907. Mone R. Isaacs, Philadelphia, Pa. Method of treating proteids.
- 845,791 March 5, 1907. Mone R. Issacs, Philadelphia, Pa. Adhesive compound, glue, etc.
- 848,746 April 2, 1907. Mone R. Isaacs, Philadelphia, Pa. Adhesive compound.
- 879,967 February 25, 1908. Mone R. Isaacs, Philadelphia, Pa. Method of treating albuminoids and composition of matter produced therefrom.
- 897,885 September 8, 1908. Henry V. Dunham, Bainbridge, N. Y. Assignor to Casein Company of America, N. Y. City. Manufacture of casein.
- 920,959 May 11, 1909. Charles Jovignot, Paris, France. Composition for use in hermetically closing vessels.
- 959,348 May 24, 1910. Mone R. Isaacs, Philadelphia, Pa. Adhesive compound or sizing.
- 1,192,783 July 25, 1916. Mone R. Isaacs, Philadelphia, Pa. Adhesive composition.
- 1,244,463 December 30, 1917. George H. Brabrook, Boston, Mass. Assignor one-half to Albert T. Fletcher, Boston, Mass. Adhesive.
- 1,347,845 July 27, 1920. Henry V. Dunham, Mt. Vernon, N. Y. Stable casein solution and process for making same.

**2. Blood Albumin Glue.**—Blood albumin glue, like casein glue, was not generally used prior to 1918, but the sudden and imperative demand for water-resistant plywood for military purposes resulted in an intensive study of all possible sources of waterproof glues, and casein and blood albumin were found to be most satisfactory for this purpose.

Blood albumin glue is not placed upon the market in a prepared form chiefly on account of a decrease in the solubility of the albumin with age. But it may be prepared without any difficulty by the consumer from either fresh blood or the dried albumin. If fresh blood is to be used the supply must be readily accessible to the consuming plant, for decomposition takes place very rapidly which unfits the material for glue purposes. It is the more commonly prepared from the dried soluble albumin which is made by coagulating red blood corpuscles and the fibrin and subjecting the clear serum to evaporation under reduced pressure. The temperature must not be allowed to rise above 160°F., as at that temperature the albumin coagulates. The resulting solid residue is ground and sold as dried soluble blood albumin. As the solubility diminishes with age the albumin should be used as a glue only when reasonably fresh.

*Preparation of the Glue.*—A glue may be made that is satisfactory for some purposes by simply dissolving the albumin in water, but the desirable qualities are improved by the addition of ammonium hydroxide and lime, and still other ingredients may be added. If too much lime is used, however, the glue will set very rapidly to a stiff jelly that is not workable.

In putting the material into solution it is advisable to allow it to soak for about two hours before stirring. Water at about 70 to 80°F. should be used. After it is thoroughly soaked it should be agitated until it is of a uniform consistency. There will usually be some insoluble material that will not go into solution, but unless it is excessive in amount or is particularly coarse it may be neglected. It is sometimes advisable however, to strain the mixture through a screen of about 30 mesh wire before using. Blood albumin glues must not be heated in their preparation.

A formula developed by the Forest Products Laboratory<sup>1</sup> for the preparation of blood albumin glue has been found very satisfactory. This is specified as follows:<sup>2</sup>

6 parts of black soluble blood albumin (90 per cent solubility).

11 parts of water at about 80 degrees F.

$\frac{1}{4}$  parts of ammonium hydroxide (sp. gr. 0.90).

$\frac{1}{8}$  part of hydrated lime (from 2 to 3 per cent of the weight of albumin).

After the blood has been put into solution, the ammonia is added while stirring the mixture slowly. The lime is then added in the form of a thick cream, and agitation should be continued slowly for a few minutes. Care should be exercised in the use of the lime, inasmuch as a small excess will cause the mixture to thicken and become a jelly-like mass. The glue should be of moderate consistency when mixed and should be suitable for use for several hours. The exact proportions of albumin and water may be varied to produce a glue of greater or less consistency or to suit an albumin of different solubility than that specified.

*The Application of Blood Albumin Glue.*—Glues made from blood albumin tend to foam in the spreading machines, but if the spreader is allowed to remain stationary except while panels are actually being coated with glue, they may be satisfactorily operated. Since these glues are used almost entirely upon plywood it is important that the glue should be spread by machinery.

The finishing of a joint glued with blood albumin differs from that of all other types in that a high temperature in the press is imperative for the setting of the glue. The high temperature

<sup>1</sup> Patent applied for in the name of S. B. HENNING, Forest Products Laboratory.

<sup>2</sup> Cf. National Advisory Committee for Aeronautics, *Report 66* (1920), 16.

brings about the coagulation of the albumin, and it is this insoluble coagulum which renders the product resistant to the action of either hot or cold water. The heat is most conveniently applied to the wood by pressing the glued plywood in an hydraulic press supplied with hollow platens heated by steam.<sup>1</sup> The coagulation may also be accomplished by placing the clamped joints in a dry kiln or hot chamber at the proper tempera-

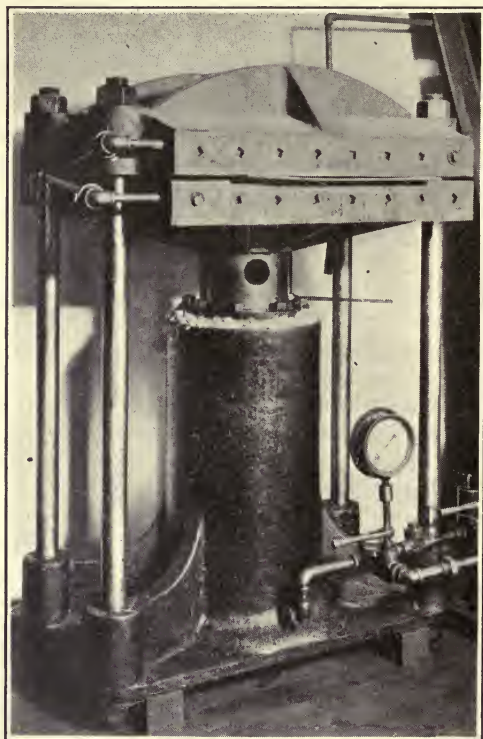

FIG. 59.—Hot press for making experimental panels with blood glue. (Kindness of F. L. Browne, Madison, Wisconsin.)

ture. The temperature of the press or the drying chamber must not be less than 160°F., but in order to hasten the process it is customary to use temperatures of from 200 to 220°F. If temperatures much higher than these are used, however, the moisture in the wood is converted to steam and in forcing its way out of the wood produces blisters or steam pockets between the plies.

<sup>1</sup> F. L. BROWNE, *Chem. Met. Eng.*, **21** (1919), 136.



The pressure employed is commonly from 50 to 100 pounds per square inch, and for a single three-ply panel with  $\frac{1}{16}$  inch face plies three minutes under the press, at a temperature of 212°F., is sufficient. The time required will be greater with lower temperatures, and with increasing thickness of the material joined. Where thick blocks are joined the steam-heated press cannot be used, but the clamped blocks are placed in the heated chamber. The temperature is usually lower than that used in the press so as to prevent an excessive loss of moisture from the wood. On account of this difficulty in heating the joint under pressure, the service of blood albumin glues is mostly confined to plywood manufacture. A press used for experimental work at the Forest Products Laboratory is shown in Fig. 59.

The water-resistant qualities of blood albumin glue surpass those even of casein. After soaking in cold water for several days, or in boiling water for several hours, the shearing strengths of plywood joints show that from 50 to 75 per cent of the dry strength has been retained.

A number of special precautions upon the use of blood albumin glue have been urged by the Forest Products Laboratory:<sup>1</sup>

1. Weigh out all constituents; do not measure them.
2. Add cold water to blood albumin and do not heat mixture.
3. Do not stir blood until it has soaked for from one to two hours.
4. Avoid excessive stirring of the glue or agitation on the spreader, since this produces foamy glue.
5. Load press and apply pressure quickly to prevent coagulation of the blood before pressure is secured.
6. Pressures ranging from 50 to 100 pounds per square inch are advisable, depending upon the glue consistency, nature of wood, etc.
7. Excessively high temperatures of the platens of the press produce steam, causing blisters. A range of 200 to 212°F. is advisable.
8. Panels should be left in the press until the heat has penetrated so as to raise all parts to at least 160°F.
9. Be careful not to use an excessive amount of lime or a strongly alkaline water.

*Dry Glue Process for Thin Veneer.*—A very interesting and important application that has been made of blood albumin glues is the practicability of gluing together very thin veneer ranging from  $\frac{1}{30}$  to  $\frac{1}{125}$  of an inch in thickness. When such thin plies are glued in the ordinary way the glue usually penetrates through the face plies, and a curling, wrinkling, and overlapping occurs

<sup>1</sup> National Advisory Committee for Aeronautics, *Report 66* (1920), 17.

due to the excessive and uneven swelling of the thin veneer from rapid absorption of water.

The blood albumin glue has been adapted to this service by the Forest Products Laboratory. The details of the formulas have not been made public, but the glue mixture is reported to vary from the standard formula previously given "principally in the addition of a substance which makes the glue hygroscopic, or capable of attracting and retaining moisture, sufficiently to give a contact with wood."

The procedure differs from the ordinary operation chiefly in that the blood albumin glue is coated very thinly upon tissue paper or cloth, and in the application this layer is merely spread between the face plies and pressure and heat applied.

To obtain good results, the glue must be mixed thin and be free from lumps or undissolved particles. Straining through a sieve is absolutely necessary in this case. A thin, porous tissue paper is used for coating and is placed in a machine geared to run it through the glue bath at a rate of approximately 1 foot per minute. The tissue paper passes over a roller in the glue bath, and upward into a drying chamber to a worm roller upon which there are strips of felt to prevent it from wrinkling. It then passes over a third roller and through pinch rolls to a final dry roll. Cloth may be used as the medium upon which the glue is dried and then be made to serve as one ply in panel construction.

In manufacturing plywood with the glue, sheets of it are placed between the plies of the wood and pressed in a hot press. A pressure of from 150 to 200 pounds per square inch is necessary in order to bring about good contact between the glue layer and the wood. If the moisture of the veneer is low, the water resistant properties of the plywood may be increased by a slight sprinkling or sponging of the veneer immediately before placing in the press.

The many advantages of this form of glue over the ordinary wet process are summarized by the Forest Products Laboratory:

1. Veneer as thin as  $\frac{1}{125}$  inch may be glued up successfully.
2. Overlaps, wrinkling, open joints, etc., are overcome.
3. Gluing with the addition of little or no moisture overcomes cupping and twisting of panels.
4. Drying of plywood is largely eliminated.
5. Subsequent trouble in checking of veneer in drying is eliminated.
6. Glue is always ready for use and keeps for a long time.
7. It can probably be used more rapidly and with less labor than the wet glue process.
8. No spreader is required.

## II. GLUES OF MARINE ORIGIN

Two very different types of glue are made from parts of the fish. The very highest grades of gelatin may be prepared from the swimming bladders. This product is more nearly water white than any animal gelatin, but it is difficult to entirely remove from it a fishy odor that makes it less desirable for culinary purposes than the animal product. The uncooked sounds are sold as *isinglass*, but after these have been dissolved in water and converted into gelatin it is better known as *fish gelatin*, *isinglass gelatin* or *refined isinglass*. On account of its greater cost it has not been able to compete as an ordinary adhesive with animal glue.

A less desirable product is produced from the skin, scales, heads, and other refuse of fish. These parts may contain much material of a non-protein nature, and are likewise often contaminated with salts, blood, flesh, etc. It is very difficult if not impossible with the use of skin stock, even though selected and treated with great care, to obtain a product of sufficiently high gelatin content to even set to a firm jelly at ordinary temperatures. For this reason the material is commonly sold in liquid form as rather thick viscous fluids. A firmer jelly may be produced from the fish head stock. The natural odor is always strong and offensive, and to mask it and make it less objectionable some aromatic substance of a strong odor as creosote, oil of sassafras, or wintergreen is added.

It should be pointed out that all liquid glues are not fish products, but that animal glues are sometimes treated with a chemical which destroys the power of the glue to form a jelly. Acetic acid and nitric acid are used for this purpose. It is doubtful if this practice is profitable, however, for although a glue is obtained that may be used without warming or other preparation, yet the strength per unit concentration of dry glue is diminished, and the joint is apt to decrease in strength with age. The diminished strength is usually compensated by increasing the concentration at which it is applied, but this can hardly be regarded as an economic procedure. For small repair work and household use it is, however, convenient. The use of calcium or magnesium salicylate and of thiourea have recently been proposed for the preparation of a liquid animal glue.<sup>1</sup>

<sup>1</sup> D. K. TRESSLER, *U. S. Pats.* 1,394,653 and 1,394,654, Oct. 25, 1921.

1. **Isinglass.**—Isinglass (from the Dutch *huisenblas*, German *hausenblase*, meaning sturgeons bladder) is as its name signifies a product composed of the air- or swimming-bladders of certain of the fishes. Most important of these is the sturgeon, and for centuries the material has been obtained and exported from Russia. In many of the fishes this bladder is too small or too securely fastened to the backbone or abdominal wall to make its removal a practical proposition, but the sturgeon, the catfish, and the carp have long been utilized for this purpose.

More recently many other of the fishes have been made use of for the manufacture of isinglass. The siluridæ are used in Brazil and Venezuela. Iceland exports a good quality made from cod sounds, and the cod is also used to some extent in Norway and in Canada for this purpose. The North American product is obtained chiefly, however, from the large hake that are found in deep water. Over 100 tons of hake sounds were obtained annually on the New England coast alone a few years ago, but the production is much less at present. The squeteague has also been much used, and the tilefish has been demonstrated to be well adapted to the production of isinglass.<sup>1</sup> The yield and quality of the product varies greatly, however, with the specie of fish. The large deep-water hake yield from 40 to 50 pounds of dry isinglass per ton of fish, and the product contains about 85 per cent of gelatin. The smaller shallow-water hake yield only about 30 pounds of isinglass per ton of fish. The cod yields but 15 to 20 pounds, and the squeteague 20 pounds. The gelatin content of the product from the latter two species is also low, being only about 50 per cent.

*The Manufacture of Isinglass.*—Isinglass appears on the market in several different forms. The best Russian product is known as *staple isinglass* and may be obtained as long or as short staple. It is made by rolling each bladder and folding around a few pegs set in the form of a horseshoe. The leaves are sometimes twisted like ropes. When the bladders are merely placed one upon the other in sheets it is known as *leaf isinglass*. If these leaves are folded before they are completely dry, and covered with a damp cloth, they constitute *book isinglass*.

The preparation of the material for the market is very simple. The Russian method is as follows: The sounds are allowed to remain in water for several days with frequent changes of water to

<sup>1</sup> G. F. WHITE, U. S. Bureau of Fisheries *Doc.* 852 (1917), 7.



remove the blood and fatty matter present. After the washing is complete the sounds are cut longitudinally into sheets. These are laid out to dry by exposure to the sun and air upon boards of linden or bass-wood. During this process the inner layer, which is the layer consisting of pure isinglass, is uppermost, and after a partial drying it may be removed from the coarser external lamellæ. The finer sheets are placed between cloths to protect them from the flies, and are subjected to heavy pressure to flatten them. After thoroughly drying they are assorted and tied up into packages for export containing 10 to 15 sheets and weighing about  $1\frac{1}{4}$  pounds. These packages are commonly shipped in lots of eight sewed up in a cloth bag or inclosed in sheet lead.

The external layers are softened with water and a considerable amount of gluey material scraped off which is moulded and dried. This is used as an inferior isinglass. The residue, together with trimmings from the sounds and other parts of the fish, is boiled with water to produce a fish glue.

The preparation of isinglass in this country differs from that outlined above chiefly in the introduction of machinery for the hand labor. The sounds, especially from the hake, are often detached on the fishing vessels when dressing the fish, and are then salted in barrels so that they will not decompose. They are sometimes air-dried in that condition. Upon delivery to the isinglass manufacturer they are first soaked for several hours in water to soften them, washed, slit open and the black outer membrane scraped off, and again thoroughly washed. The pure sounds are then usually run into a cutting machine provided with a roller and a set of knives in which they are chopped into small pieces. This material is mixed and macerated between rollers, and then passed to the sheeting rollers. These are hollow iron rollers through which cold water is allowed to circulate to prevent a softening and sticking of the sounds. A thick sheet is formed which passes in turn to the ribbon rollers where it is drawn out into a thin uniform ribbon  $\frac{1}{64}$  inch in thickness and 6 to 8 inches in width. The ribbons are suspended in warm rooms where they dry out in a few hours, and are then rolled on wooden spools into coils weighing less than a pound each. The recovery of isinglass by this method is about 80 per cent of the weight of the original sounds.

The drying of the sounds; the rolling of the sounds; the drying

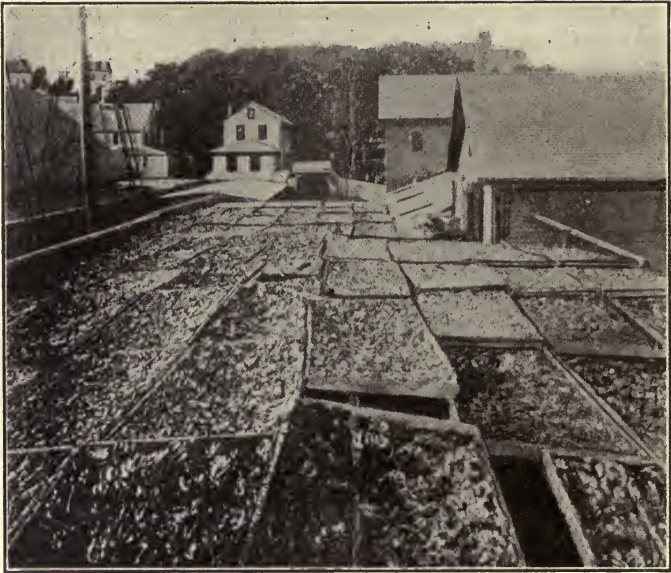

FIG. 60.—Drying Hake sounds for isinglass manufacture. (*By permission of Bureau of Fisheries, Washington, D. C.*)



FIG. 61.—Rolling Hake sounds for isinglass. (*By permission of the Bureau of Fisheries, Washington, D. C.*)

room; and final rolling of the isinglass into coils are illustrated in the accompanying photographs, Figs. 60, 61, 62, 63.

A product obtained by dissolving New England isinglass in water, straining off the insoluble material, and spreading in very



FIG. 62.—Drying room of isinglass factory. (By permission of the Bureau of Fisheries, Washington, D. C.)



FIG. 63.—Wooden spool for rolling into coils. (By permission of the Bureau of Fisheries, Washington, D. C.)

thin sheets on oil cloth or glass, is known in the trade as *transparent* or *refined isinglass*.



*The Composition, Properties, and Uses of Isinglass.*<sup>1</sup>—The composition of isinglass from various sources has been reported by Prollius,<sup>2</sup> and is given in the following table.

TABLE 46.—COMPOSITION OF ISINGLASS

Source of isinglass	Ash, per cent	Water, per cent	Residue insoluble in hot water, per cent
Astrakhan (Russian).....	0.20	16.0	2.8
Astrakhan (Russian).....	0.37	18.0	0.7
Astrakhan (Russian).....	0.20	17.0	1.0
Astrakhan (Russian).....	0.80	19.0	3.0
Astrakhan (Russian).....	0.50	19.0	0.4
Astrakhan (Russian).....	0.40	17.0	1.3
Hamburg.....	1.30	19.0	2.3
Hamburg.....	0.13	19.0	5.2
Iceland.....	0.60	17.0	21.6
East India.....	0.78	18.0	8.6
Yellow, unknown source.....	2.30	17.0	15.6

The high reputation which the Russian product enjoys is shown by the above table to be quite justified. The insoluble matter and ash are low, and the analyses run reasonably uniform. A certain amount of matter insoluble in hot water will always be found, but in the best grades it is low.

On soaking in cold water, isinglass swells uniformly but slowly, and does not take up nearly the amount of water that will be absorbed by a similar weight of gelatin. The isinglass, it must be remembered, is not gelatin but rather collagen, and in order to convert it into gelatin a brief heating in water is necessary. If a gelatin is made and allowed to dry out, the product will then possess all of the characteristics commonly associated with gelatin. Its jelly strength will be fairly high, it will be clear and almost colorless, and produce a glue of high adhesive value. A distinctive odor will always be present unless some material has been added which serves to mask that odor by imparting to it a stronger, although less disagreeable one of another character.

<sup>1</sup> For chemical composition, see pages 28, 43, 46, and 435. For the strictly medicinal uses of isinglass the reader is referred to Potter's "Materia Medica."

<sup>2</sup> F. PROLLIUS, *Dingler's polytech. J.*, 249 (1884), 425.



In its several tests it responds in a way entirely similar to animal gelatin.

Since isinglass is more expensive than gelatin, attempts have frequently been made to adulterate it. One of these methods is by rolling a layer of gelatin between layers of isinglass. White<sup>1</sup> reports that such adulteration may easily be detected by treating with water and observing the nature of the colloidal solution under the microscope. The isinglass will retain its characteristic fibrous structure which is not present in a gelatin solution, and the gelatin becomes more transparent than before, the shreds becoming disintegrated.

In addition to adulteration, imitation is sometimes attempted by putting out material that is intended to simulate the true isinglass, but which is made from altogether different material. Thus blood fibrin, calves' foot gelatin, agar agar, etc., have been manufactured to resemble natural isinglass.

One of the oldest and best established uses of isinglass is as a clarifying agent for various beverages as wine, cider and malt liquors. The efficacy of the isinglass for this service lies in the purely mechanical property it possesses of maintaining a fibrous structure in the solution, and as this settles slowly to the bottom it entangles in its netlike meshes the colloidal bodies that produce the undesirable turbidity. For clarifying wine the isinglass is first swollen in water and then in the wine until it is completely swollen and transparent. It is then thoroughly beaten into a small amount of the wine, strained through a linen cloth, and stirred into the rest of the wine. The temperature is kept low and the isinglass does not go into solution, but only into a very finely divided suspension. Thus the original fibrous structure of the sounds has at no time since it came from the fish been lost. In this lies the difference in the action of isinglass and gelatin for fining. If isinglass were heated and made into a true gelatin it would then have lost the properties which make it so valuable for this service. A single ounce of isinglass will clarify, under the optimum conditions, 500 gallons of wine in 10 days.

In the manufacture of beer and ale the starch granules, bacteria, and protein matter, which do not settle in the tanks after the primary fermentation, are gotten out by either filtration, adsorption upon wood chips, or fining. In the latter

<sup>1</sup> G. F. WHITE, *loc. cit.*

procedure the isinglass is treated with sour beer and, after swelling, macerated as in the fining of wine. After straining it is mixed thoroughly with the rest of the beer. One pound of isinglass will fine from 100 to 500 barrels of beer.

Other uses of isinglass are somewhat scattered. Court plaster frequently employs isinglass instead of gelatin, the proportions used being 10 grams of isinglass, 40 grams of alcohol, 1 gram of glycerine, and water to make a total weight of 120 grams. Taffeta is first treated with successive layers of isinglass in water, then with the isinglass, water, alcohol and glycerin solution, and the reverse side covered with tincture of benzoin. This is sufficient for a piece 38 cm. square.

Various cements for repairing glass, pottery, etc., are made of isinglass with alcohol and gums. A formula for a cement of the following composition has been published:

10 grams isinglass  
5 grams gum ammoniac  
5 grams mastic  
80 grams alcohol

The isinglass and gums are said to be dissolved separately in the alcohol and then heated together over boiling water.<sup>1</sup>

Where a high luster is desired on textile goods isinglass is sometimes used, mixed with gum, as a size. Some silks are sized in this way. Mixed with pyroxylin and dissolved in acetic acid, with the addition of a little formaldehyde or potassium bichromate, it has been employed as a waterproofing composition for textiles. Isinglass dissolved in water is used to repair leather belts that have torn apart.

**2. Liquid Fish Glue.**<sup>2</sup>—Fish glue is marketed usually in the form of liquid glue and it is the most important liquid glue. Dry fish glues are soluble in water at ordinary room temperatures,

<sup>1</sup> A vast number of formulas for the preparation of special cements, insoluble or water-resistant glues, and glues for special purposes have been published. Some of these are undoubtedly workable and satisfactory, but a considerable number of them are either unworkable or unsatisfactory. For example, the above formula calls for a solution of isinglass in alcohol. Since alcohol is a precipitant for gelatin, it is obvious that such a solution cannot be obtained. It is probable that an emulsion of an aqueous solution of the isinglass in the alcohol is indicated.

<sup>2</sup> By DONALD K. TRESSLER, Ph. D., Industrial Fellow of the Mellon Institute of Industrial Research, University of Pittsburgh, Pittsburgh, Pa.

whereas hide and bone glues merely swell but do not dissolve under these conditions. Hide and bone glues are occasionally made into liquid glue; but, in order to do this, the hard glues must be either dissolved in a solution of a gel-inhibiting substance or so treated that their chemical composition and properties are changed.

*Source of Raw Materials.*—The bulk of the fish glue manufactured today is made from the waste products of the cod, haddock, cusk, hake and pollock industries. These fish are the so-called "ground" fish which are caught on the banks, usually together in the same nets, and cleaned on the same wharves. Consequently, most of the fish glue stock comes to the glue factory already mixed; that is to say, the waste from the various species of fish have been dumped into the same containers.

Some other species of fish than those mentioned above are used in the manufacture of glue—indeed, any fish might be used for the making of glue—but for certain practical and economical reasons only small quantities of glue are manufactured from other fish. The quality of the glue prepared from these ground fish is higher and the yield is greater than in the case of glue made from most other fish. Many species of fish—*e.g.*, menhaden,—yield such small quantities of glue that it is not economically practicable to use them for the manufacture of glue. Other fish such as the herring and mackerel contain such large quantities of fat that special procedures must be followed to remove the fat from the fish in the glue making process. Many fish which would otherwise be used are not caught largely in any one locality and consequently the supply of fish waste at any particular point is not large enough to justify the establishment of a glue factory. Other fish are caught only for short seasons, which would cause the glue factories to be idle most of the year.

The ground fish waste ordinarily is divided into three classes: *viz.*, (1) fish heads, (2) waste, *i.e.*, salt fish trimmings and bones, and (3) skin from the dried salted fish. The fish heads are fresh and are hauled from the wharves where the ground fish are cleaned. With the exception of the exported salt fish, most of the dried salt fish is skinned before it is packed for shipping. The cod and cusk skins are not mixed with the skins of the haddock, hake and pollock. The cod and cusk skins which have a small amount of salt fish adhering to them constitute the skin-glue stock. Most of the salt fish sold in this country is cut into strips,



trimmed of the outer yellow portion and freed from bones. The trimmings, the bones, and the haddock, hake and pollock skins constitute the salt-fish waste glue-stock and is termed "waste."

*Methods of Manufacture.*—The glue stock, regardless of its source, must be freed from salt or freshened before being made into glue. The *fish skin* and *waste* stock being a waste product of the salt fish industry, contains a much greater percentage of salt and consequently more care must be used in freshening it than in freshening the fish head stock. The fish skin and waste stock ordinarily are agitated in running water in large tanks for a period of twelve hours or more, or until a sample of the wash-water on analysis shows a low percentage of chlorides. The stock is then thrown into false-bottomed tanks, called "cookers," which usually have a layer of excelsior on their false bottoms. The stock is covered with water and a slow stream of steam is passed into the tanks. The length of the cooking period varies with the nature of the glue stock, fish waste requiring longer cooking than fish-skin stock. Usually two runs are made; that is, the liquor formed by the cooking of the stock is drawn off when it becomes sufficiently concentrated, more water is added and the cooking is continued. The average concentration of the glue liquors is about five per cent. The first run of glue liquor is the better.

After 6 to 10 hours cooking, when nearly all the glue has been removed from the stock, the cooking is stopped and the second run of glue liquor is withdrawn. The residue in the cookers usually is put in large hydraulic presses, where most of the remaining glue liquor is pressed out. This press-glue liquor is added to the second run liquor.

Preservatives are added to the glue liquor to prevent any bacterial action. Fish glue and glue liquors decompose very rapidly if any considerable amount of bacterial growth in them is permitted. The preservatives added by various glue makers include phenol, cresol and boric acid. The finished product contains from 0.5 to 3 per cent of preservatives, the amount depending upon the nature of the preservative added.

The glue liquor, drained from the cookers, is next pumped to the evaporators. The types of evaporators used vary in different factories. Some plants use open pans heated with steam coils, others use open pans containing revolving copper coils, and still others use vacuum pan evaporators. The glue liquors usually



are strained through a coarse wire screen. The liquors are evaporated to a uniform viscosity and, just before the glue is run into the storage tanks, a sufficient amount of some essential oil dissolved in ethyl alcohol is added, to prevent the growth of moulds. The essential oils used depend upon the custom of the glue maker and on the use to which the glue is to be put; oils of cassia, camphor, clove, wintergreen and sassafras are among those employed. These essential oils have a dual purpose, for, in addition to preventing the growth of moulds, they mask the fishy odor of the glue. Some fish glues also are made opaque by the addition of zinc-white or some other white pigment.

The processes by which the *fish heads* are converted into glue usually are kept more or less secret. The processes are for the most part similar to that outlined above, except that the glue stock is digested with dilute acids, usually hydrochloric or acetic acid, instead of cooking with steam alone. Moreover, the stock and glue liquors usually are bleached well. Sulphur dioxide and sodium bisulphite are the common bleaching-agents. Fish-head glues generally are made opaque with a white pigment.

The residue, "*chum*," from the hydraulic presses is dried and marketed either as chicken feed or as a fertilizer. This material makes a very satisfactory chicken feed as it contains approximately fifty per cent of protein. Then, too, the fish head and waste chum contain a high percentage of calcium phosphate which supplies lime for the egg shell and phosphorus for the egg yolk.

Various fish glue makers market their glue in different ways. Some cater to the trade buying liquid glue in bulk, others market it chiefly in small bottles and cans; but the following three grades can be purchased on the market: (1) photo-engraving glue, which is made from the first-run glue liquors from fish skin. (2) fish skin and fish waste glue which is usually sold in small bottles and small cans; and (3) fish head glue, which is prepared from fish heads and ordinarily is marketed in large cans and barrels.

*Practical Tests to Determine the Quality of Fish Glue.*—Fish glue of the ordinary viscosity contains from 50 to 55 per cent of glue and weighs from  $9\frac{1}{2}$  to 10 pounds to the gallon.

There is a considerable quantity of fish glue on the market which is of rather doubtful quality. Consequently, if the glue user does not test his glue, it is wise to buy only from manufacturers with well-established reputations.

The best fish glues have a gel point of about 7.5°C. A higher gel point is satisfactory in warm weather, but is unsuited for outdoor use in cool weather. Glues with lower gel points are usually weak. Fish glues should not contain more than 0.2 per cent of sodium chloride, as a higher salt content indicates a poor drying, hygroscopic glue which, while affording satisfactory joints in cool dry weather, probably will weaken in humid weather: it is for this reason that the purchaser should be very careful of the quality of fish glue which he buys. The titration of an ashed sample of dried fish glue with a standard silver nitrate solution using potassium chromate as an indicator will determine the chloride content. All fish glues should be slightly acid to phenolphthalein.

One of the most instructive tests which may be conducted in the examination of a fish glue is the drying test. This is carried out preferably by spreading a uniform layer of glue, about  $\frac{1}{8}$  inch in depth, on a glass plate and placing the plate in a constant-humidity and temperature room, together with a similar layer of a standard glue of known hygroscopic properties. A room having a constant temperature of 20°C., and a constant humidity of 20 per cent will be satisfactory. The time of drying and the hardness of the dried film are noted and compared with the standard. The dried films should then be placed in a room having a higher humidity and temperature. A very exacting test may be conducted by choosing a room having a temperature of 25°C., and 80 per cent humidity. Under such conditions most fish and bone glues will soften slightly. If the dried glue film becomes liquid or sticky under these conditions, a poor glue is indicated. If constant temperature and humidity rooms are not available, large humidors containing sulphuric acid of the proper dilution may be used.

The joint strength tests, as ordinarily applied, are not of much value in determining the quality of a given sample of fish glue, inasmuch as the temperature and humidity at which the tests are conducted are the controlling factors in the strength of the joints. The personal equation is also an important factor which should be considered in comparing results of joint tests. However, if the laboratory worker conducts all the joint strength tests under the same conditions of temperature and humidity, the results of these tests become valuable. The results are particularly useful if these tests are made under humid condi-

tions. A constant temperature and humidity room should be so regulated that the temperature is in the neighborhood of 25°C., and the humidity about 80 per cent. The wood blocks and the joints should be kept in this room or in a humidor having similar conditions of temperature and humidity. Under the conditions mentioned above, good fish-skin and fish-waste glues possess about the same tensile strength as high grade bone and low grade hide glues, whereas fish-head glues are about as strong as medium grade bone glues.

*Composition.*—Until more work has been done on the composition of fish glue, a complete analysis of the 50 per cent of dry matter contained in liquid fish glue will be of little value in indicating the quality of the glue. Fish glues differ in composition from hide and bone glues, in that fish glues are composed chiefly of proteoses and peptones with a smaller proportion of proteins, whereas the higher grade of hide glues are nearly pure gelatin, and bone glues consist mainly of gelatin and proteoses.<sup>1</sup> The proteins of fish glues are higher in ammoniacal nitrogen, melanin and non-amino nitrogen than the proteins of either hide or bone glues. The composition of the proteins of fish glue resembles more closely that of the proteins of bone glues than that of the proteins of hide glues.<sup>2</sup>

Dry fish-skin and fish-waste glues contain about one per cent of ash. The amount of ash contained in fish-head glues varies widely, depending on the method of manufacture used and the amount of pigment or other inorganic material added during the manufacture of the glue. Samples which have been analyzed by the writer contained from 1 to 5 per cent of ash in the dry glue. A representative analysis of a sample of ash from a fish skin glue is given below:

	PER CENT
Ash in dry matter.....	0.96
Analysis of ash	
Silica (SiO <sub>2</sub> ).....	12.7
Calcium oxide (CaO).....	10.5
Magnesia (MgO).....	trace
Potash and soda (K <sub>2</sub> O and Na <sub>2</sub> O).....	13.9
Sulphur trioxide (SO <sub>3</sub> ) <sub>2</sub> .....	34.0
Phosphorus pentoxide (P <sub>2</sub> O <sub>5</sub> ).....	24.9
Chlorine (Cl).....	3.2
Ferric oxide (Fe <sub>2</sub> O <sub>3</sub> ).....	<u>trace</u>
	99.2

<sup>1</sup> See table 10 on page 28.   <sup>2</sup> See table 14 on page 48.

III. COMPARISON OF VARIOUS GLUES<sup>1</sup>

Particular compared	Animal glue	Casein glue	Vegetable glue	Blood glue	Liquid glue
Source.....	Animal hides, bones, etc.	Casein from milk.	Starch—g e n e r a l l y casava.	Soluble dried blood.	Animal glue, or skins, bones, etc., of fish.
Cost per pound (Apr., 1921); (vencer glue prices for carload lots).	High grade, 29 to 45 cents per pound; vincer grades 19 to 30 cents per pound.	Casein, 16 to 20 cents per pound; prepared casein glues, 18 to 26 cents per pound.	Prepared glue, 7 to 12 cents per pound, starch 8 to 9 cents per pound.	Dried blood, about 20 cents per pound.	\$1.50 to \$2.50 per gallon.
Spread <sup>2</sup> Extremes reported: Common range:	20 to 45 25 to 35	30 to 80 35 to 55	35 to 70 35 to 50	30 to 100	No data.
Mixing.....	Soaked in water, then melted.	Mixed cold with rapid stirring.	Mixed with alkali and water, with or without heat; can be made without alkali.	Mixed cold.	Requires no preparation.
Application.....	Applied warm with brush or mechanical spreader.	Applied cold with brush or mechanical spreader.	Applied cold with mechanical spreader.	Applied cold by hand or with mechanical spreader.	Applied cold or warm; usually by hand.
Temperature of press....	Cold; hot cauls frequently used.	Cold.	Cold.	Hot.	Cold.
Strength (block shear test).	High grade equal in shear strength to strongest American woods; medium grades slightly lower.	Similar to medium grade animal glue.	Similar to, or slightly less than medium grade animal glue.	Similar to or slightly less than medium grade animal glue.	Good grades similar to medium grade animal glue; some brands very weak.



	Low.	High.	Low.	High.	Low.
Water resistance.....	Does not stain.	Stains thin veneer of some species.	If mixed with caustic soda, stains thin veneer of some species.	Does not stain but the glue is very dark; dry process glue does not show through.	Does not stain.
Staining.....	High grade, where a strong joint is desired; low grade, sometimes used for veneering, especially if it is desired to prevent staining.	Mainly where water resistance is desired in veneered or joint work.	Mainly in veneered work on account of cheapness, but also somewhat for joint work.	Almost entirely for water resistant plywood for aircraft purposes, and for articles to be moulded after boiling in water.	Mainly for repair work and gluing small articles by hand.
Uses in woodworking....	Sizing of paper and textiles, as a binding agent, and in the manufacture of jellies as for printers rollers.	Sizing and filling of paper, and for sizing reed furniture.	Adhesive in the paper box and paper adhesive trade.		Size and adhesive in paper box and paper adhesive trade.
Principal other uses.....					

<sup>1</sup> Taken mainly from National Advisory Committee for Aeronautics, *Report 66 (1920)*, 21.

<sup>2</sup> Expressed in square feet of glue line per pound of dry glue for veneer work.

As has been mentioned previously, the chlorine content of the ash is often an index of the hygroscopic properties of the fish glue. Ash analyses of fish glues may be of value in detecting adulteration; moreover, it is often possible to distinguish between liquid glues prepared from hard glues and liquid fish glues by the differences in the composition of the ash.

*Properties.*—The color of liquid fish glue depends upon the nature of the raw material, the method of manufacture and the clarity of the product. Fish-skin glues, as they are ordinarily produced, possess the greatest degree of clarity. Fish-waste and fish-head glues are more or less opaque. Most clear fish glues make a dark joint when used with light colored woods, and consequently much of the liquid glue on the market contains some white pigment. This gives the glue a lighter color and also makes the joint less conspicuous.

The odor and taste of fish glues depend largely upon the nature and amount of preservatives and essential oils added. Upon heating for some time, the essential oil is driven off and the true odor of the fish glue becomes more apparent.

The "speed of set," or the time elapsing after the application of a coat of glue until the glue becomes a gel, depends upon the gel point and viscosity of the liquid glue, the amount of glue applied, the nature of the wood, and also, to some extent, the humidity of the atmosphere. "Setting" is caused by a partial withdrawal of the moisture of the glue, thus causing the gelling of the liquid glue. The higher the viscosity and gel point of the liquid glue, the less the amount of glue applied, the more absorbent the surface to which the glue is applied, and the lower the temperature and humidity of the atmosphere, the more rapidly does the glue "set."

At any given temperature and humidity the rate at which a fish glue dries depends upon the source of the glue, the method of manufacture, and the salt content. As a rule, fish-skin and waste glues dry more rapidly than fish-head glues, although if the fish-skin and waste glues contain an abnormally high salt content this may be reversed.

The viscosity of liquid fish glue depends upon the source of the glue, the method of manufacture, the percentage of dry glue in the liquid glue, the temperature, and the addition of substances other than fish glue, *e.g.*, boric acid, hard glue, phenol and cresol. The addition of boric acid increases the viscosity of liquid fish

glue to some extent; whereas the addition of phenol and cresol decrease the viscosity. Small amounts of hard glues, *i.e.*, animal glues, sometimes are added to increase the viscosity.

Fish-head glues are usually more flexible than skin and waste glues. Glycerine and glucose often are added to increase the flexibility of glues.

Properly preserved liquid fish glues will keep indefinitely in an air-tight can or well-stoppered bottle. If the glue is stored in a cold room it will gel. This gel melts quickly as soon as the glue has been warmed above its gel point. When liquid glue containing phenol or cresol is put up in tin cans, after a time a black ring is formed around the top of the can where the phenol or cresol has attacked the iron. However, this does not injure the quality of the glue. Precipitates sometimes settle out from poorly prepared liquid glue, but this settling does not injure the strength of the glue.

*Uses.*—The best grade of fish-skin glue is very satisfactory for the production of half-tone plates for photo-engraving work. It is also used to some extent in the production of zinc line plates for photo-engraving work. Fish glues are used largely where flexible glues are required, *e.g.*, in the manufacture of court-plaster, labels and stamps, and in the binding of books. Where small amounts of a strong, ready-to-use, adhesive is needed, fish glues are universally used; *e.g.*, for small repair jobs about the house, for shoe repairing and general repair work. Some fish glue is blended with hide glue and used as belt cement for leather belts. Large quantities of fish-head glue are used in various sizing operations, for this glue stiffens material yet is somewhat flexible. Some fish glue is used in the chipping of glass in the production of translucent glass. Large quantities are used in box making, furniture making, and for general joining work.

#### A SELECT BIBLIOGRAPHY ON FISH GLUES

ANON, Isinglass, ichthyocolla, fish glue, *Farben-Ztg.*, **26** (1921), 1913; *Chem. Abstracts*, **15** (1921), 2562.

CLARK, E. D. and ALMY, L. H., A study of food fishes, the complete analysis of twenty common food fishes with special reference to a seasonable variation in composition, *J. Biol. Chem.*, **29** (1917), xxii; *Chem. Abstracts*, **11** (1917), 3065.

DIETERICH, K., The pharmacodiascosmy and chemical analysis of sturgeon and fish bladders, *Chem. Ztg.*, **33** (1909), 357; 368.

EKMAN, C. D., Extraction of glue from fish, hides, or bones, *Brit. Pat.* 2,680 (1883).

GAMBLE, C. W., On the properties of certain collagenous bodies, and their behavior towards light when associated with alkali bichromates, *J. Soc. Chem. Ind.*, **29** (1910), 65-9.

GREEN, E. H. and TOWER, R. W., The organic constituents of the scales of fish, U. S. Fish Commission *Bull.* 21 (1901), 97.

GROTH, L. A., Preparation of liquid glue from fish, *Brit. Pat.* 5,786 (1882).

KNUDSEN, Manufacture of fish glue, *Brit. Pat.* 153,526 (1920).

LINDEMUTH, J. and PARKER, E., Analysis of fish scrap, *J. Ind. Eng. Chem.*, **5** (1913), 388.

MÖRNER, A study of fish scales, *Z. physiol. Chem.*, **24** (1897), 125; **37** (1902), 88.

Naamlooze Vennootschap Allgemeene Uitrinding Exploitatie, Preparation of protein from fish, *Brit. Pat.* 7,700 (April 1, 1913).

Naamlooze Vennootschap Allgemeene Uitrinding Exploitatie, Preparation of proteoses from fish, *Brit. Pat.* 22,462 (Oct. 6, 1913).

OKUDA, Y., Hydrolysis of fish gelatin, *J. Coll. Agr. Imp. Univ. Tokyo*, **5** (1916), 355-63; *J. Soc. Chem. Ind.*, **36** (1917), 513.

OKUDA, Y., Quantitative determination of creatine, creatinine, and mono-amino-acids in some fishes, mollusca, and crustacea, *Orig. Com. 8th Intern. Congr. Appl. Chem.*, **18**, 275-81; discussion of same, *ibid.*, **27**, 161-2.

OKUDA, Y. and OYAMO, K., Hydrolysis of fish muscle, *J. Coll. Agr. Imp. Univ. Tokyo*, **5** (1916), 365-72; *Expt. Sta. Rec.*, **40** (1919), 171; *Chem. Abstracts*, **14** (1920), 1373.

PROLLIUS, F., The composition of isinglass, *Dingler's. polytech. J.*, **249** (1884), 425.

SCHWICKERATH, K., A proteose preparation from fish, *Brit. Pat.* 1,343, (Jan. 20, 1908).

VIKTORIN, H., *Die Meeresproducte*, Hartlebens Verlag, Wein & Leipzig (1906).

WHITE, G. F., Fish isinglass and glue, U. S. Bureau of Fisheries, *Doc.* **852** (1917).

WILLIAMS, K., Cooking and chemical composition of some English fish, *Chem. News*, **104** (1911), 271; *Chem. Abstracts*, **6** (1912), 516.



## CHAPTER VIII

### THE TESTING OF GLUE AND GELATIN

All things recently glued together  
are weak and easily pulled asunder.  
Cicero (about 50 B.C.)

	PAGE
1. The Jelly Strength or Consistency .....	369
The Early Methods of Making the Jelly Strength Test .....	369
The Later Methods for Measuring Jelly Consistency .....	373
2. The Viscosity .....	380
The Theory of Viscous Flow .....	381
The Capillary Tube Type of Viscosimeter .....	384
The Rising Bubble and Falling Sphere Types of Viscosimeter .....	392
The Torsional Type of Viscosimeter .....	394
3. The Melting Point .....	399
The Scientific Basis of the Melting Point Test .....	400
The Methods for Measuring Melting Point .....	404
4. The Adhesive Strength .....	411
5. The Tensile Strength and Elasticity .....	411
6. The Optical Rotation .....	413
7. The Swelling Capacity .....	415
8. The Rate of Setting .....	416
9. The Foam Test .....	416
10. The Grease Test .....	418
11. The Reaction .....	419
12. The Appearance, Odor, Color, Keeping Qualities, etc. ....	420
The Inspection Test .....	421
Crazed Glue .....	422

As gelatin and glue are used for a large variety of purposes, and as their application to the arts dates back to the time of the ancients, there have been proposed from time to time a great many tests intending to determine the relative value of the material for its several uses. Glue is not a simple substance, fixed and invariable in its properties. One may not order "pure glue," as he would, for example, pure linseed oil, or pure slaked lime. It is perfectly well known to everyone who has handled the material that there is good glue and bad glue, strong glue and weak glue, sweet glue and sour glue, hide glue and bone glue, brown glue, yellow glue, and white glue—in fact if one orders just plain *glue* he may get anything from *size* to *isinglass*,

and pay anywhere from five cents to a dollar per pound. And if we consider for a moment the divers ingredients that go to make up the various types of glue, it will not seem at all surprising that such is the case.

In spite of this, however, the manufacturing process has vastly improved in the last 30 years. There was a time when every conceivable part of the animal that could not be utilized for more valuable products was "dumped" into the glue kettle. Very little precaution was exercised to prevent decomposition, and the whole heterogeneous bacteria-laden mess was boiled down for "glue." But, as an inspection of the preceding chapters will reveal, that method is a thing of the past, and the industry is beginning to operate on a scientific basis.

Notwithstanding this improvement, however, or perhaps in part because of it, many different types of product are now produced. The heavy bones, the light bones, the "green" bones, the "steamed" bones, the country bones, the heads, the feet, and the bones from different animals, are all, for the most part treated separately, and result in different types of glue, as are also hide pieces, fleshings, leather scrap, tendons, and the like. And, as has also been shown, each of these lots is digested a number of times with fresh portions of water, which still further increases the number of different quality glues.

The tests that have been applied are each based upon some property that has been believed to be of fundamental importance in estimating the suitability of the particular glue to a particular usage. These tests may be divided into the two general classes: physical tests upon some property, and chemical analysis for some constituent. The former will be considered in this chapter. Little attempt will be made in this place to discuss the relative merits of the tests to be described, nor to present means by which improvement could be introduced. For a consideration of these points the reader is referred to Chap. X.

The several physical tests which are in common use, both in this country and abroad or which have been proposed, are as follows:

1. The Jelly Strength or Consistency.
2. The Viscosity.
3. The Melting Point.
4. The Adhesive Strength.
5. The Tensile Strength and Elasticity.

6. The Optical Rotation.
7. The Swelling Capacity.
8. The Rate of Setting.
9. The Foam Test.
10. The Grease Test.
11. The Reaction.
12. The Appearance, Odor, Color, Keeping Qualities, etc.

These will be considered in the order given above.

### 1. THE JELLY STRENGTH OR CONSISTENCY

In this country the jelly strength test is probably the most generally used test for the determination of what is called the *grade* of the glue. It is based upon the belief that if a number of glues are put into solution at a given concentration, and allowed to chill, or set, the value of the glues will, in general, be proportional to the relative consistency of the jellies so formed.

**The Early Methods of Making the Jelly Strength Test.**—A large number of *modi operandae* have been proposed for carrying out the technique of this test. In nearly all of them it is necessary to have some kind of a basis for comparison. In other words, the measurements obtained are not absolute, but are of value only in so far as they stipulate the relative consistency of one jelly as compared with another which is taken arbitrarily as a *standard*. By far the best known of these standards are those which were established by Peter Cooper in 1844. They consist of a series of eleven types of glue of a regularly varying jelly consistency, from the highest, which he calls A Extra to the lowest, which he calls No. 2. These are as follows:

A Extra	$1\frac{1}{2}$
1 Extra	$1\frac{5}{8}$
No. 1	$1\frac{3}{4}$
1 X	$1\frac{7}{8}$
$1\frac{1}{4}$	No. 2
$1\frac{3}{8}$	

Other American manufacturers have followed a somewhat similar system of grading, but, as they have developed under a regime of secrecy and intense competition, they have, for the most part, felt it incumbent upon themselves to mystify, rather than to make clear to the purchaser of their product the nature of the substance he is buying. Accordingly the present glue market is utterly submerged beneath a chaos of glue "grades," such as cx's, Bx's,

lx's, x3's, x4's and the like, which cannot possibly convey any intelligent meaning to the lay buyer. The action of Peter Cooper was a long step in the right direction, however, for his were the first lots of definitely graded glues, listed at definite market prices.

Inasmuch as the standards which are used for making all comparisons in jelly consistency are themselves glues which have been especially selected for that purpose, and as such standards must occasionally be renewed, it follows that these must vary from time to time, and as the order of jelly strength may be reversed at slightly different temperatures, and the same temperature is not always used for comparisons, it becomes evident that a system less arbitrary would be advantageous. This will be considered in Chap. X.

*The Finger Test.*—Of all the methods that have been suggested for making the test of jelly consistency, the oldest, and likewise the most persistent, is what is known as the finger test. Just when or how this test originated can not be ascertained. And, in spite of a score and more of newer and more scientific procedures, this ancient comparison has remained, even to the present, one of the most popular of the jelly strength tests. Fernbach<sup>1</sup> as late as 1907 wrote, "For practical commercial purposes, there is no better method of measuring the resistance of the glue jelly than by means of the finger. The fourth finger of the left hand is used, as it is the most sensitive of all." As the technique of most of the methods for measuring jelly consistency is the same except for the final operation, it will be given in detail at this place.

The glues are made up of such strength that, when chilled, the consistency will not be too great. Otherwise there will be difficulty in observing slight differences. For this reason it is not desirable to test all glues at the same concentration. If the inspection of the sample shows it to be a very weak glue, it may be made to about 15 per cent concentration. If it appears to be an unusually strong specimen 6 or 7 per cent will be satisfactory. For other intermediate glues 8, 10, and 12 per cent concentrations may be used.

The glues are carefully weighed out, such an amount being taken as will produce 200 c.c. of solution of the desired concentration. Standard glues which are expected to closely correspond

<sup>1</sup> R. L. FERNBACH, "Glues and Gelatine," New York (1907), 47.



in jelly consistency to the samples being tested are weighed out and treated exactly similarly to the latter throughout the procedure. The glues are placed in weighed glasses or tumblers, covered with cold water (any amount not exceeding the final necessary quantity may be added without measuring), and placed in a cool place, preferably in an ice box, for several hours, or over night. (If the glues are ground, an hour or two will suffice to soak them, but if in thick pieces they must stand for about eight hours.) After soaking, they are placed in a water bath in which the temperature of the water does not exceed 60°C. The glues are stirred frequently, allowed to reach a temperature of at least 50° and, when thoroughly dissolved, placed upon a balance and water added to make the necessary concentration. (The concentration is determined by the weight of glue taken, and the volume of solution always made the same, *e.g.*, about 200 c.c.) The glues are then again put in a cool place, which should be an ice box of a constant temperature of about 10°C., and allowed to remain for several hours, or over night. In making the test, the fingers (or one finger) are pressed lightly upon the surface of the glues being tested, and of the standards. If a given glue appears to offer the same resistance to the finger pressure that, for example, a standard 1½ glue (using the Cooper standards) offers, then the glue is given the grade 1½. If it offers a slightly greater resistance than the standard 1½, but less than the 1¾, it is graded as 1½+ or 1¾- depending upon which of the two it appears to be the nearest.

The finger test appears to have held its position of favor both on account of its simplicity of operation, requiring a minimum of apparatus, and also on account of the psychic "personal factor." The average man employed as a glue tester has an aversion to any appliance which seems to lessen his own responsibility and place the same upon a merely mechanical instrument. But it must be admitted that with practice a considerable amount of skill in testing by the fingers may be attained.

*Early Jelly-breaking Appliances.*—One of the earliest substitutes for the finger test was the device of Lipowitz.<sup>1</sup> He suggested a scheme which has been the basis of many modifications, and the principle of which is used quite extensively at the present time. He placed upon the surface of the jelly a flat disk, one or two inches in diameter, on the upper side of which was soldered

<sup>1</sup> LIPOWITZ, "Neue Chem. tech. Unters.," Berlin (1861), 37.

an iron rod supporting a funnel. The rod was held vertically over the jelly by being passed through a hole in a board which rested upon the glass tumbler. Lead shot was then slowly poured into the funnel until the weight was just sufficient to cause the thin disk to penetrate the surface of the jelly, or until the disk

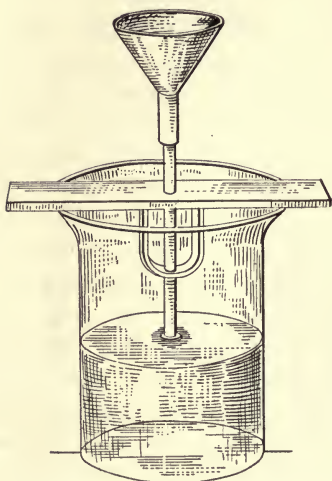

FIG. 64.—The Lipowitz jelly strength test.

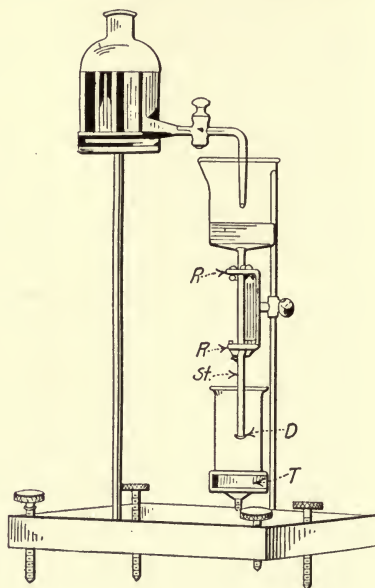

FIG. 65.—Valenta's apparatus for testing glue.

was caused to sink completely through the jelly and rest upon the bottom of the glass. The lead shot was then weighed, and this weight plus that of the funnel and tube taken as a measure of the jelly consistency. A sketch of the apparatus is shown in Fig. 64.

Another substitute for the finger test was suggested by Kissling.<sup>1</sup> He employed rods of glass, zinc, and brass of specified dimensions and weight, and measured the firmness of a jelly by noting the length of time taken by certain of these rods to penetrate and sink through the jelly. He compared the results obtained by his method with those of Stelling,<sup>2</sup> who rated glues according to their content of material insoluble in 72 per cent alcohol, and with those of Fels,<sup>3</sup> who graded glues according to

<sup>1</sup> R. KISSLING, *Chem. Ztg.*, **17** (1893), 726; **22** (1898), 171.

<sup>2</sup> C. STELLING, *ibid.*, **20** (1896), 461. See page 463.

<sup>3</sup> J. FELS, *ibid.*, **21** (1897), 56; **25** (1901), 23. See page 387-8.

their viscosity. He reported that the result of these comparisons was not satisfactory, although a certain parallelism was noticeable between the jelly-firmness and viscosity, and that Stellung's process showed that glues yielding the firmest jellies contained the smallest proportion of "non-glue."

Valenta<sup>1</sup> improved somewhat upon these earlier devices of Lipowitz and Kissling. Upon the jelly in a glass tumbler Valenta placed a convex piston, into the upper end of which was soldered a rod, held in a vertical position by means of a suitable frame. Upon the top of the rod was secured a beaker. Mercury was allowed to run slowly into the beaker until the combined weight of the piston, rod, beaker, and mercury was just sufficient to break through the surface of the jelly. This weight was taken as the measure of the jelly consistency, see Fig. 65.

An important modification of the Lipowitz instrument was invented by Scott<sup>2</sup> in 1907. Scott placed his beaker of jelly upon the pan of a spring balance, see Fig. 66, set the pointer at the zero mark, and slowly forced a rod, terminating in a conical metallic head, down until the surface of the jelly was broken. The pressure at this point was measured by the degree of deflection which was observed by the pointer of the scale.

**The Later Methods for Measuring Jelly Consistency.**—In most of the more recent methods for measuring jelly consistency some attempt has been made to overcome the error which always attends the breaking or compression of a jelly, due to the formation of a "skin," an especially tough layer, at the surface. This was early recognized by Alexander<sup>3</sup> who in 1906 suggested

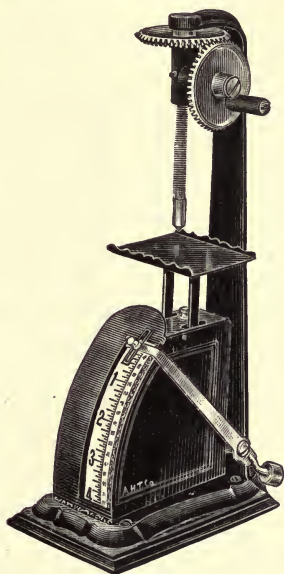

FIG. 66.—The Scott glue tester. (Kindness of The Arthur H. Thomas Company of Philadelphia.)

<sup>1</sup> VALENTA, *Chem. Ztg.*, **33** (1909), 94.

<sup>2</sup> SCOTT, *Chem. Eng.*, **5** (1907), 441.

<sup>3</sup> J. ALEXANDER, *J. Soc. Chem. Ind.*, **25** (1906), 158; U. S. Patent No. 882,731 (1908).

an ingenious instrument which permitted the free expansion of a block of jelly in one direction while being compressed in another direction. A sketch of the instrument is shown in Fig. 67. It consists essentially of a brass cylindrical vessel supported by four vertical rods against which it slides with roller bearings. This cup is allowed to rest upon a block of jelly, in the form of a

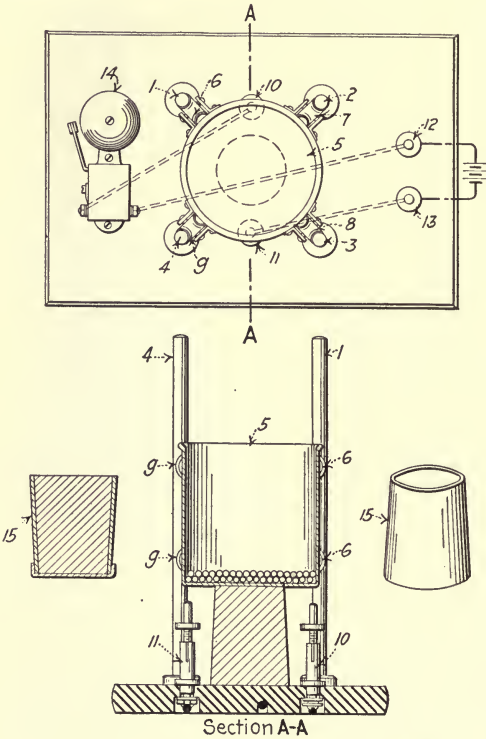

FIG. 67.—Alexander's jelly strength apparatus.

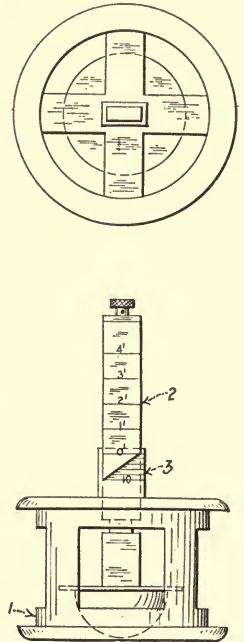

FIG. 68.—Jelly strength tester used by the Forest Products Laboratory.

truncated cone, of specified dimensions, concentration, and temperature. Lead shot is added slowly to the cup which causes the jelly to be compressed downward, while being free to expand outward. Electrical connections are installed in such a manner that when the cup has sunk downward a definite distance the circuit becomes automatically closed, and a bell rings. The combined weight of the cup and the shot gives a figure representative of the jelly consistency.



Sindall and Bacon<sup>1</sup> used a device not materially different in principle from the older methods except that an attempt was made to avoid the error due to the "skin" formation. They blew a bulb a half inch in diameter at one end of a short glass tube, placed this bulb upon the abraded surface of the jelly, and very slowly ran mercury into the bulb from a burette until the bulb was forced to a half inch from the bottom of the beaker.

An instrument which has been in use in the laboratories of the Armour Glue Works for a number of years, has been adopted, with a few slight modifications, by the United States Forest Service in their laboratory at Madison, Wisconsin, and has been described by them in their "Technical Notes."<sup>2</sup> It consists essentially of a light cylindrical frame of brass which is permitted to rest upon the surface of the jelly contained in a glass tumbler of specified dimensions. Moving vertically in the frame is a plunger, likewise of brass, and graduated upon the stem for a length of about four centimeters. The lower end consists of a blunt conical shaped head, which may be either solid, weighing about 325 grams, or hollow, in which case a definite mass of lead shot may be added so as to bring the weight to the most sensitive point for the particular jellies being tested. A set-screw is placed at the top so that the zero mark on the scale may be correctly adjusted after placing the whole apparatus upon a flat surface. A sketch of this instrument is shown in Fig. 68.

Perhaps the most conspicuous advantages of this instrument are (1) the great rapidity of manipulation, (2) the expression of the jelly consistency in terms of a numerical value, and (3) the reliability and duplicability of the readings obtained. The error due to skin formation is however not overcome.

In 1909 a patent was granted to E. S. Smith<sup>3</sup> for a glue-tester which differs materially from any hitherto proposed. A sketch is shown in Fig. 69. In principle, it measures the hydrostatic pressure necessary to force a rubber diaphragm downward into a jelly a stipulated amount. It consists of a thistle-tube containing water, the mouth of which is covered with a thin rubber diaphragm, and placed downward upon the surface of a jelly contained in a tumbler. It is connected by a T tube, on the one side, to a manometer gage containing mercury, and on the other

<sup>1</sup> SINDALL and BACON, *Analyst*, **39** (1914), 20.

<sup>2</sup> Forest Products, Lab. Technical Notes, No. **F 32** (1919).

<sup>3</sup> E. S. SMITH, U. S. Patent No. 911,277 (1909).

to a bulb by which pressure may be applied. On the stem of the thistle-tube is placed a graduated scale. In making the measurement the jelly is brought up against the rubber diaphragm until the water stands at the upper graduation mark, and both tubes opened to the air. The system is then closed, and pressure

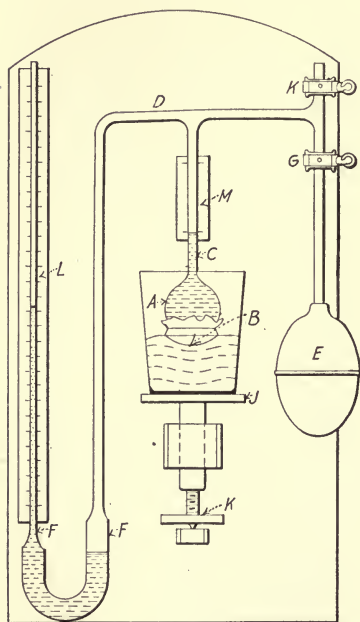

FIG. 69.—The apparatus of E. S. Smith for measuring jelly strength.

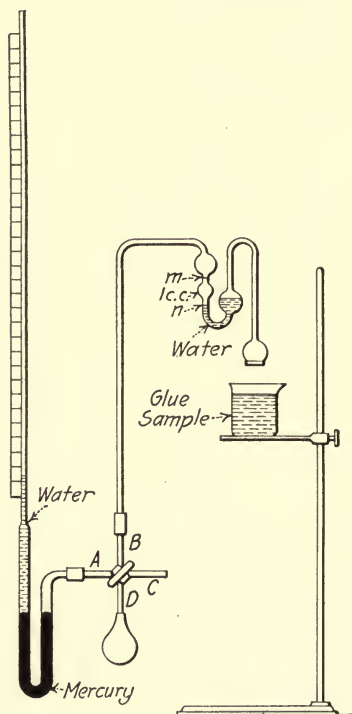

FIG. 70.—Hulbert's jelly strength apparatus.

applied by the bulb until the water in the thistle-tube has been forced down, by the displacement of the jelly, to the lower graduation mark, and the pressure simultaneously read on the manometer scale.

A modification of this instrument was suggested by Hulbert<sup>1</sup> in 1913.

His apparatus is shown in Fig. 70. It consists of a thistle-tube, the stem of which is twice bent, and contains three bulbs. The two larger serve as safety traps, and are of about 2 cm. in

<sup>1</sup> E. HULBERT, *J. Ind. Eng. Chem.*, 5 (1913), 235.

diameter. The smaller middle one is graduated to contain 1 c.c. A diaphragm of thin rubber is stretched over the mouth of the thistle-tube. A few c.c. of water are placed in the bulbs and the thistle-tube brought down upon a jelly until the water just reaches the upper mark in the graduated bulb. The further end of the tube is connected by a 4 way stop-cock to (1) the air, (2) a gage consisting of a U tube containing mercury and a long open

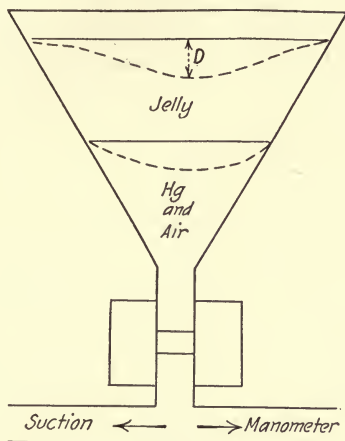

FIG. 71.—C. R. Smith's jelly strength test.

fine-bore tube containing water, and (3) a bulb by which air may be forced into the system. After opening both parts of the tube to the air, the stop-cock is turned to connect the manometer, the tube, and the bulb, and air is forced in until the water in the graduated bulb has dropped to the lower mark. The reading of the column of water in the manometer is now noted as the measure of the jelly consistency.

W. H. Low<sup>1</sup> has reported that, in the hands of a careful worker, the original apparatus of Smith, with a few minor modifications, is capable of giving concordent results, and is more suitable for general work than the modification of Hulbert.

An altogether different principle for measuring jelly consistency has been suggested by C. R. Smith,<sup>2</sup> and is shown in Fig. 71. A glass funnel 80 mm. across the top, with a short stem accurately formed at a 60° angle is used. One hundred and twenty grams of

<sup>1</sup> W. H. LOW, *J. Ind. Eng. Chem.*, **12** (1920), 355.

<sup>2</sup> C. R. SMITH, *ibid.*, **12** (1920), 878.

mercury are poured into the funnel, which is closed at the end, giving a surface diameter of 3 cm. to the mercury. Fifty c.c. of the gelatin or glue solution are then poured over the mercury, and allowed to solidify at 10°C., care being taken to maintain the funnel in a perfectly vertical position. The mercury is then drawn off, and suction applied to the tube of the funnel to the extent of 6 dm. of water, measured by a manometer. A depression in the jelly is produced which is measured by a micrometer depth gage to a thousandth of an inch. Smith has succeeded in obtaining some remarkably suggestive results by the use of this simple appliance.

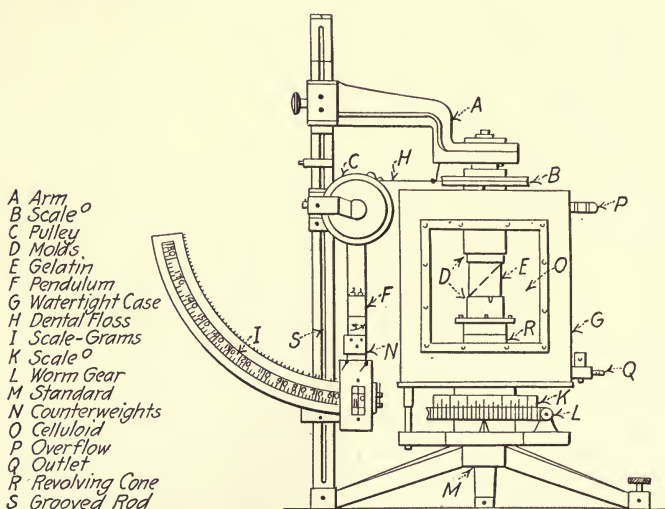

FIG. 72.—Sheppard's jelly strength testing machine.

The only instrument that has been devised for measuring jelly consistency that may be regarded as truly scientific, and capable of producing results that are not only relative but are absolute, is the ingenious apparatus developed by S. E. Sheppard and his collaborators<sup>1</sup> at the laboratories of the Eastman Kodak Company. They report that "in seeking for correlation between viscosity coefficients and elasticity coefficients or moduli, it is desirable that the elastic values, *e.g.*, limit of elasticity and tensile strength, should be obtained for pure shear. This condition is secured by submitting cylinders of the material to be tested (the jelly) to

<sup>1</sup> SHEPPARD, SWEET and SCOTT, *J. Ind. Eng. Chem.*, **12** (1920), 1007; *J. Am. Chem. Soc.*, **43** (1921), 539.



torsional stress." A sketch of the instrument is shown in Fig. 72, and is self explanatory.

The gelatin or glue is cast in a cylindrical mold having a split jacket, which is removed after the cylinder has been fixed in position in the instrument. The grips are inserted as a part of the mold. The gelatin solution is poured in at a temperature of 40°C., and allowed to chill for 3 hours at zero degrees. The entire mold is then placed in the instrument, the grips clamped in, the sides of the mold removed, the scales all set at zero, and the base of the cylinder rotated at a constant speed. The upper part of the cylinder is also free to rotate, but this upper rotation is opposed by a weight, in the form of a weighted arm moving in an arc, causing a constantly increasing weight for each increment of rotation of the upper end of the cylinder. At the point where the cylinder of jelly breaks, the reading on this arc is taken as the breaking load, and the difference between the rotation of the lower and the upper ends of the cylinder, measured by two scales, is the torsional "twist" which the jelly has sustained. The break should be in the form of a hectical cleavage, at a 45° angle, extending from the base to the upper end of the column, with no sign of imperfect adhesion. If the break is imperfect the test should be rejected. For investigational purposes it seems desirable to use the expression

$$\frac{\text{Breaking load} \times \text{per cent twist}}{\text{Cross-section area}}$$

as the measure of the jelly strength, rather than the breaking load alone.

Oakes<sup>1</sup> has recently described the Schweizer jelly testing apparatus of the United Chemical and Organic Products Co., of Chicago. This is somewhat similar to the Scott apparatus previously described. It consists, as shown in the accompanying photograph, of a balance, in one pan of which is placed an empty beaker, and to the bottom of which is soldered a blunt plunger. These are counterpoised so that the pointer rests at zero. The jelly in a tumbler is brought into contact with the plunger, and water then allowed to run at a constant slow rate into the beaker until the pointer has reached an arbitrarily fixed deflection, when, by an electrical contact, a light or bell announces the selected deflection.

<sup>1</sup> E. T. OAKES, 62nd Meeting, *Am. Chem. Soc.*, N. Y., Sept. 6-10, 1921.

## 2. THE VISCOSITY

A very large number of instruments have been described for the measurement of viscosity, but for use with solutions of gelatin and glue only a few of these are applicable. They may be divided into two groups: (1) those that measure the viscosity

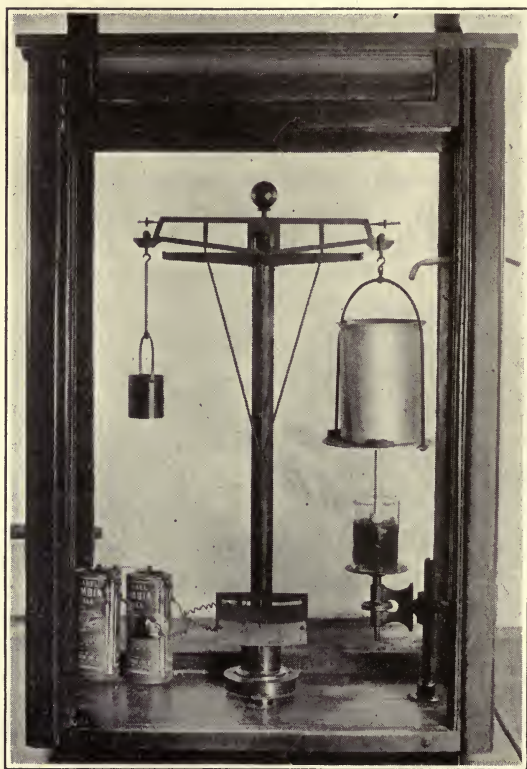

FIG. 73.—The Schweizer jelly testing apparatus.

by permitting a given amount of the liquid to flow through a capillary tube of stated dimensions, and (2) those in which the viscosity is measured by the resistance offered by the gelatin or glue to the movement within it of a disk, a cylinder, or a sphere.

The type of instrument which is used in any given case will depend upon the fluidity of the solutions which are to be measured, and upon the degree of accuracy which it is desired to attain. For highly accurate work upon very dilute solutions, the Ostwald or Bingham tubes are most satisfactory; for more

concentrated solutions the Couette instrument and the rolling sphere device of Flowers, have given good results. Where rapidity of operation is necessary, and only approximate results are desired, the various modifications of the pipette have been most widely used, but the MacMichael viscosimeter has been found to be very satisfactory. A few of the more important types of viscosimeter are described below, following the development of the laws pertaining to the resistance of fluid motion.

**The Theory of Viscous Flow.**—The first laws defining the resistance of liquid flow, which were based upon careful experimentation, were developed by Coulomb<sup>1</sup> in 1784. He employed a cylinder, and later a disk, oscillating in the liquid, and suspended by a fine wire, and showed that the resistance of a liquid to a body moving in it was proportional to the surface area of the body and the velocity of the latter. He further showed that fluid resistance consisted of two components: internal friction and inertia. The resistance due to inertia was pointed out to be proportional to the density. This resulted in the mathematical expression:<sup>2</sup>

$$R_2 = K_2 \gamma V^2,$$

where  $R_2$  is the total resistance offered,  $K_2$  is a constant,  $\gamma$  the density of the liquid, and  $V$  the velocity.

Poiseuille,<sup>3</sup> in a series of classic experiments upon the flow of liquids through capillary tubes, demonstrated that the flow of liquid varied directly as the pressure, directly as the time, directly as the fourth power of the diameter of the capillary, and inversely as the length of the capillary, or

$$Q = K \frac{p t d^4}{L},$$

where  $Q$  is the outflow in cubic centimeters;  $K$ , a constant;  $p$ , the pressure in dynes per sq. cm.;  $t$ , the time of outflow in seconds;  $d$ , the diameter of the capillary in centimeters; and  $L$ , the length of the capillary in centimeters.

The value of  $K$  may be calculated by applying the equations of Coulomb, which give, according to Brillouin:<sup>4</sup>

<sup>1</sup> COULOMB, *Historie de l'Academie, Soc. Francaise Phys.* (1784).

<sup>2</sup> Cited from Flowers, *Proc. Am. Soc. for Test. Mat.*, **14** (1914), 565.

<sup>3</sup> POISEUILLE, *Acad. Sci. Rec. Sav. Etrangers* (1842-1846).

<sup>4</sup> BRILLOUIN, "Viscosite des Liquides et des Gaz.," Paris (1970), vol. 1, p. 56-135.

$$Q = \frac{\pi}{128\eta} \frac{p d^4}{L},$$

where  $\pi = 3.14159$ , and  $\eta$  is the viscosity of the liquid.

By further applying the corrections of Couette<sup>1</sup> for the end effects due to acceleration, and of Brillouin for the resistance due to the converging stream lines at the entrance to the capillary, the following equation for viscosity is obtained:

$$\eta = \frac{\pi p d^4 - \frac{16\gamma Q^2}{t^2}}{128\pi \left(L + \frac{d}{16}\right) \frac{Q}{t}}.$$

In 1851 Stokes<sup>2</sup> developed the law which bears his name, which defines the relations between the velocity and resistance to the movement of a sphere falling through a viscous fluid. His equation is written:

$$V = \frac{1}{18} \frac{d^2 g}{\eta} (\gamma_s - \gamma_m),$$

where  $V$  is the limiting velocity;  $d$  the diameter of the sphere in centimeters;  $g$  the acceleration of gravity in dynes;  $\eta$  the absolute viscosity in dynes;  $\gamma_s$  the density of the sphere in grams per c.c.; and  $\gamma_m$  the density of the medium in grams per c.c.

Reynolds<sup>3</sup> has shown that Poiseuille's law which states that the outflow of liquid through a capillary tube varies directly as the pressure, was applicable only for a certain range of pressures. If the pressure applied is gradually increased, a point will be reached where the flow quite suddenly becomes turbulent and filled with eddies. As the pressure is increased above this point, still another critical point is eventually reached above which the flow is again regular, but the increase in flow with increase in pressure is less than it is below the first appearance of turbulent flow. At pressures between the two critical points the variation in outflow with pressure is irregular: The critical velocity at which turbulence begins is given by the equation:

<sup>1</sup> COUETTE, *Ann. Chem. et Phys.*, **6** (1890), 21; 502.

<sup>2</sup> STOKES, *Mathematical and Physical papers, Cambridge, Univ.*, **3** (1880), 55.

<sup>3</sup> REYNOLDS, *Trans. Royal Soc., London*, **174** (1883), 935; **186** A (1895), 123.



$$V_s = 2,000 \frac{\eta}{\gamma d}, \text{ or } \frac{V_s \eta}{\gamma d} = 2,000,$$

where  $V_s$  is the velocity in meters per second;  $\eta$ , the absolute viscosity in dynes;  $\gamma$ , the density in grams per c.c.; and  $d$ , the diameter of the tube in centimeters. The value  $\frac{V_s \eta}{\gamma d}$  is known as Reynolds' criterion. It has been shown however by Flowers<sup>1</sup> and by Hayes and Lewis<sup>2</sup> that the value 2,000 is too high for short tube viscosimeters, and that the flow of water at 20°C. through the tubes of technical viscosimeters, as the Engler, Saybolt, and Redwood type, is such that the critical velocity is exceeded, and turbulent flow results. It becomes necessary, therefore, in using these instruments, or others of the short capillary type, that some material more viscous than water must be used for standardization, and that only relatively viscous liquids may be accurately determined by them.

Bingham<sup>3</sup> states the most generally accepted formula for the viscous flow of a liquid through a capillary of uniform circular cross-section to be:

$$\eta = \frac{\pi g r^4 p t}{8v(l + \lambda)} - \frac{m n \rho v}{8\pi t(l + \lambda)},$$

in which  $\eta$  = the viscosity in absolute c.g.s. units;

$\pi$  = 3.1416;

$g$  = the gravitation constant of the locality;

$r$  = the radius of the capillary in centimeters;

$p$  = the pressure in grams per sq. cm.;

$t$  = the time in seconds;

$v$  = the volume in cubic centimeters;

$l$  = the length of the capillary in centimeters;

$\lambda$  = the correction to capillary length for "end effect,"

$m$  = a coefficient, probably 1.12;

$n$  = the number of capillaries in use; and

$\rho$  = the density of the liquid.

Deeley and Parr<sup>4</sup> and Herschel<sup>5</sup> have suggested that the

<sup>1</sup> FLOWERS, *loc. cit.*

<sup>2</sup> HAYES and LEWIS, *J. Am. Soc. Mech. Eng.*, **38** (1916), 629.

<sup>3</sup> E. C. BINGHAM, *Proc Am. Soc. for Test. Mat.*, **18** (1918), 373.

<sup>4</sup> DEELEY and PARR, *Phil. Mag.*, **26** (1913), 87.

<sup>5</sup> W. H. HERSCHEL, U. S. Bureau of Standards, *Tech. Paper*, No. **112** (1918).

absolute viscosity in c.g.s. units be designated by the term *poise*, and that this viscosity divided by the density be known as the *kinematic viscosity*. Herschel has further shown that the equation of Bingham given above may be reduced, for all viscosimeters of the capillary tube type, to the general form:

$$\frac{\mu}{\gamma} = At - \frac{B}{t},$$

in which  $\mu$  is the viscosity in poises;  $\gamma$  the density in grams per c.c.;  $t$ , the time of discharge in seconds; and  $A$  and  $B$  are instrumental constants which may be found either by theory or experiment. The values of these constants which have been reported by Herschel for different instruments are as follows:

	A	B
Saybolt.....	0.00220	1.80
Engler.....	0.00147	3.74
Redwood.....	0.00260	1.561

**The Capillary Tube Type of Viscosimeter.** *The Saybolt, Engler and Redwood Instruments.*—The saybolt, Engler, and Redwood viscosimeters are three technical instruments of very much the same type which were developed in the United States, Germany, and England, respectively, at about the same time, and before the relations of viscous flow had been thoroughly developed mathematically and understood. In consequence they are not altogether scientific in their design. They consist, as shown in the accompanying illustrations, of a reservoir in which the liquid to be tested is placed, enclosed in a water or oil bath for maintaining a definite temperature. From the center of the reservoir a short capillary tube about 2 cm. in length permits the outflow of the liquid. The water bath of the Engler and Redwood instruments is inadequate and requires frequent attention in maintaining a constant temperature. When duplicate determinations are desired, the process becomes very time-consuming, for the liquid must again be heated to the necessary temperature before running through. It is not easy to clean thoroughly the capillary tubes in the Engler and Redwood instruments, on account of their shape and position.

There has appeared a considerable amount of opposition to the several types of commercial viscosimeter, which has been based for the most part upon theoretical considerations that have shown the unreliability of those instruments as the means of

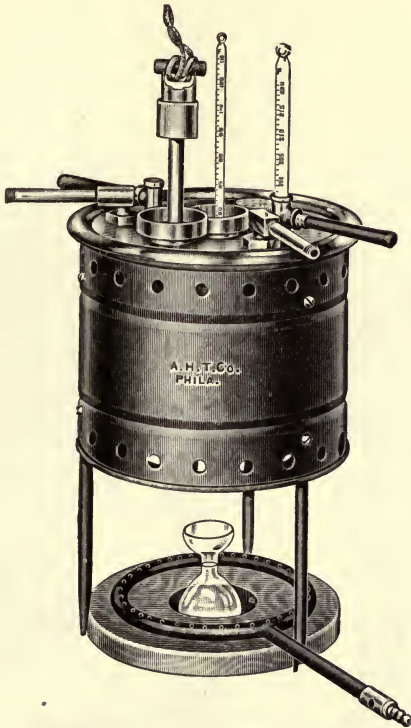

FIG. 74.—The Saybolt universal viscosimeter. (Kindness of The Arthur H. Thomas Company of Philadelphia.)

measuring actual viscosity. Among the objections raised by Bingham<sup>1</sup> are the following:

1. The formula is valid only when the velocity is below the Reynolds' criterion.

2. Since the capillary is very short—2.0 cm.—the end correction is appreciable and variable.

3. The time of outflow is not strictly proportional to the viscosity alone, but varies inversely as the density, so that the common practice of expressing viscosity as seconds of outflow is incorrect and misleading. This applies to glue and gelatin

<sup>1</sup> E. C. BINGHAM, *loc. cit.*

measurements as well as to any other commercial substance. Not only to avoid confusion, but for the sake of accuracy, the viscosity should be expressed in absolute units, or poises.

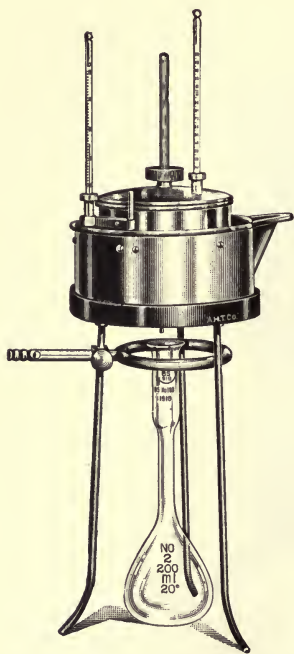

FIG. 75.—The Engler viscosimeter.  
(Kindness of The Arthur H. Thomas  
Company of Philadelphia.)

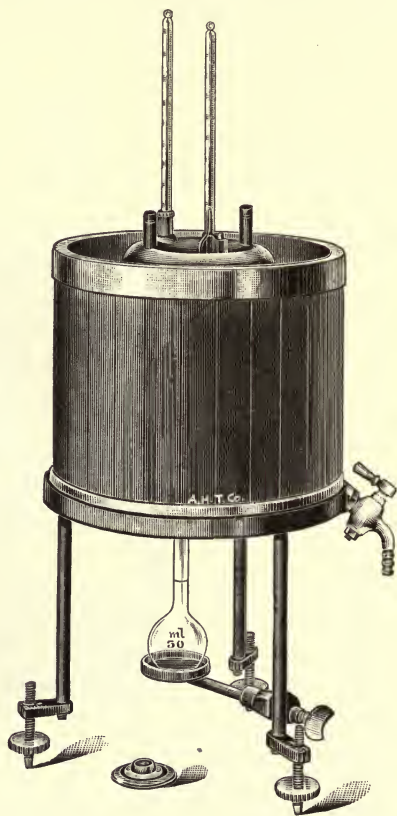

FIG. 76.—The Redwood viscosimeter.  
(Kindness of The Arthur H. Thomas  
Company of Philadelphia.)

4. In very viscous liquids the outflow, especially near the end of the operation, may be in the form of drops instead of a steady stream. This drop formation results in a surface tension effect which tends strongly to repress the flow.

5. The instruments lack a proper temperature control. The bath is small and inadequate, and the volume of liquid large so that it takes much time for it to reach the proper temperature, and it is difficult to maintain the correct temperature throughout. Duplicate determinations are very time-consuming, as the



chilled liquid must be again heated before another run can be made.

6. The variation in pressure obtainable is small while the variation in viscosity may be very large.

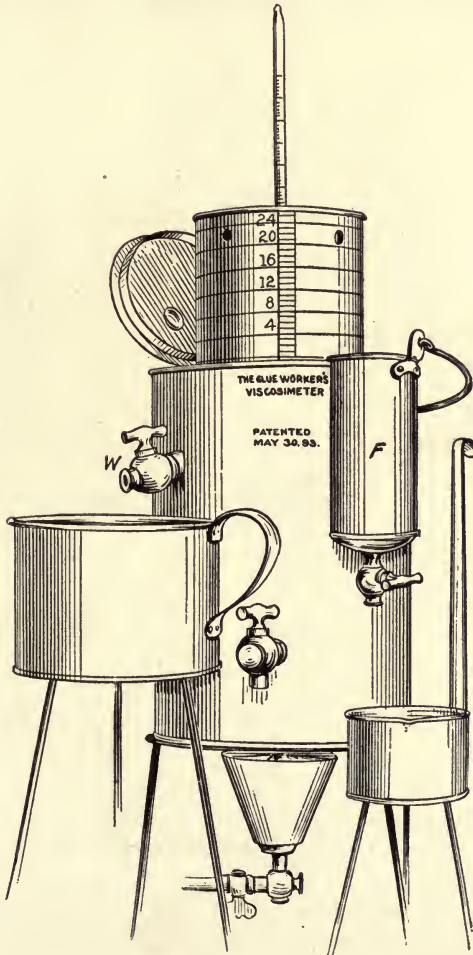

FIG. 77.—Kahrs' viscosimeter glue pot.

*The Pipette Viscosimeters.*—Most of the viscosimeters that have been proposed for use by the glue trade are of the short capillary tube type. Fels<sup>1</sup> in 1897 proposed that the Engler instrument

<sup>1</sup> J. FELS, *Chem. Ztg.*, **21** (1897), 56; **25** (1901), 23.

be adopted as a standard for glue evaluation in Germany. He first employed a temperature of 30° but in 1901 raised it to 35°C. In 1905 Kahrs<sup>1</sup> suggested a crude combination instrument by which could be measured the time of outflow, through a small stop cock, of about 9 oz. of glue solution. From 30 to 60 seconds

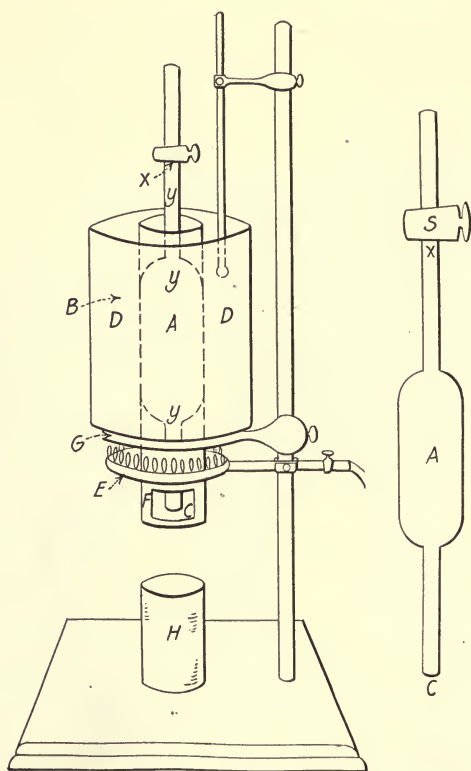

FIG. 78.—Fernbach's viscosimeter. (From Fernbach's "Glues and Gelatine," D. Van Nostrand Co., New York, 1907.)

sufficed for the measurement. In 1906 Fernbach<sup>2</sup> proposed the use of an ordinary 50 c.c. pipette which could be enclosed in a water bath if desired. Alexander,<sup>3</sup> in the same year, suggested a very similar instrument, but urged that the dimensions should be carefully specified in order that "standard" readings might be

<sup>1</sup> F. KAHRs, "Glue Handling," East Haddan, Conn. (1905-6), 58.

<sup>2</sup> FERNBACH, "Glues and Gelatin," New York (1906), 38.

<sup>3</sup> J. ALEXANDER, *J. Soc. Chem. Ind.*, **25** (1906), 158.

obtained. The United States Forest Service<sup>1</sup> has recommended the Engler instrument as recently as 1920.

It will be immediately obvious that the objections which have been enumerated for the Saybolt, Engler, and Redwood instruments upon theoretical grounds apply also, and to a multiplied

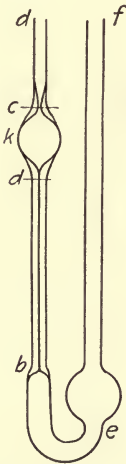

FIG. 79.—The Ostwald viscosimeter.

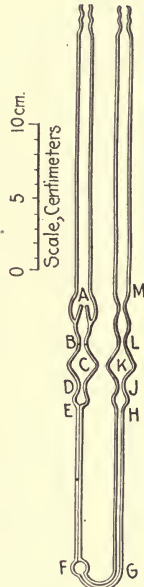

FIG. 80.—The Bingham viscosimeter.

degree, to the pipette types mentioned above. But of even greater moment, as it applies to the glue trade—the manufacturers, jobbers, and users of glue and gelatin—must be mentioned the impossibility of a uniform expression for viscosity, intelligible to everyone, so long as the present system prevails, of each tester making his viscosity measurements with tubes of his own specifications. Most of the glue trade employ a pipette type of instrument; but the dimensions, the volume of outflow, and the method of expressing the results, are almost as diverse as the number of companies or individuals who make the test. Some one standard instrument should by all means be employed, and the viscosity expressed always in absolute units.

*The Ostwald and Bingham Viscosimeters.*—Most of the objections that have been raised against the use of the short capillary

<sup>1</sup> National Advisory Committee for Aeronautics, *Report 66* (1920), 26.

tube type of viscosimeter are eliminated, *in the case of not too viscous liquids*, in the simple classic instrument of Wm. Ostwald,<sup>1</sup> shown in Fig. 79. This consists of a tube, one side of which is about 10 mm. in diameter. The other side consists of a

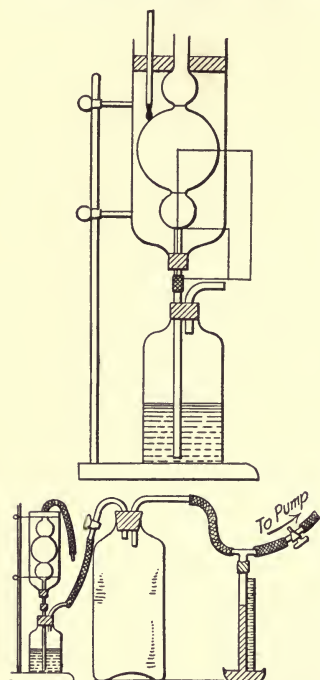

FIG. 81.—The Rideal-Slotte viscosimeter.

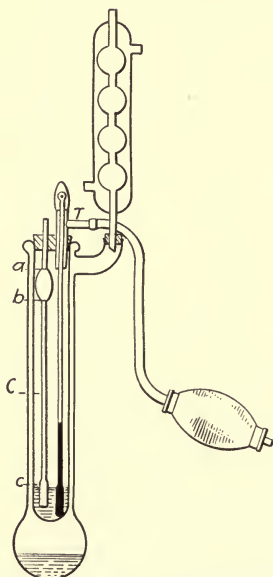

FIG. 82.—The viscosimeter of Baumé and Vigneron.

capillary tube about 8 cm. in length at either end of which is blown a bulb. The upper bulb holds about 2 c.c., and a graduation mark is placed on a capillary tube just above and below this bulb. In making the measurement, the tube is immersed in a constant temperature bath, about 3 c.c. of liquid which has reached the desired temperature is pipetted into the wide tube and, by applying suction, this is drawn up through the capillary tube until the upper bulb is filled, and the liquid has passed the upper graduation mark. The suction is then released and, by the use of a stop-watch, the time noted between the passing

<sup>1</sup> WM. OSTWALD, "Physico-Chemical Measurements," translated by Walker, 1894. See also FINDLAY "Practical Physical Chemistry" (1911), 72.



of the liquid from the upper to the lower graduation mark. For more accurately recording the time of outflow of this instrument, Rankin and Taylor<sup>1</sup> have modified the instrument by the attachment of connections to an electromagnetic clock which automatically records the time.

Bingham<sup>2</sup> has further improved upon the Ostwald model by devising an instrument such that, by applying pressure to either side, the measurements may be repeated, under varying pressure control, at will, see Fig. 80.

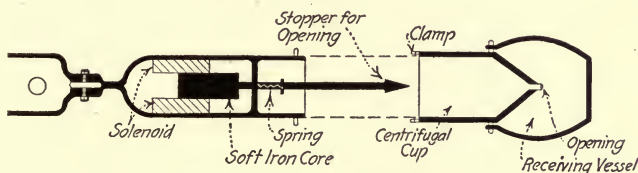

FIG. 83.—Cope's centrifugal viscosimeter.

Rideal<sup>3</sup> employed a capillary tube above which was sealed a larger tube having three bulbs blown in it as shown in the diagram. These were surrounded with a water jacket. The glue solution which was of 1 per cent concentration at 20°C. was drawn up into the upper bulb and allowed to run out slowly, by placing the finger lightly at the upper opening of the tube, until the level had reached the constriction between the upper and middle bulbs. The finger was then removed and the time taken for the solution to run out to the lower constriction of the middle bulb measured by a stop watch. In case the liquid was very viscous the time could be shortened by applying a definite reduction of pressure to the lower end of the tube as shown, and subsequently correcting for this reduced pressure.

Baumé and Vigneron<sup>4</sup> have suggested an instrument (see Fig. 82) by which any form of viscosimeter tube of the capillary type is immersed at one end of the liquid under examination. This is surrounded by a thermostatic jacket in which a liquid of a constant boiling point is kept boiling. After allowing 15 minutes for the contents to reach a constant temperature, the solution is

<sup>1</sup> RANKIN and TAYLOR, *Trans. Roy. Soc. Edinburg*, **45** (1905-7), 397.

<sup>2</sup> E. C. BINGHAM, *loc. cit.*

<sup>3</sup> S. RIDEAL and W. YOULE, *J. Soc. Chem. Ind.*, **10** (1891), 615; S. RIDEAL, "Glues and Glue Testing" (1901), 130.

<sup>4</sup> BAUMÉ and VIGNERON, *Ann. Chim. anal. appl.*, **1** (1919), 379.

forced up into the viscosimeter tube by compressing the bulb connected at *T*. The time in seconds taken by the solution in falling between two points, *a* and *b*, marked off on the tube is taken as the viscosity.

Cope<sup>1</sup> has suggested a device by which a centrifugal force may be applied to the liquid, and varied at will. This gives a constant pressure upon the liquid, and by an electromagnetic arrangement the outlet to the capillary may be opened or closed while the centrifuge is in operation, thus permitting of an accurate control of the time allowed for a given test. The weight of liquid transpiring in the given time and at the given pressure, is used as the measure of viscosity, see Fig. 83.

**The Rising Bubble and Falling Sphere Types of Viscosimeter.** *The "Bubble" Method.*—A method known as the *bubble method* for the determination of relative viscosities has occasionally been used. C. R. Smith<sup>2</sup> used a bubble of air about 4.5 mm. in diameter admitted at the bottom of a polariscope tube, and noted the rate of ascent. Faust,<sup>3</sup> in a study of this method, reported that the time of ascent of a bubble of air was independent of its size, but that the tube must be not less than 18 to 24 mm. in diameter in order that the calculated and experimental results should be in harmony.

*The Falling Sphere Method.*—The basis of the measurement of viscosity, by noting the velocity of fall of a sphere through a liquid, was established by Stokes<sup>4</sup> more than seventy years ago, but the application of this principle to commercial practice has developed only recently. In 1907 Ladenburg<sup>5</sup> suggested the first practicable application, and carefully defined the conditions and the constants involved. Ladenburg's work was followed shortly by a treatise by Arnold<sup>6</sup> upon the same subject. In 1917 Sheppard<sup>7</sup> made use of this method for the determination of the viscosity of very viscous solutions of nitrocellulose, and more recently has used it with gelatin sols. He employed for the purpose steel ball bearings of  $\frac{1}{4}$ ,  $\frac{3}{8}$  and  $\frac{1}{2}$  inch diameter and permitted them to drop axially into the center of a tube contain-

<sup>1</sup> W. C. COPE, *J. Ind. Eng. Chem.*, **9** (1917), 1046.

<sup>2</sup> C. R. SMITH, *J. Am. Chem. Soc.*, **41** (1919), 135.

<sup>3</sup> O. FAUST, *Z. physik. Chem.*, **93** (1919), 758.

<sup>4</sup> STOKES, *op. cit.*

<sup>5</sup> R. LADENBURG, *Ann. physik.*, **22** (1907), 287; **23** (1907), 447.

<sup>6</sup> H. D. ARNOLD, *Phil. Mag.*, **22** (1911), 755.

<sup>7</sup> S. E. SHEPPARD, *J. Ind. Eng. Chem.*, **9** (1917), 523.

ing the liquid, 40 cm. in height, standing in a water bath maintained at 20°C. The time occupied by the sphere in passing from one graduation mark on the cylinder to another lower down was noted by a stop-watch, and the absolute viscosity calculated by Stocks' law. This held sufficiently closely for industrial purposes provided the ratio of the diameters of the tube to the ball was at least 10.

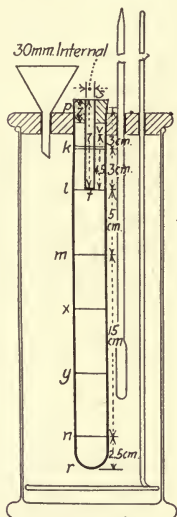

FIG. 84.—The Gibson-Jacobs falling sphere viscosimeter.

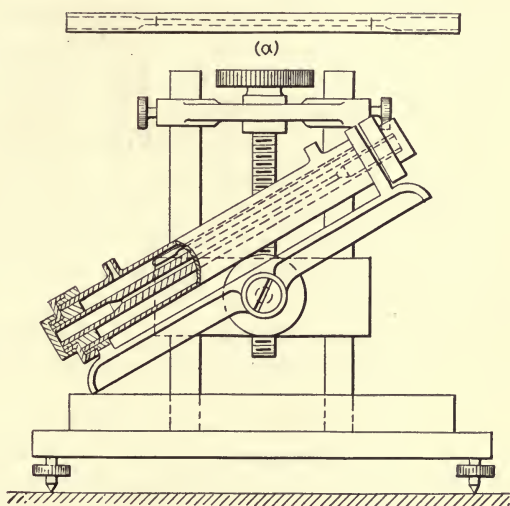

FIG. 85.—Flowers' rolling sphere viscosimeter.

Gibson and Jacobs<sup>1</sup> have used the same method also upon solutions of nitrocellulose, but the equations which they have developed differ from those of Sheppard. They contend that the diameter of the sphere should be much smaller than those used by Sheppard, and recommend a size of 0.15 centimeter in diameter. They used a tube (Fig. 84) 29 cm. in height and 2 cm. in diameter. The measurements were made in the same manner as those of Sheppard, but a different form of release for the sphere is suggested.

Fischer<sup>2</sup> has applied this method to the determination of the viscosity of glues.

<sup>1</sup> GIBSON and JACOBS, *J. Chem. Soc.*, **117** (1920), 473.

<sup>2</sup> R. FISCHER, *Chem. Ztg.*, **44** (1920), 622.

*The Rolling Sphere Method.*—Flowers<sup>1</sup> has conceived of a new method for measuring viscosity by rolling a sphere down an inclined tube filled with the liquid under examination. Spheres of different density, as normal Jena glass, hard steel, and platinum, were used depending upon the relative density and viscosity of the liquid. He finds that "the resistance may be very great indeed, if the sphere nearly fills the tube bore; that it decreases at first very rapidly as the bore of the tube is increased, and then more slowly. It is shown that for a given ratio of diameters of sphere and bore of tube, the velocity attained increases more rapidly than the sine of the slope angle of the slanted tube, but the rate of change of velocity is the same for all viscosities above a certain minimum value, and that at any given slope the time to roll a given distance increases directly with the viscosity. He finds the rolling sphere type of viscosimeter entirely practicable for commercial purposes, and that it may be used for the comparison of absolute viscosity over a wide range with a moderate error.

Flowers found that the absolute viscosity could very easily be calculated by the simple equation:

$$\eta = KK_2t,$$

where  $\eta$  is the absolute viscosity in dynes;  $K$  a constant dependent upon the diameters of the sphere and the tube, the slope, and the roll distance;  $K_2$ , the correcting factor due to the density of the liquid tested; and  $t$ , the time of roll in seconds.

**The Torsional Type of Viscosimeter.** *Oscillating Cylinder or Disk Viscosimeter.*—In 1893 Doolittle<sup>2</sup> revived a modification of the instrument employed by Coulomb in 1784. A hollow cylinder was suspended by a wire, about 8 inches in length, into the liquid to be tested, which was contained in a brass cup. By means of a suitable device this cylinder was rotated one complete revolution of 360°, and released. Due to the torque on the wire, the cylinder would revolve back to the zero point and continue in the opposite direction a certain distance which was dependent upon the viscosity of the liquid. Several oscillations were permitted, and the average difference between succeeding turns taken as a measure of the viscosity. Garrett,<sup>3</sup> in 1903,

<sup>1</sup> A. E. FLOWERS, *Proc. Am. Soc. for Test. Mat.*, **14** (1914), 565.

<sup>2</sup> DOOLITTLE, *J. Am. Chem. Soc.*, **15** (1893), 173.

<sup>3</sup> GARRETT, *Phil. Mag.* (6), **6** (1903), 374.



used a similar device for determining the viscosity of gelatin solutions, but employed a disk instead of a hollow cylinder, submerged in the liquid.

*The Couette Viscosimeter.*—The Couette, Stormer, and the MacMichael viscosimeters may be regarded as special modifications of these older oscillating types, but they differ from the latter in that the shear is a constant one, dependent upon a rotation of the liquid, rather than one of oscillation.

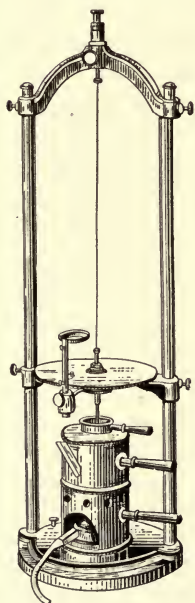

FIG. 86. — The Doolittle torsion viscosimeter.

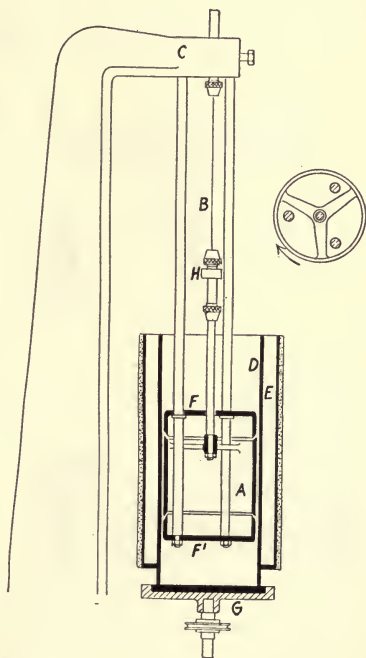

FIG. 87.—Hatschek's modification of the Couette viscosimeter.

The Couette instrument<sup>1</sup> consists of a hollow cylinder suspended by a fine wire into a slightly larger one, coaxial to it, in which is placed the liquid to be tested. The outer cylinder is provided with a water jacket. This outer cylinder with its water jacket is caused to revolve at any desired speed, and the deflection of the suspended cylinder, which soon becomes constant, is noted. Hatschek<sup>2</sup> has improved the original design

<sup>1</sup> COUETTE, *J. phys.*, **9** (1890), 414; *Ann. Chem. Phys.*, **6** (1890), 21; 502.

<sup>2</sup> E. HATSHECK, *Trans. Faraday Soc.*, **9** (1913), 80.

of the instrument, see Fig. 87, and made it adaptable for highly accurate measurements. He uses the product of the deflection times seconds per revolution, as the viscosity, and reports highly satisfactory results. It should be pointed out that in this apparatus the clearance between the suspended and the rotating cylinder is very slight, and that the velocity of rotation is very low, *e.g.*, from 3 to 96 seconds being taken for one revolution. In these respects it differs greatly from the MacMichael instrument.

*The Stormer Viscosimeter.*—The Stormer viscosimeter, Fig. 88,

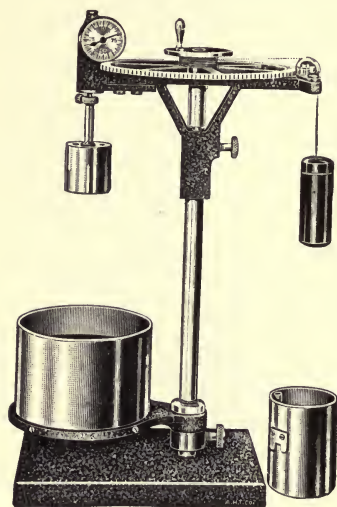

FIG. 88.—The Stormer viscosimeter. (Kindness of The Arthur H. Thomas Company of Philadelphia.)

is an instrument in which a cylinder is caused to rotate in the liquid under examination through the influence of a weight. As the rotation of the cylinder under the influence of any given weight is assumed to be proportional to the viscosity of the liquid, the time in seconds taken for 100 revolutions of the cylinder is taken as the measure of viscosity. If water is taken as unity then the quotient obtained by dividing the time taken in any given liquid by the time taken in water gives the relative viscosity in terms of water. For very viscous liquids a heavier weight is used, and

the viscosity of some "intermediate" liquid used for calculating back to water.

Rogers and Sabin<sup>1</sup> have recommended the Stormer instrument as being especially well adapted for the comparison of the viscosities of paints, but Rigg and Carpenter<sup>2</sup> have pointed out several sources of probable error in its use. First, the friction of the instrument must be measured and a correction applied. This may vary from day to day. Second, in order to secure comparable figures for different liquids, a constant weight must

<sup>1</sup> A. ROGERS and A. SABIN, *J. Ind. Eng. Chem.*, **3** (1911), 737.

<sup>2</sup> G. RIGG and J. CARPENTER, *ibid.*, **4** (1912), 901.

be used. Third, the use of the "intermediate" liquid may result in an error of over 20 per cent. They deprecate the use of the instrument except within the narrow limits where only one weight shall be used throughout.

Higgins and Pitman<sup>1</sup> have recently applied the Stormer instrument to the measurement of the viscosity of pyroxylin solutions with apparant success. They compared several types and concluded that the Stormer was the most suitable. Viscosities ranging from 10 times that of water to 200 times that of castor oil at 20°C. were measured with no difficulty. They find that the general equation expressing absolute viscosity is of the type:

$$V = At + B,$$

where  $V$  is the viscosity in centipoises;  $A$  and  $B$  are instrumental constants, which in this case vary as the weight used; and  $t$ , the corrected time for 100 revolutions.  $B$  is the value of  $V$  when  $t = 0$ , and  $A = \frac{V - B}{t}$ . The following equations with the values for  $A$  and  $B$  inserted were found for the different weights used:

$$\begin{aligned} 150 \text{ gram counterweight, } V &= 4.6t - 25, \\ 300 \text{ gram counterweight, } V &= 9.3t - 30. \end{aligned}$$

At values of  $V$  less than 15 the formula is not linear and does not hold. Above 15 it is linear.

*The MacMichael Viscosimeter.*—The MacMichael torsional viscosimeter,<sup>2</sup> Fig. 89, is the most recent of the series, having been first described in 1915. It consists of a brass disk, suspended by a fine gold-plated steel wire, into a brass cup which contains the liquid under examination. The cup is caused to revolve at a constant speed by a motor, and the friction of the liquid causes the suspended disk also to rotate until the torsional force in the suspending wire just balances the viscous resistance, and then it remains in a fixed position. The degree of deflection may be read by means of a dial which is divided into 300° to the circle. These are known as MacMichael degrees, or degrees M. The wires for use with the instrument are about 10

<sup>1</sup> E. HIGGINS and E. PITMAN, *ibid.*, **12** (1920), 587.

<sup>2</sup> R. F. MACMICHAEL, *J. Ind. Eng. Chem.*, **7** (1915), 961; U. S. Patent 1,281,024 (1918).

inches long and of several sizes. It is inadvisable to permit more than two complete revolutions of the disk, as the wire may be strained beyond its limit of elasticity by so doing.

A critical study of this instrument has been made by Herschel.<sup>1</sup> He reports a number of possible and inevitable sources of error. The lines of flow above and below the disk are spiral instead of

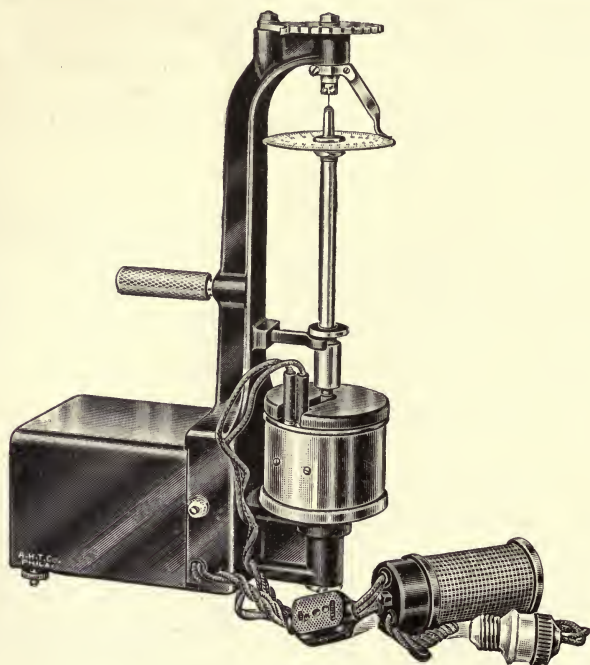

FIG. 89.—The MacMichael viscosimeter. (*Kindness of The Arthur H. Thomas Company of Philadelphia.*)

circular, due to the centrifugal action of the rotating liquid, and an error is introduced on account of an acceleration of the liquid.<sup>2</sup> A high speed results in a marked turbulence of the liquid, especially if of low viscosity. The deflection of the disk will be influenced, not only by the speed of the cup and the viscosity of the liquid, but also by the density of the solution. For these reasons it becomes impossible to employ a mathematical equation, which will define the absolute viscosity, calculated from the dimensions of the instrument.

<sup>1</sup> W. H. HERSCHEL, *J. Ind. Eng. Chem.*, **12** (1920), 282.

<sup>2</sup> HAYES and LEWIS, *J. Am. Soc. Mech. Eng.*, **38** (1916), 626; 1002.



For a given approximately uniform density of liquid, a given speed of rotation, and a given size of wire, it is however both possible and practicable to obtain readings that are very nearly straight line functions of the absolute viscosity. Since the absolute viscosity may not be accurately calculated from the dimensions of the instrument, it is necessary to obtain some kind of a standard of known viscosity for calibration. This should have very nearly the same density and the same order of viscosity as the liquids that are to be examined. Such standard liquids may be obtained from the Bureau of Standards in Washington. In calibrating the instrument, a wire of such size should be selected that, at the required temperature, a speed of from 20 to 60 revolutions per minute is required to obtain the same reading on the dial as corresponds to the certified viscosity of the liquid in poises or centipoises. Several different temperatures should be used with the standard in order that the scale interval corresponding to centipoises may be definitely established. Then by substituting any other liquid of approximately the same density the absolute viscosity in centipoises may either be read directly from the dial, or obtained by a very simple calculation.<sup>1</sup>

Too much stress cannot be laid upon the desirability of expressing all viscosity values in terms of the absolute unit—the centipoise.<sup>2</sup> When this is not done the values reported have only a very limited significance, and it becomes impossible to compare figures even between two instruments of the same make—much less between types as far apart as the pipette and the torsional apparatus. By taking the time to make this simple calculation, however, all values are in the same “language,” and the reports of any one investigator or tester become intelligible to every other investigator and tester.

### 3. THE MELTING POINT

The melting point of the jelly of a given gelatin or glue has often been regarded of importance in the estimation of the value of the material. Some investigators have considered this factor to be of fundamental importance, while others, perhaps most of them, have regarded a melting point determination only as a con-

<sup>1</sup> Cf. Appendix, page 608, for the calibration of the MacMichael Viscosity-meter.

<sup>2</sup> *Vide* page 384.

venient means of measuring the more generally conceded fundamental property of jelly consistency. The assumption is made, in these cases, that the melting point and the jelly consistency are always parallel functions.

**The Scientific Basis of the Melting Point Test.**—The methods that have been employed for measuring this property are for the most part unscientific, and give only rough approximations of the true value. It is, of course, by no means a simple matter to obtain accurate measurements of the melting point of such an amorphous substance as a gelatin jelly. For upon applying heat to such a body it gradually softens, gradually loses its shape, and after passing through all stages of a semi-solid and a semi-liquid, it finally melts to the consistency of a real liquid. The exact temperature at which the solid becomes liquid, or the liquid becomes solid is not easy to determine. In lieu, therefore, of this exact figure, certain arbitrary degrees of softening or congealing are usually taken as expressions of the melting point.

The reasons for the difficulty experienced in locating an exact melting point are probably to be found in the relations which Smith<sup>1</sup> has shown to exist between the sol and gel forms of the gelatin. Smith has found that from 0.6 to 1.0 per cent of the gel form must be present in any gelatin mixture at any temperature before gelation will take place, but that the presence of that amount will produce gelation. He accordingly gives a new definition to melting point as applied to gelatin, namely, that temperature at which, for any given concentration of gelatin, there will be 0.6 to 1.0 per cent only of the gel form present. At temperatures of 15°C. and below the gelatin will be entirely in the form of the gel. But as the temperature rises from 15 to 35°C. the ratio of percentage of gelatin in the sol form increases until at the latter temperature it is entirely in the sol condition. Consequently a pure gelatin of a concentration of 0.6 to 1.0 per cent will have a melting point at about 15°. Lower concentrations will not gel at any temperature. Every other concentration will have its melting point between 15 and 38°C., *i.e.*, that temperature at which 0.6 to 1.0 per cent only of the gel form is present. Obviously, the greater the concentration, the higher will be the

<sup>1</sup> C. R. SMITH, *J. Am. Chem. Soc.*, **41** (1919), 135; *J. Ind. Eng. Chem.*, **12** (1920), 878.

temperature, not exceeding 38°, at which the above condition will be realized.<sup>1</sup>

Smith has furthermore shown that in order for a true equilibrium to be established between the two phases, considerable time may be required—8 hours or more. If this amount of time is allowed, then it will be found to make no difference from which direction this temperature is approached; the melting point and the setting point will be identical. This is of importance, for statements have often appeared that, for example, the melting point was 28° and the setting point 24° for a given concentration.

*Effect of Hydrolysis on Melting Point.*—A further point must be brought to attention in this place. Gelatin which has been subjected to hydrolysis by the action of a high temperature, acids, alkalis or other means is converted, in proportion to the extent of such treatment, into a nongelatinizing substance consisting no longer of the protein gelatin, but, in its place, the cleavage products proteose and peptone. These have been called  $\beta$  gelatin. This material, being nongelatinizing, possesses of course no melting point in the sense in which we have used the term. Low grades of gelatin, and nearly all glues, contain more or less of this  $\beta$  gelatin, and the larger the amount of this form present, the lower will be the melting point of the whole. If, for example, a 10 per cent solution of pure gelatin contained the necessary 1 per cent only of gel form (*i.e.*, had its melting point) at 20°, a 10 per cent solution of glue which consisted of half  $\beta$  gelatin would require a lower temperature to give the necessary 1 per cent of gel form. That is, the melting point would be lower.

This explains the value of the melting point test for glues. The greater the percentage of the pure gelatin present, the higher will be the melting point. The greater the amount of hydrolyzed material present, the lower will be that value.

The findings of Smith are of especial significance in that they fully corroborate results obtained in the author's laboratory<sup>2</sup> through an entirely different procedure. These results indicate that the melting point and the jelly strength are parallel functions, other conditions being constant, and that the ratio between the protein gelatin and its products of hydrolysis vary propor-

<sup>1</sup> See Section on Structure, Chap. III.

<sup>2</sup> R. H. BOGUE, *Chem. Met. Eng.*, **23** (1920), 64; 105.

tionately with the jelly strength. That is, the melting point is proportionate to the ratio of  $\alpha$  to  $\beta$  gelatin in the glue, or, which is the same thing, to the "grade" of the glue.

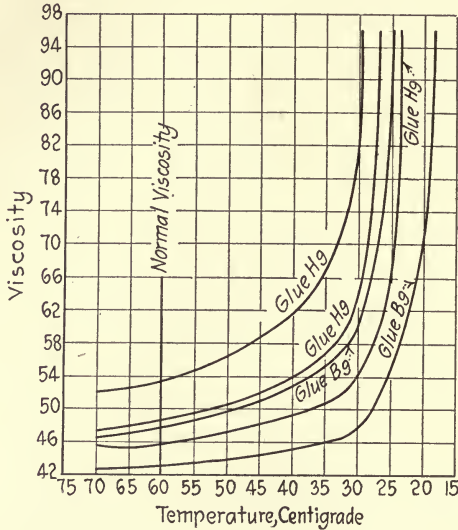

FIG. 90.—The relation of normal viscosity to melting point.

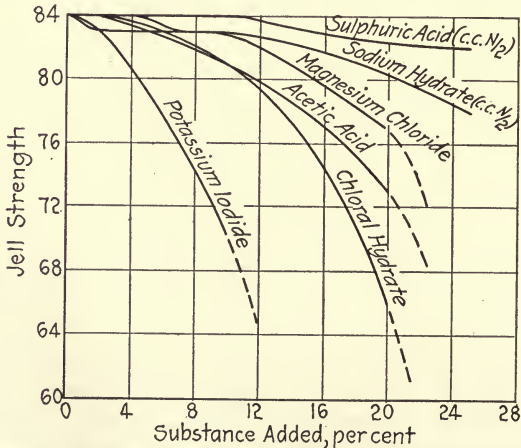

FIG. 91.—The effect of added substances upon jelly strength.

The relation between the viscosity and melting point is illustrated in Fig. 90, and the effect of the addition of various substances on jelly strength is shown in Fig. 91.



## Reasoning from Clerk Maxwell's elasticity theory

$$E = \frac{\eta}{T},$$

where  $E$  = the elastic modulus,  $\eta$  = the coefficient of viscosity, and  $T$  = time of relaxation, *i.e.*, time for a deformation to fall to  $1/e$  of its initial value, Sheppard and Sweet<sup>1</sup> point out that the "melting point" is the temperature at which the elastic modulus becomes very small. Since  $\eta$  remains of considerable magnitude, this can only be by  $T$  becoming very large. Hence they

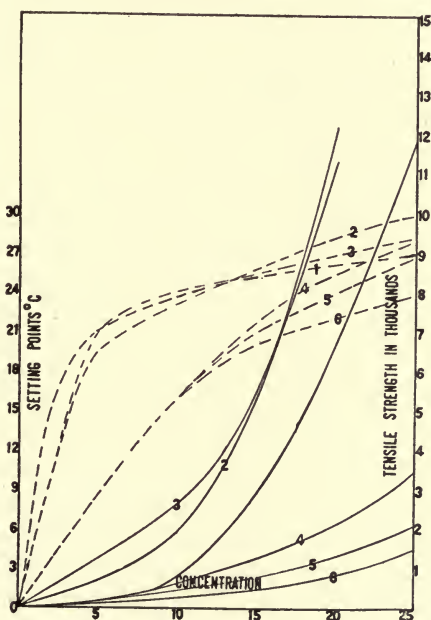

FIG. 92.—The relation between setting point and tensile strength, plotted against concentration.

define both "melting point" and "solidification point" (setting point) as "the convergence temperature at which the 'time of relaxation' becomes infinite."

Comparative curves obtained by the use of a special apparatus (see below) indicate that setting point (or melting point) concentration curves of different gelatins may cut each other at varying points. This, they argue, makes it dangerous to attempt

<sup>1</sup> S. E. SHEPPARD and S. SWEET, *J. Ind. Eng. Chem.*, **13** (1921), 423.

to evaluate gelatins by melting points at any given fixed gelatin concentration, but they suggest that a comparison of the curves over a range of concentrations, as from 0 to 50 per cent, would adjust the difficulty.

They also show that the above curves are not parallel to the jelly strength-concentration curves, and that the same order of grading would not result by the two methods. Figure 92 shows a comparison of the two sets of curves presented by Sheppard and Sweet.

The use of the melting point as a criterion for the evaluation of a glue is based, of course, upon the hypothesis that the melting point is a measure of the adhesive strength of the material. This assuredly does not apply to all kinds of glues, since liquid marine glues, and animal glues which have been rendered nongelatinizing by the addition of some foreign substance, still may possess a high degree of adhesive strength. And Herold<sup>1</sup> has even gone so far as to state that, even in animal glues, the presence of gelatinizing gelatin is actually a drawback to the adhesive power of the glue. He regards as the best glue that which contains a minimum of gelatin, and a maximum of nongelatinizing protease. Consequently Herold considers a low melting point a low viscosity, and a low jelly strength as the *desiderata* in glue evaluation. We admit, because of the high adhesive strength of some nongelatinizing glues, that further investigation is necessary before this point can be definitely settled, but it is surely the common experience of most investigators and users of glue that, in general, a high melting point, a high viscosity, and a high jelly strength are expressive of a high adhesive strength, and that, as these factors decline, the adhesive strength will also become less. Experiments made in the author's laboratory<sup>2</sup> point very emphatically to this conclusion. No other factor was found so correctly to parallel the actual adhesive strength of a glue as its melting point.

**The Methods for Measuring Melting Point.** *Chercheffski's Method.*—A method suggested by Chercheffski<sup>3</sup> in 1901 is based upon a measurement of the temperature at which small cubes of the jelly become soft enough to lose their cohesion. His apparatus, Fig. 93, consists of a 250 c.c. beaker containing pale

<sup>1</sup> J. HEROLD, *Chem. Ztg.*, **35** (1911), 93.

<sup>2</sup> R. H. BOGUE, *Chem. Met. Eng.*, **23** (1920), 64; 197.

<sup>3</sup> CHERCHEFFSKI, *Chem. Ztg.*, **25** (1901), 413.

petroleum oil. Across the top of this is placed a glass rod. One end of a Z-shaped brass wire is coiled around the rod and the other horizontal end is immersed in the oil near a thermometer. Small cubes of gelatin or glue, of about 5 mm. to a side, and of a standard concentration are skewered onto the wire, and the temperature of the oil slowly raised until the cubes liquefy and drop off. This temperature is noted as the melting point.

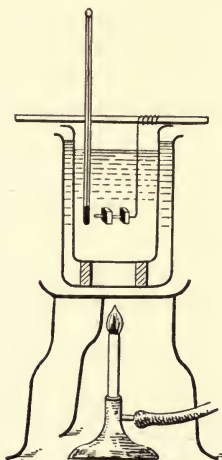

FIG. 93.—Chercheffsky's method or the measurement of melting point.

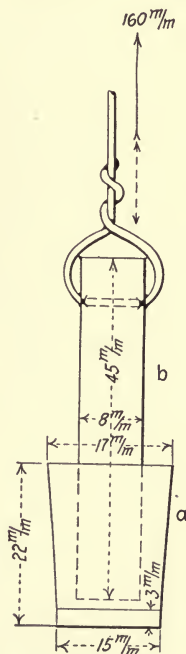

FIG. 94.—Cambon's fusiometer.

*Kissling's Method.*—The temperature at which a glue became sufficiently mobile to flow was measured by Kissling.<sup>1</sup> He dissolved 15 grams of glue in 30 c.c. of water and poured the solution into a wide test tube. The contents were chilled by immersing in water at 15°C. for one hour. The melting point was then determined by placing the tube horizontally in warm water, and noting the temperature at which the surface of the glue became inclined.

<sup>1</sup> KISSLING, *Z. angew. Chem.*, **17** (1903), 398.

*Winkelblech's Method.*—Winkelblech<sup>1</sup> placed 400 c.c. of a standard glue solution in a 500 c.c. flask and shook in cold water until a consistency of jelly was reached at which a thermometer placed therein remained stationary for some time. This temperature he recorded as the gelation point.

*Combon's Fusiometer.*—The method of determining the melting point by the use of Combon's fusiometer, as described by Küttner and Ulrich,<sup>2</sup> has been regarded as more or less of a standard procedure for many years. In principle it is much the same as the foregoing methods. The apparatus consists of a metal bowl 22 mm. high, 17 mm. in diameter at the top, and 15 mm. at the bottom. The prescribed weight is exactly 7 grams. The solution of glue or gelatin to be tested is poured into the bowl, and a rod inserted and maintained in an upright position until the contents have congealed. The apparatus is then suspended in a beaker of water at 15°C., the beaker placed in a water bath at 50°, and the water in the latter slowly heated (about 1° per minute) until the bowl falls off from the rod. The temperature of the water in the beaker when this occurs is taken as the melting point of the substance. A concentration of 20 per cent is recommended. By this procedure the best glues show a melting point of 30° or above, and intermediate grades from 24 to 29°C.

*Herold's Method.*—Herold<sup>3</sup> employed a somewhat similar, but less accurate, method. A thermometer, graduated to tenths of a degree, was allowed to be congealed into a test tube of gelatinizing jelly and, when the gelation was complete, the test tube was suspended in warm water by means of the thermometer. The temperature at which the tube fell away was noted as the melting point. Herold claims that by careful manipulation it is possible to obtain results which may be duplicated to 0.1 to 0.2°. He specifies that the tube should be small, the space between the bulb of the thermometer and the wall of the tube being about 1 mm. The temperature of the water bath should not be more than 1.5 to 2.0° higher than the expected melting point of the jelly. He reported that the melting point concentration curve is a straight line, and that the relative values of two samples are proportional to the tangents of the angles of inclination of these lines to the horizontal.

<sup>1</sup> WINKELBLECH, *ibid.*, **19** (1906), 1260.

<sup>2</sup> KÜTTNER and ULRICH, *Z. öffent. Chem.*, **13** (1907), 121.

<sup>3</sup> J. HEROLD, *Chem. Ztg.*, **34** (1910), 203.



*Sammet's Method.*—Sammet<sup>1</sup> suggested that, for comparative purposes, the relative order in which several glue jellies liquefied when heated on a brass strip served as an indication of jelly strength, and hence of the value of the glue. His method is to soak the granulated glues in cold water for one minute, then place small amounts of the swollen substance near the end of a brass strip, and place the end of the strip, bent at an angle, into water at 40°C. Similarly treated portions of standard glues are placed beside the samples, and the comparative order of the melting point noted by observing the order in which the several portions melt and run off the strip.

*Clark and DuBois' Method.*—The procedure of Clark and DuBois<sup>2</sup> has as its object the determination of "jelly value" in terms of the minimum percentage of glue or gelatin which will remain in solid phase when, after putting into solution and cooling to well below 10°, it is brought gradually up to 10°C. This is, in reality, a determination of melting point. The several samples are made up in a number of different concentrations, and the lowest concentration that will produce a jelly at the specified temperature (10°) is taken as the "jelly value." Obviously, the higher the quality of the material examined, the lower will be the "jelly value."

*Smith's Method.*—The procedure adopted by C. R. Smith<sup>3</sup> for determining the exact melting point was as follows: He cooled the sol to 2 or 3° below the expected temperature, left it at this temperature until the gel was produced, and then transferred to a constant-temperature bath held at the expected temperature. He selected an arbitrary standard of rather high viscosity as the state most accurately representative of the melting point. At the correct temperature the gel should show continuously for several hours the selected condition of viscosity. The particular viscosity employed by Smith as the transition point from sol to gel was determined by permitting a bubble of air 4.5 mm. in diameter to move vertically upward through a polariscope tube containing the gelatin. At the specified viscosity the bubble should move with a scarcely perceptible motion of about 1 cm. in 4 seconds.

*Sheppard and Sweet's Method.*—The apparatus of Sheppard and

<sup>1</sup> C. F. SAMMET, *J. Ind. Eng. Chem.*, **10** (1918), 595.

<sup>2</sup> A. W. CLARK and L. DUBOIS, *J. Ind. Eng. Chem.*, **10** (1918), 707.

<sup>3</sup> C. R. SMITH, *J. Am. Chem. Soc.*, **41** (1919), 146.

Sweet<sup>1</sup> is designed to measure directly the melting point and the setting point of gelatins. The principle is as follows: "An intermittent stream of air bells, under constant pressure, is passed through the test solution, the latter being cooled with ice water. A thermometer is immersed with its bulb next to the air

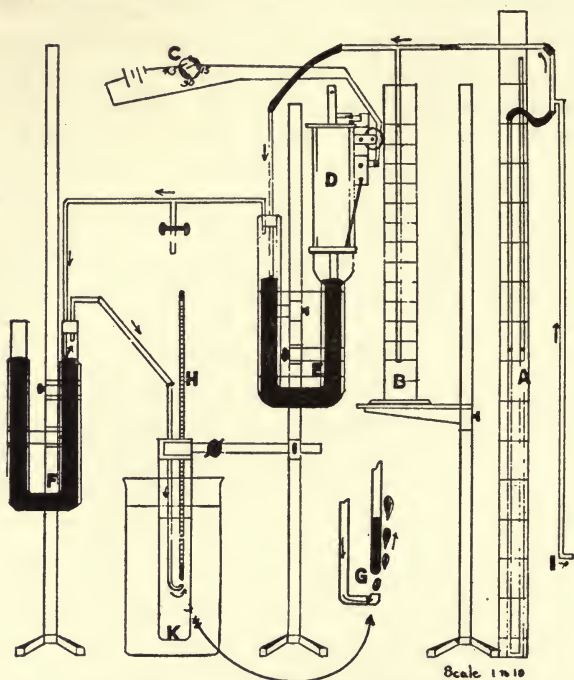

FIG. 95.—The melting point apparatus of Sheppard and Sweet.

passage, and the temperature at which the bubbles cease to pass is taken as the 'setting point.' Inversely, after sufficient undercooling, the set jelly is surrounded with water at a definite higher temperature, and the 'melting point' taken as the temperature at which bubbles again pass through." The operation of the instrument will be evident from Fig. 95.

"Compressed air passes manometer A and the manostat bottle B to the first U-tube E, containing mercury. This tube is used as a valve to produce intermittence in the delivery of air. A solenoid, D, the current through which is made and broken by the timer C every 15 seconds, effects this interruption by operating

<sup>1</sup> S. E. SHEPPARD and S. SWEET, *J. Ind. Eng. Chem.*, **13** (1921), 423.

an iron plunger. From this U-tube E the air passes the compensating U-tube F to the setting or melting tube K. The outlet in K is shown in detail at G. To obtain satisfactory and reproducible results with this apparatus the following precautions are necessary:

1. Fifteen-second intervals between passage of air bells.
2. Slow flow (*i.e.*, slight overpressure).
3. Exit at definite depth below surface.
4. Water in compensation tube at same level throughout the test."

An alternative melting point apparatus is also described by

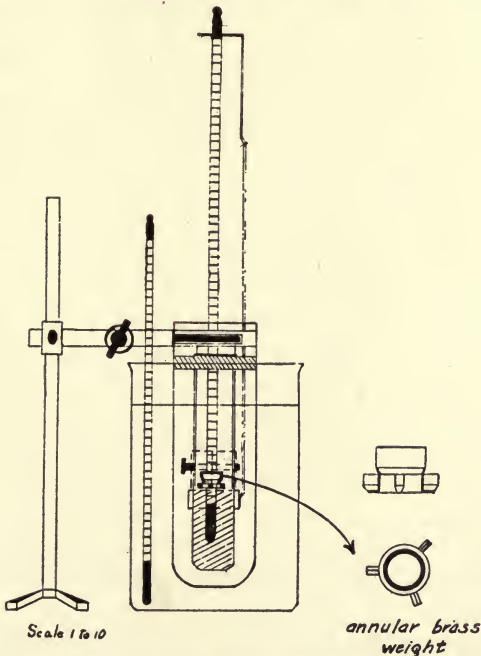

FIG. 96.—The alternative melting point apparatus of Sheppard and Sweet.

Sheppard and Sweet, designed for more rapid but less accurate measurements. This is shown in Fig. 96.

"The jelly is set in a test tube with a thermometer centrally embedded, the bulb being just below the surface. Round this thermometer slips a small test piece, resting on the jelly by three equidistant wedge-shaped feet. The test tube is air jacketed and

heated at a constant rate, and the temperature read. The point at which the tester just begins to penetrate the jelly surface is taken as the softening or yield point, and the temperature at which the tester has sunk just above the feet as the melting point." There is a slight error in the use of this instrument due to the skin formation, but it is very small.

*Bogue's Method.*—The author<sup>1</sup> has pointed out that, if the melting point may be assumed to be represented by the temperature at which a solution of glue or gelatin will no longer flow at all from the orifice of a viscosimeter tube, then it becomes a comparatively easy matter, by taking a series of viscosity readings at decreasing temperatures, to plot the temperature at which the viscosity would, with that instrument, reach infinity, *i.e.*, would cease altogether to flow. In principle, this is similar to the method of Smith, but it makes use of a more easily measurable property. The author also found that, at temperatures near the setting point, the higher the viscosity, the higher also would be the temperature of gelation. It therefore becomes permissible to employ the actual viscosity measurement at temperatures near the setting point, *e.g.*, 30 to 35°C., as a measure of melting point. Advantage has accordingly been taken of this relationship by making viscosity determinations at these temperatures.

The advantages gained by such a procedure are, first, that an easily measurable property is determined, rather than the more difficult and rather hypothetical melting point, and second, that a much wider range of values are obtainable. That is, the melting points are limited to between 15 and 35°C., accurate to perhaps 1 or 2°, while the viscosity, when measured by the MacMichael instrument, and expressed in centipoises, was found to vary from about 10 in the lowest to above 150 in the highest grade glues, at 35°C., and are easily duplicatable to 1°.

By the above method, therefore, the melting point may be either computed in terms of actual temperature of gelation, by taking several viscosity readings at different temperatures near the gelation point, or the viscosity in centipoises at some stated low temperature may be determined, and expressed as an indirect measure of melting point. Such determinations were found very accurately to parallel the adhesive strength of the glue.

<sup>1</sup> R. H. BOGUE, *Chem. Met. Eng.*, **23** (1920), 64; *J. Ind. Eng. Chem.*, **14** (1922), 435.



#### 4. THE ADHESIVE STRENGTH

Whenever glue is to be used as a binding agent in joint or veneer work, the actual strength which may be developed in the joint or panel by the use of a given glue is of course of the greatest importance. It is essential for good results that a certain minimum of strength shall always be produced.

On account of the difficulties encountered in making the test such that the results will be reliable and always comparable, there have been very few attempts on a commercial or laboratory scale to include the adhesive test in specifications. The most noteworthy exception to this is the specifications of the United States War Department for glue to be used on airplanes. In general, however, recourse has been had to other more easily performed tests, such as the jelly consistency, viscosity, and melting point, in the belief that these properties represented, to a certain extent at least, the order of differentiation that would be found by the actual joint strength test.

A detailed discussion of the adhesive strength of glues, and the factors affecting the same is given in Chap. XI, pages 517 to 534.

#### 5. THE TENSILE STRENGTH AND ELASTICITY

The tensile strength of the glue has frequently been suggested as the property upon which the adhesive properties ultimately depended, but very little advance has been made in the development of this test on account of the technical difficulties encountered. Most important of the difficulties experienced is the impossibility of obtaining strips of the dried glue which are quite free from stresses and strains set up during the drying process, except in the possible instance of very thin specimens. And even in the latter there is great uncertainty until the test has been completed and the nature of the break ascertained.

In recognition of these difficulties, and in order to avoid them, Setterberg<sup>1</sup> used strips of paper dipped in the solution of glue, dried, and pulled apart. Gill<sup>2</sup> was not able to obtain satisfactory results by this method, and modified the procedure by determining the bursting strength of the glue-treated paper by the use of the Mullen paper tester. He dipped strips of filter paper

<sup>1</sup> SETTERBERG, *Svensk. Kem. Tid.*, **28**, 52.

<sup>2</sup> A. H. GILL, *J. Ind. Eng. Chem.*, **7** (1915), 102.

2 inches wide into a 25 per cent solution of glue, and allowed them to dry in the air for 36 hours. The paper was then cut into 2 inch squares, weighed, and broken by the Mullen paper tester, which measures the force required by a rubber knob to burst through the paper. The results were calculated to a basis of the breaking pressure per 100 mg. of glue per 4 square inches of surface. Gill reports that the results were much more concordant than any that were obtained by any other means, giving data that did not vary more than 10 per cent. The test, however, does not give results that may correctly be termed tensile strength.

A method by which this property may be more accurately measured has been described by Hopp.<sup>1</sup> His method consists in making molds of the glue jelly, allowing to dry, cutting and trimming to a standard size, and finally pulling apart in a tensile machine. He uses solutions containing 60 to 80 per cent by volume of glue, warms to 160°F., and pours carefully into an iron mold 12 by 12 by  $\frac{1}{4}$  inch deep. The glue is permitted to set for 5 hours, and the jelly then removed and placed on a fine wire gauze. Air currents are not permitted. The jelly is turned frequently, and strains prevented by cutting slits  $\frac{1}{4}$  inch deep into the glue as it dries out. When thoroughly dried the sheet is cut into strips by a hot knife, and cut or ground to a definite shape and size. His most favorable dimensions were 0.1 inch in thickness, 0.33 inch in width, and 7 inches in length. A length of 2.5 inches was indented at the center of the strip to insure its breaking in that area. The tensile strength and also the stretch before breaking were measured on a Schopper machine.

The results reported by Hopp are remarkable in their uniformity upon duplicate samples. The maximum deviation from the average of 17 determinations upon one lot was only about 5 per cent. The stretch was not as consistent, but showed a distinct tendency to be greater in the stronger glues. Much more work is necessary upon the exact relations which obtain between tensile strength, stretch, and adhesive strength before the value and applicability of this new test is definitely placed, but if corroborative evidence is developed showing a ready adaptability to glue house technique, and an unquestionable conformity for all glues, there is no reason why it should not constitute a valuable addition to our tests for glue evaluation.

<sup>1</sup> G. HOPP, *J. Ind. Eng. Chem.*, **12** (1920), 356.

## 6. THE OPTICAL ROTATION

Smith<sup>1</sup> has demonstrated that a nicely balanced equilibrium exists in glues and gelatins<sup>2</sup> between the sol and gel form of the protein, and that this equilibrium is reflected both in the jellying power of the material and in the degree of mutarotation between 35 and 15°C. By studying a number of glues of different grades, Smith found, first, that the minimum concentration of glue

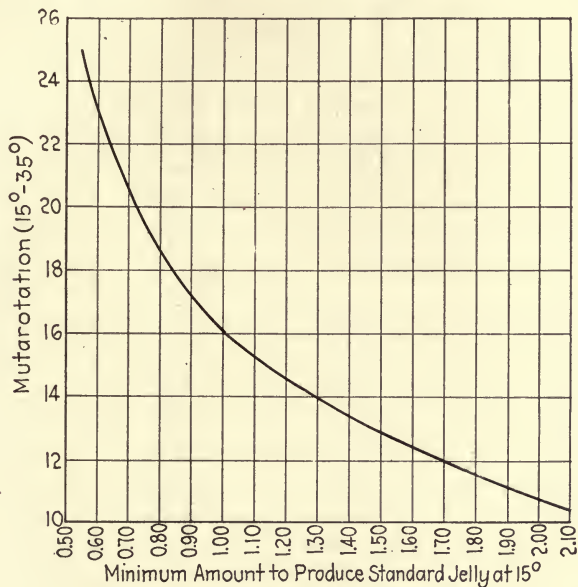

Fig. 97.—Mutarotation and jellying power. (From data of C. R. Smith.)

necessary to produce a jelly of a standard consistency decreased as the apparent purity and gelatin content of the sample, and second, that the change in rotation (mutarotation) of a given concentration of the glue between 35 and 15°C increased with increasing purity of the material. He suggests therefore that the change in rotation of a 3 per cent solution of glue between 35 and 15°C. be employed as a measure of the jelly strength. For example, if a sample polarizes at  $-20.5^{\circ}$  V. at 35°C., and at  $-40.0^{\circ}$  V. at 15°C. in a concentration of 3 grams per 100 c.c., it is suggested that the strength be expressed as 19.5 points at 15°C., the increment in rotation in Ventzke degrees.

<sup>1</sup> C. R. SMITH, *J. Ind. Eng. Chem.*, **12** (1920), 878.

<sup>2</sup> See pages 117 to 119.

The significance of such a system will be understood by a reference to the following table which is taken from a more extensive one by Smith.

TABLE 47.—MUTAROTATION AND JELLYING POWER

Minimum amt. to produce standard jelly at 15°C.	Rotation, °V., 3 g. per 100 c.c. in equilibrium 35°C.	Rotation, °V., 3 g. per 100 c.c. in equilibrium 15°C.	Mutarotation
Bone Glues			
2.10	-19.8	-30.2	10.4
1.60	-20.2	-32.4	12.2
1.45	-20.1	-33.4	13.3
1.40	-20.6	-34.1	13.5
1.40	-21.0	-33.8	12.8
0.96	-20.3	-36.6	16.3
0.88	-20.4	-37.6	17.2
0.89	-20.4	-36.8	16.4
0.77	-20.5	-40.0	19.5
0.80	-20.7	-39.0	18.3
0.78	-21.0	-40.2	19.2
0.80	-20.7	-40.0	19.3
0.72	-20.1	-40.0	19.9
0.72	-20.5	-41.6	21.1
0.70	-21.3	-42.0	20.7
0.68	-20.7	-43.2	22.5
0.67	-21.4	-43.9	22.5
0.67	-21.0	-42.8	21.8
0.58	-20.8	-44.4	23.6
0.58	-20.3	-44.9	24.6
0.55	-21.3	-46.2	24.9
Hide and Sinew Glues			
0.55	-20.9	-45.0	24.1
0.69	-20.7	-41.2	20.5
0.88	-21.1	-38.0	16.9
0.64	-21.5	-44.2	22.7
0.69	-20.7	-42.4	21.7
0.57	-20.5	-43.6	23.1
0.80	-20.3	-39.0	18.7
0.95	-20.4	-36.3	15.9
0.87	-21.0	-38.4	17.4
1.09	-20.6	-36.2	15.6
1.35	-21.3	-33.2	11.9
1.60	-20.2	-31.8	11.6
3.50	-19.6	-25.6	6.0
5.30	-19.0	-22.9	3.9
1.35	-20.0	-34.0	14.0
2.60	-19.3	-27.2	7.9

In the first column is shown the minimum percentage of glue necessary to produce the standard jelly at 15°C. The standard



jelly is such "that a bubble of air 4 to 5 mm. in diameter admitted to the polariscope tube moves vertically with a scarcely perceptible motion of 4 cm. per second." The second and third columns show the rotation in Ventzke degrees of a 3 per cent solution at 35 and at 15° respectively. The last column shows the motarotation, *i.e.*, the change in rotation suffered by the glue on passing from 35 to 15°.

It will be observed that as the jelling power increases the motarotation also increases. (The smaller the minimum percentage of glue necessary to produce the standard jelly, the greater is, of course, its jelling power.) The precise nature of the variation is shown to better advantage by the curve in Fig. 97 prepared by the author from Smith's figures. It is, unfortunately, not a straight line curve. It would, however, be a simple matter to prepare a chart showing the approximate relation between any given jelly consistency, as ordinarily determined, and the mutarotation.

Smith proposes the use of the polariscope, applying the above principle, to the grading of glues and gelatins, and to factory control. A 3 per cent solution is polarized in a 2 dm. tube at 35°C., then a portion of the solution cooled rapidly to 15° and transferred before the sample has jellied to a cold 1 dm. tube. This is left in the ice-box over night, and the next day placed in a constant temperature bath at  $15 \pm 0.4^\circ$  for 4 to 7 hours, and the polarization noted. It is sometimes necessary to clarify the solution, which is done by digesting with 5 c.c. of light powdered magnesium carbonate at 30 to 40°C. for one hour or longer, and filtered.

Although the findings of Smith are of considerable interest from a theoretical viewpoint, it seems questionable if the additional information gained is of sufficient importance to justify the incorporation of the polariscopic test into the glue shop for grading or control purposes. The apparatus is expensive, the time for testing long, and the skill in technique much more exacting than is required in other procedures.

## 7. THE SWELLING CAPACITY

The degree of swelling, or differently expressed, the amount of water which a given weight of a glue or gelatin will absorb, has

occasionally been used as a test for evaluation.<sup>1</sup> If every other disturbing influence were eliminated, it would be found that the degree of swelling would increase in proportion to the protein content of the sample. But there are such a large number of influences which are of very appreciable magnitude that modify this factor<sup>2</sup> that it must be regarded as of only secondary importance in evaluation.

The hydrogen-ion concentration of the glue is responsible for wide variations in swelling capacity. The ions of many salts produce marked changes. The previous history of the substance is of importance. A glue dried out from a dilute jelly will absorb more water than if the concentration of the jelly is high. The purity of the water in which the sample is placed, its temperature, and its relative volume, are all important sources of fluctuation in swelling capacity. For these reasons the test has not been generally used.

#### 8. THE RATE OF SETTING

For some uses to which a glue is put it is very desirable to have some information upon the comparative rapidity with which it sets to a jelly. Wherever glue is used at such concentrations that a jelly results upon cooling to room temperature it must, of course, be handled with alacrity, for if the glue sets before a joint, for example, is completed, the full value of the adhesive cannot be realized. In general, however, the rate of setting is reasonably well gaged by the viscosity or the jelly strength. Where direct data are desired, however, they may readily be obtained by comparing the time required for the several solutions of equal concentration and temperature to reach any given consistency.

#### 9. THE FOAM TEST

A glue that foams badly is regarded with disfavor by practically all consumers of the material. When the glue is used only in small amounts and applied by hand, the presence of foam is not especially embarrassing, but when used in large amounts and applied by rotary brushes or rollers, its presence may be very

<sup>1</sup> SHATTERMANN, *Dingler's Polytech. J.*, **96** (1845), 115.

<sup>2</sup> See page 164, *et. seq.*

troublesome. Manufacturers also find difficulty, in the evaporation *in vacuo* operation, if the glue foams badly.

The most exhaustive study that has been made of this annoying property of glues seems to have been that reported by Trotman and Hackford<sup>1</sup> in 1906. Preliminary to the investigation proper they studied the various methods that were in use for the measurement of foam, and found them to be inadequate for exact determinations. They found that not only must equivalent concentrations of glue be employed but containers of uniform dimensions must be used, as the foam figure increases with decreasing diameter of the tube or tumbler (from 7.5 to 17.5 on decreasing the diameter from 2 to 1 cm.); the height of the liquid in the tubes must be the same, as the foam increases with increasing height of liquid (from 3 to 22 on increasing the height from 5 to 25 cm.); and the temperature must be the same, as the foam figure decreases with increasing temperature (from 30 to 3.5 on raising the temperature from 30 to 100°C.).

The apparatus and technique for foam measurements that was finally adopted is as follows: A graduated tube 70 cm. in length, and of such diameter that 1 c.c. is measured by a 1 cm. graduation, is half filled with the glue solution, and placed in a water bath maintained at 60°C. After the temperature has become constant the height of the glue column is adjusted so that it reaches the zero mark at which point there will be exactly 25 c.c. of solution present. The tube is then corked and shaken vigorously for a half minute, and the upper point of the foam read off. This represents the cubic centimeters of foam obtained under the conditions employed, and is called the *foam figure*.

The results of the investigation of Trotman and Hackford may be stated very briefly:

1. The presence of peptones in the glue very markedly increases the foam figure, especially in low concentrations. Ten parts of peptones to 100 parts of albumose raise the foam figure 13 c.c., but 100 parts of peptone to 100 parts of albumose raise the figure only 20.5 c.c. This is taken to signify that high grade glues, which contain relatively small amounts of peptone, will show a relatively small amount of foam as compared with the the lower grades of glues which are highly hydrolyzed. This was further evidenced by an increase in the foam figure from 16 to 24 resulting from the boiling of a glue for 24 hours.

<sup>1</sup> S. TROTMAN and J. HACKFORD, *J. Soc. Chem. Ind.*, **25** (1906), 104.

2. On boiling with alkalis there seems to be little change in the foam figure until rather large amounts of the alkali are present. Ammonium carbonate produces the greatest increase in foam at low concentrations. In the cold, sodium hydroxide produces a decided increase. Lime is practically without effect. Ammonia produces a slight decrease.

3. Bone oil, oleic acid, cod oil, and lubricating oil produce a decided decrease in foam, but paraffin oil, olive, castor, neats foot, rape, and cedar oils were without effect.

4. Small amounts (up to 5 per cent) of potash and soda soaps effected a decrease in foam, but large amounts resulted in an increase.

5. Most acids produce a slight decrease in foam. On account of the hydrolyzing effect, however, they are not recommended for that purpose.

6. Insoluble substances suspended in the glue invariably produced an increase in foam, a 5 per cent admixture of zinc oxide, for example, raising the figure 12 c.c.

7. The presence of soluble salts such as might be found in the water used has very little effect upon foam.

An excessive amount of foam appearing during the evaporation *in vacuo* of the glue liquor may be prevented, according to Garry,<sup>1</sup> by increasing the temperature at the foaming point and decreasing it in the liquor. That is, full pressure steam would be cut off in the lower coils.

There is no satisfactory method for eliminating foam when it appears during the spreading, the sizing operations, etc., to which it may ultimately be put. Sometimes a little grease is added, if the latter will not produce in itself serious difficulties. Since alkaline glues foam more than acid glues, acids are sometimes added to neutralize any alkalinity present.

In some uses to which gelatin is put, foam is desirable. Thus in the manufacture of marshmallows and confectionery foaming is of importance as it adds to the volume and firmness of the beaten constituents.

## 10. THE GREASE TEST

Unless precaution is used during the manufacture to remove grease and fatty matter, the presence of this material will

<sup>1</sup> H. GARRY, *J. Soc. Chem. Ind.*, **25** (1906), 108.



always be manifest in glue. Bones are sometimes treated with fat solvents before boiling, but it is also common practice in this country to remove the fatty substance during the cooking of the stock, or the subsequent standing of the same, by the simple process of skimming. As long as fat sells for a higher price than glue, it is certain that a reasonable effort will be made to remove as much as practicable from the glue, but in spite of this there is oftentimes an appreciable amount of fat that has not been removed.

The principal objection to the presence of grease in glue lies in the fact that it is immiscible with the latter, and consequently on spreading leaves a number of droplets of oil on the surface coated. As oil is not an adhesive, the joint strength of the glue will be diminished in proportion to the area occupied by these droplets. In the manufacture of sized or glazed papers, especially in colored papers where the glue is admixed with the coloring material, the presence of much grease is impermissible, as it would unmistakably manifest its presence by the formation of small round "eyes" or light spots in the product. In clay-treated wall papers the use of a greasy glue is usually regarded with disfavor, but Fernbach<sup>1</sup> insists that its use is, on the contrary, an advantage, in that it makes for a more brilliant pigmentation, a greater smoothness of flow from the roller, and a minimizing of the possibility of foaming.

The presence of grease is shown by adding a water solution of a dye, as turkey red, magenta, or methyl violet, to the glue solution, and by means of a clean flat brush making even streaks of the mixture across a sheet of greaseless paper. The grease manifests itself by producing the typical "eyes" or pale elliptical spots throughout the streak.

## 11. THE REACTION

A test that has worked its way into the usual routine procedure of glue testing, but which is only rarely made use of intelligently, is the simple litmus paper test for acidity or alkalinity. Strips of the red and blue paper are dipped into rather thick solutions of the glues, and notation made as to whether the latter appear to be acid, alkaline, or neutral. The test is not especially sensitive in the presence of the colloid material of the glue, and the

<sup>1</sup> R. FERNBACH, "Glues and Gelatin," New York (1907), 31.

value of the test, except as an indication of high acidity or alkalinity, is questionable.

In the manufacture of glue, the hide stock is usually treated with lime. This lime may be washed out in large measure, but a large enough amount may be left in the stock to produce an alkaline reaction in the glue. If the lime is neutralized with some acid, a slight excess of acid will often remain, and be the cause of an acid reaction in the product. Bones that have been treated with acid to dissolve the calcium phosphate will usually produce an acid glue.

For adhesive purposes it is not considered to matter whether the glue contains acid or alkali, or is neutral, unless those substances are present in large amounts. In such case, an hydrolysis will take place upon bringing the glue into solution, and an unusually rapid depreciation in strength upon maintaining the solution at the handling temperature (60°C.) may result. In small amounts acid is considered to be rather more desirable than alkali as the former is a less favorable medium for the growth of bacteria and putrefactive organisms.

The presence of more than traces of either acid or alkali is detrimental in glue that is to be used as a size upon colored paper or cloth, on account of the possibility of a reaction taking place between the color, or its precipitating agent which is often incompletely washed out, and the electrolyte. In papers where clay is employed, the presence of an excess of acid or alkali in the glue may also result in a flocculation of the colloid particles of the clay, causing the latter to lose their smoothness and become granular or lumpy.

A much more satisfactory method for determining the reaction of a glue solution consists in a measurement of the hydrogen ion concentration. (See page 500 and Appendix, pages 579 to 606.)

## 12. APPEARANCE, ODOR, COLOR, KEEPING QUALITIES, ETC.

The general appearance of a glue, its odor, color, brittleness, and the like, are the properties that are first brought to the attention of any person who is examining samples of glue or gelatin. Although these properties are not, as a general rule, made very much use of in actual evaluation, yet to the man who is familiar with glues they mean much, and, even to the casual

observer, certain extremes cannot pass without revealing their significance.

**The Inspection Test.**—A good glue will be firm; free from the development of a large number of cracks, called *craze*; will preferably be clear and translucent unless rendered opaque with some added material; it may be light amber or dark brown, but never black; it will not break easily when bent, but will show resistance to pressure and will be elastic; it will not have a disagreeable or decomposed odor, even after making into solution; and it will not quickly develop such an odor on remaining in solution.

If the glue is badly crazed, it is a very weak sample. If it is muddy in appearance, or very dark brown and opaque, it signifies that the sample was from the last runs of the cooking, and contains the dregs of the stock and the excessively hydrolyzed material. Light amber colored glues, either clear or otherwise, are more likely to be of bone origin, while the light and dark brown glues are more probably obtained from hide, fleshing, and sinew stock. By breathing upon a sample and noting the odor, the bone glues can usually be distinguished by a characteristic, rather pungent, odor. A speckled appearance may be traced to a precipitation of calcium or barium sulphate, due to an improper treatment in the bleaching process. Flakes of the highest grade glues may be bent double without breaking, while the poorer samples may be broken, unless too thick, with the least amount of pressure between the fingers. Glues that have undergone bacterial decomposition will give off putrefactive odors, even when dry, but these will be highly intensified when the sample is put into solution. A good glue should remain perfectly sweet for at least 48 hours after being put into solution.

The form in which the glue is put on the market is not, as many have believed, indicative of some particular grade or line of material, but is rather to satisfy the belief of certain consumers that such is the case. Before modern methods were introduced into glue-house technology glue was made by a large number of small plants scattered widely, and as a rule all of the glue from any one plant was put out in the same form. Consumers thus fell into the error of associating certain desirable properties of glue with the form in which that particular glue was marketed, and this created a demand for certain forms that has existed to the present, although there is now no foundation for such a



distinction. A given glue is now made, in a given plant, into sheet glue, ribbon glue, thin cut flake glue, thick cut flake glue, ground glue of various sizes, and powdered glue. The essential properties of the several forms are identical.

There is, however, a tendency to make the higher grades of glue thin cut. The product has a clearer, more translucent, and lighter color, but the lower grades cannot be made very thin, as they would too easily break into small fragments. The thick sheet and ribbon glues are usually a rather low grade bone product. There has been an objection to the use of ground glue on the stand that it was more easily susceptible of adulteration with inferior material when in that condition, without the fact being made manifest by the appearance of the glue. This is an unwarranted objection at present, for nearly all glue is now bought and sold on specification, and if mixtures are made it is with the knowledge and permission of the consumer. On the other hand, there is a distinct advantage in the use of ground glue, as the time required to put into solution is very materially shortened, and the space occupied by a given weight is much less when in the ground condition.

Sheppard<sup>1</sup> has suggested that such expressions as "water-clear" may very advantageously be replaced by a definite per cent of clarity, and definite colorimetric values, where color is a factor. He proposes to use for this purpose the principle of crossed gratings, on lines similar to those employed by Ives<sup>2</sup> in his test object for visual acuity. The apparatus consists of "two superposed opaque line gratings arranged to rotate relatively to each other about an axis perpendicular to their plane. Viewed by transmitted light, at such a distance that the grating lines are below the limit of resolution, parallel dark bands are seen. The separation of these alters quite continuously as the gratings are rotated, so that we have a continuous change from extreme visibility to invisibility when the bands can no longer be resolved."

**Crazed Glue.**—Some of the lower grades of glue break at the slightest pressure, and on inspection of such a piece it is observed oftentimes to be traversed by a large number of fine cracks. In extreme cases the whole mass will crumble to small cubical and rectangular fragments ranging usually from a thirty-

<sup>1</sup> S. E. SHEPPARD, *J. Ind. Eng. Chem.*, **12** (1920), 167.

<sup>2</sup> H. E. IVES, *Elec. World* (1910), 939; *J. Optical Soc. Am.* (1917), 100.



second to an eighth of an inch on a side. Such a glue is spoken of as *crazed*, and since it is the farthest removed from the elastic and pliable forms it is naturally given the lowest rating by the "inspection test."

A study of this peculiar property has been made by the author.<sup>1</sup> It was first observed that the moisture content of all crazed samples had dropped to an unusually low value, averaging about 11 per cent. Samples of the same lots that had been stored under different conditions, and had not been exposed to the warm dry air with which the crazed samples had been brought in contact, were still firm, and on test were found to average about 15 per cent water. These were in turn placed in a dryer and warmer atmosphere and the water content noted at the point when crazing first became manifest. This was found to lie at about 11.5 per cent water. The maximum difference in the water content at this point was less than 0.4 per cent. The water content is therefore shown to be an important factor in crazing, for it seems that just as soon as this value reaches a certain minimum amount, the low grade glue will craze.

But many glues that are of the same viscosity and jelly strength, as determined by the usual means, will not become crazed when exposed to the same conditions as those above described. Their moisture content, when they have reached equilibrium with the air, is higher than 11.5 per cent. In an attempt to find out exactly wherein lay the differences between these two types that one should be able to retain more water under any given conditions than the other, a number of samples of both types were first examined for their content of ash, nitrogen, and organic matter. These data not furnishing any results of value, the glues were examined for protein, proteose, peptone, and amino-acid.<sup>2</sup> It was found that the crazed samples contained less protein, and more proteose and peptone than the firm samples. The averages showed the following distribution of the nitrogen:

<sup>1</sup> R. H. BOGUE, *Chem. Met. Eng.*, **23** (1920), 154.

<sup>2</sup> See pages 25 to 28.

	Protein N	Proteose N	Peptone N	Amino-acid N
Crazed samples...	38.9	46.2	12.8	2.1
Firm samples....	42.3	44.6	11.0	2.1

The ordinary test, it was stated, showed the same for the two sets of samples, but it has been shown that the jelly consistency and the viscosity are, under similar conditions, proportional to the protein content. The above data would signify, therefore, that these tests should be higher in the case of the firm samples. The reasons why they are not found to be higher lie in the indelicacy of the tests by which they are determined. The differences even between the tests for pure water and these very low grade glues is hardly appreciable, but by the use of more refined instruments the author has been able to show that just as the viscosity of water and a weak glue is really very different, so also is that of the above crazed and firm glues under identical conditions. The data indicate that the firm samples should have the higher test, and this is found to be the case when appropriately measured.

Crazing in glues is therefore found to be due to an exceptionally great hydrolysis of the protein molecule, and the consequent inability of the resulting mixture to retain water above that minimum content below which crazing may occur. The customary rating of a crazed glue as an inferior product, by the inspection test, is accordingly shown to be correct in principle from the standpoint of evaluation by either the protein content or the usual tests of jelly consistency and viscosity, provided the latter are made by sufficiently sensitive instruments.

## CHAPTER IX

### THE CHEMICAL ANALYSIS, DETECTION, AND ESTIMATION OF GELATIN AND GLUE

There are agents in Nature able to make the particles of bodies stick together by very strong attractions. And it is the business of experimental philosophy to find them out.

Isaac Newton (1700)

	PAGE
I. The Chemical Analysis of Gelatin and Glue.....	427
1. The Sampling.....	427
2. Proximate Analysis.....	429
3. Ash Analysis.....	433
4. The Organic Analysis of Gelatin.....	448
5. Further Analytical Tests.....	450
6. Traces of Metals in Gelatin.....	456
II. The Estimation of Gelatin in Commercial Gelatin and Glue.....	463
1. Alcoholic Precipitation.....	463
2. Tannin Precipitation.....	464
3. Picric Acid Precipitation.....	466
4. Indirect Methods.....	467
5. Salt Precipitation.....	468
III. The Detection and Estimation of Gelatin and Glue in Foods and Miscellaneous Products.....	470
1. Gelatin in Meat and Meat Products.....	470
2. Gelatin in Milk, Cream, and Ice Cream.....	477
3. Gelatin in Other Food Products.....	478
4. Glue in Size and Miscellaneous Preparations.....	483

A chemical examination of gelatin and glue may be of value and very necessary for a number of purposes. In any kind of research dealing with these substances it is very desirable that as complete a knowledge as may be practicable of the chemical composition should be obtained. From the nature of the material, commercial gelatin cannot be regarded as a pure chemical compound. It may contain much ash or little, and not only the amount but the composition of the ash may be of vital importance in determining the properties of the product. The material may consist essentially of the unhydrolyzed protein, or it may be largely in the form of proteoses, peptones, and even amino-acids. A determination of the relative amounts of each of these

nitrogenous constituents present should be of the greatest value in any study of physico-chemical relationships, and has already thrown much light upon the chemical causes for variations in physical properties.

The determination of the hydrogen-ion concentration is, in the opinion of the author, one of the most important of the later contributions to the physico-chemistry of gelatin. By means of this simple test the position of the specimen at hand in the curves for swelling, viscosity, jelly consistency, and joint strength may be ascertained, and information obtained as to whether the sample has reached its maximum for these properties, and, if not, the exact treatment necessary to bring this desirable change about is indicated.<sup>1</sup> The applications of this new test are still in the period of infancy, but much is expected of them. In fact we may already go so far as to affirm that the properties of a gelatin or glue, including those mentioned above which are ordinarily used as a basis for grade, are adequately defined by three factors: First, the concentration of the unhydrolyzed protein gelatin in the sample; second, the hydrogen-ion concentration; and third, the nature and amount of inorganic salts present. With any given values for these three factors, all other variables will be found to approach to definite and precisely allocated terms. The action of salts, the degree of dispersion, the solvation, are all functions of the ionization, and the ionization is shown to bear a definite relation to hydrogen-ion concentration.

The application of chemical methods of examination to control work in laboratories, or to the commercial evaluation of gelatin or glue, is probably limited. The hydrogen-ion concentration test will undoubtedly find employment. Occasionally the chemical test for fat is used, and moisture is often determined. The various tests for acids are sometimes used. But in general it seems that the physical tests are of sufficient accuracy, and are so much more easily made, and require a so much lesser degree of skill and chemical intelligence, that they are not likely to be superseded by chemical tests.<sup>2</sup>

The requirements of the Federal and State Pure Food Laws make it necessary that gelatin for use as a food or in medicinal preparations shall be practically free of all substances of a

<sup>1</sup> See Chap. X for a further treatment of this subject.

<sup>2</sup> The evaluation of gelatin and glue is considered in Chap. X.



poisonous, or in any sense harmful, nature. Such products should accordingly be tested for sulphur dioxide, arsenic, copper, zinc, tin, and lead, as well as for acidity or alkalinity and occasionally other specific substances, in addition to some test that will indicate the actual amount of unhydrolyzed gelatin present.

The use of gelatin or glue in foods and in numerous commercial preparations makes it necessary that methods be developed by which the presence of this animal product may be accurately indicated and estimated when present only in small quantities and in the presence of other proteins or somewhat similar substances. Gelatin often finds its way into meat extracts, cream, ice cream, and fruit products, and occasionally into chocolate, coffee, etc. Glue may be present in a hundred or more technical preparations, as pastes, paints, size, calsumine, printers' rollers, fillers, etc., etc.

An attempt is made in the present chapter to present, therefore, not only the inorganic and organic methods of analysis, but the tests which may be employed in testing for gelatin and glue in various preparations.

## I. THE CHEMICAL ANALYSIS OF GELATIN AND GLUE

The chemical examination of a gelatin or glue is commonly separated into an analysis of organic and of inorganic constituents. For some purposes it suffices to determine only the moisture, ash, organic matter, and nitrogen. Such an examination is spoken of as a *proximate analysis*. It is sometimes desirable to know the complete mineral content of the material, in which case the ash is further examined by the methods of quantitative inorganic analysis. The presence of even traces of arsenic, lead, copper, etc., is impermissible in edible gelatin, and special tests may be made for these constituents. It is oftentimes essential that the nature of the organic material of the gelatin or glue should be ascertained, and various methods may be employed for making appropriate determinations.

**1. The Sampling.**—Whenever a glue is delivered in carload lots, or in barrels by the carload, it is inevitable that the glues will vary in different parts of the shipment. There are several reasons for this. In the first place the glue obtained from a single boiling of a single kettle would be insufficient to fill the order, and consequently boilings taken from a number of different

kettles of the same stock, or of different stocks that happen to give particular tests, such as jelly consistency or viscosity, that are identical, are mixed or packed separately, and constitute the single shipment. The similarity of any given physical test in two or more lots of glue cannot be taken as an indication that any other tests are likewise similar, and the chemical analysis might show very different results in the several cases.

Whenever two or more lots of glues are mixed and the mixture ground there is always a tendency for the finer or heavier flakes to sift down toward the bottom of the barrel, while the larger or lighter flakes remain at the top. Unless the flakes of the mixture are of exactly the same size and density there will be a separation of the component glues in the barrel, the top being richer in the larger lighter component, the bottom being richer in the finer heavier type.

A third cause for variation in different parts of the shipment is found in the readiness with which glue and gelatin absorb moisture from the air when the latter is of high humidity, and give off the moisture when the humidity falls. The glue and gelatin act indeed as a hygrometer, and there is a definite water content of any given specimen at equilibrium at any given temperature and humidity. The author<sup>1</sup> has shown that a low grade glue that will craze badly when allowed to stand for a few days in a cabinet of samples in an office will be, however, perfectly firm in the barrels, stored in a cooler and moister place. The difference in moisture content was as much as 6 per cent. It is obvious that the glue at the center of a barrel will have less contact with the external air and so less opportunity for fluctuation in moisture content than the exterior portions. For this reason wide variations have been observed at different portions of the barrel.

For a perfectly representative sample it would be best to thoroughly mix the entire shipment before sampling, but this procedure is not usually possible. Portions of a pound each may be taken from various parts of the barrels, and on account of the possible shipment of more than one lot, each barrel should receive a separate inspection. The several portions removed from a barrel are then thoroughly mixed, and a portion of about a pound taken from different parts of this lot and ground in a small mill (a coffee mill works well for the purpose) to as fine a

<sup>1</sup> R. H. BOGUE, *Chem. Met. Eng.*, **23** (1920), 154.

flake as possible. This is then placed in a tight glass-stoppered bottle, from which all future samples for analysis or test should be taken.

**2. The Proximate Analysis.**—The proximate analysis consists of a determination of the moisture, organic matter, ash, and nitrogen. The moisture, organic matter, and ash taken together give data that are often very useful. Other conditions being equal, the moisture content is found to vary directly as the protein content of the substance, and is thus an indication of that important factor. A high ash figure usually signifies the addition of some inorganic material, which may have been introduced as a clarifying agent, or a filler, or for a number of other reasons. The nitrogen figure is not of great importance for the greatest diversity of glues and gelatins have been shown<sup>1</sup> to contain almost identical amounts of nitrogen. It is no indication of the true protein present, for the hydrolyzed proteose and peptone as well as amino-acids are all included in the one figure. The practice therefore of multiplying the nitrogen value by a factor to obtain the protein content is unsound and misleading as far as glues are concerned.

*Moisture.*—A 5 or 10 gram sample of the finely ground glue is placed in a tared aluminium or tin dish of about 3 inches in diameter, and placed in an electric oven at 110–115°C., or a vacuum oven at 80°C., and allowed to remain until the weight is constant. Not less than 12 hours in the former and 6 hours in the latter case should be allotted for the expulsion of all of the moisture, and if the flake of the glue is coarse or thick a longer time may be necessary. The loss in weight sustained by the sample is moisture. At a medium degree of humidity the moisture content of glues will vary from about 10 to 11 per cent in the lowest to about 15 to 16 per cent in the highest grades, but under conditions of high humidity a low grade glue may run as high as 17 per cent moisture, while under very dry conditions a high grade of glue may show as little as 12 per cent moisture.

*Ash.*—A sample weighing from 3 to 5 grams, or the residue left from the moisture determination, provided the amount taken for the latter was not over 5 grams, is placed in a quartz or porcelain crucible. Platinum may be used with safety only when the absence of phosphorus is assured, as a slight reduction of the phosphates may result in a corrosion of the platinum

<sup>1</sup> R. H. BOGUE, *Chem. Met. Eng.*, **23** (1920), 105.



crucible. The crucible is heated very slowly over a bunsen burner until the moisture is completely expelled, care being taken that the glue is not heated so high that the particles explode upon the escape of steam. The temperature is raised slowly, not permitting the mass to catch fire, until the gases have escaped. A slow incineration is then brought about by the application of a low flame for several hours, or preferably by placing the crucible in a muffle furnace. Too high a temperature must be avoided as a graphite-like carbonaceous residue may be formed which is oxidized exceedingly slowly. A high temperature is also likely to result in a reduction of the phosphates and a volatilization of alkali chlorides. If the ash is rich in silica, as in glues that have been clarified with sodium silicate, or in phosphates from the solution of too much of the bone during boiling, or the use of an excessive amount of phosphoric acid in the manufacturing process, the carbon may not burn off at the low temperature necessary. In this case, char the material, treat with water or dilute acetic acid to dissolve the soluble salts, filter through an ashless filter, dry the paper and incinerate. When free of carbon add the filtrate to the incinerated residue, evaporate to dryness, and ignite at a low temperature. Place in a desiccator until cool, and weigh. The residue is recorded as ash. This should then be intimately mixed and preserved in a tightly stoppered bottle for use in the ash analysis, to be described later.

This product should be white, or slightly reddish due to the presence of oxides of iron, but entirely free from black particles of carbon. It may be easily fusible, due to the presence of phosphates of calcium and magnesium, or it may be quite infusible at the temperatures employed. It has often been stated that the fusibility of the ash served as an indication of the origin of the material, the ash from the bone glues fusing, since they contain phosphates, and that from the hide glues not fusing as they did not contain phosphates. At the present time, however, phosphoric acid is often added in part to neutralize the lime used in swelling hide stock, and so finds its way into this product in as great amount as it exists in bone glues. This means of distinguishing between the two types is therefore not permissible today. On the other hand, both hide and bone glues may be incinerated and the ash obtained in an unfused condition if especial care is taken in keeping the temperature low.

The ash content of glues varies from about 1 to 5 per cent



where no inorganic material has been added directly to the glue. Where such additions have been made, as in colored glues, the ash content may rise to 10 or 15 per cent.

*Organic Matter.*—The organic matter is estimated by subtracting the sum of the percentages of the moisture and the ash present from 100. On the basis of dry moisture-free glue, the organic matter does not vary materially on passing from a high to a low grade glue, but since the moisture content has been shown to vary with the grade, the organic matter, calculated on the basis of the ordinary glue, is found to be actually lower in the high grades than it is in the low grades. The total content of organic matter in the glue is obviously not of critical importance in the determination of grade.

*Nitrogen.*—The total nitrogen of gelatin or glue is best determined by a modification of the Kjeldahl process. One gram samples are weighed out and placed in Kjeldahl digestion flasks, of Pyrex or other acid-resistant make, of 800 c.c. capacity. About 10 grams of potassium sulphate and a small crystal of copper sulphate the size of a pin head are added. Fifteen to twenty c.c. of pure concentrated sulphuric acid are then poured down the side of the flask, and the contents shaken gently that the glue may be disseminated throughout the acid. If a lump is left adhering to the glass the flask may crack on applying heat. It has been found very advantageous also to introduce into the flask a few small crystals, the size of a pin head, of garnet or carborundum. These prevent a bumping of the flask during the digestion and distillation. The flask is then placed in an inclined position, resting upon a circular opening in an asbestos board, with the neck introduced into a pipe from which the sulphur trioxide fumes are exhausted by a good draught, but open at the lower end that the condensed water and acid may drain out into a receiver. If no good chimney or fan draught is available, very satisfactory results may be obtained by using a 1½ inch lead pipe, closed at its upper end, and emptying into water at the lower end. In this case the connections with the flasks are made through ⅛ inch lead tubes introduced into the larger tube at convenient intervals, and tight joints secured with rubber stoppers.<sup>1</sup>

A low flame is introduced below the flask and watched carefully until the first excessive foaming has subsided. A higher

<sup>1</sup> Cf. F. G. MERKLE, *J. Ind. Eng. Chem.*, 8 (1916), 521.

temperature is then applied, and continued until the contents have assumed a clear light blue or colorless appearance. No trace of brown or amber color should remain. This will take from 3 to 6 hours. The flame is then extinguished and the flask left undisturbed until the contents have cooled. Not until the bottom of the flask may be held in the hand without burning should the next step be taken.

About 400 c.c. of cold water are added to the contents of the cooled flask, followed by a sufficient amount of saturated sodium hydroxide to render the contents distinctly alkaline. This may conveniently be ascertained by adding a drop of methyl-red indicator solution, which is yellow in alkaline but red in acid solution. In the event that this red color gives place to yellow at any time during the subsequent distillation, more alkali must be added. The flask is at once connected with a condenser, the lower end of which dips into a flask containing 25 c.c. of a standard solution of N/2 hydrochloric acid, to which 2 or 3 drops of methyl-red indicator have been added. Heat is again applied to the flask, and about 100 c.c. distilled over.

The distillate is titrated against a standard solution of N/2 sodium hydroxide. The difference in the volume of standard acid used and standard alkali necessary to complete the titration represents the volume of N/2 acid necessary to neutralize the nitrogen, in the form of ammonia, which was contained in the sample. Since 1 c.c. of N/2 acid will neutralize 0.007 gram of nitrogen as ammonia, then the volume of acid required, multiplied by 0.007, and the product divided by the weight of sample taken, will give, on multiplying by 100, the percentage of nitrogen in the sample, or

$$\frac{\text{Vol. N/2 HCl} \times 0.007 \times 100}{\text{weight of sample}} = \text{per cent N.}$$

The practice of multiplying the nitrogen value by a factor, as 6.25 or 6.56, which has often been suggested as a means for the estimation of the protein gelatin in the sample is without justification except the sample be known to be pure gelatin. By such a procedure a low grade glue is shown to possess nearly the same percentage of protein as a high grade gelatin, and this has been shown by the author<sup>1</sup> to be altogether contrary to the facts.

<sup>1</sup> R. H. BOGUE, *Chem. Met. Eng.*, **23** (1920), 107.

The nitrogen content of glues and gelatins varies but little, but on a moisture-free basis is slightly higher in the better grades than in the lower grades. It runs from 14 to 15 per cent on the moisture-present basis, and 16 to 18 per cent on the moisture-free basis.

On account of the constancy of the nitrogen content of all glues, the determination is not of great value in ordinary work. But the determination has been the best means for detecting adulteration of glue or gelatin with certain foreign substances, as dextrines, starches, dextrose, glycerin, etc. These substances, being non-nitrogenous, depress greatly the nitrogen content of the material. Such adulteration is easily distinguished from the excessive use of a "filler," as the latter will be evident by an ash analysis. But if the nitrogen content of the organic material of the glue drops below its customary value, adulteration as above is indicated. The addition of nitrogenous adulterants as casein, blood albumin, etc., could not pass unobserved on account of their special properties, as coagulation on heating, etc.

Several determinations for the nitrogen content of water-free gelatin are given below:

MÜLDER, <i>Ann.</i> , <b>45</b> (1843), 63.....	18.3
SCHÜTZENBERGER and BOURGEOIS, <i>Jahresber. Tierchem.</i> (1876), 30...	18.3
CHITTENDEN and SOLLEY, <i>J. Physiol.</i> , <b>12</b> (1891), 33.....	18.0
PAAL, <i>Ber.</i> , <b>25</b> (1892), 1202.....	18.12
VAN NAME, <i>J. Exptl. Med.</i> , <b>2</b> (1897), 117.....	17.81
SAKIDOFF, <i>Z. physiol. Chem.</i> , <b>37</b> (1903), 397. (Kjeldahl).....	17.47
(Dumas).....	18.18
HALLA, <i>Z. angew. Chem.</i> , <b>20</b> (1907), 24.....	17.61
BOGUE, <i>Chem. Met. Eng.</i> , <b>23</b> (1920), 105. (Kjeldahl).....	17.50
SMITH, <i>J. Am. Chem. Soc.</i> , <b>43</b> (1921), 1350.....	17.53

**3. The Ash Analysis.**—A complete ash analysis of glues and gelatins should include determinations for the following inorganic components:

Silica.....	SiO <sub>2</sub>
Ferric oxide.....	Fe <sub>2</sub> O <sub>3</sub>
Lime.....	CaO
Magnesia.....	MgO
Potash and soda.....	K <sub>2</sub> O and Na <sub>2</sub> O
Sulphate.....	SO <sub>3</sub>
Phosphate.....	P <sub>2</sub> O <sub>5</sub>
Chloride.....	Cl

The above list includes all of the inorganic radicals that are apt to be present in a glue or gelatin to which foreign substances have not been added. Many substances may be added, however, as zinc oxide, calcium carbonate, or lead sulphate, to produce a white opaque glue, alum for clarifying the material or to produce abnormal viscosities, barium hydroxide for neutralizing acidity, and at times various other salts or pigments for special purposes, as, for example, potassium dichromate for producing insolubility. That this discussion may be as complete as is consistently practicable, the following radicals will be added to those given above in the analytical procedures outlined below:

Zinc oxide .....	ZnO
Alumina .....	Al <sub>2</sub> O <sub>3</sub>
Barium oxide.....	BaO
Lead oxide.....	PbO

The analyses in table 48 are typical of glues and gelatins.

*Silica.*<sup>1</sup>—Five grams of the dry and intimately mixed ash are weighed into a small evaporating dish, 10 c.c. of dilute hydrochloric acid are added, and the mixture evaporated to dryness and heated gently to render the silica insoluble. Ten c.c. of hydrochloric acid are again added and 50 c.c. of water introduced. The dish is warmed on the water bath for a few minutes and the contents filtered through an ashless filter and washed till free of chloride. The combined filtrate and washings are made up to 250 c.c. in a volumetric flask and reserved for further determinations. This solution will be designated as "Solution A." The residue on the filter paper is now dried and ignited, and after cooling in a desiccator, weighed as SiO<sub>2</sub>.

$$\frac{\text{Weight SiO}_2 \times 100}{5} = \text{Per cent SiO}_2.$$

*Phosphoric Acid.*<sup>2</sup>—Twenty-five cubic centimeters of solution A are pipetted into a 250 c.c. beaker. If ferrous iron is present, add a few c.c. of concentrated nitric acid or hydrogen peroxide and boil for a few minutes. Cool and add ammonium hydroxide until a precipitate just forms, then a few drops of nitric acid to clear, and 2 to 3 c.c. of concentrated nitric acid in excess. Now add 25 c.c. of 50 per cent ammonium nitrate solution, warm to

<sup>1</sup> Association of Official Agricultural Chemists, "Methods of Analysis" (1920), 15.

<sup>2</sup> A. O. A. C., *op. cit.*, 18.



TABLE 48.—THE INORGANIC COMPOSITION OF GELATINS AND GLUES

	Gelatin (Bogue) <sup>1</sup>	High grade hide glue (Tressler) <sup>2</sup>	High grade hide glue (Shuey) <sup>3</sup>	Inferior hide glue (Shuey) <sup>3</sup>	Colored hide glue (Hayes) <sup>4</sup>	Bone glue (Bogue) <sup>1</sup>	Glue from fish sound clarified (Tressler) <sup>2</sup>	Liquid fish glue clarified (Tressler) <sup>2</sup>
Moisture.....	16.02	13.20	.....	.....	16.70	13.40	55.50	49.70
Organic matter.....	81.53	82.00	.....	.....	75.85	81.75	40.31	49.34
Ash.....	2.45	4.80	1.93	4.46	3.45	4.85	4.19	0.96
SiO <sub>2</sub> *.....	1.8	3.3	.....	.....	2.6	3.1	24.6	12.7
Fe <sub>2</sub> O <sub>3</sub> , Al <sub>2</sub> O <sub>3</sub> .....	0.3	trace	.....	.....	.....	1.4	trace	trace
CaO.....	51.1	54.0	49.5	41.3	27.9	52.6	5.6	10.5
MgO.....	trace	trace	.....	.....	4.7	trace	trace	trace
ZnO.....	.....	.....	.....	.....	29.3	.....	.....	13.9
K <sub>2</sub> O, Na <sub>2</sub> O.....	5.4	7.6	.....	.....	2.0	3.1	30.0	.....
SO <sub>3</sub> .....	24.8	36.0	25.9	8.0	7.0	12.5	16.5	34.0
P <sub>2</sub> O <sub>5</sub> .....	2.4	trace	2.2	19.0	5.4	14.4	0.13	24.9
Cl.....	6.1	trace	8.1	27.2	2.9	6.2	23.5	3.2
CO <sub>2</sub> .....	8.1	.....	.....	.....	18.2	6.7	.....	.....

\* The ash constituents are expressed as percentage of total ash.

<sup>1</sup> R. H. BOGUE, unpublished (CO<sub>2</sub> by difference).

<sup>2</sup> D. TRESSLER, personal communication.

<sup>3</sup> R. C. SHUEY, monograph (1912).

<sup>4</sup> S. D. HAYES, cited by DAWIDOWSKY, "Glue, Gelatin, etc.," Philadelphia (1905), 207.

40°C., and add slowly with constant stirring an excess of molybdate solution (prepared as directed below), and allow to stand for an hour at a warm temperature. Ascertain if an excess of the molybdate solution has been added by adding a few c.c. of the latter to a clear portion of the solution. In case a precipitate forms more molybdate solution must be added. The solution is allowed to stand in a warm place over night, then filtered, and washed with about 75 c.c. of a 2.5 per cent ammonium nitrate solution. The combined filtrate and washings are retained for other determinations, and designated as "Solution B." The precipitate is dissolved on the filter by pouring through it successive small portions of ammonium hydroxide and hot water. The solution which should not exceed 100 c.c. is collected in a beaker and nearly neutralized with hydrochloric acid. After cooling, magnesia mixture (see below) is added very slowly from a burette, stirring constantly. After some minutes 12 c.c. of ammonium hydroxide (sp. gr. 0.90) are added. The beaker is set aside until the supernatant liquid is clear (about 2 hours). The precipitate is then filtered through an ashless filter, washed with dilute ammonium hydroxide till free of chloride, and dried. The residue is separated from the filter paper, and the latter ignited in a weighed porcelain crucible. The precipitate is then added, and the crucible heated to a dull redness. It is cooled, and the phosphorus weighed as  $Mg_2P_2O_7$ . This is calculated to  $P_2O_5$ .

$$\frac{\text{Weight } Mg_2P_2O_7 \times 0.638 \times 100}{0.5} = \text{per cent } P_2O_5.$$

The volumetric method of titrating the phospho-molybdate precipitate with standard alkali may be used if desired. A 10 gram sample of glue is incinerated in a porcelain dish, cooled, and 2 c.c. of concentrated hydrochloric acid and 5 c.c. of concentrated nitric acid added. This is evaporated to dryness and the residue heated to a dull red heat or until perfectly white. The residue is dissolved in 5 c.c. of hot concentrated nitric acid, boiled, and filtered, the filter being washed with hot water. The filtrate is treated with ammonium hydroxide until a precipitate just forms, this is dispelled with a few drops of nitric acid, and the solution warmed to about 85°C. Twenty-five to 50 c.c. of ammonium molybdate solution are then added, or an amount sufficient to completely precipitate the phosphate. The solution is allowed to stand for at least 15 minutes, and is then filtered through a Gooch crucible, and the precipitate washed with water until two fillings of the filter do not appreciably decrease the color produced by 1 drop of standard sodium hydroxide and 3 drops of phenolphthalein. The filter and precipitate are then returned to the precipitating flask, and a measured quantity of standard solution of N/10 alkali added (at least enough to dis-

charge the yellow color and dissolve the precipitate). A few drops of phenolphthalein are added and the mixture titrated back with standard N/10 acid. The reaction involved is:

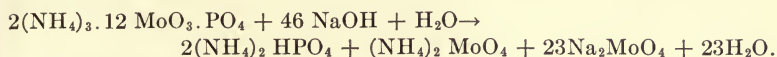

Hence 46NaOH are equivalent to  $1\text{P}_2\text{O}_5$ , or 1 c.c. of N/10.NaOH is equivalent to 0.000309 $\text{P}_2\text{O}_5$ .

$$\frac{\text{C.c. NaOH} \times 0.000309 \times 100}{10} = \text{per cent } \text{P}_2\text{O}_5.$$

*Reagents Used in Phosphate Determinations. Molybdate Solution.*—One hundred grams of molybdic acid are dissolved in dilute ammonium hydroxide (144 c.c. of concentrated ammonium hydroxide + 271 c.c. of water). This solution is poured slowly, stirring constantly, into dilute nitric acid (489 c.c. of concentrated nitric acid + 1148 c.c. of water). The mixture is allowed to stand in a warm place for several days, or until a portion heated to 40°C. deposits no yellow precipitate of ammonium phosphomolybdate. The solution is decanted and preserved in glass-stoppered vessels.

*Magnesia Mixture.*—Twenty-two grams of recently ignited magnesium oxide are dissolved in dilute hydrochloric acid, avoiding an excess. The magnesia is added in slight excess and boiled. Any iron, aluminium or phosphoric acid precipitated is filtered off. Two hundred and eighty grams of ammonium chloride and 261 c.c. of concentrated ammonium hydroxide are added and the whole diluted to 2 liters. In place of the 22 grams of calcined magnesia, 110 grams of crystallized magnesium chloride ( $\text{MgCl}_2.6\text{H}_2\text{O}$ ) dissolved in water may be used, and the other reagents added as above.

*Phosphoric Acid in Leach Liquors.*—A very convenient method for the determination of the form of combination of  $\text{P}_2\text{O}_5$  in leach liquors has been developed by Shuey<sup>1</sup> as follows:

As the titration of a polybasic weak acid does not follow the commonly accepted rules of titration, volumetric determination of  $\text{P}_2\text{O}_5$  is not considered possible. Probably to obtain extremely accurate results by a volumetric method would require more care and time than a gravimetric determination, but for rough factory control a method has been worked out which has given the necessary accuracy.

If a known  $\text{H}_3\text{PO}_4$  solution is titrated with a standard NaOH solution, using methyl orange as an indicator, the neutral point of the indicator is reached at the equilibrium  $\text{H}_3\text{PO}_4 + \text{NaOH} = \text{NaH}_2\text{PO}_4 + \text{H}_2\text{O}$ .

<sup>1</sup> R. C. SHUEY, personal communication.

If phenolphthalein is then added and titration continued until the development of a rose color the equilibrium will stand  $\text{H}_3\text{PO}_4 + \text{NaOH} = \text{Na}_2\text{HPO}_4 + 2\text{H}_2\text{O}$ .

These reactions apply to the soluble salts of phosphoric acid either direct or dissolved in known quantities of HCl. If, however, a calcium salt is dissolved in known HCl and titrated with  $\text{Ca}(\text{OH})_2$  for example, the difference in titration between the two end points is equivalent to two-thirds of the phosphate present in place of one-third as above. In fact the titrations give more accurately the  $\text{P}_2\text{O}_5$  content of the solution than the regular titrations of the pure acid in the absence of calcium.  $\text{Ca}(\text{H}_2\text{PO}_4)_2 + 2\text{Ca}(\text{OH})_2 = \text{Ca}_3(\text{PO}_4)_2 + 4\text{H}_2\text{O}$ .

Also, in the presence of high calcium, it was observed that precipitation commences at the exact point of neutralization of the first third of the  $\text{P}_2\text{O}_5$  and is a sharper indicator than the methyl orange itself. That is, at this point, due to hydrolysis, a precipitate of  $\text{CaHPO}_4$  forms, and can be used as a check indicator, of the end point of formation of  $\text{Ca}(\text{H}_2\text{PO}_4)_2$ .

If to a known phosphoric acid an excess of carefully neutralized calcium chloride is added and titration made with NaOH, we produce a combined condition. In the first case it was titration of free acid with sodium. In the second case, with calcium. In this case it is titration of free acid with sodium in the presence of calcium.

The methyl orange neutral point is normal and coincident with the above appearance of precipitate. If phenolphthalein is then added and titration continued, a transitory color change will appear at the two-thirds point, and will not become permanent until sufficient NaOH has been added to neutralize all the acid. This indicates that although the precipitate first formed is  $\text{CaHPO}_4$  it rapidly changes to  $\text{Ca}_3(\text{PO}_4)_2$ , and is completely changed over by the time the color has become permanent.

Experiments based upon the above observations were used in working out the following procedure, which is applicable to the determination of soluble sodium and calcium salts of phosphoric acid either alone or mixed with each other, and the free acid or the corresponding bases, all in a single sample of solution.

A 10 c.c. sample is taken and half normal NaOH and HCl are used in the titration. A 50 per cent solution of calcium chloride is made up, and adjusted to exact neutrality of phenolphthalein.

Phenolphthalein is added to the sample; if it does not turn pink methyl orange is added; if this also shows acid, titrate with standard alkali until the orange is almost gone. Four drops more should show a pure yellow. If there is considerable calcium present a permanent precipitate will form at this point, and the change to yellow will not be as sharp. This titration shows one-third of the free acid.  $\text{H}_3\text{PO}_4 + \text{NaOH} = \text{NaH}_2\text{PO}_4 + \text{H}_2\text{O}$ .

Titration to the neutral point of phenolphthalein is then commenced, adding about 50 c.c. of water if considerable precipitate is formed. The products from the former titration again react, the three possible reactions being:

1. If there was free acid:  $\text{NaH}_2\text{PO}_4 + \text{NaOH} = \text{Na}_2\text{HPO}_4 + \text{H}_2\text{O}$ , again giving  $\frac{1}{3}$  the acid;



2. If there was mono-sodium phosphate:  $\text{NaH}_2\text{PO}_4 + \text{NaOH} = \text{Na}_2\text{HPO}_4 + \text{H}_2\text{O}$ , giving  $\frac{1}{3}$  the mono-sodium salt;

3. If there was mono-calcium phosphate:  $3\text{Ca}(\text{H}_2\text{PO}_4)_2 + 8\text{NaOH} = 4\text{Na}_2\text{HPO}_4 + \text{Ca}_3(\text{PO}_4)_2 + 8\text{H}_2\text{O}$ , giving  $\frac{1}{3}$  of the mono-calcium salt.

As before indicated, this is made possible by the calcium being replaced by sodium which again is titrated.

When an excess of neutral calcium chloride is added, all three of the above reactions having produced  $\text{Na}_2\text{HPO}_4$ , this is now converted, we will say: (1), (2) and (3):  $\text{Na}_2\text{HPO}_4 + \text{CaCl}_2 = \text{CaHPO}_4 + 2\text{NaCl}$ , and titration continued. (1), (2) and (3):  $2\text{CaHPO}_4 + 2\text{NaOH} + \text{CaCl}_2 = \text{Ca}_3(\text{PO}_4)_2 + 2\text{H}_2\text{O} + 2\text{NaCl}$ , again giving one-third the acid and one-third the mono-sodium salt originally present but  $\frac{2}{3}$  of the mono-calcium phosphate, for we have titrated the final  $\frac{1}{6}$  of the  $\text{P}_2\text{O}_5$  in reactions (3).

*Calculation.*—Using the symbols M. O. for the methyl orange titration, Ph for the first phenolphthalein titration, and CaPh for the final titration in excess of calcium, and having in mind that all readings are taken from zero:

$$\text{M. O.} \times 0.355 = \text{per cent } \text{P}_2\text{O}_5 \text{ existing as free acid.}$$

$$\text{Ph} = \text{Free Acid} + \text{Sodium} + \frac{1}{3} \text{Calcium.}$$

$$\text{CaPh} = \text{Free Acid} + \text{Sodium} + \frac{1}{3} \text{Calcium.}$$

Solving these two equations for sodium we get:

$$(\text{CaPh} - 3\text{Ph}) \times 0.355 = \text{P}_2\text{O}_5 \text{ combined with Na.}$$

Solving for calcium we get:

$$\frac{3}{2}(2\text{Ph} - \text{M. O.} - \text{CaPh}) \times 0.355 = \text{P}_2\text{O}_5 \text{ combined with Ca.}$$

Also

$$\frac{\text{CaPh} - \text{M. O.}}{2} \text{ (all from monobasic to tribasic)} \times 0.355 = \text{total } \text{P}_2\text{O}_5.$$

If, however, the original sample shows acid to phenolphthalein and alkaline to methyl orange it can contain only  $\text{Ca}(\text{H}_2\text{PO}_4)_2$  and  $\text{NaH}_2\text{PO}_4$ . In this case titrate back to the neutral point of methyl orange with acid and M. O. (acid)  $\times 0.355 = \text{P}_2\text{O}_5$  of  $\text{Na}_2\text{HPO}_4$ . We now have all monobasic salts and the reasoning of the former example applies, except that the alkali readings, of course, start from the M. O. neutrality point, therefore:

$$2\text{CaPh} - 3\text{Ph} \times 0.355 = \text{P}_2\text{O}_5 \text{ combined with Na.}$$

$$\frac{3}{2}(2\text{Ph} - \text{CaPh}) \times 0.355 = \text{P}_2\text{O}_5 \text{ combined with Ca.}$$

$$\text{Also } (2\text{CaPh} - 3\text{Ph} - \text{M. O.}) \times 0.355 = \text{P}_2\text{O}_5 \text{ combined as } \text{NaH}_2\text{PO}_4,$$

$$\text{and } \frac{\text{CaPh} \times 0.355}{2} = \text{total } \text{P}_2\text{O}_5.$$

If the original sample shows alkaline to phenolphthalein, the original sample, if sodium is absent, will contain only  $\text{Ca}(\text{OH})_2$ . If sodium is present, it may exist as  $\text{Na}_2\text{HPO}_4$  or  $\text{NaOH}$  and calcium cannot exist in solution to any appreciable extent. The acid required to reach the phenolphthalein end point represents  $\text{Na}_3\text{PO}_4 + \text{NaOH}$ .  $\text{CaCl}_2$  is then added in excess and the solution titrated with alkali. This value, if smaller than the previous titration, represents  $\text{Na}_3\text{PO}_4$ . If this value is larger than the previous titrations, no  $\text{NaOH}$  is present and it represents  $\text{Na}_3\text{PO}_4 + \text{Na}_2\text{HPO}_4$ .

If the solution is titrated back to neutrality to M. O., the value should be twice that of the CaPh titration, representing the total  $P_2O_5$ . For calculations, then using only values of — sign, Ph (acid) — CaPh (alk.)  $\times 0.355 = NaOH$  (ref. as  $P_2O_5$  for comparison).

$$CaPh \text{ (alk.)} \times 0.355 = P_2O_5 \text{ of } Na_3PO_4.$$

Or in the second case,

$$CaPh \text{ (alk.)} - Ph \text{ (acid)} \times 0.355 = P_2O_5 \text{ of } Na_2HPO_4.$$

$$Ph \text{ acid} \times 0.355 = P_2O_5 \text{ of } Na_3PO_4.$$

$$CaPh \text{ (alk.)} \times 0.355 = \text{total } P_2O_5.$$

$$\frac{M. O. \text{ (acid)}}{2} \times 0.355 = \text{total } P_2O_5.$$

In this calculation, all burette readings are independent.

An insoluble calcium salt of phosphoric acid may be dissolved in HCl and the total  $P_2O_5$  determined, but failure only attended attempts to work out a calcium determination which would show the partition between the two insoluble salts  $Ca_3(PO_4)_2$  and  $CaHPO_4$ .

The accuracy of this method is generally within 5 per cent of the total  $P_2O_5$ , but the error in the sodium-calcium position is multiplied in the calculations and is somewhat larger. As we are working in amphoteric solutions the end points are reached gradually and the highest accuracy is attained only by studying the exact color of the correct end points in solutions of known mixture. In working this out the titrations were made on known solutions of the different salts and the reactions are an attempt to explain the observations. Then the calculations were deduced and found to hold for known mixtures. It is evident that a method lacking accuracy has only limited applications, and the main object in presenting it, is that an idea of the composition of a solution can be gained in say five or ten minutes, and in the factory precipitation of phosphates, the supernatant liquor varies in composition so much more widely than the precipitate, that the composition of the precipitate from that liquor may be known with a much greater degree of accuracy.

*Ferric and Aluminum Oxide.*<sup>1</sup>—The whole of solution B is cautiously neutralized with ammonium hydroxide and a slight excess of the alkali added. The beaker is allowed to stand at 40°C. until the precipitate, which contains the iron and aluminum oxides, has completely settled. The clear supernatant liquid is then poured through a filter paper, and the precipitate washed a few times with hot water by decantation before transferring to the filter, and a few times on the filter. The precipitate is dissolved on the filter with hot dilute (1:5) nitric acid, collected in a 200 c.c. beaker, made up to about 90 c.c., and reprecipitated. It is filtered through the same filter paper and washed as before.

<sup>1</sup> A. O. A. C., *op. cit.*, 16.

The combined filtrates and washings from the two precipitations are reserved for subsequent determinations and designated as "solution C." The filter paper with its contents is dried and ignited, and weighed as  $\text{Fe}_2\text{O}_3 + \text{Al}_2\text{O}_3$ .

$$\frac{\text{Weight } \text{Fe}_2\text{O}_3 + \text{Al}_2\text{O}_3 \times 100}{0.5} = \text{per cent } \text{Fe}_2\text{O}_3 + \text{Al}_2\text{O}_3.$$

It is usually sufficient to determine and report the iron and aluminum oxides together, but if it is desired to separate them, the following procedure may be used. The residue of  $\text{Fe}_2\text{O}_3 + \text{Al}_2\text{O}_3$  is fused in a platinum crucible with about 4 grams of fused potassium hydrogen sulphate. Only a few minutes should be allowed for the fusion. After the crucible is cool, 5 c.c. of concentrated sulphuric acid are added and heat applied until sulphuric acid fumes are given off copiously. The crucible is again allowed to cool and is then transferred to a beaker of water and heated until the solution is clear. The iron is then reduced with zinc, the solution cooled, and titrated with N/50 potassium permanganate. Since  $2\text{KMnO}_4 = 5\text{Fe}_2\text{O}_3$ , 1 c.c. N/50  $\text{KMnO}_4 = 0.0016 \text{Fe}_2\text{O}_3$ . Therefore

$$\frac{\text{C.c. } \text{KMnO}_4 \times 0.0016 \times 100}{0.5} = \text{per cent } \text{Fe}_2\text{O}_3.$$

The difference between the percentage of  $\text{Fe}_2\text{O}_3 + \text{Al}_2\text{O}_3$  and of  $\text{Fe}_2\text{O}_3$  gives the percentage of  $\text{Al}_2\text{O}_3$ .

*Calcium Oxide.*<sup>1</sup>—For this determination either solution C or solution A may be used. If solution A is used, an aliquot of 25 c.c. (or more if desired, bearing in mind the amount taken for the calculation) is taken, and pure ferric chloride solution added in excess of that required to combine with the phosphoric acid, and ammonium hydroxide added until neutral. The precipitate is dissolved in a slight excess of hydrochloric acid, and 1–2 grams of sodium acetate added. After boiling for a few minutes it is filtered and washed with boiling water. The precipitate is dissolved in hydrochloric acid and reprecipitated as before.

The combined filtrates and washings from this treatment, or solution C taken as it is, are evaporated to about 50 c.c., made slightly alkaline with ammonium hydroxide, and while still hot, ammonium oxalate solution added very slowly in slight excess of the amount required to completely precipitate the calcium. The mixture is heated to boiling, the precipitate allowed to settle, and the clear solution decanted into a filter. The precipitate is washed in the beaker with 20 c.c. of hot water, and then

<sup>1</sup> A. O. A. C., *op. cit.*, 17.

dissolved with a few drops of hydrochloric acid. A little water is added and the precipitation repeated as before, filtering through the same paper. The precipitate is transferred completely to the filter, and washed with hot water till free of chlorides. It is then dried, ignited over a blast lamp to constant weight, and weighed as CaO. The filtrates and washings from the above precipitations are reserved for the magnesia determination, and designated as "solution D."

$$\frac{\text{Weight CaO} \times 100}{0.5} = \text{per cent CaO.}$$

The calcium may also be precipitated as the sulphate, converted into the oxalate, and the oxalic acid liberated and titrated against a permanganate. Ten grams of glue are incinerated in a porcelain dish, allowed to cool, and 2 c.c. of concentrated hydrochloric acid and 5 c.c. of concentrated nitric acid added. The solution is evaporated to dryness and again incinerated at a low red heat, or until white. The residue is dissolved in 2 c.c. of concentrated hydrochloric acid, filtered, and the filter thoroughly washed with hot water. The filtrate is evaporated to about 40 c.c. and while warm 10 c.c. of dilute (1:1) sulphuric acid added and then 150 c.c. of 95 per cent alcohol, and allowed to stand for 12 hours. The precipitate is then filtered off and washed with 70 to 75 per cent alcohol until free of sulphates, and dried. The precipitate is then washed from the filter to the original beaker, using a stream of hot water, and the paper replaced in the funnel, and thoroughly washed with boiling hydrochloric acid (1:5) and water. The filtrate is made slightly alkaline with ammonia, heated to boiling, and ammonium oxalate solution added in slight excess. The mixture is boiled for a few minutes, allowed to stand a half hour, then filtered and the precipitate washed with hot water. The paper is punctured and the calcium oxalate washed through into the precipitating beaker with 50 c.c. of boiling water. Twenty c.c. of dilute (1:1) sulphuric acid are then added and the oxalic acid liberated is titrated against a standard N/10 solution of potassium permanganate. When the end point is nearly reached the filter paper is also thrown into the beaker, and the titration finished. Since  $2\text{KMnO}_4$  are equivalent to  $5\text{CaC}_2\text{O}_4$ ,

$$\frac{\text{C.c. N/10 KMnO}_4 \times 0.0028 \times 100}{10} = \text{per cent CaO.}$$

*Magnesium Oxide.*<sup>1</sup>—Solution D is evaporated to dryness on a water bath and heated gently to expel ammonium salts. The residue is treated with about 25 c.c. of hot water and 5 c.c. of hydrochloric acid, filtered, and washed. The filtrate and washings are concentrated to about 50 c.c., cooled, and a sufficient

<sup>1</sup> A. O. A. C., *op. cit.*, 17.



amount of disodium hydrogen phosphate solution added to precipitate the magnesium, after which ammonium hydroxide is added slowly and with constant stirring until the solution is distinctly alkaline. It is ascertained if precipitation is complete by the addition of a little more of the precipitant. If no further precipitation results, the mixture is allowed to stand for 30 minutes, then 10 c.c. of strong ammonium hydroxide slowly added, the beaker covered, and placed in a cool place for 12 hours. The precipitate is then filtered through an ashless paper, washed with dilute (1:10) ammonium hydroxide till free of chlorides, and dried. The residue is separated from the filter paper, the latter placed in a weighed porcelain crucible and ignited. The precipitate is then added and the whole heated to a dull red heat for some time, finally raising the temperature. The magnesium residue is allowed to cool, and weighed as  $Mg_2P_2O_7$ . It is calculated to  $MgO$ .

$$\frac{\text{Weight } Mg_2P_2O_7 \times 0.362 \times 100}{0.5} = \text{per cent } MgO.$$

*Zinc Oxide.*<sup>1</sup>—A 25 c.c. portion of Solution A or 0.5 gram of ash is treated with 10 c.c. of 1 to 1 sulphuric acid in an evaporating dish and evaporated until dense fumes of sulphuric anhydride are evolved. After cooling, 40 c.c. of water are added, together with about a gram of 20 mesh aluminum, and the whole boiled for several minutes. The residue is then filtered off and washed with hot water. The filtrates and washings are made up to 200 c.c. and potassium hydroxide solution added until nearly neutral. A drop of methyl orange is introduced into the solution, and potassium carbonate added to within an acidity of a couple drops of 20 per cent sulphuric acid. Two c.c. of 5 per cent sulphuric acid is then added, the solution cooled, and a *rapid* stream of hydrogen sulphide passed through the solution for 40 minutes. After being allowed to settle, the precipitate is filtered off into an ashless paper and washed with cold water. The paper and its contents are then ignited in a weighed crucible and heated to 800 to 900°C., in a muffle furnace for an hour to convert the sulphide completely into oxide. It is weighed as  $ZnO$ .

<sup>1</sup> W. W. SCOTT, "Standard Methods of Chemical Analysis," 2nd ed. (1917), 484.

$$\frac{\text{Weight ZnO} \times 100}{0.5} = \text{per cent ZnO.}$$

*Barium Oxide.*<sup>1</sup>—A 25 c.c. portion of Solution A is diluted in a 400 c.c. beaker to 250 c.c. with water, and a slight excess of dilute hot sulphuric acid added slowly and with constant stirring. The beaker is then allowed to stand for some time on a water bath, and after the precipitate has settled, is decanted through an ashless filter paper or Gooch crucible. The precipitate is washed with dilute (0.5 per cent) sulphuric acid, transferred to the paper or crucible, and washed with hot water till free of acid. It is then dried and ignited for a half hour. The residue is weighed as BaSO<sub>4</sub> and calculated to BaO.

$$\frac{\text{Weight BaSO}_4 \times 0.657 \times 100}{0.5} = \text{per cent BaO.}$$

*Lead Oxide.*<sup>2</sup>—If barium is present a 25 c.c. aliquot of Solution A is treated with 50 c.c. of hot slightly ammoniacal ammonium acetate and 1 c.c. of a very dilute solution (1:10) of sulphuric acid added. The barium will precipitate out completely. This is filtered off, and a few drops more of the sulphuric acid added to the filtrate to insure the absence of barium. Five c.c. of concentrated sulphuric acid are then added and the mixture evaporated until dense fumes of sulphuric acid are given off. The dish is allowed to cool, and the contents then rinsed into a beaker containing 200 c.c. of water. The lead sulphate which separates out is filtered after an hour and washed with water containing 10 per cent sulphuric acid. It is then dried, ignited at a dull red heat, and weighed as PbSO<sub>4</sub>. This is calculated to PbO.

$$\frac{\text{Weight PbSO}_4 \times 0.736 \times 100}{0.5} = \text{per cent PbO.}$$

*Potassium and Sodium Oxides.*<sup>3</sup>—A 25 c.c. aliquot of Solution A is treated with ammonium hydroxide slowly until the precipitate formed just dissolves. It is heated to boiling and a slight excess of the alkali added to precipitate the iron, alumina, etc. The solution is boiled for a minute, poured onto a filter, and

<sup>1</sup> W. W. SCOTT, *lib. cit.*, 58.

<sup>2</sup> W. W. SCOTT, *lib. cit.*, 236.

<sup>3</sup> Association of Official Agricultural Chemists, *op. cit.*, 18.

washed with hot water. The precipitate is then returned to the original beaker, dissolved in a few drops of hydrochloric acid, and reprecipitated with ammonium hydroxide as above. It is washed until free of chlorides. The combined filtrates and washings are then evaporated to dryness, heated until the ammonium salts are expelled, and dissolved in hot water. Five cubic centimeters of barium hydroxide are then added, the solution heated to boiling, and the precipitate allowed to settle. If precipitation is complete, as ascertained by the addition of more of the barium hydroxide to the clear solution, the precipitate is filtered and washed with hot water. The filtrate is heated to boiling and ammonium hydroxide and ammonium carbonate added to precipitate out the calcium and barium. This residue is filtered, washed with hot water, and the filtrate and washings evaporated to dryness, and heated below redness to expel the ammonium salts. The residue is taken up in a little hot water, and a few drops of ammonium hydroxide, ammonium carbonate, and ammonium oxalate added. The mixture is warmed a few minutes on a water bath and allowed to stand several hours. It is then filtered, and the residue again evaporated to dryness on the water bath, and heated to dull redness until all ammonium salts are expelled, and the residue is white. The residue is taken up in a small amount of water, filtered into a weighed platinum dish, and a few drops of hydrochloric acid added. This is then evaporated to dryness on the water bath, heated to dull redness (not higher) and, after cooling in a desiccator, weighed as  $KCl + NaCl$ .

The chlorides may now be converted to sulphates by dissolving in a little water, and adding a few cubic centimeters of ammonium sulphate (75 grams to the liter), and digesting for several hours on a water bath. The solution is then filtered into a weighed platinum dish, evaporated to dryness, and ignited at a dull redness. A gram of powdered ammonium carbonate is added, and the ignition continued slowly until all ammonium salts are expelled. The residue is cooled and weighed as  $K_2SO_4 + Na_2SO_4$ .

From the weight of the chlorides and of the sulphates the amount of potassium and of sodium may be calculated.

Let the combined weight  $KCl + NaCl = a$ , and  $K_2SO_4 + Na_2SO_4 = b$ .

Let also the weight of  $K = x$ , and of  $Na = y$ .

$$\text{Then } x \frac{\text{KCl}}{\text{K}} + y \frac{\text{NaCl}}{\text{Na}} = a, \text{ or } 1.91x + 2.54y = a, \quad (1)$$

$$\text{and } x \frac{\text{K}_2\text{SO}_4}{2\text{K}} + y \frac{\text{Na}_2\text{SO}_4}{2\text{Na}} = b, \text{ or } 2.23x + 3.09y = b \quad (2)$$

By multiplying (1) by 1.168 and subtracting from (2) we get

$$0.13y = b - 1.168a,$$

from which

$$y = \frac{b - 1.168a}{0.13},$$

and by substitution in (2)

$$x = \frac{b - 3.09y}{2.23}.$$

K is then calculated to  $\text{K}_2\text{O}$ :

$$\frac{x \times 1.21 \times 100}{0.5} = \text{per cent } \text{K}_2\text{O},$$

and Na is calculated to  $\text{Na}_2\text{O}$ :

$$\frac{y \times 1.35 \times 100}{0.5} = \text{per cent } \text{Na}_2\text{O}.$$

If desired the  $\text{K}_2\text{O}$  may be determined in the residue of chlorides or sulphates as follows: The residue is dissolved in 100 c.c. of water and a platinum solution (containing the equivalent of 1 gram of metallic platinum, or 2.1 grams of  $\text{H}_2\text{PtCl}_6$  in each 10 c.c.) added in slight excess. The mixture is evaporated on a water bath to a thick paste, and the residue washed by means of a little 80 per cent alcohol into a weighed Gooch crucible, and washed again with the alcohol. The crucible is dried for 30 minutes at  $100^\circ$  to  $130^\circ\text{C}$ ., and weighed. The warming is repeated until the weight is constant. The potassium is in the form of  $\text{K}_2\text{PtCl}_6$ , and is calculated to  $\text{K}_2\text{O}$ .

$$\frac{\text{Weight } \text{K}_2\text{PtCl}_6 \times 0.194 \times 100}{0.5} = \text{per cent } \text{K}_2\text{O}.$$

To obtain the percentage of  $\text{Na}_2\text{O}$ , the potassium is calculated to KCl (weight  $\text{K}_2\text{PtCl}_6 \times 0.307 = \text{weight KCl}$ ), or to  $\text{K}_2\text{SO}_4$  (weight  $\text{K}_2\text{PtCl}_6 \times 0.359 = \text{weight } \text{K}_2\text{SO}_4$ ), depending on whether the combined sodium and potassium salts were weighed as chlorides or sulphates, and the value obtained subtracted from the weight of the two salts. The difference represents the weight of NaCl or  $\text{Na}_2\text{SO}_4$  present. This is calculated to  $\text{Na}_2\text{O}$ .

$$\frac{\text{Weight NaCl} \times 0.531 \times 100}{0.5} = \text{per cent } \text{Na}_2\text{O}.$$

$$\frac{\text{Weight } \text{Na}_2\text{SO}_4 \times 0.436 \times 100}{0.5} = \text{per cent } \text{Na}_2\text{O}.$$



*Sulphate.*<sup>1</sup>—A 25 c.c. portion of Solution A is diluted in a 300 c.c. beaker to 100 c.c. with water, heated to boiling, and drop by drop a 10 per cent solution of barium chloride added until no further precipitation occurs. The mixture is allowed to boil for 5 minutes and then set in a warm place for several hours. The precipitate is then decanted onto an ashless filter paper, washed with 20 c.c. of boiling water in the beaker, transferred to the filter, and the washing continued until free of chlorides. The precipitate is then dried, ignited, and weighed as BaSO<sub>4</sub>. It is calculated to SO<sub>3</sub>.

$$\frac{\text{Weight BaSO}_4 \times 0.343 \times 100}{0.5} = \text{per cent SO}_3.$$

*Chloride.*<sup>2</sup>—A half gram sample of the ash is dissolved in dilute (1:10) nitric acid, and any residue is filtered off and washed with water. An accurately measured volume of N/10 silver nitrate solution in slight excess of the amount required to precipitate the chloride is added to the combined filtrate and washings. The precipitate of silver chloride is allowed to stand at a warm temperature until settled, and is then filtered off and washed thoroughly with water. To the filtrate and washings 5 c.c. of a saturated solution of ferric alum to serve as an indicator, and a few c.c. of nitric acid, are added. The excess of silver is then titrated with N/10 potassium sulphocyanate solution until a permanent light brown color appears. The c.c. of the sulphocyanate solution used are equivalent to the c.c. of silver nitrate solution added in excess of that required for the precipitation of the chloride. This figure subtracted from the total c.c. of silver nitrate solution used gives, therefore, the c.c. of the latter required to precipitate the chloride. Since 1 c.c. of N/10 AgNO<sub>3</sub> is equivalent to 0.00355 gram Cl,

$$\frac{\text{C.c. AgNO}_3 \times 0.00355 \times 100}{0.5} = \text{per cent Cl.}$$

A method for determining the presence of traces of chloride in gelatin was suggested by Luppó-Cramer.<sup>3</sup> He places a small amount of a 10 per cent gelatin solution on a glass plate and sets it aside until it has solidified. A drop of a 10 per cent solution of silver nitrate is then added. In the

<sup>1</sup> A. O. A. C., *op. cit.*, 20.

<sup>2</sup> A. O. A. C., *op. cit.*, 19.

<sup>3</sup> LUPPÓ-CRAMER, *Z. Chem. Ind., Kolloide*, 5 (1909), 249.

presence of the slightest trace of chloride (0.001 per cent) an opalescent ring will be formed around the outside of the drop, and the breadth and turbidity of the area will increase after a few hours. An approximation of the quantity of chloride present may be made by comparing this test with other similar ones made by using known amounts of chloride.

Shuey<sup>1</sup> employed the precipitation method with silver nitrate obtaining excellent results. Ten grams of the glue are heated on a hot plate with about 2 grams of sodium carbonate in a porcelain dish until carbonized. The dish is then transferred to a muffle furnace at a very low red heat and allowed to remain until the carbon ceases to burn. The dish is then removed, cooled, and 25 c.c. of hot water added. Dilute nitric acid is then added until no further effervescence results, and the mixture decanted through a filter. The remaining charcoal is washed once with hot water, and returned in the original dish to the furnace where it is allowed to remain until the ash assumes a gray color. The dish is again cooled and the residue dissolved as before, filtered, and washed thoroughly on the filter. (A slight residue of carbon is often left on the filter, but the amount of chloride contained therein has been shown by several determinations to be only about 0.0003 per cent of the weight of the sample, and as the method is accurate to only 0.001 per cent, the loss is negligible.) The filtrate is heated to boiling, an excess of silver nitrate solution added, and the flask well shaken and heated to boiling until the precipitate settles clear. The precipitate is then collected on a weighed Gooch filter, dried at 200 to 400°C., and weighed. The silver chloride is calculated to chloride:

$$\frac{\text{Weight AgCl} \times 0.2475 \times 100}{10} = \text{per cent Cl.}$$

**4. The Organic Analysis of Gelatin.** *Protein, Proteose, Peptone, and Amino-acid.*—There are several ways by which gelatin and glue may be examined for their organic constituents. The material may be separated into protein, proteose, peptone and amino acids, and the distribution of the total nitrogen among these four groups determined. Such a separation is of considerable value in any study requiring information upon the degree to which the gelatin molecule has been hydrolyzed, and the exact form which such hydrolysis has taken. The procedure as finally adopted by the author after an extended study of the methods proposed is described on pages 25 to 28.

It should be emphasized, however, that this separation is entirely empirical. In a given material, as for example, a high grade glue, a slight precipitation begins at a comparatively low concentration of magnesium sulphate, *e.g.*, at 18 to 20 per cent of saturation, and with each increase in the concentration of the

<sup>1</sup> R. SHUEY, Unpublished Report to Mellon Institute (1912).

salt a greater amount of nitrogenous material is thrown down. The line of distinction between proteins and proteose has arbitrarily been placed at the 50 per cent of saturation point. That is, all nitrogenous material precipitated at concentrations of magnesium, zinc, or ammonium sulphate (to which a little sulphuric acid has been added) up to 50 per cent of saturation has been designated as protein, while all further precipitation up to complete saturation has been designated as proteose. While these distinctions are very useful when understood and intelligently applied, yet the arbitrariness of the differentiation should not be lost sight of. By an application of this procedure the author<sup>1</sup> has demonstrated the great dependence of viscosity, jelly consistency, and melting point upon the ratio of the protein nitrogen to the products of protein hydrolysis.

*“Hausmann” Numbers and Van Slyke Analysis.*—A somewhat more extended and in some respects a more comprehensive insight into the nature of the gelatin molecule may be obtained by a determination of the “Hausmann” numbers, or of the distribution of the nitrogen in groups by the Van Slyke method. These are described on pages 37 and 38 to 46 respectively. This method is obviously not suited to the study of hydrolysis, as before beginning the separations the sample must be completely hydrolyzed by an extended digestion with hydrochloric acid. But it does permit of a more searching inspection of the constitution of the gelatin molecule itself. The method has been applied not only to pure chemistry, the sole object of which was to learn of the molecular make-up of proteins, but to an estimation of the purity of proteins or to the relative percentages of two proteins present in a mixture.<sup>2</sup> The author<sup>3</sup> has applied the method to a study of glues with the intent of determining the relative amount of chondrin, mucin, keratin, etc., that were intermixed with the gelatin in the lower grades, and to distinguish between glues of marine and of animal origin.

*Fischer’s Esterification Method.*—The individual amino-acid constituents of a protein may be most conclusively recognized by isolating them by the esterification method of Fischer, and examining these several fractions by tests specific for the given amino-acids in question. By this procedure the presence or

<sup>1</sup> R. H. BOGUE, *Chem. Met. Eng.*, **23** (1920), 105. See pages 28 and 29.

<sup>2</sup> See M. J. BLISH, *J. Ind. Eng. Chem.*, **8** (1916), 138.

<sup>3</sup> R. H. BOGUE, *loc. cit.*, 155.

absence of any given amino-acid may usually be demonstrated, and approximations to quantitative data have been attempted. But with the exception of the analyses of Dakin the most painstaking work by the greatest chemists of the day has failed to account for more than a half to three quarters of the original material by this method. By no other method may the individual components of the molecule be so well demonstrated, but its defects are so great that its applications in research are strictly limited. A brief description of the process is given on page 35.

**5. Further Analytical Tests. Total Acidity or Alkalinity.**—For the estimation of the total acidity or alkalinity, the older method is as follows. A 5 gram sample is weighed into a 500 c.c. Erlenmeyer flask, allowed to soak in cold water until thoroughly swollen, brought into solution by warming, and recently-boiled distilled water added to bring the volume to about 300 c.c. Five drops of phenolphthalein indicator solution (0.1 per cent alcoholic solution) are added, and the color of the solution observed. If no change in color occurs on adding the indicator the solution was acid, while if a pink color develops, the solution was alkaline. If acid, the solution is then titrated with N/10 sodium hydroxide until the pink color just becomes permanent, and if alkaline, it is titrated with N/10 hydrochloric acid until the pink color just disappears. The results are usually expressed as the equivalent of a calculated amount of hydrochloric acid or of sodium hydroxide. That is:

$$\frac{\text{C.c. N/10 HCl used} \times 100}{5} = \text{alkalinity in terms of N/10 NaOH per } 100 \text{ grams.}$$

$$\frac{\text{C.c. N/10 NaOH used} \times 100}{5} = \text{acidity in terms of N/10 HCl per } 100 \text{ grams.}$$

*Hydrogen Ion Concentration.*—Whenever the equipment is at hand, much more comprehensive data may be obtained, however, by a direct determination of the hydrogen ion concentration of the glue or gelatin solution. For this purpose a 1 per cent solution is used, and the determination may be made by either the electrometric or the colorimetric methods. These procedures are described in detail in the Appendix, pages 579 to 606. The results are best expressed in terms of Sørensen's logarithmic



symbol pH (see Appendix, page 581), and indicate the exact concentration of hydrogen or hydroxyl ions in the solution.

*Free Mineral Acids.*—The free mineral acids may be determined by the *Hehner* method. A measured excess of standard alkali is added to a weighed portion of the sample in solution, the mixture placed in a porcelain crucible, evaporated to dryness, and ignited at a dull red heat. The ash is brought into solution with water, and titrated with standard acid, using methyl red as an indicator. The difference between the number of c.c. of alkali first added, and the number of c.c. of acid used in titrating the excess of alkali (the acid and base being of the same normality) represents the free mineral acid present. It is expressed as Free Mineral Acidity in terms of N/10 HCl per 100 grams.

*Free Organic Acids.*—The free organic acids are estimated by subtracting the free mineral acids from the total acidity. They are expressed in terms of N/10 HCl per 100 grams.

*Volatile Acids.*—The volatile acids may be determined by passing steam through a solution of the gelatin and collecting the distillate. Ten grams are dissolved in 500 c.c. of water that has recently been boiled to expel carbon dioxide. This is placed in a flask, connected to a condenser, and heat applied to incipient boiling. Steam obtained from water that has been boiled for several minutes before using in the determination is then passed through the solution and the distillate allowed to collect in a flask containing an excess of N/10 alkali and 3 drops of phenolphthalein indicator solution. About 150 c.c. are distilled over, and then the distillate titrated to neutrality with N/10 acid. The difference between the amounts of alkali and acid used indicates the amount of N/10 alkali required to neutralize the volatile acids from the 10 gram sample.

$$\frac{\text{C.c. alkali} - \text{c.c. acid} \times 100}{10} = \text{acidity due to volatile}$$

acids in terms of N/10 HCl per 100 grams. The volatile acids in glues and gelatins are usually confined to hydrochloric acid and sulphur dioxide.

*Fixed Acids.*—The fixed acids are estimated by subtracting the volatile acids from the total acids. They are expressed in terms of N/10 HCl per 100 grams.

*Amino-acids.*—The free amino-acids, together with the free carboxyl or amino groups of the protein, proteose, and peptone

molecules, may be accurately estimated by the Van Slyke method (described on pages 30 to 34) which determines the free amino groups, or by the Sørensen method (described on page 30) which determines the free carboxyl groups. The samples should be brought into solution in the usual way, and should not be more concentrated than 1 or 2 grams per 100 c.c.

Tague<sup>1</sup> has pointed out that amino-acids may be titrated by means of the hydrogen electrode<sup>2</sup> with distinct advantages, and with greater accuracy than by the use of the older methods. He finds that an hydroxyl ion concentration of about  $2 \times 10^{-2}$  (pH 12.5) is necessary to suppress completely the basic ionization of the sodium salts of the amino-acids, and thus make possible the titration. Sufficient standard alkali is added to a definite volume of the aqueous solution of the amino-acid to give it a pH of about 12.5. Standard alkali is also added to an equal volume of water so that it may have the same pH value and the same volume as the amino-acid solution. By subtracting the c.c. used in the blank from that required in the original, one obtains the c.c. of standard alkali necessary to neutralize the amino-acid alone.

The study of amino-acid titration has been carried further by Eckweiler, Noyes and Falk,<sup>3</sup> who present titration curves for a number of amino-acids, and discuss the relations found from the standpoint of the chemical structure of the substance.

*Sulphur Dioxide.*—The Association of Official Agricultural Chemists<sup>4</sup> employs the iodine titration method for the estimation of sulphur dioxide in foods. A 10 gram sample is dissolved in 500 c.c. of water and 5 c.c. of a 20 per cent solution of glacial phosphoric acid added. The mixture is placed in a flask and distilled in a current of carbon dioxide into a known excess of an N/20 solution of iodine. After 150 c.c. have distilled over, the distillate is titrated with an N/20 solution of sodium thiosulphate until the brown color of the iodine just disappears. The difference between the volume of iodine taken and the volume of sodium thiosulphate used represents the volume of N/20 iodine solution necessary to react with the sulphur dioxide distilled over. Iodine reacts with sulphur dioxide according to the equation:

<sup>1</sup> E. L. TAGUE, *J. Am. Chem. Soc.*, **42** (1920), 173.

<sup>2</sup> See Appendix page 587, for a discussion of electrometric titrations.

<sup>3</sup> H. ECKWEILER, H. NOYES, and K. FALK, *J. Gen. Physiol.*, **3** (1921), 291.

<sup>4</sup> Association Official Agricultural Chemists, *op. cit.*, 127.

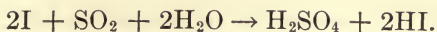

One c.c. of N/20 iodine solution is therefore equivalent to 0.0016 gram  $\text{SO}_2$ .

$$\frac{\text{C.c. iodine} - \text{c.c. sodium thiosulphate} \times 0.0016 \times 100}{10} = \text{per cent } \text{SO}_2.$$

Padé<sup>1</sup> employs the above procedure in a slightly modified form, but Gudeman<sup>2</sup> has pointed out that many animal and vegetable food products normally contain sulphur compounds which on distillation with acids give off volatile sulphur compounds which react with the iodine solution in the same manner as added sulphur dioxide, so that when the method is used to detect added sulphur dioxide positive results may be obtained when none was added, and high results when small amounts were added. Gudeman accordingly modifies the method by employing steam distillation, a rather heavy flow of low pressure steam being introduced to the distilling flask so that concentration cannot take place, and in large measure preventing the decomposition of the material which would result from such concentration. He finds the following amounts of sulphur dioxide in gelatins:

TABLE 49.—SULPHUR DIOXIDE GELATIN

	Official method		Modified method	
	Direct titration, per cent	After oxidation, per cent	Direct titration, per cent	After oxidation, per cent
Home made gelatin....	0.0002	0.0006	0.0000	0.0000
French gelatin.....	0.0270	0.0276	0.0260	0.0260
American gelatin.....	0.0130	0.0142	0.0120	0.0121

Horne and Winton<sup>3</sup> have suggested passing the distillate through solutions of metallic salts, such as cadmium, copper, silver, or lead salts, in which the hydrogen sulphide would be precipitated, before collecting in the iodine solution, or even adding the salts directly to the distilling flask. Any volatile

<sup>1</sup> PADÉ, *Ann. Chim. anal. chim. appl.*, **13** (1908), 299.

<sup>2</sup> E. GUDEMAN, *J. Ind. Eng. Chem.*, **1** (1909), 81.

<sup>3</sup> W. HORNE and A. WINTON, *Cf. E. GUDEMAN, loc. cit.*

sulphur compounds which did not appear as hydrogen sulphide would, however, pass over and react with the iodine, but a large portion of the error would be eliminated.

Leffman and La Wall<sup>1</sup> favor precipitating the sulphuric acid, produced by the oxidation of the sulphur dioxide by the iodine, with barium chloride, and weighing the precipitate as barium sulphate. They found many samples of gelatin containing as much as 300 or more parts per million of sulphur dioxide, but affirm that by proper methods of manufacture it is easily possible for this to be kept down to less than 10 parts per million.

Poetschke<sup>2</sup> also found the gravimetric method, by precipitating the sulphur as barium sulphate, more satisfactory than the iodine titration method. He found 20 per cent of all samples tested by him to contain less than 10 parts of sulphur dioxide per million; 48 per cent contained less than 100; 43 per cent contained from 100 to 500; and 3.3 per cent contained over 1000 parts per million.

The method of Poetschke has been found most satisfactory in the author's laboratory. The procedure is as follows: 27.5 grams of gelatin are weighed into a distilling flask, and 300 c.c. of water and a quantity of phosphoric acid weighing about 5 grams added. Carbon dioxide is passed through the flask until the air has been completely expelled, and the gelatin dissolved by placing in a bath of hot water. After solution of the gelatin, the flask is heated over a flame, a constant flow of CO<sub>2</sub> being maintained, until 175–200 c.c. of distillate have been obtained. This distillate is collected in a flask containing 25 c.c. of N/20 iodine solution, the flask being connected with the condenser, at the beginning of the operation, so that the end of the condenser reaches below the surface of the solution. Five c.c. of concentrated HCl are then added to the distillate, and the latter concentrated to about 75 c.c. It is then filtered, brought to boiling, and 10 c.c. of BaCl<sub>2</sub> solution added. The BaSO<sub>4</sub> is treated in the customary way and the amount determined gravimetrically. The weight of BaSO<sub>4</sub> gives directly the per cent of SO<sub>2</sub> if 27.5 grams of gelatin were used. A blank test should be made with the reagents.

*Formaldehyde.*—A sample weighing not less than 10 grams is dissolved in water and distilled by heating and passing steam through the solution. About 30 c.c. of the first distillate are

<sup>1</sup> LEFFMAN and LA WALL, *Analyst*, **36** (1911), 271.

<sup>2</sup> POETSCHKE, *J. Ind. Eng. Chem.*, **5** (1913), 980.



collected and divided into two portions. To one of these an equal volume of pure milk is added, followed by a little concentrated sulphuric acid. The presence of formaldehyde is noted by the development of a rose-purple color. One part of formaldehyde in 10,000 may be detected by this means. As a confirmatory test, the second portion is treated with a drop of dilute carbolic acid followed by concentrated sulphuric acid. A pink color indicates formaldehyde. This test also is very delicate.

*Fat or Grease.*—The material should be ground to a very fine powder, and 10 grams taken for the determination. If it is not possible to pulverize the material, the sample may be soaked in the minimum of water in an evaporating dish, warmed to bring into solution, and an absorbent material as infusorial earth added to absorb the moisture. The dried residue is ground finely in a mortar, care being taken that no loss occurs during these operations. The finely ground material, or the pulverized sample without such preliminary treatment, is then placed in a Soxhlet extraction thimble, a layer of fat-free cotton being placed above and below the sample. It is then extracted for 6 to 8 hours with petroleum ether which distills between 50 and 80°C. The receiving flask which should previously have been weighed is then removed, and the solvent evaporated off on a steam bath. The flask is then placed in an oven at 100°C. for an hour, cooled in a desiccator, and weighed. The increase in weight represents the amount of fat or grease in the 10 gram sample.

$$\frac{\text{Weight fat} \times 100}{10} = \text{per cent fat.}$$

If desired, the Roese-Gotlieb method may be substituted for the above to some advantage, the procedure being exactly as outlined for casein on pages 329–330.

An optional method has been suggested by Fahrion.<sup>1</sup> He digests a 10 gram sample on the water bath with 40 c.c. of alcoholic soda until the alcohol has volatilized. If solution is not then complete more alcoholic soda is added and the mixture again digested. The residue is taken up in hot water and if any insoluble inorganic matter is present this is dissolved by the addition of hydrochloric acid. The whole is then heated nearly to boiling for a half hour, rinsed into a separatory funnel, and when cold shaken with ether and left to stand over night. The two layers of solution are then run off separately and the insoluble oxy-fatty acids left in the funnel dissolved

<sup>1</sup> FAHRION, *Chem. Ztg.*, **23** (1899), 452.

in warm alcohol and mixed with the ethereal solution which contains the rest of the fatty matter. This is then evaporated on a water bath, dried and weighed. Some inorganic material may also have been dissolved in the ethereal solution, and to determine this the residue is ignited and again weighed. The weight of ash found is deducted from the fat as weighed, the difference being recorded as fat. There are two sources of error in the process: the glycerine of the glycerides is not determined, and the oxy-fatty acids are slightly soluble in the acid. The actual error introduced, however is small and usually insignificant.

*Insoluble Residue.*—A 5 gram sample is put into solution in 500 c.c. of water, and allowed to stand at room temperature for 2 hours. It is then decanted through a weighed Gooch crucible with a thin asbestos mat, the residue washed into the crucible with a little water and the precipitate washed twice with water. The crucible is then dried at 120°C., and weighed. The increase in weight is recorded as insoluble material.

$$\frac{\text{Weight insoluble material} \times 100}{5} = \text{per cent insoluble material.}$$

**6. Traces of Metals in Gelatin.**—In the manufacture of gelatin for food or medicinal purposes it is necessary that the product be practically free from metallic impurities that would impart poisonous properties, or that would render the material in the least questionable for human consumption. Unfortunately there are in the course of the manufacture several possible sources of such contamination. Arsenic may be introduced either through the use of impure acids used in the treatment of the bones, or as an impurity in the sulphur dioxide used in bleaching. If leather scraps are employed in the stock, arsenic may be further introduced through the arsenical preparations which may have been used in treating the hides for leather. In testing for arsenic in gelatin, Kopke<sup>1</sup> found 8 out of 12 samples of commercial gelatin to contain from 0.05 to 0.30 mg. of arsenic per 10 gram sample (0.0005 to 0.003 per cent). The remaining 4 samples also contained traces.

Copper may find access to the gelatin through the use of impure acids or bleaching agents, or by the use of copper kettles or containers. Hart<sup>2</sup> has examined a number of gelatins and gelatin containing preparations used for food purposes and found as

<sup>1</sup> KOPKE, *Arb. kais. Gesund.*, **38** (1911), 290.

<sup>2</sup> HART, *7th Internat. Congress Appl. Chem.*

much as 104 mg. of copper per 1,000 grams of gelatin (a little over 0.01 per cent).

Zinc, lead, and tin may also be present in small amounts, their origin being the use of impure chemicals in the manufacture, the addition of unlawful chemicals to produce certain desired properties, or the use of containers, boiling kettles or wire screens from which the metals in question may have been dissolved. Iron is always present in small amounts, but its presence is not injurious. Small amounts of alkali and alkaline earth metals are likewise present, but they are, of course, harmless in the form in which they are present in gelatin.

*Arsenic.*<sup>1</sup>—About 10 grams of the finely divided sample are weighed into a porcelain casserole, 10 to 15 c.c. of nitric acid are added, and after covering with an inverted watchglass, warmed until vigorous action is over. After cooling, 10 c.c. of concentrated sulphuric acid are added, and the mixture heated on a wire gauze over a flame until it turns brown or black, then more nitric acid added in 5 c.c. portions, heating after each addition, until the liquid remains colorless or yellow when evaporated until fumes of sulphur trioxide are evolved. All nitric and nitrous acid is removed by continuing the evaporation to about 5 c.c. It is then cooled, diluted with 10 to 15 c.c. of water, and again evaporated until white fumes are given off. It is again cooled, diluted with water, and made up with water to 25 or 50 c.c. in a volumetric flask, the volume being adjusted at room temperature.

The apparatus (see Fig. 98) and solutions for the determination should previously have been prepared. A 2 ounce glass bottle is used as a generator. A glass tube 1 cm. in diameter and 6 cm. long and containing a piece of lead acetate paper rolled into a cylinder, is fitted to the bottle by means of a perforated rubber stopper with a similar glass tube filled with absorbent cotton that has been soaked in 5 per cent lead acetate solution, and squeezed to remove excess of solution. The cotton in all sample



FIG. 98.—The apparatus for the determination of arsenic.

<sup>1</sup> A. O. A. C., *op. cit.*, 147.

tubes should be uniformly moist to obtain comparative stains. This tube is connected by a perforated rubber stopper with a narrow glass tube, 3 mm. in internal diameter and 12 mm. long, containing a strip of mercuric bromide paper. This paper is prepared by cutting heavy, close-textured drafting paper into strips exactly 2.5 mm. wide and about 12 cm. long. They are soaked for an hour in a 5 per cent solution of mercuric bromide in 95 per cent alcohol, the excess of solution then squeezed out, and dried on glass rods. The ends of the strips are cut off before using. All rubber stoppers used should be free from any white coating.

Twenty c.c. of the solution prepared as above directed from the gelatin is introduced into the 2 ounce bottle and 20 c.c. of dilute (1 : 2) arsenic-free sulphuric acid added, followed by 4 c.c. of a 20 per cent solution of potassium iodide. The generator is warmed to about 90°C., 3 drops of stannous chloride solution (40 grams of stannous chloride crystals made up to 100 c.c. with concentrated hydrochloric acid) added, and heated for 10 minutes. The generator is then cooled by placing in a pan containing water and ice, and when cold about 15 grams of arsenic-free zinc, broken into small sticks, are added, and the tubes as above described set in position into the generator. The bottle is allowed to remain in ice water for 15 minutes, is then removed and the evolution of gas permitted to proceed for an hour longer. The sensitized paper is then removed and compared with stains produced similarly with known amounts of arsenic, using portions of standard arsenic solution containing 0.001, 0.002, 0.005, 0.010, 0.015, 0.025, and 0.030 mg. of arsenious oxide ( $\text{As}_2\text{O}_3$ ), and quantities of water and sulphuric acid used in the test such that the same volume and acid strength are maintained as above.

The standard arsenic solution is prepared by dissolving 1 gram of arsenious oxide in 25 c.c. of 20 per cent sodium hydroxide solution, neutralizing with dilute sulphuric acid, adding 10 c.c. of concentrated arsenic-free sulphuric acid, and diluting to 1 liter with recently boiled water. One c.c. of this solution contains 1 mg. of arsenious oxide ( $\text{As}_2\text{O}_3$ ). Twenty c.c. of this solution are then diluted to 1 liter. Fifty c.c. of the latter solution when diluted to 1 liter give a dilute standard solution containing 0.001 mg. of arsenious oxide ( $\text{As}_2\text{O}_3$ ) per c.c. which is used to prepare the standard stains. The dilute solutions must be prepared immediately before use.



Blank tests must be conducted on all reagents, and results corrected accordingly.

The difficulty of digesting the sample with nitric and sulphuric acids until no brown coloration appears upon evaporating to fumes of sulphur trioxide will be obvious to anyone who has attempted it. Very satisfactory results have been obtained by merely hydrolyzing the gelatin with a dilute sulphuric acid for 2 hours, and proceeding as in the Official Methods, after making up to a standard volume.

*Copper.*<sup>1</sup>—Twenty grams of the powdered gelatin are weighed into an 800 c.c. Kjeldahl flask and 100 c.c. of concentrated nitric acid added. This is heated on a wire gauze over a free flame until the contents boil quietly. After cooling, 25 c.c. of concentrated sulphuric acid are added and the heating continued until white fumes are evolved. The flask is cooled, 5 c.c. of concentrated nitric acid added, and the heating continued. This procedure is repeated until the solution remains clear after boiling off the nitric acid and fumes of sulphur trioxide appear.

The solution is then concentrated by continued digestion until only 10 to 15 c.c. remain, then cooled and after diluting with water, transferred to a 400 c.c. beaker. The flask is rinsed out with water, and this added to the solution in the beaker. Water is added to a volume of about 200 c.c., and the solution boiled. After cooling, the solution is made slightly alkaline with ammonium hydroxide and boiled to expel the excess of ammonia, 5 c.c. of concentrated hydrochloric acid are then added for each 100 c.c. of solution, and the mixture heated to incipient boiling, and saturated with hydrogen sulphide. After standing on the steam bath for a few minutes until the precipitate flocculates, the latter is filtered off and washed with hydrogen sulphide water. The precipitate must be protected from the air as much as possible, and the operation carried on without interruption. The filtrate is reserved for the determination of zinc, if necessary. The filter containing the copper sulphide precipitate is placed in a small flask, 4.5 c.c. of concentrated sulphuric acid and the same volume of concentrated nitric acid are added, and heated until sulphur trioxide is evolved. The oxidation is continued with small additions of nitric acid until the liquid remains colorless upon heating to the appearance of the white fumes. The solution is then cooled, diluted with about 30 c.c. of

<sup>1</sup> A. O. A. C., *op. cit.*, 151.

water, and an excess of bromine water added. It is then boiled until the bromine is completely expelled, removed from the heat, and a slight excess of strong ammonium hydroxide added. The excess of ammonia is expelled by boiling, as shown by a change of color of the liquid, and a partial precipitation. A slight excess of strong acetic acid (3 to 4 c.c. of 80 per cent acid) is added and boiled for a minute. It is cooled to room temperature and 10 c.c. of 30 per cent potassium iodide added. The copper will oxidize this to iodine, and the latter is titrated at once with N/100 sodium thiosulphate until the brown tinge has become weak, then sufficient starch indicator (made by mixing 0.5 gram of finely powdered potato starch with cold water to a thin paste, then pouring into about 100 c.c. of boiling water, stirring constantly) added to give a blue coloration, and the titration continued until the color due to the iodine has entirely vanished.

The reactions involved are:

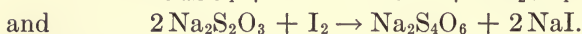
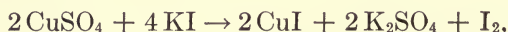

The thiosulphate solution must first have been standardized against pure metallic copper treated in the same manner as above. Two and five-tenth grams of  $\text{Na}_2\text{S}_2\text{O}_3 \cdot 5\text{H}_2\text{O}$  are dissolved in water and made up to 1 liter. In the standardization:

$$\frac{\text{Weight of copper taken}}{\text{C.c. thiosulphate required}} = \text{value of 1 c.c. thiosulphate solution,}$$

and in the determination:

$$\frac{\text{C.c. thiosulphate used} \times \text{value of 1 c.c.} \times 100}{\text{Weight of sample taken}} = \text{per cent Cu.}$$

A 5 hour digestion with dilute hydrochloric acid may be substituted to advantage for the nitric-sulphuric acid digestion described above.

*Zinc.*<sup>1</sup>—The filtrate from the copper sulphide precipitation, indicated above as to be reserved for the zinc determination, is boiled to expel hydrogen sulphide, and evaporated to a volume of 250 to 300 c.c. A drop of methyl orange and 5 grams of ammonium chloride are added and the solution made alkaline with ammonium hydroxide. Hydrochloric acid is then added, drop by drop, until faintly acid, and 10 to 15 c.c. of 50 per cent sodium or ammonium acetate solution added. Hydrogen

<sup>1</sup> A. O. A. C., *op. cit.*, 151.

sulphide is then passed into the solution for a few minutes until precipitation is complete. The precipitate is allowed to settle, filtered (repeating the filtration if necessary until the filtrate is clear), and washed twice with hydrogen sulphide water. The precipitate is dissolved on the filter with a little dilute (1 to 3) hydrochloric acid, the filter washed with water, and the filtrate and washings boiled to expel hydrogen sulphide. It is then cooled, an excess of bromine water added, 5 grams of ammonium chloride stirred in, and ammonium hydroxide introduced until the color caused by the bromine disappears. Dilute (1 to 3) hydrochloric acid is added, drop by drop, until the bromine color just reappears, then 10 to 15 c.c. of sodium or ammonium acetate solution (50 per cent by weight), and 0.5 c.c. of ferric chloride solution (10 grams per 100 c.c.) or enough to precipitate all of the phosphates. The solution is boiled until the iron is all precipitated, then filtered hot, and the precipitate washed with water containing a little sodium acetate. Hydrogen sulphide is passed into the combined filtrate and washings until all of the zinc sulphide, which should be pure white, is precipitated. This is filtered through a tared Gooch crucible and washed with hydrogen sulphide water containing a little ammonium nitrate. The crucible is dried in an oven, ignited at a bright red heat, cooled, and weighed as ZnO. This should be calculated to Zn.

$$\frac{\text{Weight ZnO} \times 0.8034 \times 100}{\text{Weight of sample}} = \text{per cent Zn.}$$

*Tin.*<sup>1</sup>—The material is brought into solution, and the organic matter destroyed exactly as described under "copper" in the first paragraph only. Two-hundred c.c. of water are added to the digested sample, and poured into a 600 c.c. beaker, rinsing out the Kjeldahl flask with three portions of boiling water, making the volume of solution about 400 c.c. It is cooled, and concentrated ammonium hydroxide added until just alkaline, followed by hydrochloric or sulphuric acid until the acidity is about 2 per cent. The beaker is covered, placed on a hot-plate, and warmed to about 95°C., when a slow stream of hydrogen sulphide is passed through the solution for an hour. The mixture is allowed to digest for another hour on the hot-plate and let stand 1 or 2 hours longer. The tin sulphide is then filtered through an 11 cm. filter (similar in quality to No. 590, white

<sup>1</sup> A. O. A. C., *op. cit.*, 149.

ribbon, S. & S.), and washed alternately with three portions each of wash solution and hot water. (The wash solution is made by combining 100 c.c. of saturated ammonium acetate solution, 50 c.c. of glacial acetic acid, and 850 c.c. of water.) The filter and precipitate are digested together in a 50 c.c. beaker with three successive portions of ammonium polysulphide, heating to boiling each time and filtering through a 9 cm. filter. The precipitate on the filter is washed with hot water. The filtrate and washings are acidified with acetic acid, digested on the hot-plate for an hour, allowed to stand over night, and filtered through a double 11 cm. filter. The precipitate is washed alternately with two portions each of the wash solution and hot water, and dried thoroughly in a weighed porcelain crucible. It is then ignited over a Bunsen flame, gently at first, but finally at full heat. The crucible, partly covered, is then heated strongly over a Meker burner. The stannic sulphide is thus converted to the oxide and is weighed as  $\text{SnO}_2$ . It is calculated to Sn.

$$\frac{\text{Weight SnO}_2 \times 0.7881 \times 100}{\text{Weight of sample}} = \text{per cent Sn.}$$

*Lead.*<sup>1</sup>—In small amounts, lead is best determined colorimetrically. If present between 10 and 50 parts per million a 1 gram sample is taken. If above or below these values, the amount of sample is regulated accordingly. The gelatin is brought into solution and digested with concentrated sulphuric acid and potassium hydrogen sulphate until colorless. It is then cooled and diluted with water. Ten c.c. of tartrate solution (25 grams of sodium potassium tartrate,  $\text{NaKC}_4\text{H}_4\text{O}_6 \cdot 4\text{H}_2\text{O}$ , is dissolved in 50 c.c. of water. A little ammonia is added followed by a solution of sodium sulphide. After settling it is filtered and the filtrate acidified with hydrochloric acid, boiled free of hydrogen sulphide, again made ammoniacal, and diluted to 100 c.c.), and 10 c.c. of hydrochloric acid are added, and the mixture brought to boiling. Any ferric iron present is reduced by adding 0.5 gram of sodium metabisulphite. Ammonium hydroxide is added to neutralize the free acid, and 5 c.c. in excess, then 3 c.c. of potassium cyanide solution (10 per cent, lead free) to repress any color due to copper, and the entire solution, or an aliquot portion, placed in a cylinder of a colorimeter and diluted to nearly 100 c.c. A standard lead solution made as described below is placed in the

<sup>1</sup> W. W. Scott, "Standard Methods of Chemical Analysis," 2nd ed. (1917), 243.



opposite cylinder and the readings taken. Any standard colorimeter may be used.

The standard lead solution may be prepared by dissolving 0.1831 gram of lead acetate,  $\text{Pb}(\text{C}_2\text{H}_3\text{O}_2)_2 \cdot 3\text{H}_2\text{O}$ , in 100 c.c. of water, clearing any cloudiness with a few drops of acetic acid, and diluting to 1 liter. Ten c.c. of this solution diluted to 1 liter will contain in each c.c. an equivalent of 0.000001 gram Pb. The standard solution is treated with sulphide solution at the same time as the gelatin solution, and treated similarly throughout.

## II. THE ESTIMATION OF GELATIN IN COMMERCIAL GELATIN AND GLUE

**1. Alcoholic Precipitation.**—A number of procedures have been proposed intending to differentiate between the "pure glue" and all other substances nitrogenous or otherwise that may be present, and designed as "non-glues." Stelling<sup>1</sup> states that as the value of a glue depends simply on its adhesive power, the only reasonable method of testing it is to attempt to determine the amount of substances other than gelatin that it contains. He points out that tannin precipitates the cleavage products of gelatin as well as the unhydrolyzed protein, and therefore discards the use of tannin. Physical tests he considers as variable with the process of manufacture. He accordingly treats the glue with alcohol. Fifteen grams are dissolved in 60 c.c. of water and 96 per cent alcohol added to make a volume of 250 c.c. After standing 6 hours 25 to 50 c.c. of the clear supernatant liquid are drawn off, evaporated to dryness, heated in an oven at 100°C., and weighed. The residue is termed non-glues, it being assumed that the true glue is completely precipitated under the above conditions, and to the exclusion of any non-glue material. He obtains percent ages of non-glues for the several types of glues as follows: Gelatin, 3.39; hide glues, 5.73; bone glues 10 to 16; pressed glues, 14 to 32; whole glue, 22; material used for clarification of wine, 33–59.

Müller<sup>2</sup> favors the tannin precipitation of gelatin for the higher grades and alcoholic precipitation for the lower grades of glues. He precipitates the gelatin with 96 per cent alcohol and determines the nitrogen in an aliquot of the filtrate. This value is deducted from the total nitrogen of the sample, the difference representing the nitrogen of the gelatin content.

<sup>1</sup> C. STELLING, *Chem. Ztg.*, **20** (1896), 461.

<sup>2</sup> A. MÜLLER, *Z. angew. Chem.*, **15** (1902), 482.

The author has found that alcoholic precipitation throws out the proteose as well as the protein, and as it is especially desirable that these components be separated, this method has not the advantages of the salt precipitation described later.

**2. Tannin Precipitation.**—Jean<sup>1</sup> suggested the use of tannin for precipitation of the gelatinous material, the purity of the glue being proportional to the amount of tannin required. One gram of the sample is dissolved in water and made up to 100 c.c. A 10 c.c. portion is mixed with 10 c.c. of a 1 per cent solution of pure tannin, and agitated with 5 grams of sodium chloride and 1 gram of sodium bicarbonate, to render the gelatin tannate insoluble. The mixture is poured onto a filter paper and the filtrate collected in a 100 c.c. graduated cylinder. A solution of sodium chloride (sp. gr. 1.184) is added to make a volume of 45 c.c., and a 0.4 per cent solution of iodine added drop by drop until the starch test reveals the presence of free iodine, whereupon the solution is made up to 60 c.c. with water, and more iodine solution added until a faint blue test is obtained with starch. The excess of tannin is thus estimated by the iodine titration (the equivalent of tannin solution per c.c. of iodine solution should previously have been determined) and by deduction from the original quantity of tannin added, the amount required to precipitate the gelatinous material is found.

Carles<sup>2</sup> takes exception to the above method by pointing out that the precipitating power of different commercial gelatins is very variable. For example 10 grams of Russian fish glue were found to throw down 4 grams of tannin, (at 40°C.), granulated gelatin 8 grams, cut fish glue 3 to 10 grams, and bone gelatin 11 grams.

A somewhat different procedure of evaluation was suggested by Gantter.<sup>3</sup> 100 grams of glue were heated in water with a few drops of sodium hydroxide until solution was effected, then made up to 2 liters. After standing 10 hours 20 c.c. of the liquid were evaporated to dryness, heated in an oven at 105°C., and weighed. This was then ashed and the weight of ash-free dry glue ascertained. Another 20 c.c. aliquot was treated with 30 c.c. of water, neutralized with acetic acid, and tannin solution added in excess. The mixture was shaken, made to 100 c.c.,

<sup>1</sup> F. JEAN, *Ann. Chim. Analyt.*, **2**, 85.

<sup>2</sup> P. CARLES, *Ann. Chim. Analyt.*, **2**, 181.

<sup>3</sup> F. GANTTER, *Z. anal. Chem.*, **32** (1893), 413

and filtered. The filtrate was then shaken with hide powder and allowed to stand 10 hours to ensure complete elimination of the tannin. It was then filtered, and 50 c.c. of the filtrate evaporated, dried, and weighed. This was deducted from the weight of the residue, and this weight of residue subtracted from the weight of ash-free dry glue previously obtained. The difference is taken as pure glue substance.

Many modifications of the tannin precipitation method of glue evaluation have been suggested. Müller<sup>1</sup> treated 10 c.c. of a 2 per cent glue solution with 25 to 30 c.c. of a 0.5 per cent tannin solution, and 20 c.c. of a 5 per cent potassium alum solution were added. This was warmed for a minute, filtered, and washed with water at 30°C. The filtrate was then titrated with standard potassium permanganate solution. To correct for reducing substances in the glue not precipitated by tannin a second determination was made in which the filtrate was treated with hide powder and titrated. The difference between the two titrations gives a measure of the gelatin present. One hundred grams of tannin were found to precipitate 139.1 grams of gelatin under the above conditions, and the results were unaffected by the presence of other nitrogenous impurities. In very impure glues, however, the alcoholic precipitation was preferred.<sup>2</sup>

By applying the method of Müller, Halla<sup>3</sup> determined the gelatin in a number of gelatinous substances. He found pure gelatin to contain 17.615 per cent of nitrogen, and so deduced the factor  $100.00/17.615 = 5.677$  for use in calculating gelatin from nitrogen. Halla reports the following data on his determinations:

TABLE 50.—ESTIMATION OF GELATIN IN GLUES

	Gelatin	M. P. of jelly	N in gelatin	Total N
Gelatin.....	82.73	36.5	14.57	14.83
Gelatin-glue.....	80.74	31.0	14.22	14.13
Glue powder.....	78.09	26.5	13.75	14.33
Size.....	74.44	25.0	13.11	13.80
Bone glue.....	74.11	25.0	13.05	14.59
Bone glue.....	69.72	24.5	12.28	14.21
Gilder's size.....	68.97	24.0	12.15	14.30

<sup>1</sup> A. MÜLLER, *Z. angew. Chem.*, **15** (1902), 482.

<sup>2</sup> A. MÜLLER, *idem*, 1237.

<sup>3</sup> HALLA, *ibid.*, **20** (1907), 24.

A study of the gelatin-tannin reaction was made by Trunkel<sup>1</sup> in 1910. He found that 1 gram of gelatin required 0.7 gram of tannin for complete precipitation when used in a freshly prepared condition, but after the gelatin solution had stood for 24 hours only 0.4 gram of tannin was required. If the latter solution is warmed, however, it regains its former power to precipitate tannin. Where the gelatin and the tannin are both quantitatively precipitated, the precipitate resists decomposition by water, but with an excess of tannin a precipitate may be obtained, containing 3 tannin to 1 gelatin which, however, yields up tannin on treatment with water. By repeated extraction of the precipitate with alcohol, up to 97 per cent of the tannin may be removed, but in no case can the precipitate be entirely resolved into its constituents. Only about 6 per cent of unaltered gelatinizable gelatin may be extracted from the residue. The action of alcohol leads Trunkel to believe that the precipitation of gelatin by tannin is an adsorption process.

**3. Picric Acid Precipitation.**—A study was made by Berrar<sup>2</sup> in 1912, upon the gelatin-picric acid reaction. He found that gelatin was precipitated quantitatively by the addition of an equal volume of picric acid at 8°C., or below. At higher temperatures even an excess of the picric acid failed to precipitate the gelatin completely. The nitrogen in the precipitate was estimated by a Kjeldahl determination after reduction with iron turnings and acetic acid. The gelatin-picric acid compound dissolved in a 2 per cent solution of urea containing sodium chloride, which makes the method useless for the estimation of gelatin in urine. The precipitate dissolved readily in alcohol, and this fact provides for the separation of gelatin from albumin, albumoses, peptones, mucin and casein, as the picric acid compounds of these substances are insoluble. For the estimation of gelatin in admixture with other proteins Berrar recommends that an aqueous mixture be treated with a solution containing 1 part of saturated picric acid solution in 4 parts of alcohol. The above mentioned proteins are precipitated and removed by filtration. The gelatin is then precipitated by cooling to 8° and adding an excess of picric acid. The picric acid method is also recommended as a test for gelatin in the presence of other proteins as

<sup>1</sup> TRUNKEL, *Biochem. Z.*, **26** (1910), 458.

<sup>2</sup> BERRAR, *Biochem. Z.*, **47** (1912), 189.



1 part of gelatin in 100,000 parts of solution yields a distinct turbidity on the addition of an excess of picric acid.

**4. Indirect Methods.**—A more ambitious attempt to obtain the evaluation of a glue by chemical examination was made by Fahrion.<sup>1</sup> He determined the water, ash, unsaponifiable matter, fatty acids, fluid oxy-acids, and solid oxy-acids, and estimated the "proteid" substance by difference. Two portions of 3 to 5 grams were weighed out, and one of these used for the moisture and ash determinations. The other was mixed with 15 to 25 c.c. of 8 per cent alcoholic soda, and evaporated to dryness on a water bath. The residue was taken up with alcohol and again evaporated to dryness. This was washed into a separatory funnel with hot water, hydrochloric acid added to acidify, and on cooling shaken with ether. The *solid oxy-acids* are left undissolved, and were estimated by dissolving in warm alcohol, evaporating by dryness, and weighing. The etherial extract was evaporated and the residue weighed. This was then treated with petroleum spirit, and shaken in a separatory funnel. The *fluid oxy-acids* are insoluble in this solvent, and were separated out and weighed. An alcoholic soda solution was then added and the alkaline layer containing the fatty acids separated from the petroleum spirit layer. The latter was evaporated to dryness and weighed, giving *unsaponifiable matter*. The alkaline solution was heated on a water bath to remove the alcohol, the residue diluted with water, decomposed in a separatory funnel with hydrochloric acid, and shaken out with petroleum spirit. The *fatty acids* were then obtained by evaporation and drying. The *proteid substance* was calculated by subtracting the sum of the other constituents from 100. The following table gives some of the results obtained:

TABLE 51.—GLUE EVALUATION BY FAHRION'S METHOD

	Water	Ash	Unsaponifiable matter	Fatty acids	Fluid oxy-acids	Solid oxy-acids	Proteid substance
Glue.....	13.74	1.80	0.49	0.08	0.04	0.27	83.58
Hide powder.....	19.15	0.25	0.72	0.18	0.08	0.37	79.25
Purified leather.....	11.23	10.06	9.74	0.99	0.46	1.01	66.51
Horn.....	9.09	1.00	0.68	1.03	0.29	1.49	87.62
Bone.....	10.00	53.87	4.81	4.23	0.19	1.52	25.38

<sup>1</sup> FAHRION, *Z. angew. Chem.*, 8 (1895)529.

Mavrojannis<sup>1</sup> has proposed the use of formaldehyde for the separation of protein and proteose from the more completely hydrolyzed peptones and amino-acids. The former two fractions are rendered insoluble by the formaldehyde, while the latter are unaffected.

Greifenhagen, König, and Scholl<sup>2</sup> have examined the various methods proposed and find none of them entirely satisfactory. The formaldehyde method they find to be useless. Precipitation with Nessler's reagent in the presence of a tartrate was found to yield quantitative results, but the proteoses were also precipitated. Trichloroacetic acid in large excess yielded a turbidity with very dilute solutions of gelatin, and did not precipitate the proteoses completely. Mercuric chloride was found to precipitate proteose from neutral solutions, but not gelatin. The proteoses were not, however, precipitated completely. If the gelatin and proteoses were precipitated together with zinc sulphate and the nitrogen determined, and in another aliquot the zinc sulphate precipitate dissolved and the proteoses thrown down with mercuric chloride, the nitrogen content was found to be about the same if no gelatin was present, but greater in the former precipitation if gelatin was present. Mercuric iodide in alcohol or acetone was also found to be a precipitant for gelatin.

In the author's experience mercuric chloride cannot be used to separate gelatin from proteose, as the former is also thrown down to a considerable extent by that reagent.

**5. Salt Precipitation.**—Trotman and Hackford<sup>3</sup> in 1904 called attention to the existing disparity in the methods proposed or in use for the determination of the purity of gelatins and glues, and proposed a method based upon the precipitation of the "albumoses," which in fact included the proteins and proteoses, by saturating their solution with zinc sulphate. They first determined the total nitrogen by Kjeldahl's method, then the "albumoses" by precipitating with zinc sulphate and subjecting the precipitate to a Kjeldahl determination. The nitrogen obtained by both of these determinations was multiplied by the factor 5.33. The difference between the total nitrogen  $\times$  5.33 and the proteoses was taken as peptones.

<sup>1</sup> MAVROJANNIS, *Z. Hygiene*, **45** (1904), 108.

<sup>2</sup> GREIFENHAGEN, KÖNIG, and SCHOLL, *Biochem. Z.*, **35** (1911), 217.

<sup>3</sup> S. TROTMAN and J. HACKFORD, *J. Soc. Chem. Ind.*, **23** (1904), 1072.

The procedure was as follows: 1 gram of finely powdered glue was dissolved in 20 c.c. of water. While still hot, zinc sulphate crystals were added in excess to saturate the solution. The coagulated "albumoses" were then either filtered off, or caused to cling to the rod and beaker, and the clear liquid and crystals decanted off. The precipitate was washed with saturated zinc sulphate solution, dissolved in concentrated sulphuric acid, and subjected to the Kjeldahl determination, the nitrogen found being multiplied by 5.33.

The results obtained are reported in the following table:

TABLE 52.—ZINC SULPHATE PRECIPITATION OF "ALBUMOSES"

	Jelly consistency	Total N × 5.33 "gelatin"	N precipitated by Zn- SO <sub>4</sub> × 5.33 "Albu- moses"	Peptones by difference
Best gelatin.....	150	74.03	72.22	1.81
Same boiled 2 hours.....	143	74.03	71.36	2.67
Glue.....	135	71.64	69.54	2.10
Glue.....	120	74.62	68.05	6.57
Glue.....	110	74.30	67.0	7.3
Glue.....	90	71.04	64.18	7.86
Overboiled glue.....	40	73.02	57.99	15.03

These data show an unmistakable relationship between the jelly consistency and the "albumoses." The results would be of somewhat greater value, however, if the precipitations had been conducted at a fixed and not too high temperature, and allowed to come to complete equilibrium at that temperature by standing for a number of hours.

The author<sup>1</sup> has shown that considerable differences in the degree of precipitation are experienced, in the case of magnesium sulphate, by a few degrees variation in temperature, and an enormous difference by very slight variations in the acidity of the solution. From 3 to 8 per cent more nitrogen was thrown down at 17° than at 25° as shown by the following table:

<sup>1</sup> R. H. BOGUE, *Chem. Met. Eng.*, **23** (1920), 105.

TABLE 53.—EFFECT OF TEMPERATURE ON MAGNESIUM SULPHATE PRECIPITATIONS

Precipitated and filtered at 25°C., per cent of total N	Precipitated and filtered at 17°C., per cent of total N	Precipitated at 17°C., filtered at 30°C., per cent of total N
41.9	50.1	41.3
44.8	52.0	46.0
50.9	57.7	49.7
....	58.3	50.3
55.5	58.7	51.7
56.2	59.4	52.2
53.7	56.2	50.9

The effects of acidity on the precipitation was much greater. With no acid added only 2.95 per cent of the total nitrogen was thrown down, while by the addition of 0.5 c.c. of dilute (1:4) sulphuric acid 41.3 per cent of the total nitrogen was precipitated. Further additions of acid resulted in decreased precipitations. These results are shown in graph form in Fig. 4 (page 26).

By an application of the magnesium sulphate precipitation method, the author<sup>1</sup> has thrown out the protein by half saturation and the proteose and protein together by full saturation of the salt. Peptone and amino-acid were also determined. Results of the greatest significance and value may be obtained by this procedure.

### III. THE DETECTION AND ESTIMATION OF GELATIN AND GLUE IN FOODS AND MISCELLANEOUS PRODUCTS

**1. Gelatin in Meat and Meat Products.**—The presence of gelatin in meat extracts is due not to the occurrence of that protein in the juices of the meat, for these have been shown to be practically free of gelatin, but rather to the hydrolytic action of the hot water or steam upon collagenous tissues that are present in the meat fiber, as connective tissue, tendons, cartilage, etc. In small amounts gelatin is not regarded as an impurity in meat extracts, but if present in large amounts the indication is that either inferior material was used in the preparation, or that

<sup>1</sup>Vide pages 25 to 29.



gelatin has been added deliberately as an adulterant. The percentage of gelatin in various meat extracts is shown in the following table by Hehner, cited after Richardson.<sup>1</sup>

TABLE 54.—GELATIN CONTENT OF MEAT EXTRACTS

Description	Gelatin	Description	Gelatin
Liebig's <i>Extractum Carnis</i> ..	5.18	Vitalia Meat Juice.....	0.45
Armour's Extract of Meat..	3.31	Brand's Essence of Beef..	5.12
Brand's <i>Extractum Carnis</i> ..	4.56	Borvil's Fluid Beef.....	3.81
Liebig's Extract (Borvil & Co.) .....	5.50	Borvil's Fluid Beef, unseasoned.....	1.06
Brand's Meat Juice.....	0.69	Borvil for Invalids.....	4.56
Valentine's Meat Juice.....	0.75	Borvil for Invalids.....	2.56
Wyeth's Meat Juice.....	1.12	Caffyn's <i>Liquor Carnis</i> ....	0.25
Borthwick's Bouillon.....	1.37	Extract of Meat with Vegetable Extract.....	1.69

*Alcoholic Extraction.*—An ingenious method for separating the gelatin from a meat extract was suggested by Stutzer<sup>2</sup> in 1895. The procedure depends upon the insolubility of gelatin in alcohol and cold water, it being assumed that all other ingredients of the extract are soluble. Five to seven grams of the dry, or 20 to 25 grams of the fluid extract are weighed into a tinfoil dish and sufficient hot water added to dissolve the extract. Ignited sand, free of dust, is then added in sufficient quantity to absorb the whole of the liquid, and placed in an oven at 100°C., till the weight is constant. The sand and extract are then ground in a mortar, the tinfoil cut into strips, and the whole placed in a beaker and extracted four times with absolute alcohol, the supernatant liquid being decanted through an asbestos filter. The residue is then treated as follows: The beaker containing the residue is placed in ice water and 100 c.c. of a mixture of alcohol and ice water (100 grams of alcohol + 300 grams of ice + 600 grams of water) added. After stirring for 2 minutes the supernatant liquid is poured into a beaker. This is repeated four times, saving the wash water each time in a different beaker. The residue is filtered through an asbestos filter, and the several

<sup>1</sup> W. D. RICHARDSON, "Allen's Commercial Organic Analysis" (1913), vol. 8, p. 398.

<sup>2</sup> STUTZER, *Z. anal. Chem.*, **34** (1895), 568.

wash waters filtered through separate filters. After washing with the alcohol-ice-water, all the filters, the sand, and the first filter from the absolute alcohol treatment are boiled with water in a porcelain dish, filtered, and the filtrate concentrated by evaporation. The concentrated residue is then subjected to a Kjeldahl nitrogen determination. The nitrogen value 5.55 was used in calculating gelatin. From 95 to 98 per cent of the total gelatin is obtained in this way, but any proteoses that are present are also insoluble in the alcohol ice-water and are thus determined with the gelatin.

Practically the same procedure was used by Kutscher<sup>1</sup> in 1905.

*Chlorine Precipitation.*—Rideal and Stewart<sup>2</sup> in 1897 suggested the separation of gelatin from the other constituents of meat extract by precipitation with chlorine. One hundred c.c. of the liquid containing not more than 0.2 per cent of "proteids" are used. Chlorine gas is allowed to bubble through the solution for some time. The solution remains clear for a while and then begins to froth strongly, the bubbles being enclosed in a white film. The frothing ceases shortly, and a precipitate forms which easily settles leaving a clear supernatant liquid. As soon as this liquid shows a yellow color the supply of chlorine is shut off. After standing for some hours the precipitate which is granular is filtered on a hardened filter paper with suction, and washed with cold water till free of chlorine. It is then dried first in warm air, and later *in vacuo* over sulphuric acid. If heated above 70 to 80°C. decomposition ensues. The dried precipitate, which is a pale, yellowish white, inodorous powder, is weighed, and gelatin calculated.

The results obtained by the originators were found to compare favorably with the tannin precipitation, while the process was much easier of manipulation. The precipitate was very stable at ordinary temperatures, but when heated readily decomposed, becoming nearly black, and rotting the filter paper. In the precipitation, hypochlorous acid seemed to be the principal product.

*Bromine Precipitation.*—Allen and Searle<sup>3</sup> investigated the action of bromine on gelatin and found that it could be substituted for chlorine in the above process to advantage. The results

<sup>1</sup> KUTSCHER, *Z. Nahr. Genussm.*, **10** (1905), 528; **11** (1906), 582.

<sup>2</sup> S. RIDEAL and C. STEWART, *Analyst*, **22** (1897), 228.

<sup>3</sup> A. ALLEN and A. SEARLE, *Analyst*, **22** (1897), 259.

obtained and the reactions involved were practically identical with those produced by chlorine but the procedure was easier of manipulation. In either case the proteoses, peptones, albumin, and syntonin were thrown down with the gelatin, but creatine, creatinine, asparagine and aspartic acid were not precipitated in an acidified solution.

One hundred c.c. of the solution containing about 1 gram of gelatinous or albuminous matter are treated with dilute hydrochloric acid until distinctly acid to litmus. Bromine water is then added in large excess, and stirred vigorously for some time. The precipitate is at first flocculent, but soon becomes viscous and adheres to the rod and beaker. It is allowed to stand for a half hour, then filtered through an asbestos filter and washed with cold water. The filter and rod are then returned to the original beaker, 20 c.c. of concentrated sulphuric acid added, and the covered beaker warmed over a wire gauze. When the frothing has ceased 10 grams of potassium sulphate are added, and the heating continued until colorless. The determination is finished by the usual Kjeldahl distillation.

The nitrogen  $\times 5.5$  gives the gelatin precipitated by the bromine. The bromine precipitate is insoluble in water and dilute hydrochloric acid, and is less easily handled than the chlorine compound as it is not granular like the latter.

Some results obtained by Allen and Searle by the bromine method are tabulated below:

TABLE 55.—BROMINE PRECIPITATION OF GELATIN

	N per cent		N $\times$ factor		Factor employed
	Total in original substance	Precipitated by bromine	Total in original substance	Precipitated by bromine	
Commercial gelatin.....	14.10	14.00	76.42	76.14	....
Gelatin peptone.....	14.10	13.90	76.42	75.44	5.5
Commercial scale albumin....	8.80	8.72	55.8	55.2	....
Syntonin from scale albumin..	9.86	9.76	62.41	61.78	....
Digested scale albumin.....	8.89	8.81	56.3	55.8	....
Fresh white of egg.....	1.89	1.88	11.96	11.90	....
Syntonin from white of egg....	1.89	1.89	11.96	11.96	6.33
Peptone from white of egg....	0.70	0.69	4.43	4.37	....
Beef extractives.....	0.33	0.004	2.11	0.03	....

*Formaldehyde Precipitation.*—Beckmann<sup>1</sup> has proposed the use of formaldehyde for the estimation of gelatin in meat extracts.

<sup>1</sup> E. BECKMANN, *Rept. 13th Assembly Bavarian Chemists* (1894), 18.



The method is based upon the fact that gelatin combines with formaldehyde to form a non-fusible and insoluble compound, formo-gelatin. The coagulable albumins are also precipitated, but these may easily be determined in an aliquot of a water solution by throwing out with acid. Another aliquot is then treated with formalin, steamed on a water bath, and after boiling for a short time with water the residue is collected in a Gooch filter, dried at 100°C., and weighed. By deducting the amount of albumins previously found, the gelatin is obtained. Peptones were found not to be affected by the formaldehyde treatment.

*Tannin Precipitation.*—The Association of Official Agricultural Chemists<sup>1</sup> has adopted the tannic acid precipitation method for the estimation of gelatin, proteoses, and peptones in meats. A 7 to 25 gram sample of the finely macerated meat is weighed into a 150 c.c. beaker, 5 to 10 c.c. of cold (15°C.) ammonia-free water added, and stirred to a paste. Fifty c.c. of cold water are then added and stirred every 3 minutes for 15 minutes, then decanted onto a filter, and drained by pressing with a glass rod. Fifty c.c. more of water are added to the meat in the beaker, this stirred for 5 minutes and decanted as before. The extraction as above is repeated using the following additional amounts of cold water: 50, 50, 25, 25, 25, and 25 c.c. After the last extraction the meat is transferred to the filter and washed three times with 10 c.c. portions of water. The extract is collected in a 500 c.c. volumetric flask, and made up to the mark with water. One hundred and fifty c.c. are placed in a 250 c.c. beaker and evaporated to 40 c.c. on a steam bath with occasional stirring. It is then neutralized to phenolphthalein, 1 c.c. of normal acetic acid added, and boiled gently for 5 minutes. The coagulum is filtered off, and washed four times in the beaker and three times on the filter with hot water. The filtrate and washings are made up to 200 c.c. and designated as Solution A. An aliquot of 50 c.c. is transferred to a 100 c.c. graduated flask, and 15 grams of sodium chloride and 10 c.c. of cold water added. The flask is shaken until the sodium chloride has dissolved, then cooled to 12°C., and 30 c.c. of a 24 per cent tannin solution added. The flask is filled to the mark with water at 12°, the mixture shaken well, and allowed to stand at that temperature for 12 hours or more. The precipitate is

<sup>1</sup> A. O. A. C., "Methods of Analysis" (1920), 215.



then filtered off, and 50 c.c. of the filtrate treated with a few drops of sulphuric acid and evaporated *in vacuo* to dryness. The residue is subjected to a Kjeldahl nitrogen determination (page 431). A 50 c.c. aliquot of Solution A is also subjected to a Kjeldahl nitrogen determination, and, from the value obtained is deducted twice the value of the first mentioned nitrogen determination. The difference obtained is multiplied by 6.25 to give the gelatin, proteose and peptone. This figure divided by the weight of meat represented by the aliquot taken, and multiplied by 100 gives the percentage of these constituents in the meat.

The peptones and most of the proteoses will undoubtedly be determined by the above (tentative) method, but one is at difficulty to understand how unhydrolyzed gelatin may be extracted with water at 15°C.

*Salt Precipitation.*—The method for the determination of gelatin and proteoses in meat extracts adopted by the Association of Official Agricultural Chemists,<sup>1</sup> is the zinc sulphate precipitation method. A sample of 5 grams of powdered preparations, 8 to 10 grams of pasty extracts, or 20 to 25 grams of fluid extracts is dissolved in cold water, and filtered. Coagulable proteins are removed by neutralizing to phenolphthalein, adding 1 c.c. of normal acetic acid, boiling 3 minutes, cooling, diluting to 500 c.c., and filtering through a folded filter. The filtrate is evaporated to a small volume and saturated with zinc sulphate (85 grams to 50 c.c. solution). After standing several hours the residue is filtered and washed with a saturated solution of zinc sulphate. The filter paper with its contents is then placed in an 800 c.c. Kjeldahl flask, and the nitrogen determined. The figure obtained multiplied by 6.25, divided by the weight of sample taken, and multiplied by 100, is taken as the percentage of gelatin and proteose in the meat extract.

The above procedure somewhat modified was employed by Emery and Henley<sup>2</sup> in an exhaustive study of meat extracts in 1919. Twenty-five c.c. of a 10 per cent solution of the solid extract or a 20 per cent solution of the liquid extract were placed in a 50 c.c. graduated flask, 1 c.c. of a 50 per cent sulphuric acid solution added, with zinc sulphate sufficient to saturate the solution, and then a saturated solution of the same

<sup>1</sup> A. O. A. C., *op cit.*, 222.

<sup>2</sup> J. EMERY and R. HENLEY, *J. Agr. Res.*, 17 (1919), 1.

salt added to make 50 c.c. After standing 18 hours it was filtered and 20 c.c. of the filtrate employed for a nitrogen determination by the Gunning process. The total nitrogen of the extract, less the sum of the coagulable and insoluble nitrogen, which had previously been determined, and the zinc sulphate filtrate nitrogen, represented the nitrogen of the zinc sulphate precipitate. This value includes both the gelatin and proteoses.

In order to obtain comparative data, a tannic acid precipitation was also employed. For this 20 c.c. of the solution as above were placed in a 100 c.c. graduated flask, 50 c.c. of a saturated solution of sodium chloride added, and the flask filled to the mark with a 24 per cent solution of tannic acid. After mixing thoroughly it was placed in the ice box and allowed to stand over night, any loss in volume being made good with the tannic acid solution. The mixture was filtered in the ice box on the following day, and 50 c.c. of the filtrate transferred to a Kjeldahl flask, evaporated to dryness on a water bath, and the nitrogen in the residue determined by the Gunning method. The nitrogen of the tannic acid precipitate was then calculated by deducting the sum of the tannic acid filtrate, the coagulable, and the insoluble nitrogen from the total nitrogen.

The following table gives some of the data obtained. It will be observed that the nitrogen by the tannic acid precipitation is

TABLE 56.—DISTRIBUTION OF NITROGEN IN MEAT EXTRACTS

Source of extract	Commercial extracts			Laboratory extracts		
	Total N <i>per cent</i>	Per cent of total N		Total N <i>per cent</i>	Per cent of total N	
		ZnSO <sub>4</sub> precipitate	Tannic acid precipitate		ZnSO <sub>4</sub> precipitate	Tannic acid precipitate
Chuck and plate.....	10.08	17.75	44.13	11.67	21.57	48.87
Beef hearts.....	9.02	17.17	39.99	8.77	11.17	30.76
Hog spleens.....	9.38	26.53	52.45	9.98	23.74	56.10
Hog liver.....	6.00	18.66	53.33	8.14	24.19	58.37
Hog liver.....	6.00	18.70	53.25	6.52	9.35	52.30
Roast beef soak water...	8.99	10.34	44.05	.....	.....	.....
Corn beef cook liquor....	9.23	17.21	41.04	.....	.....	.....
Beef bones.....	9.47	13.58	47.96	8.26	15.25	20.1
Beef spleens.....	9.98	30.07	51.81	9.98	23.7	56.0
Beef liver.....	6.42	23.23	57.29	.....	.....	.....

much greater than that by the zinc sulphate method. This is due to the fact that the former method precipitates peptones in addition to the gelatin and proteoses thrown down by the zinc sulphate. This shows, incidentally, that the two methods may not be used indiscriminately.

**2. Gelatin in Milk, Cream and Ice Cream.** *Picric Acid Precipitation.*—The picric acid test for gelatin in milk and cream was suggested by Stokes<sup>1</sup> in 1897, and has been adopted by the Association of Official Agricultural Chemists.<sup>2</sup>

To a 10 c.c. sample is added an equal volume of acid mercuric nitrate solution (mercury dissolved in twice its weight of concentrated nitric acid, and this solution diluted to 25 times its volume with water). The mixture is shaken, 20 c.c. of water added, and again shaken. After standing for 5 minutes it is filtered. If much gelatin is present the filtrate will be opalescent and cannot be obtained altogether clear. A portion of the filtrate is added in a test tube to an equal volume of saturated aqueous picric acid solution. If gelatin is present in any considerable amount a yellow precipitate will be produced, while smaller amounts will produce a cloudiness. If no gelatin is present the solution will remain clear. Stokes affirms that this test will show the presence of 1 part of gelatin in 10,000 parts of solution.

Patrick<sup>3</sup> has pointed out that if a milk or cream showing no test for gelatin by the picric acid test when sweet, is allowed to sour, a very perceptible turbidity is often obtained upon the addition of the picric acid that would lead to the assumption that gelatin was present. He believes this is due to the formation by bacteria of a "pseudo-gelatin" decomposition product that is not distinguishable by any test from true gelatin.

Seidenberg<sup>4</sup> has shown, however, that the turbidity or precipitation in the above cases may be distinguished by differences in their solubility in hot neutral water. While both are soluble on heating in slightly acid solutions, only the gelatin picrate is soluble in hot neutral water alone. The picric acid precipitate from the sour cream is apparently quite insoluble in hot water after the complete removal of all of the picric or other acid. The precipitate obtained by the regular procedure is filtered, after

<sup>1</sup> A. W. STOKES, *Analyst*, **22** (1897), 320.

<sup>2</sup> A. O. A. C., *op. cit.*, 229.

<sup>3</sup> G. E. PATRICK, U. S. Dept. Agr. *Bull.* 116 (1908), 24.

<sup>4</sup> A. SEIDENBERG, *J. Ind. Eng. Chem.*, **5** (1913), 927.



shaking to produce coalescence, and washed with water, containing 2 drops of ammonium hydroxide per 100 c.c. of solution, until the washings are slightly alkaline to litmus, and then with neutral water until the washings are neutral to litmus. The precipitate, or the entire filter paper, are then transferred to a small beaker and 10 to 20 c.c. of water added and heated to boiling. This is then filtered. The filtrate will contain the gelatin picrate but not the precipitate derived from the decomposition products in the sour cream. The filtrate is cooled and an equal volume of picric acid added. If gelatin is present in the original cream a decided precipitate will be formed.

*Qualitative Identification of Thickeners and Gelatinizing Agents.*

A variety of substances are in use as thickeners and gelatinizing agents in ice cream, jellies, jams, and other food materials. These sometimes are of advantage, and perhaps not less frequently are added with the intent of concealing the inferiority of the product. The detection of these substances is often difficult and uncertain. Congdon<sup>1</sup> has suggested a scheme by which all of the common materials employed for this purpose may be detected either when present alone, or when several or all are present together. The materials included in the scheme are starch, dextrin, gelatin, acacia, agar-agar, tragacanth, albumin, and pectin bodies of the fruit juices. In order that the treatment used may be comprehensively presented, the complete procedure of Congdon is shown in the table on the following page.

**3. Gelatin in Other Food Products.** *Gelatin in Fruits and Fruit Products.*—Henzold<sup>2</sup> has proposed a method for the estimation of gelatin in fruit juices by precipitating with potassium dichromate. He dilutes the sample with water, boils, and filters off any insoluble material. To the solution is then added an excess of 10 per cent potassium dichromate solution, the mixture again brought to a boil, and cooled at once by placing the flask in cold water. When cold, 2 to 3 drops of concentrated sulphuric acid are added. If gelatin is present a precipitate appears which is at first white and flocculent, but soon coheres into lumps and sticky masses which separate out. This precipitate may be filtered off, if quantitative results are desired, and subjected to a nitrogen determination by the Kjeldahl process.

<sup>1</sup> L. A. CONGDON, *J. Ind. Eng. Chem.*, **7** (1915), 606.

<sup>2</sup> HENZOLD, *Z. öffent. Chem.*, **6** (1900), 292.



## IDENTIFICATION OF GELATINIZING AGENTS

Group reagent	Reactions with water-soluble solutions
Group I Iodine Solution.	Blue coloration indicates <i>starch</i> . Purple coloration indicates <i>amylodextrin</i> . Red coloration indicates <i>erythro-dextrin</i> . No coloration may indicate neither starch nor dextrin, but may be <i>achro-dextrin</i> .
Group II Millon's or Stoke's reagent (acid nitrate of mercury).	Mixture, after shaking substance in solution with reagent, is cloudy. Yellow precipitate with picric acid solution indicates gelatin. Drop of this reagent: Gelatinous precipitate, soluble in excess of this reagent, indicates <i>acacia</i> . A slight white cloudy precipitate may indicate either <i>agar-agar</i> or <i>tragacanth</i> , or both.
Group III Concentrated solution of sodium borate.	A white gelatinous precipitate indicates either <i>agar-agar</i> or <i>acacia</i> or both. <i>Acacia</i> will give a gelatinous, opaque white precipitate with solution of basic lead acetate. <i>Acacia</i> further tested for as in Group II or IV, or by adding a solution of tannin which gives a bluish black coloration.
Group IV Solution of sodium hydroxide.	A brownish yellow color on heating indicates <i>tragacanth</i> . A white cloudy precipitate indicates <i>acacia</i> .
Group V Solution of mercuric chloride.	A slight turbidity may indicate <i>dextrin</i> . A white precipitate may indicate <i>albumin</i> or <i>gelatin</i> .
Group VI Schweitzer's reagent (solution of cuprammonia).	If a concentrated water solution of the unknown is treated with this reagent and placed on a glass slide under a microscope, a delicate framework of cupric pectate is evident, showing <i>pectin</i> of fruit or vegetable origin present.

The Association of Official Agricultural Chemists<sup>1</sup> has adopted a method dependent upon precipitation with alcohol. A concentrated solution of the jelly, jam, or fruit juice is precipitated with 10 volumes of absolute alcohol, and the residue filtered off. This is dried and subjected to the Kjeldahl nitrogen determination.

<sup>1</sup> A. O. A. C., *op. cit.*, 156.

An optional method is to determine the nitrogen by Kjeldahl's method in the original product, when the presence of gelatin is indicated by the greater percentage of nitrogen which it contains.

*Gelatin in Chocolate.*—Onfrey<sup>1</sup> uses a modification of the picric acid method for the estimation of gelatin in chocolate. Five grams of chocolate are treated with 50 c.c. of boiling water, and 5 c.c. of 10 per cent lead acetate solution are added. The liquid is filtered and several drops of a saturated aqueous solution of picric acid added to the filtrate. If gelatin is present in appreciable amounts a yellow precipitate will be formed, but if only traces of gelatin are present the tannin of the cocoa combines with it forming an insoluble precipitate. In such cases 10 grams of the chocolate are extracted with ether to remove the fat, and the residue treated with 100 c.c. of hot water, 5 to 10 c.c. of a 10 per cent solution of potassium hydroxide, and 10 c.c. of lead acetate solution, and the mixture filtered. The filtrate is then treated with picric acid as above and gelatin even in traces is revealed by a turbidity or precipitation of gelatin picrate.

*Gelatin in Gums.*—Trillat<sup>2</sup> employed the formaldehyde process of Beckmann<sup>3</sup> for the estimation of gelatin in gums and other food substances. The material to be tested was dissolved in water, filtered, and evaporated to the consistency of a syrup. One c.c. of formalin was then added, and the evaporation continued until a thick pasty mass was produced. This residue was then taken up in hot water which dissolved out the gum but left an insoluble residue of formo-gelatin. After standing for 24 hours it was decanted, washed with boiling water, dried on the water bath, and weighed.

Vamvakas<sup>4</sup> employes Nessler's reagent for the detection of gelatin in gums. To 20 c.c. of the sample are added 4 c.c. of Nessler's reagent. In the absence of gelatin a gelatinous precipitate will be produced which is brownish gray in color, and remains in suspension for several days. If gelatin is present the precipitate will be dull gray in color, and subsides much more rapidly, especially when the gelatin is present to the extent of 20 per cent or more.

<sup>1</sup> P. ONFREY, *J. pharm. chim.*, **8** (1898), 7.

<sup>2</sup> A. TRILLAT, *Ann. chim. anal. chim. appl.*, **3** (1898), 401.

<sup>3</sup> See pages 473-474.

<sup>4</sup> VAMVAKAS, *Ann. chim. anal. chim. appl.*, **12** (1907), 139.

*Gelatin in Feeding Stuffs.*—Wagner and Schöler<sup>1</sup> have applied the tannin precipitation method to the estimation of gelatin in feeding-stuffs. Five grams of the material are boiled with 200 c.c. of water for 5 hours. The mixture is transferred to a 500 c.c. volumetric flask and when cool made up to volume with water and filtered. One hundred c.c. of the filtrate are treated by the Kjeldahl method for nitrogen. Another 100 c.c. portion is treated in a 250 c.c. volumetric flask with 40 c.c. of a 10 per cent solution of tannin (of known nitrogen content), made to volume, allowed to settle over night, and filtered. The nitrogen in 150 or 200 c.c. of the filtrate is then determined by the Kjeldahl method. The result, corrected for the nitrogen in the tannin solution, gives the amide nitrogen, and by deducting this from the total nitrogen of the filtrate the nitrogen as gelatin and other proteins is estimated.

The presence or absence of albumins may be ascertained by testing a portion of the filtrate in the 500 c.c. volumetric flask with acetic acid and potassium ferrocyanide. Gelatin gives no reaction with these reagents, but the albumins are precipitated. The xanthoproteic reaction may also be applied, when the presence of albumins is shown by a deep yellow or orange coloration. Gelatin will react negative or only very faintly to the test.

*Gelatin as a Glaze or Coating on Coffee.*—The Association of Official Agricultural Chemists<sup>2</sup> employs the tannin precipitation method in testing for gelatin used as a glaze or a coating on coffee. Such use is intended to improve the appearance of the coffee bean.

One hundred grams of the whole coffee are treated with 500 c.c. of water and allowed to stand with frequent stirring for 5 minutes. It is then filtered and one portion of the filtrate treated with a strong solution of tannic acid, another portion with Millon's reagent (see page 46), and a third portion boiled. In the presence of gelatin a precipitate will be formed in the first two tests, but not in the portion boiled. Egg albumin also gives positive tests in the first two cases, but differs from gelatin in producing also a coagulation upon boiling.

A further confirmatory test may be made by adding an excess of tannic acid to an aliquot of the filtrate, adding salt if necessary to secure flocculation of the precipitate, and without washing

<sup>1</sup> WAGNER and SCHÖLER, *Landw. Ver. Stat.*, **92** (1918), 171

<sup>2</sup> A. O. A. C., *op. cit.*, 272.



subjecting the paper and its contents to a Kjeldahl nitrogen determination. If no albumin or gelatin is present this will yield less than 10 mg. of nitrogen per 100 gram sample.

*An Emulsification Test for Gelatin.*—The determination of gelatin upon an entirely new principle was suggested by Winkelblech<sup>1</sup> in 1906. He observed that when gelatin was shaken with benzine there was formed a stiff emulsion consisting of gelatin, benzine and water, which separated from the water on standing, partly as a result of entangled air. If much gelatin is present the emulsion is very voluminous and lumpy, but when only a small amount of gelatin is present a number of bubbles of all sizes are observed resting on the surface of the water for a considerable time. Upon breaking, a permanent whitish ring of very small bubbles is left adhering to the walls of the tube.

Winkelblech applied this observation to the quantitative estimation of gelatin. He found that a heavy precipitate was obtained upon shaking with benzine 10 c.c. of a solution containing 0.234 gram of gelatin per liter. Even upon diluting this solution 10, 20, and 40 times, precipitates were likewise obtained. The limit of dilution at which the presence of the gelatin could be definitely established was by the use of 10 c.c. of a solution containing 0.06 gram per liter, or 0.06 milligram per 10 c.c. This was accomplished only by very energetic shaking, and by using a test tube or other container in which the area of contact between the two liquids would be small.

It became necessary therefore, in making use of the test with unknown solutions, only to dilute the samples until the same slight amount of precipitation occurred, and beyond which point no positive results could be obtained. If a small amount of acid is present the precipitate seems to be slightly diminished, while in the presence of a little alkali the reverse is true. Large amounts of either acid or alkali make the tests unreliable. Also if the dilute gelatin solution is allowed to boil for a few minutes the delicacy of the test is seriously impaired.

Besides benzine other hydrocarbons including kerosene, benzene, chloroform, and carbon disulphide may be used. It does not matter if the hydrocarbon is lighter or heavier than the water. If the former, the precipitate floats on the water; if the latter, the precipitate floats on the hydrocarbon. The test should not be relied upon in the presence of other colloids, as

<sup>1</sup> WINKELBLECH, *Z. angew. Chem.*, **19** (1906), 1953.



albumin, soap, water soluble starch, rosin dissolved in dilute alkali, etc., also give somewhat similar tests. The purity of the hydrocarbon used should be assured, as it also may contain impurities which give a faint test when shaken alone.<sup>1</sup>

Winkelblech explains the action observed by assuming that the violent shaking breaks the hydrocarbon into a large number of droplets which have the power of condensing the finely divided colloid particles upon their surface. These particles then coalesce to form aggregates and a rigid emulsion is formed. At the lowest dilutions a few large transparent fairly stable bubbles appeared which were filled with hydrocarbon except for a small air bubble. This appears as evidence that the wet colloid particles are able in some way to form surface films. In its essential aspects this theory is in complete harmony with Bancroft's theory of film formation in emulsification.<sup>2</sup>

Bancroft<sup>3</sup> has suggested that Winkelblech's method is in reality a test for interfacial substances (substances which adsorb the two immiscible liquids simultaneously, and therefore tend to pass into the dineric interface), and as such is capable of much wider application than has yet been made in the detection of colloidal solutions.

**4. Glue in Size and Miscellaneous Preparations.**—Gelatin in the form of an inferior grade of glue is commonly used as a size in the manufacture of paper, textiles, hats, etc. As other materials such as casein glue, vegetable glue, rosin glue and other preparations are similarly used it is sometimes necessary to distinguish between them. For differentiating animal glue and casein from the others in paper, Levi<sup>4</sup> recommends the biuret test. The paper is steeped for a few minutes in 2 per cent copper sulphate solution and then treated with a 5 per cent solution of sodium hydroxide, the latter being added by dropping directly upon the paper. If gelatin or casein are present a violet coloration is at once produced. In order to distinguish between gelatin and casein, Levi recommends the xanthoproteic reaction which reacts positive to casein but negative to gelatin. The test is carried out by merely moistening the paper with a drop of concentrated nitric acid, when, if casein is present, an intense yellow

<sup>1</sup> W. D. BANCROFT, *J. Phys. Chem.*, **19** (1915), 330.

<sup>2</sup> See page 214.

<sup>3</sup> W. D. BANCROFT, *loc. cit.*, 308.

<sup>4</sup> LEVI, *Papierfabr.*, **9** (1911), 365.

stain is produced. On adding sodium hydroxide the stain turns brown, or if ammonium hydroxide is added, the stain becomes orange. The xanthoproteic reaction cannot be used, however, in the presence of wood fiber, as the lignin in the latter also reacts with nitric acid giving the yellow stain. This may be avoided however, by scraping off the size, or extracting it with a solution of borax or an alkali, precipitating with acetic acid, and testing the dried precipitate with nitric acid as above.

Herzberg<sup>1</sup> identifies rosin in sizing material by the Raspail reaction, a rose or violet coloration being produced upon adding sugar and concentrated sulphuric acid. Methods of extraction with alcohol or ether he declares useless. Herzberg identifies an animal size by precipitation of its solution with tannin; by the yielding of a yellow or brown coloration with iodine in solution with potassium iodide; by the xanthoproteic reaction; by Millon's test; or by the biuret test. Of these the biuret test is preferred, as it gives an absolutely negative test with rosin. The test is best carried out under the microscope. Casein he distinguishes from gelatin in that the former reacts to the Adamkiewicz test, giving a red or violet coloration with glacial acetic acid and sulphuric acid.

Schmidt,<sup>2</sup> in testing for gelatin in textile dressings, regards the ammonium molybdate and the Nessler tests when taken together to be best suited for the purpose. In the presence of gelatin, ammonium molybdate yields a flocculent white precipitate which partially dissolves on heating but reappears on cooling. Nessler's reagent should be rendered feebly acid with sulphuric acid, the red precipitate filtered off, and the clear filtrate used for the test. This when added to a gelatin solution yields a white turbidity whether the solution is hot or cold. Ammonium salts do not interfere, but protein other than gelatin must not be present. These two tests Schmidt claims will detect 0.01 mg. of gelatin in 5 c.c. of solution, a quantity not detectable by the biuret or the tannin tests. The solution should be freed from fat and albumin by means of nitric acid, and alkaline solutions must be neutralized before applying the tests.

Herz and Barraclough<sup>3</sup> have pointed out that when wool or hair is boiled with water a substance is dissolved which gives the

<sup>1</sup> HERZBERG, *Chem. News* (England), **110** (1914), 19.

<sup>2</sup> SCHMIDT, *Farben-Ztg.*, **24** (1913), 97.

<sup>3</sup> HERZ and BARRACLOUGH, *J. Soc. Dyers and Color.*, **25** (1909), 274.

same reactions with tannin and the biuret test as gelatin. For this reason these tests cannot be used in testing for gelatin as a sizing material on woolen goods, fur, or any other animal fiber. Gelatin may ordinarily be distinguished from the wool product by the fact that the latter is precipitated from solution by normal or basic lead acetate solutions. Basic dyestuffs form insoluble lakes with wool products but acid or direct dye-stuffs do not form such compounds. The wool product may also be fractionated into three apparently distinct constituents. The first of these gives no precipitate with Night Blue, but is precipitated by a solution of 2 per cent tannin mixed with an equal volume of saturated sodium chloride solution. The second gives a precipitate with Night Blue which is dissolved by treating with barium hydroxide solution, but is reprecipitated upon adding either Night Blue or tannin salt solution, after the removal of the excess of the alkali. The third constituent also gives a precipitate with Night Blue, but this remains insoluble when decomposed with barium hydroxide.

The Technical Association of the Pulp and Paper Industry<sup>1</sup> does not attempt to distinguish gelatin from casein quantitatively but determines the total nitrogen, and makes a qualitative test for gelatin. A small portion of the paper is boiled with 10 c.c. of water in a test tube. The solution is decanted to another tube and cooled. Five c.c. of ammonium molybdate solution are added, followed by a few drops of nitric acid. The formation of a white amorphous precipitate indicates the presence of glue.

A quantitative as well as qualitative test for glue in papers was proposed by Cross, Bevan and Briggs,<sup>2</sup> based upon the monochloramine reaction which ammonia and amino groups of proteins were found by them to undergo in the presence of chlorine or a hypochlorite:

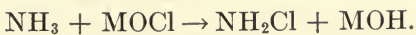

The chloramine reacts with iodides similarly to the hypochlorites:

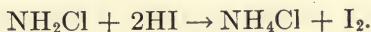

These reactions were utilized in the detection and estimation of gelatin in tub-sized papers as follows: The moistened paper is treated with chlorine gas and placed in a bath of 2 per cent solu-

<sup>1</sup> F. C. CLARK, "Paper Testing Methods," New York (1920), 21.

<sup>2</sup> C. CROSS, E. BEVAN, and J. BRIGGS, *J. Soc. Chem. Ind.*, **27** (1908), 260.



tion of sodium phosphate, previously heated to 45°C., for exactly 5 minutes. This treatment eliminates any interfering action that might result from iron compounds. The fragments are then removed from the bath and tested with potassium iodide and starch. A strong coloration will be shown when less than 0.5 per cent of gelatin is present. Large quantities of mechanical wood pulp in a paper will produce a faint chloramine reaction owing to traces of protein matter in the raw wood. For a quantitative determination the sheets of chlorinated paper are suspended in front of a fan and exposed to a full blast of air for at least 1½ hours. The paper is then torn up, placed in N/100 arsenite for at least one hour, and the excess of arsenite determined by titration with N/10 iodine. The proportion of chlorine taken up by gelatin under these conditions was found to be 15.4 per cent of its air-dry weight, therefore the weight of chlorine found divided by 15.4 and multiplied by 100 will give the percentage of gelatin per gram of sample taken. Comparisons of this method with the Kjeldahl determination of nitrogen show satisfactory agreement, as shown in the following table:

TABLE 57.—GELATIN IN PAPER

Paper	Gelatin by Kjeldahl method $N \times 6.53$	Gelatin by chlorine method
Note paper.....	7.1	7.1, 7.25, 7.4, 7.3
Typewriting paper.....	2.62	2.8, 3.0
Ledger paper.....	8.15	7.7, 7.7

Glue is occasionally found in mineral oils from carelessly glued casks. It may be detected as follows: 100 grams of the oil are shaken with boiling water in a separatory funnel and the aqueous layer run off into a measuring cylinder. An aliquot portion, 50 c.c., is filtered through a paper filter and evaporated to dryness on a water bath. If there is a residue it is extracted with three portions of 8 c.c. each of hot absolute alcohol which will remove any soap that may be present. If the residue contains glue the characteristic odor will be perceptible, and a confirmatory test may be made by adding tannic acid to its aqueous solutions. A heavy precipitate indicates glue.



## CHAPTER X

### THE EVALUATION OF GLUE AND GELATIN

I often say that if you can measure that of which you speak, and can express it by a number, you know something of your subject; but if you cannot measure it, your knowledge is meagre and unsatisfactory.

Lord Kelvin (1880)

The day is not far distant when glue and gelatin will be purchased on specification, and such a trade condition will necessitate the adoption of a uniform system of tests throughout the United States.

Fernbach (1906)

	PAGE
1. Present Methods of Evaluation.....	488
2. Primary and Secondary Tests.....	491
3. Diversity of the Proposed Tests.....	492
4. A Scientific Basis for Evaluation.....	495
5. A Rational System of Evaluation.....	499
6. Differentiation between Edible Gelatin and Glue.....	502
7. The Designation of Grade.....	502
8. Advantages of the Proposed System.....	505

There are very few substances which are extensively employed in the trades and the arts that offer so much embarrassment to either the layman or the chemist in defining, or specifying, or testing the quality or the purity as do gelatin and glue. Many factors contribute to this situation. Commercial gelatin and glue are by no means definite substances, and simple tests for purity are not available. Tests which are believed by one set of individuals or manufacturers to be comprehensive and indicative of certain fundamental properties are regarded as inadequate or untrustworthy by another set, and different tests are accordingly used by the latter which they believe to be more satisfactory. And the uses for which the various gelatins and glues are employed are so divergent and dissimilar that tests or analyses which may be entirely adequate for some given service would be quite useless as an indication of the value of the material for some other service.

The United States Bureau of Chemistry<sup>1</sup> in 1910 accepted

<sup>1</sup> U. S. Bureau of Chem., *Bull.* 109 revised (1910), 54.

Fernbach's<sup>1</sup> statement that chemical analysis gives little information in regard to the value of glue except in a few isolated and unimportant instances. The tests described by the Bureau of Chemistry Bulletin are moisture, ash, reaction, gelatin (nitrogen  $\times 5.56$ ), water absorption, viscosity (Engler), jelly strength (Lipowitz method), and melting point (by Cambon's fusiometer). Several of these tests are certainly obsolete. Nitrogen times a factor means nothing and is misleading, unless the sample be pure unhydrolyzed gelatin, which is almost never the case. Water adsorption varies with too many incidental factors, and has little significance. The Engler Viscosity test, the Lipowitz jelly strength test, and the Cambon melting point test have largely been replaced in most laboratories by more recent methods or apparatus.

### 1. PRESENT METHODS OF EVALUATION

The procedures in current use for the evaluation of gelatin and glue are based *primarily* upon the jelly consistency at low temperatures or the viscosity at high temperatures, and *secondarily* upon other incidental characteristics which depend upon the service for which they are designed. The Peter Cooper system of grading may be taken as typical of the American practice. Because this system was the earliest recognized attempt at glue grading in this country, and has been in continuous service since its inception in 1844, it is recognized as an American Standard to which other glues produced by other houses may be referred in terms that will be at least partially intelligible to the professional glue buyer. The various manufacturing houses use symbols, however, expressive of their several grades, which are more or less zealously guarded as a kind or relic of alchemic mystery, but the consumer is enlightened upon their meaning only to the extent of learning that the glue in question is the equivalent in jelly strength, for example, to the Peter Cooper grade  $1\frac{3}{8}$ , or the equivalent in viscosity to the Peter Cooper grade  $1\frac{1}{4}$ . Thus the Peter Cooper system may be looked upon as a standard for reference.

Alexander<sup>2</sup> has proposed the substitution of figures varying by ten points each for the symbols of Peter Cooper, and defined the

<sup>1</sup> R. L. FERNBACH, "Glues and Gelatins," New York (1907), 4.

<sup>2</sup> J. ALEXANDER, *J. Soc. Chem. Ind.*, **25** (1906), 158.

jelly strength in ounces and in grams at 10°C. (measured by his jelly strength tester), to which the numbers correspond. The viscosity test (as measured by his instrument) is also used by him.

The following table expresses his system of grading.

TABLE 58.—ALEXANDER'S GLUE STANDARDS

Standard	Peter Cooper grade	Viscosity 80°C.	Allowable variation in viscosity	Jelly strength in ounces 10°C.	Jelly strength in gm. 10°C.
10	.....	15½	±¼	...	....
20	.....	16	±¼	...	....
30	2	16½	±¼	...	....
40	1⅞	17	±¼	60	1701
50	1¾	18	±½	82	2324
60	1⅝	19	±½	104	2948
70	1½	20	±½	126	3572
80	1⅜	21	±½	148	4196
90	1¼	22	±¾	170	4820
100	1X	23	±¾	192	5443
110	1	24	±¾	214	6067
120	1 extra	25	±1	236	6691
130	A extra	26	±3	258	7314
140	.....	28	±5	...	....
150	.....	34	±8	...	....
160	.....	40	±12	...	....

Kahrs<sup>1</sup> in 1898 proposed a rather radical departure from the then existing (and still existing) indisposition on the part of glue manufacturers to grade their product by tests which were intelligible and valuable to the buyer. He urged the adoption of four tests, *i.e.*, adhesion, economic value, cohesion, and congealing point. By *adhesion* he meant the viscosity, which was expressed in terms of the weight of dry glue necessary to make up 100 unit weights of the liquid material of the proper viscosity for application in joint work. This figure Kahrs found to vary from 29 to 60. That is, in the highest grade of glue a 29 per cent solution, and in the lowest grade a 60 per cent solution, was required to give a liquid of the correct consistency, at about 60°C., for service in joining work.

<sup>1</sup> F. KAHRs, International Fisheries' Congress, Bergen, Norway, 1898.

The *economic value* was obtained by multiplying the adhesion value by the price per pound of the glue in question, and represented therefore the price of 100 pounds of the liquid glue ready for application. Thus at 18 cents for the highest and  $5\frac{1}{2}$  cents for the lowest grades (Kahrs' figures) the cost per 100 pounds of the liquid would be  $18 \times 29 = \$5.22$  for the highest grade and  $5\frac{1}{2} \times 60 = \$3.30$  for the lowest grade.

The *cohesion or strength* was measured by the crushing strength of the glue jelly made up at the concentration found under adhesion, and at a temperature of  $65^{\circ}\text{F}$ . (about  $18^{\circ}\text{C}$ .). The high temperature was used as it more nearly approached the temperature at which the glued joints would be used. This test was later substituted in part by an actual joint strength test.

The *congealing point* was measured as the temperature at which the glue, made up in the concentration indicated by the adhesion test, congealed to a jelly. This was found to vary from  $91$  to  $75^{\circ}\text{F}$ ., and the interval of  $16^{\circ}$  was divided into ten "setting grades."

The test of the glue was then expressed somewhat as follows:

TABLE 59.—KAHRS' GLUE TESTS

Number	Price per pound	Adhesion (wt. per 100 lb. standard liquid)	Economic value (price per 100 lb. liquid)	Cohesion (strength)	Congealing point
2942	18 cents	29.3	\$5.27	25	91.7
2924	$5\frac{1}{2}$ cents	57.8	3.18	15	77.5

There are many interesting points in such a system. The table will show that although the first glue costs more than three times the second, per pound, yet per unit volume of liquid ready to use it costs only six tenths more. But it is shown to be worth more in producing, at that dilution, a greater strength, and in setting at a higher temperature, *i.e.*, more rapidly at any given temperature. Such a system enables one to see at a glance exactly wherein the differences in the glues lie, and to form an intelligent basis for judging between them. It at least gets down to salient and understandable data, which is much more than can be said for some systems now in use.



Thiele<sup>1</sup> bases the commercial value of edible gelatin on its viscosity (Engler), melting point, and color value.

## 2. PRIMARY AND SECONDARY TESTS

There is a difference in opinion as to what test should be regarded as the most *fundamental*. In Germany the viscosity test proposed by Fels,<sup>2</sup> made by the use of the Engler viscosimeter at 35°C., seems to be in greatest favor. In Italy a combination of viscosity and melting point is used.<sup>3</sup> In France and England the viscosity test and the melting point test by Cambon's fusiometer are employed. In this country the jelly consistency or strength is probably more used than any other test, although the viscosity test is in favor in many houses, and the melting point test by various methods is used. The quality of the material and the price are primarily rated upon these tests—sometimes a single one, and sometimes a combination of two or more. Clayton<sup>4</sup> concludes that the "observations seem to show that whilst it would be rash to form a judgment on glue from a single test, the evidences afforded by a number may be irresistible. The experts' surest system appears to be, not to rely on single short cut tests of general quality, but to employ a number of methods, including any having special bearing on the prospective or present uses of the glue, and then to base his conclusions on a consideration of all the results together." And Alexander<sup>5</sup> who cites the above adds, "the truth of the matter is that the figures have a partial value, and then only to a glue expert." That is precisely the situation that the chemist should set himself to eradicate. Figures that mean little or nothing should be substituted if possible, by data that do mean something, and that persons other than glue experts may comprehend.

The *secondary* basis for glue or gelatin evaluation lies in many or few other tests which are employed to determine the *applicability* of the material for any special service. For example, where the glue is to be used in mechanical spreaders, the tendency to foam is undesirable, and the foam test indicates this tendency.

<sup>1</sup> L. A. THIELE, Personal Communication.

<sup>2</sup> J. FELS, *Chem. Ztg.*, **21** (1897), 56; **25** (1901), 23.

<sup>3</sup> V. L. CERRI, Report to Italian Military Aviation Board (1920).

<sup>4</sup> E. G. CLAYTON, *J. Soc. Chem. Ind.*, **21** (1902), 670.

<sup>5</sup> J. ALEXANDER, *loc. cit.*

If the glue is to be applied by hand, the foam test is of little or no significance. If the glue is for use on paper as a size or wall paper as a binder for the clay filler, grease should not be present in large amount, as otherwise little droplets of this substance form, making elliptical "eyes" or spots on the paper. In admixture with certain dyes the presence of acid or of alkali is not permissible as the dye would be affected in one way or another. Suitable tests must accordingly be made upon glues designed for such purposes. Gelatin for use in photographic films or in printing rollers must have high jelly strength; if used for food or medicinal purposes it must be free from harmful impurities; if used in making marshmallows or other emulsions, a high viscosity and foam are desirable. Such a list could be greatly extended, and the *adaptability* of any glue or gelatin for its several uses is largely determined by such *secondary* tests.

The influence which such properties should exert upon the selling price of the product should be proportional, however, only to the extra cost involved in manufacturing any specialized type of material, and on the laws of supply and demand. If an extra clear glue is required the consumer should be properly expected to pay for the extra cost of clarification and filtration, and such extra cost should properly be figured on a sliding scale, dependent upon the final color and clarity, to be added to the cost of the untreated glue of the corresponding grade. For the textile trades where precipitation with alum must not occur; for veneer glues where foam is very objectionable, and for all other trades requiring glues of specific properties, the price should similarly be based upon a sliding scale to be applied to the market price of the regular corresponding grade. Where no extra cost is involved in the production of a specific glue, then the sliding scale may apply according to the usual dictum of supply and demand, but *it would seem most expeditious to base all such variations upon a standard primary evaluation.*

### 3. THE DIVERSITY OF THE PROPOSED TESTS

The numerous methods that have been proposed for the testing of glue and gelatin for the purpose of evaluation have been described in detail in Chaps. VIII and IX, and need not be repeated at this place. A brief consideration of the merits of the procedures is, however, necessary to the intelligent understanding of the situation.

Recent researches upon gelatin have brought to light many relationships that should be incorporated into the scheme of primary evaluation. From the point of view of the chemist gelatin is a chemical compound, a pure protein, and glue is a mixture of gelatin with the products of gelatin hydrolysis, sometimes referred to as  $\beta$  gelatin, and other impurities in varying amounts. Commercial gelatin and glue should, therefore, from the standpoint of *chemical constitution* be primarily evaluated in terms of the proportion of pure unhydrolyzed gelatin which is contained in the material. From the point of view of the major glue trade, *i.e.*, the use of glue as an *adhesive*, glue should be evaluated in terms of the strength of the joint, produced under the most favorable conditions, which may be made with the material. Fortunately these two points of view,—that of the chemist and that of the joiner,—have been shown to be identical. The glue with the largest amount of unhydrolyzed gelatin produces the strongest joint.<sup>1</sup> In the primary evaluation of the material, therefore, one or the other of these two properties should be measured, or else some variable which has been found by repeated and exhaustive tests to be directly dependent upon these properties, and to express them correctly.

The proposed methods may be divided into physical tests and chemical tests. The latter aim in nearly all cases to precipitate out the gelatin and rate the material in accordance with the amount of nitrogenous matter so precipitated. An error by this procedure was shown<sup>2</sup> to lie in the fact that precipitation with alcohol, tannin, and saturated solutions of zinc-, magnesium-, and ammonium sulphate threw down not only the unhydrolyzed gelatin but also the proteoses. The actual value of a gelatin or glue has been found to be defined by the content of unhydrolyzed gelatin, and the adhesive strength of a glue is proportional to the gelatin: proteose ratio.<sup>3</sup> It is, therefore the gelatin alone, rather than the sum of the gelatin and the proteose that is the criterion for gelatin and glue grade.

It has been shown that by the precipitation of the protein with half saturated salt solutions (as above) the undegraded gelatin only is thrown down, and an accurate evaluation, based upon actual gelatin content, may be obtained. This operation appears

<sup>1</sup> R. H. BOGUE, *Chem. Met. Eng.*, **23** (1920), 197.

<sup>2</sup> *Vide* Chap. IX.

<sup>3</sup> *Vide* page 28.

to be a fundamental one (so far as a true division is possible of being drawn between protein and proteose) and when performed under conditions of exact control<sup>1</sup> (especially temperature and acidity) is capable of ready duplication. It seems therefore, in the absence of any more promising and fundamental procedure, that this should be regarded as the primary basis for evaluation.

The technical requirements in the laboratory, however, make it imperative that the testing should be susceptible of rapid and not too exacting manipulation. For this reason it becomes highly desirable that a physical test, or series of such tests, that may be made with rapidity and assurance should be found that parallel to a very close margin the relative evaluation that would result from the chemical examination described above.

Of the available physical tests that have been applied, the jelly consistency, the viscosity, and the melting point are the ones that have received most attention, and the first two are about equally divided in favor among glue and gelatin testers. The melting point, has not been so much used on account of the greater difficulty of manipulation.

The types of apparatus that have been devised for testing these properties are numerous, and each new method recognizes a possible source of error in older procedures and endeavors to correct it. The elimination of the error due to "skin formation" on the jelly in testing the jelly consistency has inspired a number of inventions. The shape and size of the container has brought forth others, until the most recent device of Sheppard<sup>2</sup> leaves little to be desired in the way of scientific perfection.

All kinds of devices have been utilized for measuring viscosity, from improvised pipettes and torsion viscosimeters to cans fitted with a small stopcock.

An indirect method making use of the property possessed by gelatin of mutarotation between the temperatures of 15 and 35°C., has been employed by C. R. Smith<sup>3</sup> with highly interesting results.

The actual adhesive strength has at times been utilized but it is so difficult to obtain accurately duplicatable results on account of the many uncertainties in the conditions of the test, and also

<sup>1</sup> *Vide* pages 26-27.

<sup>2</sup> *Vide* pages 378-9.

<sup>3</sup> *Vide* pages 413-15.



because of the expense of a machine for making such tests, that it has not gained favor except in a very crude way among joiners, and among scientific investigators. The tensile strength of a machined piece of glue of specified dimensions has been suggested, but has not yet been proven practicable.

#### 4. A SCIENTIFIC BASIS FOR EVALUATION

From among these physical tests, then, we are confronted with the task of making a selection, but we must keep in mind the imperative necessity, if our selection is to be altogether justifiable and sound, of utilizing only such a property as will conform to the more fundamental requirement of chemical constitution mentioned above.

Extensive tests have been made in the author's<sup>1</sup> laboratory upon the relations which the jelly strength, the viscosity, and the melting point bear to both gelatin content and to joint strength, and the data obtained show clearly that if the viscosity be held constant the gelatin content and joint strength will vary as the jelly consistency, while if the latter be held constant these properties will vary as the viscosity. But the jelly consistency and the viscosity are also shown to bear the same relation to the melting point, while the latter appears to define with precision the gelatin content or joint strength. Any method therefore, which accurately estimates the melting point, or which differentiates the glues in the same order as would result from the melting point test, should be a satisfactory basis for evaluation. In most glues and gelatins the viscosity and the jelly consistency are perfectly parallel functions, and a given jelly consistency will imply a definite viscosity, or *vice versa*, but there are many exceptions to this generality,—so many in fact that were we to use either the jelly consistency or the viscosity alone as a basis of evaluation, a large number of glues would be incorrectly graded. For example, a given glue of say 1¼ grade (Peter Cooper) and 22 viscosity (Alexander) may show a joining strength of say 2,000 pounds per square inch. The same grade with a viscosity of 23 may show perhaps 2,200 pounds. Or a grade of 1⅜ and a viscosity of 22 may show 1,800 pounds. Obviously, if evaluation were correctly based upon jelly consistency, the first two examples should show the same strength, and if

<sup>1</sup> R. H. BOGUE, *loc. cit.*

based upon viscosity, (at 60–80°C.), the first and third examples should be identical.

The melting point appears to be controlled by both the jelly consistency and the viscosity, and would therefore, in the cases cited, be highest in the second, intermediate in the first, and lowest in the third, which is also the order of the strength. The melting point test seems in fact to be the most readily available and practicable test as the basis for glue and gelatin evaluation.

There are many methods by which the melting point may be measured, but most of these are inexact and on account of the time required for the gel and sol forms to come to a true equilibrium, the procedures intending to measure the precise temperature of melting of the jelly, or setting of the sol, are apt to be inaccurate. In an attempt to find a more rapid and satisfactory method for measuring this property, the author observed that by plotting the curve of viscosity at regularly decreasing temperatures, and extrapolating to the temperature where the viscous flow would be *nil*, the figures derived corresponded remarkably well with those derived by several other methods of melting point determination, both direct and indirect. But it was further observed that the same *order of differentiation* of the glues was obtained by merely taking the viscosity readings at a low temperature (32 to 35°C.). This order was, in most cases, the same as the order of viscosity at 60°C., and the order of jelly consistency at 15°C., but in all of those glues in which the viscosity was abnormal to the jelly consistency, or *vice versa*, the viscosity at 32 to 35° was found to give a value intermediate between those two properties; to correspond with the true melting point; and to be precisely indicative of the gelatin content and the joint strength of the product, which was not true of any other test.<sup>1</sup>

The most satisfactory means for making this low temperature viscosity test was found to be by the use of the MacMichael viscosimeter. The advantages attendant upon the use of this instrument were found to be as follows: (1) The tests could be made very rapidly. In fact, if the glues are ready in a water

<sup>1</sup> The temperature of 32 to 35° was shown by C. R. Smith and by R. H. Bogue to be especially significant. Smith found this to be the temperature above which the gel form could not exist, and Bogue found this to be the temperature above which evidence of plastic flow could not be observed. See pages 116 and 211.

bath at the proper temperature,<sup>1</sup> the viscosity tests may be made at the rate of about one in a minute. (2) The instrument is a standard make, obtainable anywhere, so that its adoption would eliminate the multitudinous array of pipette and other forms of viscosimeter now in use. This would make for standardization which is so sorely needed in glue testing practice. (3) The instrument is especially well adapted to a rapid conversion of the readings into the absolute degree of viscosity, the centipoise. The calibration of the instrument takes but a short time, and a conversion curve, which is a perfectly straight line, may be plotted, so that the MacMichael degrees may be read off in centipoises by a mere glance of the curve.<sup>2</sup> The centipoise unit as a standard for expressing all viscosity measurements cannot be too strongly urged. The value would be entirely independent of the size of torsion wire used, or the speed of rotation of the cup, and expresses almost exactly the specific viscosity of the material, water taken as unity, at 20°C. (4) Under the conditions at which the instrument would be used in glue testing, the errors, which are of considerable magnitude with many types of viscosimeter, *e.g.*, the development of turbulent flow, the increasing loss in head during the measurement, inconstant and faulty drainage, the change of temperature during measurement, the abnormal values obtained when insoluble material, as zinc oxide, is present, etc., are almost entirely eliminated. The straight line nature of the conversion curve also makes for greater accuracy in computing the absolute viscosity from the instrument reading, and by a proper adjustment of the wire and the speed of rotation the absolute viscosity in centipoises may be read directly.

Different grades of glues and gelatins normally vary in water content from about 10 to 17 per cent, the higher grades retaining the larger amount of water. Of even greater importance in evaluation is the ability of any given sample of any grade to take up or lose water according to the humidity and temperature

<sup>1</sup>The glues, after soaking in the proper amount of water (see below) should be warmed to 60°C., and then allowed to cool to 35 degrees before taking the viscosity. If they are not thus preliminarily heated to 60° the readings will be erratic, and unreliable, no matter how tested.

<sup>2</sup> See Appendix, page 608, for the conversion of MacMichael degrees to centipoises.

of storage. Under ordinary conditions, glues have been found to vary in water content from 9 to 18 per cent from this cause alone. It is obvious, therefore, that a 20 gram sample may contain between 16.4 and 18.2 grams of dry glue, and since this is made, for the viscosity test, to 100 grams with water,

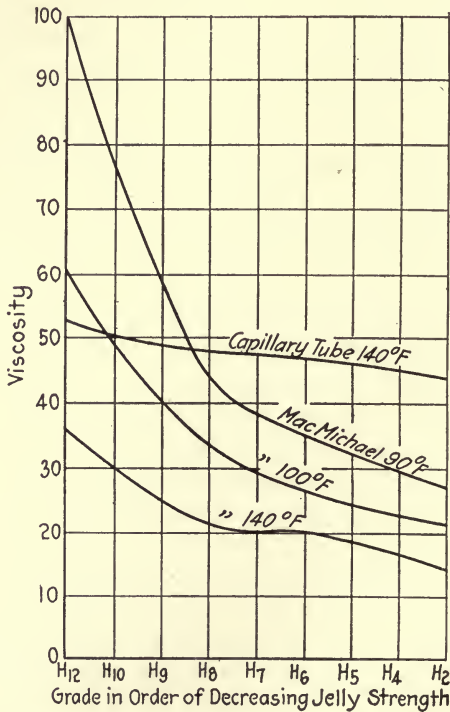

FIG. 99.—The relation of viscosity to jelly strength. Hide glues.

the percentage of dry glue used in the tests would vary between 16.4 and 18.2 per cent. This is sufficient to modify very seriously the viscosity or any other test made which varies with the concentration. In order to eliminate this uncertain variable, it is necessary to make a moisture determination before weighing up the samples for further tests, and it is suggested that the amount of glue to be used for the viscosity test be stipulated as the equivalent of 18 grams of dry glue made up to 100 grams with water.



A comparison of the viscosities as determined by the MacMichael instrument and the capillary tube (of the type described

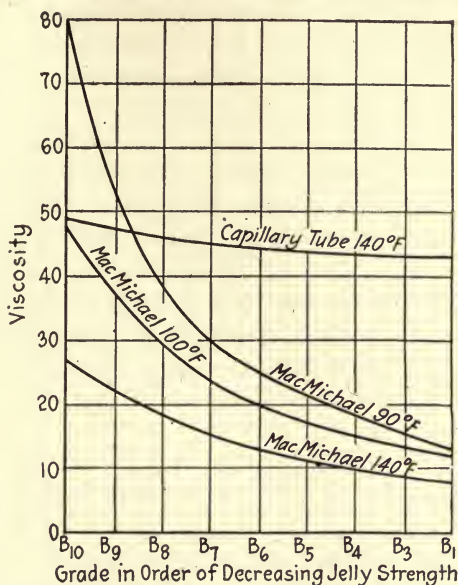

FIG. 100.—The relation of viscosity to jelly strength. Bone glues.

by Fernbach) for nine grades each of hide and of bone glues is shown graphically in Figs. 99 and 100.

## 5. A RATIONAL SYSTEM OF EVALUATION

Our discussion has shown, therefore, that both the gelatin content of a glue or gelatin, and also the joint strength of a glue, may be correctly indicated by a melting point determination, while neither may be correctly assumed to be, in all cases, proportional to either the jelly consistency or the viscosity at 60°C. alone. Inasmuch as the primary evaluation of the material should be based upon some fundamental and scientifically selected property or properties, it seems that gelatin content and joint strength should be chosen. It is especially happy that these two properties are parallel. Since the *melting point* has been shown to indicate the gelatin content and the joint strength, it seems that this determination, either directly or indirectly made, should be selected as a measure of the fundamental constitution and properties of the material. The measurement

of the *viscosity of an 18 per cent solution*, dry basis, at 35°C., by means of the MacMichael viscosimeter has been shown to be especially well adapted as an indirect estimation of the differentiation of glues and gelatins in the order of their melting points, and is accordingly recommended as the basis for the primary evaluation of these products.

If this test be accepted for the above stated purpose, it follows that the tests for jelly consistency and for viscosity at 60°C. are no longer of service for *primary* evaluation, and may be safely discarded *as such*. They may however, be of great value in secondary evaluation, *i.e.*, in determining the adaptability of a given glue to a given service. For example, the jelly consistency would be of value in selecting glues for printers rollers, and the rapidity of setting of the jelly as well as the viscosity at working temperatures would be desirable data for the wood-working industry.

Another test which recent investigation has shown to be of considerable importance in determining the properties of a glue or gelatin is the *hydrogen ion concentration*.<sup>1</sup> If the pH value is 4.7 the viscosity, swelling, etc., are low, and the product nearly insoluble. On either side of this point these properties increase very considerably, attaining their maximum, on the acid side at pH 3.5 and on the alkaline side at pH 9.0. At greater acidity than pH 3.5 or at greater alkalinity than pH 9.0 these properties again decrease. The pH value indicates therefore, not only the reaction of the material, and the degree of acidity or alkalinity, but also the proximity of the substance to the points of maximum or minimum properties. The measurement may be made by either electrometric or colorimetric means.<sup>2</sup> One per cent solutions are best used in either case, and the results expressed in terms of pH to the nearest tenth.

The methods that may be employed for the estimation of the secondary properties should likewise receive attention that the results may be expressed in uniform terms. The *jelly consistency* test is perhaps most conveniently made by the use of the instrument described by the Forest Products Laboratory<sup>3</sup> and expressed

<sup>1</sup> See J. LOEB, *J. Gen. Physiol.*, **1** (1918-19), 39, 237, 363, 483, 559; **3** (1920-21), 85, 247, 391. Cf. Chap. V.

<sup>2</sup> See W. M. CLARK, "The Determination of Hydrogen Ions," Baltimore, 1920.

<sup>3</sup> Forest Products Laboratory. see pages 374-5.

in millimeters of depression, although for some more exacting requirements, as in the selection of gelatin for photographic purposes, the more elaborate and scientific method of Sheppard<sup>1</sup> may be used to advantage. The *viscosity* at working temperatures, 60°C., may be made with the MacMichael viscosimeter upon a 20 per cent solution and the results expressed either in centipoises, or, following the suggestion of Kahrs, in pounds of dry glue which, when made up to a weight of 100 pounds with water, will produce a solution of a given standard viscosity at 60°C., as, for example, 600 centipoises. The *foam test* may be made upon 200 c.c. of a 20 per cent, solution in a standard glass, by means of an egg beater turned at a stated velocity of about four revolutions per second for 30 seconds, and measured after 10 seconds as millimeters of foam. The *grease test* may usually be made with sufficient satisfaction by making a streak of the glue, to which a dye, as turkey red, has been added, on a sheet of paper. Better still, the glue may be mixed with the calsumine or color base with which it is intended to be used, and streaks made on paper. The appearance may be specified according to the information desired. The form of the product, as flake, sheet, ribbon, foil, or ground, should be noted. If the glues have been treated to produce a clear light product, the degree of clarity and color should be indicated. This may usually be done, with sufficient satisfaction, by such terms as light, clear, medium, amber, etc., or by numerical designations as No. 1, No. 2, etc. Exact color data are best obtained by the elaborate instrument of the Eastman Kodak Co. If the glue is colored, or crazed, or presents any particular property it should be mentioned. The *odor* should be noted in the warm solution, and a strong or sour odor should not develop, in good glues, within 48 hours at 30 to 40°C.

In some cases special tests will be required as for *moisture*, *ash*, *precipitation with aluminum salts*, etc., and in the case of gelatin for edible purposes *copper*, *zinc*, *arsenic*, and *sulphur dioxide* may be determined, and in some cases qualitative tests for *preservatives* are necessary. These are made in accordance with the customary scheme for the examination of foods, as set forth in the official publications of the Association of Official Agricultural Chemists,<sup>2</sup> and need not be repeated here.

<sup>1</sup> S. E. SHEPPARD, see pages 378-9.

<sup>2</sup> Association of Official Agricultural Chemists "Methods of Analysis," 1920, 147. Cf. Chap. IX.

For the purpose of fixing an abstract valuation, or for the estimation of tariff duties on imports, the primary evaluation only need be made.

#### 6. DIFFERENTIATION BETWEEN EDIBLE GELATIN AND GLUE

The methods in common use for distinguishing between edible gelatin and glue are based upon a few tests that are admittedly inadequate. The material is examined for copper, zinc, and arsenic, the maximum permissible in edible gelatin being 30, 100 and 1.4 parts per million respectively. The total ash is determined, the assumption being made that a glue is usually much higher in ash than a pure gelatin. The jelly consistency is noted, it being assumed that a glue will show much lower values for this property than gelatin. And the general appearance, color, and odor are noted, only reasonably clear and perfectly sweet gelatin being passed favorably. Sulphur dioxide is sometimes determined, but its presence is permitted in reasonable amounts. A bacteriological examination might be of value as an additional test, but many instances have been met where a gelatin gave off an offensive odor, but was found to be practically sterile. In such cases the decomposition had obviously taken place at some stage in the manufacture, but had subsequently been stopped, probably by the addition of a germicide. A periodical inspection of the care and sanitation exercised in the several steps of manufacture and in the selection of the stock used, would probably be more valuable as a basis for passing upon gelatin than any chemical or other tests upon the product that could be made. Provided, however, that a gelatin passed the requirements as an edible product, then its evaluation as a gelatin should be determined primarily, as in the case of glues, upon its content of the unhydrolyzed protein, or which has been shown to be the same, upon the melting point, or viscosity at 35°C.

#### 7. THE DESIGNATION OF GRADE

The grade designation of the product, as ascertained by the primary evaluation, may conveniently be expressed by consecutive numbers, 1, being the lowest, following the name or initial letter of the type or product. Thus hide glues may be designated



as Hide glue No. 1, Hide glue No. 2, or H<sub>1</sub>, H<sub>2</sub>, and so on up to perhaps H<sub>15</sub>, and bone glues as Bone glue No. 1, or B<sub>1</sub> to Bone glue No. 15 or B<sub>15</sub>. If the primary evaluation is measured, as suggested, by a determination of the viscosity in centipoises of an 18 per cent solution, dry basis, at 35°C., then H<sub>1</sub> or B<sub>1</sub> would correspond to a viscosity of less than 20 cp., and H<sub>15</sub> or B<sub>15</sub> to above 150 cp. The arrangement might well be along the following lines:

TABLE 60.—DESIGNATION OF GRADE

Designation	Viscosity of an 18 per cent solution, dry basis, at 35°C., in centipoises	Designation	Viscosity of an 18 per cent solution, dry basis, at 35°C., in centipoises
H <sub>1</sub> or B <sub>1</sub>	Below 20	H <sub>9</sub> or B <sub>9</sub>	90 to 99
H <sub>2</sub> or B <sub>2</sub>	20 to 29	H <sub>10</sub> or B <sub>10</sub>	100 to 109
H <sub>3</sub> or B <sub>3</sub>	30 to 39	H <sub>11</sub> or B <sub>11</sub>	110 to 119
H <sub>4</sub> or B <sub>4</sub>	40 to 49	H <sub>12</sub> or B <sub>12</sub>	120 to 129
H <sub>5</sub> or B <sub>5</sub>	50 to 59	H <sub>13</sub> or B <sub>13</sub>	130 to 139
H <sub>6</sub> or B <sub>6</sub>	60 to 69	H <sub>14</sub> or B <sub>14</sub>	140 to 149
H <sub>7</sub> or B <sub>7</sub>	70 to 79	H <sub>15</sub> or B <sub>15</sub>	150 to 159
H <sub>8</sub> or B <sub>8</sub>	80 to 89	etc.	

Obviously the highest grades would be attained only by the very pure gelatins, while only the material that was exceedingly poor would reach the lowest designation. Both classes of glues, *i.e.*, the hide and bone types, would be rated upon the same standard, but the initial letter or name would serve the desirable purpose of differentiating between the type of stock used. Edible gelatins could be referred to, if desired, as G<sub>12</sub>, G<sub>14</sub>, etc., but the numerical designations should always refer to a standard viscosity, or other value fixed as the primary standard for evaluation.

The laboratory test sheet would appear as follows:

## GLUE AND GELATIN TEST SHEET

Date.....

Lot.....

Designation		Physical tests						Chemical tests				Remarks			
Number	Grade	Viscosity in centipoises 35°C. 18 per cent Sol.	pH 1 per cent Sol.	Jelly consistency m. depression, 10°C. 20 per cent	Foam m.m. 20 per cent Sol.	Grease	Appearance	Odor	Moisture, per cent	Ash, per cent	Copper, p.p.m.		Zinc, p.p.m.	Arsenic, p.p.m.	Sulphur dioxide, p.p.m.
49440	H <sub>7</sub>	72	5.7	4.2	14	.....	dark, flake	sweet	....	....	..	..	..	....	.....
50214	H <sub>4</sub>	46	6.9	8.1	28	.....	brown, flake	sour	....	....	..	..	..	....	.....
46621	B <sub>9</sub>	90	3.7	4.1	..	.....	No. 1 sheet	sweet	....	....	..	..	..	....	No. ppt. with alum
46602	B <sub>1</sub>	17	4.9	liquid	8	present	crazed, flake	strong	10.4	....	..	..	..	....	.....
80441	G <sub>13</sub>	130	6.8	2.1	10	absent	light, ground	sweet	16.2	1.82	10	20	0.0	51	O.K.
59286	B <sub>7</sub>	78	5.4	..	13	.....	white, flake	sweet	....	8.7	..	..	..	....	.....
70222	G <sub>15</sub>	156	7.1	1.2	..	absent	amber, ground	sweet	17.3	3.31	10	220	7.0	270	technical only

Performed by.....

Approved by.....

Chemist

### 8. ADVANTAGES OF THE PROPOSED SYSTEM

The advantages of such a system, or of any other that secures a real standardization based upon fundamental and scientific principles, are strikingly apparent. Where the jelly consistency is taken as the basis for determining grade, a set of "standard" glues must be maintained, and in the course of a few years these standard types, through occasional renewal, must inevitably alter. Furthermore, the curves for the jelly consistency of various glues at varying temperatures are not parallel, but a glue that is weaker than the standard at 10°C. may be the stronger at 15°. There is surely no good reason why the tests would be made at one temperature in preference to any other, but the decision upon this very arbitrary point determines the rating which a glue may receive by the current methods.

Mention has already been made of the diversity of instruments used in making the viscosity test, and the impossibility, without profound instrumental corrections, of expressing the readings obtained in terms of absolute viscosity, or any other kind of viscosity that will be intelligible to a person using any other instrument.

And most important, the figures obtained by the jelly strength and the viscosity at high temperature methods do not give data which are invariably expressive of any fundamental property.

These objections the proposed changes seek to remedy. The primary evaluation involves the use of no arbitrarily selected "standard" glues, but gives results that are in themselves complete without reference to any other hypothetical product. The use of a standard instrument which readily permits of the employment of absolute degrees enables the readings to be universally understood, and the data obtained *are* indicative of fundamental properties of the material.

The grade designation is simple and very easily understood. The letter referring directly to the type of stock, and the number to the absolute viscosity, reduces to the vanishing point any mystery connected with glue grades, and enables the layman to define a glue with nearly the same degree of intelligence as may be exercised by the expert.

## CHAPTER XI

### THE USES AND APPLICATIONS OF GLUE

Materials are made one from bullish glue.  
Lucretius (About 50 B.C.)

	PAGE
1. The Handling of Glue.....	506
Glue Room Economy and Technology.....	506
Losses in Glue Due to Overheating.....	510
The Bacterial Decomposition of Glue.....	515
2. Glue as an Adhesive.....	517
The Conditions Affecting the Adhesive Strength of Glue.....	517
Methods of Making the Adhesive Strength Test.....	526
The Selection of Glues for Joint and Panel Work.....	534
The Application of Glue as an Adhesive.....	536
3. Glue as a Sizing Agent.....	538
The Sizing of Paper.....	538
The Sizing of Textiles.....	542
The Sizing of Wooden Containers.....	544
Glue as a Size in Paints and Calsomine.....	544
4. Glue as a Binding Agent.....	545
5. Glue as a Colloidal Gel.....	547
6. Glue as a Protective Colloid.....	550

To discuss adequately all of the uses to which glue has been put in recent years would necessitate a complete volume in itself, and in the end would not serve a highly important purpose. The effort is made, therefore, in the present chapter rather to consider in some detail the principles entering into the use of glue as an adhesive, and to make clear the essential characteristics of the employment of glue, and its selection for service, in several of the other major uses to which it is put. No attempt is made at an exhaustive treatment, but some of the most important qualities entering into the selection of glue for its several classes of employment are presented.

#### 1. THE HANDLING OF GLUE

**Glue Room Economy and Technology.**—There is in common practice in many glue rooms so much waste of material, so much loss of energy, so much ignorance of the basic principles



of glue handling, that the executives of every glue-consuming plant would do well to take steps to assure themselves positively whether such practice prevails in their own domain. While the trained mechanical or electrical engineer is employed to develop modern efficiency and to scrap unsound practice in other departments of the plant, the glue room foreman has been left, for the most part, severely alone to rule over his province with whatever of business or scientific efficacy or of indifference he may elect. Since the average glue foreman has learned his trade at the hands of older glue foremen it is not surprising that progress has not been as rapid as should otherwise have been expected in this department.

The only way to overcome this hereditary prejudice is by a system of deliberate constructive education of the glue workmen. Not by means of books: Technical or scientific literature makes little impression, but by the employment of a few comparative tests which he may see and appreciate. A few of the special precautions that should be introduced are set forth in the following paragraphs.

*Preparation of the Batch.*—Many glue workmen make up their batch of glue by measuring out a number of buckets or barrels of glue and adding to that a number of buckets or barrels of water. This procedure may result in a considerable variation in the concentration of the liquid glue resulting. Glue is marketed in a number of different forms: As sheet glue, flake glue, ground glue, etc., and each of these in turn may be made in thicknesses varying from about a fiftieth to a quarter of an inch. Where the glue is made very thin, a 12 quart pail full of the flake will weigh only about 6 pounds, while in the very thick cut material the same volume will weigh up to 15 pounds. In the case of ground glues the variation may be from about 12 to 21 pounds. Obviously, if a foreman who had been using a medium thick cut glue was supplied with a thin cut material, his pail, now holding a smaller weight, would measure off for him a smaller concentration for his liquid and, if the glue was of the same grade as formerly, all of the tests resulting would of course be low.

But even in the measuring out of glue from the same barrel the weights are apt to vary as much as two pounds in a 16 quart pail, which shows that consistent work cannot be accomplished by measuring, even under the most favorable conditions. The optimum concentration by weight should be determined

once for all for a given grade of glue and a given service, and it should then be insisted upon that all batches should be made up by weight: so many pounds of glue to so many pounds of water.

There has been no standard of optimum consistency or body of a glue that would produce the best results yet proposed.<sup>1</sup> Each house has its own conception upon this point. In the absence of more definite information, however, it is safe to say that many glue workmen use solutions of too high a viscosity. The glue is too thick oftentimes to properly penetrate the pores of the wood, and at the same time it sets too rapidly. A higher dilution, keeping the temperature at 60°C., would result many times in better penetration, slower set, and in general more satisfactory results, in addition to lowering the cost per square foot of area covered. A soft porous wood cannot, however, stand as great a dilution as can a denser wood, on account of the rapidity with which the thinner solution would be soaked up in the former instance.

In making any test upon the spreading capacity of a glue, attention must be given, not only to the actual weight of glue in a given weight of water, rather than a volume relation, but also very carefully to the temperature of the test. The viscosity increases very rapidly with every decrease in temperature, and while a 40 per cent solution, for example, will produce a desirable viscosity at 70°C., a 35 per cent solution would be sufficient at 60°, and if the temperature were allowed to go to 40° a 25 per cent solution would produce the same consistency. These tests are best taken always at 60°C.

*Soaking the Glue.*—Unless special precaution is taken to insure the complete covering of the glue by the water during the soaking process, some of the glue very often will extend above the water and not become softened. In the case of thin cut bulky glue, this is frequently the case, the water sometimes covering only half or less of the material. Upon warming a batch of glue prepared in this way the unsoaked portion will resist the action of the warm liquid and a greatly prolonged heating, or an excessively high temperature, is necessary to bring it all into solution. And such heating has been shown to result in extensive loss due to the hydrolyzing action of the water.

To overcome this difficulty the glue may be added in portions, the first portion being swollen before the second is added, or the

<sup>1</sup> See pages 519-20.

whole mass may be turned over, the top being placed on the bottom. In the case of ground glues the entire batch of glue should be stirred into about three quarters of the water required, and after soaking for a time the balance of the water added. This procedure prevents any of the light flakes from floating on the water and so not being properly soaked.

The temperature of the water should not be high, for above 20°C. the bacteria may become active. A temperature near the freezing point does no harm but an actual freezing of the swollen glue is probably harmful. If flake glue, or any very thick cut material, is used, the glue should soak for 10 to 12 hours, but if ground glue is employed, an hour or two is usually sufficient. In either case the flakes of glue should be completely swollen, and not show any hard places, as these will not be easily dissolved.

The water used should be as pure as is practicable to obtain. Acids or alkalis, dissolved salts, or suspended material in water each exert an effect upon the gelatin or other constituents of the glue, and undesirable results often may be traced to this source. The bacteria in contaminated water may be the cause of unusually rapid spoiling of a batch of glue.

*Melting the Glue.*<sup>1</sup>—Heat may be applied to the swollen glue in a number of ways. The most advantageous method, however, is to apply steam to an outer water jacket in which the glue container is placed. The glue should be stirred slowly during solution, and the temperature not allowed to exceed 65°C. The water in the outer jacket should not at any time exceed 70°C., and after solution is complete the temperature in both sections should be adjusted to 60°. A thermometer is indispensable, for without its use the temperature cannot be correctly gauged or controlled. The kettle should be covered to prevent evaporation, and the glue is best delivered into the workmen's pots by means of a cock placed near the bottom of the kettle. Only that amount of glue which will be used within two or three hours should be kept in the glue kettle. Properly soaked glue may be brought into a condition ready for use in a few minutes, and the saving in the strength of the glue warrants this procedure.

Another method of operation that is employed in some plants is to make up the glue into the form of a concentrated jelly, and to distribute this jelly to the workmen as needed. The workmen add a given amount of water to a given weight of

<sup>1</sup> See pages 510-15.



jelly, warm it over their bench heater, and it is then ready to apply. While this procedure reduces to a minimum the loss due to prolonged heating, it produces conditions which, unless very carefully controlled, are favorable for the rapid development of bacteria, and large batches of jelly are apt to spoil before being used. If the jelly is kept in an ice box this danger is averted, and very satisfactory results may be secured.

*The Application of the Glue.*<sup>1</sup>—After due consideration has been given to the concentration of the glue solution to be used for a certain work, the joiner must see to it that the joint is true, that the temperature of his glue is correct, that the temperature of the wood is correct, *i.e.*, warm but not hot; and then apply his glue quickly, rubbing it in as if he were painting it; apply the glue to both sections of wood in the joint, rub the joint to squeeze out as much of the excess glue as he can; and apply the pressure quickly and uniformly before the glue can have time to set. It has been shown that the most favorable pressure is about 200 pounds to the square inch of glued surface, but in practice only about 30 pounds are ordinarily employed. The joint should then be placed in a warm dry place and allowed to remain undisturbed for 8 to 12 hours. It is then safe to remove the pressure, but the maximum strength is not developed for several days.

**Losses in Glue Due to Overheating.**—It was not many years ago that it was a common practice among joiners and cabinet makers to procure the highest quality of glue, and boil it down to obtain a particular consistency which was regarded as most desirable. They argued that in order to do the best work a glue must be of the highest grade, but that such glues, on the other hand, were too thick to spread well at the dilutions they regarded as necessary, and also chilled too quickly. It therefore became common practice to cook the material until it did possess the desired qualities.

That there might be some justification for such a practice would be inferred from a paper by J. Herold.<sup>2</sup> He made the highly interesting statement that although the protein gelatin is the gelatinizing constituent of gelatin, and that the best gelatin contains the largest amount of this unhydrolyzed protein, yet that gelatin in glue is actually a drawback to its adhesive

<sup>1</sup> See pages 517–26.

J. HEROLD, *Chem. Ztg.*, **35** (1911), 93.



power, the best glue containing no gelatin, but in its place a non-gelatinizing proteose which may be made from the gelatin either by the action of alkalies, or by *prolonged heating with water*. He actually considers a low melting point, a low jelly strength, and a low viscosity as the *desiderata* for a high grade glue. Just what adhesive and other properties would be revealed by a substance containing say 90 per cent or more of proteose, obtained by the partial hydrolysis of gelatin, cannot be stated, because such a substance has not yet been, with certainty, prepared and tested. In all ordinary hydrolyses of gelatin, either by the action of acids, alkalies, enzymes, or water alone, the hydrolytic cleavage produces peptones in abundance, as well as proteoses, and in many cases the amino-acids, ammonia, etc., are likewise formed. And in all of these cases the adhesive strength is found to decrease proportionally to the extent of the hydrolysis, or in other words to be directly proportional to the content of unhydrolyzed gelatin.

A number of experiments have been performed in the author's<sup>1</sup> laboratory which illustrate very strikingly the decrease in strength which is brought about by the prolonged heating of a glue. Samples were made up in the usual way by the use of one part of glue to two and a half parts of water, and were heated for 12 hours in a water bath maintained at a temperature of 80°C. (176°F.) All loss in water due to evaporation was made up each hour. At the beginning of the operation, and at the end of 2, 4, 8, and 12 hour periods, portions of the glue were removed and applied to maple blocks which had been very carefully surfaced, and the glued joints subjected to a uniform pressure of 200 pounds to the square inch by placing between the parallel plates of a universal testing machine. After 16 hours they were removed, allowed to set for a week, and then carefully sawed to exactly 4 square inches glued surface, and sheared apart. The data obtained show very forcibly the serious loss due to prolonged heating, for the value of the glue dropped approximately one grade for each 2 hours of heating, or from a very high to a very low hide grade in 12 hours. In actual figures the loss in strength averaged about 85 pounds per square inch per hour, or about 1,000 pounds per square inch in the twelve hours. Differently expressed, the loss in strength amounted to more than 5 per cent of the original

<sup>1</sup> R. H. BOGUE, *Chem. Met. Eng.*, **23** (1920), 201.

strength per hour of heating, or to 67 per cent loss in the 12 hours. The curve expressing the decrease in strength is shown in Fig. 101.

This is not an exceptional case, for many other investigators have found somewhat similar results. For example, Linder and Frost<sup>1</sup> working at the somewhat lower temperature of 150°F. (65.5°C.) obtained a decrease in strength of from 30 to 45

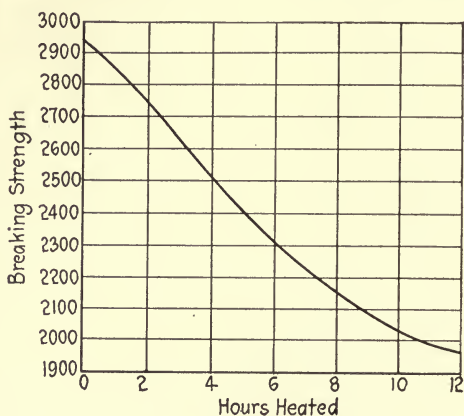

FIG. 101.—The effect of heating a high-grade glue in solution upon strength

per cent on heating a glue for 20 hours. The United States Forest Service<sup>2</sup> has conducted similar tests. Solutions of a high grade joint glue and a veneer glue were heated for 48 hours at 104, 140 and 176°F. (40, 60 and 80°C.) and tested every few hours during this period for strength and viscosity. "In the first 7 hours of heating at 176°F. the veneer glue lost approximately one-half its joint strength, and the high grade joint glue weakened almost as much. The greatest loss in the strength of the glue joints occurred at this temperature. In the solutions kept at 104° there was a sudden drop in the strength of the joints made with the high grade glue after 31 hours of heating, due possibly to a combination of bacterial and chemical action. The veneer glue joints showed a more gradual decrease at this temperature. The most favorable of the three temperatures used was 140°, but even at this temperature an appreciable weakening in both glues was noted at the end of 7 hours, and longer heating caused greater loss." The viscosity of the two glues decreased rapidly throughout the experiment.

<sup>1</sup> LINDER and FROST, *Eng. News*, **72** (1915), 178.

<sup>2</sup> U. S. Forest Service Technical Notes 104 (1920).

Consider for a moment what these losses mean in dollars and cents. Taking the price of the highest grade of glue at about 46 cents per pound (in barrel lots), the price of the grade to which it was brought by twelve hours of the heating (in the author's experiments) is 32 cents. That is, a loss of 14 cents per pound is sustained in 12 hours, or a little over a cent per pound per hour. The *average* loss per day of 8 hours would therefore amount to about  $4\frac{1}{2}$  cents per pound. This does not look bad, but let us carry the proposition to its conclusion. Suppose the amount of glue kept heated at all times is approximately 100 gallons. That will represent perhaps 400 pounds of dry glue, and during the day the loss will become therefore,  $4\frac{1}{2} \times 400$  or \$18. In the course of a year this rises to the surprising amount of \$5,600. Surely the prevention of such a loss is well worth a little time and thought.

Glue does not deteriorate by standing for 12 to 24 hours in cold water (unless an already putrid glue is used, or the temperature of the water is allowed to rise to above 70°F.). And glue that is properly soaked may be brought into a condition ready for use very quickly by merely raising the temperature to 140°F. with stirring. There should be no difficulty experienced therefore, in keeping the amount of glue actually in solution down to just above the quantity which will be immediately used, and so entirely eliminate any loss from prolonged heating.

Of even more serious importance than the foregoing is the possible failure of the joint which is made from the weakened glue. As was previously stated, the loss in strength amounted to about 67 per cent of the original value. Assuming that the necessary strength was 2,500 pounds to the square inch, and that the glue was bought to carry 3,000 pounds to the square inch, thus giving a 500 pound margin of safety, any depreciation beyond this 500 pound margin would be disastrous. But, in the case cited, a 6 hour heating resulted in a 500 pound drop. The glue user has learned to buy upon a high margin of safety, and failures are not as common as might be expected, but when one does occur the user invariably concludes that he was sold an inferior glue, that the lot in question was not up to his previous buys—that the glue manufacturer had "put one over" on him. Would it not be well for him to look rather to his glue room?

May we not also properly ask why it should be necessary for the user to allow such a wide margin in strength for safety? The

fact that he does is in itself an admission that his use of it is uncertain; that he does not at all times get his full value out of the material. Just as soon as he has learned to control his *modus operandi* to the end that he shall get the full value from his glue, just so soon may he in confidence and with safety cut down his strength margin to a narrower limit, and buy a less expensive glue, or apply his original glue at a greater dilution—a procedure which will again save him many dollars on his glue bill in a year. The only reason, in fact, why glue failures under the conditions described are not many instead of few is that as the heating is in progress, so at the same time is evaporation taking place, and instead of an original 55 gallons there will be left after several hours of heating only, perhaps, 45 gallons.

If the evaporation of water from the glue which takes place on heating were made up by occasional additions of water it would very soon become apparent that the glue rapidly became thinner as heating progressed until it was altogether too watery to apply. In general this decrease in viscosity or spreading capacity escapes attention and remains quite unobserved because of the fact that the same heat treatment which is responsible for it also results in evaporation of the water and consequent concentration of the glue in the solution.

One other point in this connection is worth attention. The loss due to heating has been found to be proportional to the temperature, increasing rapidly as the temperature rises from 60°C. to the boiling point. The figures which have been given are based upon a heating at 80°. But very often, where the temperature is uncontrolled, much higher values are reached, and not infrequently in fact the glue is actually permitted to boil. A very few hours of boiling is sufficient to render the glue worse than useless for high class joint or panel work.

It is obvious, therefore, that prolonged heating of a glue results both in a loss in strength and a decrease in the covering capacity. The latter, however, is concealed through evaporation of the water; and the loss in strength is usually unobserved on account of the excess in strength of the glue as bought above that necessary in the operation.

The higher the temperature the more rapidly will depreciation take place.

The losses referred to may not be made good by the addition of water to make up that lost by evaporation, for the product



would be too thin to spread properly, and would result in a weaker joint. All losses due to overheating may, however, be minimized by dissolving only that amount which will be used immediately, and preventing the temperature from rising above 60°C.

As soon as these simple principles are efficiently applied, a lower margin of safety may be confidently employed, which means that a less expensive glue, or the same glue at a greater dilution, may be employed with equally uniform and satisfactory results.

**The Bacterial Decomposition of Glue.**—The unsanitary appearance of the glue room with its disagreeable stretches is proverbial. It has been taken as a matter of course for so long that it is too often believed a necessary adjunct to the use of that substance. Glue pots in some places are never cleaned. The floor becomes covered with a gradually thickening layer of the spillings. But glue is an animal product and subject to bacterial decomposition. What wonder, then that the pots, the room, the new work, all imbibe the characteristic putrid odor! Probably the greatest number of complaints which are made by glue consumers to the dealers and manufacturers are based upon the affirmation that the glue in question is "sour." Investigations show the pots and kettles to be coated sometimes inches thick with glue in an active state of decomposition that has been accumulating for months. It is doubtful if these same men would expect that sweet milk could be poured into cans containing decomposed milk without itself becoming sour very quickly, but they appear not to have applied that reasoning to the glue pot.

Putrefaction of glue takes place very rapidly at the temperatures which obtain in the glue room. A sweet glue allowed to remain for a few hours in contact with decomposing glue will become sour, but that indeed is not the worst or only objection to permitting of such practices. A sour glue is not merely a glue that does not smell good, but it is a glue that has suffered a chemical change in its constitution. That change is an hydrolysis, slightly different, in the nature of the cleavage products produced, from hydrolysis by water, acids, alkalies, or enzymes, but nevertheless an hydrolysis, or a breaking down of the gelatin molecule. This decomposition results in an alteration in the properties of the material. The viscosity, the jelly consistency, the joint strength obtainable, are all greatly reduced. Furthermore, the action of the bacteria does not stop upon the applica-

tion of the glue to the joint, but continues even after drying out. This means that a failure of the joint is very apt to result sooner or later. It makes no difference whether a high grade or a low grade product is used at the start, the contamination with the decomposing material will in a few hours reduce it to a low grade, and reduction in strength will continue in the joint.

The loss in dollars resulting from such practice is unquestionably enormous, not to mention the harm done to the house by an injured reputation due to failures in their glue work. Just as in the case of prolonged heating, a high grade glue may be bought, but by the time it is actually put into service it may have been reduced to a very low grade. But while the heating loss ceases as soon as the glue is applied, this is not the case with the decomposed glue, and the latter may, therefore, be productive of even more serious loss than the overheated material. This fact is certainly indicated, if not proved, by the experiments of the United States Forest Service previously referred to.<sup>1</sup> They found that the loss in strength and viscosity sustained by maintaining glues at 40°C. for a number of hours was actually greater than that sustained by maintaining them at 60° for the same period. At the latter temperature the bacteria are inhibited, if not killed, so that the loss in strength observed is due entirely to ordinary water hydrolysis. But at 40° the bacteria are very nearly at their optimum temperature for activity. The water hydrolysis is unquestionably greater at the higher temperature, so the greater loss in strength and viscosity at 40° is due directly to the decomposing action of the bacteria, and to nothing else.

The cure for this disastrous activity of bacteria is very simply to keep the glue pots, kettles, brushes, and all other articles that come in contact with the liquid glue, thoroughly clean. There is no remedy that may be applied to a decomposed glue to again bring it into a sweet condition, and all glue that has become sour should be discarded at once, and without regret. Attempting to use it up will bring even greater loss than the price of the glue thrown out. The glue pots and kettles should be drained into a clean container each night, and should be thoroughly cleaned before being used the next day. The brushes, stirrers, thermometers, hydrometers, and other equipment should likewise be well cleaned. The work benches and floors should be scraped free of all glue that has accumulated on them during the day.

<sup>1</sup> See page 512.

By following these simple precautions bacteria will be unable to gain sufficient headway at any time to damage the glue, while the general appearance and odor of the glue room, and the health and morale of the workmen will make such an alteration in glue room technique a decidedly worth while undertaking.

One further point in this connection. Glue is exceedingly sensitive to the moisture conditions in which it is stored. Occasionally glue will be stored in damp cellars where a considerable absorption of water will take place in the glue. Under such conditions it may happen that a sufficient amount of water may be taken up to enable bacteria, molds, or other microorganisms to attack the material. Molds especially grow under such conditions, and good glue may be completely spoiled by the decomposition effected by them. On melting these glues the viscosity will be low, the odor will be strong and sour, and joints made by their use will be weak. An excessively dry atmosphere is not to be recommended as the glues become brittle but it is to be preferred to damp conditions of storage.

## 2. GLUE AS AN ADHESIVE

Probably the oldest and most important service for which glue is employed is as an adhesive for joining together two pieces of wood. Cabinet making is an ancient craft and still consumes large amounts of glue, and the veneer industry is one of the largest consumers of glue. Panel work is coming to be regarded as a highly specialized art, and while some years ago it was looked upon as an "imitation" process, with the slur which usually accompanies the use of that term, it has now grown into favor for its own worth and artistic and strength advantages, and the craft is even contemplating a much greater substitution of built-up and panel work for the solid than has yet been undertaken. The advantages of such procedure in the producing of artistic effects, the conservation of the more valuable timber, and the production of greater strength together with less weight are undisputable.

**The Conditions Affecting the Adhesive Strength of Glue.**—For all glues that are to be used for joining, panel, or other adhesive purposes, the ultimate criterion for value must, of course, be the actual adhesive strength developed and maintained in service. It would seem at a glance that the importance of this



property would be so fundamental that it must inevitably constitute the principal test upon which selection would depend.

This would undoubtedly be the case were it not for the technical difficulties encountered in the making of the test. The importance of the adhesive strength has indeed always been recognized, and relative approximations of this property are constantly being made. A glue foreman will be asked to select between several glues submitted to him, and among other tests he will usually glue up a few joints of the several samples, clamp them up in the usual manner, and after standing a few hours, or a day, break them with a hammer or a chisel, and note which appears to be the strongest joint. But attempts at measuring the joint strength have not been confined to the unscientific treatment of the glue foreman. Many times the trained chemist has bent his energies upon the problem, but his efforts have been awarded with only a questionable degree of success. He has, however, succeeded in demonstrating that the strength attained in any joint is dependent upon many factors. These factors have been studied, one at a time, and the effect produced upon the joint strength by varying any of them is now quite generally understood. But only by taking the utmost precaution to eliminate every variable can truly comparative data upon strength be obtained.

Among the factors which have been found to influence the strength obtainable in a glued joint, made with any given glue, are the following:

- The concentration of the glue solution.
- The time occupied and temperature employed in heating the glue.
- The temperature of the glue when applied.
- The species, density, porosity, and moisture content of the wood used.
- The trueness of the joint.
- The amount and method of application of the glue in the joint.
- The temperature of the wood when glue is applied.
- The rapidity of handling.
- The pressure applied to the joint, and its uniformity of distribution.
- The time under pressure, and time of curing.
- The temperature and humidity during curing.
- The method of breaking the joint.
- The hydrogen-ion concentration of the solution.

From a survey of the above list of factors which may influence the joint strength of any given glue, it becomes more easily understood why the strength test has not met with greater



success. A perfect control of each of the above mentioned variables is an exceedingly difficult, if not quite impossible, task. A brief account of the particular influence of each of these factors is given below.

*The Concentration of the Glue Solution.*—It is self-evident that any wide variation in the concentration of the glue solution used, either above or below a definite optimum, would reveal itself by the production of weaker joints. This is, of course, recognized in a general way, but it is noteworthy that no precise determinations have ever been made, to the author's knowledge, of the exact relationships involved, or of the exact specification of the optimum value. In a general way it is recognized that the optimum concentration is very largely dependent upon the viscosity of the glue under consideration; that the higher the viscosity the lower may be the concentration required to produce the best results. But whether the viscosity is the only factor which defines the optimum concentration, and exactly what this concentration is for any given glue viscosity, has not been definitely established. It is common practice to use the lower grades of glues in concentrations of from 35 to 50 per cent, and the higher grades at from 25 to 35 per cent. Kahrs<sup>1</sup> worked out an elaborate scheme by which the most advantageous concentration could be read off on a chart, if the viscosity (by Kahrs' glue tester) was known. This was based on the principle that the viscosity was the only factor which affected the most desirable concentration. The chart merely indicated the amount of water necessary to be added to a given amount of glue of any viscosity in order to produce a batch of the specified optimum viscosity.

The author is of the opinion that such a method, although it possesses some distinct advantages, would not be equally applicable to all glues or to all woods. A fictitious viscosity is sometimes produced, which might alter the optimum value. But of more importance, a viscosity that would give the best results upon maple or other hard dense wood would certainly not be so desirable upon basswood, or any other porous type. Glue joins by penetrating the pores of the wood, resulting in a multiplying of fine interlacing threads of the material extending from one to the other of the two sections of the joint. A degree of viscosity must be selected such that a fair amount of penetration may result. If the glue is too dilute it will penetrate without any

<sup>1</sup> F. KAHR'S, *Glue*, No. 4, p. 9; No. 8, p. 4; No. 10, p. 10.

question, but the individual fibrils of glue, when dried, will be too thin to impart the greatest strength. On increasing the viscosity the penetration will diminish, but the individual fibers of dried glue will be thicker and stronger, resulting in a stronger joint. If the viscosity is further increased, the penetration will have diminished until the strength obtainable again becomes small. It is on this account that glue is not a good adhesive for metal or nonporous substances. The finer the pores in a wood, the thinner also must be the glue solution in order that a fair degree of penetration may take place. Thus dense woods require a rather thin glue. More porous woods do not require such thin solutions, and if such are used the liquid will sink deep into the wood, resulting in very fine fibers of the dried glue. Consequently more viscous solutions are required for the more porous woods.

The optimum viscosity will depend also upon the use to which the glue is put. Veneer work does not require as viscous solutions as joint work. The glue must be sufficiently mobile to be easily squeezed out during the pressing, or imperfections in the smoothness of the veneer surface will result.

*The Time Occupied and Temperature Employed in Heating the Glue.*—One of the very common practices which results in a great lessening in the joint strength is the tendency to melt up large batches of glue, and keep in this condition at a relatively high temperature for many hours before being completely used. Oftentimes a large amount of the glue which was melted early in the morning is still unused at night, and goes into the next day's allotment. Such a practice results, as detailed on page 511, in a decided weakening of the glue strength. If evaporation is prevented, either by the use of closed glue pots, or by the addition of water to compensate for that evaporated, then the joint strength may drop as much as 50 per cent in a day's heating.

The temperature to which the glue is heated and maintained is of equal importance. A very few hours of boiling is sufficient to make a glue practically worthless as an adhesive. It is unnecessary ever to heat the glue above 60°C., and any higher temperature will result in an unnecessary weakening in the strength of the glue.

*The Temperature of the Glue when Applied.*—If the glue is at too low a temperature when applied to the joint it will be unnecessarily viscous, and will set too quickly. It should be sufficiently

warm so that it will readily penetrate the pores of the wood, and so that it will not set before the joiner is able to finish his manipulation, and apply the pressure upon it. On the other hand, if the temperature is higher than necessary, the viscosity may have become too low; and a loss in strength will also be sustained on account of the excessive temperature, as set forth in the previous paragraph.

*The Species, Density, Porosity, and Moisture Content of the Wood Used.*—If a given glue at a given concentration and temperature is applied to different types of wood, the strength of the joint may be expected to vary according to the particular suitability of the viscosity used to the porosity of the woods. The wood of that porosity which is most suitable for the viscosity used will show the greatest strength. Density is more or less a measure of porosity. That is, the greater the density, the less the porosity. If the moisture content is high as a result of incomplete curing, then the pores, since they already contain water, will be incapable of absorbing very much glue, and the strength must accordingly suffer.

*The Trueness of the Joint.*—The strength of a glued joint must be proportional to the area of the effective surface of the joint. If, in a joint of 4 square inches only 3 square inches are in intimate contact, it must follow that the strength obtained will be much less than if the whole joint is in contact. Very little strength is developed by using glue as a mortar is used. The joined surfaces must be perfectly true to obtain the maximum strength. Sand-paper should not be used to remove the last imperfections in the surface, for the powdered wood which is scraped off fills up the pores of the wood, and retards the penetration of the glue. A good plane should be the final tool employed. Under no circumstances, however, should tests be made upon joints which are not perfectly true.

*The Amount and Method of Application of the Glue in the Joint.*—One often hears warnings against the "starving" of joints by using too little glue upon them. Of course, it is possible to use too little glue and so obtain a weak joint, but if the material is applied with a brush, or even a roller that is properly supplied, the danger of applying too little glue is almost negligible. The tendency among the consumers of glue is rather to use far more than is needed, and squeeze out the excess. The waste in this procedure is often very great.



But little is ever heard regarding the other opposite possibility—that of “overfeeding” the joint. If a large amount of glue is applied, and the excess is not squeezed or rubbed out, the danger of “overfeeding” may be a very real one. As the glue dries out in the joint it contracts, forming a honeycomb appearing structure, and joints of exceeding weakness may result. Whenever a broken joint reveals this uneven, honeycomb-appearance, it is sufficient proof that either there was too much glue allowed to remain between the two pieces of wood, or that the joint was not true, resulting in the same effect. The common practice of rubbing the joints together after applying the glue is beneficial only in that it works out of the joint the excess of glue or air. It may safely be said that the dangers of “starving” a joint are mostly illusionary, but the dangers of “overfeeding” it are always imminent. If the amount applied is adequate, it is virtually impossible to rub or squeeze out so much that the joint is weakened thereby.

*The Temperature of the Wood When Glue is Applied.*—When a warm glue solution is applied to a cold piece of wood, the layer of glue immediately adjacent to the wood will be chilled to the setting point before it can properly penetrate the pores of the joint. This must result in a joint considerably weaker than the maximum obtainable. The wood should be warm, but not hot. Excessive heating will expel more water than is desirable, and tend to warp the wood, making a true joint difficult to obtain. For this same reason the temperature of the glue room should be as high as is consistent with the comfort of the workmen, and a brief warming of the wood just prior to the joining will be sufficient.

*The Rapidity of Handling.*—A condition is observable in some plants where, on account of ignorance or indifference of the results incurred, an unnecessary lapse of time is allowed between the application of the glue and the placing of the joint under pressure. In such cases the glue has chilled and set to a jelly before the pressure is applied. In order to understand the detrimental effect of such a practice it must be emphasized that the influence of pressure is only to squeeze out the excess of glue, and to minimize the inequalities in the perfection of the joint. By permitting the glue to gel before applying the pressure is to rob the pressure of its usual effect. A jelly will not readily be squeezed out. The result is a joint which contains an excess of



glue between the two sections, and, as shown in a previous paragraph, this very materially weakens the joint. The pressure should always be applied as quickly as is consistent with good workmanship after the spreading of the glue.

*The Pressure Applied to the Joint, and its Uniformity of Distribution.*—So far as the author is aware, the only carefully conducted tests that have been reported upon the relation of the joining pressure to the strength of the joint are those described by Gill<sup>1</sup> in 1915, and the investigations of the author<sup>2</sup> in 1920.

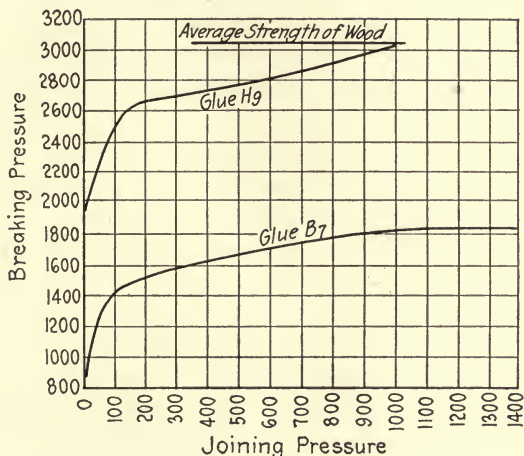

FIG. 102.—The effect of joining pressure upon strength.

Gill employed a joining pressure varying between 10 and 100 pounds to the square inch, and reported that “a pressure of 30 pounds to the square inch gave a joint about 15 per cent stronger than either the 10 or 100 pound pressure.” The data obtained for the tests at the different pressures are not given, but the variation between the maximum and minimum values obtained is very great—averaging in the neighborhood of 200 per cent. This being the case it seems difficult to regard the 15 per cent variation reported for different pressures as significant.

Experiments which have been conducted in the author’s laboratory have shown that high pressures are not only harmless, but are decidedly beneficial from the standpoint of the ultimate strength developed. Joining pressures varying from 10 to 1,400

<sup>1</sup> A. H. GILL, *J. Ind. Eng. Chem.*, **7** (1915), 102.

<sup>2</sup> R. H. BOGUE, *Chem. Met. Eng.*, **23** (1920), 200.

pounds to the square inch were used. These pressures were obtained by placing the joints, very carefully prepared in accordance with the outline on page 530, between the parallel plates of an Olsen Universal Testing Machine. A ball-bearing was used both above and below the steel plates to insure a perfectly uniform distribution of the pressure. Previous tests made by using clamps had shown the impossibility of obtaining either a constant, or a uniformly distributed, pressure by that means.

The data show the strength of the joint to rise rapidly with increasing joining pressure between 10 and 200 pounds to the square inch. Above the latter pressure the strength continued to increase slightly to 1,000 pounds, and thereafter remained constant to 1,400 pounds. This is illustrated by the curves in Fig. 102.

In the light of the frequent assertions made that "too much pressure must not be used in gluing surfaced wood, as the glue may be pressed out too completely from the joint, producing a so-called starved joint,"<sup>1</sup> a consideration of the meaning of these data may not be out of place. The author has repeatedly emphasized that a glue is not a cement. Let us exaggerate the conditions for a moment in order to fix our point. Suppose that it is possible to make a joint of two pieces of wood, and that a large enough excess of glue is added to produce a layer of jelly an eighth of an inch thick between the two pieces. This jelly, we all know, is two-thirds or more water. On setting, therefore, the water is evaporated off, leaving the one-third or less of solid glue material. The evaporation of the water sets up strains and stresses in the material. The jelly contracts, draws away from the surface, and becomes contorted. Such stresses may even produce cracks in the dried glue, and a certain degree of porosity may be observed. Obviously a joint so made would show great weakness. This is an absurd case. No glue man would think of making such a joint. But assume that the jelly layer is reduced to a fiftieth; or a hundredth of an inch. Then we have conditions that are common. But the effects outlined above would still be present, and in exact proportion to the thickness of that layer. As the layer of glue between the wood pieces is made vanishingly small, the strength of the joint will approach its maximum value. The bond between the two pieces of wood should consist only of the vertical and interlaced

<sup>1</sup> National Advisory Committee for Aeronautics, *Report 66* (1920), 9.

threads of glue passing from the pores in one piece to the pores of the other.

If this is the case, and we seem justified in making that conclusion, then it must follow that, provided the glue is properly applied, and in a condition such that a fair degree of penetration results, there can be no such an effect as a "starving" of a joint, and no such thing as too much pressure, as far as the glue is concerned. The advantageous results realized by high pressures can be explained only upon the assumption that such pressures are necessary to squeeze out the maximum amount of excess glue in the joint, and to minimize any slight inequalities in the perfection of the joint.

It should be stated that the crushing strength of the wood used sets a very definite limit to the pressure which may be applied with safety in any case. The porous types of wood will be injured by pressures which have no effect upon the denser varieties. And a thick piece of wood will stand without injury much higher pressures than could be used in thin cut veneers.

*The Time under Pressure and Time of Curing.*—If the pressure is removed from the joint before the glue has been given a sufficient time to harden, the two pieces will separate slightly, resulting in a weakened joint, and if the joint is broken before the glue has thoroughly dried out, the strength will be that of the partially solidified jelly, rather than of the completely cured glue. The author finds that the pressure should be maintained for about 10 to 12 hours, and the curing for about seven days, in order to obtain the maximum strength.

*The Temperature and Humidity During Curing.*—The rapidity and thoroughness of drying out depend in large measure upon the temperature and humidity of the curing room. A low temperature and a high humidity make it almost impossible to obtain a perfectly cured joint. The glue, under these conditions, remains in the form of a partially dried jelly, but does not completely dry out. The opposite conditions of a warm temperature and low humidity are most favorable, both to the rapidity and thoroughness of the curing.

Some glue consumers are in the habit of heating the joint, after it has been completed, to a rather high temperature for several hours. This practice has no advantages, as it keeps the glue in the liquid condition for a long period, and the resulting

hydrolysis results in a much weakened product. Gill<sup>1</sup> has shown that a heating of the glued blocks to 65°C. for several hours diminished the strength very materially. This is fully corroborated by the author's experience.

*The Method of Breaking the Joint.*—The results of the so-called strength test are usually reported in pounds per square inch, but it must be urged that the method by which the break is made is of the greatest importance. As will be shown in the following pages, the joints are made and broken in several ways. The joint may be end to end or side to side, and it may be broken by pulling apart, by shearing apart, or by applying the load at the joint while the two ends are supported. The results obtainable vary widely. Very few results by different methods are rightly comparable, but the author has found the observed "strength" per square inch to be about 500 to 600 per cent higher when blocks of 4 square inch glued area were sheared apart by pressure, than when strips of 1 square inch glued area were sheared apart by pulling. A standard procedure should be adopted, and the method of the Forest Products Laboratory<sup>2</sup> at Madison, Wisconsin, appears to possess the greatest advantages of any that have been proposed.

*The Hydrogen-ion Concentration of the Solution.*—In Chap. V it was pointed out that the viscosity, jelly consistency, swelling, and practically all properties of a gelatin varied according to the hydrogen-ion concentration, or pH, of the solution. A number of tests have also shown that the adhesive strength of a glue varies in a similar way, the maximum being attained at pH values in the neighborhood of 3.5 and 7.5, while beyond these limits the strength drops rapidly. A slight diminution in strength is also found to follow the bringing of the solution to the isoelectric point—pH 4.7. Sherrick<sup>3</sup> has observed the same tendency in the adhesive qualities of glues prepared for hectographic plates.

**Methods of Making the Adhesive Strength Test.**—On account of the many factors which enter into any test upon strength, on account of the skillful technique necessary in order to obtain reliable and comparable data, and on account of the rather elaborate equipment required for properly making the

<sup>1</sup> A. H. GILL, *loc. cit.*

<sup>2</sup> See page 530.

<sup>3</sup> SHERRICK, personal communication.



test, the strength test has not received the universal attention in glue evaluation that might have been expected. In lieu of the actual strength test many other tests upon certain properties, as jelly consistency, viscosity, and melting point, and analysis for certain chemical groups, as  $\alpha$  gelatin,  $\beta$  gelatin, etc., have been proposed as being true indications of the real strength value. One or another of these propositions have been quite generally accepted by the glue trade, and as a result very few consumers include an actual strength determination in their specifications. One of the exceptions to this has been the specifications of the National Advisory Committee for Aeronautics, for glue to be used on airplanes, but the tests were made by the Service at the Forest Products Laboratory.

The methods that have been proposed for making the strength test are described briefly below.

*Kahrs' Method.*—Kahrs<sup>1</sup> used blocks of well-seasoned oak, glued end to end, the area of the joint being either 1 square inch, or 1.44 square inches (one hundredth part of 1 square foot). The length of the former type of block was  $4\frac{1}{2}$  inches, and a shoulder was left at the end away from the joint to impart greater strength. The blocks were glued together after a careful weighing and measuring and varnishing, placed between clamps, and later broken apart. For this purpose holes were bored near the ends of the blocks, steel pins inserted, and by means of an improvised machine, pulled apart. The machine used was of a lever type, the placing of weights at various points on the lever arm exerting a measured pull at the joint. The blocks and machine are illustrated in Fig. 103.

*Gill's Method.*—Gill<sup>2</sup> first made briquettes of fuller's earth, diatomaceous earth, quartz sand, and sawdust, using glue as a binder. These were dried at 80°C. for 6 days, and broken by the well-known cement briquette testing machine. Difficulty was experienced in drying completely, the briquettes were full of blow-holes, and no consistent results could be obtained.

Gill then used rectangular prismatic maple blocks, sawed into a special form as shown in Fig. 104, and having an end area of 1 square inch. The blocks were glued end to end, and a uniform pressure secured by placing in a frame wherein the pressure employed was determined by placing weights on a lever arm bear-

<sup>1</sup> F. KAHR'S, *Glue* (1910), No. 3, p. 4; No. 4, p. 5; No. 5, p. 8; No. 6, p. 10.

<sup>2</sup> A. H. GILL, *loc. cit.*

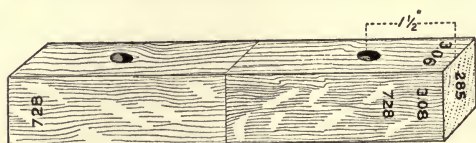
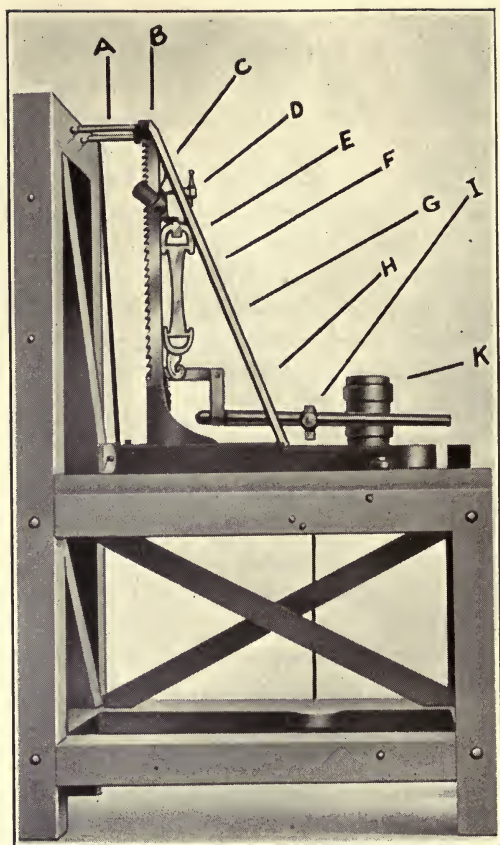

FIG. 103.—The breaking machine and test pieces used by Kahrs.

ing upon the joint. The pressure was maintained for 3 hours, and the joints allowed to dry at room temperature for 2 to 4 days. They were then pulled apart in the cement testing machine, after the ends had been blocked up with bronze blocks to fit the briquette holder of the machine.

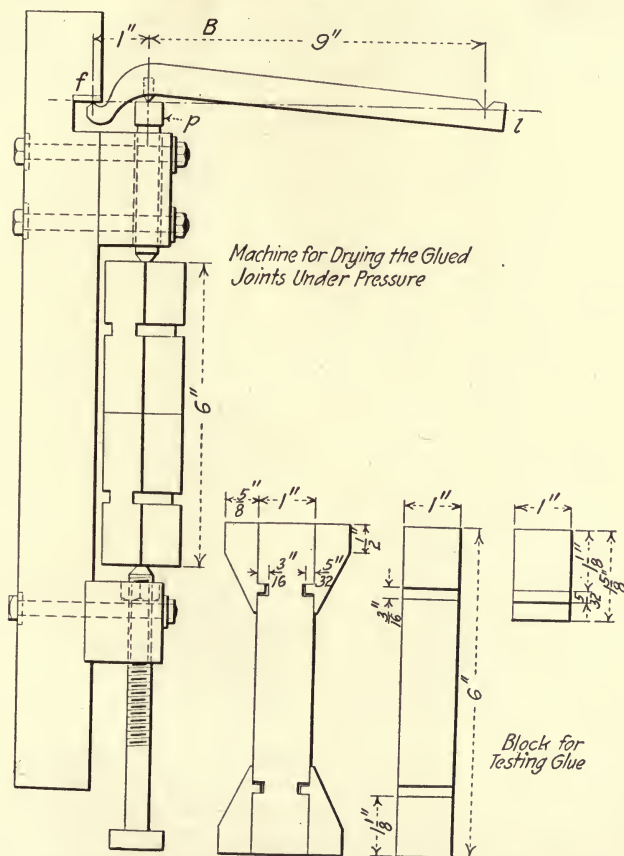

FIG. 104.—Blocks and apparatus used in Gill's strength test.

*Rudeloff's Method.*—Rudeloff<sup>1</sup> applied the glue solution to the planed end surfaces of two pieces of red beech wood, 185 mm. long, 125 mm. broad, and 50 mm. thick, and placed the blocks so that the glued surfaces crossed at right angles. A definite joining pressure was used, and the force required to tear the pieces

<sup>1</sup> M. RUDELOFF, *Mitt. kgl. Materialprüfungsamt.*, **36** (1918), 2; **37** (1919), 33. Cf. *Chem. Abstracts*, **13** (1919), 1164; **14** (1920), 2429.

of wood apart measured by means of a suitable machine. He later used both edge and flat grain joints of beech, ash, oak, and fir, using 50, 40,  $33\frac{1}{3}$ , and 25 per cent glue solutions at a joining pressure of about 5 kg. per square centimeter (about 65 pounds per square inch). Individual tests varied as widely as from 63 to 102 kg. per square centimeter.

*Forest Products Laboratory Method.*—The method developed by the Forest Products Laboratory<sup>1</sup> at Madison, Wisconsin, is as

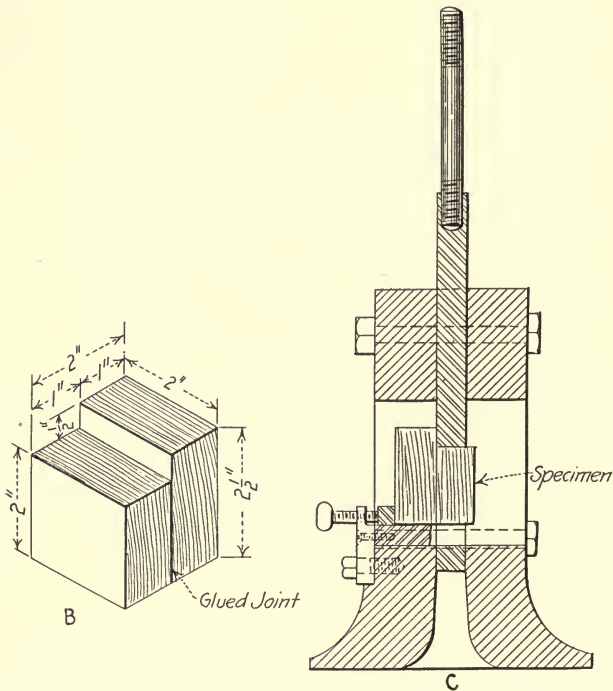

FIG. 105.—The shear block test specimen and shearing tool used by The Forest Products Laboratory.

follows: Two blocks of hard maple about 1 by  $2\frac{1}{2}$  by 12 inches in size are glued together, subjected to a definite pressure, allowed to dry out for a week, and cut into blocks as shown in Fig. 105. The glued area of each block is exactly 4 square inches. One of the two pieces is permitted to extend a half inch beyond the other to facilitate the technique and prevent a slip in the shearing process. The blocks are broken by placing in a shearing

<sup>1</sup> National Advisory Committee of Aeronautics, *Report 66* (1920), 21



tool, as shown in the figure, in which pressure is applied upon the end of the smaller block until the joint separates. This pressure is most conveniently obtained by the use of a Universal Testing Machine,<sup>1</sup> by which the exact pressure at the breaking point may be read directly.

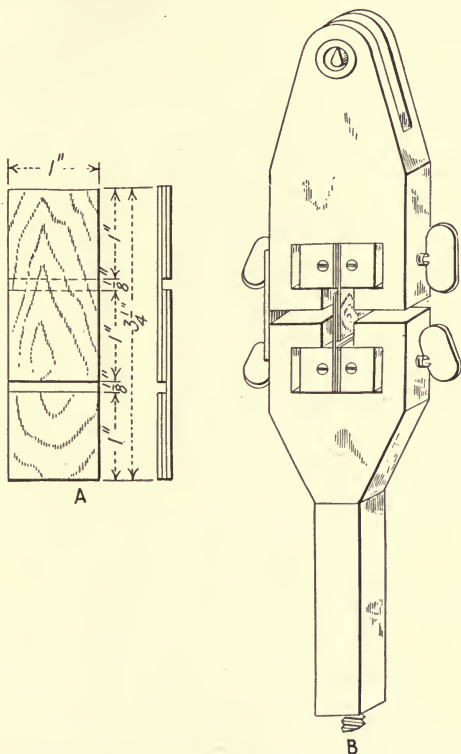

FIG. 106.—The plywood test specimen and plywood shearing tool used by The Forest Products Laboratory.

If the break occurs entirely in the glue, a measure of the strength of the glued joint is obtained, but if, as frequently happens, the break takes place partly or wholly in the wood, the breaking pressure is less than the strength of the glue, and in order to obtain more exact data the test must be repeated with a stronger wood. The shearing strength of hard maple, using similar blocks, is about 3,200 pounds per square inch, so the exact

<sup>1</sup> The shearing tool and testing machine may be obtained from the Riehle Brothers Testing Machine Co., 1424 N. 9th St., Philadelphia, or The Olsen Testing Machine Co.; 500 N. 12th St., Philadelphia, Pa.

strength of glue which is stronger than this cannot be measured upon maple. The results obtained by this method are reasonably satisfactory, and by taking the average of several breaks the test becomes entirely practicable.

An additional strength test is made upon glues that are intended for plywood manufacture. The form is the one adopted by the British and American Governments for the testing of aircraft plywood. It is shown in Fig. 106. A piece of the plywood  $3\frac{1}{4}$  inches long by 1 inch wide is sawed so that the inner section is cut through from opposite sides leaving a section of 1 square inch. This is then placed in a machine, as shown, designed for testing cement, but provided with special grips. The section is subjected to tension and fails principally from shearing.

*Welmers' Method.*—As an illustration of the way in which the strength test may be employed by any glue shop foreman, and as an example of the more "advanced" of the modern glue shop methods, may be cited the suggestion of Welmers.<sup>1</sup> He glues two pieces of wood together, measuring 1 by 8 inches, edge to edge, so that a right angle is formed. One of the arms of this angle is fastened vertically into a rack on the wall, while a beam is secured to the horizontal arm as shown in Fig. 107. At the

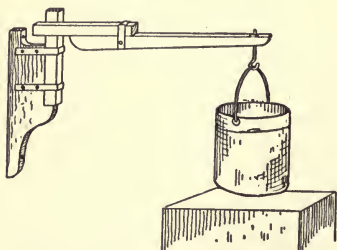

FIG. 107.—Welmers' adhesive test.

end of the beam is hung a pail into which water is allowed to run evenly and slowly. The weight of the pail with its contents at the breaking point of the joint is the measure of the glue strength. Such tests as this are, of course, crude, but if made with proper care some indication of the relative strength

should be obtained. It is at least a beginning, and if glue consumers realized the advantages of such tests, it would not be long before a more standard and a more accurate procedure would be generally adopted.

*Heinemann's Method.*—A different type of adhesive test has been used by Heinemann.<sup>2</sup> He suggests that a determination of the minimum strength of a glue solution that exhibits a definite

<sup>1</sup> J. WELMERS, *Veneers*, **14** (1920), No. 11, 35.

<sup>2</sup> A. HEINEMANN, *Chem. Ztg.*, **24** (1900), 871.

adhesive power on paper be taken as the measure of glue strength. Strips of strong smooth paper were used; one brushed over with, say, a 1 per cent solution, another strip of paper laid over the first, and pressed under a 5 pound weight for 1 or 2 minutes. The paper is then taken up, and it is observed if the joint will support a weight. Heinemann found that at or about the critical degree of dilution the joint will either support a fairly heavy weight—even as much as 30 pounds—or scarcely no weight at all. All measurements are referred to a standard for evaluation.

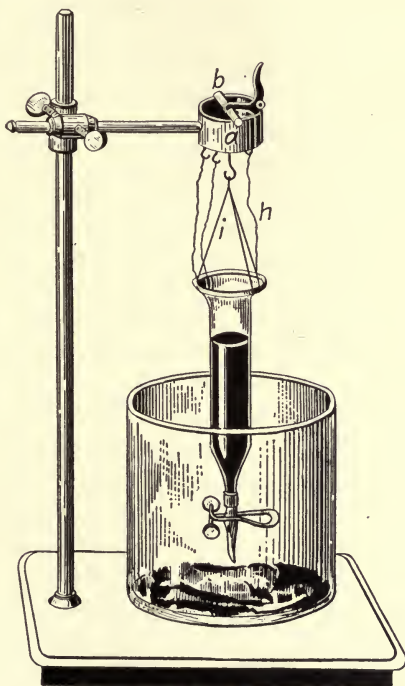

FIG. 108.—Weidenbusch's strength test.

*Other Methods.*—Setterberg<sup>1</sup> soaked strips of unsized paper in a solution of glue of definite concentration, pressed the strips between blotting papers to remove the excess of glue, and when dry broke them in a paper testing machine by tearing tests.

Weidenbusch<sup>2</sup> prepared exactly equal prismatic rods of gypsum 9.2 cm. long with the sides of the transverse section 4 mm.,

<sup>1</sup> SETTERBERG, Cf. POST, *Chem. tech. Rep.* (1911), ii., 857.

<sup>2</sup> WEIDENBUSCH, Cf. LUNGE and KEANE, *ibid.* (1911), ii., 456.

and having a weight of 1.7 grams. These are dipped in a glue solution for 5 minutes, then removed and allowed to dry. The rod is then placed across an iron ring as shown in Fig. 108, and a dish hung to the center of the rod into which weights are placed until the rod breaks. Weidenbusch claims to have obtained fairly consistent results by this means, but Gill<sup>1</sup> has found such methods unsatisfactory.

Hauseman<sup>2</sup> first employed blocks of "biscuit-ware" stone which he glued together and subsequently pulled apart. Not obtaining satisfactory results by this means he next used pieces of straight grained walnut  $9 \times 2 \times \frac{3}{8}$  inches in size. These strips were glued so that 4 square inches of surface were in contact, and after leaving in the clamps for 48 hours, and curing for a further 24 hour period, they were sheared apart.

**The Selection of Glues<sup>1</sup> for Joint and Panel Work.**— Although no set rules can be laid down for the selection of a glue for a given purpose, yet a few general considerations should be borne in mind. Too often a consumer of glue fails to recognize the wide differences that exist in the several grades on the market. What he really wants is the lowest priced glue that will do his work satisfactorily, but his lack of knowledge upon the subject leads him to believe oftentimes that price is the sole factor worth attention, and his work suffers accordingly.

On recognizing his own ignorance upon glue he may put his problems up to the glue salesman and rely upon him to provide the proper material. Although most large glue houses employ competent and honest salesmen to handle and distribute their product, yet it must be understood that not all glue salesmen are experts in glue engineering, nor are all salesmen scrupulously conscientious in giving the buyer the best for his money. In short, a consumer who relies entirely upon the salesman is placing himself in a position where he may be sold more expensive glue than he needs; an improper type of glue for the service desired; a poor glue for the price of a good material; or other glues fraudulently described. No injustice is meant to be done the many reputable and competent dealers and salesmen, but not all of these are honest, and not all that are honest are competent. The only safe recourse for the consumer to follow is to

<sup>1</sup> A. H. GILL, *J. Ind. Eng. Chem.*, **7** (1915), 102.

<sup>2</sup> P. A. HAUSEMAN, *ibid.*, **9** (1917), 359.



make or have made proper tests upon all material bought, and ascertain that the shipment is as per specifications.

The belief that the price should be the determining factor in glue purchases should be dispelled. A higher priced glue should, as has already been shown, have a much greater covering capacity than a cheaper product, and at the same time produce much stronger joints. These factors must be properly balanced if glues are to be selected efficiently. Under no circumstances should a partially decomposed glue, as revealed by the disagreeable putrid odor, be accepted.

For high class joint work only a good grade of hide glue is used. Although some of the best bone glues may give as good results as an intermediate or low grade of hide glue, it is rarely that large amounts are diverted to such usage. Glues that have been given a fictitious viscosity, as by the addition of alum, should be regarded with suspicion until they have been proven satisfactory. An extraordinarily high viscosity should be compared with the jelly test, and if the former is found to be incommensurate with the latter a test should be made for ash and alum. An unusually clear glue with high viscosity will often be found to have been clarified with alum. The use of glues with such abnormal viscosities is not ordinarily attended with the best results, for either the glue will be diluted to the consistency at which it is easily applied, and in that case contain actually too small an amount of real glue to make a strong joint, or else it will be applied at the usual percentage of dilution, and in that case be too thick to easily penetrate the pores of the wood, and fail from that reason. If, however, the high viscosity is accompanied by a similarly high jelly strength, then such a dilution that will bring the material to a good working condition will not result in a weakened joint.

An abnormally high jelly strength for the viscosity is also undesirable as a rule on account of the rapidity with which such a glue will set. If the glue sets before the joining operation is completed and the pressure applied, the joint will be weak. In using such glues it is necessary that the wood be heated to a higher temperature, or that more rapid operation be employed.

The hydrogen-ion concentration, or the degree of acidity or alkalinity, should be taken into consideration, as an excessively alkaline glue, pH 9.0 or higher, is usually indicative of overlimed stock which will continue to weaken even after applying to the

joint, and an excessively acid glue, pH 3.0 or less, may affect and weaken the fiber of the wood. Between these values, however, there are not likely to be any ill effects noted. The region of pH 4.7 should be avoided, as the viscosity, swelling, strength, etc., of the glue are least at this point, but this may easily be corrected by the consumer by the addition of small amounts of acid or alkali. The regions of pH 3.5 or 8.0 are ordinarily most favorable.

If the glue is to be applied by hand the foam need not be considered. If spread by machine, excessive foaming is undesirable. This is ordinarily depressed by the addition of a little fatty matter, but if too large amounts of grease are present a weakening of the joint will result.

For veneer work a lower grade of glue may be employed, but a higher viscosity is desirable. This latter is necessary on account of the tendency of a thin liquid to penetrate the pores of the thin sheet of wood and show itself on the opposite surface. The higher viscosity of the liquid used tends to offset this tendency, and may be secured either by using a higher concentration of the glue, or by employing a glue of a higher viscosity. Since an exceptionally high grade is not necessary, the desired results are very well obtained by using a rather high grade of bone glue and at a somewhat greater concentration. This gives the higher viscosity necessary without increasing the cost. Where penetration does not occur, or when it makes no difference if such does take place, a thinner liquid may be used.

**The Application of Glue as an Adhesive.**—In addition to the use of glue in the wood-joining trades, the adhesive properties of the material are made use of in a number of other industries.

The weakest grades of glues, either hide or bone, are usually suitable for the making of *paper boxes* and *cartons*. Only those glues that are in a state of decomposition may be regarded as unfit. Of course, a certain amount of adhesive strength is required, but since the strength necessary is only that of the paper or cardboard used in the box, it is rarely that an animal glue of the lowest grade will not be sufficiently strong. Because no great strength is required for this service, other substitutes for glue have to a great extent replaced the animal product for this class of work. Sodium silicate, or water glass, is greatly used, especially in corrugated fiber boards, and cheap starch

and dextrin glues, as well as the lower grades of liquid fish glues, are abundantly employed.

For *bookbinding* Zaensdorf<sup>1</sup> recommends that while pastes should be employed for morocco, calf, russia and vellum, all leather with an artificial grain should be glued, as a greater body is imparted to the leather by the glue and the grain is preserved. Cloth bindings are dipped in glue and turned in at once. For each special type of cover, as velvet, silk, etc., the procedure used is varied to suit the conditions. A rather high or medium grade of hide glue is usually employed for this work, and it should be clear in most cases. For fastening the sections of the book together at the back a less expensive glue may be employed, bone glue being generally used. It is applied with a brush, and in Germany is worked in with a special hammer and the excess taken off with a brush.

A very satisfactory *paste* for fastening paper, leather, etc., is made by dissolving 4 parts of good glue in 80 parts of water, and pouring this mixture into a solution of starch made by dissolving 30 parts of starch in 200 parts of cold water and warming.

A *leather-metal adhesive* is prepared by digesting a small amount of powdered nutgalls in 8 parts of water for 6 hours; then dissolving 1 part of glue in 8 parts of water. The leather is moistened with the nutgall preparation, and the glue applied to the metal which has just been roughened and heated. The leather is placed on the metal and dried under pressure. It is said the leather will split before the joint will give way.

*Waterproof glue* can be made by the addition of a solution of potassium bichromate or calcium chromate to a strong glue solution. The glue is then applied to whatever service is desired, and after gelling is exposed to the direct light of the sun. This results in a change in the composition of the mixture<sup>2</sup> by which the mass becomes insoluble and waterproof. Such a glue may be used for waterproofing fabrics, canvas, awnings, roofing papers, etc. It has been used as a cement for joining crockery and sealing cover slides. Its use in photography is described elsewhere.<sup>3</sup>

Tannin is also used in connection with glue in waterproofing

<sup>1</sup> ZAENS DORF, "Art of Bookbinding," 93.

<sup>2</sup> See page 573.

<sup>3</sup> See page 571.

fabrics. The goods usually are dipped alternately into a very dilute solution of glue and then into a moderately strong solution of tannin. After each dipping the fabric is pressed between rollers, and allowed to dry for some time, then the process repeated until the mesh of the goods is quite lost in the insoluble material surrounding them.

Glue rendered insoluble by the addition of formaldehyde may also be used for waterproofing, but the technical difficulties of handling the material have greatly limited such use.

*Rubber cements* are of various types, but very good ones are in use that are made of mixtures containing glue, admixed with glycerin, chloroform, and water. The chloroform renders the product permanent against decomposition. A mixture of glue with sulphur, barium sulphate, alum, collodion, and sulphuric, acetic, nitric, and formic acids has been patented as a "gelatinous resilient composition." The use of acids is objectionable, however, as the product will weaken due to hydrolysis, and if the cement is brought in contact with metal a corrosive action will take place.

*Frosted glass* is a form of glass that is much used in the doors and partitioning windows of offices where privacy is desired. It is made by allowing a glue or gelatin to rapidly dry out upon a plate of ordinary rather thick glass. As the glue loses its moisture it contracts, and the power of the gelatin is so great it tears away the surface of the glass itself, chipping it into characteristic fern-like patterns. The general appearance of the design can be modified by varying the properties of the glue used; *i.e.*, a brittle glue will give a different pattern than a tough glue, and the addition of salts also modifies the patterns. A strong gelatin solution containing 6 per cent of alum gives exceptionally fine designs.

### 3. GLUE AS A SIZING AGENT

**The Sizing of Paper.**—Glue is caused to serve for two distinct purposes in the manufacture of *wall paper*. It is employed as a binder for the clay, paris-white, or other material with which the papers are grounded, and also as a sizing agent for the ground colors, and in some cases for the top colors. The latter are, however, more commonly applied with a dextrin or starch mixture. Casein has at times been employed for the ground



size, but its normally high price and more difficult working properties have prevented any great substitution of this material for glue. Other attempts to find a suitable size for the paper industry have been made, but without notable success. Partially saponified rosin mixed with some forms of starch has been tried but the failure of these mixtures to give uniform results with different colors has retarded their adoption.

In the selection of glues that will be satisfactory for use upon wall papers the greatest diversity of possibilities which may make a given glue excellent or worthless for the purpose present themselves. In fact, for no other service for which glue is employed is the exact nature of the materials, both of the color bases and the glue itself, so necessary to take into careful consideration. The importance of doing so, and the type of result that would obtain from a failure to do this, is best shown by a consideration of the nature of the colors that are used on wall papers.

Soluble dyes cannot be employed directly as they would penetrate the pores of the paper and spread. Insoluble lakes would require incorporation with water before mixing with the glue solution, and mixing machinery would then be required to be installed at the plant. The most general practice, therefore, is to precipitate the color directly upon an insoluble base such as finely divided barium sulphate, draw off the precipitated mass after setting, wash to free it of excess of precipitant or reagent, and then separate from the excess of water by running through a filter press or a centrifugal hydro-extractor. This treatment leaves the color material as a heavy insoluble paste, sometimes spoken of as *pulp color*, and in this form is easily incorporated with the glue solution in the preparation of the sized material.

The precipitation of the color upon the insoluble base may be performed either by causing the precipitation of the base and the color simultaneously, or by precipitating the color upon the base suspended in the solution. The former are productive of the best results but are somewhat more expensive in preparation. The latter type may be made by suspending the base, as barium sulphate, in a water solution of one of the color reagents, as for example, potassium bichromate for the preparation of Lemon Yellow, and adding the precipitant, in this case lead acetate. A pulp color so produced is weak in coloring power and not so firmly fixed as the other type.

As an example of the simultaneously precipitated variety,

Bordeaux eosine is prepared by adding to an aqueous solution of eosine, first a solution of sodium carbonate, followed by one of barium chloride. The latter solution precipitates the color and at the same time reacts with the sodium carbonate to form insoluble barium carbonate. A solution of magnesium chloride is then added and this is followed by one of sodium hydroxide. These react to form insoluble magnesium hydroxide. The color is in this way much more intimately admixed with the precipitates than could be possible if the latter were suspended in the solution prior to the precipitation of the color.

In the preparation of some pulp colors a number of chemicals are employed in order that the exact shade of color desired may be produced. The viscosity of reagents employed, and the frequent failure to wash out completely the excess of precipitant or reagent, makes the proper selection of glue for service with them a matter of concern. And even the pulp colors produced as above described are frequently loaded down to an astonishing extent with further additions of heavy chemicals. Aluminum sulphate, lead acetate, barium chloride and other chemicals are regularly added. As an example may be cited a formula for Bremen Blue:

	POUNDS		POUNDS
Sodium carbonate.....	163	Barium sulphate.....	50
Aluminum sulphate.....	200	Malachite green.....	5
Barium chloride.....	350	Tannic acid.....	8

It is intended, of course, that there shall be no excess of any reagent left, after the washing, in a soluble condition in the mixture, but this desideratum is rarely attained in practice, especially as cheapness is one of the major requirements for these pulp colors when used upon the general run of wall paper. And any excess of any one of the above chemicals may be expected to affect the glue in one way or another. The aluminum sulphate and the tannic acid especially would seriously influence the properties of a glue, causing a streakiness or "livering" of the sized mass.

The presence of the large excess of sodium carbonate which is introduced into most pulp colors is usually more than sufficient to counteract any acidity that may be introduced through the glue. Except in unusual instances the acidity or alkalinity of a glue will not be excessive, but after mixing with the color base the

mixture will usually be slightly alkaline. It should be previously determined, in such cases, if this change in reaction of an acid glue produces any concomitant change in the properties that will be deleterious. If no such buffer is present the influence of slight changes in hydrogen ion concentration upon the colors should be observed, and the selection of glue made accordingly, or its reaction properly adjusted prior to use.

The presence of grease in small amounts is probably not deleterious to the satisfactory working of a glue in wall paper sizing. There is, however, a difference of opinion upon this point. Some houses employ greasy glues constantly, and even add more oil if the glue foams badly, while other houses regard the presence of even traces of grease as prohibitive. Its presence is considered by its advocates to brighten the colors and to produce a more uniform flow of the color material from the rollers of the printing machine, in addition to lessening the foam. It is argued, on the other hand, that grease will penetrate the paper producing grease spots, and the customary method of making the test, by painting strips of paper with the glue to which has been added a little dye, produces this effect. If, however, a pulp color such as is actually used in practice were mixed with the glue, rather than the straight dye, most of those glues which, by the former method, showed the presence of grease would, by the latter procedure, show no trace of it. The reason for this lies in the power of the mineral matter of the pulp color to absorb the fatty matter, or dissipate it until its effect is negatived. If present in large amounts, however, the grease may actually react with some constituent of the pulp color resulting in the production of insoluble metallic soaps which would interfere with the uniformity of the color on the paper.

A consideration of viscosity in the selection of glues for wall paper use is of importance on account of the mechanical spreading of the mixture. The sized colors are applied from a roller and if the flow is not rapid and uniform there will be difficulty. In general, therefore, the lower the viscosity the better will be the glue for this service. This property must not, however, be carried to the point where other necessary properties are lost. The actual binding strength need not be great, but it is important that the material have some strength. For the clay ground work a low grade of bone glue is usually satisfactory, but for the color size the lower grades of hide glue are preferred. It is very



desirable that the glues used with the colors be clear, as any cloudiness will result in a lessening in the brilliance of the dye.

In ordinary *sized paper* the glue is applied in one of two ways. The glue is either put into the beater with the paper pulp previous to making, or more frequently, as that process is very wasteful, the paper is run through a dilute bath of glue just before drying. In sized paper there is seldom anything used with the glue except at times a little alum to increase the body and give the paper a somewhat harder finish. *Coated paper* is made by applying a mixture of glue and various pigments or fillers about the consistency of cream to the paper after it has been finished. It is usually a separate operation and is performed on a separate machine. This coating, unless calendared afterwards, will give a matte finish. High gloss papers are usually coated papers.

The adaptability of a glue for sizing and coating is dependent upon exactly the same factors as obtain in the case of glues for wall papers. Low and medium grade hide glues are mostly employed, although high grade bone glues are sometimes used. Clearness is one of the most important properties which glues for this purpose should possess. If the glue is used as a size on white paper, the absence of any brownish color is imperative. Casein has largely replaced glue for this service on account of its whiteness, but glue is still used in considerable amounts. Water-proof coatings are sometimes applied by employing a glue solution to which has been added potassium bichromate solution. The coated paper is then exposed to the influence of sunlight which renders the paper practically water-proof.

**The Sizing of Textiles.**—Glue and gelatin find extensive use in the manufacture of wool, silk, and other fabrics, both as a size to be mixed with the dye, and as a finishing size for the whole. For service in textile manufacture the purity of the glue is of the utmost importance. The most objectionable impurity which must be avoided is sulphur dioxide or sulphites left in the glue from the bleaching process. And yet very clear glues only may be used as dull glues would dim the brilliance of the color.

The colors employed for dyeing fabrics are much more delicate than those used in paper, and are usually soluble. For this reason the presence of traces of mineral acids or alkalies must be ascertained and their exact effect on the colors to be employed noted. Wools dyed black or any other dark color are dyed with mixtures containing logwood (hæmatoxylin and hæmatin)



extracts containing glucose. These may be badly spotted if the glue used contains any notable proportion of mineral acids or sulphites.

This applies to an even greater degree with silks as even more delicate colors and mixtures of colors are used. For example a pale blue color is produced on silk by dyeing with a fast red in combination with a blue and a violet. Sulphur dioxide will react with the blue and the violet, discharging those colors, and leaving the red unaffected. The cloth appears then to be covered with red spots. Since a large number of the shades upon silk are produced by combining a number of colors it follows that if any constituent of the glue affects any one of these colors, a change either in the shade or the nature of the color is affected, spoiling the goods. On the other hand if unbleached glues are used, the brilliance so much desired upon silks will be lost.

Black silks are often treated with a mixture of oil, acid, soda, and glue as a finishing process to dispel the fuzziness resulting from the drying process. The color of the glue is not of great importance here, but it must be clear. Gelatin or clear dark brown glues are frequently used for this purpose.

Glue is used on cotton goods and on cotton batting to stiffen the material. The sizing solution is applied at one end of a machine, and the goods are expected to emerge, after passing through a drying chamber heated to 200°F., in a dry condition. There is difficulty in obtaining exactly the correct consistency of glue for this purpose. If the latter is too thin it will penetrate the pores of the cotton fiber to such a degree that the latter will be altogether too stiff to use, while if it is too viscous it will not be absorbed at all, and will fail to dry out during its passage through the drying chamber. To obtain the desired results it is common practice to treat a very dilute solution of a medium grade clear glue with a solution of alum. The alum thickens the solution and is satisfactory, provided no precipitation results. Many glues are, however, precipitated with alum, and unless a given glue is found by preliminary test to remain clear for several hours at least after the addition of alum it should not be subjected to such treatment in the plant.

Carpets, tapestries, burlap wall coverings, curtains, etc., are all heavily sized with glues. Where stiffness is desired as in window curtains a strong high grade glue is used. Otherwise dilute solutions of low grade hide or bone glues are employed.

All straws used in the manufacture of hats are heavily sized. In this case a product that is more or less resistant to the action of water is desired, and certain hardening agents are commonly added to the glue solution, prior to its application, for this purpose. Formaldehyde, potassium bichromate, tannin, and alum are employed. The glue used must be very clear and light colored or the straw appears yellow and "shop worn." A final bleaching is often given the material, after applying to the straw, by the use of sulphur dioxide, hydrogen peroxide, or oxalic acid.

**The Sizing of Wooden Containers.**—Barrels and casks that are to be used as containers for liquids are sized with some material before use, as otherwise the liquid would penetrate the wood and be lost, besides resulting in a decay of the wood. Where the liquid to be stored is of an aqueous type, glue is not well adapted on account of the softening and swelling it undergoes in water, but for the sizing of oil-containing barrels it serves very well. A first treatment is given to fill all of the cracks and imperfections, and a second to size the whole inner surface. A few quarts of the glue in solution are introduced into each barrel and steam applied under a low pressure to force the solution well into the pores of the wood. The barrels are rotated and finally drained while still hot.

**Glue as a Size in Paints and Calomine.**—A large amount of glue is diverted to the painters' trade. It is employed both as a size for the treatment of walls prior to the application of paint, merely to fill up the pores of the wall, for which work a cheap low grade of bone glue is satisfactory, or it may be mixed with a little paint, an insoluble base, and water, in the preparation of a calomine. For the latter service glues that have been rendered opaque by the addition of some white filler as calcium carbonate, zinc oxide, or lead carbonate have been most used. In the higher grades of these calomines which must be used with hot water high grade glues are used, but for the cheaper cold water products low grades are employed.

Prepared sizes are obtainable which contain mixtures of glue with chalk, clay, whiting, or some other material. These are made ready for use by the addition of boiling water. In the preparation of such mixtures it must previously have been ascertained that no residual salts are contained in the glue that might react with any constituent of the mixture. Glues of low

viscosity are preferable provided that sufficient strength is developed to bind the basic material of the size.

#### 4. GLUE AS A BINDING AGENT

A considerable quantity of glue is used in the manufacture of *matches*. The pieces of wood are dipped into a mixture containing the several ingredients for the ignition of the head upon "striking," together with a porous material such as plaster of paris, ground glass or sand, and glue to serve as a binder and to secure portions of the mass to the head of the match. The igniting constituents may include a sesqui-sulphide of phosphorus, elementary phosphorus, potassium chlorate, lead oxides, manganese dioxide, and other chemicals. Since phosphorus is easily oxidized by the oxygen of the air the glue must also be sufficiently strong to form a firm film about the mass to exclude the air, and no chances may be taken of the rubbing off of this film in the handling of the product. This latter obligation requires the use of a moderately strong glue, which also should be rather viscous. The admixture with the chemicals mentioned necessitates the use of a product free from any material which might react with any of the constituents of the mixture, or which could possibly oxidize the phosphorus. Low test bone glues have, however, been occasionally used.

*Sand papers* and *Emory papers* are also large consumers of a high grade of hide glue. The demand is primarily for glues of the highest attainable viscosity, but a strong jelly strength is also deemed important. The paper is passed between rollers which supply a rather concentrated solution of the glue to the upper surface, and the sand or emery (garnet, carborundum, alundum, etc.) of the selected size of grain is sprinkled profusely upon it. The excess of sand is shaken off and the paper then passed slowly along to a second set of rollers which it reaches in about a half hour. In passing through this second set it is again treated with a layer of the same glue, but of a weaker concentration, which binds the sand firmly that it may not become easily loosened. The paper is then passed slowly over heated pipes for about an hour and then wound into rolls, or cut to appropriate sizes and baled.

Glue is also used to a limited extent as a binder for *abrasive wheels*, only the highest grades being considered sufficiently reliable for this purpose.

*Artificial leather* contains glue as an important constituent. In one process Italian hemp and coarse cleaned wool are finely cut and carded together, being formed into wadding. This is felted by packing in linen and treatment with hot acid vapors. The product is washed, dried, and impregnated with a mixture the composition of which varies according to the type of material to be produced. For imitating a sole leather the following mixture is made: 50 parts of boiled linseed oil are mixed with 20 parts of calophony, 25 parts of French turpentine, 10 parts of glycerin, and 10 parts of vegetable wax, and the whole heated on a water bath with a little ammonium hydroxide. When the mass has become homogeneous, 25 parts of a very high grade glue soaked in an equal weight of water, and a casein solution made by dissolving 50 parts of moist freshly precipitated casein in a saturated solution of 16 parts borax, and adding 10 parts of potassium bichromate, are added, and the mixture boiled until it becomes sticky. After impregnating the felt in this mixture it is allowed to dry for 24 hours, then laid in a solution of aluminum acetate, dried, and finally pressed between hot rollers.

*Moulding material* is made from a mixture of basic lead carbonate (white lead), calcium sulphate, sawdust, and glue, and is used extensively in making moldings for picture frames, mirror frames, rosettes, etc. Other plastic substances such as dolls, toys, ornaments, and the like are made of materials in which glue is an important constituent. A very hard horny substance is made of 50 parts glue, 35 parts rosin or wax, 15 parts of glycerin, and 30 parts of zinc oxide or other earthy material. By increasing the glycerin and lowering the rosin content, a softer material results.

*Billiard balls* are made by dissolving 90 parts of glue in a minimum of water, and adding 5 parts of barium sulphate, 4 parts of calcium carbonate, and 1 part of linseed oil. A small ball is formed and allowed to dry. This is then made larger by adding another layer and again drying. This process is repeated until the ball is as large as desired. This is allowed to dry for 3 months and then turned. The finished ball is immersed in a solution of aluminum sulphate for an hour, dried, and polished for use.

*Composition cork* employs glue or gelatin as the binder. The cork is first softened, then dried and ground to the size desired, this being usually about  $\frac{3}{16}$  of an inch in diameter. The ground



cork is then warmed and mixed in a machine with a glue-glycerin mixture for about 30 minutes, or until the latter is thoroughly incorporated into the cork. At the end of the mixing a little paraformaldehyde is added and well stirred in. The mass so prepared is placed in a cold room to be drawn upon as needed.

The glue or gelatin used is usually of a high grade. The glue mixture is prepared by dissolving from 40 to 60 parts of the glue or gelatin in from 60 to 40 parts respectively of a mixture consisting of about 55 per cent glycerin and 45 per cent water. The amount of paraformaldehyde added at the end of the mixing is slightly less than 1 per cent of the weight of dry glue or gelatin used. This serves both as a hardening agent to render the product water resistant, and as an antiseptic. From 10 to 30 per cent by weight of the glue-glycerin binder is incorporated into the cork.

One of the principal uses of this cork mixture is in the manufacture of disks for sealing foods preserved in glass jars. For this purpose the mixture is stuffed into iron cylinders, baked at 100°C., for 3 or 4 hours, then forced out by rods, and cut with circular knives into thin disks. These are immersed in paraffin, centrifuged, and cooled.

Thick cork sheets are also made of the mixture for use as gaskets, washers, and insulation between steel plates.

An *imitation of hard rubber* is prepared by mixing a thick solution of glue with a solution of sodium tungstate in hydrochloric acid. A heavy precipitate forms of gelatin tungstate which is said to be sufficiently pliable and elastic at a temperature of 86 to 104°F., to permit of being molded, or drawn into sheets. On cooling, it becomes hard and brittle, but again becomes soft on heating.

## 5. GLUE AS A COLLOIDAL GEL

*Printing rollers* are made up with a combination of a high grade of hide glue and glycerin, or some other substance added to give the product elasticity and springiness. A composition used by one large plant is made by soaking 16 parts of gelatin in the same weight of water, and after melting adding 24 parts of linseed oil at 65°C. After these are well mixed 20 parts of molasses and 1 part of calcium chloride are stirred in, and the whole digested at 90°C., for three hours. For especially tough compositions,

a mixture of 2 parts of rosin dissolved by warming in linseed oil is added to the above. The substitution of bismuth carbonate for calcium chloride is said to make the product non-absorbent of water. Another composition is made by dissolving 32 pounds of gelatin and 4 pounds of glue in water, and adding 4 pounds of glucose, 72 pounds of glycerin, and 1 ounce of methylated spirit. After digesting for 4 to 6 hours it is cast into rollers. This composition is said to be unaffected by temperature, to retain its elasticity, and not to shrink. Formaldehyde is frequently added to assist in keeping the roller firm and insoluble in water.

Dawidowsky<sup>1</sup> gives the following formulas as expressive of the types of material entering into the composition of printing rollers.

TABLE 61.—THE COMPOSITION OF PRINTING ROLLERS

Glue.....	8	10	4	2	32	2	1	3
Molasses.....	12	..	8	1	12	6	2	8
Paris white.....	1	..	..	..	..	..	..	1
Sugar.....	..	10	..	..	..	..	..	..
Glycerin.....	..	12	..	..	56	..	..	..
Isinglass.....	..	1½	..	..	..	..	..	..
India rubber in naphtha.....	..	..	..	..	10	..	..	..

*Hectograph plates* are manufactured by causing a glue or gelatin-water-glycerin mixture to adhere to oiled paper or cloth. The latter in widths varying between 8¾ and 20 inches, is allowed to unwind from the roller which dips into a mixture of the glue solution. After passing between another set of rollers adjusted so as to leave a uniform rather thick ( $\frac{1}{16}$  inch) layer of the glue upon the paper or cloth, the latter is cut into lengths of about 14½ feet and transferred to shelves for drying. From 2 to 6 hours are allowed for the sheets to become sufficiently dry. They are then spread on the under side with oil or upon the jelly side with talcum powder to prevent sticking upon rolling, and spindles fastened to each end of the sheets by means of cloth strips. The sheets are then rolled upon the spindle and are ready for service.

Steinitzer<sup>2</sup> gives the following formulas as representative of

<sup>1</sup> DAWIDOWSKY, "Glue, Gelatin, etc." (1905), 157.

<sup>2</sup> F. STEINITZER, *Kunststoffe*, 4 (1914), 161.

the composition of the glue mixtures that are commonly successfully employed:

TABLE 62.—COMPOSITION OF HECTOGRAPH PLATES

Glue or gelatin.....	15	10.0	25	10
Water.....	20	40.0	50	20
Glycerin, 30°Bé.....	60	50.0	90	50
Kaolin, kieselguhr, etc.....	..	2.5	10	10
Sugar.....	..	....	10	..

In addition to the above ingredients a small amount of some hardening agent as formaldehyde, alum, potassium bichromate, or tannin, is usually added, and a little salicylic acid or other preservative may be introduced, although Steinitzer claims the latter is not necessary as the glue-glycerin mixture is in itself resistant to bacterial or other decomposition.

In general, only the high grades of hide glue or gelatin are used for hectograph plates.

*Artificial silk* has been prepared which consists entirely of a very high grade of glue or gelatin, treated with potassium bichromate to render the product insoluble, pliable, and firm. The solution is forced through fine holes by a strong pressure, and the resulting threads, after being rendered insoluble by exposure to the sun, are dyed if desired, dried, and woven into cloth. Water makes the product limp but it again becomes firm upon drying.

*Artificial ivory* has in the last few years come into very popular use. It is made essentially of the constituents which have been found to exist in the natural material. The following formula is illustrative of the method of manufacture: 300 parts of calcium oxide are treated with sufficient water to convert it into calcium hydroxide, but before the reaction is complete 75 parts of aqueous phosphoric acid are added, and this followed by 16 parts of ground calcium carbonate, 2 parts of magnesium oxide, 5 parts of aluminum oxide, and 15 parts of a high grade glue or gelatin dissolved in 20 parts of water. After a very intimate mixing the mass is allowed to stand for a day, and then pressed into the desired form in molds and dried in a current of air at 65°C. About 3 or 4 weeks of curing are then necessary before the product is perfectly hard.

*Gelatin veneers* is a name given to preparations of glue with earthy material by which imitations of marble, mother of pearl, lapis lazuli, malachite, ivory, tortoise shell, travertine, etc., may be made by a proper coating of a board or stone or piece of glass or crockery with the "veneer" desired. The marble or glass is made of the shape required, and glass surfaces should be ground. All surfaces are chalked and rubbed dry.

For imitating *marbles* and *enamels*, a glue solution made from a high grade of glue and containing finely ground zinc oxide is poured upon the prepared surface, placed in a horizontal position. The design required is traced with a glass rod, and glue solutions that have been colored by the appropriate dyes are poured on to conform with the design. If the color design is to be blended, the solutions should not be too thick, and should be poured on in quick succession, after which they are caused to intermingle as desired by the use of a glass rod. Imitation *malachite* is prepared in the same manner, except that the glues used are colored various shades of green.

For *mother of pearl* a small amount of silver bronze is mixed with the clear glue solution, and traces of anilin colors, especially those producing fluorescent colorations, are added to different portions of the glue. Portions are poured successively into a prepared glass plate and the pattern produced by deft manipulation of a comb or other instrument.

The layers of imitation marble or other material prepared as above are allowed to dry for a few hours and then placed downward upon another set of plates prepared in the same manner except that only clear colorless gelatin is used in the second set. These are allowed to remain for a few hours after which time the first plate is removed by lifting off from the lower layer, loosened by a knife. The veneer is then thoroughly dried by placing the other plate in a drying room and when hard is removed by carefully detaching the gelatin with a knife. The veneers, now free of glass, are trimmed and may be applied to any article by cementing with clear glue in the usual way. Exceedingly fine imitations have been made by this procedure.

## 6. GLUE AS A PROTECTIVE COLLOID

A high grade of glue or gelatin has often been found to be of great value in *electro-metallurgic processes* for the production of



smooth hard deposits in electrolysis. Betts<sup>1</sup> found that in the refining of silver from solutions of silver dithionate ( $\text{Ag}_2\text{S}_2\text{O}_6 \cdot \text{H}_2\text{S}_2\text{O}_6$ ), the deposit was greatly improved by the addition to the bath of one part of gelatin or of gum arabic to 120,000 parts of the silver solution. By employing a solution of silver methyl sulphate the addition of one part of gelatin to 12,000 parts of solution influenced the deposit favorably. Kern<sup>2</sup> reports favorable results in the deposition of tin from all electrolytes when gelatin is present to the extent of one gram in 500 c.c. of solution. Müller and Bahntje<sup>3</sup> found that gelatin and egg albumin improved the electrolytic deposition of copper from solutions of acid copper sulphate. By using a current density of 0.0033 ampere per square centimeter gelatin produced numerous vertical bands or stripes "just as though molten metal had flowed down the plate, solidifying on its way." By increasing the current density the bands became wider until at 0.035 ampere per square centimeter brilliant homogeneous deposits of high reflecting power were obtained. The action of gelatin as a protective colloid preventing crystallization is offered as the explanation of its favorable action.

The knowledge that the addition of certain colloidal substances, or even some non-colloids, to metal electro-depositing solutions will prevent the spongy, branching forms and make for smooth hard deposition is not a recent discovery, but has been applied for a long time. The explanation, however, is even yet incomplete. Gelatin, for example, when added to a solution of lead fluosilicate, which ordinarily deposits a loose mass of lead crystals, will cause a solid deposition, while gum arabic and many other colloids have no effect whatsoever. Gum arabic, on the other hand, is somewhat more effective than gelatin in improving the deposition of silver from solutions of silver dithionate. Some non-colloids are as effective as colloids, while most of such are ineffective. Pyrogallol and resorcin, for example, are nearly as effective as gelatin in the lead deposition mentioned, while carbon disulphide is most favorable in the case of silver methyl sulphate. In the presence of nitric acid, gelatin no longer exerts an appreciable influence, but in other acids it functions properly. This, taken with the effectiveness of pyrogallol and

<sup>1</sup> A. BETTS, *Trans. Am. Electrochem. Soc.*, **8** (1905), 121.

<sup>2</sup> E. KERN, *ibid.*, **33** (1918), 155.

<sup>3</sup> E. MÜLLER and P. BAHNTJE, *Z. Electrochem.*, **12** (1906), 317.

resorcin, seem to indicate that the reducing action of these substances determines their value in this connection, and, as soon as this reducing action is destroyed, the effectiveness of the added substance is lost. Betts<sup>1</sup> is convinced that a difference in the electromotive force set up in the hollows and on the ridges of an electro-deposit, due to the former enclosing a weaker solution than is adjacent to the projecting points, accounts for a rough deposit, while the addition of gelatin would lessen this difference and so make for a smooth deposition.

A somewhat simpler explanation is offered by Bancroft.<sup>2</sup> He states that "other conditions being the same we shall get the smallest crystals, the greater the potential difference between the metal and the solution. The addition of glue or similar substances to a solution tends to make precipitates come down in a colloidal form. Following out this analogy we should expect to find that addition of glue or similar substances to an electrolytic bath would decrease the size of the metal crystals, the limiting concentration being that at which the added substance causes a bad deposit owing to its chemical properties." Bancroft found that the addition of 10 grams of glue per liter of acidified copper sulphate solution improved the quality of the deposit.

In *rubber* glue is finding extensive application. It seems that glue is capable of replacing the rubber to the extent of 10 to 20 per cent without any very appreciable loss in the desirable qualities of the product. The glue may be brought into solution in a minimum of water to which a small amount of formaldehyde has been added to prevent decay. The water is then evaporated off until a very thick solution results. A quantity of rubber equal to that of the dry glue is then mixed into the mass and the mixture again evaporated until practically free from water. This material is then added in whatever quantity is desired to a batch of rubber, but if more than 20 per cent of the rubber is replaced by glue the product begins to show loss in strength and elasticity.

This use of glue is of especial significance since the very lowest grades appear to be nearly equal in value for this purpose to the higher grades. The nearly anhydrous finely powdered glue made by drying slowly on steam-heated rollers has recently come into extensive use for this purpose. When this material is used it is mixed directly into the rubber without first being brought

<sup>1</sup> A. BETTS, *Trans. Am. Electrochem. Soc.*, **8** (1905), 53.

<sup>2</sup> W. D. BANCROFT, *ibid.*, **6** (1904), 27.

into an aqueous solution, which offers a decided advantage in plant practice.

Technical comparisons of the several effects of different ingredients going into the manufacture of rubber have been presented by Wiegand.<sup>1</sup> These include carbon black, lamp black, china clay, red oxide, zinc oxide, glue, lithophone, whiting, fossil flour, and barytes. These were added to a basic mixture consisting of 100 parts of fine Para rubber, 30 parts litharge, and 5 parts sulphur by weight. The effect of these substances on the stress-strain curve (elongation plotted against breaking load in grams per square millimeter) showed barytes to have no effect whatever, except as a diluent, while carbon black, at the opposite extreme, showed a downward progression of the curves towards the load axis indicating greater and greater toughness, without sensibly altering the breaking tensile strength. Glue is about intermediate between these two. Up to 20 volumes there was a definite displacement of the curve indicating that glue is not a mere diluent, like barytes, but exerts a definite stiffening or toughening action. The tensile strength at break is, however, lowered.

Wiegand furthermore makes the assumption that the energy absorption in all cases may be represented by the area contained between the stress-strain curve and the elongation axis. By measuring this area with a planimeter and calculating the results to foot-pounds per cubic inch of original stock, he finds that the basic mixture "stored up" 450 foot-pounds. The addition of barytes, fossil flour, glue, whiting, and red oxide all constantly diminished the energy content with increasing amount added. China clay produced a slight increase, zinc oxide and lamp black showed marked increases, and carbon black up to 25 volumes increased the energy content up to nearly 150 per cent of its original value.

The results obtained in both cases point to a concise parallelism between the specific surfaces, or size of the individual particles, and the effects produced. The surface, in square inches per cubic inch, developed, for example, by barytes was found by direct measurement to be 30,480; for glue 152,400; and for carbon black, 1,905,000.

The above data may be summed up in the following table of Wiegand:

<sup>1</sup> W. B. WIEGAND, *Can. Chem. J.*, 4 (1920), 160.

TABLE 63.—EFFECTS OF VARIOUS SUBSTANCES ON RUBBER

Substance added	Apparent surface	Displacement of stress-strain curve	Total energy of resilience	Volume increase at 200 per cent elongation, per cent
Carbon black.....	1,905,000	42	640	1.46
Lamp black.....	1,524,000	41	480	1.76
China clay.....	304,800	38	405	....
Red oxide.....	152,400	29	355	1.9
Zinc oxide.....	152,400	25	530	0.8
Glue.....	152,400	23	344	....
Lithophone.....	101,600	..	...	....
Whiting.....	60,950	17	410	4.6
Fossil flour.....	50,800	14	365	3.5
Barytes.....	30,480	8	360	13.3
Basic mixture.....	.....	..	450	....

In *acid pickle baths* which are employed for cleaning and removing scale from iron and steel, especially just prior to galvanizing, glue has been found of value. It apparently greatly lessens the consumption of acid, while giving results quite as satisfactory from the point of view of the cleansing action obtained as the untreated solution.

*Foamite* is a substance employed in connection with the carbon dioxide generating fire extinguishers for use especially on oil fires. A small amount of a foamy glue is added to the solution in the tank, and the carbon dioxide, formed by the customary action of the acid on the carbonate results in the production of a heavy foam. This foam settles upon the oil and is not dissipated with anything like the rapidity that would be the case were the carbon dioxide not entangled in films of glue. The material is in consequence especially efficacious for such service.

*India ink* consists of very finely divided carbon suspended in water containing a little glue or gelatin, or some other colloidal material. The pure finely divided lamp black is made into a thick paste with a dilute solution of the glue containing a little musk or ambergris, and then moulded and dried. In order to make the ink stand up better in service, *i.e.*, to prevent a blotting upon passing a damp brush over the lines, about 1 per cent of potassium bichromate may be added in the dry finely powdered state to the paste.



## CHAPTER XII

### THE USES AND APPLICATIONS OF GELATIN

A wound is glued together  
by myrrh, incense, and gum.  
Celsus (about 200 A.D.)

	PAGE
I. Edible Gelatin. . . . .	556
1. Gelatin as a Food. . . . .	556
2. Gelatin as a Protective Colloid in Dietetics. . . . .	558
The Infant and Invalid Dietary. . . . .	558
Gelatin in Ice Cream and Other Food Products. . . . .	561
3. Gelatin as an Emulsifying Agent. . . . .	567
4. Isinglass and Gelatin in Fining. . . . .	569
5. Gelatin in Pharmaceutical Preparations. . . . .	569
II. Commercial Gelatin. . . . .	571
1. Gelatin in Photography and Photolithography. . . . .	571
2. Gelatin as a Bacterial Culture Medium. . . . .	574
3. Gelatin Cells for Ultrafiltration. . . . .	575
4. Gelatin in Analytical Procedures. . . . .	576
5. Gelatin as a Medium for Demonstrating Colloidal Phenomena. . . . .	576

An attempt is made in the preceding and present chapters to distinguish between glue and gelatin on the basis of refinement rather than upon jelly consistency, viscosity, or any other physical property. The highest grades of glue are by physical tests quite the equal of the pure gelatins, and many uses that have commonly been attributed to gelatin solely on account of the usually higher tests of the latter, are in this text credited under glue. By gelatin we prefer to imply a material that has either been made under conditions of such rigid sanitary specifications that it may properly be classed as *edible* or *medicinal*, or else a high grade of glue that has been further treated so as to produce a product that is very close to a chemically pure *protein gelatin*. The latter may not, however, be "edible," but is utilized for the arts requiring a highly refined product.

The most important uses of pure gelatin are as a food and protective colloid in dietetics, in photographic preparations, and in pharmaceutical products.

## I. EDIBLE GELATIN

1. **Gelatin as a Food.**—The rôle of gelatin in animal economy has been studied by a number of able physiologists and in the light of their findings there is no question of the value of gelatin in the dietary. We are not however permitted to regard this delicacy as the equivalent, in the sparing of protein tissue in the body, of the combined proteins, such as are found in milk, meat, eggs, etc.

That it functions as a true food seems satisfactorily proven, but it appears to be incapable of supplying more than about a third to a half of the required nitrogenous matter necessary to maintain a nitrogen equilibrium in the body. Thus Kirchmann<sup>1</sup> reported that if gelatin is included in the diet to the extent of 12 per cent of the required energy, the decomposition of body protein, or the requirement of other proteins necessary for equilibrium, is lessened by 27 per cent, but further increases in the administered gelatin failed to diminish the protein katabolism proportionately. For example, gelatin to the extent of 62 per cent diminished the protein decomposition by only 35 per cent. This was the maximum obtained. Up to 12 per cent practically all of the gelatin was absorbed, traces only being found in the faeces.

Krummacher<sup>2</sup> expresses his results in a slightly different form. He found that the protein decomposition in dogs during gelatin feeding was 62.6 per cent of that which is broken down during inanition. In the average man the amount of protein which undergoes katabolism in a day is 70 grams. If gelatin is given to the extent of its maximum effect, assuming the same relationship for man as for dogs, 33 grams of gelatin will reduce the katabolized protein to 56 grams, or 33 grams of gelatin will spare 14 grams of protein. Krummacher reports the heat value of gelatin as 5.3676 Cal., and upon deducting the value of the unburned products in the urine and faeces it leaves 3.8835 Cal. or 72 per cent of the total energy available. The available energy in meat protein has been placed at 74.9 per cent by Rubner, which is but little greater than that found for gelatin.

Murlin<sup>3</sup> observed that protein nitrogen might be replaced by

<sup>1</sup> J. KIRCHMANN, *Z. Biol.*, **40** (1900), 54.

<sup>2</sup> O. KRUMMACHER, *Z. Biol.*, **42** (1901), 242.

<sup>3</sup> J. MURLIN, *Proc. Am. Philol. Soc.*, **29** (1904).

gelatin up to a half of the starvation requirement, while as much as two thirds may be replaced provided carbohydrates are present in such amounts as to provide a half to two thirds of the total calorific requirement.

Some effort has been directed at an explanation as to why gelatin could not be substituted completely for other types of protein in animal economy, and the conclusions of these studies indicate that its failure in this respect lies in the absence of certain specific and necessary amino-acid residues. Thus tyrosine, cystine, and tryptophane are practically absent in gelatin. Kauffman<sup>1</sup> adopted this explanation with such confidence that he carried on a series of experiments to test the point, not only upon the proverbially unfortunate dogs, but also upon himself. He reports that gelatin may be substituted for protein normally to the extent of 20 per cent without harm, but that "this can be exceeded and the protein completely replaced by gelatin if the latter is mixed with tyrosine, cystine, and tryptophane. . . . Both dogs, however, died." An eminently successful experiment. Sherman<sup>2</sup> also came to the belief that although the absence of glycine from the products of hydrolysis of a protein was of no significance as regards its nutritive value, yet the absence of more complex radicals such as tryptophane, tyrosine, etc., seriously affected its ability to completely replace katabolized body protein.

Murlin<sup>3</sup> came to the conclusion that any carbohydrate which was not needed for satisfying the energy requirement was much more efficacious in reducing the nitrogen output than that which was necessary for combustion. He affirmed that the sparing action of gelatin is not due to any dextrose that it may give rise to, but to its content of nitrogenous residues. Glycine, which is the chief amino-acid constituent of gelatin, can be retained temporarily in the body, and so may serve to account for the high replacement of other proteins by gelatin. Glycine is not retained permanently, however, even in the presence of an abundance of carbohydrate.

Many other contributions have appeared upon this subject and in every case the conclusions point to the insufficiency of gelatin as a *complete* protein food. But many other pure pro-

<sup>1</sup> M. KAUFFMAN, *Pflüger's Arch. Physiol.*, **109** (1905), 440.

<sup>2</sup> H. C. SHERMAN, "Chemistry of Food and Nutrition" (1913), 302.

<sup>3</sup> J. MURLIN, *Am. J. Physiol.*, **20** (1907), 234.

teins, as albumin, fibrin, etc., are also incomplete, and it should be emphasized that in a normal diet where a great variety of ingredients go to make up the dietary the need for a complete food being embodied in any one material is quite negative and a matter of indifference. As one of a variety, however, there can be no reasonable objection raised to the inclusion of a pure gelatin, for it is a true food, a preserver of nitrogen, is easily digested, and is readily burned in the production of energy. The additional value of gelatin in the diet as a protective colloid is described in the following section.

**2. Gelatin as a Protective Colloid in Dietetics.**—Many colloidal substances and most suspensions are readily precipitated from solution by the addition of electrolytes. This is especially true of the suspensoid type of colloid such as the colloidal metals, sulphides, oxides, etc., but some proteins are similarly affected. For example, the casein of cows' milk is coagulated as soon as the *bacterium lactis acidi* has produced a certain small amount of lactic acid, or by the direct addition of a very little mineral or organic acid. There are some colloids, however, that are not only practically uninfluenced by the addition of electrolytes, but that possess the striking and important property of being able to stabilize colloids that are normally easily precipitated, so that a very much greater concentration of electrolyte is required to bring about a coagulation. Exceedingly small amounts of these colloids are able to protect very large volumes of otherwise unstable material.

*The Infant and Invalid Dietary.*—When the casein of milk is separated from the other constituents it is found very difficult to bring it into a state of colloidal solution, for even traces of electrolytes suffice to precipitate it. An examination of the whole milk shows that it contains:

In true solution	In colloid solution	In suspension
Lactose	Casein	Milk fat
Mineral salts	Lactalbumin	

and the proportion of these constituents is found to vary in different animals. The stability of the milk and its resistance to the action of acids is found to be proportional to the content of lactalbumin, as shown in the following table by Alexander and Bullowa.<sup>1</sup>

<sup>1</sup> J. ALEXANDER and J. BULLOWA, *J. Am. Med. Assn.*, 55 (1910), 1196.



TABLE 64.—COMPOSITION OF MILK FROM DIFFERENT SOURCES

Kind of milk	Casein	Lactal- bumin	Fat	Sugar	Behavior with acids and rennin
Cow.....	3.02	0.53	3.64	4.88	Readily coagulated.
Woman.....	1.03	1.26	3.78	6.21	Not readily coagulated.
Goat.....	3.20	1.09	4.78	4.46	.....
Ewe.....	4.97	1.55	6.86	4.91	.....
Mare.....	1.24	0.75	1.21	5.67	.....
Ass.....	0.67	1.55	1.64	5.99	Not readily coagulated.

The order of digestibility also corresponds with the content of lactalbumin, according to Jacobi,<sup>1</sup> who finds that asses' milk may often be fed with success to infants who are unable to digest either cows' or woman's milk.

The specific action of the lactalbumin is obviously as a stabilizing agent<sup>2</sup> which keeps the casein moiety in a finely divided state, and prevents a coagulation of the latter even upon reaching the stomach with its acid secretions. The ultramicroscope has revealed that the size of the casein particles is much smaller in woman's than in cow's milk. It has also shown that flocculation is almost entirely inhibited in cow's milk upon the addition of small amounts of acid if a little gelatin is previously added. This experiment, also confirmed by the extraordinary small "gold number" of the gelatin,<sup>3</sup> makes it appear certain that gelatin is capable of functioning as a protective colloid, in conjunction with lactalbumin, in preventing coagulation of milk during digestion. Jacobi<sup>4</sup> advocated the addition of gelatin or gum arabic to cow's milk for infant feeding as early as 1889 and, although the exact nature of the action was not then understood, the beneficial results obtained by such practice were well known. It is very probable also that gelatin functions in keeping the fat in a finely divided condition. When casein is precipitated it carries down with it a considerable portion of the fat, and troubles that have been experienced by an appearance of undigested fat, may be due in fact to fat precipitation by the casein.

<sup>1</sup> A. JACOBI, *ibid.*, 21 (1908), 1216.

<sup>2</sup> Cf. J. ALEXANDER, *Z. Chem. Ind. Kolloide*, 4 (1909), 86; 5 (1909), 101; 6 (1910), 197.

<sup>3</sup> See page 123.

<sup>4</sup> A. JACOBI, "The Intestinal Diseases of Infancy and Early Childhood," 1889.

It must be urged that gelatin will not in all cases entirely prevent the formation of casein curds in the stomach. The acidity may become sufficiently high to produce coagulation in spite of the protective colloids present, but these undoubtedly are of value in retarding and diminishing this undesirable phenomenon. In fact the size of the flock produced, rather than the entire absence of any curd, is probably the more important aspect clinically, for if the curd is finely divided and soft, the enzymes of the digestive tract will be easily able to dissolve them, whereas if large hard lumps are formed the enzymes may have but little effect upon them. Koplik<sup>1</sup> states that the equilibrium between the acid content of the infant's stomach and the protective colloid content of woman's milk is such that coagulation takes place late, and in small soft masses, while upon the ingestion of cow's milk coagulation occurs early, and in large masses.

Herter<sup>2</sup> also finds the addition of gelatin to the milk in cases of serious malnutrition to be highly beneficial, and to result in a much greater absorption of the milk fed. The milk fat tends in such cases to coalesce into relatively large masses which are quite impossible of digestion in the infant organism,<sup>3</sup> and the amount of fat fed is often reduced to less than two per cent without greatly improving the case, while any successful attempt at preventing the coagulation of the casein is simultaneously reflected by a perfect digestion of the fat. Even in adults Moore and Krombholz<sup>4</sup> regard the ingestion of protective colloids in the form of albumins and gelatin as of the highest importance in maintaining an emulsion of the fats which are ingested, and in that way preventing digestive disorders that would result from the non-emulsification of fat masses.

Although investigations upon this subject have been largely confined to the single food milk and to its adaptability for infant feeding, the principle of colloidal protection must be of none the less great importance in many other foods, and in the normal dietary, as well as in that of the sickroom and the preparation of food for invalids. This important phase of dietetics has not been

<sup>1</sup> H. KOPLIK, "Diseases of Infancy and Childhood," 1902.

<sup>2</sup> C. HERTER, "On Infantilism from Chronic Intestinal Infection," 1908.

<sup>3</sup> J. SCHERESCHEWSKY, Hyg. lab. U. S. Public Health and Mar. Hosp. Service *Bull.* 41.

<sup>4</sup> MOORE and KROMBHOZ, *J. Physiol.*, 22 (1908), 54.

adequately investigated but there can be no doubt in the light of what has already been accomplished that the chemical constitution of a food is only one of a number of the factors which must properly be considered in the selection of a dietary. If the nitrogen supply is given wholly through the single protein albumin, or fibrin, or gelatin, the unfortunate victim will starve to death. If a perfectly balanced ration of heat sterilized foods is given, the same misfortune will result. We have discovered that a single pure protein is usually insufficient. We have discovered the hypothetical vitamins. We have observed that a certain association of foods may react in the body quite differently than a certain other association. And in this field lies the influence of the protective colloid. *In vitro* there is no colloid that exhibits this property of protection to the degree shown by gelatin, and the value of this substance as a part of the normal diet, especially to those who suffer from poor digestion, is probably far more as a protective colloid and emulsifying agent than as a food, but it functions unquestionably as both.

*Gelatin in Ice Cream and Other Food Products.*—Gelatin has long been used in the manufacture of ice cream, especially when made in large quantities by the larger manufacturers. There are a few states in which such use of gelatin is prohibited by law, but the old prejudice against gelatin due to its unrefined correlation with glue has fallen away with the advent of more sanitary and cleanly conditions of manufacture. When it is realized that upwards of 250,000,000 gallons of the frozen delicacy are consumed annually in the United States alone, and that a pound of gelatin is used for approximately each 50 gallons of ice cream, it is seen that the amount of gelatin which annually finds its way into the frozen cream is in the neighborhood of 5,000,000 pounds.

The advantages obtained by the use of gelatin in ice cream find explanation in three colloidal properties of the substance; (1) the ability of gelatin to produce a jelly at low temperatures, (2) the "protective" nature of gelatin, which prevents, or greatly diminishes, the tendency of other substances to crystallize or separate from the mixture, and (3) the ability of gelatin to function as an emulsifying agent, and so render more permanent the emulsion of the milk fat in its aqueous medium.

It seems to have been known for a long time that gelatin improved the texture and keeping qualities of ice cream,<sup>5</sup> but

exact experimentation on a large scale was not made until of comparatively recent date. R. M. Washburn<sup>1</sup> of the Vermont Agricultural Experiment Station, and O. E. Williams<sup>2</sup> of the Dairy Division, Bureau of Animal Industry, have made extended investigations upon the use of gelatin in ice cream.<sup>3</sup>

*The Improvement of "Body" and Texture.*—The ways in which gelatin acts beneficially in ice cream are three in number. Gelatin improves the "body" of the product, it improves the texture, and it improves the stability or keeping qualities. By "body" is meant the consistency, the firmness, the structure of the material. The ice cream should be firm and mellow, but not hard or rubbery. Where no gelatin is used the product will be weak, will yield easily to any slight pressure, will tend to be "crumbly," and not easily retain its shape. The jet from the soda fountain directed upon a portion of the frozen cream in a glass would scatter the cream into fine flakes, which, as Washburn says, "could be easily drunk as a gruel, but could not well be eaten." A small amount of gelatin, however, acts as a binder, making for the retention of shape, for consistency, and firmness. It is not desired to produce a real jelly, such as is sought in the familiar culinary desert. The presence of the gelatin would then be too manifest, and the taste of the public has not been trained to be satisfied with an ice cream that is of the consistency of a real jelly. For this reason the amount of gelatin which may be added is very small. A good grade of gelatin will produce a jelly, at or near the freezing point of water, in a 1 per cent concentration. A concentration of about a quarter of 1 per cent is adequate for the development of a marked beneficial effect upon the consistency and firmness of the ice cream, but is not great enough to produce the undesirable effect of transforming the ice cream into a jelly.

The second way in which gelatin has been found of advantage in ice cream manufacture is in its effect upon the *texture* of the product. This term refers to the "smoothness" of the cream. It is often incorrectly assumed that the fat content determines the texture, nearly to the exclusion of any other factor. If

<sup>1</sup> R. M. WASHBURN, Ver. Agr. Exp. Sta. Bull. 155 (1910).

<sup>2</sup> O. E. WILLIAMS, Paper read before Wisconsin Ice Cream Dealers Assoc., (1916).

<sup>3</sup> *Vide* also J. H. FRANDSEN, and E. A. MARKHAM, "The Manufacture of Ice Creams and Ices" (1919).



the ice cream is coarse, granular, crystalline, it is said to be thin, and poor in fat, while if it is of a velvety texture, it is said to be rich. Although the milk fat is a very important agent in the production of a smooth cream, it must be urged that it may be of only secondary importance. When the creams are freshly frozen, other factors being equal, the smoothness of texture will be proportionate to the milk fat present, but after the frozen cream has been allowed to stand for a day or two it will be found that the water, which in either case is present to the extent of 60 to 70 per cent, will begin to crystallize out in the form of sharp spiny crystals. Lactic acid may also crystallize out as granular sandy crystals.<sup>1</sup> These are very objectionable, both to the consumer, and, by virtue of a consequent loss in trade, to the dispenser of the cream. But gelatin has been found, when added in very small amounts, to greatly retard, or even entirely prevent, this crystallization of the water and the lactic acid.

The explanation of this action of the gelatin lies in the colloid nature of the material. It has been suggested that the gelatin forms a thin film around the other molecules in the solution, thus preventing them from coming into a sufficiently intimate contact with each other to carry out the reactions which otherwise would ensue. It is by the same property that gelatin prevents the ionic precipitation of salts, and the coagulation of milk by the acid of the stomach. It is another of the many examples which have been mentioned of the "protective" action of gelatin.

*The Improvement in Stability and Keeping Qualities.*—Of equally great, and perhaps greater, importance than the foregoing, is the influence of gelatin upon the stability and keeping qualities of the ice cream. When no gelatin is added, the material must be kept at a temperature of 18 to 20°F. in order that softening and a separation of the constituents may not take place. The fats in the cream being lighter, and the sugars being heavier, than the main mass of the ice cream, there is a tendency for the former to rise, and the latter to sink as soon as a softening takes place. All of these things are, of course, undesirable. When small amounts of gelatin are present the cream will remain in a firm condition at temperatures as high as 24°F. This is only a few degrees difference but it may mean much on a hot day. The steps through which a cream is passed between the manufacturer and the consumer may be many. In our American

<sup>1</sup> H. F. ZOLLER and O. E. WILLIAMS, *J. Agr. Research*, 21 (1921), 791.

method of doing business the ice cream industry has grown until it is no longer localized, but one large plant may, and often does, supply its frozen product daily to communities a hundred miles and more distant. In the course of transporting such a perishable product as ice cream to such distances it is obvious that a difference of a few degrees in temperature may be a margin of sufficiently important magnitude to make possible an undertaking which otherwise would have to be regarded as impracticable.

The presence of a small amount of gelatin makes it possible therefore, to keep the cream at a somewhat higher temperature without suffering the possibility of a melting, a disintegration, or a spoiling of the substance. This point finds an important bearing in the economic side of the business. As pointed out by Washburn,<sup>1</sup> melted cream is in some places taken back by the manufacturer, in order to hold his trade, and it has been a common practice of manufacturers to turn all melted cream back into the new batches, refreeze, and send out again. Thus old creams may repeatedly be permitted to contaminate the fresh lots, and putrefactive decomposition, with the development of ptomaines, has been known to result. The use of gelatin makes melting while in the hands of the retailer less likely to occur, and so discourages and renders unnecessary the return of melted lots to the manufacturer.

*The Effect upon Flavor and Swelling.*—The effect of gelatin upon the flavor of the frozen cream was especially studied by Williams.<sup>2</sup> He found that where a small amount of a high grade gelatin was used there was very little difference detectable between the creams with and without the gelatin. If rather large amounts of gelatin were employed, the fruit flavors are largely masked and rendered scarcely apparent. This, he says, "can be explained by the law of diffusion, and the physiological function of the organs of taste." It seems simpler to the physical chemist to say that the gelatin has adsorbed the flavoring principle. Whenever low grades of gelatin were used, there remained a characteristic and disagreeable after-taste, suggestive of glue. This sometimes occurred also with the higher grades of gelatin, but was undoubtedly due to a selection of gelatin produced from poor or partially decomposed stock. If the gelatin was

<sup>1</sup> R. M. WASHBURN, *loc. cit.*

<sup>2</sup> O. E. WILLIAMS, *loc. cit.*

prepared on one day, and not used in the cream until a later day, there was also produced an offensive taste. This results, of course, from a decomposition by bacteria which takes place very rapidly in a solution of gelatin at room temperature.

Upon using a gelatin that had been repeatedly heated, an ice cream resulted which showed a minimum of influence by the gelatin. That is, the hydrolyzed products, proteose and peptone, do not possess the beneficial properties which make gelatin desirable in ice cream.

It has sometimes been said<sup>1</sup> that gelatin imparts an increase in the swelling effect which results in the freezing of ice cream, but Washburn has reported that this is not the case. In fact a slight decrease in the swelling was observed. In 184 freezings without a binder he obtained an average swell of 63 per cent, while in 37 freezings with a binder the average swell was only 55 per cent.

*Objections to the Use of Gelatin in Ice Cream.*—There have been many objections raised against the use of gelatin in ice cream, but the most persistent of these is based upon the association which gelatin bears to glue, and the difficulty in disengaging the popular mind from the belief that gelatin and glue are one and the same material. The analogy is the same as would be met between the use, for the making of a soup, of a good clean fresh soup-bone, and of an indeterminate mass of skin pieces, heads, feet, ears, sinews, etc., of the same animal. The latter might be clean and undecomposed, but there would be, nevertheless, an aesthetic objection to partaking of a "dainty" soup or ice cream made from them. There is, of course, always a possibility that the gelatin used may be low grade material, and really unfit for culinary purposes, but it is just as pertinent to apply that same objection to meat, poultry, milk, and other readily decomposed substances. The use of any gelatin of questionable origin or purity should be most strenuously opposed, but the addition of a pure high grade gelatin need not be condemned because of a possible misuse of the privilege.

An indifference in the selection of the gelatin is altogether indefensible. The following table taken from Bulletin 134 of the Iowa Station shows the enormous differences that may exist in the bacteria content of different samples of gelatin, and of the ice cream made from the several samples.

<sup>1</sup> Cf. U. S. Marine Hospital Service, *Bull.* 41 (1908), 292.



At this place it should be emphasized that there is no economic advantage accruing to the manufacturer by the use of a low rather than a high grade gelatin. The low grade material costs less per pound, to be sure, but in order to obtain the same advantages of improved body, texture, and keeping qualities of the frozen cream, it is necessary to use much more of the low

TABLE 65.—BACTERIA IN GELATIN AND ICE CREAM

Sample number	Bacteria per gram	Bacteria in 1 c.c. of ice cream due to gelatin
1	113,000,000	656,000.0
2	14,000,000	70,000.0
3	35	0.2
4	4,200	21.0
5	85,000	425.0

grade gelatin than would be necessary of the high grade material. This larger amount and poorer quality would likewise make its presence in the cream much more easily detectable, even to the unobservant, by leaving an unpleasant taste in the mouth. This would certainly not react to the advantage of the manufacturer, especially if he were in competition with others. So the use of only the highest grade, and purest gelatins is equally important from the several points of view of the consumer, the manufacturer, and the Board of Health.

Other arguments that have been raised against the use of gelatin in ice cream are: That it conceals the age of the cream, that its use permits of a warmer and therefore less safe holding temperature, and that it is unwise to permit the use of any material in ice cream other than the cream, sugar, and flavoring substance. The age of the cream is concealed by gelatin because the latter substance prevents the crystallization of the water. Therefore a retailer may sell a cream several days old. That is true, but if no gelatin were added the cream would have become unsalable, and perhaps returned to the manufacturer, refrozen with fresh stock, and resold. It seems that a constant repetition of the latter procedure would surely be more harmful than the former.

A warmer temperature may be employed in handling an ice cream containing gelatin, but the maximum temperature of 24°F.



is still sufficiently low to prevent any untoward decomposition by bacteria.

That gelatin should be prohibited on the ground that it is an adulterant, regardless of its beneficial effect, is unjustified. If it were added for the purpose of concealing an inferior product, it should not be permitted, but as pointed out above, this is not the end sought in adding gelatin to ice cream.

*Other Applications of Gelatin in Food Products.*—Small amounts of gelatin are sometimes added to a number of food products for much the same purposes as have just been described for ice cream. In many such cases, however, gelatin may correctly be regarded as an adulterant. Fruit preserves, jams, and jellies occasionally contain gelatin added to give an appearance of a better quality of product. Meat extracts and similar preparations are often given a fictitious "body" with gelatin. Cream is occasionally made to appear thicker and richer by added gelatin. Chocolate and cocoa have been treated, at times with gelatin for the same purpose. Coffee beans have been dipped into a gelatin solution to impart to them a glaze which has been found to be pleasing to the eye.

**3. Gelatin as an Emulsifying Agent.**—The theory of emulsions has been described in Chap. IV, and it was mentioned in that place that gelatin is one of the most effective of emulsifying agents. Without the presence of some third substance which forms a film about the finely divided droplets of the internal phase (Bancroft), or which forms a solvated colloid in which the internal phase may become dispersed (Fischer), it is doubtful if emulsions of more than transient duration may be produced. But whatever the theories that are advanced to account for it may be, the third substance known as the emulsifying agent, is in practice a real and important constituent of all emulsions. The use of gelatin in this capacity is of great importance.

In the manufacture of emulsion flavors for the baking and confection trades gelatin may be employed. The emulsion will be increased in viscosity by cooling and is very stable. Some preservative is added to prevent decomposition. The addition of a little gelatin to a thin cream will make it easily possible to whip, and solutions sold for that purpose often contain gelatin and some vegetable gum which serves the same purpose. In the manufacture of marshmallows and other confectionary foams, gelatin is employed in much the same way, and gelatin and egg

albumin have both found service in baking powders and prepared flours to give increased openness of texture.

In the making of mayonaise dressings the whites of eggs or commercial egg albumin has been most used as the emulsifying agent causing the olive or cottonseed or corn oil to emulsify with water or vinegar or lemon juice. Gelatin may be substituted in some instances, however, without apparent detriment to the product. Fischer and Hooker<sup>1</sup> observe that "lasting emulsions of oil in gelatin are obtainable only by dispersing the oil in a gelatin mixture of a concentration which is just fluid at the temperature at which the experiment is carried out. If with such a gelatin colloid the temperature is raised (and its degree of hydration thereby decreased) a less permanent emulsion results. On the other hand, an emulsion of oil in gelatin remains fixed if the mixture is chilled to below the gelation point of the gelatin." The very favorable results obtained with gelatin in ice cream is probably due in part to the greatly increased efficiency of this colloid at low temperatures.

Fischer and Hooker have also used gelatin in the preparation of synthetic milk, but as the object in making this substance is primarily to produce an emulsion identical with the natural product, the milk proteins are more commonly added.

When ingested as a food, gelatin also undoubtedly functions as an emulsifying agent, as suggested in the previous section. Especially in the duodenum, upon mixing with the bile, the gelatin must greatly favor a complete emulsification of the fat, and a consequent active hydrolysis and assimilation.

In the preparation of non-edible emulsions such as are used for agricultural and industrial purposes, gelatin or a high grade of glue are also much used. Emulsions of the oil-in-water type are most commonly stabilized by the addition either of soap or gelatin as the emulsifying agent. Jones<sup>2</sup> has patented an insecticide and fungicide formed of 1.5 to 3 gallons of an emulsified mineral oil containing a small proportion of cresol soap, 5 to 15 gallons of lime-sulphur solution, 8 to 24 ounces of ground glue, and 100 to 200 gallons of water. Bordeaux mixture may be used with the same preparation in place of the lime-sulphur solution. Hedenberg<sup>3</sup> has advised the author that glue is used,

<sup>1</sup> M. FISCHER and M. HOOKER, "Fats and Fatty Degeneration" (1917), 33.

<sup>2</sup> P. R. JONES, U. S. Patent, 1,291,013, Jan. 14, 1919.

<sup>3</sup> O. HEDENBURG, personal communication.

together with casein and borax, and a preservative such as sodium fluoride, to emulsify finely divided sulphur in water when the sulphur may be present to the extent of about 50 per cent. Bourcart<sup>1</sup> states that Lodeman has applied glue to grape vines as a cure for *peronospora viticola*, mildew of the vine, and that Del Quercio has observed that an excellent method of destroying the woolly aphid, *schizoneura lanigera*, consists in coating colonies of the louse with a mixture of 1½ pounds of glue and 3 gallons of tar. Lodeman<sup>2</sup> states that glue is frequently recommended as a valuable addition to insecticides and fungicides to increase their adhesive properties, and gives a formula for a paris green mixture:

Glue.....	1 pound
Paris green.....	1 ounce
Water.....	2 gallons

David<sup>3</sup> used glue to the extent of 6 kilograms of strong glue to 800 liters of Bordeaux mixture with beneficial results.

**4. Isinglass and Gelatin in Fining.**—In the fining or clarification of beer, wine, vinegar, etc., a high grade of isinglass is usually used. This consists essentially of the swimming bladders of the sturgeon and other fishes, and comes into service in the form of the original membranes, washed and laid one upon another until a thick leaf is produced.<sup>4</sup> This material is powdered or shredded and added to the liquid to be clarified.<sup>5</sup> The numerous fine flakes of the isinglass gradually settle to the bottom carrying with them the colloiddally dispersed particles which had given the liquid a turbidity. The temperature of the mixture must be kept low during this process as a solution of the isinglass would be disastrous to the object in view. A high grade of gelatin, ground into a powder, is also sometimes used but lacking the fine membranous structure of the isinglass is not nearly as efficient as the latter. Its lower cost, however, is in its favor and where the highest quality of product is not required it serves very well.

**5. Gelatin in Pharmaceutical Preparations.**—When formalde-

<sup>1</sup> E. BOURCART—GRANT, "Insecticides, Fungicides, and Weed Killers" (1913), 382.

<sup>2</sup> LODEMAN, "Spraying of Plants" (1916), 147.

<sup>3</sup> DAVID, *J. agr. pract.* (1885), 661.

<sup>4</sup> *Vide* page 350.

<sup>5</sup> *Vide* page 355.



hyde is added to a solution of gelatin a change is observed to take place in the latter which to a certain degree is dependent upon the amount of formaldehyde added. In amounts smaller than one part in 10,000 there is very little change observable. Added to the extent of 0.1 per cent a more viscous solution results but insolubility is not obtained in such a solution until the gelatin has been permitted to dry out. Added in greater concentrations formaldehyde produces a jelly that may not again be melted or brought into solution by heat or the addition of more water. This jelly differs from an ordinary gelatin gel in being rubbery and possessing less strength when cold. The dried and powdered product, known as *formo-gelatin* is employed as a surgical dressing. Due to the antiseptic action of the formaldehyde it remains sterile and is a germicide.

A small amount of formaldehyde is often added to glue or gelatin employed for printers rollers and hectograph plates, as it serves the double purpose of preventing any decomposition, and also of hardening the product, that the desired consistency may be maintained even in warm weather.

*Capsules* for use as containers of doses of medicine are used in very large quantities. They are made from a pure food gelatin by dipping into a strong solution of the latter containing a little glycerin or sugar, an iron rod, the end of which is shaped exactly as the capsules required. This end is highly polished so that the gelatin when cool may be easily detached. The dipping and cooling may be repeated until the desired thickness of capsule is obtained. After removing from the rod they are thoroughly dried and are then ready for use. In using them, the two sections are made so that one fits down over the other like a cover. By moistening the edges after filling the capsules, or by painting the edges with a weak gelatin solution containing a little gum, a perfectly tight joint is secured.

For *coating pills* gelatin is also much in favor. The object in this case is not only to eliminate the taste of the pill in swallowing but, depending upon the specific case, to prevent evaporation of enclosed moisture, to prevent crumbling, to prevent sticking together, or to prevent other undesirable changes taking place in the pill. A solution of about 1 part of gelatin to 2 parts of water, together with a little glycerin or sugar may be used. The pills are coated by dipping.

In Europe large quantities of gelatin are made into very thin



sheets of about the thickness of ordinary writing paper, called *gelatin foils*. A pure gelatin is brought into a rather dilute solution, a little glycerin added and if desired a little anilin dye, to give the product any required color. The solution is poured out upon a polished plate of glass, and rolled flat, or another plate of glass placed over the solution. After drying a few hours the upper plate is removed, and when thoroughly dry the gelatin may be peeled from the lower plate without difficulty. The foils are used for printing sacred images, labels, visiting cards, in the manufacture of artificial flowers, fancy articles, and for covering small wounds, as the material adheres to the skin and can be rendered antiseptic.

*Court plaster* is made from a mixture of gelatin, alcohol, and glycerin. The gelatin is dissolved in a small amount of water. A portion of this is spread upon taffeta and allowed to dry. This is repeated a few times, when alcohol and glycerin are added to another portion of gelatin, and a few more applications made in a similar manner. The reverse side is treated with tincture of benzoin.

Chromate gelatin has been used abroad, especially in Germany, as aluting for glass and cork stoppers in pharmaceutical containers. Alutes of this character have been replaced largely by cellulose-ester preparations.

## II. COMMERCIAL GELATIN

**1. Gelatin in Photography and Photolithography.**—A large amount of the highest quality of gelatin goes into service as a coating upon the films, plates and developing papers used in photography. This coating contains the silver salts and other constituents of the light-sensitive portion of the film. If the gelatin is not of the purest quality there will result reactions between it and the sensitive silver salts, or in the later stages of the development, fixing, etc., of the picture undesirable reactions may take place. The gelatin solution must be made such that the dried film will have just the right degree of porosity to electrolytes, for in all stages of the development where chemicals are used it is necessary that they penetrate and impregnate the gelatin layer with considerable ease, but no trace of the precipitated silver must be permitted to escape. It is indeed due to the protective action of the gelatin that the precipi-

tated silver remains finely divided as an even thin deposit. Other colloids, on account of their inferior protective action, are less adapted to this service and cannot advantageously be substituted for gelatin.

When a gelatin solution is treated with a solution of a soluble bichromate and, after setting, exposed to the action of strong light, the gel becomes insoluble. This reaction has been applied with success to the process of *photolithography*. Gelatin which has been treated with the bichromate in the dark and allowed to form a jelly on a glass plate is exposed, through a photographic negative to a strong light. That portion of the gelatin plate which receives light through the negative will be rendered insoluble, and later, when placed in water will not swell to the same extent as the parts which were protected from the light by the deposit of the negative. Furthermore, the amount of swelling which any part of the plate will undergo is in exact inverse proportion to the amount of light which penetrates the negative to it. The picture is thus reproduced upon the gelatin plate. This plate may then be covered with graphite and a plate of copper deposited upon it in an electrolytic solution, in which case the copper plate, backed with easily fusible metal poured upon it, may be inserted in the printing press and prints made. In one form or another the process has been in use for a great many years.

The first study of importance upon the reactions involved upon the addition of a soluble bichromate to gelatin, and the subsequent exposure to light was made by Eder<sup>1</sup> in 1878. He succeeded in demonstrating that light exerted a reducing action upon the bichromate in the presence of gelatin with the formation of chromium sesquioxide. This in turn reacted with any excess of bichromate forming chromium chromate which likewise decomposed under the prolonged action of light until it was eventually completely transformed into sesquioxide. Lumière and Seyewetz<sup>2</sup> have in a number of later communications confirmed the findings of Eder and added to them in making exact determinations of the several variable influences in the operation, and in showing that the reaction produces a product of a perfectly definite composition.

<sup>1</sup> EDER, *Compt. rend.* (1878).

<sup>2</sup> A. LUMIÈRE and A. SEYEWETZ, *Bull. Soc. chim.*, **29** (1903), 1077; 1085; **33** (1905), 1032, 1040.

The reactions involved are written by them as follows:

The bichromate is first reduced by the action of the gelatin and light, forming the sesquioxide of chromium,

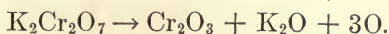

The oxygen is absorbed by the gelatin, participating in its insolubilization. The potassium oxide is, of course, changed to the hydroxide and reacts with more of the bichromate with the formation of chromate,

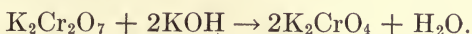

The neutral chromate acts on the gelatin in the presence of light in a manner quite similar to that of the bichromate but with extreme slowness,

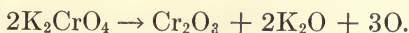

Finally the sesquioxide reacts with the excess of bichromate to form chromium chromate,



It is probable that the latter equation might better be written,

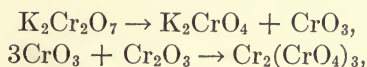

and if Eder's observation that this also goes slowly to the sesquioxide is correct, the final equation may be added,

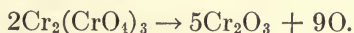

Lumière and Seyewetz found also that the amount of  $\text{Cr}_2\text{O}_3$  fixed per unit weight of gelatin increased with the amount of bichromate added, and that the proportion of added bichromate that actually entered into the reaction increased with the duration of the exposure to light. Upon studying the action of the bichromates of eleven different metals, including chromic acid, they found that the susceptibility to reduction, and the consequent insolubilization of the gelatin, varied greatly, the bichromate of iron having the least effect, and that of ammonium the greatest. In fact the quantity of chromium sesquioxide obtained by the use of ammonium bichromate was nearly twice that resulting from the use of the potassium salt during equal exposures.

In the light of more modern theory it seems probable that chromium gelatinat is formed. The chromium is trivalent, and Loeb<sup>1</sup> has shown, using aluminum and cerium salts, that the

<sup>1</sup> J. LOEB, *J. Gen. Physiol.*, **1** (1918-19), 483.

several properties of gelatin, including solubility, swelling, viscosity, etc., are depressed in proportion to the increasing valence of the cation added. Thus the divalent calcium ion, forming calcium gelatinate, results in a product having lower solubility, swelling, etc., than the monovalent sodium ion of sodium gelatinate, while the trivalent aluminum ion, forming aluminum gelatinate, produces a product even more insoluble. If his generalization is correct, then chromium gelatinate should also be insoluble, as seems to be the case. The greater efficiency obtained by adding the bichromate and allowing this to be reduced to the chromate obviously results in an increase in the amount of available  $\text{Cr}_2\text{O}_3$  for the reaction, and it is doubtful if the oxygen liberated as such assumes an important rôle in the insolubilization of the material. When chromic acid alone is used it is probable that the product formed is largely gelatin chromate, but this being a dibasic acid, and the pH of the mixture probably being brought very close to the isoelectric point, a certain degree of insolubility would undoubtedly arise.

A thorough study of the action of the chromates and bichromates upon gelatin from the standpoint of modern theory and under rigid control of hydrogen ion concentration should be highly fruitful of a better understanding of these reactions.

**2. Gelatin as a Bacterial Culture Medium.**—Koch first employed gelatin as a solid medium for studying the behavior of bacteria and other microorganisms, and it has since become one of the standard media for this purpose. It possesses the advantage over many other substances in favoring the development of a large variety of species, but often suffers the disadvantage of becoming liquefied by the organisms.

Nutrient gelatin may be prepared by adding about 3 grams of beef and 5 grams of peptone to a liter of distilled water, and adding 100 grams of gelatin. After the gelatin has swollen for an hour or so the mixture is warmed until a solution is obtained. The medium is made neutral or slightly alkaline to phenolphthalein, filtered, distributed in tubes, and sterilized by heating in an autoclave at 15 pounds pressure ( $120^\circ\text{C}.$ ) for 15 minutes, or by intermittent heating at  $100^\circ$  for 30 minutes on three successive days. The white of an egg dissolved in 30 to 60 c.c. of distilled water may be beaten in to improve the clarity of the solution. Mixtures of gelatin with other media are often made for special purposes. Among such mixtures may be mentioned



agar gelatin, wort gelatin, whey gelatin, soil extract gelatin, litmus gelatin, raisin gelatin, and Hiss Medium.

In determining the power of microorganisms to liquefy gelatin, straight needle stab cultures are made in gelatin tubes, and the latter incubated at 20°C. The Society of American Bacteriologists in 1907 recommended that gelatin tubes be held for 6 weeks to determine liquefaction. Some cultures, however, will liquefy gelatin only after several months,<sup>1</sup> while others will require but a day. Rothberg<sup>2</sup> proposes to obviate this difficulty by giving the organism a preliminary cultivation in a 1 per cent gelatin solution at 25 or 37°C., then inoculate the surface of gelatin in a test tube and incubate for 15 days at 20°.

**3. Gelatin Cells for Ultrafiltration.**—For the ultrafiltration of suspensoid colloids membranes made from gelatin or collodion are often used. They may very easily be prepared<sup>3</sup> by impregnating disks of a hard filter paper with a solution of the gelatin. Care must be taken not to entrap any air bubbles underneath the paper, and to have the paper uniformly penetrated with the sol. A 2 to 10 per cent sol of gelatin may be used, and the containing disk should be kept on the water bath *at a definite temperature* during impregnation. Especial care must be exercised in this point, because the porosity of the filter will vary with the temperature as well as with the concentration. For uniform results in any one experiment, therefore, the temperature and concentration must be held rigidly constant. After removing the disks from the liquid they are allowed to drain, turning constantly in their own plane to prevent an excess of gel forming on the under side. After the gel has set, the papers are placed in a 2 to 4 per cent solution of formaldehyde for 24 hours to render insoluble, the whole being placed in the cooler during this time. The disks are then rinsed in cold water and may be kept in water saturated with chloroform. If they are allowed to dry, even partially, they become useless. The common forms of fat extraction thimble may also be used to advantage in many cases for the preparation of ultrafilters.

If experiments calling for varying gradations in the size of pore, or particle which will be allowed to pass through, are

<sup>1</sup> F. W. TANNER, "Bacteriology and Mycology of Foods" (1919), 111.

<sup>2</sup> W. ROTHBERG, Paper read before Soc. Am. Bacteriologists (1917).

<sup>3</sup> E. HATSCHKE, "Laboratory Manual of Colloid Chemistry," Philadelphia (1920), 69.

designated, filters may be made up as above using several different concentrations of gelatin between 2 and 10 per cent at the same temperature. Much more concordant results are obtained by this procedure than by varying the temperature of a specified concentration.

**4. Gelatin in Analytical Procedures.**—On account of the difficulty of filtering and otherwise handling analytically solutions that contain even traces of gelatin or glue, these substances are commonly regarded as altogether impermissible in such solutions, and if present must be eliminated. The very properties, however, that make them usually undesirable may in certain instances be utilized in a determination. Grete<sup>1</sup> has based a volumetric estimation of phosphorus as phosphate upon the particular type of precipitation he is able to obtain with molybdate solutions in the presence of gelatin. He finds that "an addition of gelatin, or similar substance as peptone, results in a precipitate of phosphomolybdate that is whitish and voluminous, such that a very small amount of phosphoric anhydride, *e.g.*, 0.000125 g., will reveal itself as a distinct cloud in the clear liquid. By a short warming the gelatin separates from the phosphomolybdate and the precipitate assumes the usual yellow compact form and settles readily and quickly. Upon a further addition of a little molybdic acid solution, so long as any phosphoric acid remains, a voluminous gelatin-containing precipitate will again come down. It is possible by this means, through continued additions of molybdic acid and subsequent heating and settling of the precipitate to titrate to a sharp end point." The gelatin was added to the slightly alkaline solution of the molybdate, and this run into the solution of the phosphate containing definite amounts of ammonium nitrate and nitric acid until, after boiling, further additions produced no precipitate. The solutions are standardized by means of pure di-hydrogen potassium phosphate, and the effect due to the acidity is determined for each set of solutions. Grete reports that he has performed over 100,000 analyses by this method with entire satisfaction.

**5. Gelatin as a Medium for Demonstrating Colloidal Phenomena.**—Gelatin has ever been held in the highest regard as an ideal medium for demonstrating the many phenomena incident to the behavior of and the study of colloids. The very name "colloid" was given to that class of substances by Graham in

<sup>1</sup> A. GRETE, *Ber.*, **21** (1888), 2762; **32** (1909), 3106.

1861 on account of the similarity which they bore to gelatin (colloid from *colla*, glue). The two great discoveries of Graham which definitely established colloid chemistry as distinguished from the chemistry of molecularly dispersed systems were concerned with gelatin. The first of these distinguished between the diffusibility of gelatin, glue, gum-arabic, etc., and ordinary crystalloids, while the second had to do with the obtaining in a state of an apparently homogeneous solution substances that were ordinarily considered as insoluble. The protective action of gelatin was here, in some cases, utilized.

All of the colloid chemists since the day of Graham have likewise found gelatin of the greatest value in the study of colloids, and in the demonstration of special colloidal properties. Lупpo-Cramer<sup>1</sup> has very successfully demonstrated the differences in the color of metallic suspensoids with differences in degree of dispersion by dispersing the solutions in plates of gelatin. For example, he obtained photographic plates of silver dispersed in gelatin that were yellow, orange, red, violet, blue, and green. In the solutions of highest dispersion the metals are usually yellow or orange. In other words they absorb the violet and blue light. As the size of the particle becomes greater the color passes from yellow and orange to red, violet, blue, and finally green. "The absorption maximum gradually moves towards the side of the greater wave lengths as the degree of dispersion decreases."<sup>2</sup> Similar preparations demonstrating the color change in gold and platinum with degree of dispersion may easily be made.

The laws of the viscosity of emulsoids have been studied, using gelatin as the type, by Hatschek,<sup>3</sup> Pauli,<sup>4</sup> Wo. Ostwald,<sup>5</sup> and many others. The ionization of proteins and of colloids has been concentrated upon gelatin by Loeb,<sup>6</sup> Fischer,<sup>7</sup> Bogue<sup>8</sup> and others. The phenomenon of the Liesegang ring formation is obtained in gelatin more easily than in most other colloid gels. The enor-

<sup>1</sup> LUPPO-CRAMER, *Kolloid-Z.*, **8** (1911), 240.

<sup>2</sup> WO. OSTWALD, *Kolloidchem. Beihefte*, **2** (1911), 409.

<sup>3</sup> E. HATSCHEK, *Kolloid-Z.*, **7** (1910), 301; **8** (1911), 34; *Trans. Faraday Soc.*, **9** (1913), 80.

<sup>4</sup> WO. PAULI, *Trans. Faraday Soc.*, **9** (1913), 54.

<sup>5</sup> WO. OSTWALD, *ibid.*, **9** (1913), 34.

<sup>6</sup> J. LOEB, *J. Gen. Physiol.*, vols. 1, 2, 3.

<sup>7</sup> MARTIN FISCHER, *J. Am. Chem. Soc.*, **40** (1918), 272; 303.

<sup>8</sup> R. H. BOGUE, *J. Am. Chem. Soc.*, **44** (1922), 1313; 1343.

mous water absorption and swelling of hydrophile colloids is beautifully illustrated by gelatin. The protective action of the emulsoid colloids is better shown by gelatin, as revealed by its gold number, than by any other colloid.

Gelatin is indeed the type hydrophile or emulsoid colloid, and whenever, either for new investigational research or for demonstrational purposes, it is desired to study the properties of the type, gelatin is most conveniently and satisfactorily employed.



## APPENDIX

	PAGE
1. Hydrogen Ion Concentration and pH.....	579
Ionization Equilibria.....	579
The Theory of the Hydrogen Electrode.....	583
The Electrometric Determination.....	587
The Theory of Indicators and the Colorimetric Determination..	599
2. Ionization Constants of Acids and Bases.....	606
3. The Conversion of MacMichael Viscosity Degrees to Centipoises..	608
4. Specific Gravity in Degrees Baumé and Twaddell.....	611
5. Comparison of Centigrade and Fahrenheit Scales.....	614
6. Conversion of Parts per Million to Grains per United States and Imperial Gallons and to Per Cent.....	614
7. Metric and American Equivalents.....	615
8. Specific Gravity and Percentage Composition of Hydrochloric, Nitric, and Sulphuric Acids, and Sodium, Potassium and Am- monium Hydroxide Solutions.....	616
9. Table for the Conversion of Volume of Nitrogen to Milligrams....	621
10. The Chemical Elements and their Atomic Weights.....	622
11. Logarithms of Numbers.....	623

### 1. HYDROGEN ION CONCENTRATION AND pH

**Ionization Equilibria.**—All acids and acidic substances are characterized by the fact that they dissociate to a greater or lesser extent in aqueous solution into ions, among which are included the ions of hydrogen, while bases and basic substances dissociate with the formation of hydroxyl ions. In the case of amphoteric substances which may liberate both hydrogen and hydroxyl ions, they are said to be acid or alkaline according to the predominance of the hydrogen or the hydroxyl ions respectively.

The variation in the relative proportion of hydrogen and hydroxyl ion concentration in any case is due to the fact that these two ions combine to form water, and that the ionization of water at any given temperature is a constant value. These relations are expressed by the Mass Law of Guldberg and Waage, according to the equation:

$$\frac{[\text{H}^+] \times [\text{OH}^-]}{[\text{H}_2\text{O}]} = k,$$

in which the brackets signify ionic or molecular concentrations,

and  $k$  is a constant. Since the ionization of water is very slight, the concentration of the undissociated water  $[H_2O]$  will always be practically constant, so the equation may be written:

$$[H^+] \times [OH^-] = K_w,$$

in which  $K_w$  is known as the ionization constant for pure water. Now since the above equation is an expression of fact, it follows that if there exists in any solution an excess of hydrogen ions, then, in order that  $K_w$  shall not change, the concentration of hydroxyl ions must become smaller. This is brought about by the combination of the hydroxyl ions with some of the excess hydrogen ions until the product of the concentrations of the two is again that represented by  $K_w$ . On the other hand, if an excess of hydroxyl ions is present or caused to be formed in the solution, a similar combination reduces the concentration of the hydrogen ions to that necessary in order that the product shall be equal to  $K_w$ . In case neither of these ions are present in excess the concentrations of the two will be equal, and the solution is spoken of as neutral. This is the condition in pure water, and in such solutions as do not result in any change in this equilibrium.

The value of  $K_w$  in pure water has been investigated by a number of workers and a number of different methods have been employed for the determination. The very careful researches of Michaelis<sup>1</sup> gave it the value of  $10^{-14}$  at  $22^\circ C$ . Since in pure water  $[H^+]$  must be equal to  $[OH^-]$ , it follows that the value for each of these is, in water,  $10^{-7}$  at  $22^\circ C$ .<sup>2</sup> As the temperature changes, the ionization constant also changes, becoming greater as the temperature rises. A table illustrative of this is given on page 593. But when one of these ions is increased, as by the addition of an acid, the other ion must be repressed to such an extent that the product of the concentrations of the two shall be always  $10^{-14}$  (at  $22^\circ C$ ). For example, in a normal solution of a completely dissociated acid the ionic concentration of the hydrogen ion is 1. The concentration of the hydroxyl ion is then:

$$[OH^-] = K_w / [H^+],$$

<sup>1</sup> MICHAELIS, "Die Wasserstoffionenkonzentration," (1914).

<sup>2</sup> The findings of  $[H^+]$  in water by other investigators has varied from  $15.8 \times 10^{-7}$  to  $1.23 \times 10^{-8}$ . Cf. Beans and Oakes, *J. Am. Chem. Soc.*, **42** (1920), 2116.

or  $10^{-14}/10^0 = 10^{-14}$ . If the solution is N/100 acid,  $[H^+] = 1/100$  or  $10^{-2}$ , and  $[OH^-] = 10^{-14}/10^{-2} = 10^{-12}$ . Obviously the sum of the exponents of 10, representing the concentrations of the two ions must always be  $-14$ . If the concentrations were expressed in whole numbers, the hydroxyl ion would have the value, in the latter case, of N/1,000,000,000,000, which is the same as writing  $[OH^-] = 10^{-12}$ . In water  $[H^+]$  and  $[OH^-]$  are both N/10,000,000, but this value is more easily expressed as  $10^{-7}$ .

The system of expressing the hydrogen ion concentration as exponents of 10 does not seem cumbersome so long as only integers are necessary, but as soon as decimals are required they become less easy of interpretation. The electrometric measurement of the value is found to involve the expression:

$$\frac{\text{Potential}}{\text{Numerical factor}} = \log \frac{1}{[H^+]},$$

and Sørensen<sup>1</sup> in 1909 suggested that the term " $\log \frac{1}{[H^+]}$ " be denoted by the symbol pH and employed without further change for expressing the hydrogen ion concentration. This suggestion has many obvious advantages and has been almost universally adopted by chemists, physicists and biologists. The pH is a linear function of the hydrogen electrode potential and the errors in determination are proportional to pH rather than to  $[H^+]$ . It is at first confusing that the pH varies inversely as  $[H^+]$ , but if we remember that pH indicates the hydroxyl as well as the hydrogen ion concentration this apparent conflict with a mental habit is at once overcome.

If  $[H^+]$  is desired to be calculated from a known pH, it may be done without trouble. For example, if  $\text{pH} = 8.52$ ,  $C_H = 10^{-8.52} = 10^{-9 + 0.48} = 10^{0.48} \times 10^{-9}$ .  $10^{0.48} = 3.02$  (antilog of 0.48). Therefore pH 8.52 is equivalent to  $[H^+] = 3.02 \times 10^{-9}\text{N}$ . If we have given the latter value, to find the pH,  $\text{pH} = \log \frac{1}{3.02 \times 10^{-9}} = 1 - \log (3.02 \times 10^{-9})$ .  $\log 1 = 0$ , So  $\text{pH} = -\log 3.02 - \log 10^{-9}$ ,  $= -0.48 + 9.00 = 8.52$ .

The general relationship between pH and hydrogen ion concentration is shown in Table 66. The normality of the solution may be correctly said to be identical with the hydrogen ion con-

<sup>1</sup> S. SØRENSEN, *Comp. rend. Lab. Carlsberg*, 8 (1909), 1.

TABLE 66.—APPROXIMATE RELATION OF  $[H^+]$  AND  $[OH^-]$  TO pH AND NORMALITY

Normality <sup>1</sup>	pH	$[H^+]$	$[OH^-]$
N HCl.....	0.0	1.0	$10^{-14}$
0.1 HCl.....	1.0	0.1	$10^{-13}$
0.01 HCl.....	2.0	$10^{-2}$	$10^{-12}$
0.001 HCl.....	3.0	$10^{-3}$	$10^{-11}$
0.0001 HCl.....	4.0	$10^{-4}$	$10^{-10}$
0.00001 HCl.....	5.0	$10^{-5}$	$10^{-9}$
0.000001 HCl.....	6.0	$10^{-6}$	$10^{-8}$
Neutrality.....	7.0	$10^{-7}$	$10^{-7}$
0.000001 KOH.....	8.0	$10^{-8}$	$10^{-6}$
0.00001 KOH.....	9.0	$10^{-9}$	$10^{-5}$
0.0001 KOH.....	10.0	$10^{-10}$	$10^{-4}$
0.001 KOH.....	11.0	$10^{-11}$	$10^{-3}$
0.01 KOH.....	12.0	$10^{-12}$	$10^{-2}$
0.1 KOH.....	13.0	$10^{-13}$	$10^{-1}$
N KOH.....	14.0	$10^{-14}$	1.0

TABLE 67.— $[H^+]$  AND pH OF SOME ACIDS AND ALKALIES<sup>2</sup>

Ionogen	Normality	$[H^+]$	pH
HCl.....	1.0	$8.0 \times 10^{-1}$	0.10
HCl.....	0.1	$8.4 \times 10^{-2}$	1.071
HCl.....	0.01	$9.5 \times 10^{-3}$	2.022
HCl.....	0.001	$9.7 \times 10^{-4}$	3.013
HCl.....	0.0001	$9.8 \times 10^{-5}$	4.009
CH <sub>3</sub> COOH.....	1.0	$4.3 \times 10^{-3}$	2.366
CH <sub>3</sub> COOH.....	0.1	$1.36 \times 10^{-3}$	2.866
CH <sub>3</sub> COOH.....	0.01	$4.3 \times 10^{-4}$	3.366
CH <sub>3</sub> COOH.....	0.001	$1.36 \times 10^{-4}$	3.866
NaOH.....	1.0	$0.90 \times 10^{-14}$	14.05
NaOH.....	0.1	$0.86 \times 10^{-13}$	13.07
NaOH.....	0.01	$0.76 \times 10^{-12}$	12.12
NaOH.....	0.001	$0.74 \times 10^{-11}$	11.13
NH <sub>4</sub> OH.....	1.0	$1.7 \times 10^{-12}$	11.77
NH <sub>4</sub> OH.....	0.1	$5.4 \times 10^{-12}$	11.27
NH <sub>4</sub> OH.....	0.01	$1.7 \times 10^{-11}$	10.77
NH <sub>4</sub> OH.....	0.001	$5.4 \times 10^{-10}$	10.27

<sup>1</sup> Theoretical value assuming complete dissociation. See next table.<sup>2</sup> MICHAELIS, "Die Wasserstoffionkonzentration" (1914), 23.



centration only when 100 per cent dissociated, but for the fixing of the approximate relationship in the mind a few normality expressions are included. In Table 67 are shown the pH and hydrogen ion concentration of some acids and alkalies that have been experimentally determined. As shown, the weaker the electrolyte, *i.e.*, the less the dissociation,—the further removed will be the pH from the assigned normality value. The conversion of pH to  $[H^+]$  is shown in Table 68.

TABLE 68.—CONVERSION TABLE OF pH TO  $[H^+]$ <sup>1</sup>

pH	$[H^+]$	pH	$[H^+]$
0.00	$1.00 \times 10^{-2}$	0.55	$0.28 \times 10^{-2}$
0.05	$0.89 \times 10^{-2}$	0.60	$0.25 \times 10^{-2}$
0.10	$0.79 \times 10^{-2}$	0.65	$0.22 \times 10^{-2}$
0.15	$0.71 \times 10^{-2}$	0.70	$0.20 \times 10^{-2}$
0.20	$0.63 \times 10^{-2}$	0.75	$0.18 \times 10^{-2}$
0.25	$0.56 \times 10^{-2}$	0.80	$0.16 \times 10^{-2}$
0.30	$0.50 \times 10^{-2}$	0.85	$0.14 \times 10^{-2}$
0.35	$0.45 \times 10^{-2}$	0.90	$0.13 \times 10^{-2}$
0.40	$0.40 \times 10^{-2}$	0.95	$0.11 \times 10^{-2}$
0.45	$0.36 \times 10^{-2}$	1.00	$0.10 \times 10^{-2}$
0.50	$0.32 \times 10^{-2}$	....	.....

Example pH = 7.00;  $[H^+] = 1 \times 10^{-7}$

pH = 7.60;  $[H^+] = 0.25 \times 10^{-7}$  or  $2.5 \times 10^{-8}$

**The Theory of the Hydrogen Electrode.**—Nernst<sup>2</sup> has produced an equation by which the exact relations obtaining between the electrode potential of a solution and the ionic concentration are defined. This is based upon the conception of electrolytic solution tension, *i.e.*, the difference in potential developed between a metal and a solution of that metal when the two are brought together. A tendency either for the metal to go into solution, or for the metallic ions to come out of solution is manifested by the development of a measurable potential between the two phases. The thermodynamic soundness of the principle has since been many times demonstrated.

The fundamental equation may be written:

$$E = \frac{RT}{nF} \ln \frac{C}{C'}$$

<sup>1</sup> W. M. CLARK, "The Determination of Hydrogen Ions" (1920), 307.

<sup>2</sup> W. NERNST, *Z. physik. Chem.*, 4 (1889), 129.

where  $E_{12}$  the electromotive force measured (the algebraic sum of the two electrode potentials of the two half cells),  $R$  is the gas constant (8.3129446 joules per degree),  $T$  is the absolute temperature ( $C. + 273$ ),  $n$  is the valence of the ion ( $H = 1$ ),  $F$  is the Faraday constant (96,494 coulombs),  $\ln$  refers to the natural logarithm, and  $C$  and  $C'$ , are the ionic concentrations of the two solutions. On substituting the constants in the equation and transposing to Briggsian logarithms (to the base 10) by dividing by 0.43429, and referring to a solution normal with respect to the hydrogen ion, we obtain:

$$E = 0.00019837T \log \frac{1}{C}$$

Since, however, it has been found difficult to obtain a solution absolutely standard with respect to hydrogen ion it has become customary to employ for our working standard a calomel electrode and to calculate the difference of potential between this arbitrary standard and the theoretical normal hydrogen electrode by measurements made against a solution of some fractional normal hydrogen ion concentration. Such measurements have been made with great care using tenth normal, normal, and saturated potassium chloride—calomel electrodes. The most generally accepted values are shown below.

TABLE 69.—STANDARD VALUES FOR CALOMEL ELECTRODES<sup>1</sup>

Temperature, °C.	Concentration of KCl		
	M/10	M/1	Saturated
18	0.3380	0.2864	0.2506
20	0.3379	0.2860	0.2492
25	0.3376	0.2848	0.2464
30	0.3373	0.2837	0.2437
40	0.3360	.....	.....

The working formula, therefore, becomes:

$$\frac{E. M. F. (\text{observed}) - e (\text{calomel electrode})}{0.00019837 T} = \log \frac{1}{[H^+]} = \text{pH.}$$

<sup>1</sup> W. M. CLARK, *lib. cit.*, 306.

Thus, by working with an N/10 calomel cell at a temperature of 25°C., the formula becomes:

$$\text{pH} = \frac{E - 0.3376}{0.05911};$$

or at 30° with a normal cell:

$$\text{pH} = \frac{E - 0.2837}{0.06011},$$

$E$  in these cases representing the observed electromotive force.

*Influence of Barometric Pressure, and Dilution.*—Hydrogen ion concentrations are usually based upon the hydrogen pressure of one atmosphere or 760 millimeters of mercury. A measurement made at any other pressure will produce an error which should be corrected in exact physico-chemical researches, but the size of the correction is so small that it may be safely disregarded in all but the most exacting investigations. Loomis and Acree<sup>1</sup> found that a difference of 40 millimeters in the barometric pressure produced a change of only 0.0007 volt in the E. M. F. The correction may be applied by the formula:

$$E_o = E_b \pm \frac{0.00019837T}{2} \log \frac{760}{b},$$

where  $E_o$  is the corrected E. M. F. at 760 mm., and  $E_b$  is the E. M. F. at a barometric pressure  $b$ . The factor is added when  $b$  is less, and subtracted when  $b$  is greater than 760 millimeters.

The influence of dilution on the hydrogen ion concentration of a liquid or solution varies greatly with the nature of the substance in question. If a pure strong inorganic acid, as hydrochloric, is diluted, the pH follows very closely the normality of the solution. That is, a dilution of 1 to 10, as from 0.1 to 0.01N, produces almost the theoretical change in  $[\text{H}^+]$  and pH that would be expected, *i.e.*, from 1.07 to 2.02. This slight discrepancy is adequately accounted for by the increasing dissociation upon dilution. A further dilution to 0.001N brings the pH to 3.01 and to 0.0001N to 4.01 which is almost exactly coincident with the theoretical values. Strong bases behave in an entirely similar manner.

If a weak acid such as acetic is used, the change in pH upon dilution will be smaller. The pH of a 0.1N solution is in this case 2.87, which is quite far removed from the value 1.00 which would be the value in a completely dissociated acid, and on dilut-

<sup>1</sup> N. E. LOOMIS and S. F. ACREE, *J. Am. Chem. Soc.*, **38** (1916), 2391.

ing to 0.01N the change is only to 3.37, or half the change that would result in the strong acids. In still weaker acids the change in pH upon dilution becomes very small. The following table shows the effect of dilution upon the pH of glycine and asparagine.<sup>1</sup>

TABLE 70.—CHANGE IN pH UPON DILUTION

Glycine	pH	Asparagine	pH
1.0 M.....	6.089	1.0 M.....	2.954
0.1 M.....	6.096	0.1 M.....	2.973
0.01 M.....	6.155	0.01 M.....	3.110
0.001 M.....	6.413	0.001 M.....	3.521
0.0001 M.....	6.782	0.0001 M.....	4.166

The addition of a salt with a common ion to a solution of a weak acid is shown by the Mass Law to result in a decrease in the hydrogen ion concentration. For example, the ionization equilibrium for acetic acid is:

$$\frac{[\text{H}^+] \times [\text{CH}_3\text{COO}^-]}{[\text{CH}_3\text{COOH}]} = K.$$

If to this system sodium acetate is added, which is largely dissociated into the ions  $\text{Na}^+$  and  $\text{CH}_3\text{COO}^-$ , the concentration of the  $\text{CH}_3\text{COO}^-$  ions in the system is greatly increased. In order that  $K$  shall remain constant under these new conditions hydrogen ions must combine with some of the excess acetate ions forming the undissociated acid until  $K$  has again reached its former value. That is,  $[\text{H}^+]$  is greatly suppressed and accordingly the pH will become greater.

If now such a system be diluted with pure water there will be very little further alteration in pH, because the equilibrium has become one dependent to a far greater extent upon the relative concentrations of salt to acid, than upon acid to water. Dilution will not alter the former ratio except in so far as it results in an increase in the dissociation of the acid. Walpole<sup>2</sup> has found that the change of pH resulting from a twenty-fold dilution of an acetic acid—sodium acetate mixture, when present in approximately equivalent proportions, is about 0.08 pH.

<sup>1</sup> S. SØRENSEN, *Compt. rend. trav. lab. Carlsberg*, **12** (1917), 1.

<sup>2</sup> G. S. WALPOLE, *J. Chem. Soc.*, **105** (1914), 2501; 2521.



*Buffer Action.*—One of the difficulties in obtaining exact measurements of the pH of pure water lies in the extreme sensitivity of water to minute traces of impurities, such as carbon dioxide or other gases that may be dissolved in it. If 1 c.c. of 0.01N hydrochloric acid is added to a liter of pure water the pH will be altered from 7.0 to 5.0, *i.e.*, a hundred-fold increase in  $[H^+]$ . But if the same amount of acid is added to a liter of a gelatin solution at pH 7.0, the change in pH would be hardly appreciable. This power of certain substances to resist the change in  $[H^+]$  upon the addition of reagents which in pure water would produce a profound alteration has been spoken of by Sørensen<sup>1</sup> as due to a *buffer action* of the material. This term has been very generally taken up in reference to any solution which resists alteration in pH due to the addition or loss of acid or alkali. Colorimetric methods for the measurement of hydrogen ion concentration all make use of solutions of standard pH values which are made from well buffered mixtures that they may remain constant and that serious errors may not be introduced through slight dilution.

**The Electrometric Determination.**—The equipment necessary for the carrying out of electrometric measurements of pH includes the following: A *hydrogen electrode* consists of a strip of platinum (palladium, iridium or gold are sometimes used) which may be in the form of a flat foil, or as a gauze, or spiral. This is coated with a layer of platinum black (or of palladium or iridium black) by electrolysis in a 1 per cent solution of pure chlorplatinic acid,<sup>2</sup> or in a 1 to 3 per cent hydrochloric acid solution of platinum chloride.<sup>3</sup> The current may be supplied from a 4 volt storage battery, and should be reversed every 2 or 3 minutes. The layer should not be made too thick, about ten minutes being a sufficient time to allow for the deposition. This coated electrode is then sealed into a glass tube, the exact form of which has been largely determined by the particular requirements of the problem in hand. A large number of types have been discussed in the literature.

The *hydrogen electrode vessel* contains the solution under investigation and into this is dipped the hydrogen electrode. The arrangement must provide for the alternate exposure of the

<sup>1</sup> S. SØRENSEN, *loc. cit.*

<sup>2</sup> J. H. ELLIS, *J. Am. Chem. Soc.*, **38** (1916), 737.

<sup>3</sup> W. M. CLARK, *lib. cit.*, **124**.

electrode to a stream of hydrogen gas and to the solution in the vessel. This is often accomplished by requiring the gas to bubble past the electrode in its passage into the solution. Clark uses a vessel that may be rocked. A few types of hydrogen cells are shown in the accompanying illustrations.

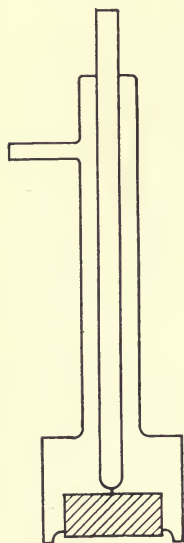

FIG. 109.—The hydrogen electrode of J. H. Hildebrand.

The *standard half cell* is usually a *calomel electrode* but Acree has proposed a hydrogen electrode bathed in a standard buffer solution for this purpose. The calomel cells are made by placing a little highly purified mercury in the bottom of the cell, over this placing a layer of pure calomel, and finally a solution of potassium chloride of a definite concentration. Custom has placed the concentration of the latter solution at either 0.1N, 1.0N, or saturated.

The calomel should be prepared as follows: purified mercury is dissolved in redistilled nitric acid, and the solution poured into a large excess of distilled water. A redistilled 20 per cent solution of hydrochloric acid is diluted and added slowly and with constant stirring to the above. When the precipitate has settled the liquid is decanted off, and the residue washed by decantation with distilled water for several days. Potassium chloride solution of the strength desired, made from recrystallized highest purity salt, is then substituted for the water and many more washings made.

A *potentiometer* is the most satisfactory instrument for making E. M. F. measurements, although a millivoltmeter has been used in several important researches. The type K potentiometer of the Leeds and Northrup Company, shown in Figs. 113 and 114, is the best instrument now available. A less expensive form known as the Northrup pH Pyrovolter Potentiometer<sup>1</sup> is more compact and convenient for carrying about as the instrument requires no storage battery, standard cell, or galvanometer. As accessories to the former instrument, there are required a two volt storage cell, a Weston standard cadmium cell, and a galvanometer. The type R reflecting galvanometer with a lamp and scale outfit,

<sup>1</sup> Graham Chemical Co., Rochester, N. Y.

and provided with a heavy damping resistance, are desirable for the most accurate work, but the box-type enclosed lamp and scale galvanometer is satisfactory for all work of moderate precision. The Lippman electrometer has in the past served as the measure of current adjustment, but the much more easily handled galvanometers have almost completely superseded that delicate but troublesome instrument.

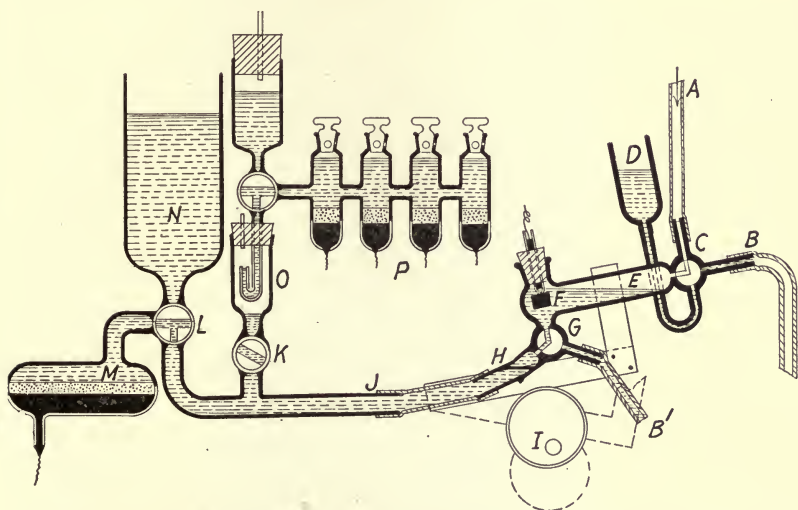

FIG. 110.—Clark's system for the determination of hydrogen ions. (From W. M. Clark, "The Determination of Hydrogen Ions," Williams and Wilkins Company, Baltimore, 1920.)

The *hydrogen gas* is most conveniently supplied from a cylinder of the compressed gas, supplied with a reducing valve, and purified by passing through solutions of alkaline permanganate, concentrated sulphuric acid, and finally water containing a little barium chloride. The water leaves the gas moist so that it will not produce evaporation of the solution being measured upon being passed through it, while the barium chloride removes any traces of sulphuric acid that may be carried over. The use of hydrogen from commercial tanks, after proper purification, has been employed successfully by a number of investigators. If it is desired to generate the gas it may be done by the electrolysis of water or dilute sodium hydroxide.<sup>1</sup> The action of acids on metals is less satisfactory.

<sup>1</sup> Cf. W. M. CLARK, *lib. cit.*, 162.

An *air thermostat* for maintaining a constant temperature should be used as a container for the hydrogen and calomel cells if the highest accuracy is required, but for most work it will be unnecessary to take this precaution provided the temperature of the measurements is noted and the formula corrected accordingly.

*The Measurement.*—The connections are made upon the

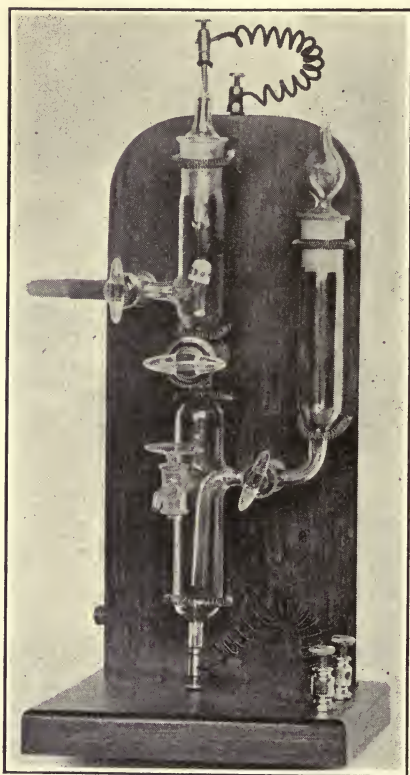

FIG. 111.—The Elliott single cell "Ion-O-Meter." (Kindness of Felix A. Elliott.)

potentiometer as indicated,<sup>1</sup> using care always to connect + to +, and attaching the + E. M. F. wire to the calomel electrode and the - wire to the hydrogen cell. The solution to be tested, which should not be too viscous, is placed in the hydrogen electrode vessel and hydrogen admitted as described, adopting what-

<sup>1</sup> For details of wiring and measurement see Leeds and Northrup catalogue No. 70 (1919), or W. M. CLARK, *lib. cit.*, 142.



ever means that may be necessary to insure the proper shaking or stirring of the solution. After the hydrogen has been passing for a suitable length of time (about 10 to 15 minutes in the Clark cell, or 30 minutes in the Hildebrand type), the supply of gas is shut off, the shaking stopped, and liquid connection made

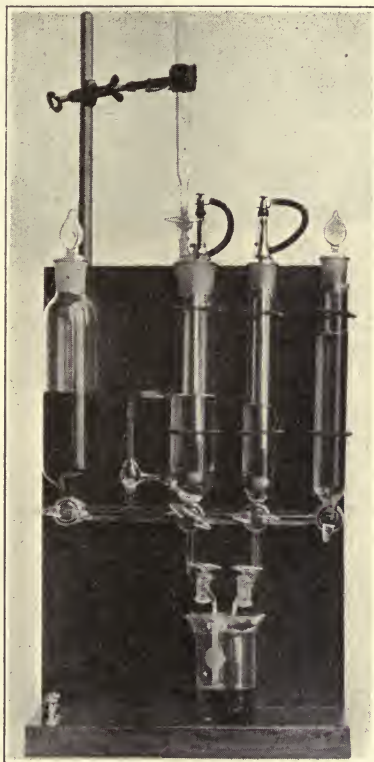

FIG. 112.—The Elliott titration "Ion-O-Meter." (*Kindness of Felix A. Elliott.*)

between the hydrogen electrode vessel and the saturated potassium chloride, obtaining as large a contact surface between the two solutions as practicable in order to reduce the contact potential to a minimum. A liquid contact is also made between the calomel electrode and the saturated potassium chloride solution. The potential of the storage battery is adjusted against that of the standard cell by varying the resistance in the rheostat of the potentiometer until the two are identical as indicated by a zero deflection of the galvanometer upon making the connection.

The connection with the calomel and hydrogen cells is then made, and the deflection again brought to zero by varying the resistance

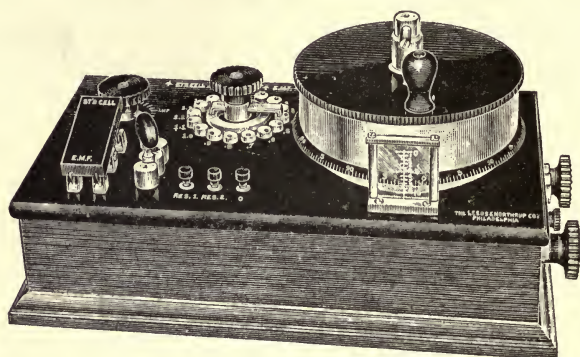

FIG. 113.—The Leeds and Northrup potentiometer (type K).

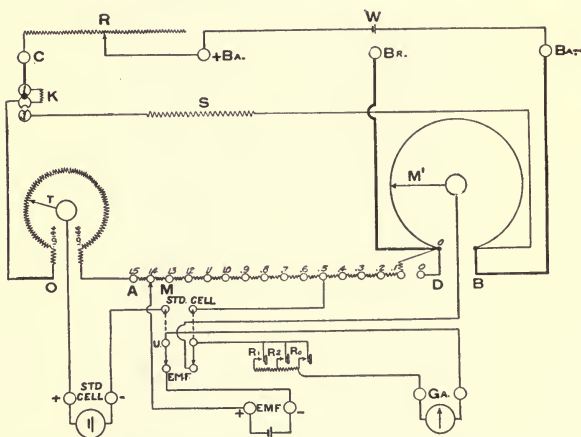

FIG. 114.—Wiring of the Leeds and Northrup potentiometer (type K).

in the potentiometer wire. The readings may be made to tenths and estimated to hundredths of a millivolt. These readings are then calculated, or read off from a table, to  $[H^+]$ ,  $[OH^-]$ , or pH.

#### CONVERSION TABLES SHOWING E.M.F., pH $[H^+]$ AND $[OH^-]$

The following tables computed by Schmidt and Hoagland<sup>1</sup> show the relation between the E. M. F. of normal and of tenth

<sup>1</sup> SCHMIDT and HOAGLAND, Univ. of Cal. Pub. in Phys., **5** (1919), 23-69.

normal potassium chloride-calomel cells and the pH,  $[H^+]$  and  $[OH^-]$ , of solutions measured at  $25^\circ C.$ , between normal  $[H^+]$  and normal  $[OH^-]$  in steps of 0.002 volt. If any other temperature than  $25^\circ$  is used, the observed E. M. F. should be multiplied by a factor to obtain the E. M. F. it would have at  $25^\circ$ , as follows:

Temperature	Factor	Temperature	Factor
18	1.024	25	1.000
19	1.021	26	0.996
20	1.017	27	0.993
21	1.014	28	0.990
22	1.010	29	0.987
23	1.007	30	0.983
24	1.004	..	.....

TABLE 71.—TABLES CONVERTING VOLTAGES OBSERVED WITH NORMAL AND TENTH NORMAL CALOMEL CELLS TO pH,  $[H^+]$ , AND  $[OH^-]$  (Schmidt and Hoagland)

$\frac{E_N}{1}$	$\frac{E_N}{10}$	pH	$\frac{CH^+}{N} \times \frac{OH^-}{H^+}$	$\frac{COH^-}{OH^-} \times 10^{-14}$	$\frac{E_N}{1}$	$\frac{E_N}{10}$	pH	$\frac{CH^+}{10^{-1} H^+}$	$\frac{COH^-}{OH^-} \times 10^{-13}$
0.283	0.336	.....	1.000	1.01	0.343	0.396	1.014	0.968	1.05
0.285	0.338	0.034	0.925	1.09	0.345	0.398	1.048	0.895	1.13
0.287	0.340	0.068	0.856	1.18	0.347	0.400	1.082	0.828	1.22
0.289	0.342	0.101	0.792	1.28	0.349	0.402	1.116	0.766	1.32
0.291	0.344	0.135	0.732	1.38	0.351	0.404	1.150	0.709	1.43
0.293	0.346	0.169	0.678	1.49	0.353	0.406	1.183	0.656	1.54
0.295	0.348	0.203	0.627	1.61	0.355	0.408	1.217	0.607	1.67
0.297	0.350	0.237	0.580	1.75	0.357	0.410	1.251	0.561	1.80
0.299	0.352	0.270	0.536	1.89	0.359	0.412	1.285	0.519	1.95
0.301	0.354	0.304	0.496	2.04	0.361	0.414	1.319	0.480	2.11
0.303	0.356	0.338	0.459	2.20	0.363	0.416	1.352	0.444	2.28
0.305	0.358	0.372	0.425	2.38	0.365	0.418	1.386	0.411	2.46
0.307	0.360	0.406	0.393	2.58	0.367	0.420	1.420	0.380	2.66
0.309	0.362	0.440	0.364	2.78	0.369	0.422	1.454	0.352	2.88
0.311	0.364	0.473	0.336	3.01	0.371	0.424	1.488	0.325	3.11
0.313	0.366	0.507	0.311	3.25	0.373	0.426	1.521	0.301	3.36
0.315	0.368	0.541	0.288	3.51	0.375	0.428	1.555	0.278	3.64
0.317	0.370	0.575	0.266	3.80	0.377	0.430	1.589	0.258	3.92
0.319	0.372	0.609	0.246	4.11	0.379	0.432	1.623	0.238	4.25
0.321	0.374	0.642	0.228	4.44	0.381	0.434	1.657	0.221	4.58
0.323	0.376	0.676	0.211	4.80	0.383	0.436	1.691	0.204	4.96
0.325	0.378	0.710	0.195	5.19	0.385	0.438	1.724	0.189	5.35
0.327	0.380	0.744	0.180	5.62	0.387	0.440	1.758	0.175	5.78
0.329	0.382	0.778	0.167	6.06	0.389	0.442	1.792	0.162	6.25
0.331	0.384	0.811	0.154	6.57	0.391	0.444	1.826	0.149	6.79
0.333	0.386	0.845	0.143	7.08	0.393	0.446	1.860	0.138	7.33
0.335	0.388	0.879	0.132	7.67	0.395	0.448	1.893	0.128	7.91
0.337	0.390	0.913	0.122	8.30	0.397	0.450	1.927	0.118	8.58
0.339	0.392	0.947	0.113	8.96	0.399	0.452	1.961	0.109	9.28
0.341	0.394	0.980	0.105	9.64	0.401	0.454	1.995	0.101	10.00

TABLE 71.—Continued

$E_N$ I	$E_N$ 10	pH	$C_{H^+}$ $\times 10^{-2}$	$C_{OH^-}$ $\times 10^{-12}$	$E_N$ I	$E_N$ 10	pH	$C_{H^+}$ $\times 10^{-3}$	$C_{OH^-}$ $\times 10^{-11}$
0.403	0.456	2.029	0.036	1.08	0.461	0.514	3.009	0.979	1.03
0.405	0.458	2.062	0.966	1.17	0.463	0.516	0.043	0.906	1.12
0.407	0.460	2.096	0.801	1.26	0.465	0.518	3.077	0.838	1.21
0.409	0.462	2.130	0.741	1.37	0.467	0.520	3.111	0.775	1.31
0.411	0.464	2.164	0.686	1.48	0.469	0.522	3.144	0.717	1.41
0.413	0.466	2.198	0.634	1.60	0.471	0.524	3.178	0.663	1.53
0.415	0.468	2.232	0.587	1.72	0.473	0.526	3.212	0.614	1.65
0.417	0.470	2.265	0.543	1.86	0.475	0.528	3.246	0.568	1.78
0.419	0.472	2.299	0.502	2.02	0.477	0.530	3.280	0.525	1.93
0.421	0.474	2.333	0.465	2.18	0.479	0.532	3.313	0.486	2.08
0.423	0.476	2.367	0.430	2.35	0.481	0.534	3.347	0.450	2.25
0.425	0.478	2.401	0.398	2.54	0.483	0.536	3.381	0.416	2.43
0.427	0.480	2.434	0.368	2.75	0.485	0.538	3.415	0.385	2.63
0.429	0.482	2.468	0.340	2.98	0.487	0.540	3.449	0.356	2.84
0.431	0.484	2.502	0.315	3.21	0.489	0.542	3.483	0.329	3.08
0.433	0.486	2.536	0.291	3.48	0.491	0.544	3.516	0.305	3.32
0.435	0.488	2.570	0.269	3.76	0.493	0.546	3.550	0.282	3.59
0.437	0.490	2.603	0.249	4.06	0.495	0.548	3.584	0.261	3.88
0.439	0.492	2.637	0.231	4.38	0.497	0.550	3.618	0.241	4.20
0.441	0.494	2.671	0.213	4.75	0.499	0.552	3.652	0.223	4.54
0.443	0.496	2.705	0.197	5.14	0.501	0.554	3.685	0.206	4.91
0.445	0.498	2.739	0.183	5.53	0.503	0.556	3.719	0.191	5.30
0.447	0.500	2.772	0.169	5.99	0.505	0.558	3.753	0.177	5.72
0.449	0.502	2.806	0.156	6.49	0.507	0.560	3.787	0.163	6.21
0.451	0.504	2.840	0.145	6.98	0.509	0.562	3.821	0.151	6.70
0.453	0.506	2.874	0.134	7.55	0.511	0.564	3.854	0.140	7.23
0.455	0.508	2.908	0.124	8.16	0.513	0.566	3.888	0.129	7.85
0.457	0.510	2.942	0.114	8.88	0.515	0.568	3.922	0.120	8.43
0.459	0.512	2.975	0.106	9.55	0.517	0.570	3.956	0.111	9.12
.....	.....	.....	.....	....	0.519	0.572	3.990	0.102	9.92



TABLE 71.—Continued

$\frac{E_N}{1}$	$\frac{E_N}{10}$	pH	$\frac{CH^+}{\times 10^{-4}} \frac{H^+}{H^+}$	$\frac{COH^-}{\times 10^{-10}} \frac{OH^-}{OH^-}$	$\frac{E_N}{1}$	$\frac{E_N}{10}$	pH	$\frac{CH^+}{\times 10^{-5}} \frac{H^+}{H^+}$	$\frac{COH^-}{\times 10^{-9}} \frac{OH^-}{OH^-}$
0.521	0.574	4.023	0.947	1.07	0.579	0.632	5.004	0.991	1.02
0.522	0.575	4.040	0.911	1.11	0.580	0.633	5.021	0.953	1.06
0.523	0.576	4.057	0.876	1.16	0.581	0.634	5.038	0.916	1.10
0.524	0.577	4.074	0.843	1.20	0.582	0.635	5.055	0.881	1.15
0.525	0.578	4.091	0.811	1.25	0.583	0.636	5.072	0.848	1.19
0.526	0.579	4.108	0.780	1.30	0.584	0.637	5.089	0.815	1.24
0.527	0.580	4.125	0.750	1.35	0.585	0.638	5.106	0.784	1.29
0.528	0.581	4.142	0.721	1.40	0.586	0.639	5.122	0.754	1.34
0.529	0.582	4.159	0.694	1.46	0.587	0.640	5.139	0.725	1.40
0.530	0.583	4.176	0.667	1.52	0.588	0.641	5.156	0.698	1.45
0.531	0.584	4.193	0.642	1.58	0.589	0.642	5.173	0.671	1.51
0.532	0.585	4.210	0.617	1.64	0.590	0.643	5.190	0.646	1.57
0.533	0.586	4.226	0.594	1.70	0.591	0.644	5.207	0.621	1.63
0.534	0.587	4.243	0.571	1.77	0.592	0.645	5.224	0.597	1.70
0.535	0.588	4.260	0.549	1.84	0.593	0.646	5.241	0.574	1.76
0.536	0.589	4.277	0.528	1.92	0.594	0.647	5.258	0.552	1.83
0.537	0.590	4.294	0.508	1.99	0.595	0.648	5.275	0.531	1.91
0.538	0.591	4.311	0.489	2.07	0.596	0.649	5.292	0.511	1.98
0.539	0.592	4.328	0.470	2.15	0.597	0.650	5.308	0.492	2.06
0.540	0.593	4.345	0.452	2.24	0.598	0.651	5.325	0.473	2.14
0.541	0.594	4.362	0.435	2.33	0.599	0.652	5.342	0.455	2.22
0.542	0.595	4.379	0.418	2.42	0.600	0.653	5.359	0.437	2.32
0.543	0.596	4.395	0.402	2.52	0.601	0.654	5.376	0.421	2.40
0.544	0.597	4.412	0.387	2.61	0.602	0.655	5.393	0.405	2.50
0.545	0.598	4.429	0.372	2.72	0.603	0.656	5.410	0.390	2.59
0.546	0.599	4.446	0.358	2.83	0.604	0.657	5.427	0.374	2.71
0.547	0.600	4.463	0.344	2.94	0.605	0.658	5.444	0.360	2.81
0.548	0.601	4.480	0.331	3.06	0.606	0.659	5.461	0.346	2.92
0.549	0.602	4.497	0.319	3.17	0.607	0.660	5.478	0.333	3.04
0.550	0.603	4.514	0.306	3.31	0.608	0.661	5.495	0.320	3.16
0.551	0.604	4.531	0.295	3.43	0.609	0.662	5.511	0.308	3.29
0.552	0.605	4.548	0.283	3.58	0.610	0.663	5.528	0.296	3.42
0.553	0.606	4.564	0.273	3.71	0.611	0.664	5.545	0.285	3.55
0.554	0.607	4.581	0.262	3.86	0.612	0.665	5.562	0.274	3.69
0.555	0.608	4.598	0.252	4.02	0.613	0.666	5.579	0.264	3.83
0.556	0.609	4.615	0.243	4.16	0.614	0.667	5.596	0.254	3.98
0.557	0.610	4.632	0.233	4.34	0.615	0.668	5.613	0.244	4.15
0.558	0.611	4.649	0.224	4.52	0.616	0.669	5.630	0.235	4.31
0.559	0.612	4.666	0.216	4.69	0.617	0.670	5.647	0.226	4.48
0.560	0.613	4.683	0.208	4.87	0.618	0.671	5.664	0.217	4.66
0.561	0.614	4.700	0.200	5.06	0.619	0.672	5.681	0.209	4.84
0.562	0.615	4.717	0.192	5.27	0.620	0.673	5.697	0.201	5.03
0.563	0.616	4.734	0.185	5.47	0.621	0.674	5.714	0.193	5.24
0.564	0.617	4.750	0.178	5.69	0.622	0.675	5.731	0.186	5.44
0.565	0.618	4.767	0.171	5.92	0.623	0.676	5.748	0.179	5.65
0.566	0.619	4.784	0.164	6.17	0.624	0.677	5.765	0.172	5.88
0.567	0.620	4.801	0.158	6.41	0.625	0.678	5.782	0.165	6.13
0.568	0.621	4.818	0.152	6.66	0.626	0.679	5.799	0.159	6.36
0.569	0.622	4.835	0.146	6.93	0.627	0.680	5.816	0.153	6.61
0.570	0.623	4.852	0.141	7.18	0.628	0.681	5.833	0.147	6.88
0.571	0.624	4.869	0.135	7.50	0.629	0.682	5.850	0.141	7.18
0.572	0.625	4.886	0.130	7.78	0.630	0.683	5.866	0.136	7.44
0.573	0.626	4.903	0.125	8.10	0.631	0.684	5.883	0.131	7.73
0.574	0.627	4.920	0.120	8.43	0.632	0.685	5.900	0.126	8.03
0.575	0.628	4.936	0.116	8.72	0.633	0.686	5.917	0.121	8.36
0.576	0.629	4.953	0.111	9.12	0.634	0.687	5.934	0.116	8.72
0.577	0.630	4.970	0.107	9.46	0.635	0.688	5.951	0.112	9.04
0.578	0.631	4.987	0.103	9.83	0.636	0.689	5.968	0.108	9.37
.....	.....	.....	.....	.....	0.637	0.690	5.985	0.104	9.73

TABLE 71.—Continued

$\frac{E_N}{1}$	$\frac{E_N}{10}$	pH	$\frac{CH^+}{\times 10^{-6}} \frac{H^+}{H^+}$	$\frac{COH^-}{\times 10^{-8}} \frac{OH^-}{OH^-}$	$\frac{E_N}{1}$	$\frac{E_N}{10}$	pH	$\frac{CH^+}{\times 10^{-7}} \frac{H^+}{H^+}$	$\frac{COH^-}{\times 10^{-7}} \frac{OH^-}{OH^-}$
0.638	0.691	6.002	0.996	1.02	0.698	0.751	7.016	0.964	1.05
0.639	0.692	6.019	0.958	1.06	0.699	0.752	7.033	0.927	1.09
0.640	0.693	6.036	0.921	1.10	0.700	0.753	7.050	0.892	1.13
0.641	0.694	6.052	0.886	1.14	0.701	0.754	7.067	0.858	1.18
0.642	0.695	6.069	0.852	1.19	0.702	0.755	7.084	0.825	1.23
0.643	0.696	6.086	0.820	1.23	0.703	0.756	7.100	0.794	1.27
0.644	0.697	6.103	0.789	1.28	0.704	0.757	7.117	0.763	1.33
0.645	0.698	6.120	0.758	1.34	0.705	0.758	7.134	0.734	1.38
0.646	0.699	6.137	0.729	1.39	0.706	0.759	7.151	0.706	1.43
0.647	0.700	6.154	0.702	1.44	0.707	0.760	7.168	0.679	1.49
0.648	0.701	6.171	0.675	1.50	0.708	0.761	7.185	0.653	1.55
0.649	0.702	6.188	0.649	1.56	0.709	0.762	7.202	0.628	1.61
0.650	0.703	6.204	0.625	1.62	0.710	0.763	7.219	0.604	1.68
0.651	0.704	6.221	0.601	1.68	0.711	0.764	7.236	0.581	1.74
0.652	0.705	6.238	0.578	1.75	0.712	0.765	7.253	0.559	1.81
0.653	0.706	6.255	0.556	1.82	0.713	0.766	7.269	0.538	1.88
0.654	0.707	6.272	0.535	1.89	0.714	0.767	7.286	0.517	1.96
0.655	0.708	6.289	0.514	1.97	0.715	0.768	7.303	0.497	2.04
0.656	0.709	6.306	0.495	2.04	0.716	0.769	7.320	0.478	2.12
0.657	0.710	6.323	0.476	2.13	0.717	0.770	7.337	0.460	2.20
0.658	0.711	6.340	0.458	2.21	0.718	0.771	7.354	0.443	2.28
0.659	0.712	6.357	0.440	2.30	0.719	0.772	7.371	0.426	2.38
0.660	0.713	6.373	0.423	2.39	0.720	0.773	7.388	0.409	2.47
0.661	0.714	6.390	0.407	2.49	0.721	0.774	7.405	0.394	2.57
0.662	0.715	6.407	0.392	2.58	0.722	0.775	7.422	0.379	2.68
0.663	0.716	6.424	0.377	2.68	0.723	0.776	7.439	0.364	2.77
0.664	0.717	6.441	0.362	2.80	0.724	0.777	7.455	0.350	2.89
0.665	0.718	6.458	0.348	2.91	0.725	0.778	7.472	0.337	3.00
0.666	0.719	6.475	0.335	3.02	0.726	0.779	7.489	0.324	3.12
0.667	0.720	6.492	0.322	3.14	0.727	0.780	7.506	0.312	3.24
0.668	0.721	6.509	0.310	3.26	0.728	0.781	7.523	0.300	3.37
0.669	0.722	6.526	0.298	3.40	0.729	0.782	7.540	0.288	3.51
0.670	0.723	6.543	0.287	3.53	0.730	0.783	7.557	0.277	3.65
0.671	0.724	6.559	0.276	3.67	0.731	0.784	7.574	0.267	3.79
0.672	0.725	6.576	0.265	3.82	0.732	0.785	7.591	0.257	3.94
0.673	0.726	6.593	0.255	3.97	0.733	0.786	7.608	0.247	4.10
0.674	0.727	6.610	0.245	4.13	0.734	0.787	7.624	0.238	4.25
0.675	0.728	6.627	0.236	4.29	0.735	0.788	7.641	0.228	4.44
0.676	0.729	6.644	0.227	4.46	0.736	0.789	7.658	0.220	4.60
0.677	0.730	6.661	0.218	4.64	0.737	0.790	7.675	0.211	4.80
0.678	0.731	6.678	0.210	4.82	0.738	0.791	0.692	0.203	4.99
0.679	0.732	6.695	0.202	5.01	0.739	0.792	7.709	0.195	5.19
0.680	0.733	6.712	0.194	5.22	0.740	0.793	7.726	0.188	5.38
0.681	0.734	6.728	0.187	5.41	0.741	0.794	7.743	0.181	5.59
0.682	0.735	6.745	0.180	5.62	0.742	0.795	7.760	0.174	5.82
0.683	0.736	6.762	0.173	5.85	0.743	0.796	7.777	0.167	6.06
0.684	0.737	6.779	0.166	6.10	0.744	0.797	7.794	0.161	6.29
0.685	0.738	6.796	0.160	6.32	0.745	0.798	7.810	0.155	6.53
0.686	0.739	6.813	0.154	6.57	0.746	0.799	7.827	0.149	6.79
0.687	0.740	6.830	0.148	6.84	0.747	0.800	7.844	0.143	7.08
0.688	0.741	6.847	0.142	7.13	0.748	0.801	7.861	0.138	7.33
0.689	0.742	6.864	0.137	7.39	0.749	0.802	7.878	0.132	7.67
0.690	0.743	6.881	0.132	7.67	0.750	0.803	7.895	0.127	7.97
0.691	0.744	6.898	0.127	7.97	0.751	0.804	7.912	0.123	8.23
0.692	0.745	6.914	0.122	8.30	0.752	0.805	7.929	0.118	8.58
0.693	0.746	6.931	0.117	8.65	0.753	0.806	7.946	0.113	8.96
0.694	0.747	6.948	0.113	8.96	0.754	0.807	7.963	0.109	9.28
0.695	0.748	6.965	0.108	9.37	0.755	0.808	7.980	0.105	9.64
0.696	0.749	6.982	0.104	9.73	0.756	0.809	7.996	0.101	10.02
* 0.697	0.750	6.999	0.100	10.12	.....	.....	.....	.....	.....

\* Neutral point.

$\frac{E_N}{1}$	$\frac{E_N}{10}$	pH	$\frac{CH^+}{\times 10^{-8}} \frac{H^+}{H^+}$	$\frac{COH^-}{\times 10^{-6}} \frac{OH^-}{OH^-}$	$\frac{E_N}{1}$	$\frac{E_N}{10}$	pH	$\frac{CH^+}{\times 10^{-9}} \frac{H^+}{H^+}$	$\frac{COH^-}{\times 10^{-5}} \frac{OH^-}{OH^-}$
0.757	0.810	8.013	0.970	1.04	0.816	0.869	9.011	0.975	1.04
0.758	0.811	8.030	0.933	1.08	0.817	0.870	9.028	0.938	1.08
0.759	0.812	8.047	0.897	1.13	0.818	0.871	9.045	0.902	1.12
0.760	0.813	8.064	0.863	1.17	0.819	0.872	9.062	0.868	1.17
0.761	0.814	8.081	0.830	1.22	0.820	0.873	9.078	0.835	1.21
0.762	0.815	8.098	0.798	1.27	0.821	0.874	9.095	0.803	1.26
0.763	0.816	8.115	0.768	1.32	0.822	0.875	9.112	0.772	1.31
0.764	0.817	8.132	0.739	1.37	0.823	0.876	9.129	0.743	1.36
0.765	0.818	8.149	0.710	1.43	0.824	0.877	9.146	0.714	1.42
0.766	0.819	8.165	0.683	1.48	0.825	0.878	9.163	0.687	1.47
0.767	0.820	8.182	0.657	1.54	0.826	0.879	9.180	0.661	1.53
0.768	0.821	8.199	0.632	1.60	0.827	0.880	9.197	0.636	1.59
0.769	0.822	8.216	0.608	1.66	0.828	0.881	9.214	0.611	1.66
0.770	0.823	8.233	0.585	1.73	0.829	0.882	9.231	0.588	1.72
0.771	0.824	8.250	0.562	1.80	0.830	0.883	9.248	0.566	1.79
0.772	0.825	8.267	0.541	1.87	0.831	0.884	9.264	0.544	1.86
0.773	0.826	8.284	0.520	1.95	0.832	0.885	9.281	0.523	1.93
0.774	0.827	8.301	0.500	2.02	0.833	0.886	9.298	0.503	2.01
0.775	0.828	8.318	0.481	2.10	0.834	0.887	9.315	0.484	2.09
0.776	0.829	8.335	0.463	2.19	0.835	0.888	9.332	0.466	2.17
0.777	0.830	8.351	0.445	2.27	0.836	0.889	9.349	0.448	2.26
0.778	0.831	8.368	0.428	2.36	0.837	0.890	9.366	0.431	2.35
0.779	0.832	8.385	0.412	2.46	0.838	0.891	9.383	0.414	2.44
0.780	0.833	8.402	0.396	2.56	0.839	0.892	9.400	0.398	2.54
0.781	0.834	8.419	0.381	2.66	0.840	0.893	9.417	0.383	2.64
0.782	0.835	8.436	0.367	2.76	0.841	0.894	9.434	0.369	2.74
0.783	0.836	8.453	0.353	2.87	0.842	0.895	9.450	0.354	2.86
0.784	0.837	8.470	0.339	2.99	0.843	0.896	9.467	0.341	2.97
0.785	0.838	8.487	0.326	3.10	0.844	0.897	9.484	0.328	3.09
0.786	0.839	8.504	0.314	3.22	0.845	0.898	9.501	0.315	3.21
0.787	0.840	8.521	0.302	3.35	0.846	0.899	9.518	0.304	3.33
0.788	0.841	8.537	0.290	3.49	0.847	0.900	9.535	0.292	3.47
0.789	0.842	8.554	0.279	3.63	0.848	0.901	9.552	0.281	3.60
0.790	0.843	8.571	0.269	3.76	0.849	0.902	9.569	0.270	3.75
0.791	0.844	8.588	0.258	3.92	0.850	0.903	9.585	0.260	3.89
0.792	0.845	8.605	0.248	4.08	0.851	0.904	9.602	0.250	4.05
0.793	0.846	8.622	0.239	4.23	0.852	0.905	9.619	0.240	4.22
0.794	0.847	8.639	0.230	4.40	0.853	0.906	9.636	0.231	4.38
0.795	0.848	8.656	0.221	4.58	0.854	0.907	9.653	0.222	4.56
0.796	0.849	8.673	0.213	4.75	0.855	0.908	9.670	0.214	4.73
0.797	0.850	8.690	0.204	4.96	0.856	0.909	9.687	0.206	4.91
0.798	0.851	8.706	0.197	5.14	0.857	0.910	9.704	0.198	5.11
0.799	0.852	8.723	0.189	5.35	0.858	0.911	9.721	0.190	5.33
0.800	0.853	8.740	0.182	5.56	0.859	0.912	9.738	0.183	5.53
0.801	0.854	8.757	0.175	5.78	0.860	0.913	9.755	0.176	5.75
0.802	0.855	8.774	0.168	6.02	0.861	0.914	9.772	0.169	5.99
0.803	0.856	8.791	0.162	6.25	0.862	0.915	9.788	0.163	6.21
0.804	0.857	8.808	0.156	6.49	0.863	0.916	9.805	0.157	6.45
0.805	0.858	8.825	0.150	6.75	0.864	0.917	9.822	0.151	6.70
0.806	0.859	8.842	0.144	7.03	0.865	0.918	9.839	0.145	6.98
0.807	0.860	8.859	0.139	7.28	0.866	0.919	9.856	0.139	7.28
0.808	0.861	8.876	0.133	7.61	0.867	0.920	9.873	0.134	7.55
0.809	0.862	8.892	0.128	7.91	0.868	0.921	9.890	0.129	7.84
0.810	0.863	8.909	0.123	8.23	0.869	0.922	9.907	0.124	8.16
0.811	0.864	8.926	0.119	8.50	0.870	0.923	9.924	0.119	8.50
0.812	0.865	8.943	0.114	8.88	0.871	0.924	9.941	0.115	8.80
0.813	0.866	8.960	0.110	9.20	0.872	0.925	9.958	0.110	9.20
0.814	0.867	8.977	0.106	9.55	0.873	0.926	9.974	0.106	9.55
0.815	0.868	8.994	0.101	10.00	0.874	0.927	9.991	0.102	9.92

$\frac{E_N}{1}$	$\frac{E_N}{10}$	pH	$\frac{CH^+}{H^+} \times 10^{-10}$	$\frac{COH^-}{OH^-} \times 10^{-4}$	$\frac{E_N}{1}$	$\frac{E_N}{10}$	pH	$\frac{CH^+}{H^+} \times 10^{-11}$	$\frac{COH^-}{OH^-} \times 10^{-3}$
0.875	0.928	10.008	0.981	1.03	0.935	0.988	11.022	0.950	1.07
0.877	0.930	10.042	0.908	1.11	0.937	0.990	11.056	0.879	1.15
0.879	0.932	10.076	0.840	1.20	0.939	0.992	11.090	0.813	1.24
0.881	0.934	10.110	0.777	1.30	0.941	0.994	11.124	0.752	1.35
0.883	0.936	10.143	0.719	1.41	0.943	0.996	11.158	0.696	1.45
0.885	0.938	10.177	0.665	1.52	0.945	0.998	11.191	0.644	1.57
0.887	0.940	10.211	0.615	1.65	0.947	1.000	11.225	0.595	1.70
0.889	0.942	10.245	0.569	1.78	0.949	1.002	11.259	0.551	1.84
0.891	0.944	10.279	0.526	1.92	0.951	1.004	11.293	0.509	1.99
0.893	0.946	10.313	0.487	2.08	0.953	1.006	11.327	0.471	2.15
0.895	0.948	10.346	0.451	2.24	0.955	1.008	11.361	0.436	2.32
0.897	0.950	10.380	0.417	2.43	0.957	1.010	11.394	0.403	2.51
0.899	0.952	10.414	0.386	2.62	0.959	1.012	11.428	0.373	2.71
0.901	0.954	10.448	0.357	2.83	0.961	1.014	11.462	0.345	2.93
0.903	0.956	10.481	0.330	3.07	0.963	1.016	11.496	0.319	3.17
0.905	0.958	10.515	0.305	3.32	0.965	1.018	11.530	0.295	3.43
0.907	0.960	10.549	0.282	3.59	0.967	1.020	11.563	0.273	3.71
0.909	0.962	10.583	0.261	3.88	0.969	1.022	11.597	0.253	4.00
0.911	0.964	10.617	0.242	4.18	0.971	1.024	11.631	0.234	4.32
0.913	0.966	10.651	0.224	4.52	0.973	1.026	11.665	0.216	4.69
0.915	0.968	10.684	0.207	4.89	0.975	1.028	11.699	0.200	5.06
0.917	0.970	10.718	0.191	5.30	0.977	1.030	11.732	0.185	5.47
0.919	0.972	10.752	0.177	5.72	0.979	1.032	11.766	0.171	5.92
0.921	0.974	10.786	0.164	6.17	0.981	1.034	11.800	0.159	6.36
0.923	0.976	10.820	0.152	6.66	0.983	1.036	11.834	0.147	6.88
0.925	0.978	10.853	0.140	7.23	0.985	1.038	11.868	0.136	7.44
0.927	0.980	10.887	0.130	7.78	0.987	1.040	11.901	0.126	8.03
0.929	0.982	10.921	0.120	8.43	0.989	1.042	11.935	0.116	8.72
0.931	0.984	10.955	0.111	9.12	0.991	1.044	11.969	0.107	9.46
0.933	0.986	10.989	0.103	9.83	.....	.....	.....	.....	.....

$\frac{E_N}{1}$	$\frac{E_N}{10}$	pH	$\frac{CH^+}{H^+} \times 10^{-12}$	$\frac{COH^-}{OH^-} \times 10^{-2}$	$\frac{E_N}{1}$	$\frac{E_N}{10}$	pH	$\frac{CH^+}{H^+} \times 10^{-13}$	$\frac{COH^-}{OH^-} \times 10^{-1}$
0.993	1.046	12.003	0.993	1.02	1.053	1.106	13.017	0.961	1.05
0.995	1.048	12.037	0.919	1.10	1.055	1.108	13.051	0.889	1.14
0.997	1.050	12.071	0.850	1.19	1.057	1.110	13.085	0.822	1.23
0.999	1.052	12.104	0.786	1.29	1.059	1.112	13.119	0.761	1.33
1.001	1.054	12.138	0.728	1.39	1.061	1.114	13.153	0.704	1.44
1.003	1.056	12.172	0.673	1.50	1.063	1.116	13.186	0.651	1.55
1.005	1.058	12.206	0.623	1.62	1.065	1.118	13.220	0.602	1.68
1.007	1.060	12.240	0.576	1.76	1.067	1.120	13.254	0.557	1.82
1.009	1.062	12.273	0.533	1.90	1.069	1.122	13.288	0.516	1.96
1.011	1.064	12.307	0.493	2.05	1.071	1.124	13.322	0.477	2.12
1.013	1.066	12.341	0.456	2.22	1.073	1.126	13.355	0.441	2.29
1.015	1.068	12.375	0.422	2.40	1.075	1.128	13.389	0.408	2.48
1.017	1.070	12.409	0.390	2.59	1.077	1.130	13.423	0.378	2.68
1.019	1.072	12.443	0.361	2.80	1.079	1.132	13.457	0.349	2.90
1.021	1.074	12.476	0.334	3.03	1.081	1.134	13.491	0.323	3.13
1.023	1.076	12.510	0.309	3.28	1.083	1.136	13.524	0.299	3.38
1.025	1.078	12.544	0.286	3.54	1.085	1.138	13.558	0.277	3.65
1.027	1.080	12.578	0.264	3.83	1.087	1.140	13.592	0.256	3.95
1.029	1.082	12.612	0.245	4.13	1.089	1.142	13.626	0.237	4.27
1.031	1.084	12.645	0.226	4.48	1.091	1.144	13.660	0.219	4.62
1.033	1.086	12.679	0.209	4.84	1.093	1.146	13.693	0.203	4.99
1.035	1.088	12.713	0.194	5.22	1.095	1.148	13.727	0.187	5.41
1.037	1.090	12.747	0.179	5.65	1.097	1.150	13.761	0.173	5.85
1.039	1.092	12.781	0.166	6.10	1.099	1.152	13.795	0.160	6.32
1.041	1.094	12.814	0.153	6.61	1.101	1.154	13.829	0.148	6.84
1.043	1.096	12.848	0.142	7.13	1.103	1.156	13.863	0.137	7.39
1.045	1.098	12.882	0.131	7.73	1.105	1.158	13.896	0.127	7.97
1.047	1.100	12.916	0.121	8.36	1.107	1.160	13.930	0.117	8.65
1.049	1.102	12.950	0.112	9.04	1.109	1.162	13.964	0.109	9.28
1.051	1.104	12.983	0.104	9.73	1.111	1.164	13.998	0.101	10.02
.....	.....	.....	.....	.....	1.113	1.166	14.032	$\times 10^{-14}$ H <sup>+</sup>	$\times$ N OH <sup>-</sup> 1.09



**The Theory of Indicators and the Colorimetric Determination.**—The hydrogen ion concentration of glue and gelatin solutions may be determined with somewhat less accuracy but with greater rapidity by the colorimetric than by the electrometric procedure. For purposes of plant control where the niceties obtainable by the latter method are not necessary, a reasonably close approximation may be obtained in a minimum of time by the colorimetric procedure.

This method depends upon the fact that many organic substances are capable of internal tautomeric rearrangements of their molecules under the influence of hydrogen or hydroxyl ions with a corresponding change in color. These compounds, commonly designated as indicators, are for the most part very weak acids. They are consequently undissociated in the presence of a certain concentration of hydrogen ion, but as that value becomes less, as by the addition of alkali, they become dissociated. Their value as indicators lies in the fact that the undissociated molecule has a color which is different from that of the tautomeric rearrangement which takes place coincident with the formation of its ions. The useful range in color change of the indicators is usually about 1.5 pH. Thus phenol red is yellow in solutions more acid than pH 6.6, and is red in solutions more alkaline than pH 8.2. Between these values, however, the change in shade of color is gradual and the development of any given shade or *virage* signifies a definite and fixed pH of the solution.

A great variety of indicators have been reported by Salm,<sup>1</sup> Sørensen,<sup>2</sup> Thiel<sup>3</sup> and others. Clark and Lubs<sup>4</sup> have developed the sulphonphthalein series which have proved of exceptional value on account of their great brilliance of color and sharply defined color changes. These give a useful pH range of from 1.2 to 10.0. The following table shows the chemical name, the common name, the most favorable concentration for use, the color change, and the pH range of this series.

In Fig. 115 is shown the dissociation of these indicators as expressed by Clark, and the effective range for each.

The indicators listed below are obtainable from any chemical

<sup>1</sup> E. SALM, *Z physik. Chem.*, **57** (1906), 471.

<sup>2</sup> S. SØRENSEN, *Biochem Z*, **21** (1909), 131, 201.

<sup>3</sup> A. THIEL, *Sammlung, chem. chemtech. Vorträge*, **16** (1911), 307.

<sup>4</sup> W. CLARK and H. LUBS, *J. Bact.*, **2** (1917), 1; 109; 191.

TABLE 72.—CLARK AND LUBS' LIST OF INDICATORS<sup>1</sup>

Chemical name	Common name	Concentration, per cent	Color change	Range pH
Thymolsulphonphthalein.....	Thymol blue	0.04	Red-yellow	1.2-2.8
Tetrabromophenolsulphonphthalein.....	Brom phenol blue	0.04	Yellow-blue	3.0-4.6
Orthocarboxybenzeneazodimethylaniline.....	Methyl red	0.02	Red-yellow	4.4-6.0
Dibromoorthocresolsulphonphthalein.....	Brom cresol purple	0.04	Yellow-purple	5.2-6.8
Dibromothymolsulphonphthalein.....	Brom thymol blue	0.04	Yellow-blue	6.0-7.6
Phenolsulphonphthalein.....	Phenol red	0.02	Yellow-red	6.8-8.4
Orthocresolsulphonphthalein.....	Cresol red	0.02	Yellow-red	7.2-8.8
Thymolsulphonphthalein.....	Thymol blue	0.04	Yellow-blue	8.0-9.6
Orthocresolsulphonphthalein.....	Cresol phthalein	0.02	Colorless-red	8.2-9.8

<sup>1</sup> W. M. CLARK, "The Determination of Hydrogen Ions," Baltimore (1920), 65.

supply house in the form of a dry powder, and in stock solutions, and tablets. Alcoholic solutions may be used where the alcohol is not objectionable and where the free acid dye in the indicator solution does not vitiate accuracy, but Clark and Lubs prefer the use of aqueous solutions of alkali salts. Rather concentrated solutions are conveniently made up, and diluted to the appropriate strength for use from time to time as needed.

The stock solutions are prepared as follows:<sup>1</sup> One decigram (0.1 gram) of the dry powder is ground in an agate mortar with the quantities of N/20 NaOH listed in Table 73. When solutions are complete they are diluted to 25 c.c.

After making up to 25 c.c. the dye is present as a 0.4 per cent solution. For use in testing 10 c.c. portions of a solution with five drops of indicator solution, 5 c.c. portions of brom phenol blue, brom cresol purple, thymol blue, and brom thymol blue, and 2.5 c.c. portions of phenol red, cresol red, and methyl red are made up to a volume of 50 c.c. each. This results in a concentration of 0.04 per cent for the former and 0.02 per cent for the latter set listed. Ortho cresol phthalein (and phenolphthalein if used) are made up into 0.02 per cent solutions in 95 per cent alcohol.

In using indicator solutions prepared as above, five drops are added to 10 c.c. of the solution to be tested, and the color compared with that developed by the addition of a similar amount

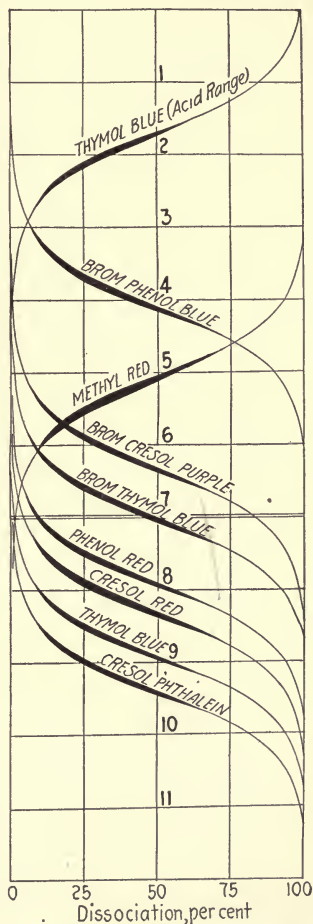

FIG. 115.—Indicator curves and significant pH values (Clark and Lubs). (From W. M. Clark, "The Determination of Hydrogen Ions," Williams and Wilkins Company, Baltimore, 1920.)

<sup>1</sup> From directions of W. M. CLARK, *lib. cit.*

TABLE 73.—PREPARATION OF INDICATOR SOLUTIONS

Molecular weight	Indicator	N/20 NaOH per deci-gram, <i>cubic centimeters</i>
354.17	Phenol red	5.7
669.82	Brom phenol blue	3.0
382.17	Cresol red	5.3
540.01	Brom cresol purple	3.7
466.30	Thymol blue	4.3
624.12	Brom thymol blue	3.2
269.12	Methyl red	7.4

of indicator solution to 10 c.c. portions of solutions of known standard pH. For this purpose solutions possessing a decided buffer action (*vide* page 587) are selected, as they may be accurately reproduced and represent pH values that do not alter through trivial variations in operation. Several such series of buffer solutions have been suggested which vary in their pH, as determined by electrometric calibration, by 0.2. This variation is arbitrarily fixed as most convenient, but may be altered at will.

The set described by Clark and Lubs<sup>1</sup> seem more convenient of preparation and somewhat more satisfactory in service than the others, and alone will be described. It is composed of the following mixtures:

- Potassium chloride + hydrochloric acid.
- Acid potassium phthalate + hydrochloric acid.
- Acid potassium phthalate + sodium hydroxide.
- Acid potassium phosphate + sodium hydroxide.
- Boric acid + potassium chloride + sodium hydroxide.

The following stock solutions are required:

M/5 potassium chloride solution, prepared from recrystallized and thoroughly dried (at 120°C. for 2 days) material, using 14.912 grams per liter of solution.

M/5 acid potassium phthalate solution, prepared from recrystallized and well dried material, using 40.828 grams per liter of solution.

M/5 acid potassium phosphate solution, prepared from recrystallized and well dried material, using 27.232 grams per liter of solution.

M/5 boric acid M/5 potassium chloride solution. The boric acid should be recrystallized and dried in thin layers between filter paper. A liter of the solution should contain 12.4048 grams of boric acid and 14.912 grams of potassium chloride.

<sup>1</sup> W. M. CLARK and H. LUBS, *J. Biol. Chem.*, **25** (1916), 479.



M/5 sodium hydroxide must be prepared as free as possible from carbonates, and preserved in paraffined bottles, protected from the air with soda-lime tubes.

M/5 hydrochloric acid solution is made in the usual way and carefully checked against the sodium hydroxide.

The standard solutions of pH varying from 1.2 to 10.0 by intervals of 0.2 pH are made up from the above stock solutions according to the following table. By employing buffer solutions varying by 0.2 pH it is easily possible to estimate values in unknown solutions to the nearest tenth. The solutions are best kept in 200 c.c. bottles each provided with a cork stopper in which is inserted a 10 c.c. pipette, sealed with a closed rubber tube at the upper end.

The approximate pH of the solution to be tested is first noted by adding a few drops of several indicators to small portions of the solution in a test tube. That indicator which more nearly

TABLE 74.—CLARK AND LUBS' BUFFER SOLUTIONS<sup>1</sup>

KCl-HCl Mixtures			
pH			
1.2	50 c.c. M/5 KCl	64.5 c.c. M/5 HCl	Dilute to 200 c.c.
1.4	50 c.c. M/5 KCl	41.5 c.c. M/5 HCl	Dilute to 200 c.c.
1.6	50 c.c. M/5 KCl	26.3 c.c. M/5 HCl	Dilute to 200 c.c.
1.8	50 c.c. M/5 KCl	16.6 c.c. M/5 HCl	Dilute to 200 c.c.
2.0	50 c.c. M/5 KCl	10.6 c.c. M/5 HCl	Dilute to 200 c.c.
2.2	50 c.c. M/5 KCl	6.7 c.c. M/5 HCl	Dilute to 200 c.c.
Phthalate-HCl Mixtures			
2.2	50 c.c. M/5 KH phthalate	46.70 c.c. M/5 HCl	Dilute to 200 c.c.
2.4	50 c.c. M/5 KH phthalate	39.60 c.c. M/5 HCl	Dilute to 200 c.c.
2.6	50 c.c. M/5 KH phthalate	32.95 c.c. M/5 HCl	Dilute to 200 c.c.
2.8	50 c.c. M/5 KH phthalate	26.42 c.c. M/5 HCl	Dilute to 200 c.c.
3.0	50 c.c. M/5 KH phthalate	20.32 c.c. M/5 HCl	Dilute to 200 c.c.
3.2	50 c.c. M/5 KH phthalate	14.70 c.c. M/5 HCl	Dilute to 200 c.c.
3.4	50 c.c. M/5 KH phthalate	9.90 c.c. M/5 HCl	Dilute to 200 c.c.
3.6	50 c.c. M/5 KH phthalate	5.97 c.c. M/5 HCl	Dilute to 200 c.c.
3.8	50 c.c. M/5 KH phthalate	2.63 c.c. M/5 HCl	Dilute to 200 c.c.
Phthalate-NaOH Mixtures			
4.0	50 c.c. M/5 KH phthalate	0.40 c.c. M/5 NaOH	Dilute to 200 c.c.
4.2	50 c.c. M/5 KH phthalate	3.70 c.c. M/5 NaOH	Dilute to 200 c.c.
4.4	50 c.c. M/5 KH phthalate	7.50 c.c. M/5 NaOH	Dilute to 200 c.c.
4.6	50 c.c. M/5 KH phthalate	12.15 c.c. M/5 NaOH	Dilute to 200 c.c.
4.8	50 c.c. M/5 KH phthalate	17.70 c.c. M/5 NaOH	Dilute to 200 c.c.
5.0	50 c.c. M/5 KH phthalate	23.85 c.c. M/5 NaOH	Dilute to 200 c.c.
5.2	50 c.c. M/5 KH phthalate	29.95 c.c. M/5 NaOH	Dilute to 200 c.c.
5.4	50 c.c. M/5 KH phthalate	35.45 c.c. M/5 NaOH	Dilute to 200 c.c.
5.6	50 c.c. M/5 KH phthalate	39.85 c.c. M/5 NaOH	Dilute to 200 c.c.
5.8	50 c.c. M/5 KH phthalate	43.00 c.c. M/5 NaOH	Dilute to 200 c.c.
6.0	50 c.c. M/5 KH phthalate	45.45 c.c. M/5 NaOH	Dilute to 200 c.c.
6.2	50 c.c. M/5 KH phthalate	47.00 c.c. M/5 NaOH	Dilute to 200 c.c.

<sup>1</sup> W. M. CLARK, *lib. cit.*, 75.

KH<sub>2</sub>PO<sub>4</sub>-NaOH Mixtures

5.8	50 c.c. M/5 KH <sub>2</sub> PO <sub>4</sub>	3.72 c.c. M/5 NaOH	Dilute to 200 c.c.
6.0	50 c.c. M/5 KH <sub>2</sub> PO <sub>4</sub>	5.70 c.c. M/5 NaOH	Dilute to 200 c.c.
6.2	50 c.c. M/5 KH <sub>2</sub> PO <sub>4</sub>	8.60 c.c. M/5 NaOH	Dilute to 200 c.c.
6.4	50 c.c. M/5 KH <sub>2</sub> PO <sub>4</sub>	12.60 c.c. M/5 NaOH	Dilute to 200 c.c.
6.6	50 c.c. M/5 KH <sub>2</sub> PO <sub>4</sub>	17.80 c.c. M/5 NaOH	Dilute to 200 c.c.
6.8	50 c.c. M/5 KH <sub>2</sub> PO <sub>4</sub>	23.65 c.c. M/5 NaOH	Dilute to 200 c.c.
7.0	50 c.c. M/5 KH <sub>2</sub> PO <sub>4</sub>	29.63 c.c. M/5 NaOH	Dilute to 200 c.c.
7.2	50 c.c. M/5 KH <sub>2</sub> PO <sub>4</sub>	35.00 c.c. M/5 NaOH	Dilute to 200 c.c.
7.4	50 c.c. M/5 KH <sub>2</sub> PO <sub>4</sub>	39.50 c.c. M/5 NaOH	Dilute to 200 c.c.
7.6	50 c.c. M/5 KH <sub>2</sub> PO <sub>4</sub>	42.80 c.c. M/5 NaOH	Dilute to 200 c.c.
7.8	50 c.c. M/5 KH <sub>2</sub> PO <sub>4</sub>	45.20 c.c. M/5 NaOH	Dilute to 200 c.c.
8.0	50 c.c. M/5 KH <sub>2</sub> PO <sub>4</sub>	46.80 c.c. M/5 NaOH	Dilute to 200 c.c.

## Boric acid-KCl-NaOH Mixtures

7.8	50 c.c. M/5 H <sub>3</sub> BO <sub>3</sub> , M/5 KCl	2.61 c.c. M/5 NaOH	Dilute to 200 c.c.
8.0	50 c.c. M/5 H <sub>3</sub> BO <sub>3</sub> , M/5 KCl	3.97 c.c. M/5 NaOH	Dilute to 200 c.c.
8.2	50 c.c. M/5 H <sub>3</sub> BO <sub>3</sub> , M/5 KCl	5.90 c.c. M/5 NaOH	Dilute to 200 c.c.
8.4	50 c.c. M/5 H <sub>3</sub> BO <sub>3</sub> , M/5 KCl	8.50 c.c. M/5 NaOH	Dilute to 200 c.c.
8.6	50 c.c. M/5 H <sub>3</sub> BO <sub>3</sub> , M/5 KCl	12.00 c.c. M/5 NaOH	Dilute to 200 c.c.
8.8	50 c.c. M/5 H <sub>3</sub> BO <sub>3</sub> , M/5 KCl	16.30 c.c. M/5 NaOH	Dilute to 200 c.c.
9.0	50 c.c. M/5 H <sub>3</sub> BO <sub>3</sub> , M/5 KCl	21.30 c.c. M/5 NaOH	Dilute to 200 c.c.
9.2	50 c.c. M/5 H <sub>3</sub> BO <sub>3</sub> , M/5 KCl	26.70 c.c. M/5 NaOH	Dilute to 200 c.c.
9.4	50 c.c. M/5 H <sub>3</sub> BO <sub>3</sub> , M/5 KCl	32.00 c.c. M/5 NaOH	Dilute to 200 c.c.
9.6	50 c.c. M/5 H <sub>3</sub> BO <sub>3</sub> , M/5 KCl	36.85 c.c. M/5 NaOH	Dilute to 200 c.c.
9.8	50 c.c. M/5 H <sub>3</sub> BO <sub>3</sub> , M/5 KCl	40.80 c.c. M/5 NaOH	Dilute to 200 c.c.
10.0	50 c.c. M/5 H <sub>3</sub> BO <sub>3</sub> , M/5 KCl	43.90 c.c. M/5 NaOH	Dilute to 200 c.c.

measures the pH noted is then added to 10 c.c. portions of the buffer solutions of pH values on either side of the approximate value observed, and the color developed in 10 c.c. of the unknown solution by the addition of five drops of the indicator compared to that of the buffer mixtures. The assumption is made that if the same virage is produced in any two solutions, the pH of the two is the same. This is not always strictly true, as will be described later.

Where only approximate results are required, the buffer solutions may be dispensed with and a color chart, such as shown in Clark's book (*lib. cit.*) referred to. After considerable practice the "color memory" alone may be safely relied upon for rough work.

*Sources of Error in Colorimetric Determinations.*—If there are present in the solution being tested substances that adsorb the indicator, or otherwise remove it from the field of action, the equilibria upon which the color depends may be altered to such an extent that not only the intensity but even the quality of the color will be quite different from that observed in a solution of the same pH in which such disturbing influences are not present. In all such cases of discrepancy the electrometric estimation is taken, whether correctly or not, as the basic value. These non-

conformities, known as *protein errors*, on account of their frequent occurrence in proteins, are said to be larger the more complex and concentrated the proteins, and less noticeable in the products of hydrolysis. Benedict and Elliott<sup>1</sup> have shown in a study upon gelatin that some indicators show a higher pH than the hydrogen electrode, some show a lower pH, and that no stated correction may be properly applied because the electrometric and colorimetric curves at different pH values do not run parallel. In some instances the curves may even cross, *e.g.*, at one pH the colorimetric method may show a higher, and at another pH a lower value than the corresponding determination by electrometric means.

Clark<sup>2</sup> has reported the exact relation between pH obtained colorimetrically with methyl red and by the hydrogen electrode of casein solutions between pH 2 and 6.

Another discrepancy between the two methods for measuring pH is found to be due to the presence of inorganic salts in different amounts. Perfectly neutral salts such as sodium chloride are capable, in some way, of affecting the equilibria so that different intensities and shades of color are produced with the different indicators. No adequate explanation has been offered to account for this so-called *salt effect*. In measurements where the salt effect or protein effect are constant, they may be eliminated by a calibration of such solutions with the indicators against the hydrogen electrode, but if the salt or protein content is variable such a procedure becomes impracticable. The best way to deal with such cases seems to be to select only such indicators as give a relatively small error, and keep in mind the general order of magnitude expected. But for the most reliable work the electrometric procedure must be used.

A natural strong coloration or turbidity in the solution makes colorimetric determinations very difficult. A considerable dilution may be employed (at least to 1.0 per cent) but if such a solution is still highly colored or turbid the virage on adding the indicator will be markedly different from that produced in a clear and colorless solution of the same pH. There have been a number of schemes suggested to make comparisons possible in such cases, and with a fair degree of success. The simplest, and

<sup>1</sup> A. BENEDICT and F. ELLIOTT, paper read at 60th Gen. Meeting, Am. Chem. Soc., Chicago, 1920.

<sup>2</sup> W. M. CLARK, *et. al.*, *J. Ind. Eng. Chem.*, **12** (1920), 1163.

perhaps most effective, method of overcoming the color and turbidity errors is by the use of a *color comparator* as proposed by Hurwitz, Meyer, and Ostenberg.<sup>1</sup> This consists merely of a block of wood (Fig. 116), painted dull black in which are bored six holes in pairs, parallel to each other, of such size as will hold an ordinary test tube. Adjacent pairs are bored very close



FIG. 116.—A color comparator.

together. Smaller holes are bored perpendicular to these and passing through each pair. In the front center hole is placed the tube containing the solution being tested plus the indicator. Behind this is placed a tube of clear water. On either side in front are placed the standard buffer solutions colored with the indicator, and behind each of these a tube of the solution being tested, but without any indicator. Both color and turbidity are in that way properly compensated in all solutions. Turbid solutions should always be viewed through a thin layer, that is, through the sides of test tubes rather than from the top.

## 2. IONIZATION CONSTANTS OF ACIDS AND BASES

Figure 117 shows graphically the relation between hydrogen ion concentration and pH, together with the ranges of some common indicators and the approximate points on the curve of some common substances.

<sup>1</sup> S. HURWITZ, K. MEYER, and Z. OSTENBERG, *Proc. Soc. Exptl. Biol. Med.*, **13** (1915), 24.



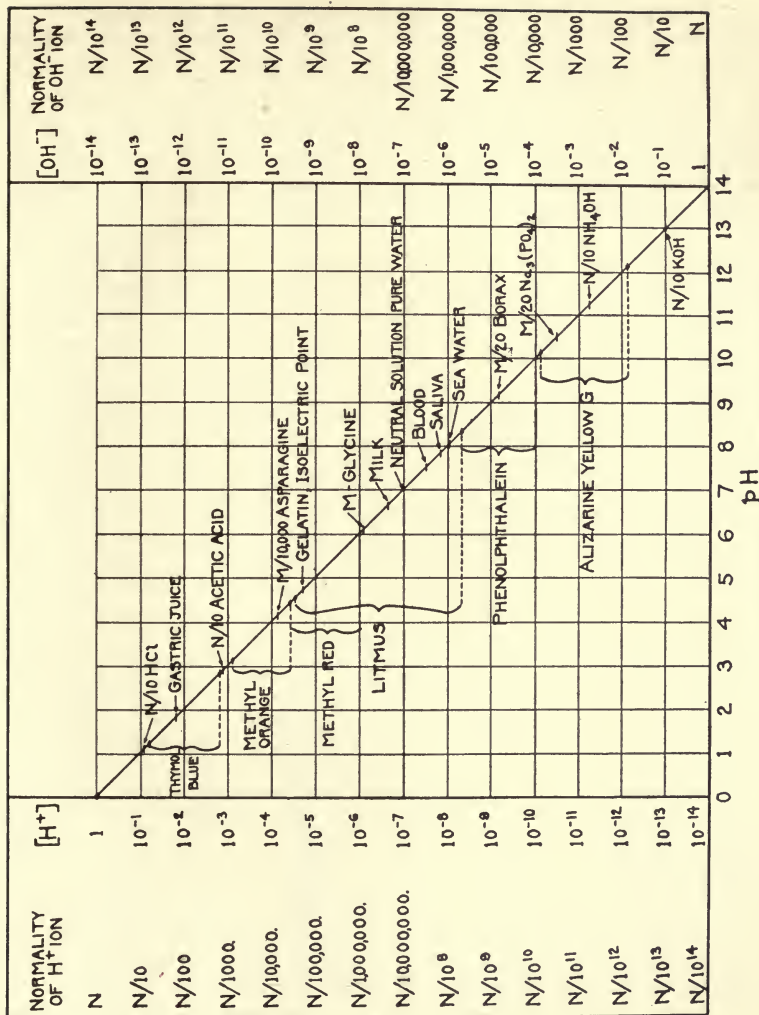

Fig. 117.—Hydrogen ion concentration and pH.

TABLE 75.—IONIZATION CONSTANTS OF ACIDS AND BASES<sup>1</sup>

Ionogen	$K_x$	K
Acetic acid.....	$K_a$	$1.8 \times 10^{-5}$
Amino acetic acid.....	$K_a$	$1.8 \times 10^{-10}$
Amino acetic acid.....	$K_b$	$2.8 \times 10^{-12}$
Ammonium hydroxide.....	$K_b$	$1.8 \times 10^{-5}$
Aspartic acid.....	$K_a$	$1.4 \times 10^{-4}$
Aspartic acid.....	$K_b$	$1.2 \times 10^{-12}$
Barium hydroxide.....	$K_b$	$3.0 \times 10^{-2}$
Boric acid.....	$K_{a1}$	$7.0 \times 10^{-10}$
Calcium hydroxide.....	$K_b$	$3.0 \times 10^{-2}$
Carbonic acid.....	$K_{a1}$	$3.0 \times 10^{-7}$
Carbonic acid.....	$K_{a2}$	$7.0 \times 10^{-11}$
Citric acid.....	$K_{a1}$	$8.2 \times 10^{-4}$
Citric acid.....	$K_{a2}$	$3.2 \times 10^{-5}$
Citric acid.....	$K_{a3}$	$7.0 \times 10^{-7}$
Formic acid.....	$K_a$	$2.1 \times 10^{-4}$
Hydrochloric acid.....	$K_a$	1.0
Lactic acid.....	$K_a$	$1.4 \times 10^{-4}$
Lysine.....	$K_a$	$1.0 \times 10^{-11}$
Lysine.....	$K_b$	$1.0 \times 10^{-7}$
Nitric acid.....	$K_a$	1.0
Nitrous acid.....	$K_a$	$6.0 \times 10^{-4}$
Oxalic acid.....	$K_{a1}$	$1.0 \times 10^{-1}$
Oxalic acid.....	$K_{a2}$	$4.1 \times 10^{-5}$
Phosphoric acid.....	$K_{a1}$	$1.0 \times 10^{-2}$
Phosphoric acid.....	$K_{a2}$	$2.0 \times 10^{-7}$
Phosphoric acid.....	$K_{a3}$	$4.0 \times 10^{-13}$
Potassium hydroxide.....	$K_b$	1.0
Sodium hydroxide.....	$K_b$	1.0
Sulphuric acid.....	$K_{a1}$	1.0
Sulphuric acid.....	$K_{a2}$	$3.0 \times 10^{-2}$

$K_a$  = acid ionization;  $K_b$  = basic ionization; 1, 2, 3 refer to primary, secondary, and tertiary ionization.

### 3. THE CONVERSION OF MACMICHAEL VISCOSITY DEGREES TO CENTIPOISES

The MacMichael viscosimeter is most conveniently calibrated to absolute viscosity units, or centipoises, by taking the viscosity in MacMichael degrees, at a number of different temperatures, of a liquid the absolute viscosity of which, at the temperatures

<sup>1</sup> J. STEGLITZ, "Qualitative Chemical Analysis," (1916), 104; 106; CLARK, *lib. cit.*, 308.

employed, has been definitely established. At the advice of the United States Bureau of Standards,<sup>1</sup> castor oil of the highest purity is recommended as the calibrating liquid.

The speed of rotation of the cup should be regulated to a stated velocity between 20 and 60 revolutions per minute, and at all times ascertained to revolve at the stated speed. Each instrument must be calibrated separately for each wire that is to be employed.

The author has found the conversion curve of MacMichael degrees to centipoises to be a straight line, and it is, therefore, necessary to take readings at only three or four different temperatures to establish the curve for all temperatures. This done, the absolute viscosity in centipoises may be read off directly from the graph for any corresponding MacMichael degree.

The viscosity in centipoises of castor oil at numerous temperatures from 5 to 100°C. is reported in the United States Bureau of Standards Technologic Paper No. 112 (1919), pages 24 and 25. A part of the data there given is reproduced below:

TABLE 76.—ABSOLUTE VISCOSITY OF CASTOR OIL

Temperature	Viscosity in centipoises	Temperature	Viscosity in centipoises
18.0	1162.5	32.0	394.0
20.0	986.0	34.0	340.0
22.0	834.0	36.0	294.0
24.0	706.0	38.0	258.0
26.0	604.0	40.0	231.0
28.0	521.0	65.6	60.5
30.0	451.0	100.0	16.9

The conversion curve for the author's instrument employing wire *E* and revolving at a speed of 69 revolutions per minute is shown in the accompanying figure. By the use of wire No. 27 at 58 r.p.m. the viscosity in centipoises could be read off directly.

<sup>1</sup> U. S. Bureau of Standards, Personal Communication.

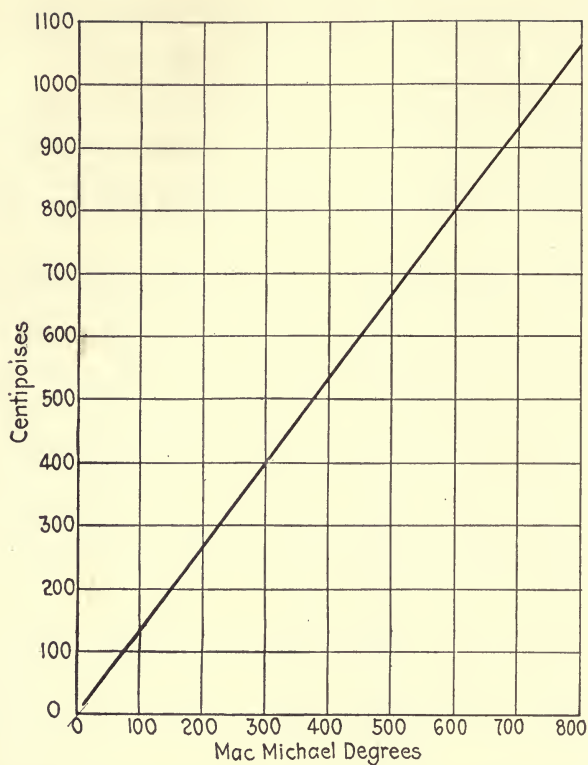

FIG. 118.—Calibration of MacMichael viscosimeter with castor oil (Bureau of Standards *Bull.* 112). Wire E. revolutions 69 per minute. Cp. =  $1\frac{1}{2}$ M.



TABLE 77.—SPECIFIC GRAVITY IN DEGREES BAUMÉ AND TWADDELL LIQUIDS HEAVIER THAN WATER

Degrees Twaddell	Degrees Baumé	Specific gravity	Degrees Twaddell	Degrees Baumé	Specific gravity
0	0.0	1.000	50	28.8	1.250
1	0.7	1.005	51	29.3	1.255
2	1.4	1.010	52	29.7	1.260
3	2.1	1.015	53	30.2	1.265
4	2.7	1.020	54	30.6	1.270
5	3.4	1.025	55	31.1	1.275
6	4.1	1.030	56	31.5	1.280
7	4.7	1.035	57	32.0	1.285
8	5.4	1.040	58	32.4	1.290
9	6.0	1.045	59	32.8	1.295
10	6.7	1.050	60	33.3	1.300
11	7.4	1.055	61	33.7	1.305
12	8.0	1.060	62	34.2	1.310
13	8.7	1.065	63	34.6	1.315
14	9.4	1.070	64	35.0	1.320
15	10.0	1.075	65	35.4	1.325
16	10.6	1.080	66	35.8	1.330
17	11.2	1.085	67	36.2	1.335
18	11.9	1.090	68	36.6	1.340
19	12.4	1.095	69	37.0	1.345
20	13.0	1.100	70	37.4	1.350
21	13.6	1.105	71	37.8	1.355
22	14.2	1.110	72	38.2	1.360
23	14.9	1.115	73	38.6	1.365
24	15.4	1.120	74	39.0	1.370
25	16.0	1.125	75	39.5	1.375
26	16.5	1.130	76	39.8	1.380
27	17.1	1.135	77	40.1	1.385
28	17.7	1.140	78	40.5	1.390
29	18.3	1.145	79	40.8	1.395
30	18.8	1.150	80	41.2	1.400
31	19.3	1.155	81	41.6	1.405
32	19.8	1.160	82	42.0	1.410
33	20.3	1.165	83	42.3	1.415
34	20.9	1.170	84	42.7	1.420
35	21.4	1.175	85	43.1	1.425
36	22.0	1.180	86	43.4	1.430
37	22.5	1.185	87	43.8	1.435
38	23.0	1.190	88	44.1	1.440
39	23.5	1.195	89	44.4	1.445
40	24.0	1.200	90	44.8	1.450
41	24.5	1.205	91	45.1	1.455
42	25.0	1.210	92	45.4	1.460
43	25.5	1.215	93	45.8	1.464
44	26.0	1.220	94	46.1	1.470
45	26.4	1.225	95	46.4	1.475
46	26.9	1.230	96	46.7	1.480
47	27.4	1.235	97	47.1	1.485
48	27.9	1.240	98	47.4	1.490
49	28.4	1.245	99	47.8	1.495

TABLE 77.—(Continued)

Degrees Twaddell	Degrees Baumé	Specific gravity	Degrees Twaddell	Degrees Baumé	Specific gravity
100	48.1	1.500	140	59.5	1.700
101	48.4	1.505	141	59.7	1.705
102	48.7	1.510	142	60.0	1.710
103	49.0	1.515	143	60.2	1.715
104	49.4	1.520	144	60.4	1.720
105	49.7	1.525	145	60.6	1.725
106	50.0	1.530	146	60.9	1.730
107	50.3	1.535	147	61.1	1.735
108	50.6	1.540	148	61.4	1.740
109	50.9	1.545	149	61.6	1.745
110	51.2	1.550	150	61.8	1.750
111	51.5	1.555	151	62.1	1.755
112	51.8	1.560	152	62.3	1.760
113	52.1	1.565	153	62.5	1.765
114	52.4	1.570	154	62.8	1.770
115	52.7	1.575	155	63.0	1.775
116	53.0	1.580	156	63.2	1.780
117	53.3	1.585	157	63.5	1.785
118	53.6	1.590	158	63.7	1.790
119	53.9	1.595	159	64.0	1.795
120	54.1	1.600	160	64.2	1.800
121	54.4	1.605	161	64.4	1.805
122	54.7	1.610	162	64.6	1.810
123	55.0	1.615	163	64.8	1.815
124	55.2	1.620	164	65.0	1.820
125	55.5	1.625	165	65.2	1.825
126	55.8	1.630	166	65.5	1.830
127	56.0	1.635	167	65.7	1.835
128	56.3	1.640	168	65.9	1.840
129	56.6	1.645	169	66.1	1.845
130	56.9	1.650	170	66.3	1.850
131	57.1	1.655	171	66.5	1.855
132	57.4	1.660	...	70.0	1.933
133	57.7	1.665	...	71.0	1.959
134	57.9	1.670	...	72.0	1.986
135	58.2	1.675	...	73.0	2.014
136	58.4	1.680	...	74.0	2.042
137	58.7	1.685	...	75.0	2.071
138	58.9	1.690	...	77.0	2.132
139	59.2	1.695	...	79.0	2.197

Specific gravity =  $\frac{140}{Bé.° + 130}$  for liquids lighter than water.

Specific gravity =  $\frac{145}{145 - Bé.°}$  for liquids heavier than water.

Baumé =  $\frac{140}{Sp. Gr.} - 130$  for liquids lighter than water.

Baumé =  $145 - \frac{145}{Sp. Gr.}$  for liquids heavier than water.

TABLE 78.—SPECIFIC GRAVITIES IN DEGREES BAUMÉ, LIQUIDS LIGHTER THAN WATER

Degrees Baumé	Specific gravity	Degrees Baumé	Specific gravity	Degrees Baumé	Specific gravity
10	1.000	15	0.966	20	0.933
11	0.993	16	0.959	21	0.927
12	0.986	17	0.952	22	0.921
13	0.979	18	0.946	23	0.915
14	0.972	19	0.940	24	0.909
25	0.903	30	0.875	35	0.849
26	0.897	31	0.870	36	0.843
27	0.892	32	0.864	37	0.838
28	0.886	33	0.859	38	0.833
29	0.881	34	0.854	39	0.828
40	0.824	48	0.787	58	0.745
41	0.819	50	0.778	60	0.737
42	0.814	52	0.769	65	0.718
43	0.805	54	0.761	70	0.700
46	0.796	56	0.753	75	0.683

$$\text{Specific gravity} = \frac{\text{Tw.}^\circ + 200}{200}$$

$$\text{Twaddell} = (200 \times \text{sp. gr.}) - 200.$$

1.0 37

TABLE 79.—COMPARISON OF CENTIGRADE AND FAHRENHEIT SCALES

Centi- grade	Fahrenheit	Centi- grade	Fahrenheit	Centi- grade	Fahrenheit	Centi- grade	Fahrenheit
-30	-22.0	10	50.0	50	122.0	90	194.0
-28	-18.4	12	53.6	52	125.6	92	197.6
-26	-14.8	14	57.2	54	129.2	94	201.2
-24	-11.2	16	60.8	56	132.8	96	204.8
-22	-7.6	18	64.4	58	136.4	98	208.4
-20	-4.0	20	68.0	60	140.0	100	212.0
-18	-0.4	22	71.6	62	143.6	105	221.0
-16	3.2	24	75.2	64	147.2	110	230.0
-14	6.8	26	78.8	66	150.8	115	239.0
-12	10.4	28	82.4	68	154.4	120	248.0
-10	14.0	30	86.0	70	158.0	125	257.0
-8	17.6	32	89.6	72	161.6	130	266.0
-6	21.2	34	93.2	74	165.2	135	275.0
-4	24.8	36	96.8	76	168.8	140	284.0
-2	28.4	38	100.4	78	172.4	145	293.0
0	32.0	40	104.0	80	176.0	150	302.0
2	35.6	42	107.6	82	179.6	155	311.0
4	39.2	44	111.2	84	183.2	160	320.0
6	42.8	46	114.8	86	186.8	165	329.0
8	46.4	48	118.4	88	190.4	170	338.0

$$\text{Fahrenheit} = \frac{9C}{5} + 32.$$

$$\text{Centigrade} = \frac{5}{9} (F - 32).$$

TABLE 80.—CONVERSION OF PARTS PER MILLION TO GRAINS PER UNITED STATES AND IMPERIAL GALLONS AND TO PER CENT

Parts per million	Grains per United States gallon	Grains per imperial gallon	Per cent	Parts per million	Grains per United States gallon	Grains per imperial gallon	Per cent
1	0.0583	0.0700	0.0001	40	2.3327	2.8000	0.004
2	0.1166	0.1400	0.0002	50	2.9159	3.5000	0.005
3	0.1749	0.2100	0.0003	60	3.4990	4.2000	0.006
4	0.2332	0.2800	0.0004	70	4.0822	4.9000	0.007
5	0.2916	0.3500	0.0005	80	4.6654	5.6000	0.008
6	0.3499	0.4200	0.0006	90	5.2486	6.3000	0.009
7	0.4082	0.4900	0.0007	100	5.8318	7.0000	0.01
8	0.4665	0.5600	0.0008	200	11.6630	14.0000	0.02
9	0.5248	0.6300	0.0009	300	17.4950	21.0000	0.03
10	0.5831	0.7000	0.001	400	23.3270	28.0000	0.04
20	1.1663	1.4000	0.002	500	29.1590	35.0000	0.05
30	1.7495	2.1000	0.003	1000	58.3180	70.0000	0.1



TABLE 81.—METRIC AND AMERICAN EQUIVALENTS

1 centimeter = 0.3937 inch	1 inch = 2.5400 centimeters
1 meter = 39.37 inches = 1.0936 yards	1 yard = 0.9144 meter
1 meter = 3.20883 feet	1 foot = 0.3048 meter
1 kilometer = 0.62137 mile	1 mile = 1.6093 kilometers
1 square centimeter = 0.1550 square inch	1 square inch = 6.452 square centimeters.
1 square meter = 1.96 square yards	1 square yard = 0.8631 square meter
1 cubic centimeter = 0.0610 cubic inch	1 cubic inch = 16.3872 cubic centimeters
1 cubic meter = 1.308 cubic yards	1 cubic yard = 0.7646 cubic meter
1 liter (1000 c.c.) = 0.908 quart, dry	1 quart dry = 1.101 liters
1 liter = 1.0567 quarts, liquid	1 quart liquid = 0.9463 liter
1 liter = 0.26418 gallon	1 gallon = 3.78533 liters
1 milliliter = 0.033815 U. S. fluid ounce	1 U. S. fluid ounce = 29.573 milliliters.
1 gram = 0.035274 ounce av.	1 ounce av. = 28.350 gram
1 gram = 15.4324 grains	1 grain = 0.064799 grams
1 kilogram (1000 grams) = 2.20462 pounds (av.)	1 pound (av.) = 0.45359 kilogram (453.6 grams)
1 metric ton = 1.1023 English tons	1 English ton = 0.9072 metric ton.

TABLE 82.—SPECIFIC GRAVITY AND PERCENTAGE COMPOSITION OF HYDROCHLORIC, NITRIC AND SULPHURIC ACIDS

Specific gravity	HCl		HNO <sub>3</sub>		H <sub>2</sub> SO <sub>4</sub>	
	Per cent by weight	Grams of acid per 100 c.c.	Per cent by weight	Grams of acid per 100 c.c.	Per cent by weight	Grams of acid per 100 c.c.
1.000	0.16	0.16	0.10	0.10	0.09	0.10
1.005	1.15	1.2	1.00	1.0	0.83	0.80
1.010	2.14	2.2	1.90	1.9	1.57	1.6
1.015	3.12	3.2	2.80	2.8	2.30	2.3
1.020	4.13	4.2	3.70	3.8	3.03	3.1
1.025	5.15	5.3	4.60	4.7	3.76	3.9
1.030	6.15	6.4	5.50	5.7	4.49	4.6
1.035	7.15	7.4	6.38	6.6	5.23	5.4
1.040	8.16	8.5	7.26	7.5	5.96	6.2
1.045	9.16	9.6	8.13	8.5	6.67	7.1
1.050	10.17	10.7	8.99	9.4	7.37	7.7
1.055	11.18	11.8	9.84	10.4	8.07	8.5
1.060	12.19	12.9	10.68	11.3	8.77	9.3
1.065	13.19	14.1	11.51	12.3	9.47	10.2
1.070	14.17	15.2	12.33	13.2	10.19	10.9
1.075	15.16	16.3	13.15	14.1	10.90	11.7
1.080	16.15	17.4	13.95	15.1	11.60	12.5
1.085	17.13	18.6	14.74	16.0	12.30	13.3
1.090	18.11	19.7	15.53	16.9	12.99	14.2
1.095	19.06	20.9	16.32	17.9	13.67	15.0
1.100	20.01	22.0	17.11	18.8	14.35	15.8
1.105	20.97	23.2	17.89	19.8	15.03	16.6
1.110	21.92	24.3	18.67	20.7	15.71	17.5
1.115	22.86	25.5	19.45	21.7	16.36	18.3
1.120	23.82	26.7	20.23	22.7	17.01	19.1
1.125	24.78	27.8	21.00	23.6	17.66	19.9
1.130	25.75	29.1	21.77	24.6	18.31	20.7
1.135	26.70	30.3	22.54	25.6	18.96	21.5
1.140	27.66	31.5	23.31	26.6	19.61	22.3
1.145	28.61	32.8	24.08	27.6	20.26	23.1
1.150	29.57	34.0	24.84	28.6	20.91	23.9
1.155	30.55	35.3	25.60	29.6	21.55	24.8
1.160	31.52	36.6	26.36	30.6	22.19	25.7
1.165	32.49	37.9	27.12	31.6	22.83	26.6
1.170	33.46	39.2	27.88	32.6	23.47	27.5
1.175	34.42	40.4	28.63	33.6	24.12	28.3
1.180	35.39	41.8	29.38	34.7	24.76	29.2
1.185	36.31	43.0	30.13	35.7	25.40	30.1
1.190	37.23	44.3	30.88	36.7	26.04	31.0
1.195	38.16	45.6	31.62	37.8	26.68	31.9
1.200	39.11	46.9	32.36	38.8	27.32	32.8
1.205	.....	.....	33.09	39.9	27.95	33.7
1.210	.....	.....	33.82	40.9	28.58	34.6
1.215	.....	.....	34.55	42.0	29.21	35.5
1.220	.....	.....	35.28	43.0	29.84	36.4
1.225	.....	.....	36.03	44.1	30.48	37.3
1.230	.....	.....	36.78	45.2	31.11	38.2
1.235	.....	.....	37.53	46.3	31.70	39.1
1.240	.....	.....	38.29	47.5	32.28	40.0
1.245	.....	.....	39.05	48.6	32.86	40.9
1.250	.....	.....	39.82	49.8	33.43	41.8
1.255	.....	.....	40.58	50.9	34.00	42.6
1.260	.....	.....	41.34	52.1	34.57	43.5
1.265	.....	.....	42.10	53.3	35.14	44.4
1.270	.....	.....	42.87	54.4	35.71	45.4
1.275	.....	.....	43.64	55.6	36.29	46.2
1.280	.....	.....	44.41	56.8	36.87	47.2
1.285	.....	.....	45.18	58.1	37.45	48.1
1.290	.....	.....	45.95	59.3	38.03	49.0
1.295	.....	.....	46.72	60.5	38.61	50.0
1.300	.....	.....	47.49	61.7	39.19	51.0
1.305	.....	.....	48.26	63.0	39.77	51.9
1.310	.....	.....	49.07	64.3	40.35	52.9
1.315	.....	.....	49.89	65.6	40.93	53.8
1.320	.....	.....	50.71	66.9	41.50	54.8

TABLE 82.—(Continued)

Specific gravity	HCl		HNO <sub>3</sub>		H <sub>2</sub> SO <sub>4</sub>	
	Per cent by weight	Grams of acid per 100 c.c.	Per cent by weight	Grams of acid per 100 c.c.	Per cent by weight	Grams of acid per 100 c.c.
1.325	.....	.....	51.53	68.3	42.08	55.7
1.330	.....	.....	52.37	69.7	42.66	56.7
1.335	.....	.....	53.22	71.0	43.20	57.7
1.340	.....	.....	54.07	72.5	43.74	58.6
1.345	.....	.....	54.93	73.9	44.28	59.6
1.350	.....	.....	55.79	75.3	44.82	60.5
1.355	.....	.....	56.66	76.8	45.35	61.4
1.360	.....	.....	57.57	78.3	45.88	62.4
1.365	.....	.....	58.48	79.8	46.41	63.3
1.370	.....	.....	59.39	81.4	46.94	64.3
1.375	.....	.....	60.30	82.9	47.47	65.3
1.380	.....	.....	61.27	84.6	48.00	66.2
1.385	.....	.....	62.24	86.2	48.53	67.2
1.390	.....	.....	63.23	87.9	49.06	68.2
1.395	.....	.....	64.25	89.6	49.59	69.2
1.400	.....	.....	65.30	91.4	50.11	70.2
1.405	.....	.....	66.40	93.3	50.63	71.1
1.410	.....	.....	67.50	95.2	51.15	72.1
1.415	.....	.....	68.63	97.1	51.66	73.0
1.420	.....	.....	69.80	99.1	52.15	74.0
1.425	.....	.....	70.98	101.1	52.63	75.0
1.430	.....	.....	72.17	103.2	53.11	75.9
1.435	.....	.....	73.39	105.3	53.59	76.9
1.440	.....	.....	74.68	107.5	54.07	77.9
1.445	.....	.....	75.98	109.8	54.55	78.9
1.450	.....	.....	77.28	112.1	55.03	79.8
1.455	.....	.....	78.60	114.4	55.50	80.8
1.460	.....	.....	79.98	116.8	55.97	81.7
1.465	.....	.....	81.42	119.3	56.43	82.7
1.470	.....	.....	82.90	121.9	56.90	83.7
1.475	.....	.....	84.45	124.6	57.37	84.6
1.480	.....	.....	86.05	127.4	57.83	85.6
1.485	.....	.....	87.70	130.2	58.28	86.5
1.490	.....	.....	89.60	133.5	58.74	87.6
1.495	.....	.....	91.60	136.9	59.22	88.5
1.500	.....	.....	94.09	141.1	59.70	89.6
1.505	.....	.....	96.39	145.1	60.18	90.6
1.510	.....	.....	98.10	148.1	60.65	91.6
1.515	.....	.....	99.07	150.1	61.12	92.6
1.520	.....	.....	99.67	151.5	61.59	93.6
1.525	.....	.....	.....	.....	62.06	94.6
1.530	.....	.....	.....	.....	62.53	95.7
1.535	.....	.....	.....	.....	63.00	96.7
1.540	.....	.....	.....	.....	63.43	97.7
1.545	.....	.....	.....	.....	63.85	98.7
1.550	.....	.....	.....	.....	64.26	99.6
1.555	.....	.....	.....	.....	64.67	100.6
1.560	.....	.....	.....	.....	65.08	101.5
1.565	.....	.....	.....	.....	65.49	102.5
1.570	.....	.....	.....	.....	65.90	103.5
1.575	.....	.....	.....	.....	66.30	104.4
1.580	.....	.....	.....	.....	66.71	105.4
1.585	.....	.....	.....	.....	67.13	106.4
1.590	.....	.....	.....	.....	67.59	107.5
1.595	.....	.....	.....	.....	68.05	108.5
1.600	.....	.....	.....	.....	68.51	109.6
1.605	.....	.....	.....	.....	68.97	110.7
1.610	.....	.....	.....	.....	69.43	111.8
1.615	.....	.....	.....	.....	69.89	112.8
1.620	.....	.....	.....	.....	70.32	113.9
1.625	.....	.....	.....	.....	70.74	115.0
1.630	.....	.....	.....	.....	71.16	116.0
1.635	.....	.....	.....	.....	71.57	117.0
1.640	.....	.....	.....	.....	71.99	118.1
1.645	.....	.....	.....	.....	72.40	119.2
1.650	.....	.....	.....	.....	72.82	120.2

TABLE 82.—(Concluded)

Specific gravity	HCl		HNO <sub>3</sub>		H <sub>2</sub> SO <sub>4</sub>	
	Per cent by weight	Grams of acid per 100 c.c.	Per cent by weight	Grams of acid per 100 c.c.	Per cent by weight	Grams of acid per 100 c.c.
1.655	.....	.....	.....	.....	73.23	121.2
1.660	.....	.....	.....	.....	73.64	122.2
1.665	.....	.....	.....	.....	74.07	123.3
1.670	.....	.....	.....	.....	74.51	124.4
1.675	.....	.....	.....	.....	74.97	125.6
1.680	.....	.....	.....	.....	75.42	126.7
1.685	.....	.....	.....	.....	75.86	127.8
1.690	.....	.....	.....	.....	76.30	128.9
1.695	.....	.....	.....	.....	76.73	130.1
1.700	.....	.....	.....	.....	77.17	131.2
1.705	.....	.....	.....	.....	77.60	132.3
1.710	.....	.....	.....	.....	78.04	133.4
1.715	.....	.....	.....	.....	78.48	134.6
1.720	.....	.....	.....	.....	78.92	135.7
1.725	.....	.....	.....	.....	79.36	136.9
1.730	.....	.....	.....	.....	78.90	138.1
1.735	.....	.....	.....	.....	80.24	139.2
1.740	.....	.....	.....	.....	80.68	140.4
1.745	.....	.....	.....	.....	81.12	141.6
1.750	.....	.....	.....	.....	81.56	142.7
1.755	.....	.....	.....	.....	82.00	143.9
1.760	.....	.....	.....	.....	82.44	145.1
1.765	.....	.....	.....	.....	82.88	146.3
1.770	.....	.....	.....	.....	83.32	147.5
1.775	.....	.....	.....	.....	83.90	148.9
1.780	.....	.....	.....	.....	84.50	150.4
1.785	.....	.....	.....	.....	85.10	151.9
1.790	.....	.....	.....	.....	85.70	153.4
1.795	.....	.....	.....	.....	86.30	154.9
1.800	.....	.....	.....	.....	86.90	156.4
1.805	.....	.....	.....	.....	87.60	158.1
1.810	.....	.....	.....	.....	88.30	159.8
1.815	.....	.....	.....	.....	89.05	162.1
1.820	.....	.....	.....	.....	90.05	163.9
1.825	.....	.....	.....	.....	91.00	166.1
1.830	.....	.....	.....	.....	92.10	168.5
1.835	.....	.....	.....	.....	93.43	171.3
1.840	.....	.....	.....	.....	95.60	175.9
1.8405	.....	.....	.....	.....	95.95	176.5
1.8410	.....	.....	.....	.....	97.00	178.6
1.8415	.....	.....	.....	.....	97.70	179.9
1.8410	.....	.....	.....	.....	98.20	180.8
1.8405	.....	.....	.....	.....	98.79	181.6
1.8400	.....	.....	.....	.....	99.20	182.5
1.8395	.....	.....	.....	.....	99.45	183.0
1.8390	.....	.....	.....	.....	99.70	183.4
1.8385	.....	.....	.....	.....	99.95	183.8



TABLE 83.—SPECIFIC GRAVITY AND PERCENTAGE COMPOSITION OF SODIUM AND POTASSIUM HYDROXIDE SOLUTIONS (BY LUNGE)

Specific gravity	Sodium hydroxide		Potassium hydroxide	
	Per cent NaOH	Grams NaOH per liter	Per cent KOH	Grams KOH per liter
1.007	0.61	6	0.9	9
1.014	1.20	12	1.7	17
1.022	2.00	21	2.6	26
1.029	2.70	28	3.5	36
1.036	3.35	35	4.5	46
1.045	4.00	42	5.6	58
1.052	4.64	49	6.4	67
1.060	5.29	56	7.4	78
1.067	5.87	63	8.2	83
1.075	6.55	70	9.2	99
1.083	7.31	79	10.1	109
1.091	8.00	87	10.9	119
1.100	8.68	95	12.0	132
1.108	9.42	104	12.9	143
1.116	10.06	112	13.8	153
1.125	10.97	123	14.8	167
1.134	11.84	134	15.7	178
1.142	12.64	144	16.5	183
1.152	13.55	156	17.6	203
1.162	14.37	167	18.6	216
1.171	15.13	177	19.5	228
1.180	15.91	188	20.5	242
1.190	16.77	200	21.4	255
1.200	17.67	212	22.4	269
1.210	18.58	225	23.3	282
1.220	19.58	239	24.2	295
1.231	20.59	253	25.1	309
1.241	21.42	266	26.1	324
1.252	22.64	283	27.0	338
1.263	23.67	299	28.0	353
1.274	24.81	316	28.9	368
1.285	25.80	332	29.8	385
1.297	26.83	348	30.7	398
1.308	27.80	364	31.8	416
1.320	28.83	381	32.7	432
1.332	29.93	399	33.7	449
1.345	31.22	420	34.9	469
1.357	32.47	441	35.9	487
1.370	33.69	462	36.9	506
1.383	34.96	483	37.8	522
1.397	36.25	506	38.9	543
1.410	37.47	528	39.9	563
1.424	38.80	553	40.9	582
1.438	39.99	575	42.1	605
1.453	41.41	602	43.4	631
1.468	42.83	629	44.6	655
1.483	44.38	658	45.8	679
1.498	46.15	691	47.1	706
1.514	47.60	721	48.3	731
1.530	49.02	750	49.4	756
1.546	.....	...	50.6	779
1.563	.....	...	51.9	811
1.580	.....	...	53.2	840
1.597	.....	...	54.5	870
1.615	.....	...	55.9	905
1.634	.....	...	57.5	940

TABLE 84.—SPECIFIC GRAVITY AND PERCENTAGE COMPOSITION OF AQUA AMMONIA (BY W. C. FERGUSON)

Specific gravity 60°/60°F.	Per cent NH <sub>3</sub>	Specific gravity 60°/60°F.	Per cent NH <sub>3</sub>	Specific gravity 60°/60°F.	Per cent NH <sub>3</sub>
1.0000	0.00	0.9492	13.02	0.9032	27.44
0.9982	0.40	0.9475	13.49	0.9018	27.93
0.9964	0.80	0.9459	13.96	0.9003	28.42
0.9947	1.21	0.9444	14.43	0.8989	28.91
0.9929	1.62	0.9428	14.90	0.8974	29.40
0.9912	2.04	0.9412	15.37	0.8960	29.89
0.9894	2.46	0.9396	15.84	0.8946	30.38
0.9876	2.88	0.9380	16.32	0.8931	30.87
0.9859	3.30	0.9365	16.80	0.8917	31.36
0.9842	3.73	0.9349	17.28	0.8903	31.85
0.9825	4.16	0.9333	17.76	0.8889	32.34
0.9807	4.59	0.9318	18.24	0.8875	32.83
0.9790	5.02	0.9302	18.72	0.8861	33.32
0.9773	5.45	0.9287	19.20	0.8847	33.81
0.9756	5.88	0.9272	19.68	0.8833	34.30
0.9739	6.31	0.9256	20.16	0.8819	34.79
0.9722	6.74	0.9241	20.64	0.8805	35.28
0.9705	7.17	0.9226	21.12	.....	.....
0.9689	7.61	0.9211	21.60	.....	.....
0.9672	8.05	0.9195	22.08	.....	.....
0.9655	8.49	0.9180	22.56	.....	.....
0.9639	8.93	0.9165	23.04	.....	.....
0.9622	9.39	0.9150	23.52	.....	.....
0.9605	9.83	0.9135	24.01	.....	.....
0.9589	10.28	0.9121	24.50	.....	.....
0.9573	10.73	0.9106	24.99	.....	.....
0.9556	11.18	0.9091	25.48	.....	.....
0.9540	11.64	0.9076	25.97	.....	.....
0.9524	12.10	0.9061	26.46	.....	.....
0.9508	12.56	0.9047	26.95	.....	.....

TABLE 85.—TABLE FOR THE CONVERSION OF VOLUME OF NITROGEN TO MILLIGRAMS, FOR USE IN THE ESTIMATION OF AMINO-ACID NITROGEN BY VAN SLYKE'S METHOD  
Milligrams of Amino Nitrogen Corresponding to 1 c.c. of Nitrogen Gas at 11°–30°C.; 728–772 mm. Pressure

t	728	730	732	734	736	738	740	742	744	746	748	750	752	754	756	758	760	762	764	766	768	770	772	t
11°	0.5680	0.5695	0.5510	0.5725	0.5745	0.5760	0.5775	0.5790	0.5805	0.5820	0.5840	0.5855	0.5870	0.5885	0.5900	0.5915	0.5935	0.5950	0.5965	0.5980	0.5995	0.6010	0.6030	11°
12°	0.5655	0.5670	0.5685	0.5700	0.5720	0.5735	0.5750	0.5765	0.5780	0.5795	0.5815	0.5830	0.5845	0.5860	0.5875	0.5890	0.5905	0.5925	0.5940	0.5955	0.5970	0.5985	0.6000	12°
13°	0.5630	0.5645	0.5660	0.5675	0.5695	0.5710	0.5725	0.5740	0.5755	0.5770	0.5785	0.5805	0.5820	0.5835	0.5850	0.5865	0.5880	0.5895	0.5910	0.5930	0.5945	0.5960	0.5975	13°
14°	0.5605	0.5620	0.5635	0.5650	0.5665	0.5680	0.5700	0.5715	0.5730	0.5745	0.5760	0.5775	0.5790	0.5805	0.5825	0.5840	0.5855	0.5870	0.5885	0.5900	0.5915	0.5935	0.5950	14°
15°	0.5580	0.5595	0.5610	0.5625	0.5640	0.5655	0.5670	0.5685	0.5705	0.5720	0.5735	0.5750	0.5765	0.5785	0.5795	0.5810	0.5830	0.5845	0.5860	0.5875	0.5890	0.5905	0.5920	15°
16°	0.5555	0.5570	0.5585	0.5600	0.5615	0.5630	0.5645	0.5660	0.5675	0.5690	0.5710	0.5725	0.5740	0.5755	0.5770	0.5785	0.5800	0.5815	0.5830	0.5850	0.5865	0.5880	0.5895	16°
17°	0.5525	0.5540	0.5555	0.5575	0.5590	0.5605	0.5620	0.5635	0.5650	0.5665	0.5680	0.5695	0.5710	0.5730	0.5745	0.5760	0.5775	0.5790	0.5805	0.5820	0.5825	0.5850	0.5865	17°
18°	0.5500	0.5515	0.5530	0.5545	0.5560	0.5580	0.5595	0.5610	0.5625	0.5640	0.5655	0.5670	0.5685	0.5700	0.5715	0.5730	0.5745	0.5765	0.5780	0.5795	0.5810	0.5825	0.5840	18°
19°	0.5475	0.5490	0.5505	0.5520	0.5535	0.5550	0.5565	0.5580	0.5595	0.5610	0.5630	0.5645	0.5660	0.5675	0.5690	0.5705	0.5720	0.5735	0.5750	0.5765	0.5780	0.5795	0.5810	19°
20°	0.5445	0.5460	0.5475	0.5495	0.5510	0.5525	0.5540	0.5555	0.5570	0.5585	0.5600	0.5615	0.5630	0.5645	0.5660	0.5675	0.5690	0.5705	0.5725	0.5740	0.5755	0.5770	0.5785	20°
21°	0.5420	0.5435	0.5450	0.5465	0.5480	0.5495	0.5510	0.5525	0.5540	0.5555	0.5575	0.5590	0.5605	0.5620	0.5635	0.5650	0.5665	0.5680	0.5695	0.5710	0.5725	0.5740	0.5755	21°
22°	0.5395	0.5410	0.5425	0.5440	0.5455	0.5470	0.5485	0.5500	0.5515	0.5530	0.5545	0.5560	0.5575	0.5590	0.5605	0.5620	0.5635	0.5650	0.5665	0.5680	0.5695	0.5715	0.5730	22°
23°	0.5365	0.5380	0.5395	0.5410	0.5425	0.5440	0.5455	0.5470	0.5485	0.5500	0.5515	0.5530	0.5545	0.5560	0.5575	0.5595	0.5610	0.5625	0.5640	0.5655	0.5670	0.5685	0.5700	23°
24°	0.5335	0.5350	0.5365	0.5380	0.5400	0.5415	0.5430	0.5445	0.5460	0.5475	0.5490	0.5505	0.5520	0.5535	0.5550	0.5565	0.5580	0.5595	0.5610	0.5625	0.5640	0.5655	0.5670	24°
25°	0.5310	0.5325	0.5340	0.5355	0.5370	0.5385	0.5400	0.5415	0.5430	0.5445	0.5460	0.5475	0.5490	0.5505	0.5520	0.5535	0.5550	0.5565	0.5580	0.5595	0.5610	0.5625	0.5640	25°
26°	0.5260	0.5295	0.5310	0.5325	0.5340	0.5355	0.5370	0.5385	0.5400	0.5415	0.5430	0.5445	0.5460	0.5475	0.5490	0.5505	0.5520	0.5535	0.5550	0.5565	0.5580	0.5595	0.5610	26°
27°	0.5250	0.5265	0.5280	0.5295	0.5310	0.5325	0.5340	0.5355	0.5370	0.5385	0.5400	0.5415	0.5430	0.5445	0.5460	0.5475	0.5490	0.5505	0.5520	0.5535	0.5550	0.5565	0.5580	27°
28°	0.5220	0.5235	0.5250	0.5265	0.5280	0.5295	0.5310	0.5325	0.5340	0.5355	0.5370	0.5385	0.5400	0.5415	0.5430	0.5445	0.5460	0.5475	0.5490	0.5505	0.5520	0.5535	0.5550	28°
29°	0.5195	0.5210	0.5220	0.5235	0.5250	0.5265	0.5280	0.5295	0.5310	0.5325	0.5340	0.5355	0.5370	0.5385	0.5400	0.5415	0.5430	0.5445	0.5460	0.5475	0.5490	0.5505	0.5520	29°
30°	0.5160	0.5175	0.5190	0.5205	0.5220	0.5235	0.5250	0.5265	0.5280	0.5295	0.5310	0.5325	0.5340	0.5355	0.5370	0.5385	0.5400	0.5415	0.5430	0.5445	0.5460	0.5475	0.5490	30°
t	728	730	732	734	736	738	740	742	744	746	748	750	752	754	756	758	760	762	764	766	768	770	772	t

VAN SLYKE, *J. Biol. Chem.*, xii, No. 2. The Quantitative Determination of Amino Group II.

TABLE 86.—THE CHEMICAL ELEMENTS AND THEIR ATOMIC WEIGHTS  
(Compiled by the International Committee on Atomic Weights)  
Corrected to 1921

Name	Symbol	Atomic weight	Name	Symbol	Atomic weight
Aluminum.....	Al	27.1	Molybdenum.....	Mo	96.0
Antimony.....	Sb	120.2	Neodymium.....	Nd	144.3
Argon.....	A	39.9	Neon.....	Ne	20.2
Arsenic.....	As	74.96	Nickel.....	Ni	58.68
Barium.....	Ba	137.37	Niton.....	Nt	222.4
Bismuth.....	Bi	208.0	Nitrogen.....	N	14.008
Boron.....	B	10.9	Osmium.....	Os	190.9
Bromine.....	Br	79.92	Oxygen.....	O	16.00
Cadmium.....	Cd	112.40	Palladium.....	Pd	106.7
Calcium.....	Ca	40.07	Phosphorus.....	P	31.04
Carbon.....	C	12.005	Platinum.....	Pt	195.2
Cerium.....	Ce	140.25	Potassium.....	K	39.10
Cesium.....	Cs	132.81	Praesodymium.....	Pr	140.9
Chlorine.....	Cl	35.46	Radium.....	Ra	226.0
Chromium.....	Cr	52.0	Rhodium.....	Rh	102.9
Cobalt.....	Co	58.97	Rubidium.....	Rb	85.45
Columbium.....	Cb	93.1	Ruthenium.....	Ru	101.7
Copper.....	Cu	63.57	Samarium.....	Sa	150.4
Dysprosium.....	Dy	162.5	Scandium.....	Sc	45.1
Erbium.....	Er	167.7	Selenium.....	Se	79.2
Europium.....	Eu	152.0	Silicon.....	Si	28.3
Fluorine.....	F	19.0	Silver.....	Ag	107.88
Gadolinium.....	Gd	157.3	Sodium.....	Na	23.00
Gallium.....	Ga	70.1	Strontium.....	Sr	87.63
Germanium.....	Ge	72.5	Sulphur.....	S	32.06
Glucinum.....	Gl	9.1	Tantalum.....	Ta	181.5
Gold.....	Au	197.2	Tellurium.....	Te	127.5
Helium.....	He	4.00	Terbium.....	Tb	159.2
Holmium.....	Ho	163.5	Thallium.....	Tl	204.0
Hydrogen.....	H	1.008	Thorium.....	Th	232.15
Indium.....	In	114.8	Thulium.....	Tm	168.5
Iodine.....	I	126.92	Tin.....	Sn	118.7
Iridium.....	Ir	193.1	Titanium.....	Ti	48.1
Iron.....	Fe	55.84	Tungsten.....	W	184.0
Krypton.....	Kr	82.92	Uranium.....	U	238.2
Lanthanum.....	La	139.0	Vanadium.....	V	51.0
Lead.....	Pb	207.20	Xenon.....	Xe	130.2
Lithium.....	Li	6.94	Ytterbium.....	Yb	173.5
Lutecium.....	Lu	175.0	Yttrium.....	Yt	89.33
Magnesium.....	Mg	24.32	Zinc.....	Zn	65.37
Manganese.....	Mn	54.93	Zirconium.....	Zr	90.6
Mercury.....	Hg	200.6			



TABLE 87.—LOGARITHMS OF NUMBERS

Natural numbers	0	1	2	3	4	5	6	7	8	9	Proportional parts								
											1	2	3	4	5	6	7	8	9
10	0000	0043	0086	0128	0170	0212	0253	0294	0334	0374	4	8	12	17	21	25	29	33	37
11	0414	0453	0492	0531	0569	0607	0645	0682	0719	0755	4	8	11	15	19	23	26	30	34
12	0792	0828	0864	0899	0934	0969	1004	1038	1072	1106	3	7	10	14	17	21	24	28	31
13	1139	1173	1206	1239	1271	1303	1335	1367	1399	1430	3	6	10	13	16	19	23	26	29
14	1461	1492	1523	1553	1584	1614	1644	1673	1703	1732	3	6	9	12	15	18	21	24	27
15	1761	1790	1818	1847	1875	1903	1931	1959	1987	2014	3	6	8	11	14	17	20	22	25
16	2041	2068	2095	2122	2148	2175	2201	2227	2253	2279	3	5	8	11	13	16	18	21	24
17	2304	2330	2355	2380	2405	2430	2455	2480	2504	2529	2	5	7	10	12	15	17	20	22
18	2553	2577	2601	2625	2648	2672	2695	2718	2742	2765	2	5	7	9	12	14	16	19	21
19	2788	2810	2833	2856	2878	2900	2923	2945	2967	2989	2	4	7	9	11	13	16	18	20
20	3010	3032	3054	3075	3096	3118	3139	3160	3181	3201	2	4	6	8	11	13	15	17	19
21	3222	3243	3263	3284	3304	3324	3345	3365	3385	3404	2	4	6	8	10	12	14	16	18
22	3424	3444	3464	3483	3502	3522	3541	3560	3579	3598	2	4	6	8	10	12	14	15	17
23	3617	3636	3655	3674	3692	3711	3729	3747	3766	3784	2	4	5	7	9	11	13	15	17
24	3802	3820	3838	3856	3874	3892	3909	3927	3945	3962	2	4	5	7	9	11	12	14	16
25	3979	3997	4014	4031	4048	4065	4082	4099	4116	4133	2	3	5	7	9	10	12	14	15
26	4150	4166	4183	4200	4216	4232	4249	4265	4281	4298	2	3	5	7	8	10	11	13	15
27	4314	4330	4346	4362	4378	4393	4409	4425	4440	4456	2	3	5	6	8	9	11	13	14
28	4472	4487	4502	4518	4533	4548	4564	4579	4594	4609	2	3	5	6	8	9	11	12	14
29	4624	4639	4654	4669	4683	4698	4713	4728	4742	4757	1	3	4	6	7	9	10	12	13
30	4771	4786	4800	4814	4829	4843	4857	4871	4886	4900	1	3	4	6	7	9	10	11	13
31	4914	4928	4942	4955	4969	4983	4997	5011	5024	5038	1	3	4	6	7	8	10	11	12
32	5051	5065	5079	5092	5105	5119	5132	5145	5159	5172	1	3	4	5	7	8	9	11	12
33	5185	5198	5211	5224	5237	5250	5263	5276	5289	5302	1	3	4	5	6	8	9	10	12
34	5315	5328	5340	5353	5366	5378	5391	5403	5416	5428	1	3	4	5	6	8	9	10	11
35	5441	5453	5465	5478	5490	5502	5514	5527	5539	5551	1	2	4	5	6	7	9	10	11
36	5563	5575	5587	5599	5611	5623	5635	5647	5658	5670	1	2	4	5	6	7	8	10	11
37	5682	5694	5705	5717	5729	5740	5752	5763	5775	5786	1	2	3	5	6	7	8	9	10
38	5798	5809	5821	5832	5843	5855	5866	5877	5888	5899	1	2	3	5	6	7	8	9	10
39	5911	5922	5933	5944	5955	5966	5977	5988	5999	6010	1	2	3	4	5	7	8	9	10
40	6021	6031	6042	6053	6064	6075	6085	6096	6107	6117	1	2	3	4	5	6	8	9	10
41	6128	6138	6149	6160	6170	6180	6191	6201	6212	6222	1	2	3	4	5	6	7	8	9
42	6232	6243	6253	6263	6274	6284	6294	6304	6314	6325	1	2	3	4	5	6	7	8	9
43	6335	6345	6355	6365	6375	6385	6395	6405	6415	6425	1	2	3	4	5	6	7	8	9
44	6435	6444	6454	6464	6474	6484	6493	6503	6513	6522	1	2	3	4	5	6	7	8	9
45	6532	6542	6551	6561	6571	6580	6590	6599	6609	6618	1	2	3	4	5	6	7	8	9
46	6628	6637	6646	6656	6665	6675	6684	6693	6702	6712	1	2	3	4	5	6	7	8	9
47	6721	6730	6739	6749	6758	6767	6776	6785	6794	6803	1	2	3	4	5	6	7	8	9
48	6812	6821	6830	6839	6848	6857	6866	6875	6884	6893	1	2	3	4	5	6	7	8	9
49	6902	6911	6920	6928	6937	6946	6955	6964	6972	6981	1	2	3	4	5	6	7	8	9
50	6990	6998	7007	7016	7024	7033	7042	7050	7059	7067	1	2	3	3	4	5	6	7	8
51	7076	7084	7093	7101	7110	7118	7126	7135	7143	7152	1	2	3	3	4	5	6	7	8
52	7160	7168	7177	7185	7193	7202	7210	7218	7226	7235	1	2	2	3	4	5	6	7	7
53	7243	7251	7259	7267	7275	7284	7292	730	7308	7316	1	2	2	3	4	5	6	6	7
54	7324	7332	7340	7348	7356	7364	7372	7380	7388	7396	1	2	2	3	4	5	6	6	7

TABLE 87.—(Concluded)

Natural numbers	0	1	2	3	4	5	6	7	8	9	Proportional parts								
											1	2	3	4	5	6	7	8	9
55	7404	7412	7419	7427	7435	7443	7451	7459	7466	7474	1	2	2	3	4	5	5	6	7
56	7482	7490	7497	7505	7513	7520	7528	7536	7543	7551	1	2	2	3	4	5	5	6	7
57	7559	7566	7574	7582	7589	7597	7604	7612	7619	7627	1	2	2	3	4	5	5	6	7
58	7634	7642	7649	7657	7664	7672	7679	7686	7694	7701	1	1	2	3	4	4	5	6	7
59	7709	7716	7723	7731	7738	7745	7752	7760	7767	7774	1	1	2	3	4	4	5	6	7
60	7782	7789	7796	7803	7810	7818	7825	7832	7839	7846	1	1	2	3	4	4	5	6	6
61	7853	7860	7868	7875	7882	7889	7896	7903	7910	7917	1	1	2	3	4	4	5	6	6
62	7924	7931	7938	7945	7952	7959	7966	7973	7980	7987	1	1	2	3	3	4	4	5	6
63	7993	8000	8007	8014	8021	8028	8035	8041	8048	8055	1	1	2	3	3	4	4	5	6
64	8062	8069	8075	8082	8089	8096	8102	8109	8116	8122	1	1	2	3	3	4	4	5	6
65	8129	8136	8142	8149	8156	8162	8169	8176	8182	8189	1	1	2	3	3	4	4	5	6
66	8195	8202	8209	8215	8222	8228	8235	8241	8248	8254	1	1	2	3	3	4	4	5	6
67	8261	8267	8274	8280	8287	8293	8299	8306	8312	8319	1	1	2	3	3	4	4	5	6
68	8325	8331	8338	8344	8351	8357	8363	8370	8376	8382	1	1	2	3	3	4	4	5	6
69	8388	8395	8401	8407	8414	8420	8426	8432	8439	8445	1	1	2	2	3	4	4	5	6
70	8451	8457	8463	8470	8476	8482	8488	8494	8500	8506	1	1	2	2	3	4	4	5	6
71	8513	8519	8525	8531	8537	8543	8549	8555	8561	8567	1	1	2	2	3	4	4	5	5
72	8573	8579	8585	8591	8597	8603	8609	8615	8621	8627	1	1	2	2	3	4	4	5	5
73	8633	8639	8645	8651	8657	8663	8669	8675	8681	8686	1	1	2	2	3	4	4	5	5
74	8692	8698	8704	8710	8716	8722	8727	8733	8739	8745	1	1	2	2	3	4	4	5	5
75	8751	8756	8762	8768	8774	8779	8785	8791	8797	8802	1	1	2	2	3	4	4	5	5
76	8808	8814	8820	8825	8831	8837	8842	8848	8854	8859	1	1	2	2	3	4	4	5	5
77	8865	8871	8876	8882	8887	8893	8899	8904	8910	8915	1	1	2	2	3	4	4	5	5
78	8921	8927	8932	8938	8943	8949	8954	8960	8965	8971	1	1	2	2	3	4	4	5	5
79	8976	8982	8987	8993	8998	9004	9009	9015	9020	9026	1	1	2	2	3	4	4	5	5
80	9031	9036	9042	9047	9053	9058	9063	9069	9074	9079	1	1	2	2	3	4	4	5	5
81	9085	9090	9096	9101	9106	9112	9117	9122	9128	9133	1	1	2	2	3	4	4	5	5
82	9138	9143	9149	9154	9159	9165	9170	9175	9180	9186	1	1	2	2	3	4	4	5	5
83	9191	9196	9201	9206	9212	9217	9222	9227	9232	9238	1	1	2	2	3	4	4	5	5
84	9243	9248	9253	9258	9263	9269	9274	9279	9284	9289	1	1	2	2	3	4	4	5	5
85	9294	9299	9304	9309	9315	9320	9325	9330	9335	9340	1	1	2	2	3	4	4	5	5
86	9345	9350	9355	9360	9365	9370	9375	9380	9385	9390	1	1	2	2	3	4	4	5	5
87	9395	9400	9405	9410	9415	9420	9425	9430	9435	9440	0	1	1	2	2	3	4	4	4
88	9445	9450	9455	9460	9465	9469	9474	9479	9484	9489	0	1	1	2	2	3	4	4	4
89	9494	9499	9504	9509	9513	9518	9523	9528	9533	9538	0	1	1	2	2	3	4	4	4
90	9542	9547	9552	9557	9562	9566	9571	9576	9581	9586	0	1	1	2	2	3	4	4	4
91	9590	9595	9600	9605	9609	9614	9619	9624	9628	9633	0	1	1	2	2	3	4	4	4
92	9638	9643	9647	9652	9657	9661	9666	9671	9675	9680	0	1	1	2	2	3	4	4	4
93	9685	9689	9694	9699	9703	9708	9713	9717	9722	9727	0	1	1	2	2	3	4	4	4
94	9731	9736	9741	9745	9750	9754	9759	9763	9768	9773	0	1	1	2	2	3	4	4	4
95	9777	9782	9786	9791	9795	9800	9805	9809	9814	9818	0	1	1	2	2	3	4	4	4
96	9823	9827	9832	9836	9841	9845	9850	9854	9859	9863	0	1	1	2	2	3	4	4	4
97	9868	9872	9877	9881	9886	9890	9894	9899	9903	9908	0	1	1	2	2	3	4	4	4
98	9912	9917	9921	9926	9930	9934	9939	9943	9948	9952	0	1	1	2	2	3	4	4	4
99	9956	9961	9965	9969	9974	9978	9983	9987	9991	9996	0	1	1	2	2	3	4	4	4

## SUBJECT INDEX

### A

- Abrasive wheels, 545  
Adamkiewicz reaction, 47  
Adhesive strength, 411, 517-538  
    conditions affecting, 517-526  
    methods of testing, 526-534  
    significance in evaluation,  
    493, 495  
Adsorption, 314  
Agar-agar, 127  
Alanine, 21, 35, 36, 65  
Albumin, 280  
Albuminoids, 19, 20, 73, 83, 85, 86  
Albumoses, 469  
Alcohol number, 249  
    precipitation, 463-464, 471  
Aluminum oxide, 440-441  
Alum-treated glues, 190, 191, 198  
Alutes, 571  
Amicrons, 161  
Amide nitrogen, 39, 40  
Amine nitrogen, 38  
Amino-acids, 21-23  
    apparatus, 31-33  
    calculation of molecular weight  
    from, 112-113  
    condensation of, 222  
    conversion table for, 621  
    description, 21  
    determination, 25-28, 448-449,  
    451-452  
    distribution in keratins, 65  
    enumeration and formulas,  
    21-23  
    estimation, 28-29  
    formaldehyde titration, 30  
    in proteins, 36  
    nitrogen in free groups, 221  
    nitrous acid method, 30-34  
Amino-acids, separation, 34-37  
    synthesis, 18  
    Van Slyke distribution, 38-45  
Amino nitrogen, 38, 39, 40, 42  
Ammonia nitrogen, 36, 39, 40  
Ammonium hydroxide, 620  
Amphoterisis, 219-223  
Amyloid, 76-77, 78-80  
Analysis of ash, 425-463  
    gelatin, 433-448  
    organic, 448-450  
    proximate, 429-433  
    sampling, 427-429  
    special tests, 450-456  
    traces of metals, 456-463  
Animal gum, 71  
Antiseptics, 291  
Arginine, 22, 38, 40, 41, 65  
Arsine, 457-459  
Artificial ivory, 546  
    leather, 549  
    silk, 549  
Ash analysis, 433-448  
    aluminum oxide, 440-441  
    barium oxide, 444  
    calcium oxide, 441-442  
    chloride, 447-448  
    ferric oxide, 449-441  
    lead oxide, 444  
    magnesium oxide, 442-443  
    phosphoric acid, 434-440  
    potassium oxide, 444-446  
    silica, 434  
    sodium oxide, 444-446  
    sulphate, 447  
    zinc oxide, 444  
Ash-free gelatin, 102  
    significance, 289  
Aspartic acid, 22, 35, 36, 39, 65  
Atmidkeratin, 64

- Atmidkeratose, 64  
 Atomic weights, 622  
 Autoclaves, 303, 314  
 Avogadro's constant, 200  
   law, 101  
 Azotobacter, 15
- B
- Bacteria, action on gelatin, 60-61  
   decomposition of glue by, 515-517  
   in gelatin and ice cream, 566  
   in hide stock, 280-281, 313  
 Barium oxide, 444  
 Barrel mill, 278  
 Basic nitrogen, 38  
 Baumé degrees, 611-613  
 Beating engine, 278, 313  
 Bergman process, 306, 317  
 Bibliography, fish glues, 365-366  
   glue and gelatin manufacture, 313-317  
   U. S. patents on casein adhesives, 340-344  
 Billiard balls, 546  
 Biuret reaction, 45  
 Blood albumin, 288, 344  
   glue, 344-348  
     application, 345-347  
     comparison with other glues, 362-363  
     dry glue process, 347-348  
     formula for making, 345  
     preparation, 345  
     press for joining, 346  
 Boiling point, 106-107, 110  
 Bone glue, 300-303  
 Bones, 87-88  
   collagen from, 51  
   composition, 88  
   of inorganic portion, 87  
   degreasing, 300-303  
   glue from, 2, 4, 6, 316-317  
   leaching, 303-306  
   marrow of, 87  
 Bone tankage, 307  
 Bookbinding, 537  
 Breman blue, 540
- Bristles, 64  
 Bromine precipitation, 472-473  
 Brownian movement, 109, 124  
 Buffer action, 587
- C
- Calcium oxide, 441-442  
 Calomel electrode, 588  
 Calsomine, 544-545  
 Cambon's fusiometer, 405-406  
 Caprine, 21, 36  
 Capsules, 570  
 Carbohydrates, 15  
 Cartilage, 70, 86  
 Cartons, 536  
 Casein, acid coagulation method  
   for, 321  
   acidity, 331-332  
   ash, 330-331  
   borax solubility test, 332-333  
   color, 328  
   electrolysis, 228  
   fat, 329-330  
   fineness, 328-329  
   government specifications for, 325  
   grain curd method for, 322-324  
   influence of method of manufacture, 325-327  
   lactic acid method for, 320-321  
   manufacture, 320-325  
   methods of analysis and testing, 327-333  
   moisture, 329  
   nitrogen, 331  
     of free amino groups, 221  
   odor, 328  
   rennet coagulation method for, 321-322  
   sampling for analysis, 328  
   test in size, 483-486  
 Casein glue, 318-344  
   application, 337-339  
   ash content, 326  
   bibliography of U. S. patents on, 340-344  
   comparison with other glues, 362-363



- Casein glue, dry-mix, 333-337  
 formulas for making, 334-336  
 life, 326  
 mixer for, 337-338  
 properties, 333-337  
 sodium fluoride in, 336-337,  
 343-344  
 strength and water-resis-  
 tance, 339-340  
 wet-mix, 333-337
- Caseinogen, 36, 38, 123
- Castor oil, 609
- Cellulose, 49  
 filters, 288
- Centigrade-Fahrenheit table, 614
- Charcoal filters, 288
- Chitin, 49
- Chitinoids, 20
- Chloride, 447-448
- Chlorine precipitation, 472
- Chocolate, 480
- Chondrigin, 73-74
- Chondrin, 73-74, 68-80
- Chondroalbuminoid, 86
- Chondroitin acid, 69-70, 73, 86
- Chondroitin, 70
- Chondromucoid, 70, 73, 86
- Chondroprotein, 70-71
- Chondrosin, 70
- Chum, 359
- Coagulation, 239
- Coefficient of diffusion, 92  
 of penetration, 170
- Coffee, 481
- Collagen, 49-52  
 classification, 20  
 derivation, 1  
 elementary composition, 50  
 formula for, 49  
 from cartilage, 86  
 from connective tissue, 85  
 from fish scales, 77, 78, 88  
 from ossein, 87  
 from skin, 82  
 hydrolysis, 51  
 preparation, 51  
 properties, 51  
 reaction with enzymes, 51-52  
 relation to chondrigin, 73
- Collodion membranes, 97
- Colloid, classification, 161-163  
 definition, 160  
 derivation, 1, 17
- Colloidal electrolytes, 266
- Color comparator, 606
- Color reactions, 42-47
- Colorimetric determination, 599-606
- Commercial gelatin, 571-576
- Composition cork, 546
- Conductivity, 249, 257, 289, 313
- Cone mill, 278
- Coney stock, 272
- Conjugated proteins, 69
- Connective tissue, 82-86
- Copper, 459-460
- Coriin, 84
- Corium, 79, 82, 84
- Country bone, 273, 275
- Court plaster, 571
- Crazed glue, 422-424
- Cream, 477-478
- Crystalline liquide, 138
- Cystine, 22, 35-38, 40, 41, 65-67
- D
- Degree of dispersion, 162
- Dental caries, 72
- Depilation, 280, 313, 314
- Desiccation of hide stock, 277
- Detection of gelatin or glue, 470-486  
 in meat and meat products,  
 470-477  
 in milk, cream and ice  
 cream, 477-478  
 in other food products,  
 478-483  
 in size, 483-486
- Deuteroalbuminose, 123
- Deuteroelastose, 68
- Dextrin, 123
- Dialysis, 95-97
- Diffusion, 91-95  
 thimbles, 96
- Dineric interface, 214
- Disinfection of hides, 313, 314
- Dispersed phase, 162
- Dispersion medium, 162

- Distinction between gelatin and glue, 62
- Donnan equilibrium, 128-132, 158-159, 168, 184-185
- Doublet, 135
- Drying alleys, 294-300
- E
- Edestine, 38, 43, 221
- Edible gelatin, 556-571
- Egg albumin, 38, 92, 106, 115, 123, 133, 227, 288
- globulin, 123, 134
- membrane, 64, 65
- Elasticity, 411-413
- Elastin, 36, 67-69, 78-80, 85
- Electro-metallurgic process, 550
- Electrometric determination, 587-599
- Emery paper, 545
- Emulsification test, 482
- Emulsifying agent, 212-218, 567-569
- Emulsin, 92
- Emulsions, 212-218
- Emulsoid, 163, 203
- Equivalent weight, 108
- Erepsin, 24
- Estimation of gelatin, 463-470
- alcoholic precipitation, 463-464
- indirect methods, 467-468
- picric acid precipitation, 466-467
- salt precipitation, 468-470
- tannin precipitation, 464-466
- Evaluation, 487-505
- Evaporation, 4, 290-292, 315
- Eye, 76
- F
- Fahrenheit-Centigrade table, 614
- Fat, 15, 455-456
- extractor, 301
- Feathers, 64-65
- Feeding stuffs, 481
- Ferric oxide, 440-441
- Fibrin, 182-183
- Fibroids, 20, 36, 43
- Fining, 355, 569
- Fischer's esterification method, 35, 449-450
- Fish gelatin, 349
- glue, 356-366
- bibliography, 365-366
- comparison with other glues, 362-363
- composition, 361-364, 435
- constitution, 28
- hygroscopicity, 360
- manufacture, 358-359
- preparation, 4
- production, 6-7
- properties, 364-365
- raw materials, 357-358
- tests for quality, 359-361
- uses, 365
- Van Slyke determination, 43, 46
- Fixed acids, 451
- Flake glue, 298
- Fleshings, 272, 274
- Fluorides, 336-337, 343-344
- Foam, 416-418, 501
- Foamite, 554
- Foils, 571
- Formaldehyde, action on gelatin, 57-58, 570
- on glue, 190, 192, 198, 199
- determination, 454
- in water-resistant glues, 318
- precipitation by, 473
- titration, 30
- Formo-gelatin, 570
- Free mineral acids, 451
- organic acids, 451
- Freezing point, 106-107
- Fibrinogen, 229
- Frosted glass, 538
- Fruit products, 478
- Fur, 64
- G
- Gamboge, 201
- Gayley dry-blast process, 298, 316
- Gelatin, action of enzymes on, 59

- Gelatin, action of halogens on, 56-57  
  of oxidizing agents on, 59  
  alcohol number of, 154  
  amino-acid composition of, 36  
  analysis, 425-463  
  as a culture medium, 474-475  
  as a food, 556-558  
  as a glaze on coffee, 481  
  as an emulsifying agent, 567-569  
  ash-free, 102  
  bacteria in, 566  
  bibliography on manufacture, 313-317  
  boiling point, 106-107  
  bromine precipitation, 473  
  brownian movement, 109  
  by-products, 307-313  
  cells for ultrafiltration, 575-576  
  change in viscosity with time, 149-151  
  colloidal phenomena, 576-578  
  color reactions, 60  
  combination with acids, 256  
  combining capacity, 110-112  
  commercial, 571-576  
  constitution, 28-29, 58-60  
  crystals, 143  
  decomposition by bacteria, 60-61  
  derivation, 1  
  detection, 470-486  
  dialysis, 95-97  
  diffusion, 91  
  distinction from glue, 62, 502  
  edible, 4, 556-571  
  elementary composition, 50, 111  
  emulsification test, 482  
  estimation, 463-470  
  in papers, 56  
  exports, 5-8, 11-12  
  foam, 153  
  foils, 571  
  formulas, 49, 111, 112  
  freezing point, 106-107  
  gelation, 164-186  
  gold number, 121-123  
  Hausmann numbers, 38  
  hydration, 49
- Gelatin, hydrolysis, 25  
  imports, 5-8, 10-11  
  in analytical procedures, 576  
  in chocolate, 480  
  in feeding stuffs, 481  
  in fining, 569  
  in food products, 567  
  in fruits and fruit products, 478  
  in glues, 465  
  in gums, 480  
  in ice cream, 561-567  
  in meat and meat products, 470-477  
  in milk, cream and ice cream, 477-378  
  in paper, 486  
  in pharmaceutical preparations, 569-571  
  in photography and photolithography, 571-574  
  index of refraction, 119-121  
  inorganic composition, 435  
  jelly strength, 154  
  manufacture, 306-307  
  melting point, 54  
  molecular weight, 107-114  
  mutarotation, 156-157  
  nitrogen in free amino groups, 221  
  optical rotation, 116-119  
  osmosis, 97-104  
  osmotic pressure, 98-99  
  physico-chemical properties, 91-132  
  preparation, 61  
  production, 5-9  
  properties, 52-55, 78-80  
  protective action, 123, 558-567  
  purification, 61  
  raw materials, 7  
  reactions, 56  
  Rontgen photograph, 144  
  size of ultramicros, 125  
  sol-gel equilibrium, 148, 151-152, 207, 211-212  
  solubility, 55  
  of salts in, 54  
  solution, 164-186  
  specific rotation, 116-117

- Gelatin, structure, 132-159  
   sulphur dioxide in, 453  
   surface tension, 114-116  
   swelling, 153, 164-186  
   testing, 369-424  
   turbidity, 154  
   Tyndall effect, 123-128  
   ultramicroscopy, 123-128  
   Van Slyke determination, 43-46  
   vapor pressure, 104-105  
   veneers, 550  
   viscosity, 153, 186-212  
 Gelatinizing agents, 478-479  
 Gibbs' theorem, 115  
 Gliadin, 36, 38, 43, 221  
 Glucosamine, 70  
 Glue, adhesive, 517-538  
   analysis, 425-463  
   application, 536-538  
   bacterial decomposition, 515-517  
   bibliography on manufacture, 313-317  
   binding agent, 545-547  
   by-products, 307-313  
   colloidal gel, 547-550  
   comparison of different glues, 362-363  
   constitution, 28  
   course through plant, 312  
   derivation, 1  
   detection, 470-486  
   distinction from gelatin, 62, 502  
   effect of pressure, 523  
   estimation, 463-470  
   exports, 5-8, 11-12  
   extraction apparatus, 286, 314  
   gelatin content, 465  
   gold number, 123  
   handling, 506-517  
   imports, 5-8, 10-11  
   in oils, 486  
   inorganic composition, 435  
   losses from overheating, 510-515  
   manufacture, 271-303  
   prices, 7, 12  
   production, 5, 7-9  
   protective action, 550  
   raw materials, 7, 271-277  
   selection for service, 534-536  
   sizing agent, 538-545  
   testing, 369-424  
   uses and applications, 506-554  
   Van Slyke composition, 43  
     determination, 43-46  
   Glue room economy and technology, 506-510  
   Glutamic acid, 22, 35, 36, 39, 65  
   Glutem, 1  
   Glutenin, 38, 43  
   Glycine, 21, 35, 36, 65  
   Glycoproteins, 69, 123  
   Glycuronic acid, 70  
   Gold number, 121-123  
   Grade designation, 502-504  
   Grain curd casein, 322-324  
   Grease, 308-309, 418-419, 455-456, 501, 541  
   Green bone, 273, 303  
   Grillo-Schroeder process, 303, 317  
   Gum arabic, 165  
   Gum tragacanth, 164  
   Gums, 480
- H
- Hair, amino-acid content, 65  
   cystine content, 64  
   elementary composition, 64  
   melanin content, 76  
   relation to skin, 82-83, 279  
   test for, 484  
   Van Slyke determination, 43  
 Hair tankage, 307-308  
 Half-round mill, 279  
 Handling of glue, 506-517  
 Hausmann numbers, 37-38, 449  
 Hectograph plates, 548  
 Hemocyanin, 43, 421  
 Hemoglobin, 43, 221  
 Hide glue, bleaching, 290, 314, 315  
   boiling, 282-287, 314  
   chilling and spreading, 292-294  
   clarification and filtration, 287-290, 314  
   colored, 291



Hide glue, drying, 294-300  
 evaporation, 290-292, 315  
 liming, 279-281, 313  
 preparation of stock, 277-278  
 raw materials, 271-277  
 soaking and washing, 278-279, 313  
 special, 291  
 washing and deliming, 281-282, 314

Histidine, 22, 36, 39, 40, 42, 65

Historical considerations, 1-5

Hollander, 278

Hoof, 64, 82, 83, 279, 301

Hooke's law, 178

Horn, 64, 65, 82, 83, 301

Hornpiths, 275

Humagsolan, 67

Humins, 38, 39, 41, 74-76

Hydration, 127, 152, 157, 159, 183, 238

Hydrochloric acid, 616

Hydrogen electrode, 583-591  
 ion concentration, 450, 500, 576-606

## I

Ice cream, 477-478, 561-567

Ichthylepidin, 77-80, 88

Imitation rubber, 547

India ink, 554

Indicators, 599-606

Infant dietary, 558-561

Invalid dietary, 558-561

Invertin, 92

Ionization constants, 606-608

Ionization equilibria, 579-583

Ion series, 243-245

Isinglass, 349-356

composition, properties, uses, 354-356

constitution, 28

elementary composition, 50

forms, 349-353

gold number, 123

manufacture, 350-354

preparation, 4, 90

surface tension, 115

Van Slyke determination, 43, 46

Isinglass gelatin, 349

Isoelectric gelatin, 254, 255  
 point, 175, 246-247

Isoleucine, 22, 36

## J

Jelly strength, 367-380

effect of added substances on, 402

significance in evaluation, 500-501

tests for, 285, 370-380

variation with pH, 265

Joint work, 534-536

Junk bone, 273, 275

## K

Keratin, 20, 36, 63-67, 78-80, 83, 88

Kind-Landesmann machine, 293, 315

Kinematic viscosity, 384

Kip stock, 272, 274

Koilin, 65

## L

Lace leather, 273, 274

Laminaria, 165

Law of mass action, 220

Leach liquors, 473-440

Lead, 462-463

oxide, 444

Leather, 2, 51

Leather-metal adhesive, 537

Legumin, 36

Leucine, 21, 35, 36, 65

Liesegang rings, 93-95

Ligamentum nuchæ, 67, 68, 84, 85

Lime, 277

Liquid crystals, 138

Logarithms, 623-624

Log mill, 278

Loom pickers, 273

Losses due to overheating, 519-515

Lysine, 22, 36, 39, 40, 42, 65

## M

Magnesium oxide, 442-443

Mastic, 201

Matches, 545

- Meat, 470-477  
 extracts, 470-477
- Melanin, 39, 41, 74-76, 78-80
- Melting point, 399-411  
 definition, 118  
 determination, 207-208  
 effect of hydrolysis on, 401-404  
 evaluation by, 496  
 methods of measuring, 404-411  
 of gelatin, 54  
 scientific basis of test, 400-404
- Menhaden, 78, 88
- Metals in gelatin, 456-463
- Metric-American equivalents, 615
- Micelle theory, 264-268
- Milk, 477-478, 559
- Millon's reaction, 46
- Molecular weight, 107-114
- Molisch's reaction, 47
- Monoamino nitrogen, 38, 40
- Moulding material, 546
- Mucins, 69-73, 78-80, 280, 288
- Mucoids, 69-73, 85
- Mutarotation, 156-157, 209, 400-401, 413-415
- N
- Nails, 64
- Neurokeratin, 64
- Night-blue, 192
- Nitric acid, 616-617
- Nitrogen, determination, 431-433  
 distribution as amino-acids, 36  
 as Hausmann numbers, 38  
 as protein, proteose, peptone, and amino-acids, 25-29  
 by method of Van Slyke, 38-45  
 in gelatin, 433  
 in meat extracts, 476  
 total in proteins, 17
- Nitrous acid method for amino-acids, 30
- Nonamino nitrogen, 38, 40, 42
- Noodle glue, 298
- O
- Occlusion theory, 131, 157-159
- Optical rotation, 116-119, 413-415
- Organic analysis of gelatin, Fischer's esterification method, 35, 449-450  
 Hausmann numbers, 37-38, 449  
 protein, proteose, peptone, and amino acid, 25-28, 448-449  
 Van Slyke analysis, 38-46, 449
- Ornithine, 39
- Osmosis, 97-104
- Osmotic pressure, determination, 103-104  
 Donnan equilibrium on, 130-131  
 membranes for, 97  
 molecular weight by, 108-110  
 of gelatin salts, 99, 249, 256-257  
 swelling phenomena, 171-173
- Ossein, composition, 87  
 content in bone, 88  
 manufacture, 303-306, 317  
 mucoid from, 70  
 relation to cartilage, 86
- Ossealbuminoid, 86, 87
- Osseomucoid, 70, 87
- Ovomucoid, 92, 123
- Oxyproline, 23, 35, 36, 40
- P
- Packer bone, 273
- Paints, 544-545
- Panel work, 534-536
- Paper, 56, 485-486, 538-542  
 boxes, 536
- Parmelee catchall, 291, 292
- Pepsin, 16, 24, 51-52
- Peptids, 23, 24
- Peptone, 21, 23, 25-28, 127, 448-449
- Peter Cooper grades, 369
- Pharmaceutical preparations, 569-571
- Phenylalanine, 22, 35, 36, 65

- Phosphate by-product, 309-313, 317  
 Phosphoric acid, 434-440  
 Photography, 571-574  
 Photolithography, 571-574  
 Pickle baths, 554  
   bone, 273  
 Picric acid precipitation, 466-467,  
   477  
 Pills, 570  
 Plasticity, 207-212  
 Poise, 384  
 Potassium hydroxide, 619  
   oxide, 444-446  
 Potential difference, 129-131  
 Potentiometer, 588, 592  
 Preservatives, 277, 281, 291  
 Printing rollers, 547  
 Proline, 22, 36, 40, 65  
 Protective action, 123, 127-128,  
   550-554, 558-567  
 Protein error, 605  
 Proteins, amino-acid composition, 36  
   amphoteric character, 219, 236  
   classification, 18-19  
   cleavage products, 20-21  
   color reactions, 42-47  
   combining capacity, 229, 232  
   description, 15  
   determination, 25-28, 448-449  
   effect of inorganic ionogens, 236,  
     268  
   electrolysis, 227-229  
   electrophoresis, 227-229  
   elementary composition, 17  
   Hausmann numbers, 38  
   hydrolysis, 16, 24  
   ionization, 225-227  
   ion series, 243-245  
   isoelectric point, 246-247  
   precipitation and coagulation,  
     236-239  
   types, 16  
   Van Slyke determination, 38-45  
 Protein salts, acid and metal salts,  
   248-253  
   depressing action, 260-264  
   equilibrium, 245-253  
   formulas, 223-226, 232, 232-  
     235, 240-243  
 Protein salts, hydrolytic dissocia-  
   tion, 232-234  
   influence of valency, 253-260  
   mechanism of formation,  
     223-225  
   theories of ionization, 225-  
     227, 234-235, 239-243  
 Proteoelastose, 68 <sup>448-449</sup>  
 Proteose, 20, 23, 25-28, ~~248-249~~  
 Proximate analysis, 429-433  
 Psychrometric tables, 294, 295, 296  
 Pulp color, 539
- R
- Refined isinglass, 349  
 Refractive index, 119-121  
 Refrigeration, 315  
 Reynold's criterion, 383  
 Rose-Gotlieb method for fat,  
   329-330  
 Roller mill, 278  
 Rosin, 484  
 Rubber, 130, 538, 552-554
- S
- Saliva, 70, 72  
 Salivary calculi, 72  
 Salmine, 38  
 Salt effect, 605  
   precipitation, 25-28, 468-470,  
     475-477  
 Salts, 182-186  
 Sand paper, 545  
 Sclero-proteins, 19-20  
 Scyllium stellare, 65  
 Semplar, 135  
 Sepia, 76  
 Sericin, 36  
 Serine, 22, 35, 36, 65  
 Serum albumin, 36  
   globulin, 36  
 Setting point, 118, 403 ✓  
   rate, 416  
 Sheet glue, 298  
 Silica, 434  
 Silicic acid, 133  
 Size, 538-545

- Skin, 1-2, 79-84, 88-90, 279  
 Skivings, 272  
 Snail, 70, 71  
 Soap, 115, 138-141, 215-216  
 Sodium hydroxide, 619  
   oxide, 444-446  
 Solubility, 54-55  
   of bases, 42  
   product, 220  
 Solution, 164, 169-171, 186  
 Solvation, 173, 193-194  
   potential, 205  
 Solvents for degreasing, 301-302  
 Sørensen value, pH, 581  
   of isoelectric point, 175  
   of pure gelatin, 62  
   significance, 579-606  
 Sounds, 90  
 Specific gravity tables, 611-613,  
   616-620  
   rotation, 116, 117  
 Splits, 272, 274  
 Spray drying, 299-300, 316  
 Starch, 123, 129, 165  
 Statistical considerations, 5-12  
 Steamed bone, 273  
 Sterilization of hide stock, 277  
 Stokes' law, 201  
 Strip glue, 298  
 Structure, 124, 132-159  
 Submaxillary, 70, 71  
 Sulphate, 447  
 Sulphur, 201  
   dioxide, absorption of bones, 303  
   as bleaching agent, 4, 290  
   determination, 452-454  
   for leaching bones, 306, 317  
   for neutralizing lime, 282  
   in acid treatment, 276  
   reaction, 47  
 Sulphuric acid, 616-618  
 Surface tension, 114-116, 205  
 Suspensoid, 163, 201  
 Swelling, 164-186  
   capacity, 415-416  
   chemical phenomena in, 173-  
   182  
   effect of electrolytes on, 153,  
   182-186  
   Swelling, effect of gelatin salts, 249-  
   250, 257-258, 265  
   of hide stock, 282  
   osmotic phenomena in, 171-173  
   physical equilibria, 164-171  
   theories, 176-186  
 Syneresis, 172
- T
- Tannic acid, 51  
 Tannin precipitation, 464-466, 474-  
   475, 476  
 Tendomuroid, 70, 86  
 Tendon, 70, 85  
 Tensile strength, 403, 411-413  
 Testing of glue and gelatin, 367-424  
   adhesive strength, 411, 526-534  
   appearance, etc., 420-421  
   foam, 416-418  
   grease, 418-419  
   inspection test, 421-422  
   jelly strength, 369-380  
   melting point, 399-411, 496  
   optical rotation, 413-415  
   rate of setting, 416  
   reaction, 419-420, 500  
   swelling capacity, 415-416  
   tensile strength, 411-413  
   viscosity, 380-399  
 Textiles, 542-544  
 Theory of indicators, 599-606  
 Thermostat, 590  
 Thickeners, 478-479  
 Tin, 461-462  
 Tooth preservation, 72-73  
 Tortoise shell, 64  
 Total acidity, 450  
   alkalinity, 450  
 Trypsin, 16, 24, 51-52  
 Tryptophane, 23, 36, 39, 40, 65  
 Tumbler, 278  
 Twaddell degrees, 611-613  
 Tyndall effect, 54, 123-128  
 Tyrosine, 22, 35, 36, 65
- U
- Ultrafiltration, 575-576



Ultramicroscope, 126, 127  
 Ultramicroscopy, 123-128  
 Urea, 39

## V

Vacuum dryers, 299  
   evaporators, 290  
 Valine, 21, 36, 65  
 Van Slyke analysis, 38-46, 449  
 van't Hoff's law, 101, 105  
 Vapor pressure, 104-105  
 Vegetable glue, 362-363  
 Viscosimeter, Baumé and Vigneron,  
   390-391  
   Bingham, 389-391  
   capillary tube type, 384-392  
   Cope, 391-392  
   Couette, 395-396  
   Engler, 384-387  
   Kahrs, 387-388  
   MacMichael, 148, 189, 397-399,  
     496-499, 608-610  
   oscillating cylinder and disk  
     type, 394-395  
   Ostwald, 193, 389-391  
   Redwood, 384-387  
   Rideal-Slotte, 390-391  
   rising bubble and falling sphere  
     types, 392-394  
   Saybolt, 384-387  
   Stormer, 396-397  
   torsional type, 394-399  
 Viscosity, 186-212, 380-399  
   change on standing, 149-151  
   conditions affecting, 187-200  
   effect of electrolytes on, 153  
   evaluation by, 496-497

Viscosity, instruments for measuring,  
   384-399  
   MacMichael conversion, 608,  
     610  
   of castor oil, 609  
   of gelatin solutions, 138, 259,  
     262-265  
   plasticity relationship, 207-212  
   relation to melting point, 402  
   tests for, 285  
   theories of, 200-207, 381-384  
 Volatile acids, 451  
 Volume comparison table, 614

## W

Water, 275-276, 314  
 Water-resistant glues, 318-348  
   animal glue, 537-538  
   blood albumin glue, 344-348  
   casein glue, 319-344  
 Whalebone, 64  
 White glue, 291  
 Wool, 64-65, 484

## X

Xanthoproteic reaction, 47

## Y

Yield value, 210

## Z

Zein, 36, 221  
 Zinc, 460-461  
   oxide, 443



## AUTHOR INDEX

### A

Abderhalden, 23, 24, 36, 64, 65, 78  
 Abel, 75, 76  
 Abrahms, 341  
 Abt, 313  
 Acree, 585  
 Alexander, 20, 49, 193, 314, 373-374,  
     388, 488-489, 491, 558, 559  
 Alexandrow, 106  
 Allen, 57, 472  
 Almy, 365  
 Anders, 36  
 Anderson, 315  
 Arkwright, 145  
 Arney, 4  
 Arnheim, 59  
 Arnold, 392  
 Arrhenius, 178  
 Arrowood, 315

### B

Bachmann, 127, 141, 142  
 Bacon, 375  
 Badische, A., 314  
 Badische, S., 314  
 Bahntje, 551  
 Baker, 322  
 Baldwin, 178  
 Bancelin, 201  
 Bancroft, 115, 116, 121, 127, 141-  
     142, 163, 214-215, 218, 314,  
     483, 552  
 Barcroft, 98  
 Barraclough, 484  
 Bauer, 64  
 Baumé, 391  
 Baxter, 315  
 Bayliss, 102, 109  
 Beans, 580  
 Beatty, 36  
 Bechhold, 54, 95, 134, 206

Bechmann, 473  
 Behrend, 343  
 Bellamy, 341  
 Benedict, 41, 605  
 Benzinger, 182  
 Bergel, 341  
 Bernstein, 342  
 Berrar, 113, 466  
 Bert, 315  
 Berthelot, 58  
 Betts, 551, 552  
 Bevan, 56, 485  
 von Biehler, 36  
 Biltz, 102, 114, 192, 197  
 Bingham, 209, 383, 385, 391  
 Birchard, 221  
 Blasel, 62, 223, 226  
 Blish, 39, 43, 75, 449  
 Bogue, 25, 27, 43-46, 57, 120, 127,  
     145-159, 178, 184, 187-189,  
     192, 194, 197, 200, 204-206, 210,  
     217, 239, 264, 401, 410, 423,  
     428, 429, 432, 433, 435, 449,  
     469, 493, 495, 511, 523, 577  
 Booth, 314  
 Bordet, 145  
 Born, 315  
 Botazzi, 204  
 Bourcart, 569  
 Bourgeois, 74, 113, 433  
 Brabrook, 343, 344  
 Bracket, 313  
 Braconnot, 59  
 Bradford, 94, 143  
 Bredig, 220  
 Bremer, 341  
 Briggs, 56, 214, 485  
 Brillouin, 381  
 Brito, 228  
 Brooke, 57  
 Brooks, 342  
 Broquette, 340  
 Browne, 328, 338, 346

Buchner, 143, 167  
 Buchtala, 64  
 Buerger, 85, 86  
 Bugarsky, 226  
 Bugge, 114  
 Buglia, 192  
 Bullowa, 558  
 Bunting, 72  
 Bunzel, 316  
 Burneister, 328  
 Burnett, 107  
 Burr, 328  
 Burton, 126, 176  
 Bütschli, 132  
 Butterman, 320, 325, 326, 335, 343

## C

Cambon, 317  
 Cammen, 315  
 Campbell, 316  
 Carles, 464  
 Carpenter, J., 396  
 Carpenter, W., 341  
 Carrier, 316  
 Carthans, 315  
 Cavalier, 315  
 Cerri, 491  
 Chercheffski, 207, 404  
 Chick, 204, 332  
 Child, 217  
 Childs, 340  
 Ching, 313  
 Chittenden, 50, 64, 68, 433  
 Clapp, 36  
 Clark, A. W., 407  
 Clark, E. D., 365  
 Clark, F. C., 485  
 Clark, W. M., 248, 320, 322, 323,  
 327, 328, 500, 583, 584, 587,  
 589, 590, 599-605  
 Clayton, 491  
 Clowes, 215  
 Coffman, 152, 182  
 Cohn, 77  
 Congdon, 478-479  
 Cope, 392  
 Cormack, 286, 314  
 Couette, 382, 395

Coulomb, 381  
 Cross, 56, 485  
 Cutter, 70

## D

Dahlberg, 321, 322, 327  
 Dakin, 34-37, 59, 112, 114  
 Daubine, 316  
 David, 569  
 Davidson, 314  
 Davis, 75, 76, 149  
 Dawidowski, 48, 74, 83, 435, 548  
 DeBary, 116  
 DeBruyn, 123  
 Deeley, 383  
 DelQuercio, 569  
 Dennis, 41  
 DesCondres, 215  
 Devos, 315  
 Dietrich, 365  
 Donnan, 128, 168, 184  
 Doolittle, 394-395  
 Dorner, 317  
 Dörpinghaus, 36  
 Dreaper, 66  
 DuBois, 407  
 Duclaux, 101, 110  
 Duerling, 316  
 Dumanski, 206  
 Dunham, A., 342, 343  
 Dunham, H., 317, 342, 344  
 Dutton, 314

## E

Ebstein, 65  
 Eckweiler, 452  
 Eder, 572  
 Ehrenberg, 177  
 Einstein, 93, 200  
 Ekman, 366  
 Ellenberger, 313  
 Elliott, 55, 122, 127, 590-591, 605  
 Ellis, 587  
 Emery, 475  
 Emmett, 50  
 Erlwein, 316



d'Errico, 204

## F

Fahrion, 455, 467

Fales, 178

Falk, 452

Fargas-Oliva, 342

Faust, 50, 392

Fels, 372, 387, 491

Ferguson, 620

Fernbach, 318, 370, 388, 419, 487,  
488

Ferney, 343

Fick, 92

Field, 62, 102

Finsterwalder, 316

Fischel, 314

Fischer, E., 317

Fischer, Emil., 18, 35, 36

Fischer, M., 92, 98, 120, 144, 152,  
155, 156, 159, 161, 162, 163, 172,  
182-184, 191, 194, 208, 214,  
216-217, 250, 568, 577

Fischer, R., 393

Flade, 141

Fletcher, 343, 344

Flowers, 381, 383, 393-394

Fohn, 72

Forrester, 316

Framm, 116

Fransden, 562

Frankenheim, 132

Fremy, 50

Freundlich, 95, 138-139, 163

Friedenthal, 106

Frost, 512

Fuchs, 67

Funk, 36

## G

Gamble, 366

Gantlier, 317

Gantter, 464

Garner, 128, 184

Garrett, 133-134, 135, 146, 196, 394

Garry, 418

Gayley, 316

Gibbs, 115

Gibson, 393

Gies, 50, 67, 70, 85, 86

Gill, 411, 523, 526, 527-529, 534

Girsenwald, 317

Gokun, 197

Goldsmith, 341

Gomberg, 229

Gortner, 39, 75

Govers, 342

Graham, 17, 92, 95, 160, 172, 206

Grant, 569

Grasser, 313

Green, E., 77, 78, 88, 366

Green, H., 209

Greifenhagen, 468

Grete, 576

Grillo, 317

Grindley, 315

Grosvenor, 316

Groth, 366

Gruendler, 341

Grune, 340

Gudeman, 453

Guldberg, 220

Guthrie, 105

## H

Hackford, 417, 468

Hall, 341, 342

Halla, 433, 465

Hammerstein, 70, 72

Handovsky, 241

Hardy, 133, 142, 227, 236

Harmed, 178

Harris, 37, 128, 184

Harrison, 201

Hart, 68, 316, 456

Hatschek, 94, 95, 122, 164, 165,  
200-206, 395, 575, 577

Hauck, 314

Hauseman, 534

Hausner, 313

Hawk, 70, 86

Hayes, 383, 398, 435

Haynes, 341

Hedenberg, 568

Heicke, 273-275

- Heim, 343  
 Heinemann, 532  
 Henley, 475  
 Henri, 163  
 Henzold, 478  
 Herold, 297, 404, 406  
 Herschel, 383, 398  
 Herschfeld, 223, 229, 230  
 Herter, 560  
 Herz, 484  
 Herzberg, 484  
 Herzog, 92  
 Hewitt, 341  
 Heyl, 36  
 Higgins, 397  
 Hildebrand, 314  
 Hill, 98  
 Hirsch, 340  
 Hoagland, 592-598  
 Hoffman, 15  
 Hofman, 215  
 Hofmann, 65  
 Hofmeister, 49, 50, 60, 100, 105, 166,  
     199, 243-245  
 Hohenstein, 341  
 Holborn, 227  
 Holmes, 95, 194, 217  
 Hooker, 182, 183, 216, 568  
 Hopfner, 328  
 Hopke, 456  
 Hopkins, 57  
 Hopp, 412  
 Hoppe-Seyler, 76  
 Horbaczewski, 68  
 Horne, 453  
 Howell, 229  
 Hüfner, 206  
 Hulbert, 376  
 Hurwitz, 606  
 Husbrand, 315
- I
- Isaacs, 341, 342, 343, 344  
 Ives, 422
- J
- Jacobi, 559  
 Jacobs, 393  
 Jean, 464  
 Jenkins, 317  
 Jones, H., 147, 155, 173, 237  
 Jones, P., 568  
 Jovignot, 343, 344  
 Just, 341, 342
- K
- Kahlenberg, 96  
 Kahrs, 387-388, 489-490, 519, 527-  
     528  
 Kauffman, 557  
 Keane, 533  
 Kelvin, 487  
 von Kerkhoff, 64  
 Kern, 551  
 Kerr, 315  
 Kimberlin, 342  
 Kind, 315  
 King, 125, 127  
 Kirchman, 556  
 Kissling, 207, 372, 405  
 Kister, 316  
 Klug, 60  
 Knudsen, 366  
 Kochetkov, 317  
 Kohlrausch, 159, 227  
 König, 468  
 Konovalov, 124  
 Koplik, 560  
 Körner, 64, 169  
 Kossel, 17, 234  
 Krafft, 106, 107  
 Krawkow, 76  
 Krombholz, 560  
 Krüger, 116  
 Krukenberg, 74  
 Krummacher, 556  
 Kühne, 64  
 Kutscher, 472  
 Küttner, 207, 406
- L
- Ladenberg, 392  
 Laing, 137, 148  
 Lambert, 317

- Landwehr, 71, 74  
 LaWall, 454  
 Leavenworth, 223  
 LeChattelier, 5?  
 LeConnt, 65  
 Leffman, 454  
 Lehmann, 286, 314  
 Levene, 36, 59, 69  
 Levi, 483  
 Levites, 197  
 Lewis, 171, 200, 201, 383, 398  
 Lewis, W., 316  
 Liebermann, 226  
 Liesegang, 93  
 Lillie, 97, 98, 100, 101, 102, 260  
 Lindauer, 343  
 Lindemuth, 366  
 Linder, 512  
 Lipowitz, 371  
 Lloyd, 129, 143, 144-145, 167-168  
     231-232  
 Lodeman, 569  
 Loeb, 55, 62, 91, 97, 98, 100, 102,  
     110, 114, 128, 129-132, 137, 147,  
     149, 157-159, 174, 175, 177, 182  
     184-186, 187, 195, 199, 219, 241,  
     245, 247-253, 254, 255, 256, 257,  
     258, 259, 260, 268, 500, 573, 577  
 Loomis, 585  
 Low, A., 317  
 Low, W., 377  
 Lowenstein, 315  
 Lubs, 323, 599-605  
 Lucke, 315  
 Lüdeking, 53, 104, 107, 164  
 Lumière, 57, 572  
 Lunge, 533, 619  
 Luppö-Cramer, 577
- M
- McBain, 137-141, 147, 148, 264-268  
 Macintire, 315  
 McLaurin, 341  
 McMeekan, 341  
 MacMichael, 397  
 Majert, 341  
 Markham, 562  
 Marlow, 316  
 Marr, 316
- Martici, 191  
 Martin, 125, 204, 332  
 Mathews, 17, 81, 87  
 Matula, 62, 223, 226  
 Mauerhofer, 286, 314  
 Mavrojannis, 468  
 Maxwell, 403  
 Mehler, 114  
 Meinford, 315  
 Menz, 122, 127  
 Merkle, 431  
 Merrell, 315  
 Merrill, I., 316  
 Merrill, O., 316  
 Meyer, 606  
 Michaelis, 175, 195, 247, 314, 580  
     582  
 Millikan, 105  
 Miyake, 170  
 Mohler, 313  
 Moore, H., 315  
 Moore, R., 102, 313, 560  
 Morawska, 316  
 Mörner, 50, 57, 64, 70, 73, 74, 77  
     86, 88, 366  
 Morochowetz, 73  
 Mülder, 64, 433  
 Müller, A., 70, 463, 465  
 Müller, E., 551  
 Mürlin, 556-557  
 Mutscheller, 314
- N
- von Nageli, 132  
 Neil, 314  
 Nelson, 178  
 Nencki, 76  
 Nernst, 97, 129, 166, 171, 583  
 Neuberg, 76  
 Neumann, 163  
 Newman, 213  
 Newton, 425  
 Northrup, 25  
 Nowak, 342  
 Noyes, A., 163, 169  
 Noyes, H., 452
- O
- Oakes, 149, 379, 580

- Obernethy, 302  
 Odén, 201  
 Oesterle, 316  
 Okuda, 322, 366  
 Onfrey, 480  
 Oryng, 226  
 Osborne, 35, 36, 37, 223  
 Ostenberg, 606  
 Ostwald, Walther, 213  
 Ostwald, Wilhelm, 92, 94, 390  
 Ostwald, Wolfgang, 92, 93, 98, 108,  
 109, 110, 114, 135, 159, 160, 161,  
 162, 163, 172, 174, 187, 191, 194,  
 577  
 Ota, 173, 237  
 Oyamo, 366
- P
- Paal, 110, 111, 113, 433  
 Padé, 453  
 Paessler, 84  
 Parker, 366  
 Parr, 383  
 Patrick, 477  
 Pauli, 54, 100, 157, 159, 166, 174,  
 194, 195, 199, 223, 226, 228, 229,  
 230, 241, 244, 260, 577  
 Peck, 340  
 Perrin, 105, 163  
 Phelps, 314  
 Pickering, 214, 215, 315  
 Pickles, 313  
 Pitman, 397  
 Plateau, 214  
 Plimmer, 21, 51  
 Poetschke, 454  
 Poiseuille, 381  
 Poma, 178  
 von Portheim, 340  
 Posnjak, 165  
 Post, 533  
 Posternak, 244  
 Potter, 354  
 Pregl, 64, 65  
 Procter, 52, 110, 111, 114, 128, 129,  
 136, 147, 172, 176-182, 185, 258,  
 314  
 Prollius, 354, 366
- Q
- Quinke, 53, 114, 133, 134, 141, 164,  
 173, 214
- R
- Ramsden, 115  
 Rankin, 391  
 Rauppach, 341  
 Rayleigh, 125, 126  
 Reid, 98, 101  
 Reimer, 84  
 Reinke, 165  
 Reiss, 119  
 Renken, 342  
 Reuter, 327, 343  
 Reynolds, 382  
 Ricevuto, 55  
 Richards, 50, 67  
 Richardson, 471  
 Richmond, 331  
 Rideal, 56, 60-61, 391, 472  
 Rigg, 396  
 Roaf, 98, 102  
 Robertson, 101, 107, 108, 116, 119,  
 121, 123, 136-137, 146, 170, 173,  
 177, 206-207, 213, 223, 226, 229,  
 230, 233, 239  
 Roehm, 313  
 Rogers, 396  
 Rollet, 84  
 Roma, 244  
 Ross, C., 340  
 Ross, J., 340  
 Rothberg, 575  
 Roy, 316  
 Royal, 342  
 Rozens, 316  
 Rudeloff, 529  
 Ruggles, 316
- S
- Sabenejew, 106  
 Sabin, 396  
 Sadtler, 315  
 Sakidoff, 50, 433  
 Salm, 599  
 Salmon, 137, 147, 265  
 Samec, 54, 228



- Sammett, 407  
 Samuley, 75  
 Sanford, 341, 343  
 Scarpa, 314  
 Schereschewsky, 560  
 Scherrer, 144  
 Schmidt, 214, 484, 592-598  
 Schöler, 481  
 Scholl, 468  
 Schorer, 64  
 von Schroeder, 55, 84, 135, 143, 167,  
     189, 196, 197, 317  
 Schryver, 25, 27, 122, 225  
 Schützenberger, 74, 113, 433  
 Schwarz, 67, 68  
 Schwickerath, 366  
 Scott, 373, 378-379  
 Scott, W., 443, 444, 462  
 Searle, 57, 472  
 Seeman, 59  
 Seidell, 309, 310  
 Seidenberg, 477  
 Setterberg, 411, 533  
 Seyewetz, 57, 572  
 Shattermann, 416  
 Shaw, 328  
 Sheppard, 122, 149, 152, 208, 378-  
     379, 392, 403, 407-410, 422  
 Sherman, 557  
 Sherrick, 526  
 Shuey, 271-317, 435, 437-440, 448  
 Siebel, 315  
 Sieber, 76  
 Siedentopf, 124  
 Sindall, 375  
 Skraup, 36  
 Slough, 342  
 Smith, 66, 87  
 Smith, C. R., 50, 102, 110, 114, 117,  
     156, 173, 207, 212, 377, 392, 400,  
     407, 413-415, 433, 496  
 Smith, E., 375-376  
 Smith, G., 237  
 Smits, 104  
 von Smoluchowski, 93, 109  
 Snell, 314  
 Solley, 413  
 Sørensen, 27, 30, 245, 581, 586, 587,  
     599  
 Stacy, 316  
 Starkweather, 315  
 Statham, 343  
 Steinitzer, 548  
 Stefan, 92  
 Steffans, 340  
 Stelling, 372, 463  
 Stewart, 56, 60-61, 472  
 Stieglitz, 97, 220, 608  
 Stirling, 228  
 Stohmann, 58  
 Stokes, 382, 392  
 Stokes, A., 477  
 Strauss, 228  
 Street, 317  
 Sturtz, 106  
 Stutzer, 471  
 Supp, 343  
 Sutherland, 134, 139  
 Svedberg, 93  
 Sweet, 208, 378-379, 403, 407-410
- T
- Taggart, 88  
 Tague, 452  
 Talman, 342  
 Tammann, 105  
 Tanner, 575  
 Taylor, 265, 391  
 Tellotson, 35  
 Thiel, 599  
 Thiele, 7, 12, 286, 314, 491  
 Thomas, 112, 125, 178, 213, 218  
 Thompson, 143  
 Thubé, 342  
 Tidley, 316  
 Tiebackx, 314  
 Tiemann, 316  
 Tilanus, 64  
 Tower, 77, 78, 88, 366  
 Tressler, 349, 356-366, 435  
 Trillat, 480  
 Trotman, 417, 468  
 Trunkel, 117, 466  
 Tyndall, 298, 316
- U
- Uhler, 237

Ulrich, 207, 406  
Upton, 286, 314

## V

Valenta, 372-373  
Vamvakas, 480  
Van Bemmelen, 132, 191  
Vandergrift, 85  
Van Laar, 64, 97  
Van Name, 50, 433  
Van Slyke, 24, 27, 30-34, 38-45, 59,  
221, 322, 621  
von Vegesack, 102, 192  
Venuleth, 313  
Vernon, 222  
Vignerón, 391  
Viktorin, 366  
Vining, 340  
Vogt, 73  
Voightländer, 92, 206  
Voitinovici, 65, 78  
Vorlander, 138

## W

Waage, 220  
Wagner, 241, 481  
Walker, 171, 390  
Walpole, 119-120, 586  
Washburn, 562, 564  
Weelands, 343  
Weidenbusch, 533  
Weimar, 322  
von Weimarn, 161  
Wells, 65

Welmers, 532  
White, 350, 355, 366  
Whitney, 169  
Wiedemann, 53, 164  
Wiegand, 553-554  
Wiglow, 107  
Williams, K., 366  
Williams, O., 562, 563, 564  
Wilson, J. A., 81, 88, 111, 114, 128,  
143, 176, 178, 179-182, 185, 258,  
324  
Wilson, W. H., 179-182, 314  
Winkelblech, 116, 207, 217-218, 406,  
482-483  
Winton, 453  
Wittkowsky, 341  
Wolf, 76, 143, 167  
Wright, 315

## Y

Youle, 391  
Young, 76

## Z

Zaensdorf, 537  
Zdenek, 76  
Zeynek, 76  
Ziegler, 54, 134, 206  
Zlobicki, 115  
Zoller, 322, 324, 328, 332, 563  
Zomer, 4  
Zsigmondy, 54, 92, 121, 124, 127,  
141, 161  
Zuntz, 66, 81









