

Book I

**MODERN GLUES AND
GLUE TESTING**

(Other than Waterproof Glues)

BY

CLYDE H. TEESDALE, A. B.Formerly in charge, Section of Wood Preservation, Forest Products
Laboratory, Madison, Wisconsin

With an Appendix

Methods of Testing Animal Glues at the Forest Products Laboratory, Madison, Wis., in which is set forth the standards of the Bureau of Aircraft Production, U. S. Army

Published By
THE PERIODICAL PUBLISHING CO.
GRAND RAPIDS, MICHIGAN



10



Franklin
Walsh
2-9-35
2-11-35

Franklin
George
5-13-34

Copyrighted by
The Periodical Publishing Co.
Grand Rapids, Michigan
1922

44

Print
Walt
2-9-35
2-9-35

Transfer
Jenae
5-13-34

Copyrighted by
The Periodical Publishing Co.
Grand Rapids, Michigan
1922

PREFACE

When the United States entered the great war and it became necessary to build airplanes by thousands, very definite specifications and satisfactory methods of testing glues were sorely needed. The problem of developing specifications and methods of test was turned over to the Forest Products Laboratory and was worked out under my direction.

This book is based largely on the results that were obtained, and which were applied in practically all purchases of glue during the war by both the Army and Navy Departments. General information on the manufacture and use of glues is given, and a description of the methods of testing that are described in the literature on the subject.

Acknowledgement is made to Mr. A. T. Deinzer of Monroe, Mich., who contributed valuable information used in compiling this book; also to Mr. Geo. M. Hunt of the Forest Products Laboratory for valuable suggestions and criticisms and for contributions to parts of the text, and to Mr. L. J. Markwardt, Mr. A. C. Knauss, and Mr. Wilbur Lloyd Jones, of the Forest Products Laboratory, for contributions to the text.

THE AUTHOR.

BOOK I

TABLE OF CONTENTS

CHAPTER I—*General Discussion*—

(Earliest Record of Glues)—Distinction between Glues and Gelatine—General Process of Animal Glue Manufacture—Resulting Variation in Properties—Determination—The Peter Cooper Grades..... 11

CHAPTER II—*Miscellaneous Glues*—

Fish Glues—Liquid Glues—Vegetable Glues—Casein Glues—Blood Albumin Glue—Silicate of Soda..... 15

CHAPTER III—*Uses of Glue*—

Paper—Paper Boxes—Books—Straw Hats—Wall Paper—Matches—Leather Goods and Belting—Textiles—Writing Tablets—Woodworking 19

CHAPTER IV—*Glue Testing (Preliminary)*—

Preliminary Examination—Absorption of Moisture from the Air—Appearance—Selecting of Samples—Surface and Other Bubbles—Odor—Gloss—Color—Fracture—Foam—"Keeping" Qualities 23

CHAPTER V—*Glue Testing*—

Evidence of a Single Test not Conclusive—Moisture—Ash—Acidity—Grease—Water—Absorption—Melting Point 27

CHAPTER VI—*Viscosity*—

Types of Viscosimeters—Engler Viscosimeter the U. S. Government Standard—Viscosity Determination at U. S. Forest Products Laboratory—Value of Viscosity Test 31

CHAPTER VII—*Jelly Strength*—

The Finger Test—Lipowitz Test—Edmund S. Smith Testing Apparatus—Jerome Alexander—Value of Jelly Strength Test..... 37

CHAPTER VIII—<i>Strength of the Glued Joint—</i>	
Joint Tests Indicate Quality of Workmanship Rather than Glue Strength—Selection of Woods for Glue Tests—Variation in Application of Glue and Manufacture of Joint—Application of the Load—The Spandau Test—British Royal Aircraft Test—Aeronautical Inspection—Directorate (England) Method—Shear Test and Tension Test—A Widely Used Method Discarded at Madison, Wis.—The Forest Products Laboratory Shear Test—A Modification of Madison Standard Test—Miscellaneous Tests—Plaster Rod Test—Setterburg Test—Gill Test	41
CHAPTER IX—<i>Plywood Strength Test—</i>	
Equipment and Method Adopted as Standard at the Forest Products Laboratory, Madison, Wis.....	57
CHAPTER X—<i>Specifications—</i>	
Bureau of Aircraft Production, U. S. Army—Specification for Handling and Testing Hide Glue—U. S. Government Standard Specification for Hide Glue Certified in Airplane Construction.....	63
CHAPTER XI—<i>Results of Tests on Miscellaneous Glues.</i>	
	71
CHAPTER XII—<i>Grading the Glue Sample—</i>	
Jerome Alexander and Peter Cooper Grades Compared—Table of Viscosities and Jelly Strengths for Alexander Standard Grades	77
CHAPTER XIII—<i>Some Interesting Strength Data on Glues—</i>	
Woods that give Strong Joints—Scratched Joints versus Smooth Joints—Laminated Construction—Resistance of Animal Glues to Moist Air.....	81
CHAPTER XIV—<i>Use and Application of the Glue Hydrometer</i>	
	85
APPENDIX.	
Methods of Testing Animal Glue at the Forest Products Laboratory, Madison, Wis., 1919 Standards of the Bureau of Aircraft Production, U. S. Army.....	87

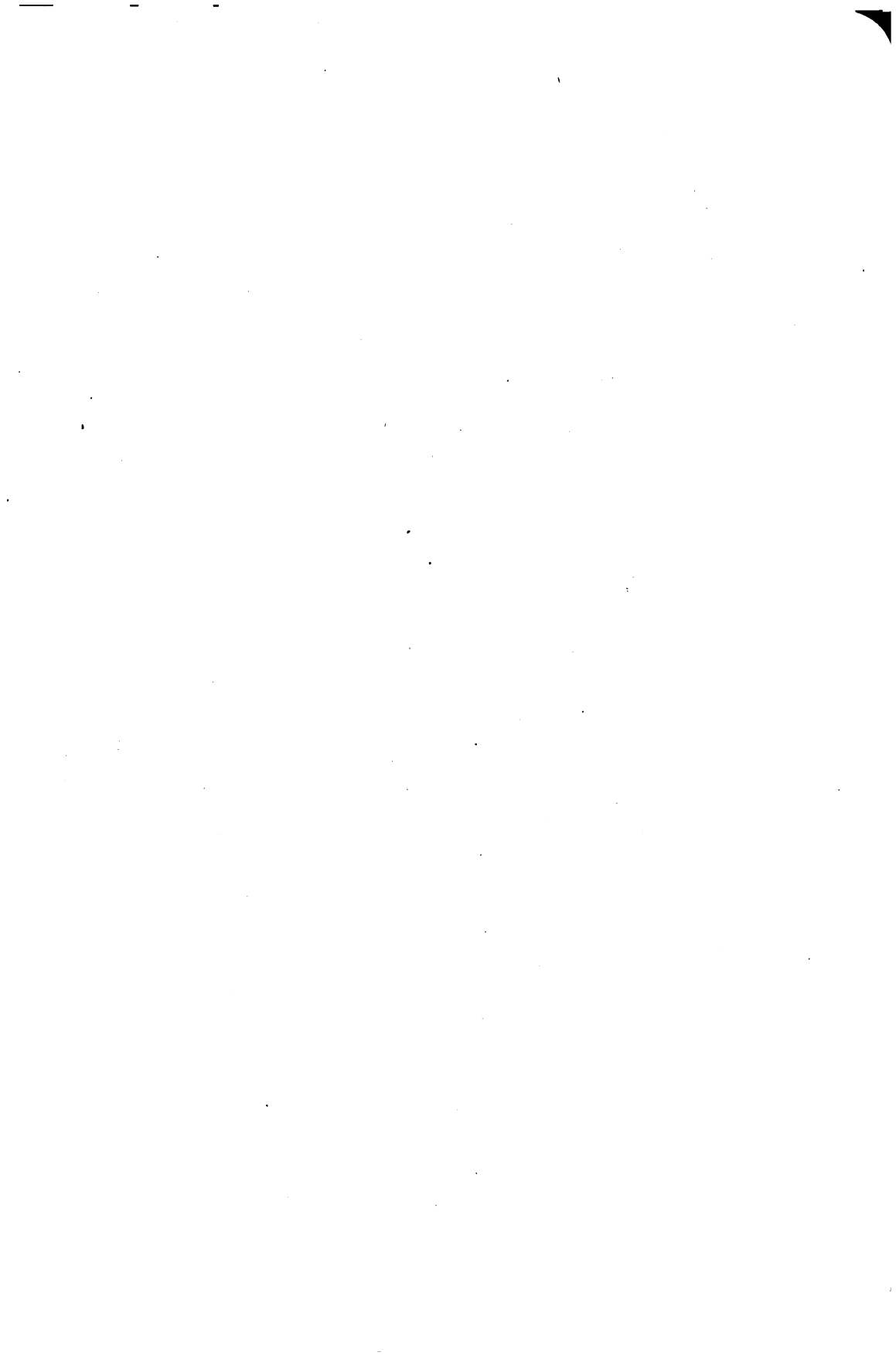



CHAPTER I.

GENERAL DISCUSSION

IT is said that glue has been known and used for thirty-three hundred years. Furniture found in tombs of the ancient Egyptians of the period of the Exodus was dovetailed, and joined with glue and nails. Romans, of the time of Cicero, were familiar with glue, and it was in extensive use in England during the reign of Queen Elizabeth.

EARLIEST
RECORD OF
GLUES.

The term glue is used in its broadest sense to denote an adhesive. Used in this sense it includes a great variety of substances. The oldest and best known of these is animal glue. Animal glue comes in an almost infinite variety, due to the differences in methods of manufacture and the source and quality of the materials used. Glues or adhesives are also produced from starches, casein, blood albumin and sodium silicate.

In general, animal glue is a substance akin to gelatine, though not identical with it, and is produced from the bones, sinews, hides, etc., of animals. It is difficult to define the difference between glue and gelatine because these substances may be very similar in their composition, appearance and properties. Gelatine, however, is usually used for purposes in which absence of taste, odor and color, together with a firmness of jelly are desired. It is often used in foods. Consequently it is prepared from selected materials free from decomposition. Glue, on the other hand, is usually used for its adhesiveness, and lower grade materials and less care may be employed in its production.

DISTINCTION
BETWEEN
GLUES AND
GELATINE.

It is rather important for a glue user to have a clear idea of the difference between glue and gelatine and of the method of manufacture of glue. A true conception of this may cause him to change his methods of glue handling. The frequently heard statement that gelatine is a pure form of glue is not strictly correct. Neither glue nor gelatine occurs as such in

nature. They are formed by heating certain animal tissues in the presence of water. The action is chemical, not simply one of solution. A portion of the water molecule, according to recent ideas, combines chemically with the animal matter, the technical term describing the action being "hydrolysis." This action proceeds rapidly at a high temperature, and slows down as the temperature is lowered. Hence both time and temperature are important factors in glue making. As the action proceeds, a series of products is formed, each one differing slightly from the one from which it was produced. While neither glues nor gelatines are produced in this way commercially, we may consider, for our purpose, that the first one formed is gelatine. Continued action produces first very strong viscous glue, then weaker and weaker glues, until finally, if the action is continued long enough, a product is obtained that will not form a jelly when cold, and which has no adhesive properties. It makes no difference whether the heating occurs in the glue maker's boiler or in the wood user's shop room. Whenever the glue is heated in the presence of water, chemical action occurs which steadily reduces the quality of the product.*

GENERAL
PROCESS OF
ANIMAL GLUE
MANUFACTURE.

The process of making animal glue is, briefly, as follows: The stock is washed and treated to remove dirt and grease, then boiled to convert the glue-forming substances into a glue solution, which is concentrated by evaporation until it will form a jelly on cooling. The jelly is then dried and the resulting product is the glue.

VARIATIONS IN
METHODS OF
MANUFACTURE.

There are many details and variations in the steps above outlined which depend upon the kind of stock used and the plant in which the glue is made, all of which have more or less effect upon the character of the resultant glue. For instance, bones are sometimes boiled without first removing either dirt or grease. This naturally fails to produce a high-quality glue. It is common practice to treat bones with acid to remove the calcium salts before cooking, but this is not always done. In cooking, the temperature and time have to be

*See Rideal (Glue and Glue Testing), page 10.

carefully watched, as over-cooking may materially reduce the strength of the glue. The stock is usually boiled several times, using fresh water each time. The first boiling or first run gives the best glue, the strength of the glue obtained from the succeeding boilings being less each time. Sometimes two or more boilings from the same kettle, or boilings from different kettles, are mixed together or "blended" before the liquor is concentrated.

The solution of glue from the boiling kettles is too weak to form a jelly which can be handled, so it must be concentrated. This is done by boiling off the water in vacuum pans until the percentage of glue in the solution is high enough to make a firm jelly on cooling. If the temperature gets too high during the concentrating process the quality of the glue may be lowered.

When sufficiently concentrated the glue solution is cooled by refrigeration, either after being run into pans or as it runs upon a traveling belt. As it cools it forms a jelly firm enough to handle. The jelly in the pans is removed, sliced with wires or a knife, and placed upon screens to dry. If a belt is used the jelly is formed in a continuous sheet, which is cut into sections and placed on screens as it travels along. The screens are then placed in a drying chamber and left until the glue is dry. The glue may be easily injured during the drying process if the temperature conditions are not properly controlled. The form of the glue when dry depends upon the shape in which it was placed upon the screens. If carefully sliced to the proper thickness regular shaped cakes will be formed. The sheet glue from the belt breaks into thin irregular shaped pieces as it comes from the drying nets. This is commonly run through a machine to break it into smaller pieces, in which shape it is shipped as flake glue. Other miscellaneous forms of glue are also made, and any of them may be subsequently ground and sold as ground glue.

METHODS OF
COOLING.

MISCELLANEOUS
FORMS OF
GLUE.

Sometimes mineral matter such as barium sulphate, white lead, chalk, or whiting is added to the glue after it has been concentrated, but before it is cooled.

This gives it a light color and makes it opaque, which is a feature desired by some consumers.

From the above very brief description of various steps in the manufacturing process it can readily be seen that the variety in character, color, form, strength, etc., of glues can be almost without limit. A system of classification, based chiefly on the jelly strength, was devised a long time ago by Peter Cooper, by which it is possible to group the great variety of glues into a relatively few classes or grades. The grades established by Cooper, beginning with the strongest, were designated, respectively, A Extra, 1 Extra, 1, IX, $1\frac{1}{4}$, $1\frac{3}{8}$, $1\frac{1}{2}$, $1\frac{5}{8}$, $1\frac{3}{4}$, $1\frac{7}{8}$, 2. There are now glues stronger than A Extra, and glues weaker than 2, for which there is no standard Peter Cooper grade. This system of grading, however, appears to be but little used today by manufacturers, except sometimes for comparative purposes. Each manufacturer has his own system of grading which he keeps more or less secret, and to the general buying public the grades mean little or nothing. It is sometimes claimed also that the Peter Cooper grades of today are not the same as those established long ago.

PETER COOPER
GRADES.

CHAPTER II.

MISCELLANEOUS GLUES

FISH glue is made from the skins, bones, bladders, etc., of fish. The finest grades are made from the swimming bladders, and come on the market in the product known as isinglass. It is said that fish glues can be made that are practically equal in adhesiveness to hide or bone glues.

FISH
GLUES.

Liquid glues are marketed in liquid form ready for use. Most glues are so prepared that they can be used cold. They are quite popular and have a large sale. Usually they are higher in price than ordinary animal glues. They may be prepared by special treatment of hide or bone glue, but very often they are made from fish glues.

LIQUID
GLUES.

In recent years vegetable glues have been used in increasing quantities, especially for gluing veneers. At the start of the war the price of animal glue soared, and forced a very wide use of vegetable glues, especially in the veneer trade, where the use of animal glues was practically eliminated. The commercial importance of vegetable glue is now obvious to practically every large user of glue.

STARCH
GLUES.

Most vegetable glues are made from starch and alkali. Some consumers seem, however, to be successfully gluing with starch boiled in water, without the addition of alkali. The most commonly used vegetable glues are produced from cassava flour and caustic soda (sodium hydroxide). During the war the shortage of shipping facilities prevented the importation of cassava flour, and much potato starch was used, usually where possible in mixtures of as much of the cassava flour as possible. Corn starch has been used. Other materials than caustic soda, such as tri-sodium phosphate, sodium carbonate, etc., have been used. Sometimes the starch is treated with sulphuric acid (hydrolized or processed) before mixing with the alkali. The best qualities of vegetable glues, when properly made, show strength properties which com-

POTATO STARCH
GLUE

pare favorably with the medium to good grades of animal glues. They also have certain advantages of use, especially that of applying cold, that are well known to most of our readers. Vegetable glues are often criticised because of their rather common property of staining wood. Recent work indicates that this difficulty is being overcome.

The Perkins Glue Company, well known manufacturers of vegetable glue, made the following statement:

PERKINS
GLUE.

"Vegetable glue is manufactured by taking a carbohydrate such as cassava flour, the water absorptive property of which has been decreased or is already sufficiently low, but not too low, and mixing therewith the necessary small amount of water and dissolving the starch in the water by stirring in a solvent such as caustic soda, whereby a viscous, colloidal semi-fluid glue is formed having substantially the properties of animal glue for veneering. Some heat may be used in making the solution, in which case the amount of alkali used may be decreased."

WATERPROOF
CASEINS AND
BLOOD ALBUMIN
GLUES.

Ordinary glues were not equal to the demands of war time airplanes, and as a result the development of waterproof glues, especially for veneer parts of airplanes, received a tremendous impetus during the war. The successful airplane waterproof glues were all made either from casein or blood albumin. The wide use of these glues in the industries will without doubt result after the war in their widespread adoption for industrial purposes. Not only may they replace bone or vegetable glues for some purposes, but they make possible the use of veneered and built-up wood products in exposed locations, formerly not possible because of the lack of a suitable glue.

Casein glues in general are made from ground casein, calcium hydrate (slaked lime), and some form of caustic soda. Sometimes sodium silicate or sodium phosphate are used. Blood albumin glues are made usually from black soluble blood albumin, calcium hydrate, with a small quantity of sodium silicate, sodium hydrate, or ammonia. Often casein is mixed with the blood albumin. Casein glues set hard when

cold, and are consequently termed cold glues. They may be used in cold press equipment. Blood albumin glues depend upon the application of heat to coagulate the albumin, and hence require heated presses for their application.

Silicate of soda is successfully used as an adhesive in the paper box industry. There is a widespread feeling that it may some day be used to advantage in certain lines of wood work. Without doubt the very low cost of silicate of soda makes it an attractive material with which to experiment, and the results thus far obtained are promising.

The Bureau of Plant Industry, United States Department of Agriculture, has patented an adhesive produced by boiling corn cobs in water under pressure. The resultant solution is concentrated and used as an adhesive. The product is not as yet developed to a commercial success, but gives great promise of succeeding as a substitute for sodium silicate in the paper box industry. It is said that it will be lower in cost than sodium silicate.

WATER
GLASS.

CORN COB
ADHESIVE.



CHAPTER III.

USES OF GLUE

GLUE is used in a great variety of industries, aside from its use in joining wood. Among these may be mentioned paper sizing, where its purpose is to make the surface of paper less porous, or to give it "glaze." Animal glue, gelatine and casein are used, dependent to some extent on the relative market costs and availability at the moment, and upon the quality of the product being made.

Glue for sizing paper is usually bone glue, of high grade, free from foam, light in color, and containing no more than the normal amount of grease. It should show no perceptible odor after heating a solution in water at 100° F. for 100 hours. Alum is sometimes added to this glue by the paper manufacturer to make a free flowing solution.

PAPER
SIZE.

Paper box makers prefer a quick setting hide glue for "setting up." For "covering" a slow setting bone glue is used. Mixtures of animal glues with vegetable glues are often used, one advantage being lower cost.

PAPER BOX
ADHESIVE.

Here a product is required that is strong, flexible and free from color and odor.

BOOK
BINDING.

Straw hat manufacturers desire a hide glue free from lime, color and odor.

In wall paper, freedom from grease and objectionable odor is desired.

In match making, uniformity is desirable. The glue is used in combination with phosphorous to assist in preventing atmospheric oxidation of the phosphorous.

MISCELLANEOUS
USES.

For leather goods and belting, flexibility, tenacity and resistance to moisture are the desirable qualities in glue for leather and belting. High grade hide glues with linseed oil and glycerine added in small amounts are often used. Glycerine is said to increase flexibility, and linseed oil, resistance to moisture.

USED IN
TEXTILES.

Glue is used in dressing and finishing colored yarns and threads, sizing of worsted and woolen wraps, and in the printing of fabrics. High grade hide glues free from odor and color are required.

Tons of glue are used for writing tablets. Almost any grade, except the very poorest, will answer.

JOINING
WOOD.

A glue is valued primarily for its power of resisting rupture. This includes absence of brittleness, and it should have the power of yielding or stretching slightly before it ruptures. Glues may be found which are very strong if the strain is applied steadily, but which break under the impact of a suddenly applied load. A weaker but more elastic sample is superior to such a glue for joining wood. In general however, a glue may be valued on a basis of its strength properties.

HIGH GRADE
GLUE MAY BE
THE MOST
ECONOMICAL.

Intimately related to the strength property is the covering capacity of glue. Its value is largely controlled by these two factors. High strength usually is accompanied by great covering capacity, and hence higher priced glues may actually cost less to use than lower priced ones, which require more glue to accomplish the same purpose. Covering capacity is related to three factors—the water absorption, the jelly strength, and the viscosity of a solution of known strength. These tests made with accuracy will usually give a close indication of the grade or the value of a glue.

Color is important in some lines of wood work, being especially undesirable in high grade furniture. As a rule, however, a dark color should not be considered detrimental, as absence of color may represent high cost or the use of undesirable and weakening chemical bleaching agents.

KEEPING
QUALITY OF
GLUES.

Keeping qualities are of some importance. Alkaline glues are more liable to spoil or decompose, due to bacterial action, than acid glues. Hence a test for acidity and alkalinity give an indication of keeping properties. Glues made from partly decomposed stock do not keep well, and have a bad odor when the glue solution is heated. Hence odor has a bearing on keeping qualities.

A recent development is the use of glue as a filler in automobile tires. The lower grades of bone glue that formerly went largely to the veneer trade, are preferred. This new use of glue is of tremendous importance to the animal glue industry, especially in view of the inroads made on their market by vegetable glues. At the present time, only a few tire concerns are using glue, but the demand from this source promises to expand to very large proportions.

AUTOMOBILE
TIRES.



CHAPTER IV.

GLUE TESTING (PRELIMINARY)

A UNIFORM and generally adopted method of testing glue has never been developed, due largely to the variable and uncertain chemical composition of glue. It is exceedingly desirable for glue users to test their glues rather than trust wholly to the promises of the salesman. The technique of glue testing requires a trained observer and good equipment to accomplish very much, though there are a few simple tests and observations that can be made by any one and which will give some idea of quality.

GLUE TESTING
REQUIRES A
SKILLED
OPERATOR.

Chemical analysis of glue does not enable one to select glues according to quality, and has never been successfully applied. Glue testing consists largely of physical tests, such as viscosity, jelly strength, strength of the glued joint, ash, moisture, odor, etc.

War made necessary the development of methods of testing and specifying glue, and centered the attention of experts in this kind of work on the glue testing problem, not only in the United States, but in the European countries. The glue testing methods selected by the warring countries were naturally the best available, and hence are worthy of the most serious consideration of any reader interested in this subject. One of the most successful attempts thus far made to develop a uniform practice of glue testing was accomplished in the United States, where all glues for airplanes for both the army and navy was given a most thorough inspection. This work was done at the Forest Products Laboratory at Madison, Wis. Intensive investigation by a large force over several months on methods of testing was carried out under the guidance of a glue chemist of national reputation. All of the testing methods that might seem to have any merit whatsoever were tried. The resultant methods selected in this way were incorporated in a tentative specification which was submitted to a conference of glue manufacturers, and as finally evolved, had the

GLUE TESTING
SCIENCE
ADVANCED BY
THE WAR.

TESTS BY AN
AUTHORITY.

approval of all. They may therefore be considered as the best that this country has developed thus far.

In the following pages a few simple tests will be outlined that are possible to make without great experience or complete equipment. The more refined tests, however, require a trained analyst, familiar with the manipulation of testing apparatus, and a well equipped laboratory. The methods of test recommended by the Forest Products Laboratory are mentioned in outline only in the text, but are grouped together and given in full in the appendix.

SOME
SIMPLE BUT
SUPERFICIAL
TESTS.

Glue should not become damp or sticky (hygroscopic) in the air, or it may mold. A hygroscopic glue indicates adulteration with sugar, molasses, etc. The appearance, hardness and manner of breaking are points which may be used to judge quality after some experience. Some glues may have a cloudy or milky appearance, due to the presence of calcium phosphate. Glues of excellent strength may be warped or twisted, and very dark in color. Ground glue should not lump together in warm, humid weather.

Samples should be taken from several parts of the package, as glues are very often blended from more than one run and the mixing may not have been thorough. Special attention should be given ground glue, which is very easy to adulterate. White bubbles on the surface of the glue are an indication of decomposition. With such samples be sure to test the odor, as described later. Decomposed or sour glues are to be avoided. Bubbles appearing deep in the glue are not necessarily an indication of putrefaction. An expert glue buyer is able to judge somewhat by examining a flake of glue by looking through it at a strong light.

Gloss on the surface does not necessarily indicate high quality. On the contrary, low grade glues may be highly glossed, while good quality glues may be dark, though the surface should be smooth. A uniform color and surface appearance is desirable.

SIGNIFICANCE
OF COLOR.

Color is not a reliable indication of quality. The first runs of glue from the glue stock are lighter in color than the last ones. But it is easy to clarify glues

chemically, greatly weakening them in the process. Bone glues are usually darker than hide glues, unless they have been bleached. With any particular lot, non-uniformity of color indicates either adulteration or blending. The addition of zinc oxide gives a white opaque glue, and one that sets quickly. It is also said to add somewhat to its water resistance. In moderate quantities zinc oxide is not injurious. Sometimes inert matter of no value is added as an adulterant. Hence the color of such samples may well be reason for suspicion.

Breaking a sample of the glue with the thumb and forefinger of each hand gives an indication of glue quality. The condition of the air must be considered, as a dry day will give a different indication than a humid one. If the glue fractures evenly and bends but little, low strength and brittleness are indicated. If a thin sheet bends well and in case it breaks, shows a splintery fracture, good strength is indicated. Bone glues show a glossy fracture; hide glues of high grade never do.

SIMPLE TEST
FOR QUALITY.

Foam in a glue is undesirable. A solution of glue in water may be stirred vigorously, with a rod, or better, with an egg beater, and a fair indication of its foaming properties will be obtained. Particular attention should be paid to the rate at which the foam subsides. If it persists for long, the glue should be avoided.

Odor is a sign of poor keeping quality. Usually offensive odor is the result of using spoiled or decomposed stock, or else it may mean that the glue itself has started to decay.

ODOR SHOULD
BE SWEET.

Something may be learned by smelling of a moistened flake of glue warmed in the hand. A more reliable method is to heat a solution of glue in water, about 1 part glue to 12 of water, at a temperature of 100° for 48 hours. It should remain sweet during this period. A similar sample should be able to stand at room temperature for four or five days without developing a bad odor, or showing the presence of mold or decomposition.



CHAPTER V.

GLUE TESTING*

WHILE the tests just described are useful guides in purchasing glue in the absence of better methods, they are, at best, a makeshift. Wherever possible advantage should be taken of more refined methods.

SINGLE
TESTS ARE
MISLEADING.

The reader should, however, have a rather clear idea of the limitations of glue testing. It is usually not possible to obtain a very clear idea of glue value from any single test that may be applied. In an article describing the testing and grading of glues, the following statement is made by E. G. Clayton (Jour. Soc. Chem. Ind., 1902, 21, 670):

“In conclusion, the observations seem to show that while it would be rash to form a judgment on glue from a single test, the evidence afforded by a number may be irresistible. The expert’s surest system appears to be not to rely on single short cut tests of general quality, but to employ a number of methods, including any having especial bearing on the prospective or present uses of the glue, and then to base his conclusions on a consideration of all the results together.”

Ordinary glue of good quality contains from 8 to 16 per cent. of water. Too much water indicates poor keeping quality, and of course means that the buyer is paying for that much water. Too little water may indicate an over-dried glue, which is injurious to its strength properties. Moisture as low as 5 per cent. is not uncommon, but a good glue should have not less than 8 per cent.

MOISTURE
DETERMINATION

Moisture is determined by heating a ground sample at a temperature of 110° C. to a constant weight. The sample being hygroscopic, must be cooled in a desiccator.

After making the moisture determination, the same sample may be used for determining ash. It

ASH
DETERMINATION

*See Appendix for Forest Products Laboratory methods.

should be incinerated carefully in platinum, or preferably in vitreosil, care being taken to prevent free ignition. The ash usually varies from 1½ to 3 per cent. A fused ash indicates a bone glue, one not fused a hide glue. A large ash indicates adulteration, and a chemical examination will show what it is. Calcium phosphate is found in the ash of bone glues.

REACTION TO
LITMUS.

By its reaction to litmus a glue shows whether it is acid, alkaline or neutral. The test is made by dipping strips of red and blue litmus paper in a glue solution, and noting the color change. (The solution left after the viscosity test may be used.) An acid glue turns blue litmus red, and a neutral glue will not change the color of either red or blue litmus. Alkaline glues will turn red litmus blue. A slightly acid glue is preferable to a neutral or alkaline glue, because it is not quite so favorable a medium for the growth of the organisms which cause the decay of glue. Strong alkalinity usually means an over-limed glue, which will almost surely cause trouble.

INSOLUBLE.

To determine insoluble matter dissolve 30 grams of glue in one liter of hot water, and allow to stand for 12 hours in a warm place. Filter the hot solution through a weighed filter paper or good crucible, wash well with hot water, dry and weigh. In hide glues the insoluble matter is rarely over 2 per cent. In bone glues it may be more.

GREASE.

A little aniline color is added to the solution of glue in water (some of the solution remaining from the viscosity test may be used). The mixture is painted on unsized white paper and the appearance noted. Grease is visible in round, characteristic spots, and the relative amount present is indicated by comparison with other glues or the experience of the operator.*

WATER
ABSORPTION.

The water absorption test was proposed by Schattermann in 1845. Glue does not dissolve in cold water, but has the property of absorbing several times its weight of water. Some glues will absorb eight to ten times their weight of water and still retain a rather firm consistency. Good glues will absorb at least six

*See Jour. Soc. Chem. Ind., Feb. 28, 1906.

times their weight. A method used by the United States Bureau of Chemistry is as follows: Place 10 grams of the sample broken in small pieces in a beaker and cover with 200 c. c. of water at 15° C. Cover the beaker and place in a refrigerator for 24 hours, with the temperature between 14° C. and 18° C. Then pour off the water and weigh the glue. This determination cannot often be made above 20° C. The firmer the jell the greater the glue strength (in general), and the more water that is absorbed the greater the covering capacity of the glue. If the glue becomes slimy, or if the solution shows evidence of putrefaction, poor quality is indicated.

SIGNIFICANCE
OF THE TEST.

The melting point of the glue solution is of interest as it is a measure of how quickly or slowly the glue will set. It is sometimes used as a substitute for the viscosity test. The test is sometimes made as follows: Weigh 15 grams of the sample and soak 12 hours in a flask with 30 c. c. of water. Then immerse the flask in boiling water and shake well until the glue dissolves. While still liquid pour some of the solution into a test tube and close the end with a cork, and cool for one hour in water at 15° C. Now place in a water bath in an inclined position, with a thermometer, and gradually raise the temperature. When the glue leaves its vertical position the temperature may be taken as the melting point.

MELTING
POINT.

A simpler and more accurate method is in use at the Forest Products Laboratory. A drop of the liquid glue solution is run into a glass U tube of small size. The tube is then cooled in water for 10 minutes at 15° C. It is then placed in a water bath and the temperature raised gradually. The melting point is taken as the temperature at which the slug of glue moves downward in the U tube.

A NEW
MELTING
POINT TEST.

For information in the literature on the melting point determination see R. Kissling (Chem. Zeitung, 1901, 25, 264 and Jour. Soc. Chem. Ind., 1901, 21, 509), also N. Chercheffsky (Chem. Zeitung, 1901, 25, 413, and Jour. Soc. Chem. Ind., 1901, 25, 731).

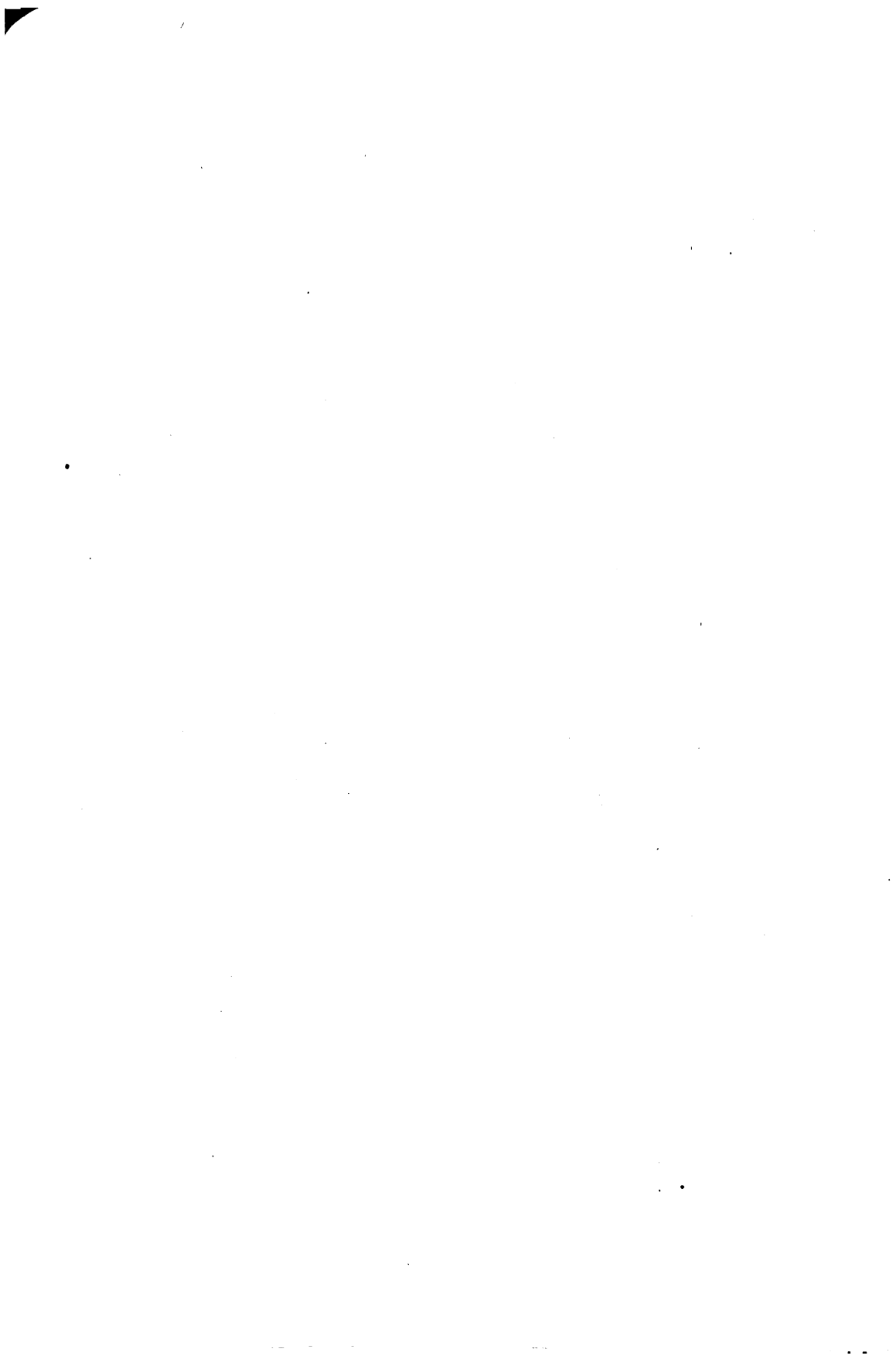

CHAPTER VI.

VISCOSITY

THIS test is one of the most important of the tests made on glue, and is in universal use by glue manufacturers. (See Fels, *Chemical Zeitung*, 1898, 9, also *Jour. Soc. Chem. Ind.*, 1890, p. 654.)

Viscosity is a term used to describe the degree of fluidity of the glue solution. The thicker the solution the higher its viscosity and the lower its fluidity or flowing power. Instruments for measuring viscosity (viscosimeters) are of various kinds. Those usually used for glue testing are of the orifice type, and depend in principle upon the time required for the passage of a known quantity of liquid through a standardized orifice, at a known temperature.

TYPES OF
VISCOSIMETERS.

Any viscosimeter of the orifice type may be used. Fels used a modified Engler (*Jour. Soc. Chem. Ind.*, 1890, p. 654), with a 15 per cent. solution (15 grams of glue in 100 c. c. of solution). Rideal preferred a type described by Slotte and modified as described in the *Journal Society Chemical Industry*, 1891, page 615. A later modification is described by Scarpa (*Gazetta Chimica Italiana*, 1910). Some observers express viscosity in the number of seconds required for the glue solution to pass through the orifice of the apparatus.

Sample No.	Description of Samples	Per cent of water in original sample.	Time of efflux of 500 CC. at 30° C. in seconds, water taking 90 sec's.	Viscosity (relative to water.)
1.	Light yellow transparent thick plates	16.3	149	1.65
2.	Brown transparent glue.....	14.0	125	1.36
3.	Sherry yellow transparent glue	15.4	171	1.91
4.	Light yellow plates.....	13.2	150	1.60
5.	Muddy (truber glue).....	15.2	199	2.21

Others prefer to express it as the ratio between the time required for the glue solution to pass through the orifice compared with water at the same temperature. Fels, with a 15 per cent. solution at 30° C., obtained the results shown in the table on page 31.

Other workers, using different instruments, obtained different figures. The value obtained depends upon the form of the apparatus and the size of the orifice.

For comparative purposes only, a home made device may be used.

A POPULAR
RAPID TYPE OF
VISCOSIMETER.

One may be made from a volumetric pipette, fitted with a stop cock. The lower end is heated in a glass flame and carefully reduced in size until its inside diameter is of the desired size. One recommended by Jerome Alexander (Jour. Soc. Chem. Ind., 1906, p. 159) is made from a 45 c. c. pipette, and will pass 45 c. c. of water at 80° C. in 15 seconds. It has the following dimensions:

Capacity, 45 c. c. of water at 80 degrees C.	
Internal diam. of effluent tube.....	6 mm.
External diam. of effluent tube.....	9 mm.
Length over all of effluent tube.....	7 cm.
Smallest diam. of outlet (about).....	1.5 mm.
Outside diam. of bulb.....	3 cm.
Length of bulb.....	9.5 c.
Length of upper tube.....	22 cm.

This pipette is surrounded with a water bath, and the flow of solution is controlled with a pinch cock and rubber tube fitted over the top.

Some glue factories, where a great many samples have to be tested every day, use a more rapid home made apparatus, with an orifice so large that the glue solution will pass through in 10 or 15 seconds. One can be made from a pipette as described, or from a glass tube contracted at one end. For several reasons such instruments are seldom very accurate.

Better control of temperature and greater accuracy can be had with the Engler viscosimeter. This is more complicated and more expensive than the pipette or glass tube type, and is also slower to operate, but it

GREASE RECORD

NOTE

Grease is not of necessity a serious defect in Glue, except in certain specific uses. It does reduce foam and affects adhesiveness.

Date _____

Index No. _____ Glue



=====

Normal

- The white spots show the grease.
- 0 is Free of Grease.
 - 5 and under is Commercially Free
 - 6 to 20 " Normal
 - 21 to 35 " Slight Excess
 - 36 to 50 " Excess
 - 51 and over " Very Greasy

Examining Chemist

The amount of grease in the glue is indicated by the light spots.
 This sample is "Normal."

GREASE RECORD

NOTE

Grease is not of necessity a serious defect in Glue, except in certain specific uses. It does reduce foam and affects adhesiveness.

Date _____

Index No. _____ Glue

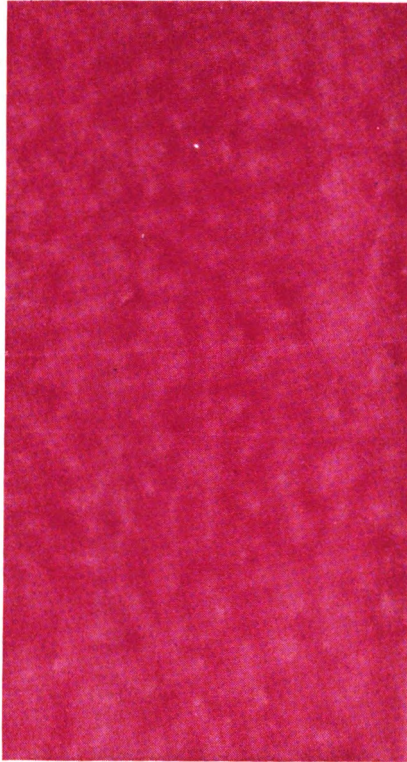

=====
Very
Greasy _____

The white spots show the grease.

0 is Free of Grease.

5 and under is Commercially Free

6 to 20 " Normal

21 to 35 " Slight Excess

36 to 50 " Excess

51 and over " Very Greasy

Examining Chemist

The large number of white spots shown in this sample indicate "Very Greasy" glue.

has the advantage, in addition to greater accuracy, of being an instrument which is in general use for testing many kinds of materials. The values obtained by its use are readily understood by laboratory men and can be readily checked. It can be purchased from supply houses standardized and ready for use. The Engler viscosimeter is in use at the Forest Products Laboratory, and is required by the specifications for glue of the army and navy. It is recommended for standardized work on glues.

ENGLER
VISCOSIMETER
IS
RECOMMENDED.

The viscosity determination is made at the Forest Products Laboratory as follows: One part of glue by weight is dissolved in 5 parts of distilled water by weight. The sample is strained to remove insoluble matter, and the viscosity determined in an Engler viscosimeter within five minutes after the sample has been melted. The viscosity is expressed in terms of the number of seconds required for 200 c. c. of glue solution at a temperature of 60° C., to pass through the standard orifice of the viscosimeter, compared with distilled water at the same temperature.

The precaution of straining the glue before testing should not be overlooked. Insoluble matter may clog the orifice and materially affect the result.

The viscosity test is of great value in grading glues, and is one of the most important tests that is used. In general, viscosity is a gauge of glue strength, high viscosity corresponding to high strength. It would lead to great error, however, if complete reliance were placed on the results of this test. It should only be considered in conjunction with other tests. Glues produced from the same stock, under identical conditions, may be graded on the viscosity test. But glues under test may have been produced from different stocks by different methods. Hence considerable error may be found by relying on viscosity alone.

SIGNIFICANCE
OF VISCOSITY
TEST.

Acid treated bone glues give viscosities very low in proportion to their jelly strength. Opaque and colored glues give higher viscosities than clear ones of corresponding strength. Glue stock incompletely washed, or over-limed gives a high viscosity. Some clarified glues have a low viscosity, both bone and hide.

Or if clarified with alum, the viscosity will be too high. Rabbit glues are liable to have viscosities that are too high to correspond with their jelly strength. The apparatus used may also lead to slight errors, as glues do not always grade the same when tested with different instruments.

CHAPTER VII.

JELLY STRENGTH

ONE of the most significant and important of the tests commonly made on glue is an estimation of jelly strength. It was suggested by Lipowitz in 1861 and has been extensively adopted. It is made on a solution of the glue in water cooled to a jelly in a refrigerator, and consists in an estimation of the strength or firmness of the jelly. In spite of numerous attempts to develop apparatus for obtaining a measure of jelly strength in terms of some tangible numerical unit, the finger test is still favored by those most expert. The finger test is akin to tea or wine tasting in that it requires long experience and great skill to obtain good results.

THE FINGER
TEST FOR JELLY
STRENGTH.

The finger test is made on a 25-gram sample soaked in 300 c. c. of water at room temperature. Melt and stir the solution, and place in a refrigerator for at least 15 hours at a temperature between 5 and 10 degrees C. (40 to 50 degrees F.) Test either in the refrigerator or immediately after removal. The operator uses the third finger of the left hand and measures the resistance by pressing on the glue jelly. Any difference between different samples is noted, and the samples may be grouped in accordance with this resistance.

In the Lipowitz test a small pointed plunger with a funnel at its upper end is inserted in the jelly. The funnel is loaded gradually with shot until the load is just sufficient to force the plunger entirely through the jelly from its top surface to the bottom of the cylinder. The weight of shot necessary to effect this gives the Lipowitz number.

THE LIPOWITZ
TEST.

An apparatus invented by Edmund S. Smith is on the market which makes jelly tests without breaking the surface of the glue. It does not give good results on extremely high or low grades. It is rather complicated, and requires frequent cleaning and attention. It consists in principle of a thistle tube, over which is

THE SMITH
JELLY TESTER.

stretched a thin sheet of rubber. At the other end of the tube is a bulb for obtaining air pressure, and a sensitive pressure gauge or water manometer. The pressure tube is also filled with water. The observation is made by forcing the rubber diaphragm into the glue jelly with air pressure from the bulb. The measurement of jelly strength is made by noting the pressure on the gauge or manometer, and the amount that the diaphragm is forced into the glue is measured or controlled by a reading of the water level in the pressure tube. The jelly strength is measured on the gauge or manometer. The apparatus must be adjusted uniformly on the different samples to be tested, and the distortion of the diaphragm must be the same in each test. The apparatus is covered by patent No. 911277.

Jerome Alexander (Jour. Soc. Chem. Ind., 1906, 25, p. 160) describes a device "consisting of a brass cylindrical vessel supported like a gas tank by four vertical rods, against which it slides with almost frictionless roller bearings. This brass cup is allowed to rest on a truncated cone of jelly of definite size, composition and temperature. Shot is gradually poured into the cup until a definite expression of the jelly is observed. Beneath the cup are two vertical adjustable brass uprights 3.5 c. m. high, connected with an electric bell circuit. When the cup reaches their level the bell rings. The weight of the brass cup, plus the weight of the shot, gives a figure which expresses the jelly strength."

After thoroughly testing most of the above methods, as well as numerous other ones, an apparatus was adopted at the Forest Products Laboratory that is described in the appendix. This apparatus was modified from one in use in the glue laboratory of Armour & Co., Chicago. (See Appendix.)

The jelly test, together with viscosity, are the most important of the tests made on glues, and all other tests must be considered in conjunction with them if the operator is to form a true conception of the grade of the glue sample. Both tests must always be made to obtain a fair comparison between an unknown

sample and one of Peter Cooper's standard. To say that a glue tests 1 Extra means that its jelly strength and its viscosity must be the same as a standard sample of Peter Cooper's 1 Extra. Obviously, the operator must secure standards of known strength before he can rate his glues, as it is practically impossible to define a method of test and an apparatus with sufficient exactness that the glue may be rated without the use of standards of comparison. Therefore it is of the utmost importance that the operator secure or have in his possession standards of known value before he can rate and value the unknown sample. Peter Cooper standards may be purchased from the Peter Cooper Glue Company.

In making jelly strength tests it is well to remember that sulphates in the glue increase the jelly strength (as well as viscosity), while chlorides and nitrates diminish it.

GLUE STANDARD
SAMPLES ARE
NEEDED.

CHAPTER VIII.

STRENGTH OF THE GLUED JOINT.

EVERY user of glue in wood work is interested in the strength of the glue. Hence numerous efforts have been made to devise tests that would measure the strength of the glue in the joint. The literature is full of descriptions of tests of one sort or another, and quite frequently statements are found to the effect that the results obtainable are variable or unreliable. Many thousands of tests have been made at the Forest Products Laboratory, Madison, Wis., and as a result of these, the author is forced to admit that most of them do not measure the strength of the glue, but rather are a measure of the quality of workmanship or skill of the operator in making the joint. With the utmost skill and the best methods of workmanship, it is possible to produce joints with grades $1\frac{1}{4}$ or higher that will always break the wood. Possibly the grade of $1\frac{3}{8}$ may be the dividing point. Dense maple, chosen because of its great shear strength, was used in these tests. Some information on grades below $1\frac{3}{8}$ may be obtained by strength tests. Usually specimens glued in the factories or by the average carpenter fail in the glued joint—many hundreds of such have been sent in for testing. But the same glues can be made to give a joint so strong that wood failures result. The best joints made by carpenters and workmen have been produced with grades about Peter Cooper No. 1. Glues grading higher probably set too fast, and since the workman does not often produce a joint 100 per cent. perfect, those grading below that do not develop the full strength of the wood.

The glue chemist should have a rather clear understanding of the fundamentals of testing glue joints, or he may draw erroneous conclusions from his results. He is possibly more liable to be measuring his own ability to do "stunts" with the glue rather than measure the strength of the glue. In any case, with grades above $1\frac{3}{8}$, watch yourself closely. The strength

JOINT
STRENGTH
TESTS MAY BE
DECEPTIVE.

test has been very useful in obtaining data on the effect of various operations, such as time of pressure, etc., on the strength of the glue joint. It is also true that a good strong joint cannot be obtained with a glue that lacks adhesiveness.

THE SELECTION
OF WOODS FOR
GLUE TESTS.||

In order to develop as nearly as possible the full strength of the glue it is necessary to use wood of good gluing qualities and of high shearing properties. Not all species meet these requirements. The following table, based on tests on small clear specimens of material, gives a number of species which have an average unit value in shear parallel to the grain of over 2,400 pounds per square inch at 8 per cent. moisture, as well as a number of other common species with shearing strength below this value.

In general the shearing strength of wood when the surface of failure is tangential is about 8 per cent. greater than when the surface of failure is radial. This

SHEARING STRENGTH OF WOODS AT 8 PER CENT
MOISTURE WITH SPECIFIC GRAVITY VALUES

Species	Specific gravity oven dry based on volume		Shear parallel to grain surface of failure		Aver- age
	When green	oven- dry	Ra- dial*	Tan- gen- tial†	
Ash, white (forest grown)	.52	.60	2331	2021	2176
Beech	.54	.66	2256	2397	2326
Birch, sweet	.59	.70	2873	2811	2842
Cherry, black	.47	.53	1780	2294	2037
Dogwood (Flowering)	.64	.80	2680
Gum, red	.44	.53	1734	1900	1817
Hickory, big shellbark	.62	2510	2536	2523
Locust, black	.66	.71	2516	3391	2954
Locust, honey	.60	.67	2391	2514	2452
Maple, sugar	.56	.66	2602	3030	2816
Oak, Canyon live	.70	.84	2370	2628	2499
Oak, Commercial red	.56	.67	1906	2263	2084
Oak, Commercial white	.59	.71	2136	2466	2302
Persimmon	.64	.78	2185	2671	2428
Walnut, black	.51	.56	1273	1552	1412
Yew, western	.60	.67	2326	2861	2594

* By radial surface of failure is meant a plane of failure perpendicular to the growth rings.

†By tangential surface of failure is meant a plane of failure parallel or tangent to the growth rings.

||From paper by L. J. Markwardt, Forest Products Laboratory.

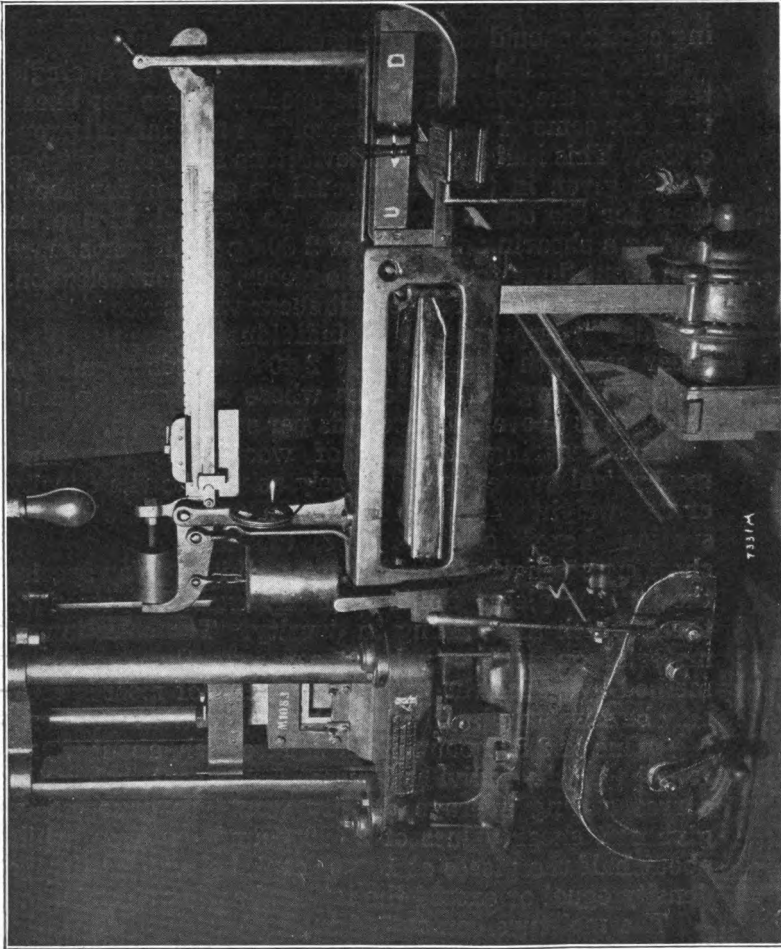

Fig. 1. 20,000 lb. Rhiele Testing Machine used at Forest Products Laboratory, Madison, Wis., for testing the shear strength of glue joints.

**SHEARING
STRENGTH OF
WOOD.**

indicates that higher values would be secured from most species by making the surface of failures tangential, but in some species the reverse appears to be true. The radial shearing strength would be influenced to a considerable extent by any season checks which may exist in the material, and consequently any material containing checks should be eliminated.

**VARIATION IN
STRENGTH
OF WOOD.**

The probable variation of the results of a single test from the average of the species is less for shear than for some of the other important mechanical properties. This indicates that deviations from the average values given in the table would be smaller for shear than for the other properties. In general, in species having a shearing strength of 2,600 pounds per square inch about three-fourths of the pieces, without selection, would be expected to give unit shear values above 2,400 pounds. The proportion of individual pieces having a shear strength greater than 2,400 pounds would, of course, be larger for species whose average shearing strength is above 2,600 pounds per square inch.

The shearing strength of wood, like the other mechanical properties, is closely related to the density or dry weight of the material. In general the lighter species, therefore, are inferior to the denser ones in shearing strength, and, likewise, within a given species the heavier pieces would normally exceed in strength those which are lacking in density. The selection of material on a density basis consequently presents a method by which the poorer specimens of most species may be eliminated. In species having an average shearing value of 2,800 pounds per square inch, about three-fourths of the individual pieces 5 per cent. below the corresponding average density would be expected to give unit shear values of 2,400 pounds or over, while about half the pieces at 10 per cent. below the average density equal or exceed the latter shearing stress.

The moisture content of the wood when below the fiber saturation point* is another factor which influ-

*The fiber saturation point is that point at which no water exists in the pores of the timber, but at which the cell walls are still saturated with moisture. The fiber saturation point varies with the species. The ordinary proportion of moisture, based on the dry weight of wood, at the fiber saturation point, is from 20 to 30 per cent.

ences the strength, the strength increasing with decrease of moisture. In general, a moisture content above this point does not affect the strength. The material for gluing should, therefore, probably be at least as low as 13 per cent. moisture.

EFFECT OF
MOISTURE ON
STRENGTH.

While a number of species have very high shearing values, several other points must be taken into consideration in selecting material for glue tests, such as the property of taking glue, and availability. Sugar maple has been found to give very good results, is easy to procure, and when straight grained and free from defects is recommended as a shearing material for glue tests. Sweet birch would likewise be expected to prove satisfactory for this purpose.

The question of the significance of joint strength tests made on grades better than 1 $\frac{3}{8}$ has already been raised. It has been found that joints made at just the instant the glue begins to chill are very strong. It is almost impossible to always have the glue film of the same thickness in successive test pieces, and the thickness of the film very markedly affects the joint. Above all avoid a film too thin (a starved joint). A starved joint can be obtained by using too much pressure. It will be obvious that before the operator can feel that the results of his strength tests are reliable he must know all the essentials of producing a perfect joint, and be perfectly certain that he has succeeded in doing so. He is advised to do considerable experimenting with joints made under different conditions before relying upon his results.

VARIATION IN
APPLICATION
OF GLUE AND
MANUFACTURE
OF JOINT.

REQUIREMENTS
FOR OBTAINING
MAXIMUM
STRENGTH.

This more properly resolves itself into a discussion of methods of testing. It is of course possible to obtain some information from almost any sort of strength test that will rupture the glued joint. Thus the workman may try to split the joint with a chisel. If it follows the glue, either he has a poor joint or the glue is weak. Such tests are relatively of very little value, as even low grade glues may not split along the joint if a soft or weak wood is used. With very hard, strong woods it is possible to obtain an idea of the strength, but not in terms that can be readily expressed. Such tests should be carried out on strong

IMPROPER
APPLICATION
OF THE LOAD.

woods, as maple or birch. Even oak is hardly strong enough in shear to test ordinary grades of glue.

APPLY LOAD
UNIFORMLY.

When the attempt is made to measure the load necessary to rupture either the wood or the glued joint, the results are liable to be so variable as to mean nothing unless properly applied. Any test that does not apply the load uniformly over the test piece is to be regarded as of doubtful value. Such tests usually can be resolved into applying the load on the joint in shear, in tension, in cleavage or by twisting. Only the first two should be considered by the glue tester. In the latter two the load is concentrated on small areas, which give way and allow the load to then be concentrated on adjacent areas. The piece can never show its maximum strength, as it can when the load is applied uniformly.

THE
TEST

THE SPANDAU
TEST.

THE
TEST

This is a test proposed by Karmarsch and adopted by the Artillerie Werkstatte, Spandau. It has been much used in America. Cement testing machines are often used, or sometimes a system of levers is devised that works well. Samuel Rideal (Glue and Glue Testing) reports great difficulty in obtaining check results, due to non-uniformity in the wood, and in the surface of the wood at the glued joint; time of heating the glue and temperature of gluing, thickness of glue, pressure used, uneven application of pressure, presence of lumps; variation in the moisture in the air, temperature while setting, duration of time between gluing and testing; temperature while testing; uneven application of load. Truly a formidable list of causes for variation, and obviously requiring skill and knowledge of the subject to secure consistent results.

The Spandau test, as officially adopted in Germany, consists in gluing together two blocks of wood with a plain butt joint with the grain end to end. The blocks are 40 mm. square in cross section, and 210 mm. long. The glue stock is prepared by dissolving 250 grams of glue in 500 c. c. of water. The blocks having been glued together, one is fixed horizontally to a table in such a manner that the joint between the two blocks overhangs beyond the edge of the table. A scale pan is attached to the block at a given distance beyond the

edge of the table and weights are added until the joint fractures.

This test cannot be recommended very highly, because it places the top of the joint at a maximum strain, while the bottom is in compression. A uniformly applied load is much superior.

A test adopted by the British Royal Aircraft factory in their specification of Nov., 1916, uses a double wedge shaped block (See Fig. 2). It is made by gluing together two pieces of American walnut.

BRITISH BLOCK
AIRCRAFT TEST.

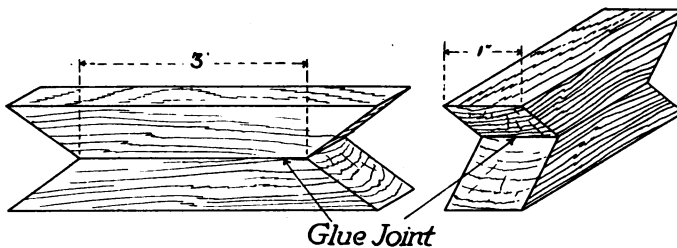

FIG. 2

The glue solution is prepared according to the glue manufacturer's instructions. The test joint has dimensions 3 in. by 1 in., and is required to support a static load of 187 pounds per square inch in direct tension. The test is made at 122° F. at normal humidity, in a fully saturated atmosphere, and submerged in water. The load must be supported for various lengths of time in these tests, depending upon the grade of glue desired.

The Aeronautical Inspection Directorate (England) tests a sample of the form shown in Fig. 3.

American walnut is used and the glued surfaces

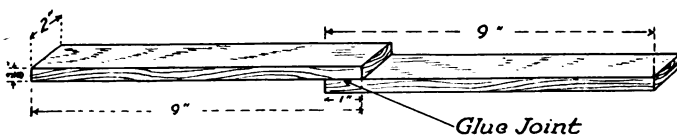

FIG. 3

**ANOTHER
BRITISH TEST.**

slightly tooth-planed. The specimen is supported at the ends in a testing machine and the load applied in the center. Precautions are specified for the temperatures, pressures used in gluing, preparation and application of the glue, etc., that insure reasonably uniform results. The fundamental objection is that the load is not uniformly applied to the glued joint. Fairly consistent results may be obtained, however.

Of the numerous methods experimented with at the Forest Products Laboratory, Madison, Wis., the tension test and the shear test were the only ones that gave reasonably accurate results. The tension test was discarded because it does not represent the most common practice of gluing wood, and is furthermore inconvenient and slow. It can, in one form or another, however, be satisfactorily used to determine glue strength.

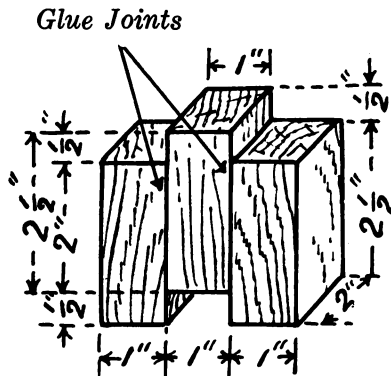

FIG. 4

A test specimen as shown in Fig. 4 has been widely used*, but was discarded at the laboratory. This specimen is made of three pieces glued in the form shown, with 4 square inches in each joint. The specimen is placed in the testing machine and tested in compression. This test appeals to people because it does not require a tool or special device to test in a testing

**AVOID THIS
METHOD.**

*See Jerome Alexander (Jour. Soc. Chem. Industry, 1906, 25, 160).

machine. It is not recommended, however. It is mentioned here because of its rather widespread use, and the temptation to use it in the absence of complete equipment. The objection lies in the fact that when the load is applied, the two outer pieces spread apart at the bottom, giving a failure in cleavage instead of in shear. The test as finally adopted at the Forest Products Laboratory uses a specimen as in Fig. 5. The

U. S. ARMY
AND NAVY TEST.

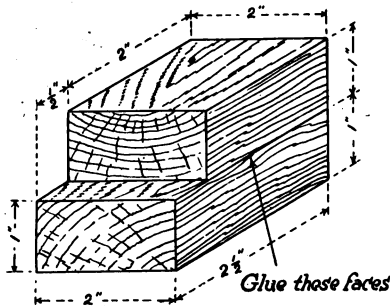

FIG. 5

wood is prepared conveniently as in Fig. 6, which is self explanatory. It is necessary to use a shear tool. A drawing of this is shown in Fig. 7. Fig. 8 shows a specimen under test in the testing machine.

A complete description of the Forest Products Laboratory method is given in the appendix. A modification of this method has been used to some extent by sawing the specimen as shown in Fig. 9.

This specimen is then tested in compression without the use of a shearing tool. The author cannot vouch for this method, as he has never used it.

A rather common method of glue testing is to cut a series of boards as shown in Fig. 10. These boards are glued together as the vertical straight lines indicate. After the glue has set, a wedge is driven in at the places indicated by the arrows. The claim is made that a good grade of glue should always hold the pieces together so firmly that the glue joint does not give way, but that the wood itself will split or be

A SIMPLE BUT
INACCURATE
METHOD.

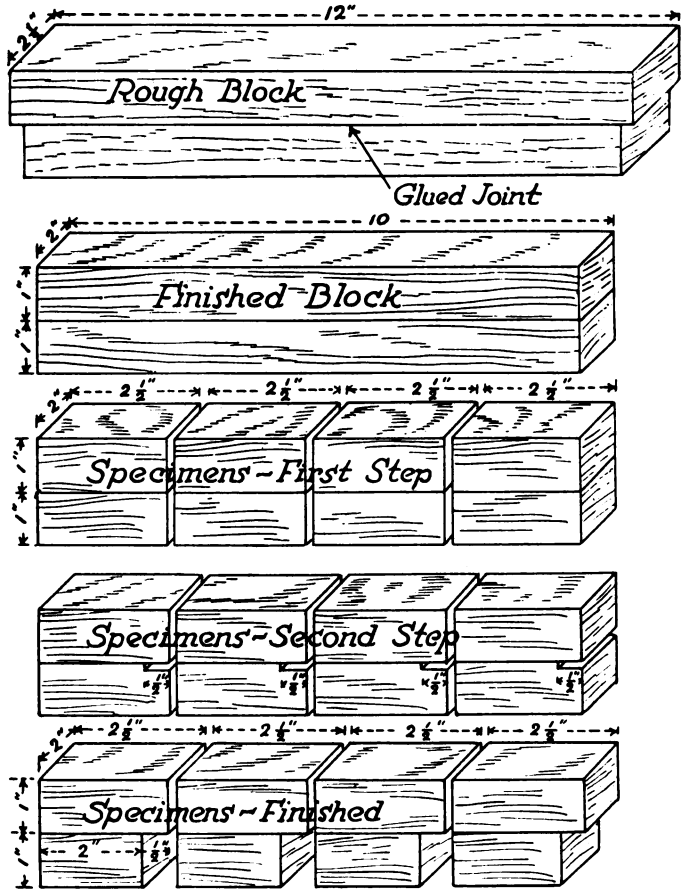

METHOD OF PREPARING SPECIMENS
FOR
GLUE STRENGTH TESTS

FIG. 6

ruptured. This method is guesswork and yields no results for the reason that no matter how much the strength of the wood may vary, the test does not indicate this variation. Furthermore, the result cannot be expressed in figures.

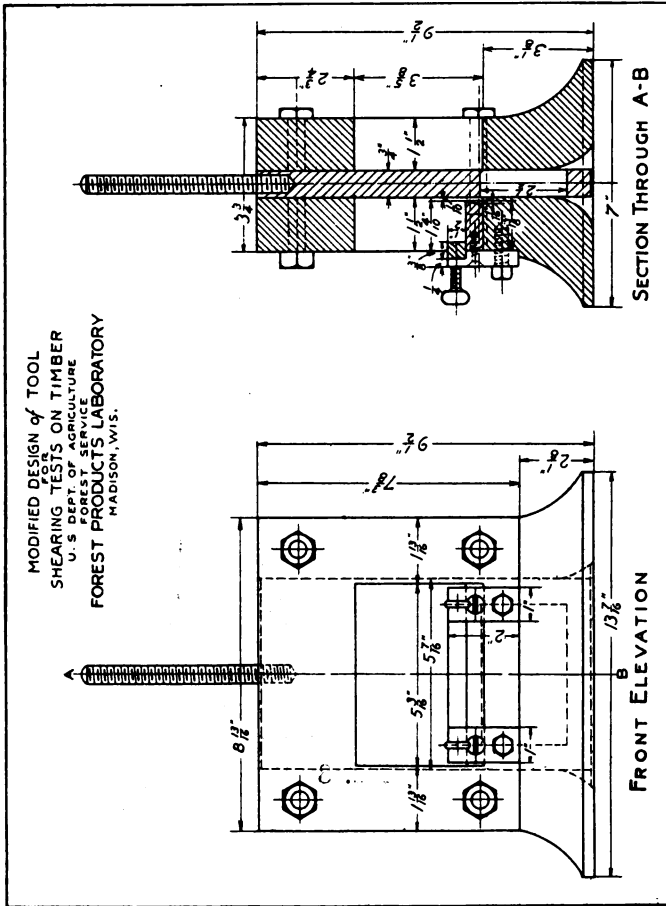

Another common method is to glue up two pieces from 10 to 12 inches in length and of suitable width to fit into a bench vise. After the glue has dried, the glued boards are placed into the vise so that the

entire joint stands out from three to four inches. The workman strikes the joint with a hammer, and it is claimed that if the glue joint is weaker than the wood the joint will break; if not, the wood will split. The results obtained in this test are absolutely worthless.

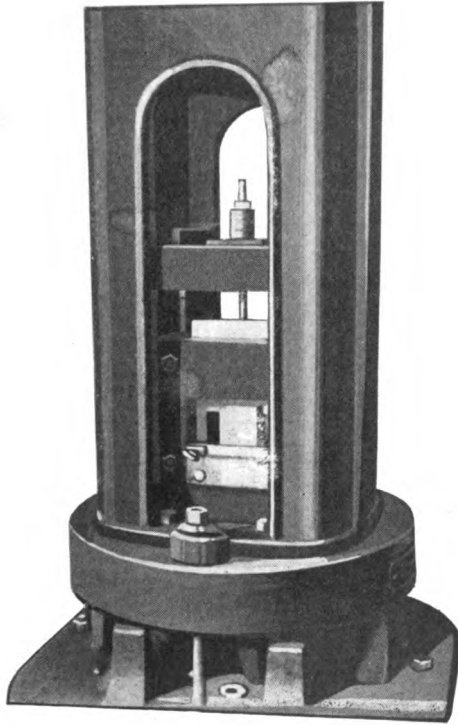

FIG. 8

Figure 11 shows a simple scheme that will likely appeal to some.

The heavy straight vertical line represents a wall or post. *A* represents a heavy hinge being fastened to the wall and beam *B*. *C* represents a block, the end being rounded so as to fit part way into the "V" cut opening of the glued test piece *E*. *D* represents the platform of a so-called platform scale. The beam

is 10 feet long by 4 inches by 2 inches. The test piece is usually 10 inches by 3 inches by $\frac{7}{8}$ inch each, two pieces glued together and the top cut out either "V" or "U" shaped. *C* is placed in the opening; this block, as the illustration will indicate, being a little larger than the slot into which it is fitted. The weight on the end of the beam required to break the pieces is read and recorded.

THIS METHOD
MAY BE BETTER
THAN NO TEST.

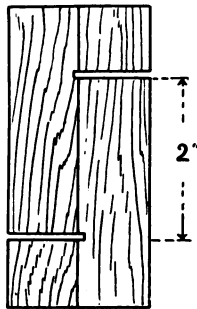

FIG. 9

A simply made lap joint test is worthy of mention.

Carefully selected pieces of a hard wood are used for this test. The moisture content is determined. The pieces are jointed and sized, so that they will be exactly 8 inches long by 1 inch by 1 inch. The thickness and width should be determined with a micrometer. The pieces are then lap-glued as per illustration,

THIS IS A
FAIRLY GOOD
HOME-MADE
DEVICE.

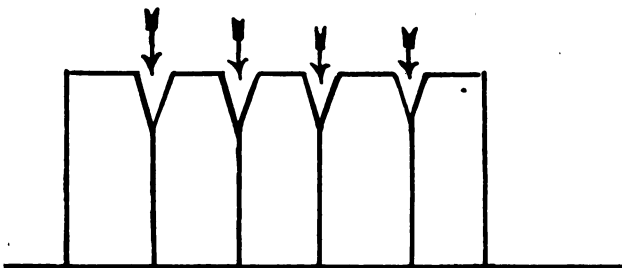

FIG. 10

and we now have a glued surface of exactly one square inch. In studying Fig. 12 the reader will observe blocks *B*. They are glued into the corners of the testing machine, one being 2 inches, the other 1 inch thick. *Par.* represents a partition or wall through which the plunger *P* passes. *P* is a stick of wood one inch square of convenient length to which *T*, a support for the weights, *W*, is fastened.

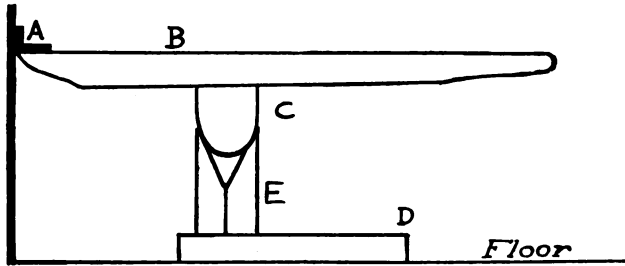

FIG. 11

The glued pieces are stored in a dry room for from three to four weeks. The test strips are next placed in the testing machine upon blocks *B*. Weights are added on *T* until the lap breaks, and the weights to accomplish this are recorded. The objection to this method is that the load is not applied uniformly over the glued joint.

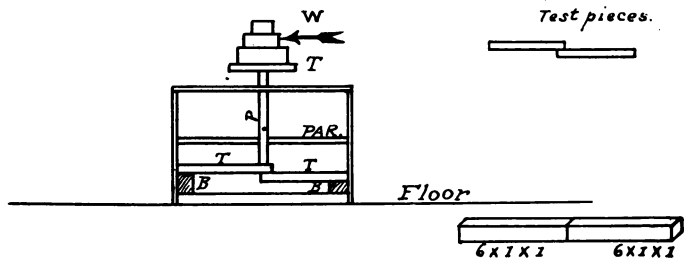

FIG. 12

The difficulty of obtaining satisfactory results from strength tests on glued wood joints has inevitably led investigators to try other schemes for testing strength. The experience of the Forest Products Laboratory has led them to feel that schemes for testing the strength of the film, or of some porous material such as plaster or earth cemented together with the glue may have merit.

MISCELLANEOUS
STRENGTH
TESTS.

A method of glue testing suggested by Karmarsh and modified by Weidenbusch, 1859, consists in breaking small rocks of plaster of paris cast in molds of uniform size and saturated with glue solutions of known strength and dried thoroughly. They are then horizontally supported at their ends and loaded in the center, the weight required to break the rod being the so-called Karmarsh, or Weidenbusch, figure for the corresponding glue solution.

A PLASTER
ROD TEST.

Setterberg (Schwed, *techniks Tideskrift*, 1898, XXVIII, 52) soaks strips of paper in the glue solution. The excess of glue is removed with filter paper, the strips allowed to dry, and tested in a paper testing machine.

THESE TESTS
WARRANT
CONSIDERATION.

Gill (*Jour. Ind. and Eng. Chem.*, Feb., 1915, p. 103) tried the tension test, gluing blocks together endwise. He also tried porcelain, glass, and tiling. He could not secure uniform results, and then dipped filter paper in the glue solution, dried and tested. His conclusions are as follows: "The method of testing glue by measuring the strength which it imparts to bibulous paper is dependable and gives fairly concordant results."



CHAPTER IX.

PLYWOOD STRENGTH TEST.*

A HIGHLY satisfactory method of testing glues in veneer panels or plywood was developed at the Forest Products Laboratory. It was adapted from the English A. I. D. method. An experienced operator can make from 500 to 1,000 tests a day. A large number of tests on each glue may thus be made, reducing the variables due to a small number of tests.

A RAPID
TEST SUITABLE
FOR VENEER
WORK.

The specimen for this test is prepared as shown in Fig. 13 and the test is made by placing the speci-

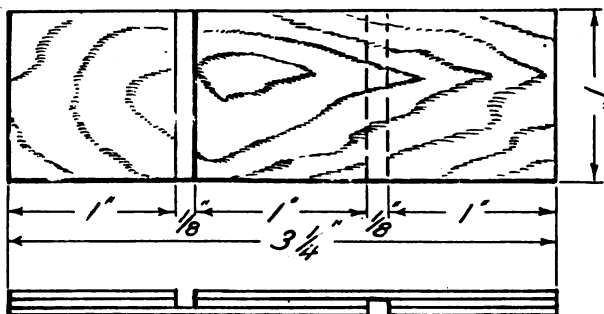

FIG. 13

men in the grips of a testing machine and exerting a pull upon it. This causes the joint to fail either in the glue or the wood, or both. The English requirement is that the glue joint in the plywood must show a strength of at least 150 pounds per square inch in this test to be acceptable. On the basis of several thousand tests on plywood secured from various American manufacturers it appeared that a minimum average of 150 pounds per square inch may also be safely required for American plywood.

*From paper prepared by Teesdale and Colgan, Forest Products Laboratory.

Fig. 14 shows the style of grips first used, as recommended by the English reports, to do away with the free pivot motion allowed by these grips a special jaw was designed as shown in Fig. 15. These jaws were in-

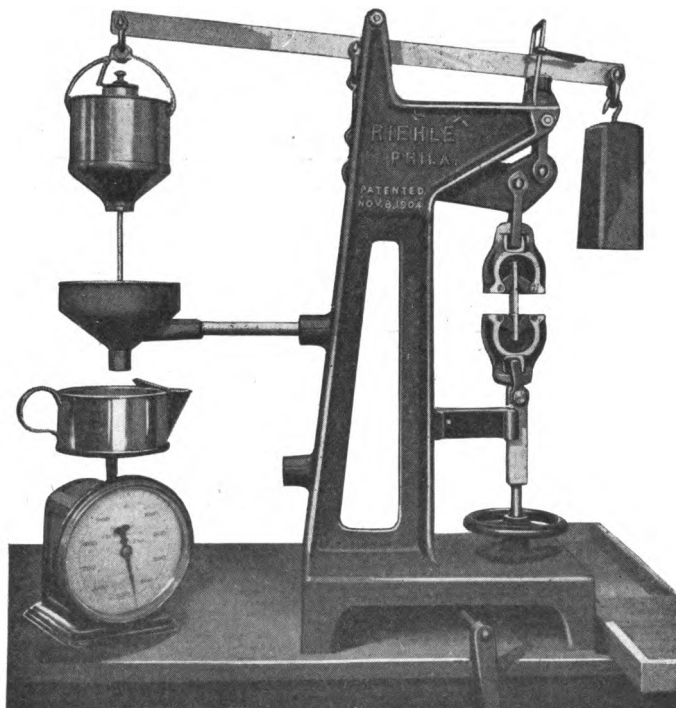

FIG. 14

serted in the Riehle cement tester as shown in Fig. 16. The upper jaw is hung on a knife edge, since it is a part of the leverage system of the balance. The lower jaw is rigidly fastened except for the vertical motion in operating the machine. A guide attached to it counteracts the tendency of the upper jaw to swing in the direction of opening of the upper saw cut.

When adjusting a specimen into these jaws the only additional precaution necessary is to make sure that

it is centered in order to get a straight pull. This is done by adjustable thumb screws which control the position of the grips.

The bucket attached to the lower arm at the left contains small lead shot, which are released by a valve-like mechanism and flow into the pan on the spring scale placed below. The load is applied to the specimen in the holder by means of the wheel at the right. As

HOW TEST IS
MADE.

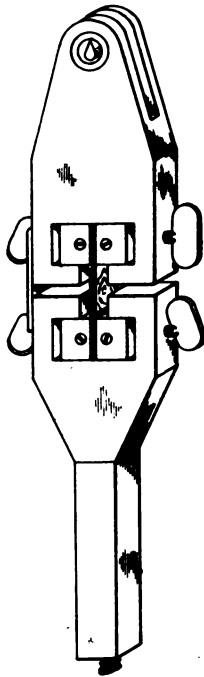

FIG. 15

the load is applied, the shot are released from the bucket and flow into the pan on the scale, which indicates the actual load applied. When the specimen breaks the flow of shot is automatically stopped.

The difference between the strength values shown in the shear test on blocks and the English test on plywood is due to several reasons. In the shear blocks,

**WHY PLYWOOD
STRENGTH
TESTS GIVE
LOW VALUES.**

the grain of the two pieces glued together runs in the same direction, while in plywood the grain of the plies runs in opposite directions. Changes in moisture content due to the drying of the glue in the joint will, therefore cause stresses in the joint in the plywood to a very much greater extent than the shear blocks, because the shrinkage of wood is much greater across the grain than along the grain. Also in making joints

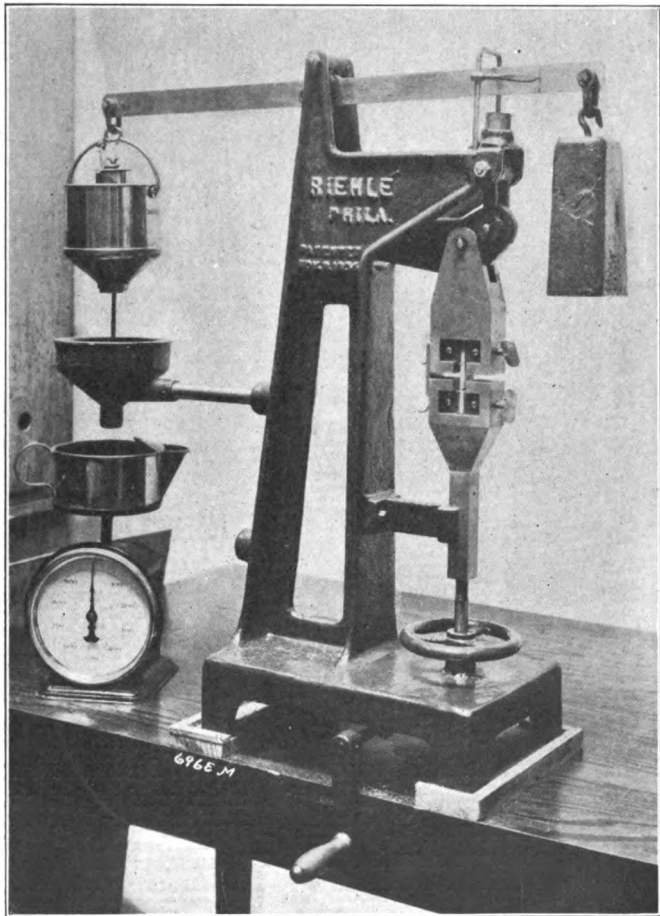

FIG. 16

in thick material greater care is possible in the preparation of the surface and the application of the glue than in plywood. The continued flexing of plywood in handling also may have some weakening effect on the glue.

The panels to be tested are cut into specimens one inch by three and one-fourth inches; the test area being restricted to one square inch by notches cut through one face and the core, on opposite sides of the panel, one and one-eighth inches from each end.

A panel should preferably be three-ply and should not have a core which exceeds one-eighth inch. Thinner cores are preferable. When thick panels are tested, it is sometimes necessary to plane them down to a thickness suitable for the machine before testing them. Panels with 1/64-in. plies are too thin to test, because it is practically impossible to make them into shear specimens without spoiling them. This test may be used to test the quality of glue or of workmanship in veneer panels. It may also be used to test the water resistance of glues by placing the test specimens in water or under humid conditions before being tested.

DETAILED
DESCRIPTION
OF PLYWOOD
TESTS.

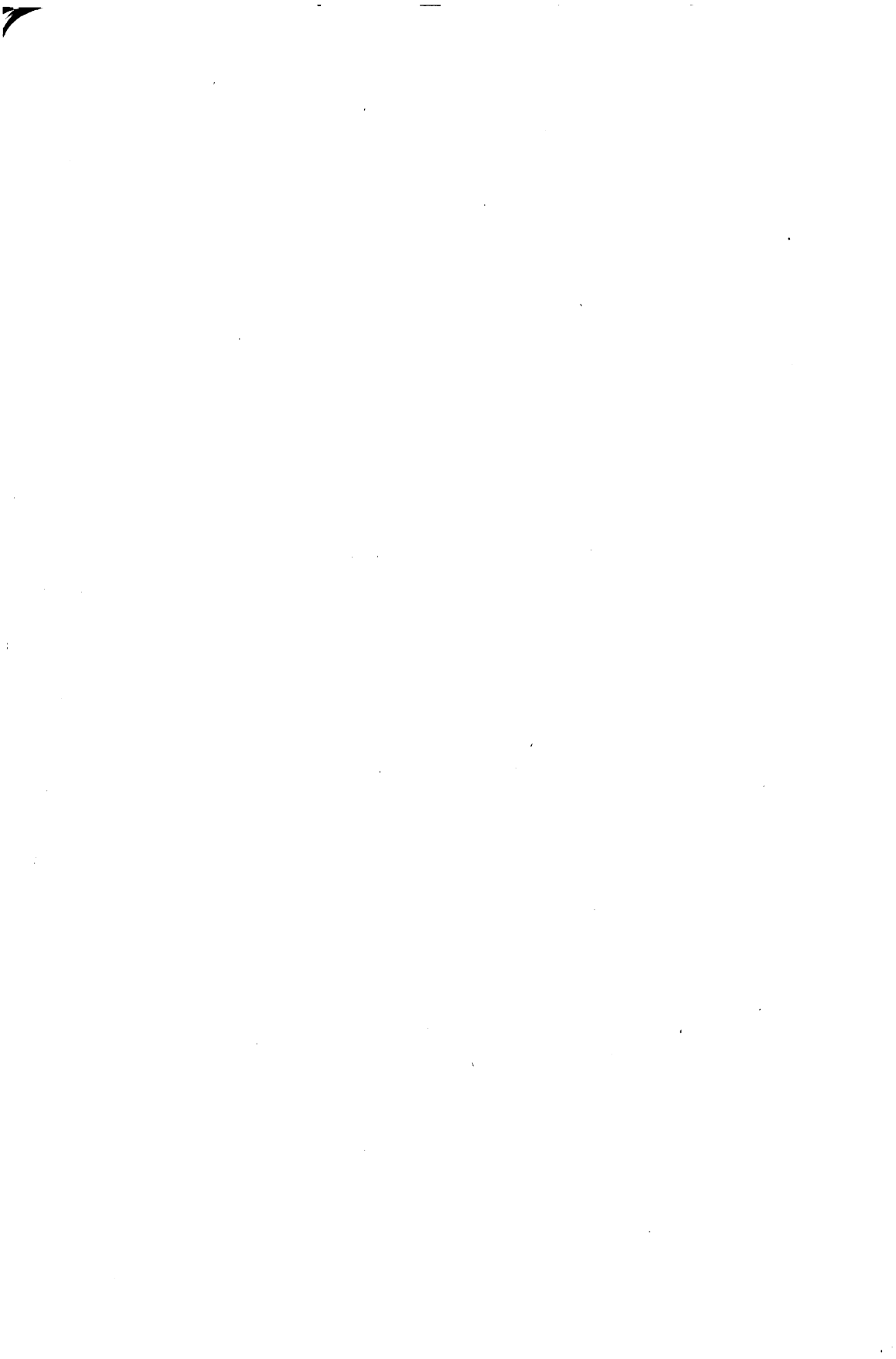

CHAPTER X.

SPECIFICATIONS.

THE readers inexperienced in glue testing may have gained the impression that the methods of test are unreliable and of little value. This is by no means the case. It is true that testing methods are arbitrary, and that they cannot in general be expressed in terms of numerical values with sufficient exactness to write a specification. It was for this reason that in the work of the Forest Products Laboratory, all thought of attempting to prepare a specification without the use of a standard sample was abandoned. The specification as evolved makes use of a standard sample which was selected as being satisfactory for the purpose, and of a grade not difficult to obtain. The specification then requires the manufacturer to furnish glue at least equal to the standard sample in jelly strength, viscosity, grease, foam and odor. After two years of use, covering purchases of over a million pounds of glue for both the army and the navy, it can be said that the specification was very satisfactory, both to the manufacturer, the consumer and the specification department. Hence it can be recommended unqualifiedly to any purchaser of glue in quantities sufficient to warrant the expense of making tests. It would only be necessary for the buyer to determine upon a standard sample of the quality he desires, and set aside a quantity, say 50 or 100 lbs., to be used as a standard sample. The specification as given would apply in all respects except "adhesiveness," where the required strength values would change with the grade of the standard sample. In these specifications the standard is about the equivalent of Peter Cooper's grade 1.

THE ARMY AND
NAVY GLUE
SPECIFICATIONS.

1. This specification covers the requirements of the Bureau of Aircraft Production for all hide glue used in the construction of propellers and for splices of airplane structural members.

SPECIFICATIONS
FOR AIRPLANE
USE.

2. The glue must be a high grade hide glue, sweet and free from any deleterious substances.

3. The glue shall be tested by comparison with a standard sample for jelly strength, viscosity, grease, foam and odor. The standard sample may be obtained from the Director, Forest Products Laboratory, Madison, Wis.

4. The following tests shall be made by a Bureau of Aircraft Production representative before certifying or accepting any hide glue for use in aircraft construction.

5. The test for adhesiveness shall be made on 4 test specimens of the form and dimensions shown in Fig. 5, page 49. The test specimens shall be made of maple having a shearing strength of at least 2,400 pounds per square inch. This will require wood having a dry weight of about 50 pounds or more per cubic foot, and a moisture content of from 8 to 12 percent.

STRENGTH
TEST, U. S.
ARMY.

6. The glue shall be mixed with water in four different proportions by weight, and test specimens shall be prepared using the glue at each of these four dilutions. Unless otherwise specified, the proportions used shall be as follows:

	I.	II.	III.	IV.
Water	1	2-¼	2-½	2-¾
Glue	1	1	1	1

The glue shall be added to the water at room temperature, stirred thoroughly, and allowed to stand for at least two hours. It shall then be melted in a water bath, at 140 deg. Fahr. (60 deg. C.) and applied to the wood surfaces which are to be placed in contact. These surfaces shall fit perfectly together, and the wood shall be at room temperature. After gluing, the test blocks shall be held under a moderate and uniform pressure for 15 to 24 hours. At the end of this time they shall be released from pressure without subjecting them to shock, and allowed to stand for 6 days additional. The test specimens shall be finished so that when they are ready for testing they shall have a glued joint two inches square, and conform to Fig. 5. The specimens shall be tested to destruction in a test-

MODE OF
PROCEDURE.

ing machine approved by the Inspection Department. No test specimen shall fail under a load of less than 2,200 pounds per square inch, and the average shearing strength shall be at least 2,400 pounds per square inch. Specimens which fail under a load of less than 2,400 pounds per square inch will, if the failure occurs entirely in the wood, be excluded in calculating the average shearing strength and the permissible minimum. The glue mixed with water in at least one of the four proportions as above shall comply with this strength requirement. The dilution at which the greatest strength is indicated will be recommended for use.

7. The jelly strength shall be determined upon a mixture containing 12 parts of water to 1 part of glue. The glue shall be soaked, melted and poured immediately into a vessel of standard size and shape. It shall then be allowed to stand for at least 15 hours in a refrigerator at a temperature of from 40 to 50 deg. Fahr. (5 to 10 deg. C.). The relative strengths of the standard sample and the glue under test will be determined in the refrigerator, or immediately after removal therefrom, by pressure with the fingers or with some suitable apparatus approved by the Inspection Department.

JELLY
STRENGTH.

8. The viscosity shall be determined in an Engler Viscosimeter upon a sample containing 1 weight of glue to 5 weights of water. The sample shall be strained and the viscosity shall be determined within 5 minutes after having been melted. The viscosity shall be expressed in terms of the number of seconds required for 200 cubic centimeters of the glue solution, at a temperature of 60 deg. C., to pass through the standard orifice of the viscosimeter.

VISCOSITY.

9. The relative amount of grease present shall be determined by mixing a dye with some of the glue remaining from the viscosity test, painting the mixture on unsized white paper, and observing the appearance.

GREASE.

10. The test for foam shall be made on the sample used in the viscosimeter. The sample, after heating to 140 deg. Fahr. (60 deg. C.), shall be beaten for one minute with a power egg beater, or similar instrument,

FOAM.

and allowed to stand one minute or until the foam can be measured.

ODOR.

11. The odor of the glue, when in hot solution, must be sweet and must remain sweet for 48 hours; that is, free from any suggestion of deteriorating animal matter.

INSPECTION.

12. The inspector shall have free access to all parts of the plant where this glue is being manufactured, and shall be afforded every facility to satisfy himself that the glue is in accordance with this specification.

PRELIMINARY
SAMPLE.

13. The tests shall be made on a sample from each lot of glue. The manufacturer of hide glue, when he has accumulated not less than 30,000 pounds which he considers to be in compliance with the specification, will make up a sample which shall be representative of the whole 30,000 pounds, grind it, if it is not already in the ground condition, and send at least a 2-pound sample of it to the Senior Inspector, Bureau of Aircraft Production, Forest Products Laboratory, Madison, Wis., or to a laboratory designated by the Inspection Department, Bureau of Aircraft Production. It must be plainly marked "Preliminary Sample," and it must be accompanied by a written statement as to the amount of the glue represented by the same and instructions concerning the method of using this glue which the manufacturer ordinarily furnishes the user. He shall notify the Raw Materials Department and the Inspection Department at Washington, D. C., when the sample is forwarded.

14. This sample will be tested by Bureau of Aircraft Production inspectors, and the results of these tests will be sent to the manufacturer as soon as possible.

15. If the preliminary sample passes all tests, the manufacturer may proceed to mix thoroughly all the glue represented by the sample. He will advise the inspectors at the laboratory on what date it will be ready for final mixing, inspection and barreling. As near that date as possible, an inspector will visit the glue factory. In his presence, the glue will be given

such final mixing as he deems necessary. It will also be packed in tight drums or barrels in his presence; and, at the same time, he will take a sample which will be known as the official sample. The inspector will forward this sample to the Forest Products Laboratory, or to a laboratory designated by the Inspection Department, for analysis. The results of this analysis will determine whether or not the hide glue can be certified. After the glue has been placed in barrels, the inspector will witness the "heading" of the filled barrels, and will seal both ends of every inspected barrel with serially numbered labels provided for the purpose. Each barrel shall also be marked with the name of the glue.

METHOD OF
SEALING.

Note—The submitting of the preliminary sample is not required and may be omitted if so desired by the manufacturer.

16. The manufacturer will then put the inspected barrels in a place which is dry, sheltered and suitable for storage. Glue which is otherwise satisfactory, will be rejected if proper storage facilities are not provided for it.

17. If the official sample proves to be in compliance with the specification, the manufacturer will be notified that the lot of glue covered by the official sample has been certified. Certified hide glue is the only hide glue which aircraft manufacturers will be permitted to use. Hide glue which does not comply in every respect with this specification will not be certified, and its use will not be permitted on government aircraft contracts. If an inspected glue fails to be certified, the manufacturer will be required to remove the inspection labels.

18. The glue manufacturer must report to the Raw Materials Department, Bureau of Aircraft Production, and to the Senior Inspector, Forest Products Laboratory, Madison, Wis., every sale of certified hide glue. The reports must be in duplicate and they should include the amount of glue, the number of the label of every barrel shipped, the name and address of the consignee, and the date of shipment (or sale).

19. No glue which has been rejected shall be offered to any department of the Bureau of Aircraft Production or to any aircraft contractor to the government without a full statement of the cause of rejection.

SPECIFICATIONS
FOR HANDLING
HIDE GLUE.

1. This specification is drawn to cover the requirements of the Bureau of Aircraft Production for the handling and testing of hide glue at airplane and propeller factories.

2. All the animal glue used in the construction of propellers and for splices of airplane structural members shall be hide glue certified in accordance with Specification No. 14,000-B.

GLUE MUST
BE SOAKED
AT LEAST TWO
HOURS.

3. *Soaking*.—The glue and pure cold water must be weighed out separately, and according to the proportions recommended for the particular glue by the Senior Inspector, Bureau of Aircraft Production, Forest Products Laboratory. They should then be mixed, thoroughly stirred, and allowed to stand in a cold place in a covered vessel until the glue is thoroughly soaked and softened. The mixture must stand at least two hours.

4. *Melting*.—After the glue has been sufficiently soaked, the water-glue mixture shall be melted on a water bath or in a carefully regulated electric heater. The glue solution must never be permitted to rise to a temperature exceeding 150 deg. Fahr. About 140 deg. Fahr. provides an excellent working temperature.

NO GLUE
HEATED LONGER
THAN 8 HOURS
CAN BE USED.

5. *Heating*.—Glue shall not be heated for a greater length of time than is absolutely necessary. Glue which has been heated for 8 hours or longer must not be used. All the glue which has been heated at any time on any day shall be rejected at the close of that day and must not be used on any succeeding day. In order to prevent the loss of moisture, the glue pot shall be kept covered when not in actual and continuous use. Any skin or scum which forms on the surface of the glue shall be removed.

6. *Application*.—The glue shall be applied to the wood in a room which is free from draughts and as

warm and humid as healthful working conditions allow.

7. *Wood.*—The wood shall be uniformly dry and at least as warm as the air in the glue room. High temperatures and prolonged heating of the wood should be avoided in order to prevent distorting the surface. The wood surfaces shall “fit” perfectly and they shall be clean.

8. *Spreading.*—The glue shall be applied to both surfaces of the joint, and shall be spread freely and as rapidly as is consistent with good workmanship.

APPLY GLUE
TO BOTH
SURFACES.

9. *Pressing.*—The clamp pressure or other pressure shall be applied quickly in order to prevent the glue from jellying or setting. A sufficient number of clamps should be used to insure that the wood is in close contact at all points, and that the pressure is evenly distributed.

10. *Sanitation.*—Only enough glue shall be mixed at any one time for one day’s work. The glue pots, brushes, etc., shall be cleaned out each night with boiling water and all the glue left over after the day’s work shall be discarded. The brushes will remain sweet if left over night in a solution of carbolic acid.

11. A glue test specimen shall be made of 1-inch boards of sufficient size to furnish ten test specimens conforming to dimensions specified in Fig. 5, page 49. The boards shall be representative of the wood on which the glue is to be used. The specimen shall be made up under the average conditions prevailing in the glue room. The gluing shall represent actual practice and no special precautions other than those ordinarily taken shall be employed in preparing the glue or wood. The gluing shall be performed by the employes of the airplane factory accustomed to this kind of work. No protective coating of any kind shall be applied to the wood surfaces or to the finished specimen. The specimen shall be held in the clamps for 15 to 24 hours. After being removed from the clamps it shall stand for 6 additional days in a warm, dry place. The specimens shall be cut into ten shear blocks which conform to the dimensions shown in Fig. 5, page 49.

TEST
SPECIMEN.

PERIODIC
STRENGTH
TESTS MUST
BE MADE.

TESTS.

12. The following test shall be made to determine the strength of the glued joint. Ten of the shear blocks shall be tested in a shearing machine immediately after sawing, and the strength of the glue in shear shall not be less than that of the wood.

13. The required strength must be obtained from 80 per cent. of the specimens tested.

14. Test blocks may be sent to the Senior Inspector, Bureau of Aircraft Production, Forest Products Laboratory, Madison, Wisconsin, for this test. When blocks are forwarded for this test, they should be plainly and clearly marked and should be accompanied by Bureau of Aircraft Production I. R. Form No. 68 (Request for Glue Tests).

INSPECTION.

15. The inspector of the Bureau of Aircraft Production shall have free access to all parts of the plant of the manufacturer where this work is being carried on, and shall be afforded every reasonable facility to satisfy himself that the work is in accordance with this specification. Tests shall be made under the supervision of a representative of the Bureau of Aircraft Production.

CHAPTER XI.

RESULTS OF TESTS ON MISCELLANEOUS GLUES.

TESTS in accordance with the methods outlined in the foregoing specifications on about 30 samples of animal glues obtained through miscellaneous sources were made. The results of these tests are of considerable interest, both as a guide to the operator and to the prospective purchaser of glues. The results are given in Tables 1 to 9. Some of these samples were sent by Laboratory *F* to two glue manufacturers, termed Lab. *A* and Lab. *N*, where the tests were made by their own methods. The comparisons obtained are very interesting.

THE RESULTS
OF TESTS
FROM THREE
LABORATORIES.

Table 1 gives a description of the samples tested.

The results of the viscosity tests are given in Table 2. Since a different type of viscosimeter, and probably a different volume of glue solution was used by each of the three laboratories, the results cannot be directly compared. This emphasizes the need for a standard apparatus and method of determining viscosities.

VISCOSITY
TESTS.

In Table 3 the glues are arranged in order of their relative jelly strength. This arrangement shows a general agreement between the three laboratories as to which are the strong glues and which the weak.

JELLY
STRENGTH.

From the results of the various comparative tests described above, it might be presumed that these tests are of little value, and might as well be discarded. This is not the case, however, for while it is true that the results from different laboratories cannot be directly compared, because the methods of test are different and because of the personal equations, at any one laboratory the value of a glue can be pretty closely approximated by the use of these tests, because they are made in the same way each time. The results above quoted, however, show, very emphatically, the need for a standard system of testing to be followed by all glue laboratories.

THE RESULTS
CANNOT BE
COMPARED
DIRECTLY.

REACTION.

The reaction of the various glues to litmus is shown in Table 4. It seems strange that there should be such a disagreement among the three laboratories as to whether the glues were acid, alkaline or neutral. In most cases, of course, the reaction was very slight in either direction, and the difference must be due either

TABLE 1.—DATA ON GLUE SAMPLES.

Sample No.	Kind (Information from manufacturer.)	Price* quoted per lb.	Remarks.
1.....	Animal.		Recommended by the manufacturer for hardwood.
2.....	Animal.		Recommended for softwoods.
3.....	Blend of fish and animal.	46c	A special fish blend joint glue.
4.....	Animal.	60c	
5.....	First run pure hide glue.	51c	
7.....	Vegetable glue.		Prepared paste.
8.....			Probably a casein product.
9.....	Very high-grade glue.		
10.....	Hide glue.		
11.....	Hide glue.		
12.....	Hide glue.		
13.....			From lab. stock. Probably foreign glue.
14.....			
15.....	Thin cut clear flake glue.	60c	
16.....	Extra clear flake glue.	45c	
17.....	Medium cut clear flake glue.	50c	
18.....	Highest testing.		
19.....		65c	
20.....	Pure rabbit skin glue.		
21.....	Exceptional water taking qualities.	55c Less Freight	
22.....			
23.....			
24.....			
25.....			
26.....			Contains a large amount of mineral matter.
27.....	Pure hide glue.	50c	
28.....	High-test glue.		

*June, 1917.

to the difference in judgment of the men who made the tests, or to a difference in litmus paper.

Laboratories A and N did not report upon this test. From Table 5 it is apparent that practically all the glues would have passed a test requiring that they stand 48 hours without showing signs of deterioration.

Table 6 shows typical results selected at random from glues tested by W. L. Jones, B. A. P. inspector stationed at the Forest Products Laboratory, the methods being those described in the appendix. The table is arranged in order of increasing viscosities, and is given here as it may be useful to the operator attempting to use the proposed methods.

TABLE 2—RESULTS OF VISCOSITY TESTS.

Glue No.	Viscosity			Ratio to Viscosity of Water		
	Lab. F Seconds	Lab. A Seconds	Lab. N Seconds	Lab. F*	Lab. A†	Lab. N‡
1.....	173.9	52.0	23.00	3.30	1.24	1.53
2.....	141.6	50.0	21.00	2.69	1.19	1.40
3.....	148.4	51.0	20.75	2.82	1.21	1.38
4.....	139.2	50.0	20.75	2.65	1.19	1.38
5.....	219.7	53.0	20.5	4.18	1.26	1.37
9.....	288.5	58.8	25.00	5.48	1.40	1.67
10.....	160.0	50.6	22.5	3.04	1.20	1.50
11.....	231.0	55.5	24.25	4.39	1.32	1.62
12.....	197.5	54.0	23.00	3.76	1.29	1.53
13.....	85.0	44.0	18.25	1.62	1.05	1.22
14.....	163.8	52.0	24.00	3.11	1.24	1.60
15.....	247.2	55.5	25.00	4.70	1.32	1.67
16.....	180.3	54.0	23.00	3.43	1.29	1.53
17.....	212.0	55.0	24.00	4.03	1.31	1.60
18.....	51.0	21.5	1.21	1.43
19.....	261.8	27.5	4.98	1.83
20.....	134.8	51.5	22.00	2.56	1.23	1.47
21.....	217.6	56.5	26.25	4.14	1.34	1.75
22.....	143.6	50.5	22.25	2.73	1.20	1.48
23.....	123.4	48.0	20.75	2.34	1.14	1.38
24.....	134.8	49.6	21.25	2.56	1.18	1.42
25.....	190.1	53.4	25.00	3.62	1.27	1.67
26.....	73.5	42.0	15.75	1.40	1.00	1.05
27.....	52.0	23.25	1.24	1.55
28.....	257.7	58.6	27.00	4.90	1.39	1.80

*Compared with the viscosity of water at 20° C., which is 52.6 seconds in this instrument. (Engler.)

†Compared with the viscosity of water at 60° C., which is about 42 seconds in this instrument.

‡Compared with the viscosity of water at 20° C., which is 15 seconds in this instrument.

TABLE 3—RESULTS OF JELL TESTS

No.	Lab. A*	Lab. N*	Lab. F†
1.....	69	140	..
2.....	64	120	4
3.....	61	90	5
4.....	65	110	4
5.....	67	66	3
9.....	73	166	1
10.....	67	136	3
11.....	71	152	1
12.....	67	142	3
13.....	Too low	50	6
14.....	66	86	4
15.....	72	164	2
16.....	66	132	3
17.....	70	146	2
18.....	68	148	2
19.....	70	144	2
20.....	70	142	3
21.....	69	134	2
22.....	64	118	4
23.....	70	136	2
24.....	62	76	4
25.....	66	138	4
26.....	Too low	40	7
27.....	70	154	3
28.....	72	156	1

NOTE—In Laboratory† tests, the glues were classified into groups according to their strength by finger test method as follows, group 1 being the strongest:

Group 1—Nos. 9, 11, 28.
 Group 2—Nos. 23, 15, 19, 18, 17, 21.
 Group 3—Nos. 15, 5, 12, 10, 1, 27, 20.
 Group 4—Nos. 14, 2, 25, 24, 4, 22.
 Group 5—No. 3.
 Group 6—No. 13.
 Group 7—No. 26.

*These values represent numerical figures obtained with the instruments in use at these laboratories.

†By finger test method.

TABLE 4—REACTION TO LITMUS.

No.	Lab. F	Lab. A	Lab. N
1.....	Slight acid	Alkaline	Very slight acid
2.....	Slight acid	Alkaline	Very slight acid
3.....	Very slight acid	Alkaline	Very slight acid
4.....	Slight acid	Alkaline	Neutral
5.....	Very slight acid	Alkaline	Very slight acid
9.....	Slight acid	Acid	Very slight acid
10.....	Slight acid	Alkaline	Very slight acid
11.....	Acid	Acid	Very slight acid
12.....	Neutral	Alkaline	Neutral
13.....	Slight acid	Acid	Fairly much acid
14.....	Neutral	Alkaline	Neutral
15.....	Neutral	Alkaline	Neutral
16.....	Neutral	Alkaline	Neutral
17.....	Neutral	Alkaline	Neutral
18.....		Alkaline	Very slight acid
19.....	Neutral		Neutral
20.....	Acid	Acid	Fairly much acid
21.....	Neutral	Alkaline	Neutral
22.....	Neutral	Alkaline	Very slight acid
23.....	Acid	Acid	Slight acid
24.....	Neutral	Alkaline	Neutral
25.....	Neutral	Alkaline	Neutral
26.....	Neutral	Alkaline	Neutral
27.....		Acid	Slight acid
28.....	Neutral	Alkaline	Neutral

A very interesting series of results is published by Linder & Frost (Proc. Am. Soc. Test. Mat., 1914, Part II, page 509). Data given on moisture, viscosity, cost, and breaking strength of 25 samples of glue.

TABLE 5—KEEPING QUALITIES

No.	Lab. F Hours**	No.	Lab. F. Hours**
1.....	142	17	334
2.....	52	18	142
3.....	142	19	*
4.....	142	20	97
5.....	142	21	*
9.....	142	22	142
10.....	142	23	142
11.....	52	24	*
12.....	218	25	218
13.....	142	26	97
14.....	97	27	142
15.....	*	28	*
16.....	218

*All samples discarded at the end of 334 hours. Samples marked with a star were not foul at this time.

**Time required for glue to develop an offensive odor.

TABLE 6.

Typical results obtained by methods recommended in appendix.

Glue, Sample No.	Viscosity, sec- onds (Engler)	Jelly strength (Standard 100 per cent.)	Melting Point 5-1 Jelly O. C.	Average Shear lbs. per Sq. In.	Per cent Wood Failure.	Average Dilu- tion water to Glue.
158	83.1	93%	24.1	2726	50	2¼-1
155	89.3	96%	24.3	2644	84	2½-1
239	89.9	78%	27.0	2370	42	2½-1
157	102.4	97%	27.5	2660	100	2½-1
299	102.8	100%	27.2
*	109.7	74%	27.5
**	118.8	83%	27.8
***	145.0	100%	28.5	3000
218	148.	101%	2866	86	2 -1
160	162.2	100%	23.8	3010	78	2¾-1
175	177.0	100%	30.6	2880	56	2½-1
166	180.6	105%	29.5	3150	88	2 -1
273	183.7	107%	2910	75	2¼-1
272	201.8	106%	29.0
153	213.3	104%	30.8	2890	26	2¼-1
174	259.5	120%	32.4	2793	69	2¼-1

*Peter Cooper Co.'s standard, 1%. **Peter Cooper Co.'s standard, 1¼. ***Bureau Aircraft Production standard sample.



CHAPTER XII.

GRADING THE GLUE SAMPLE.

AS explained before, the kinds of glue that may be obtained are almost infinite in variety. Indeed, there is an almost unlimited variation in the appearance of glue samples. Jerome Alexander (Jour. Soc. Chem. Ind., 1906, 25, 158) states: "In glue, above all things, appearances are deceptive. Even after a manufacturer has finished his glue he is obliged to test it in order to establish the grade of his finished product." Alexander grades his samples by standards which he keeps in his laboratory. He states (see above): "The choice of standards is a very important matter, for once they are taken all unknown glues are measured by them. Few published results of glue tests can be used for comparison, for seldom if ever have any two investigators worked on the same glue or glues, which have been described sometimes by their cost, sometimes by the stock from which they were manufactured, and upon which only partial determinations were made. That definite standards will simplify and harmonize the grading of glue is self evident.

GRADES OF GLUE
SUGGESTED BY
JEROME
ALEXANDER.

"We arbitrarily fix sixteen nearly equidistant grades, and assign to them values running from 10 to 160, allowing ten points between each grade.

160	80— $1\frac{3}{8}$
150	70— $\frac{1}{2}$
140	60— $1\frac{5}{8}$
130—A Extra	50— $1\frac{3}{4}$
120—1 Extra	40— $1\frac{7}{8}$
110—1	30—2
100—1 X	20
90— $1\frac{1}{4}$ X	10

"Opposite these grades I have set the grades established long ago by Peter Cooper, which are used for comparison by many American manufacturers and dealers."

PETER COOPER
GRADES.

RELATION
BETWEEN
VISCOSITY AND
JELLY
STRENGTH.

The following determinations were made to establish such definite figures on our standards as will enable anyone to pick out glues of the same characteristics. The higher standards, from 60 up, are neutral hide glues, clear, clean, well made, free from any odor of decomposition, and practically free from foam and grease, for the lower standards, bone glues were chosen, because most low test glues show abnormal viscosities. (The viscosities were taken in the apparatus described in Chapter VI, page 31. See original article Jerome Alexander Jour. Soc. Chem. Ind., 1906, 25, 158, for method. The jelly strength was taken as described in Chapter VII, page 37).

Standard	Viscosity (in secs.) at 80° C. Solution 25-100	Allowable Variation of Viscosity (in seconds) (either + or -)	Jelly Strength (in oz.) at 10° C.	Jelly Strength (in grams) at 10° C.
10	15 ½	¼
20	16	¼
30	16 ½	¼
40	17	¼	60	1701
50	18	½	82	2324
60	19	½	104	2948
70	20	½	126	3572
80	21	½	148	4196
90	22	¾	170	4820
100	23	¾	192	5443
110	24	¾	214	6067
120	25	1	236	6691
130	26	3	258	7314
140	28	5
150	34	8
160	40	12

Fernbach states, relative to the grading of glues (Glues and Gelatines, 1907, page 57): "A study of viscosities * * * of glues confirms what has already been said about the inadequacy of viscosity as the ultimate measure of glue strength. The author has tested more than thirty thousand samples of glue and gelatine, and relying invariably on the finger test (jelly strength) in preference to using any test machine. The results have always been concordant."

In general, the operator in grading a sample must rely mainly upon the jelly strength, using other tests as auxiliary aids, and for comparison, must have in his possession samples of known grades with which to compare his unknown test sample. He will find in general that the jelly strengths and viscosities are comparable, or in other words, he might grade on the basis of either. If they do not check he should look upon the sample with much suspicion and inquire carefully into the method of manufacture, quality of stock used, etc., before accepting the glue. In normal run glues, jelly strength and viscosity are the only tests absolutely needed.

HOW TO GRADE
THE SAMPLE.

See also Frost and Linder (Proc. Am. Soc. Test. Mat., 1914, page 509).



CHAPTER XIII.

SOME INTERESTING STRENGTH DATA ON GLUES.

TESTS on joint strengths obtained with hide glue on a number of species showed that it was possible to glue them without obtaining glue failures in the test. The species tested, all of which gave successful results, were the following:

Hard maple	Douglas fir	African mahogany	THESE WOODS GIVE STRONG GLUE JOINTS.
Yellow birch	Red oak	White mahogany	
Black walnut	White oak	Tanguile	
Red gum	Central American	Black cherry	
Yellow poplar	mahogany		

Similar tests on greenheart were unsuccessful. Numerous attempts made to glue this wood failed in producing a strong joint. Similar tests made on maple coated with varnish, shellac, and airplane dope also failed to give good joints. The conclusion was that it was dangerous practice to try to glue over wood coated with these materials. It is, of course, possible that special methods could be devised for doing such work if it was desirable. Similar tests using wood coated with lard oil, cylinder oil (mineral) and corn oil were made. The oils were rubbed into the wood with a cloth and the wood allowed to stand 15 hours before gluing. While no definite conclusion could be drawn, the results were surprisingly good. Specimens coated with all of these oils gave quite high strength values.

Tests on plywood glued with animal glue and soaked in gasoline and in engine oil indicated that these oils did not have a deleterious effect on the glue joint over a period of 15 days. Subsequent tests over a period of 4 months showed some weakening effect.

EFFECT OF
GASOLINE ON
STRENGTH OF
JOINTS.

The common assertion that scratched surfaces make stronger glued joints than smooth surfaces seems hard to prove. Comparative tests made on several occasions by the Forest Products Laboratory all indicate that the strengths of these two types of joints are practically the same.

SCRATCH
JOINTS VERSUS
SMOOTH.

TOOTH PLANED
JOINTS ARE
NOT ADVISED.

The test specimens used by the laboratory were pairs of hard maple blocks, some with smooth and some with tooth-planed contact surfaces. These blocks were glued with a high grade hide glue, allowed to stand for a week, and then sheared apart in an Olson universal testing machine. Four joints of each type were compared in a single test.

Eleven such tests gave the following average results:

COMPARATIVE STRENGTH OF SCRATCHED AND SMOOTH JOINTS

Test No.	Scratched Joints		Smooth Joints	
	Shear Strength Lbs. sq. in.	Wood Surface in Failure Per cent.	Shear Strength Lbs. sq. in.	Wood Surface in Failure Per cent.
1.....	1787	25	1855
2.....	1366	943
3.....	1976	3086	50
4.....	2409	75	1571	25
5.....	2298	100	2416	100
6.....	1947	75	1678	62
7.....	2310	12	1800
8.....	1835	100	2455	100
9.....	1425	2180	25
10.....	2330	2395	62
11.....	2180	2520	75
Gen. Av'g	1988	35	2040	47

It will be noted that in seven of the eleven tests smooth surfaces gave the better adhesion. Consequently it would seem that there is no advantage in tooth-planing wood for gluing purposes.

Some interesting points have been brought out on the gluing of laminated construction, particularly airplane propellers, from recent experiments made at the Forest Products Laboratory at Madison, Wisconsin.

HEATING WOOD
BEFORE GLUING
GIVES STRONGER
JOINTS BUT
RETARDS
SETTING OF
THE GLUE.

Propellers had been found to give trouble with open joints when made of certain kinds of wood, and glued with certified hide glue. Propellers of oak and birch very frequently had open joints, while mahogany propellers could be satisfactorily glued even without heating the laminations. Heating the oak and birch laminations before gluing was found to give firm glue joints, and even in mahogany as well it was found that

if the laminations were heated before gluing, the joints were more uniform in strength. All propellers in which the laminations were heated before gluing gave firm joints which showed no tendency to open up.

Heating the laminations before gluing, however, was found to seriously retard the setting of the glue. Strength tests were made on large sized blocks glued up with hide glue to determine what effect heating laminations had on the glue strength. The tests were made about 10 days after gluing. The results obtained on this test are shown in the following table:

SHEARING STRENGTHS DEVELOPED IN LARGE GLUED UP BLOCKS WHEN UNDER PRESSURE FOR 8, 10 AND 12 HOURS.*

Central American Mahogany.

	8 hrs. under Press.			10 hrs. under Press.			12 hrs. under Press.		
	Max.	Min.	Av.	Max.	Min.	Av.	Max.	Min.	Av.
Cold	2489	1251	1949	2418	1446	1995	2098	1280	1645
Hot	1735	1250	1567	1845	1160	1589	1788	1390	1635

Northern Red Oak

	8 hrs. under Press.			10 hrs. under Press.			12 hrs. under Press.		
	Max.	Min.	Av.	Max.	Min.	Av.	Max.	Min.	Av.
Cold	2489	1251	1949	2418	1446	1995	2096	1280	1646
Hot	2001	1250	1659	2150	1362	1739	2220	1542	1910

Hard Maple

	8 hrs. under Press.			10 hrs. under Press.			12 hrs. under Press.		
	Max.	Min.	Av.	Max.	Min.	Av.	Max.	Min.	Av.
Cold	3620	2367	3015	3170	1900	2751	3072	1815	2361
Hot	3260	778	1652	3338	2124	2584	2960	2015	2576

*Strength tests made 10 days after gluing.

While in all species the strength of the hide glue was fully developed in eight hours in cold blocks, in hot blocks the full glue strength was not developed in 10 hours, and in oak even in 12 hours, an increase in strength being clearly shown for an increase in time under pressure.

High density woods have been found to absorb heat faster and in greater quantities than low density woods, so that mahogany showed less retarding effect on the glue than the oak and maple.

Heating laminations has been shown to be desirable in order that open joints may be avoided, while at the same time the strength distribution becomes more uniform. The retarded setting of the hide glue requires

a longer pressure period to develop full strength, and under the conditions prevalent in glue rooms, a period of 12 hours under pressure is not long enough to develop the full strength of the glue.

HIGH GRADE
GLUES ARE
MORE
MOISTURE
RESISTANT
THAN LOW
GRADE ONES.

That there is a close relation between the viscosity and therefore the grade of animal glues, and their resistance to loss of strength in moist air, is strongly indicated in the following table, which gives the length of time different glues resisted a humidity of 98 per cent.

Glue No.	TEST 1			TEST 2		TEST 3		
	Relative Viscosity (Engler)	Jelly Strength by Smith Tester	No. of Specimens Used.	Ave. Time Before Failure—Hours	No. of Specimens Used	Ave. Time Before Failure—Hours.	No. of Specimens Used	*Av. Time Before Failure After Raising Humidity to 98%
13.....	1.62	222	2	10½	4	12	4	24
†7.....	2	4	12	4	24
36.....	1.70	219	2	12 1/7	4	14½	4	24
34.....	2.00	267	2	17	4	26½	4	48
37.....	1.92	256	2	13	4	44
35.....	2.90	315	2	42	4	36
19.....	4.98	356	4	59½
21.....	4.14	338	4	48	4	66
9.....	5.48	416	4	66½	4	198

*In this test the specimens were kept at 90 per cent humidity for 120 hours (5 days).

†This is a vegetable glue.

Specimens of 1/8-inch birch veneer were glued two-ply with the grain parallel, and with one square inch of glued surface. The specimens were suspended in a humidity chamber with a 1-pound weight hung on each, and the time required for failure of the glue joint was noted. Tests one and two were made at 98 per cent. humidity. In test three the specimens were kept at 90 per cent. humidity for 120 hours, when the humidity was raised to 98 per cent. No failure occurred at 90 per cent. The temperature was about 80 deg. Fahr.

CHAPTER XIV.

USE AND APPLICATION OF THE GLUE HYDROMETER.

A GLUE hydrometer is an instrument for measuring the density of glue solutions and expressing the results in terms of the density of water, or in some scale such as Baume degrees that in effect also express results in terms of the density of water. Since the density of both glue solutions and water vary with temperature, hydrometer readings must take accurate account of temperature.

THE GLUE
HYDROMETER.

The glue hydrometer usually employed consists of a copper pot and a hydrometer arranged for temperature of 75° C., or 167° F. The melted glue is poured into the copper receptacle and the hydrometer is allowed to sink until it finds its position. Some experts employ what is known as Weinhagen's Hydrometer. This is provided with a thermometric correction scale at the top of the instrument, and this is always clear of the liquid when the hydrometer is immersed. The temperature must be adjusted accurately before making the determination.

This instrument is used to determine water absorption. It is also used when inspecting glue rooms, determining the amount of water and glue used by immersing the instrument into the glue solution in the tanks, cookers or glue pots. This also affords a very good check on the loss due to evaporation. This instrument cannot be used to determine glue quality, as its readings have no bearing whatever on viscosity or adhesiveness.

THE
HYDROMETER
DOES NOT SHOW
THE QUALITY
OF THE GLUE.



APPENDIX TO BOOK I

MODERN GLUES AND GLUE TESTING

METHODS OF TESTING
ANIMAL GLUE

IN USE AT THE

FOREST PRODUCTS LABORATORY
MADISON, WISCONSIN



APPENDIX.

METHODS OF TESTING ANIMAL GLUE IN USE AT THE FOREST PRODUCTS LABORATORY.*

DURING the war all the glue for use in aircraft construction was tested by the Bureau of Aircraft Production inspectors at the Forest Products Laboratory, Madison, Wis. More than a million pounds of hide glue furnished by ten different manufacturers had to be examined before its shipment to the various aircraft factories was permitted. This is not the first attempt which has been made to introduce standards in the glue trade, but it is the first instance in which the majority of the large manufacturers, as well as many of the purchasers of glue, have recognized the same standards and assented to the validity of the same methods of testing.

OVER ONE
MILLION
POUNDS OF
GLUE INSPECTED
BY THESE
METHODS.

The methods which were adopted were selected as being those of rational basis, direct practical bearing, simplicity and convenience. They are not ideal; a few of them are scarcely satisfactory. Nevertheless, when properly applied and interpreted, they will enable the chemist to select and grade glue.

The physical constants of glues and glue solutions cannot be measured with the same precision as those of most of the materials which the chemist is called upon to test. Glue is a substance of widely varying chemical composition and physical condition. Tests made upon it are profoundly affected by factors which are difficult to control. Time, temperature, colloidal condition and the effects of micro-organisms are unusually important in glue testing.

The methods which were adopted are as follows:

For accurate work the viscosity, jelly strength and jelly melting point determinations should be made upon a sample which has been carefully dried at a low temperature to constant weight. The precaution, however, is frequently disregarded.

*From paper prepared by Wilbur Lloyd Jones, senior inspector, B. A. P.

DETAILED
METHOD FOR
VISCOSITY.

Weigh out 50 grams of ground glue and add it to 250 c. c. of cold water. Allow the mixture to stand for two or three hours in an ice box and keep the breaker containing the mixture covered with a watch glass. Then place the breaker in the water bath and raise the temperature gradually to 60° C., stirring every once in a while. Keep the watch glass in place when the mixture is not being stirred in order that the moisture which escapes from the solution may be condensed. When the lumps have disappeared from the solution, recover the drops of condensed moisture on the watch glass and strain the solution through a piece of cheese cloth or wire gauze. Then cover once more with the watch glass and allow the solution to remain in the water bath until the temperature of the water in the annular ring of the viscosimeter is about 60° C. An Engler viscosimeter is used. Place a 200 c. c. viscosimeter flask underneath the orifice of the viscosimeter. Then pour the glue solution into the cup of the viscosimeter until it just covers each of the three level points, and adjust the thumb screws on the stand of the viscosimeter so that the instrument is perfectly level. This should be done as quickly as possible in order that loss of moisture from the solution will be at a minimum. Then place the cover on the viscosimeter, insert the thermometer and regulate the temperature so that the glue solution in the cup is exactly 60° C., and the water in the jacket is somewhere between 60° and 61° C. Then remove the wooden plug with one hand and snap the stop watch with the other, and allow the glue solution to flow until the meniscus is exactly opposite the 200 c. c. mark on the flask. Then snap the stop watch again and note the reading. The viscosity of the solution is the number of seconds required for 200 c. c. of solution to flow at 60° C. through the standard orifice of the viscosimeter. Before making a second determination, clean out the apparatus thoroughly and be sure that no glue remains in the orifice, nor on the wooden plug. The tests for odor, reaction, foam, jelly, melting point, and grease should be made on the residue left from the viscosity determination.

The odor is determined by smelling the liquid.

Take a piece of red and a piece of blue litmus and dip both into the glue solution. Remove them and examine for change of color. If the blue litmus turns red or reddish, the solution is acidic. If the red litmus turns blue, the solution is alkaline. Glue solutions are usually either slightly acidic or neutral.

THE REACTION.

The glue solution is then placed in a water bath and heated to 60° C. It is agitated by a stirrer attached to a small electric motor for exactly one minute, after which time it is allowed to stand for exactly one minute. The height of the foam is then measured.

FOAM.

The residue is then warmed up once more in the water bath and a small quantity of an aqueous solution of a dye is added to it. A brush is then carefully cleaned until it is free from every trace of grease. A test is made on the brush by dipping it into a small portion of a dye solution and painting a broad streak upon a clean sheet of unglazed white paper. If the colored streak is free from spots where the color has been repelled from the paper, the brush is sufficiently clean to proceed with the grease test. The brush is placed in the glue solution now colored with dye and several streaks are painted upon clean unglazed white paper, employing a moderate amount of glue solution in the brush each time. The number of "eyes" in the colored streaks indicates the amount of grease in the glue. (See pages 33 and 34.)

GREASE.

The instrument which is in use at the Forest Products Laboratory, Madison, Wisconsin, for determining the jelly strength of glues, is a modified form of an apparatus which is used for the same purpose in the laboratory of one of the large glue manufacturing companies.

JELLY
STRENGTH.

It is essentially a "float" which rests lightly on the surface of a jelly, and a "plunger," to which is attached a scale by means of which the depth of penetration, or rather, depression, can be measured.

A NEW METHOD
FOR JELLY
STRENGTH.

The "float" is made of brass plate. It should not weigh more than 200 grams. The bottom surface, which comes in contact with the jelly, should be rather large, in order to distribute the weight and to prevent

the float itself from depressing the jelly to any appreciable extent. At the top of the "float" there is a guide of rectangular cross section through which the standard or scale of the "plunger" moves freely. An inverted triangular section (1 c. m. in altitude) is cut away from the top of the front face of this guide, and the resulting diagonal line is divided into 10 equal parts in order to enable the operator to read the depression of the standard to tenths of a centimeter, and to estimate it to hundredths.

THE PLUNGER.

The nose of the "plunger" is hollow so that it can be filled with shot, and the weight of the plunger altered at will. The hole through which the shot are added or withdrawn is closed with a screw. The standard is graduated in centimeters, and the zero mark on the standard is located at that point which is opposite the zero mark on the graduations on the "float" when the nose of the "plunger" is resting on a perfectly level surface. These details are explained in Fig. 17.

This instrument, when used to test 12 to 1 jellies, has been found to be very delicate if the total weight of the "plunger" is 250 grams. To raise the weight of the "plunger" to this amount, a brass weight, a drawing of which will be found in the plan, will have to be placed on top of the nose.

In making jelly tests, this apparatus is used as follows:

Exactly 25 grams of ground glue are added to 300 c. c. of cold water. The mixture is stirred, covered with a watch glass and allowed to stand in an ice box for two or three hours. At the end of this time the mixture is placed in a water bath and heated gradually to 60° C., stirring frequently but keeping the beaker covered with the watch glass to prevent evaporation. When the solution is free from lumps, the condensed moisture is returned to the solution and the glue is poured into a crystallizing dish of standard size and shape. A dish which is 3½ inches in diameter and 2 inches deep will be found very convenient for this purpose. The depth of the layer of glue in the crystallizing dish should be exactly the same in every case. The crystallizing dish with its contents is then

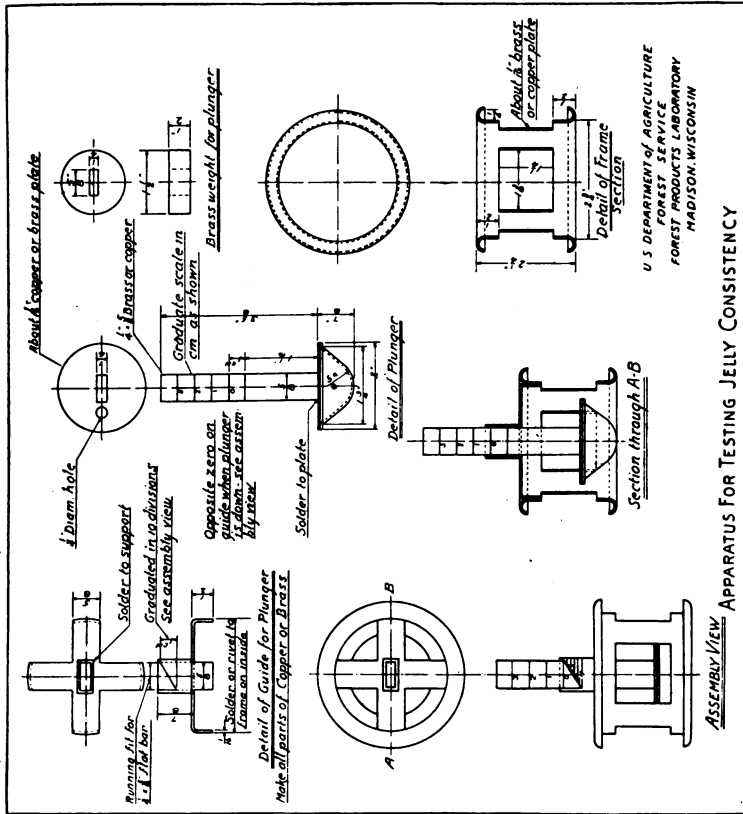

U.S. DEPARTMENT OF AGRICULTURE
 FOREST SERVICE
 FOREST PRODUCTS LABORATORY
 MADISON, WISCONSIN

APPARATUS FOR TESTING JELLY CONSISTENCY

FIG. 17

DETERMINING
JELLY
STRENGTH.

placed in an ice box at from 5° to 10° C., for 12 or 15 hours. At the end of this time it is removed and the jelly strength of the glue is determined immediately. This is done by comparison. A sample of standard glue should be treated in exactly the same way as described above and at exactly the same time as the glue which is being studied. The glue being tested and the standard should be removed from the ice box at the same time and the jelly strength first determined by pressure with the fingers. Then the brass jelly tester should be employed and 3 or 4 readings of the amount of penetration determined. Obviously the weaker the jelly the greater will be the depth to which the plunger will penetrate.

The depression of the 250-gram plunger against the resistance of the jelly is measured in millimeters, and compared with the corresponding depression of the plunger in the case of the standard glue. The consistency of the jelly is obviously inversely proportional to the depth of depression. This, of course, is true only in a more or less crude way; it is not an exact mathematical relationship.

This test will be found to be as delicate, if, indeed, not more so, than the so-called finger test. Jelly strength is expressed in percentages and it is equal to 100 times the amount of penetration in the standard glue divided by the amount of penetration in the glue being tested.

KEEPING
QUALITIES.

The jelly resulting from the above test is then allowed to stand uncovered in the laboratory at room temperature for 48 hours, at the end of which time the skin on the surface is broken and the odor of the jelly is noted. Even after 48 hours the odor should be sweet.

JELLY
MELTING POINT.

To determine the melting point of a jelly the following procedure is employed: A 12-inch length of 6-millimeter glass tubing is bent in the middle so as to form a U-tube.

A drop of hot glue solution (5 parts of water to 1 of glue) is introduced into one arm of the U-tube. A stirring rod or a medicine dropper can be used conveniently for this purpose. If a 12-to-1 jelly were

used a more sharply defined melting point might be obtained, but its behavior would be farther removed from the concentrated solutions which are used in gluing practice, and it would accordingly be of less significance. When the drop of glue has sunk to a certain mark which has been etched half way down one side of the tube, the opening of the other arm is closed with the fore-finger, and the tube quickly plunged in ice water. The glue will now be found to be stationary, a cylinder of jelly exactly opposite a fixed mark on the tube. It is important that there should be no glue in any other part of the tube, because it might clog the bore and subsequently prevent the free movement of the cylinder of glue.

DETAILS OF
MELTING
POINT TEST.

The U-tube with its cylinder of jelly is allowed to stand about an hour at 10° to 15° C. It is then immersed in a beaker of water (10° to 15° C.) to such a depth that the glue is beneath the level of the surface of the water. The temperature is then slowly raised and the water stirred constantly. The tube is fastened to a sensitive thermometer by means of rubber bands. At a certain definite temperature the cylinder of jelly will commence to slip from its position, sinking slowly at first. The temperature at which movement is first noticeable is taken as the melting point. The heat communicated from the walls of the tube melts the surface of the cylinder of jelly which is in contact with it, thereby allowing the jelly to fall of its own weight. Glue jelly is a very poor conductor of heat. Consequently, other methods which require the thermal penetration of a considerable mass of jelly will be handicapped on that account.

The adhesive or strength test is carried out as follows: A piece of hard maple is cut into two halves of the size and shape indicated by the first specimen in Fig. 6. Dense, hard, straight-grained, thoroughly seasoned wood, free from defects, should be used. Preferably it should be flat-sawed lumber. The two blocks should be put through the planer and then over the jointer. The surfaces which are to be placed in contact should be absolutely flat, and they should fit perfectly. The moisture content should be

ADHESIVENESS.

PREPARATION
OF BLOCKS
FOR STRENGTH
TESTS.

between 6 and 13 per cent. It has been found unnecessary to warm the test blocks above the temperature of the room. Moreover, it is undesirable, because even a moderate heating is liable to distort the blocks to a certain extent and prevent them from fitting together perfectly.

GLUE APPLIED
AT FOUR
DIRECTIONS.

It is a good plan to test every unknown glue at four different water-glue ratios. With a moderately high grade glue, such as Peter Cooper's Standard No. 1, sets of specimens should be prepared, using 2, $2\frac{1}{4}$, $2\frac{1}{2}$ and $2\frac{3}{4}$ parts of water respectively to one part of glue. It might be advisable in the case of an exceedingly high grade glue to prepare a test block at 3 to 1, and there are low grade glues which will give best results with less than 2 parts of water to 1 of glue.

PRESSURE
MUST BE
MODERATE.

The glue solution should be used as soon as possible after it has melted and attained a temperature of 140° to 150° F. The glue should be applied freely to both of the surfaces which are to be joined. It often helps considerably if the hot glue is brushed well into the wood, to assure proper penetration by the glue. The blocks should then be allowed to stand until the glue has thickened a little, but they should not stand long enough for the glue to "set." If the glue is touched from time to time by a finger which is rather quickly withdrawn, there will come a time when fibers or strings of glue an inch or two in length will be pulled up from the surface. When this point has been reached, the two blocks should be joined, rubbed together slightly with light pressure, and then placed in a press designed in such a way as to assure an evenly distributed pressure. As soon as possible the pressure should be applied. It should be a moderate pressure, just sufficient to bring the edges of the glued surfaces into approximate contact. It should be remembered that for testing purposes it is better to employ too little pressure than too much.

By working rapidly one can prepare joints at four different concentrations for any glue, stack them in the press so that they will all be subjected to the same pressure, and finish the adjustment before the joint which was glued first has been "set."

These joints should be left in the press for at least 15 hours. They may be then removed and placed in a drying rack, where they should remain for at least six additional days. At the end of that time they may be cut into shear blocks, as shown in Figs. 5 and 6.

These shear blocks are then tested in an Olsen Universal Testing Machine (Fig. 8), provided with a special shearing tool as shown in Fig. 7. The load should be applied at a rate not to exceed .025 inch per minute. A shearing strain is brought to bear on the layer of glue between the two wooden halves of the specimen. At a certain load each shear block will fail, and the failure will be either in the glue, in the wood, or in both. The load at which failure took place and the exact area of fracture are measured. The shearing stress in pounds per square inch can then be calculated.

It is obvious that, whenever the failure occurred in the wood exclusively, the glue would have resisted a force somewhat greater than the one applied. It is only when the failure is in the glue entirely that its shearing strength has been fairly determined. It is more than probable that the higher the percentage the amount of failure in the wood assumes, the greater will be the disparity between the actual strength of the glue and the load at which failure took place. A specimen which failed at 2,000 pounds per square inch, 90 per cent. of the fracture being in the wood, might indicate a stronger glue than one failed at 2,500 pounds per square inch where only 10 per cent. of the fracture was in the wood.

PER CENT
OF WOOD
FAILURE HAS
SIGNIFICANCE.

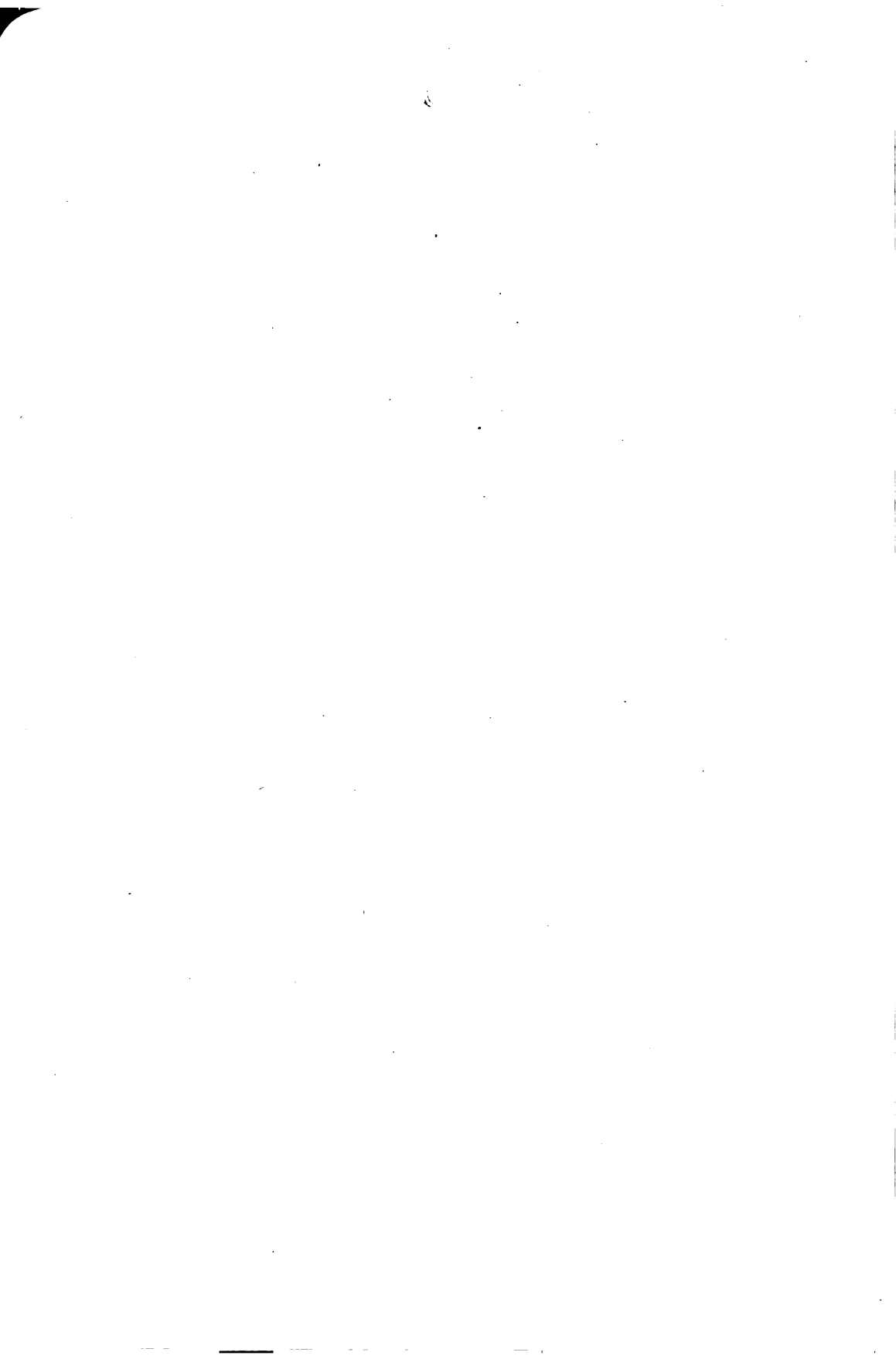

Book II

GLUE ROOM EQUIP-
MENT AND THE USE
OF GLUE

BY
C. MORTIMER BEZEAU





Book II

TABLE OF CONTENTS

CHAPTER XV— <i>Preparing the Wood for the Glue</i>	
The Lumber—Storage—Test for Dryness—Warming the Lumber—Ideal Gluing Temperature.....	105
CHAPTER XVI— <i>Preparation of Core Stock</i>	
The Core Stock Free from Checks—Crossbanding— Allowing the Crossbanded Core to Dry—Right and Wrong Sides—Conditions Affecting Thickness.....	109
CHAPTER XVII— <i>Preparing Glue for Use</i>	
The Glue Mixer—Soaking Glue—Regarding “Cook- ing”—The Glue Heater—The Cleaning Vat—Use of Pure Water—Rainwater—Soda in Water—Use of a Glue Size—Regarding the Changing of Brands.....	115
CHAPTER XVIII— <i>Ideal Surface for Gluing</i>	
Hardwoods — End Grain — Edge Gluing — Concave Edges	123
CHAPTER XIX— <i>Covering Capacity of Glue</i>	
High Grade Glue—Spread Costs—Wastage—Efficiency	127
CHAPTER XX— <i>Glue Room Equipment</i>	
Modern Appliances—Kinds of Cauls—To Prevent Glue from Sticking to Cauls.....	131
CHAPTER XXI— <i>An Ideal Glue Room</i>	
Ground Floor Location—The Heaters—Ventilation— Drying Room—Circulation of Air.....	135
CHAPTER XXII— <i>Evolution of Glue Room Practice</i>	
History—Progress—Unsolved Problems—Conditions in Europe	141

CHAPTER XXIII—*Glue and Finishing Departments*

Shifting of Responsibility—Blisters—Effect of Water on Veneers—Loose Veneer—An Example of Trouble—Playing the Game Square.....	145
--	-----

CHAPTER XXIV—*Veneering Scroll Work*

Regarding Designs—Elimination of Difficulties—A Lesson for Beginners—Thickness of Veneer.....	149
---	-----

CHAPTER XXV—*Laying Fine Face Veneers*

Importance of Good Veneer—The Redryer—The Hot Box—Taping Veneer—Spreading the Glue—Open Joints—Use of Warm Cauls.....	153
---	-----

CHAPTER XXVI—*Spreading the Glue*

Evenness is Essential—Intelligence—Regarding Foam—Good Glue is Necessary.....	161
---	-----

CHAPTER XXVII—*The Glue Salesman*

The Science of Salesmanship—Know Your Line and Don't Knock the Other Fellow's—Friendship—Sales-Tests—Enthusiasm—Order Takers—Competitors—Service—Kinds of Salesmen—Advertising—Form Letters and Trade Papers.....	165
---	-----

CHAPTER XXVIII—*Buying and Selling Glue*

Purchasing Department—Quality vs. Price—Requisitions—Recording Tests.....	175
---	-----

CHAPTER XXIX—*Paper Box Adhesives*

Selection of Glue—Box Making Machines—Silicate of Soda.....	179
---	-----

CHAPTER XXX—*Avoid Abuses*

Good Glue—Glue Room Temperature—Weighing—Boiling of Water—Correct Temperature—Melting—Freezing—Co-operation.....	181
--	-----

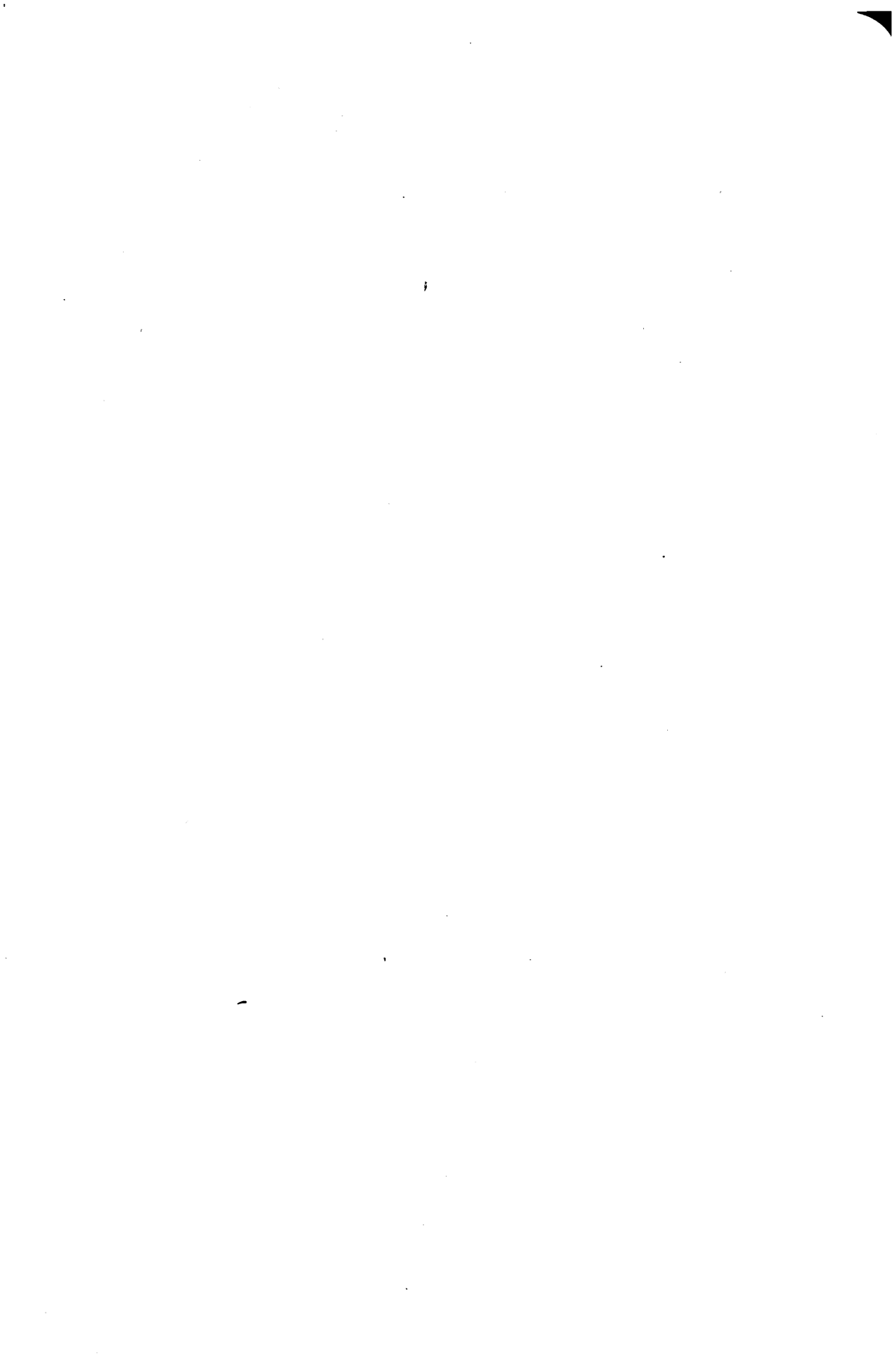



CHAPTER XV.

PREPARING THE WOOD FOR THE GLUE.

TO obtain the best results in the glue room it is not enough that the glue be properly prepared for the wood; it is equally necessary to have the wood properly prepared for the glue. This preparation should commence early in the process of making lumber—as far back as the time when the tree is cut down in the forest. Trees should preferably be cut during the late fall and winter months, for at this time the trees are dormant and fairly free from sap. If the tree is cut down during the spring or summer months when it is in the growing stage the wood is very susceptible to atmospheric changes; and the continual expanding and contracting of the wood is very detrimental to the life of a glue joint. Much of this difficulty may be overcome by allowing the lumber to dry or season for several years. However, long air seasoning is no longer feasible, and kiln drying is usually resorted to.

THE LUMBER
SHOULD BE
PREPARED

Every factory should have a place for storing lumber between the dry-kiln and the workshop. This storehouse should be well ventilated so that the air will be occasionally changed—fresh air entering from the outside; which will give it the right humidity. The lumber should be made quite dry in the dry-kiln before being placed in this storehouse, which should be kept at a temperature of about 60 degrees Fahrenheit, which temperature, together with the humidity in a properly ventilated place, will enable the lumber to so adjust itself that it will become less changeable in its nature and less prone to yield to atmospheric influences, and, therefore, more dependable after it is worked up.

STORED AFTER
LEAVING
KILN

In order to save extra handling of the lumber, tracks should be laid in the storehouse so that it may receive the loaded cars direct from the dry-kiln; and then in turn send them to the cutting-out department

without any changes. If this cannot be done the lumber must be piled with strips between each layer the same as when piling for the dry-kiln.

TEST LUMBER
FOR
DRYNESS

Lumber should always be tested for dryness before being glued up. If unfit stock be worked up it will never be made right and will always be a source of trouble.

A method of testing lumber for moisture by no means uncommon is by carefully measuring the width, then heating it in an oven or hot-box and noting the amount of shrinkage. But this is not a safe test. The better method is to weigh a small piece on a very sensitive scale; and after heating in an oven at about 215° F., for twenty-four hours, note the change in weight. Before weighing the second time the board should be allowed to cool to the same temperature as when it was first weighed. Heating in the oven should eliminate the last particle of moisture and the difference in weight before and after heating should give the percentage of moisture which the lumber contains.

WARM THE
LUMBER IF
COLD

Lumber should never be glued up when cold, whether it be edge jointing or veneering; and whether it be animal or vegetable glue that is to be used, it will be safer to warm the wood if it is cold. This is due to the fact that the cold glue solution, or one that is chilled by cold wood, is too viscous to permit the glue to enter the pores and obtain a hold. However, care must be taken not to overdo the heating. The best results are obtained between 80° F. and 95° F.

All things must work in harmony in order to produce the best results, and the temperature of the room in which the work is done must be in harmony with the required temperature of the wood, as well as the temperature of the glue. There was a time when a great many people had the idea that the higher the temperature of the glue-room the better; with the result that the temperature was such as to be detrimental to the health of the workmen. All this was in harmony with the other mistaken idea that glue itself had to be prepared and used at a high temperature. But careful experiments show that a temperature suit-

able for the workmen is suitable for the work. Such a temperature is from 70 degrees to 75 degrees Fahrenheit. While this temperature is sufficiently high, under no circumstances should the glue be used at a lower temperature. It is not enough to have the glue hot and wood warm, because the cold air will chill the outer surface of the spread and impair its power of adhesion.

AN AVERAGE
TEMPERATURE

The temperature here indicated is the one to be maintained at the point of contact between the air and the glue. For this reason the thermometer should be on a level with the glue spreader and veneer-laying bench. A few feet in height frequently makes a difference of several degrees in the temperature of the air, especially during the period of early morning heating before the warm air has been diffused uniformly through the whole room. For this reason, if the thermometer is placed higher than the point of contact between the air and the glue, one is liable to begin operations in a temperature several degrees lower than that required, thereby injuring the work without knowing it.

With the temperature of the air at 75 degrees Fahrenheit, the wood at 95 degrees and the glue at 140 degrees, we have that ideal combination which, everything else being equal, will insure the best possible results.

IDEAL
GLUING
COMBINATION

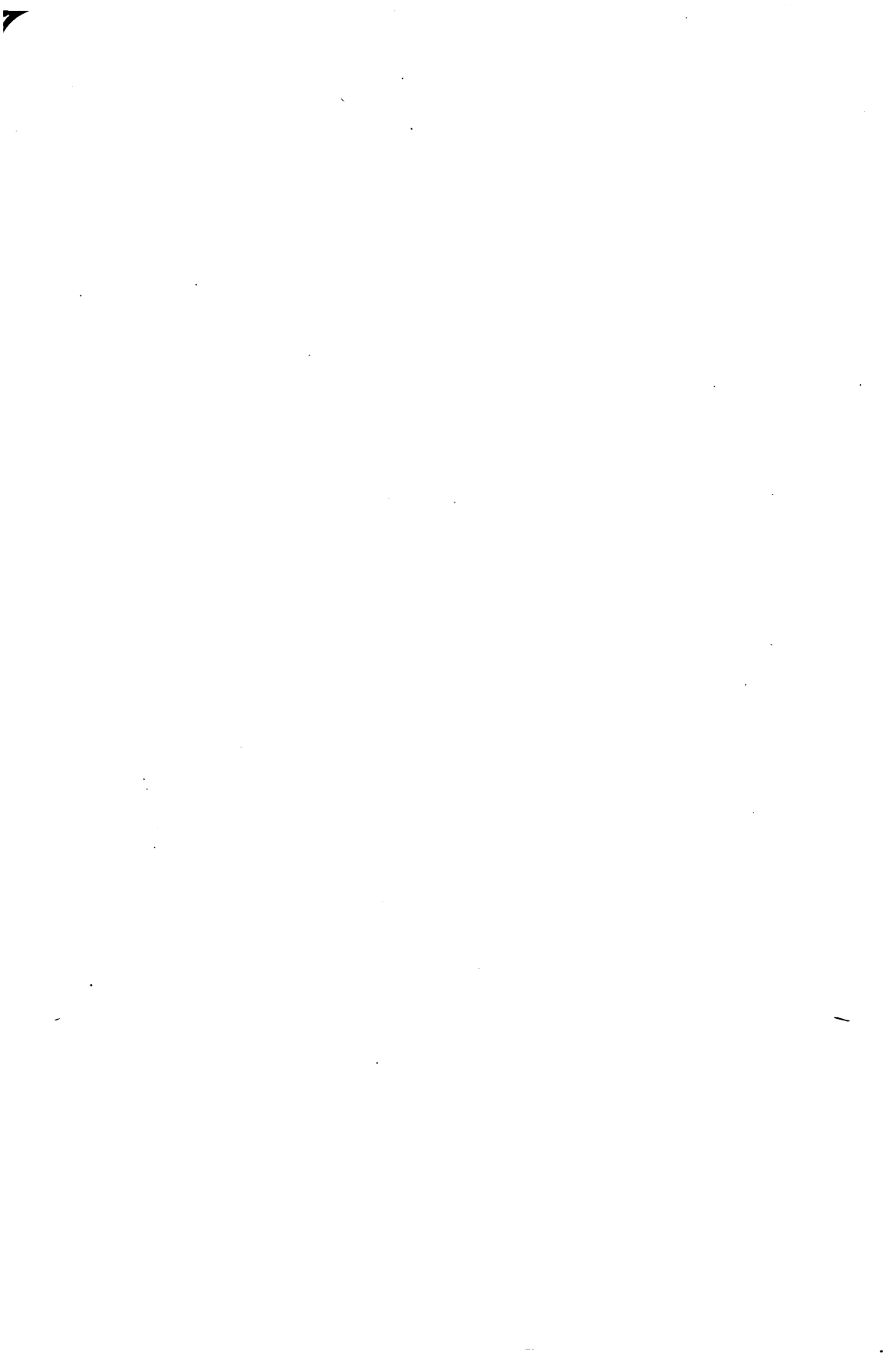

CHAPTER XVI.

PREPARATION OF CORE STOCK.

IN the process of building up reinforced wood bodies for pianos, furniture, automobiles and interior trim there is what is called a "core," or center; the proper preparation of which is of great importance to the finished article. This center, being the foundation of the structure, must be right; otherwise the quality of the finished article will be defective. It has been thought by some that the core being covered by outer layers requires little attention, as all defects in material and workmanship are hidden from view, and will never be revealed, but a greater fallacy can scarcely be conceived. Of course, this core does not require the same high quality of material that is needed for the outer, or face layer; but the contention that anything is good enough for corestock is the one we wish to combat.

THE CORE

Core stock should be sound, and may be of almost any kind of wood grown on this continent; the kind to be used depending entirely on the use to which the finished article is to be put. Because of its strength and shock-resisting powers Sitka spruce is used for airplane work; while in the manufacture of furniture and pianos the wood selected is usually such as will approximately match the texture of the veneer or crossbanding with which it is to be united; although quite frequently cost is the prime factor in determining the kind of wood used for this purpose. But less depends on the variety of wood than on its preparation for the work in hand.

When we say that wood for core stock should be sound we mean free from checks of various kinds. There is a great deal of wormy chestnut used for this purpose, and to this there is no serious objection unless it is so badly eaten as to destroy the surface for the glue; and this is hardly conceivable.

CORE STOCK
SHOULD BE
FREE FROM
CHECKS

Only one variety of wood should be used in each

core. If two kinds of wood are glued together in one core, say, basswood and birch, there is sure to be trouble which may not show itself until after the goods are finished. The swelling of these two woods as a result of the action of the moisture from the glue will not be in unison; neither will the shrinking be uniform; and an uneven surface will result in consequence.

CORE STOCK
SHOULD BE
DRIED

After the core stock has been glued up it should be sent to the drying room in order that the joints, which have swollen from the action of the water in the glue, may shrink back to their normal position. If they are not allowed to dry out properly before being planed there will be more than the proper amount of fiber removed from the swollen joint, with the result that when the joint has dried out it will have shrunk below the level of the surrounding wood; and the depression thus made will show after the stock is finished, unless a very heavy crossband has been used.

CROSSBANDING

For the better grade of work core stock is always crossbanded. This crossband consists of a sheet of wood glued on each side of the core, with the grain of the one running crosswise of the grain of the other; the object being to reinforce it to prevent checking, twisting or warping. It is the practice in some shops to lay this crossbanding at the same time that the face veneer is laid; but this plan is not here recommended, nor is it followed in the best shops. The plan adopted by those who have the best quality of work in view is to lay the crossbanding by itself and, after taking from the press, pile it away in the drying room with strips between each piece to dry out before laying the face veneer.

FACE VENEER
IS THIN

Laying the crossbanding in advance of the face veneer has several distinct advantages over the laying of both at the one time; chief of which is the better opportunity it affords of properly preparing the surface for the face veneer. Fine face veneer is usually cut very thin, and any unevenness in the surface to which it is glued will be reflected through it after the stock is finished, and will detract considerably from the quality of the goods as well as add to the cost of

finishing. Crossbanding, on the other hand, is usually cut much heavier than veneer intended for face work, and is rotary cut; that is, it is sliced, or peeled off the outside of the log as the latter is revolving in a lathe. The method of cutting crossbanding makes it difficult to get a surface sufficiently smooth for fine face veneer without some cleaning up; and this cleaning up can best be done after the crossbanding has been fastened to the core.

Allow the crossbanded core to remain in the drying room a sufficient length of time to become properly dry before doing anything toward cleaning it up; otherwise there is danger of weakening the glue-joint. The length of time required for this will depend on the capacity of the drying room; but in a room such as that described elsewhere in this book, from three to four days will be sufficient to eliminate all danger of the cleaning-up process affecting the glue joint; and render it sufficiently dry to receive the face veneer.

ALLOW THE
CROSSBANDED
CORE TO DRY

This cleaning-up is usually done by putting the stock through the sander. If the surface is in pretty bad shape, use two or more drums, with coarse paper on each; no fine paper being used for this operation. It is better to use more than one drum for cleaning up, taking shallow cuts, rather than one drum and a deep cut, as the shallow cuts are less apt to affect the glue by heating.

It is very important to have the crossbanding thoroughly dry before it is laid. There are some who have the idea that, while it may be important to have the face veneer dry, the condition of the crossbanding is not a matter for any concern. These people have their troubles in consequence of their neglect in this connection; but they ascribe the cause to something else, and consequently they never find it, and, therefore, do not remedy it. The writer has seen *face* veneer broken across the grain in consequence of being laid on crossbanding which has not been properly dried before it is laid. It was $\frac{1}{8}$ -in. crossbanding and had checked in the process of drying after the face had been laid; and at the point of these checks it had exerted sufficient

CROSSBANDING
SHOULD BE
DRY

force to rupture the face veneer above.

What we have said about the importance of using only one variety of wood in a core applies with equal, if not greater, force, to the use of crossbanding; for the nearer our work brings us to the point where the face veneer is to be laid, the more the necessity for care. If one has a lot of odds and ends of stock of various woods that he wishes to use up, it may be done by sorting the lot over and separating each kind of wood; and if there is a difference in thickness, separating these, too. These should then be dried and cut to required size, then taped ready for use.

There is always a right and wrong side to rotary cut stock; and the thicker the stock, the more pronounced is this distinction. The right side of the stock is that which was on the outside of the log during the process of cutting; and the wrong side is that which was the inside of the sheet as it was peeled off the log. To illustrate. Take a long, narrow piece of paper and bend it in a circle. The outer side of this circle of paper corresponds to the right side of the crossbanding, and the inner side to the wrong side as it leaves the log. Now straighten the paper out and note closely in your mind what follows. Imagine the paper to be $\frac{1}{8}$ -in. more or less thick, and see the strain there is on the inside as we straighten it out. The strain is more than the fibers can withstand; and they break and separate. This side with the ruptured grain and fiber is the wrong side of the stock.

The crossbanding should always be laid with the right side out—the wrong side being as far from the face veneer as possible. The right side is much more easily cleaned up; and what is more, if the wrong side were left up, the ruptured fibers and resultant scales would be so affected by moisture from the glue and subsequent atmospheric changes that they would impart a corrugated appearance to the face veneer.

The right side of crossbanding is the side to be taped, so that the tape will be removed when cleaning up for the face veneer. But this applies only to crossbanding that is laid in advance of the face veneer. If

DO NOT
MIX
STOCK

RIGHT AND
WRONG SIDES
OF CROSS-
BANDING

RIGHT
SIDE
OUT

the crossbanding and face veneer are to be laid at the one time the wrong side of the stock is the side which, in this case, should be taped, in order that it may be laid next to the core and as far from the face veneer as possible. The joint between the tape and the wood is not as firm and strong as a glue joint between two pieces of wood made under pressure. There is always danger of the tape coming loose—hence the reason for having it laid as far as possible from the face veneer.

As before intimated, crossbanding is cut in various thicknesses; the thickness to be used to be determined by the nature of the work in hand. Crossbanding is done to add strength—to reinforce the thing crossbanded; and unless the crossbanding is of a suitable thickness to match the core it will be a source of weakness and not of strength.

If one is making thin panel stock to be made five-ply, in the very nature of things everything must be thin—probably $\frac{1}{8}$ -in. core with $\frac{1}{20}$ -in. crossbanding and $\frac{1}{30}$ -in. face. But if one is making a heavy buffet top and crossbanded it with $\frac{1}{20}$ -in. stock he would very likely be building into it trouble for the future. Such thin crossbanding would not be a source of strength to a heavy top that needed to be reinforced; and if not a source of strength, then it becomes a dangerous source of weakness. Should such a core have a tendency to warp, such a thin crossbanding would be more likely to break under the strain imposed than to offer any effective resistance; and if this happened, the last state of the top would be worse than the first. Nothing less than $\frac{1}{8}$ -in. stock should be used for crossbanding $1\frac{1}{4}$ -in. core; decreasing or increasing in thickness as the requirements of the core demand.

CONDITIONS
AFFECTING THE
THICKNESS
OF THE
CORE STOCK

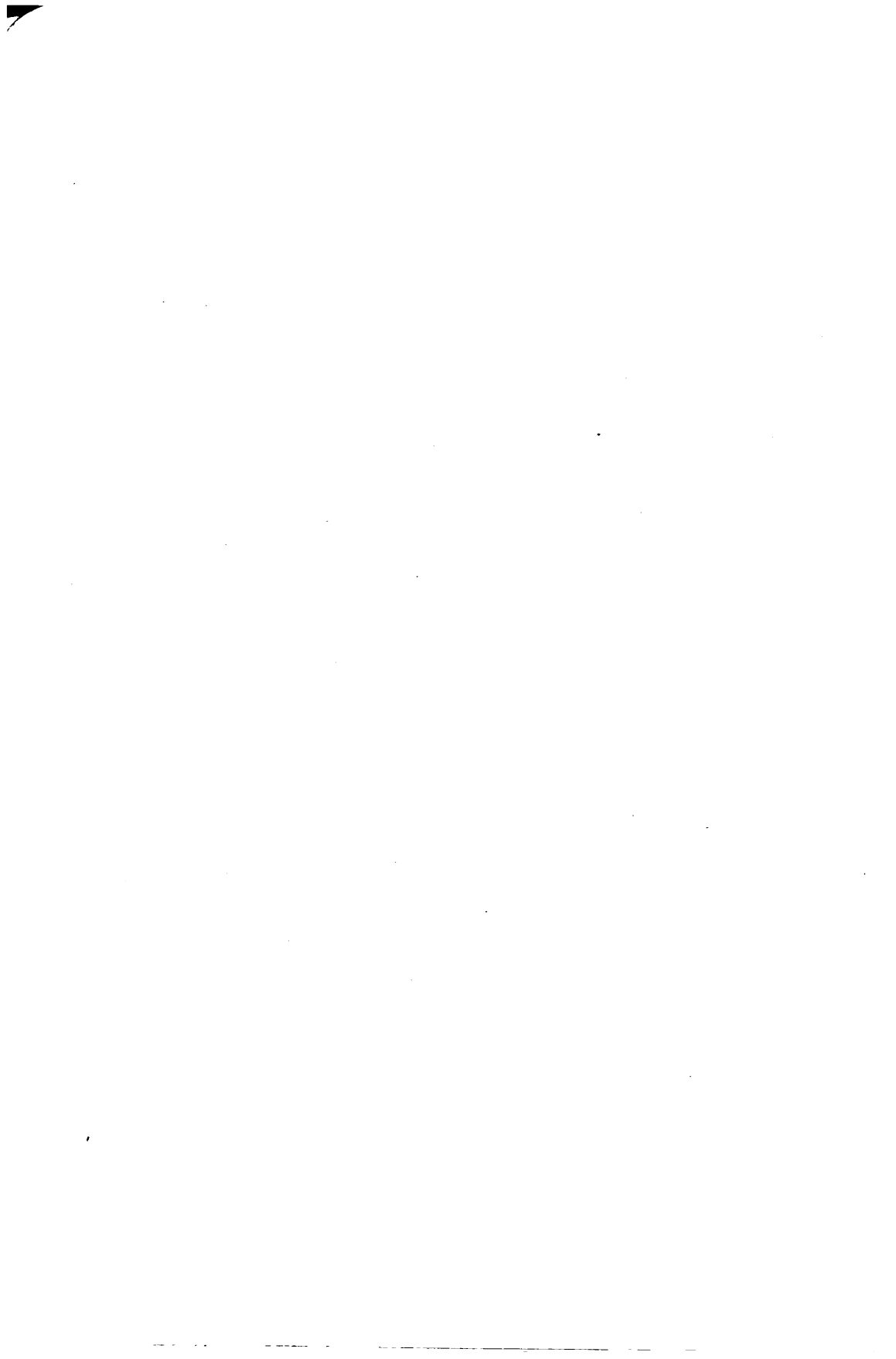

CHAPTER XXVII.

PREPARING GLUE FOR USE.

THE task of preparing the glue required for the day's work should never be entrusted to a novice, but to a person of high intelligence and long experience. Much depends on how this work is done—a mistake at this end of the line may prove disastrous to the whole output of the day.

While a person of experience is preferred in the preparation of glue for use, any man of good intelligence with experience in its use can soon grasp the essential points and become proficient at the work. But it cannot be done in an hour, nor in a day, and for this reason every glue room should have an understudy who is qualified to take the place of the head glue mixer in the event of the latter being off duty.

THE GLUE
MIXER

There is a difference of opinion regarding the question of soaking glue in cold water before heating it for use. Our modern glue-mixers have made it possible to reduce glue to the liquid state in a comparatively short time without previous soaking; at the same time the writer favors soaking first where this can be done without deterioration of the glue, as it is not good for the glue while in the dry state to be plunged into hot water, or even into a hot glue solution. But if the glue is put into the dissolver with cold, or even lukewarm water, and the temperature of the whole raised gradually, no injurious effects will result, and previous soaking is, therefore, unnecessary.

Much glue is injured in the process of soaking, especially in hot weather. It is put to soak too far in advance of requirements the process of decomposition sets in before it reaches the heater. If the glue can be kept at a low temperature while soaking, no bad effects will result from soaking over night, or even a few hours longer. If one has more glue soaking than will be required for the first three or four hours' work it would be much better to leave it in the cold soak than to

GLUE IS
INJURED
IN SOAKING

DO NOT
MIX OLD
AND NEW
BATCHES

put it in the hot heater, which would hasten the process of decomposition. Glue that is kept in the soak may be added to the heater at intervals as required; but it would be better to always empty the heater before adding fresh glue. The reason for this is: Heat deteriorates glue, and the process of deterioration begins soon after a certain temperature has been reached. The change is very slight at first, nevertheless there is a change; and if we add fresh glue with some of the old remaining, the deteriorating effect of the heat on the old glue is increasing until, by the end of the day, that which remains of the early morning lot has decreased in strength probably 50 per cent. I do not mean that all the glue in the heater has deteriorated to that extent—only the original lot, which, being mixed with fresh

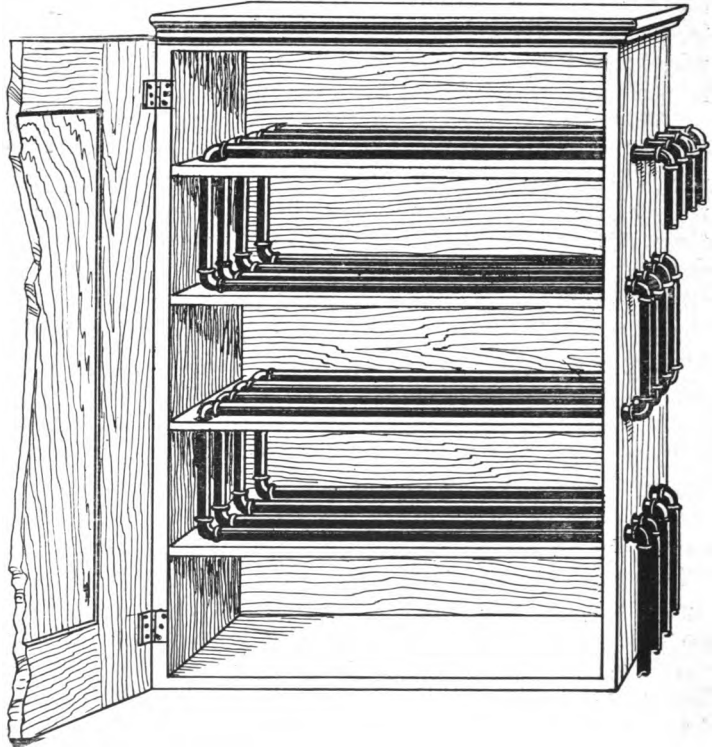

FIG. 18

glue, has saved itself from being rendered practically useless for permanent work; but saved itself at the expense of the glue that was added from time to time by distributing itself throughout the whole.

There is always an advantage in having glue soaked ready for the heater, as, in case of emergency, one can prepare it in a very short time and more easily regulate the supply for the day's requirements. And where one must soak the glue, some method for keeping it cool and prevent a lessening of its quality should be adopted. For this purpose a cupboard with shelves (Figure 18) on each of which is placed a coil of water-pipes with cold water running through them and on which the pans of soaking glue are placed, will keep the glue at a sufficiently low temperature to prevent injury within a reasonable time. The water which runs through these pipes need not be wasted, as it can be turned into the reservoir and saved for boiler purposes.

The idea that glue must be "cooked" before it is ready for use has long since been exploded. Time was when men thought that glue would not hold unless it was heated to the boiling point and kept there for some time—all the way from one to three hours. And this was done, all unconscious of the fact that each minute of sustained heat was eating at the very life of the glue and lessening its adhesive qualities. In those days men talked of glue "cookers;" but with the passing of the cooking idea there passed away also the words which gave the idea expression; and in their place have come the words "heater" and "dissolver," which signify just what they are expected to do.

While one must not cook animal glue in preparing it for use, it must not be used cold or at too low a temperature. There is a tendency on the part of some people to rush to the other extreme when the danger of one extreme is pointed out to them. Some have reasoned that if heat injures glue, then the proper way to use it is cold; and they have tried to do this, but with disastrous results. The proper temperature at which to use glue to obtain best results is 140 to 150 degrees

"COOKING" IS
UNNECESSARY

GLUE
HEATER

A THERMOME-
TER IS
NECESSARY

Fahrenheit; and as soon as it reaches this temperature it is ready for use. Every glue heater should be equipped with a thermometer for registering the temperature of the solution. No matter what else one has or has not, a thermometer should be considered an indispensable part of the glue room equipment.

CLEANING
VAT

As a preliminary to each day's operations the greatest care should be exercised the evening before in cleaning up all the glue room utensils. If these are not kept clean, the stale glue adhering to them will become mixed with the day's preparation and set up a deteriorating influence. For this purpose a vat, of the required size, filled with water into which the utensils may be placed to soak away the old glue, will be of great advantage; then in the morning they may be rinsed clean with clear water, which will take but a few moments. The vat should have a drain pipe at the bottom with a valve to facilitate cleaning, and should be emptied and refilled each day, otherwise it will soon become foul and offensive.

KEEP THE
GLUE ROOM
CLEAN

Every glue room operator should contribute his share toward making working conditions as pleasant as possible. The glue room may be made a pleasant place in which to work if ordinary care is exercised, but if neglected it is liable to reach the opposite extreme. If the floors, benches and machines are kept clean from the start they will give very little trouble, as but little time is required to keep them clean if they are cleaned daily. But if they are allowed to go on for days, and sometimes weeks and months, daily accumulating fresh coats of glue, the condition will soon become such that no man with any regard for his personal comfort or any knowledge of the rules of health would remain in the room longer than would be absolutely necessary. The benches should be scraped and the floor washed with hot water. A few minutes the last thing before leaving at night will make everything clean and sweet and put the room in such shape that one will not dread to enter it in the morning.

The careful and economical glue mixer will keep in touch with the progress of the work in the gluing-up

department in order to know how much glue to keep in course of preparation, and not have any left over at the end of the day. In warm weather glue that has been left over from the day before will seldom be fit for use and is usually thrown away. There is a great quantity of glue wasted in this way, and it ought not to be. With glue soaked ready for heating, it would be a very small matter to prepare an additional lot, should the day's supply run out before the day is done, and there need be no hold-up of the work or time wasted. In view of this there is no excuse for having a quantity left over to be thrown away and wasted.

Decomposition of glue is frequently hastened by the water with which it is mixed. If this water contains organic impurities, the process of decay will commence as soon as the water and glue come together. The value of glue may easily be reduced one-half by the use of impure water.

USE PURE
WATER

There are many things to be found in water which will injure glue. Water drawn from extremely deep wells, as well as river water which flows over a limestone bed, will frequently contain a sufficient quantity of lime or iron or other chemicals to seriously injure the glue. Some concerns that use a large quantity of glue have found the ordinary sources of water such a menace to their glue that they adopted the use of distilled water for mixing purposes. Water from the boiler, or water into which steam from the boiler has been condensed ought not to be used for mixing glue. Most boiler compounds are injurious to glue, and condensed steam from the engine is most certain to contain a quantity of grease or oil. Where it can be obtained, clean, fresh rain water should be used for mixing glue; or if this is not obtainable, some means should be adopted for purifying the water, either by filtering or distillation.

RAIN WATER
IS GOOD

Water containing an excess of lime may be purified by adding one-half pound of ordinary washing soda to a thousand gallons of the water. The effect of the chemical action produced by the soda will be the precipitation of the impurities to the bottom of the ves-

SODA WILL
PURIFY

sel. But one must be careful and not use the soda in a larger proportion than the above, as washing soda is an alkali, which, in certain proportions, would be injurious to the glue, and the last state would then be no better than the first.

It is very difficult, except in the open country, to obtain rain water that is not impregnated with impurities, such as soot, etc., gathered from the air in its descent to earth. Such impurities may be removed by filtering the water through charcoal. Place several layers of burlap in the bottom of a barrel or tank, over which place a foot or so of powdered charcoal, and let the water filter through this. The tank should be cleaned out at intervals, the length of which must be determined by the condition and quantity of water to be filtered.

PREPARATION
OF GLUE

The proper preparation of glue for the wood-working plant requires considerable knowledge; especially is this so in the preparation of glue for the veneer room. One must know the kind of glue he is using, also the kind of wood on which it is to be used. Different glues require a different percentage of water in their preparation, and different woods require a glue solution of a different consistency. Hard, close-grained woods, such as maple and birch, do not require as heavy a glue solution as basswood or poplar, which, while close-grained, are soft and absorbent and will imbibe a lot of glue; nor yet as heavy a solution as oak, which, while hard, is very porous and will absorb a large quantity also.

GRAIN OF
THE
WOOD

Where one has to prepare a glue solution for one kind of wood, say, a hard wood or a soft wood, it is a comparatively easy matter; but where one is called on to prepare a solution to meet the requirements of two; the problem is perplexing, as one cannot have a thin and a thick glue both in the one solution. But the glue room is sometimes expected to do more than its share; and this is one of the instances. As a matter of fact, one cannot prepare a glue solution that will meet the requirements of the two extremes of hard and soft woods unless these two woods will come part way and

partially meet the requirements of the glue. This difficulty is probably met with in the preparation of glue for the veneer room more frequently than anywhere else.

As before said, where two kinds of woods are to be glued together, both glue and wood must go part way to meet the requirements of the other. Suppose we are laying a poplar crossbanding on a maple core. Here is a case where the core requires a thin glue and the veneer a comparatively heavy glue. In a case of this kind we will have to prepare the glue to meet the requirements of one of the woods, and prepare the other wood to meet the requirements of the glue. In this case the correct plan would be to prepare the glue to meet the needs of the soft veneer; and prepare the hard maple core to meet the glue. This can be done by preparing a heavy glue solution for the veneer and raising the fibers of the hard core by sanding with coarse paper.

A PROBLEM
SOLVED

But let us reverse the situation and bring out a lot of hard veneer to be laid on whitewood or basswood cores. For obvious reasons we cannot machine sand the veneer as we did the hard core in the other instance, and the process of hand sanding is too slow and expensive to be considered; so we will have to again prepare the glue to meet the requirements of the veneer, only it must be made thin this time, and face the problem of how to prepare the soft core to meet the requirements of the glue. The problem thus presented is solved by glue-sizing the soft core with a thin glue solution; thus sealing up the pores and neutralizing its absorbant qualities. This glue-size should become quite dry before the gluing-up process begins.

USING A
GLUE SIZE

The proportion of glue and water to be used in preparing the glue solution for any wood is determined as much by the kind and quality of the glue as by the wood on which it is to be used—usually, if not always, the proportion of water increasing with an increase in the quality of the glue. And in the preparation of glue there should be no guesswork. The strength of the glue should be known as well as the requirements of

THE GLUE
SHOULD BE
WEIGHED

the wood on which it is to be used; and the glue should be weighed and the water measured. I wish to emphasize the importance of weighing the glue, because in the minds of some, it is so much easier to measure glue than it is to weigh it; and they follow the course of least resistance. But a bushel of glue does not always weigh the same—that is, one bushel of glue may weigh several pounds more or less than another bushel of even the same grade of glue—the weight depending largely on the condition of the glue. A finely ground glue will rest more compactly in the measure than would be the case with coarse, flake, shell or cake glue, and, therefore, weigh more; the weight increasing with the fineness.

After one has ascertained the requirements of any given wood, as well as the proper glue solution to meet these requirements, he should make a memorandum of the facts and preserve the data for future reference; as it is not safe to trust to memory in a matter of such importance. This memorandum should contain all the known facts concerning the glue; including the result of all tests, if tests of a specific nature have been made.

The great range in the quality of different glues makes it inadvisable to frequently change the make unless one has a well equipped laboratory for testing the article. Even then the practice is a questionable one from an economical standpoint. When one has a glue made by a reliable concern that has met the requirements of the past there should be some greater reason than a mere desire to try some other kind before a change is made. If one has a laboratory for thoroughly testing glue it would be well to be always on the lookout for something better and cheaper; and whether a proposition to change glue is advisable or not can be ascertained by testing a sample. But where there is no proper equipment for testing glue, the glue room operator is placed at a disadvantage each time a change is made, in that he must learn his glue all over again; and perhaps spoil considerable work before he understands it.

BE CAREFUL
IN CHANGING
BRANDS

CHAPTER XVIII.

IDEAL SURFACE FOR GLUING.

THE fact that there is such a thing as an ideal surface for gluing or one that is more likely to make a permanent job than another, has been recognized as far back as the time when all woodworking was done by hand; for in those days the wood-worker had his tothing plane with which he made very fine grooves in the wood for the purpose of removing the smooth, polished surface made by the hand plane in the process of cleaning up the surface preparatory to the gluing and laying of the veneer. Good glue will retain its hold for some considerable time on any good, clean surface; but where one desires a glue joint that will be permanent, and one that will outlive the maker, he should give special care to the preparation. The proper preparation of a surface for gluing is a comparatively easy matter today, because of increased facilities for doing the work. It is pretty generally recognized and admitted that the ideal surface is one that is perfectly level and on which the fibers of the wood are sufficiently loose to allow the glue to penetrate and secure a firm hold; at the same time not sufficiently so to allow the glue to accumulate in quantity and prevent any surplus squeezing out.

THE GLUE
SURFACE

In preparing such woods as maple and birch, and other hard, close-grained woods, the drum sander, with but one drum fitted with coarse paper, will prepare a surface which, everything else being equal, will make a glue joint that will last away beyond the lifetime of the man who did the work.

HARD WOODS

It may not always be convenient to use the drum sander for the purpose of preparing corestock for gluing; then the scraping machine may be used for the purpose. In fact, for some woods the scraper is preferable to the sander. For instance, such woods as oak or chestnut, which have hard and soft places, the sander is liable to press deeper into the soft places than into

the hard; and an uneven surface will be the result. With the scraper it is different, as the cut will be uniform over the hard and soft places. A special blade for this work is now made by some manufacturers of scrapers.

Difficulty is frequently experienced in making a glue joint on end wood, or in gluing the grain side of one piece to the end wood of another. The cause of the difficulty is usually in the end wood, which absorbs all the glue. Or in cleaning up the end wood it may be polished too smooth; or in cutting, the saw may have burned it smooth and hard, which is likely to be the case with a hard wood like maple and birch and sometimes even walnut. In this latter case the remedy is to remove the hard surface with sandpaper, rubbing sufficiently to merely break the polish.

If the end wood is open-grained or otherwise of an absorbing nature it would be well to glue-size it to seal up the pores, using a thin glue for the purpose. This is advisable on such woods as basswood and poplar and even oak.

GLUE SIZE
END GRAIN

The preparation of the glue joint between boards for building up corestock, or for other purposes, is equally as important as that for veneering. Here, as elsewhere, to insure a permanent joint the surface should not be smooth and hard. A good glue joint, that is, one made with a high grade glue and with the surface of the wood in an ideal condition, should never open under normal conditions. Of course, if a glue joint becomes soaked with water, unless it is a water-proof glue, it will open. But under what we may call the average condition the wood will break before the glue will give way.

GLUING
EDGES
TOGETHER

In addition to the proper preparation of the surface the edges of the pieces to be glued should not be made perfectly straight, but should be made slightly hollow to insure permanency. The writer was once consulted regarding the cause of open joints and on investigation found that the joints were being made slightly rounded—that is, the boards were made slightly wider in the center than at the ends. The object being to facilitate

clamping up, as only one clamp on each end of a four-foot board was being used; the argument being that there was sufficient spring in the center of the rounded board to take the place of clamps.

But the man who conceived the idea of gluing up stock in this manner had overlooked a very important factor in determining the quality of the joint, and that is, the spring supplied to the center as a result of the rounded edge of the board was a permanent force, and one which operated two ways; for while it gave pressure to the center when clamping up, it was forcing the joint apart at the ends when the clamps were removed. This force, together with the fact that the ends of a glue joint always dry out more rapidly than the parts farther in and which creates a strain on the ends which dry out first, was sufficient to draw the joints apart; in some instances breaking the wood in the immediate vicinity of the joint.

ACTS BOTH
WAYS

An ideal edge for gluing up is one that is slightly hollow or concave; that is, when the two edges are placed together they will meet at the ends only, gradually and slowly separating toward the center. This requires more force and more clamps to bring the edges together than is the case with the rounded edge; and although the spring or force resulting from the concave edges is a permanent one, it is evenly distributed from the center to the end, and is so located that it is comparatively harmless. In any event, the strain is in the center and far away from the ends, where glue joints usually open. Not only that, but it is a positive help to the ends, as it increases the pressure of each piece toward each other at these points instead of away from each other, which tends to permanency.

CONCAVE
EDGE IS
IDEAL



CHAPTER XIX.

THE COVERING CAPACITY OF GLUE.

EVERY manufacturer, regardless of line, is interested in the covering capacity of the glue, for it is this point, all other factors considered, that determines the cost of the glue. We know that high-grade glues will take more water than low grade; on the other hand, high-grade glues would prove too expensive for certain purposes, as, for instance in the manufacture of paper boxes. Again, one would not use high-grade glues in veneering, regardless of cost, because they set too quickly. We know that liquids having the same specific gravity will cover the same amount of surface. Also, as has been previously explained that glues can be prepared to give the same viscosity tests (varying proportions of water and glue), hence, the liquids being the same, they will cover the same amount of square surface.

HIGH GRADE
GLUES SET
TOO QUICKLY
FOR VENEERING

The following table was published in *Glue*, June number, 1911.

COVERING CAPACITY PER 1 POUND DRY GLUE OF STANDARD AMERICAN GLUE GRADES (BASED ON PETER COOPER GRADES):

Glue Grade.	Yield of Liquid Glue per 1 lb. Dry	Covering in Square feet.	
A Extra	3.65	79	
1 Extra	3.45	75	
1	3.34	72	
1X	3.08	67	
1¼	2.94	64	
1⅜	2.82	61	
1½	2.68	58	
1⅝	2.55	55	
1¾	2.43	53	
1⅞	2.31	50	
2	2.19	47	

COVERING
CAPACITY

It is to be regretted that glue prices have been so uncertain, and will likely be so for some time to come that we cannot cite a correct example as to possible savings, however, one can easily figure differences in

the spread costs from the figures given in the table. For example, A Extra will with 1 lb. dry glue cover nearly 70 per cent more surface than can be covered with 1 lb. dry glue of the grade No. 2.

DETERMINE
THE SPREAD
COSTS

The writer has always advised his clients to determine the cost of spread from the cost records. The cost scheme should show the number of square feet covered in your veneering, joint, or to whatever line or use your glue has been applied. You know or should know the amount of glue used, and this will give the spread cost. Having established a fairly accurate amount, use this glue as a standard in future spread tests or comparisons. This can be done in a fairly safe measure by comparing viscosities.

MUCH GLUE
IS WASTED

Someone may ask the question, "Why not determine the glue spread from laboratory tests, dissolving a certain quantity of glue and determining the surface covered?" My answer is, we may select the finest and most economical glue that money can buy, but unless the gluing department is right and the men apply and use glue correctly our spread test would avail us nothing. Your records should show what your glue costs are, and this is the real check on your gluing department. We will find some glue rooms equipped with the old style glue pots and the glue applied with a brush. We will find other modern rooms employing the latest types of glue-spreaders and find they cover a greater surface than the men daubing the stock and likely wasting from ten to fifty per cent. If the surface of the stock covered is accounted for, the glue buyer will know that something is radically wrong. Yes, it is well to get a line on your spreading by testing, but in the name of common sense do not depend upon these tests.

Suppose you buy a glue worth, say, thirty cents. It passes the required tests and is a pure hide product. The men in your glue room, however, abuse this product by overheating so that when actually used it is worth but twenty-five cents. What good was derived from your tests? Why not buy the twenty-five cent product in the first place and save the five cents that you are actually wasting? Therefore, our tests and the

actual final result must be considered. When you know beyond the shadow of a doubt that your glue is properly used and you are getting one hundred per cent glue room efficiency then you can apply the information given regarding the spread of glue, but until this degree of efficiency has been attained, your assumed spread cost is unreliable and cannot be depended upon.

ARE YOU
GETTING 100
PER CENT
EFFICIENCY?

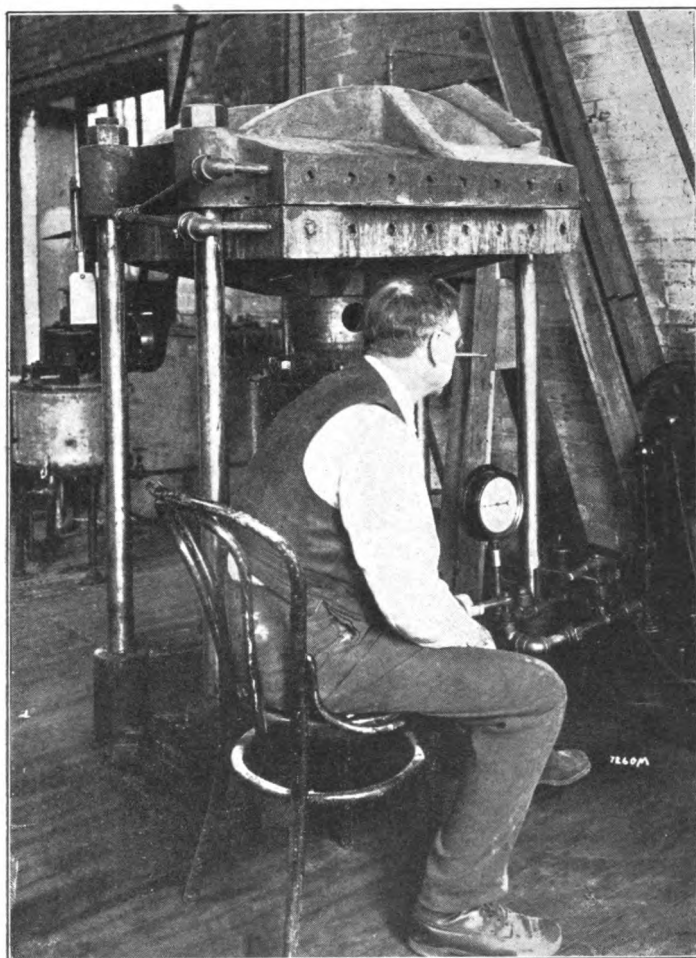

FIG. 19

CHAPTER XX.

GLUE ROOM EQUIPMENT.

COMING to the practical end of the use of glue, we would say that in this day of rapid processes one must have a modern, up-to-date equipment in order to obtain best results. It is true that some very fine work was done in the olden times when the glue pot and brush, and the clamps or hand press comprised the entire glue room equipment, and the glue brush and pot had to compete with the glue brush and pot; and the clamps and hand presses had to compete with the clamps and hand presses. But times have changed; and one might as well expect the old stagecoach to compete today with the modern railroad flyer, or the old hand sickle to compete with a modern harvester, as to expect the old fashioned glue room equipment to compete with modern appliances. It is not merely a question of quality of work; but in these times of keen competition time and cost are important items. Nor is this all. To do the amount of work demanded of the modern glue room in one of our large modern factories—to do this amount of work with the old style equipment would require almost as much space as is now taken up by several departments; and in most factories floor space is an important matter.

MODERN
GLUE ROOM
APPLIANCES

Glue room equipment has kept pace with the onward march of progress in other spheres of activity—a steady march toward greater efficiency. All the changes that have been made in means of doing the work in the glue room have been for the purpose of making it easier to do the work in less time, and increase the quality where possible. The checking of veneer, owing to the presence of moisture before laying, created a demand for the redryer; and the tendency of dry veneer to rapidly absorb moisture from the glue created a demand for something more rapid than the hand press, and the hydraulic press came into existence (Figure 19). The same may be said of the

other modern machines. The retaining clamps and the overhead carriers came in response to a demand for economy in floor space, and to enable the one power press to do the work of many. The glue spreader (Figure 20) responded to a hurry-up order from the power press to keep it busy, as men could not spread glue fast enough with the brush. Then the modern glue dissolver came to prevent these rapid machines from



FIG. 20

standing idle while glue was being prepared during the early part of the day.

It is not enough that work be done well—it must be done in the shortest possible time and in the easiest possible way; and this can be done only by the use of the best equipment. Every manufacturer is anxious that the cost of operating his glue room be reduced to the lowest possible point consistent with good work, and the result of our observation is a firm conviction that the shops with the lowest operating expense are those with the best equipment. The first cost of the plant is undoubtedly greater, but the difference between a poor and a good equipment is soon wiped out by the saving in operating expense and the decrease in the cost of repairs.

WORK MUST
BE DONE IN
THE SHORTEST
POSSIBLE
TIME

It is not our purpose to advocate any particular equipment, as every factory must be governed by its individual needs; but we have been asked so often regarding the best kind of caul for use in the veneer room that we might be permitted to say a word about this part of the equipment. There are three kinds of caul in general use, i. e., wood, metal and fiber board. There are three kinds of metal cauls, i. e., iron, zinc and aluminum. It is not for us to advocate the claims of any of these, as many glue room operators have had success with all of them. But we will say that metal cauls should always be used where hot glue is the adhesive, because they will absorb and retain heat more readily than wood or fiber; while we have a preference for fiber cauls where a cold glue is used, because they are light in weight and easy to handle.

KINDS OF
CAULS

We have been frequently asked how best to prevent glue from sticking to cauls. In the case of fiber cauls they may be made glue-proof by repeated applications of hot parafine oil into which parafine wax has been melted in proportion of one pound of wax to a gallon of oil. Heat the oil as hot as can conveniently be done and apply it until the caul will take in no more. The idea of the wax is to add body to the oil. A caul thus treated will last for a considerable time without anything further being done to it; but to keep it in prime condi-

TO PREVENT
GLUE FROM
STICKING
TO CAULS

tion it would be well to give it a light application of the oil at intervals, the length of which will depend on the frequency with which the caul is used.

Metal cauls need something with a little more body than oil. Parafine wax has been used by some with fair success; but beeswax is better. For this purpose it is not necessary to use the genuine beeswax, as there is an artificial article that will answer the purpose equally well.

With all cauls care should be taken to keep them clean; and care should be taken in cleaning them. It is not a good plan to scrape cauls in cleaning, as this is liable to wear them thin in places, resulting in a reduced pressure at these thin points when in the press, which, in turn, results in blisters in the veneer. Metal cauls may be cleaned with steam or hot water, if one has a vat of hot water to put them in; or they may be washed off with a rag and hot water. With fiber cauls there is less liability of the glue adhering to them, owing to their thorough saturation with oil, and if any does adhere it can easily be rubbed off.

CAULS SHOULD
BE EXAMINED

But cauls should always be examined for glue before being used, as any particles which may be present will be pressed into the veneer, leaving dents which will likely rise and give no end of trouble during the process of finishing.

CHAPTER XXI.

AN IDEAL GLUE ROOM.

TO GET best results in the use of glue, whether it be in gluing up solid lumber or in making veneered stock, one must have a proper place in which to do the work. A glue room located in a basement with a seven or eight foot ceiling is not conducive to the best in glued-up work; and this for more than one reason. Such a place is unfit for the work; and a man capable of doing good work under proper conditions can easily find plenty of employment in more congenial surroundings, and, therefore, is not likely to remain in such a place.

An ideal glue room for doing veneer work is one located on the ground floor, because the light so necessary for matching fine veneers is better here than it is at a higher altitude; but for other purposes it is immaterial whether it be located there or on the second floor. If located on the ground floor, and the floor is cement with no basement beneath, it should be raised to prevent dampness.

SHOULD BE
LOCATED ON
GROUND
FLOOR

The work of matching veneers and preparing the stock for gluing should not be done in the glue room proper; but should be done in a room immediately adjoining. In this room should be the machines for cutting the veneer to size and jointing and taping. Also immediately adjoining the glue room should be the drying room; the nature and importance of which we will consider later on.

The size of the glue room must, of course, depend on the volume of work to be done, but in laying it out it would be well to make provision for an expansion of business in order to avoid hampering the work through congestion.

The success of a glue room depends a great deal on the arrangement of the equipment. If the work of gluing up the solid stock is done in the same room with the

veneering, the appliances for doing the different work should be so separated that the work of one will not at any time interfere with the work of the other. As far as possible the revolving clamps and presses for the solid lumber work should be located at the side of the room to that where the veneering is done, leaving the space between the two equipments for stock in process.

LOCATION OF
THE GLUE
HEATERS

The glue heaters should be placed in one corner of the room with the glue spreader immediately in front of them. The heaters should be sufficiently elevated to allow the glue to flow into the upper and lower tanks of the spreader. This is preferable to carrying the glue from the heater to the spreader in buckets, which is liable to chill the glue and impair its quality. The glue should be run from the heater to the spreader through a detachable pipe; and this should be taken down each night and cleaned along with the other utensils.

The veneer laying bench should be placed in close proximity to the spreader and the power press as close to this as is practical, to avoid unnecessary carrying of the stock. Near the heater is a vat into which the utensils are put to soak to facilitate cleaning. This vat is provided with a drain-pipe and valve to allow emptying every day.

SATISFACTORY
HEATING
ARRANGEMENT

The heating of the glue room is an important matter. The forced hot-air system is not here recommended, as there is too much danger of the draft coming in direct contact with freshly glued surfaces and impairing the adhesive quality of the glue. The overhead steam coil is not recommended, because it heats the part of the room first that least requires it, and the part toward which the hot air will move in any event; and in addition to this it is hard on the workmen. The most satisfactory system for heating will be found to consist of one or more coils of pipes placed along the walls about one foot from the floor, the number of pipes to the coil to be determined by the space to be heated, as well as the length of the coils.

A well conceived glue room will have plenty of head room. Where animal glue is used, the odors are not of the most pleasant sort at the best of times, but are par-

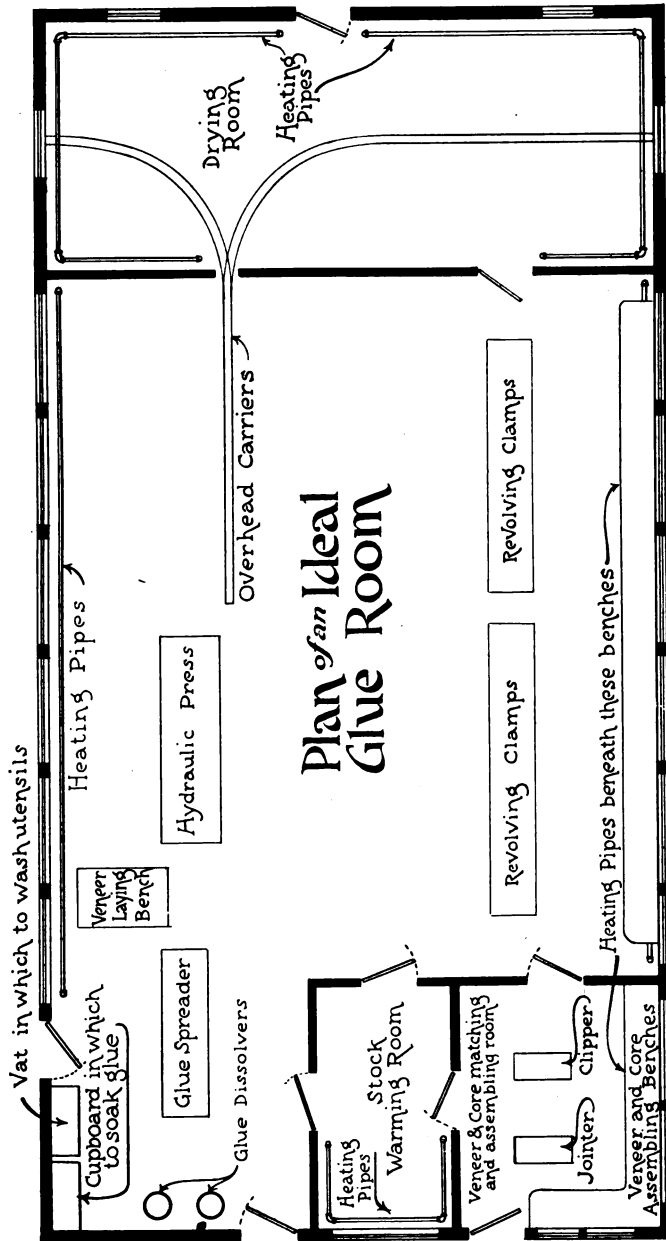

FIG. 21

A FAN
SHOULD BE
USED

ticularly nauseating in a room with a ceiling so low that one feels as though he were in the midst of compressed offensiveness. No glue room should be less than eighteen feet high, and then a fan should be installed for carrying off the foul air. This fan should be located near the ceiling at the opposite end of the room to the one where the spreader is in operation, and should revolve so as to draw the air out. This can be done without disturbing the air at any one point sufficiently to create a draft. Drawing air out with a fan is different from blowing air into a room by the same means. In the former case the air which is drawn out of the room is taken from the top and the air in all parts of the room moves upward to take the place of that which is being carried away. The movement of the air is so slow and even as to be imperceptible, there being no concentration except in the immediate vicinity of the fan. If the fan be reversed and the air blown into the room it will be forced toward a given point, creating a strong draft.

The problem of how to admit fresh air to take the place of that drawn away by the fan may safely be left to solve itself. No room is airtight and the weight of the air outside will force fresh air in to take the place of that which escapes.

THE
DRYING
ROOM

The drying room to which we referred a short time ago should be considered an essential part of every glue room equipment. This room should be divided into two parts—one part for warming stock before going in to be glued up, and the other part for drying stock after it has been glued up. The importance of warming stock before gluing, and of drying thoroughly after gluing and before working up, are both considered in another part of this book. While we advise dividing this room into two compartments, we do not contend that it is absolutely necessary to do so. What we do claim is that the two rooms have an advantage over the one room.

Where there are two rooms, one room can be used for warming the stock for gluing without running the risk of it being affected by the moisture that is being

thrown off by the glued-up stock; and into the second room the glued-up stock may be run to finish off a few hours before being worked up.

Both of these rooms should be well heated and ventilated. If the room is large it would be well to place a coil of pipes in the center as well as along the wall, as this will increase and make more uniform the circulation of the air; and circulation is essential to success in a drying room. The heating apparatus should have a sufficient radiation to keep the temperature in the vicinity of 110 degrees Fahrenheit. Ventilators should be placed in the top to allow the vaporized moisture to escape. In a several-story building, with the glue room and drying room on the ground floor, ventilators are not always practical; in which case a fan should be installed to carry off the moist air.

CIRCULATION
OF AIR
ESSENTIAL

The foregoing are the essential features of an ideal glue room connected with a wood working plant. But the IDEAL glue room would be a building one story high, with light from above as well as from all sides. Such a room would have to stand out by itself; and while it would be "ideal" from its own viewpoint, it would be inconvenient from the viewpoint of the other departments of the factory.



CHAPTER XXII.

EVOLUTION OF GLUE ROOM PRACTICE.

AWAY back in the early dawn of the glue and woodworking industry men were trying, as they are today, to do the work in the best and easiest way. There is very little literature extant which would throw much light on the very early methods of gluing up wood work, but the contrast between the methods employed half a century ago and those of the present day is sufficiently great to be startling to the old-time cabinet maker, were he to leave his Celestial abode for a brief visit with us who were left behind to "carry on" after he had gone. In the early days the clamping-up was done by means of a frame not unlike the screw clamp in use today; but the pressure was exerted by means of wedges driven between the clamp and the edge of the boards to be pressed together. In those days the glue was dissolved in a kettle on a stove and brushes were the only means of applying it to the wood. A wonderful step forward was made when the screw clamp was brought into existence. There matters rested for some considerable time; or until the trade of "cabinet maker" became divided into several different branches. In the old days the cabinet maker took the board in the rough from the yard and carried the work along, planing, jointing and gluing, assembling and finishing until the article was completed. But when the furniture and kindred industries grew to be of national importance they outgrew the old fashioned method and the one trade of cabinet making became many trades; hence it is that we have the glue room specialist of today. With the advent of the glue room specialist this department became recognized as an important branch of the woodworking industry, and some of the best mechanical brains were directed toward improving the method of doing the work, so as to improve the quality and lessen the cost.

A BIT OF
HISTORY

Then the time came when the work of the glue room

GREAT
STRIDES
HAVE BEEN
MADE

specialist was divided and some followed after the gluing-up of boards; and others followed the gluing of a face veneer on these boards. From this time on things moved with startling rapidity, so much so that a detailed account would read almost like a fairy tale. It is a long step from the old hand plane and glue brush to the modern automatic glue jointer, on which the lumber is jointed, glued, clamped and cut to size in one automatic operation; and yet it is a step that has been taken by many men yet able to do a good day's work. It is equally far from the old glue kettle sitting on a stove to the modern steam or electrically heated dissolver with its thermometer and automatic heat controller to prevent overheating and spoiling, and its power agitators to facilitate solution and reduce time and labor costs; and yet many who read this have spanned the distance. Measured from the viewpoint of accomplishment, it is a wonderful stride from the old glue brush and bucket to the modern glue spreader with its rolls designed to spread heavy or light, to spread on one side or both sides of the board, as the requirements of the work in hand may demand. The same may be said of the distance between the flatirons used in rubbing on veneers in ancient days and the clamps and clumsy hand presses of a later period; or between these and the quick-acting and powerful hydraulic presses; and from the old rack above the stove for drying veneers preparatory to gluing to the modern redryer; and yet many who will read this have lived to see it all.

MANY PROB-
LEMS REMAIN
TO BE SOLVED

All these things have tended to solve the problems of the glue room; but there are many problems belonging to the individual glue room that yet remain to be solved. Equipment alone cannot solve them. The same high quality brain power that brought these machines into being must guide them in their operations if they are to accomplish all they were designed to do. At one time many were of the opinion that a machine was a failure if a man lacking in mental capacity could not keep it in successful operation. But the fact that a machine, no matter how perfected, is, after all, but a

machine, without inert animation and but reflects the intelligence of its designer and builder in operating it, is now becoming more generally recognized.

That the foregoing contention is correct is borne out by the experience of European countries, as well as by the experience and observation of those who have investigated the matter here at home. It will, we think, be pretty generally admitted that the average inhabitant of Europe does not give evidence of that high intellectual development that characterizes the average American. This lack of mental development is responsible for the fact that in factories in Europe which are equipped with American-made machines operated by men working for a much smaller wage than is paid in this country, the cost of production is much higher there than here. These men, though steady and conscientious in applying themselves to their tasks, do not seem to have the combination of head-heart-and-hands so essential to the speeding-up methods in vogue here. J. B. B. Stryker, who had traveled somewhat extensively through Europe prior to the war and who visited numerous factories, in writing on the subject says: "Although American-made or modeled machinery is so largely employed by them, the production of the average plant, comparable with ours, as to size, equipment and number of men employed falls considerably short of the production over here." The same may be said of the factory in this country in which the average "foreign born" is placed in charge of machines so highly developed that all they seem to require is brain-power, but which deficiency the operator is unable to supply.

WHY THE
EUROPEAN
LAGS IN
PRODUCTION



CHAPTER XXIII.

FRICITION BETWEEN GLUE AND FINISHING DEPARTMENTS

FROM time as far back as the oldest glue room man's memory goes there has been more or less friction between the glue room and the finishing department; and we do not think a book dealing with the problems of the glue room would be quite complete were it not to make some effort to set these departments right in the eyes of each other. It is not our intention to take sides between these departments further than is merely incidental to the purpose of bringing order out of chaos. The great difficulty between these departments has been and now is that when defects develop in the work, each department is more interested in trying to shift the responsibility from their own to other shoulders than in trying to ascertain the real truth regarding the actual cause of the trouble. And the fact that defects in wood work are not usually discovered until some time after the goods have arrived in the finishing department and the finishing process pretty well advanced, has tended to intensify the difficulty by giving the glue room some ground for the assertion that the goods were all right when they went into the finishing room, and that some material used in the process of finishing must be responsible for the trouble.

SHIFTING THE
RESPONSIBILITY

The finishing department, on the other hand, when defects develop, is equally positive that the method of finishing is not in any way injurious to the glue or in any way responsible for the defects; and declares that the defects were hidden in the woodwork before being sent to be finished; and that had the glue men done their work right no trouble would have ensued. And thus the argument proceeds *ad infinitum*.

Take, for instance, the matter of blisters in veneered work. As a rule, these do not show themselves until the goods have received at least a coat of

VENEER
BLISTERS

WATER DOES
NOT LOOSEN
THE VENEER

stain—perhaps of water stain. Or the finisher may have sponged the stock with water to raise the grain, all of which furnishes the glue man with a lever with which to roll from his own door to that of the finishing department the responsibility for the trouble. But let us look at the matter calmly for a moment. Let us take a piece of veneered work about the soundness of which there can be no doubt, and let us try and remove the face veneer by soaking it with water, using a brush or sponge to apply the water. We put on one coat, two coats, three coats, six coats, and still the veneer sticks tight. Now if half a dozen applications of water will not loosen veneer when we want to remove it, is it reasonable to say that one coat of water stain or a light sponging with water caused the blisters in the finishing room? Let us be honest with ourselves, even if we don't want to be with the other fellow. We will be much wiser in the end if we are.

TEST FOR
LOOSE
VENEER

If veneer is well and truly laid, neither sponging nor one or two coats of water stain will loosen it. And if it be not well laid, or if there be any doubt about it, the best thing that one can do is to go over it with a sponge and water and by this test ascertain the facts. A usual test for blisters is to lightly tap the veneer with the finger, and if the response is a sharp "click" we know the veneer is loose. But this test is not always reliable, because the veneer may not be cemented to the core and yet be lying sufficiently close to prevent the telltale click when tapped with the finger; and yet the very moment it is touched with water it will raise in a blister. Now why is this so? Let us explain:

The normal state for the veneer would be lying close to the core; it was that way when it left the press, and there has been nothing done since to change this condition. But when we touch the veneer with water we change the normal condition by causing the fibers to swell and the veneer to tighten and become too large for the place it is in, and it raises up to relieve the strain. But it can raise only if it is already loose from the core, because if it is firmly cemented to the core the strain thus imposed could not possibly be sufficient to

break the glue joint. The same thing may be illustrated in another way: take a sheet of paper, spread it out on the table, and draw a wet sponge part way across the center, and see how quickly it wrinkles up. The moist piece at once becomes too large for the place it occupies and expands in several directions. But the paper would not have wrinkled had it been firmly cemented to a heavy body, which fact can easily be demonstrated by the simple test of trying to remove wall paper by the same process.

We recall the case of a concern which had more than its share of trouble with loose veneer and open joints, without being able to ascertain the cause for some time. The glue room men and the cabinet room foreman, under whose supervision the glue room work was done, all contended that the cause of the trouble lay hidden in the dark recess of a large oil-stain vat into which the stock was dipped on reaching the finishing room. Things were finally brought to a head by the finisher being ordered to discontinue the use of the vat; but he demanded some proof that the vat was the cause of the trouble. No proof being forthcoming, the finisher proposed to prove that the vat was not guilty as charged, and offered to submit it to any test that might be suggested. To this end a cake of glue and two or three panels which gave evidence of being sound were put in the vat and left there for twenty-four hours. Then, at the end of that time, the glue and panels were removed, without showing any evidence of ill effects from their long immersion, the management decided that they must look elsewhere for the hidden mystery, and turned their attention to the glue room. When this was done they were not long in finding what they were after, in the shape of over-cooked glue and over-heated cauls. Having made this discovery, their troubles from this source were at an end.

TRUBLE IN
ONE FACTORY

Men are not unlike mere material matter, in that they are prone to follow the course of least resistance, and in the case under consideration, when defects are found in glued-up work it is much easier to look for the cause in the immediate vicinity of the place where the

defects are first discovered and find some operation, the nature of which we do not understand, on which to lay the blame, than to make a diligent search where we are likely to find out what we are after. To be quite frank about it, it too frequently happens that neither the glue man nor the finisher is quite positive that the cause of the trouble is not in his own department, and for this reason is not very anxious to find what he is hunting for.

It is a mistake for a man to remain in ignorance of even small matters merely because he lacks the moral courage to face the truth. There is no man so perfect that he never makes mistakes. Some one has said that "the man who never made a mistake never made anything that was worth while." And it is not the man who runs away from his mistakes or tries to hide them that succeeds the best in life. On the contrary, the man who succeeds is he who acknowledges his mistakes, grapples with them and overthrows them and uses them as stepping stones to great achievements.

Let the finisher and the glue room man determine in his own heart that he will be honest with himself and honest with the other fellow. Let these two men come together with that thought uppermost in their minds when defects appear in glued-up stock; let them together search for the cause with a determination to find it, no matter where it is to be found, and each will find that he has dropped many a headache, and many a heartache as well.

PLAY THE
GAME
SQUARE

CHAPTER XXIV.

VENEERING SCROLL WORK.

ONE of the most difficult things which the man who lays veneer finds himself up against at times is the problem of getting a good, tight glue joint on the scroll and other irregular work. To overcome this difficulty, various schemes have been tried in various places, with equally varying results. The most common practice is that of applying extra pressure in the hope that in some way the low spot where the veneer is liable to be loose will be reached and sufficient pressure applied to produce the desired result.

There is one thing which it would be well for all of us to remember, and that is that everything has a cause, and that a repetition of the difficulty before us may be avoided by removing the cause. When we remove the cause, the effect must cease. The whole thing may be summed up in the maxim that "An ounce of prevention is better than a pound of cure." In the case before us, instead of applying a sufficient amount of extra pressure to crush the article out of shape, as I have often known to be done, it would be better to start at the point of the trouble and trace back until we find the cause, or the reason why the pressure is not uniform all over. Having found it, let us remove it, no matter what it may be.

FIND THE
CAUSE

Not infrequently the cause of the difficulty is in the design of the article to be veneered. It all too frequently happens that the designer is not a practical mechanic, in consequence of which the veneer man is often asked to do the impossible. Many times a slight change which would not materially affect the appearance of the article, nor alter the designer's conception, would eliminate mechanical difficulties and greatly lessen the manufacturing cost. Many designers submit their drawings to a practical man and make the suggested alterations. But there are a few who know so little about the things of which they are supposed to

DESIGNS
MUST BE
PRACTICAL

**DIFFICULTIES
MUST BE
ELIMINATED**

know considerable that they feel they must guard that little with jealous care—hence they resent any suggestions regarding the offspring of their brain. When I find one of these men I cannot help making him an object of mingled pity and contempt. Pity because he is small, and will never be any bigger. The designer who is worthy the name has nothing to fear. He is a big man in the profession. He has had his eyes open to see and his ears open to hear anything that might be suggested to him. But the small man—he is small because he refused to open his mind to imbibe that which would have made him big. Under the most favorable conditions it is not an easy matter to get a first-class, dependable glue joint on scroll work; hence the importance of eliminating everything that would make it more difficult.

**A LESSON FOR
BEGINNERS**

But even where every care has been taken by the designer to remove all unnecessary difficulties, it is not always possible for the veneer layer to produce the desired result, although through no fault of his own, and in consequence of something over which he has no control. It is the common practice, and rightly so, to use as a caul the piece bandsawed from the scroll. Now, in order to make ourselves quite clear, let us discuss the matter before us as though we were presenting it to a class of boys in school. Let us take the scroll to be veneered and lay it on its side on the bench; then take the piece which was cut away, and which we are to use as a caul, and lay it beside the scroll, being careful to have the two pieces separated by the thickness of the saw which was used to cut the two apart. Having done this, we will look along the various curves and lines and we will observe that at all points the distance between the two pieces is exactly the same. If we move them a little closer together we will observe that at certain points they are nearer each other than at other points. The same thing will be seen if we move them farther apart instead of closer together. If we move the two pieces together until they meet we will see that they touch at certain points only. Now, in what we have just pointed out is to be found the reason why it

is so difficult to get a good, tight glue joint between the veneer and the surface of the scroll on which it is laid; and in the same thing is to be found a solution of the problem which the subject presents. To illustrate:

Suppose we bandsaw a scroll, using a saw set to make a cut 1/20-in. in width. Having done this, we place the scroll and the caul on the bench separated by exactly 1/20-in. at any one point and we will see that they are an equal distance apart at all points. Now take a piece of veneer 1/20-in. in thickness and slip it in between the caul and the scroll, and you will find that the fit is perfect at all points.

Now, suppose we remove the 1/20-in. veneer and substitute a piece 1/30-in. in thickness, and press the caul and scroll together to fill in the space resulting from the difference in the thickness of the two veneers and we will find that at certain points the veneer is tight, while at other points it is quite slack.

Now, let us remove the 1/30-in. piece of veneer and fill the space with a piece 1/16-in. thick and we will find the conditions the very reverse of what they were before; the points which were tight with the 1/30-in. veneer are now slack; and where it was formerly slack it is now tight.

All this goes to show that the problem of a tight glue joint on scroll work is in the use of a veneer exactly the same thickness as the kerf removed by the saw. Of course, there are other things of importance to be attended to. Good judgment must be exercised in applying the pressure. Where the pressure must be applied from two directions it should be applied to the smaller surface first, otherwise it may be found difficult, if not in some instances impossible, to overcome the resistance offered by the greater pressure on the larger surface to insure a tight joint at these smaller points.

VENEER MUST
BE THICKNESS
OF SAW KERF



CHAPTER XXV.

LAYING FINE FACE VENEERS.

THE first requisite to the successful laying of face veneer for fine cabinet work is the quality of the veneer itself. We may have a good core well crossbanded; and we may employ the most skilled help to do the work with the best of glue; but if the veneer is of a poor quality our work will count for naught. It is not enough that veneer be well figured to be classed as good stock; it must be well cut, and well cared for, and well dried—otherwise we are merely building trouble for the future into our work.

A great deal of our best figured veneer has the fiber so badly ruptured as to make it extremely difficult, if not quite impossible, to lay it with any degree of assurance that trouble will not develop; and for this reason one should exercise the utmost care in selecting the stock for fine face work. The more beautiful the figure of the wood, the more difficult it is to cut into veneer without doing damage to the fibers. The figure is the result of the entwining and interlacing of the wood fibers in such a way that when cut into veneer many of the fibers are cut into lengths no longer than the thickness of the veneer, which may be as fine as 1/30-in., and sometimes even less. These short fibers, which run straight, or almost so from one side of the veneer to the other, make what is called "end wood;" and unless the veneer is handled very carefully it is very liable to check at these places. It also makes it very difficult to dry without checking, as the difference in the grain is such that some parts dry out faster than others; and this uneven drying means uneven shrinking, and this sets up strains in the wood which certain parts are unable to withstand; and they break. For this reason, veneer, when once dry, should be kept dry, in order to reduce to a minimum the possibility of checking.

GOOD VENEER
IS IMPORTANT

But too much care cannot be exercised to insure the

A REDRYER IS
NECESSARY

veneer being dry before laying. It would be safe to say that nine-tenths of the trouble with veneered work results from the veneer not being dry at the time of laying; or, more properly speaking, at the time the pressure is applied. We may have the veneer thoroughly dry at the time of laying on the core, and by leaving it loose so that it absorbs moisture from the glue and swells before the pressure is applied we may defeat all our efforts in drying.

Where one has considerable veneering to do it will pay to put in a redryer. It is not our intention to advocate the claims of any one make, as all have merits worth considering; and the buyer must be guided by the work in hand and select the machine best adapted to meet his own peculiar requirements. But if one is starting in a small way, or, for instance, in a manual training school, it would not be the part of wisdom to go to the expense of installing an expensive redryer. Under such circumstances one must adopt other means to accomplish the desired result. Take boards of some soft, absorbing wood, such as basswood, and cut them in size a little larger than the veneer to be redried. Heat these boards as hot as possible in the hot-box and lay the sheets of veneer between the boards, keeping each sheet separate, and put under pressure, applying a heavy pressure for a few moments at the start to allow the veneer to heat quickly; then loosen the pressure to allow the veneer to shrink, as the boards absorb the moisture, without the danger of checking.

FLATTEN OUT
BUCKLED
VENEER

Much of the finest face veneer, such as crotch and hurl walnut, is badly buckled when dry, and cannot be laid in this condition without breaking when the pressure is applied. Stock of this kind may be moistened with water sufficiently to allow it to be flattened out with safety, then redried in the manner described above.

For the benefit of any who may not know what the hot-box is spoken of above it might be well to describe the form of construction. There are many different ways of making hot-boxes; some being made of boards, but the principle is the same in each case and we will

describe the box which we think to be the best. It is a metal box made from sheet iron. If a large box is required it is made in sections fastened together with angle-irons. The sheet-iron is made into panels, two sheets to a panel with sheet asbestos in the center. Into this box steam pipe coils are placed in such a way that they may be used as shelves; the number of shelves and the distance apart depending on the size of the box and the work to be done. This box is different from a drying room; the idea here being to get a maximum heat in a minimum time. For heating, either exhaust or live steam may be used. If a trap is placed at the outlet of the coils it will cost very little to heat with live steam. The stock to be heated is placed on the coils of pipe. There should be a vent at the top of the box to allow any moisture that may be present to escape; as the boards to be heated must be absolutely devoid of moisture to do the best work.

SHEET
IRON
HOT BOX

With the stock thoroughly dry it is ready to be jointed and taped if it is narrow stock. Whether one has a taping machine in his factory should depend on the amount of work he has to do; but one man with a taping machine can tape as much stock as half a dozen men can by hand; and as the machines are comparatively inexpensive, it would be well to give the matter very serious consideration before deciding that you can afford to do without one.

The usual method of taping veneer is to tack one piece to a board, using very fine brads for the purpose, so as not to make too large a hole, then fitting the edge of the second piece close to the edge of the first piece, being careful to match the grain and figure, and tacking it down in like manner. But this method has disadvantages as it takes time to tack the veneer to the board as well as time to remove it after the taping has been done. The tack holes must also be considered, for, no matter how careful one may be, and no matter how small a brad he may use, in some veneer the mark will show.

TAPING
VENEER

A better way to tape by hand, but one which re-

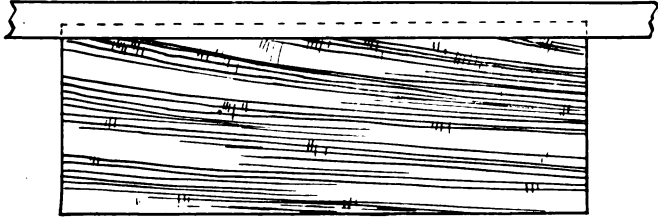

First operation: Moisten tape and run it along edge of veneer, allowing one-half to project over for the next piece

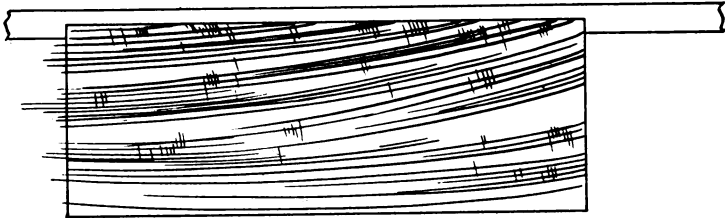

Veneer reversed with gummed side of tape up ready to receive its mate



The two pieces joined ready for laying

FIG. 22

quires some skill, especially with long joints, is to place the sheet of veneer on the taping bench with the side to be taped upward (Figure 22.) Moisten the tape and run it along the edge of the veneer; one-half on the veneer and the other half projecting over. Then turn the veneer over. This brings the gummed side of the tape upward ready to receive the second piece of veneer. Speed and skill are necessary to get both pieces in position while the tape is sufficiently moist to take a good hold; but with a little practice one can become most proficient.

Never spread the glue on the veneer, as to do so will destroy all the good effects of redrying. After the glue has been spread on the core it should be allowed to set for a few minutes to become slightly "tacky." This will allow some of the moisture to penetrate the core where it will be comparatively harmless; otherwise much of it will enter the veneer before it can be gotten under pressure. And let us say to get the stock under pressure at the earliest possible moment after the veneer touches the glue in order to prevent the veneer swelling through the absorption of moisture from the glue.

SPREAD THE
GLUE ON
THE CORE

And in this connection let us not confuse cause and effect. In removing moisture from veneer by the process known as redrying we have two objects in view. It is very seldom that veneer which has once been dried contains a sufficient amount of moisture to prove a detriment to the glue; hence the removal of the moisture is of secondary consideration. Moisture in veneer is a cause and not an effect. It is the cause of expansion in the veneer; and it is to decrease this expansion that we remove the moisture. If the veneer is laid in to this expanded condition and becomes firmly cemented to the core it cannot shrink back to its normal width during the process of drying the built-up stock—that is, it cannot draw in from the edges. The fibers themselves will shrink, and will separate one from the other, making very fine checks in some instances; and in others larger ones. It is to prevent this that we remove the moisture before laying the veneer when it

can shrink to a minimum width without injury to the fibers.

To prevent the veneer expanding through absorbing moisture from the glue we advise getting the stock under pressure as soon as possible after glue and veneer come together. There are many who have the idea that so long as the veneer was made thoroughly dry before being laid all danger along this line has passed; but a more fallacious idea could scarcely be entertained. It is at this point that the real danger exists. It is seldom that a veneer which has once been dried will contain as large a percentage of moisture before being laid as will be found in a redried veneer two minutes after it has come in contact with the glue. One should not lose sight of the fact: It makes no difference how, when or where the veneer gets the moisture that expands it—whether the dews of heaven descend upon it; whether it gets it from the atmosphere during a period of high humidity or gets it from the glue just prior to going under pressure, the effect is the same—expansion. And it makes no difference how, when or where this expansion was brought about, the effect is the same—contraction; and the inevitable result of the shrinking veneer after it is laid is: checks.

EXPANSION
AND
CONTRACTION

OPEN
JOINTS

Not a few people have trouble with butt joints opening after the veneer is laid. These openings are not always uniform; and they do not always extend the full length of the joint. This has frequently given rise to the suggestion that the man who jointed and taped the stock was careless about his work; and has frequently resulted in much confusion and no little ill feeling. But no matter how well stock may be jointed and taped it will open in certain places if allowed to absorb moisture from the glue before it receives the pressure.

Wood does not expand uniformly at all points. In the case of crotch veneer the difference in fiber and texture of the different figures allows great scope for this uneven swelling; and when those places along the edge of the joint which expand more rapidly than others, do so, and press against each other they sepa-

rate the slower swelling parts—hence the uneven, open joint.

The remedy for this is the same as for checks, i. e., get the pressure on before the veneer can swell, for under heavy pressure it cannot move.

In laying crotch veneer on ogee drawer fronts and other shaped work some have resorted to moistening the veneer with water to prevent breaking. This is all right as far as it goes; but it does not go far enough. Those who follow this practice admit they have plenty of trouble with the veneer checking; but they claim the checks are not as bad as would result from laying the veneer when dry; and of two evils they are choosing the least.

THE LESSER
OF TWO
EVILS

But there is no necessity for making a choice between these two evils; for both may easily be avoided. Make some forms—duplicates of the forms to be veneered; using basswood, or some other absorbing wood for the purpose; and heat them in the hot-box. Moisten the veneer with water to render it pliable; and when sufficiently so bend it to shape in the duplicate forms under pressure the same as when laying the veneer permanently. The usual amount of moisture in veneer thus treated will make it difficult for one form to insure its complete elimination. For this reason it would be well to either re-heat the forms and make a second application, or place the veneer in the drying room for a short time. It will retain its form, so that no trouble need be anticipated from that direction.

Where animal glue is used for veneer it is necessary to use warm (not hot) cauls, which help to keep the glue in a liquid state for a longer period of time than would otherwise be the case, enabling it to more firmly unite with the wood. Let us lay emphasis on the importance of the cauls being at the right temperature. The heat in the caul helps to diffuse the moisture in the glue; driving it into the core; and the hotter the caul the more rapidly it drives it away. This is as it should be, for in the core the moisture can do no harm. But if the caul is not hot this rapid diffusion of the moisture creates a source of danger, as it leaves the glue in a

USE
WARM
CAULS

CAULS SHOULD
NOT BE
TOO HOT

dry state devoid of the protection of the moisture, in which condition it is very easily injured by heat. This can be better understood when we remember that the heat required to prepare the glue for use would render it absolutely useless were it not for the protection furnished by the water which it contains. Cauls should never be made so hot that they cannot be readily handled with the bare hands, in which condition they can do no harm.

CHAPTER XXVI.

SPREADING THE GLUE

ONE cannot do good work with inferior glue, but he can do very poor work with the best glue if he does not use it right. The glue-mixer may have his solution in the best possible condition, but all his care will be for nought unless those who use it afterward understand what is required of them. "The chain is no stronger than its weakest link" is a maxim no more true anywhere than here. All through the process of building glued-up stock every detail requires intelligent and careful attention, otherwise there will be a weak link in the chain of operations because of some neglected detail and the work will fall down at that particular point.

The spread of glue must be uniform and of the correct weight. For this reason glue-spreading machines are preferable to the old-time brush and glue pot, as the spread is evenly placed all over each piece and each piece is spread alike. But the operator of the mechanical glue-spreader must understand the weight of spread required for the work in hand, otherwise the spread may be too heavy or too light and defective work will result.

GLUE SPREAD
MUST BE
EVEN

Much poor work results from a too heavy application of a heavy glue solution. It is obvious that an insufficient quantity of glue to the joint will result in defects sooner or later; but not every one can see that an over-application of glue is equally bad. If one puts on an excessive amount of glue of a heavy consistency and allows it to stand until it becomes tacky there is danger of the surplus not squeezing out, and thus leaving an excessive amount in the joint. Where this occurs, the glue, in shrinking during the process of drying, is much more liable to break away from the veneer, allowing the latter to raise in places in the form of blisters.

The modern mechanical glue-spreader has one seri-

INTELLIGENCE
IS NEEDED

ous defect—it has no brains; but I am sometimes inclined to think that it has about as much of that commodity as many men who are allowed to spread glue with a brush in some shops. Some employers appear to have the idea that the mechanical glue-spreader has brains of its own, and that a further supply is unnecessary, and they put a man in charge of the machine who gives no evidence of being in possession of that prime necessity.

From almost every viewpoint the mechanical glue-spreader is essential to the success of the veneering department; and especially is it an economic necessity. It will do more and better work than can be done at the same cost when done by hand; and it conserves glue, which is no inconsiderable item at the present time with the prevailing high prices. More glue than is necessary is not put on the stock; and the glue is not wasted by splashing everything around. In many plants the saving of glue through the prevention of waste alone would soon pay for the machine.

LOOK FOR
THE CAUSE OF
FOAM

In operating the mechanical glue-spreader one must give special attention to the speed, for if run too fast it will unduly agitate the glue and cause it to foam. If the glue should foam, suspend operations at once until the cause of the foaming has been ascertained. Some glue will foam much more readily than others for which there may be various causes. If the foaming continues under a reduced speed the cause will be in the glue; the thing then to do is to examine local conditions to ascertain if the cause of the trouble is in the shop or came with the glue.

If the glue is fresh and the dissolver was clean before the glue was mixed, and the spreader was thoroughly cleaned before it received the solution and the glue has not been overheated, then it is pretty safe to conclude that the cause is not local; but is inherent in the glue.

Some experiments have shown that glue foaming may be caused by the entire absence of grease from the glue. Good glue intended for brush work usually contains no grease, this having all been extracted dur-

ing the process of making. When such glue is intended for the spreader, and the manufacturer knows the purpose for which it is intended he will usually add a sufficient quantity of cocoanut oil to prevent foaming. A serious case of foaming has been checked by adding a piece of beef tallow the size of a marble to each gallon of the glue solution. This amount, though sufficient to prevent foaming, would have no appreciable effect on the adhesive quality of the glue.

There are other causes of foaming, but all point to inferiority in quality. Cheap bone glues are prone to foam when used in the spreader; and glue that has been over-limed will do likewise. Such glues should not be used where good work is expected to result.

GOOD WORK
REQUIRES
GOOD GLUE



CHAPTER XXVII.

THE GLUE SALESMAN.

SALESMANSHIP has been advanced to a science. It is no longer a wierd and mysterious magic by which one man influences another to buy from him an article which he may or may not want. It is no longer, as it was in the early ages, an exchange of necessary commodities. It is no longer a happy hunting ground for the shrewd and unscrupulous, but it has evolved from its first stages of necessary exchange, through all the mazes of charlatanry, bringing with it the best from each stage, until it has grown into a science and profession. Slower than the professions of the physician and chemist in its development, it has, however, reached a degree now, in which it is building its own etiquette and coming to its own recognition.

THE SCIENCE
OF SALES-
MANSHIP

In view of this modern science of salesmanship, I shall attempt to give my ideas of the scientific selling of glues.

It is very true that there are certain lines of business in which the salesman has no competition; this, however, is the exception. There are many lines in which the competition is more imaginary than real; that is to say, the quality of the goods of the so-called competitor is so much inferior to that of the goods carried by a first-rate manufacturer that there is no real competition. The buyer, however, who is usually shrewd, and, unfortunately is often unscrupulous, will, if possible, lead the salesman to think that competitors have given better prices or better terms, and that their goods are superior. The salesman who is not armed at every point to meet his tactics runs the risk of being imposed upon.

We know absolutely that most manufacturers, jobbers and dealers of glues desire to please the customer and will endeavor in every way to hold up the grade that is being bought. These men know absolutely that many buyers will try to buy glues at low prices and

THE CUSTOMER
MUST BE
PLEASED

**SALESMEN
MUST KNOW
THE GAME**

some buyers may "bluff" the salesman. In most cases it has been due to the salesman's ignorance that the sale was lost. Again, nothing will destroy a buyer's confidence more quickly than to find a salesman ignorant of the claims made by his own house, or of the specific qualities of the glues offered for sale. All salesmen need to keep themselves fresh and enthusiastic in regard to their goods, not only by frequently visiting their factories, keeping in touch with the qualities of all boilings, but also by reading all literature applicable to glue and glue testing. Therefore, do not superficially peruse the pages of this valuable book. Read all the material contained herein time and again and the writer knows absolutely that if the information is applied, the salesman's success is assured.

Get all the information you can from the salesmen of competing factories. Learn all you can in an open fair way, but do not resort to trickery, or to any methods which you would be unwilling to have a competitor use with your house. Do not attempt to sell goods until you know absolutely that you can meet any argument and that your line of talk is of such character that there will be no doubt in the mind of the buyer that you are not a novice, not a traveling man trying to put something over, but a real glue salesman in all that the name implies.

**DON'T KNOCK
THE OTHER
FELLOW'S
GOODS**

It is to be regretted that there actually are glue salesmen who seem to delight in "knocking their competitors." I have met men who deliberately knocked high grade glues, comparing them in quality with low grade products. A certain salesman sold hundreds of tons of grade 1 $\frac{1}{4}$ glue for joint purposes and claimed his glue would compare with any joint glue regardless of price. His argument was that his glue did not take as much water as most hide glues, but it is of the highest quality as a joint product. Very fortunately the writer made joint determinations in the presence of the salesman and his glue was used in the test. This man has not called at my office since and he did finally say: "It takes a salesman to get by with my line of 'stuff,' but the man selling high grade glues at a reas-

onable or low price is not a salesman but an order taker."

So many salesmen seem to suppose that business is done largely on friendship. "Friendship and business don't mix," is an old adage and a true one. You can't presume on your intimacy with a man to sell him goods; and it is seldom you can get his trade away from a successful salesman, even if you have identical grades and quote the same prices. There is no doubt that business friendship plays a very large part in business getting with all salesmen. You know how hard it often is to break in on the trade of another man, simply because he has won the friendship of his customers. Keep this in mind, but please remember that if your goods are right and the price reasonable, you have nothing to fear, especially so if you merit the confidence of your trade. I have known of buyers purchasing glues from one factory for more than thirty years. They finally came to their senses though and now every reputable glue house known to them gets a chance at their business.

DON'T PRESUME
TOO MUCH ON
FRIENDSHIP

To be a successful glue salesman it is absolutely essential to become familiar with practically all the different lines employing glues or other adhesives in their work. For instance, in selling glues to manufacturers of wall paper it is necessary to offer only such glues as are free from foam. The glue must also be free from mucin and soaps which will not affiliate with the colors or clay. He will not offer glues to textile manufacturers containing mineral acids and normal sulphites since any notable proportions of these impurities will reproduce light patches on dyed wool. He is also very careful in offering glues free from coloring agents that will injure the shades of silks. He knows that pale glues have been bleached with sulphuric acid, traces, and frequently more than traces of which remain in the glue, as well as salts of sulphurous acid. When selling to manufacturers of paper boxes, the salesman appreciates that either animal or the vegetable glues may be used to good advantage. He knows that where gloss or the finish of a good covering paper has to be

**MANY USES
FOR GLUE**

preserved, the animal glue has preference. When asked why he will say, because the pastes, and some gums have so much water in them that the gloss is impaired. He also knows that the drawbacks of animal glues are higher prices and that in this respect the vegetable glues have the advantage. Mr. Glue Salesman does not lose sight of the fact that various box factories offer different problems and every problem deserves study and well "thought out" solutions. Indeed, there is hardly an article manufactured in the making of which glue does not play a very important part in some form or other.

The salesman should, if possible, be practical. Some of the things that the salesman can do along this line are trivial. Some, on the other hand, are big. The representative who can give the men in the glue room valuable tips, is always welcome and the superintendent or foreman may ask the purchaser of glues from time to time, "When is So and So coming? That fellow understands his business and I would like to have him assist me in solving a very perplexing glue problem." Truly, the salesman who can do these things is tying his customers to him with ropes of steel and will make his visits an event instead of a call.

**THE SALESMAN
SHOULD MAKE
SIMPLE TESTS**

When visiting a project endeavor in every way to obtain samples of the glues he is using and mail these promptly to your factory laboratories for analysis. The factory manager should insist upon having samples tested on the same day they arrive, or as soon thereafter as possible. In the event of a big contract being at stake and there being a likelihood of the contract being signed within a very few days, the salesman should do the testing at the prospective place of business. Should this be impossible, make a few important tests at the hotel. I would suggest the carrying of a viscosimeter, balance, litmus papers and a few beakers. The jelly can in such extreme cases be tested by what is known as the "finger test" fully explained in other pages of this book. A suitable thermometer can be carried in the vest pocket, in fact, it is as necessary for a good glue salesman to carry such an instrument

as it is for the physician. Stick (as you would have your glue do) until you have closed the deal. Remember, you are in a sticky line so never say "quit."

If you want to reach the high mark in the selling of glue, you have to have overwhelming belief in yourself and not only in the glues you sell, but in the house that manufactures them, and you must believe in yourself first of all. Extravagant hope and confidence are necessary. This is one place where extravagance is an asset.

Enthusiasm is the great, far-reaching wisdom of faith—it prompts and sustains the noblest efforts. If you have it you should be thankful and if you have the brand that is contagious, you are a public benefactor and a record-breaker so far as sales go. Never, *Never*, NEVER! show a weakness in your argument or general sales talk, for this will be detected and like enthusiasm, is contagious. Do not, because a man buys tons of glue every year, be afraid of him and feel more at home in the small hardware store selling probably twenty-five pounds annually. Your prospects must never be approached with timidity, an "excuse-me-for-living" attitude. You are or should be just as good a man as the purchasing agent.

ENTHUSIASM

One grave mistake I find so many salesman make, especially men representing very large glue factories, is to "jump towns" and call up over long distance telephone from some neighboring city and say in a seemingly bored way: "Went through your town this afternoon, but really it does not pay me to stop off in small cities, for you know I'm representing a very large glue house and we must keep moving. Anything doing in the glue line today?" Such men are not salesmen, but may be classed as mere order takers. Of course, it may at times be necessary to resort to the telephone, but do not do so unless it is absolutely necessary and you are very well acquainted with the purchaser, knowing that he will not be offended.

ORDER TAKERS

Don't ignore questions about competitors, and don't fail to banish from the customer's mind all doubts and prejudices, but it is a serious mistake to spend a lot of

COMPETITORS

time talking about competitors' glues when you ought to be sticking to the merits of your own. Answer quickly all questions, and then switch back to the excellence of your product. Be so enthusiastic about your own selling points that rivalry will be forgotten. In meeting competition, do not be fooled by the question of price. At present, very many lines are of practically the same quality, grades considered, and prices are about the same, so that you must bring out, as a high grade salesman should, the fact that service is the main consideration. Show what your house can do in the matter of prompt deliveries, careful packing of glues, dependability as regards uniform quality, correct weight, liberal terms, etc., and do not forget that the general reputation of your house is a selling point. The facilities which you have for keeping abreast with the times, like the employing of expert chemists and engineers in your laboratories to do your experimental and research work, thereby improving the quality of your glues all the time, is a point of service well worth consideration.

SERVICE

STRONG
PERSONALITY

Above all, a glue salesman can meet competition most effectively by a strong personality. Remember that your glues are judged by yourself, sometimes even unfairly; and remember that we are always judged by our weakest points; hence, in order to hold your trade from competitors, and to get new trade, you must possess what is commonly called "business magnetism," which is another way of saying a strong personality.

THE DUDE

A salesman called at my office a few years ago clad in a "Prince Albert" coat, very delicate kid gloves, a silk hat, highly polished patent leather shoes, a white tie, a large diamond stud and his fingers were decorated with diamond rings. The gentleman had the appearance of a nobleman and when he handed me his card which stated that he represented a glue manufacturing concern, I was astonished. I noticed that it seemed to actually be impossible for the gentleman to talk because of a very high starched collar he was wearing. It occurred to me that it would be cruel to expect my

new acquaintance to say anything and it did seem that the subject of glue must be distasteful, so I politely informed his excellency that we are not considering new glues. I kept his card, however, and received samples from time to time, but the prices were so high as to be prohibitive. It evidently cost this concern money to keep the dude on the road.

Another instance was that of an apparently intelligent young man representing a prominent glue house, who came to my office in an intoxicated condition. He fairly staggered to my desk and immediately after introducing himself said to me in what was to be an undertone, that he spent the night in Toledo and had a h— of a time. Did he get an order?

THE "SPORT"

Again, we meet the type of salesman who knows all about glues. He's the "candy salesman." No one has anything on him. He can determine glue quality by taking the lid off the barrel and smelling of the glue, or, by looking through the flake he can tell the grade. "Them there new glue testing methods ain't no good." Mr. Wise doesn't care what tests show, he'll tell you that it takes an expert like himself to select glues, leave it to him, he'll supply the right kind of stuff and save you money.

THE "EXPERT"

The writer met a glue salesman a short time ago, who complained very bitterly about not being appreciated and the low salary his employers are paying for his services. I told him that I was sorry because he imagined his employers were trying to keep him down; that I know the concern very well and that I did not believe them to be business men of that sort. I asked whether he ever thought of how much money he was making for his employers? Did he make many mistakes and get the concern into trouble because in some cases he may be overly anxious and make statements that cannot be fulfilled? Did he spend his leisure time in studying glue problems and was he familiar with the testing of glues, abuses, etc.? He thought a few minutes, then replied, "Guess you are right, have never thought of my position just that way." I hope the young man in question reads this book and especially

THE "CRAB"

this paragraph. He is invited to write to me and to state whether my suggestions have proven of benefit to him, providing, of course, he has followed them.

Glue manufacturers are largely to blame for selecting some men to sell glues who are no more fitted for this vocation or profession than is the writer to drive an airplane. Indeed, of all the elements which go to make up a successful glue business, that of salesmanship is most frequently neglected. Business is a profession and a science. Salesmanship, which is a direct representation and most important factor in business, is the greatest of all professions, and is likewise a science. If some of you glue manufacturers, jobbers and dealers could watch some of the representatives I have met trying to sell glue, you would be tempted to boot them out of the office. Do not in the name of common sense regard salesmen as necessary evils. Train them and do not permit any one of them to present your cards to the trade nor announce their connection with your concern until you have every reason not to be ashamed of them.

Instruct your salesmen to base their selling campaign on the objections that are sure to be raised. No salesman should ever start out without first having satisfactorily answered every conceivable objection from every point of view.

It is singular, indeed, to observe so few advertisements from glue manufacturers. Some will tell you that the reason they do not advertise is because they employ salesmen whose business it is to call on prospectives and customers, show samples of glues and discuss their merits. The glue manufacturer seems to forget that through the advertisement published in good, live trade journals he will reach thousands of glue users at nearly the same time and the salesman can call on but one person at a time. It is, of course, true that the advertisement may not always complete a sale, but it will certainly pave the way for future business, for it will impress the name or an attractive quality so that the reader will think of your concern when in the market for glues. A good ad will invariably influence the reader in favor of your commodity.

TRAIN YOUR
SALESMEN

REGARDING
ADVERTISING

The writer has heard glue makers say: "Why should I advertise? Supposing I list grades of glues based on Peter Cooper standards; I name prices and some competitor will answer my ad stating that he is prepared to offer lower prices. He will not furnish the same grades, but too few glue users test glues and would be unable to tell the difference, so I lose out because of being honest and the trickster gets the business." The writer must admit that this has been true, but we must also remember that we are all doing business differently than we did five or ten years ago. Where such a condition exists it is the best kind of advertising to show up the cheater and by so doing the glue buyer will be your friend for life.

Many glue manufacturers are doing a great deal of effective advertising by means of form letters, which are printed in imitation of typewriting. Indeed, some of the very best form letters I have ever perused were written by some genius who certainly understood the requirements of glue users and his letters without a doubt "brought home the bacon." At the present time printing offices in nearly all of the large cities can furnish form letters from typewriter type that are good imitations of typewriting. Good matching is very important in inserting names, addresses, and other matter in form letters.

FORM
LETTERS

Glue advertisers can sometimes afford to distribute novelties that will keep their names before the public. I often wondered why manufacturers do not prepare printed tables for the glue buyer showing viscosity test, jelly, etc. It would certainly be splendid to prepare tables from different strength solutions run through various viscosimeters, especially the viscosimeter having various sized apertures. Again, inexpensive thermometers for the glue room would be appreciated. These novelties would likely not bring direct sales, but would support other advertisements together with the work done by your salesmen. Your novelty should be a constant reminder of your business and should be of such value so it will not be destroyed.



CHAPTER XXVIII.

BUYING AND SELLING GLUE.

THE functions of every purchasing department in a manufacturing establishment are: First—To secure the most satisfactory material required in the manufacturing processes. Second—To secure the most desirable delivery of the material, keeping complete and accurate record of all unfilled purchase orders.

DUTIES OF
PURCHASING
DEPARTMENT

Third—To obtain the best terms of payment and the lowest prices, quality considered.

Fourth—To record and classify materials and supplies used and purchases made.

Fifth—The buyer should have complete lists of all manufacturers of glues and other adhesives. He should keep in touch with these concerns and though he cannot buy from all, and, would possibly buy but from one or two, nevertheless, it is well to receive quotations and samples for comparison.

The successful accomplishment of the first function demands that the glue buyer shall be a man who has a working knowledge of the particular industry for which he is buying this class of material. If he has in addition acquired the knowledge of glue testing, so much the better, for he will be able to make practical application of such knowledge.

If care is exercised to obtain a man of the qualifications indicated to purchase glue, there will be far less liability to make the error so frequently made, of buying grades of glues good enough in themselves, but not exactly adapted to the particular purpose for which the glue is desired.

The second function applies largely to the traffic department, or, in small plants proper routing should be specified by the glue buyer. Again, it is usually important to ascertain at the time of purchasing the age of the glue and the possible date of shipment.

To obtain the lowest price does not mean "cheap

SUBSTITUTING
PRICE FOR
QUALITY

glue." It is to be regretted that in too many cases glue is considered as just *glue*. Some salesmen fear competition and have no desire to enlighten the glue buyer as to glue standardizing. The tendency, therefore, is for the salesman to say that his glue is as good or stronger than the one the buyer is using, that it takes more water and as a natural consequence is a cheaper product so far as glue economy is concerned. The salesman may make price the predominating element, to substitute salesmanship for science. High grade glue costs money and no manufacturer can afford to sell an article for fifty cents that possibly costs him one dollar to produce in his factory. Nevertheless, prices may be unreasonably higher and the buyer should possess the ability to determine the lowest just and fair price, the quality of the material considered.

TRAY CARDS

It is well to list manufacturers, jobbers and dealers selling glue on suitable tray cards. The card should give the name of the manufacturer, jobber or dealer, address, grades of glues manufactured, financial rating (the financial rating being a fairly good barometer to show whether or not the manufacturer, jobber or dealer is financially able to carry out the terms of the order of contract.) The card should also show the kind of glue manufactured, hide, bone, vegetable, waterproof or any other adhesive. The buyer should ascertain, if possible, what grades of glues the manufacturer, jobber or dealer specializes in. The manufacturer of paper boxes would likely not be interested in high grade hide glues and the wood worker would not find the box-maker's glue practical in his line of work; therefore, it would not be advisable to list all grades of glues and the manufacturers, jobbers or dealers handling the grades and kind of glues you do not require.

The back of this card may be arranged in columns for the purpose of entering quotations. The first column would show the date, the second manufacturer's or jobber's number of the glue boiling; the third, grade of glue; fourth, the number of unsold pounds in the boiling; fifth, F. O. B. point; sixth, price; seventh, terms. Ordered columns may also be provided on the

back side of the card. First column showing the date and second, quantity ordered.

The glue buyer must insist upon receiving timely requisitions from all the departments requiring glue. Under ordinary circumstances the purchaser of glues should place no orders until he has first received a requisition from either the stores department or the department that requires material.

REQUISITIONS
REQUIRED

A positive rule should be laid down that all glue requirements be anticipated in ample time so that the buyer will not be compelled to purchase unsatisfactory stock from possibly a nearby dealer so as to avoid a "shut-down." Again, requisitions should be signed or countersigned by either the foreman requiring the material or the superintendent. Requisitions can, of course, be drafted to meet individual requirements.

When contracts are made involving a large investment, considerable testing and investigating will be necessary and the writer's experience has been that it will require from thirty to sixty days to get samples, test them, receive quotations and finally decide upon the glue that will be contracted for.

Departments requiring glue or store rooms should carry what may be termed a "Low Stock Report." The glue should be given a low limit and when this is reached the workmen, foreman, stores-keeper or whoever has charge of the glue should report promptly to the person issuing the requisitions.

It is also imperative to keep a complete record of all tests and to file them for future reference. A vertical two-drawer bill file cabinet answers this purpose very nicely. In the top drawer file favorable reports. In the second drawer the unfavorable. The advantage of this scheme is apparent, for it is a simple matter to determine within a few moments who supplied the best and who the poorest samples. All test cards, good or poor, should be filed. I have found this scheme especially valuable in calling the bluffs of glue salesmen who persist in knocking their competitors' glues.

KEEP ▲
RECORD OF
TESTS

The manufacturer spending money in the way of the salesman's salary, railroad and hotel expenses de-

GIVE THE
SALESMAN
A CHANCE

serves consideration. It is to be regretted that many glue buyers do not appreciate this and in many cases glue salesmen representing the most successful and reliable glue houses are turned down—not even given an audience. When a salesman spends time and money to visit you, he has something to say and if you are a good buyer you will permit him to have his say. To be sure there are many men who suppose the buyer has no other duties than to listen to stories, smoke cigars, and be a good fellow. The writer usually allowed every salesman from five to ten minutes and he was given to understand when entered my office that he must be brief.

Another suggestion: Whenever you find a boiling that is highly satisfactory, buy the entire boiling. Of course, the writer appreciates that small manufacturing plants cannot at all times avail themselves of such offerings, however, the glue manufacturer may reserve a certain quantity or possibly all of the boiling for the small manufacturer, especially so if a reasonable deposit is made or a liberal amount taken in on the first shipment. When buying the entire boiling you know absolutely just what you are receiving. The writer has never regretted doing this.

If the buyer of glues will avail himself of the information given he will avoid excessive buying, inferior quality, high prices and poor deliveries. Right buying means an improvement in the quality of the goods, increased production, and, last but by no means least, satisfied customers.

CHAPTER XXIX.

PAPER BOX ADHESIVES.

THE average paper box manufacturer buys very cheap glue. This is usually a bone product of the lowest grade. It is possible to use almost any kind of glue in the manufacture of paper boxes and the real factor is the price. It is, of course, imperative to select glues that are not in the stages of decomposition and the tests explained in this book, when properly applied, are all the information that is required to determine this point. Again, in boxes that are printed or colored it is necessary to avoid glues that are too strongly alkali or acid. The litmus tests explained for acidity or alkalinity must be applied. If the paper box maker will study all the information explained in the pages of this treatise he will eliminate all of his glue troubles. It will be appreciated that it takes but little glue room abuse to almost destroy the adhesiveness of a cheap or low grade glue. Watch the temperature. When heated, all glues are gradually killed and the damaging action begins as soon as the temperature of the solution reaches 120 degrees. Unfortunately a slightly higher temperature than the temperature at which damage to glue begins is quite necessary, nevertheless, common sense must enter into the problem and if the paper box makers will exercise great care they can obtain a higher degree of efficiency and in many cases greatly improve the quality of their product.

SELECTION OF
GLUE FOR
PAPER BOXES

The novice will be surprised to observe the possibilities of box making machines. There are a number of popular machines; we will, however, discuss the merits of but three.

BOX MAKING
MACHINES

The Jagenbry Box Making Machine automatically feeds the cut out blanks, forms the box, glues, applies, cuts strip paper and turns striper in and over.

The Staude Automatic Folding Box Gluer will automatically feed blanks one at a time at a high speed,

glue, fold, count and stack in a vertical pile that keeps the glued seam under pressure so it cannot pop open.

There is a possibility of combining vegetable and mineral adhesives such as starch solutions and flour pastes and silicate of soda. The essential requirements would here be that the vegetable part should not contain any considerable excess of free alkali.

ESSENTIAL
REQUIREMENTS

Most box makers have their own private formulas. One of the points to remember when working out a formula for a paper box adhesive is the setting of the glue. Of course, we know that the lower the temperature in the work-room the lower the temperature of the warm liquid glue, and the higher the grade of the glue, the quicker will the glue set.

For the building of chip or container board silicate of soda is used. The stock is built up the same as plywood. The only pressure applied, however, is on the machine when the stock goes through the squeeze rolls. Silicate of soda has much less water in it than is used with other adhesives and the various grades are produced with considerable latitude in setting.

SILICATE OF
SODA

It requires from fifteen to twenty pounds of silicate to build up 1,000 square feet of three-ply board, 15 pounds as minimum and 20 pounds as maximum. It varies between these two points on different grades of paper. Each additional ply will require from $7\frac{1}{2}$ to 10 pounds additional silicate of soda. A three-ply board has two pasted sides. A four-ply board has three pasted sides, each side requiring $7\frac{1}{2}$ to 10 pounds of silicate of soda per 1,000 square feet irrespective of caliper of the board.

Silicate of soda is packed in either wooden barrels or metal drums, both containing approximately 600 lbs. The barrels have two openings, one in the center and one in the head, and the silicate can be drawn from the same with a good sized spigot, say one inch inside opening. The user should always draw from the barrel in a small container the desired amount for one day's use, and when the brush is not in use the bristles should be submerged in water, which will preserve them.

CHAPTER XXX.

AVOID ABUSES.

EVERY office and department in any manufacturing plant requires system and organization. When these important factors are neglected the quality of the goods is certainly compelled to suffer and the manufacturer usually realizes a loss instead of a gain. No manufacturer is in business for his health. He cannot "break even" year after year and he is either making or losing money. The woodworking manufacturer knows that it costs money to repair open joints or blistered and loose veneers. It isn't always the fault of the glue, as has been generally charged, and I know from experience that in most cases the workmen or the system are at fault. Our first duty is to select the grade or grades of glue that will give *reliable* results. When selecting glue for wood work we must insist upon receiving the purest glue available, glue that is not loaded with chemicals to give fictitious value. The writer has already explained the requirements of various lines and we will not here repeat anything that has been stated.

BUY GOOD
GLUE

It is immaterial whether we manufacture matches, emery wheels, cloth, paper boxes, furniture, caskets, pianos, etc. We are all interested in *glue that holds*. It is an absolute fact though that different workmen may get different results with the same glue all made in one boiling at the glue factory. Why such differences? The answer is simply, that every one of the men may abuse the glue, one more than the other and when used the quality is not the same high grade as when originally dropped in the glue cooker.

RESULTS
VARY

The one feature that is an absolute essential to the proper working or handling of glue is intelligence. We want to forget that any Tom, Dick or Harry can prepare glues, and all you need give him is a few pails, a quantity of glue and show him where the faucet is so that he can prepare the glue for "soaking." We must

LET YOUR
MEN READ
THE BOOK

train our men, and to do so every manufacturer, large or small, can well afford to place our glue books in the various departments so that the workmen can learn how glue should be prepared and properly handled to get 100% efficiency. The workmen who master all this book contains may rightly call themselves experts, and if this is done the manufacturer will then have the assurance that glue room troubles are a thing of the past. I did not incorporate this statement to boost the sale of the book, but this is absolute truth and the writer has in mind only the welfare of his readers.

Practically every department in a manufacturing plant has one or more foremen. These men are singled out to oversee the work. This should also be done in the glue room. Single out the most intelligent man you have in that department and hold him responsible. This need not be the foremen for the reason that these men have too many details and they likely cannot give the preparation, distribution and using of the glues the close and careful attention so necessary if quality is to be realized.

GLUE ROOM
TEMPERATURE

Proper equipment is very necessary. We are going to discuss equipment in another chapter so will next direct your attention to the temperature of the glue room. We all know how imperative it is to have a fairly uniform temperature in varnish rooms. Your glue room is just as important. Again, you avoid draft in the varnish room and we must do so in the glue room. Chilled glue will cause trouble and when the stock is, too hot, owing to a very high temperature in the gluing department, the men are uncomfortable. Some men insist upon heating the wood until so hot that one cannot touch the heated surface with the naked hand. When wood is heated hot, too much glue is taken up. Then when the wood cools off the air in the pores beneath the glue contracts as it cools, creating a suction which draws the glue farther into the wood, and this is liable to seriously affect the joint for there may be a little glue left on the surface, as it is all absorbed by the wood.

Having the ideal glue room conditions and the most

suited stock for our peculiar requirements, we must measure the glue and water. Hundreds of manufacturers in all lines of business neglect doing this and the men pour water on the dry glue until the surface has been covered. *Weigh your water as well as the glue* and watch the proportions very carefully.

GLUE AND
WATER MUST
BE WEIGHED

The function of soaking is to get back into the glue the liquid it originally contained. Precautions must be observed that will insure uniform softening prior to melting. Very frequently one finds long or wide flakes. It is well to break them into suitable sizes prior to soaking. Do not permit pieces to stick out of the water. All of the glue must soak and unless this is the case it will take a considerably longer time to melt than if soaked properly before applying heat. Many so-called "glue experts" object to soaking the glue over night. This is perfectly right in the case of flake glues, providing, of course, the room is not too hot. Hot summer nights are not very desirable. Glues should not be soaked too long as too much soaking kills the strength. Thin cut, high-test glues absorb water rapidly. They will therefore soak in a much shorter time than thick glues. This applies as well to ground glues. A very good plan is to pour water (taken from the quantity weighed) into the soaking container so that when adding the glue it will surely become soaked. Unless this is done you are taking chances and there may be particles or flakes at the bottom that will not become saturated. Stir again and again. This will assist very much and will to some extent shorten the time of the soaking.

Use only pure, cold water. Some men seem to be under the impression that there is no better water than that which has been chemically treated in the boiler for the prevention of scale. The writer at one time visited a woodworking plant having considerable trouble with glue. The grade was splendid, the men did not appear to overheat it and the entire problem had me guessing until I saw a workman coming up the stairs with two pails of water. I immediately became suspicious, and asked him for what purpose he

DO NOT USE
BOILER
WATER

intended the water. He replied, to soak the glue. I said, "Haven't you water faucets in your glue room?" He replied, "The clearest water we can possibly get is water that has been softened and this comes from the boiler." Here was the answer.

Again, I observed men drawing water from the water jacket in the glue cooker. This sort of thing is inexcusable and should not be tolerated in any glue room.

CORRECT HEAT

We have perused hundreds of articles in trade papers dealing with the subject of overheating glues. Every salesman cautions us against this evil. We feel, therefore, that little information is necessary along this line. However, for the benefit of any reader who may not know what damaging effects heat has on glue, I want to state that the most desirable temperature to heat glue is approximately 148 degrees F. For some classes of work from 138 up to 145 is perfectly safe.

The moment a mixture of glue and water is heated enough to melt it a gradual change begins to take place in such a way that the water-taking or spreading capacity of the glue is gradually destroyed. It is caused by the water attacking the glue and heat increasing the effect of the attack.

GLUE ROOM
EQUIPMENT

Heat should be applied indirectly. That is, do not permit steam to come in direct contact with the glue. Open iron kettles should never be employed. Of course, there is always more or less evaporation in glues. However, if the cookers or glue pots are closed this evaporation would, to a great extent, be eliminated. The construction of the glue cookers, pots, tanks, etc., is therefore of great importance. Our grandfathers would work with open iron kettles. Shavings, sawdust and foreign matter would be conspicuous in the glue pots. Therefore, they found it necessary to add more dowels or drive more nails to assist the glue in holding than is necessary today. We could, of course, go into details regarding cookers. However, there are a number of very good dissolvers or commonly called "glue cookers," on the market and every manufacturer makes certain claims for his product. The writer suggests

though that the buyer be very careful and that he buy only such glue room equipment as will give lasting results.

The equipment being right, there should be no trouble upon obtaining a uniform melt at the minimum temperature.

You would not think of operating your boilers without water and steam gauges. Therefore, it is imperative that you provide thermometers to your cookers, glue pots and glue spreaders. The automatic temperature controller is a wonderful appliance and by its use the supply of heat is automatically regulated.

When melting do so slowly. Every experienced glue user knows that there is nothing to be gained by attempting to dissolve the glue within a few minutes and that when this is attempted a scum is formed over the glue, preventing its proper melting.

**MELT GLUE
SLOWLY**

It is well to prepare two or three batches a day or more if necessary. Do not prepare so great a quantity that enough glue is dissolved to last three or four days. A glue solution when allowed to cool and then is remelted has not the same tenacity as a freshly prepared solution. Consequently, for ordinary work, the quantity of glue solution prepared should not be more than is required for immediate use.

The melting pots should be kept perfectly clean. Much unnecessary waste may be avoided through observance of cleanliness. After the melted glue becomes sour, and, unless this sour glue has been removed from the melting pot it will spoil the fresh solution. Do not, therefore, tolerate dirty pots and do not, under any circumstances, mix or permit a mixture of old dissolved and new glue.

Again, do not permit glue to freeze. If glue jelly is frozen through it will crumble and act about like over-heated glue.

**DO NOT ALLOW
IT TO FREEZE**

Do not use the glue until it has thoroughly melted. So many glue users seem to labor under the impression that partly dissolved glue can be used with perfect safety. This is wrong and should not be put into practice.

Do not permit the temperature of the glue to raise or lower. Keep it uniform.

Store glue in a dry place and do not unhead the barrels until you are ready to use the glue.

Co-operation is absolutely necessary in every line of business, and in every department. Your men will be glad to co-operate if given a chance. Having perfected your organization so that you know absolutely that you are receiving 100% glue room efficiency, do not forget the men who are assisting you in making this possible, and, the men who are actually doing the work. When your men are doing good work, be big enough to go to them and tell them so. This requires a little giving on the part of the employer, superintendent or foreman, but it is no expense—it is merely the giving of credit where it is due. As your men improve in your service their incomes should improve. The pay envelope and the occasional word of commendation are powerful tools that you have at your command for a persistent sequence of growth toward a better business.

CO-OPERATE
WITH YOUR
MEN

MEMORANDA

MEMORANDA

MEMORANDA

MEMORANDA

MEMORANDA

MEMORANDA

