



*Essentials of*  
AERIAL SURVEYING  
AND  
PHOTO INTERPRETATION

BY  
TALBERT ABRAMS  
*President, Abrams School of Aerial Surveying and Photo Interpretation*

FIRST EDITION  
FOURTH IMPRESSION

McGRAW-HILL BOOK COMPANY, Inc.

ESSENTIALS OF AERIAL SURVEYING AND PHOTO INTERPRETATION

COPYRIGHT, 1914, BY THE  
MCGRAW-HILL BOOK COMPANY, INC.

---

PRINTED IN THE UNITED STATES OF AMERICA

*All rights reserved. This book, or  
parts thereof, may not be reproduced  
in any form without permission of  
the publishers.*

*To*  
THE ARMED FORCES OF  
THE UNITED NATIONS



## PREFACE

This book combines the knowledge and experience of the members of the instructional staff of the Abrams School of Aerial Surveying and Photo Interpretation. In similar form, the material has been used in instructing men in the U.S. Marine Corps; The Engineering, Science, Management, and War Training courses sponsored by the U.S. Department of Education; and staffs of various schools and colleges.

Aerial photographic mapping and reconnaissance has become a very important weapon in the Second World War. It furnishes a fast and easy means of obtaining military information concerning enemy movements and methods of attack. Approximately ninety per cent of military intelligence comes from this one source alone. Recognition of the value of aerial photographs for mapping purposes and as a source of detailed information has developed a need for specialists trained in photographic interpretation and qualified to make detailed reports on topographic information in map and chart form.

This book is prepared to describe instructively present-day methods of aerial photographic interpretation and map making and the operation of modern photogrammetric equipment. It is intended to present the subject matter in its simplest and most useful form so that all can readily understand the many uses and applications of aerial photographs. Long mathematical illustrations have been reduced to simple and practical problems in arithmetic.

Chapters, as well as the material in them, have been arranged in the order of difficulty in a modern handbook-textbook style. This enables the reader to understand or to refer to the elementary uses of aerial photographs before attempting the more advanced uses. This arrangement will teach the "how" of aerial mapping.

Much credit for this book is due officers and enlisted men in our armed forces. They have supplied many fine suggestions and inspirations. For their help and the fine cooperation of all the graduates of the Abrams School of Aerial Surveying and Photo

Interpretation, the members of the executive and instructional staff wish to extend their most sincere thanks and best wishes.

The following members of the Staff of Instruction of the Abrams School of Aerial Surveying and Photo Interpretation contributed to the development of this book: H. L. Abrahamse, D. W. Cuckler, W. S. Karr, E. K. Kerkela, D. J. Hall, R. W. Hubbard, J. E. Meyer, R. W. Sharp, K. A. Smith, A. M. Villiard, A. F. Warren.

TALBERT ABRAMS.

LANSING, MICH.,  
*June, 1944.*

# CONTENTS

	PAGE
PREFACE . . . . .	vii
CHAPTER	
I. MATHEMATICS, SIMPLIFIED AND ABBREVIATED . . . . .	1
Slide Rule, Ratio and Proportion, Logarithms, Trigonometry.	
II. SURVEYING . . . . .	17
Introduction, Measurement of Distances, Measurement of Direction, Levels and Leveling, Plane Table Method, The Sketch Board, Triangulation.	
III. MAPS AND GLOBES. . . . .	55
IV. MAP PROJECTIONS . . . . .	58
V. ORIENTATION AND LOCATION. . . . .	69
VI. TOPOGRAPHIC DRAFTING . . . . .	83
Drawing Instruments, Topographic Symbols, Contours, Hasty Maps and Overlays.	
VII. HOW AERIAL PHOTOGRAPHS ARE MADE. . . . .	99
Aerial Equipment, How to Find the Scale of Prints, Vertical Photography, Oblique Photography, Laboratory Procedure.	
VIII. STEREOVISION . . . . .	127
IX. INTERPRETATION. . . . .	134
X. GROUND FORM LINES. . . . .	153
XI. STEREOPLOTTING INSTRUMENTS. . . . .	159
Abrams Contour Finder, How to Operate the Multiplex Aeroprojector.	
XII. TOPOGRAPHIC RELIEF MODELS. . . . .	186
XIII. RESTITUTION AND RECTIFICATION OF AERIAL PHOTOGRAPHS. . . . .	196
XIV. TEMPLATE METHODS OF RADIAL LINE CONTROL . . . . .	204
How Celluloid Templates Are Made, How Slotted Templates Are Made, How Mechanical Triangulators Are Used.	
XV. HOW TO MAKE A MOSAIC FROM AERIAL PHOTOGRAPHS . . . . .	225
XVI. THE TRI-METROGON SYSTEM OF WORLD CHARTING . . . . .	241
Rectoblique Plotter, Lazy Daisy Mechanical Triangulator, Vertical Sketchmaster, Oblique Sketchmaster, How the Instruments Are Used.	
GLOSSARY . . . . .	263
BIBLIOGRAPHY. . . . .	281
INDEX . . . . .	283





# ESSENTIALS OF AERIAL SURVEYING AND PHOTO INTERPRETATION

## CHAPTER I

### MATHEMATICS—SIMPLIFIED AND ABBREVIATED

#### THE SLIDE RULE

The slide rule is based upon a logarithmic scale. This makes it possible to do on the slide rule all the arithmetic operations that can be done with logarithms. The operations we shall consider

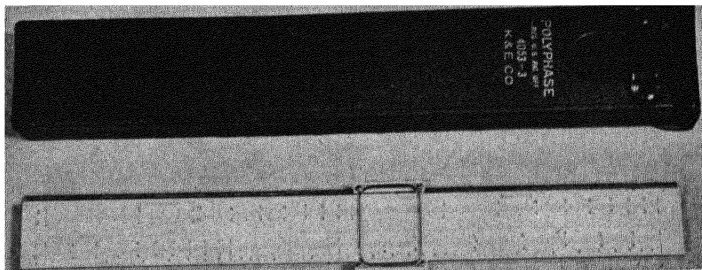

FIG. 1.—Slide rule and case.

are multiplication, division, powers and roots, and combinations of these.

The accuracy of the slide rule is to three significant figures, *i.e.*, three numbers regardless of the decimal point. Sometimes this is accurate enough for aerial survey work, but usually the slide rule is used for a check.

**Reading the Slide Rule.**—The slide rule has on it a number of different scales, each of which has a definite function. The number of scales on a rule depends upon the manufacturer, the simpler ones having 4 scales, the others having up to 18. The scales to be considered here are the ones lettered *A*, *B*, *C*, and *D*.

The *C* and *D* scales are first divided into 10 units that are labeled 1, 2, 3, 4, 5, 6, 7, 8, 9, 1 and extend the entire length of the rule.

## 2 AERIAL SURVEYING AND PHOTO INTERPRETATION

These divisions represent the first digit in the number. The distances between these numbers vary and are divided into smaller units.

Between 1 and 2 are smaller numbers 1 to 9, which represent the second digits. Each division between these numbers represents the third digit. The fourth digit can be estimated. The spaces

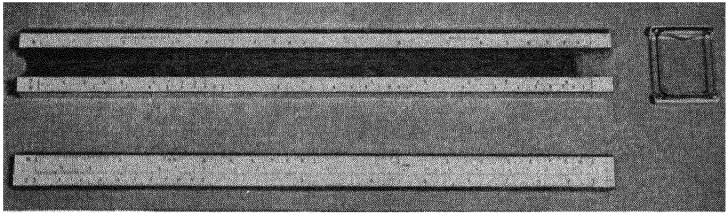

FIG. 2.—Slide rule, unassembled.

between the second digits are divided into two units, each having five divisions.

In using the slide rule, the decimal point is forgotten until the answer is found, and it is then placed by means of certain rules or, most commonly, as in arithmetic, by inspection. *In multiplication*, point off as many decimal places in the answer as there are decimal places in both numbers multiplied.

*In division*, work the problem as though both dividend and divisor were integers, pointing off the decimal as follows: (1) Move the decimal point to the left as many places as there are in the dividend. (2) Then move it back to the right as many places as there are in the divisor. Other ways of determining where to place the decimal in various kinds of problems are made by rough calculations.

The 1 on either end of the scale is called the *index*. It would seem logical, since the 1 on the left end represents number 1, that the 1 on the right end would represent 10; but, because the decimal point is ignored until the answer is found, they can both represent the same number.

There are three parts to the slide rule: the stationary scale, the moving scale, and the hairline. The *D* and *A* scales are the stationary scales, *C* and *B* scales the moving scales, and the hairline is mounted on a sliding glass plate.

*Steps in multiplying two numbers using the C and D scales:*

Step 1. Move the hairline to one number on the *D* scale.

Step 2. Move the *C* index (either index depending upon the next number) directly under the hairline.

- Step 3. Move the hairline to the second number on the *C* scale.  
 Step 4. Read the answer on the *D* scale under the hairline.

*Example 1.* Multiply  $14 \times 5$ .

- Step 1. Move the hairline to 14 on the *D* scale.  
 Step 2. Move the left *C* index under the hairline (so that the 14 line and the *C* index coincide).  
 Step 3. Move the hairline to 5 on the *C* scale.  
 Step 4. Read the answer on the *D* scale under the hairline. This falls directly on 7, and we place the decimal point by examination, giving an answer of 70.

*Example 2.* Multiply  $93 \times 47$ .

- Step 1. Move the hairline to 93 on the *D* scale.  
 Step 2. Move the right *C* index to the hairline.

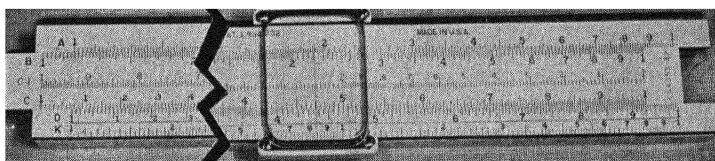

FIG. 3.—Slide rule, showing multiplication of Example 2.

- Step 3. Move the hairline to 47 on the *C* scale.  
 Step 4. Read the answer on the *D* scale under the hairline. It is 4,370.

*Steps in dividing two numbers using the C and D scales:*

- Step 1. Move the hairline over the dividend on the *D* scale.  
 Step 2. Slide the *C* scale so that the divisor on the *C* scale is under the hairline.  
 Step 3. Read the answer on the *D* scale under the *C* index.

*Example 3.* Divide 49 by 13.

- Step 1. Move the hairline to 49 on the *D* scale.  
 Step 2. Slide the *C* scale so that 13 on the *C* scale is under the hairline.  
 Step 3. Read the answer on the *D* scale under the *C* index. It is 3.77.

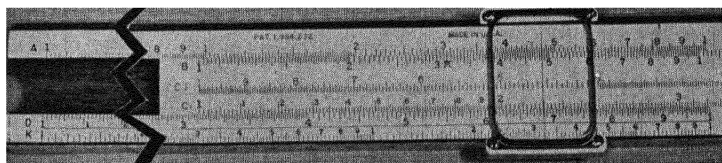

FIG. 4.—Slide rule showing answer to Example 5.

*Steps in using the C and D scale on problems that combine multiplication and division:* Consider a general problem  $\frac{r \times s}{t}$ .

#### 4 AERIAL SURVEYING AND PHOTO INTERPRETATION

- Step 1. Move the hairline to the value of  $r$  on the  $D$  scale.
- Step 2. Slide the  $C$  scale so that the value of  $t$  on the  $C$  scale is under the hairline.
- Step 3. Move the hairline to the value of  $s$  on the  $C$  scale.
- Step 4. Read the answer on the  $D$  scale under the hairline.

*Example 4.*  $\frac{17 \times 65}{36}$ .

- Step 1. Move the hairline to 17 on the  $D$  scale.
- Step 2. Slide the  $C$  scale so that 36 on the  $C$  scale is under the hairline.
- Step 3. Move the hairline to 65 on the  $C$  scale.
- Step 4. Read the answer on the  $D$  scale under the hairline. It is 30.7.

Sometimes it is necessary to shift the index of the  $C$  scale, as in the following example, where the denominator is larger than either number in the numerator.

*Example 5.*  $\frac{19 \times 22}{61}$ .

- Step 1. Move the hairline to 19 on the  $D$  scale.
- Step 2. Slide the  $C$  scale until 61 on the  $C$  scale is under the hairline.
- Step 3. Move the hairline to 22 on the  $C$  scale. Since this is impossible, it is necessary to shift the index from the right index to the left. This is done by moving the hairline to the  $C$  index, then sliding the  $C$  scale to the right until the other index is under the hairline. Then it is possible to move the hairline to 22.
- Step 4. Read the answer on the  $D$  scale under the hairline. It is 6.85.

*Steps in squaring a number:*

- Step 1. Move the hairline to the number on the  $D$  scale.
- Step 2. Read the answer under the hairline on the  $A$  scale.

*Example 6.* Square 21.

- Step 1. Move the hairline to 21 on the  $D$  scale.
- Step 2. Read the answer under the hairline on the  $A$  scale—441.

*Steps in taking square root:*

- Step 1. Move the hairline to the number on the  $A$  scale. If the whole number has an odd number of digits, use the left half

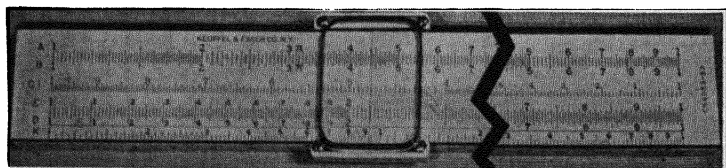

FIG. 5.—Slide rule, showing how to square a number (Example 6).

of the scale. If it has an even number of digits, use the right half of the scale.

Step 2. Read the answer on the *D* scale under the hairline.

*Example 7.* Find the square root of 742.

Step 1. The number has an odd number of digits. Locate 742 on the left half of the *A* scale.

Step 2. Read the answer on the *D* scale—27.2.

*Example 8.* Find the square root of 1,492.

Step 1. 1,492 has an even number of digits. Use the right half of the scale. Put the hairline over 1,492 on the *A* scale.

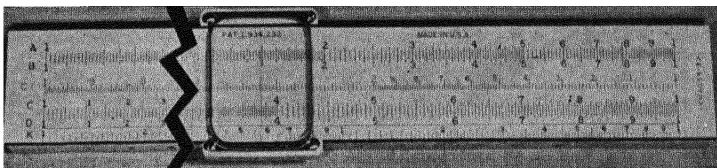

FIG. 6.—Slide rule, showing how to take a square root (Example 8).

Step 2. Read the answer on the *D* scale—38.6.

*Steps in working a proportion with the C and D scales:* Take the general proportion  $A:S::t:v$ .

Step 1. Move the hairline to the value of *S* on the *D* scale.

Step 2. Slide the *C* scale until the value of *A* is under the hairline.

Step 3. Move the hairline to the value of *t* on the *C* scale or *v* on the *D* scale.

Step 4. Read the answer on the scale opposite the one used in step 3.

*Example 9.*  $3:7::14:x$ .

Step 1. Move the hairline to 7 on the *D* scale.

Step 2. Slide the *C* scale until 3 on the *C* scale is under the hairline.

Step 3. Move the hairline to 14 on the *C* scale.

Step 4. Read the answer on the *D* scale—32.65.

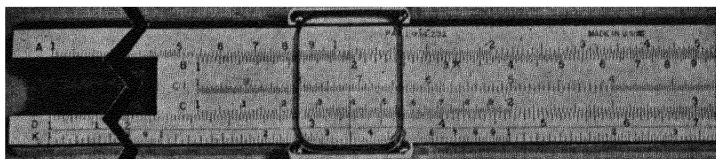

FIG. 7.—Slide rule, showing how to work a proportion (Example 9).

### Rules for Multiplication

**RULE I.** When the number is greater than one, add the number of digits to the left of the decimal point. If the *C* scale is to the left, the number of digits to the left of the decimal in the answer

is equal to the sum of the digits. If the *C* scale is to the right, the number of digits to the left of the decimal in the answer is equal to one less than the sum of the digits.

RULE II. When either or both numbers are less than one, follow the same rules as above, but consider that the number of digits to the left of the decimal point may be zero or negative according to the following system:

Number	Number of Digits to the Left of the Decimal
255.	3
25 5	2
2.55	1
0.255	0
0.0255	-1
0.00255	-2

### Rules for Division

RULE I. If the answer is under the left *C* index, the number of digits to the left of the decimal is one more than the difference between the number of digits to the left of the decimal in the dividend and in the divisor.

RULE II. If the answer is under the right *C* index, the number of digits to the left of the decimal is equal to the difference between the digits in the dividend and divisor.

The more common way of finding the decimal point is by examination.

#### Examination

$$776 \times 212 =$$

From the slide rule, we get 1,644.

To locate the decimal, we reason thus:

$$\begin{aligned} 776 \text{ is almost } 800 \\ 212 \text{ is almost } 200 \\ 200 \times 800 = 160,000 \\ \therefore 776 \times 212 = 164,400 \end{aligned}$$

### RATIO AND PROPORTION

A ratio is an expression of division between two quantities. The ratio is expressed usually as a fraction ( $a/b$ ) and sometimes in the form  $a:b$ .

A proportion is an equality of ratios. It can be expressed in three ways:

$$a:b::c:d \quad a:b = c:d \quad \frac{a}{b} = \frac{c}{d}$$

These are all read in the same way,  $a$  is to  $b$  as  $c$  is to  $d$ .

Steps in solving proportions  $a:b::c:d$  or  $a:b = c:d$

- Step 1. Multiply the two inside terms.
- Step 2. Multiply the two outside terms.
- Step 3. Let the product of step 1 equal the product of step 2.
- Step 4. Solve for the unknown term.

Example 1.  $5:18::14:x$ .

- Step 1.  $18 \times 14 = 252$
- Step 2.  $5 \times x = 5x$
- Step 3.  $5x = 252$
- Step 4.  $x = \frac{252}{5} = 50.4$

Example 2.  $9:x = 41:62$ .

- Step 1.  $41 \times x = 41x$
- Step 2.  $9 \times 62 = 558$
- Step 3.  $41x = 558$
- Step 4.  $x = \frac{558}{41} = 13.6$

Steps in solving proportion  $\frac{a}{b} = \frac{c}{d}$

- Step 1. Multiply the numerator on each side by the denominator on the other side.
- Step 2. Set the products equal to each other.
- Step 3. Solve for the unknown.

Example 3.  $\frac{7}{16} = \frac{2}{x}$

- Step 1.  $7 \times x = 7x$  and  $2 \times 16 = 32$
- Step 2.  $7x = 32$
- Step 3.  $x = \frac{32}{7} = 4.57$

Example 4.  $\frac{2}{19} = \frac{x}{40}$

- Step 1.  $2 \times 40 = 80$  and  $19 \times x = 19x$
- Step 2.  $19x = 80$
- Step 3.  $x = \frac{80}{19} = 4.2$

## LOGARITHMS

A logarithm of any number is the power to which it is necessary to raise a given number, called the *base*, to produce that number. In the logarithms used here, the base is 10. Since  $10^2 = 100$ ,  $\log 100 = 2$ . In the same way,  $\log 1,000 = 3$ . Since  $\log 100 = 2$  and  $\log 1,000 = 3$ , the log of any number that is greater than 100 and less than 1,000 must be between 2 and 3, or 2 plus a decimal.

A logarithm is made up of two parts, the whole number and the decimal. The whole number is called the *characteristic*; the decimal part is called the *mantissa*.



$\log 856.3 = 2.93263$ . The characteristic is 2, the mantissa is .93263. It can be proved that the characteristic depends only upon where the decimal point is in the number. Thus the logs of 261, 267.74, 976.412, 900, etc., all have a characteristic of 2. The mantissa of a number depends only upon the digits in the number, *i.e.*, the logarithms of 856.3, 8563, .0008563, etc., all have the same mantissa of .93263.

### Setting the Logarithm of a Number

Step 1. Determine the characteristic of the logarithm. There are two rules for this determination.

RULE I. For numbers greater than 1. The characteristic is always positive and is equal to one less than the number of digits to the left of the decimal point.

RULE II. For numbers less than 1. The characteristic is always negative and is equal to one more than the number of zeros between the decimal and the first significant figure.

Step 2. Look up the mantissa in the tables of logarithm.

*Example 1.* Find the log of 461.8.

Step 1. The characteristic (positive here) is 1 less than 3, or 2.

Step 2. From tables, the mantissa of 4,618 is .66445,

$$\log 461.8 = 2.66445.$$

*Example 2.* Find the log of .07951.

Step 1. The characteristic (negative here) is 1 more than 1, or  $-2$ .

Step 2. From tables, the mantissa of 7951 is .90042. Since the mantissa is always positive, the log is written thus:

$$\log .07951 = \bar{2}.90042 \quad \text{or} \quad \log .07951 = 8.90042 - 10$$

The latter form is the best to use.

### Steps in multiplication by logarithms:

Step 1. Look up the log of the first number.

Step 2. Look up the log of the second number.

Step 3. Add the two logs together.

Step 4. Look up the antilogarithm to find the answer.

*Example 3.*  $74.62 \times 826.7$ .

Step 1.  $\log 74.62 = 1.87286$

Step 2.  $\log 826.7 = 2.91735$

Step 3. Add  $\underline{4.79021}$

Step 4. The number whose mantissa is .79021 is 6,169. The characteristic 4 means it has 5 digits to the left of the decimal. The answer is 61,690.

*Example 4.*  $2.74 \times .007327$ .

Step 1.	log 2.74	=	.43775
Step 2.	log .007327	=	7.86552 - 10
Step 3.	Add		<u>8.30327 - 10</u>
Step 4.	antilog		.20103
			.020103 <i>Ans.</i>

*Steps in division by logarithms:*

- Step 1. Look up the log of the dividend.
- Step 2. Look up the log of the divisor.
- Step 3. Subtract the log of the divisor from the log of the dividend.
- Step 4. Look up the antilogarithm for the answer.

*Example 5.*  $527.6 \div 39.21$ .

Step 1.	log 527.6	=	2.72231
Step 2.	log 39.21	=	1.59340
Step 3.	Subtract		<u>1.12890</u>
Step 4.	antilog	=	13.455 <i>Ans.</i>

*Example 6.*  $.0792 \div 6.21$ .

Step 1.	log .0792	=	8.89873 - 10
Step 2.	log 6.21	=	<u>.79309</u>
Step 3.	Subtract		8.10564 - 10
Step 4.	antilog	=	.01275 <i>Ans.</i>

*Example 7.*  $3.42 \div .0582$ .

log 3.42	=	.53403
log .0582	=	8.76492 - 10

Since the log of the divisor appears larger than the dividend, we read-just as follows:

log 3.42	=	10.53403 - 10
log .0582	=	8.76492 - 10
Subtract		<u>1.76911 - 10</u>
antilog	=	58.76. <i>Ans.</i>

*Steps in raising a number to a power by logs:*

- Step 1. Look up the log of the number.
- Step 2. Multiply the log by the power.
- Step 3. Look up the antilog, which is the answer.

*Steps in finding the root of a number by logs:*

- Step 1. Look up the log of the number.
- Step 2. Divide the log by the root.
- Step 3. Look up the antilog, which is the answer.

**Interpolation.**—All mathematical tables give values for certain numbers. This is true for logarithm tables, trigonometric functions tables, and many others. Sometimes the number we have lies

between two adjacent numbers on the table. In this case the value in the table must be interpolated in order to obtain the correct value. For example, assume that a table has the logs for 3,672 and 3,673, but the log for 36,726 is wanted. This log lies between log 3,672 and log 3,673, and it is necessary to interpolate. Most interpolation is done with the following proportion:

$$du : Tu = dt : Tt$$

where  $du$  = difference between given number and lower number that is listed in table.

$Tu$  = total difference between the two adjacent numbers in table.

$dt$  = difference between value for given number and for lower value listed in table (unknown).

$Tt$  = total difference between tabulated values of the two adjacent numbers.

*Example 8.* Find log 36.726.

$$\begin{aligned} du &= 6 \\ Tu &= 10 \\ Tt &= .00012 \end{aligned}$$

Using proportion  $6 : 10 = dt : .00012$

$$dt = \frac{.00072}{10} = .00007$$

Add this to log of 36.720.

$$\log 36.726 = 1.56497$$

### TRIGONOMETRY

Trigonometry is defined as the study of the relationship of the sides of a triangle and the angles of the triangle.

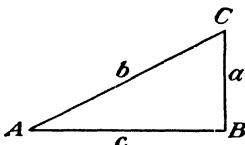

FIG. 8.

**Functions.**—In right triangle  $ABC$  (Fig. 8), there are three angles,  $A$ ,  $B$ , and  $C$  (angle  $B$  is a right angle) and three sides,  $a$ ,  $b$ , and  $c$  ( $b$  is the hypotenuse). For every angle there are six ratios of sides. These

ratios are called the six *functions* of the angle. They are as follows:

$$\text{Sine } A = \frac{a}{b} \text{ or } \frac{\text{opposite side}}{\text{hypotenuse}} \quad (\text{abbreviated } \sin A)$$

$$\text{Cosine } A = \frac{c}{b} \text{ or } \frac{\text{adjacent side}}{\text{hypotenuse}} \quad (\text{abbreviated } \cos A)$$

$$\text{Tangent } A = \frac{a}{c} \text{ or } \frac{\text{opposite side}}{\text{adjacent side}} \quad (\text{abbreviated } \tan A)$$

$$\text{Cotangent } A = \frac{c}{a} \text{ or } \frac{\text{adjacent side}}{\text{opposite side}} \quad (\text{abbreviated cot } A)$$

$$\text{Secant } A = \frac{b}{c} \text{ or } \frac{\text{hypotenuse}}{\text{adjacent side}} \quad (\text{abbreviated sec } A)$$

$$\text{Cosecant } A = \frac{b}{a} \text{ or } \frac{\text{hypotenuse}}{\text{opposite side}} \quad (\text{abbreviated csc } A)$$

**Numerical Values for Functions.**—It can be proved that any function is the same for any angle regardless of the size of the triangle. In other words, the sine of 30 deg. always has the same value whether the hypotenuse is 3 in. long or 5 miles. The same is true for any function. Therefore a table with the value of the ratios can be made with the value of the functions of each angle in the table.

Take an example of the functions using values for the side.

$$\sin A = \frac{\text{opposite}}{\text{hypotenuse}} = \frac{3}{5} = 0.60$$

$$\cos A = \frac{\text{adjacent}}{\text{hypotenuse}} = \frac{4}{5} = 0.80$$

$$\tan A = \frac{\text{opposite}}{\text{adjacent}} = \frac{3}{4} = 0.75$$

$$\cot A = \frac{\text{adjacent}}{\text{opposite}} = \frac{4}{3} = 1.33$$

$$\sec A = \frac{\text{hypotenuse}}{\text{adjacent}} = \frac{5}{4} = 1.25$$

$$\csc A = \frac{\text{hypotenuse}}{\text{opposite}} = \frac{5}{3} = 1.66$$

From the same triangle find the functions of angle  $C$ .

$$\sin C = \frac{\text{opposite}}{\text{hypotenuse}} = \frac{4}{5} = 0.80$$

$$\cos C = \frac{\text{adjacent}}{\text{hypotenuse}} = \frac{3}{5} = 0.60$$

$$\tan C = \frac{\text{opposite}}{\text{adjacent}} = \frac{4}{3} = 1.33$$

$$\cot C = \frac{\text{adjacent}}{\text{opposite}} = \frac{3}{4} = 0.75$$

$$\sec C = \frac{\text{hypotenuse}}{\text{opposite}} = \frac{5}{3} = 1.66$$

$$\csc C = \frac{\text{hypotenuse}}{\text{adjacent}} = \frac{5}{4} = 1.25$$

**Use of Trigonometric Tables.**—Finding the value of a function when the angle is known (assume the angle is expressed in degrees, minutes, and seconds).

## 12 AERIAL SURVEYING AND PHOTO INTERPRETATION

Step 1. Find a table that contains the function. Usually only two tables will be available—the sin and cos table and the tan and cot table.

Step 2. Turn to the page that contains the correct degrees.

Step 3. Follow the minute column down to the correct minute, and read the value in the table.

Step 4. Interpolate for seconds by this proportion: The number of seconds is to 60 as the addition to the value of step 3 is to the total difference between the value of step 3 and the next highest value. In this step, keep in mind that the value must be algebraic, *i.e.*, if the function increases as the angle increases, as in the case of the sine and tangent, the interpolated value must be added. However, if the function decreases as the angle increases, as in the case of the cosine and cotangent, the interpolated value must be subtracted.

A close examination of the tables will show that the values of degrees vary from 0 to 45 deg. at the top of the page with the minutes on the left-hand side of the page. At the bottom of the page are the angles from 45 to 90 deg., with the minute on the right-hand side. It will also be noted that, if the sine values are to the left for angles less than 45 deg., they will be to the right for angles greater than 45 deg. Great care must be used whenever the angle is greater than 45 deg. in order to prevent mistakes.

*Example 1.* Find  $\sin 23^{\circ}42'46''$ .

Step 1. Look up sin and cos tables.

Step 2. Find the column headed  $23^{\circ}$ .

Step 3. Follow the column down to 42' and get a value .40195.

Step 4. Interpolate:

$$46:60::x:(.40221 - .40195)$$

$$46:60::x:.00026$$

$$60x = .01194$$

$$x = .000199$$

$$\therefore \sin 23^{\circ}42'46'' = .40195 - .000199 = .402149, \text{ or } .40215$$

*Example 2.* Find  $\cos 58^{\circ}31'40''$ .

Step 1. Find cos and sin tables.

Step 2. Find the page with  $58^{\circ}$  (this will be on the bottom of the page).

Step 3. Go up the column to 40' (on the right side of page) and get a value of .52002.

Step 4. Interpolate:

$$40:60::x:(.52002 - .51997)$$

$$40:60::x:.00005$$

$$60x = .002$$

$$x = .00003$$

Since cos values decrease as the angle increases, the interpolated value must be subtracted from .52002,

$$\therefore \cos 58^{\circ}31'40'' = .52002 - .00003 = .51999$$

*Steps in finding the angle if the value of the function is known:*

- Step 1. Locate the value in the table nearest to the known value.
- Step 2. Read the degrees and minutes on the side.
- Step 3. Interpolate for seconds, using the same proportion as before.

*Example 3.*  $\sin x = .67722$ .

Step 1. Locate the nearest value in the table, .67709.

Step 2.  $42^{\circ}37'$  (degrees and minutes of .67709).

Step 3.  $\frac{x}{60} = \frac{.00013}{.00021}$

$$.00021x = 60 \times .00013$$

$$x = 37 \quad x = 42^{\circ}37'37'' \text{ Ans.}$$

**Solving Right-angle Triangles.**—The solving of right-angle triangles reduces itself to two problems. One is to find the angle or angles if the sides are known; the other is to find the side if an angle and one side is known.

If two sides of a right triangle are known, the third side can be found either by using the trigonometric functions or by the formula  $b^2 = a^2 + c^2$

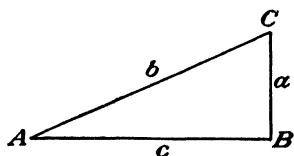

FIG. 9.

where  $b$  is the length of the hypotenuse and  $a$  and  $c$  are the two legs.

*Steps in finding an angle if two sides are known:*

- Step 1. Decide which function contains the two sides. If the hypotenuse is known, use either the sine or cosine depending upon the other known side. If the hypotenuse is not known, use the tangent.
- Step 2. Divide the ratio of the two sides.
- Step 3. Look up the angle in the tables.

*Example 4.* In Fig. 9, let  $c = 92'$  and  $b = 98'$ . Find angle  $A$ . Since hypotenuse and adjacent side are known, use the cosine.

$$\begin{aligned} \cos A &= \frac{92}{98} \\ \cos A &= .93877 \\ A &= 20^{\circ}9' \end{aligned}$$

*Example 5.* In Fig. 9, let  $c = 92'$  and  $b = 98'$ . Find angle  $C$ . Since hypotenuse and opposite side are known, use the sine

$$\begin{aligned} \sin C &= \frac{92}{98} \\ \sin C &= .93877 \\ C &= 69^{\circ}51' \end{aligned}$$

## 14 AERIAL SURVEYING AND PHOTO INTERPRETATION

NOTE: If Example 4 had been solved, we could find angle  $C$  by subtracting angle  $A$  from  $90^\circ$ .

*Steps in finding a side if an angle and side are known:*

Step 1. Determine the function to use having a ratio of the unknown side to the known side or reverse.

Step 2. Look up that function in the tables.

Step 3. Set ratio equal to that value and solve for unknown side.

*Example 6.* In Fig. 10, let  $c = 43'$  and angle  $A = 30^\circ 20'$ . Find  $b$ .

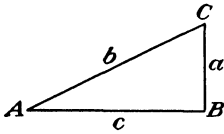

FIG. 10.

$$\begin{aligned} \frac{c}{b} &= \cos A \\ \cos 30^\circ 20' &= \frac{43}{b} \\ \cos 30^\circ 20' &= .86310 \\ 0.86310 &= \frac{43}{b} \\ b &= \frac{43}{.86310} = 49.8 \text{ ft.} \end{aligned}$$

*Example 7.* In Fig. 10, let  $c = 43'$  and angle  $A = 30^\circ 20'$ . Find  $a$ .

$$\begin{aligned} \frac{a}{c} &= \tan A \\ \tan 30^\circ 20' &= \frac{a}{43} \\ \tan 30^\circ 20' &= .58513 \\ a &= 43 \times .58513 \\ a &= 25.2' \end{aligned}$$

**Trigonometric Applications.**—Surveying and trigonometry work hand in hand. The simplest surveying work requires the use of trigonometry. No attempt will be made here to explain surveying, which will be taken up later, but the problems encountered will be examined. Two distinct problems often occur. The first is the computation of latitudes (distance traveled straight north or south) and departures (distances traveled straight east or west).

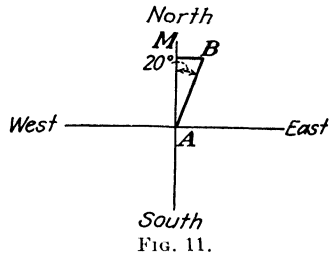

FIG. 11.

Suppose that the distance from point  $A$  to point  $B$  is 1,200 ft. and the direction is  $N.20^\circ E$ . The problem is how far is  $B$  north and east of  $A$ .

In Fig. 11,  $AB$  is a distance of 1,200 ft.  $AM$  is the distance  $B$  is north of  $A$ , or the latitude of  $AB$ .  $MB$  is the distance  $B$  is east of  $A$ , or the departure of  $AB$ . It can be seen that triangle  $ABM$  is a right triangle with the hypotenuse  $AB$  known and one angle known. This is one of the typical problems previously explained.

*Steps in finding the latitude of a line:*

- Step 1. Find the value of the cosine of the angle from north or south line.  
 Step 2. Multiply this value by the distance. The result is the latitude of the line.

*Steps in finding the departure of a line:*

- Step 1. Find the value of the sine of the angle from the north or south line.  
 Step 2. Multiply this value by the distance. The result is the departure of the line.

*Example 8.*  $AB$  is 1,200 ft. long in the direction of  $N. 35^{\circ}30' E.$  Find latitude and departure of  $AB$ .

Step 1.  $\cos 35^{\circ}30' = .81412$

Step 2. Multiply this value by the distance.  
 $1,200 \times .81412 = 976.94$   
 $\therefore$  Latitude of  $AB$  is 976.94 ft.

Step 1.  $\sin 35^{\circ}30' = .58070$

Step 2. Multiply this value by the distance.  
 $1,200 \times .58070 = 696.84$   
 $\therefore$  Departure of  $AB$  is 696.84 ft.

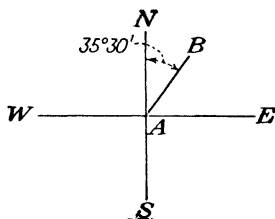

FIG. 11a.

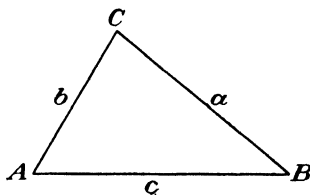

FIG. 12.

*Relationship of Functions.*—There are many relationships between functions of angles and the sides of triangles. In surveying we make use of two sets of formulas that apply to all triangles. They are called the *sine laws* and the *tangent laws*.

The sine laws are (from Fig. 12)

$$\frac{a}{\sin A} = \frac{b}{\sin B}$$

$$\frac{a}{\sin A} = \frac{c}{\sin C}$$

$$\frac{c}{\sin C} = \frac{b}{\sin B}$$



The tangent laws are

$$\tan \frac{1}{2}(A - B) = \frac{a - b}{a + c} \tan \frac{1}{2}(A + B)$$

$$\tan \frac{1}{2}(A - C) = \frac{a - c}{a + b} \tan \frac{1}{2}(A + C)$$

$$\tan \frac{1}{2}(B - C) = \frac{b - c}{b + a} \tan \frac{1}{2}(B + C)$$

The laws are used in a method of surveying called *triangulation*, which will be discussed more fully later. They are used when we cannot measure all the sides of the triangle but only one side and two angles. By using the laws we can find all the lengths of the sides. As a concrete example, suppose you were on an island and wanted to find the distance to an island that you could not reach or the distance between two points on an inaccessible island. You could find it by careful surveying and the use of the laws mentioned above.

Sometimes problems come up that involve angles greater than 90 deg. The following are some important relationships among the functions of angles greater and those less than 90 deg. Assume that angle  $M$  is greater than 90 deg.

$$\sin M = \sin (180 - M)$$

$$\cos M = -\cos (180 - M)$$

$$\tan M = -\tan (180 - M)$$

$$\sin M = \cos (M - 90)$$

$$\cos M = -\sin (M - 90)$$

$$\tan M = -\cot (M - 90)$$

## CHAPTER II

### SURVEYING

#### INTRODUCTION TO SURVEYING

This chapter is not intended to be a complete study of the art of surveying. It will present the elements of surveying as applied to the making of maps from aerial photographs and the field of aerial surveying. The topics presented will include the measurements of distance, direction, and elevation in obtaining the vertical and horizontal control necessary to make an aerial picture or group of pictures into a usable map.

**Definition.**—To survey is a verb defined in any standard dictionary as follows: "To determine the boundaries, position, extent, area, contour of, by measuring angles and distances and applying the principles of mathematics (arithmetic—geometry—trigonometry)."

**Uses.**—All important projects (engineering, construction, military maneuvers) extending over a considerable area or distance are necessarily based on elaborate and complete surveys. Under these heads must come highways, railroads, flumes, transmission lines, army training plans, offensive and defensive military actions, industrial plants, dams, and the like. The more scientific an operation is, the more detailed the surveys and resulting maps will be.

**Training Required.**—A widely varied training in addition to the actual instrument work is required for surveying. A review of the principles of geometry and trigonometry is needed, and training in the neat and systematic keeping of notes, a training that is worth while in any field, military or nonmilitary. Some experience with long and intricate calculations that cannot be solved haphazardly is often required in mapping and in drawing.

**Kinds.**—Surveys are divided into two general classes—plane surveys and geodetic surveys. In plane surveying, we pay no attention to the curvature of the earth. Most surveys are of this general type. In geodetic surveying, we take account of the curvature of the earth, considering it an oblate spheroid, commonly called *Clark's spheroid*.

There are four factors that control all surveys: (1) to secure the needed information (2) with suitable precision or accuracy (3) at a minimum cost and (4) often in a minimum time.

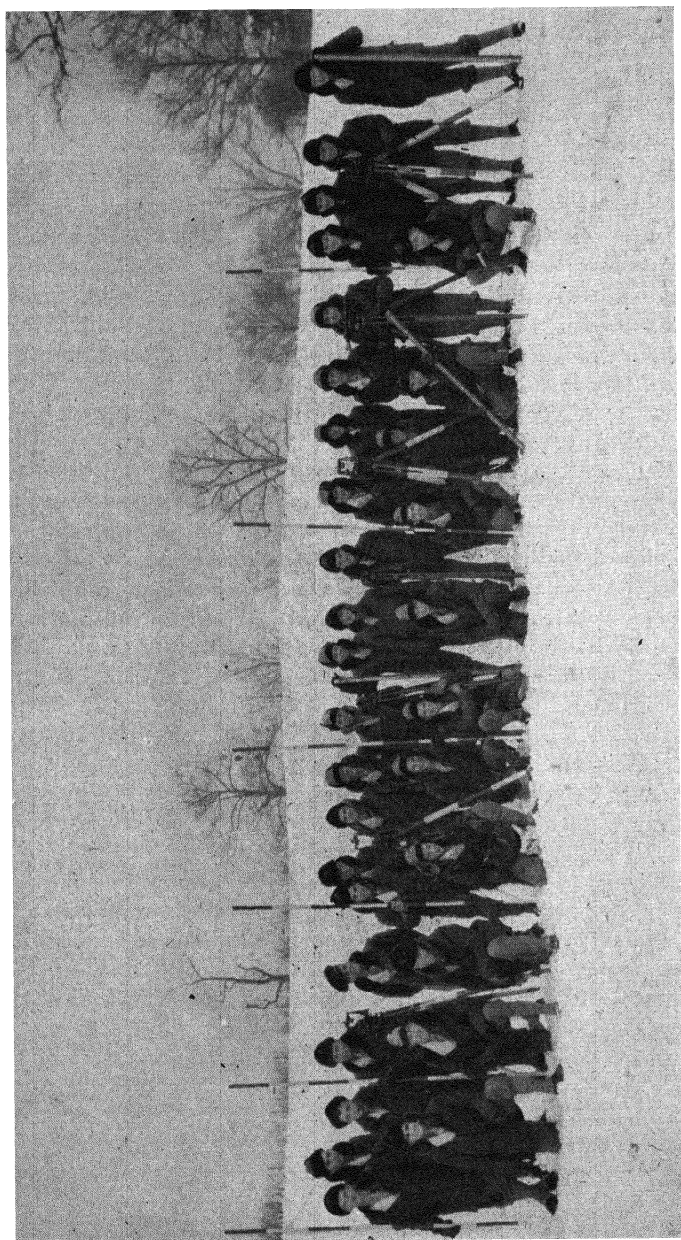

FIG. 13.—Students of the U.S. Marine Corps equipped for frigid weather proceed into the field for instruction in ground surveying.

## MEASUREMENT OF DISTANCES

**Introduction.**—Rough estimates of distances may be made by eye or may be scaled from maps or aerial photographs, occasionally by triangulation. The more common methods of taping and stadia will be discussed at this time, and we shall try to follow the customary rules as follows:

1. We shall decide the degree of precision needed.
2. We shall choose that system which will most conveniently secure the measurement wanted.

**Various Methods.**—The original method of obtaining measurements, of course, was the pace. This varies with different people, roughness of ground, fatigue, and many other factors. For pacing short distances, however, an average value of 3 ft. per pace is close enough for rough work. A good pacer will accomplish results accurate within 1 per cent.

The modern speedometer will give results as good as pacing if the route is smooth. Short wooden or steel rules are being used by mechanics and some surveyors for short distances. A more precise method is that of stadia, in which the interval on a stadia rod (a long narrow rod, rigid or collapsible, on which graduations are painted or stamped) cut off by lines of sight through the telescope and the stadia hairs (horizontal cross hairs in the telescope, one above and one below, equidistant from the center hair) multiplied by a factor (usually 100) is the distance. The errors involved tend to compensate, and results can be obtained to the order of  $\frac{1}{100}$  or better.

Another measuring device was the surveyor's chain, an assembly of 100 links, with a total length of 66 ft. You can readily see the relationship between this length and some of our common terms used today.

$$\begin{aligned} 1 \text{ mile (5,280 ft.)} &= 80 \text{ chains} \\ 1 \text{ rod (16.5 ft.)} &= \frac{1}{4} \text{ chain} \\ 1 \text{ acre} &= 43,560 \text{ sq. ft.} = 10 \text{ sq. chains} \end{aligned}$$

Although the chain itself has been abandoned, the job of measuring is still called *chaining*.

The most precise and at the same time probably the most expensive measurement of distance is by means of steel tapes, usually 100 ft. but sometimes 300 to 500 ft. in length. They are made of steel ribbon varying in width from about  $\frac{3}{8}$  to  $\frac{1}{4}$  in. in width, the popular size being about  $\frac{1}{4}$  in. Reels are provided by the manufacturers and are used quite extensively in larger tapes, but rarely in 100-ft. lengths

because it is much easier to coil these into a figure 8 and then throw that into a circle. Great care must be exercised in the use of the tapes to avoid kinking.

*To Measure on Sloping Ground.*—The tape is usually held level in measuring, because it is the horizontal distance that is wanted in the majority of cases. Sometimes it is possible to measure only slope distance, and in this case it must be reduced to a horizontal.

Figures 14 and 15 are illustrations of such necessary reductions.

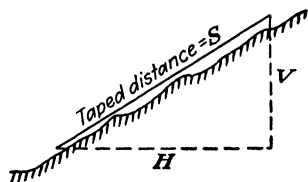

FIG. 14.— $S$  is longer than  $H$  by the approximate amount  $\frac{V^2}{2S}$ . Hence the correction to be subtracted from  $S$  to get  $H$  is  $\frac{V^2}{2S}$ .

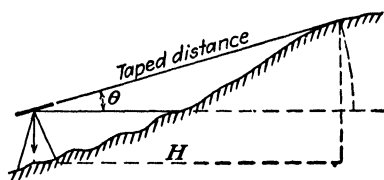

FIG. 15.— $H = \text{taped distance} - (\text{taped distance}) \text{ (vers } \theta)$ .

*Measurement of a Horizontal Distance on Level Ground.*—The usual chaining party consists of four men with the following equipment: a 100-ft. steel tape, 2 range poles, and 11 chaining pins.

Chaining a distance is done in such a way that at all times an accurate count of the number of tape lengths is known.

After the line to be measured has been determined, the rear chainman (with the 100-ft. end of the tape) takes one of the 11 pins and stations himself at the point of beginning. The head chainman is lined in by the rear chainman through the use of the range poles, and he places a pin at the 0-ft. mark. The head chainman then drags the tape forward until halted by the word "chain" from the rear chainman. "Chain" is used to denote the fact that the 100-ft. end of the tape is at the pin just placed by the head chainman. The process is repeated until the head chainman is out of pins. This will indicate, and be so recorded, that 1,000 ft. has been measured.

Care should be taken to keep an accurate check on the number of pins counted and to see that the head chainman is properly on the line at the time the pins are placed.

*Measurement of Angles with a Tape.*—There are methods, using trigonometry and geometry, of measuring the angles of a triangle through the use of a tape alone.

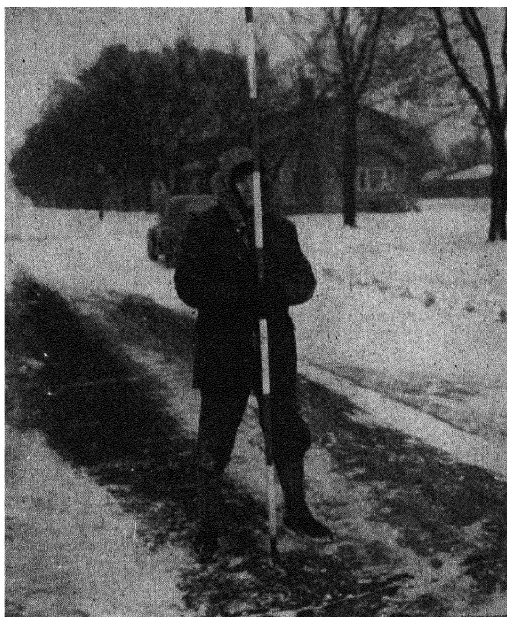

**FIG. 16.**—Holding a foresight for the transit party.



**FIG. 17.**—Taping under arctic conditions.

## 22 AERIAL SURVEYING AND PHOTO INTERPRETATION

METHOD 1.—To measure angle  $A$  (Fig. 18), an equal distance  $s$  is measured along the legs of the triangle, and pins are put in at  $e$  and  $f$ . The distance  $s$  should be at least 100 ft. The distance  $ef$  is then measured. To solve for angle  $A$  use the formula

$$\sin \frac{A}{2} = \frac{ef}{2s} \text{ (chord distance)}$$

METHOD 2.—To measure angle  $B$  (Fig. 18), a radius of at least 100 ft. is taken, and an arc is swung with a tape. One end is held by the rear chainman at the apex of the angle, and the head chain-

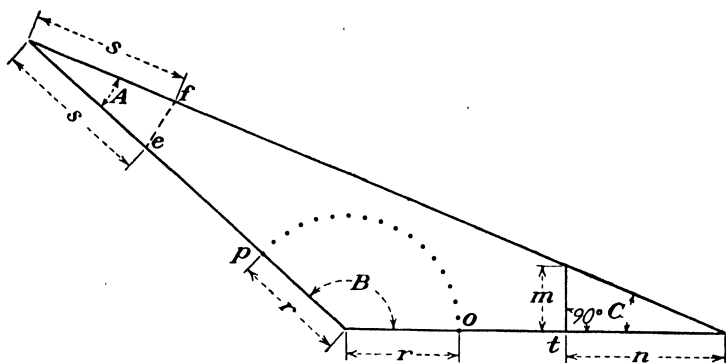

FIG. 18.

man places pins at  $o$  and  $p$ , and at 10-ft. intervals along the arc. Points  $o$  and  $p$  are located equidistant from the apex of the triangle and indicate where the arc would intersect the legs of the triangle. The arc is then measured by bending the tape to conform with the pins along the arc. The angle  $B$  in radians is found by using the formula

$$\text{Angle } B = \frac{op \text{ (arc length)}}{\text{radius } r}$$

Then, because there are 57.3 deg. in a radian, we can compute the value of angle  $B$  in degrees, by multiplying its value in radians by 57.3.

METHOD 3.—To measure angle  $C$  (Fig. 18), a distance  $n$  is measured from the apex of the angle, and at point  $t$  a line made perpendicular to the side just measured and extending to the other side of the angle is measured. This line can be estimated as perpendicular by the eye. The value of angle  $C$  is found by use of the following formula:

$$\tan \text{ angle } C = \frac{m}{n}$$

**Precautions in the Use of a Tape.**—It is, as mentioned before, the usual procedure to measure the horizontal distance. Several things that can interfere with the obtaining of the correct horizontal distance will be taken up in order.

*Temperature.*—Tapes are standardized usually at 68°F. and if used at any other temperature should have a correction applied to obtain the true horizontal distance. The coefficient of expansion and contraction of steel is 0.00000645 for each degree Fahrenheit rise or fall. This means, if the temperature should vary from 68°F., the tape would expand or contract 0.00000645 ft. for every foot of its length for each degree change, depending upon whether it was hotter or colder than the standard. If this is the case, the actual measured length could be greater or less than the measurement recorded in the book.

*Example.* A 100-ft. tape is standard at 68°F. A line is measured when the temperature was 99°F. and recorded as 1,432.87 ft. What is the actual length on the ground?

Tape is actually 100 ft. +  $100(99 - 68)(0.00000645)100$   
+ 0.019995 ft. = 100.019995 ft. long

$$\frac{\text{Actual tape length}}{\text{Recorded tape length}} = \frac{\text{actual ground distance}}{\text{recorded ground distance}}$$

$$\frac{100.019995}{100} = \frac{\text{actual ground distance}}{1,432.87}$$

Actual ground distance = 1,433.1565 ft.

*Sag.*—If the tape is not held in such a manner as to take the sag out of it, or if the wind is blowing the tape sideways, the distance as recorded will always be more than the actual ground distance.

*Pull.*—It is possible to stretch the tape by pulling too hard on it. If this is done the actual ground distance will be less than the recorded distance. The usual pull on a tape is 15 lb.

*Using a Mended Tape.*—Often, through careless use, a tape is broken and has to be repaired. If this is done the tape should be compared with a standard tape to see that it is of proper length.

### Common Mistakes in Reading and Recording Measurements of Distances

1. Failure to observe the zero point of the tape.
2. Transposing figures, *e.g.*, 25.48 for 25.84.
3. Reading the wrong foot mark.
4. Omitting a whole tape length in measuring long distances.

### MEASUREMENT OF DIRECTION

**The Surveyor's Compass.**—The surveyor's compass is an instrument for determining the horizontal direction of a line with reference



to the direction of a magnetic needle. This needle is balanced on a pivot at its mid-point and has a brass wire counterbalance on the south end to aid in overcoming the so-called "dip" of the needle and to balance the needle in a horizontal plane.

The needle has the property of pointing in a fixed direction called the *magnetic meridian*. The horizontal angle between the directions of this meridian and of any other line may be found by means of the graduated circle and is called the *magnetic bearing* or simply the bearing of the line.

*Declination.*—The direction that the needle assumes after the counterweight is in position (the magnetic meridian) rarely coincides with the real, or true, meridian. The angle between the true meridian and the magnetic meridian is called *declination*. When the north end of the needle points east of the true north, it is an east declination and when west, it is a west declination. The declination varies from year to year, and the determination of it is a duty of the U.S. Coast and Geodetic Survey. They furnish charts every 5 years. The chart resembles a contour map, but the lines connect points of equal declination instead of equal elevation. The line of 0 declination is called an *agonic line*. These charts are called *isogonic charts*.

*Use of Compass.*—It is possible to run a rough survey through the use of a compass and tape only. However, today, when a transit is available the compass is used primarily in rerunning old surveys, locating witness objects (trees, buildings, rocks, etc.) in transit stations, and roughly checking angles as read from a transit.

*Angles from Bearings.*—If the bearing of any two lines is known it is possible to compute the angle between the two lines (see Fig. 21).

Angle 1-0-2 = difference in bearings of 0-1 and 0-2

Angle 1-0-3 =  $180^\circ$  - sum of bearings of 0-1 and 0-3

Angle 1-0-4 =  $180^\circ$  - difference of bearings of 0-1 and 0-4

Angle 1-0-5 = sum of bearings of 0-1 and 0-5

*Bearings from Angles.*—Often it is necessary in the computation of a traverse to compute the bearings of the sides of the traverse from angles as measured by the transit. If an accurate bearing of one side of a traverse can be determined by triangulation or astronomical observation, then all bearings of that traverse can be computed in relation to that one side.

*Example.* Bearing from angles (see Fig. 22).

Given: Bearing of  $CB = N.3^\circ 18' E.$

Interior angle  $BCD = 91^\circ 23'$

Required: Bearing of  $CD$

*Solution:* Bearing of  $CD$  + angle  $BCD = 3^{\circ}18' + 91^{\circ}23' = 94^{\circ}41'$

$$180^{\circ}00' - 94^{\circ}41' = 85^{\circ}19'$$

Bearing of  $CD = S.85^{\circ}19'E.$

*Rerunning Old Survey Lines.*—In running old lines it is necessary to know the magnetic bearing at the time of the original survey and

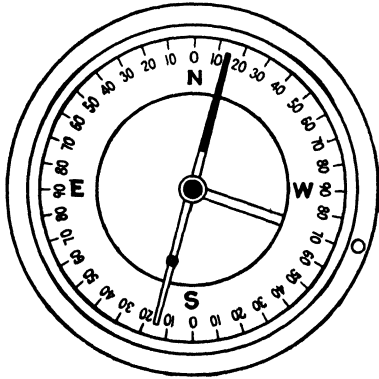

FIG. 20.—Face of a compass.

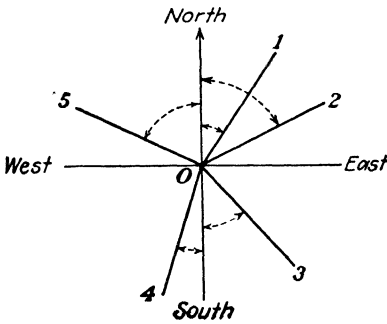

FIG. 21.

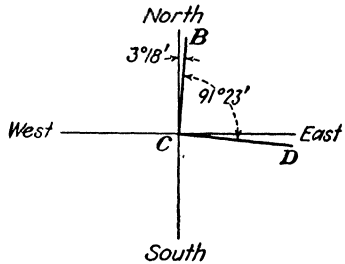

FIG. 22.

the declination at that time. Then to be sure of running the survey along the old lines it is necessary to compute the new magnetic bearing.

*Example.*

- Line  $AB$  Magnetic bearing, 1890 =  $N.32^{\circ}E.$
- Declination, 1890 =  $5^{\circ}W.$
- Declination, 1943 =  $5^{\circ}E.$
- Magnetic bearing, 1943 = ?
- True bearing, 1890 and 1943 =  $N.27^{\circ}E.$
- Magnetic bearing, 1943 =  $27^{\circ} - 5^{\circ} = N.22^{\circ}E.$

**Common Mistakes and Errors in the Use of a Compass**

1. Reading the wrong end of the needle.
2. Iron or steel near the compass affecting the needle.
3. Parallax in reading the needle caused by not looking vertically downward at the end of the needle.

**Measurement of Angles. *The Transit.***—The engineer's transit is an instrument designed primarily for measuring horizontal and vertical angles. In the main, it consists of a well-illuminated,

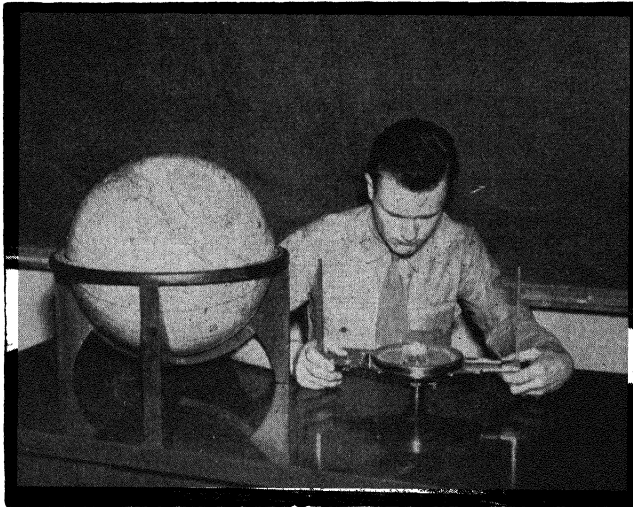

FIG. 23.—Student proving to himself that east is west and west is east on the compass.

medium-power telescope, vertical and horizontal circles with vernier (for closer reading), and the necessary tangent screws and tripod. The telescope will consist of three main parts: cross hairs, eyepiece, and objective lens.

*The vernier* accompanying the horizontal plates is a device to enable us to subdivide the reading on the scale more closely than is possible with the naked eye. One of the first things to do with any transit is to determine the value of the smallest reading of its vernier. This can be done as follows: Inspect the horizontal scale very closely. Set the vernier to read zero and determine the number of divisions on the scale that corresponds to some number of divisors in the vernier. You will soon see that, if we call the number of divisions on the scale  $N$ , there will be  $(N + 1)$  divisions corresponding in the vernier. If we set up the equation

$$\frac{x}{y} = N + 1$$

where  $x$  = value of one division in the scale,  
 $y$  = least reading on the vernier,  
 then  $x$  and  $y$  must be in the same units.



FIG. 24.—Reading and recording the doubled angle.

For instance, if 29 divisions on the scale correspond to 30 divisions on the vernier and each division on the scale is 30 minutes, what will be the least reading of the transit?

$$\frac{x}{y} = N + 1 \quad \frac{30}{y} = 29 + 1 \quad y = 1 \text{ minute}$$

Many angles are reported with an erroneous value, just because the observer did not follow this one simple rule concerning the reading of verniers.

**Remember.**—Always read along the main scale, in the direction in which the degrees are increasing, to the zero of the vernier. Then cross over to the vernier and read in the same direction along the vernier to the point of coincidence of the lines.

*Setting Up the Transit.*—The transit is first set up with the plumb bob approximately over the stake, tack, or nail, with the tripod head approximately level. The tripod is then lifted bodily and, without changing the position of the legs, is moved until the plumb bob hangs about  $\frac{1}{4}$  in. above the point on the stake. The legs are

then sunk solidly into the ground. If necessary, the head of the transit can be shifted slightly after the legs have been set so as to have the plumb bob directly over the point. The transit is turned about its vertical axis until the bubbles are over respective pairs of leveling screws. One bubble is then approximately centered and then the other one. This process is repeated with closer approxi-

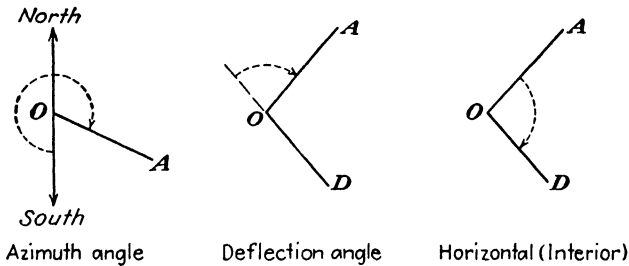

FIG. 25.

mations until both bubbles remain centered wherever the telescope is turned.

#### Measuring Horizontal Angles

1. Set instrument up as described in previous article.
2. Set vernier (horizontal plate vernier) to  $0^{\circ}00'$  by using the upper and lower tangent and slow-motion screws. Then clamp upper motion screws. Both plates are run as one.
3. Point the telescope along one line of the angle. The lower motion clamp and slow-motion screw are used, after sighting at the point.
4. Loosen the upper motion and rotate the telescope about the vertical axis until the vertical  $\times$  hair is exactly on the point defining the second line of the angle.

5. Read angle turned off, using both main scale and vernier.

*Classes of Angles.*—There are several kinds of angles that may be read in the field and used to compute bearings of the respective lines: (1) azimuth angles, (2) deflection angles, and (3) horizontal angles, clockwise or counterclockwise.

*Azimuth.*—Angle clockwise to the right from the south point. This method gives a very rapid computation of the bearing. Sometimes the azimuth is taken from true north.

*Deflection Angle.*—Angle swung to the right or left of a prolongation of the previous line. This is probably the next easiest method to compute bearings.

*Horizontal.*—This includes interior and exterior angles, and, though it is a popular method, is not so easy to compute from as the first two.

One of the many jobs for which a transit is used is that of running a traverse. A traverse (open or closed) is a series of lines whose length and bearing are known. It is made by occupying, one at a time, a series of stations; reading the particular angles that the traverse lines that meet at that point make with each other; and measuring the length of lines meeting at that point. Upon completion of the field work, several rapid checks can be made on the work of reading the angles.

**Remember:** *Check 1.* The sum of all interior angles must add up to  $(N - 2) 180$  deg.  $N$  = number of sides of traverse. This applies to any shape of traverse.

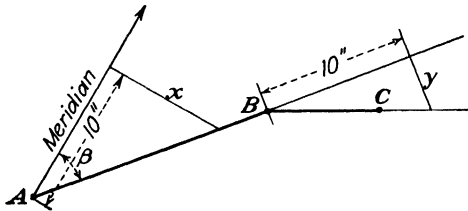

FIG. 26.— $x = 10 \tan$  bearing  $AB$ .  $y = 10 \tan$  deflection angle at  $B$ .

*Check 2.* The sum of all deflection angles (with due regard to sign) must add up to 360 deg.

**Plotting a Traverse.**—There are several ways of plotting a traverse on paper. The two most common for an open traverse are the *chord method* and the *tangent method*. For plotting a closed traverse the rectangular coordinate method is the most used.

*Tangent Method.*—First draw a meridional line (magnetic or true north) on the paper. Lay off along this line a distance of 10 in., and at this point erect a perpendicular (to the right if bearing is east and to the left if bearing is west). Along this perpendicular measure to scale a distance equal to  $\tan$  bearing line  $AB \times 10$ . Through this point draw line  $AB$  to the correct distance of  $AB$  as measured in the field. From point  $B$  measure 10 in. along a continuation of  $AB$  and erect a perpendicular again (to the right or left depending upon the deflection angle this time). Measure along this perpendicular the distance  $10 \times \tan$  deflection angle at  $B$ . Continue traverse in this way until plotted.

*Rectangular Coordinate Method.*—This method is very accurate, for angles can be plotted on paper to the degree of accuracy in which they were read in the field.

Every line in the traverse has a departure and a latitude which can be computed. Figure 27 shows the meaning of latitude and departure.

*Departure* of a point is the distance that point is east or west of a north-south line. Departure is plus if east, minus if west.

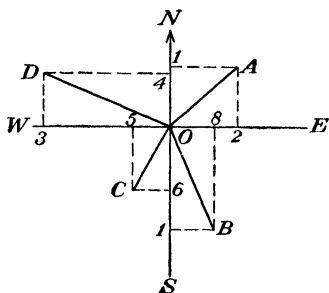

FIG. 27.

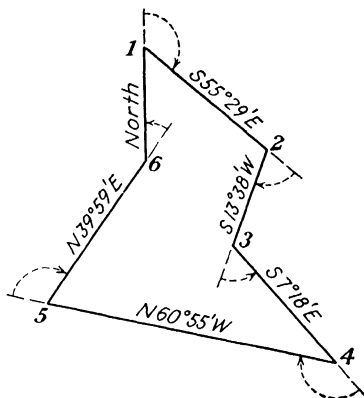

FIG. 28.

*Latitude* of a point is the distance that point is north or south of an east-west line. Latitude is plus if north, minus if south.

In Fig. 27, the latitude of  $\angle A$  is  $+(1-0)$ . The latitude of  $\angle D$  is  $+(0-4)$ . The departure of  $\angle A$  is  $+(2-0)$ . The departure of  $\angle D$  is  $-(0-3)$ .

Given: The following traverse.

Station	Deflection angle	Distance, feet
1	124°31' right	118.17 (1-2)
2	69°07' right	106.17 (2-3)
3	20°56' left	91.39 (3-4)
4	126°23' right	156.55 (4-5)
5	100°54' right	82.19 (5-6)
6	39°59' left	121.67 (6-1)

The nine steps in the computation of the above traverse will now be listed and worked in the order in which they should be done.

1. Check the angles to see if they satisfy the rule that deflection angles add to 360 deg. with due regard to sign.

$$\begin{array}{r}
 + \text{right angles} = 420^{\circ}55' \\
 - \text{left angles} = \quad 60^{\circ}55' \\
 \hline
 360^{\circ}00'
 \end{array}$$

2. Compute the bearing of all sides from one assumed correct bearing or one on which an accurate observation has been made.

In Fig. 28, side 6-1 has a bearing of north.



FIG. 29.—Obtaining horizontal control with transit and tape.

3. Compute the latitudes and departures of each side. It can be seen that by trigonometry the latitude and departure of each side can be figured by using the following rule:

$$\begin{array}{l}
 \text{Departure} = \sin \text{ bearing} \times \text{distance} \\
 \text{Latitude} = \cos \text{ bearing} \times \text{distance}
 \end{array}$$

An easy accurate way of computation is to set up a table, as shown below:

		Side 1-2
1. Departure		+97.37 (antilog No. 2)
2. log departure		.11.9884141 - 10 (No. 3 + No. 4)
3. log sin bearing	log sin 55°29'	= 9.9159069 - 10
4. log distance	log 118.17	= 2.0725072



## 32 AERIAL SURVEYING AND PHOTO INTERPRETATION

5. log cos bearing    log cos 55°29' = 9.7533118 - 10  
 6. log latitude                            11.8258190 - 10 (No. 4 + No. 5)  
 7. Latitude                                 66.96 (antilog No. 6)

4. Add the plus and minus latitudes. Add the plus and minus departures.

Station	Deflection angle	Distance, feet	Computed bearing	Latitude		Departure	
				+N.	-S.	+E.	-W.
1	124°31'R.						
1-2		118.17	S.55°29'E.		66.96	97.37	
2	69°07'R.						
2-3		106.17	S.13°38'W.		103.19		25.03
3	20°56'L.						
3-4		91.39	S.7°18'E.		90.65	11.61	
4	126°23'R.						
4-5		156.55	N.60°55'W.	76.10			136.81
5	100°54'R.						
5-6		82.19	N.39°59'E.	62.98		52.81	
6	39°59'L.						
6-1		121.67	North	121.67		0	
Total	360°00'	656.15		+260.75	-260.80	+161.79	-161.84

FORM 1.

5. If the plus and minus latitudes do not add algebraically to zero, it is necessary to adjust the traverse so that they do.

The linear error of closure can be computed by finding the hypotenuse of the right triangle formed by the differences in latitude and departure.

To determine whether the traverse in Fig. 28 can be adjusted in the office or whether the distances should be remeasured, it is necessary to know what degree of accuracy is desired.

The accuracy required for the usual horizontal control in aerial mapping is about 1:5,000. To compute the accuracy of the traverse, add the distances of each of the sides comprising the perimeter.

$$\text{Accuracy} = \frac{\text{linear error of closure}}{\text{perimeter}} = \frac{0.072}{656.15}$$

To put it on a basis of unity, set up a proportion as follows:

$$\begin{aligned} 0.072 \text{ ft.} : 656.15 : : 1 \text{ ft.} : x \\ 0.072x &= 656.15 \\ x &= 9,113 \end{aligned}$$

This means that for every 9,113 ft. measured there was an inaccuracy of 1 ft.

To balance the traverse we must make the latitudes add algebraically to zero, and the departures must add algebraically to zero.

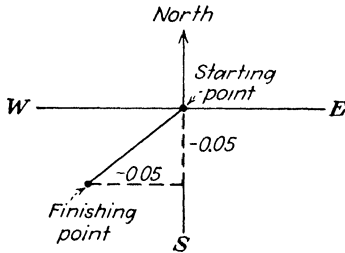

FIG. 30.

Departure	Latitude
-161.84	+260.75
+161.79	-260.80
- 0.05	- 0.05

$$\text{Linear error} = \sqrt{0.05^2 + 0.05^2} = 0.072'$$

To do this, in the above example, it is necessary to reduce the minus latitudes and increase the plus latitudes, and likewise to reduce the minus departures and increase the plus departures. The formula used is known as the transit rule and is as follows:

The correction to be applied to the  $\left\{ \begin{matrix} \text{latitude} \\ \text{departure} \end{matrix} \right\}$  of any course is to the total error in  $\left\{ \begin{matrix} \text{latitude} \\ \text{departure} \end{matrix} \right\}$  as the  $\left\{ \begin{matrix} \text{latitude} \\ \text{departure} \end{matrix} \right\}$  of that course is to the arithmetical sum of all the  $\left\{ \begin{matrix} \text{latitudes} \\ \text{departures} \end{matrix} \right\}$  in the traverse.

*Example.* Side 1-2.

$$\begin{aligned} \frac{\text{Correction to latitude 1-2}}{0.05} &= \frac{66.96}{260.75 + 260.80} \\ \text{Correction to latitude 1-2} &= 0.01 \\ \text{Balanced latitude 1-2} &= 66.96 - 0.01 = 66.95 \\ \frac{\text{Correction to departure 1-2}}{0.05} &= \frac{97.37}{161.79 + 161.84} \\ \text{Correction to departure 1-2} &= 0.005 \\ \text{Balance departure 1-2} &= 97.37 + 0.004 = 97.37 \end{aligned}$$

### 34 AERIAL SURVEYING AND PHOTO INTERPRETATION

Computation form 2 shows the complete computations of a closed traverse.

Line	Latitude		Departure		Balanced latitude and departure		Rectangular coordinates	
	+N.	-S.	+E.	-W.	Latitude	Departure	X	Y
1-2		66.96	97.37		- 66.95	+ 97.37	0	76.11
2-3		103.19		25.03	-103.18	- 25.02	52.83	139.09
3-4		90.65	11.61		- 90.61	+ 11.62	52.83	260.77
4-5	76.10			136.81	+ 76.11	-136.79	150.10	193.82
5-6	62.98		52.81		+ 62.98	+ 52.82	125.08	90.64
6-1	121.67		0		+121.68	0	136.67	0
Total	+260.75	-260.80	+161.79	-161.84	0	0		

FORM 2.

6. The next step is the computation of the rectangular coordinates of each point. The usual procedure is to draw a horizontal line through the most southerly point on the traverse and a vertical

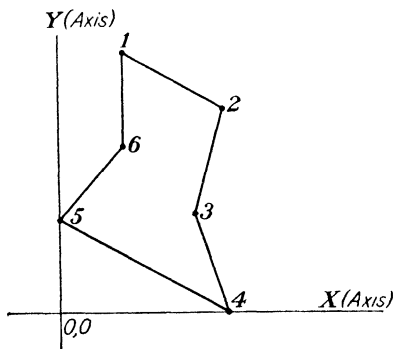

FIG. 31.

line through the most westerly, and call the point where these two lines intersect the origin, or (0, 0) point, of the coordinate system.

7. The next step is to determine from your scale the size of paper for plotting that is required. To do this, find the largest  $x$  coordinate (150.10) and the largest  $y$  coordinate (260.77). Knowing the scale and allowing for a suitable border, the size of paper can be determined.

SCHOOL OF AERIAL SURVEYING AND MAPPING													
ABRAMS AERIAL SURVEY CORPORATION													
Lansing, Michigan U S A.													
Computation Sheet													
TRAVERSE		DATE			PARTY NO			CORR. LAT.			TOTAL DEP.		
KIND		Jan 20, 1943			2						0		
NUMBER		Closed			Covington-May-Curfus								
		5 Side			Day-Bryan-De Vaux								
COURSE	DEFLECTION INTERIOR EXTERIOR ANGLE	MAGNETIC BEARING TRUE COMPUTED BEARING AZIMUTH BEARING	HOR. DIST.	NAT. COS	LAT.	NAT. SIN	DEP.	CORR. FOR LAT	CORR. FOR DEP.	CORR. LAT.	CORR. DEP.	TOTAL LAT	TOTAL DEP.
A													
A - B	139°-18'	N 76° - 40' E	3303.0	.23062	+ 761.64	.97304	+ 3213.95			+ 761.74	+ 3213.95	0	0
B - C	69°-34'	S 62° - 38' E	5733.0	.45968	2635.34	.88808	+ 5091.36			- 2635.34	+ 5091.26	+ 761.74	+ 3213.95
C - D	118°-27'	S 47° - 48' E	10006.0	.67172	6721.23	.74080	+ 7412.44	- .1	- .1	6721.33	+ 7412.54	- 1863.60	+ 8305.21
D - E	108°-46'	N 70° - 39' W	1754.0	.33134	+ 581.17	.94351	+ 1654.92			+ 581.17	+ 1654.92	- 8584.93	+ 892.67
E - A	103°-55'	N 5° - 26' E	8050.0	.99551	+ 8013.86	.09469	+ 762.25	- .1		+ 8013.76	+ 762.25	0	0
Error = $\sqrt{(1.2)^2 + (.282)^2}$		per. = 28846.0		+ 9356.77		+ 9067.56				0			
Error of closure = $\sqrt{(1.2)^2 + (.282)^2}$		28846		- 9356.77		- 9067.36							
				+ 0.20		+ 0.20							
<p>Note: - The error is so small, we will not use any rule of distribution, but will proportion it equally between 2 largest Latitudes and 2 largest Departures</p>													
Error of closure = $\frac{.282}{28846} \times 102288$		About 1 in 100000											

### 36 AERIAL SURVEYING AND PHOTO INTERPRETATION

8. The last step is to plot the position of the traverse stations. Each point is plotted independently with the use of a straightedge and ruler only. Calling the lower left-hand corner of the border the point (0, 0) of coordinates, measure up on the left and right border lines the  $x$  distance of the first point to plot. Measure from

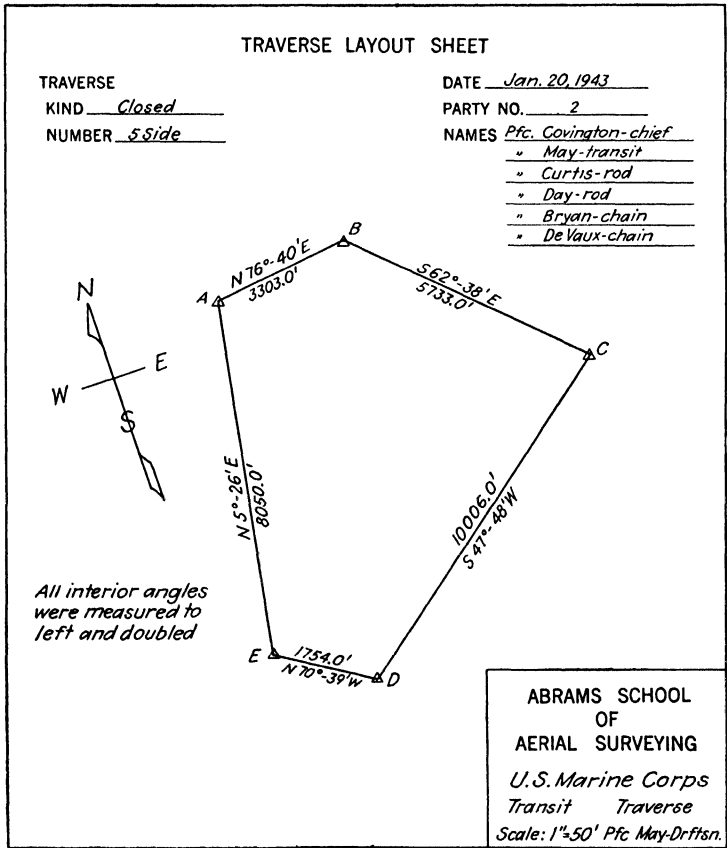

FORM 4.

the point of origin on the upper and lower border lines the  $y$  coordinates of the same point. Connect these two sets of points. The intersection of the two lines is the location of the point on the map.

9. In drawing up the traverse, it is the usual practice to use red ink for traverse lines and small circles to denote traverse stations. In arranging the work have the north arrow point toward the top of the

sheet. Show on each line the bearing and distance of that line, as shown in Fig. 35.

Station	X	Y
5	0	Lat. 4-5 = 76.11
6	Dept. 5-6 = 52.83	Lat. 4-5 + Lat. 5-6 = 76.11 + 62.98 = 139.09
1	Dept. 5-6 + Dept. 6-1 = 52.83 + 0 = 52.83	139.09 + Lat. 6-1 = 139.09 + 121.68 = 260.77
2	52.83 + Dept. 1-2 = 52.83 + 97.37 = 150.10	260.77 + Lat. 1-2 = 260.77 - 66.95 = 193.82
3	150.10 + Dept. 2-3 = 150.10 - 25.02 = 125.08	193.82 + Lat. 2-3 = 193.82 - 103.18 = 90.64
4	125.05 + Dept. 3-4 = 125.05 + 11.62 = 136.67	90.64 + Lat. 3-4 90.64 - 90.64 = 0

FORM 5.

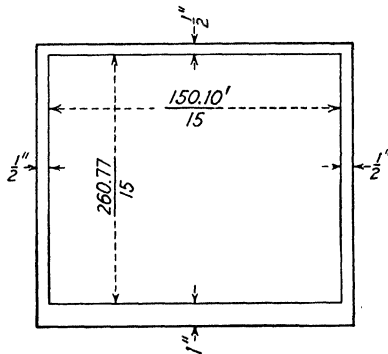

FIG. 32.—Drawn to a scale of 1 in. = 15 ft. This would require a paper  $\frac{150.10}{15} + \frac{1}{2}$  in. +  $\frac{1}{2}$  in. wide = 11 + in. and  $\frac{260.77}{15} + \frac{1}{2}$  in. + 1 in. long = 18.88 in.

**Precautions in the Use of the Transit**

1. Set the transit up firmly, with its legs firmly set in the ground.
2. Read the proper vernier.
3. Be sure the instrument is in proper adjustment.



FIG. 33.—Plotting horizontal control from a transit traverse, geodetic triangulation, and solar observations.

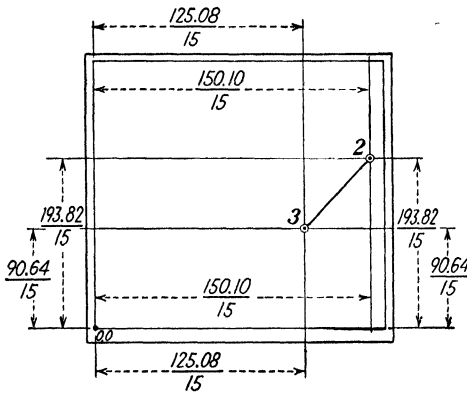

FIG. 34.—Showing "good practice" in planning layout of traverse on a map.

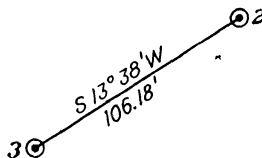

FIG. 35.—Correct dimensioning of a traverse line on a map.

4. Read the proper main scale. If the telescope is turned clockwise, read the main scale going clockwise. If the telescope is turned counterclockwise, read the main scale, which is numbered counterclockwise.

### LEVELS AND LEVELING

**Introduction.**—Another adaptation of the ordinary telescope (the same as that in a transit) is in level work. The engineer's level consists essentially of a telescope defining a line of sight, and an attached sensitive bubble tube. If the level is in adjustment every time the bubble is centered in the tube, the line of sight is horizontal. The standards, leveling screws, tripod, etc., are only extras that are used for convenience. The instrument itself is used with a level rod, to determine difference of elevation. Elevation is the vertical displacement of one point above or below a known datum place, usually sea level, but any other base could be used.

A level surface is an approximately spherical surface, concentric with the surface of a body of water. It is therefore not a plane, but a curve surface. It is at all points perpendicular to the pull of gravity. A horizontal plane is a plane tangent to a level surface.

#### Terms Used in Leveling

*Height of Instrument (H.I.)*.—The height of the telescope tube above the datum plane. Found by adding the backsight reading to the bench mark elevation.

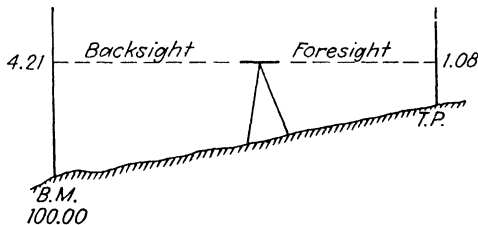

FIG. 36.

*Bench Mark (B.M.)*.—A permanent point of known elevation.

*Backsight (B.S.)*.—A rod reading on a rod held at a known point of elevation.

*Foresight (F.S.)*.—A rod reading held on a point of unknown elevation.

*Turning Point (T.P.)*.—A temporary point of known elevation.

**Differential Leveling.**—In Fig. 36, the elevation of T.P.1 is to be obtained. After it has been obtained the level line can be continued and the point T.P.1 can be treated as a B.M. temporarily.



A rod is held on the B.M. and the instrument is set up within 300 ft. of it. To set the instrument up, the same care is taken as with a transit, it being important that the level bubble remains in the center of the tube as the telescope rotates 360 deg. around its vertical axis. The reading taken on the rod at the B.M. is known as a backsight



FIG. 37.—Student holding a level rod on a foresight to obtain vertical control.

(often referred to as a plus sight). This reading 4.21 is added to the B.M. elevation to give the H.I. (104.21). Then the foresight reading (often referred to as a minus sight) is taken on a rod held on the T.P., the point at which an elevation is desired. This F.S. reading (1.08) is subtracted from the H.I. to obtain the elevation of the point T.P. (103.13).

A check on the computations is to add the B.S. readings and the F.S. readings, and the difference should equal the difference in elevation between the B.M. and T.P.

$$4.21 - 1.08 = 3.13 \quad 103.13 - 100.00 = 3.13 \text{ (check)}$$

**Accuracy Required.**—For work in connection with aerial photographs the accuracy required should be as follows:

$$K = 0.05 \sqrt{D}$$

where  $D$  = distance level circuit, miles.

$K$  = difference in elevation on the point from which the level survey started and finished. If the survey is not a closed circuit, than  $K$  is the difference in elevation as obtained in leveling on the ending B.M. from what the elevation should be.



FIG. 38.—Differential leveling with Wye level.

### Precautions to Take in Leveling

1. Have the telescope tube always level at the time readings are taken on the rod.
2. Keep the backsights and foresights the same distance from the level and not over 300 ft. away.
3. Hold the level rod plumb at the time the reading is taken.
4. Select turning points that are stable enough so as not to change elevation during use.

### PLANE-TABLE METHOD

**Definition.**—A plane table is an instrument by means of which points in the field are located directly on the map by graphic methods,

the map being fastened to a table top supported by a tripod, from which the instrument derives its name.

**Advantages of Method.**—The only true advantage of the plane-table method of making maps over the transit and tape survey is that the map is made in the field, and detail can be sketched on the



FIG. 39.—Using a plane table and alidade in the field for establishing control and topographic sketching.

location. It is more or less dependent upon weather conditions and to be really accurate should be controlled by a transit traverse.

### Instruments Used

1. Plane table.
2. Alidade.

The plane table is of several types, ranging from a simple sketch board to an elaborate leveling head type. The usual type, known as the Johnson table, is a board 24 by 30 in., mounted on a tripod and adjustable for both level and azimuth.

The alidade is the instrumental part of the equipment and consists usually of a telescope mounted on a rigid straightedge. It is approximately the same power as a transit telescope, has cross hairs for sighting and stadia, a vertical circle for vertical angles, and a level bubble for leveling. An engineer's scale or a compass alidade can be used in place of the telescopic type of alidade if accuracy is not a prime requisite.

**Location of Points on Map**

*By Intersection*

1. To begin a survey, have on the map the plotted position of two known points on the ground (base line), as shown in Fig. 40.

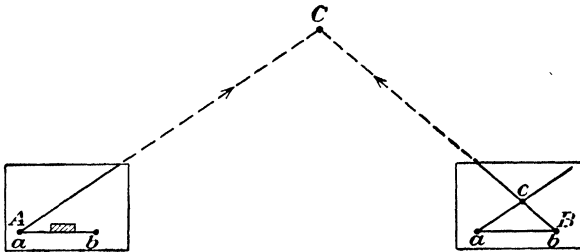

FIG. 40.

2. Place plane table over point *A* on the ground with small *a* on map directly over *A*.

3. Place alidade on line *ab*.

4. Rotate table and sight point *B* by looking along *ab* through *b*.

5. Clamp the table, which is now oriented.

6. Sight *C* by revolving the alidade around point *a*, and draw an indefinite line from *a* toward *C*.

7. Repeat this process at *B* and orient. Sight at *C* and draw another line on map. The intersection of those two lines is the point *c*, the plotted position of *C*.

*By Resection.*—Sometimes it is not possible for both ends of a known plotted base line to be occupied. When this happens, we use resection to continue the survey (see Fig. 41).

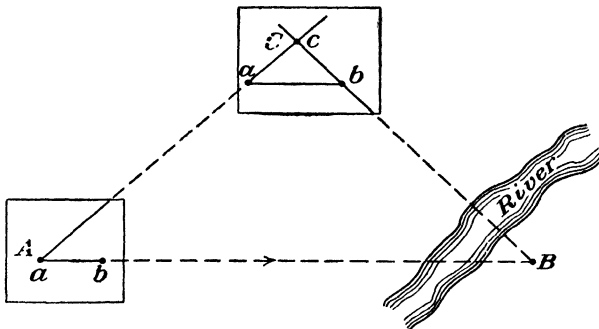

FIG. 41.

1. Orient table at *A*, as was done in intersection, by placing alidade along *ab*, sighting at *B* through *b*, and clamping.

2. Draw a line from  $a$  toward  $C$ .

3. Move the table to  $C$  and make  $C$  on the ground directly below the line just drawn and approximately at the point of the correct estimated position of  $C$ .

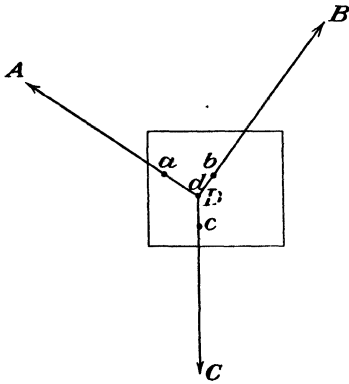

FIG. 42.

4. Orient table by means of this line by sighting along this line through  $a$  to  $A$ .

5. Rotate alidade around  $b$ , sight to  $B$ , and draw a resection line  $bc$ . The point at which the two lines intersect is the plotted position of  $C$ .

*Three-point Problem.*—One of the great advantages of the plane table is that it may be set up any place where three triangulation points (plotted on the sheet) can be seen; the position of the table

can be plotted simply by observations from this one location. The usual method of solving this problem is by means of Lehmann's

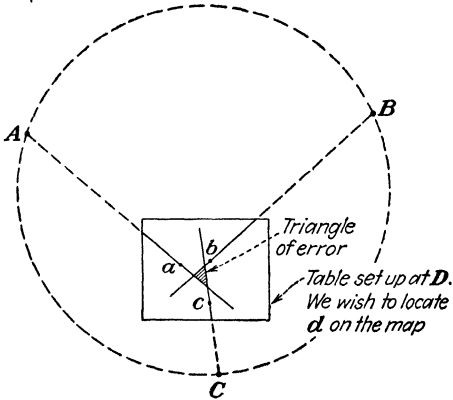

FIG. 43.

method, commonly referred to as the "triangle of error" method (see Fig. 43).

If the table could be placed over  $D$  on the ground in the correct position in relation to  $ABC$  (known triangulation points), the resection lines would pass through  $d$ , the plotted position of the point  $D$ .

However, since we have no method of correctly orienting the table, it is done by trial.

*Steps in three-point problem:*

1. Set table up over point  $D$ , which is to be located on the map.
2. Sight through the plotted position of  $a$  toward  $A$  and clamp the table. Draw a resection line.
3. Sight through  $b$  toward  $B$  and draw a resection line.
4. Sight through  $c$  toward  $C$  and draw a resection line.
5. Unless correctly oriented these three resection lines will form a triangle, known as the *triangle of error*.



FIG. 44.—Student orienting the Abrams sketch board.

6. If the point  $D$  is inside the triangle formed by  $ABC$ , the plotted position of  $d$  will be inside triangle of error.

7. If the point  $D$  is outside triangle  $ABC$ ,  $d$  will be outside the triangle of error.

8. If point  $D$  is on the circle connecting  $ABC$ , it will be impossible to locate  $d$  by this method.

9. By a few trials it will be possible to decrease the size of this triangle of error until it becomes a point that is the plotted position of  $d$ .

#### THE SKETCH BOARD

The sketch board is a small plane table, used primarily by the U.S. Marine Corps for making small topographic maps in the field.

It is mounted on any ordinary plane-table tripod and can easily be removed for making vertical shots in determining the percentage of slope between two objects. If a planimetric map only is required of an area, the sketch board is leveled over a control station and used as a plane table with an alidade for sketching. For making topographic sketches, we also need the elevation of points throughout the terrain, and these can be made approximately accurate by figuring the height produced by the difference of the slope between two objects. The Abrams sketch board has one side calibrated in slope in per cent for that purpose.

*Steps in determining elevations by use of a sketch board:*

1. Attach the plumb bob to the side of the sketch board opposite zero calibration on the per cent scale with a string somewhat longer than the board.



FIG. 45.—Determining slope by means of Abrams sketch board and a plumb bob.

2. Remove the sketch board from the tripod.
3. Hold the board perpendicular to the ground and sight along the top edge to the point of unknown elevation.

4. Read the percentage of slope that the plumb bob and string intersect on the scale.

5. Compute the elevation of the objective by the following formula:

Elevation of objective = (height of eye + elevation) + or - (horizontal distance  $\times$  percentage of slope)

*Example:*

Height of eye = 5 ft.

Elevation = 100 ft.

Horizontal distance = 100 ft.

Percentage of slope = +10 per cent slope

(5 ft. + 100 ft.) + (100 ft.  $\times$  10 per cent) = elevation of objective  
= 115 ft.

6. Many points of elevation can thus be found throughout the area mapped.

### TRIANGULATION

**Practical Application of the Elements of Surveying in the Field of Aerial Mapping.**—In the process of making charts and maps from aerial photographs, plane surveying plays a very important part in obtaining primary ground control and vertical control. Vertical control is obtained by running very accurate differential levels over the entire area, establishing bench marks at points that can be easily identified on the photographs. This vertical control should be tied in with an accurately established datum plane, U.S. Coast and Geodetic Survey datum plane if possible.

Primary control consists of a series of positions whose latitude and longitude are known. The coordinates ( $L$  and  $L$ ) of these positions can be plotted on a polyconic projection. The positions are usually triangulation stations, or, if enough of these are not available in the area, an accurate ground traverse can be laid out in the field. This traverse should be tied in with whatever triangulation stations are available. If none is available, we could accurately find the latitude and longitude of several points in the traverse by observing the sun for azimuth, latitude, and longitude.

**Triangulation.**—Triangulation is that branch of surveying which makes use of triangles and involves a minimum of distance measurement and a maximum of angular measurement, combined with a maximum of office computation.

Minor triangulation is sometimes necessary in engineering surveys where a distance across a wide body of water, deep canyon, or ravine must be found. Here direct measurement is impractical. A system of triangles with a measured base line, as shown in Fig. 46, will allow the calculation of the inaccessible distance.



The distance  $AB$  is the measured base. Set up the transit at  $A$  and read the angle  $BAC$  by repetition. Do the same at  $B$ . Then by the trigonometric law of sines

$$\frac{(C - B)}{\sin A} = \frac{(C - A)}{\sin B} = \frac{(A - B)}{\sin C}$$

we can find the length of sides  $A$  and  $B$ .

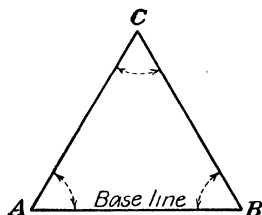

FIG. 46.

This method can be expanded. We could measure a base line accurately, and from each end of the base line, we could read the

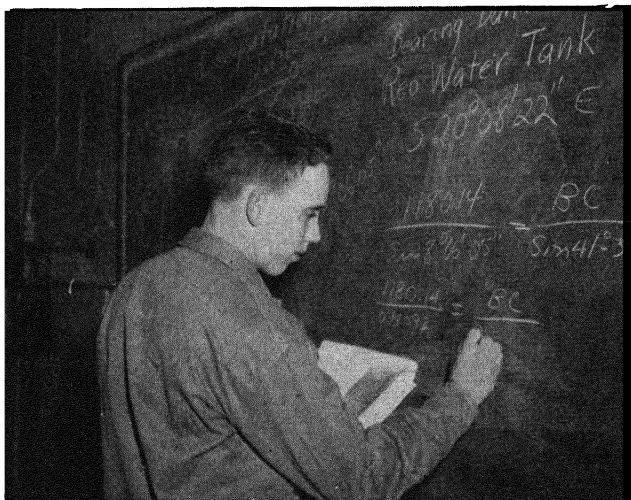
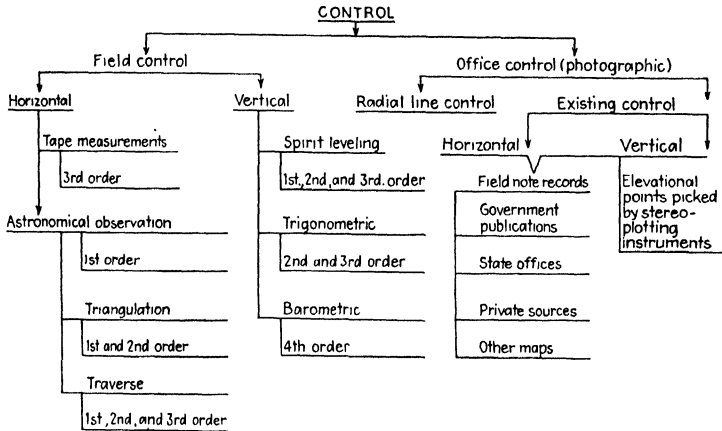

FIG. 47.—Using the trigonometric sine law to compute position.

angles to several previously established triangulation points (U.S. Coast and Geodetic Survey or U.S. Geological Survey). By solving the resultant triangles we could determine the bearing of the base line. This base line could then be made a line in our traverse, and we could continue our traversing, reading all angles (repetition). From our known bearing, we can compute the bearings of our entire

traverse; and, knowing the lengths of our traverse lines, it is possible to compute the  $x$  and  $y$  coordinates, (latitude and departure) of each traverse point.

Triangulation offers the cheapest and best method of controlling extensive surveys, particularly in rough country, but is seldom used



ORDERS OF ACCURACY

Class	Average triangle closure in triangulation horizontal	Allowable error of closure in feet	
		Horizontal	Vertical
1st order	1 second	1 to 25,000	0.017 $\sqrt{\text{length in miles}}$
2nd order	3 seconds	1 to 10,000	0.035 $\sqrt{\text{length in miles}}$
3rd order	5 seconds	1 to 5,000	0.050 $\sqrt{\text{length in miles}}$
4th order	more than 5 seconds	less than 1 to 5,000	greater than 0.050 $\sqrt{\text{length in miles}}$

FIG. 48.—Degrees of control. (From Bagley, "Acrophotography and Aerosurveying.")

for small areas, except where traversing is exceptionally difficult. The size of angles composing the triangles resulting from triangulation has a lot to do with the strength of the work. "Good practice" is to have all angles more than 30 and less than 120 deg.

Shown as illustrated problems in Forms 6 to 11 are several types of surveys used in connection with aerial mapping.

Also is included a summary sheet (Fig. 48) showing the types and limits of different degrees of control.

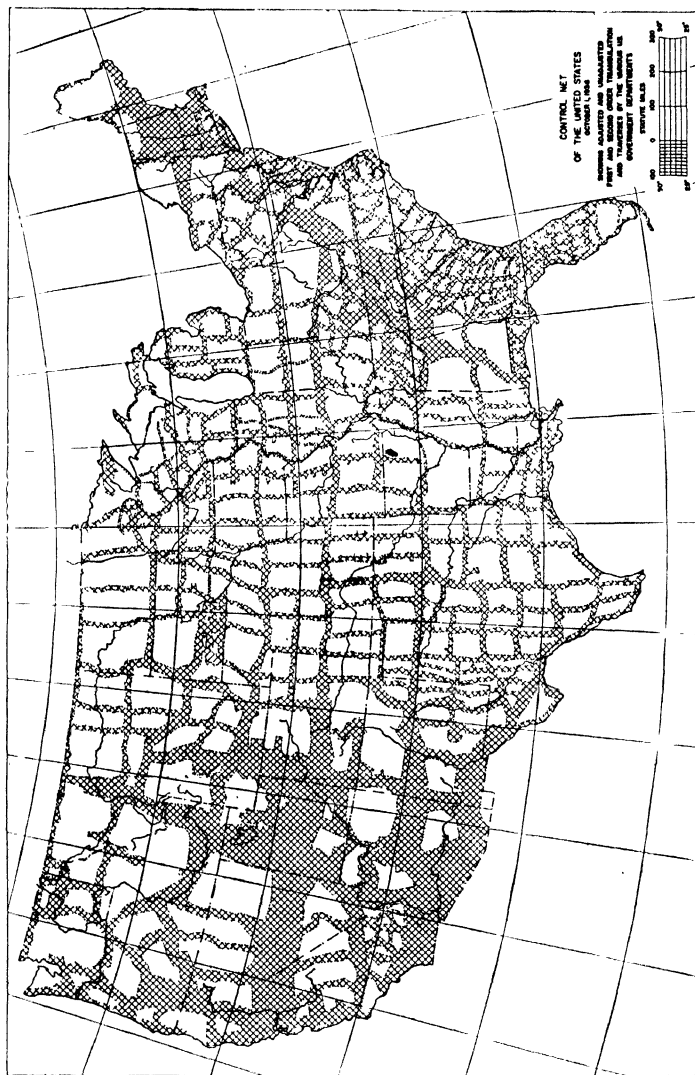
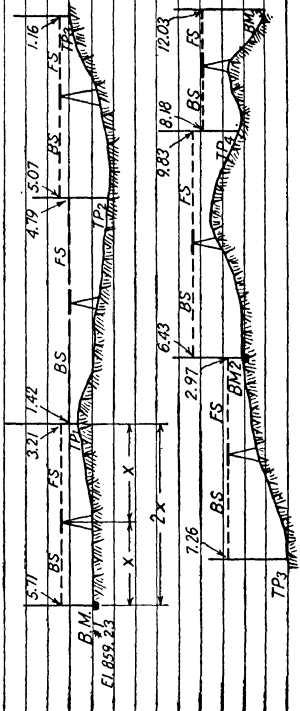

Fig. 49.—Entire network of the United States controlled by first- and second-order triangulation.

STA.	B. S.	H. I.	F. S.	ELEV.	DESCRIPTION	Level party No. 1 J E Doe - Chief
BM <sub>1</sub>	5.71	864.94		859.23	BM <sub>1</sub> - Top of valve stem - hydrant - corner Maple & Oak	
TP <sub>1</sub>	1.42	863.15	3.21	861.73		
TP <sub>2</sub>	5.07	863.43	4.79	858.36		
TP <sub>3</sub>	7.26	869.53	1.16	862.27		
BM <sub>2</sub>	6.43	872.99	2.97	866.56	BM <sub>2</sub> - Brass plate $\phi$ of intersection Mich. Ave. & Cedar St	
TP <sub>4</sub>	8.18	871.34	9.83	863.16		
BM <sub>3</sub>			12.03	859.31	BM <sub>3</sub> - + on S.W. corn of concrete platform M.C.R.R. Passenger Station	
Computation check						
Sum of BS = 34.07						
Sum of FS = 33.99						
$  \begin{array}{r}  \text{Final EL} = 859.31 \\  \text{Starting EL} = 859.23 \\  \hline  = .08  \end{array}  $						

Sketch illustrating level notes



FORM 6.

# 52 AERIAL SURVEYING AND PHOTO INTERPRETATION

Typical azimuth survey						Date
						Weather
						Party
						Equipment Location
						Remarks & sketch
Sta	Obj.	Dist.	Azi.	Mag. bear.	Comp. bear.	
1	5		260°29'	N80°30'W	S80°29'W	
	2	68.93	340°30'	N	N19°30'W	
2	1		160°30'	S	S19°30'W	
	3	50.97	293°05'	N48°W	N66°55'W	
3	2		113°05'	S48°15'E	S66°55'E	
	4	67.87	226°13'	S65°30'W	S46°13'W	
4	3		46°13'	N65°15'E	N46°13'E	
	5	57.25	167°58'	S7°W	S12°2'E	
5	3		347°58'	N7°15'E	N12°2'W	
	1	108.27	80°29'	S80°W	N80°29'E	

FORM 7.

Typical transit					Traverse	Notes	Date
All angles swung to left					Transit - 1 minute Berger		Weather - Cold
					Sight rods - 2		
					Chairs - 2 - 100 foot steel		
					Prism - 11		
					Party Names	Continuation May 1915 Day	Byron Dixon
Sta.	Hor. angle	Dist.	Mag. bear.	True bearing	12" Oak	Remarks	
B.S.					Sta. 21212	Blkg. cor	
A	103°55'	3303.9	N76°E	N76°40'E	12" Oak	Blkg. cor	
B	207°50'	3304.1			4" Maple	Mark of pavement	
A B							
C	139°18'	5732.95	S62°30'E				
	278°36'	5733.05					
B C							
D	69°34'	10006.0					
	139°08'	10006.0					
C D							
E	118°27'	1754.0					
	236°54'	1754.0					
					True bearing AB found by solar observation		

FORM 8.

Typical deflection					Angle	Traverse	Date
Closed traverse					Equipment		Weather
		Det.	Mag.	True or comp. bearing	Location		
Sta	Dist.	angle	bear		Party names		
A B	A to B	N18W	N18W		Sketch		
C	50.77	57°-54R	N39E	N39°-39'E			
B C							
D	78.47	113-38L	N73W	N73°-59W			
C D							
E	99.46	98°-15L					
D E							
F	73.97	88°-19L					
E A							
B	52.60	117°-43L					

FORM 9.

Typical stadia topographic survey						Date
Stadia constant 100						Weather
						Party
Sta.	Azi	Rod int.	R R	vert angle	Elev	Location
BM <sub>1</sub> - BS - 4.19		HI = 506.56			502.37	
A B	HI	$\pi$ at B = 506.56				Remarks
1	13°-47'	11.22	3.7	0°-00'		B.M. - Hydrant - cor Mich & Wash. Ave.
2	85°-06'	8.38	8.72	-4°-6'		Junc. Street & wall
3	123°-12'	10.57	11.86	-5°-15'		NW cor barn
4	178°-47'	4.32	3.21	+3°-05'		NE cor barn
5	358°-51'	6.87	1.16	0°-00'		Elevation point
C	283°-38'	10.50	4.19	0°-00'	502.37	"
B C	HI	$\pi$ at C = 502.57				
1	15°-6'	6.23'	3.7	0°-00'		Elevation point
2	29°-51'	8.79'	4.1	-1°-4'		"
3	196°-23'	4.28'	3.7	-3°-27'		Base of 12' oak - elevation point
4	208°-13'	9.16'	8.6	+4°-16'		& street intersection
D	226°-42'	8.42	9.2	0°-00'	496.37	Top V.S. City hydrant

FORM 10.

# 54 AERIAL SURVEYING AND PHOTO INTERPRETATION

Typical triangulation problem				Date
Sta	Erect	Invert		Weather - Cold
1	2			Readings on Vernier A
W.T.	75°30'			Transit - 30" Buff & Buff
"		50°00'30"		Sight rods 1
"	225°30'30"		Base line measurements	Chairs - 2 - 100 - Standardized 68°F - 12"
"		30°00'00"	1755.00	Pins - 11
"	16°30'30"		1754.89	
"		92°00'30"	1754.78	
R.T.	36°24'		1755.03	
"		72°48'30"	1755.12	
"		109°13'00"	1755.07	
"		145°37'00"	1755.10	
"		182°01'	1754.92	
"		218°25'30"	1754.95	
2	1		1755.00	
W.T.	39°48'30"		Av = 1754.00	
"		79°36'30"		Lat & long of inaccessible points are known. Bearing and distance between them can be found from Military Grid computations from Dep't of Com Spec Bulletin #59 - then by Trigonometric Law of Sines and Tangent Law can compute bearing of base which was the reason for doing work.
"		119°25'00"		
"		158°13'00"		
"		198°01'30"		
"		237°49'30"		
R.T.	92°10'30"			
"		184°21'00"		
"		276°31'30"		
"		8°42'00"		
"		100°52'00"		
"		102°02'00"		

FORM 11.

CHAPTER III  
MAPS AND GLOBES  
MAPS

Maps were first developed as a guide for men in their desire, through necessity or curiosity, to explore the earth's surface and to move from one part of the earth to another. A map is a graphic expression of the elements of distance and direction. The main object of cartography is to give graphic expression and permanency to these elements.

The idea of representing distance to scale underlies all maps. The determination and expression of distance is even more difficult than the determination and expression of direction, because some elementary knowledge of mathematics is essential before it can be attempted.

**Early Attempts at Orientation.**—No mathematical knowledge is required in indicating direction. Nature herself has solved the problem. The sun and stars by the regularity of their motions supply a natural beginning and end. Probably it was the rising sun that gave human beings their first notions about orientation. The primitive traveler took his bearings when he arose in the morning.

It was the Genoese seamen during the later centuries of the Middle Ages who established north as the starting point of the compass. They made their charts, called *portolano charts*, with the aid of the compass. This discovery of the use of the compass revolutionized maps, navigation, and cartography.

From the fourteenth century onward the chart makers' delight in the new discovery (the compass) is illustrated in the highly ornate "compass rose" adorning the charts of that period. Some of these charts give a veritable maze of lines going in 32 directions. Land maps rarely give more than four directions. In addition, both on land and sea, the declination is given, and the intensity and direction of this variation must also be indicated for travel by compass alone.

In 1532, the first printed chart showing the variation in the compass was made. In 1595, the angle between true north and magnetic north was first shown on a marine chart.

The actual method of representing true north on a map is a very interesting problem. In modern maps, a star or a fleur-de-lis is the



most common design. Generally speaking, the older the map, the more ornamental it is. About 1610, the first use of all four directions north, south, east, and west was made.

**Types of Map.**—There are now roughly three types of map.

*Atlas maps* are bound within the cover of a volume. They usually have scales less than 1 in. = 10 miles (fractional scale 1:633,600). A scale smaller than 1:500,000 is typical of atlas maps.

*Topographic maps* show by signs and symbols all the major and many of the minor features of the terrain covered. A typical scale is 1 in. = 1 mile (1:63,360). Fractional scales are usually less than 1:500,000 but larger than 1:10,000.

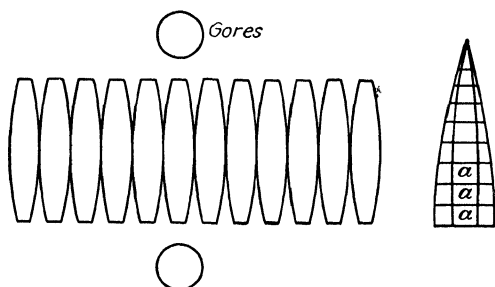

FIG. 50.—Construction of a globe.

*Cadastral maps, plans, and some other types of map* have scales larger than 6 in. = 1 mile (1:10,000).

A flat map must reproduce the curved surface of the earth as if it were flat. Thus the larger the area represented, the greater is the distortion. Globes, however, can show the correct sizes of countries and continents, oceans and their geographic relationships to each other, because a globe is a representation of the earth as if it were seen in miniature.

**Early Globes.**—The spherical form of the earth was recognized by the early Greeks, and they attempted to build a globe. They found that the known world would hardly fill a quadrant of the sphere and so they started to speculate about the other three-quarters. In about 150 B.C., they built a globe and tried to balance it by inserting three other balancing continents. This represents the first attempt to depict areas that are now called America and Australia.

The first terrestrial globe to survive was made in 1492, and America does not appear. After all the great discoveries of the fifteenth and sixteenth centuries, however, there seemed no better way to demonstrate the new geography than by this method. The early

Renaissance period is the golden age of globes. A globe made in 1515 showed the Strait of Magellan before it was discovered.

**Globe Construction.**—Globes are usually made from already printed globe gores, which are pasted on a suitable base, of pressed metal, wood, or papier mâché. Large globes are usually constructed on a wooden frame, upon which are applied layers of wood pulp and plaster of paris, strengthened with hair and glue. Some globe makers apply this mixture to the inside of a hemispherical mold. After this has hardened, it is taken out of the mold, and the halves are glued together at the equator. The surface is smoothed with plaster; and, after it has been polished, the gores are wetted and pasted on it.

There are usually 12 globe gores, each of which represents 30 deg. of longitude. The arctic and antarctic regions are frequently pasted on separately in round pieces.

**Globe Gores.**—Globe gores are usually drawn in a modified globular projection. The central meridian and the equator are divided evenly and truly but made smaller than the scale of the globe to allow for the expansion of the paper when wetting. Obviously the central meridian is shorter than the side meridians, and even these sides are less than on the globe. The difference is taken care of by proper wetting of the paper, more in the center and less on the sides. The polar pieces are drawn in a polar azimuthal equidistant projection.

**Accessories.**—Globes usually have a steel or wooden axis, around which they can be turned. The axis ends are attached to a meridian ring. The meridian ring can be supported at the bottom, attached to a fork, or suspended from above. In any case, both the ring and the globe can be made vertical or inclined  $23\frac{1}{2}$  deg. to show the inclination of the equator with the ecliptic.

**Global Relief.**—It is nearly impossible to show relief on a globe, as can be clearly seen in the following illustration.

1. Consider a globe 20 in. in diameter to represent a circumference of 8,000 miles. The scale then is 1 in. = 400 miles.

2. Suppose the highest mountain is 25,000 ft., which is about 5 miles.

3. The deepest ocean is about 3 miles.

4. The difference in extreme elevations is 8 miles.

5. To our scale 1 in. = 400 miles, this would equal 0.02 in., which is quite insignificant as far as a representation of relief is concerned.

## CHAPTER IV

### MAP PROJECTIONS

The connections between early man and his immediate surroundings were very intimate and soon attracted his attention, so that by the use of his imagination and intellect he began to conceive the idea of a plan or map, using his center of activity as the center of the map and relating his surroundings to a central point. The accuracy of his map therefore decreased as the distance from his center of activity increased. So too, in our present-day maps, we find it impossible to eliminate error completely.

**The Earth.**—We can safely assume that the earth is a sphere, or, more accurately stated, an oblate spheroid, with the polar diameter about 26 miles shorter than the equatorial diameter. For our purpose we shall consider the earth a sphere, the irregularities being small compared to the size of the earth. Since it is impossible to represent the surface of a sphere exactly upon a plane surface, some distortion and error cannot be avoided.

**Latitude and Longitude.**—Any point on a sphere is exactly like any other point, and there are no means of differentiation. On the earth it is necessary to have some points or lines of reference so that other points may be located. Latitude and longitude are used for this purpose.

The earth rotates once a day on its axis, which is therefore a definite line different from every other diameter of the earth. The ends of this diameter are called the *poles*, one the North Pole and the other the South Pole.

With this as a starting point, the sphere is divided into two hemispheres by a plane perpendicular to the axis midway between the poles. The point at which this plane would pierce the earth is a great circle called the *equator*. Any circle that divides the earth into two equal parts is called a *great circle*. Each great circle is divided into 360 equal parts, each part being called a *degree*, each degree being subdivided into 60 parts called *minutes*, and each minute being divided into 60 parts called *seconds*.

Now, drawing great circles that pass through the poles and intersect the equator, we have lines called *meridians*. These great circles are divided into four equal parts called *quadrants*, each

quadrant extending from the equator to a pole. Each quadrant is divided into 90 equal parts, or degrees, and these are designated from 0 degrees at the equator to 90 degrees at the poles. Taking a point in one of these quadrants and passing through this point a plane perpendicular to the axis, we form a circle parallel to the equator. This lesser circle is called a *parallel* and is given a designation with reference to the equator in terms of latitude, latitude 0 degrees being the equator; latitude 90 degrees north ( $90^{\circ}\text{N.}$ ), the North Pole; latitude 90 degrees south ( $90^{\circ}\text{S.}$ ), the South Pole.

The meridian passing through Greenwich Observatory, England, is given the designation of longitude 0 degrees, and the meridians therefore number 0 to 180 degrees east and west of the Greenwich meridian.

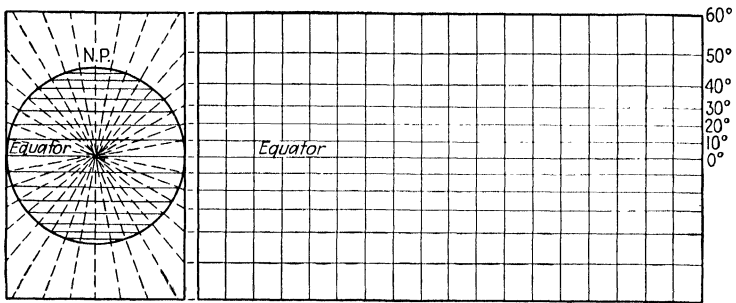

FIG. 51.—Cylindrical projection.

**Developable Surfaces.**—Having imaginary lines on the earth's surface, we can now proceed to transform them to a plane surface.

It being impossible to reproduce the surface of a sphere on a plane surface without stretching or tearing the surface, we find it necessary to transfer the lines of longitude and latitude to a more easily developable surface. A developable surface may be termed one that is easily transformed or developed into a plane surface. Two of the most common are a cone and a cylinder. When a cone is cut from its apex to its base, it can readily be spread onto a plane surface. A cylinder can be cut from one rim to the other and spread onto a flat surface.

**Cylindrical Development of the Sphere.**—To apply the cylinder as a means of projecting the lines from the sphere, we can proceed in two ways. First, placing a cylinder over the earth, tangent at the equator, project the lines from the center of the earth through the surface onto the cylinder. We find it impossible to project the areas around the poles onto the cylinder, and the upper latitudes are therefore omitted in this type of projection. In Fig. 51 it will

be noted that lines of latitude and longitude are represented by the straight lines perpendicular to one another.

The only true portion of this cylindrical projection is the area tangent to the sphere at the equator. Distortion increases north and south of the equator.

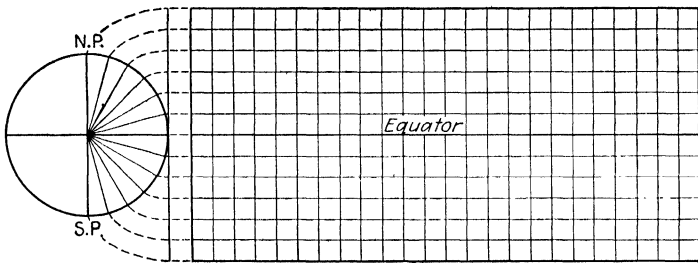

FIG. 52.—Cylindrical equally spaced projection.

Another type of cylindrical projection is one in which the spacing of the latitudes is determined by their proper spacing on the globe. The width of the projection is one-half the circumference of the globe. The meridians are equally spaced or kept to a uniform spacing by

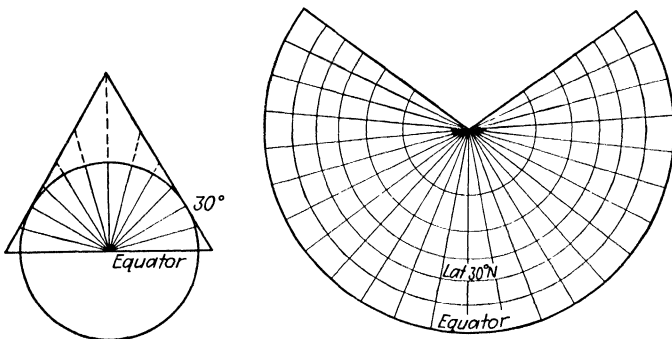

FIG. 53.—Conical projection.

making them all the same as at the point of tangency. As in any projection of this type, the distortion increases toward the polar regions.

**Conical Projections.**—The most popular of our developable surfaces for map projection is the cone. Its popularity arises from the fact that upon a globe the meridians converge at the poles. By placing a cone over the globe, we can use the apex of the cone to represent our poles, thereby giving the projection a closer fit to the globe. The lines of latitude and longitude are projected from the

center of the earth through the surface of the globe and extended upon the cone. Figure 53 is a simple conical projection. The distortion increases as we proceed north or south of the point of tangency. In a conical projection, the meridians converge at the pole and are represented by straight lines. The parallels of latitude are parallel to one another and are curved lines. All distances would be true only on the 30-degree parallel.

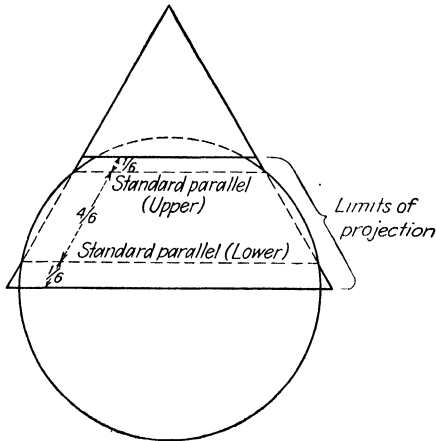

FIG. 54.—Conical projection.

**Conformal Conic Projection.**—One method of reducing error or perhaps neutralizing error to some extent in a conic projection employs the use of a cone tangent at two standard parallels or, as it has been expressed, as a projection upon a secant cone (see Fig. 54). In this type of projection the distortion is held to an average. The territory between the standard parallels would be under scale with a scale increase appearing in the remainder of the projection. The proper spacing of the standard parallels to fit any one projection is one-sixth and five-sixths of the total length of that portion of the central meridian to be represented.

On the two parallels selected, arcs of longitude are represented in their exact scale. Meridians are represented by straight lines converging to a point beyond the limits of the projection. This projection is particularly suited to an area with a predominant east and west dimension. Scale error in a projection the size of the United States does not exceed  $2\frac{1}{2}$  per cent.

**Polyconic Projection.**—Several methods have been employed to eliminate as much as possible the error in a conic projection. One method was built on a series of cones. In place of one cone tangent

at one parallel, a new cone was developed for each parallel for even degrees of latitude, and the name *polyconic* (meaning many cones) projection was applied. The polyconic projection is a combination of the various good features of all the conic projections and has many advantages over other types of projections. There is ease of construction and only slight error if it is not carried to any great extent in an east and west direction. Its accuracy is not affected by extension in a north or south direction. In the polyconic projection the central meridian is represented by a straight line, and the parallels are represented by arcs of circles that are not concentric but the centers of which all lie in the extension of the central meridian. The distances between the parallels are made proportional to the true distances on the earth.

The great advantage in the polyconic projection is that a set of tables can be computed for use on any part of the earth. Error is held to a minimum in a north and south dimension, and areas should be limited in east to west extent. In a projection the size of the United States the maximum scale error does not exceed 7 per cent.

TABLE I.—TERRESTRIAL ARCS

Latitude	Latitude 40 to 41°—meridional arcs						Latitude 40°—coordinates of curvature for the polyconic projection		
	Value of 1"	Sums of seconds for middle latitude 40°30'		Value of 1"	Continuous sums of minutes from latitude 40°00'		Longitude	X	Y
		Meters	Sec- onds		Meters	Meters			
° ' "	Meters	Sec- onds	Meters	Meters	Min- utes	Meters	° ' "	Meters	Meters
40 00	30.842	..	.....	1850.54					
40 01	30.842	1	30.85	1850.55	1	1850.5	0 1	1423.4	0.1
40 02	30.842	2	61.69	1850.56	2	3701.1	0 2	2846.5	0.5
40 03	30.842	3	92.54	1850.56	3	5551.7	0 3	4269.8	1.2

The U.S. Coast and Geodetic Survey has compiled a Table for a Polyconic Projection of Maps, *Special Publication 5*, in which are contained lengths of terrestrial arcs of meridians and parallels. The lengths of meridians and parallels are given in meters at sea level. Lengths of meridians are to be found under Continuous

sums of minutes. Lengths of arcs of parallels are expressed in terms of coordinates. The X coordinates represent measurement east or west of the central meridian and the Y coordinates represent measurement north or south of the construction line.

*Steps in the construction of a polyconic projection:*

1. The making of a data sheet to be used in the construction will include latitudinal distance on the central meridian of the projection and X and Y coordinates for the plotting of longitudinal distances in arcs of parallels.

*Example of Data Sheet.*

Latitudinal distances				Longitudinal distances			
From	To	Meters ground distance	Inches on map	At latitude	Longitudinal distance	Meters ground distance	Coordinates of curvature
40°00'	40°15'	27,758.8	27.32	40°00'	15'	x = 21,349.0	21.01
	40°30'	55,518.8	54.64			y = 29.9	
				40°15'	15'	x = 21,270.3 x = 29.95	20.94 0.03
				40°30'	15'	x = 21,191.7 y = 30.0	20.86 0.03

This information is available in the afore-mentioned bulletins. The latitudinal distances are available under continuous sums of minutes. Interpolation will be necessary for distances not of equal 1-minute intervals. Longitudinal distances are located under coordinates of curvature in the last three columns and are listed for even degrees of latitude. Coordinates of curvature are measured from the central meridian in an east and west direction, the central meridian being used as zero. For conversion of ground distance in meters to map distance in inches, multiply ground distance by 39.37 (conversion of meters to inches), and divide by the denominator of the scale fraction.

2. Erect a straight line north and south and in the center of the board to be used as the central meridian of the projection.

3. Plot measurements for the latitudinal distance on the central meridian to the closest hundredth of an inch.



4. Erect lines perpendicular to the central meridian and intersecting points of latitudinal distance plotted on the central meridian. These lines are to be used as construction lines for the arcs of parallel.

5. Referring to longitudinal measurements on the data sheet, plot X coordinates east and west of the central meridian on the

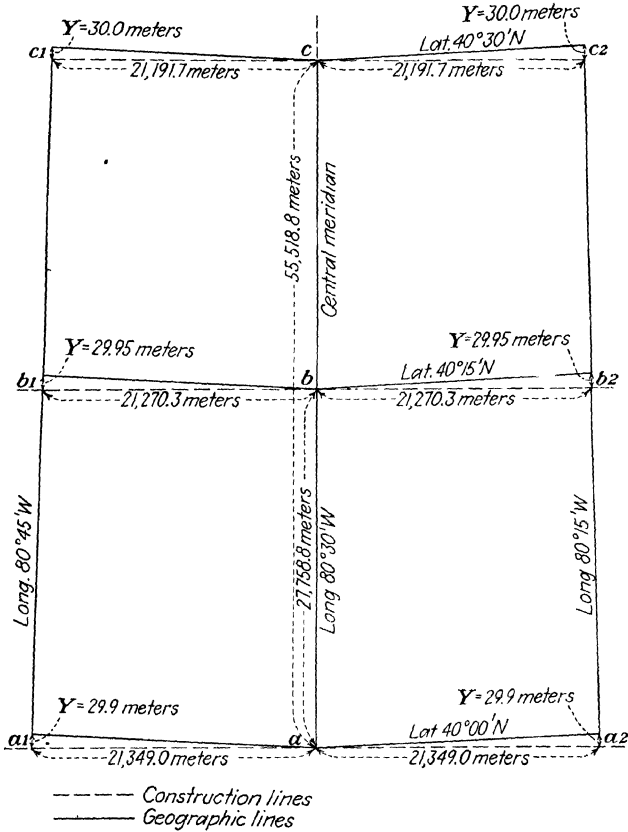

FIG. 55.—Polyconic projection.

construction lines; and, at every point where an X coordinate is plotted, measure a Y coordinate in the direction of increasing latitude (north or south). Then connecting these points, north and south, east and west, will result in meridians and arcs of parallel.

6. Label the lines of latitude and longitude, and the projection is complete.

*Example.* In the construction of a polyconic projection bounded by latitudes  $40^{\circ}00'N$ . and  $40^{\circ}30'N$ . and longitudes  $80^{\circ}15'W$ . and  $80^{\circ}45'W$ .

at a scale of 1:40,000, illustrated in Fig. 55, we should begin by filling in our data sheet. We refer to *Special Publication 5* on page 91 under the heading Latitude 40° to 41° Meridional Arcs, Continuous Sums of Minutes from Latitude 40°00'. We want 15-minute intersections on the projection. From 40°00' to 40°15' the distance in meters is 27,758.8, which is placed on our data sheet, and it represents the actual ground distance. Changing this to inches at our map scale:

$$\frac{27,758.8 \times 39.37}{40,000} = 27.32 \text{ in.}$$

We insert this in our data sheet under Coordinates of curvature. From 40°00' to 40°30' the distance in meters is 55,518.8, which, changed to inches at map scale, is

$$\frac{55,518.8 \times 39.37}{40,000} = 54.64 \text{ in.}$$

For the longitudinal measurements or the arc of parallel in the right-hand column under Coordinates of curvature, desiring a 15-minute interval from the central meridian east and west, we find, under the heading Longitude, directly to the left of 0°15' the X coordinate is 21,349.0 meters, the Y coordinate 29.9 meters. Changing to inches at map scale:

$$X = \frac{21,349.0 \times 39.37}{40,000} = 21.01 \text{ in.}$$

$$Y = \frac{29.9 \times 39.37}{40,000} = 0.029, \text{ or } 0.03 \text{ in.}$$

X = 21.01 in. represents a measurement to east and west on the construction line at the lower limit of our projection, and Y = 0.03 in. is the amount of lift or curve to the parallel of 40°00'. The tables being computed for parallels of only even 1-deg. intervals, it becomes necessary to interpolate for longitudinal measurements on parallel 40°15' and 40°30'. Interpolating between latitude 40°(page 91) and latitude 41°(page 93) for 0°15', we have:

At latitude 40° for 15',	X = 21,349.0 meters
At latitude 41° for 15',	X = 21,034.3 meters
Subtract the difference	314.7 meters

Using our proportion of the degree to the desired parallel 40°15', or  $\frac{15}{60}$  of the difference

$$\begin{aligned} 15:60::x:314.7 \\ x = 78.7 \text{ meters} \\ \text{Then } 21,349.0 \text{ meters} \\ - \quad 78.7 \text{ meters} \\ x = 21,270.3 \text{ meters} \end{aligned}$$

The X coordinate on the 40°15' parallel = 21,270.3 meters. Changing to inches at map scale

$$\frac{21,270.3 \times 39.37}{40,000} = 20.94 \text{ in}$$

The Y coordinate is computed as follows:

$$Y = \frac{29.95 \times 39.37}{40,000} = 0.03 \text{ in}$$

On the parallel 40°30' our proportion would be

$$\begin{aligned} \frac{30}{60} &\text{ or } 30:60::x:314.7 \\ x &= 157.3 \\ \text{Then } 21,349.0 &\text{ meters} \\ - 157.3 &\text{ meters} \\ \hline &21,191.7 \text{ meters} \end{aligned}$$

The  $X$  coordinate on the 40°30' parallel = 21,191.7 meters. Changing to inches at map scale

$$\frac{21,191.7 \times 39.37}{40,000} = 20.86 \text{ in.}$$

The  $Y$  coordinate is computed as follows:

$$Y = \frac{30.00 \times 39.37}{40,000} = 0.03 \text{ in.}$$

Procure a board large enough to receive the projection. With the use of a straightedge, draw a line down the center of the length of the board. This will be our central meridian. Choose a point near the end of the board and on the central meridian to be used as the intersection of the central meridian and latitude 40°00'N. From the data sheet secure the latitudinal measurements at the map scale, and plot them on the central meridian (see  $a$  to  $b$  and  $a$  to  $c$  in Fig. 55).

Then erect lines ( $a1-a2$ ), ( $b1-b2$ ), ( $c1-c2$ ) in Fig. 55 perpendicular to the central meridian and intersecting points  $a$ ,  $b$ , and  $c$ . These will be used as construction lines for our arcs of parallel.

Plot  $X$  coordinates on their respective construction lines, thence the  $Y$  coordinate from the extremity of the  $X$  coordinate in the direction of increasing latitude. From this point, draw a straight line to the corresponding line on the central meridian. Also join with a straight line the three extremities of the arcs of parallel, and from the outer meridians. The central meridian is coincident with the construction line and can therefore be used on a geographic line.

Ink the projection with waterproof ink. Label all the lines of longitude and latitude, and the projection is complete.

**Interrelated Projections.**—There are three interrelated projections in common use today. They are the Lambert conformal, the Mercator, and the stereographic polar projection. These three projections are conformal projections, and the last two may be considered special cases of the Lambert. When the tangent cone of the Lambert becomes a tangent plane at the pole, we have a stereographic projection. When the parallel of tangency approaches the equator, the Lambert merges into the Mercator projection.

The stereographic projection of the Northern Hemisphere when projected, obtains its point of projection at the South Pole. The plane upon which the projection is taken is generally the equatorial plane, but a plane tangent at the North Pole can be used equally well, the only difference being in scale. On this projection the lines are drawn for 10 deg. in both latitude and longitude; and it

can be seen that, were we to project each one of these circles separately and reduce them all to a common scale, they would fit almost perfectly together with only a slight compression of the inner part of each circle. For larger scales, a 1-deg. interval between parallels would increase the accuracy and distribute the compression more equally over the entire projection.

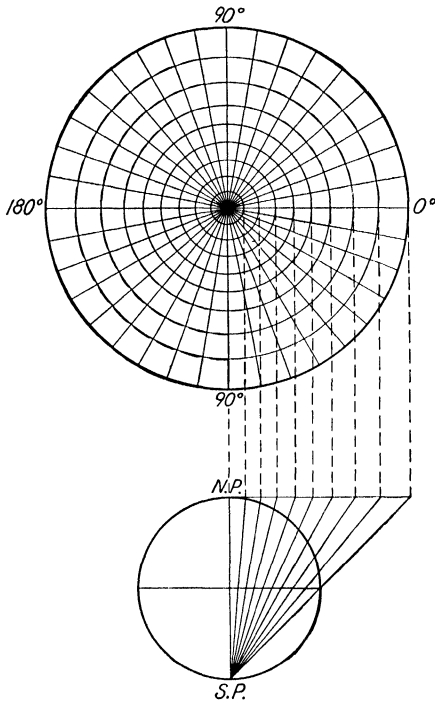

FIG. 56.—Determination of radii and construction of a stereographic projection.

In the Mercator projection, the distortion increases in the polar latitude. By using it in the equatorial regions alone, error due to convergence of the meridians may be held to a minimum. The Mercator projection employs a central meridian and a central parallel. The meridians are equally spaced and parallel, and the parallels of latitude increase in interval toward the poles.

The advantage of the Mercator projection is that a rhumb line is plotted as a straight line, and the bearing between two points can be taken directly from the chart. The track of the great circle would be a curved line and fall to the polar side of the rhumb line.

TABLE II.—TYPES OF CONSTRUCTABLE PROJECTIONS

Projections	Parallels	Meridians	Merit	Use
Rectangular	Horizontal—spaced equally at true distance	Vertical—spaced equally. True on standard parallel	Easy to construct	City maps Less exact maps
Mercator	Horizontal—spaced more closely near poles	Vertical—spaced equally. True on equator	Straight rhumb lines	Charts World maps
Sinusoidal	Horizontal—spaced equally at true distance	Sine curves—spaced equally on each parallel	Equal area	World maps Tropics
Mollweide	Horizontal—closer near poles	Ellipses—spaced equally. True on equator	Equal area	World maps Hemispheres
Eckert	Horizontal—closer. Near poles lines are $\frac{1}{2}$ length at equator	Sine curves—spaced equally. True on equator	Equal area	World maps
Conic	Concentric circles—spaced equally	Radiating straight lines—spaced equally. True on 1 or 2 parallels	Small distortion	Mid-latitudes Series maps
Albers	Concentric circles—closer at north and south ends	Radiating straight lines. Equal on standard parallel	Equal area	Maps of the United States
Lambert conic conformal	Concentric circles—spaced more widely at north and south ends	Radiating straight lines. Equal on standard parallel	Orthomorphic	Maps of the United States
Bonne	Concentric circles—equal at all distances	Curves—spaced equally. True on each parallel	Equal area	Mid-latitude
Polyconic	Nonconcentric circles true on central meridian	Curves—spaced equally. True on each parallel	Tables available	Topographic sheets
Globular	Nonconcentric circles—spaced equally on periphery	Circles—spaced true on equator	Easy to construct	Hemisphere
Stereographic	Nonconcentric circles—closer near center	Circles—closer near center	Orthomorphic	Hemisphere
Orthographic	Ellipses—equal on periphery	Ellipses—spaced equally. True on periphery	Visual	World continents
Lambert's azimuthal	Curves—equal on periphery	Curves at varying distances	Equal area	World continents

## CHAPTER V

### ORIENTATION AND LOCATION

**Definition.**—The word *orientation* means the accurate location of control points and the establishment of lines of known length and direction on the face of the earth. *To orient* means to arrange surveying and observing instruments or azimuth-indicating devices on guns in such a manner that a line on the map or chart will be parallel to the same line in the field, or to make it possible to read the correct azimuth when the axis of the line of sight is pointed at the azimuth.

**Application.**—In its relation to surveying and military problems, orientation includes:

1. Determination of true north by one of several methods.
2. Determination of coordinates of a starting point and other important positions.
3. Establishment of base lines—reference planes.

**Use and Users.**—The surveyor is interested in proper orientation so that he can arrange his work on a map, making directions on the map parallel to the same directions on the ground. The trapper, timber cruiser, woodsman, and fisherman are interested in knowing their proper direction, hence their wide use of the compass to tell them magnetic north. Military unit commanders are directly charged with the proper orientation of the elements of their command. Each commander may have a staff officer specially trained as an orientation specialist. This specialist could be called a *reconnaissance officer*.

The battalion orientation officer has to determine the coordinates and orienting azimuth of all observing stations and possible targets, while the battery orientation officer has to orient properly his plotting board, observing instruments, fire-control instruments, and the guns of his own battery.

**Instruments Used.**—The job of orienting involves the use of many surveying instruments, with which the orienting officer or surveyor must be very familiar. They include:

- Transit and tape.
- Compass.
- Plane table and alidade.
- Stadia rod.

Level and level rod.

Hand level.

Tables of angle functions and grid coordinates.

**Orientation of Maps.**—Any project or operation, no matter what the size may be, that involves a coordination of movement and employment of groups of men and equipment requires the use of a map. The more involved the operation is, the more precise and detailed the map must be. In peacetime, this may be a sketch indicating a meeting place for a hunting party, or it may be an elaborate map of a railroad system. Only organizations involving transportation use a map more than the military forces do.

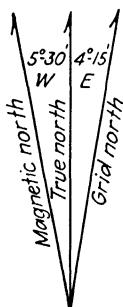

FIG. 57.—Indication on a map of magnetic, true, and grid north. Note the magnetic declination of  $5^{\circ}30' W$ . (needle pulled left of true north), also the grid declination of  $4^{\circ}15' E$ . (where grid north is east of true north).

A map is of course not of much use to any organization or individual unless it gives the needed information. The primary thing a map must do is to tell us how far and in what direction we have to go, and over what kind of terrain we must pass. We can gather knowledge of the terrain if we are familiar with and can read and interpret the difference topographic details as represented on the map. However, in order to find out the distance and direction we must travel, we must be able to study the location of the important points on the map. The map must therefore be in its correct position so that directions on the map are parallel to the same directions on the ground. This is the reason for orientation.

**North. General.**—All maps have the meridian of magnetic north or true north indicated on them by means of an arrow or compass rose, and all complete maps for military purposes have magnetic, true, and grid north clearly shown, as in Fig. 57.

*Magnetic north* is the direction in which the compass needle points when allowed to swing freely and unaffected by any local attraction. This direction changes periodically, and from place to place, and the amount of the change has been called *declination*. As explained in Chap. II, an isogonic chart should be consulted for values of declination. Chances for local attraction should be eliminated, as shown by Table III.

*True north* means the direction of the North Pole from the observer; and since true meridians converge on the pole, true north is not the same for all locations.

*Grid North.*—The grid lines have a direction known as grid north, and it is the direction in which the north-south grid lines point.

The amount of grid declination is the angle between true north of the projection and grid north. It becomes true north on the principal meridian of each zone.

TABLE III.—SAFE DISTANCES TO MAINTAIN BETWEEN A COMPASS AND AN ATTRACTING SUBSTANCE

	Minimum Distance, Feet
Power lines.....	500
Heavy gun emplacement.....	200
Telegraph and telephone wires.....	150
Wire fence.....	30

**Determination of True North.**—In Chap. II, methods of determining true north by means of surveying instruments were illustrated, but there are other approximate methods that also have a place in the discussion of orientation:

*By Means of a Pocket Watch and the Sun.*—For the Northern Hemisphere hold the watch in the hand with the dial up. Point the hour hand toward the sun, and bisect the smaller angle between

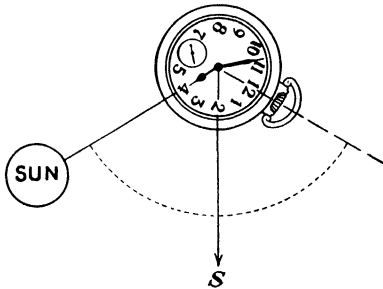

FIG. 58.

the hour hand and the number 12 on the dial. This bisecting line extended indicates a south line, and if you turned and faced in the opposite direction of this bisecting line, you would be looking north, with an error of approximately 5 deg. (see Fig. 58).

For the Southern Hemisphere the method is the same as in the Northern Hemisphere, but the watch must be held face down and this bisecting line will point north. This method is of very little use in the tropics when the sun is high.

*By the Rising and Setting of a Celestial Body.*—Measure with a compass the magnetic azimuth of the sun or a star at rising and setting (Fig. 59). Add these two azimuths and subtract the sum from 360 deg.; one-half of this difference is the declination of the compass needle. If the sum of the azimuths is less than 360 deg.,



the declination is an east declination; if the sum is greater than 360 deg., the declination is west as follows:

Magnetic azimuth of rising sun	108°
Magnetic azimuth of setting sun	253°
Sum	361°
	-360°
Difference =	1°
Quotient (÷ 2)	½°
Magnetic declination =	½°W.

**Orientation by Direction.** *By Compass When Magnetic North Is Shown.*—Lay map on a flat surface and place open compass along the magnetic meridian line drawn on the map. Turn the map and

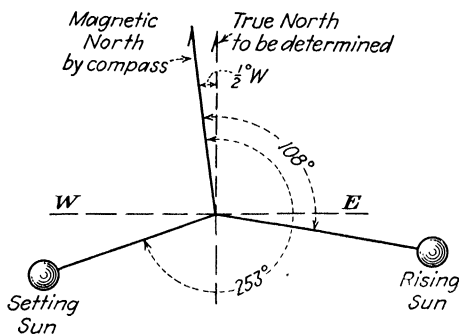

FIG. 59.

compass until the needle points toward the magnetic north, and the map is oriented.

*By Compass When No Actual Meridian Is Indicated but When Grid Lines Are Drawn.*—Lay the open compass on the map, line it up with a grid line, and rotate map and compass until the reading of the compass needle is equal to the grid declination.

*By means of a distant point,* when the observer's position is known. Select some distant object that can be identified on the map; then draw a pencil line through the symbol representing the distant object and the map position of the observer, and rotate the map until the line on the map points toward the distant object.

**Determination of Position.**—The above-mentioned methods apply to the job of orienting a map. The next job of importance is to find one's position on a map after it is oriented. The methods involve a knowledge of surveying and of the several systems of coordinates.

TABLE IV.—KINDS OF COORDINATE

Name	Kind	Elements	Starting point	Base direction	Units of measure	Use
Polar.....	Relative	One distance, one direction	Survey monument	True north, magnetic north, grid north	Feet, yards, miles, angles in degrees	Locates with protractor
Rectangular...	Relative	Two distances, one measured, from one point	Survey monument	True north, magnetic north, grid north	Feet, yards, miles	Locates without protractor
Geographic....	Absolute	Distances along meridians and parallels	Intersection of Greenwich meridian and equator	True north	Degrees and minutes of arc	Shows position of large indefinite area
Grid.....	Absolute	Zones, two distances, from one point	1,000,000 yd. west, 2,000,000 yd. south of intersection of central meridian and latitude 40°30'N.	Grid north	1,000-yd. units	Military maps

*Surveying Methods.*—The surveying methods are explained in Chap. II but will be briefly repeated at this time.

1. Traversing from a single known point. This method is similar to plane-table work, and is used in the sketch-board method of mapping.

2. Resection—plane-table or sketch-board method.

3. Intersection—use of inaccessible points.

4. Three-point problems—Lehmann's method.

*Coordinates.*—There are four kinds of coordinates in popular use today. Table IV gives their characteristics:

This study of the location of points involves the use of the relative and absolute coordinates.

*Relative* means the position of a coordinate with respect to some previously established survey point easily identified on the ground.

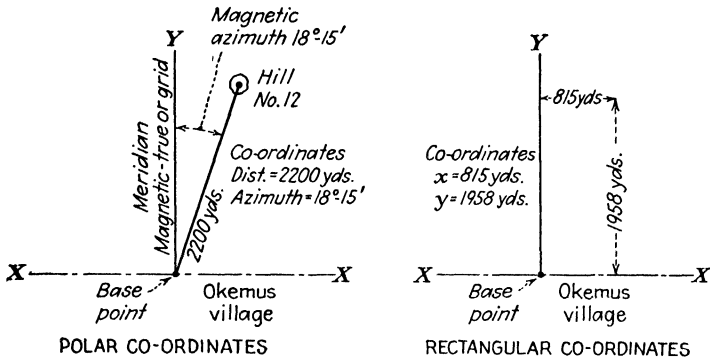

FIG. 60.

*Absolute* means the position of a coordinate with respect to a definite point, the intersection of the prime meridian through Greenwich, England, and the equator.

In order to express an absolute or relative position on a map or on a terrain, one of the previously mentioned system of coordinates must be used.

*Polar and rectangular coordinates* are called relative coordinates because they are determined by reference to base points and directions local to some map and are selected by some one person. Thus an indefinite number of polar and rectangular coordinate values could be assigned any one point (see Fig. 60).

*Methods of Plotting.*—In plotting polar coordinates, we use a scale to measure distance, and a protractor to measure the angle to be laid off. With the rectangular coordinates, we lay off computed dis-

tances along mutually perpendicular lines that are drawn through the base or starting point (see Fig. 60).

*Geographic and grid coordinates* are called absolute because each is determined with reference to one permanent fixed base point. Thus only one set of these coordinates for any point can be found.

*Geographic Coordinates.*—Latitude and longitude represent a spherical grid on the earth. Distances are measured in degrees; but, as the meridians converge, the units of longitude decrease in units of linear distance from the maximum at the equator to zero at the poles.

*Grid Coordinates.*—Units of 1,000 yd. each are measured east and west, north and south from mutually perpendicular lines.

*Plotting of the Geographic Position.*—The location of any point on the surface of the earth is defined in terms of the parallel of latitude and the meridian of longitude that intersect at the point, e.g., latitude  $180^{\circ}15'N$ . longitude  $67^{\circ}35'W$ .

*To determine geographic coordinates of a map position:*

1. Inspect the map, and identify the quadrangle in which the point lies. If the quadrangle is not drawn on the map, we can readily draw it in, because the values in degrees and minutes of the meridians and parallels that form this quadrangle appear on the margins of the map. The job is to determine the position of the point within the quadrangle (see Fig. 61).

2. Use the engineer's scale as a scale of proportional parts. The engineer's scale is used as a diagonal. If a grid is based on 1-minute divisions, and the geographical coordinates of a point are in seconds, the scale should be placed across the lines at some angle so that 60 convenient scale divisions span the distance; but remember the scale must pass through the point whose coordinates are wanted. The number of seconds to be read can now be found directly on the edge of the scale at the point in the direction of increasing grid values within the quadrangle. This value, added to the recorded value in degrees, minutes, and seconds of the lower sides of the quadrangle, will give the coordinate value of the point in question.

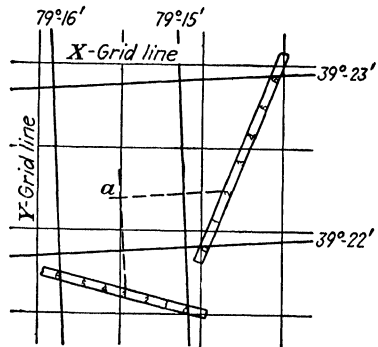

FIG. 61.—Determining geographic coordinates of a point.

*To plot the position of a point whose latitude and longitude are known:*

1. Find on the map the latitude and longitude lines nearest to and on each side of the point in question.
2. Now divide the quadrangle so formed into seconds of longitude and latitude.
3. One of these divisions will fall on the meridian of longitude, and another on the parallel of latitude through the point. The significant meridian and parallel are now struck off; and their intersection locates the point.

$$\begin{aligned}\text{Latitude point } a &= 39^{\circ}22'20'' \\ \text{Longitude point } a &= 79^{\circ}15'30''\end{aligned}$$

**Military Grid System.** *Application to Polyconic Projection.*—The length and direction of a line joining two points can be computed from their geographic or absolute coordinates, but the process is long and tedious. In a system of rectangular coordinates, however, if the abscissas  $X$  and coordinates  $Y$  of two points are known, the determination of the length and direction of the line joining them requires only the solution of a right-angle triangle. Likewise, in such a system, the position of a point may be determined if the distance of the point from two reference lines intersecting at right angles is known. The distances that locate the point are measured parallel to the horizontal and vertical axes and known as the  $X$  and  $Y$  coordinates.

For this reason a system of rectangular coordinates, known as the military grid system, has been adopted as a standard for all military maps. But, if this grid was used over the entire United States, it would be of no more value to us than a map on the polyconic projection. There would be too much distortion in the east and west directions. However, by limiting any one projection to about 9 deg. of longitude, the maximum distortion along the edge of the projection never exceeds 2.57 yd. per 1,000 or one-fourth of 1 per cent.

*Zones.*—For the purpose of superimposing the rectangular grid, the northern half of the continental Western Hemisphere has been divided into seven zones of 9 deg. each. Each zone is a separate polyconic projection. When it was first established, it extended from 28°N. to 49°N. latitude. This system, known as the continental system, was sufficient for the continental United States only. Later, in order to take care of Panama and the Caribbean area, the equatorial system extending from 7°N. to 28°N. was set up.

*Origin of Coordinates.*—In the polyconic projection of each zone, the origin of coordinates for the military grid is the intersection of the central meridian and the parallel of latitude 40°30'N. The central

meridian is the  $Y$  axis; and a line perpendicular to the central meridian, tangent to the parallel  $40^{\circ}30'N.$  latitude at the intersection of the central meridian, is the  $X$  axis. In terms of yards, the grid coordinates of all 5-minute intersections of latitude and longitude within the whole grid zone are computed with respect to these axes and this origin. The coordinates of intersections in all other quadrants except the first involve some negative quantities that are undesirable. In order to make positive all coordinates that appear on military maps embraced within the zone, the coordinates of the origin are  $X = 1,000,000$ ,  $Y = 2,000,000$ . The  $X$  coordinates extend from 600,000 to 1,400,000 in any one zone. Thus there will never be a negative  $X$  coordinate. The values of the  $Y$  coordinate vary from 500,000 at the Gulf of Mexico, to 3,000,000 at the Canadian border. Thus there never will be a negative  $Y$ , the zero for  $Y$  being somewhere below Florida.

The equatorial system has the same system of  $X$  coordinates, but its origin of  $Y$  coordinates is at the equator.

*Overlapping Zones.*—To avoid the confusion that would result when operating in areas lying in two adjacent zones, zones overlap one another by 1 deg.; and any map that falls within the 1-deg. overlap always shows in black lines the grid of the zone to which the map pertains. The grid of the adjacent zones will be indicated by tick marks in the margin.

*Military Maps.*—You can readily see that a complete zone covers an enormous territory (800,000 yd. east and west by 2,500,000 yd. north and south). Special military and artillery maps (fire-control maps), are all of the same size, 6,000 by 10,000 yd. It is very important that each map be given the letter of the zone it is in. Immediately following should be the coordinates of the southwest corner of the map. Since they are all of the same size, it is not necessary to give the entire coordinate, *e.g.*, if in zone  $A$ , the  $X$  and  $Y$  coordinates of the southwest corner of a map (fire control) are 1,160,000, and 2,292,000, the designation of the map will be A1160.-2292. Each fire-control map will be given the name of some prominent point on the map.

*Grid North—Grid Azimuth.*—At all points along the vertical line through the point selected as the origin of the system, the grid north and south line is coincident with the true north and south line that is the central meridian. The meridians on each side converge toward the center, which gives a difference between grid azimuth and true azimuth. This convergence is easily seen, when one considers that at the equator the difference between the 72nd and 73rd meridian is 1 deg., but at the pole it is 0 deg.; and the formula for

convergence is as follows: Convergence in seconds of angle equals difference in longitude of the two points (in seconds of angle) times the sine of the mean latitude of the two points.

In Fig. 62, consider the solid lines as being converging lines of longitude, marked as shown with the 73rd meridian as a central meridian of zone A. It is clearly seen that, at all points east of the central meridian, grid north is east of true north; and from all points west of the central meridian, grid north is west of true north. This means that, east of the central meridian, grid azimuth is less than true azimuth; and west of the central meridian, grid azimuth is

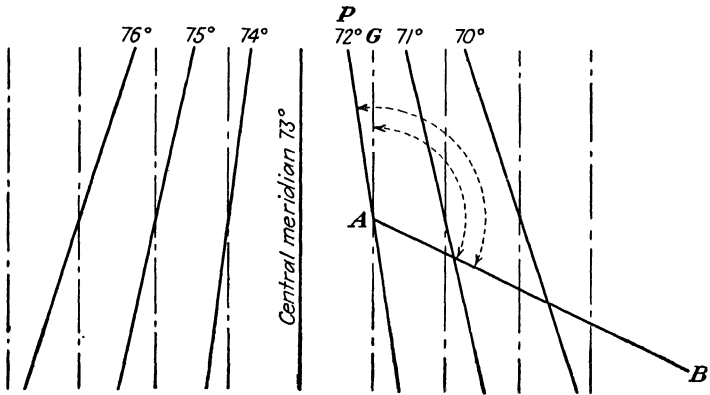

FIG. 62.—Grid declination shown by actual grid lines and true meridians. more. In Fig. 62, the difference of azimuths of  $AB$  is  $PAG$ . Grid azimuth is  $GAB$ , and true azimuth is  $PAB$ .

This difference in azimuth can be found in *Pamphlet 59*, Department of Commerce, page 33. This table is based on the theory that the tabular difference =  $\lambda \sin \phi - \frac{1}{2} \lambda^3 (\pi/180)^2 \sin 2\phi \cos \phi$ , where  $\phi$  = latitude and  $\lambda$  = longitude from central meridian.

In laying out the grid on a polyconic projection, remember that the origin of coordinates is on the central meridian of that zone. This meridian is coincident with the middle grid line. Lines that are mutually perpendicular are then laid out at 100,000-yd. intervals, north and south, and west and east.

*Illustrated Problem.*—Now let us take an actual case of computing and laying out a military grid. The problem involves not a complete zone, but only a part of a zone, and so the following procedure must be followed out:

For an example, we shall take a polyconic projection of a 2-ft. quadrangle at a scale of 1:4,800 (Fig. 63).

We first must determine the  $X$  and  $Y$  coordinates for each corner of our projection. A table of coordinates has been computed for the military

grid system (Grid System for Progressive Maps in the United States, *Special Publication 59*). The tables are computed for 5-minute intersections of latitude and longitude. To find the coordinates for intermediate intersections, it will therefore be necessary to interpolate.

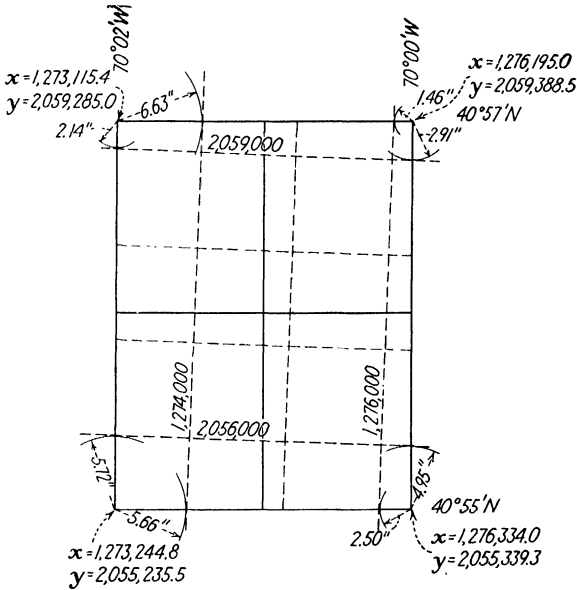

FIG. 63.—Layout of typical problem.

Starting with corner A—longitude 70°00' latitude 40°57'N., it will be necessary to interpolate between the coordinates for longitude 70°00' latitude 40°55', and longitude 70°00' latitude 41°00'. Setting up our problem:

$$\begin{array}{l}
 70^{\circ}00' \left\{ \begin{array}{l} X = 1,276,334.0 \text{ yd.} \\ Y = 2,055,339.3 \text{ yd.} \end{array} \right\} \begin{array}{l} A \\ \\ \\ \end{array} \\
 40^{\circ}55' \left\{ \begin{array}{l} X = 1,275,986.6 \text{ yd.} \\ Y = 2,065,462.3 \text{ yd.} \end{array} \right\} \begin{array}{l} 70^{\circ}00' \left\{ \begin{array}{l} X = 1,276,195.0 \text{ yd.} \\ Y = 2,059,388.5 \end{array} \right\} \\
 70^{\circ}00' \left\{ \begin{array}{l} X = 1,275,986.6 \text{ yd.} \\ Y = 2,065,462.3 \text{ yd.} \end{array} \right\} \\
 41^{\circ}00' \left\{ \begin{array}{l} X = 1,276,334.0 \text{ yd.} \\ Y = 2,055,339.3 \text{ yd.} \end{array} \right\}
 \end{array}
 \end{array}$$

Computation for X

Latitude 40°55'	1,276,334.0 yd.	Upper latitude is 40°57'	
Latitude 41°00'	1,275,986.6 yd.	Lower latitude is 40°55'	
	05'	347.4 yd.	02'
	$\frac{2}{5} \times 347.4 = 139.0$	Then for 40°57'	X = 1,276,334.0
		70°00'	- 139.0
			1,276,195.0

Computation for Y

Latitude 41°00'	2,065,462.3	$\frac{2}{5} \times 10,123.0 = 4,049.2$
Latitude 40°55'	2,055,339.3	
	05'	10,123.0



$$\begin{array}{r} \text{Then for } 40^{\circ}57' \ Y = 2,055,339.3 \\ \quad \quad \quad 70^{\circ}00' \quad \quad \quad \underline{4,049.2} \\ \quad \quad \quad \quad \quad \quad \quad 2,059,388.5 \end{array}$$

Similarly, we can set up the same pattern for the other three corners:

$$\begin{array}{l} B \\ \left. \begin{array}{l} 40^{\circ}55' \ X = 1,276,334.0 \\ 70^{\circ}00' \ Y = 2,055,339.3 \\ 40^{\circ}55' \ X = 1,268,661.0 \\ 70^{\circ}05' \ Y = 2,055,079.8 \\ 41^{\circ}00' \ X = 1,275,986.6 \\ 70^{\circ}00' \ Y = 2,065,462.3 \\ 41^{\circ}00' \ X = 1,268,323.2 \\ 70^{\circ}05' \ Y = 2,065,202.6 \end{array} \right\} \begin{array}{l} C \\ 40^{\circ}55' \ X = 1,273,244.8 \\ 70^{\circ}02' \ Y = 2,055,235.5 \\ 41^{\circ}00' \ X = 1,272,921.2 \\ 70^{\circ}02' \ Y = 2,065,359.2 \end{array} \left. \begin{array}{l} D \\ 40^{\circ}57' \ X = 1,273,115.4 \\ 70^{\circ}02' \ Y = 2,059,285.0 \end{array} \right\} \end{array}$$

We now have the coordinates for each corner of the projection; our next task is to locate even 1,000-yd. lines within the limits of our projection.

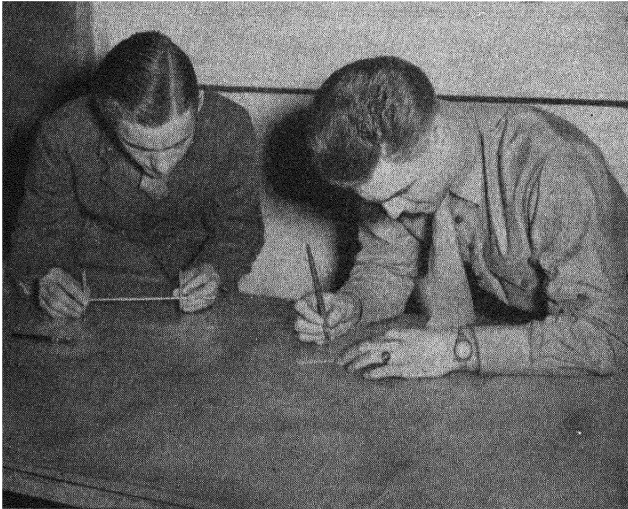

FIG. 64.—Construction of a polyconic projection and military grid system.

Let us locate an even 1,000-yd. *Y* line at the top of the projection. Both *Y* values are greater than 2,059,000. We know the *Y* values decrease to the south. That line is therefore to the south of the parallel.

$$\begin{array}{r} \text{In the northeast corner: } 2,059,388.5 \text{ yd.} \\ \quad \quad \quad \underline{-2,059,000.0 \text{ yd.}} \\ \quad \quad \quad \quad \quad \quad \quad 388.5 \text{ yd.} \end{array}$$

$$\text{Change to inches at projection scale: } \frac{388.5 \times 36}{4,800} = 2.91 \text{ in.}$$

Scribe an arc whose radius is 2.91 in. south of the parallel and meridian intersection.

$$\begin{array}{r} \text{Then for the northwest corner:} \quad 2,059,285.0 \text{ yd.} \\ \quad \quad \quad \underline{-2,059,000.0 \text{ yd.}} \\ \quad \quad \quad \quad \quad \quad 285.0 \text{ yd.} \\ \quad \quad \quad \quad \quad \quad \frac{285.0 \times 36}{4,800} = 2.14 \text{ in.} \end{array}$$

Scribe an arc whose radius is 2.14 in. south of the parallel and meridian intersection.

Procure a straightedge long enough to span the projection, place it tangent to the two arcs just scribed, and draw a line across the projection. This line is the even 2,059,000-yd. line.

Now at the southern limits we find the *Y* coordinates to be greater than 2,055,000; and so, to stay in the limits of our projection, we shall locate the even 2,056,000-yd. line, which is north of the lower parallel.

$$\begin{array}{r} \text{In the southeast corner:} \quad 2,056,000.0 \text{ yd.} \\ \quad \quad \quad \underline{-2,055,339.3 \text{ yd.}} \\ \quad \quad \quad \quad \quad \quad 660.7 \text{ yd.} \\ \quad \quad \quad \quad \quad \quad \frac{660.7 \times 36}{4,800} = 4.95 \text{ in.} \end{array}$$

This is the radius of the arc scribed north of the southeast corner.

$$\begin{array}{r} \text{In the southwest corner:} \quad 2,056,000.0 \text{ yd.} \\ \quad \quad \quad \underline{-2,055,235.5 \text{ yd.}} \\ \quad \quad \quad \quad \quad \quad 764.5 \text{ yd.} \\ \quad \quad \quad \quad \quad \quad \frac{764.5 \times 36}{4,800} = 5.72 \text{ in.} \end{array}$$

This is the radius of the arc scribed north of the southwest corner.

Then draw a line tangent to the two arcs, and the even 2,056,000-yd. line is plotted.

The *X* coordinate lines are located in the same manner; recalling our *X* values increase to the east, we proceed. Our *X* coordinate in the southeast corner:

$$\begin{array}{r} 1,276,334.0 \text{ yd.} \\ \underline{-1,276,000.0 \text{ yd.}} \\ \quad \quad \quad 334.0 \text{ yd.} \\ \quad \quad \quad \frac{334.0 \times 36}{4,800} = 2.50 \text{ in.} \end{array}$$

northeast corner:

$$\begin{array}{r} 1,276,195.0 \text{ yd.} \\ \underline{-1,276,000.0 \text{ yd.}} \\ \quad \quad \quad 195.0 \text{ yd.} \\ \quad \quad \quad \frac{195.0 \times 36}{4,800} = 1.46 \text{ in.} \end{array}$$

Scribe arcs to the west of their respective corners, and draw a line tangent to the two arcs, which will be the 1,276,000-yd. line.

Observing the western edge of the projection, we see both *X* values are just over 1,273,000, and so our 1,274,000-yd. line would be just to the east of our projection line.

$$\begin{array}{r} \text{southwest corner:} \quad 1,274,000.0 \text{ yd.} \\ \quad \quad \quad \underline{-1,273,244.8 \text{ yd.}} \\ \quad \quad \quad \quad \quad \quad 755.2 \text{ yd.} \\ \quad \quad \quad \quad \quad \quad \frac{755.2 \times 36}{4,800} = 5.66 \text{ in.} \end{array}$$

$$\begin{array}{r} \text{northwest corner:} \quad 1,274,000.0 \text{ yd.} \\ \quad \quad \quad \underline{-1,273,115.4 \text{ yd.}} \\ \quad \quad \quad \quad \quad \quad 884.6 \text{ yd.} \\ \quad \quad \quad \quad \quad \quad \frac{884.6 \times 36}{4,800} = 6.63 \text{ in.} \end{array}$$

## 82 AERIAL SURVEYING AND PHOTO INTERPRETATION

Scribe arcs east of the northwest and southwest corners, and draw a line tangent to the two arcs, which will be the 1,274,000-yd. line.

We now have a rectangle 2,000 by 3,000 yd. We can further subdivide this into 1,000-yd. squares. Each square would be

$$\frac{1,000 \times 36}{4,800} = 7.5 \text{ in.}$$

on the side.

If by chance the divisions do not come out exactly, it is wise to check back over the projection and grid computations before proceeding with the plotting of points.

CHAPTER VI  
TOPOGRAPHIC DRAFTING  
DRAWING INSTRUMENTS

It is customary for a student of map making and interpretation to study drawing (1) to gain an understanding of the principles on which drawing is based and (2) to gain practice in the use of instruments.

It is assumed that the student who desires to undertake a topographical drawing course is already familiar with the use of the ordinary drawing instruments. This experience may be gained by taking a good course in mechanical drawing or by constant practice.

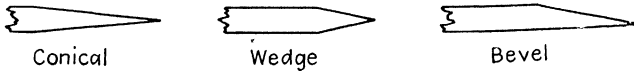

FIG. 65.

However, there are a few points concerning these instruments and equipment that may be worthy of noting.

**Pencils** come in varied degrees of hardness ranging from 6B (soft and black) to 9H (hard). The hardness to be used depends on the job to be done. However, the important item is the condition the pencil is kept in. It is good practice to keep the tapered wood portion about  $\frac{7}{8}$  in. long, with about  $\frac{3}{8}$  in. of lead exposed, using a file or sandpaper to maintain an edge.

There are three different points that may be sharpened on the pencil, depending on the use to be made of it (see Fig. 65).

When in use, a pencil should always be held slightly inclined to the direction of motion:

**Pens.**—All new pens are unfit for immediate use, because of a slight film of oil that covers them. This oil can be removed by alcohol or by burning. Ink should not be allowed to dry on the pens. They should be wiped dry every few minutes. When loading with ink, the quill provided in the ink bottle should be used. All pens if used properly will give a good line except on tracing paper or acetate, which has a slight oily surface. However, if the hands are not touched to the paper, a slight sprinkling of talc or chalk dust will allow the pen to make a very good line.

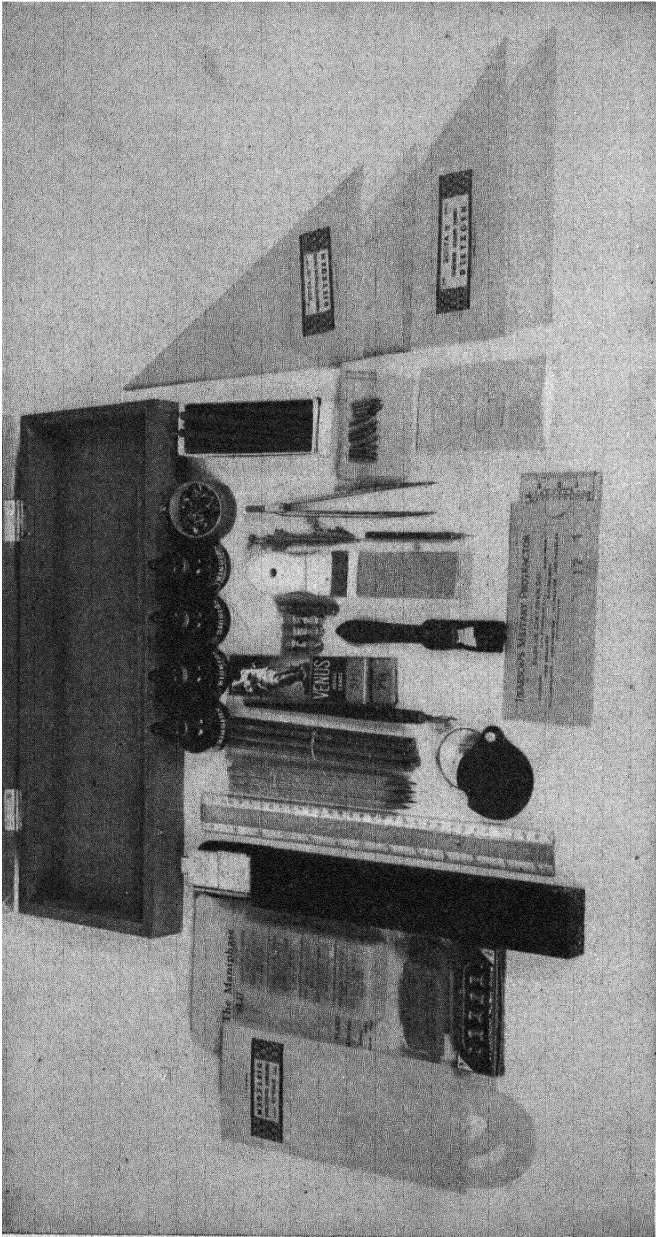

FIG. 66.—Complete drafting kit furnished the U.S. Marine Corps by Abrams Instrument Co. to be used in conjunction with the contour finder and plane table. For contents of kit see opposite page.

**Ruling pens** should be held in the same way as the pencil, slightly inclined in the direction of motion in a plane perpendicular to the paper plane. Long lines are to be inked with an arm movement ending with a finger movement.

These pens have parabolic-shaped nibs that should contain not more than  $\frac{1}{4}$  in. of ink.

If the ink does not flow freely from the nibs, draw the pen across the forefinger. This process starts the flow of ink again.

**Bow Pens.**—The same rule for filling with ink applies to a bow pen. This pen is used to ink circles, etc. In changing the nibs, to vary the weight of the line, pinch the nibs together to relieve the pressure on the nut and screw.

**Railroad Pens.**—A special double pen for inking parallel lines. It has so many disadvantages that its use is not recommended.

**Crow-quill pens** are used for fine printing and topographic sketching.

**Contour Pen.**—This is a special tool, used in drawing contours on large-scale maps. This pen has blades so curved as to place the point off the axis of the pen handle.

**Beam Compass.**—An instrument for drawing circles of larger radius than can be drawn with an ordinary compass.

**Drawing Board.**—Soft pine or basswood with no cracks—should have one straight edge and is not to be used for cutting purposes. It should be placed, when in use, so that the light strikes the board from the front and left.

**T Square.**—A T square can be made with or without an adjustable head, of wood, steel, or celluloid. The only specification is that the upper and inner edge should be straight and true.

**Triangles.**—30, 45, and 60 deg., made of wood, steel, or celluloid. Some of the smaller ones are subdivided to be used as a lettering triangle.

**Pantograph.**—This is an instrument consisting of a frame containing an adjustable parallelogram and so designed that, when any

1 Maniphase slide rule	12 crow-quill penholders and points
1 slide-rule instruction book	1 magnifier
1 beveled scale	1 steel eraser
1 celluloid curve	1 drop-bow pen
1 30-60 deg. triangle	1 dividers
1 45 deg. triangle	1 stylus
1 Pearson's military protractor	1 pencil pointer
4 bottles India ink	3 trammel bar heads
4 Artgum erasers	2 boxes refill leads 5H to 7H
4 red rubber erasers	1 pair of contour-finder floating dots
6 5H pencils	Thumbtacks
6 3H pencils	Push pins
1 penholder and points	1 wooden carrying case

figure is passed over by its tracing point, the copying point will describe an exactly similar figure on a smaller or larger scale.

**Protractor.**—A graduated circle or semicircle, with an accurately marked center. It may be printed in paper, or made of celluloid or steel.

**Scales.**—The ordinary engineer's scale is universally used. With it, scales in any multiple of 10, 20, 30, 40, 50, and 60 ft. to the inch may be used.

Other auxiliary instruments may be railroad curves, section liners, straightedge paper weights, and proportional dividers.

**Inks.**—Black, brown, green, blue, red, and yellow may be required. The ordinary waterproof drawing inks may be used and are generally best.

#### *Rules for Inking:*

1. Do not make lines too fine—they may become ragged.
2. Hold pen nearly vertical—both nibs on the paper.
3. Do not ink too close to the edge of T square or triangle.
4. Never ink backward.
5. Ink all circles and arcs first. It is easier to make a straight line tangent to a circle than to make a circle tangent to a line.
6. When inking in a drawing it is customary to ink from top to bottom and left to right.
7. When several lines meet at a point, ink from point out, allowing line to dry first.
8. Dirty ink should be discarded.
9. Keep pens sharp, clean, and in good shape.

### TOPOGRAPHIC SYMBOLS

**Why Symbols Are Used.**—Only a limited amount of detail can be shown per square inch, on a topographic map, if all features are shown to the same scale. For this reason symbols are used to represent the different features such as relief culture and vegetation.

A topographic map corresponds to the plan view in orthographic projection. Symbols should resemble the plan view of the object they represent.

**Kinds of Symbol.** *Civil Works or Structures.*—Included under the category of civil works or structures are all buildings, bridges, roads, railroads, canals, docks, bridges, oil and gas wells, mines and quarries, telegraph lines, and cemeteries. They are all made with black ink and, although not exactly like the original, are standardized.

*Natural Features.*—Symbols include those for vegetation, woods, cleared land, water and streams, crops, erosion, sand dunes, and

marshland. These are usually made in plan, but often the symbols for certain crops are shown in elevation, giving a very pleasing appearance.

*Miscellaneous.*—Many branches of engineering, such as navigation, military, oil and gas engineering, and geology, have adopted symbols

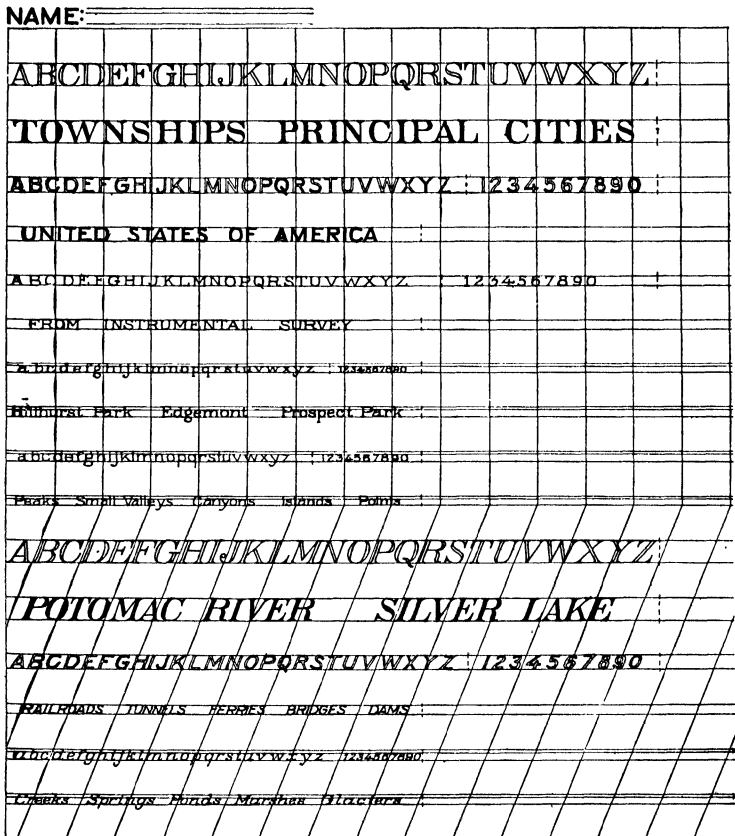

FIG. 67.—Map lettering.

of both types; and, although these are not in common use, they are used on maps concerning these industries. They are simple in their execution and need no special instruction.

**Shading of Symbols.**—Shading of symbols to give the effect of light is often used to accentuate the features of a map. In drawing, the source of light is considered to be above and to the left of the object. Objects above the horizon are shaded on the side farthest



from the light, and objects below the horizon are shaded on the side nearest the light.

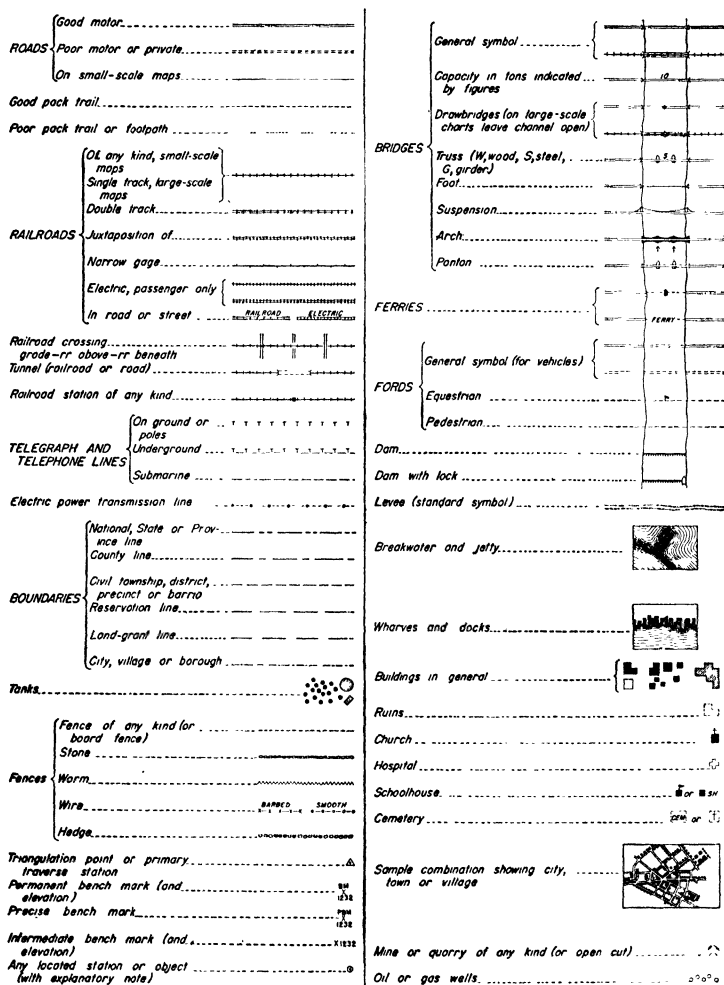

FIG. 68.—Topographic symbols for civil works or structures.

**Composition.**—The combining of the various symbols into a neat and readable map requires experience and good taste. Clearness should be combined with good draftsmanship. A good rule to follow is to ink the most important things first and then follow with the others in order of their importance, toning down the weight of the

lines in proportion. The least important things, such as cleared land and grass, should be used to even up the tone of the map.

**Symbol Sheets.**—The size and purpose of this book prohibit the discussion of all types of symbols; complete symbol sheets can be

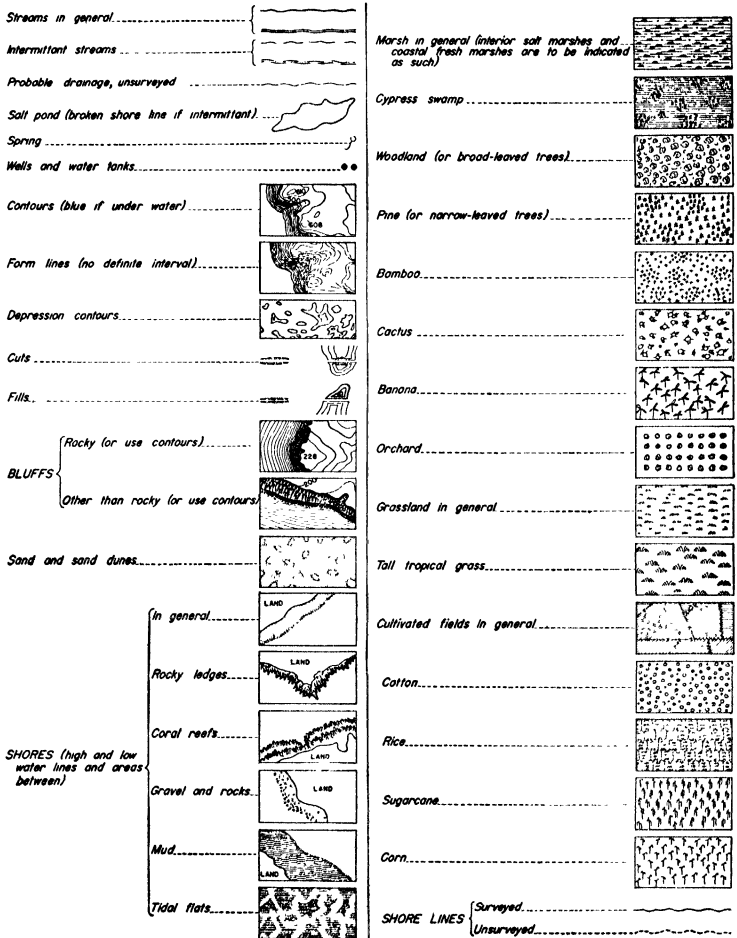

FIG. 69.—Topographic symbols for natural features.

obtained from governmental sources. A great effort has been made by the Division of Cartography, Soil Conservation Service, to collect all efforts at symbol making and set up some kind of standardization. They now furnish a complete set of topographic and

Military post or station, command post or headquarters		Battalion, cavalry squadron, or Air Corps.....	II
Troop unit.....		Regiment or Air Corps group.....	III
General hospital.....		Brigade or Air Corps wing.....	X
Mobilization point or area (capacity in figures)		Division.....	XX
Observation post.....		Corps.....	XXX
Reception center.....		Corps area, department, or section of communications zone	OOO
Supply depot.....		Communications zone.....	OOOO
General or base depot.....		Army.....	XXXX
Supply train or transportation unit.....		General headquarters.....	GHQ
Air Corps.....		GHQ Air Force.....	
Artillery.....		Squad.....	—■—
Cavalry.....	/	Section.....	—■—
Chemical Warfare Service.....	G	Platoon.....	—■—
Coast artillery, antiaircraft.....		Company or similar unit.....	—■—
Engineers.....	E	Battalion or similar unit.....	—■—
Infantry (except tanks and military police).....	X	Regiment or similar unit.....	—■—
Tanks.....		Brigade.....	—■—
Medical Department.....	+	Division.....	—■—
Ordnance Department.....		Corps.....	—■—
Quartermaster Corps.....	Q	Corps area, department, or section of communications zone	—OOO—
Signal Corps.....	S	Army.....	—XXXX—
Squad.....		Rear boundary of theater of operations	GHQ
Section.....	..	Front line.....	
Platoon.....	...	Outpost line.....	OPL
Company, troop, battery or Air Corps flight.....	I	Main line of resistance.....	MLR
Support line.....	SL	Headquarters and Headquarters Squadron, GHQ Air Force	
Line of communication.....	—L of C—	Light Machine-gun Platoon, Troop A, 2d Cavalry	
Line of departure.....	LD	Machine-gun Troop, 7th Cavalry.....	
Airdrome.....		1st Squadron, 4th Cavalry.....	
Antitank gun.....		Command Post, 5th Cavalry Brigade.....	
Area, gassed, to be avoided.....		Company C, 901st Chemical Regiment.....	c
Automatic rifle.....		Battery A, 104th Coast Artillery (AA).....	A
Dugout (isolated).....		Company A, 2d Engineers (combat).....	A
Dugouts (in connection with trench).....		301st Engineers (general service).....	
Entanglement (concealed).....		Battery F, 2d Field Artillery.....	F
Entanglement (wire).....		951st Field Artillery Battalion (mechanized).....	
Landing field.....		Headquarters Company, 3d Infantry.....	

FIG. 70.—Military topographic symbols.

architectural symbols on 8½- by 11-in. sheets, which are available at a nominal charge.

**Specifications.**—As with everything else done under the guise of engineering work, topographic-symbol drawing requires specifications. A few of these for the more common natural features will now be listed.

*Water Lines.*—When well made, water lines add much to the drawing. When poorly made, however, they are offensive to the observer.

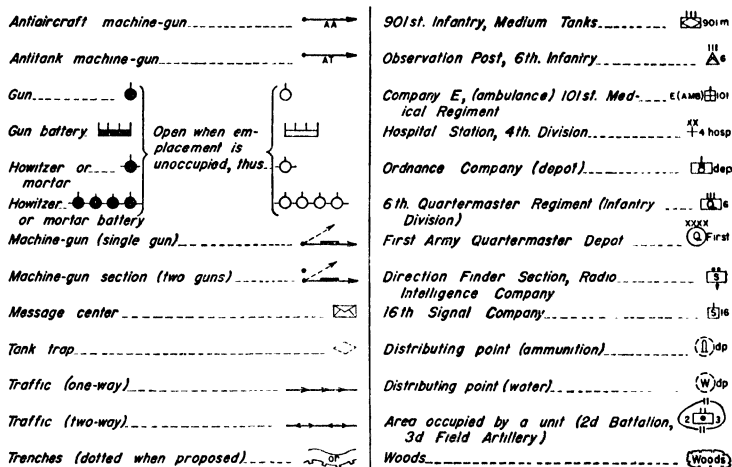

FIG. 71.—Special military topographic symbols.

They should not be made too fast, for every bend and irregularity in the shore line must be followed.

*Shore Lines.*—The shore line is made heavy—and the first water line as close as possible to it. The spaces between water lines gradually widen, each space having 1½ times the width of the previous space. This work is done freehand with a crow-quill pen. Use a contour pen and make the lines quite heavy. When no water lines are to be added, use black ink; when water lines are to be added, the shore line should be blue.

*Trees.*—Use a crow-quill pen. The full-sized symbol should have 8 to 10 scallops, the size depending on the scale of the map. Symbol should be as nearly circular as possible. Shading is accomplished by varying the size of line, the northwest side being lighter than the southeast.

*Shade Trees.*—These trees have probably been planted, and hence it is customary to add shade lines. The easiest way to do this is to add horizontal lines, starting with a very short one at the center of

the symbol. Then follow with about four other lines, increasing the length until the last line drawn from the bottom of the tree is about half the diameter of the symbol. These lines are drawn horizontal and extend from the symbol to the right.

*Cultivated Fields.*—Cultivated fields are usually indicated with lines and dots parallel to one boundary of a tract. Black ink is used. Lines should be drawn with a ruling pen and the dots with a writing pen. If different ownership is to be shown, the lines of each field should have different directions.

*Sand.*—Making the symbol for sand is very tedious and requires patience and good eyesight. A series of dots the same thickness as the shore line and as close together as possible are placed along a shore line. Back of this line of dots, place another row with a finer pen but just as close together. From this point and for a distance of  $\frac{1}{2}$  in., the dots are scattered thickly over the surface. Remember these dots are not dashes.

*Clearing.*—A clearing is composed of a mixture of trees and grass with an occasional symbol for a stump. Draw a stump with a narrow ellipse; then, extending down from either end of the ellipse, draw two short lines, each one slightly curving, one to the left, one to the right. Do not make the stump too high.

*Marsh.*—First ink the outline of the marsh with a medium black line. Inside this border, line the area with short horizontal lines in blue, and on these blue lines place the grass symbol in black.

## CONTOURS

Many studies of natural resources and designs of engineering projects require a representation of the character and relief of the earth's surface. This is done with hachures, shading, relief maps, relief models, and, most commonly, contours.

**Plastic and sometimes wood models** showing the shape of the ground surface convey the picture of relief more clearly than any other method to the layman as well as to the engineer. Size, bulk, and difficulties in shaping limit their use for accurate expression of relief to large-scale models of small areas. Rough relief to a small scale is often shown by this method for extensive areas.

**Shading.**—Many schemes of shading hills and valleys to show ground relief are possible, but hachures and form lines are the most common. Next to relief models, shading methods present the clearest picture to the layman. All forms of shading require time and ability; therefore their use is limited entirely to showing abrupt features of relief such as rock cliffs, eroded banks, cuts, and fills. Here in the United States the use of hachures is quite limited.

They are used in military maps to some extent, but the Army is trying to do away with them. The method has been very common in Europe. They are more accurate but less easily visualized than other forms of shading.

**Form lines** may be used when the general shape of relief is desired and accuracy is not required. Navigation maps often show line relief by hachures or form lines. To the navigator the important features of relief are the location of peaks and the general outline of the ground surface.

**Contour Lines.**—The most common method of showing configuration is by contour lines, imaginary lines connecting points of equal elevation. Although perhaps not easy for a layman to interpret, they permit the portrayal of the ground surface with precision and ease and are the only practical method of showing relief of flat or gently sloping country. They are also easier to handle in drafting and interfere less with other topographic symbols.

The vertical component of the slope between any two adjacent contours is a constant value and is called the *contour interval*. Intervals vary as follows: for small-scale maps of rough country 20, 25, 50, 100 ft., or more; for large-scale maps of gently sloping ground  $\frac{1}{2}$  to 1 ft. A general average for contour intervals is 2, 5, or 10 ft.

There are three distinct operations necessary to construct a contour map.

1. Plotting of control points from which topographic data were taken in the field.

2. Plotting details from the control points.

3. Interpreting and drawing in contour lines.

A contour line can be drawn on a map if the plotted position and elevation of properly selected ground points are given. These points serve as guides in determining the location of contours. These points may be arranged or grouped in different ways, depending on the conditions of the country.

*Gently Sloping and Rolling Country.*—We can locate a sufficient number of points on lines of equal elevation after these points have been plotted on the map; and by connecting the lines we can fix the contour directly without interpolation.

*Rough Country.*—When only narrow strips are involved various systems that involve interpolation can be used.

1. Establish a grid system by laying out the ground in measured squares or rectangles of a known size. Markers must be put at all corners, and elevations must be taken at all points.

NOTE: This system can be used at any time for any type of country but is preferred for rough country.

2. The system that is used in gently sloping and rolling country can also be applied to rough country. When a series of points having the same elevation are located on the ground and plotted on a map, the line joining these points will be a contour. This system requires a long time in the field and the location of many points.

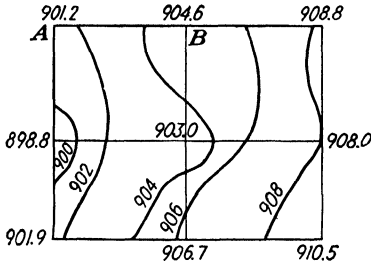

FIG. 72.—A grid system for contouring. System 1.

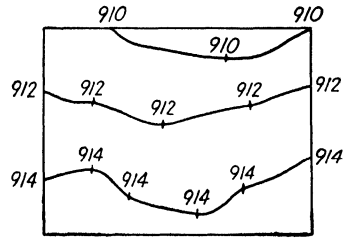

FIG. 73.—System 2 for gently sloping or rolling country.

3. Another system involves the location of only a few control points, summits, depressions, ridge points, and valley lines. Interpolation is then used.

4. In a method used by highway and other right-of-way surveyors, a traverse is run and staked every 100 ft., over which profile levels

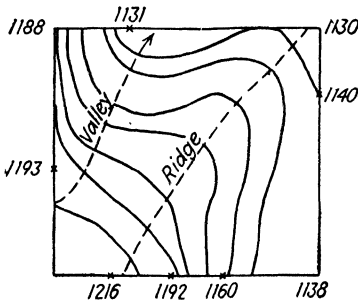

FIG. 74.—System 3, requiring interpolation.

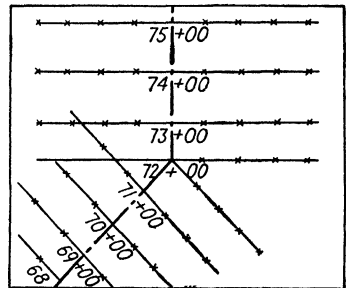

FIG. 75.—Cross-sectional method (system 4), as used by highway engineers.

are taken. At these points, X sections are taken to locate contours. These cross sections are taken at right angles to the center line and at intervals of about 25 ft. or at every abrupt break in ground.

**Construction of Contours.**—There are four methods of constructing contour lines: (1) estimation, (2) calculation, (3) graphical, (4) rubber band.

*Estimation.*—Estimation is used when the highest accuracy is not needed, and where ground forms are quite regular (see Fig. 74).

*Calculation.*—When high accuracy is required, calculations like the following are used (see Fig. 72):

*Example.* Between points *A* and *B*, the difference in elevation is 3.4 ft. The difference in elevation between *A* and the next contour is 0.8. The distance from *A* to the next contour is  $0.8/3.4 \times \text{length of } AB$ . If *AB* is 100 ft., the point where the 902-ft. contour crosses the grid line is 24 ft. from *A*. To the 904-ft. contour,  $904 - 901.2 = 2.8$  ft.

$$\frac{2.8}{3.4} \times 100 = 82 \text{ ft. from } A \text{ to } 904\text{-ft. contour.}$$

*Graphical Method.*—If many interpolations are to be made and a high degree of precision is required, it is more rapid and convenient to provide a scale for interpolating (see Fig. 76).

Obtain the difference in elevation between two points. Here *A* and *B* are 9.8 ft. apart. Take any piece of cardboard or paper and lay off on it, to any scale, about 10 spaces. Then place the zero point on this scale on point *A*. Then draw a line from the point 9.8 to point *B*. Connect *A* and *B* with a straight line. Then, if contours are required every 2 ft., estimate on the scale where the 908-ft. contour would

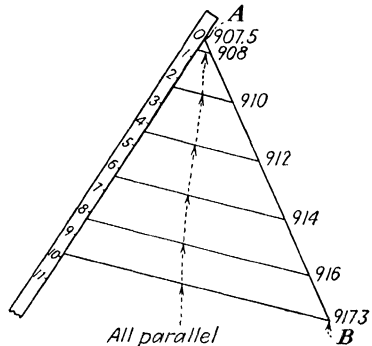

FIG. 76.—Graphical interpolation scale.

originate on the scale. Then, from this point on the scale, draw a line parallel to the bottom line through *B*. Proceed in the same way for every other interval.

*Rubber-band Method.*—This is a rather crude method but can be used for hasty interpolation.

1. Acquire a rubber band  $\frac{1}{8}$  to  $\frac{3}{4}$  in. wide.
2. Pin one end with a thumbtack to a board.
3. Stretch band to about  $1\frac{1}{2}$  times its normal length.
4. Take a ruling pen and ink and make lines at regular scaled intervals along the length of the stretched rubber. This is now similar to the cardboard template used in the graphical method.
5. Now insert the thumb and forefinger inside the rubber band and stretch the band far enough so the two extreme inked lines are directly over the two points between which we are to interpolate.



Then the intermediate inked lines represent intervals for contour lines.

**Generalization.**—It is best to plot only a few points on any contour line and then sketch in freehand the line itself. The lines are fairly regularly curved, except for rough country, etc. Therefore, they are rather smooth curves that conform to one another, more or less closely, depending on the regularity of the ground forms. Drawing them requires good judgment and skill. Every fifth contour line is usually sketched a little heavier than the others.

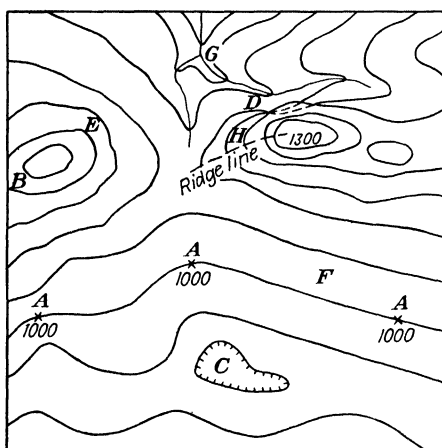

FIG. 77.—The chief characteristics of contours.

**Hachures from Contours.**—Contour lines are first drawn in very lightly in pencil. The hachure symbol is a line following the slope between contours. It is drawn from one pencil line to another, so that, when the pencil contour line is erased, each row of hachures is separated from the next by a narrow strip of white. The spacing is governed by this rule:

*The steeper the slope, the heavier the symbol and the smaller the space between symbols.*

**Characteristics of Contours.**—The chief characteristics of contours are illustrated in Fig. 77 and may be summed up as follows:

1. All points on any one contour have the same elevation, as at A.
2. Every contour closes on itself, either within or beyond the limits of the map. If the contour does not close within the limits of the map, it will run to the edge of the map, as at B.
3. A contour that closes within the limits of the map indicates either a summit or a depression. In depressions there will usually

be found a pond or a lake; but where there is no water the contours are usually marked in some way to indicate a depression, as at *C*.

4. Contours can never cross each other except where there is an overhanging cliff, and here there must be two intersections, as at *D*. Such cases seldom occur.

5. On a uniform slope contours are spaced equally, as at *E*.

6. On a plane surface they are straight and parallel to each other, as at *F*.

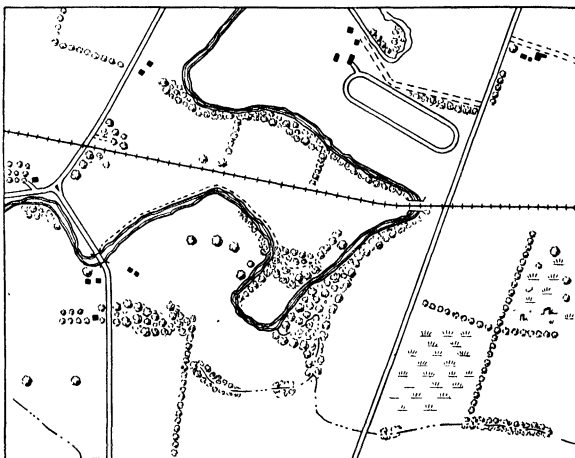

FIG. 78.—A hasty overlay of Fig. 79.

7. In crossing a valley, the contours run up the valley on one side and, turning at the stream, run back on the other side, as at *G*. Since the contours are always at right angles to the lines of steepest slope, they are at right angles to the thread of the stream at the point of crossing.

8. Contours cross the ridge lines (watersheds) at right angles, as at *H*.

9. In general, the curve of the contour in a valley is convex toward the stream.

10. All contours are multiples of their intervals, and every fifth one is usually made heavier.

### HASTY MAPS AND OVERLAYS

It is often desirable and frequently necessary to make a line map from a photograph. In this manner, unnecessary detail can be eliminated and the really important items can be emphasized through the conventional symbols adapted for that purpose. This line map is called an overlay or hasty map and is usually made on a

transparent substance like vellum or acetate. It is made by laying the transparent surface directly on top of the photographs and tracing the detail shown in the photograph onto the overlaying material.

**Method of Preparing—Registering the Photograph.**—Select a light, tough vellum. Cut it to a size slightly larger than the print, or one side can be folded over onto the back of the print and held there by scotch tape. The paper being somewhat larger than the print, lines should be drawn on the paper indicating the edges of the print, collimation marks, print number, and flight number. This is what is known as registering the photograph.

**Tracing of Detail.**—The question to be answered at this time is what features should be traced from the print? The answer to this question can be found in the purpose of the overlay. For certain types of work, some features are more important than others; therefore, they would be the first ones to be traced, and all others would be secondary. However, for all purposes, including military, there are certain topographical features that are always important. They are communication and transportation lines, hydrographic details, public buildings, and coverage.

These items are traced through onto the vellum, using the required symbol and maintaining the scale of the print as closely as possible.

After the important items are traced, the secondary information, such as kinds of crops, cultivated fields, orchards, trails, and private buildings, should be traced to make a complete tracing.

**Compiling.**—An overlay could be made for several adjoining photographs in a flight. Then, because there is an overlap of prints in the direction of flight, there will be an overlap of adjacent overlays also. The overlays could then be fitted together to form a hasty line map of a much larger area and could be of utmost importance for reconnaissance work.

## CHAPTER VII

### HOW AERIAL PHOTOGRAPHS ARE MADE

#### AERIAL EQUIPMENT

In the following chapters of this text we shall consider the taking and processing of an aerial photograph and make an attempt to show how the material that is furnished a map maker is prepared. A map maker must know the errors existing in an aerial photograph, the reasons for and methods of eliminating them; or he might otherwise be working under the most adverse conditions in trying to construct a good map.

**The Photographic Airplane.** *Requirements.*—Almost any two-seated airplane can be used for photographic purposes if the specifications required are not too rigid. Some types of airplane are of course better suited for making certain kinds of survey. An opening in the floor of the cockpit is a necessity for making vertical aerial photographs and should be located to give convenient access to the camera. The interior of the airplane should have ample room for the camera equipment, the operator, and pilot. The vertical view finder also requires a small opening near the mechanism of the camera. One of the main requirements of a good photographic ship is that it have a clear view ahead for the pilot. Usually most mapping projects involve long flights at considerable altitude, and the airplane should be equipped with a large fuel capacity and oxygen equipment. Most flights in the past have been between 10,000 and 20,000 ft., but in war areas a much greater altitude is often necessary. Then we must have an airplane equipped to fly at great heights and speed. For commercial purposes, economy of course is a factor, and most concerns use slower airplanes with lower ceilings to cut down cost. They secure the scale desired by changing the focal length of the camera.

*Types of Airplane Used.*—One of first airplanes designed for photographic operation was the Fairchild 71. This airplane has probably given more service to the cause of aerial photography than has any other type of commercial plane. It has been in use for the past decade.

In 1937, the Explorer airplane was designed and built by the Abrams Aircraft Corporation for the purpose of reducing the cost of

taking aerial photographs. This was accomplished by installing the motor behind the wings, to give the airplane better performance and visibility, so that the pilot could maintain his proper direction and position in relation to the flight line.

Some other airplanes, standard models with minimum changes, have turned in good records year after year in commercial mapping. Cessna Airmasters, Beechcraft, and Lockheed Vegas are still operating successfully at 20,000 ft. on regular assignments. Some other

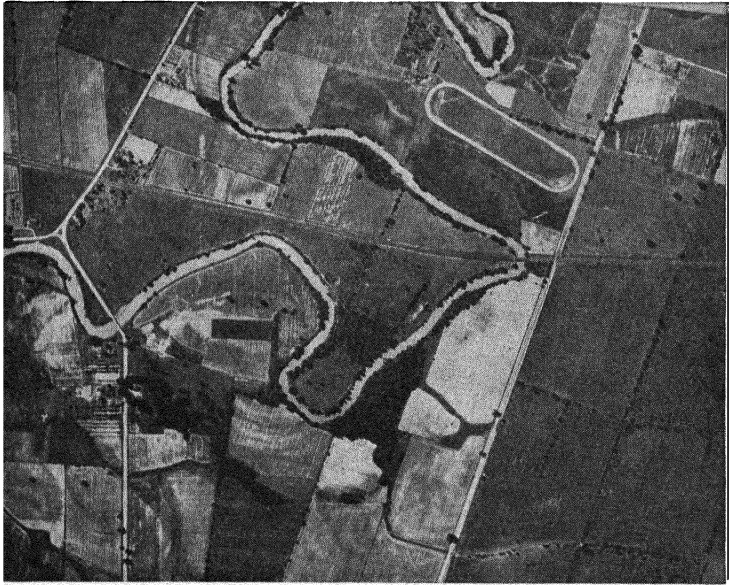

FIG. 79.—Photograph from which Fig. 78 was made.

well-known predecessors of today's commercial mapping ships were the Bellanca, Ryan, Curtiss Robin, Stinson, and Waco. Modern military photographic airplanes are generally designed with specific purposes in mind. In some instances, four-motor bombers and observation ships are used. These airplanes, in addition to carrying the regular crews, equipment, and loads, also carry camera equipment for the purpose of taking photographs of all types. Generally speaking, any airplane is suitable for photographing if it is capable of carrying the required equipment and crew, can climb the desired height, has necessary range requirements, and has visibility for pilot and camera operation.

**Cameras and Accessories.** *Types of Aerial Cameras.*—The *single-lens camera* is used for taking pictures one at a time and can be

either vertical or oblique. It consists of a body, a cone, and a magazine. The cone is detachable and interchangeable with various lengths providing for lenses of various different focal length, ranging from 3 to 50 in. The most common focal lengths are 6,  $8\frac{1}{4}$ , 10, 12, and 20 in. All the older makes of aerial cameras were of the single-lens type, some having cut film and glass-plate magazines. Today almost all the cameras made in the United States are made for loading with roll film, with magazine capacities of 100 to 600 exposures. The size of picture that single-lens cameras take varies from 4 by 5 in. to 9 by 9 in. Government cartographers have requested that all cameras be made to size 9 by 9 in. This size of photograph covers larger areas on each exposure and also gives longer base measurements between exposures, so that relief is more prominent when looking at an overlapping pair stereoscopically. In other words, the accuracy of stereoplotting is increased.

Some of the most recently made cameras producing 9- by 9-in. photographs are (1) the Fairchild photogrammetric aerial camera, (2) the Mark Hurd photogrammetric aerial camera, (3) the Aero Service Corporation photogrammetric aerial camera, (4) the Park photogrammetric aerial camera, and (5) the Abrams Explorer precise mapping camera, all of which have been built according to rules and regulations specified by the government. The regulations required in making a precise aerial mapping camera are:

1. Between-the-lens shutter.
2. Vacuum-plate back.
3. 9- by 9-in. focal plane.
4. Detachable lens cone.
5. Body frame between lens and focal plane made of a metal that has a low coefficient of expansion.
6. Fiducial marks constructed permanently in the focal plane in the exact center of each side.
7. Lens tested by Government Bureau of Standards.

All these factors are considered in the construction of the Abrams Explorer precise mapping camera (model C-3), and several new features have been added. In design and appearance it is different from others, having a round and smooth exterior surface. It is constructed with a cast-aluminum framework that supports a separate focal plane and lens frame made of invar steel, which has a very low coefficient of expansion. That being so, the change of temperature at various heights does not change the focal length of the camera.

The film magazine and winding mechanism are all one unit but are built large enough to contain 650 exposures, or a full day's run

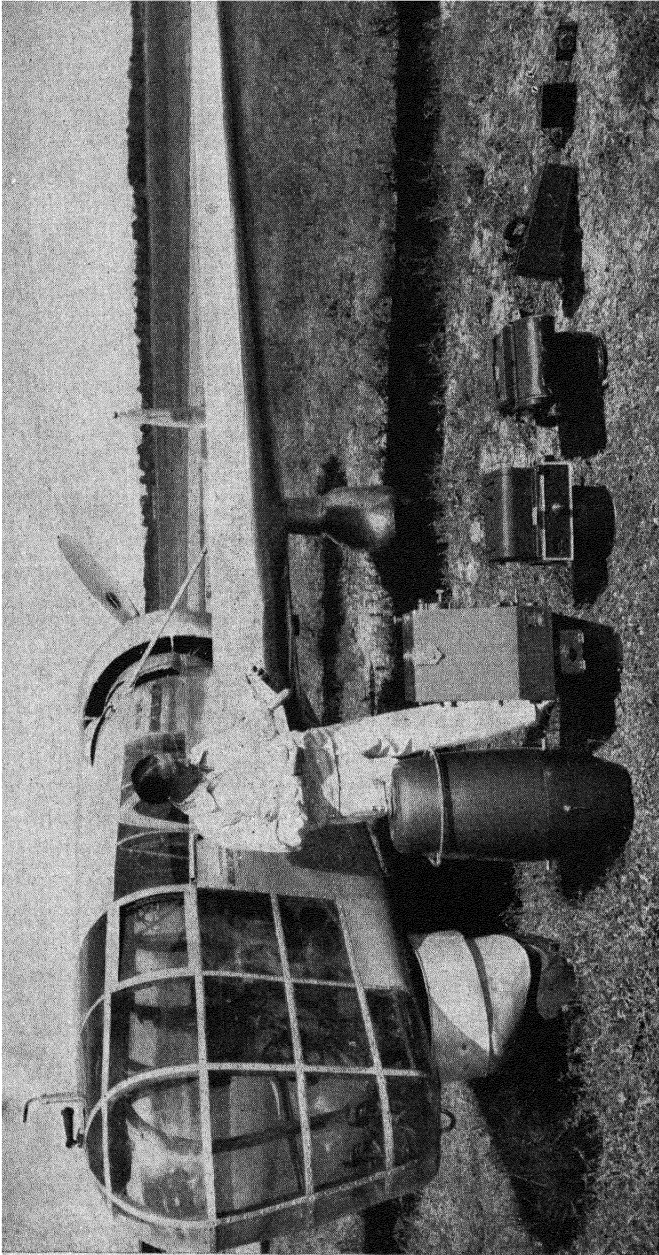

**FIG. 80.**—Modern photographic airplane. The Abrams Explorer, manufactured by the Abrams Aircraft Corporation.

of film. Therefore, the unit can always be loaded or unloaded in a darkroom. A film punch is mounted on the side to mark the places on the film where it can be cut, indicating separate jobs flown or the end of a day's run. The operating parts are all mounted on top of the camera, very conveniently for the operator. They consist of a stop watch, a film-winding crank, a shutter trip in the center of the handle, a level bubble in the center of the shutter trip, and an exposure counter. All the gears are constructed of steel and fiber to decrease the meshing noise and to make for easy operation.

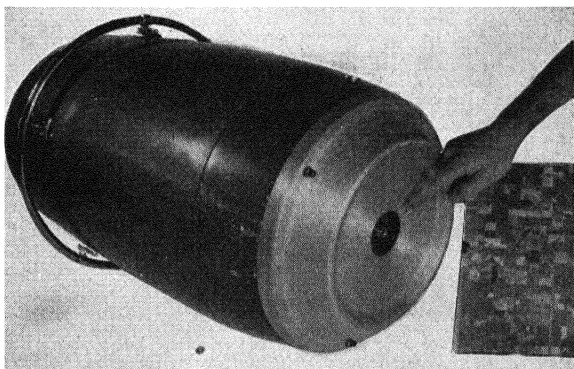

FIG. 81.— Abrams C-3 model precision camera, showing coverage made on a 9- by 9-in. photograph with a  $4\frac{1}{4}$ -in.-focal-length lens.

The camera has a series of cones ranging from a  $4\frac{1}{4}$ -in. focal length to a 12-in. focal length. It takes a negative 9 by 9 in. The shutters are the between-the-lens type. The film is held flat during exposure by a vacuum back. The camera is easily held vertical and oriented by a ring encircling the magazine casing. The axis stubs used for mounting the camera in the mount have been located near the center of gravity. A door is mounted on the side below the focal plane to aid in loading of the film or for inspection purposes.

*Multiple-lens Camera.*—Multiple-lens cameras are devised especially for making composite photographs for covering large areas in a single exposure. They have been built containing three, five, and nine lenses, and all are of equal focal lengths in each camera. One is mounted in a vertical position, and the others are hung on the same frame but set at an angle to the vertical producing obliques. These obliques are transformed by reprojection to the same scale as the vertical, so that all can be matched to produce a single photograph. The latest type of multiple-lens camera has three units, two of which are mounted at 60 deg. to the vertical, each producing



a 9- by 9-in. photograph. The horizon shows on the two wing prints (Fig. 82). It is called the *trimetrogon system*.

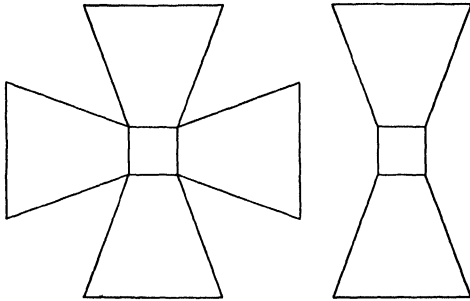

FIG. 82.—Pattern covered by a 3- and 5-lens camera.

Figure 83 shows a diagram made of the assembly of individual photographs taken by a multiple-lens camera after the wing prints have been transformed. The wing-print negatives are of the same size as the verticals.

**Important Types of Shutter.** *Lower Shutter.*—The louver shutter is of French origin. There are two different makes. One works like a venetian blind (Fig. 84). Each fanlike slat is fastened to a series of gears made to open and close very rapidly. Another form (Fig. 85) is made up of fan-shaped blades that rotate in a circular motion fastened to radiate from the center. This type stands wear and tear but presents a grave engineering problem in trying to make it lighttight. Because of the obstruction of the leaves at all times during exposure, much of the light is lost and the camera therefore becomes slower.

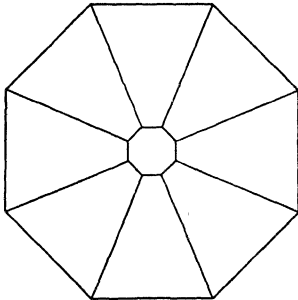

FIG. 83.—Pattern of a 9-lens composite photograph.

*Focal-plane Shutter.*—The focal-plane shutter (Fig. 86) has been in use in aerial cameras for over a decade. It consists of a curtain wound onto rods with various widths of slots to permit the light to enter for exposing the film. It is mounted just in front of the film, and the curtain rods have tension springs that can be tightened to increase the speed of the shutter. Because of the combination of the different widths of slots and the tension of the rod springs, the shutter is famous for its efficiency and rapidity. Speeds up to 1/1,000 of a second are obtainable with the focal-plane shutter.

Although it is the most efficient shutter, it is not practicable for precise mapping purposes. The shutter traveling across a large-sized negative often moves irregularly, creating what are called *shutter streaks*, which produce a distortion of image. The amount of time it takes for the shutter to travel across the film causes an

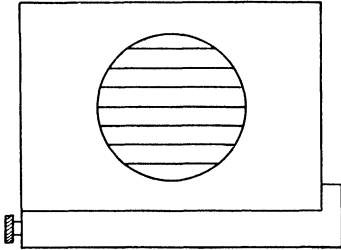

FIG. 84.—Diagram of a venetian-blind type of louver shutter.

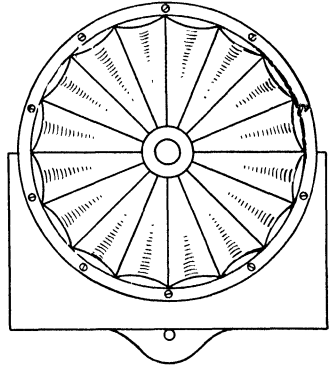

FIG. 85.—Diagram of a fanlike-shaped louver shutter.

elongation or contraction of the film image. Also the image may show movement if the picture is taken when the airplane is flown at a rapid speed or near the ground. For topographic mapping purposes, such errors inherent in a photograph cannot be compensated for.

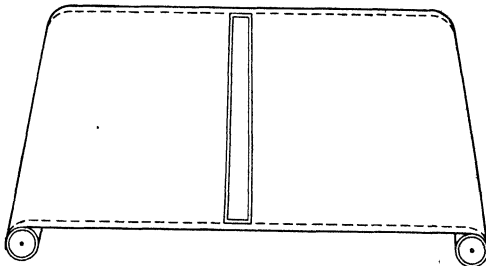

FIG. 86.—Focal-plane shutter.

*Between-the-lens Shutter.*—The between-the-lens shutter (Fig. 87) has been selected by precise mappers as being the best. It does not have the speed of the focal plane, and the leaves are quite delicately constructed; but it does expose the entire film at once, thus eliminating the distortion that would be caused by a focal-plane type. It is mounted between the elements of the lens and contains an actuating mechanism, an iris diaphragm, a tripping lever, a speed-setting arm, and several flat leaves constructed so

that while opening and closing a maximum amount of light will enter in a certain length of time. The front and rear elements are inserted or screwed into the openings provided on each side of the shutter.

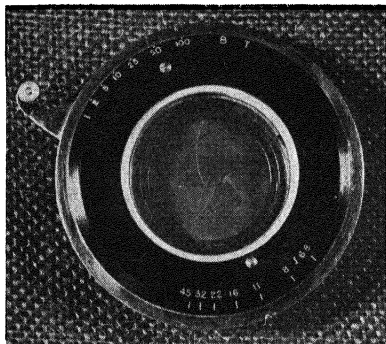

FIG. 87.—Between-the-lens shutter.

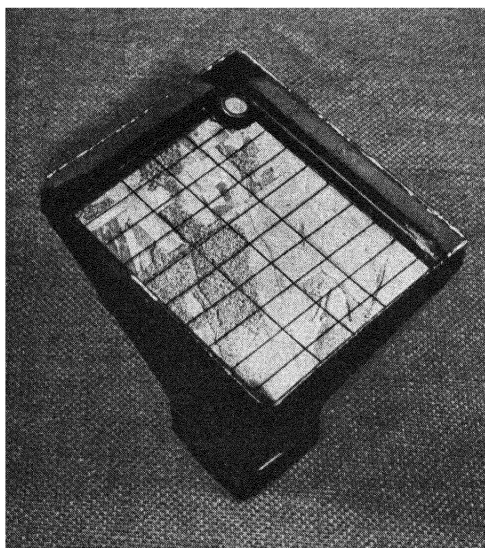

FIG. 88.—A view finder.

**The View Finder.**—The view finder (Fig. 88) is a necessary accessory for taking vertical aerial photographs. It is similar to a small camera and is mounted perpendicular to the ground near and alongside the aerial camera. It has a lens similar to that of the camera and a ground-glass focal plane marked off in rectangles. The

image covered by the camera can be seen at all times. The view finder has several purposes:

1. To determine the correct interval between exposures. Horizontal lines on the ground-glass screen enable the cameraman to time the image as it passes from one to the other. In turn he can determine the time it takes to produce a desired overlap between consecutive exposures.

2. To determine the crab and to orientate the camera properly parallel to the true flight line.

3. To check side lap and to determine scale acquired while flying at a certain altitude, provided that the view finder has the same focal length as the camera.

4. To check the flight line and the position of the airplane in relation to it.

5. To check the instant for starting and stopping the taking of exposures.

**The Intervalometer.**—The intervalometer (Fig. 89) is an electrically controlled instrument devised for the purpose of controlling the interval of exposure throughout a flight strip after it has been determined by the view finder. It can be connected with signal lamps arranged so that both pilot and cameraman can observe the instant of exposure. This provides for better teamwork.

**Altimeter.**—The altimeter (Fig. 90) is placed in the instrument panel and used by the pilot. It is absolutely necessary in making vertical aerial photographs to a certain scale. The scale desired for making a survey is figured out, and the desired altitude is determined before the airplane leaves the ground on a photographic mission. To obtain a certain scale, the airplane must be kept at a certain altitude. The altimeter should be checked while on the ground and set at the elevation of the airport before each take-off. It is always best to use a very good instrument if a precise mapping job is to be made, especially when there are several strips of the same area to be flown. Difference in scale changes created by not keeping a constant altitude will make it difficult to match the photograph images.

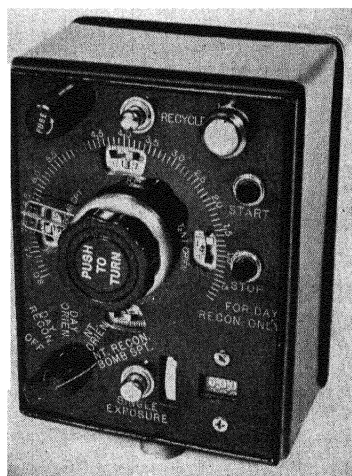

Fig. 89. —Abrams model B-7 intervalometer.

**Camera Mounts.**—In years past, much experimenting has been done in trying to perfect a camera that would operate entirely automatically. That, today, has practically become a reality. The Abrams Instrument Company has perfected an entirely automatic camera mount (Fig. 91) and a B-7 model intervalometer (Fig. 89), which is used in conjunction with the automatic camera mount for controlling the interval between exposures. Camera mounts in the past were mounted in rubber shock absorbers to the floor of the cockpit of the plane and were round to allow the body of the camera to be inserted. In the new type of mount, the camera can be oriented or tilted in any direction to remove the crab and tilt of the airplane. A camera using such a mount can be placed in an inaccessible place and operated by remote control. In military

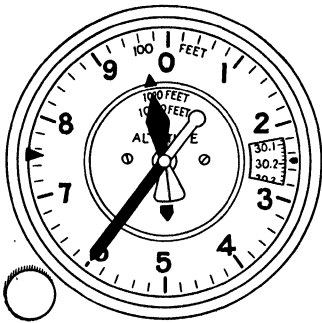

FIG. 90.—Diagram of a sensitive altimeter.

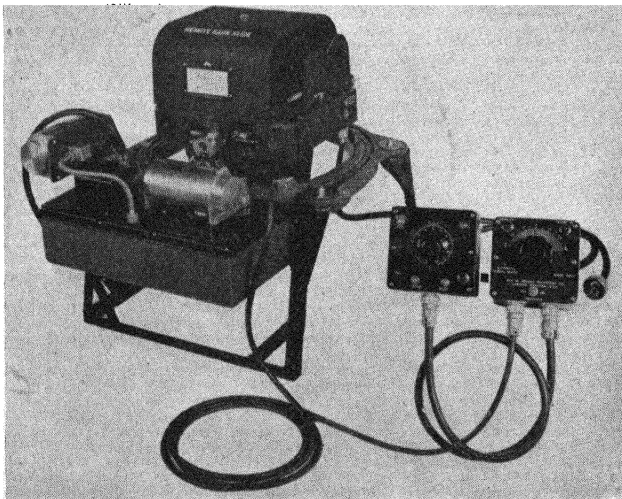

FIG. 91.—Abrams automatic camera mount holds camera vertical in flight, correcting for airplane's tip and tilt.

mapping, the camera can be mounted on a wing or in the bomb bay, and an operator is not needed. An airplane doing reconnaissance work over enemy territory needs to be able to climb out of range of

antiaircraft fire and to fly fast enough to outrun enemy airplanes. With the automatic camera mount, the airplane can be stripped of all excess weight, such as armament and the weight of a cameraman, to give it its maximum efficiency. The actual taking of photographs is controlled by the pilot, who needs only to push a button that sets all the automatic control devices in operation. The interval between exposures is controlled by the intervalometer, and the camera is corrected by remote control for crab and automatically for tip and tilt.

**Other Devices.**—Several other devices and instruments are being used to improve the making of aerial photographs. Some are a necessity on certain jobs, and others are merely for the convenience of the pilot or cameraman.

1. Oxygen equipment becomes a necessity on a photographic mission if the altitude is to be over 15,000 ft.

2. The solar navigator is an instrument used to make flying practicable over long flight lines and over difficult terrain where maps are indistinct or inaccurate.

3. The stratoscope is an instrument used in the place of the altimeter and is much more sensitive, enabling the pilot to maintain a more constant level.

4. Signal apparatus is often used with very good results in producing teamwork between the pilot and the cameraman. The signal is devised to give a warning before an exposure is made so that the pilot can level off and the cameraman can level up the camera.

### HOW TO FIND THE SCALE OF PRINTS

**Scale.**—The scale of any photograph or map is a ratio of the distance on the print or map to the distance on the ground. There are three ways of expressing scale.

#### *Representative Fraction*

$$S = 1:20,000$$

This means that one unit on the map is equal to 20,000 units on the ground. Since the map is usually measured in inches, 1 in. on the map equals 20,000 in. on the ground. This is the best method of expressing scale and is used in most published maps.

#### *Words and Figures*

$$\begin{aligned} 1 \text{ in.} &= 1 \text{ mile} \\ 1 \text{ in.} &= 500 \text{ ft.} \end{aligned}$$

This means that 1 in. on the map is equal to 1 mile, or 1 in. equals 500 ft. on the ground.

*Graphic Scale.*—With the graphic scale (Fig. 92) the distance is taken from the map with a pair of dividers and measured off by matching it on the scale. The method of constructing these will be described later.

There are several formulas that deal with the scale of aerial photographs. The first one is that the scale is equal to the print



FIG. 92.—Graphic scale.

distance between two points divided by the ground distance between the same two points.

The formula is written

$$S = \frac{PD}{GD}$$

where  $S$  = scale.

$PD$  = print distance.

$GD$  = ground distance.

*Example 1.* The distance between two road intersections is 5,824 ft. The distance measured on the photograph between these same two roads is 3.4 in. What is its scale?

$$S = \frac{PD}{GD}$$

$$S = \frac{3.4}{5,824}$$

Since scale is usually expressed as 1 to some number, we divide the denominator by the numerator.

$$5,824 \div 3.4 = 1,713$$

The scale is 1 in. = 1,713 ft.

To change to a representative fraction, multiply the feet by 12 to change to inches.

$$12 \times 1,713 = 20,556$$

$$S = 1:20,556$$

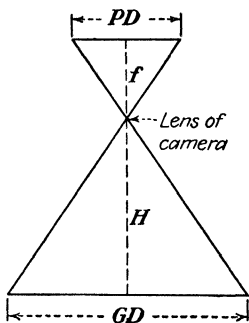

FIG. 93.—Geometric basis of the camera law.

**Camera Law.**—Since the aerial photograph is based upon light rays, we can use the camera laws in determining scale. It can be proved by simple geometry that the relationship shown in Fig. 93 is true.

It is often called the *scale proportion*.

$$\frac{PD}{GD} = \frac{f}{H}$$

where  $PD$  = distance on print.

$GD$  = distance on ground.

$f$  = focal length of camera.

$H$  = altitude of plane above ground.

Since the scale equals the print distance divided by the ground distance, the scale must also equal the focal length divided by the altitude.

*Example 2.* Find the scale of a print if the photograph was taken with a camera having a 10-in.-focal-length lens and flown at an altitude of 8,000 ft.

$$S = \frac{f}{H}$$

$$f = 10 \text{ in.}$$

$$H = 8,000 \text{ ft.}$$

$$S = \frac{10}{8,000}$$

As explained in Example 1, divide the denominator by the numerator.

$$8,000 \div 10 = 800$$

Scale is 1 in. = 800 ft. To change to a representative fraction multiply 800 ft. by 12.

$$S = 1:9,600$$

*Example 3.* This formula is often used in flight planning in order to determine the altitude at which the plane should fly in order to produce prints of a certain scale.

A photographic crew has a camera with a 6-in.-focal-length lens. What altitude must it fly in order to produce prints with a scale of 1:20,000?

Use the formula

$$S = \frac{f}{H}$$

$$S = 1:20,000$$

$$f = 6$$

$$1:20,000 = \frac{6}{H}$$

$$\text{Cross-multiply } H = 120,000 \text{ in.}$$

Since altitude is usually expressed in feet, we divide the inches by 12.

$$H = 10,000 \text{ ft.}$$

These three formulas are the most commonly used in finding scale and distances on the prints or ground.

$$S = \frac{PD}{GD} \quad (1)$$



$$S = \frac{f}{H} \tag{2}$$

$$\frac{PD}{GD} = \frac{f}{H} \tag{3}$$

*Steps in finding scale:*

- Step 1. Determine whether to use formula (1) or (2).
- Step 2. Substitute values in formula.
- Step 3. Divide the denominator by the numerator.
- Step 4. The scale is 1 to the answer of step 3.

*Steps in finding print distance:*

- Step 1. Determine whether to use formula (1) or (3).

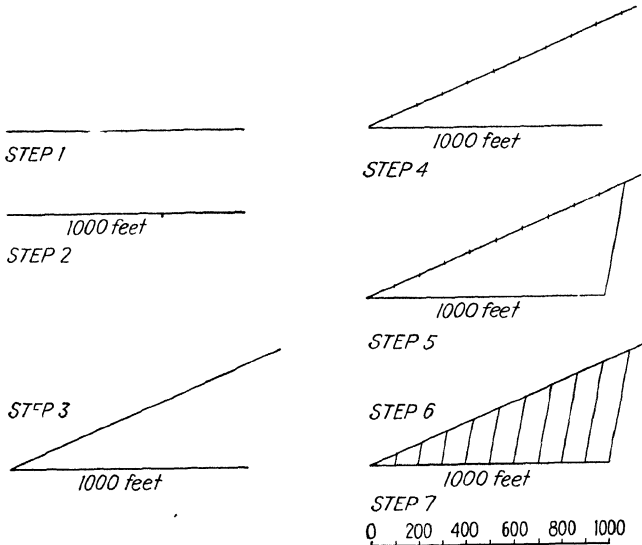

FIG. 94.—Constructing a graphic scale.

- Step 2. Substitute values in formula. Remember to express the scale as a factor.
- Step 3. Cross-multiply.
- Step 4. Solve for print distance.

*Steps in construction of graphic scale:*

- Step 1. Lay off the print distance on straight line.
- Step 2. Label that distance with the number of feet or any other unit on the ground that distance represents.
- Step 3. Construct a line at any convenient acute angle from one end of the line made in step 1.

Step 4. Mark off the line constructed in step 3, in the number of divisions wanted in the graphic scale. If the distance in step 2 is 1,000 ft. and 100-ft. divisions are wanted, divide the line (step 3) into ten equal divisions.

Step 5. Connect points on the end of the two lines (steps 1 and 4) with a line.

Step 6. Draw lines parallel to the line drawn in step 5 through the division marks made in step 4.

Step 7. Label each intersection by the proper ground distance.

### VERTICAL PHOTOGRAPHY

**Planning the Flight.** *Specifications.*—A photographic mission originates with the need or desire for a set of photographs for a specific purpose. The purpose of the photographs largely determines the specifications or requirements.

*Scale.*—In most photographic missions, the prime requirement is the desired scale. The scale depends on the purpose for which the photographs are to be used. Scales range from 1:2,000, for large-scale maps when it is necessary to identify a large number of small objects or for detail planning, to 1:40,000 and smaller, for a general study of a large area or for planning that does not require smaller detail.

*Focal Length.*—Almost any convenient focal length of lens can be used, provided that the altitude as determined by scale and focal length does not exceed the ceiling of the aircraft. If the photographs are to be used with stereoscopic plotting instruments, a short focal length, possibly 6 or 8.25 in., should be used. The longer focal lengths should be used if the prints are to be pieced together or enlarged.

*End Lap and Side Lap.*—End lap is the overlap of the photographs in line of flight and for almost all cases is specified as 60 per cent and not less than 55 or more than 70 per cent. The end lap specifications seldom vary.

Side lap is the lapping of the photographs in one flight with an adjacent parallel flight. Side lap varies from 15 to 50 per cent depending on how the photographs are to be used. For mosaic work a large side lap is desirable, but the trend is toward a side lap of about 25 per cent, which is enough for mosaics and allows more coverage. When a method of secondary control, such as mechanical triangulation, is to be used, the shorter side laps are preferred.

*Direction of Flight.*—The direction of flight is usually dependent on the shape and size of the area to be mapped. An attempt should be made to keep the lines north and south, for sun glare is encountered when flying directly toward the sun in the morning and evening

on east and west lines. Select a direction that will require as few flight lines as possible, preferably toward one of the cardinal points of the compass.

**Preparation for Flight.** *Maps and Map Substitutes.*—Unless prepared maps are furnished, it will be necessary to procure and prepare the flight maps from the specifications. The most common types of map used are the U.S. Geological Survey quadrangle maps that have scales of 1:62,500 and 1:125,000. They are available for most of the United States and its possessions. Whenever they are not available, local maps from state or county departments can be obtained.

If the territory is such that no maps are available, it will become necessary to construct a map substitute. This is generally made by flying strips across the job at as small a scale as possible and about 15 to 20 miles apart, and then flying one or two strips across these to tie them together. The end lap can be around 10 per cent to cut the cost of film as much as possible. Then the flight lines are laid out on these strips and at right angles to the line of flight. The scale of the substitute is determined by focal length and altitude.

*Computing the Time Necessary for Flying a Job.*—When estimating the cost for flying a mapping job, it is important to know how many flight hours are going to be required. This can easily be figured to a close approximation after the number of flight lines have been drawn on the flight map. The time necessary for covering the area can be determined by multiplying the time required to fly one flight line times the number of lines. The speed of the airplane and the time required for turning around at the end must be considered in figuring the time required for one flight line. The length of the flight lines in miles is determined by measuring their length on the flight map, multiplying the distance in inches times the scale, and dividing by 63,360. There are 63,360 in. in 1 mile. That, divided by the speed of the airplane, will give the time required to fly the flight line.

*Example:*

Speed of airplane = 180 m.p.h. or 3 miles per min.

Turning at ends = 2 min.

Length of flight line on map = 16 in.

Scale of flight map = 1:62,500

Number of flights = 15

$$\text{Time} = \frac{16 \times 62,500 \div 63,360}{3} + 2$$

Time = 7.26 min. per flight line

15 × 7.26 = 108.9 min.

108.9 ÷ 60 = 1 hr. 48.9 min., complete flying time

*Computing the Number of Photographs Necessary for Covering an Area.*—It is necessary to know how many photographs are to be taken in covering an area to be mapped, not only for cost estimation, but also to determine the amount of film necessary to have on hand to give complete coverage.

After determination has been made as to the number of flight lines necessary for covering the area, the number of photographs needed can be closely estimated. The altitude of the airplane and the focal length of the camera determine the scale of a photograph. The scale, the required overlap, and the size of the photographs determine the number necessary for covering a flight line or area. To estimate the total number of photographs, it is best to determine the number needed for one flight first and then multiply that times the number of flight lines, provided that they do not change in length. If they do, each flight should be figured separately and the total added.

The overlap plays an important part in the number of pictures needed. Sixty per cent overlap is the proper average for good stereoscopic coverage in the line of flight. That leaves 40 per cent of the width of the photograph for actual ground coverage between the overlaps.

The width of the negatives also make a difference in the number of photographs needed in a line of flight to give 60 per cent overlap. The overlap of 9- by 9-in. photographs covers more than those of 7 by 9 in., and therefore fewer are needed to give proper overlap in a flight line.

*Example:*

Length of flight line on map = 16 in.  
 Scale of flight map = 1:62,500  
 Length of flight line = 15.78 miles  
 Overlap = 60 per cent  
 Size of photograph = 7 by 9 in.  
 Scale of photograph = 1:20,000  
 Number of flights = 15

$$\text{Number of photographs for one flight} = \frac{16 \times 62,500}{7 \times 0.40 \times 20,000} = 17.86$$

Add a photograph to each end of the flight for complete stereoscopic cover.

$$17.86 + 2 = 19.86 \text{ or } 20 \text{ photographs per flight}$$

$$15 \times 20 = 300, \text{ the number of photographs necessary to cover the entire area plotted on the flight map}$$

If the flight lines were 15.78 miles long, as in above problem, and the flight lines were 2 miles apart, the area would be approximately 505 sq. miles.

$$15.78 \times 2 \times 16 = 505$$

*Placing Flight Lines on the Map.*—In placing the flight lines on the map, it is necessary to know the scale of the map, the focal length and plate size of the camera, the altitude at which the mission is to be flown, and the side lap desired.

*Example.* Assume we have an area 20 miles wide to be flown at an altitude of 20,000 ft. with a 6-in. lens. The plate size of the camera is 9 by 9 in., a side lap of 25 per cent is desired, and the map scale is 1:62,500.

Determine the scale of the photograph by the formula

$$\frac{\text{Focal length}}{\text{Altitude}} = \text{scale} \quad \frac{6}{20,000 \times 12} = 1:40,000$$

Then, taking 25 per cent of the width of the plate, or

$$9 \text{ in.} \times 25 \text{ per cent} = 2.25 \text{ in.},$$

subtract from the total width of the plate:  $9 - 2.25 = 6.75$  in., the distance between flight lines.

Using the formula  $\frac{\text{Photographic distance}}{\text{Map distance}} = \frac{\text{photographic scale}}{\text{map scale}}$ , we can set up the following problem:

$$\frac{6.75 \text{ in.}}{X} = \frac{1:40,000}{1:62,500} = 4.32 \text{ in.}$$

which is the distance between flight lines on the map at a scale of 1:62,500.

Now we not only have to have 25 per cent side lap between flights, but our first and last flights must overlap the boundaries of the job by 25 per cent. Therefore

$$\frac{2.25 \text{ in.}}{X} = \frac{1:40,000}{1:62,500} = 1.44 \text{ in.}$$

which is the distance we place our first line away from the edge of our project. Place the first line 1.44 in. from the left-hand side of the area and plot flight lines across the job at intervals of 4.32 in. and parallel to one another. This would give us five flight lines with the last one overlapping the boundary slightly more than 25 per cent.

Figure 95 is a reduced example of the preceding problem with two photographs superimposed to illustrate side lap.

*Installation of Equipment.*—1. Preceding the flight it is the duty of the cameraman and pilot to check all equipment and to install the camera and accessories in the plane. It is the pilot's duty to see to the airplane and instruments, while the photographer installs the camera and accessories. The film supply should be enough or slightly more than the project requires.

2. The pilot and cameraman should then discuss the work at hand and should make definite plans as to the procedure to be followed and the signals they will use. They should study the map and know all the prominent features of the area that can be used for reference points.

**Flight Procedure.** *Duties of Crew during Taxi Time.*—After all preparations have been made and the weather is in agreement, the

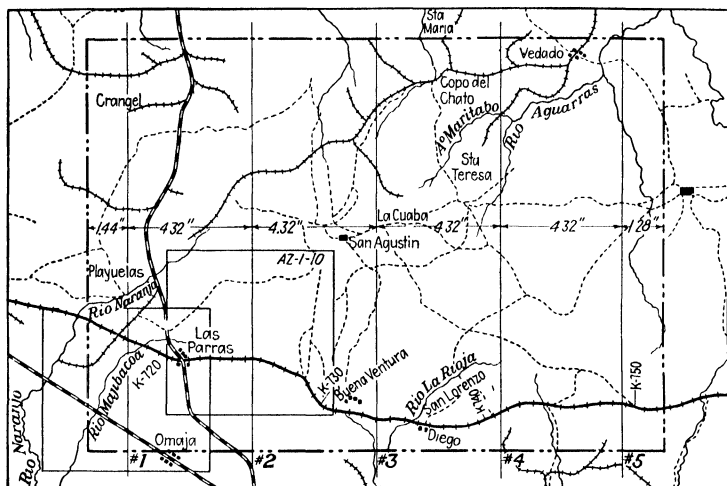

FIG. 95.—Flight map.

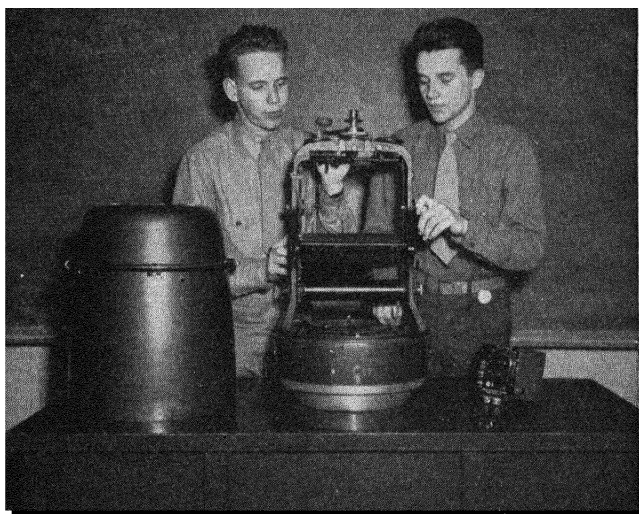

FIG. 96.—Preparing the camera for loading film.

crew proceeds to the job; from the time the plane leaves the ground the crew is busy preparing for the work. The camera should be placed in the mount and the view finder checked so that the instant

they are over their objective they can proceed without delay. Time of take-off is recorded along with pertinent information related to the flight. If the flight is to be over 12,000 ft. for any length of time, oxygen should be checked and the flow adjusted.

*Procedure on the Job.*—All preparations having been made either on the ground or during the trip to the project, it should be possible to start the first flight line as soon as the airplane is at mapping altitude and is over the project.

The pilot will level the airplane and compensate for drift a short while before he reaches the start of the flight. This will give the cameraman time to check the interval between exposures and adjust the camera to compensate for the crab of the airplane due to drift.

When the pilot and photographer are ready to begin, they pass a prearranged signal. The photographer then levels his camera and takes his first picture, making exposures at regular intervals and checking the flight line in his view finder until the boundary of the project is crossed. He then signals the pilot, and the pilot makes his turn to line up on the next line, where the same procedure is followed. This continues until the project has been completed.

**Recording the Flight.**—To record the details of the flight and the photography accomplished, it is customary to file a record of each separately.

#### Flight Record.

1. Time of take-off.
2. Time of landing.
3. Taxi time.
4. Photograph time.

#### Record of Photography.

1. Name and location of project.
2. Camera type and number.
3. Lens type and number.
4. Date and time of start and stop of each flight.
5. Camera meter readings.
6. Direction of flight.
7. Exposure time.
8. Any remarks that may aid in processing.
9. Weather conditions.
10. Names of crew members.

As unimportant as some of these may appear, they may aid materially in the processing of the photographs. Whenever possible, a flight map should be sent with the film to the laboratory.

Aerial Survey Report								
Project <u>City of Lansing</u>		ABRAMS AERIAL SURVEY CORPORATION Lansing, Michigan			Roll No. <u>3</u>			
State <u>Michigan</u>		County <u>Ingham</u>	Camera No. <u>F-4-4-22</u>	Lens Speed and No. <u>F4.0 131361</u>				
DATES	FLIGHT STRIPS	METER READING	DIRECTION OF FLIGHT	TIME START	STOP	EXPOSURE TIME	VISIBILITY	REMARKS
11/8/40	1	23260 - 281	N	11:15	11:19	1/160 f11	30 mi.	
"	2	23282 - 303	S	11:21	11:24	"	"	
"	3	23304 - 323	N	11:26	11:30	"	"	
"	4	23324 - 346	S	11:34	11:37	"	"	
"	5	23347 - 366	N	11:40	11:44	"	"	
"	6	23367 - 389	S	11:50	11:53	"	"	
Indicate on Reverse Side Position of Breaks in Flight Lines and End of Flights.								
Altitude :- 3750'								
Focal length - 8.25"								
				Pilot <u>John Doe</u>				
				Plane <u>Cessna NC17087</u>		Photographer <u>Joe Smith</u>		

Form 12.—Typical flight-record card.



### OBLIQUE PHOTOGRAPHY

Oblique photography is less exacting than vertical photography, inasmuch as few specifications are made. Illustrative purposes, record, and intelligence are the principal uses of oblique photographs. A long-focal-length camera is preferable for two reasons: less distortion is contained in the photograph, and safer altitudes may be maintained in the flying.

For illustrative purposes, an angle should be chosen that will show the subject in its best form and yet show all the installations.

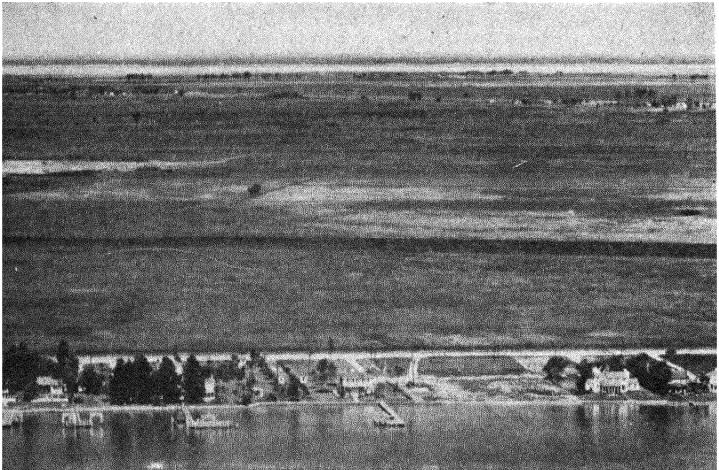

Fig. 97.—An aerial oblique photograph showing lake-front property.

Illumination should be such that some shadows are visible. Shadows give depth to the photograph.

For record and intelligence purposes, the angle should be such as to show all the installation. Several different angles should be covered, usually from the four cardinal points of the compass.

It is usually desired to have the horizon show, and about one-fifth of the view should be sky.

**Flight Maps.**—It is not necessary to plot flight lines on the map unless a long area is to be covered with a series of oblique photographs. Locations are generally marked, and angles are marked on the map after the photographs are taken.

**Flight Procedure.**—Either the door of the airplane should be equipped with a removable window, or the door must be removed prior to take-off to afford a clear unobstructed opening from which to make the photographs. Upon reaching location, the pilot flies

diagonally to the facing of the desired view and slightly above the prescribed altitude. When he nears the point at which the photograph is to be made, he cuts the throttle, reduces the airplane's speed to a minimum, and steadies the airplane. As soon as the photograph is made, the cameraman signals, and the pilot makes his getaway.

Flight and photographic records must be maintained in the same way as in vertical photography for the purpose of identification and as an aid in numbering and titling negatives.

Procedure in oblique photography is entirely up to the crew, and good photographs are dependent on careful planning and quick thinking at the location.

### LABORATORY PROCEDURE

**Chemistry of Photographic Processing.**—When a photograph is taken, light causes a chemical reaction on minute particles of silver halide suspended in the gelatin emulsion of the photographic film. This chemical reaction tends to reduce the silver halide to a metallic silver stage. Although it is not visible to the naked eye, we have a latent photographic image on the film. It is in the laboratory that this latent image is acted upon by a developing solution that reduces the latent silver image into a black metallic silver. White objects reflecting more light expose deeper into the emulsion, thereby building up greater density in that portion of the film. Black objects reflect little or no light and expose none of the silver halide, thereby leaving a relatively clear spot in the film.

Three common developing agents are used quite extensively, pyrogalllic acid (pyro), hydroquinone, and metol. They must combine with oxygen to reduce the silver halide in the emulsion. However, they are neutral or slightly acid in their normal condition, and development would therefore be very slow. It becomes necessary then to add an alkaline sodium salt (sodium carbonate), which readily absorbs oxygen and quickens the action of the reducing agent. We find upon using our solution now that it reduces all the silver halide, making no distinction between the grains exposed to light and the untouched grains. By adding potassium bromide, we make our developer selective. The bromide forms a double coating over the unexposed silver, allowing the developer to act only upon the light-exposed silver. Because developing solutions oxidize rapidly and stain, it becomes necessary to add sodium sulphite to the solution to take up the excess oxygen, which forms sodium sulphate and acts as a preservative for the developer. It takes no active part in the development.

We can classify the ingredients in our developing solution as follows:

Reducers (developers).....	Metol Hydroquinone Pyrogallic acid
Accelerators.....	Sodium carbonate Borax
Selecter or restrainer.....	Potassium bromide
Preservative.....	Sodium sulphite

The film, after development, must be made permanent. In order to do this, we have to stop the action of the developer, dissolve out the unused silver grains, and harden the gelatin emulsion. To stop the action of the developer, which is alkaline, mild acid is used (glacial acetic acid, diluted). Hypo salts (sodium hyposulphite) release the unused silver grains, which are removed from the emulsion by agitation. For an emulsion hardener, we add potassium alum. In this solution, we must also add a preservative (sodium sulphite) to prevent decomposition of the hypo by the acid.

Breaking our fixing solution into its component parts we have:

Neutralizer.....	Glacial acetic acid Citric acid
Fixer.....	Sodium hyposulphite
Preservative.....	Sodium sulphite
Hardener.....	Potassium alum Chrome alum

**Development of the Film.** *Development.*—As soon as the film is delivered to the laboratory, it is taken to the darkroom for development. The film being in a roll ranging from 75 to 500 ft., we find it close to impossible to develop it without the use of some device or machine. There are several units for this purpose on the market, the most popular being the Smith developing kit. Agitation of the film during development is accomplished by use of an electric motor that draws the film back and forth through the developing solution. Development of large rolls of aerial film (75 ft. or longer) requires a lengthy developing time, 10 min. or more, to avoid streaks or uneven development. Fixation time is from 15 to 30 min., dependent on the age of the fixing bath. The film must be washed thoroughly to remove all traces of hypo in the negatives. The wash should be about 1 hr. in a strong flow of water with continuous agitation.

*Drying.*—After wash, the film is put on to a drying reel. To accommodate a roll of film 9 in. by 75 ft. requires a reel 3 ft. in diameter by 8 ft. in length. Film is wound spirally on the drying reel. Excess water is removed from the film with a chamois.

*Numbering.*—Numbering of the film is necessary and should be accomplished before the prints are made. Numbers are placed on the back of the film and usually on the photo image. The accepted method seems to be to put all data on the north or west edge of the film. Numbering may be done with pen freehand, with mechanical lettering sets, or with rubber numbering stamps and

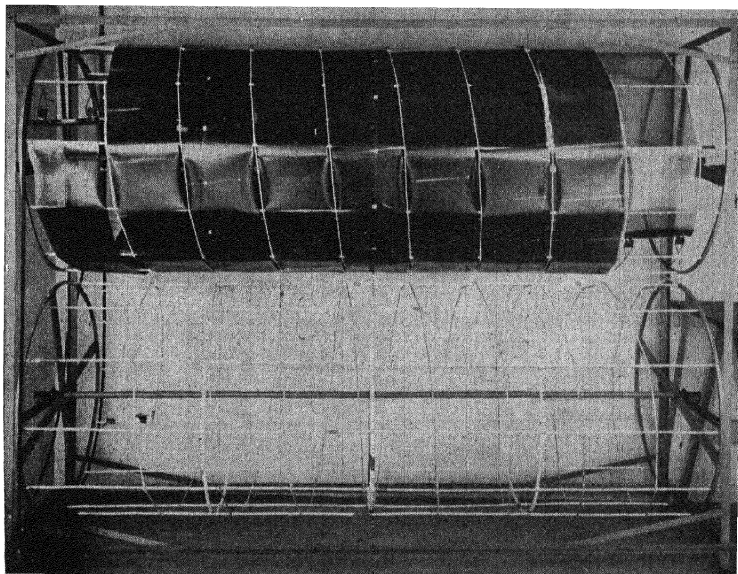

FIG. 98.—Film-drying reel.

a heavy black stamp ink pad. The information contained should include:

1. Date and time photographs were made.
2. Location or code designating location.
3. Roll number and negative numbers in the order they were taken.
4. Scale (representative fraction).

When placed on the back of the negative with opaque, letters will print white on the photograph.

*Printing.*—Photographic printing can be divided into two classifications, contact prints and projections. The name of each is indicative of the process involved. Contact prints are made by placing the emulsion surface of the photographic paper in direct contact with the emulsion surface of the negative and exposing with light through the negative. Projections are photographs made to a

larger or smaller scale than the original negative. The processing of either is similar to the processing of film, *i.e.*, development to the proper tone, fixation, and thorough washing. Drying is usually

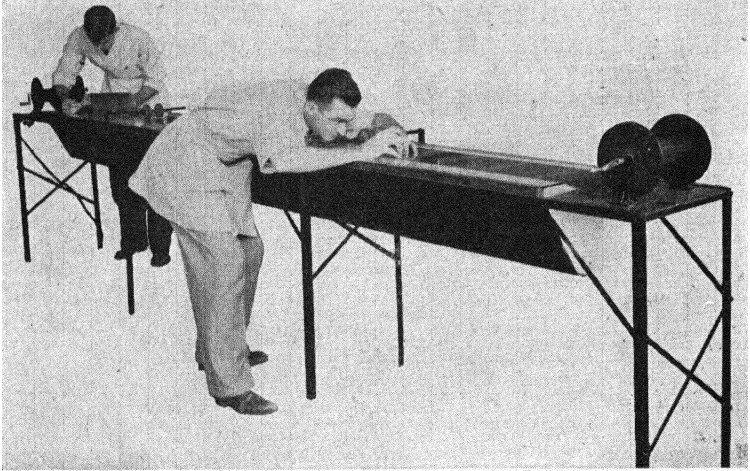

FIG. 99.—Numbering film on a shadow table.

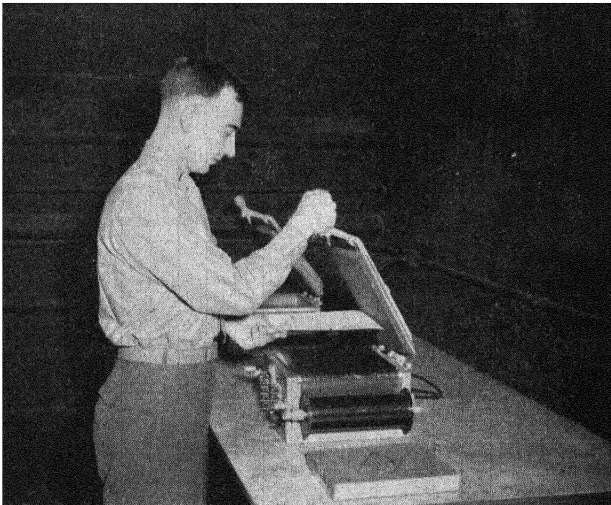

FIG. 100.—Making photographic prints with the Abrams A6-A contact printer.

done on a drying rack composed of shelves of cloth on wooden frames. A heated drum type drier hastens the work but tends to make the prints brittle, causing cracks in the emulsion.

*Trimming.*—Prints of aerial photographs are usually trimmed to the photo image. Borders are not common.

**Errors Inherent in Aerial Photographs.**—Most of this article is a review of errors that have been mentioned in previous paragraphs, but it is necessary to enumerate them in outline form for a better understanding of their existence. These errors are merely distortions of the image from its true shape and can be caused by many things beginning at the time the negative was taken.

#### *Errors Caused by the Camera*

*Lens distortion* can be caused by improper grinding and may have any of the following defects (see the Glossary):

1. Chromatic aberration.
2. Spherical aberration.
3. Coma.
4. Curvature of field.
5. Astigmatism.
6. Incorrect assembly in the cone.

*Remedy.*—Lenses should be tested by the Government Bureau of Standards and discarded if they do not reach the specifications. Always use the center portion of the prints as much as possible.

*Focal-plane shutters* do not make good shutters for precise photogrammetric mapping, owing to their many distortive effects.

1. The image is elongated or contracted in the direction of flight. The amount depends on the speed of the airplane and the speed of the shutter. The width of the slot in the focal-plane curtain times the width of the plate times the shutter speed times the distance traveled by the airplane in one second equals the amount of contraction or expansion of the detail in the line of flight.

#### *Example.*

$$\begin{aligned} \text{Plane travels } 150 \text{ m.p.h.} &= 220 \text{ ft. per sec.} \\ \text{Shutter speed} &= \frac{1}{100} \text{ sec.} \\ \text{Shutter slot} &= 1 \text{ in.} \\ \text{Focal-plane plate } &7 \times 9 \text{ in.} \\ 1 \times \frac{1}{100} \times 7 \times 220 &= 15.4 \text{ ft.} \end{aligned}$$

2. Focal-plane shutters often become sticky or worn, causing shutter streaks on the film and blurred fuzzy spots.

3. The focal-plane glass refracts the light as it travels through it, exposing the film and causing a slight distortion.

*Remedy.*—Use a precise mapping camera constructed of invar steel or some other metal which does not change its length due to temperatures, and containing a between-the-lens shutter.

*Errors Caused by Film Processing*

1. The shrinkage factor of most film is about 1 part in 600, which slightly decreases the scale of the prints.
2. Film becomes larger when wet and if not kept loose during drying will become stretched and distorted.
3. Different humidity conditions will change the expansion and contraction of film to a small degree.

*Remedy.*—Use nonshrinkable film, and pay special attention to its drying.

*Errors Caused by Print Processing*

1. Single-weight paper will shrink about 1 part in 400 when it becomes dry after processing.

2. Double-weight paper shrinks 1 part in 800 when it becomes dry after processing.

3. All photographic paper has a grain and will expand greatly against the grain but very little with it when wet. This causes much trouble in making an accurate map if the prints are used when wet. It is possible for paper to stretch as much as 0.25 in. over 10 in.

*Remedies.*—Use Positype or Air Map Special paper, which has a celluloid base, for making prints that are to be used for control, or when it is desired to maintain the scale of the negatives. Never ferrotype prints that are to be used in photogrammetry, and always make measurements or computations from the film whenever possible. Try always to keep the prints as dry as possible during assembling.

**Errors Found in Different Photographs.**—*Tilt or tip* is the error caused by the camera's not being truly perpendicular to the ground during time of exposure.

*Remedy.*—Restitute (see Chap. XIII) the photograph or use an automatic camera mount.

*Differences in Elevation Due to Relief*

*Remedy.*—Restitute certain portions of the print to a common scale. Relief displacements are less near the center of the photograph.

*Difference in Scale between Consecutive Photographs or Flights*

*Remedy.*—Check the accuracy of the altimeter, and restitute the existing photographs if they are to be used to known measurements.

## CHAPTER VIII

### STEREOVISION

**Purpose of Stereoscopy.**—It is very important from a military standpoint that ground information on distant or enemy territory be obtained by some means other than personal reconnaissance. This can be done, and is being done, without visiting the areas, by the use of overlapping (stereoscopic) pairs of vertical aerial photographs.

This comes about when an airplane flies over an area, taking photographs with the axis of the camera lens vertical. The exposures are taken so that an area on one photograph also appears on the photograph next to it. The overlapping area is suitable for stereoscopic study, which, when set up properly, shows the relief, or relative elevation and structures that appear in that area.

The photographs should be placed in the position in which they were taken. If improperly viewed, the relief will appear in reverse, *i.e.*, the valleys will appear to be ridges and the mountain peaks appear to be pits, producing what is called *pseudoscopic effect*.

**Methods of Seeing Stereoscopically.**—The stereoscopic study of a pair of overlapping vertical photographs may be made with the eyes unaided, with plain magnifying spectacles, with one's own spectacles, with a folding pocket stereoscope using a meniscus type lens, or with a mirror and prism stereoscope. For use in the field, small folding stereoscopes can be obtained. Those who have mastered the art of stereovision need only magnifying spectacles.

*Without Instruments.*—To master the art of stereoscopic vision with the naked eyes, it is necessary that you understand the scientific principles involved, and that you be able to focus your eyes at a distance and yet see a double image of an object held at ordinary reading distance from the eyes.

You must also have patience and perseverance. Many persons have mastered the trick only after having worked 15 to 20 hours with stereo-prints. Once mastered, stereovision is both interesting and enjoyable.

*Methods of Approach to Stereoscopy.*—There are several methods of approach to the subject of stereovision, and the difficulty lies in selecting for the novice the exact technique that will best cause



the relief to register with him. So startling and revealing is the effect, when he does get it properly, that fascination furnishes the incentive to further practicing.

Remember to maintain your gaze focused on distance while doing stereo-work. This may be likened to assuming a blank stare or "glassy" stare, going into a trance, stargazing, or daydreaming. The condition of having the eyes out of focus may be likened to the effect produced when you momentarily try to read a paper held



FIG. 101.—A stereogram properly oriented, spaced, and placed in position.

about 3 in. in front of the eyes and suddenly remove it to ordinary reading distance without changing the focus of your eyes. In attempting to read when you are so sleepy that you can "hardly hold your eyes open," you often find the page blurred and "see double." The equivalent of this effect is helpful in stereo-work.

While focusing on a far wall of the room, bring one finger into the line of sight, and about a foot in front of the face. Close and open alternately one eye and then the other. The image of your finger appears to shift position. Still gazing at the wall, but with both eyes open, you should see two hazy images of your finger, one corresponding to each of the two positions previously noted. The ability to "see double" involves a sort of mental and muscular control over your eyes, so that you can focus or concentrate for

distance and yet discern close objects or images. If you allow yourself to focus on only one object, the other will disappear; so "keep your distance." An amusing phenomena results when you hold both hands about a foot in front of the eyes, with fists closed. Point the forefingers horizontally toward each other, with the tips about  $\frac{1}{2}$  in. apart. Gaze at the distant wall as before, and note the result.

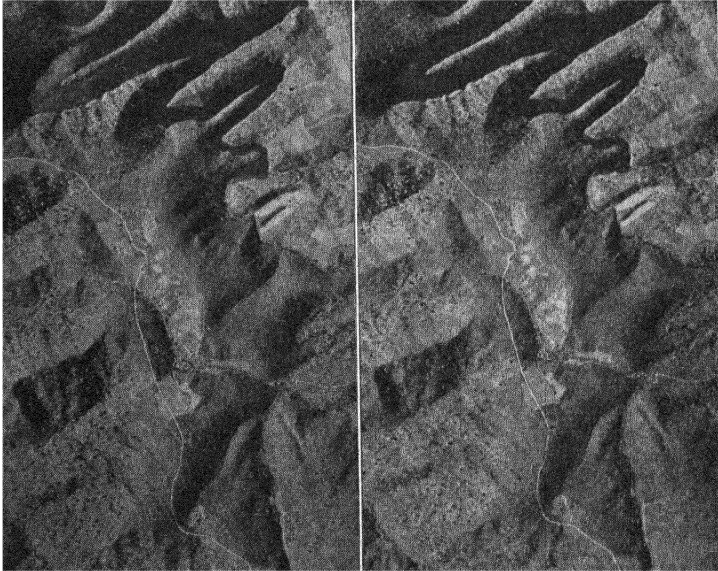

FIG. 102.—The same stereogram improperly placed in position, producing a "pseudoscopic effect."

Another step in attacking the problem is as follows: Cut some paper, so as to secure two strips about  $\frac{1}{2}$  in. wide and some 3 in. long. Lay down one strip vertically, on a contrasting background on a desk or table. Look at the strip with the left eye closed; open the left eye, and quickly note that a second image of the strip now appears to the right of the original one. Refrain from trying to focus intently on either image, but maintain the "glassy" stare. Rotate the strip slightly and slowly in the horizontal plane, with a finger against the lower end, and note that two images appear to have motion with respect to each other. This enables you to check the number of images you see. Now with the two strips on the desk, parallel and about 3 in. apart, close and then open the left eye as before. Two images of each strip, four altogether, will be in evidence

when both eyes are open. Rotate each strip slowly, and all four images seem to move with respect to one another. The strips may be held up in front of you if preferred. Discontinue rotating, and while still seeing four images, move the strip on the right slowly to the left, until the left one of its two images coincides with the right one of the two images of the left strip. A method effective with some persons utilizes a sheet of glass or the glass top of a desk as a background for the two narrow strips. Look through the glass at the floor in order to focus your eyes on distance. Still maintaining

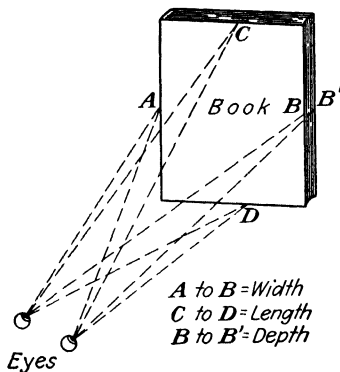

FIG. 103.—The three dimensions of a spatial model.

that focus, sweep your gaze to the strips, and make the two interior strip images coincide, by moving one of the strips. When coincidence is obtained you can see only three images instead of four. The center image (really two in coincidence) is one of the objectives you have been seeking to attain.

Mark a cross on each of the strips of paper, and resume the practice. You should see two of them for each strip, one in each strip image. Bring the two interior crosses into coincidence, as was done before, with the strip images. When you can perform this operation with facility, you are ready to try it with two narrow strips of stereoscopic photographs. You may mark a cross in identical spots on the two photographs and then make the two interior images coincide, or you may select some object (preferable brightly illuminated) that you can readily distinguish on each of the two prints. Remember that the stereo-effect is found only in the middle one of the three images; so pay no attention to the images to the right and left of the middle one. When coincidence of the photographs is secured, as above, the relief should seem to come right up and hit you.

After acquiring the knack of stereovision, you will have found that the corresponding objects on the two strips must be about 1 or possibly 2 in. apart, when the strips are properly placed, to afford clear definition without eyestrain. Having learned to secure results with the strips at this distance, practice will enable you to study a larger area by separating them slowly and retaining the relief effect

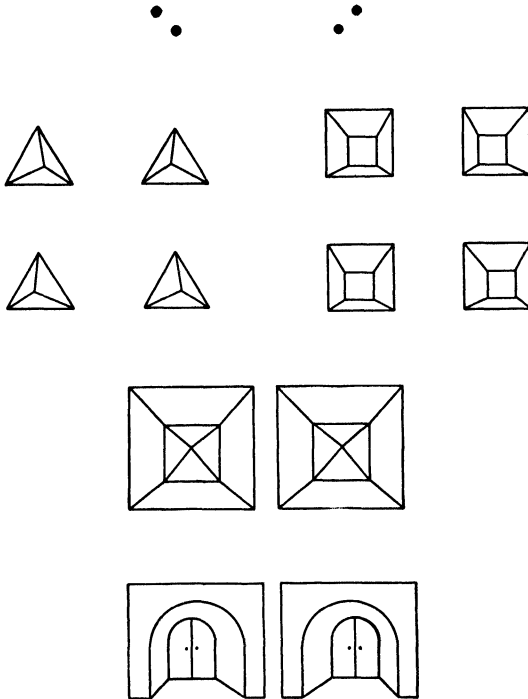

FIG. 104.—Line drawings for stereoscopic practice.

until they are so far apart that eyestrain begins and the effect is lost. Because of this limiting distance, the photographic strips should preferably be no wider than about 3 in.; otherwise there may be some areas that cannot be studied without the aid of a stereoscope. However, the narrow band along the two margins of wider prints can be studied without a regular stereoscope, provided that one print is placed so as to overlap the other; but, while bringing the two study areas within the limiting distance, care must be taken not to mask any features to be viewed. To study the left margin, the right print should be placed on top of the left one; and the left print should overlap the right one if an area along the right margin is to be studied.

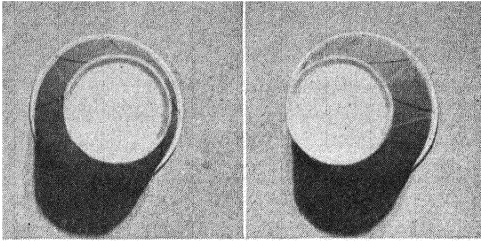

FIG. 105a. --Stereoscopic vision.

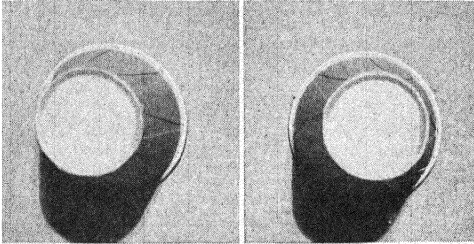

FIG. 105b. --Pseudoscopic vision.

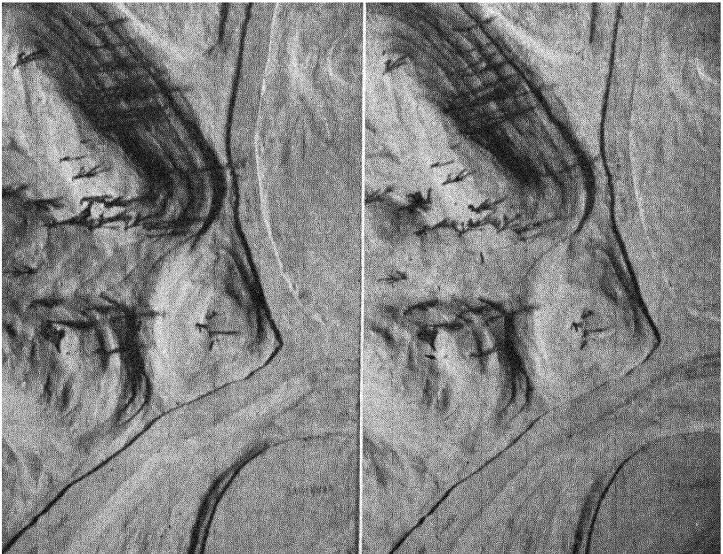

FIG. 106. --A stereogram made from a relief model.

**Theory of Stereovision.**—In order to see stereoscopically, an object must be viewed from two different positions parallel to it. A person with only one eye can never see stereoscopically, and the field of view always appears flat to him. He is able to see only width and length, and his perception of depth is only imaginative.

Stereovision is often called *seeing third dimension*. Any object that occupies space has three dimensions; (1) length, (2) width, and (3) depth. The reason we see this "third dimension," is demonstrated in Fig. 103, which shows how one eye registers the length and width of an object while the second eye registers length, width,

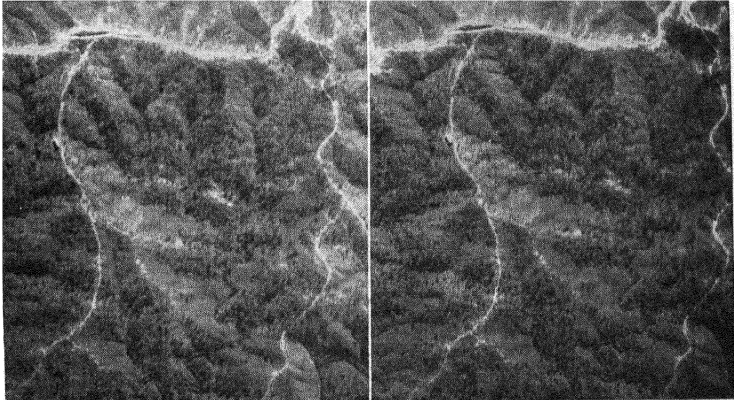

FIG. 107.—A stereogram of hills in Cuba.

and depth. It is the parallax created between  $B$  and  $B'$  that produces the effect of third dimension.

An elderly person often has much more difficulty in seeing stereoscopically than a younger one, because the muscles of the eyes have become set and will not relax so easily. Some people can never see stereoscopically from a stereo-pair but still have normal vision from both eyes and can see relief from aerial photographs if the pair has been overlapped as in anaglyphs or polaroids, which eliminate the separation of the two images so that the eyes do not have to diverge.

**Exercises.**—In Figs. 104 to 107 are a few stereo-pairs for practice in getting relief effects. They should become helpful in learning to see stereoscopically without the use of an instrument. The drawings are so spaced that, when the observer gazes for a short time at each stereo-pair, it should fuse together to produce a clear image in relief.

## CHAPTER IX

### INTERPRETATION

#### HOW TO INTERPRET AERIAL PHOTOGRAPHS

**Natural, Cultural, and Dimensional Interpretation.**—Photo interpretation is the art of identifying visible details from their images on a photographic print. The best aid to this work is the stereoscope. However, it is easy to become skilled in this work by examination of



FIG. 108.—Studying prints stereoscopically for the purpose of identifying objects.

single photographs. A reading glass will help a great deal. Skill will come by examining all types of photographs and comparing them with maps or, best of all, with the ground itself. Start with prints with a scale of 1:20,000 or larger.

**Qualities to Be Studied by Interpretation.**—Interpretation requires the study of three things:

1. Tone.
2. Light and shadow.
3. Shape and size.

*Tone.*—A large amount of light reflected from an object results in a white object on the print, and no light results in a black object. In between these two extremes are all the shadows of gray. This shade of gray of an object is known as the *tone* of the image. The less light reflected the darker will be the shade of gray, or the darker the tone. The amount of light reflected depends upon the texture of the image and the angle of the reflected light. A smooth surface



FIG. 109.—Showing graduation of tone caused by light reflection.

is generally a good reflector and will be white unless the light is reflected away from the camera. For example, if a smooth lake is photographed, much of the sunlight will be reflected. If the camera is in a position to catch the reflected rays, the lake will appear white. If, however, the light rays are reflected away from the camera, the lake will appear dark. Tone is of utmost importance when photographs are to be interpreted.

*Light and Shadow.*—When studying the photographs always face the source of light and have the shadows on the print fall toward you. This puts the light in the same position the sun was in when the picture was taken. This is very important when studying relief. Figures 110 and 111 are the same photograph, but one is reversed. Examine them and note the differences in relief.



Shadows often give the shape and size of an object that appears on a photograph. This is due to the fact that most people examine objects by their vertical dimensions, which are shown by the shadow, rather than by the horizontal dimensions, which are shown by the photograph. The top of a square building would look the same if it

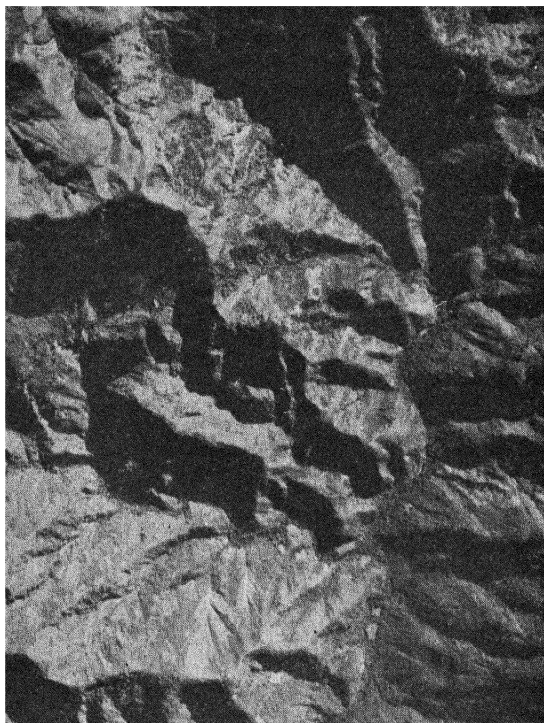

FIG. 110.—Natural relief effect.

were a one-story or ten-story building; but the shadow would be much different. The object itself may have a tone very similar to that of its surroundings, but its shadow will always be quite dark.

*Shape and Size.*—Man-made features are usually bounded by straight or curved lines, while natural features usually have irregular edges. It is important to keep the scale in mind when studying the shapes and sizes. A light square image may represent a building on a 1:4,800 print, but the same size of square may represent a cultivated field in a 1:20,000 print.

**Identification.**—On the following pages are the items and photographs that explain the identification of the most common features looked for:

*Relief.*—Relief cannot be measured from one photograph alone, but much information can be obtained. The following details tell a great deal about relief:

1. Shadows cast by hills, cliffs, banks, etc.
2. The path of streams, rivers, and lakes.
3. Ridge lines.
4. Cuts or fills in roads, and railroads.
5. Shapes of cultivated fields.

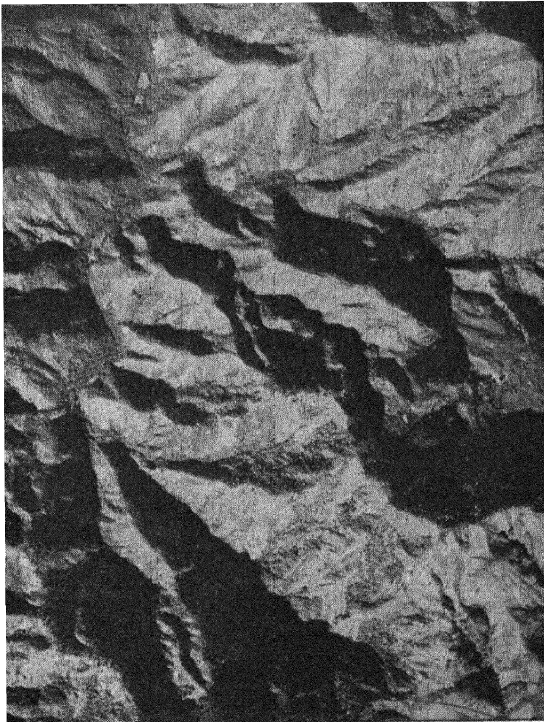

FIG. 111.—Reverse relief effect.

*Streams.*—Small streams may appear as a white or black line. They may be hidden by trees or underbrush along the side. They are usually very irregular in their courses. In wooded areas, the smaller streams may be impossible to detect. If the photographs

can be studied with the stereoscope, stream courses can be detected by the drainage lines of the area.

*Marshes.*—Marshes have a characteristic appearance. Once the operator recognizes this appearance, they are easily identified. Often there are small streams or channels flowing through them.



FIG. 112.—City area—scale 1:12,000.

Sometimes there are small areas of water in them. Marshes usually appear to be a mixture of underbrush and water.

*Bodies of Water.*—Bodies of water usually are quite black, although they may appear in any tone. They seem to have a characteristic flat surface that makes them easy to identify. The shape of the body of water is well defined, showing an irregular outline.

*Woods and Brush.*—Woods appear as darker, irregular shapes on the photograph. The season of the year must be kept in mind when studying the woods. In the summer the trees will appear as being very dark and dense; however, in the winter, with the leaves off

the trees, they will not appear so dark. The fall and winter photographs make it possible to study the detail under the trees, while in the summer the leaves hide the ground. For that reason, if it is at all possible, the photographs of wooded areas should be taken during the time of the year when the leaves are off the trees. Of course, evergreen forests show dark at all seasons. Brush has an



FIG. 113.—Portion of same area as in Fig. 112—scale 1:3,000.

appearance similar to that of forests, but a study of the shadows will show a shorter height. Since most brush areas have a few scattered trees in them, the operator should look for these and compare the shadow lengths. Orchards are distinctive, the trees being planted in regular rows and spacing.

*Cultivated Fields.*—Fields that are under cultivation stand out from other areas. They usually have a tone darker or lighter than the surroundings. The edges are straight and the corners well defined. The scale of the photograph must be kept in mind, since a small

garden in a large-scale photograph may look the same as a 40-acre field in a small-scale photograph.

*Roads.*—Roads, for mapping purposes, are usually identified as improved or unimproved roads. Roads usually appear as light lines or bands. The hard-surface roads appear whiter and have a sharper edge. The black-top roads may appear as a dark line.

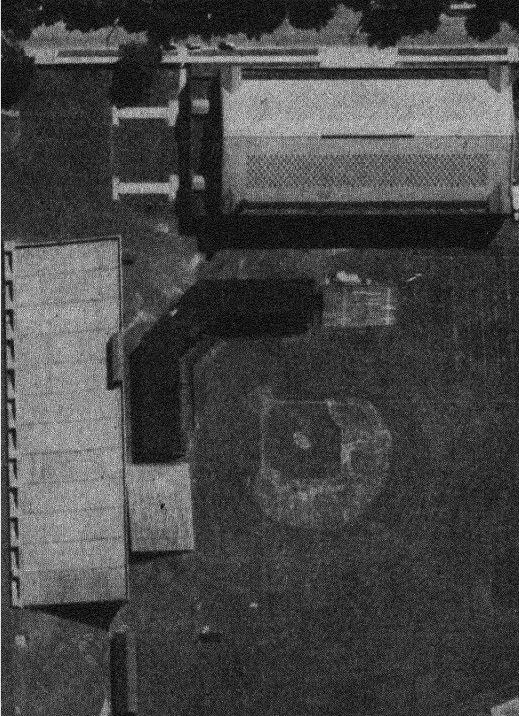

FIG. 114.—Ball diamond—scale 1:4,800.

Improved roads show straight lines between long easy curves and a regular width. Unimproved roads show irregular winding stretches between sharp curves and a variation in widths. Sometimes the trees may cover all or part of the roads.

*Railroads.*—Railroads look somewhat like roads, but they can usually be distinguished by certain characteristics. Railroads are generally darker in appearance except when crushed stone was used for fill. They are usually narrower and show much straighter lines and longer curves.

*Buildings and Structures.*—The study of the shadows plays an important part in the identification of different types of buildings and structures. The height of a building, the type of a bridge, and the shape of objects are often identified more easily by their shadows than by the object itself. Other objects, such as fences,

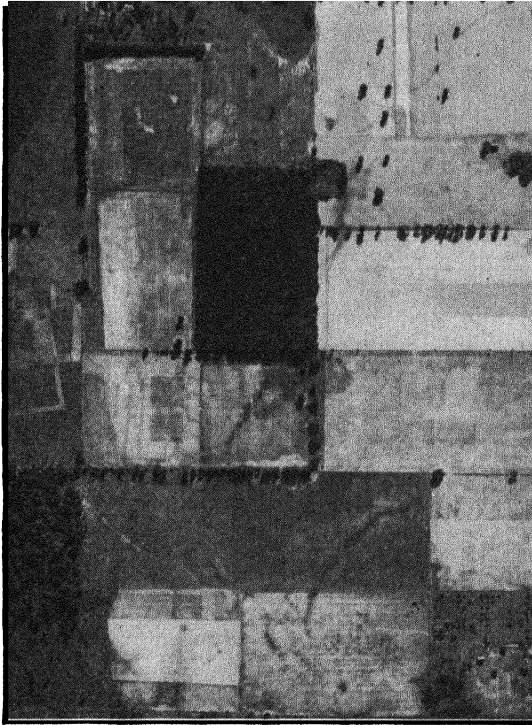
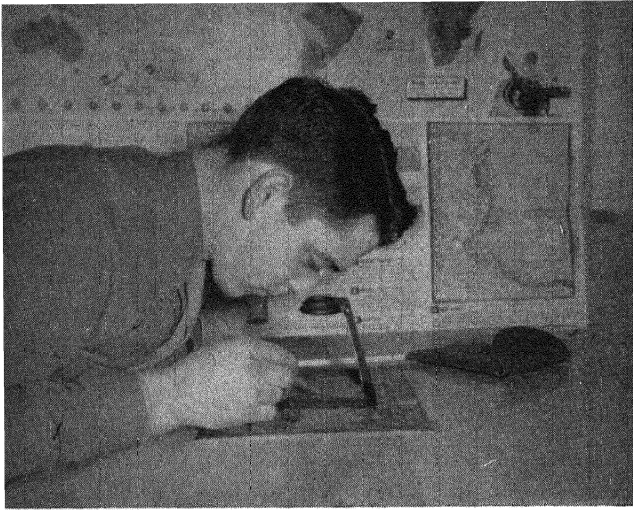

FIG. 115.—Cultivated fields—scale 1:20,000.

telephone poles, flag poles, and lamp posts, may be visible only because of the shadows they cast on the ground.

Constant practice and studying of aerial photographs is the only way to increase skill in aerial photo interpretation. The best practice is to take a photograph out into the area and study both at the same time. The next best is to study photographs of areas that are familiar. A magnifying stereoscope such as the Abrams CF-8 or Abrams B-3 (folding models) is one of the best aids to the study. Keep in mind the following points:

1. The direction from which the light falls on the photograph.
2. The shadows are very important.



**FIG. 116.**—Identifying detail with a B-3 stereoscope.

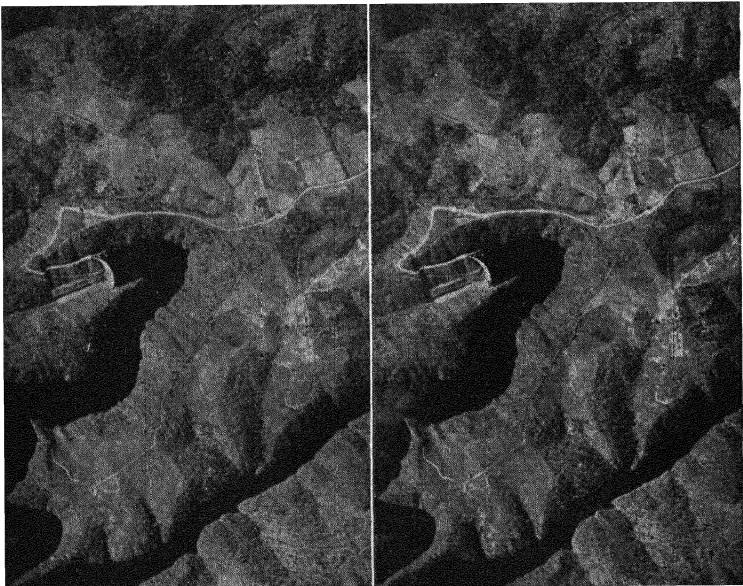

**FIG. 117.**—A stereogram showing an area with excessive relief.

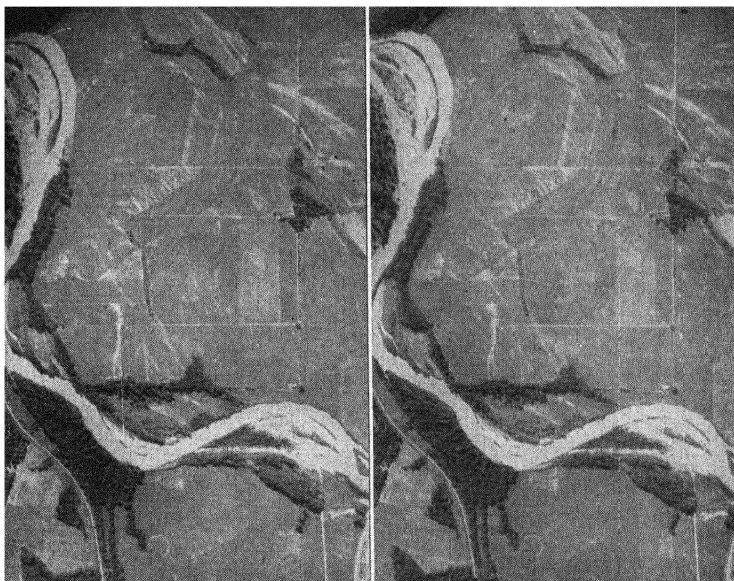

FIG. 118.—A typical muddy stream.

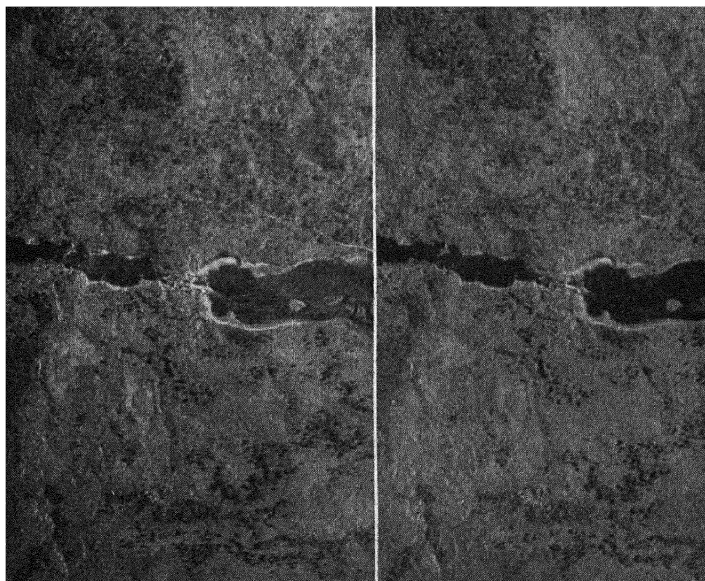

FIG. 119.—A clear stream.



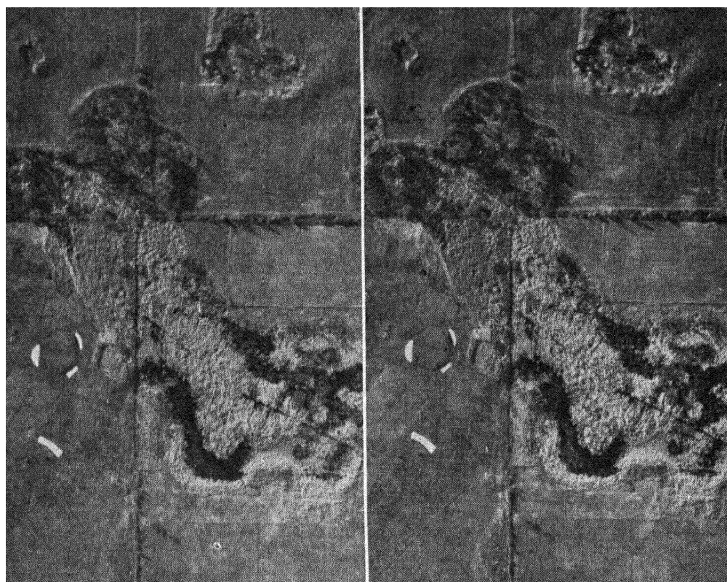

FIG. 120.—Marshland.

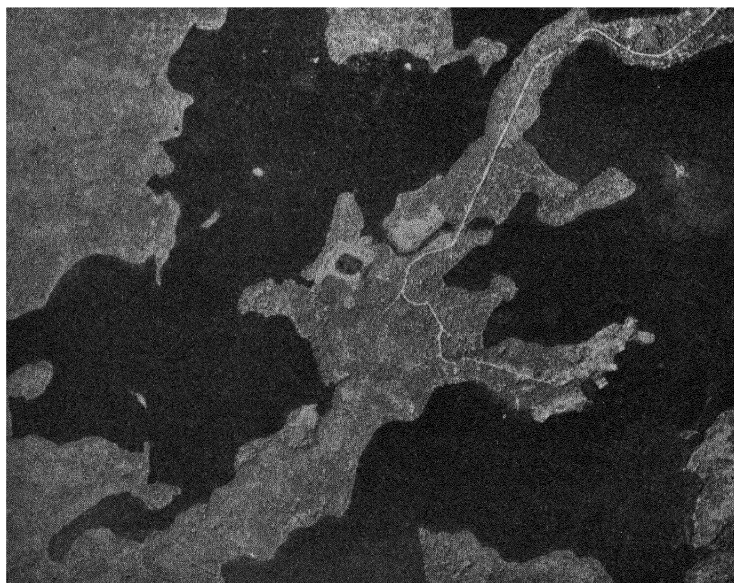

FIG. 121.—Bodies of water.

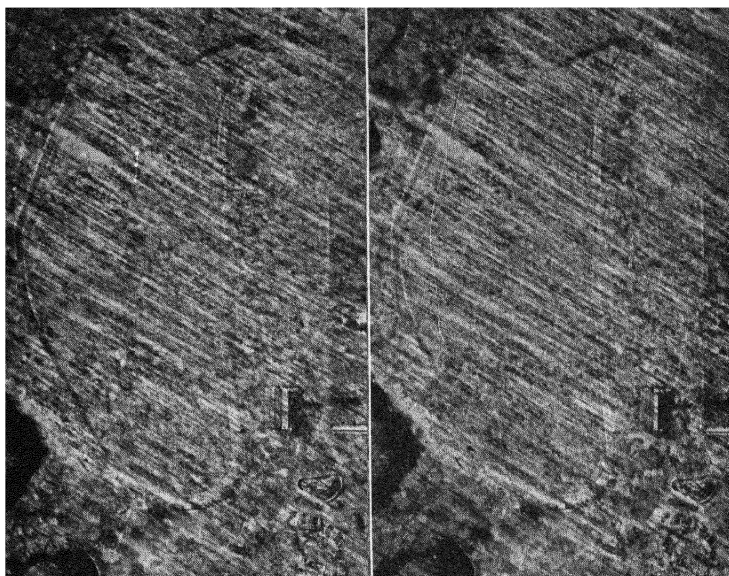

FIG. 122.—A wooded area in wintertime.

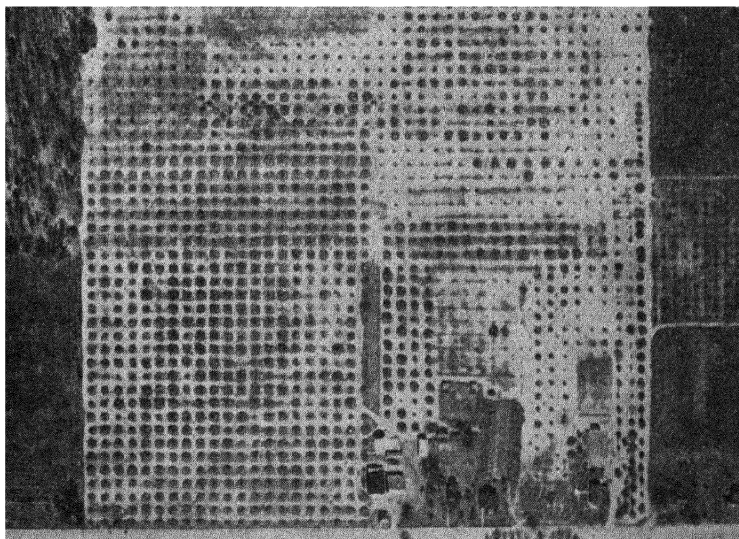

FIG. 123.—An orchard.



FIG. 124.—Cultivated fields.



FIG. 125.—Improved and unimproved roads.



FIG. 126.—Railroads and roads running through a town.

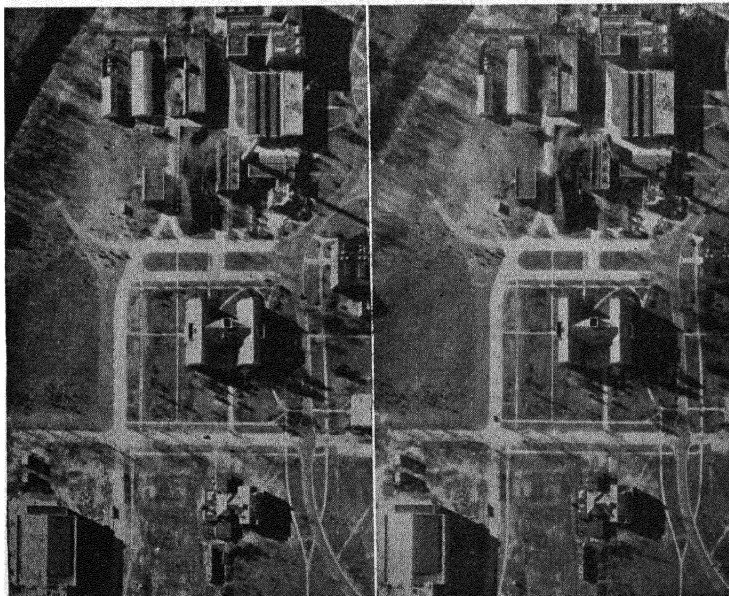

FIG. 127.—College buildings.

3. The scale of the print.
4. Use a stereoscope if possible.
5. Boundaries of natural areas are usually irregular.
6. Boundaries of man-made objects or areas are usually straight.
7. Practice at every opportunity.

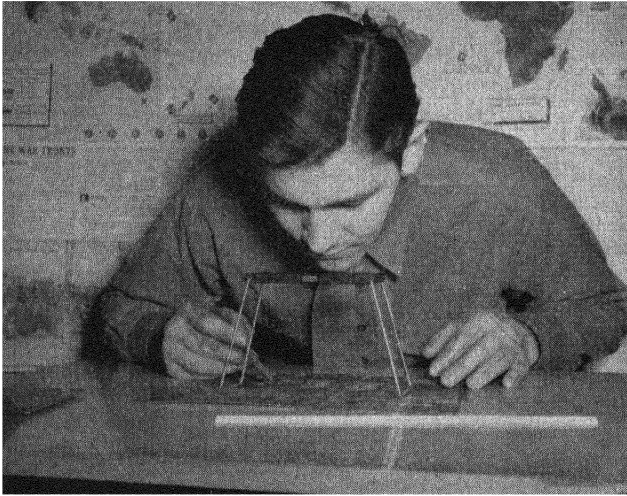

FIG. 128.—Studying photographs with a CF-8 stereoscope.

### CAMOUFLAGE INTERPRETATION

**Definition.**—Camouflage is work completed to provide protective concealment of material, troop works, or movement from enemy observation.

**Choice of Position.**—A position of an encampment, gun position, field kitchen, or the like must be located where its end use may be accomplished with ease with easy access to and natural cover for the object.

**Discipline.**—The personnel employing camouflage must be well disciplined to the end that they will do nothing to destroy or betray the camouflage by any careless act or deed.

**Selection of Material.**—To select properly the materials to be used in camouflage work, we must be familiar with them and remember that natural material is far better than artificial. These natural materials include any that may be found in a shell-torn village or field and have the advantage of being effective against all types of trick photography because they match the texture of the locality.

**Erection of Material.**—The erecting of the camouflage material should be well thought out in advance, and certain precautions should be taken to make sure that the color and texture of surrounding terrain are closely matched, that all regular forms and shadows are eliminated and all tracks of equipment and personnel concealed, and that disruptive painting is used.



FIG. 129.—A stereogram of a camouflaged area.

**Methods of Providing Concealment.**—There are three general methods of providing protective concealment:

1. *Hiding*—covering by a certain method so the object can be seen but its identity obscured.
2. *Blending*—making an object indistinguishable from its surroundings by breaking up its form and shading.
3. *Deceiving*—making an object appear to be something else and using dummies to mislead the enemy.

Methods of applying these three methods are continually changing, because the people they are intended to deceive are becoming more expert in their interpretation; but of prime importance is the ability of the interpreter to know what the genuine conditions are, or look like. If he is expert in this, he can readily pick flaws in the enemy's attempt at concealment.

**Observation.**—There are two general methods of observing camouflage.

1. *Direct*, from the ground or with binoculars from the air.
2. *Indirect*, by means of photographs.

**Kinds of Photographs.**—Three kinds of photographs may be used in this work.

1. *Panchromatic*—objects are shown in varying shades of gray—very common.
2. *Infrared*—very useful because infrared rays do not reflect from artificial coverage as they do from natural sources.
3. *Color*—where objects are registered more or less in their true color.

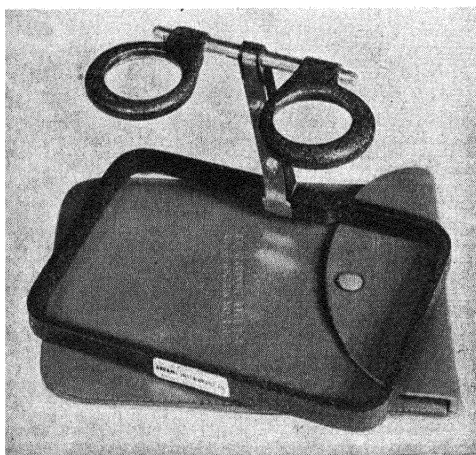

FIG. 130. —The Abrams model B-3 stereoscope.

**Photographic Characteristics.**—The interpreter must know how the genuine thing looks in a photograph. Important things to remember are

1. *Form.*—Man-made objects tend to straight lines, while nature creates in curves.
2. *Shadow.*—Shadows photograph black.
3. *Texture.*—Every object possesses a certain amount of reflectivity. The taller an object is the longer its shadow will be. A change in texture will identify a change in terrain.
4. *Color.*—Differences in color show up in color film and are also evident in panchromatic film.

**Use of Stereoscope.**—The use of the stereoscope on a stereo-pair of prints has caused a great change in the methods of applying camouflage.

A recent case is brought to mind. "The Japanese tried to divert the attention of the Allies from some important construction they were carrying on. Close by, in an open field, they build several dummy bomber planes, but did not give them any depth." They hoped to lure the allies into a trap by such tactics. However, aerial photographs taken by the Allies and studied under an Abrams stereoscope definitely showed a lack of third dimension in these bombers, proving to our air force that the bombers were put there only for a decoy. Needless to say it did not work.

**Important Characteristics.**—A person expert in photo interpretation of camouflage should also be an expert in actual ground camouflage. These two abilities are hard to attain at the same time; but they can be mastered with constant practice. One should be constantly thinking of the methods used by the camoufleurs to deceive the photo interpreter and of certain rules laid down for the camoufleurs.

*New Roads and Paths.*—Very hard to conceal. Use existing cover as much as possible. Follow fence lines or surface lines.

*Old Roads and Paths.*—Try to keep the same old appearance. Try to hide movement only.

*Railroads.*—Cannot conceal main lines. Use dummy terminals for spur lines.

*Telephone Lines.*—These may show a concealed position. New lines should be located near an old road or path, so that the tracks of maintenance crews will not be noticed.

Remember that poles make shadows. Tops of poles may be painted. If lines are buried, conceal the trench with sod or brush.

*Encampments.*—Tents should be placed under the shady side of trees. If they are in the open, avoid regular spacing. If it is necessary to camp in the open, use tents with large flat tops. Paths to latrines must be along covered routes.

*Buildings.*—Of course it is impossible, or nearly so, to camouflage large buildings. They should have a flat deck, painted with a flat dull color; however, some system of roof extension or painting may be had in order to break up the extent of the roof.

*Vehicles.*—If vehicles are in the open, cover them with nets or vegetation, try to eliminate tracks, and if possible cover them, with the idea of hiding the actual identity rather than the object.

*Machine guns and artillery* should be dug in to relieve height, and possibly covered with artificial camouflage. Try to erect dummy locations and if possible accentuate the height of dummies.

*Airdromes.*—If airdromes are new, they may be located some distance away from the clearing used as a landing field, and the



airplanes may be taxied over to the field. If this condition exists, there may be tracks resulting from the airplanes' crossing the fields. If the airdrome is already in existence, try to make it appear like the surrounding country.

*Others.*—There are many other things on which an attempt at camouflage may be made, such as airplanes, watering points, sea-coast fortifications, antiaircraft guns, and industrial points.

From the above discussions, it can be easily seen that a knowledge of the true appearance of these objects would be indispensable for a person actually trying to figure out the possible enemy deception.

Remember, when you use a stereoscope on a stereo-pair of prints that have on them a certain amount of camouflage, you have the advantage over the camoufleur. If he is a great user of dummy build-ups, they must show third dimension to be effective; and that may take more time than is available to the camouflage expert. He is always trying to achieve actual appearance by the use of artificial means, and so it is well to keep in mind the change of color. It is important that the camouflage engineer use strict camouflage discipline. This means he should leave the terrain as it is and under no condition alter it. Whenever, in successive photographs of the same area, there is a lack of such discipline shown, you can rest assured that some attempt has been made by the enemy to deceive; or unknowingly the enemy has given away an important position.

## CHAPTER X

### GROUND FORM LINES

**Definition.**—A ground form line is a line drawn on an aerial photograph showing the configuration of the earth's surface. A form line has no fixed interval and does not indicate a definite elevation.

**Characteristics of Form Lines.**—In order to understand representation of relief by form lines, a thorough study must be given to their basic characteristics. In observing form lines on an aerial photo-

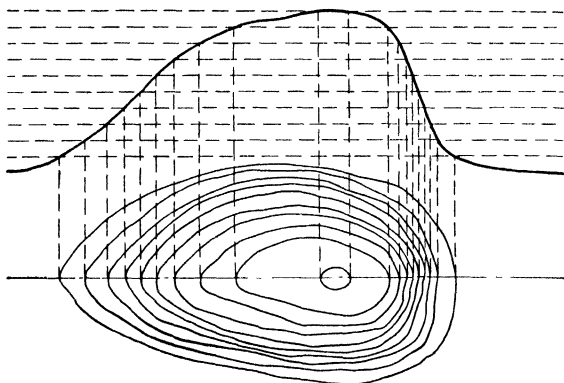

FIG. 131.—Diagram showing how contours are applied to the profile of a hill.

graph or map, the following things are usually found, as in contour lines:

1. They have a wavy appearance.
2. They are usually V-shaped in narrow valleys and U-shaped on slopes.
3. They always close, either on or off the map.
4. They are drawn at right angles to the direction of the steepest slope.
5. They are spaced directly as the variation of the slope, close together on steep slopes and far apart on gentle slopes.
6. Roughly they are parallel to the adjacent form line, as illustrated in Fig. 131.

**How to Use the Collimation Marks on a Photograph.**—Collimation marks are either on the corners or on the edge of the photograph. They are merely index marks rigidly connected with the camera lens through the camera body and forming images on the negative that define the principal point of the photograph.

With the use of a straightedge and stylus, or some sharp-pointed instrument, connect the two opposite marks in the form of a small cross in the center of the photograph.

The point at which these lines intersect is called the *principal point* of the photograph, or the mechanical center (see Fig. 132). It is important that these principal points be located very accurately, because this method is also used in the preparing of the photographs for use with the contour finder, and a fraction of an inch off center will change the position of the base line.

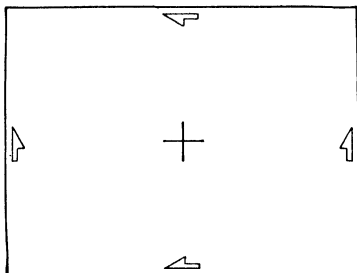

FIG. 132.—Locating the principal point.

After this operation has been completed satisfactorily, the stereoscope is taken from its case and assembled to a working position by bringing the legs down until they lock in the small groove. This holds the stereoscope rigid, and the lens will always be the same distance from the prints. Each person, before viewing a set of vertical aerial photographs with the stereoscope, must adjust for his correct interpupillary distance. This is done by a slight pull to separate the lens so that the centers of the lenses are the same distance apart as the pupils of your eyes, or about  $2\frac{1}{2}$  in.

**Transferring Principal Points with the Aid of the Stereoscope.**—There is always a number on the upper right- or left-hand corner of the photograph. Take one of the photographs and swing it around so that the numbers are on the left. Lay this print down, calling it print 1 ( $P_1$ ); take print ( $P_2$ ) and lay it over  $P_1$  matching images such as fields, streams, roads, and buildings. These images will appear on both  $P_1$  and  $P_2$  throughout the effective overlap. Notice on  $P_2$  that the principal point  $PP_2$  is showing, while the principal

point of  $P_1$  ( $PP_1$ ) is covered up by the overlap. Separate the two photographs so that the principal point of  $P_1$  is visible. Find the position of an object that is near  $PP_1$ , and separate the photographs in a straight line approximately  $2\frac{1}{2}$  in. Then set the stereoscope over the photographs so that the left lens is directly over the object in  $P_1$  and the right lens is over the same object as it appears in  $P_2$ . The area directly beneath the lens will then appear in relief. If you have picked the object near the principal point, you will also see the cross signifying the  $PP_1$  of  $P_1$ , left print. With a stylus or pin and using the right hand, reach beneath the right lens and drop the stylus to the cross as it appears on the right photograph. Upon examination, you will notice that you have put a small point in the

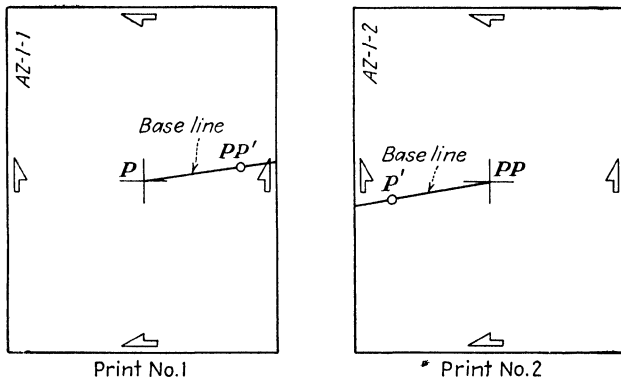

FIG. 133.—Transferring principal points and constructing base lines.

right photograph in the exact position that the two lines intersect to form the  $PP_1$  of  $P_1$ . This method is called *transferring principal points*. The operation is carried out on both photographs so that  $PP_1$  of  $P_1$  appears on  $P_2$  and  $PP_2$  of  $P_2$  appears on  $P_1$ .

**Establishing Stereoscopic Base Line.**—Using a straightedge and stylus, lay the straightedge on  $P_1$  so that it forms a straight line through the  $PP_1$  of  $P_1$  and  $PP_2$  of  $P_2$ . Connect these points with a very fine line, just indenting the surface or emulsion of the print. Do not run the stylus through the points, for it spreads the marks. It is best to start at the principal point of the photograph and draw the line to the transferred  $PP$  and then extend it to the edge of the print, as seen in Fig. 133.

**Orienting of Photographs.**—It is extremely important that the photographs be properly oriented before form lines are drawn on them. This is done by taking two photographs, laying the left print down, and taping the leading edge to the working table or

board. Take the right photograph, and lay the right print on top of the left print so that the transferred  $PP_1$  of  $P_1$  appearing on  $P_2$  is directly over the  $PP_1$  of  $P_1$ . Separate the prints along the base line so that the  $PP_1$  of  $P_1$  and its transferred point on  $P_2$  are about  $2\frac{1}{2}$  in. apart, and a straight line is formed with a straightedge laid in a position on both photographs connecting both  $PP$ 's and one transferred  $PP$ . After this has been completed, tape the right print down along the outer edge to make sure that there will be no chance of the photographs' getting out of adjustment while they are being studied.

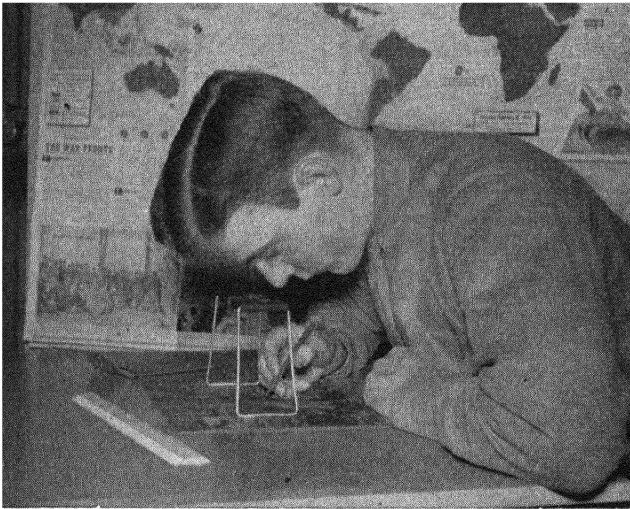

FIG. 134.—Drawing ground-form lines with a stereoscope.

**Drawing Form Lines on Photographs.**—With the stereoscope properly adjusted and set over the prints, you are ready to start the process of drawing form lines. Make a careful stereoscopic study or analysis of the terrain covered in the overlap of the photographs to fix in mind the general lay of the land. The most important things to remember when drawing form lines are (1) always keep the stereoscope parallel to the stereoscopic base line, and (2) never work or draw lines on the photographs other than directly beneath the lens. To carry this further, if you do not keep the stereoscope parallel to the base line, the spatial model that you are viewing will not be clear, and it will be practically impossible to keep your form lines at the same level. If you try to draw lines on the photographs other than directly beneath the lens, when you move to the point

where you stopped drawing, you will notice that the lines have gone either up- or downhill, when there may have been very little change in elevation.

This should be watched very closely if you are working around sudden changes of slope, crossing drainage systems, etc.

After you are convinced that you know the area quite well as to where the highest and lowest points are, you are ready to start the process of drawing form lines on the photographs, first by drawing along the principal master lines of the terrain or the principal streams

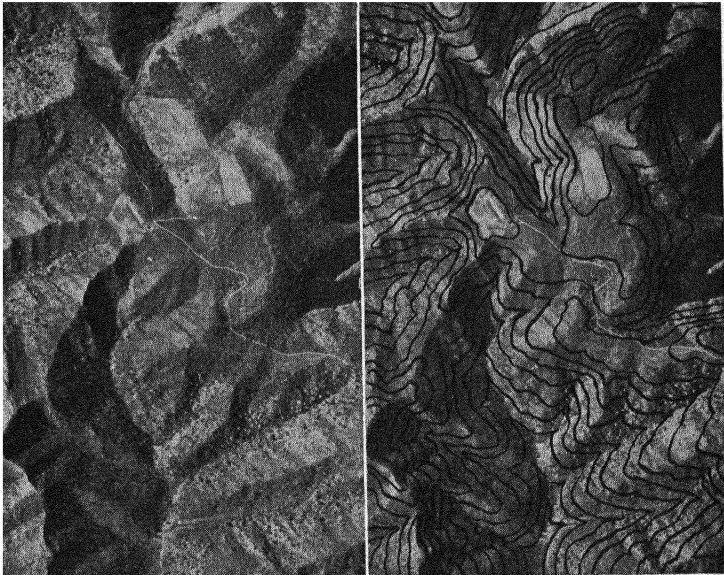

FIG. 135.—A stereogram showing ground-form lines drawn on the right photograph.

and main ridge lines. After choosing these principal streams and ridges, you extend over the minor changes in elevation and assign definite datum planes to all critical points involved. There is no set distance between the lines. They are drawn only to show, by natural terrain features, a complete elevation framework over the entire overlap of the photographs. By examination of a photograph that has the form lines, the observer will be able to locate all high points, streams, ridges, and any elevation appearing on the photographs.

**Checking Methods.**—Checking form lines for elevational errors can be done very easily by making a small circle or cross on one

print and making the same kind of mark on the other print where the first mark appears. This method is the same as that used to transfer the principal points of the photographs. When crossing drainage areas, it is a good policy to make occasional checks to assure maintainance of the same elevation.

Crosses or circles, when marked on both photographs, appear stereoscopically; and, when two or more marks are placed on each print, it is easy to see whether the elevations are the same or not.

The art of drawing ground form lines depends on the ability of the operator to acquire experience in the use of the stereoscope and also on his ability and willingness to practice constantly with the stereoscope over stereo-pairs of photographs.

## CHAPTER XI

### STEREOPLOTTING INSTRUMENTS

This chapter describes the use of two of the most common instruments now being used by our armed forces for making topographic maps—the contour finder and the multiplex aeroprojector. They have been selected for their mobility and easy operation; and the operator can become efficient within a short time if the steps are followed in sequence as they are listed.

#### THE ABRAMS CONTOUR FINDER

**How to Operate the Abrams Contour Finder.**—The contour finder is a lightweight, compact instrument, all the integral parts of which are fixed together so that it may be set up in a few seconds over a pair of vertical overlapping aerial photographs for the purpose of delineating topographic detail and determining numerous elevations. It is composed of the following integral parts:

1. Stereoscope.
2. Measuring unit.
3. Pencil arm.
4. Lighting unit.
5. Alignment mechanism.
6. Photogrammetric computer.
7. Carrying case.

**Steps in Assembling the Instrument.** *Remove from the Case.*—The instrument is carried in a small case separated into component parts. It is constructed so that it is possible to set it up without the use of any tools.

*Set Up the Stereoscope.*—Set up the stereoscope by rotating the arm away from the base, and then rotating the lenses upward until they snap into position.

*Adjust for Interpupillary Distance.*—Slip the eyepieces holding the lens along the supporting bar to adjust for the interpupillary distance of the eyes.

*Assemble the Measuring Unit to the Stereoscope.*—(1) Push the end-piece on the left side against the small gauge and hold it there. (2) Put the dowel pins on the right end under the X axis dial, into holes prepared in the base of the stereoscope. (3) Lower the left end-



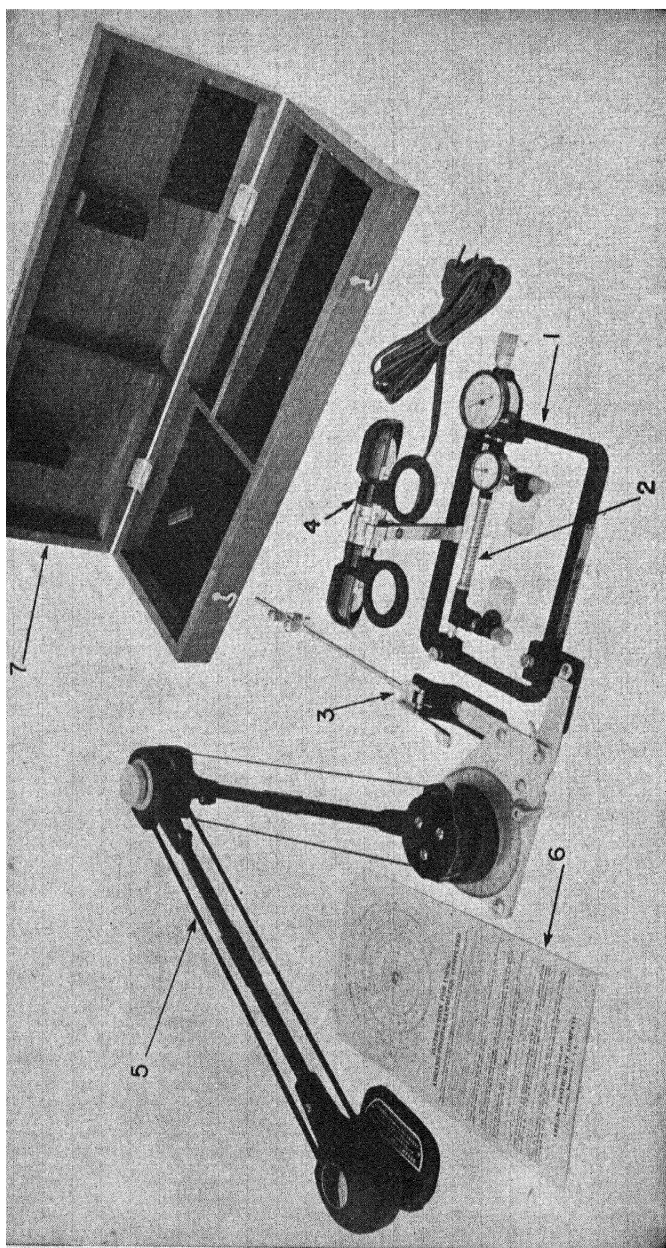

FIG. 136.—The Abrams contour finder.

piece to the stereoscope base, and release the dowel pins into the dowel holes.

*Attach the Alignment Mechanism to the Table.*

*Assembly.*—Assemble the stereoscope assembly to the alignment mechanism by means of the adapter clamp.

*Drawing Unit.*—Attach the drawing unit to the alignment mechanism.

*Lighting Unit.*—Snap on the lighting unit to the vertical arm of the stereoscope.

**Steps in Preparing the Photographs.** *Principal Point.*—Accurately locate, and prick with a pin point, the principal point of each photograph, made by intersecting lines drawn from the fiducial marks.

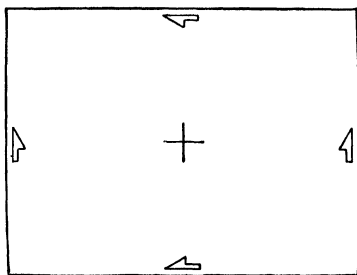

FIG. 137.—Principal-point location.

*Transfer of Principal Point.*—Transfer and prick the principal point of each photograph as it appears in the adjacent print. The use of the stereoscope will enable the operator to identify these points more accurately.

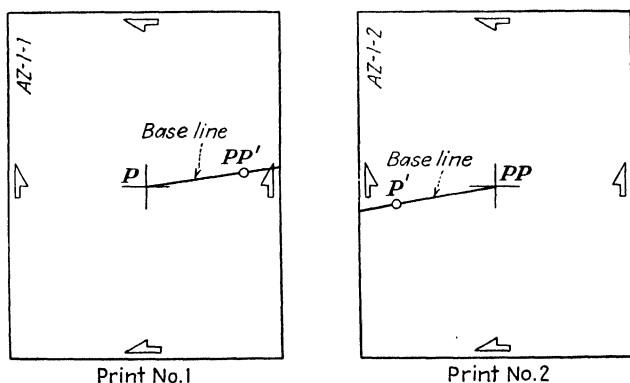

FIG. 138.—Transferring principal points and constructing base lines.

*Flight Line.*—Connect these two points with a very fine line on each photograph, beginning with the principal point and extending through the transferred principal point to the edge of each photograph. This line is called the *flight line*, and the distance between the two points the *stereoscopic base*. The flight line can best be drawn by using a pin and indenting the emulsion.

NOTE: The accuracy of the elevations obtained by the contour finder depends in a large measure upon the accuracy with which the flight line and stereoscopic base have been established.

*Vertical Control.*—Identify, circle, and give the elevations of all known bench marks on both prints (preferably in red ink).

*Secondary Control.*—Locate and circle all secondary control on both prints (preferably in green ink).

*Primary Control.*—Identify all primary control (if any) on both prints (preferably in yellow ink).

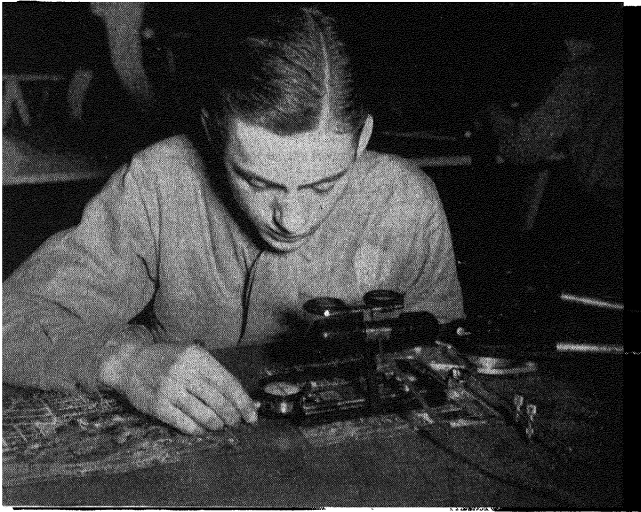

FIG. 139.—Setting up the contour finder.

**Adjustment of Prints to the Instrument.**—The problem of adjusting the prints to the instrument reduces itself to two parts: (1) setting up the left print so that the flight lines and the two parallax dots coincide; (2) setting up the right print in alignment with the left print and also the instrument. There is more than one method of accomplishing this. In the following procedure, various methods will be discussed for each part. The first method in each case will be considered the most exact and the best.

*Setting Up the Left Print.* METHOD I. 1. Center the two gauges, making sure both parallax dots are parallel to the base of the stereoscope. Index the Y axis dial to read zero. The X axis dial should be run back until it stops turning, then turned up approximately three or four full revolutions. The length of the base measurement on the prints should help us determine the amount of X movement

to leave on the dial. With 9 by 9 photographs, it is sometimes best to set the dial up only two full turns so that full stereoscopic coverage of the model can be obtained.

2. Place the prepared left print under the assembled contour finder so that the left dot is exactly on the principal point of the left print.

NOTE: In aligning the left dot over the principal point of the left print, close the right eye, and look through the stereoscope with the left eye.

3. Without moving the principal point or the instrument, rotate the print until the dot coincides with the flight line.

NOTE: While making this alignment, close the left eye and look through the stereoscope with the right eye.

4. Tape down the left print along the left edge, but be certain that both dots are on the flight line.

METHOD II. 1. Center the  $X$  and  $Y$  movements as in Method I, step 1.

2. Place the left print under the instrument so that the flight line is approximately parallel to a line through the parallax dots.

3. Tape down the left print.

4. Loosen the alignment mechanism head, and swing the instrument until the two dots coincide with the flight line.

5. Tighten the alignment mechanism head.

6. Make the alignment more accurate by using the  $Y$  adjustment of the right dot.

NOTE: The setting up of the left print precedes the setting up of the right print.

*Setting Up the Right Print.* METHOD I. 1. Place the right print on top of the left print and under the instrument.

2. With the left dot on the principal point of the left print, slide the right print around until the principal point of the left print, as it appears on the right print, is under the right dot.

3. Hold both prints tightly and slide the instrument over until the left dot is over the principal point of the left print. This point appears on the right print.

4. Without moving the instrument, rotate the right print around the left dot until the flight line coincides with the right dot.

5. Tape down the right print.

6. Check the setup. (a) Look at the two prints through the stereoscope to determine whether a spatial model exists. (b) Place the left dot on several different points on the flight line. At each

point, the right dot also should be on the right flight line. (c) Flip the prints so that the left print is on top of the right print, and see if the flight lines coincide.

METHOD II. 1. Same as in Method I.

2. Same as in Method I.

3. Lift the right parallax glass from the print and drive a pin through the principal point of the left photograph, as it appears on the right photograph.

4. Rotate the right print around the pin, until the flight line on the right print coincides with the flight line on the left print.

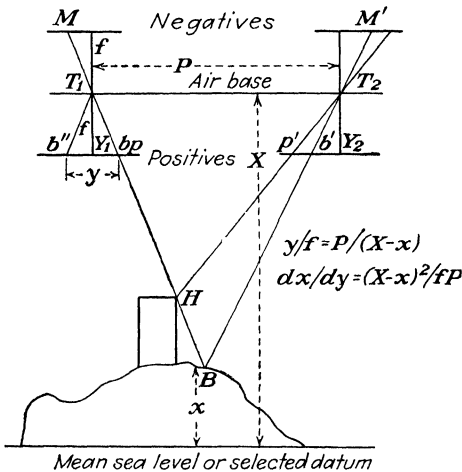

FIG. 140.—Explanation of parallax.

5. Tape down the right print.

6. Check as in Method I.

METHOD III. 1. Measure with a rule the distance between the two parallax dots on the instrument.

2. Place the rule along the flight line of the left print, and from the principal point measure a distance equal to the distance between the two parallax dots.

3. Slide the right print under the rule until the principal point of the left print, as it appears on the right print, is at a distance equal to the distance between the two parallax dots, as measured from the principal point of the left print along the flight line of the left print.

4. Line up the right flight line with the left flight line.

5. Tape down the right print.

6. Check as in Method I.

**NOTE:** These methods described in setting up the second print should be considered as a relative orientation and need changing if there is any error inherent in the spatial model.

**The Parallax Factor.**—In order to determine the elevation of different objects and to know where to set the dial hand on the *X* gauge for drawing contours of a given interval, we must compute the parallax factor for each stereo-pair of photographs. This factor is affected by several things: (1) by flight altitude, (2) by the height of the datum plane to which the altimeter is set, (3) by base measurements, (4) by the focal length of the lens.

*Computing the Parallax Factor.*—1. Obtain the altitude in feet at which the pictures were taken. The altitude may be known or it may be calculated from the following formula:

$$S = \frac{F}{H}$$

where *S* = scale of the print.

*F* = focal length of camera in inches.

*H* = altitude of plane in the same units as the denominator of the scale fractions.

The following examples illustrate the above formula:

*Example 1:*

$$\begin{aligned} \text{Scale 1 in.} &= 400 \text{ ft.} \\ \text{Focal length} &= 10 \text{ in.} \\ \frac{1}{400} &= \frac{10}{H} \\ H &= 4,000 \text{ ft.} \end{aligned}$$

*Example 2:*

$$\begin{aligned} \text{Scale} &= 1:5,000 \\ \text{Focal length} &= 10 \text{ in.} \\ \frac{1}{5,000} &= \frac{10}{H} \\ H &= 50,000 \text{ in.} \end{aligned}$$

In this case, since the scale is a representative fraction, the altitude is in inches. Therefore

$$H = \frac{50,000}{12} = 4,167 \text{ ft.}$$

2. Calculate the ground distance of the stereoscopic base in feet (distance between the print centers on the ground).

$$S = \frac{PD}{GD}$$

where  $S$  = scale.

$PD$  = print distance.

$GD$  = ground distance.

3. Calculate the parallax factor by means of this equation:

$$\frac{dx}{dy} = \frac{(X - x)^2}{fp} \quad \text{or} \quad dx = \frac{(X - x)^2}{fp} dy$$

where  $dx$  = feet of elevation per millimeter of parallax.

$dy$  = millimeters of parallax per foot of elevation.

$X$  = altitude of airplane in feet.

$x$  = height of known datum plane in feet.

$f$  = focal length in millimeters.

$p$  = ground distance of the stereoscopic base in feet.

If  $x$  is zero, the parallax equation can be reduced to

$$\frac{dx}{dy} = \frac{0.03937X}{PD} \quad \text{or} \quad dx = \frac{0.03937X}{PD} dy$$

where  $PD$  = print distance of the stereoscopic base in inches.

4. The photogrammetric computer can also be used for computing both the scale and the parallax equation. In order to find the elevation of a point in feet, multiply the parallax factor by the dial reading in millimeters. In order to determine what dial setting to make for drawing contours, divide the parallax factor into the contour interval desired.

**Determining Differences in Elevation.**—Differences in elevation are measured by differences in parallax as measured by the  $X$  axis dial. When the spatial model is viewed through the contour finder, the two parallax dots will be seen. In order to measure the elevation, it is necessary to have the two dots merged into one so that they appear to be on the ground. Care must be taken to keep the eyes focused on the ground of the spatial model and not on the dots. If the dots are seen as one dot, they may appear to be floating in the air. By turning the  $X$  axis dial in a minus direction, the floating dot will seem to drop to the ground and then separate. Avoid learning to operate the instrument while the dots are separated, for they are intended to be used as a "floating dot." If they are used so, greater accuracy can be accomplished when determining an elevation or drawing a contour line.

In order to bring the dots together before using the instrument, the following steps can be taken:

1. Close the right eye and observe where the left dot is in relation to the print detail.

2. Hold the instrument rigid; and, by closing the left eye, make the right dot intersect the same detail as the left dot, by moving it in or out with the  $X$  dial actuator.

3. Remove the  $y$  difference (if any) by the  $Y$  dial gauge.

4. When both dots intersect the same detail, the dot is nearly on the ground and will appear merged into one when viewed by the stereoscope.

5. In order to determine the exact setting to make on the  $X$  dial gauge for a point of elevation, the "floating dot" should be raised and lowered to the ground in the spatial model several times and an average taken of all the readings.

6. Compute the elevation by the parallax factor and index by turning the face of the  $X$  axis dial to correspond to that reading while the dot is on the ground. This is called *indexing on a known elevation*.

7. After the indexing has been made, the instrument can be moved around over the model and other readings made by following the above steps.

**Application of the Correction Graph.**—Because of errors that may be found in any photograph, corrections have to be made on the

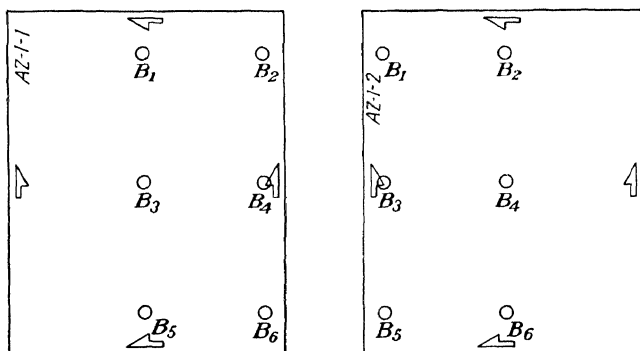

FIG. 141.—Appropriate locations for establishing elevations on two overlapping prints.

parallax measurement in order to get the true contour elevation over the prints. These errors are due to tip, tilt, or distortion. If there are enough points (four or more) properly distributed over the stereoscopic model, whose elevations are known, these errors can be corrected by means of a correction graph (see Fig. 142). First, everything must be done to eliminate as much of that error as possible. If an elevation is known at the top and bottom of the model, the *tilt* can be eliminated by swinging the right print from



its true flight line until the correct parallax reading is created at both points.

*Eliminating Tilt in the Stereoscopic Model.* 1. Compute the following factors:

$$dx = \frac{(X - x)^2}{fp} \quad \text{and} \quad dy = \frac{1}{dx}$$

2. Determine the correct readings for a top and a lower elevation as at  $B_1$  and  $B_5$  in Fig. 141.

3. Move the contour finder over the lower elevation  $B_5$ , and set the floating dot on the ground.

4. Index the  $X$  dial gauge so that it reads correctly at that elevation.

5. Turn the  $X$  dial gauge hand by the  $X$  gauge actuator until it reads correctly at the upper elevation  $B_1$ , and move the contour finder until the dots fall over the detail at that elevation.

6. Stick a scribe or pin through the lower elevation point  $B_5$  into the mount, and unfasten the tape of the right print.

7. While holding the print in position at the lower elevation  $B_5$ , rotate the print until the floating dot of the contour finder rests on the ground at the upper elevation  $B_1$ .

8. Retape the print at this position.

9. Check the readings of the two elevations used by reindexing on one; and, if they do not read correctly within 0.05 mm., repeat the operation.

NOTE: To make a topographic map accurately, consideration should be given to locating the elevational points correctly so that they appear in the proper place on every stereoscopic pair. This is necessary in order to determine the error existing in the model.

*Eliminating Tip and Distortion in a Model.* 1. Check to see if all elevations are located on the prints. Four stations are necessary and should be located near the corners of the model.

2. Compute the following factors: (a) The correct scale of each photograph in the model, and take the average. Use horizontal distances; or if radial line control has been made, take the average. (b) The correct altitude of the plane from the average scale of the photographs. (c) The focal length of the camera to millimeters. (d) The  $dx$  factor by using the corrected components. (e) The  $dy$  factor as equal to  $1/dx$ . (f) The average datum. Add all known elevations and divide by the number. Make this elevation equal to the closest contour interval.

3. Make up a graph computation sheet.

4. Fill in the first four columns of the graph sheet from the information given. (a) Column (1) is the identification of the station. (b) Column (2) is the given elevation of that point. (c) Column (3) is the difference between the elevation of the station and the datum plane. This may be plus or minus. (d) Column (4)

Project <u>S. E. Lansing</u>				Name <u>John Doe</u>			
Photo Nos. <u>AO-1-74, 75</u>				Date <u>4/26/43</u>			
Photo Scale <u>1:4800</u>				Time <u>7 1/2 hrs.</u>			
Focal Length <u>8.25" or 209.55 m.m.</u>							
Altitude of Plane <u>3300 ft.</u>							
Stereo Base <u>2.27 inches</u>							
Average Datum <u>840 ft.</u>							
dx <u>.572</u>							
dy <u>.017</u>							

Interval	Chart
810	2.49
820	2.66
830	2.83
840	3.00
850	3.17
860	3.34
870	3.51
880	3.68

Station	Elevation	$\pm \Delta h$	dy	Parallax Reading	Datum Plane + Parallax Reading	Actual Reading on Micrometer	Correction
AV. DATUM	840	0	.017	0	3.00	3.00	0
B <sub>1</sub>	857.86	17.86	.017	.3036	3.30	3.25	-.05
B <sub>2</sub>	852.09	12.09	.017	.2055	3.21	3.06	-.15
B <sub>3</sub>	840.20	.20	.017	.0034	3.00	3.00	0
B <sub>4</sub>	834.87	-5.13	.017	-.0872	2.91	2.99	+.08
B <sub>5</sub>	862.90	22.90	.017	.3893	3.39	3.39	0
(1)	(2)	(3)	(4)	(5)	(6)	(7)	(8)

FORM 13.—A graph computation sheet.

is the *dy* factor computed in step 2. It will be the same for the entire print.

5. Compute the parallax reading for column (5) by multiplying column (3) by column (4).

6. Compute column (6). Assume some reading for the datum plane (say 2.00 or 3.00 mm.) and add or subtract column (5) to obtain column (6). If  $\Delta h$  is minus, subtract; if it is plus, add.

7. Set the instrument over a known elevation (preferably one of the two used for eliminating tilt) with the floating dot on the ground,



FIG. 142.—A stereo-pair of photographs properly aligned

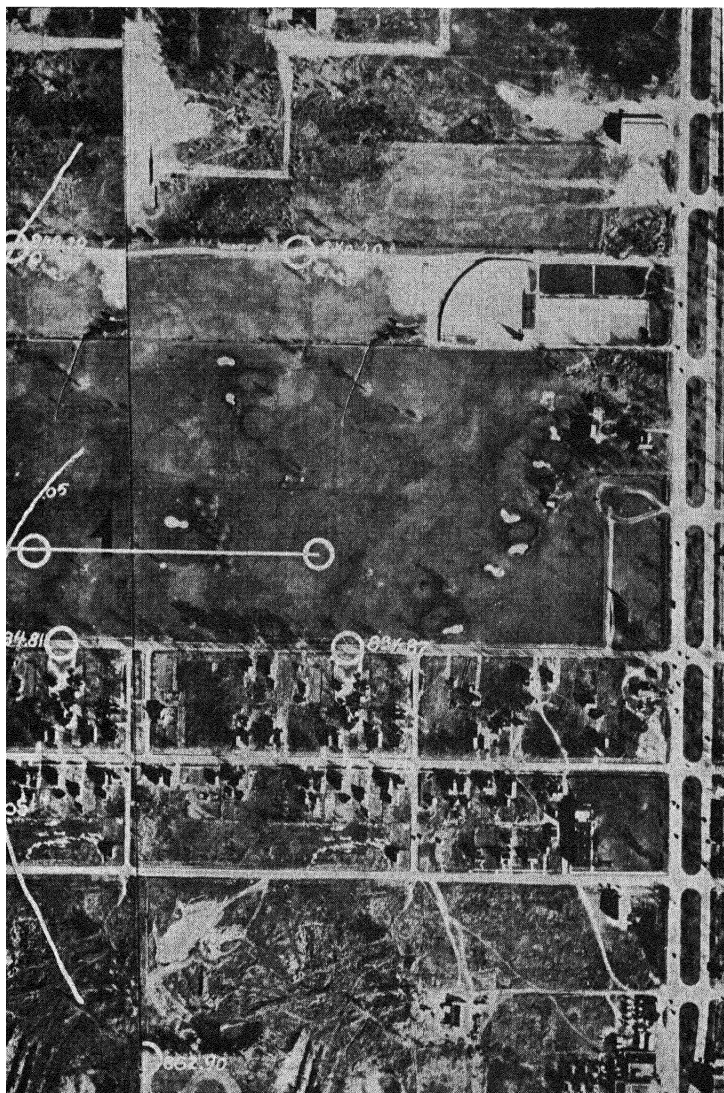

with correction graph lines drawn on one of the prints.

and index the *X* dial gauge to correspond to the reading given in column (6).

8. With the index set on this known elevation, move to other elevations, and set the floating dot on the ground by the *X* gauge actuator. Make the reading on the *X* axis gauge and enter in column (7). Make sure no mistake has been made as to whether the gauge hand moved in a plus or a minus direction.

9. Subtract column (6) from column (7) to get column (8). This is the correction to make.

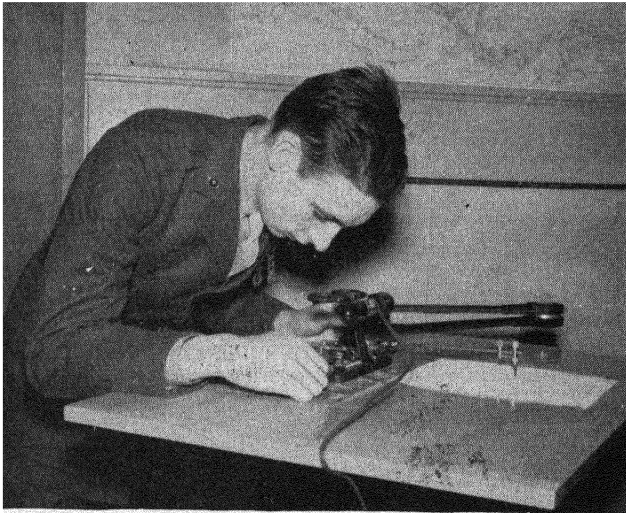

FIG. 143.—A contour finder set up on a plane table.

10. Record the value in column (8), on the left print, by its station.

11. Interpolate for 5-mm. divisions between each station, and draw curved lines connecting points that have the same correction value, whether plus or minus (see Fig. 142). This interpolation is done in the same way that contour lines are interpolated in surveying. A red pencil is most suitable for drawing the graph lines.

12. Trace in the contour line with the instrument indexed on a known elevation located on a zero graph line and change the *X* dial gauge a plus 0.05 mm. when crossing a graph line in a plus direction; and a minus 0.05 mm. when crossing a graph line in a minus direction. This will correct for the error over the entire model, and the contours will be drawn in their proper positions.

13. After contours have been completed for one model, they can be extended into other sketches and carried on for the entire project.

Secondary control should also be identified on each topographic sketch so that each sketch can be properly oriented to the base sheet.

**Finding the Elevation of an Unknown Point.**—To determine the exact elevations of points throughout a stereoscopic model, we need the construction of graph lines on the photographs so that corrections can be made. For determining the heights of single objects this is not necessary.

1. Put the left dot directly on the point of known elevation.
2. Turn the actuator of the *X* axis dial until the dots seem to merge and are resting on the ground.
3. Index the *X* axis dial by turning the face until the zero is under the hands of the dial.
4. Move the instrument until the left dot is on the unknown elevation of the left print.
5. Turn the actuator of the *X* axis dial until the two dots merge and are resting on the ground.
6. Take the reading on the dial, and add or subtract the graph difference, if graph lines occur between the two elevations.
7. Repeat steps 1 to 6 several times until a consistent reading is obtained.
8. To calculate the elevation, multiply the parallax factor by the dial reading, and add to the elevation of the known point, if the unknown is higher than the known point; if it is lower than the known point, subtract.

**The Photogrammetric Computer.**—A special feature prepared for the contour finder is the handy slide-rule computer (Fig. 144), with which it is possible to solve parallax and scale problems easily and quickly. On the outside of the holder enclosing the computer are the instructions for its use.

**Precautions.**—The following precautions should be taken when a large number of prints are being used:

1. Locate all control, both horizontal and vertical, on all prints.
2. Label the tracing paper as model numbers, such as model 1-79, 80.
3. Locate both horizontal and vertical control on the tracing paper. Vertical control is used to check work while drawing contours. Horizontal control enables the compiler to orient the sketch properly to the base sheet.
4. Transfer overlapping control points and topographic detail onto adjoining sketches for the purpose of making the detail match from one model to another.
5. Every print in a line of flight, except the first and last, is to be used in two different models.

6. If the detail is drawn from models that are consecutive in the line of flight, a large strip of tracing paper can be used and the topographic detail carried across for the entire flight.

### HOW TO OPERATE THE MULTIPLEX AEROPROJECTOR

The multiplex aeroprojector is an instrument used for making topographic maps by reprojection of several overlapping aerial

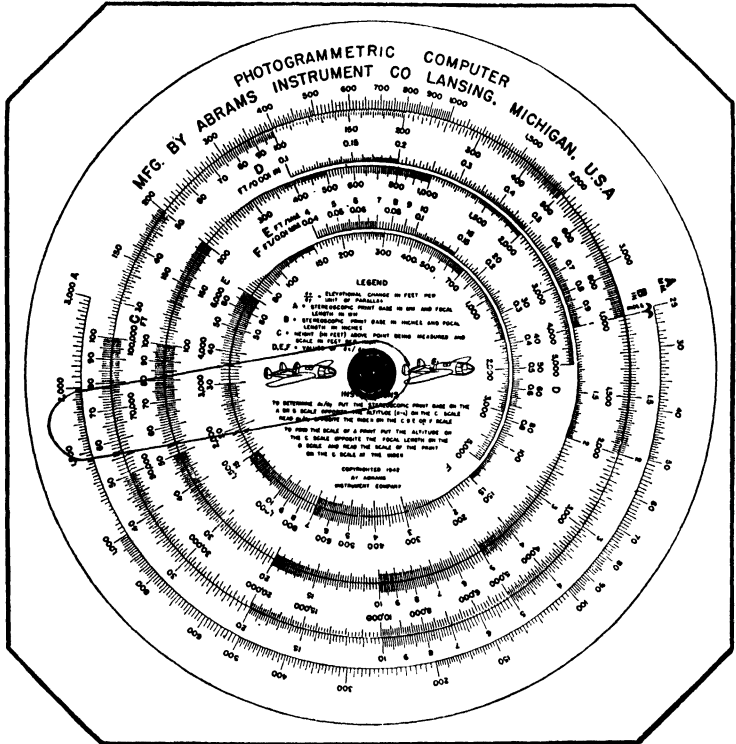

FIG. 144A.—The photogrammetric computer.

photographs. It reverses the operation of the taking camera to form a spatial model true in all respects to the earth's surface.

**Principle.**—The principle of the multiplex aeroprojector has been utilized for a long time in anaglyphs and three-dimensional movies by the dichromatic color process of projection. When two stereoscopic images are projected to the same screen through two different colors of green and red without any parallax involved, they appear as a conglomeration of colors until viewed through a pair of glasses

that has lenses of different colors, one green, one red. The image projected by the red filter should be viewed through the red-colored lens and the image projected by the green filter should be viewed through the green lens. This filters the images, and they appear as black and white reproductions producing a distinct spatial model.

**History.**—The dichromatic process of seeing stereoscopically has been known since 1858, but its utilization in the making of maps

## INSTRUCTION FOR USING ABRAMS PHOTOGRAMMETRIC COMPUTER

The Abrams Photogrammetric Computer has been especially designed to solve parallax equations required in aerial photographic surveying and mapping.

A and B scales represent the following in millimeters and inches: Focal length of camera lens, distance between print centers, and the two scales together provide the conversion table for converting millimeters to inches. Also B scale is used to convert parallax measurements to vertical elevation.

C scale in feet represents: Scale of print in feet per inch and altitude of airplane above the ground in feet. D, E and F scales represent: Feet per .001 of an inch, feet per mm, and feet per .01 mm, and are used for converting parallax measurements to feet of difference of elevation in feet. B, C and D scales are also used for multiplication and division.

To determine print scale, divide the height of camera above ground by focal length of the lens.

Using the Computer put altitude on the C scale opposite focal length on the B scale and read scale of print on C scale at index.

To determine altitude, multiply focal length by scale of print in feet per inch.

Using the Computer, put desired print scale on the C scale opposite the index line and read the altitude on the B scale opposite the focal length of the lens on the A or B scale.

To determine focal length of camera lens, divide altitude above ground by scale of the print.

Using the Computer, put scale of print on the C scale opposite index line and read focal length of lens on the A or B scale opposite altitude on the C scale.

To determine differences in elevation as represented by the parallax equation  $\frac{dx}{dy} = \frac{(X-x)^2}{fp}$  divide elevation of airplane above ground, squared, by focal length of lens, times the distance between print centers, times scale of print.

Using the Computer, put stereoscopic print base on the A or B scale opposite altitude of airplane on the C scale. Read differences in elevation per unit of measurement opposite index on the C, D, E or F scales, depending upon the unit of measurement used.

To determine the total elevational change, multiply the amount of parallax measured by feet per unit of parallax measurement.

Using the Computer, swing the cursor until hair line is over the number of units of parallax measured (read from Dial Gauge) on the B scale and read the total elevation represented on the D, E or F scale.

COPYRIGHTED 1942 BY  
**ABRAMS INSTRUMENT COMPANY**  
Lansing, Michigan, U. S. A.

FIG. 144B.

was first suggested by Theodor Scheimflug, an Austro-Hungarian officer, during the First World War. However, it has been said that two Canadian boys conceived the idea of the multiplex aeropjector, and it was later perfected by the Germans. From the time it was patented, and before the Second World War, the Bausch & Lomb Optical Company, Rochester, N.Y., and the Zeiss-Aerograph, Jena, Germany, were the sole manufacturers.

**Purpose.**—The purpose of the multiplex aeropjector is to reproject overlapping images made by an aerial camera to a workable



spatial model so that all points on the ground are true to some desired scale. In the process, all errors inherent in the photograph caused by tip, tilt, and difference in scale must be removed. The projectors must be mounted so that a total of six different adjustments can be made to eliminate all these errors.

For several years the multiplex aeropictor has been through tests and trials in the experimental laboratories at Wright Field and has proved a very efficient and valuable instrument in topographic mapping.

Since war was declared, the multiplex has become very much in demand, and the Army Air Forces are using it in conjunction with



FIG. 145.—Tracing detail onto a base map from a topographic sketch.

the stereocomparagraph and Abrams contour finder. The instrument is mobile enough to be practical near the fighting line; but, because of the insufficient number procurable, they are assembled quite far behind the lines and used chiefly for picking points of elevation. The negatives taken near or over enemy territory are sent back to a multiplex department for the spotting of numerous vertical control points. Then the prints are sent to the different mapping branches for contouring purposes where skilled operators are employed in making the topographic maps. They use the Abrams contour finder, which is built for mobility and easy operation, *i.e.*, this type of application.

**Accuracy.**—All parts of the multiplex have been handmade and finely tooled to such a degree of accuracy that they are interchange-

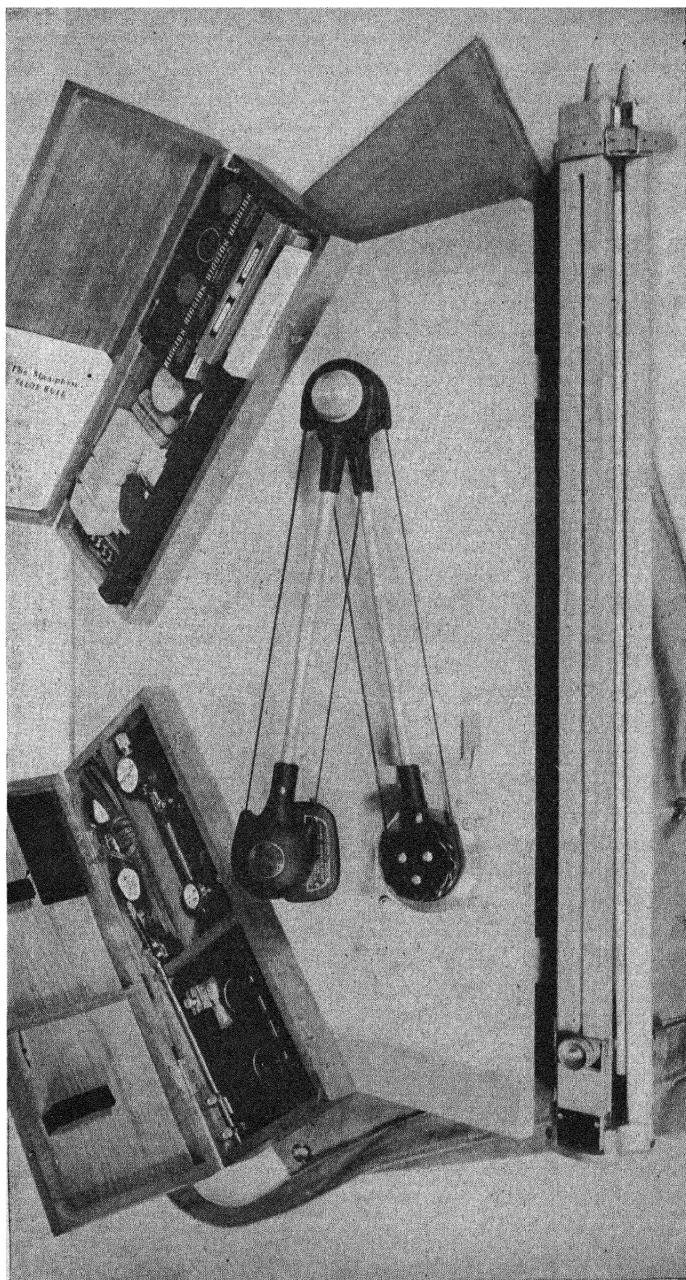

FIG. 146.—A complete Marine Corps kit, comprising a plane table, contour finder, and drafting supplies.

able. There are some instruments that are more accurate than the multiplex, such as the stereoplanigraph and aerocartograph, but they are so bulky and so delicately constructed that they require extremely highly skilled operators; whereas a multiplex operator can be trained to be efficient within 6 months. The multiplex loses some of its accuracy because the negatives are reduced three times when the diapositives are made and then enlarged eight times when

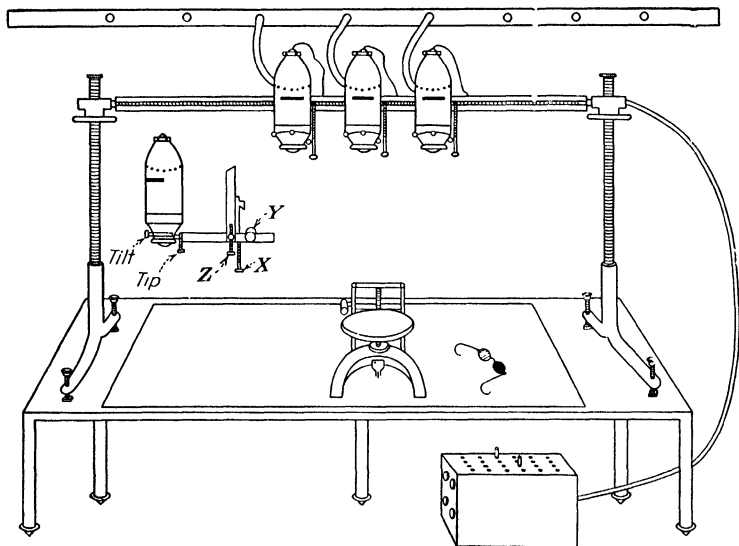

FIG. 147.—The multiplex aeroprinter.

reproduced to a workable scale. This makes a net enlargement of 2.4 times the size of the negative, which causes much detail to become obscure and makes elevational points hard to determine.

TABLE V.—APPROXIMATE ACCURACIES OF STEREOPLOTTING INSTRUMENTS

Name of instrument	Horizontal accuracy	Contour interval accuracy
Stereocomparagraphs and Abrams contour finder	1:500 with mechanical triangulation	1/350 of flight altitude
Multiplex aeroprinter.....	1:500	1/500 of flight altitude
Aerocartograph.....	1:500	1/600 of flight altitude
Stereoplanigraph.....	1:1,000	1/1,200 of flight altitude

One of the reasons for employing shorter focal length cameras when taking photographs that are to be made into topographic maps is the increase in the angle of parallax, which increases the accuracy of the plotting instrument.

Multiplex plotting accuracy depends upon:

1. Plotted accuracy and amount of horizontal control.
2. Accuracy and amount of vertical control.
3. The scale of the photographs.
4. The flight altitude.
5. The quality of the diapositives.

Negatives used for making the diapositives to be used in the multiplex must be of the finest quality. Distortions caused by the taking camera or the improper drying of film result in parallax distortions in the model, which cannot be removed.

The diapositives are reductions of less than one-third of the negative size made on glass plates in positive form. They are made with a reduction printer corresponding to the focal length of the camera used. The negative is oriented in the printer by the fiducial marks, and a small cross is printed onto the diapositives to represent the principal point of the negative.

**Description of the Multiplex Aeroprojector.**—The *table* that the multiplex is mounted on must be rigid, level, smooth, and with correct dimensions. It is usually constructed of aluminum, which is reinforced and mounted on five adjustable legs. The top is planed to a perfect level surface and adjusted to a flat plane by the adjusting screws on the legs until no part varies over 0.01 in. from absolute level. Such a table should be at least 80 in. in length and 36 in. wide. It is necessary that it be at such a height as to permit the operator to reach all adjustable parts of the instrument while sitting. A chair with easy-rolling casters is very convenient in making these adjustments.

The *bar* is the framework of the multiplex. It is a long solid steel bar running nearly the length of the table mounted on two inverted Y ( $\Lambda$ ) shaped legs. The legs have two screw adjustments that can either raise and lower the bar or tilt it. On the face of the bar is a scale graduated into millimeters, permitting the projectors to be moved along its entire length to any given distance.

The *projectors* are the little enlargers that reproduce the images. They are about 8 in. in length and very delicately constructed with a fixed focus corresponding to the focal length of the taking camera. The diapositive is placed inside the barrel on a focal-plane glass and clamped down by four small spring clips. The focal plane has a small dot located exactly in the center. All projectors are of equal

size, and all parts are interchangeable. They hang onto the bar and have six different adjustable motions. In the head of each is a small bulb that can be adjusted to produce even illumination of the image. Slots are made in the lamp house to permit the insertion of the necessary color filter.

A cooling unit must be attached to each projector of a multiplex to overcome the heat produced by the bulbs. The lamp house is so constructed that a hose can be attached and connected to an electric vacuum or blower. Small holes around the outside of the barrel on each projector allow the proper circulation of air to keep the chamber cool.

The transformer controls the light necessary to produce an even illumination. It has four rheostats so that as many as four projectors can be illuminated at one time. This enables the operator to turn on two models at a time, and the process of horizontalizing a strip therefore becomes much more simplified. The tracing table is the most used part of the instrument. It has a small round adjustable top mounted on a horseshoe-shaped base. It is of such a size that it can easily be pushed anywhere over the table by the slightest pressure of the hands. Attached to the table top is a small vernier graduated into millimeters to indicate the change of elevation made by the floating dot. The floating dot is a very small pin point of light produced by a small bulb in the center of the table top. Directly under this pin point of light is a pencil point that can be raised or lowered to the drawing sheet.

*Filters and Glasses.*—Red and green filters are placed alternately in the projectors to produce the dichromatic image. The glasses likewise have red and green lenses. They are made reversible so that the operator can interchange the color of the glasses to correspond to the color produced by the projector rather than change the filters and possibly disturb the clearness of the model.

**Operation of the Multiplex Aeroprojector.** *Preparation.*—Plan the length of the strip to be used so that there is sufficient horizontal and vertical control on each end to permit a proper setup. Horizontal control is necessary on each end of the strip for proper scaling. At least two vertical control points are necessary on the first and last model in order to level the strip properly. From 8 to 10 models can be set up on the bar at one time. This plan is made and a progress sheet kept up by the supervisor during the completion of a project.

Prepare the instrument.

1. Select the number of projectors needed.
2. Place the projectors on the bar so that their images will fall on the projection sheet to be used.

3. Level the bar by the tip and tilt bubbles on each end.

4. Remove the lamp house and insert diapositives in a position reversed to the flight with the emulsion side up. Tap lightly and fasten down firmly at each corner by small retaining clips.

5. Level up the projector by placing a small flat level bubble on the diapositives and adjusting by tip and tilt screws.

6. Even up the projectors in an *X*, *Y*, and *Z* motion until they divide their respective scales.

7. Turn on the lights of each projector, and adjust the bulbs until they produce an even illumination.

*Orientation.*—There are three classified orientations to be made in setting up a flight strip on a multiplex. They are necessary in order to orient each stereoscopic model correctly to its proper scale and relation to the ground, and they should be done in a sequence as listed:

1. Interior orientation.
2. Relative orientation.
3. Absolute orientation.

*Interior orientation* is the proper centering of the diapositive on the focal-plane glass. This is done by registering the collimating (+) center of the diapositive to the principal point (or dot) on the focal-plane glass. To accomplish this, shift the diapositives while the light is turned on by means of the two eccentric block adjustments operated from the outside of the barrel. This fixes the position of the diapositives in their correct *X* and *Y* coordinates with respect to the projector lens. This is done in all projectors before any other operation should be considered.

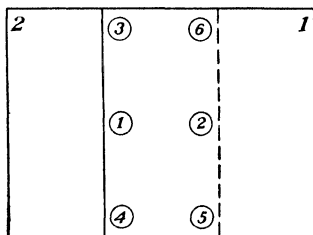

FIG. 148.—Image-point locations for clearing the model.

*Relative orientation* follows interior orientation and is the removal of all parallax due to any scale changes or improper orientation of one photograph to another. It is expressed as *clearing the model*. This is done with the filters inserted in the projectors.

Six operations are necessary in clearing a model and should be taken in the proper sequence if the operation is to be carried out satisfactorily. Figure 148 simplifies the explanation of this operation. Image points for making relative orientation are located as follows:

1. *X Movement, or bx Motion.*—By this motion the base length is changed and the correct scale of the model established. This is

done by adjusting the projectors in an *X* direction until the images are coincident when the tracing table is at a medium height.

2. *The Y movement, or by motion* can be performed in two different ways.

a. One projector can be swung until the image is clear at point 1 by using the swing motion screws on the side of the projector, as indicated in Fig. 147. The second projector is then swung until

TABLE VI.—CONVERSION CHART OF ELEVATIONS—NORMAL ANGLE PROJECTORS

Interval, 20 ft.		Scale, 1:20,000			
Elevation	Millimeters	Elevation	Millimeters	Elevation	Millimeters
20	.30	420	6.40	820	12.50
40	.61	440	6.71	840	12.80
60	.91	460	7.01	860	13.11
80	1.22	480	7.32	880	13.41
100	1.52	500	7.62	900	13.72
120	1.83	520	7.92	920	14.02
140	2.13	540	8.23	940	14.33
160	2.44	560	8.53	960	14.63
180	2.74	580	8.84	980	14.94
200	3.05	600	9.14	1,000	15.24
220	3.35	620	9.45	1,020	15.54
240	3.66	640	9.75	1,040	15.85
260	3.96	660	10.06	1,060	16.15
280	4.27	680	10.36	1,080	16.46
300	4.57	700	10.67	1,100	16.76
320	4.88	720	10.97	1,120	17.07
340	5.18	740	11.28	1,140	17.37
360	5.49	760	11.58	1,160	17.68
380	5.79	780	11.89	1,180	17.98
400	6.10	800	12.19	1,200	18.29

clear at point 2. This makes the model clear only across the flight line, and should be done for the first model of any strip so that the flight line is always kept parallel to the bar.

b. The *by* motion can also be removed by moving the projector along the *y* bar, as illustrated in Fig. 147 until the image fuses at point 1. Then point 2 can be cleared by the swing motion screw on projector 2. This must be done for every model except the first.

3. *The Z movement, or bz motion* is the up and down movement of each projector to bring it to the same scale as the overlapping image. This is done by the *Z* motion screw, as illustrated in Fig. 147, and can be checked for clearness at point 3.

4. *The swing motion* of removing the parallax has been explained under the paragraph on *by* motion, but it is a separate movement, because it is the orienting of the flight line of one diapositive to another. Its clearness is checked at either point 1 or point 2, depending on which projector has been swung.

5. *The tilt motion* is made by the tilt motion screw, and the projector is tilted until it passes twice the distance it takes to clear the image at point 4. The parallax is then removed by the *bz* motion. This operation is continued until the model is clear at points 1, 2, 3, and 4.

6. *The tip motion* is made by the tip motion screw. The projector is tipped until the image is clear at 5 and 6. This motion changes the scale and must be rescaled by the *bx* motion.

At any time when there is much parallax in a model due to excessive tilt or crab, it is hard to clear a model. Then this operation must be performed several times, but it should be made each time in the proper sequence as indicated. The operation is continued until the model is clear at all points 1, 2, 3, 4, 5, and 6. The first model is then properly scaled to two known points on the projection sheet and leveled to the known elevation points by the tip and tilt adjustment screws. This eliminates the possibility of running out of screw extension space when the end of the strip is reached. All models throughout the strip are cleared in the same manner and tacked on by moving the projectors in a *bx* direction until an elevational point on the model to be tacked on reads the same as it did in the preceding model.

Table VI indicates how much to raise or lower the tracing table when drawing contours. The elevations must be changed from feet to millimeters, for the vernier located on the tracing table is graduated in millimeters. Before the conversion table is used, the "floating dot" must be indexed on some known bench mark whose elevation has also been changed from feet to millimeters.

*Absolute Orientation.*—This orientation is the absolute location of all points throughout the strip to their true locations on the projection sheet by leveling and horizontalizing the entire strip.

1. Level both models on the end of the strip to known bench marks.

2. Make all models check to the known horizontal points on the projection sheet by use of the *bx* formula.

$$bx \text{ (new)} = \frac{bx \text{ (old)} \times \text{distance on projection sheet}}{\text{distance of models}}$$

or

$$\frac{D}{H} = \frac{\Delta D}{\Delta H}$$



where  $D$  = distance on projection sheet in centimeters.

$H$  = height of projector from the tracing table when indexed on a datum point in centimeters.

$\Delta D$  = difference between old and new distances in millimeters.

$\Delta H$  = change in millimeters to be made on the elevation of the tracing table to determine the amount of change to be made in the  $bx$  motion.

After the new  $bx$  change is determined, all projectors are again tacked together in a plus or minus  $bx$  direction, depending on whether the model image is larger or smaller than the projection sheet. This is repeated until all horizontal points fall on respective points on the projection sheet. On a radial control projection, one model at a time can be scaled. This procedure horizontalizes the strip. Though the strip is roughly level, it permits neither the drawing of contours nor the picking of vertical pass points. As soon as horizontalization is made, the principal point of each projector should be picked and marked on the base sheet.

Before drawing contours or planimetry, each model should be leveled separately and the base sheet oriented until the principal points coincide with those made by the projectors.

**How to Level Each Model.**—When four known elevations are scattered throughout the model we can level by adjusting the screws on the legs of the bar until three points read correctly on the vernier of the tracing table. Check by the fourth known elevation. Models should have three elevations to level properly and should be located in such positions that both tip and tilt can be removed.

If only one or two elevations are known in a model, it is impossible to level it properly unless we have a coast line or meandering stream running across its entirety. Then the model can be made flat in respect to the stream, and the "floating dot" can be indexed on the known elevation for drawing contours.

Picked points, often called *pass points*, can be made after a model is level and extended into other adjacent models. This is necessary when we have not sufficient vertical control. Many such pass points should be picked in every model before another is considered.

To simplify all operations in operating a multiplex, these steps should be memorized and followed in sequence:

1. Level bar with the foot screws and handwheel.
2. Make the  $Z$  and  $Y$  readings the same on all projectors.
3. Ascertain the direction of north, and place all diapositives in their proper projectors.
4. Place the spot bubble on each diapositive, and level with the tip and tilt screws.

5. Make the interior orientation in each projector. Centering of the projector bulbs may be done at the same time.
6. Remove the parallax in the first model, keeping the *Y* readings the same on both projectors.
7. Level the first model.
8. Obtain the base sheet and scale the first model. At this time make sure that the projectors are in proper position to allow the sheet (or sheets) to lie flat on the table.
9. Remove the base sheet. Clear and tack on all additional models.
10. End level the strip, averaging the levels if necessary.
11. Obtain the base sheet (or sheets) and scale the strip.
12. Pick and number all projector centers. If two sheets are stapled together, prick through all points that will appear on the bottom sheet.
13. Level each model separately for drawing contours and planimetry. Make sure all centers fall on their respective positions on the base sheet.
14. Pick numerous points of elevations throughout the model while it is indexed on the nearest known bench mark.

## CHAPTER XII

### TOPOGRAPHIC RELIEF MODELS

**General Considerations.**—The ideal way to represent any small region for study or demonstration is by use of a relief model. Primary in our consideration is the value of such a model to military planning and operations. To the commander or staff planning an attack, a relief model of the terrain that will be encountered will prove to be an immeasurable aid in the plan of strategy.

In the construction of all relief models, the first consideration is the scale to which it will be constructed. Let us investigate briefly the relation between horizontal and vertical scale as it actually is on the surface of the earth. Let us suppose that the highest mountain on the earth is 5 miles. Also, let us suppose that the deepest spot in the ocean is 3 miles. This would mean that the greatest wrinkle in the surface of the earth would be 8 miles. Let us now set up the ratio of the total diameter of the earth (about 8,000 miles) to the deepest wrinkle, which is 8 miles.

From this we see that, if the earth were reduced to a globe 20 in. in diameter, we should have the proportion

$$\begin{aligned}8:8,000::X:20 \\8,000X = 160 \\X = 0.02 \text{ in.}\end{aligned}$$

We should therefore have a 20-in. globe with a maximum deviation, due to relief, from a true spherical surface of 0.02 in.

Since the earth is not a true sphere but an oblate spheroid, there is a small deviation in our 20-in. globe. The polar diameter of the earth is about 26 miles shorter than the equatorial diameter. Again applying our proportion

$$\begin{aligned}26:8,000::X:20 \\8,000X = 520 \\X = 0.065 \text{ in.}\end{aligned}$$

Our 20-in. globe would therefore be 0.065 in. shorter in its polar diameter.

This brings forcibly to our minds how smooth the surface of the sphere really is. It also reminds us that, to show adequately any

area of the earth's surface in a relief model, there must be some exaggeration of the vertical scale.

**Scales.**—If we are considering the construction of a relief model covering an extensive area, such as an entire state, the exaggeration must be much more than that which would be applied to a small area of a limited extent. In some cases, this exaggeration will of necessity be as much as twenty times that of the horizontal scale. This is necessary so that our model will be other than a seemingly flat surface. Care must be exercised in the exaggeration of the vertical scale, however, or we might have a completed model in which a 5-deg. slope would appear very steep, an isolated hill would appear as a pinnacle and a valley as a canyon.

Such a relief model would be of some value but would really be more caricature than a true picture of the area.

In actual use, we find that for scales of 1:600 up to 1:1,200 it is sufficient to exaggerate the vertical scale about 100 per cent, and not more than this for a scale of 1:600. We should then have a horizontal scale of 1 in. = 50 ft. and a vertical scale of 1 in. = 25 ft. This is a large-scale model in many ways and for all military purposes should be large enough. Architecture and landscaping frequently require models of much larger scale, such as 1 in. = 5 ft. or 1 in. = 2 ft. In models of this scale, no exaggeration of the vertical scale is necessary.

From this we may conclude that, in very large scale models, no exaggeration of the vertical scale is necessary. In very small scale models, a large amount of exaggeration is necessary to show the relief. There is no fundamental rule that we can follow that will give us the amount of exaggeration necessary for a given horizontal scale. Rather, it depends on the good judgment of those charged with constructing such a map.

**Materials.**—There are many materials suitable for making good topographic relief models. Chief among these, of course, are modeling clay, molder's sand, papier mâché, and plaster of paris. Practically any material that is at hand can be used by an ingenious builder. Sawdust, glue, and muslin have been used with success. The limit of materials is fixed only by the ingenuity of the person who is making the model. Of course, it is better to have all the modern tools and accessories to work with, but their absence need not hinder anyone in making a model entirely suitable to the problem at hand.

Basically, there are several methods of constructing topographic relief models. These differ only in the manner of vertical control. Any one of the above-mentioned materials may be used in these

methods, although some materials are more suitable to one method than to another.

In all methods, it is necessary to have a topographic map of the area, or a map showing the contours at a definite interval. The map can be of any usable scale, such as 1:63,360, 1:2,000, or even larger. Beautiful models have been made from maps with a scale of 1:4,800 enlarged to 1 in. = 50 ft. for the model.

**Data Conversion from Map to Model.**—Enlargement of contours from the scale of the existing map to the desired scale of the model may be accomplished by several methods. If a photostat machine is available, they are enlarged to the desired scale, and as many copies as are necessary are made. A direct photographic copy enlargement may be used. This is rather slow and expensive. A precision pantograph is very useful for this and possibly offers one of the most precise yet most economical means of making the enlargement. If no other means are at hand, the map may be divided into small squares and another large sheet of paper divided into an equal number of squares, their size being determined by the following proportion:

$$\frac{\text{Map scale}}{\text{Desired scale}} = \frac{\text{map grid dimension}}{\text{desired grid dimension}}$$

Each small square is then treated individually, and the contours are drawn in freehand. Accuracy may be maintained by careful workmanship. This method of enlarging the contours to a desired scale should be understood and practiced by everyone who contemplates doing this type of work. It offers a fast, accurate method of accomplishing this important step with a minimum of equipment. Necessary equipment is reduced to a scale and a pencil.

With the contours of the area now enlarged to the proper scale, we are ready to proceed with the actual construction of our topographic relief model.

**Cardboard Layer Method.**—In the first method, which we may call the cardboard layer method, the relief model is built up of successive layers of cardboard. The desired scale of the model and the vertical scale that will exaggerate the relief to the best advantage are determined. Assume that the horizontal scale desired is 1:600, or 1 in. = 50 ft. The exaggeration of vertical scale most suited to this scale is approximately 2 to 1. This would result in a vertical scale of 1:300, or 1 in. = 25 ft. The selection of the proper thickness of cardboard will depend directly on the contour interval of the map. Let us assume the map to have 2.5-ft. contour intervals. Dividing this into the vertical scale, we find it necessary to have 10 layers of

cardboard for every inch; therefore each cardboard layer should be 0.1 in. thick, representing 2.5-ft. elevations.

The next step is to trace each contour on to a separate sheet of cardboard or to glue a map on each cardboard. If the contour is traced, the complete build-up will need a control so that each successive layer will fall in its proper position in relation to the preceding layer of cardboard. Dowel pins placed in the point of highest elevation may be used. Two pins are used in each high point, and their position is accurately indicated on each successive layer as it is outlined. Holes are punched in the cardboard allowing the dowel



FIG. 149.—Constructing a cardboard layer model.

pins to fit snugly in the indicated positions. Long slim nails, with the heads cut or filed off, make ideal pins when driven into the base in their true position.

The first layer of the model is a solid map of the area with no portion of it cut away. This gives the position of all dowel pins, the area that will be covered by the model, and other necessary information. The next layer of cardboard has only the lowest portions cut away. This cutting may be done on a fine band saw or a jig saw if reasonably thick cardboard is used. It may be done with a very sharp knife or scalpel if the cardboard is thin. Care must be exercised in cutting along the contour lines, for a slight deviation will cause a false representation of the slope. This becomes very important as the slope angle increases, because a slight devia-

tion, coupled with the induced exaggeration, will cause appreciable error in the form of the model.

After the first two layers are down, the procedure is the same for each succeeding layer. Cut out the cardboard on each contour line, and place each in its proper position. This is done until the point of highest elevation is reached in each case. This gives a "step-up" base upon which to complete the model. It should be noted here that the upper edge of each layer represents the contour, for this is the contour line, and the thickness of the cardboard represents the vertical distance up or down to the next contour.

The model is now ready for covering. A good grade of modeling clay can be used most satisfactorily. Foundry molder core sand can also be used.

If sand is used, the cardboard should be given a coating of orange shellac to prevent it from absorbing moisture from the sand. This absorption results in two undesirable occurrences. First, the cardboard absorbs the moisture and swells out of shape. Second, the sand loses its moisture, shrinks slightly, and cracks. The combined result is a model very much out of shape and badly cracked. Its value is practically worthless.

The covering consists of filling the area between the respective contours so that a uniform slope appears from one contour to the next. It is assumed in topography that the slope between two contour lines is uniform. A small spatula or putty knife is useful in covering and smoothing the sand, and an orangewood stick, such as manicurists use, will be of value in working with small detail. No doubt the builder will use his fingers as much as other tools while applying clay or sand to the foundation. The small details of gullies, ditches, and small valleys are all carefully worked in on the covering of the model. This serves a twofold purpose. It is an excellent base upon which to paint, and it prevents the loss of oil or moisture from the model, thus making it stable. It is essential to protect the original if a plaster negative is to be made from which the model can be duplicated. The process of duplication will be covered later.

Painting and finishing the model will depend upon the purpose it is to serve. All models should have stream courses and other water features represented. These are painted blue. Woods are represented by several methods. A dark-green paint may be striped on the model. This method does not give the model a nicely finished appearance, such as that which would result from using small bits of dyed green sponge on short sections of toothpicks, but it has the advantage of leaving the surface of the model unob-

structed. The form of the model is much easier to study if the woods are painted on. All roads and trails should be painted on in a neutral tan or brown color. Names of important points should be placed on the model. A north indication helps anyone not familiar with the area to orient his work.



FIG. 150.—Applying the detail to the model by using an aerial photograph.

**Sandbox Method.**—Another method of constructing a relief model may be called the sandbox method (see Fig. 151). In this particular type of construction, a box of the proper size to accommodate the entire model, with side walls possibly 2 to 3 in. high, is necessary to serve as a base.

This box may be made of light timber, composition board, or three-ply plywood. Plywood is probably the most desirable of the three materials because it is strong and light and nails can be driven into it, without danger of splitting. Most plywoods of this type are made more or less waterproof. This is an advantage because of the high moisture content of the sand used in construction.

The scale of the model must be calculated so that the box may be made of a sufficient size to accommodate the area desired. In this construction, as in the construction of the cardboard layer type, it is necessary to have a topographic map of the area of which we are to make a model. The contours from the topographic map will be enlarged to the desired scale by the method already outlined. These contour lines to the desired scale can now be drawn upon the



board that is to serve as the base of the relief model. The numbers indicating the elevations above datum must be indicated on the proper contour, to avoid confusion in succeeding steps of the construction.

The next step is to secure a sufficient quantity of long slim nails of assorted lengths. Nails of the finishing type used by carpenters in interior trimming serve admirably for this purpose. These nails must range in length from  $\frac{3}{8}$  to 3 or 4 in. The vertical scale

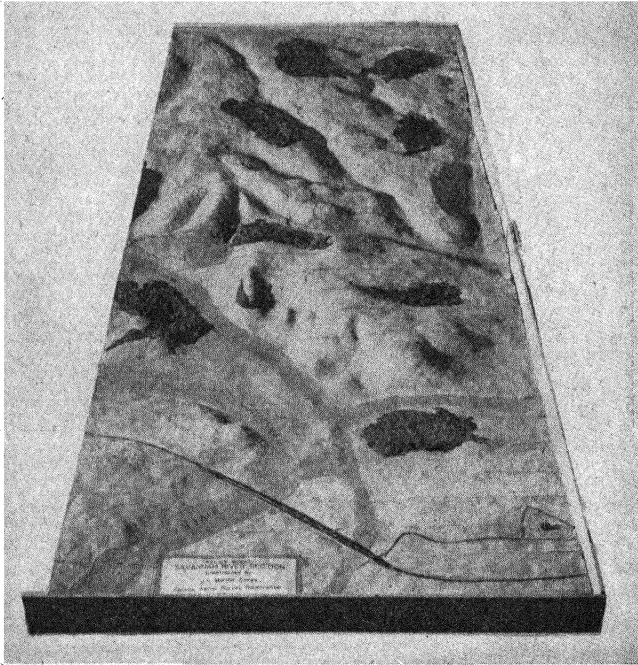

FIG. 151. A sandbox model.

of the model is computed, and the difference in contour interval is reduced to its fractional part of an inch. The nail of the proper length is now driven into the contour line indicating the lowest elevation in our relief model. Nails of this length are driven in along this contour line at all turns and angles in the line. If the line runs straight for any distance, nails should be driven in between the nails on the turns to serve as guides later in the construction.

A word here about the distance to which these nails should be driven might help a novice model builder. Assume that the board serving as the base of the model is some known distance above the

datum plane and just below the low elevation of the area to be modeled. We now figure the height in inches or fractions of an inch that the next higher contour line will assume above the base. The nail is chosen of a length slightly longer than this vertical distance, thus allowing us to drive the nail firmly into the model base and yet have enough of it projecting above the base to indicate a definite elevation. All contour lines of the same elevation are treated in exactly the same way, nails being driven into the base, indicating this elevation wherever it may appear in the relief model.

A small hardwood block, possibly 1 in. square with a hole drilled through its center just large enough to fit over the nail loosely will help considerably in driving the nails. Such a block should be cut to the proper height for the elevation above the base for the particular contour line it is being used on. The block can be placed over the nail after the nail is started in the base, and the nail can be driven down flush with the top of the block. This eliminates all possibility of driving a nail in too far or leaving it projecting too far above the base.

The next higher elevation is treated in exactly the same manner, nails of a proper length being used so that they will project high enough above the base to give the proper indication of elevation. Each successive elevation is treated in the same way. It is necessary to proceed from the lowest elevation to the next higher elevation in all cases so that there will be no interference from nails indicating a higher elevation when the nails in a lower contour are driven in. We have now proceeded from the lower elevation of our model through the successive contour intervals to the highest elevation of the model and have nails of the desired length to indicate contour lines.

We are now ready to proceed with the filling in of the box to form the model. Core molder's sand is the most desirable and adaptable for this purpose. However, any good grade of sand from a beach or any other source, if sifted to eliminate foreign matter such as stones or small pieces of wood, can be used with a large degree of satisfaction.

When the model is large and is not to be moved very much after completion, excelsior, wastepaper, or any other light material may be used as a filler in the thicker parts of the model, with a thin layer of sand added to finish off the top. This will make the model much lighter than if it were made completely of sand. The sand on top of the filler is now packed into the box up to the tops of the various nails. As was mentioned in the description of the previous models, in topography and particularly in modelmaking, the slopes between contours are assumed to be uniform unless some

other indications are given that they are not or that some special feature exists at a particular point. The builder should keep this in mind as he proceeds with filling in the box with sand or other material up to the height of the various nails.

We now have a shallow box with sand of various thicknesses, brought up in the proper height representing the elevation of the terrain of the area being studied.

This type of model map may be finished in the same way that the cardboard model was finished. If duplicates are to be made, a layer of shellac or some other binder may be used to spray over the surface of the model. After this sets, the surface may be painted or treated in any other manner that is desirable for the purpose at hand.

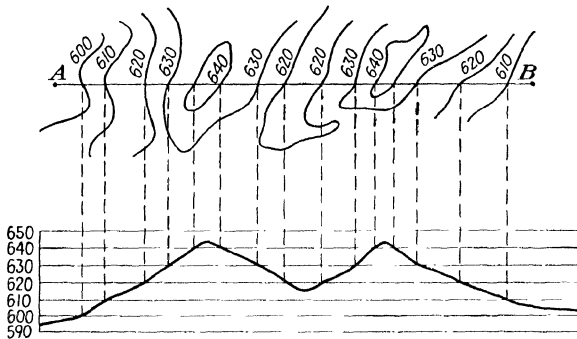

FIG. 152.—Constructing a profile pattern from a plane passed perpendicular through the topographic sketch.

**Profile Method.**—Still another method of building the contour interval is by the profile method. The same procedure is used as in the other methods in determining the scale and enlarging the portion of the topographic map to be used. Then, by drawing parallel lines across the enlarged area about 2 in. apart, we determine the lines at which we are to draw profiles.

To construct a profile like that in Fig. 152, we need a profile of the line *AB*. Assume that a vertical plane is passed through the line *AB*. Rule a piece of paper with lines representing the contour interval desired at the vertical scale of the relief model. In Fig. 152, we are to use a 10-ft. interval. Place the ruled paper parallel to the line *AB*, and drop perpendiculars to the horizontal line on the ruled paper corresponding to the elevation of the contour being considered. Then connect these points with a line, and the result will be a profile of the line *AB*. This procedure must be followed for a profile at least every 2 in. across the model.

Transferring these profiles to a mount of either solid cardboard or light plywood, and cutting out the profile, we are ready to assemble them. It is necessary to make a sandbox of the desired size and then fit the profile strips inside the box in such a way that they can be tacked into place in the correct positions. The intervals between profile strips are then filled with sand or any other available material. The terrain is made to slope uniformly between strips, and the surface is painted. The model is now ready for detail work. A suitable coating on a sand model is made by mixing cement and water to form a very thin paste and brushing it on the surface. When this dries, it forms a hard surface upon which painting or detail work can be carried out.

The finishing of a model is the work of an artist. With the use of aerial photographs of the area and a stereoscope, the detail of the terrain can be duplicated with great accuracy. Great care in the construction of a relief model should be exercised to ensure accurate representation and to show the desired detail without cluttering the model with unimportant detail.

## CHAPTER XIII

### RESTITUTION AND RECTIFICATION OF AERIAL PHOTOGRAPHS

**Definition.**—Restitution is the restoration of all the incorrect positions of points on an aerial photograph to their correct or nearly correct photographic positions on a map by correcting for difference in scale, tip, tilt, and displacement due to relief.

**Need for Rectifying a Vertical Aerial Photograph.**—It is the pride of any map maker to make his map as accurate as possible. Since aerial photography has become so popular in map making, we should consider all errors inherent in such photographs and develop methods to overcome them. It has been proved that very accurate maps can be made from aerial photographs if they are properly restituted.

In making topographic maps, the restitution of points or the rectification of prints can be made by the use of the prints on hand provided that they do not have excessive tip or tilt or great scale changes. Of course much time and labor can be saved if the prints are restituted by the photographic method, in order to trace planimetry and contours. If prints are used that have not been restituted, the inherent errors must be distributed throughout the area by some method of rectification.

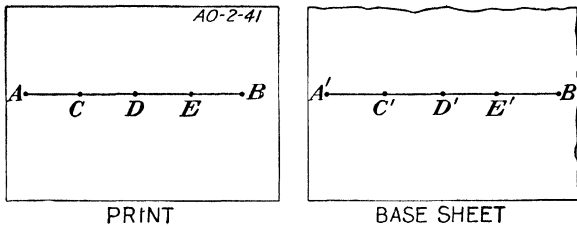

FIG. 153.—Rectifying between two known locations.

**Restitution Method of Locating Unknown Points.** *When Positions of Two Points Are Known.*—1. Locate the known points on the base sheet.

2. Identify these points on the photograph.

3. Draw a straight line between the points on the base sheet and on the photograph.

4. Divide each into equal parts. The points that fall on the base sheet are then identical to those found on the photograph.

*Tracing-paper Method.*—1. Fasten a piece of vellum over the photograph with three or more known points identified.

2. Choose a point near the center of these points and transfer it to the vellum.

3. Draw radial lines from this point through the unknown points.

4. Place the vellum on the base sheet so that the radial lines intersect the known points that have been plotted on the base sheet.

5. Locate, from the vellum, the position where the unknown point falls on the base sheet. This will be the true location of that point.

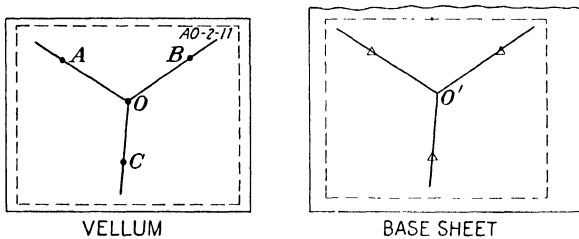

FIG. 154.—Tracing-paper method.

In Fig. 154, points *A*, *B*, and *C* are the known points. Point *O* is the unknown point on the photograph. Point *O'* is the plotted unknown point.

*Radial line control method* (see the section in Chap. XIV on mechanical triangulation).

**How to Rectify Contact Prints.** *Triangular Method.*—1. Connect the three known identified points on the photograph by straight lines.

2. Connect the same points that are plotted on the base sheet by straight lines (the base sheet should be acetate or some transparent material).

3. On both the photograph and the base sheet, bisect the angles of the triangles that are formed. This establishes the location of a new point and divides the larger triangles into six smaller triangles.

4. Place the photograph under the base sheet, distributing the error as much as possible by orienting the print until the similar points nearly coincide.

5. Draw the detail desired while the print is properly oriented under each similar triangle. The more triangles we have, the more decreased the error becomes.

In Fig. 155, points  $A$ ,  $B$ , and  $C$  have known locations. Point  $O$  is a new located point on the photograph. Point  $O'$  is the same point plotted on the base sheet.

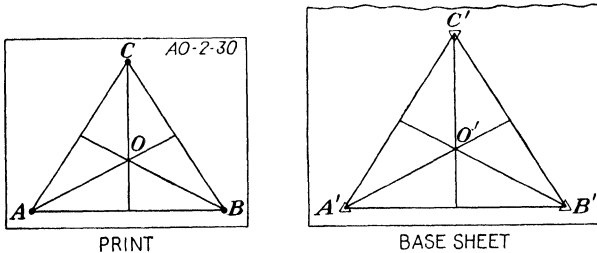

FIG. 155.—Triangular method of rectifying.

*Grid Method.*—This method requires the location of four known points on a photograph.

1. Plot the four known points on the base sheet.
2. Identify them on the photograph.
3. Connect all the points by drawing straight lines on both the photograph and the base sheet. This will form rectangular figures.
4. Divide the opposite sides into equal parts on both photograph and base sheet. This will make many similar rectangles.
5. Place the photograph under the base sheet until the similar figures nearly coincide.
6. Draw the detail desired while the print is oriented. The print must be reoriented to each grid before the planimetry can be drawn.

In Fig. 156 points  $A$ ,  $B$ ,  $C$ , and  $D$  are located known points.

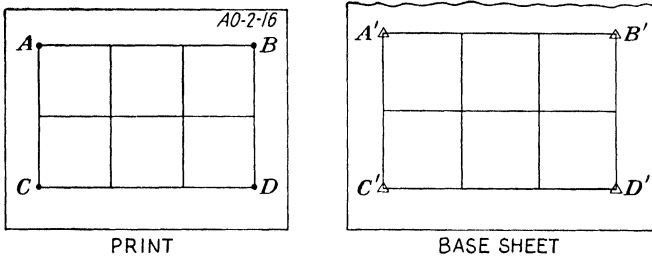

FIG. 156.—Rectangle method of rectifying.

*Radial Control Method* (see the section on mechanical triangulation in Chap. XIV).—This method is a triangular method for rectifying prints. All the necessary points are already made, and all that is necessary to rectify a print is to adjust it to its closest correction under each similar triangle formed. There are at least eight triangles formed for each print by radial line control.

**Photographic Method of Restitution.**—The photographic method involves the process of projecting the negatives to fit certain areas in the survey.

*Description of Restitutorial Projectors.*  
The vertical projector is the most convenient and common type of projector used in restitution. It is comprised of three main assemblies of which each can be adjusted to produce effects desired in correcting for different errors in the photograph.

The *head* is that part of the projector which contains the negative and lamp. It is mounted so that it can be tipped or tilted to increase a greater field of focus during excessive tilt corrections. It can also be lowered or raised to give the scale desired.

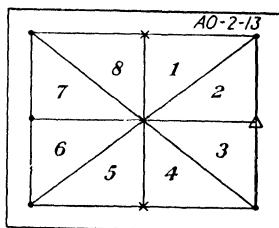

FIG. 157.—Dividing a photograph into several triangles so that rectifications can be made.

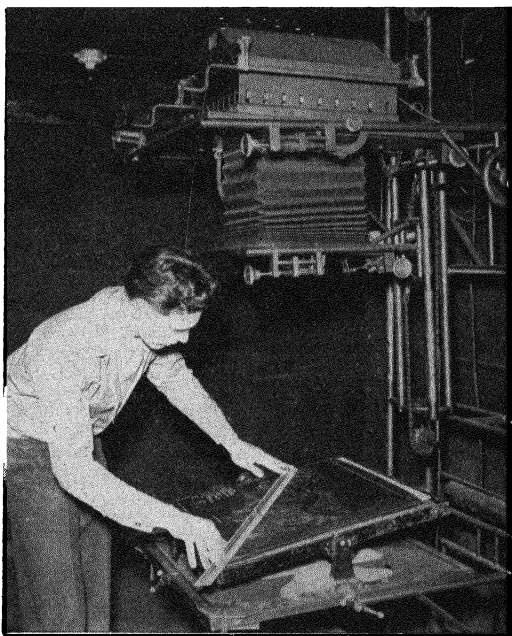

FIG. 158.—A restitutorial projector.

The *lens board* is attached to the bellows and mounted as a separate unit. It holds the lens and can also be tilted and tipped to make the principal point of the photograph fall on the principal point or axis intersection of the easel.



The *easel* is a flat surface board mounted on two bisecting axes in such a manner that their intersection falls directly under the lens or principal point of the print when both are parallel.

The easel can be tilted or tipped to any amount up to 45 deg. provided that the lens has sufficient depth of focus to produce a sharp image over all. After the easel has been tipped or tilted the required amount to eliminate that error, an unexposed sheet of photographic paper is placed on the easel and exposed. The entire area of any photograph can be entirely corrected by this method when there are only errors of tip, tilt, or difference in scale.

The horizontal projector has the same features as the vertical projector except that the work is performed in a horizontal position. This causes difficulty in holding the projection paper firmly in its proper location on the easel.

**Restituting for Difference in Scale.**—If we have two known distances on a print, they can be projected to any other scale desired, provided that it is not beyond the limits of the projector. In this operation, the photographic negative is kept parallel to the easel, and only corrections for scale differences can be made. This method is used extensively by the Agricultural Adjustment Administration, which is interested only in obtaining a mean scale over a large area for making measurements by which to determine the area of fields. It is also used by others to make semicontrolled mosaics and uncontrolled overlays.

**Restitution for Tip, Tilt, and Difference in Scale.**—To make a restituted print corrected for all these errors, we need the position of at least three points. With the distances known between these points, which form a triangle, the projector head can be raised or lowered to a mean scale and the easel can be tipped or tilted until those points correspond to their correct measurements. This method affords a good way to make patches to fit places on a mosaic that are mismatched.

*Pyramiding* is the projection of several patches with different scales of the same area and placed one over the other to correct for an excessive error due to relief displacement.

**Restituting for Radial Line Control.**—This system of restitution corrects for difference in scale, tip, tilt, and relief displacements. It is used when a very precise map is to be made. A radial line control plot has nine or more accurately located geographical positions for each photograph. For each point a ratio factor must be made out. It is found by dividing the distance on the base sheet from the principal point to the plotted point by the same distance on the print. This is done for every point that falls in the

area covered by the photograph, and some graphic method must be set up to show these ratio relationships, in order to determine where the tilt axis occurs. To simplify this method, a ratio computation sheet is made up and attached to each photograph it represents. In mountainous rugged terrain, the ratios will vary greatly, and it is sometimes difficult to determine the tilt axis. Then a mean ratio factor should be considered for projecting the first photograph, and patches should be made by triangular or pyramidal methods to correct for those points that will not fall on their true positions. If necessary, it is possible to make as many as eight such triangular

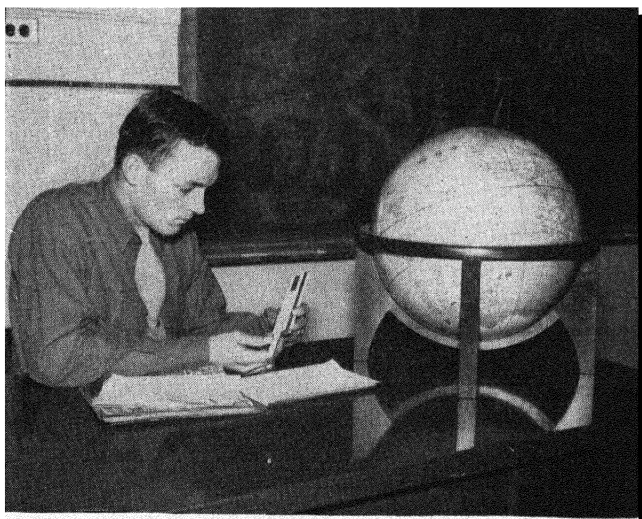

FIG. 159.—Computing ratios by using a slide rule.

patches in order to make all points of a photograph fall in their correct positions.

On all vertical aerial negatives, located at the edge, in the exact center of all sides, are four fiducial points. These points (commonly called *collimation marks*) are used with the following equation in making measurements when restituting the photograph.

$$\frac{PS}{RS} = \frac{PD}{RD}$$

where  $PS$  = print scale.

$PD$  = print distance between fiducial marks.

$RS$  = restituted scale desired.

$RD$  = restituted distance between fiducial marks.

**Scaling a Restituted Projection.**—After the ratio factor and tilt axis have been determined for restituting a negative, some means of speeding up the operation in printing is necessary. This can be done by making an easel template for each camera used in the survey.

*Steps in Constructing a Projection Easel Template:*

1. Select a piece of white cardboard larger than the photograph to be made.
2. Locate the center of the cardboard and erect two perpendiculars.
3. Measure the distance between the fiducial points on the camera.

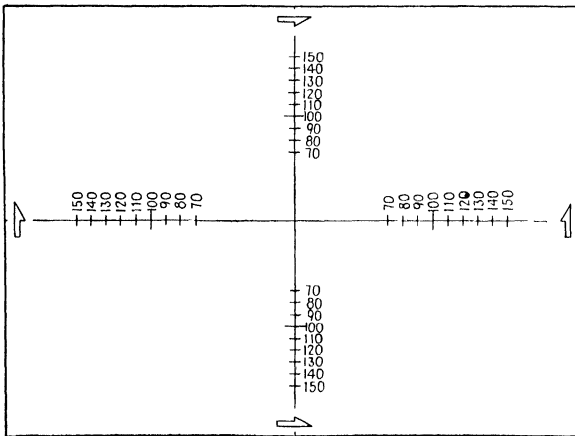

FIG. 160.—A projection easel template.

4. Draw arrows on the constructed perpendiculars to correspond to those made by the fiducial points near the edge of the cardboard.

5. Scale off distances on the perpendiculars equal to the distances between the fiducial marks on the films, and mark them as having a ratio factor of 100. The intersection formed by constructing the perpendiculars divides this distance into two equal parts.

6. Construct marks, on the perpendiculars, above and below the 100 ratio factor representing other factors. Each line leading to the fiducial points will resemble a scale.

7. Number each division with its proper ratio.

**How to Use the Projection Easel Template.**—1. Place the template on the easel with the arrows pointing in the same direction as those on the film.

2. Scale and focus the negative until the fiducial points correspond to the mean ratio factor determined, and intersect all four divisions

made on the graphic scale of the template. It might be necessary to tilt the easel slightly in order to make them fall on the correct divisions.

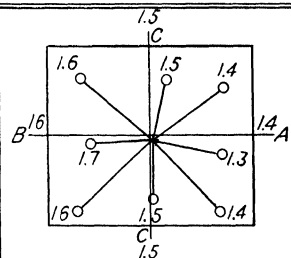
<i>RATIO COMPUTATION</i>			<i>Print No. 1-21</i>
<i>PRINT SCALES</i>	<i>BASE SCALES</i>	<i>BASE/PRINT</i>	
16.4	24.60	1.5	
17.2	24.08	1.4	
16.0	20.80	1.3	
18.6	26.04	1.4	
16.8	25.20	1.5	
19.0	30.40	1.6	
15.8	26.86	1.7	
18.0	28.80	1.6	
		---	
		<i>Ave 1.5</i>	<i>Mean scale 1" = 1000 feet</i>
<i>Projection sheet Scale 1" = 1500'</i>			<i>Ratio factors</i>
			<i>Short side 1.6    Long side 1.4</i>

FORM 14.—A practical ratio computation sheet showing an excessive tilt. The tilt axis is also determined.

3. Determine the tilt axis, and tilt the easel until the fiducial marks fall on the correctly ratioed divisions of the template.
4. Lock the easel, and place sensitive paper on the easel for exposing.

## CHAPTER XIV

### TEMPLATE METHODS OF RADIAL LINE CONTROL

#### HOW CELLULOID TEMPLATES ARE MADE AND USED

**Identifying Primary Control.**—In order to prepare an accurate map from information obtained from aerial photographs taken in flight strips and overlapping the prescribed 60 per cent in line of flight, it is necessary that the photographs be properly oriented with respect to each other and to a system of ground positions (primary control) accurately established by triangulation or traverse.



FIG. 161.—Plotting ground positions on a map base.

If a sufficient number of ground positions have been previously established so that several appear on each photograph in the area to be mapped, the problem of orientation is not difficult; but this condition, desirable as it is, will be found to be rare. In mapping with single-lens cameras, such primary control may be as much as 100 photographs apart.

In order then to orient correctly all photographs in a project that covers areas in which no primary control had been established,

it is necessary that some means be found to carry forward the primary control that does exist, through all the photographs in the area by means of image points (secondary control) on the photographs themselves. This problem of orientation is satisfactorily solved through a system of radial triangulation termed *radial line control*.

In this method a system of intersections is used that makes it possible to obtain accurately the true planimetric positions of a large number of secondary control points, thus establishing a secondary control net.

As has been stated, the horizontal and vertical positions of a certain amount of ground control, referred to hereafter as primary control, either must exist from some previous survey, or must be established by precise surveying methods.

In radial line work, no vertical control is essential. It is well, however, to keep vertical angles when traverses are run. Such station elevations can be used later for contouring or if plane-tableing is to be carried on in the field.

No rules can be made for the necessary density of this primary control. It will ordinarily be found that the primary control already in existence in any given area will be insufficient to meet the standards of high-accuracy mapping. This being true, it may be necessary to establish some additional primary control. This control may be determined from either triangulation or traverse. Traverses by transit and chain or stadia permit better placing of control than does triangulation, because road systems are usually followed, and road crossings are one of the best types of control for identification on the photographs. This primary control can be run either before or after the pictures are taken. However, it is desirable that the field parties take a set of the photographs into the area with them so that they can make the best possible selection of points that will be clearly visible on the photographs and at a good average elevation. A complete description of all primary control points established must be written up by the field parties. When possible, it is also desirable that these points be identified and accurately marked on the photographs as each point is established. Each point thus obtained should be carefully pricked with a fine needle and a small circle should be drawn around it with red ink or pencil.

In running this primary control, two or three points must be established that are clearly visible on the photographs at the beginning and ending of each flight. Since in running the traverses in this manner it is necessary to cross each flight anyway, it is well to establish and identify control in the overlap between flights as

they are crossed. In addition, several points along the outer flights are desirable (see Fig. 162) on primary control distribution.

The above suggestions concerning primary-control distribution are written on the assumption that the area being mapped can be

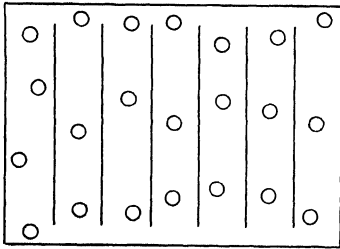

FIG. 162.—Proper distribution of ground control on a map base.

occupied by a field party. In military mapping, this might be entirely impossible. With no available triangulation information of areas in enemy territory, primary control would have to be established behind friendly lines. The photographs could then be oriented to this, and the control could be carried forward through image

points on the photographs themselves as far as required. With no primary control upon which to close at the end of the strips, the planimetric positions of all secondary control, as established by the radial line intersections, would have to be accepted.



FIG. 163.—Identifying field control from a map by using a stereoscope with the photographs.

**Compilation Procedure for Celluloid Templates.**—Having received the photographs of the area in question with all primary control accurately established and marked, the remaining steps in the compilation are:

The principal point of each photograph is located, pricked with a very fine needle, and circled with blue ink or pencil.

Because of the 60 per cent overlap allowed between photographs in the line of flight, each photograph will show the principal point of the photograph immediately preceding and succeeding it, as well as its

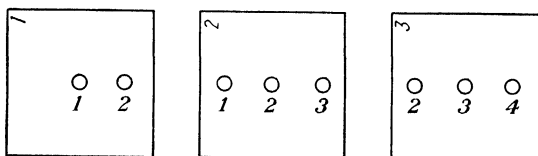

FIG. 164.—Location of principal points on three overlapping photographs.

own. Each photograph will then show three principal points encircled in blue (see Fig. 164).

These principal points must be located on each photograph with extreme care. The principal point of each photograph, where it appears on the photographs preceding and succeeding it, must be

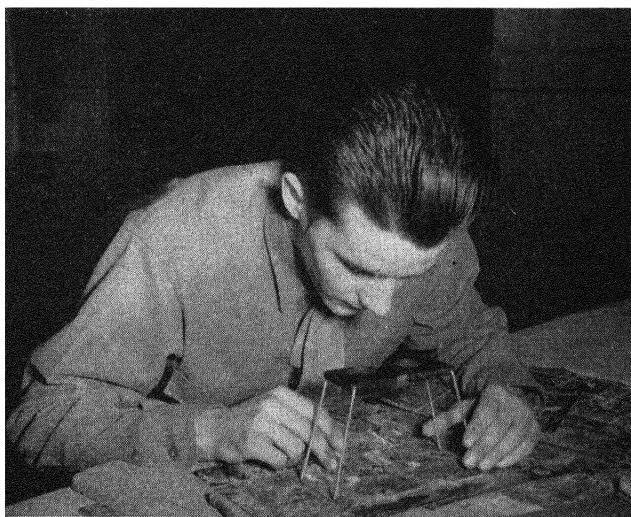

FIG. 165.—Pricking and transferring principal points with the stereoscope.

positively identified and pricked with absolute accuracy. Should the principal point of a photograph fall on a point that cannot be positively identified on the other photographs involved, it is best to choose some easily identifiable point close to the principal point, not farther away than 0.1 in.



Although this will introduce some error due to elevational displacement and tilt, it will be found that much greater error will be introduced during the compilation through inaccurate transferring of points.

When the principal points fall in water or on other plane surfaces with no identifiable points close by, the principal points must be transferred stereoscopically.

**NOTE:** In all steps in the compilation that involve the transferring of points to other photographs or the identification of points on photographs, the stereoscope must be used.

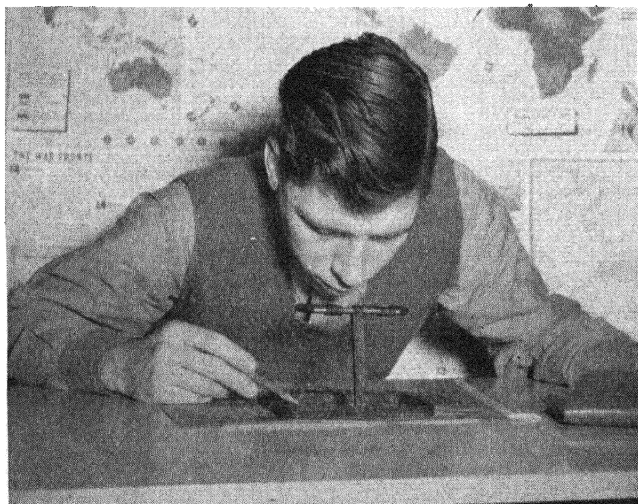

FIG. 166. —Selecting radial-line-control points with a stereoscope.

**Identifying Secondary Control.**—Next in the compilation are the selection and transferring of the secondary control on the photographs. These are the picture control points that are used to extend the primary control through the photographs that cover areas in which no primary control has been established.

Six of these secondary control points must be selected in every photograph and circled with yellow ink or pencil, making a total of nine secondary points including centers. This is a minimum. The more of these points that are selected, the greater is the accuracy of the finished map, and the greater the ease of compilation. The points selected for the secondary control must be in two distinct rows in the overlapping area on the photographs between flights, so that these same points will be shown in the adjacent flights of

photographs. Figure 167 shows clearly the distribution of the secondary control, where it will be located on each photograph and those adjoining it.

The image points selected for the secondary control must be points that can be readily identified on all photographs on which such control occurs. They should be situated at as nearly an average elevation of the terrain as possible.

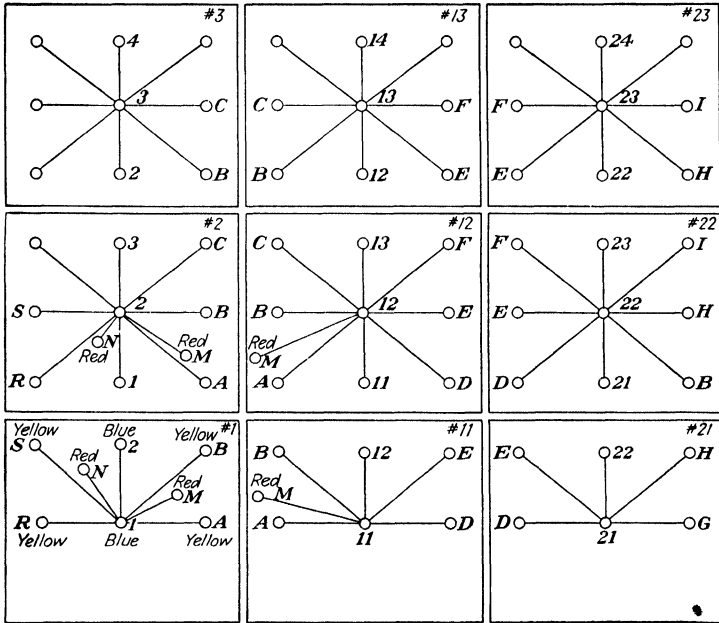

FIG. 167.—Picking and transferring radial-line control on three separate flights.

These points should be chosen at road intersections, at fence corners that are clearly definable, along railways, etc. When buildings are used, it must be remembered that the point chosen must be the exact intersection of the building with the ground.

It must be remembered that the six secondary control points mentioned are a minimum to apply only when the terrain is comparatively level. As the terrain becomes more rugged, more of these points must be selected until as many as 15, including the center points, may be located on each print.

**The Projection Sheet.**—The next step in the compilation is the preparation of the projection sheet of the area to be mapped. This is a sheet of celluloid large enough to cover the area or some reasonable

section of it. On this sheet should be very accurately drafted the map projection of the area to be mapped at the average scale of the photographs or some other desired scale. The existing primary control in and about the area should be plotted on this projection. This primary control must, of course, be plotted accurately in its true geographic position.

**Preparing the Template.**—These templates should be somewhat larger than the photographs used in conjunction with them, or about 8 by 10 in. in the case of 7- by 9-in. photographs. They are made of transparent celluloid with a thickness of about 0.006 in. The ink to be used in marking them should be some good ink that can be used on celluloid.

Number each template to correspond to the number of the photograph whose control it is to represent.

Place template 1 over photograph 1 and hold in place with thumb-tacks in the extreme corners.

Drive a small needle vertically into the celluloid precisely over the principal point of photograph 1. This needle should be allowed to remain in this position to be used as a guide for the straightedge used in the following step.

Draw fine lines from this principal point to each of the other control points appearing on the photograph. This means that a line will be drawn from the principal point to each secondary control point, a line to each of the two principal points of preceding and succeeding photographs, and a line to each primary control point appearing on the photographs. These lines may be drawn in the color of ink corresponding to the color of the ink used in making the various controls through which they go. This may be done or not as desired. However, the compilation is greatly facilitated by drawing lines to primary control in the same color as that which was used in marking the primary control. Black ink or fine etched lines will prove satisfactory for all other radial lines.

A solid line from principal point to control point need not be drawn. It is sufficient to draw a line  $\frac{1}{2}$  or  $\frac{3}{4}$  in. either side of the control point.

In this manner make a template for each photograph involved.

It must be kept in mind that the care and accuracy that should be exercised in performing the procedures outlined cannot be over-emphasized.

**Orientation of the Finished Templates and Extension of Control.**—Lay template 1 on the projection sheet.

Orient the template until the radial lines that correspond to the primary control established on the photograph pass through their

respective primary control points as plotted on the projection sheet. This orientation should be precise. Fasten template 1 in position on the control sheet with scotch tape.

Template 2 is next placed in position on the projection sheet and oriented so that the radial lines on template 2, which correspond to the same primary control as that used in orienting template 1, pass through those positions on the projection sheet. Assuming our case to be a duplicate of that presented in Fig. 167, and referring to photographs 1 and 2, we see that we first orient template 1 to primary control  $1N$  and  $1M$ , as established on the photographs and plotted on the projection sheet. Then we orient template number 2 to this same primary control as established on photograph 2.

In the orientation of these two templates we have thus formed radial line intersections with lines  $1A-2A$ ,  $1R-2R$ ,  $1B-2B$ , and  $1S-2S$ . These intersections represent the planimetric positions of secondary control points  $A$ ,  $B$ ,  $R$ , and  $S$ .

It is important that the principal point of template 2 falls on the radial line running from the principal point of template 1 to the principal point of template 2. If this condition does not exist after the orientation of any template in the area, the azimuth of the control plot will not hold true between the primary control points.

Template 2 is now held in position with weights.

Next place template 3 in position so that its radial lines pass through the intersections representing the corresponding points on templates 1 and 2.

When this adjustment has been carefully made, the three templates should be fastened to each other with scotch tape.

Templates 4, 5, 6, etc., may now be adjusted to templates 2 and 3. These adjustment are carried on from template to template until more primary control points are reached. The radial lines representing this primary control should intersect at the position of the primary control, as plotted on the projection sheet. Some slight stretching and adjustment of the entire strip of templates may be necessary in order to close upon the primary control.

When this adjustment has been satisfactorily completed, the rest of the templates in the strip are oriented to their respective positions.

The templates in each flight strip comprising the area are then oriented and adjusted as described.

Each point, formed by the intersections of the radials, drawn from the secondary control, now represents the exact planimetric position of the secondary control oriented to its true planimetric position in relation to the established primary control.

**Transferring the Control.**—The points formed by the intersections of the radials drawn from the secondary control, as well as each center point, must be transferred to the projection sheet. A practical method is as follows:

Make sure that the entire group of templates is accurately adjusted so that the proper intersections are formed by the radial lines from the secondary controls, that the primary-control intersections throughout the group of templates coincide with the primary control plotted on the projection sheet, and that the entire group of templates is lying flat on the projection sheet. Then prick through each intersection of secondary control and each center point. Circle each center and secondary point thus pricked, with the proper colored ink, on the side of the projection sheet that is not to receive the topographic drafting. The templates may now be removed and stored away.

The projection sheet now has appearing upon it, in addition to the primary control established in the area, a network of secondary control, each point appearing in its true planimetric position. We have thus increased and strengthened by many times the network of control to which the map detail can be adjusted.

**Tracing the Detail.**—If the preceding work has been carried on at the average scale of the photographs, the detail may be traced from the photographs directly to the projection sheet. Place photograph 1 under the projection sheet, and orient the primary and secondary control appearing on the photograph to the corresponding points on the sheet.

Because of the displacement of image points on a photograph due to tilt and relief and slight scale changes between photographs, exact coincidence of the secondary control points on the photographs with the corresponding points as now plotted on the projection sheet will rarely be encountered.

In this case, orient photograph 1 so that coincidence is made between the primary control on the photograph and that on the projection sheet. Shift the print under the projection sheet, bringing these points into coincidence with the corresponding points on the sheet, and trace the detail enclosed by these points and for a short distance toward the next nearest control. In this way control points will be brought into coincidence as the detail immediately surrounding each point is traced. Continue in this manner with each photograph in the area until all the detail has been transferred to the projection sheet. This tracing of the detail requires very careful and accurate work on the part of the draftsman.

The correct colors and topographic symbols should be used in representing the detail as traced from the photographs (see the chapter on Topographic Drafting).

After all the desired detail has been traced on the projection sheet, the names of rivers, lakes, towns, roads, etc., should be added in neat hand lettering or with the aid of a lettering guide, and the proper title should be constructed and placed in a suitable position on the map. The finished projection sheet may now be copied and reproduced by any of the various methods of map reproduction.

**Change of Scale between Base and Print.**—If the projection sheet is plotted with its grid of latitude and longitude at a scale different from the average scale of the photographs, it is necessary to compute the ratio of scale change between the photographs and the projection sheet; and a photographic process of enlargement or reduction will have to be carried out to bring the primary and secondary control to this different scale. This can be accomplished in the following manner:

Beginning with photograph 1 and using a scale graduated in 0.01 in., measure from the center point of photograph 1 to the center point of photograph 2, where it appears on photograph 1. Enter this reading in the column headed Print Scales on the ratio computation sheet in Form 15. Number this sheet to correspond to the number of the photograph.

Moving clockwise around the print, measure from the center point to each point of control, primary and secondary. Enter these readings in their proper order under Print Scales. Repeat this operation for all photographs involved. Following the same order and using the same unit of measure, measure the corresponding distances to the control as established on the projection sheet. Enter these readings in their proper order under the column headed Base Scales.

Divide each base scale by its corresponding print scale, and enter in the column headed Base/Print.

Each quotient thus obtained will represent the ratio of enlargement or reduction necessary to bring the scale of that photographic distance to the scale of the corresponding projection sheet.

An average of all the ratios of Base/Print for each print will indicate the amount of enlargement or reduction necessary to bring the scale of the print to the scale of the projection sheet.

In the example outlined in Form 15, the projection-sheet scale is 1 in. = 1,000 ft. The mean scale of the photograph by computation is 1 in. = 1,400 ft., a figure obtained from an average of the Base/

Print ratio factors. This means that photograph *FM21-26* will have to be enlarged 1.5 times before its mean scale is equal to that of the projection sheet.

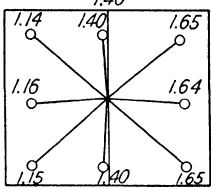
<i>RATIO COMPUTATION</i>			<i>Print No. FM-21-26</i>
<i>PRINT SCALES</i>	<i>BASE SCALES</i>	<i>BASE/PRINT</i>	
2.50	3.50	1.40	
2.30	3.80	1.65	
1.20	1.96	1.64	
3.42	5.64	1.65	
2.62	3.66	1.40	
3.36	3.86	1.15	
2.08	2.41	1.16	
3.21	3.75	1.14	
			<i>Ratio factors</i>
			<i>Short side +1.15 Long side +1.645</i>

FORM 15.—Ratio computation sheet.

The points of control for the photograph are then plotted in their approximate relative positions in the rectangle provided in the upper right of the computation sheet, and the ratio factor for each

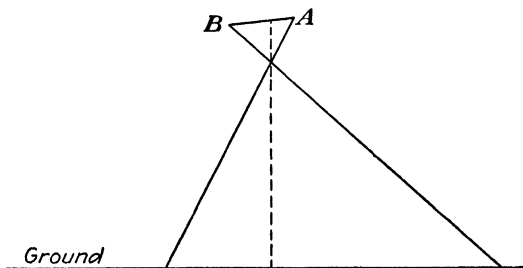

FIG. 168.—Diagram showing the relationship of the film to the ground when the camera is tilted.

point is written beside that point. Study of the resulting diagram will furnish an indication of the direction and amount of tilt existing in that photograph.

*Example.* Side *B* is the depressed side of the camera and is consequently at a smaller scale; therefore any distance on side *B*, being shorter than it would be at projection-sheet scale, will have to be enlarged 1.6 times.

Side *A* is the raised side of the camera and is therefore at a larger scale. It will have to be enlarged 1.4 times.

For the technique of the actual laboratory procedure, refer to Chap. XIII.

#### HOW SLOTTED TEMPLATES ARE MADE AND USED

This method of making templates differs from the celluloid-template method in the following respects:

1. The templates are made from stiff cardboard.
2. Slots,  $\frac{1}{8}$  in. wide and about 2 in. long, replace the radial lines on the celluloid templates.
3. Pin guide shafts, or studs, which fit with a very close tolerance into the radial slots but are capable of moving freely along the length of the slot, are used to establish radial intersections and to hold the assembly rigid.
4. The projection sheet, or base, ordinarily consists of some hard-surfaced composition board, or suitable light metal sheets, rather than acetate or celluloid. The template assembly is carried out; and the control extension established on this base is transferred to an acetate or celluloid control sheet.
5. A special template cutter, for cutting the radial slots in the cardboard templates, is necessary.

**Compilation Procedure—Slotted Templates.**—The photographs to be used in the slotted template assembly are prepared with the same procedures and considerations as those outlined in the discussions in Chap. IX. Once the photographs have been prepared, the compilation is as follows:

Tape the first photograph to the template cardboard and, using a fine needle, prick each principal point and each primary and secondary point through to the template. Hold the needle exactly perpendicular to the surface of the photograph, and prick through only far enough to register a tiny hole in the cardboard beneath each point.

Remove the photograph and circle with pen or pencil each point pricked on the template material.

Check the points thus established on the cardboard against those on the print, to be sure that none of the points has been overlooked.

If there is any possibility that the photograph has moved during the operation, the template must be discarded and the step repeated.



The photograph number is placed on the template at the principal point and so situated that the direction of flight is indicated by its position.

Draw a fine line from the principal point to each point thus pricked on the template, to serve as a guide for the template cutter.

Using a punch the exact size of the outside diameter of the pin guide shafts, punch out the exact principal point as located on the template.

The template thus prepared is ready to be cut on the template cutter. This cutter will usually consist of a fixed platform, in which is built a stud of the same outside diameter as the pin guide shafts to be used, so constructed as to be free to move along a channel in the platform toward and away from a hand-operated cutting bar

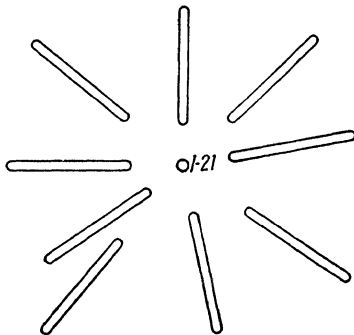

FIG. 169.—A cardboard slotted template.

or die, which is capable of cutting a slot in the template material of the same width as the pin guide shafts, and about 2 in. long.

Place the template on the cutter with the hole in the template, which represents the principal point of the photograph, fitting snugly over the stud in the cutting platform. By rotating the template around the stud and adjusting its position along the channel, line up a radial line on the template with the cutting die

in such a way that, when the handle is depressed, a slot extending about half its length on either side of the radial point will be cut. Repeat this operation carefully for each radial line on the template.

Inasmuch as the accuracy of the entire compilation depends on the accuracy with which the above steps are accomplished, the procedures outlined must be performed with the utmost care.

The resulting template will be similar in appearance to the example shown in Fig. 169. A template is constructed in this manner for every photograph to be used.

**The Projection Sheet.**—The projection sheet, or base, will be of some hard-surfaced material that will take very fine ink lines and is not unduly affected by temperature change and humidity. It must be of such a consistency that the pin guide shafts, to be used to represent primary control, can be rigidly fastened to it, either by driving a pin down through the shaft into the material, or by gluing

or cementing. Two such surfaces which prove satisfactory are the composition materials Presdwood and Vehisote.

Construct a suitable map projection at the desired scale on the base. On this projection, accurately plot the primary control.

Running a pin down through a pin guide shaft or stud, and holding the stud in such a way that the point of the pin can be brought into exact coincidence with a primary control point, plotted on the base, use the shaft for a guide and drive the pin firmly into the base material.

The pin and pin guide shaft must be absolutely perpendicular to the base and embedded deeply enough that there can be no possibility of the shaft's changing its position during the subsequent adjustment of the group of templates.

In this manner, place a pin and pin guide shaft exactly over every primary control point plotted on the base.

**The Template Assembly.**—Beginning at the first primary control point, take up the template corresponding to the first photograph on which that point appears and lay the template on the base so that the slot in the template that radiates to that point falls over the pin guide shaft indicating the position of the point on the base. Orient the template about this point so that the slot that runs from the center of template 1 to the point representing the center of the succeeding template lies in the direction of flight.

Place the succeeding template (template 2) in position on the base, with the slot that radiates to primary control point 1 falling over the pin guide shaft representing that point, as did the corresponding slot in template 1. Orient template 2 around the point so that the slot that radiates to the center point of template 1 falls over that center point.

Run a pin guide shaft up through the center point of template 1 and through the slot on template 2 that radiates back to that point.

Run a pin guide shaft up through the slot in template 1 that radiates to the center point of template 2 and through that center point.

At the point of intersection of the slots corresponding to secondary control, place a pin guide shaft so that the shaft projects up through the slots where they intersect.

These intersections will ultimately represent the planimetric positions of the secondary control points.

Repeat this operation with each template in the flight strip, tying into each primary control point as it is reached; carefully orient and adjust the templates about the points so that, when the control at the end of the flight strip is reached, each template will

lie perfectly flat without any tendency of the pin guide shafts to dig into the edges of the slots or of the templates to buckle.

If a template will not tie in perfectly with the points about it, some error has been made in the preceding work that must be remedied.

Having completed the assembly of the first flight strip, begin the second strip with the template that ties into the first ground control point, and continue the assembly as described. Continue in this manner with all templates in each flight strip.

Each pin guide shaft at the center points and at the intersections of radial slots now represents the true planimetric position of the principal points and secondary control points, plotted on the photographs throughout the area.

Run a pin down through each pin guide shaft in the assembly, and with a light hammer tap each pin with sufficient force to register a small hole in the base. When this has been done for each center and secondary control point, the templates may be removed. At the same time circle each point pricked on the base with a suitable color of pencil or ink, and identify each principal point by printing the template number beside it.

The templates should now be filed away in their proper order. The network of control thus established can be transferred to a transparent compilation sheet simply by taping a sheet of acetate or celluloid to the finished base and with a fine needle pricking the position of each principal point and each primary and secondary control point on the celluloid sheet, circling each point and identifying each center in the manner described in preceding discussions.

#### **HOW MECHANICAL TRIANGULATORS ARE USED**

The system of radial control by means of mechanical triangulators is an adaptation of the slotted-template method.

Slotted templates were the result of endeavors to find a system of radial control that would provide a network of radial intersections more rigid than was possible with the celluloid hand templates.

An assembly of mechanical triangulators provides as rigid a network of intersections as do the cardboard templates and in addition eliminates certain mechanical inaccuracies of the cardboard templates. The individual arms of the mechanical-triangulator templates, being of metal, eliminate the tendency of the studs to dig into the comparatively soft material of the cardboard templates.

The metal templates, as a result, tend to adjust themselves more readily. Furthermore, during the machining of the metal template arms, closer tolerances can be maintained between the diameter of

the stud and the width of the slot. Then too, the metal templates can be dismantled after use and used again and again, whereas the cardboard template can be used to represent only the particular photograph from which control was taken.

**Equipment.**—Typical of mechanical-triangulator equipment is the kit manufactured by the Abrams Instrument Company. This kit comprises a wooden case, containing 1,233 separate pieces, or

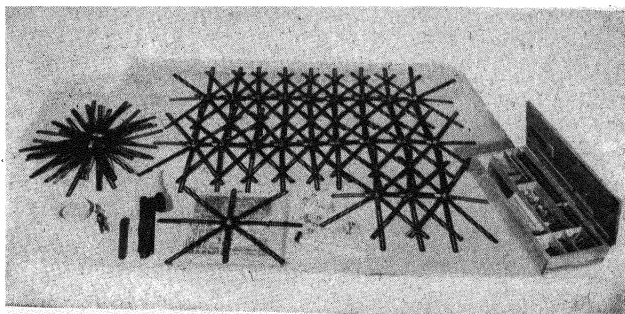

FIG. 170.—The mechanical-triangulator kit.

enough to extend control over 100 photographs. The kit contains the following items:

1. Retaining nuts.
2. Pin guide shaft  $\frac{3}{4}$  and  $1\frac{1}{8}$  in. long.
3. Pin guide bushings.
4. Pins—with and without heads.
5. Radial arms—three sizes from 3 to 9 in. long.
6. Spintite wrench.
7. Flat wrench.
8. Tack hammer.

**Steps in Preparing Lazy Daisy Mechanical-triangulator Templates.**

1. Identify the principal points, control stations, and radial line control points, in exactly the same manner as outlined for the preceding methods of radial line control.

2. Take up the first photograph, and place it on a piece of soft board, slightly larger than the print (preferably Homosote). Set a rule to keep the prints oriented in the same position.

3. Insert a pin through a  $1\frac{1}{8}$ -in. pin guide shaft and over the principal point of the photograph.

4. Place the pin guide bushing over the center pin guide shaft.

5. Insert pins through the  $\frac{3}{4}$ -in. pin guide shafts and into all points identified on the photograph.

6. Place a radial arm with the circular hole over the uppermost stud. Be sure to select the arm with the correct length. The stud,

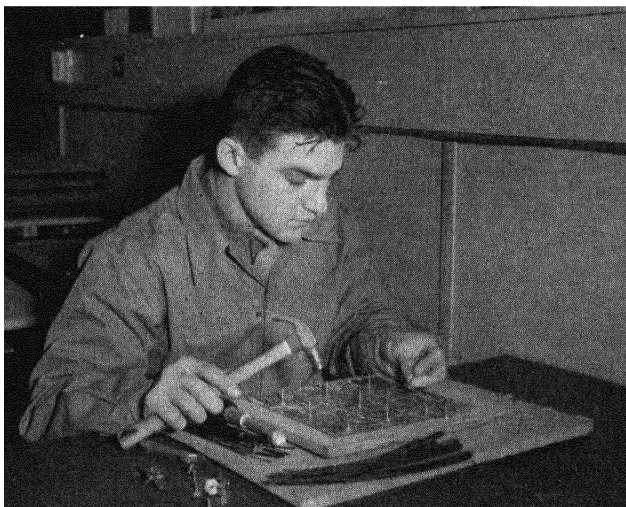

FIG. 171.—Inserting pins in a photograph.



FIG. 172.—Placing radial arms over the pin guide shafts.

or pin guide shaft, should fall near the center of the slot to give the maximum amount of adjustment.

7. Select arms of the proper length and place them over all pin guide shafts in a clockwise direction.

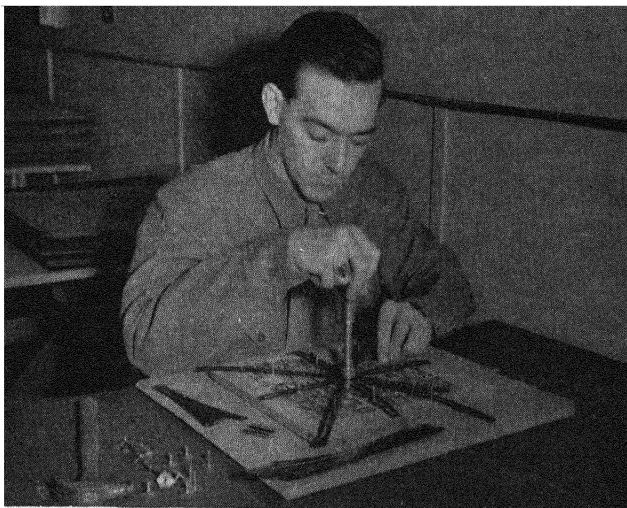

FIG. 173.—Placing a retainer nut over the bushing and tightening.

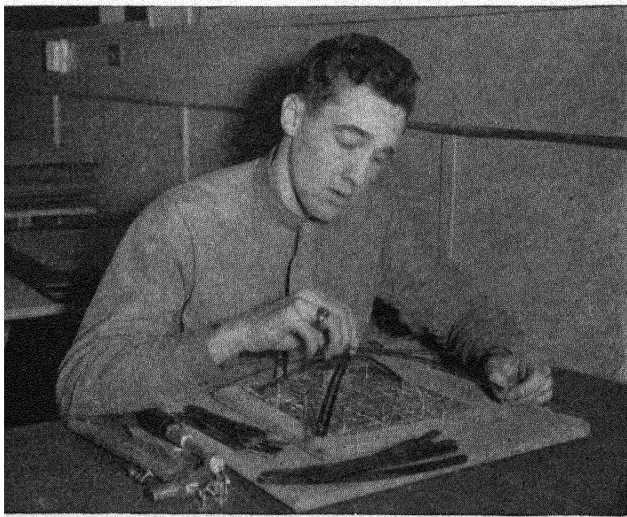

FIG. 174.—Removing the template from the print.

8. Place a retaining nut over the center pin guide bushing, and tighten it firmly with the spintite wrench. Be sure that all arms

remain over the pin guide shafts. If the pin guide bushing turns, it can be held underneath by a specially built flat wrench, one of which is in each kit.

9. Identify the completed template by numbering it with the number of the photograph whose control it represents. The entire compilation is facilitated by placing this number on the template arm radiating to the shaft representing the principal point of the succeeding photograph. The individual orientation of each composite template is greatly aided by numbering in this manner.

10. Identify each arm radiating to ground control points.

11. Remove the templates from the pin guide shafts, and stack them in a convenient pile for assembly.

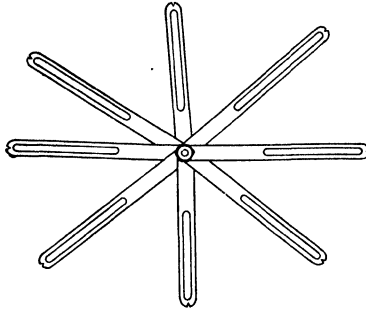

FIG. 175.—A complete mechanical-triangulator assembly.

12. Remove the pin guide shafts, and file away the print.

13. Repeat the steps outlined in 1 to 12, inclusive, for each photograph in the area.

14. Keep the finished templates of each flight strip in separate groups.

**NOTE:** The utmost care and accuracy must be maintained throughout this operation. Picture points must not be defaced, for the prints might be needed again for checking templates that do not tie together in the assembly.

**Assembly and Orientation of Templates.**—1. Fasten pin guide shafts permanently over located known control points of the base sheet.

2. Lay template 1, which is the first or last template of a flight strip, to its estimated position on the base sheet.

3. Insert template 1 base line arm under template 2, and fasten it to center pin guide shaft of template 2.

4. Place template 2 base line arm over center pin guide shaft of template 2.

5. Continue this procedure for all templates throughout the flight, as described in steps 3 and 4.



FIG. 176.—Laying up a strip of mechanical-triangulator assemblies.



FIG. 177.—A complete mechanical-triangulator assembly lay-down.

6. Place the arms, marked as control stations, over the stationary pin guide shafts located on the base sheet. These known located



points, if accurately plotted, will properly orient the other points picked throughout the flight to their true geographic positions.

7. Proceed to assemble flight line 2 from the same end, as was done for flight line 1.

8. Place the arms marked for control stations over the stationary pin guide shafts, and insert the pin guide shafts through all intersecting radial arms formed between the two flights.

9. Carry this procedure along for each flight strip until the project has been covered.

10. Insert pin guide shafts through all intersecting arms.

**Errors Common in the Compilation.**—If some of the arms do not form radial line intersections, then an error has been made in the compilation, which could be caused by one or more of several things:

1. Improperly constructed base sheet.
2. Picture points improperly identified or transferred.
3. Horizontal control stations improperly plotted.
4. Carelessness in placing pin guide shafts over picture points.
5. Template arms becoming loose, or radiating in improper directions.

6. Template improperly inserted as to its correct orientation.

7. Template arms binding or catching on one another.

8. Defacing of picture points so that they have enlarged holes.

9. Tightening arms while they are not over pin guide shafts.

After the entire assembly has been made and the pin guide shafts have been inserted in all intersections, the lay-down should be rigid for the entire area. Then steel pins are inserted into all the shafts and driven into the base sheet with a small hammer. These newly pricked points are the true locations of the picture points, accurately oriented to the scale of the base sheet.

## CHAPTER XV

### HOW TO MAKE A MOSAIC FROM AERIAL PHOTOGRAPHS

**Definition.**—An aerial photographic mosaic is an assembly of individual aerial photographs, made by matching images to form a single picture.

Since the First World War, mosaics have become a valuable source for obtaining map information, both by the government and by private concerns. They can be produced in various scales to show large areas or such areas as individuals might desire. Maps from mosaics have been made to as large a scale as 1 in. = 40 ft. Others have been made to as small a scale as 1 in. = 40,000 in. The two prime reasons that mosaics are more valuable than other maps are

1. They can be hurriedly assembled, saving much time and labor. This makes them very valuable in wartime. Mosaics good enough for military purposes can be made within a few hours from the time the photographs have been taken. Photographs of the most strategic areas where interpretations are to be made can be studied stereoscopically in conjunction with the mosaic to determine enemy movements and methods of attack.

2. A mosaic shows more planimetry at a scale truer than that in any other type of map. Every feature produced in an aerial photograph assumes its natural appearance and its exact dimensions. No group of topographic symbols has yet been devised to show all the true characteristics of different objects as they can be interpreted from aerial photographs. The amount of detail to be observed from a mosaic, of course, depends on its scale.

**Requirements in Making a Good Mosaic.**—Literally we think of a mosaic as being the art of masonry—joining pieces of glass, tile brick, or stone to form some pattern desired. Photographic mosaicing is also an art in itself and is similar except that there are no joints or variable color matches throughout the pattern.

In mosaics, match lines are concealed and everything possible is done to make the combination of different pieces resemble one single picture. The appearance of a mosaic depends on:

*The Skill of the Mosaicist.*—Anyone classified as a good mosaicist must have several months of instruction and practice. It is an

art acquired only by long experience and patience. Speed cannot be expected of anyone unless he has had adequate experience. As is common in all trades, some adapt themselves faster than others. The skill of the mosaicist controls the appearance of the mosaic more than anything else. To assemble any mosaic he must also have a thorough understanding of the area and the proper tools to do the job.

*The Characteristics of the Terrain.*—An area very flat and level is much easier to mosaic than a rugged, mountainous terrain. A vertical picture having hills and valleys has various scales within



FIG. 178.—In the process of laying a mosaic.

itself; thus it is hard to make one photograph match the adjoining one without leaving mismatches of double images or overlaps. Prints of such areas should always be restituted to a common datum plane scale, and the remaining errors distributed throughout the strip by holding the mismatches to a minimum.

*The Color and Tone of the Photographs.*—All photographs used in a mosaic should be time-developed at a given temperature and printed to a good contrast and density. If this is practiced, it will be easy to produce an even tone and color throughout the survey. Prints off color and tone should not be laid, and remakes should be ordered if it is possible to do so. If remakes are made, they too must be of the same grade and contrast as of the first printing. Sometimes prints having an off color can be eliminated, provided there is plenty of overlap.

Color match can be greatly improved by the skill of the mosaicist in trimming the photographs for the lay-down. They should as much as possible be trimmed along an even color match to the adjoining print. Great improvement can be made by trimming along a fence line or edge of a woods. A mosaicist should never trim along roads, because the slightest mismatch will be very noticeable. Difference in color and tone can also be improved by overlapping the lighter print onto the darker one.

*Distortion and Displacement Due to Relief.*—The outer edges of an aerial photograph have the most distortion and relief displacements; therefore we should always use the center portion of the photograph. This can be accomplished in the following ways:

1. Select a print that is to be assembled first, featheredge, and mosaic all of it.

2. Overlap the adjoining print and trim off just half of the overlap, keeping in mind the color and tone match. Do not trim very much off the outer edges.

3. Trim off half the overlap on all adjoining prints. They can then be mosaiced throughout the strip.

4. Half the overlap on adjoining strips can likewise be trimmed and assembled. This leaves uncovered the centermost portion of each photograph, which is the most accurate part of the print.

*The Difference in Scale.*—We find in all surveys some difference in scale from one photograph to another and from one strip to another. This is caused by the airplane's not attaining a constant altitude, owing to atmospheric conditions. To overcome this, prints should be restituted or printed to a common scale. If it is impossible to do this, the mosaicist should do everything he can to distribute the error throughout the strip or strips, by stretching the prints or concealing the mismatches in any way possible.

*The Quality of the Reproduction.*—In order to have many copies of a mosaic, a copy negative must be made. Copy negatives should be made to a common desired scale and with a good printing quality. They can be either enlarged or decreased as much as two times if necessary.

Although steps have been taken to keep the mosaic at the same tone, individual prints will be noticeable in the reproduction. This can be overcome by blending and retouching the copy negative with a small airbrush and red soluble dye. The red dye is sprayed on the thinnest portions of the negatives (shown by the darkest prints in the mosaic) to a certain density that will print up equal to the densest portions of the negative. The lines caused by the shadows cast from the edges of the overlapping prints can be retouched

out by a good retoucher. It takes an artist skilled in the use of an airbrush to do this operation satisfactorily.



FIG. 179.—A photographic index.

Copy negatives made of a survey should be free of tilt and have the same scale in order to match one another. They should have some mark of identification such as (Sheet 1 of 10) in order to identify their position in respect to the survey.

**Kinds of Aerial Photographic Mosaics.**—*Indexes* are hurriedly compiled photographs of the area to be mapped. Each individual photograph throughout the area is stapled or fastened together by matching overlapping images so that all data on the photograph can be seen. This particular type of mosaic assembly is used as an index in determining the number and location of individual photographs in the survey. It also is used for checking coverage and determining places necessary for ordering reflights while the project is being flown.

Many concerns use index maps as progress sheets, coloring or shading in the area as it is being completed. An index map is very convenient in locating the print numbers that are necessary in ordering remakes or for making a stereoscopic study.

*Uncontrolled mosaics* are mosaics that are laid to scale as they were flown by matching like images. No control is used in the assembly. It is a very rapid method of producing a picture of a large area. The best method in making this type of mosaic is to do everything possible to avoid an accumulation of error. This can be accomplished by laying the middle print of the mosaic first. By working from the middle of the survey, errors can be forced to the outer edges. A true azimuth of the flight line can be accomplished by mosaicing the middle strip on a straight-line method (see Straight-line Method of Control). Some mosaicists prefer to lay two strips at a time because it gives them true orientation. They can also at the same time distribute the scale error by making a rapid assembly and adjusting one strip to the other before the prints become dry and set.

*Semiconrolled mosaics* are mosaics that have direction or distances given. The prints used in this type of assembly should be restituted for scale. There are several methods used in making a semiconrolled mosaic.

1. Straight-line control involves two methods: *a.* See Straight-line Method of Control. *b.* Railroads or roads that run in a straight line can be drawn as straight lines on the mount, and prints to be mosaiced can be oriented to them. This makes the strips lie in their true positions.

2. The pantograph method is the transferring of points or lines from an existing map to the mosaic mount at a desired scale by the use of the pantograph. The pantograph is an instrument with adjustable arms that can be used for transferring data of a known measurement to some desired measurement. All prints can be ratioed and restituted to fit known distances plotted on the mount.



FIG. 180.—An uncontrolled

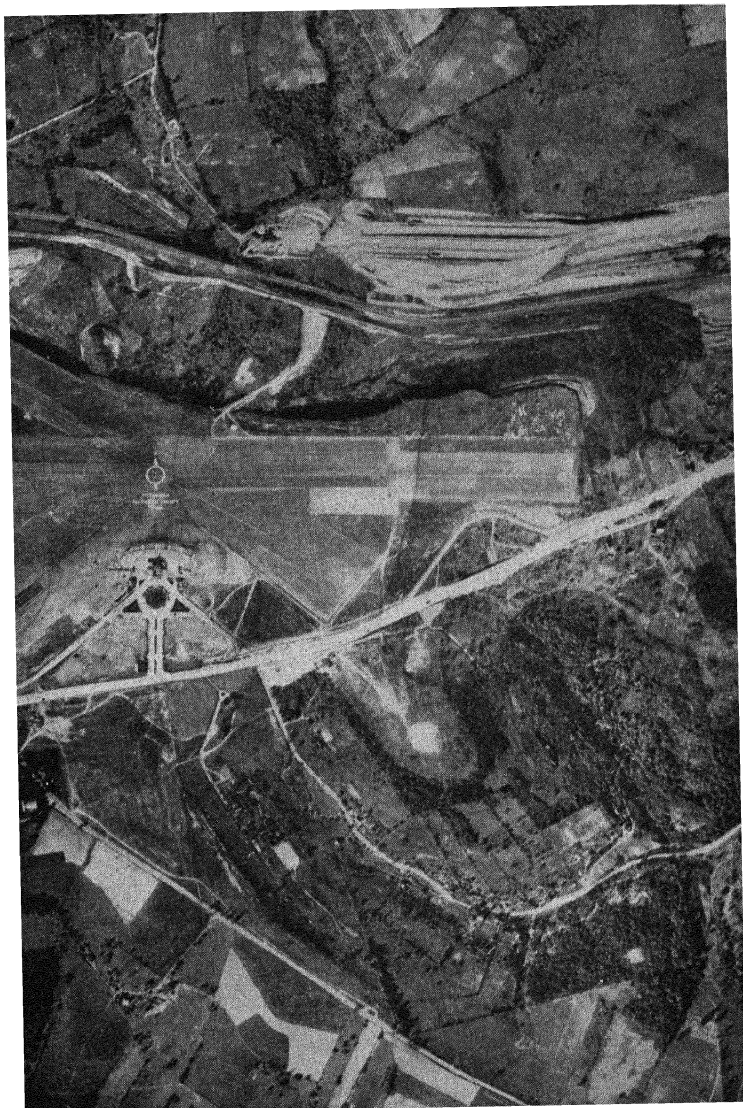

mosaic. Note the match lines.



3. With horizontal distances given throughout the line of each flight, we can compute the mean scale of the flight and project the prints to fit those measurements. Then, by using the straight-line-



FIG. 181.—A semicontrolled mosaic laid to known horizontal distances.

control method of assembly, we can get a very accurate mosaic that will have the scale that we desire.

*Controlled mosaics* are those which have been corrected for scale, tip, tilt, and displacements due to elevational differences. The prints must be ratioed and restituted. The radial-line-control method is the best method of producing enough control for making a

controlled mosaic. Each print assembled will have nine or more established locations.



FIG. 182.—Portion of a radial-line-controlled mosaic reproduction quadrangle sheet—Puerto Rico.

#### Steps in Sequence for Preparing a Mosaic :

1. *Check for coverage* and ask for reflights if they are deemed necessary. See that no prints are missing.

2. *Select Scale Desired.*—Enlargement up to two diameters can be used in a mosaic, if the scale requires it, without giving too much

trouble in mosaicing. Prints should never be reduced very much to fit a certain scale. It is better to make your mosaic to a larger scale and reduce it to the desired scale in copying.

3. *Prepare Board or Mount.*—A mosaic board should be smooth in surface, large enough to cover the area, and capable of adhering to the adhesive that is being used.

4. *Plot Control on Board.*—All control obtainable should be spotted in its proper location and marked on the mount. If a projection is to be used, make sure all parallels and meridians are tagged, so that they will not be lost in the assembly procedure. All known



FIG. 183.—Measuring distances on a mosaic.

triangulation and radial-control points should be numbered with their proper designations.

5. *Prepare Prints.*—Restitute prints if accuracy requires it. Always use those that are uniform in color. All known points on all the prints should be identified and circled with a grease pencil. If straight lines are used for assembling, they should also be drawn on the prints. Prints should be neatly trimmed, featheredged, and sandpapered on all overlapping edges.

6. *Assembly Procedure.*—After the prints are properly trimmed, the adhesive is applied to the back of the prints and each print is oriented to its position on the mount. All surplus adhesive is squeegeed from underneath the print and removed by a sponge. Care must be taken that lumps or wrinkles are not left under the print. If

too much of the mucilage is removed, the print when dry will not be attached to the mount, and a blister will be formed. Always keep the assembly as clean as possible. If surplus mucilage is left to dry on the print, a cracked emulsion will result.

7. *Draw on Grid System.*—Grids must be drawn on all military maps. They usually represent 1,000-yd. distances in the form of squares. On polyconic projections they are oriented to the geographic coordinates by the use of a set of tables prepared for the entire United States. This system divides the United States into seven zones of 9 deg. each with the principal parallel being  $40^{\circ}30'$  north latitude.

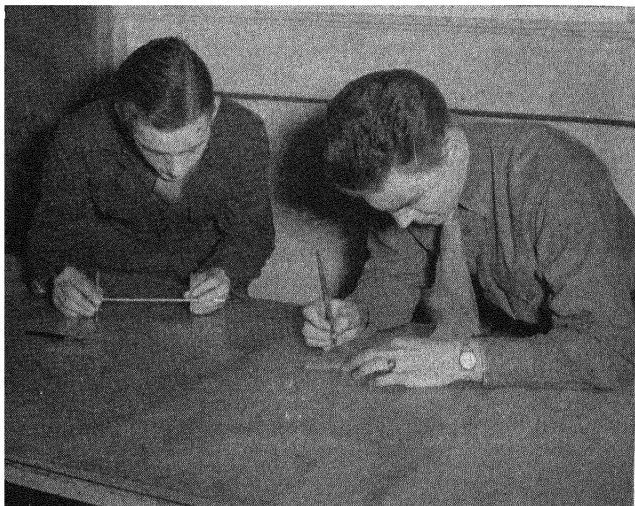

FIG. 184.—Constructing grid lines on the map base.

The zones overlap each other by 1 deg. in longitude. The purpose of the military grid is to give the map reader a method of rapidly making measurements on the map.

8. *Construct a Title.*—All maps should have a title and other necessary data to give the location and type of survey made, by whom and when the map was compiled, and some method of determining the scale. Scale can be represented by either a numerical fraction or a graphic (bar) scale. The graphic scale is the best kind to use, because it always represents the true scale of the map regardless of whether the map has been increased or decreased in size by reproduction.

9. *Make Copy Negatives.*—Copy negatives can be made to any scale desired. They should be of good density, and if possible

blended and retouched. They should be made to a certain scale so that the overlapping detail from one copy will exactly match the



FIG. 185.—Drafting a title for the completed map.

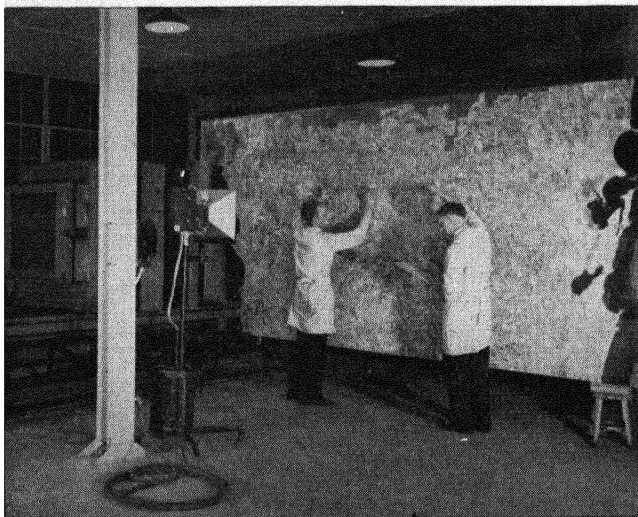

FIG. 186.—Making a large copy negative.

other. A film and paper shrinkage factor should be taken into consideration. That factor is about 0.15 in. per 10 in.

10. *Reproductions.*—Either photographic or lithographic reproductions can be made. In large surveys, they represent only certain portions, and some method of indexing should be made to represent their location in respect to the survey. In this case, they are called *atlas sheets* and can be bound into a book. Geographic lines form the boundaries of commercial quadrangle sheets, and grid lines form those made for military purposes.

**Adhesives.**—Gum arabic seems to be the best and most commonly used adhesive in mosaicing. It allows for easy adjustment of the prints and permanently seals all joints. Its chief disadvantage is that it is made up of water and absorbs into the prints, causing them to expand and become off scale. This causes considerable trouble, especially in controlled mosaics, for the paper expands more against the grain than with it.

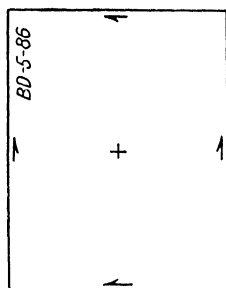

FIG. 187—Locating the principal point.

#### *Gum Arabic Formula*

Salicylic acid.....	3½ oz.
Gum arabic tears.....	5 lb.
Glycerin.....	10 oz.

Dissolve tears in 1 gal. water (120°F.) and add salicylic acid and glycerin.

Rubber cement has also been used as an adhesive for mosaics and eliminates the expansion of the prints. Its disadvantage is that it does not allow one to adjust the print to its proper position and is not a permanent fastener.

Various pastes on the market can be used for mosaicing. They often have various chemicals in them that might cause discoloration in the prints. They also are a water solvent and cause the prints to expand.

#### **Materials Needed for Laying a Mosaic**

1. Assembly board.
2. Prints of uniform color.
3. Cutting tool.
4. Sandpaper.
5. Wet or dry cloth.
6. Tray of clean water.
7. Adhesive.
8. Squeegee (small).
9. Sponge.

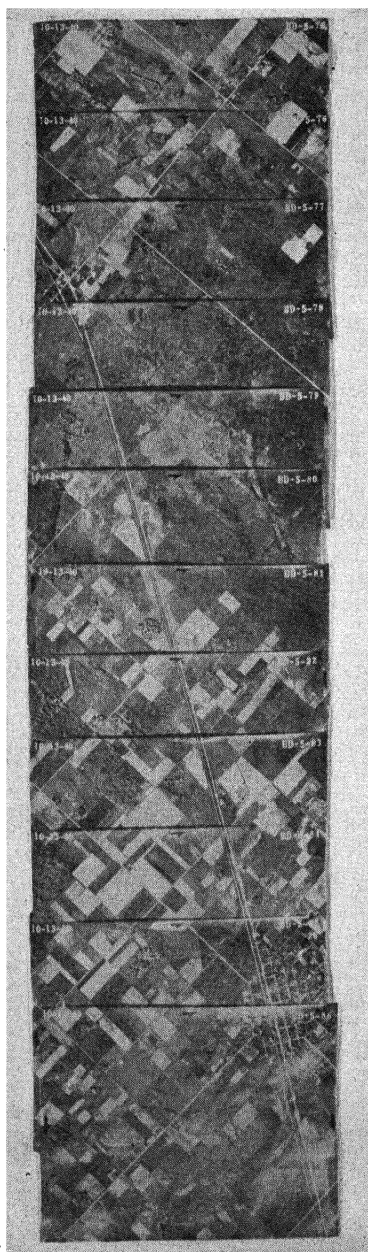

FIG. 188. - A flight strip of photographs.

10. Masking tape.
11. Straightedge.
12. Ruling pen and lettering pen.

**The Straight-line Method of Control.**—In the straight-line method, an attempt is made to orient correctly, with respect to each other, the prints in a single strip of overlapping photographs. A strip so oriented may be used in connection with certain types of military

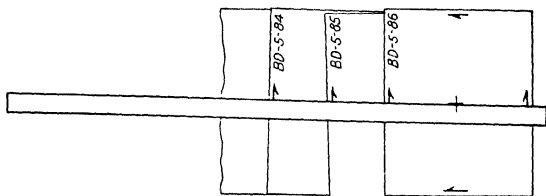

FIG. 189.—Laying a straightedge over the strip.

reconnaissance for determining average print scale from the ratio existing between ground and photograph distance. In some cases, such a strip can be used to assemble an accurate base strip to which can be assembled the remaining strips of an uncontrolled mosaic.

*Compilation.*—Determine and mark the principal point of each photograph.

On a large table or desk assemble the photographs in their proper order by matching detail (photo image points). Hold the assembled prints in place with weights or scotch tape.

Adjust a straightedge on the assembly in such a manner that its edge passes as closely as possible to each principal point. When this adjustment is satisfactory, draw a fine line along the straightedge from edge to edge of the first photograph. This particular line is drawn on only this one photograph. The photographs may now be removed from the board.

The line so drawn on the first photograph is now transferred to each of the other photographs in the following manner:

1. On the line on the first photograph, and in the area overlapped by the second photograph, identify and prick two points that can be readily transferred to the second photograph. These two points should be as far apart as possible.
2. Identify and prick these two points on the second photograph, and draw a fine line through them to both edges of the photograph.

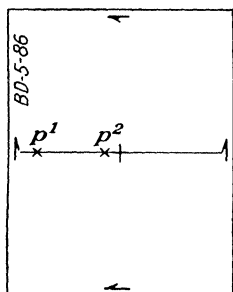

FIG. 190.—Identifying and picking points on the first photograph.



3. On this line on photograph 2, identify and prick two points that can be transferred to the third photograph.

4. In this manner lines are drawn on each photograph in the strip. When the lines are drawn in this way, any line on any of the photo-

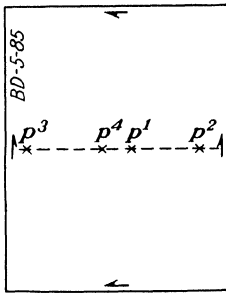

FIG. 191.—Points picked on the second photograph.

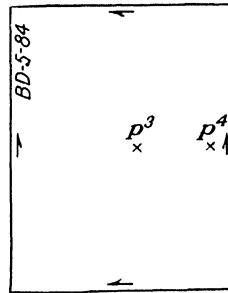

FIG. 192.—Points picked on the third photograph.

graphs will have exactly the same azimuth as any of the lines on the other photographs.

*Orienting the Photographs.*—Draw a straight line of sufficient length on some suitable base material if the strip is to be mosaiced, or on acetate or tracing paper if the detail is to be taken from the photographs.

The photographs may be oriented to this line by placing each photograph over the line and so adjusting it that the line on the

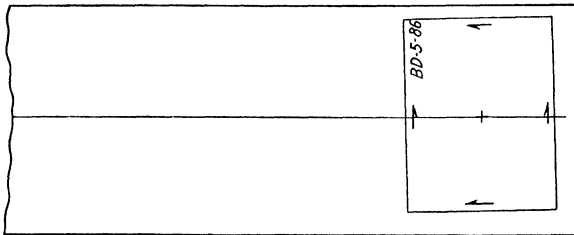

FIG. 193.—Orienting the first print to the flight line.

photograph superimposes the line on the base, at the same time maintaining a detail match between photographs. When these photographs have been adjusted in this manner, they may be fastened permanently to the base, or the detail may be traced off and the photographs filed away.

## CHAPTER XVI

### THE TRIMETROGON SYSTEM OF WORLD CHARTING

At the beginning of the Second World War, the United States had a meager collection of maps and charts. Maps of foreign nations were noticeably scarce and of the entire United States not much more plentiful. For this reason, the production of charts of all kinds for the entire world has shown a remarkable increase since the start of the present conflict.

We had been content to sit back and regard ourselves as sufficient with the regular polyconic projection as our only important source of projection for military mapping. It was immediately realized that this was not accurate enough. We were fighting and planning operations not on a Civil War basis nor yet on the basis of 1917. In that year, it was enough for us to study and make our charts in the same projection and with the same detail as was standard in France.

Now, however, we are involved in a global war; our armies are scattered in India, China, Australia, Africa, England, in fact, on every front; it therefore lies with the proper authorities to revise hurriedly our prosaic system of mapping and think in terms of world charting instead of continental United States charting.

At the present time, those who are responsible for such revision are the members of the map divisions of our armed forces. They have had to investigate all methods of projections and make important decisions regarding the types of projections to be used. In making these decisions, they had to keep in mind the requirements of the air forces rather than the land forces, because war movement of troops in large quantities like divisions, corps, and armies is still much slower and over a smaller territory than the movement of a complete air army.

Methods based on world coverage had to be devised for route planning and tactical movements, world weather charts for our wide-flung air forces, long-range celestial navigation charts with world coverage for our bomber attacks, pilotage charts to be used by the air forces in contact flying, charts of industrial areas and of congested areas, and finally charts for carrying out the destructive bombing raids considered as necessary in modern warfare.

For the time being, at least during this widespread conflict, map-projection experts must now think in terms of the Lambert,

conformal, conic, and Mercator projections for areas between latitudes 80°N. and 80°S. and for some polar projection (stereographic) between latitude 80°N. and the North Pole and latitude 80°S. and the South Pole.

Our idea of scale must also be revised to bring down to convenient size the charts that will be made for coordinated world coverage. Scales ranging from 1:75,000 for target charts to 1:5,000,000 for weather charts are not uncommon.

In line with this need for more coverage on our charts and maps comes the need for a method of obtaining more information from a single flight of a reconnaissance airplane on a photographic mission.

After much experiment and research for a suitable method, the old method of oblique photography was again brought into play, this time, however, using two oblique cameras in conjunction with a vertical camera, and keeping a constant relation between all three cameras. Thus was originated the trimetrogon system of mapping. The method is a mixture of something old and something new and has commonly been called the "illegitimate child of photogrammetry."

The instruments used in this new method of mapping are the rectoblique plotter, the vertical sketchmaster, the oblique sketchmaster, and the Lazy Daisy mechanical triangulation equipment that will be discussed in the following articles.

### RECTOBLIQUE PLOTTER

**Description.**—The rectoblique plotter is an instrument for rectifying the directions of previously established lines on oblique photographs. The rays drawn by means of this instrument represent the true direction in a horizontal plane of a point on the photograph from the plumb point of the photographic set. It consists of a Masonite board  $\frac{1}{8}$  in. thick, about 25 in. wide, and 48 in. long cemented on a piece of  $\frac{3}{8}$ -in. plywood. This board has a sturdy collapsible stand hinged to the bottom, making a convenient tilted table to work on. The metal parts are cold-rolled steel, and the transparent parts are made of Plexiglas. The horizon bar is fitted into the horizon-bar guides so that there will be no binding or looseness. The orientation line, which is scribed on a Plexiglas plate, is parallel to the horizon-bar guide. The photo-arm slide is set on a rigid reinforcing bar. The slide is set perpendicular to the orientation line and the horizon bar. The photo-arm scale (Fig. 194), slides smoothly in the photo-arm slide. It has a lock nut in it that locks the scale in position and still allows the photo arm to slide up and down. For convenience the scale is scribed on both sides. There is a set of indexes for each side of the scale. When the depression

angle is between 21 and 32 deg., the scale is placed in the slide, as shown in Fig. 194, and the upper set of indexes is used. When depression angles greater than 32 deg. occur, the scale is reversed in the slide so that the round end is toward the top, and the lower set of indexes is used. The photo arm has a scribed line as a

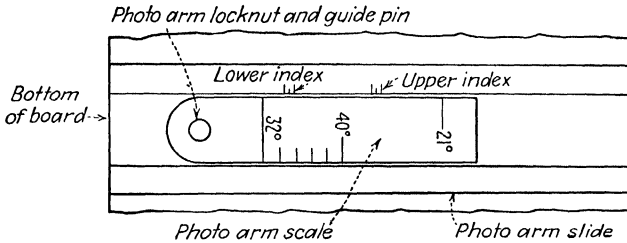

FIG. 194.—The photo-arm scale.

center line, and the lower portion has a slot in it that slides smoothly over the guide pin in the photo-arm scale. The upper end of the photo arm is fastened to the left end of the horizon bar.

The template arm assembly consists of four parts. The template arm connector is fastened to the right end of the horizon bar and has the degrees marked on it from 21 to 40 deg., which correspond

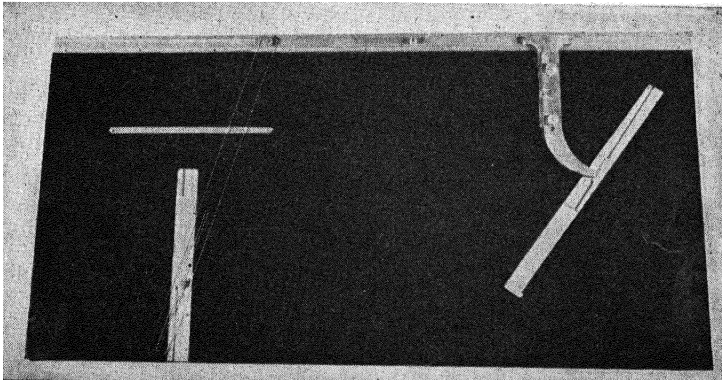

FIG. 195.—The rectoblique plotter.

to the degrees marked on the photo-arm scale. The adjustable connector arm is fastened to the connector arm by means of two thumb nuts. It has a set of indexes marked on it that correspond to the set of indexes on the photo-arm slide. The template arm itself is pivoted on a needle anchored in the board and connected to the adjustable connector by means of a bar 2 in. long and  $\frac{3}{8}$  in.

square. This bar slides freely and smoothly in a groove milled in the template arm. The right edge of the template arm has about a 60-deg. bevel on it. On the horizon bar are a thumb nut and a lock screw. The thumb nut is used for operating the instrument, and the lock screw is used to lock the arms in position so that they will not move.

### Steps in Operating the Abrams Rectoblique Plotting Board

1. *Prepare the Prints.*—Locate all control points and the principal points on the photograph.

2. *Compute the Depression Angle.*—The depression angle is the angle at the camera lens between two imaginary lines extending from the camera to the true horizon and the camera to the principal point

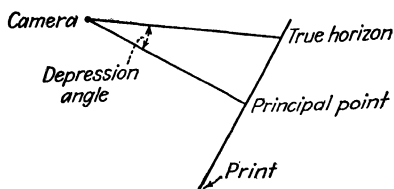

FIG. 196.—Diagram showing the position of the depression angle.

of the oblique print (see Fig. 196). There are several methods of obtaining this angle, depending upon the accuracy desired.

3. *Obtain the Focal Length of the Camera Used, in Inches.*—The board is designed to be used with focal lengths from 6.00 to 6.06 in.

4. *Set the Photo-arm Scale.*—Place the number of degrees of the depression angle obtained in step 2 on the photo-arm scale opposite the focal length obtained in step 3 on the photo-arm guide. There are three index marks in each set. The upper line is used for a 6.00-in. focal length, the lower line for 6.06-in. focal length. Other focal lengths must be interpolated. Notice that there are two sets of indexes (see Fig. 194). The upper indexes are used for depression angles from 21 to 32 deg., the lower set for angles from 32 to 40 deg. Fasten the scale by means of the lock screw.

5. *Set Adjustable Template Arm.*—The same angle and focal length must be set here as were used in step 4. Fasten the arm to the connector by means of the two thumbscrews.

6. *Prepare Paper Template.*—If two opposite oblique photographs are used, the template should be about 20 by 36 in. It is usually made of a sheet of semitransparent paper. It should be of material that will handle without being wrinkled or torn easily. The template should be positively identified with the print. Also the depression

angle and focal length should be recorded in the upper right-hand corner.

7. *Lock Horizon Bar in Place.*—There is a single index line marked on the horizon bar that should coincide with the mark on the horizon bar guide. Line up these two lines, and lock the assembly in place with the lock screw.

8. *Orient Print to Board.*—Slide the print under the photo-arm so that the horizontal fiducial marks line up with the orientation line and the vertical fiducial marks line up with the line on the photo-arm (see Fig. 197). Fasten the print with scotch tape.

9. *Place Template on Board.*—Draw a line down the center of the template the long way, and locate the center of this line. Put one

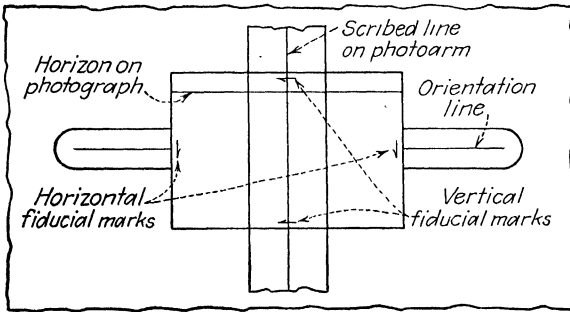

FIG. 197.—Diagram showing how the print is placed on the plotter board.

or two pieces of scotch tape over this point for reinforcement. Remove the template arm from the needle point. Place the template over this needle point, and pierce the template in its center point. Replace the template arm over the needle point and template. Line up the center line of the template with the ruler edge of the template arm. Fasten the template to the board with scotch tape.

The previous procedure is used when two diametrically opposed cameras are used. If only one camera is used, only half the template is necessary. If the cameras used are not 180 deg. apart, the line drawn down the center must be broken at the needle point and laid off the proper number of degrees.

10. *Draw Rays through All Points.*—Unlock the horizon bar and slide the photo-arm index line until it passes over a previously located point on the print. Draw a line along the ruler edge of the template arm with a hard lead pencil (4H or 6H). Label this line in some way so that it can be identified with the point. Repeat this for all points picked on the photograph.

11. *Draw Rays for Opposite Photograph.*—Remove photograph, reverse the template 180 deg., and repeat steps 1 to 10. If the mapping job was not done with opposite cameras, step 11 may be omitted.

12. *Make Paper Templates for All Photographs in the Flight.*—In most cases the amount of overlap is so great that paper templates are not necessary for each adjacent print but can be made for every other photograph.

13. *Fold Up Instrument.*—Tighten the horizon bar and fold the legs.

**Maintenance.**—The parts of the photo-arm assembly can be replaced by removing the lock screw in the photo-arm scale and the



FIG. 198.—The rectoblique plotter in operation.

thumbscrew on the left end of the horizon bar. If any of these parts are broken they can be replaced. The template arm assembly can also be replaced by removing the two screws that hold the parts to the horizon bar. If the template needle is bent or broken, it can be removed and straightened or replaced. It is held in place by a hexagonal nut in the bottom of the board. To remove it, remove the nut and pull the needle up with a pair of pliers. Be sure to pull straight so as not to enlarge the hole. When replacing the needle, be sure to pull it flush with the board.

**Computation of the Depression Angle.**—The depression angle is the angle formed by lines radiating from the camera position, one to the true horizon and one to the principal point of the oblique

photograph. A practical method of obtaining this angle is given in Figs. 199 to 200 and the following discussion.

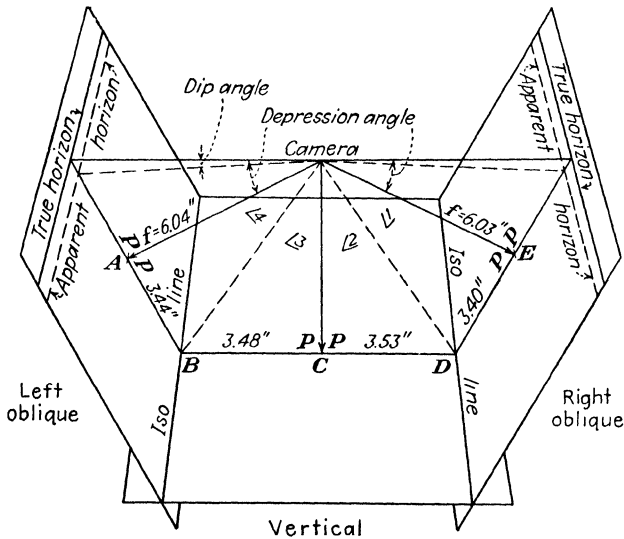

FIG. 199.—Diagram showing the theory of computing the depression angle.

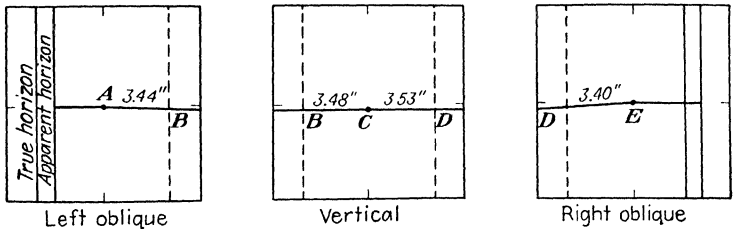

FIG. 200.—Locating points on the isolines so measurements can be made for computing the depression angle.

The steps in the computation are as follows:

1. Change the focal lengths of the three cameras used in taking the two obliques and the vertical from millimeters to inches by the conventional method of dividing the length in millimeters by 25.4.

Example.

- Focal length—right oblique camera—153.0 mm. = 6.03 in.
- Focal length—left oblique camera—153.40 mm. = 6.04 in.
- Focal length—vertical oblique camera—152.70 mm. = 6.01 in.

2. Locate the principal point of all three photographs.



3. Select a point on the principal plane of the oblique print that falls in the overlap between the oblique and the vertical print at about the isoline. Mark this point properly, and transfer it to the vertical print. Repeat this procedure with the opposite oblique (see Fig. 200, points *B* and *D*).

4. Measure the distance from the principal point of the oblique prints to the picked point on the isoline (see Fig. 199, distance *AB*, *DE*).

5. Connect points *B* and *D* on the vertical print. This line may or may not pass through the principal point, depending on the amount of tip there may be.

6. Measure distance *BC* and *CD*. Point *C* may be the principal point if no tilt is present, but if there is tilt, it will be on the line connecting fiducial marks at a point called the *plumb point*.

7. Compute the locking angle in the following manner:

Tangent angle 1	$\frac{ED}{FL_1} = 0.54385$	Angle 1 =	$28^{\circ}32'$	$ED = 3.40$
				$FL_1 = 6.03$
Tangent angle 2	$\frac{CD}{FL_2} = 0.58735$	Angle 2 =	$30^{\circ}26'$	$CD = 3.53$
				$FL_2 = 6.01$
Tangent angle 3	$\frac{BC}{FL_2} = 0.57903$	Angle 3 =	$30^{\circ}04'$	$BC = 3.48$
				$FL_2 = 6.01$
Tangent angle 4	$\frac{AB}{FL_3} = 0.56953$	Angle 4 =	$29^{\circ}40'$	$AB = 3.44$
				$FL_3 = 6.04$
		Locking angle =	$118^{\circ}42'$	
		Subtract from	$179^{\circ}60'$	
			$2) \quad 61^{\circ}18'$	
		Depression angle =	$30^{\circ}39'$	

This angle would be just as practical if used to an even 5 minutes; therefore this could be taken to be  $30^{\circ}40'$ .

#### ABRAMS LAZY DAISY MECHANICAL-TRIANGULATION EQUIPMENT FOR TRIMETROGON

The general purpose of mechanical triangulation has been fully discussed in Chap. XIV, where the method was applied directly to aerial survey consisting of vertical prints only.

To apply the regular Lazy Daisy equipment to trimetrogon, it is necessary to make the addition of 12-, 15-, 18-, and 24-in. slotted arms to the regular sets.

These longer arms are used to incorporate into the regular network of triangles formed from picture points on the vertical prints a new set of triangles formed by radial lines to picture points on the oblique prints.

The paper template drawn up by means of the rectoblique plotter board replaces the photographic template.



FIG. 201.—The "Lazy Daisy" mechanical-triangulator kit.

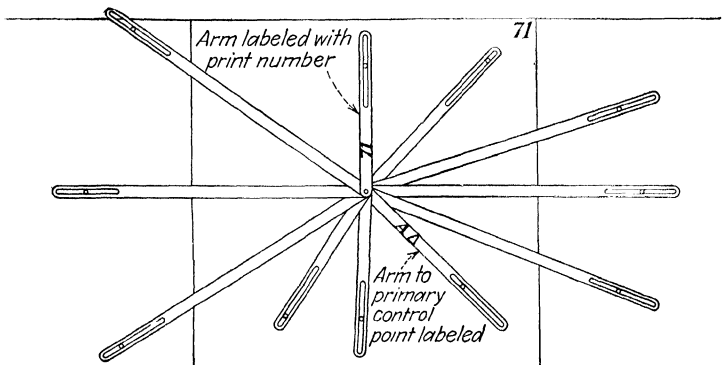

FIG. 202.—An assembled mechanical-triangulator template.

### THE VERTICAL SKETCHMASTER

**Description.**—The vertical sketchmaster is an optical instrument used for transferring desired planimetry from vertical or near-

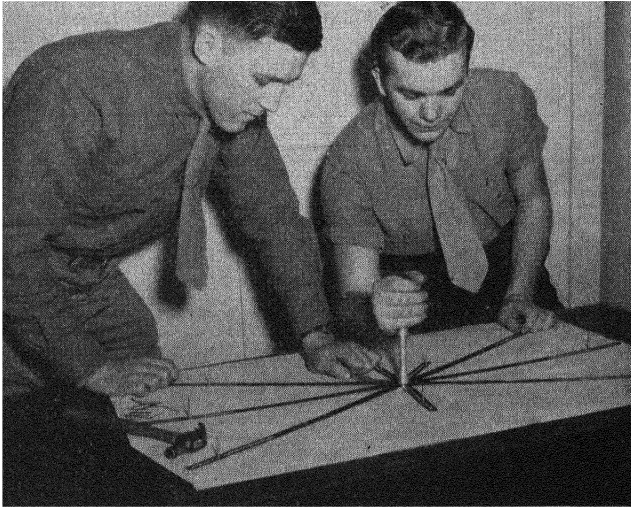

FIG. 203.—Preparing a mechanical triangulator assembly from a paper template.

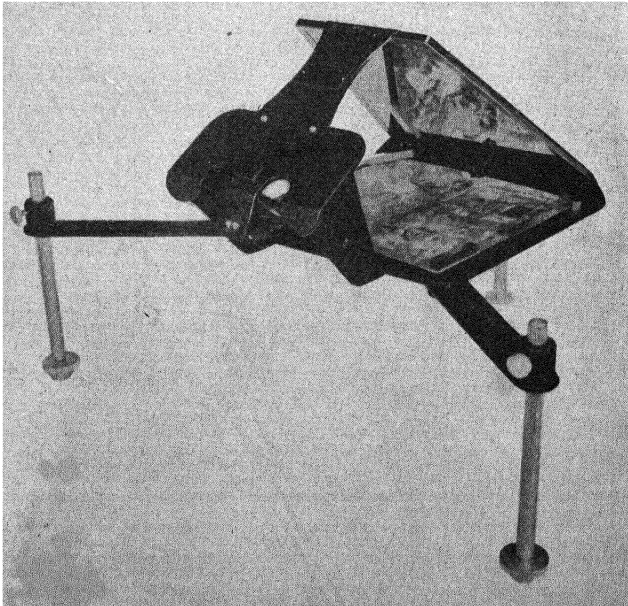

FIG. 204. The vertical sketchmaster.

vertical aerial photographs to a map plane. It is a flexible light-weight unit that can correct for tip and tilt and can be adjusted for various map scales. It is designed to cover a 9- by 9-in. print; however, any larger print can be examined sectionally. By using two instruments and setting them as a stereoscope, the planimetry can be traced to the map plane from the spatial model. This is extremely valuable for tracing in streams and ridges.

The base plate and frame are made of sturdy 16 gauge metal. The base plate is approximately 10 by 10 in. and is supported by three leg assemblies about 8 in. long. The instrument adjusts for tip, tilt, relief, and scale by means of these leg assemblies. The entire instrument can slide up and down on the legs to adjust for the approximate scale while final adjustments are made with the adjusting nut screwed into the leg tube. This adjusting nut has a polished spherical base that permits it to be moved easily.

As the print is lying on the base, the image is reflected toward the eye by means of a large front-surface mirror. The reflecting surface is made of chrome aluminum. A front-surface mirror is used instead of the conventional back surface, in order to avoid refraction due to thickness of the glass. Extreme care should be taken with this mirror, for it can easily be scratched and tarnished. Never touch the front surface with the hands. If it needs dusting, do it very carefully with a clean lens tissue. The light from this surface is reflected into the eye by means of the small half-silvered mirror located under the diaphragm. This small mirror has a sturdy half film and can stand light cleaning without damage. It reflects the light from the print into the eye and transmits the light from the map plane to the eye. Directly under the half-silvered mirror is a meniscus lens firmly held in a lens holder. The purpose of the lens is to focus the map plane upon the eye. The diameter is  $1\frac{1}{4}$  in. The lens can be removed from the holder. It has a power of 3.25 diopters (the reciprocal of the focal length in meters). This size of lens is best suited for reducing the scale 47 to 55 per cent or a scale ratio range of 0.47 to 0.55.

Other lenses can be used for other ratio ranges. The following lenses are best suited for the various ratio ranges.

Lens	Ratio Range
None	0.86-1.14
1 diopter	0.69-0.86
2 diopters	0.57-0.69
3 diopters	0.49-0.57
3.25 diopters	0.47-0.55
4 diopters	0.42-0.49
5 diopters	0.38-0.42

Each instrument is provided with six special magnets for holding the prints in place. Care must be taken to avoid dropping or marring these, for marring will reduce their holding power. When the magnets are returned to their special compartment in the case, they should be lined up positive to negative so that they will retain their magnetism. The positive end of each magnet is marked by a red dot.

The carrying case has been designed to fit properly. Places have been provided for the magnets and for extra lenses. When the instrument is not in use, it should be kept locked in the case.

**Operation.** 1. *Remove Instrument from Case.*—The instrument is held in the case by means of four plywood wings. Turn these buttons until they are free of the base of the instrument. Pick up the instrument by the base at both ends. *Do not touch the front full-surfaced mirror.* Remove the magnets and lenses to be used, and close the case cover.

2. *Set Up Sketchmaster.*—Swing the front leg supports around until they lock under the wing nut under the base. Tighten the wing nuts firmly.

Loosen the thumbscrew holding the legs. Pull out the leg assembly about 6 in., and fasten it at the number 2 notch mark. There is a guide line above each notch. If the top of the bushing on the leg support is brought to this guide line, the thumbscrew will center in the notch.

3. *Place Proper Lens in Holder.*—The proper lens can be chosen by referring to the lens and ratio range chart printed previously. The ratio range is the ratio of the map scale to the print scale.

4. *Place Instrument to the Proper Notch on the Legs.*—This can be done by the following table:

	Ratio Range
Top notch . . . . .	0.75–1.14
Middle notch . . . . .	0.45–0.75
Lower notch . . . . .	0.35–0.45

5. *Place Print in Position.*—The print is placed on the center of the base plate of the instrument and held there by placing the magnet along the edges. Be sure the print is smooth.

6. *Orient Print to Map Plane.*—The map plane should have pass points and other control points located on it by means of the mechanical triangulator. Move the instrument until the center of the print is over the proper control point of the map plane. Adjust the print that has the control points plotted on it to the respective control points on the map plane by turning the adjusting nut of the leg

assemblies. It is wise to become familiar with this adjustment before putting it over the map plane.

7. *Trace Planimetry on the Map Plane.*—The instrument is now in the correct position, and the detail can be sketched in directly. Be sure that the head is held in one position; otherwise the parallax will cause an error in the map. It is helpful to have a stereoscope to identify detail that cannot be seen clearly with the sketchmaster. The stereoscope will also help a great deal when there is relief.

8. *Complete Tracing of Detail on Map Plane.*—By putting on successive photographs of the entire area flown and moving the

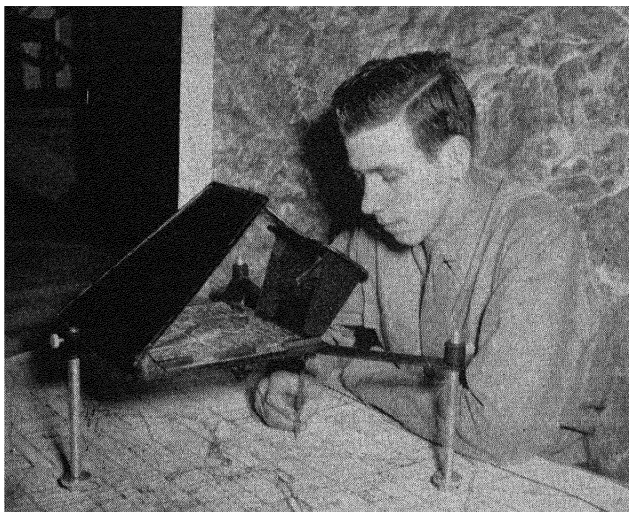

FIG. 205.—Sketching with the vertical sketchmaster.

instrument along the map plane, the map can be completed. Remember to use the center portion of each print.

9. *Replace Instrument in Case.*—*a.* Remove the lens and magnets and put them in the case. Be sure that the magnets are lined up properly. Alternate the red dots.

*b.* Screw the adjusting nut firmly into the legs.

*c.* Loosen the thumb nuts and lower the instrument to the top of the adjusting nut.

*d.* Tighten these thumb nuts.

*e.* Loosen the wing nuts under the base that are holding the front leg supports.

*f.* Swing back the front legs and supports.

*g.* Cover the mirrors with lens tissue if possible to prevent dirt collecting on them.



FIG. 206.—A planimetric map

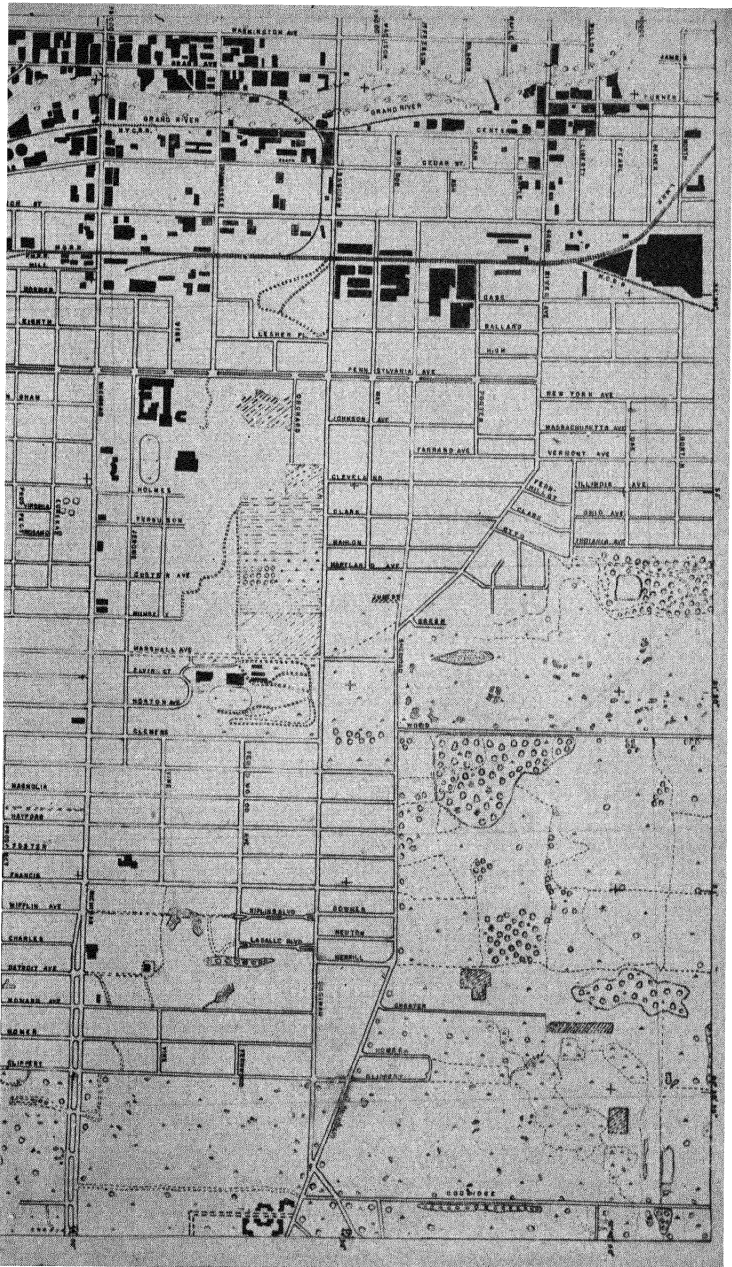

compiled with a vertical sketchmaster.



- h. Lift up the instrument by the base and place it in the case.
- i. Swing the wings back over the base and tighten them.
- j. Close and lock the case.

**Maintenance.**—If it is given proper care, there should be no need of replacing or repairing any part of this instrument. However, if parts are broken or damaged, they can be replaced. The two mirrors are the most likely to be broken or badly scratched.

*Replacing Large Mirror.*—Remove the two screws holding the brace (the part with the name plate on it). Remove the two screws holding the stainless-steel molding of the mirror. These screws are in the back portion of the instrument. Put the new mirror in place, and replace parts and screws.

*Replacing Half-silvered Mirror.*—Remove the two screws holding the small bar below the mirror. Slip the new mirror into the holder. Replace the retaining bar and screws.

When any of the optical parts are replaced, be sure that the angular relationships are not changed. The large mirror is 39 deg. from the base. The small mirror is parallel to the large one. The small mirror can be adjusted. The lens is parallel to the base.

#### *Things to Remember*

1. Keep the hands off any mirror surface.
2. Clean the mirrors with a clean lens cloth or tissue.
3. Be sure that the three adjusting screws in the legs are screwed tight against the leg rods when they are returned to the case.
4. Have all four wings over the frame of the instrument when it is in the case.
5. Close and lock the case when it is not in use.

### THE OBLIQUE SKETCHMASTER

**Description.**—The oblique sketchmaster is an optical instrument used for transferring planimetry from an oblique photograph to a horizontal map plane. Before the detail of the photograph can be traced to the map plane, a network of points must have been plotted on the photographs; and a corresponding network of points, corrected to the horizontal, must have been established on the map plane. The correction of points from the oblique to the horizontal can be accomplished by the use of the rectoblique plotter and the mechanical triangulator.

The main parts of the instrument are shown assembled in Fig. 207. The three elevation screws support the frame of the instrument. When these elevation screws are adjusted, the instrument will rectify the print image for tip, tilt, and scale. The hood holds the

optical system and print. It is secured to the frame by means of a hinge at the front of the instrument. The hood is leveled to the map plane by means of the two leveling screws. These leveling screws correct for varying depression angles and scale. The photograph is inserted in a Plexiglas frame under the cover that forms the rear part of the hood. The cover is hinged and has a clip fastener that makes it easy to insert and replace the prints. Under the top portion of the hood is a large front-surfaced mirror for reflecting the light from the photograph toward the half-silvered mirror. This front-surfaced mirror must not be touched or handled, for it will tarnish and scratch easily.

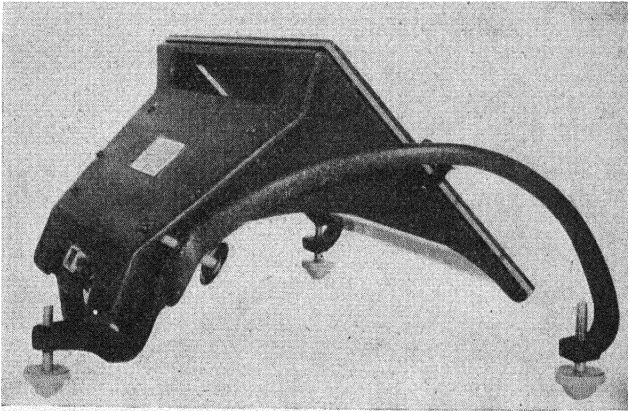

FIG. 207.—The oblique sketchmaster.

The half-silvered mirror is located under the diaphragm and reflects light into the eye from the large mirror. The light from the map plane is transmitted through the small mirror into the eye. Thus the light from the two sources, the print and the map plane, enters the eye, and the operator sees the two images as one superimposed upon the other. Because of the accurately constructed angles between this part of the optical system, the oblique photograph appears as a vertical print on the horizontal map plane. When properly adjusted, the oblique is rectified in scale and direction. To understand this more fully, examine Fig. 208A and B. If a grid similar to A is placed in the print frame of the instrument, the operator will see a grid similar to B on a map plane.

The carrying case is made of plywood and made to hold the instrument firmly. When the instrument is not in use, it should be fastened in the case, and the case should be locked.

**Operation.** 1. *Remove Instrument from Case.*—The instrument is held in place by three plywood wings. The wings are held in place by locking screws. Unscrew the locking screws, and rotate the wings free from the leg screws of the instrument. Lift the instrument from the case, and close the case.

2. *Dust Off Mirrors.*—Use a lens tissue and be careful not to touch the surface with the hands. Avoid scratching the surface.

3. *Place Instrument on Map Plane.*—The map plane must have the proper network of points located on it. Since the instrument must be almost level with the operator's head, it is good practice to have the map plane on a high plane surface. A high light table is excellent.

4. *Place the Photograph in Instrument.*—*a.* The pass points and other control points must be located on the photograph before it is placed in the instrument.

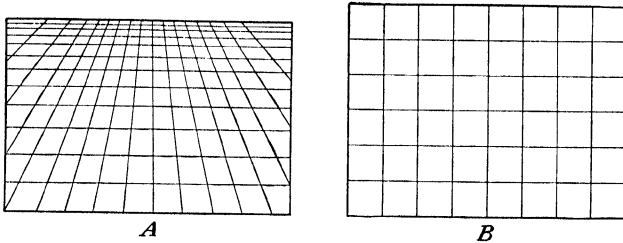

FIG. 208.—A converging and horizontal line plot.

*b.* Open the cover on the back of instrument.

*c.* Place the photograph in its holder so that its horizon line will fall about  $\frac{1}{4}$  in. below the top border. Exceptions to this distance may occur; but, with the print in this position, accurate work can be accomplished.

*d.* Close the back cover.

5. *Adjust a Light to Fit Needs.*—There is a light slot in the hood of the instrument to facilitate the lighting of the photographs.

6. *Orient Print to Map Scale.*—*a.* Move the instrument until it is over the points on the map scale that correspond to the points on the print.

*b.* Adjust the instrument, by using elevation and leveling screws, so that the points on the photograph appear to coincide with the corresponding points on the map plane. Scale changes are made by using the leveling screws and the front leg elevation screw. Tilt adjustments are made by using the same screws. The tip adjustment is the two elevation screws on the rear legs. When there is excessive relief, all the points will not coincide, owing to relief

displacement. In such cases, adjust as many points as possible, sketch in the area, and then change the adjustment until other points are in adjustment. In a normal position for about 50 per cent reduction in scale, the distance from the bottom of the aperture opening to the map plane should be about  $2\frac{3}{4}$  to 3 in., and the rear bottom edge of the hood should be about 2 in. above the map plane.

7. *Trace Planimetry on Map Plane.*—The instrument is now in the correct position to sketch the planimetry onto the map plane. Be sure to hold the head in one position; otherwise there may be an error caused by parallax.

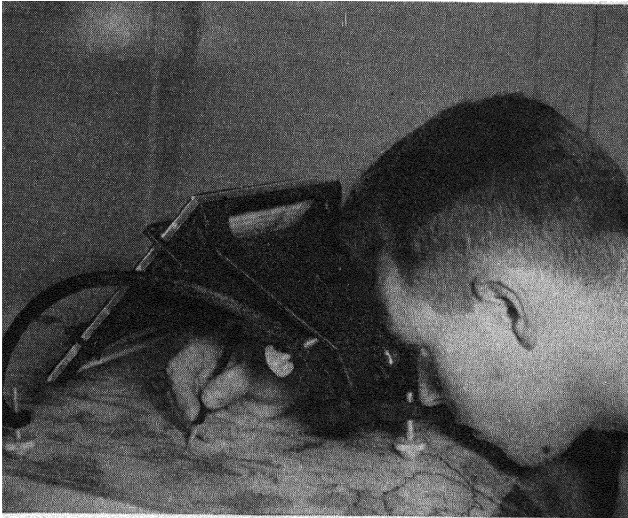

FIG. 209.—The oblique sketchmaster in operation.

8. *Complete Tracing of Map.*—By putting in successive prints of the flight strip, the entire area covered by the photographs can be traced.

9. *Replace Instrument in the Case.*—*a.* Turn the elevation screws until they are tight against the legs.

*b.* Lower the hood by turning the leveling screws until the hood rests against the leg frame.

*c.* Cover the mirrors with lens tissue.

*d.* Place the instrument in the case so that the three elevation screws rest in the holes provided for them.

*e.* Rotate wings over the instrument and tighten lock screws.

*f.* Close and lock the cover.

**Maintenance.**—With proper care, there should be no need of replacing or repairing any part of this instrument. In case of breakage or damage, the parts can be replaced. The two mirrors are the most likely to be broken or scratched. To remove the large mirror, it is necessary to remove the four screws that hold the mirror brackets.

1. Remove the two screws in either side of the hood. They are near the point at which the hood rests on the leveling screws. This releases the two angles holding the mirror.

2. Remove the two screws that are above and to either side of the name plate.

3. Hold the new mirror in place, using a clean lens cloth or tissue.

4. Replace screws and brackets. The small mirror can be replaced by removing the two screws that fasten one of the brackets that holds the mirror. This allows the small mirror to slip in or out sideways. Be sure that both mirrors are tight. The large mirror must be placed so that the beveled edge of the mirror is toward the metal of the hood.

#### *Things to Remember*

1. Keep the hands off any mirror surface.
2. Clean the mirrors with a clean lens cloth or tissue.
3. Do not rub mirror surfaces.
4. Be sure all adjusting screws are screwed up when placing them in the case.
5. Be sure the hood of the instrument is caught under the beveled edge in the case.
6. Fasten the wings securely in place.
7. Lock the case whenever it is not in use.

#### HOW THE INSTRUMENTS ARE USED

1. Locate all required points on photographs: (a) principal points, (b) control points, and (c) secondary control points.

2. Compute the depression angle.

3. Construct a paper template using the *rectoblique plotter* and the two oblique photographs. A template must be made for each trimetrogon set used. Usually every other oblique picture is used, but every vertical must be used. Draw rays to all control points, and label each ray.

4. Extend the control over the complete flight, using the *mechanical triangulator*. The principal point of the vertical photograph is centered on the center of the paper template constructed in step 3. The print is oriented to the template by means of the control points.

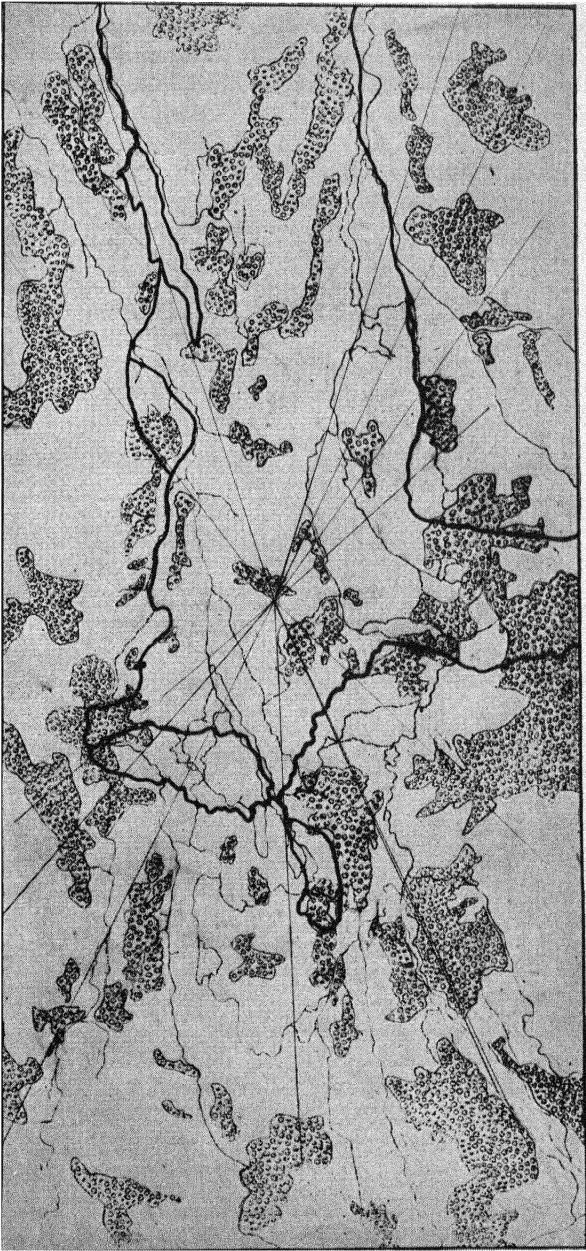

FIG. 210.—A complete planimetric sketch made from a set of trimetrogon prints.

This rectifies the errors of the photograph and establishes the true positions of the points marked in step 1 to the desired scale.

5. Transfer all the points located in step 4 to a map sheet.
6. Trace the planimetry from the vertical print to the map sheet by means of the vertical sketchmaster.
7. Trace planimetry from the oblique prints to the map sheet by means of the oblique sketchmaster.

## GLOSSARY OF PHOTOGRAMMETRIC EXPRESSIONS<sup>1</sup>

- aberration.** Refers to physical defects of lens. See astigmatism, chromatic aberration, coma, curvature of field, and distortion.
- absolute orientation.** Properly fixing or placing the relatively oriented prints to conform to the plotted scale and position of the ground coordinates. See exterior orientation, relative orientation.
- absolute humidity.** The weight of water vapor in a certain volume of air, expressed as grains per cubic foot. See humidity.
- absolute stereoscopic parallax.** The algebraic difference, parallel to the air base, of the distances of two images from their principal points. See parallax.
- accelerator.** A chemical that hastens the reaction of another chemical.
- accuracy.** Degree of conformity with a standard.
- acetate.** A film like celluloid, with one side abraded to afford a drawing surface.
- achromatic lens.** A lens that has been ground to bring the red and green rays to the same focus.
- adhesive.** A glue or cement used for sticking one surface to another.
- adjacent.** The side adjoining an acute angle of a right triangle.
- aerial camera.** One built especially for airplane use. See camera.
- aerial mosaic.** Composite pictures of two or more aerial prints. See mosaic.
- aerial photogrammetry.** Photogrammetry that uses aerial photographs. See photogrammetry.
- aerial photograph.** One taken from an aircraft.
- aerial photography.** The art of taking and processing pictures from an aircraft.
- aerial survey.** A survey made by using aerial photographs. See survey.
- aeronautical chart.** One compiled for the particular benefit of the aviator.
- air base.** A line between two stations, referred to as the air distance from the principal point of one photograph to that of another.
- air coordinates.** Position of an image point on overlapping photographs in reference to the air base. See coordinates.
- air speed.** Rate of movement of an aircraft through the air.
- alidade.** An instrument used in surveying with a plane table for making topographic maps.
- altimeter.** An instrument for measuring height above sea level.

<sup>1</sup> This list of terms has been compiled and defined to apply to expressions used in this text and to the science of photogrammetry. It has been necessary in several cases to use approved definitions that have been prepared and issued by the Committee on Nomenclature of the American Society of Photogrammetry.



- altitude.** Indicated height above sea level, usually expressed in feet.
- Amici prism.** A prism that deviates light rays 90 deg. and inverts the image.
- anaglyph.** A picture printed in two colors and offset to give a relief effect when viewed by glasses with lenses of similar colors.
- analemma.** Greek word for sundial, a graduated scale used with a globe for measuring the sun's declination.
- anastigmatic lens.** A lens corrected for curvature of field.
- aneroid barometer.** An instrument used for measuring atmospheric pressure and determining elevations. See barometer.
- angle.** A figure formed by two lines coming together at a point. See deflection angle, interior angle.
- angle of incidence.** The angle that light rays make from the normal.
- angle of reflection.** The angle that light rays make when reflected.
- angle of refraction.** The angle that light rays make when bent by some medium.
- angstrom unit.** A standard measurement of light waves.
- angular calibration.** The interior orientation of the plate perpendiculars to a common origin of direction, in cameras with several lens.
- aperture stop.** Different degrees of opening in a lens from the smallest to the largest.
- aplanatic lens.** A lens corrected for chromatic and spherical defects.
- apochromatic lens.** A lens corrected for three colors.
- apparent horizon.** The visible, or apparent, junction of the sky and earth.
- astigmatism.** A defect in a lens that affects the sharpness of an image caused by light rays coming to a focus in different planes. See aberration.
- astronomic station.** A point from which the heavenly bodies are observed for the purpose of determining longitude, latitude, or azimuth.
- asymmetrical lens.** A lens with front and rear elements unlike.
- atlas sheet.** A reproduction made to a certain scale as adjoining sheets, to be bound into book form.
- axis.** A line passing through an object around which the parts are symmetrically arranged and may be revolved. See optical axis.
- axis of tilt.** A line through the perspective center perpendicular to the principal plane. See principal plane.
- azimuth.** An arc of the horizon used to determine certain measurements. See grid azimuth, magnetic azimuth.
- background.** Part of a photographic picture, usually in the direction of the horizon from the camera.
- backsight.** A surveying term applied to sighting an instrument on a known point, for determining the elevation or direction of an unknown.
- bar scale.** A graphic scale representing distances on a map.
- barometer.** An instrument for measuring atmospheric pressure. See aneroid barometer.
- barometric elevation.** An elevation of a point made by a barometer.
- basal coplane.** Two photographs in a common plane parallel to the air base. See coplanar.
- basal orientation.** Determining the position of both ends of an air base by ground coordinates.

- base direction.** Direction of a vertical plane expressed as a bearing or azimuth.
- base line.** The line between the principal point and the transferred principal point of an aerial photograph.
- base map.** A sheet with certain positive data to which other information is applied. See map.
- base tilt.** Inclination of the air base to the horizon.
- beam of light.** A group of bundles of rays. See ray of light.
- beam compass.** A bar with two adjustable points used for scribing or measuring distances.
- between-the-lens shutter.** A mechanical device to intercept the passage of light between the lens units. See shutter.
- binocular vision.** Seeing an object by using both eyes. See stereoscopy.
- bridging.** The adjustment of photogrammetric surveys between ground control.
- cadastral map.** A map indicating land boundaries for the purpose of determining titles.
- calibrated focal length.** The perpendicular distance from the rear node to the focal plane when the camera is set to focus at infinity. See equivalent focal length.
- calibration.** A certain specific measurement in a device which has been made to conform to a given standard.
- calibration constants.** Results obtained by calibration that describe the principal point, fiducial marks, and focal length of the lens-camera unit.
- calibration data.** Records of calibration measurements.
- calibration template.** A glass, metal, or other material used to make calibrated measurements.
- camera.** A device to record a reflected light on a sensitized surface. See aerial camera, copying camera, ground camera, multiple-lens camera, precision camera, single-lens camera, and surveying camera.
- camera axis.** The photograph perpendicular.
- camera mount.** A circular frame installed in the airplane to hold the camera in position.
- camera station.** A point occupied by the lens at instant of exposure. The air station.
- camouflage.** Concealing or hiding objects so that they are unnoticeable.
- cant and torque.** The relation of a stereo-pair as to tilt and orientation in regard to the earth's surface. See differential torque.
- cantilever strip.** A term used in foreign countries to denote forward overlap from a controlled to an uncontrolled area.
- cartographer.** One who makes charts or maps.
- cartographic.** Pertaining to making or drawing charts or maps.
- cartography.** The art of expressing, by means of lines, the surface of the earth on maps.
- celluloid-template method.** A hand-template triangulation made on celluloid by scribing lines through radial points and the radial center. See radial line control, or triangulation.
- characteristic.** In logarithms, that part called the whole number.
- chromatic aberration.** A defect in a lens that affects the sharpness of an image caused by different colored light rays coming to a focus in different planes. See aberration.
- clinometer.** An instrument used to measure the degree of a slope.

- coated lens.** One coated with a thin transparent film to reduce light loss due to reflection.
- cockpit.** The interior of an aircraft or aircraft cabin.
- collimate.** Adjusting the fiducial marks of a camera to determine the principal point.
- color layers.** Layers of color, each placed separately to indicate horizontal places of different elevations. See *hypsography*.
- coma.** Defects of a lens that appear as blurred spots, pear- or comet-shaped, not circular. See *aberration*.
- common scale strip.** A term used in foreign countries to determine a standard scale for compiling purposes, to which adjoining strips are controlled.
- compass.** An instrument used to determine direction.
- compass rose.** An artistic method of indicating direction on a map.
- complementary colors.** Two colors that, when projected or added together, produce a white color.
- composite photograph.** Two or more photographs taken at the same time by a multiple-lens camera and joined together.
- condenser.** An optical instrument to collect light rays into one beam.
- conic.** In the shape of a cone.
- conjugate distance.** The ratio of distance between the object and lens and the lens and image.
- conjugate image point.** The same object point on two or more overlapping photographs.
- conjugate image rays.** Rays connecting image points to a perspective center.
- constant tilt.** The condition when photographs in a flight strip are tilted in nearly the same direction.
- construction line.** A line drawn on a base sheet for the purpose of giving proper orientation of other lines.
- contact print.** A photograph made by direct contact with the negative.
- contour.** An imaginary line on the ground connecting points of equal elevation. See *hypsography*.
- contour interval.** The interval between contours.
- contour line.** A line representing a contour drawn on a map.
- contour map.** One that shows the relief of the terrain by contour lines. See *map*.
- control.** Various systems of accurate measurements. See *geodetic control*, *ground control*, *horizontal control*, *photogrammetric control*, and *vertical control*.
- control point.** A point selected and identified on a photograph in a horizontal or vertical control system.
- control strip.** A strip from which data are obtained to serve in assembling other strips.
- controlled mosaic.** One in which many points of detail have a known location. See *mosaic*.
- convergence.** Tendency to one point.
- convertible lens.** One containing two or more elements that can be used individually.
- coordinates.** A designated position obtained by linear or angular measurements. See *air coordinates*, *geographic coordinates*, *grid coordinates*, *photographic coordinates*, *plane or rectangular coordinates*, and *polar coordinates*.

- coplanar.** Lying in the same plane. See basal coplane, horizontal coplanar.
- copying camera.** One made to reproduce to a larger or smaller size. See camera.
- correction graph.** A graph constructed on photographs to correct for the error inherent in the spatial model.
- correspondence.** The condition when two corresponding images on a pair of photographs lie in the same plane.
- coscant.** A trigonometric function, the secant of the complement of an angle.
- cosine.** A trigonometric function, the sine of the complement of an angle.
- cotangent.** A trigonometric function, the tangent of the complement of an angle.
- course.** The direction in which an aviator pilots a plane in relation to a map.
- crab.** The angle that the airplane or camera makes by being twisted from the true line of flight.
- cross hair.** Two intersecting fine lines in the telescope of a surveying instrument.
- culture.** Man-made features of the terrain, such as roads, bridges, and buildings.
- curvature of earth.** The arc that the earth makes from a plane surface.
- curvature of field.** A defect of a lens that causes the image to be dish-shaped or curved. See aberration.
- datum.** A theoretical mean level at or above sea level.
- datum plane.** A certain mean level at or above sea level.
- declination.** The arc or angle that a line makes with the geographic meridian. See grid declination, magnetic declination.
- deflection angle.** The angle between a new line and a line made by extending one side of a traverse. See angle.
- delineation.** Accurately representing on a map the physical and cultural features of the earth by lines and symbols.
- departure.** A distance due east or west from a point of origin, measured on the *X* axis.
- depression angle.** The angle made between the camera axis and the true horizon on an oblique photograph.
- depth curves.** Contour lines representing different depths of water. See hypsography.
- details.** Representing minute and small items on a map to furnish greater information.
- developers.** Chemicals employed in a formula to bring out the latent image of a print or negative.
- developing outfit.** A complete mechanical device used to process a roll of film.
- diapositive.** A small positive photographic plate used in a stereoplotting instrument.
- dichromatic.** Having two fundamental colors.
- differential leveling.** Using a surveying instrument for determining the elevation of an unknown point from a known point.
- differential shrinkage.** The difference in contraction of material between the long grain and the cross grain.

- differential torque.** The difference in torque between the left- and right-hand photographs. See cant and torque.
- diffraction.** Light waves bending around the edges of opaque objects.
- dimensional.** A measure in a single line of length, width, height, thickness, or circumference.
- dioptr.** A unit of measurement in power lenses.
- dip angle.** The angle formed between the true horizon and the apparent horizon on an oblique photograph.
- direct radial triangulation.** To plot in flight trips without ground control. See radial line control, or triangulation.
- direction of tilt.** The direction of the principal plane of a photograph.
- dispersion.** A characteristic of glass in spreading light rays to form a spectral band.
- displacement.** The difference between the correct position of a point or object and its later or apparent position.
- distant line.** The line representing the apparent horizon on oblique photographs.
- distortion.** A defect of a lens that causes the objects at different distances from the axis to be out of position owing to different magnifications. See aberration.
- dove prism.** A prism that reverses the image but does not deviate or displace the beam.
- drift.** Skewing, varying from the horizontal flight line owing to wind pressure.
- dummies.** Likenesses of objects prepared to deceive the observer, as in camouflage.
- easel.** A board or frame used to hold the unexposed print during exposure.
- ecliptic.** The great circle of the celestial sphere that is the apparent path of the sun.
- end lap.** Overlap of two photographs in line of flight.
- enlargement.** A reproduction made from a negative to a larger size.
- epipoles.** Places or points on two perspective photographs where they are cut by the air base line. If both are truly vertical, these points extend for an infinite distance from the base line.
- equator.** An imaginary line around the earth midway between the two poles.
- equator trace.** The trace on a photograph of an equatorial plane passing through the perspective center of the photograph.
- equivalent focal length.** The distance from the rear node of the lens to the focal plane when the camera is set to focus at infinity. See calibrated focal length.
- exposure.** The act of exposing a sensitized surface.
- exterior orientation.** A set of quantities that fix the angular position of the photograph and the correct position of the camera station. See absolute orientation, relative orientation.
- eye base.** The established distance between the centers of the eyes of an individual.
- eyepiece.** That end of a telescope placed nearest the eye.
- fiducial axis.** The lines drawn on a photograph from the opposite fiducial marks.
- fiducial marks.** Rigidly fixed marks on the side of the focal plane of the camera that form images in the center of all sides of the negative.

- field inspection.** To compare photographs with the actual ground conditions.
- film-drying outfit.** Equipment used for drying film.
- film-numbering table.** A table used for numbering and inspection of aerial films.
- filter.** A material used to absorb certain light rays before they enter the lens.
- five-lens camera.** One having five lenses mounted so that four take obliques and one takes a vertical, exposing five negatives of the same size at one time.
- fixing bath.** A chemical solution used to stop the action of the developer and to make the unexposed and undeveloped silver in film or paper soluble.
- flight altitude.** Height above datum at which the flight occurred.
- flight ceiling.** The maximum altitude at which an airplane will perform economically.
- flight line.** The horizontal direction that the airplane should fly in making a strip of photographs. On a pair of photographs, it is the line drawn from the principal point of one photograph through the transferred principal point of the second photograph.
- flight map.** A line map prepared with flight lines.
- floating mark or dot.** A small mark or dot employed in a stereoplottting instrument to be used for tracing contours or planimetry from a spatial model.
- focal length.** See equivalent focal length.
- focal plane.** The plane at the back of the camera where the image is brought into focus.
- focal-plane shutter.** A curtain type of shutter located just in front of the focal plane, with various widths of slots and a spring tension to give different exposures. See shutter.
- focus.** That point at which the rays of light converge to form an image.
- foresight.** A point picked ahead of a survey party for the purpose of determining its location in respect to the survey.
- form lines.** Contour lines on a map that show configuration of the earth. They do not have a definite elevation. See hypsography.
- forward lap.** Overlap made between two successive photographs in the line of flight. See overlap.
- front nodal point.** The first, or incident, nodal point. See nodal point.
- gap.** Where aerial photographs fail to give complete coverage.
- geodesy.** The science that describes the size and figure of the earth by direct measurements.
- geodetic control.** That which applies to the size and shape of the earth. See control.
- geodetic survey.** A survey that takes into account the size and shape of the earth.
- geographic coordinates.** Absolute position of a point in respect to its position on the earth's surface, designated by latitude and longitude. See coordinates.
- geographic lines.** Lines made on a globe or map, indicated as latitude or longitude.
- geoid.** A plane surface such as that at sea level that extends continuously through all the continents. See ground plane, horizontal

control datum, horizontal plane, level surface, local datum, map plane, North American datum of 1927, reference spheroid, and vertical control datum.

**geology.** A science that treats of the history and formation of the earth.

**geometry.** The science that deals with the measurements of such figures as solids, surfaces, lines, and angles.

**goniometer.** An instrument for measuring angles. See photogoniometer.

**grid.** See map grid.

**grid azimuth.** The measurement of an angle between a line and grid north. See azimuth.

**grid coordinates.** Points based on a mathematically adjusted map in relation to latitude and longitude. See coordinates.

**grid declination.** The arc or angle that a grid line makes with the geographic meridian. See declination.

**grid method.** A method of superimposing a map grid over a photograph for plotting the detail.

**ground camera.** Various camera constructions suitable for ground use only. See camera.

**ground control.** That which is obtained by surveys, also called primary control. See control.

**ground control point.** See control point.

**ground nadir.** A point on the ground directly beneath the center of the lens. See nadir.

**ground parallel.** The intersection of the plane of the photograph and the ground reference plane. See principal plane.

**ground photogrammetry.** Using ground photographs. See photogrammetry.

**ground photograph.** A photograph taken on the ground.

**ground plane.** The horizontal plane passing through the ground nadir of a camera station. See geoid.

**ground plumb point.** A synonym for ground nadir.

**ground speed.** The rate of travel of an aircraft in relation to the ground.

**ground survey.** A survey made by ground methods utilizing surveying instruments. See survey.

**gyroscope.** An instrument used to stabilize an aircraft in a horizontal position when in flight.

**hachures.** Short straight lines running parallel with the slope to show relief on a map. See-hypsography.

**hasty map.** An overlay made directly from the photographs by using symbols.

**haze.** The condition of the atmosphere when not fully transparent owing to the presence of foreign matter.

**heading.** The course of an aircraft with drift correction applied.

**high oblique photograph.** A photograph taken when the axis of the camera is held at a plane more horizontal than vertical.

**homologues.** Similar points or lines on two or more photographs.

**horizon.** The apparent or visible junction of sky and earth. See terrestrial horizon, true horizon.

**horizon photograph.** An oblique photograph taken simultaneously with a vertical photograph so that tilt can be determined in the camera at the instant of exposure.

- horizon trace.** An imaginary line on a photograph that represents the true horizon. See principal plane.
- horizontal.** Parallel to the horizon.
- horizontal control.** That which is parallel to the earth's surface. See control.
- horizontal control datum.** The position of a spheroid of reference assigned to the horizontal control of an area and defined by various types of survey measurements. See geoid.
- horizontal coplanar.** Lying in the same horizontal plane.
- horizontal photograph.** A photograph taken with the camera axis horizontal.
- horizontal plane.** A plane that is perpendicular to the direction of gravity at one point only. See geoid.
- humidity.** Degree of moisture in the air. See absolute humidity, relative humidity.
- hydrographic map.** A map made to show water and its adjoining land as its special features.
- hypotenuse.** The side opposite the right angle of a triangle.
- hypograph.** An instrument used to compute elevations from vertical angles and horizontal distances.
- hypsography.** That part of a map which shows relief. See color layers, contour, depth curves, form lines, and hachures.
- hypsometry.** A general term denoting elevations above sea level.
- index mark.** The position occupied by a stereoploting instrument and used as a reference mark for examining the model.
- interior angle.** The inside angle between any two sides of a closed traverse. See angle.
- interior and exterior center.** Refers to the front and rear nodal points of the camera lens. See perspective center.
- interior orientation.** To establish the principal point in respect to its proper distance from the fiducial marks.
- interior perspective center.** The point of origin or the determination of perspective rays inside an object. See perspective center.
- interpolation.** Determining intermediate values, all of which are equal, between two fixed points.
- interpupillary distance.** Distance between the pupils of the eyes.
- interval.** A distance, space, or gap between objects.
- intervalometer.** An instrument devised to control the interval between exposures.
- iris diaphragm.** The stop or aperture in a lens that makes it possible to control the amount of light entering.
- isocenter.** The common center of a photograph from which the displacement of images can be plotted. It is found by bisecting the angle of a plumb point and the principal point found on a photograph.
- isogonic.** Indicating equality of declination of the magnetic needle.
- isogonic lines.** Lines on a map connecting points of equal declination.
- isometric parallel.** A line perpendicular to the optical axis at the principal point.
- isoradial.** A radial line from the isocenter. See radial.
- lateral.** Situated at, pertaining to, or coming from the side.
- lateral magnification.** The ratio of a length in the image to a corresponding length on the object. See magnification.
- lateral oblique.** An oblique photograph taken with the camera axis as nearly normal to the flight line as possible.



- latitude.** Angular distance measured on a meridian, referred to as being a line parallel to the equator.
- legend.** A description of the symbols used to interpret a map.
- lens.** Ground pieces of glass having curved surfaces, which when combined make an optical instrument that forms an image by changing the direction of rays of light.
- lens board.** A board mounted in the front of the camera to hold the lens.
- lens component.** The elements of a lens.
- lens distortion.** See aberration, distortion.
- lens element.** One part of a complex lens system.
- lens speed.** The rate of performance of a lens governed by the ratio of the equivalent focal length to the diameter of the aperture. See relative aperture.
- level surface.** A surface that is everywhere perpendicular to the pull of gravity. See geoid.
- light ray.** See ray of light.
- light slides.** A thin plate or material that is inserted in the camera to make it lighttight for interchanging magazines.
- linear magnification.** The ratio of a number of lines in an image to the corresponding lines in the object. See magnification.
- lithographic.** A method of making reproductions by printing. Different features can be shown in different colors.
- local datum.** An established datum of small areas. See geoid.
- locating back.** That part of a camera which holds the plate or film in the true focal plane. See pressure back, vacuum back.
- logarithm.** The exponent of the power of a fixed number.
- longitude.** Angular distance measured on a parallel and referred to as a line running north and south on a map.
- louver shutter.** A type consisting of small leaves located in front of or at the rear of the lens. See shutter.
- magazine.** That part of a camera which holds the film.
- magnetic azimuth.** The measurement of an angle between a line and magnetic north. See azimuth.
- magnetic declination.** The arc or angle that the magnetic needle makes between true north and magnetic north. See declination.
- magnification.** An apparent enlargement of an object. See lateral magnification, linear magnification.
- mantissa.** The decimal part of a logarithm.
- manuscript map.** The original drawing of a map, compiled from various existing data. See map.
- map.** A representation of the physical features of a portion of the earth's surface, on a flat surface and to a given scale. See base map, contour map, manuscript map, planimetric map, special-purpose map, substitute map, and topographic map.
- map data.** Basic information needed to construct a map.
- map grid.** Maps that are bisected by two sets of parallel lines drawn at right angles and equally spaced for the purpose of plotting position and scale distances.
- map parallel.** The intersection of the plane of the photograph and the ground reference plane. See principal plane.
- map plane.** Any horizontal plane from which the relief or planimetry of a map is plotted. See geoid.

- map projection.** A systematic drawing of lines on a plane surface to represent latitude and longitude.
- map projector.** An optical instrument used to project the image of a photograph or drawing so that it can be traced or compared with another drawing.
- Masonite.** A compressed board that is ideal for mounting photographs or maps.
- master glass negative.** A glass plate processed by contact printing to show the exact position of the fiducial marks. Used for record purposes.
- mean scale.** The scale used by taking the average of all measurements on a photograph; or, if in a flight strip, the average scale of all photographs.
- measuring unit.** The unit on a stereoplottting instrument used for measuring parallax in a spatial model.
- mechanical template.** A radial line control template made by mechanical triangulators.
- mechanical template triangulation.** A radial line control system made by the use of mechanical arms and parts. See radial line control, or triangulation.
- meniscus lens.** A type of lens in which the centers of curvature of the two surfaces lie on the same side of the lens.
- meridional arcs.** Arcs of measurement made on a meridian.
- meridional plane.** Any plane containing the polar axis. See polar bearing.
- micron.** One-thousandth part of a millimeter.
- military grid.** Grid lines representing 1,000 yd. on a map.
- mosaic.** An assembly of individual photographs, made by matching images to produce a single picture. See aerial mosaic, controlled mosaic, semicontrolled mosaic, and uncontrolled mosaic.
- multiple-lens camera.** One having two or more lenses and making composite photographs. See camera.
- nadir.** A point on the celestial sphere directly beneath the observer and directly opposite the zenith. See ground nadir, photographic nadir.
- nadir-point method.** A triangulation method that uses the nadir point for the radial center. See radial line control, or triangulation.
- nadir radial.** A radial line from a nadir point. See radial.
- natural features.** Natural, irregular-shaped characteristics of the terrain.
- nautical chart.** A hydrographic map made to show the depths of water for navigable purposes.
- negative.** A processed photographic film or glass plate with the image inverted.
- negative lens.** One capable of diverging parallel light rays. Does not produce a real focus.
- nine-lens camera.** One containing nine lenses mounted to produce a composite photograph, one vertical and eight obliques.
- nodal point.** One of two points on the optical axis of a lens such that a ray emergent through the second print is parallel to the ray incident through the first. See front nodal point, rear nodal point.
- North American datum of 1927.** The horizontal control datum of the North American continent established from a station in Kansas known as "Meade's ranch." See geoid.

- objective.** The lens in an optical instrument nearest the object.
- oblate spheroid.** A sphere flattened at the poles like the earth.
- oblique photograph.** One taken when the axis of the camera varies between the horizon and the vertical.
- oblique plotting instrument.** One used for plotting information from an oblique photograph.
- oblique sketchmaster.** An oblique plotting instrument used to sketch detail from an oblique photograph directly to a base sheet.
- occupy.** A surveying term meaning to set up over a given point.
- optical axis.** An imaginary line running through the optical centers of all the lens elements. See axis.
- optical flat.** An optical glass so finely polished and ground that it can be used to test flat surfaces of other optical glass.
- orientation.** Accurately locating control points and establishing lines of known length and direction on the face of the earth.
- origin.** The reference point from which angles and distances are made.
- orthogonal.** Lying at right angles.
- orthographic projection.** A projection made by lines perpendicular to a particular plane. See projection.
- overlap.** The amount by which one photograph covers another of the same area. See forward lap, side lap.
- overlapping pair.** Two photographs taken at different stations, but showing the same area, to be used for stereoscopic purposes.
- overlay.** A transparent material on which detail or data are traced from photographs or tracings.
- oxygen equipment.** Equipment used to supply oxygen to the crew while they are flying at a high altitude.
- pantograph.** An instrument consisting of several parallel arms that can be adjusted to draw detail from one scale on a map to some other desired scale.
- paper template.** Prepared for restituting patches to conform with measurements made on a mosaic.
- parallactic grids.** A uniform pattern of rectangular lines drawn on some transparent material and placed over a stereoscopic pair of photographs to provide a floating mark system.
- parallax.** The apparent displacement of an object in respect to a reference point when the point of observation changes. It is generally used to denote absolute stereoscopic parallax. See absolute stereoscopic parallax, Y parallax.
- parallax difference.** The difference in the absolute stereoscopic parallaxes of two points on a pair of photographs.
- parallax equation.** A formula used to compute the parallax factor of stereo-pairs.
- parallels.** Referred to as latitudes, which are imaginary lines parallel to the equator.
- pass point.** A point whose horizontal and vertical positions are determined by photogrammetric methods and used in orientation of photographs.
- pencil of light.** A bundle of rays. See ray of light.
- perspective center.** The point of origin or termination of perspective rays. See interior and exterior center, interior perspective center.
- perspective grid.** A network of lines on a photograph that represents the perspective of a systematic network of lines on the ground.

- perspective plane.** A plane containing the perspective center.
- perspective projection.** The projection of objects on a plane or curved surface as they appear to the eye. See projection.
- perspective ray.** A line joining object point and the perspective center.
- photogrammeter.** An instrument for measuring angles on a photograph to any point from the true perspective center. See goniometer.
- photogrammetric computer.** A slide rule devised to compute scale and parallax factor for aerial photographs.
- photogrammetric control.** That obtained from a photograph. See control.
- photogrammetric survey.** A survey made by using either ground or aerial photographs. See survey.
- photogrammetry.** The science of making measurement on photographs. See aerial photogrammetry, ground photogrammetry, stereo-photogrammetry.
- photograph.** A picture or image produced on a sensitized material by the action of light.
- photograph center.** The geometrical center of a photograph. In perfectly adjusted cameras, it is identical with the principal point.
- photograph perpendicular.** The perpendicular from the rear nodal point to the plane of the photograph.
- photographic coordinates.** Positions of points on a photograph, such as principal points, isocenter, fiducial mark, or base line. See coordinates.
- photographic nadir.** A point at which a vertical line through the center of the camera lens pierces the plane of the photograph. See nadir.
- phototheodolite.** An instrument combining the theodolite and a camera for use in ground surveying.
- plane or rectangular coordinates.** Relative position of points in a horizontal plane. See coordinates.
- plane table.** A small table mounted on a tripod to be used in the field for making small topographic maps.
- planimetric map.** One that shows the features but not the relief of an area. See map.
- planimetry.** Mensuration of plane surfaces.
- plat.** A plan or chart drawn to scale showing land boundaries and subdivisions but not additional features such as drainage or relief.
- plate center.** Same as photograph center.
- polar axis.** The primary axis of direction in a polar or spherical coordinate system.
- polar bearing.** The angle made by the intersection of the reference meridional plane and a line containing the point. See meridional plane.
- polar coordinates.** Relative position of points determined in relation to the earth's axis. See coordinates.
- polar distance.** Distance of the great-circle arc between a point and the pole.
- polyconic.** Many cones.
- polyconic projection.** A projection that can be constructed from existing tables and has values for every 1-minute intersection of latitude and longitude.
- Porro prism.** Two right-angle prisms cemented together to invert the image.

- positive.** A photograph having approximately the same rendition of light and shade as the subject.
- positive lens.** One that will converge parallel light rays to focus points.
- precision.** The refinement or quality produced in the performance of an operation.
- precision camera.** One constructed for precise detail work. See camera.
- preservative.** A chemical added to a developer to keep it from oxidizing.
- pressure back.** A type of camera construction that holds the film against the focal plane glass.
- pressure plate.** The mechanical part in the magazine that keeps the film pressed against the focal plane of the camera.
- primary control.** Control made in the field by surveying instruments with a high order of accuracy.
- principal line.** The trace of the principal plane upon the photograph.
- principal meridian.** The principal line.
- principal plane.** The vertical plane through the internal perspective center containing the plate perpendicular of an oblique photograph or any photograph that is not a true vertical. See axis of tilt, ground parallel, horizon trace, map parallel, and vanishing point.
- principal point.** The foot of the photograph perpendicular. The geometric center or the mechanical center of a photograph found by intersecting lines drawn from the opposite fiducial marks.
- principal-point method.** A triangulation method that uses the principal point of each photograph for the radial center. See radial line control, or triangulation.
- print.** A photographic copy made by contact printing or projection from a negative or transparent drawing.
- profile.** A drawing showing a vertical section.
- projection.** Transferring points from one surface to their corresponding positions on another surface by graphical or analytical methods. See orthographic projection, perspective projection.
- projection sheet.** One having necessary line intersections for the location of map data.
- projector.** An optical instrument devised to enlarge or reduce images.
- proportion.** Relation of one thing to another, or equality of ratios.
- protractor.** An instrument for measuring angles on paper, used for drawing and plotting.
- pseudoscopic effect.** An improper relation of one photograph to another producing a false or reverse relief effect.
- radial.** A line projecting out from a given point on a flat surface. See isoradial, nadir radial.
- radial center.** The point selected on a photograph from which radial lines to image points are drawn.
- radial line control, or triangulation.** A system of locating identical points on aerial photographs so that radial lines are made from each radial center to form a network of triangulation, which can be properly oriented to established control on a base sheet. See celluloid-template method, direct radial triangulation, mechanical-template triangulation, nadir-point method, principal-point method, and slotted-template plot.
- random acceleration.** Unintentional acceleration of an aircraft.
- rate of climb.** An aircraft's vertical rise from the surface of the earth, usually expressed in feet per minute.

- ratio computation sheet.** A form prepared to show the relationship of the distances between each radial center and radial points on the print to the corresponding distances on the base sheet. From this we can determine the axis of tilt in the print and the projection factor for producing a print that will fit the base sheet points.
- ratio print.** An enlargement or reduction print made to conform to certain measurements.
- ray of light.** A single element or line of light that appears to radiate from a bright object. See beam of light, pencil of light.
- rear nodal point.** The second, or emergent, nodal point. See nodal point.
- reconnaissance.** A general survey of a given territory for examination, usually preliminary to a more detailed survey.
- rectification.** Correcting for errors inherent in a photograph by distribution or reprojection of detail points to conform to corrected positions on a base sheet.
- rectoblque plotter.** An instrument devised to orient the control points that are identified on the obliques of a trimetrogon set to their horizontal radial line positions.
- reducer.** A chemical used to change the condition of the silver image on a sensitized material.
- reference spheroid.** A spheroid determined by revolving an ellipse about its shorter axis, used as a base for geodetic survey. See geoid.
- refracting prism.** A prism that deviates a beam of light by refraction.
- refraction.** The bending of light rays caused by light passing from one transparent medium to another.
- relative aperture.** The ratio of the equivalent focal length to the diameter of the entrance pupil. See lens speed.
- relative humidity.** A ratio of the amount of water in a certain amount of air, at a given temperature, to the amount of water the air could contain at the same temperature. See humidity.
- relative orientation.** Properly placing or fixing the points on one photograph to conform to those same points on an adjoining photograph as they existed when the photographs were taken. See absolute orientation, exterior orientation.
- relief models.** Models made from different materials to an enlarged scale representing the relief of the terrain by exaggeration.
- reproduction.** A copy of an original to different scales or proportions.
- restitute.** To restore points and detail of a photograph to their correct positions.
- restrainer.** A chemical used to check the action of another.
- revert.** To alter the relative position of an image.
- rhomboidal prism.** One used to displace the axis of a beam of light laterally.
- rhumb line.** A curved line on the surface of the earth, crossing all meridians at a constant angle. On a Mercator projection, this line is straight.
- right-angle prism.** One that deviates the axis of a beam of light 90 deg. and reverts the image.
- secant.** A straight line cutting a curve in two or more points. Also a trigonometric function that is the ratio of the hypotenuse of a right triangle to the side opposite the angle.

- secondary control.** That established by using picture points, as in radial triangulation.
- semicontrolled mosaic.** One made to conform to given direction or measurement. See mosaic.
- shutter.** A mechanism that interrupts the flow of light from reaching the sensitized plate. See between-the-lens shutter, focal-plane shutter, and louver shutter.
- side lap.** Overlap made between two parallel lines of flight. See overlap.
- sine.** A trigonometric function that is the ratio of the side opposite the angle to the hypotenuse.
- single-lens camera.** One having only one lens. See camera.
- slotted-template plot.** A radial line control network made by punching holes and slots in cardboard for triangulation. See radial line control, or triangulation.
- solar observation.** An observation made to determine the location of a point by finding the position of the sun with a surveying instrument at a certain time of the day.
- spatial model.** A model seen in relief as it appears under a stereoscopic instrument. It will appear to be in space.
- special-purpose map.** One compiled to show only certain needed information. See map.
- speed of a lens.** See relative aperture.
- stadia rod.** A graduated rod used in conjunction with a surveying instrument to measure distances.
- standard.** An exact value established as a rule in the measurement of a quantity, or a common practice or procedure.
- station.** A definite point from which various lengths of measurements are taken.
- statoscope.** A sensitive form of barometer by which small differences in altitude can be measured between successive air stations.
- stereocomparator.** Stereoscopic instrument devised for measuring parallax on a stereo-pair of photographs.
- stereogram.** A small stereo-pair properly oriented and mounted on a cardboard.
- stereophotogrammetry.** Photogrammetry that uses stereoscopic equipment. See photogrammetry.
- stereoscope.** A two-lens optical instrument used to produce a three-dimensional model when properly set up over a stereo-pair.
- stereoscopic fusion.** Combining two perspective images in such a manner as to create a mental impression of the third dimension.
- stereoscopic image.** A three-dimensional model that is the result of stereoscopic fusion.
- stereoscopic pair.** Two photographs of the same area taken from different angles and so matched to give the third dimension when viewed stereoscopically.
- stereoscopic vision.** The binocular vision with which the observer can see the relief when viewing a three-dimensional model.
- stereoscopy.** The science and art of producing stereoscopic effects and the methods by which they are produced. See binocular vision.
- striae.** Defects in the manufacturing of a piece of optical glass that resemble threadlike filaments.

- substitute center.** An easily identified point on an overlapping print used as a radial center in lieu of the principal point.
- substitute map.** One constructed for economical reasons to take the place of another. See map.
- survey.** The location of the position of points on or beneath the surface of the earth by making measurements. See aerial survey, ground survey, and photogrammetric survey.
- surveying camera.** One equipped with special measuring devices. See camera.
- surveyor.** One who surveys.
- swing.** The rotation of a photograph around its perpendicular.
- symbol.** A diagram, design, letter, or abbreviation placed on a map to represent certain characteristics as understood by the map reader.
- symmetrical lens.** A lens whose front group of elements and rear group of elements are alike in all respects.
- tangent.** Touching at a single point. Also a trigonometric function, which is the quotient of the sine divided by the cosine of the angle.
- telescope.** An optical instrument used to aid the eye or camera in registering distant objects.
- template.** A record of the directions of the radials taken from a photograph.
- terrain.** An area of ground considered as to its extent and topography.
- terrestrial.** Pertaining to the earth or ground.
- terrestrial horizon.** A visible junction of the sky and earth as it can be seen by the observer from the ground. See horizon.
- test chart.** A chart, with ruled lines or squares of various sizes and arrangements, made for testing lenses.
- thick lens.** A term used indicating that the thickness of the lens has been considered, distances being measured from the nodal point instead of the lens center.
- thin lens.** A term used to indicate that the thickness of a lens has been ignored and all distances have been measured from the lens center.
- tilt.** The angle between the plate perpendicular and a vertical through the air station. See *X* tilt, *Y* tilt.
- title.** Lettering put on a map to indicate the type, location, when and by whom compiled.
- tolerance.** The allowable variation from a standard.
- topographic map.** One showing planimetry and relief. See map.
- topographic sketch.** A small sketch, including only those features observed in a single stereoscopic model.
- topography.** Physical features of the earth's surface, including relief, natural and cultural characteristics.
- torque.** See cant and torque.
- transformer.** A specially designed projector printer to be used with a particular multiple-lens camera for making prints from the oblique negatives.
- traverse.** A method of surveying whereby the lengths and directions of lines connecting a series of stations are measured. They may be closed or open.
- triangulation.** A method of determining the location of a point by establishing a base line and computing angles and distances by trigonometry. See radial line control, or triangulation.



- trigonometry.** A branch of mathematics treating the relations between the sides and angles of a triangle.
- trimetrogon system.** A system of mapping involving the taking of three photographs (one vertical and two obliques) with three separate cameras, of equal or different focal length, at the same time; producing a composite, which covers an immense area, from horizon to horizon.
- trimming and mounting diagram.** A sketch showing how the prints of a transformed multiple-lens photograph should be trimmed and connected.
- true horizon.** The junction of the sky and earth as it would be if a plane parallel to the apparent horizon passed through it and the earth's center. See horizon.
- turning point.** A point or station used in surveying.
- uncontrolled mosaic.** One having no horizon control. See mosaic.
- vacuum back.** A locating back that utilizes a vacuum to hold the sensitive material in position. See locating back.
- vanishing point.** A point beyond sight or existence where a system of parallel lines on an oblique photograph seem to converge. See principal plane.
- vellum.** A transparent paper used for tracing.
- venturi tube.** A small tube constricted near the center and placed in the slip stream on an aircraft to produce a vacuum for operating small instruments.
- vernier.** A scale made to slide along the divisions of a graduated instrument to indicate parts of divisions.
- vertical control.** Control to indicate elevation above sea level of points on the earth's surface. See control.
- vertical control datum.** A level surface, such as sea level, from which to determine elevation. See geoid.
- vertical photograph.** A photograph taken from an aircraft with the axis of the camera in a vertical position.
- vertical sketchmaster.** An instrument devised to orient and rectify a vertical aerial photograph to a base sheet, for the purpose of sketching planimetry.
- view finder.** An instrument installed by the side of the camera to determine interval of exposure, the crab, relation of camera to flight line, and when to start and stop the taking of exposures.
- visibility.** The greatest distance toward the horizon that the eye can see.
- wedge.** A plate of glass whose transparency diminishes from one edge to the other, used to determine the density of negatives. Also used as a prism where a very small deviation is needed.
- wide-angle lens.** A lens that has an unusually large angular field of view, approximately 80 deg. or more.
- wing photograph.** Any one of the photographs taken by one of the oblique elements of a multiple-lens camera.
- X movement.** A horizontal movement parallel to the air base.
- X tilt.** Resultant rotation about the X axis of a photograph. See tilt.
- Y movement.** A horizontal movement perpendicular to the air base.
- Y parallax.** The difference of the perpendicular distances of two images from the vertical plane containing the air base. Denotes tilt or distortion in the model. See parallax.
- Y tilt.** Resultant rotation about the Y axis of a photograph. See tilt.

# BIBLIOGRAPHY

## REFERENCE BOOKS

- ANDERSON, R. O.: "Applied Photogrammetry," 3d ed., Edwards Bros., Inc., Ann Arbor, Mich., 1941.
- : "Rigorous Analysis of the Scale Point and Tilt Formulas," Edwards Bros., Inc., Ann Arbor, Mich., 1941.
- BAGLEY, LIEUT. COL. JAMES W.: "Aerophotography and Aerosurveying," McGraw-Hill Book Company, Inc., New York, 1941.
- BREED, C. B., and G. L. HOSMER: "Elementary Surveying," Vol. I, 7th ed., 1938. "Higher Surveying," Vol. II, 5th ed., 1940, John Wiley & Sons., Inc., New York.
- CHURCH, EARL: Analytical Computations in Aerial Photogrammetry, reprint from *Photogrammetric Engineering*, October, November, December, 1941.
- EARDELY, A. J.: "Aerial Photographs, Their Use and Interpretation," Harper & Brothers, New York, 1941-1942.
- MCKINLEY, ASHLEY C.: "Applied Aerial Photography," John Wiley & Sons, Inc., New York, 1929.
- MEES, C. E. K.: "Fundamentals of Photography," Vol. I, Eastman Kodak Company, Rochester, N. Y., 1938.
- RAISZ, ERWIN: "General Cartography," McGraw-Hill Book Company, Inc., New York, 1938.
- REEVES, DACHE M.: "Aerial Photographs," The Ronald Press Company, New York, 1927.
- SHARP, H. OAKELY: "Photogrammetry," 3d ed., John Wiley & Sons, Inc., New York, 1943.
- TALLY, CAPT. B. B.: "Engineering Applications of Aerial and Terrestrial Photogrammetry," Pitman Publishing Corporation, New York, 1938.
- WHITMORE, GEORGE D.: "Elements of Photogrammetry," International Textbook Company, Scranton, Pa., 1941.

## MANUALS AND GOVERNMENT PUBLICATIONS

- Topographic Drafting*, TM5-230, 1940.
- Surveying*, TM5-235, 1940.
- Elements of Map Projections*, Dietz and Adams.
- Elementary Map and Aerial Photography Reading*, FM21-25.
- Advanced Map and Aerial Photograph Reading*, FM21-26.
- Aerial Photography*, TM5-240.
- Basic Field Manual*, FM21-30.
- Tables for Polyconic Projection of Maps and Lengths of Terrestrial Arcs of Meridians and Parallels, 6th ed., U.S. Department of Commerce, U.S. Coast and Geodetic Survey.

Grid System for Progressive Maps in the United States, Special Publication 59, U.S. Department of Commerce, U.S. Coast and Geodetic Survey.

TECHNICAL JOURNALS

"The Chemistry of Photography," 6th ed., Mallinckrodt Chemical Co., 1940.

*Photogrammetric Engineering*, October, November, December, 1942, American Society of Photogrammetry.

## INDEX

### A

- Abrams, Aerial Survey Corporation, report, survey, 119
  - Aircraft Corporation, 99
  - School of Aerial Surveying, computation sheets, 35
- Stereoscopes, CF-8, 141
  - B-3, 141
- Absolute coordinates, 74
- Accessories, globes, 57
- Accuracy, for horizontal control, 32
  - for levels, 40
- Acid, pyrogallie, 121
- Adhesives for mosaics, 237
- Aerial equipment, 99
- Aerial photographs, how made, 99
  - mosaics from, 225
- Aerial Surveying, Abrams School of, 35
- Aeroprojector, multiplex, 174
  - accuracy of, 176
  - description of, 179
  - history of, 175
  - principle of, 174
  - purpose of, 175
- Agonic line, 24
- Airmaster, Cessna, 100
- Airplane, Abrams Explorer, 99
  - Beechcraft, 100
  - Bellanca, 100
  - Cessna Airmaster, 100
  - Curtis Robin, 100
  - Fairchild, 99
  - Lockheed Vegas, 100
  - photographic, 99
    - types used, 99
  - Ryan, 100
  - Stinson, 100

- Airplane, Waco, 100
- Alidade, 42
- Alimeter, 107
- Angles, bearing from, 24
  - classes of, 28
  - deflection, 28
  - horizontal, 29
  - measurement of, with compass, 26
    - with tape, 20
- Azimuth, 28
  - grid, 77

### B

- Backsight, 39
- Baseline, establishing, 155
  - stereoscopic, 155
- Bausch & Lomb Optical Company, 175
- Beam, compass, 85
- Bearing, angles from, 24
  - magnetic, 24
- Beechcraft, 100
- Bellanca, 100
- Bench mark, 39
- Board, drawing, 85
  - plotter, rectoblique, steps in operating, 244
- Bodies of water, identification of, 138
- Bow pens, 85
- Brush, identification of, 138
- Buildings, identification of, 141

### C

- Camera, 100
  - Abrams Explorer, 103
  - errors inherent in, 125

- Camera, law of, 110  
   mounts for, 108  
   types of, 100-103  
 Camouflage, definition of, 148  
   discipline in, 148  
   erection of material for, 148  
   interpretation of, 148  
   selection of material for, 148  
 Cessna Airmaster, 100  
 Chaining, 19  
 Change of scale between base and  
   print, 213  
 Characteristics of photographs, 150  
 Charts, portolano, 55  
 Chemistry of photographic proc-  
   essing, 121  
 Clearing, 92  
 Collimation marks, 154  
   how to use, 154  
 Compass, beam, 85  
   surveyor's, 23  
   uses of, 24  
 Compass rose, 55  
 Compilation, common errors in,  
   224  
 Computer, Abrams photogram-  
   metric, 173  
 Concealment, providing, methods  
   of, 149  
 Contour finder, Abrams, 159  
   assembly of, 159  
   operation of, 159  
 Contour lines, 93  
   construction of, 94  
 Contour pen, 85  
 Contours, 92  
   characteristics of, 96  
 Control, extension of, 210  
   primary, identifying, 204  
   radial line, restituting for, 200  
   radial line, template methods  
     of, 204  
   secondary, identifying, 208  
   straight-line method of, 239  
   transferring, 212  
   types and limits of, 49  
 Coordinates, 29-31, 74  
   absolute, 74  
     determining, 75  
     geographic, 75  
     grid, 75  
     origin of, 76  
     polar, 74  
     rectangular, 74  
     relative, 74  
   Correction graph, 167  
   Corrections for pull, 23  
     for sag, 23  
     for temperature, 23  
   Crow-quill pens, 85  
   Cultivated fields, indentification  
     of, 139  
   Curtis Robin, 100
- D
- Declination of magnetic needle,  
   24, 70  
 Departure, 30  
 Depression angle, computation of,  
   246  
 Description, sketchmaster, oblique,  
   256  
 Detail, tracing, 212  
 Developable surfaces, 59  
 Development of film, 122  
 Differential leveling, 39  
 Distance, print, 112  
 Drawing board, 85  
 Drawing, instruments for, 83  
   pencils, 83  
   pens, 83  
   topographic, 83  
 Drying film, 122
- E
- Earth, the, 58  
 Easel, how to use, 202  
 Easel template, projection, con-  
   structing a, 202  
 Elevation, determining differences  
   in, 166  
   of unknown points, 173

Equator, 58  
 Equipment, 219  
   installation of, 116  
   trimetrogon, Lazy Daisy, 248  
 Errors, caused by camera, 125  
   common, in compilation, 224  
   inherent, 125  
 Explorer, camera, Abrams, 101  
 Extension of control, 210

## F

Fairchild, airplane type, 71, 99  
 Fields, cultivated, 92  
 Film, development of, 121  
   drying of, 122  
   numbering of, 123  
 Finder, contour, Abrams, 159  
   assembling of, 159  
   operation of, 159  
 Flight, direction of, 113  
   planning of, 113  
   preparation for, 114  
   time necessary for, 114  
 Flight lines, 116  
   maps, 120  
   procedure, 117, 120  
   recording, 118  
 Focal length, 113  
 Focal-plane shutter, 105  
 Foresight, 39  
 Form lines, 93  
   ground, 153  
 Functions of angles, 10-11

## G

Geographic coordinates, 75  
 Geographic position, 75  
 Globes, 55  
   accessories, 57  
   construction of, 57  
   early, 57  
   gores, 57  
   relief, 57  
 Gores, globe, 57  
 Graph, correction, application of,  
   167

Graphic scale, 109  
   construction of, 112  
 Great circle, 58

## H

Hachures, 96  
 Hasty maps, 97  
   compiling, 98  
   methods of preparing, 98  
   tracing of detail on, 98  
 Height of instrument, 39  
 Hydroquinone, 121

## I

Identification, 137  
   of bodies of water, 138  
   of buildings and structures, 141  
   of cultivated fields, 138  
   of marshes, 138  
   of primary control, 204  
   of railroads, 140  
   of relief, 137  
   of roads, 140  
   of secondary control, 208  
   of streams, 137  
   of woods, 138  
 Inking, rules for, 86  
 Instruments, drawing, 83  
   orientation, 69  
 Interpolation of logarithms, 9  
 Interpretation, 134  
   cultural, 134  
   important characteristics of, 151  
   by light and shadow, 135  
   qualities to be studied by, 134  
   by shape and size, 136  
   by tone, 135  
 Intersection, 43  
 Intervalometer, 107  
 Isogonic charts, 24  
 Isogonic lines, 24

## J

Johnson table, 42

## L

- Laboratory procedure, 121
- Lap, end, 113
  - side, 113
- Law, cameras of, 110
- Lazy Daisy, triangulation, mechanical steps in preparing, 219
- Lens shutter, between-the-, 105
- Light and shadow, 135
- Lines, base, stereoscopic, 155
  - drawing on photographs, 156
  - ground form, characteristics of, 153
- Louver shutter, 104

## M

- Magnetic, bearing, 24
  - meridian, 24
- Maintenance, oblique sketchmaster, 260
  - rectoblique plotter board, 246
  - vertical sketchmaster, 256
- Maps, 55
  - flight lines on, 116, 120
  - hasty, 97
  - military, 77
  - projection, 58
  - types of, 56
- Marsh, 92
  - identification of, 138
- Measurement, of angles with tape, 20
  - of distances, 19
- Measuring angles, 20, 26
  - direction, 23
  - on level ground, 20
  - methods of, 19
  - on sloping ground, 20
- Mechanical triangulators for trimetrogon, 248
  - how used, 218
- Mercator projection, 66
  - advantages of, 67
- Meridian, magnetic, 24

- Metol, 121
- Military grid, 76
  - application to polyconic projection, 76
- Military maps, 77
- Military and topographic symbols, 90-91
- Mistakes, in measurement, 23
  - in use of compass, 26
- Model, multiplex, leveling, 184
  - material for, 189
- Models, plastic and wood, 92
- Mosaics, adhesives for, 237
  - from aerial photographs, 225
  - definition of, 224
  - how to make, 225
  - kinds of, 229
  - requirements for making, 225
  - steps in preparing, 233
- Mounts, camera, 108
- Multiplex aeroprinter, 174
  - accuracy of, 176
  - description of, 179
  - history of, 175
  - operation of, 180
  - principle of, 174
  - purpose of, 175

## N

- North, determination of true, 71
  - general, 70, 77
  - grid, 71
  - magnetic, 75
  - true, 70
- Numbering of film, 123

## O

- Oblique, photography, 120
  - sketchmaster, 256
- Observation of camouflage, 150
- Operation, of oblique sketchmaster, 252
  - of vertical sketchmaster, 258
- Orientation, 55, 69
  - application, 69

Orientation, definition, 69  
 by direction, 72  
 of maps, 70  
 of templates, 222  
 use of, 69  
 Orienting, of photographs, 155, 240  
 officers, 69

## P

Pantograph, 85  
 Parallax factor, 165  
 computing of, 165  
 Pencils, drawing, 83  
 Pens, bow, 85  
 contour, 85  
 crow-quill, 85  
 drawing, 83  
 railroad, 85  
 ruling, 85  
 Photographic airplane, 99  
 Photographic processing, chem-  
 istry of, 121  
 Photographs, errors inherent, 125  
 characteristics of, 150  
 kinds of, 150  
 numbering of, 115  
 orienting, 155, 240  
 restitution and rectification of,  
 196  
 steps in preparing, for contour  
 finder, 161  
 Photography, oblique, 120  
 vertical, 113  
 Plane table, 41-42  
 advantages of, 41  
 definition, 41  
 Planning, flight, the, 113  
 Plotter, rectoblique, 242  
 steps in operating, 244  
 Plotting, geographic position, 75  
 methods of, 74  
 Polar coordinates, 74  
 Polyconic projection, application  
 of, 76  
 steps in constructing, 63  
 Portolan charts, 55

Portolan position, determination  
 of, 72  
 Precaution, in taping, 41  
 in use of tape, 23  
 Principal point, 154  
 locating, 154  
 transferring, with stereoscope,  
 154  
 Print, adjusting to instrument, 162  
 distance, 112  
 scale, 109  
 Printing, photographic, 123  
 Problem, three point, 44  
 Projection, conformal conic, 61  
 conical, 60  
 cylindrical, 59  
 interrelated, 66  
 Lambert, 66  
 map, 57  
 Mercator, 66  
 sheet, 209, 216  
 stereographic, 66  
 template easel, how to make, 202  
 Projector, restitutional, 199  
 Protractor, 86  
 Pyrogallic acid, 121

## Q

Quadrant, 58

## R

Radial line control, methods of, 204  
 Railroad, identification of, 140  
 Ratio and proportion, 6  
 definition of, 6  
 steps in solving, 7  
 Reconnaissance officer, 69  
 Rectangular coordinates, 74  
 Rectification, of aerial photo-  
 graphs, 196  
 definition, 196  
 directions for, 197  
 need for, 196  
 Rectoblique plotter, 241  
 how used, 260



- Relative coordinates, 74  
 Relief, cardboard layer method of  
   showing, 188  
   global, 57  
   indentification of, 137  
   materials for, 187  
   models, 186  
   profile method, 194  
   sandbox method, 191  
   scales for, 187  
   topographic, 186  
 Representative fraction, 109  
 Requirements for mosaic, 225  
 Resection, 43  
 Restitution, definition of, 196  
   of aerial photographs, 196  
   for differences of scale, 200  
   locating unknown points by, 196  
   need for, 196  
   photographic, 199  
   for radial line control, 200  
   for tip, tilt, 200  
 Roads, indentification of, 140  
 Ruling pens, 85  
 Ryan, 100
- S
- Sand, 92  
 Scale, change of, between base  
   and print, 213  
   graphic, 110  
   of prints, 109, 113  
   representative fraction, 109  
   restituting for difference in, 200  
   steps in finding, 112  
 Scales, measuring, 86  
 Scaling a restituted projection, 202  
 Scheimflug, Theodor, 175  
 School, Abrams Aerial Surveying,  
   35  
 Shadow, 135  
 Shape and size, 136  
 Shore lines, 91  
 Shutter, 104  
   focal plane, 104  
   between the lens, 105  
   Louver, 104  
   Sine law, 48  
   Sketch board, 45  
     determining elevations by, 46  
   Sketchmaster, description, 256  
     how used, 260  
     maintenance of, 256  
     oblique, 256  
     operation of, 252, 258  
     vertical, 249  
   Slide rule, dividing by, 3  
     division, rules for, 6  
     multiplication, rules for, 5  
     multiplying with, 1  
     reading the, 1  
     square root, 4  
     squaring a number, 4  
   Slotted template, compilation  
     from, 215  
     how made, 215  
     procedure in, 215  
   Solutions, triangles, 13  
   Sphere, cylindrical development of,  
     59  
   Spheroid, Clarke's, 17  
     oblate, 58  
   Steps in preparing a mosaic, 233  
   Stereographic projection, 66  
   Stereoplotting instruments, 159  
   Stereoscope, 141  
     Abrams B-3, 141  
     Abrams CF-8, 141  
     transferring principal point, 154  
     uses of, 150  
   Stereoscopically, methods of see-  
     ing, 127  
   Stereovision, 127  
     exercises in, 133  
     methods of approach to, 127  
     purposes of, 127  
     theory of, 133  
   Stinson, 100  
   Straight-line control, 239  
   Streams, identification of, 137  
   Structures, identification of, 141  
   Survey, Abrams Aerial, report of,  
     119  
   Surveys, factors controlling, 17

- Surveying, Aerial, Abrams School  
     of, 35  
     definition of, 17  
     methods of, 74  
     uses of, 17  
 Symbols, composition, 88  
     kinds of, 86  
     reasons for use, 86  
     sample sheets of, 89  
     shading of, 87, 92  
     specifications for, 91  
     topographic, 86
- T
- T square, 85  
 Template, compilation procedure  
     for assembly of, 215, 217, 222  
     compilation procedure for cellu-  
     loid, 206  
     easel, steps in construction of,  
     202  
     finished, 210  
     methods of radial line control,  
     204  
         how to use, 202  
     orientation of, 210, 222  
     preparation, 210  
     slotted, how made, 215  
 Three-point problem, 44  
 Tilt, 126  
     elimination of, 168  
     restitution for, 200  
 Tip, 126  
     elimination of, 168  
     restitution for, 200  
 Tone, 134-135  
 Topographic symbol, 86  
     kinds, 86  
     reasons for use, 86  
     relief models, 186  
 Tracing, detail, planimetric, 98,  
     212  
 Training for surveying, 17  
 Transit, precautions in use of, 37  
     reading angles with, 26  
     setting up, 27  
 Traverse layout sheet, 36  
     methods of plotting, 29  
 Trees, 91  
     shade, 91  
 Triangle, of error, 45  
     right angle, solution of, 13  
 Triangles, drawing, 85  
 Triangulation, 47  
 Triangulators, Lazy Daisy me-  
     chanical, 218  
     how used, 218  
     preparation of, 219  
     for trimetrogon, 247  
 Trigonometry, application of, 14  
     definition of, 10  
     tables in, use of, 11  
 Trimetrogon, world charting sys-  
     tem of, 241  
     mechanical triangulator, Lazy  
     Daisy equipment for, 248  
 True north, determination of, 71  
     by celestial body, 71  
     by pocket watch, 71  
 Turning point, 39
- U
- U.S. Coast & Geodetic Survey, 24,  
     47-48, 62
- V
- Vernier, 26  
 Vertical photography, 113  
 Vertical sketchmaster, 249  
 View finder, 106
- W
- Waco, 100  
 Water lines, 191  
 Woods, identification of, 138  
 World charting, trimetrogon sys-  
     tem for, 241
- Z
- Zeiss-aero-topograph, 175  
     operation of, 180  
 Zones, 76  
     overlapping, 77

