

Practical Sheet Metal Duct Construction

A Treatise in the Construction and
Erection of Heating and
Ventilating Ducts

BY WILLIAM NEUBECKER

Illustrated by Two Hundred and Seven-
teen Engravings, Mostly from
Pen and Ink Drawings

NEW YORK

The Sheet Metal Publication Company

1916

COPYRIGHT, 1916
BY
THE SHEET METAL PUBLISHING COMPANY

218019

MAY 22 1918.

TIDV

N39

69 36-105

CONTENTS

	PAGE
INTRODUCTORY. - - - - -	5
CHAPTER I.	
TOOLS, MACHINERY AND MATERIALS - - -	7
CHAPTER II.	
SHEET METAL WORK IN HEATING AND VENTILATING SYSTEMS - - - - -	26
CHAPTER III.	
CUTTING MATERIAL, BENDING, FORMING, SEAMING, GROOVING AND BRACING - - - - -	34 ✓
CHAPTER IV.	
CONSTRUCTING THE VARIOUS SLIP JOINTS - - -	52 ✓
CHAPTER V.	
HANGING CEILING DUCTS—SUPPORTING AND FASTENING DUCTS - - - - -	63
CHAPTER VI.	
METHODS OF LAYING OUT AND CONSTRUCTING THE ELBOWS - - - - -	77 ✓
CHAPTER VII.	
CONSTRUCTING REGISTER BOXES, CLEANOUTS AND CEILING VENTILATORS - - - - -	85
CHAPTER VIII.	
REGISTERS FOR HEATING AND VENTILATING DUCTS	106
CHAPTER IX.	
FASTENING AND ADJUSTING REGISTERS - - -	113 ✓

CONTENTS—*Continued*

	PAGE
CHAPTER X.	
✓CONNECTING HEATING AND VENTILATING DUCTS -	121
CHAPTER XI.	
DUCTS FOR DIRECT-INDIRECT HEATING - - -	129
CHAPTER XII.	
CONSTRUCTION OF CASINGS FOR INDIRECT HEATING -	136
CHAPTER XIII.	
ASSEMBLING CASINGS AND CONSTRUCTING AIR FILTERS - - - - -	142
CHAPTER XIV.	
THE CONSTRUCTION OF MIXING DAMPERS - -	150
CHAPTER XV.	
MAKING DAMPERS FOR LARGE DUCTS - - -	160
CHAPTER XVI.	
CALCULATING AREAS OF PIPES AND DUCTS - -	169
CHAPTER XVII.	
VARIOUS TYPES OF VENTILATORS - - - -	174
CHAPTER XVIII.	
CONSTRUCTION OF A LARGE VENTILATOR - -	179

INTRODUCTORY

The modern demand for economy and efficiency in methods of production have given a strong impetus to specialization in the various branches of sheet metal work. In the larger cities are found very many shops that contract exclusively for heating and ventilating, exhaust pipes and ducts, etc. Only the well equipped, well-manned plant and only the skillful operator thoroughly familiar with his special calling, can readily take advantage of the opportunities presented in this large field.

Many excellent books have been prepared for the guidance of operators in various distinct branches of sheet metal work but none has heretofore been designed to cover the subject of heating and ventilating duct construction. The plan of the present work is to take up each operation, and by means of descriptions, with in nearly all cases accompanying illustrations, to show all operations incident to the construction and erection of heating and ventilating ducts. The reader may thus be equipped with a complete series of practical methods, available almost at a glance.

The material has been compiled from the columns of SHEET METAL where it was presented serially, with the definite purpose of its subsequent publication in book form. The illustrations, mainly from carefully made pen and ink drawings, are a special feature.

It should be stated that the operator whose business it becomes to install heating and ventilating pipes should thoroughly understand reading architectural plans such as are used in building construction; that is, he should be familiar with the methods by which the various means used in heating and ventilation are indicated upon plans, elevations and sections, as the furnaces, blowers, steam pipes and coils, air ducts, registers, ventilators, smoke flues, etc., as well as with the usual locations of the same, so that he may trace the courses of ducts and pipes from basement up through the several floors, locating bends, risers, junctions, etc. He should also understand the methods of calculating capacities of ducts and amount of heating surface of pipes and coils and the requirements of the same, as well as areas of wall and glass surfaces with reference to the heat units required. It may be said that the best way of learning how to read plans is to learn how plans, sections, etc., are made. This is a subject which is taught in all technical schools and in courses given by correspondence. Any attempt to illustrate this subject as it should be done, would involve the presentation of at least one complete set of heating engineers' plans, while it is to be doubted if one set, as designed for any particular case, would include everything usually indicated upon plans made for this purpose.

CHAPTER I.

TOOLS, MACHINERY AND MATERIALS

It may be presumed that some of our readers are not wholly familiar with shop practice and equipment and have not had free access to the catalogues of manufacturers and dealers in sheet metal workers machinery. For the benefit of those who are not fully acquainted with the tools, machinery and material in a fully-equipped plant which turns out heating and ventilating pipes, we present the following lists, which though not necessarily complete, are suggestive of the equipment of shops making a feature of heating and ventilating duct work.

Hand Tools.

Breast drill.
Buffalo shears.
Cold chisel.
Cross cut and rip saw.
Circular shears.
Center punch.
Combination screw driver
and reamer.
Clamp vise.
Compass saw.
Double cutting shears.
File.
Flat plyers.
Four and eight foot steel
straight edges.
Grooving Tool.
Grindstone.
Hollow punch.
Hack saw.

Handy tongs.
Hand drill.
Hand punch with changeable
punches and dies.
Hand drill for stone.
Hand drill for brick.
Hand vise.
Iron clamp.
Left handed shears.
Mallet.
Malleable iron ladle.
Melting pot for lead.
Oil stone.
Oilers.
Prick punch.
Pointed plyers.
Plumb line.
Riveting hammer.
Right handed shears.
Rasp.

Round faced dolly.
 Rivet or solid punch.
 Rivet set and header.
 Ratchet brace and bits.
 Setting hammer.
 Slitting shears.
 Steel tape measure.
 Small steel square.
 Small wrench.
 Small spirit level (3 inch).
 Screw driver.
 Soldering coppers.
 Scratch awl.
 Small lead cakes for punching purposes.
 Small blacksmith's hammer.
 Seamless stove pipe stake.
 Square faced dolly.
 Two-foot rule.
 Twenty-inch spirit level.
 Twelve-inch spirit level.
 Two-foot steel square.
 Universal French shears.
 Vise plyers.
 Wire chisel.
 Wing dividers.
 Wire gauge.

Machines.

Anvil.
 Bench shear holder.
 Beading machine.
 Blacksmith's punch.
 Bench shears.
 Bench plate.
 Brace bender.
 Bar rest.
 Bevel mandrel stake.
 Charcoal furnace.
 Crimper and beader combined.
 Combination punch and shears.
 Deep throat lever punch.
 Deep throat lever shears.
 Double seaming stake with four heads.
 Eight or ten-foot squaring shears (according to the length of sheet iron used in stock).

Eight or ten-foot giant groover, operated by hand.
 Eight or ten-foot giant groover, operated by power.
 Eight or ten-foot cornice brake.
 Four, six, eight and ten-foot grooving bars, made from steel rails.
 Floor machine, standard.
 Gas furnace.
 Gasoline furnace.
 Hollow mandrel stake.
 Heavy beading machine.
 Machine, standard.
 Mechanic's vise.
 Plain forming rolls.
 Portable lever punch.
 Revolving bench plate.
 Set of machines for beading furnace pipe.
 Slip roll former.
 Small size blacksmith forge.
 Screw punch.
 Square head stake.
 Small turner.
 Sheet iron folder.
 Thirty-six-inch groover.
 Thirty-six-inch squaring shears.
 Three-foot cornice brake.
 Twenty-inch groover.
 Upright drill.

Materials and Stock for Heating, Ventilating and Exhaust Work.

Asbestos paper.
 Asbestos paper paste.
 Black sheet iron.
 Black and galvanized band iron.
 Black and galvanized angle iron.
 Black galvanized iron rods.
 Black and tinned iron rivets, with different shaped heads.
 Black and tinned iron burrs.
 Black and galvanized iron stove bolts, with different shaped heads.

Black and galvanized iron expansion bolts, with different style heads.	Corrugated air cells asbestos sheathing.
Black and galvanized iron washers.	Galvanized sheet iron.
Brass safety chain.	Galvanized iron wire.
Brass and steel wood screws.	Galvanized iron turn buckles.
Brass machine screws, with different shaped heads.	Galvanized hoop iron.
Black and galvanized iron wall hooks.	Galvanized and brass pulleys.
Black and galvanized round and square dampers.	Half and Half solder.
Black and galvanized wind or blast gates.	Hard brass strips and angles.
	Hoop brass.
	Planished sheet iron.
	Sheet lead.
	Steel wire nails.

Sizes and Standard Gauges of Black Sheets, Etc.

The following table gives the United States standard gauge for all uncoated sheets and plates of iron and steel.

The stock sizes of the sheets are usually from 20 inches to not over 36 inches wide and in lengths from 72 inches to not over 144 inches. However, special sizes can be obtained from the mill if a sufficient quantity is required. The sheets are usually delivered in about 150 to 160 pound bundles, the number of sheets to a bundle being regulated according to the gauge of iron.

Special Pointers

The illustrations following from Figs. 1 to 12 inclusive, show some of the more important handy equipment about which further mention will be made. The tool shown in Fig. 1 is a combination screw-driver and reamer turning on the pivot at the center so that either the screw-driver or reamer may be used as desired, for reaming out holes or screwing in bolts. The plumb bob and line shown in Fig. 2 is

employed to obtain true perpendicular erections of duct work. The plumb bob is used as indicated in the cut to the right. Fig. 3 shows a handy knock-about telescope tool chest made of number 24 galvanized

The U. S. Standard Gauge
For all Uncoated Sheets and Plates of Iron.

Number of Gauge	Thickness in Fractions of an Inch	Thickness in Decimal Parts of an Inch	Weight per Sq. Ft. in Oz.	Weight per Sq. Foot in Lbs.
0000000	1-2	.5	320	20.
000000	15-32	.46875	300	18.75
00000	7-16	.4375	290	17.50
0000	13-32	.40625	260	16.25
000	3-8	.375	240	15.
00	11-32	.34375	220	13.75
0	5-16	.3125	200	12.50
1	9-32	.28125	180	11.25
2	17-64	.265625	170	10.625
3	1-4	.25	160	10.
4	15-64	.234375	150	9.375
5	7-32	.21875	140	8.75
6	13-64	.203125	130	8.125
7	3-16	.1875	120	7.5
8	11-64	.171875	110	6.875
9	5-32	.15625	100	6.25
10	9-64	.140625	90	5.625
11	1-8	.125	80	5.
12	7-64	.109375	70	4.375
13	3-32	.09375	60	3.75
14	5-64	.078125	50	3.125
15	9-128	.0703125	45	2.8125
16	1-16	.0625	40	2.5
17	9-160	.05625	36	2.25
18	1-20	.05	32	2.
19	7-160	.04375	28	1.75
20	3-80	.0375	24	1.50
21	11-320	.034375	22	1.375
22	1-32	.03125	20	1.25
23	9-320	.028125	18	1.125
24	1-40	.025	16	1.
25	7-320	.021875	14	.875
26	3-160	.01875	12	.75
27	11-640	.0171875	11	.6875
28	1-64	.015625	10	.625
29	9-640	.0140625	9	.5625
30	1-80	.0125	8	.5
31	7-640	.0109375	7	.4375
32	13-1280	.01015625	6½	.40625
33	3-320	.009375	6	.375
34	11-1280	.00859375	5½	.34375
35	5-640	.0078125	5	.3125
36	9-1280	.00703125	4½	.28125
37	17-2560	.006640625	4¼	.265625
38	1-160	.00625	4	.25

iron; the working dimensions for its construction being shown in Fig. 4. For punching rivet holes in sheet metal previous to bending or rolling, use is sometimes made of small lead cakes. The cakes are cast in various sizes, in the shop, by means of beveled black iron

pans of the required size as shown in Fig. 5. The sizes of the various lead cakes in use are indicated in Fig. 6. For double seaming elbows, whether curved or angular, "dollys" are used, two styles of which are shown in Figs. 7 and 8. For bending band or angle iron braces for the large ducts, a bar rest is employed

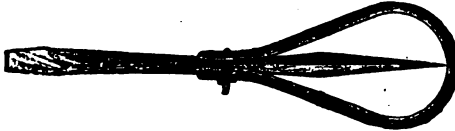

Fig. 1—Combination Screw Driver and Reamer

as shown in Fig. 9, the upper horizontal rod turning on a pivot, thus allowing the band or angle to move along at will for bending or forging the braces. The set screw shown, allows the standard to be raised or lowered as required. Fig. 10 shows a grooving bar

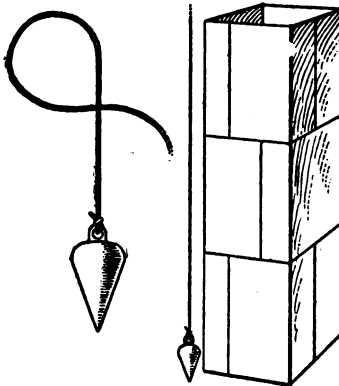

Fig. 2—Plumb Bob and Line

made from a steel rail, with a perfectly smooth surface along the top B, with the proper groove cut in same at A. The method of using this bar will be ex-

plained further along. Fig. 11 shows the type of stationary bench usually employed in the shop where plenty of room is available. When the space is limited, movable benches may be used as shown in Fig. 12 where the bench is laid on wooden horses as shown.

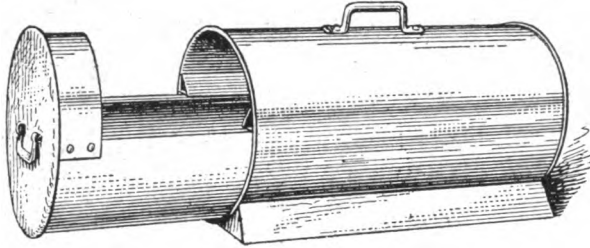

Fig. 3—Sheet Metal Telescope Tool Chest Partly Opened

When opening the bands around a bundle of sheet metal, a cold chisel and hammer should be used, as shown at A in Fig. 13, as this method will not impair the smooth surface on the sheet. The bands should not be opened, as is usually done, by driving the pean

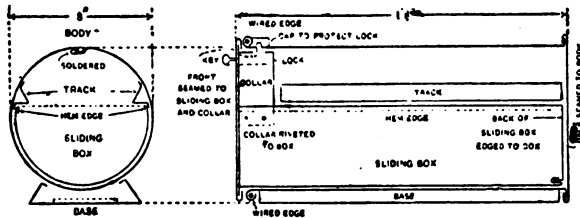

Fig. 4—Working Measurements for Round Tool Chest

of the hammer under the band as indicated at B, which dents the surface of not only the top sheet, but sometimes three or four sheets below it.

The lighter gauges of the metal are used for stove-pipes, pans, etc.; while the heavier gauges are em-

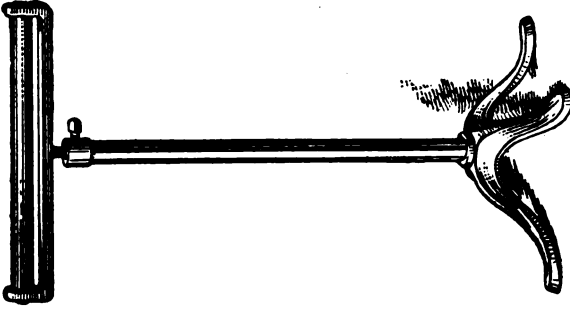

Fig. 9—Bar Rest Used in Connection with Forging and Bending

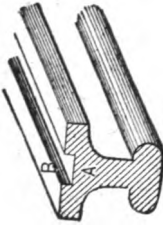

Fig. 10—Grooving Bar Made from Steel Rail

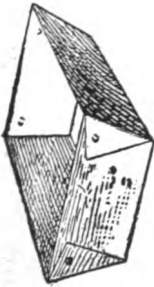

Fig. 5—Pan with Beveled Sides for Casting Lead Cakes



Fig. 6—Sizes of Lead Cakes from Melted Scrap for Punching Sheet Metal



Fig. 7—Square Faced Dolly



Fig. 8—Round Faced Dolly

ployed for making boilers, large smokestacks, ducts, drums, etc.

Planished Sheet Iron

Planished sheet iron is made from genuine charcoal hammered bloom iron; has a dark blue glossy surface,

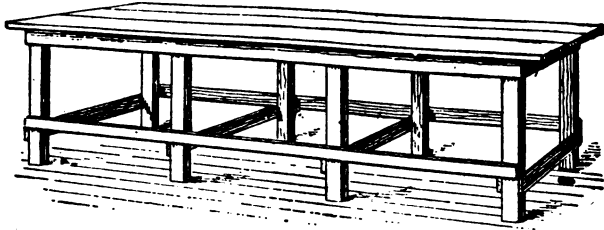

Fig. 11—A Stationary Bench

which is practically impervious to oxidation. Planished sheet iron is equal to the once famous Russia sheet iron. It is used for high-grade ranges, radia-

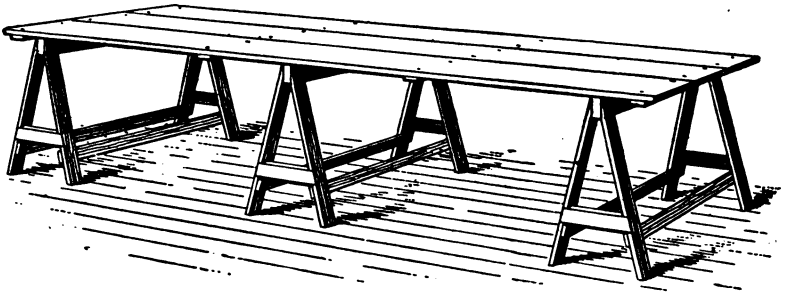
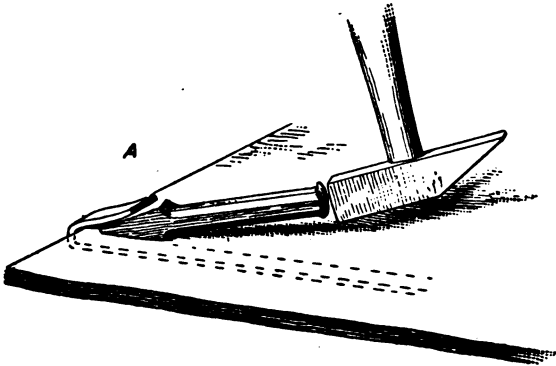

Fig. 12—A Movable Bench

tors, locomotive jackets, automobile seats and hoods, as well as other work in which appearance is considered. When it is used in connection with brass trimmings, a handsome appearance is secured. A table

giving the standard gauges and sizes may be found in handbooks and catalogues furnished by several manufacturers.



The Right Way

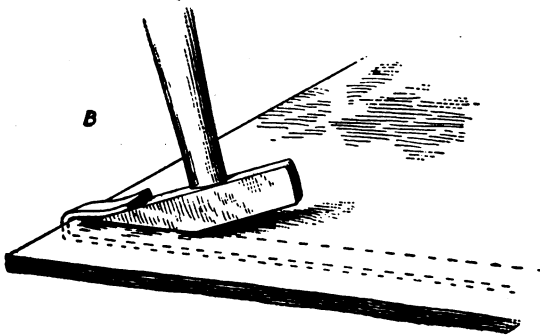

The Wrong Way

Fig. 13—Opening the Bundles of Sheet Iron

Galvanized Sheet Iron

Galvanized sheet iron can be obtained in similar gauges and sizes as given in the table for uncoated

sheets. The usual gauges used for constructive pipe work are from Nos. 14 to 24, inclusive, the weight per sheet, number of sheets to the bundle and weight per bundle being given in a table of average weights of standard sizes (covering 24" \times 72" to 36" \times 120", inclusive), also to be found in all of the manufacturers' catalogs.

Storing the Sheets

After the bundles have been opened in the shop, the stock sheets are stored on shelves constructed for the purpose, as shown in Fig. 14, the shelves being

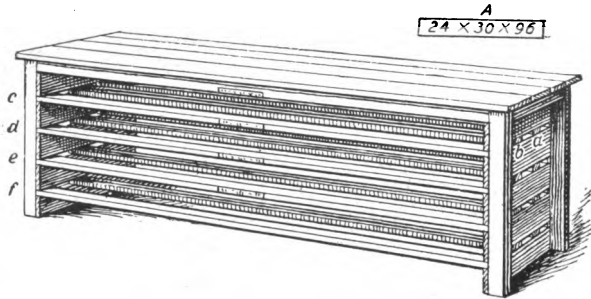

Fig. 14—Combined Bench and Sheet Metal Rack

open as indicated by **a b** and run through the entire length of the bench, the outer strips being shown by **c d e f**. To indicate the various gauge and size of the sheet on each shelf, galvanized iron tags, with the number and size marked thereon, are nailed over each shelf similar to A, which reads: No. 24 gauge, 30 in. wide, 96 in. long.

Sheet Lead

Sheet lead is used in constructing the exhaust ducts, which carry away the fumes of sulphuric acid from the battery rooms in large buildings in which batteries

are used, the ducts being similar to Fig. 15, whose construction will be explained in course. Any other metal

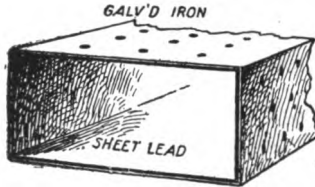

Fig. 15—Sheet Lead Exhaust Duct

such as galvanized iron, would be destroyed by the fumes of the acid. The following table gives the approximate thicknesses and weights of sheet lead:

Approximate thickness.....	1/64,	1/43,	1/32,	1/25,	3/64,	1/16,	5/64,	3/32,	1/8,	1/4 in.
Weight per sq. foot	1,	1½,	2,	2½,	3,	4,	5,	6,	8	16 lbs.

Brass Bands and Angles

Brass bands and angles are used as trimmings on

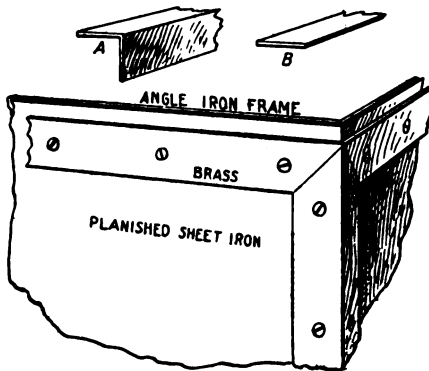

Fig. 16—The Use of Angles and Brass Bands

any piece of work made from planished sheet metal, as shown in Fig. 16.

Band and Angle Iron

Black and galvanized band and angle irons are



Fig. 17—Band Iron Hangers

used to make braces, hangers, etc., as shown in Fig. 17. The band iron or steel should be soft, so as to

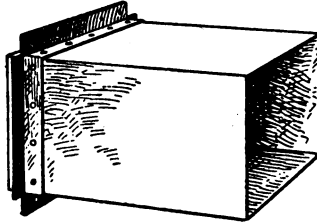

Fig. 18—Angle Iron Stiffeners

allow the bends to be made cold, i.e., without heating. Any desired thickness and width can be obtained.

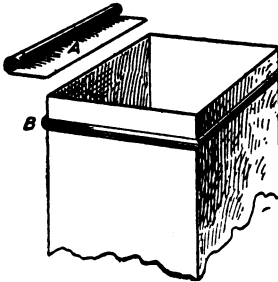

Fig. 19—Iron Rod Stiffeners

Angle iron is used chiefly for stiffeners around large size ducts to keep the middle of the duct from sagging, as shown in Fig. 18.

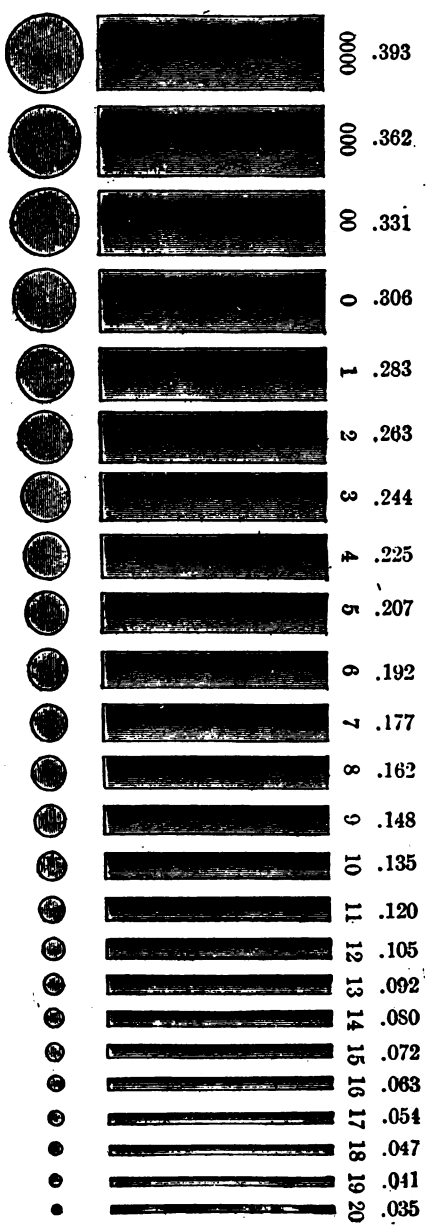

Fig. 20—Stubb's Wire Gauge

Black and Galvanized Iron Rod

Black and galvanized iron rod is used for hanging heavy round ducts, as well as for a stop edge in the slip end of the duct B in Fig. 19, the rod being encased as shown in diagram A.

Tinned or Galvanized Wire

is used to hang small size pipes, etc. The standard sizes of wire and rod by Stubb's wire gauge with their various thicknesses are shown in Fig. 20.

The Brass Safety Chain

is used for operating over pulleys, the various slides, dampers, registers, etc. A safety chain such as is



Fig. 21—Brass Safety Chain

shown in Fig. 21 has links which are practically indestructible, and is capable of standing much wear and tear, lasting indefinitely.

Rivets

Black, tinned, copper or brass rivets can be obtained in weights from 8 ounces to 12 pounds to the 1,000. Flat head tinned iron rivets are chiefly in use, these being made from soft Norway iron. The 2-ounce rivet is most generally used in riveting metal ducts, etc. The various rivets in use have heads which are known as flat, round, countersunk and coneheaded.

Burrs

The burr shown in Fig. 22 is used in riveting, and keeps the sheet metal from spreading and tearing



Fig. 22—Burr Used in Riveting

during that process, and is used as shown at A. Burrs come in different sizes for the rivets in use.

Stove Bolts

Flat and round-headed stove bolts and nuts are used for bolting together angles, braces, etc., which are not riveted.

The Washer

The washer shown by A in Fig. 23 is used in connection with the bolts, as shown at B, and gives the head of the bolt a flat bearing against the sheet metal,

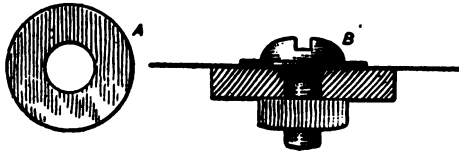

Fig. 23—Washer Used with Bolts

thus preventing the tearing of the bolt head through the sheet, the latter being subject to a strain when the braces or other iron work are put in position.

The Expansion Screw

The expansion screw A shown in Fig. 24 is used to fasten registers to marble walls. The screw is usually a brass or nickel plated round headed wood screw. The anchor a is made of a lead composition metal in

one piece and is so constructed that the screw cuts its own thread, thereby allowing the use of any kind of screw. This anchor *a* is placed into the hole previously drilled into the marble, stone or iron, after which the

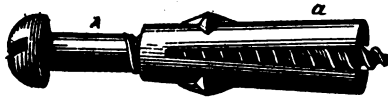

Fig. 24—Expansion Screw

object to be fastened is screwed in place. The screw expands the lead anchor *a* and holds it firmly. On heavier work, such as the fastening of heavy iron braces and hangers, bolts having an eye or a square head can be used.

Wood and Machine Screws

Wood screws employed for fastening registers, braces, flanges, etc., may be obtained in any size made of steel, coppered, brass, nickel plated, tinned, galvanized, etc., according to requirement.

Machine screws are used to fasten the brass trimmings to planished sheet iron work, which in turn is fastened to angle iron frame work, into which holes have been tapped to receive the proper size of screws. These screws, unlike common wood screws, are not gimlet pointed, and come with three styles of heads, known as flat, round and fillister.

Steel Wire Nails

The sizes of steel wire nails are usually 1, 1¼, 1½ and 2 inches long. They are made from Nos. 9, 10, 11 and 12 wire respectively.

Wall Hooks

When wire is used for fastening round or small

size square pipe, a wall hook may be obtained which can be used in both wood and brick joints.

Pulleys

Encased and tackle pulleys, brass or galvanized, are used in connection with brass safety chains for operating dampers, blast gates, etc. Where the ceiling is of wood they are screwed in. If the ceiling or side wall is of marble, stone or brick, holes are drilled and a lead anchor, previously described in connection with expansion bolts, is used into which the screw of the pulley can be firmly secured.

Dampers

Among the various styles of dampers used for heater pipes, smoke pipes and brick flues are those made of malleable iron and of sheet metal. Fig. 25 shows

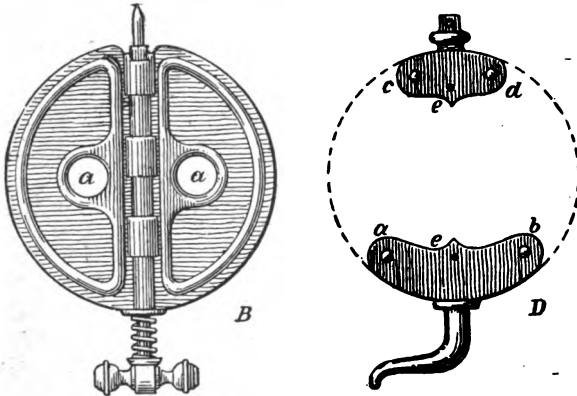

Fig. 25—Malleable Iron Damper for Smoke Pipe

malleable iron dampers for smoke pipes, the small holes *a a* allowing the coal gas to escape when the damper is closed. The rods being pointed, allow them to be driven with the hammer into the sides of the

pipe. When round dampers are made of heavy sheet iron, as shown at D, damper clips made of malleable iron are riveted to the metal disc. These have solid rivets at **a b** and **c d** and extra holes for riveting at **e** and **e**.

Wind or Blast Gates

Wind or blast gates, one of which is shown in Fig. 26, are used for closing pipes supplying blast to furnaces, forges, etc. They are also for use in exhaust

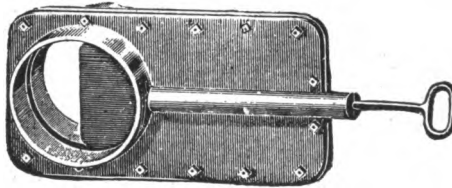

Fig. 26—A Blast Gate

or blast pipe systems, where materials of any kind, such as sawdust, shaving, cuttings or gases of any nature are to be removed, or for controlling the heated air in connection with fan systems of heating. Large ventilating dampers, usually made by hand, are also used in square ducts to control the amount of cold air entering the building.

Turnbuckles

Turnbuckles are used in hanging large, heavy sheet metal ducts. The rods are threaded right and left, so that by turning the buckle one way or the other the duct can be raised or lowered as desired.

Asbestos Paper

Asbestos paper, which usually comes in 50-lb. rolls, is used for covering hot air pipes to avoid the loss

of heat, caused by the cold air coming in contact with the surface of the pipe. It is secured to the pipes by using a paste prepared for that purpose, which can be purchased in cans.

Corrugated asbestos sheathing is also used. It covers the heating pipes, thus protecting the surface of the metal pipe from any outside air whatever. The rolls usually come in 24 and 36-inch widths. It is secured around the metal ducts by means of hoop brass, which comes in coils. This is drawn tightly over the sheathing, the ends of the hoops being locked together. It can be obtained from $\frac{3}{8}$ to 2 inches wide, and from No. 16 to No. 26 B. and S. gauge.

CHAPTER II.

SHEET METAL WORK IN HEATING AND VENTILATING SYSTEMS

Those systems of heating which require the use of sheet metal work are termed the warm air furnace, the indirect steam or hot water, the direct indirect steam or hot water and the forced blast systems.

In the warm air furnace system, galvanized sheet iron casings are placed around the furnaces, and the cold air ducts, as well as those for warm air, are all made of sheet metal. Sometimes furnaces for burning wood are used, as shown in Fig. 27, the entire casings

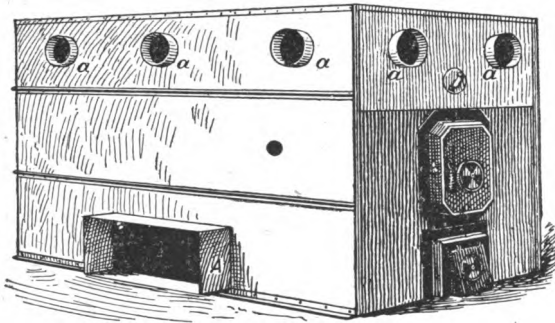

Fig. 27—Furnace for Burning Wood

being double and made portable. The cold air inlet is shown at A and the warm air outlets are indicated by a a, etc. The construction of these cold and warm air pipes and casings will be taken up in a later part of this treatise.

Sheet metal work is employed in the indirect steam or hot water heating system in the construction of a special form of heater which is placed below the ceiling and encased with No. 22 galvanized sheet iron, as shown by AA, etc., in Fig. 28. A cold air box or flue

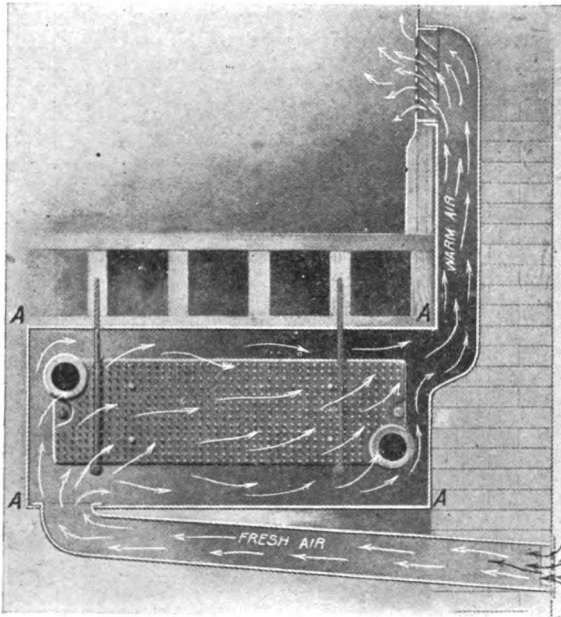

Fig. 28—Galvanized Iron Casing in an Indirect System of Heating

is connected to the bottom of the heater, as shown, and the warm air pipes at the top are connected to the registers placed in the walls or floors.

In the direct indirect heating system, the fresh air is admitted through an opening in the outside wall, as shown at A in Fig. 29, passes through the

fresh air duct B, and is heated in passing up the flues between the radiator. By raising the treadle C, the fresh air duct is closed, while the damper at the foot

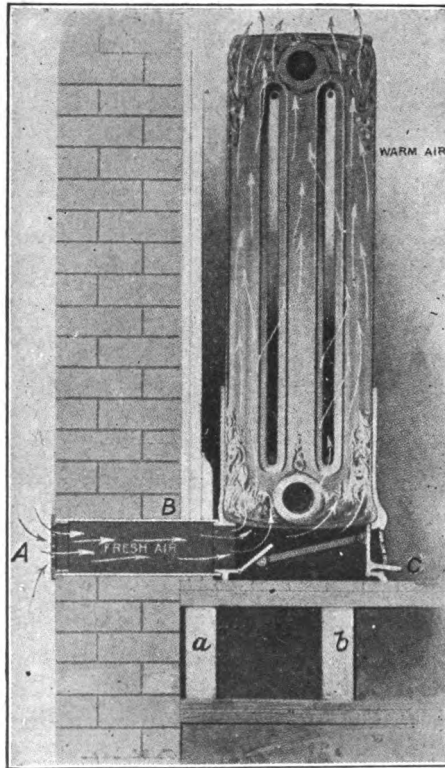

Fig. 29—Metal Duct in Direct Indirect System of Heating

of the radiator opens, thus allowing the cold air on the floor to pass up and become heated. The fresh air duct through the wall can be made of heavy sheet copper to prevent corrosion, and sometimes the space

between the beams **a** and **b** are lined with sheet metal, and the top of the fresh air duct is placed on a level

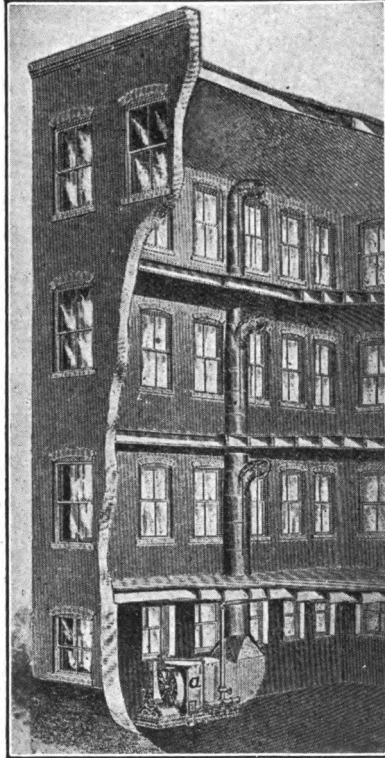

Fig. 30—Galvanized Iron Ducts in a Forced Blast System of Heating

with the bottom of the beam and connections made to the cold air box, thence through the floor to the radiator.

In the application of the forced blast for warming of factories, schools, theatres, etc., where good

fresh warm air is desired, the cold fresh air is forced through a heater of special design and discharged by a blower into ducts made of No. 22 galvanized iron, which lead to the rooms to be warmed, as shown in Fig. 30, which represents the interior of a factory. In schools, halls, etc., these ducts are placed in the walls or partitions, and discharge through registers.

Sheet Metal Ventilating Systems

Various systems of ventilation also require the use of sheet metal work in their construction. They are termed natural ventilation, heated flue or stack ventilation, heated drum ventilation and forced ventilation, consisting of the plenum and vacuum or exhaust systems.

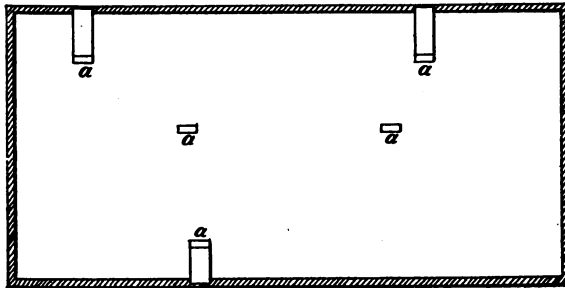

Fig. 31—Attic Plan, Showing Ventilating Pipes in Natural System

In the natural system of ventilation, the drafts in the flues or ducts are caused by the difference in density of the air in the flue or duct and that in the outer atmosphere. The higher the temperature of the air in the ducts, the greater will the draft be. The ducts are run to the attic floor, as shown by a a, etc., in Fig. 31, and the foul air is carried to the

outside by means of an ordinary ventilator. Stationary louvres may be placed instead in the gable at each end of the building if desired.

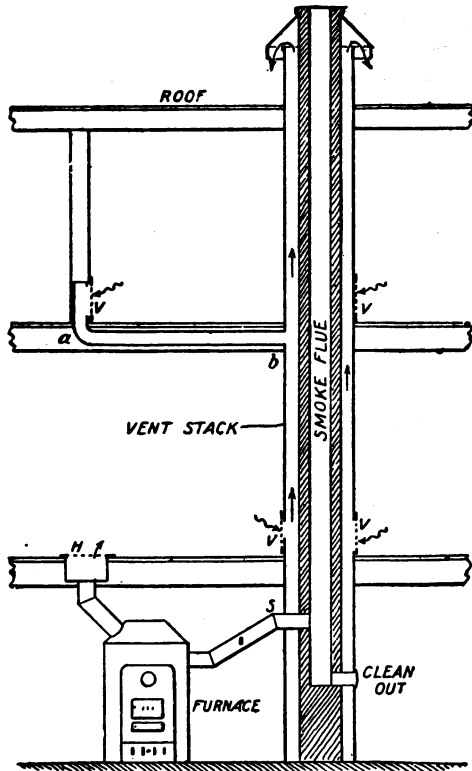

Fig. 32—Heated Flue or Stack Ventilation System

In the heated flue or stack ventilation system the smoke pipe of the furnace is connected to the smoke flue, around which a sheet metal stack is placed as shown in Fig. 32. This stack runs above the roof and is capped by a hood to keep out the rain. Ventilating

registers are connected to the stack and the heat in the flue raises the temperature of the air in the stack, which, rising, creates a suction, thus drawing out the foul air through the registers V. If desired, the registers when placed away from the stack can be connected by means of a flue or duct placed between the beams, as indicated by a b.

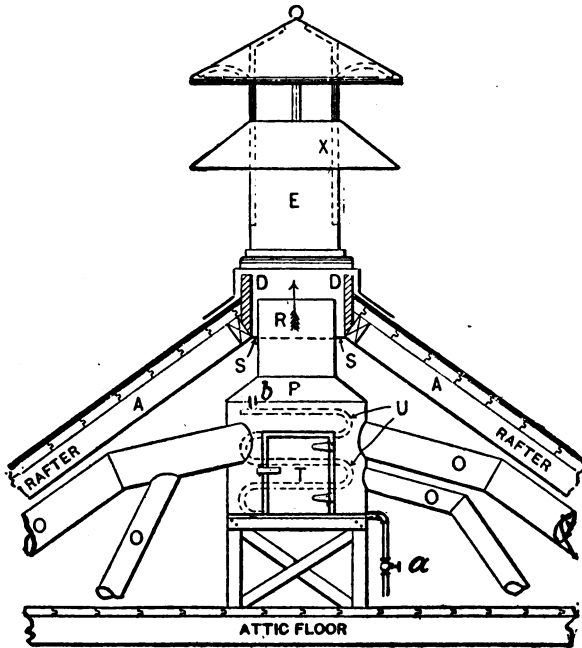

Fig. 33—Heated Drum System of Ventilation

A diagram of a heated drum ventilation system is shown in Fig. 33, in which A A show the rafters and D D the curb over which the ventilator E is secured by the braces X. A sheet metal drum made of No.

2½ galvanized iron is set upon a wooden platform, the drum being connected to the ventilator at R and made air tight at S S. A clean out door is placed at T. After the ventilation pipes O O, etc., are connected to the drum, a steam coil is placed inside of the drum with a valve at a and an air valve at b on the inside of the drum. When the steam is turned on the heated air in the drum rises and passes out of the ventilator, which creates a vacuum or suction, thus drawing out the air in the ventilation pipes O O.

There are two classes of forced ventilation: (1) The plenum system, in which the air pressure in the building is slightly greater than that of the outer atmosphere, the air being blown into the building by means of a blower placed at the inlet, as shown at a in Fig. 30. As the space in the building is filled with air under a slight pressure, the leakage is outward, thus preventing the drawing of foul air into the rooms from any outside source. (2) The vacuum or exhaust system consists of drawing the foul air from the rooms by placing an exhaust fan at the outlet to the vent ducts, which is usually run by electricity. Using this exhaust method, a partial vacuum is created within the building, and all currents and leaks are inward, because the air pressure in the building is slightly lower than that of the outer atmosphere. The plenum system is the more preferable.

CHAPTER III.

CUTTING MATERIAL, BENDING, FORMING, SEAMING, GROOVING AND BRACING

Gauge of Iron for Ducts

No. 20 gauge best bloom galvanized iron is used for ducts or flues in which one dimension is 48 inches and over. This is to be braced with $1\frac{1}{2}'' \times 1\frac{1}{2}'' \times \frac{1}{4}''$ angle iron. No. 20 gauge is used for flues and ducts of 30 inches and over, without angle iron bracing. No. 22 gauge can be used for 12 inches and over, and No. 24 gauge for the smaller sizes.

Sizes of Heat and Vent Ducts

The sizes of the ducts for given requirements are governed by the dimensions of the rooms, the number of people they will contain and the exposure presented by doors, windows and outside walls. Their areas are usually computed by heating and ventilating engineers, the sheet metal worker simply following the sizes shown on the plans.

Shapes of Ducts

Square or rectangular ducts, shown in Fig. 34, are usually employed, but sometimes, owing to the construction of the building, a triangular shape is used, as shown in Fig. 35.

The round duct, shown at A in Fig. 36, the oblong shape with semicircular ends shown at B and the oval shape C, offer the least resistance to the flow of air.

The style of seams usually employed in ducts, flues and piping is shown in Fig. 37, in which A shows a riveted seam, B a grooved seam, and C a standing seam.

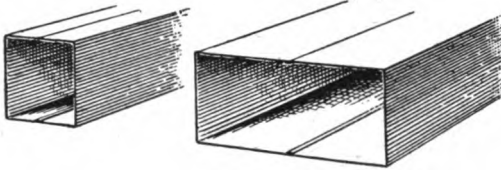

Fig. 34—Square and Rectangular Ducts

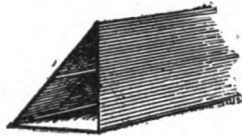

Fig. 35—Triangular Duct

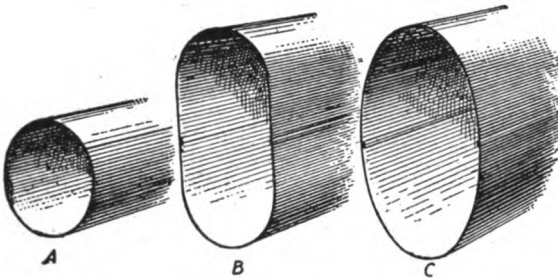

Fig. 36—Pipes Offering the Least Resistance to the Flow of Air

Cutting to Avoid Waste

Assuming that a rectangular duct must be made, say, 12×20 inches in size the seams should be so located that the metal is not cut to waste. This is shown in Fig. 38, where, by a little computation, it is found that the duct can be made from one 30 and one

36-inch wide sheet, by, usually, 8 or 10 feet long; all according to the size of brake in use. This places the seam on the wide side of the duct, $8\frac{5}{8}$ inches from

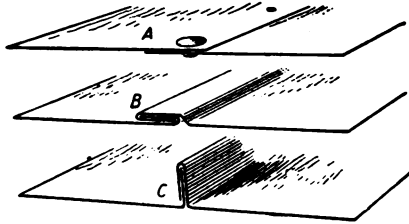

Fig. 37—Various Styles of Longitudinal Seams

one end and $11\frac{3}{8}$ inches from the other. A grooved seam is used as shown. As a $\frac{1}{4}$ -inch edge is used in

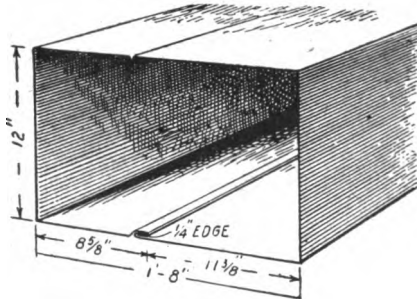

Fig. 38—Locating the Seams in Duct Work to Avoid Waste of Material

grooving, a single edge is put on the $8\frac{5}{8}$ -inch side and a double edge on the $11\frac{3}{8}$ -inch side.

Prick Marking the Sheets

The sheets are prick marked for bending in the brake by means of a narrow strip of metal, say $\frac{1}{2}$ -inch wide. It is cut 30 inches long, as shown in Fig. 39, and the measurement laid out thereon as shown. This allows for a single $\frac{1}{4}$ -inch edge, making a total

of $29\frac{3}{4}$ inches. As the sheet is 30 inches wide, it is trimmed straight and true on the large squaring shears to its desired width of $29\frac{3}{4}$ inches. Then the

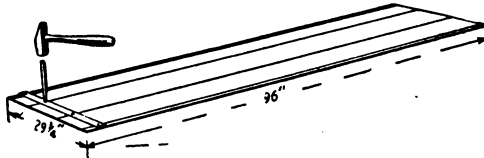

Fig. 39—Locating the Brake Marks

strip is laid on at each end of the sheet, and by means of the prick punch and hammer the prick marks shown are put into the metal sheet.

Preparing the Marking Strip

The marking strip is prepared for the double edge as shown in Fig. 40. Here a single edge of $\frac{1}{4}$ inch is

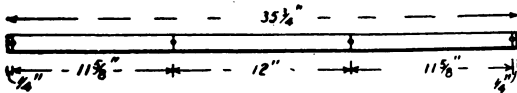

Fig. 40—Allowing for the Double Edges

allowed, as shown by the prick marks, but the extra $\frac{1}{4}$ inch has been added to the $11\frac{5}{8}$ inches shown in Fig. 38, as indicated by $11\frac{5}{8}$ inches in Fig. 40. This gives a total of $35\frac{3}{4}$ inches, which allows the 36-inch

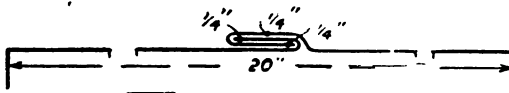

Fig. 41—Extra Material to Be Added in All Grooved Work sheet to be trimmed straight on the large shears. From the foregoing it will thus be seen that the extra material for each seam to be added to the width of

the pipe in all grooved work is three times the width of the lock. Thus, if the pipe is 20 inches wide, as shown in Fig. 41, and the locks are to be $\frac{1}{4}$ inch, then add three-quarters of an inch to the width of the pipe, making the girth of the side $20\frac{3}{4}$ inches.

Bending the Ducts

Fig. 42 shows the sectional views of a brake in which A represents the top clamp and A¹ the bend-

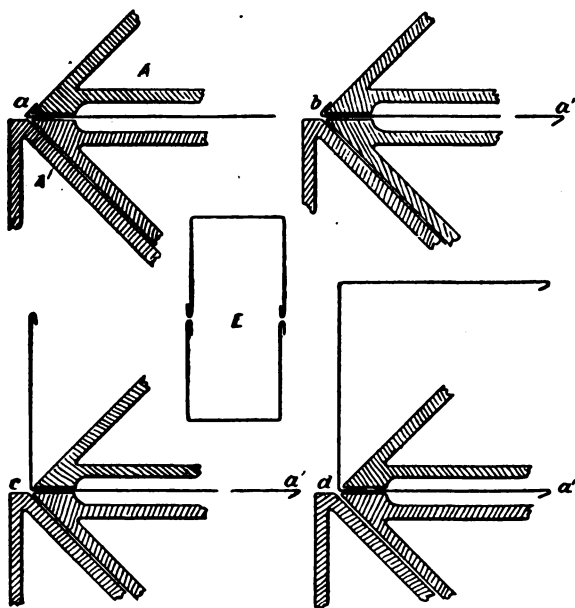

Fig. 42—The Various Operations in Bending the Ducting leaf. The sheet is placed in the brake and the top clamp closed on the first prick mark; then by raising the bending leaf A¹ the edge a is bent. The sheet is now reversed, as shown by the second diagram, and the block b bent in a similar manner. Leav-

ing the sheet still in the brake it is drawn out to the next prick mark *c*, as shown in the third diagram, and a square bend is made. Again drawing out the sheet to the next prick mark a square bend is made as shown at *d*. Thus it will be seen that the sheet is reversed but once, when the locks are bent right and left. Bearing it in mind to always bend the locks right and left, the duct will always be in proper position for grooving, as shown in diagram *E*.

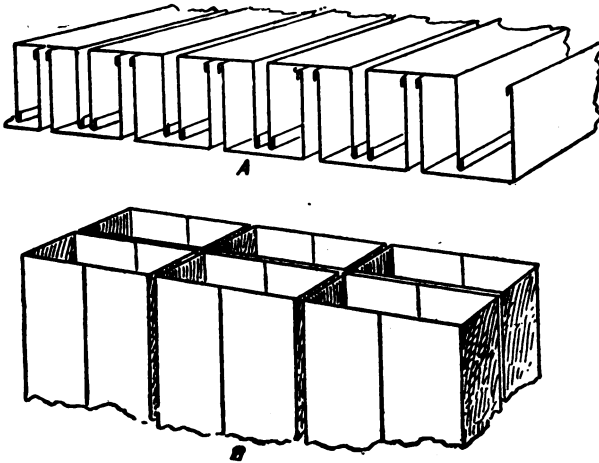

Fig. 43—Method of Transportation

Grooving the Ducts

If large power groovers are in use, it is an advantage to groove the ducts in the shop, owing to the saving in time and labor; if, however, they are to be grooved by hand on a grooving bar, it is an advantage to do the work at the job, because the saving in transportation on a large job will be quite an item, es-

pecially when the job is at a distance from the shop. When the ducts are grooved on the job, the partial ducts are nested in transportation, as shown at A in Fig. 43, while if the ducts are finished in the shop, but a few of the larger sizes could be carted at one time, as shown by B.

A grooving bar made of a steel rail, as shown in Fig. 44, is used for outside work. To make one obtain a section of a car rail and have the flat side planed smooth by a tool maker, and a channel A cut in to suit the edges or locks bent on the sheet metal. The rail should be about 12 feet long, with the channel cut in about 9 feet, this being figured for an eight-foot sheet of iron.

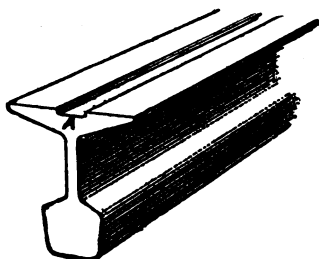

Fig. 44—Grooving Bar or Rail

As shown in Fig. 45, the grooving bar is set upon a wooden trestle, or support, B, of a height to suit the size of pipes to be made. A shelf, located at C, is to hold any necessary tools and keep them from getting lost about the building. A brace D is set over the rail and under the ceiling, so that the rail is level, and braced as shown at a and a, stops being used at b and b. To prevent the rail from wobbling additional braces, not shown, are fastened at X and X. An additional support, E, may also be

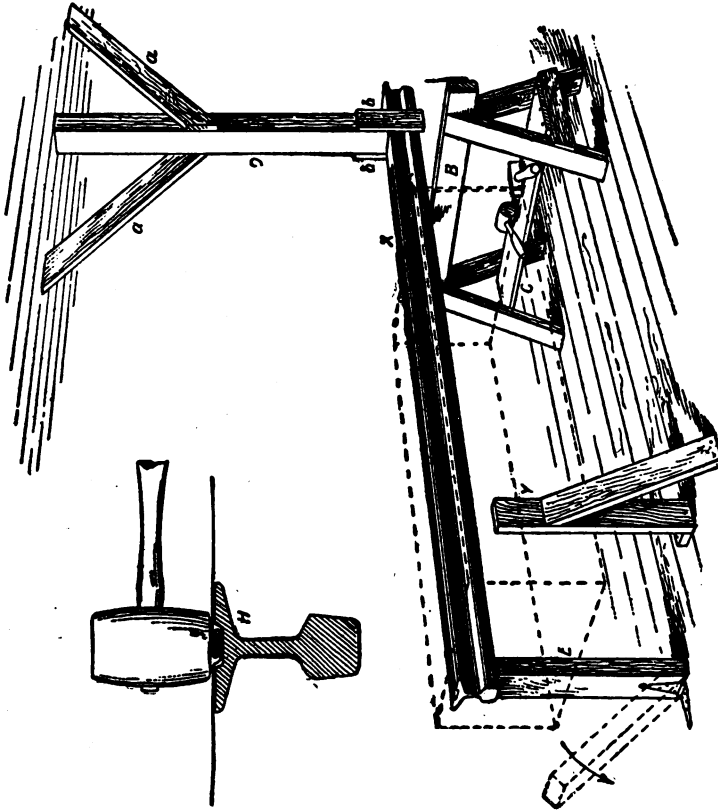

Fig. 45—Method of Using Grooving Bar

hinged to the floor, as shown, thus allowing it to fall to the floor when not in use. When grooving the duct, set up the brace E, set the locks of the duct over the groove in the rail, tap each end with the mallet, to keep it from slipping; then, by means of mallets in the hands of two men, one on each side of the bar, mallet down the seams. This will make a smooth surface on the outside, as shown at H. When a large quantity of ducts are to be made, a gauge is constructed by means of four braces, one of which is indicated by Y, two being on each side. The distance between the inside of the braces is made to equal the required width of the ducts. This saves time in grooving, as it is only necessary to

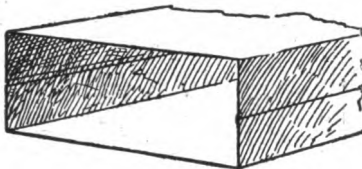

Fig. 46—Full Area

slide the pieces between the braces, when the locks will come directly over the groove, ready to be malleted down.

Bracing the Ducts

The bracing and construction of ducts should be such that the full area of the duct will be maintained, as shown in Fig. 46, and not give the surfaces a chance to buckle inward, as shown in Fig. 47, which decreases the area, as shown at A. The small size ducts are braced as shown in Fig. 48. The band iron which secures the sheets in a bundle can be

used for this purpose. A flange of $1\frac{1}{2}$ inches at each end is riveted to the pipe at *a* and *a*, the flat way of

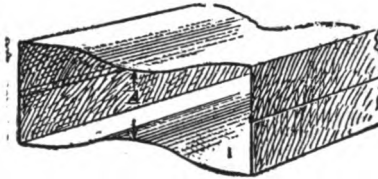

Fig. 47—Decreased Area

the band running parallel with the duct, so as to offer the least resistance to the flow of air. Ducts

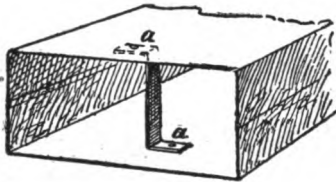

Fig. 48—Bracing Small Ducts

which are 30 inches in width and over, but still not wide enough to receive angle iron bracings, are

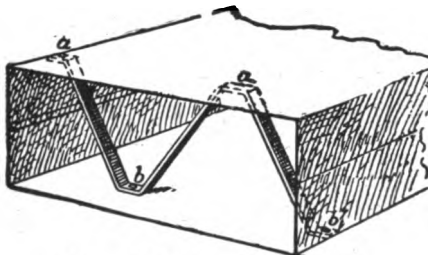

Fig. 49—Diagonal Bracing

braced by means of diagonal bracings, as shown in Fig. 49. These braces are made from band iron, not

less than 1 inch wide and $\frac{1}{8}$ inch thick, and are riveted to the duct at **aa** and **bb**. Flues or ducts which have a dimension greater than 48 inches are braced by means of angle iron frames, spaced not over 4 feet apart, as shown in Fig. 50. With this construction no diagonal bracings are required, as the angle iron frames keep the duct true and rigid.

Angle Iron Frames

These angle iron frames are laid out as shown in Fig. 51, where two methods are shown. In the first,

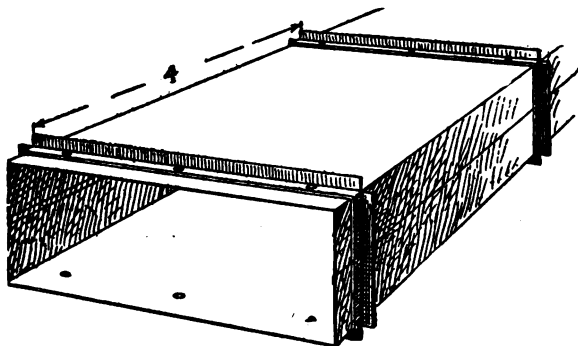

Fig. 50—Angle Iron Bracing and Stiffeners

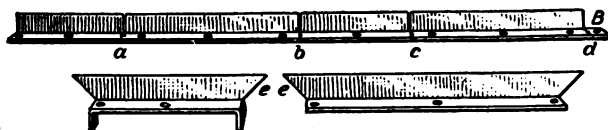

Fig. 51—Preparing the Angles Previous to Bending

in which the corners remain open, the notches are made with the heavy slitting shear, where the corners will be bent, as indicated by the center punch marks at **a b c** and **d**. A flange is allowed at **B** for

joining at one corner. All holes should be punched before bending. The second method, in which the corners miter, is shown below. In this case each side of the angle iron frame must be cut separate, and each leg mitered as indicated by *e* and *e*. Flanges are allowed on the two opposite sides for riveting, as indicated. The first method is preferable and much quicker, and is rigid enough, even though the corners show open as indicated in the previous figure.

Large Size of Ducts

The construction known as longitudinal and horizontal bracings, shown in Fig. 52, are used on spe-

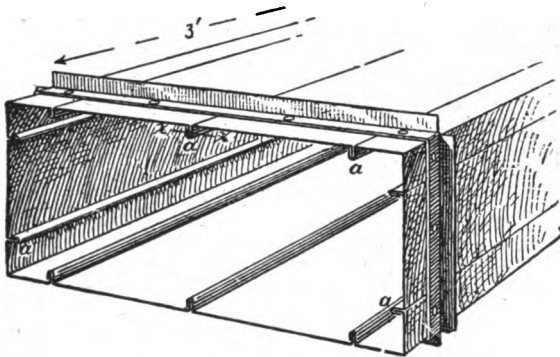

Fig. 52—Longitudinal and Horizontal Bracing

cially large sizes. In this construction the widths of the sheets are carefully computed to avoid any unnecessary waste, and the longitudinal joints, made like standing seams, as indicated by *a a*, etc. These seams are tightly closed and riveted at intervals, as indicated at *x x*. In addition to this, angle iron bracings, spaced about 3 feet apart, are riveted on the outside of the duct, as indicated. This gives a first-

class rigid construction for exhaust and heat ducts, the standing joint on the inside causing hardly any resistance to the flow of air.

Ducts with Outside Seam

When it is desired to have the standing seam on the outside of the duct, it is braced by placing the angle iron frame on the inside of the duct, as shown in Fig. 53, the angle frame being indicated by *a*. As the area of the duct is decreased by the placing of the angle on the inside, care must be taken to enlarge the duct, so that the inner opening of the

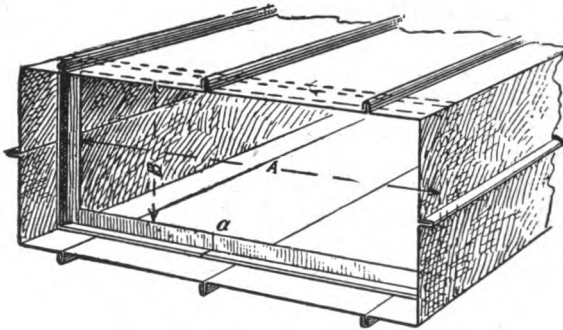

Fig. 53—Standing Locks Outside

angle iron frame shown by *A* and *B* will have dimensions to correspond with the area required.

Other Flues and Ducts

Standing joints are also used on square duct work in which the sheets can be used to advantage by seaming the corners and riveting through *a b*, as indicated in Fig. 54. This standing joint, bent on the diagonal of the duct, gives great rigidity and strength to the entire run. When vertical flues are to be

placed inside of enclosing shafts, the shafts to be lined in sections, the joints are made by using longitudinal cup joints, as shown in Fig. 55. This joint

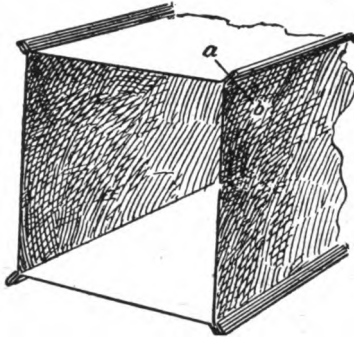

Fig. 54—Duct With Corner Seams

clamps and holds firmly. Special care must be taken that the distance between the inside of the flange b and the outer edge of the flange a is not any more

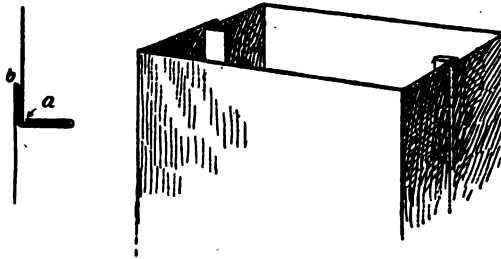

Fig. 55—Longitudinal Cup Joint in Shaft Work

than the thickness of the metal used will allow, so that both parts will slide tightly, but easily into place.

Bending Cup Joint in Brake

This cup joint is bent in the brake, as shown in the various operations of Fig. 56, in which the bends

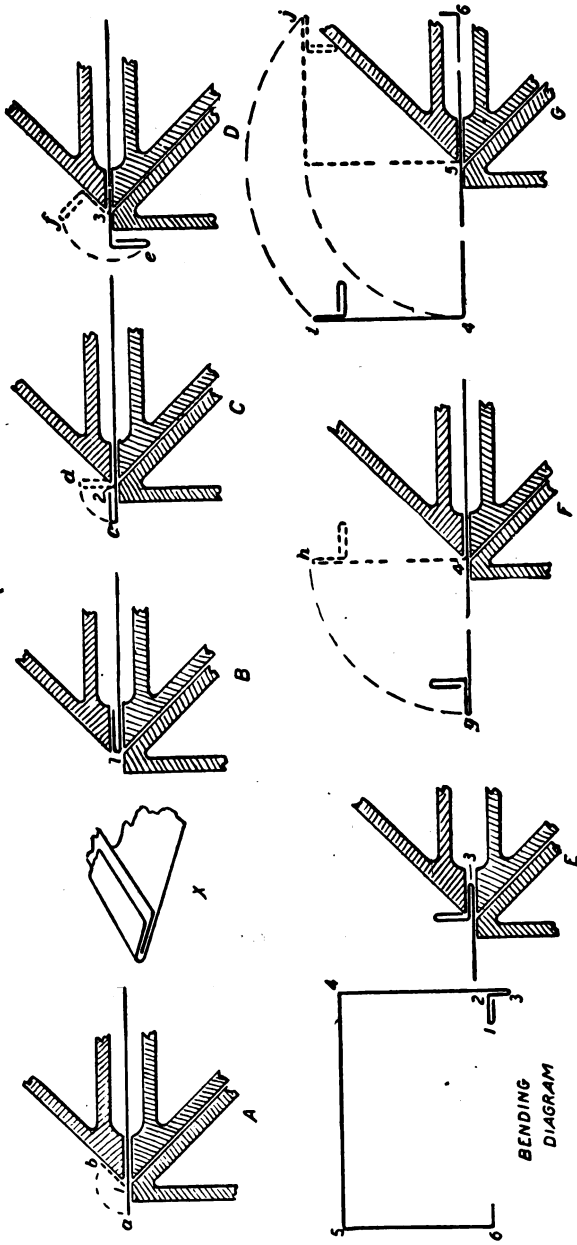

Fig. 56—The Operations Required in Bending Longitudinal Cup Joint

are numbered from 1 to 6. The first operation is shown in diagram A, in which the top clamp is closed on dot 1, and the edge a turned over as far as the bending leaf will turn it, as shown by b. The jaws of the brake are then opened and the edge is placed between same, when by slowly but firmly closing the top clamp as shown in diagram B, the lock 1 is produced. Care must be taken not to completely close the lock, and if the operator is in doubt about doing this correctly, a strip of iron slightly thicker than the metal in use is previously laid into the lock, as shown in X. This prevents the lock from being closed entirely. The lock 1 in B is now drawn out and the top clamp closed on dot 2, as shown in C and a square bend made, as shown, from e to d. The metal sheet is then reversed and the top clamp closed on dot 3 in D, and e is turned over as far as the bending leaf will turn it, as shown by f. The bend 3 is now closed tight, as shown in E, the sheet placed in the brake, as shown in F, and the top clamp closed on dot 4 and a square bend made as indicated from g to h. The next bend in order is 5, but before this bend is made, bend 6, shown on the bending diagram, should be made. If the jaws of the brake are not wide enough to admit the edge turned at 6, the top clamp is raised and the edge 6 is placed between the jaws of the brake and the top clamp is closed on dot 5, as in G, and a square bend made. This completes the bending of the cup joint.

Exhaust Ducts for Acid Fumes

In large buildings, where electrical plants are in operation, provisions must be made to carry off the fumes of sulphuric acid from the battery rooms. Any

metal, such as iron, tin, brass or copper, would be destroyed by the acid fumes, so that experience has shown that sheet lead is the best metal to use. The duct is constructed as shown in Fig. 57, in which

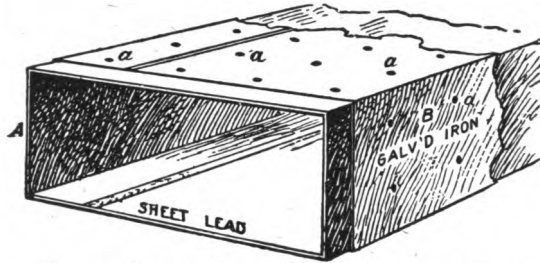

Fig. 57—Exhaust Duct for Battery Fumes

B is a heavy galvanized iron duct, having one-half-inch holes punched at intervals as indicated by a, a, a, etc. Inside of this galvanized iron duct a sheet lead lining A is placed, made of 3-16-inch thick sheet lead, and secured to the galvanized iron duct by soldering through the perforations at a, a, etc.

Precautions in Soldering

In order to avoid burning holes in the sheet lead it must first be scraped bright and clean, then a wooden or other brace, is placed on the inside of



Fig. 58—Soldering the Sheet Lead to the Galvanized Iron

the duct to keep the sheet lead from sagging. "Killed" acid is used as a flux, and is applied with a small brush. By using the soldering copper the solder is sweated in between the two metals, as shown in Fig.

58, in which the black portion between the two metals represents the hole punched into the galvanized iron. The shaded portion represents the solder, which has been sweated between the two metals, while the button on the galvanized iron represents the amount of solder which should remain, to insure a good stiff hold. The soldering copper should not be too hot, otherwise holes will be burnt into the sheet lead. Experience will show when the copper has the right temperature, and it is well to have a scrap piece of sheet lead handy, on which the copper can be tried. If the solder used is composed of 50 per cent. each of tin and lead, it will melt at 370° F., while sheet lead requires 621° F. Thus with a little experience in soldering one will become proficient.

Preparing "Killed" Acid

To prepare "killed" acid, take any glass or earthenware dish and fill it one-fourth full with muriatic acid. Then use small clippings of clean zinc, and drop in one after another, when bubbles of gas will arise. The quantity of zinc required is determined when the acid stops boiling. The acid has now become chloride of zinc, and it is strained through a linen cloth and kept corked in a bottle for future use.

CHAPTER IV.

CONSTRUCTING THE VARIOUS SLIP JOINTS

A formation in sheet metal, which makes the horizontal slip joint between square, triangular or rectangular ducts, is known as a "slip."

When the pipe or duct is round or elliptical, an ordinary slip joint is made, as shown in Fig. 59;

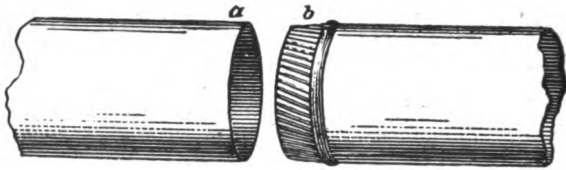

Fig. 59—Slip Joint in Round Ducts

that is, by the end of the one pipe slipping over the crimped part of the lower one, as shown by a and b. When the ducts are square, triangular or rectangular, the most simple slip in use is the S slip, shown in Fig. 60. In addition to these the following slips are used: the riveted S slip, the punched S slip, the wired edge slip, the flat slip with duct edges wired, the re-enforced slip with outer edges beveled, the re-enforced standing edge slip, the doubled edge flat slip, the sheet metal angle slip, the re-enforced angle iron slip, the expansion slip joint and the double angle iron butt joint.

Preparing End of Duct for Slip

There are two methods of preparing one end of the duct previous to fastening the slip on same. One is to notch the corners down as wide as the slip will

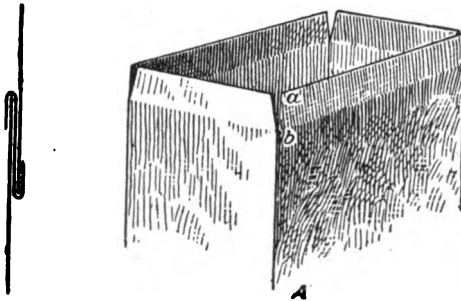

Fig. 60—Ordinary S Slip

be, which is usually about two inches, as shown from a to b in diagram A of Fig. 60; the other is to use the pean of the hammer and turn an inward groove

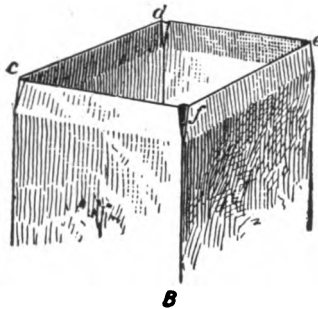

Fig. 61—Preparing the Ducts for Receiving the Slips

on each corner, as shown in diagram B by c, d, e, and f, in Fig. 61. The second method is recom-

mended because no notching is required and rigidity is given to the corners.

Uses of a Dolly

A dolly similar to that shown by A in Fig. 62 can be used to advantage to make the inward groove on each corner of the duct. It contains a tapering groove in one corner, as shown. In using same, the dolly is

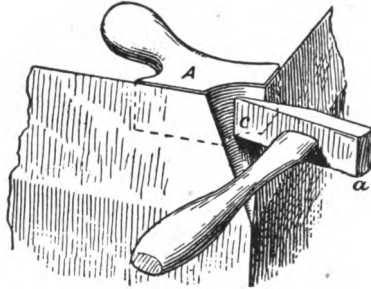

Fig. 62—Putting Groove in Corner

held by the handle in the left hand, is pressed firmly against the inside corner of the duct, and, by means of the face of the hammer a, the corner is slightly flattened; then, with the pean c, the groove is worked into the dolly, in sufficient depth to give the lap the required taper so as to allow the next point to slip over easily.

Cutting the Tapered Ends

In cutting the tapering ends of the slip, the length indicated by A in Fig. 63 should be $\frac{1}{8}$ inch less than the length of the side of the duct on which the slip is to be placed, B should equal the width of the

notch *a*, *b* in Fig. 60, or the tapered groove *f* in Fig. 61, while the length at *C* in Fig. 63 should be $\frac{1}{8}$ inch less than *A*.

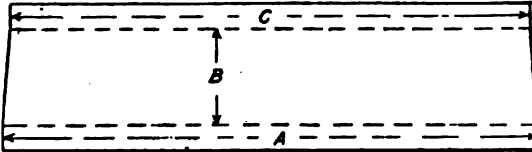

Fig. 63—Pattern for Slip

Fastening the Riveted Slip

The riveted S slip shown in Fig. 64 is hooked over the tapering end of the duct and riveted as shown at *c* in the diagram at the right, after which the straight end of the duct *B* slips into the outer hook, as shown. The cut at the left shows the end of the duct with slips riveted on four sides.

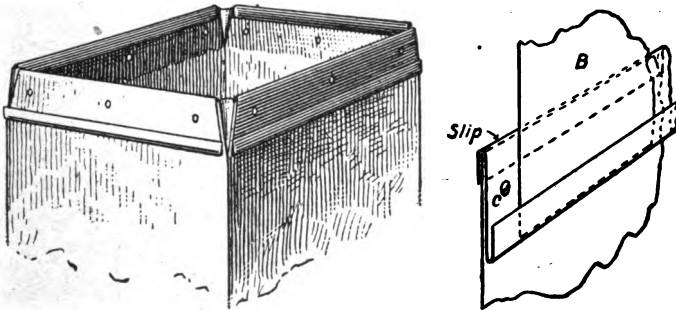

Fig. 64—Applying the Riveted S Slip

Applying Punched S Slip

After the slip has been hooked over the lower joint, the S slip may be secured by punching, as shown in Fig. 65. Triangular holes are punched into the slip and lower joints, as shown. This binds the slip

and keeps it from moving, the slot being covered by the upper joint.

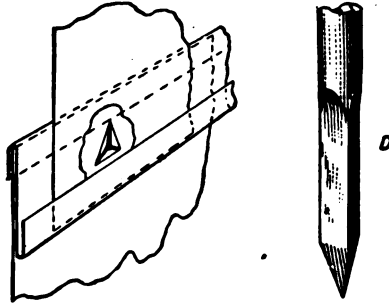

Fig. 65—Applying the Punched S Slip

In punching these slots a three-cornered punch is used, as indicated at D, each side of which measures about half an inch. In using the punch, a block of

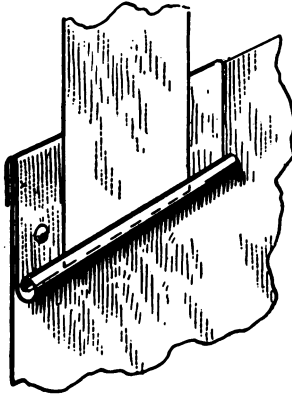

Fig. 66—Slip with Wired Edge

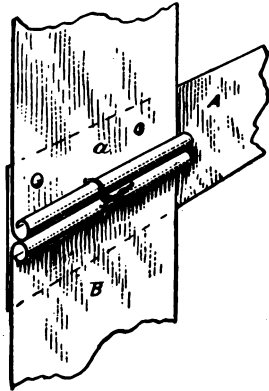

Fig. 67—Flat Slip with Duct Edges Wired

wood or cake of lead is held on the inside and holes are then punched about 12 to 15 inches apart.

Wire Edge Slip

The wire edge slip is made with a hook on one side and a wired edge on the other, as indicated in Fig. 66. This slip can be riveted or punched and the upper joint dropped behind the wired edge. When the ends of the ducts are wired, a flat strip of metal, indicated by A in Fig. 67, is riveted to the end of one of the ducts, as shown at a, after which the lower duct B is slipped over same. This method avoids the notching of one end of the duct. Sometimes the wired edges are fastened together by means of soft brass wire. By using a long, thin prick punch holes

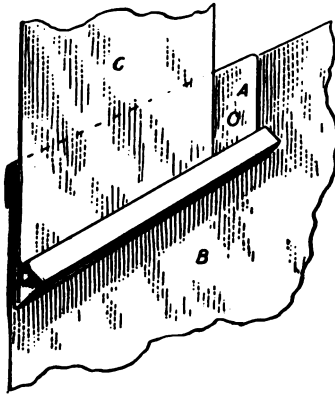

Fig. 68—Beveled Edge Slip

are punched through the duct and slip as shown, and the wire is twisted on the outside as indicated.

Beveled Edge Slip

The beveled edge slip has a formation similar to that shown in Fig. 68 at A. It is slipped over the lower pipe B and riveted, the upper duct C slipping

on the inside of the slot. This form of slip makes a rigid construction, keeps the shape of the pipe true at the cross joints and prevent it from sagging.

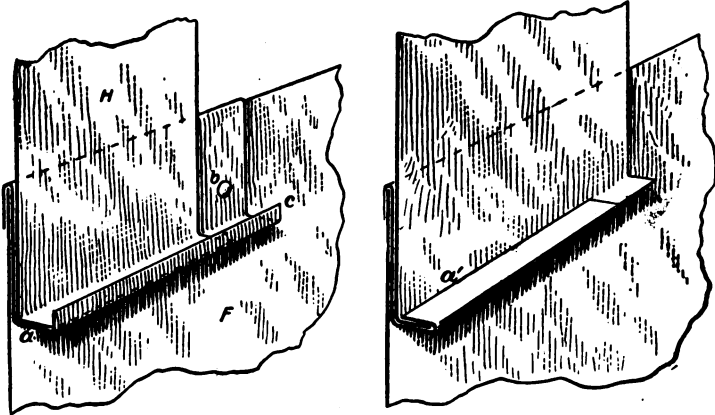

Fig. 69—Standing Edge Slips

Re-enforced Standing Edge Slip

The re-enforced standing edge slip is shown in detail in the two views in Fig. 69, in which the slip *a*, of the first diagram, is formed as shown, and riveted to the duct *F* at intervals, as at *b*. The end of the other duct *H* has an outward flange, which rests upon *a*, after which the edge *c* is turned over, all as shown in the second diagram at *a*.

Double Edge Flat Slip

The doubled edge flat slip is formed and applied as shown in Fig. 70, in which *A* shows the formation of the slip, with double locks, as indicated by *a* and *b*. By using this form of slip for small size ducts, no notching is required, as the slip *A* hooks over the duct

B and is riveted through the three thicknesses of metal, as at c. The upper duct C then slips in at b.

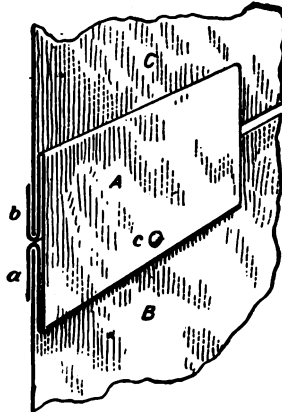

Fig. 70—Double Edge Flat Slip

Sheet Metal Angle Slip

In Fig. 71, A shows the formation of the sheet metal angle slip. When forming this slip on the brake,

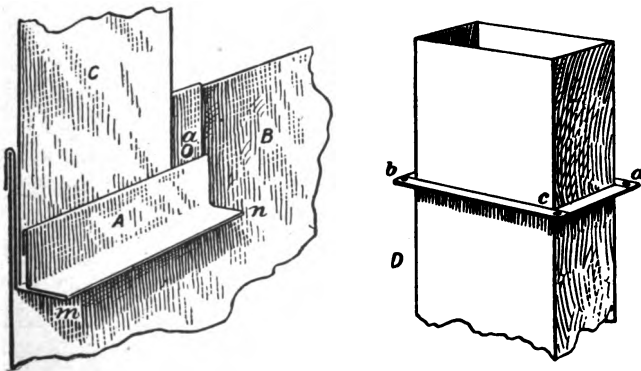

Fig. 71—Sheet Metal Angle Slip

the bend along *m n* is clamped the very last on the brake. The slip is riveted to *B* along *a*, after which *C* slips in behind the groove in the slip, as shown. When the cross joints are made in this manner, the angle slip forms a stiff brace, as shown in diagram *D*, at the right, which can be further strengthened by lapping and riveting the corners, as shown by *b c d*.

Angle Iron Slip

The re-enforced angle iron slip is shown in Fig. 72. The slip is formed similar to that in the previous construction, excepting that an angle iron is inserted, as shown at *C*. The slip is hooked over *B*, riveted through, and *D* dropped into the groove behind the angle iron, as shown. This method forms a rigid construction, which can also be treated at the corners, as in the previous case.

Expansion Slip

An expansion slip joint is one that allows for the expansion and contraction of the sheet metal when gauges heavier than No. 20 are used. It is used on heating ducts, which are usually placed along the ceilings in the basement, which supply the uptakes made up of lighter gauge metal. The method of constructing this expansion slip joint is shown in Fig. 73, in which *A* and *B* represent the ends of two joints of the duct. On the end *A*, using metal having the same gauge as the duct, strips are riveted, as indicated by *a* and *b*, and over *a* the angle iron *c* is placed flush with the edge of the sheet *A*. These four thicknesses, namely, the inner strip *b*, the sheet *A*, the outer strip *a* and the angle iron *c*, are carefully punched and riveted at intervals of about 10 inches,

as at d. The inner strip b is made wider than a, so that the joint can easily be slipped into place.

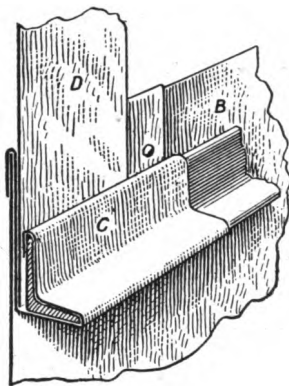

Fig. 72—Re-enforced Angle Iron Slip

Care must be taken in slipping the joints together. By having the strip b wider than a, the duct B can be first slipped over b, then pressed forward under

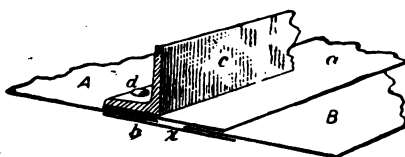

Fig. 73—Expansion Slip Joints for Heavy Metal Ducts

a, but not so closely that the distance between the edges of the sheets A and B will be less than $\frac{3}{8}$ of an inch, as indicated by point x. Sometimes an angle is riveted on the duct B, to prevent it from slipping in too far. This will allow the sheets to expand when they become heated, or contract when cooled. If

they were brought tightly together, there would be no chance for expansion when the metal becomes heated.

Angle Iron Butt Joint

The double angle iron butt joint for heavy duct work is constructed by means of two angle irons, each

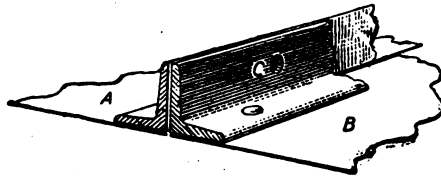

Fig. 74—Horizontal Joints by Means of Angle Iron Connections

riveted to the ends of the sheets A and B, as in Fig. 74. The angle irons are then riveted or bolted together through the holes which have been previously punched, as at C.

CHAPTER V.

HANGING CEILING DUCTS—SUPPORTING AND FASTENING DUCTS

Hoisting

After the ducts are made up complete in 8 or 10-foot lengths, ready for joining, if of light weight, they are raised to the different stories in the building by being handed up from one floor to another, through the well holes; if, however, the ducts are heavy, they are raised by means of a rope, fastened as shown in Fig. 75. The loop A is first made, then the rope looped and turned so as to bring it in the position shown by B. This method of tying keeps the duct in an upright position while being hoisted.

Hanging

In hanging the heat and vent ducts to the ceilings, when the beams are of wood or iron, for the lighter weight ducts band iron straps and wire are used, but for the heavier weight ducts band iron hangers are used, and where the heat ducts are required to have a slight incline, turn buckles are used in connection with band iron hangers. On wooden beams the hangers are simply nailed, while on iron beams, clamps are used to fasten them to the flanges of the I beam.

The light weight duct, when the beams are of wood and run parallel with the duct, is hung as indicated in Fig. 76. Straps of band iron $\frac{1}{8}$ inch thick and 1 inch wide of sufficient length are bolted about

64 *Hanging and Supporting Ducts*

3 feet apart to the sides of the duct, as shown. Stove bolts $\frac{1}{4} \times \frac{3}{4}$ inch pass through the outside, as at *a*, with the nut on the inside, as at *b*. When these straps have been bolted in position, the duct is raised to the bottom of the beam and nailed on both sides,

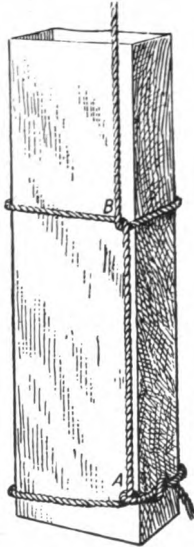

Fig. 75—Tying the Rope Previous to Raising the Duct to the Upper Stories

as at *c*. After the ducts are hung, furring strips are nailed around the outside of the duct, as shown in Fig. 77, then lathed and plastered, or furred and metal ceiled. When the building is of fireproof construction, the furring is done by using light angle iron, covered with wire mesh and plastered. In the illustration, *A* is the furring, *B* the lath and *C* the plaster. It is usual to make the interior angle in the form of a cove, as shown by *a*, and the exterior angle a

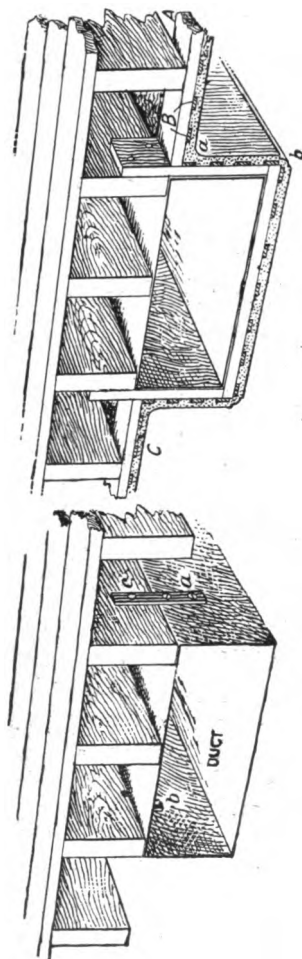

Fig. 77—Method of Finishing With Plaster, Around the Ducts Hung on Ceiling

Fig. 76—Hanging Light Weight Ducts Along Ceiling, to Wood Beams, When Beams Run Parallel to Duct

66 *Hanging and Supporting Ducts*

chamfer, as indicated by b, thus avoiding sharp corners.

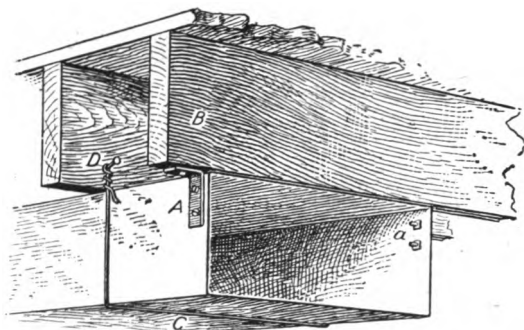

Fig. 78—Hanging Lightweight Duct, When Wood Beams Run at Right Angles

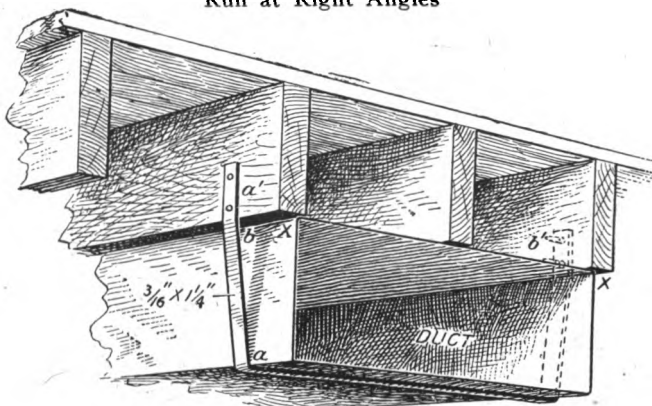

Fig. 79—Hanging Heavyweight Duct With Steel Bands, When Beams Run Parallel to Duct

Hanging Light and Heavyweight Ducts to Wooden Beams

The lightweight ducts, when the wooden beams run at right angles to the line of the duct, are hung

by bolting band iron angles to the sides of the duct, as shown by A in Fig. 78, fastening the nut on the inside as at a. These angles must be bolted in their correct positions so as to meet the beam B, to which they are nailed. Sometimes, when the duct is small, galvanized iron wire C is placed around the duct and nailed at D.

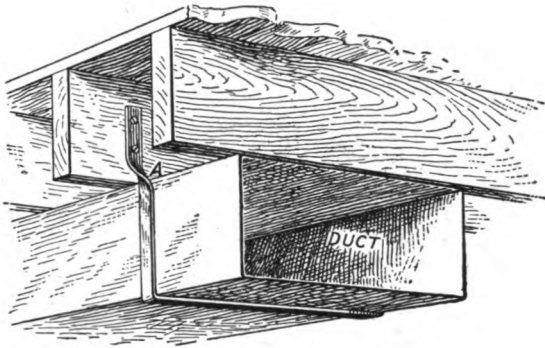

Fig. 80—Hanging Heavyweight Duct, When Wood Beams Run at Right Angles to Line of Duct

When the duct is heavy and the wood beams run parallel to the duct, the hangers used to support the duct are of band iron, bent as shown in Fig. 79, of the size there indicated. In this case the duct is propped up against the ceiling, the hanger put in position and nailed at a' and b'. This style of hanger requires no bolts in the duct.

When the ducts do not come even with the sides of the beam as at X and X, the hanger is bent at an angle, as required and as indicated, from a to b.

When heavyweight ducts are hung to wood beams, running at right angles to the line of the duct, a hanger is used similar to the previous one, except-

68 *Hanging and Supporting Ducts*

ing that a twist is made at A, in Fig. 80, to allow the band iron to be nailed against the beam.

Hanging Light and Heavyweight Ducts to Iron Beams

When lightweight ducts are to be fastened to iron beams, running parallel with the line of the duct, they are to be hung as shown in Fig. 81. When the

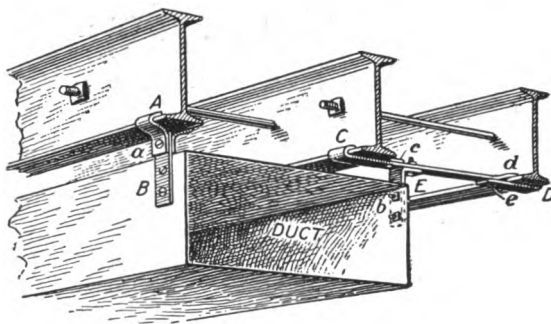

Fig. 81—Hanging Lightweight Duct, When Iron Beams Run Parallel to Duct

width of the duct brings its sides to the center of the beam, a clamp is made as shown by A, which clasps the bottom flange of the iron beam; then after the strap B has been bolted in position to the side of the duct, the duct is raised and a bolt a passed through the clamp and strap. Should the dimensions of the duct be such as to bring one side to the center of the beam, and the other side between the two beams, as shown in the illustration, then, to prevent sagging, a portable clamp is made of heavy band iron in parts, from C to d, e to D and c, as shown, the clamp being bolted at c and e. The angle

strap E is first bolted to the side of the duct at b, then to the clamp at E. The clamps are made com-

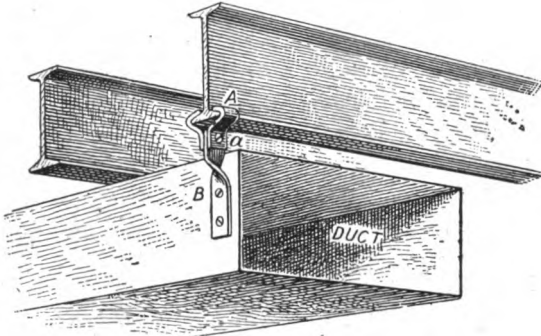

Fig. 82—Hanging Lightweight Duct, When Iron Beams Run at Right Angles to Duct

plete in the shop, except that the hole at E is punched at the building to suit the location.

When the iron beams run at right angles to the

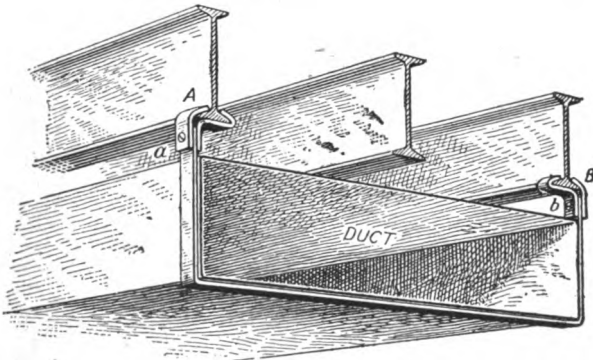

Fig. 83—Hanging Heavyweight Duct, When Iron Beams Run Parallel to Duct

line of the duct, the lightweight ducts are hung by using a clamp similar to the one shown in the previous

70 *Hanging and Supporting Ducts*

figure, but shown more clearly by A in Fig. 82, the side strap B being twisted as shown and connected to the clamp at a.

When the ducts are of heavy weight, and the beams run parallel with the duct, and the dimensions of the duct are such as to bring an equal space on either side of the beams, the clamps and hangers are made as shown in Fig. 83. The clamps are bent as shown by A and B; the hanger goes around the three sides of the duct and is bolted at a and b.

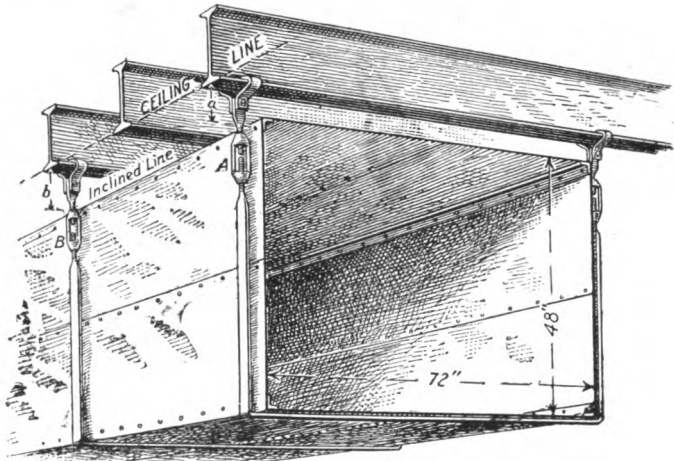

Fig. 84—Hanging Heavy Metal Heat Duct on an Incline Using Turnbuckle Hangers, When Iron Beams are at Right Angles to Duct

Assuming that the iron beams run at right angles to the line of the duct, and that large, heavy metal heat ducts are to be hung on an incline from the basement ceiling, the ducts, if as large, say 4 ft. by 6 ft., are riveted together and the corners re-enforced by angle irons, as shown in Fig. 84. Clamps are

fastened to the iron beams, and hangers provided, with turn buckle attachments which can be adjusted to A and B, as desired, thus bringing each hanger in its proper position to give the desired pitch to the duct, as indicated at a and b.

In large public buildings, such as schools, etc., where a number of runs of ducts must be suspended from the ceiling, the iron worker, knowing the height

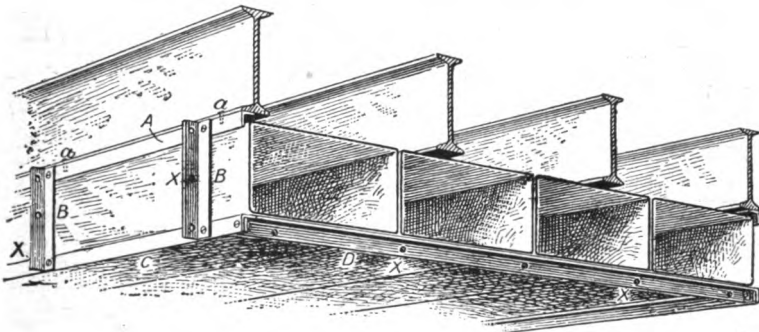

Fig. 85—False Ceiling, Constructed of Angle Iron, for Supporting Runs of Ventilation Ducts in Fireproof Buildings

of the ducts, usually constructs angle iron supports, as shown in Fig. 85, upon which the ducts are laid. The angle iron A is bolted to the flange of the beam at a and a, then by means of the straps B, the supporting frame, shown by C and D, is secured. The holes, shown by X, X, etc., are used to fasten on the wire mesh or metal lath to which the plaster is secured.

Supporting Ducts in Attic

When a number of exhaust ducts are carried to the attic, to be connected to the exhaust fan chamber, the ducts should not be placed one over another, as shown at N in Fig. 86. This tends to bulge the

lower ones, thus reducing the exhaust area of the ducts. The iron worker should bolt cross angles to the rafters A, A, A, as indicated by a, b and e, f, and partially shown at c, d, h and i, thus giving separate support for each run, numbered from 1 to 5 in the illustration. The T irons m, n and o are for the support of the fireproof blocks for the roofing.

Securing Vertical Runs of Ducts Against Walls

Heating and ventilating uptakes, when they are placed in a recess in the wall, are fastened by plac-

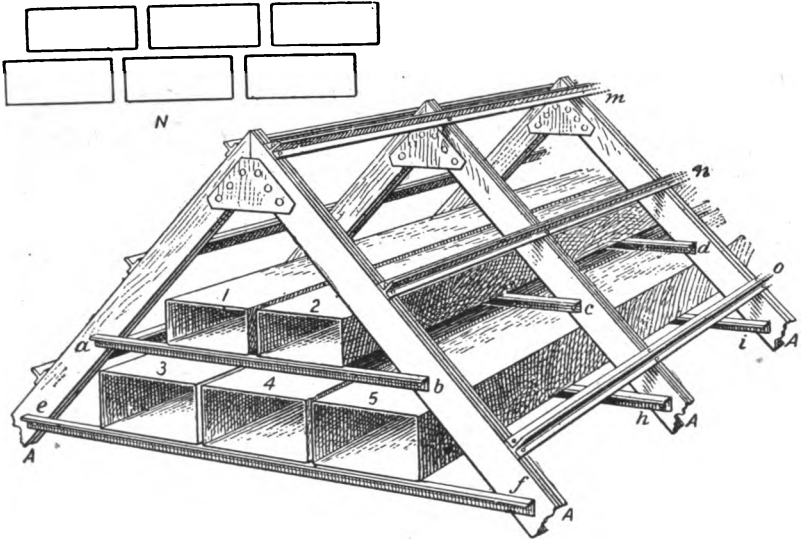

Fig. 86—Supporting Exhaust Ducts in Attic, Before Connecting them to Exhaust Fan Chamber

ing a piece of band iron across the front, as shown by A in Fig. 87, being fastened in the brick joints by small expansion bolts at a and b or by two-inch anchor nails.

When the uptake lies flat against a wall, a simple angle, shown by A in Fig. 88, can be used for a support, it being bolted to the side of the pipe at a and

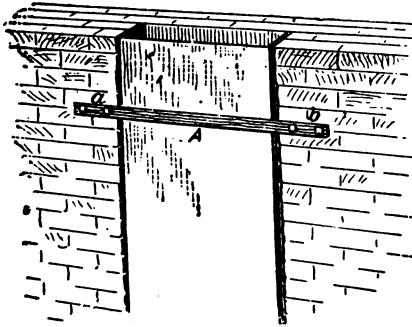

Fig. 87—Fastening the Uptake in a Recessed Wall

to the brick joint at b; or a band passing around the three sides of the pipe as shown at B, bolted or nailed to the brick work at c and d, can be used.

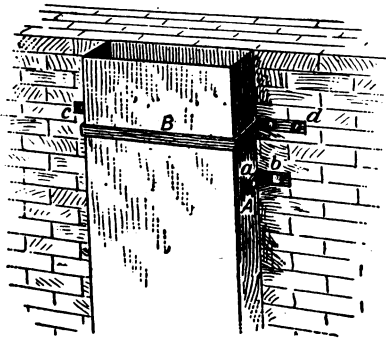

Fig. 88—Two Methods of Fastening the Uptake Against a Flat Wall

Securing Uptakes in Fireproof Construction

The manner of erecting uptakes in fireproof build-

ings is shown in Fig. 89. The uptake F is usually first set, fastening it temporarily against the wall, after which the angle iron framing shown at A, B,

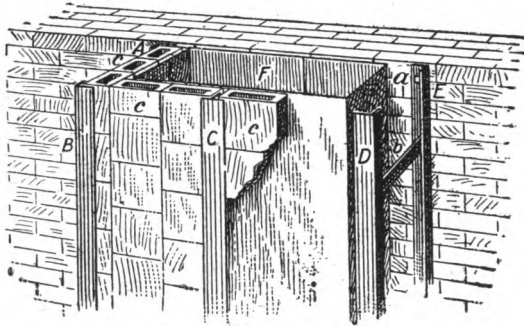

Fig. 89—Setting Heat or Vent Uptake in Fireproof Construction

C, D, E is erected around it, and stiffened with cross braces *b*. The angle iron is allowed to remain a distance away from the uptake on three sides, so as to admit the fireproof blocks, *c, c, c*, etc.

Securing Exposed Uptake

When a heating or ventilating uptake is to be placed in an old building, and will remain exposed, the outer face of the uptake is paneled as shown in Fig. 90, so as to make an attractive appearance, and a panel head is soldered in at the floor and ceiling lines, as shown at B. When setting the uptake together the slip joints are made to occur between the ceiling and floor above, where the uptake is fastened by riveting the angle A to its face and nailing it to the beam as shown. All other exposed joints between the floor and ceiling are soldered complete and scraped smooth and clean, making the uptake in one length from beam to beam, the head B being soldered at

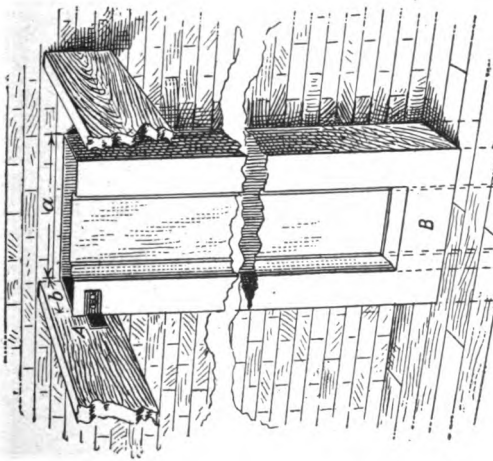

Fig. 90—Method of Constructing and Fastening Exposed Uptake

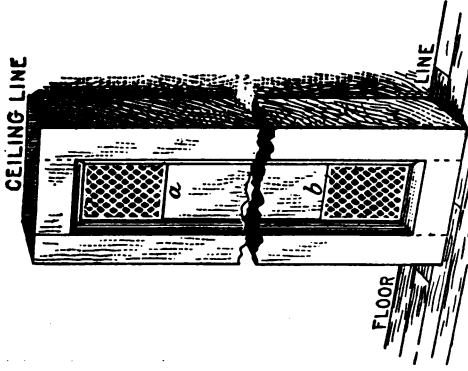

Fig. 91—Method of Placing Registers in Ventilating Uptake

76 *Hanging and Supporting Ducts*

top and bottom in their proper position before erecting. This requires accurate measurements and makes a neat job, as no fastenings are exposed to view. The uptakes are usually bronzed or painted the same color as the wall. Care must be taken to see that the size of the uptake is measured between the points indicated by **a** and **b**, so that the formation of the sunken panel will not reduce its heating or ventilating capacity.

If the uptake just described is to be used for ventilating purposes, registers will have to be placed at the top and bottom, as at **a** and **b** of Fig. 91, riveting the registers to the panel face before erection.

CHAPTER VI.

METHODS OF LAYING OUT AND CONSTRUCTING THE ELBOWS

Elbows

The heel and throat of an elbow are shown in Fig. 92, the heel being the outer and the throat the inner curve. If possible, the radius for describing

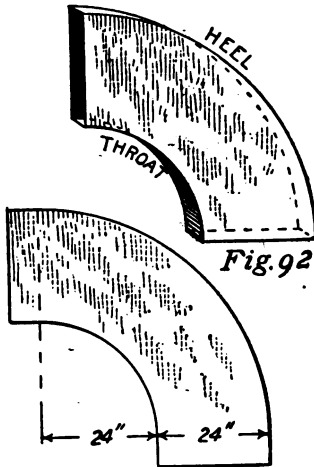

Figs. 92 and 93—Laying Out the Inner
Curve of Elbows

the throat of the elbow, used for heating and ventilating should be equal to the width of the duct, as is shown in Fig. 93.

Adjoining Elbows

When a number of ducts adjoin one another the elbows are laid out as shown in Fig. 94, in which a' is the radius of the throat of elbow 1, being equal to the width of the duct a ; the various elbows, 1, 2 and 3 are then struck from the common center, the

heel of the first thus becoming the throat of the second, and the radius for the heel of the second

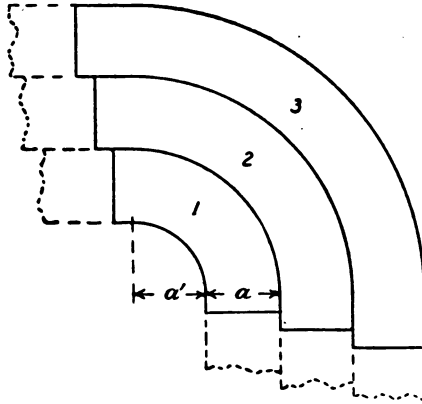

Fig. 94—Method of Laying Out Elbows
When a Number of Ducts Adjoin

elbow becoming the radius for the throat of the third elbow, etc.

Finding Unknown Size in Double Elbow

Supposing that two ducts each 12 in. deep by 24 in. wide are to be connected by means of a double elbow to a single duct having a depth of but 8 in., the unknown width of the duct is found by making the following calculation: Assuming that the two ducts A and B in Fig. 95 are each 12×24 in. in size, then $12 \times 24 = 288$ sq. in. and $288 \times 2 = 576$ sq. in., the combined area in both ducts. As the given depth of the third duct is 8 in., then $576 \div 8 = 72$ in., or the width of the third duct. Thus the area of the third duct is made equal to the combined areas of the other two. This rule is applicable, no matter

whether the first two ducts are the same size or not. Having found the width to be 72 in., the double elbow is laid out as shown in the diagram. With C as center and a radius equal to 24 in. or the width of the duct, draw the quadrant a b. Extend C a and C b indefinitely and make a e equal to 24 in. and set off on C b extended the 72 in. width just found, as shown from b to c, which bisect, obtaining the point d, and through d draw the vertical line shown. Now with radius equal to b c, or 72 in., set off this distance on e C extended, obtaining the point f, and using f as center and f e as radius describe an arc, e, h, cutting the center line at h. Then a, b, d, h, e is one-half the elbow, which is duplicated on the opposite side in the same manner.

Laying Out Large Elbows

When the elbows are of such size that they cannot be laid off on a single sheet of iron, a diagram of the elbow may first be laid out on the floor by means of a trammel and crayon as shown. Assuming that the radius of the throat is to be 36 in. and the radius of the heel 72 in., making the width of the elbow 36 in., then, in case a steel trammel is not at hand, an emergency trammel can be made as shown by A B in Fig. 96. This is bent up from sheet metal to a right angle, each side being about $1\frac{1}{2}$ in. wide, with a hem edge as shown in the profile at Y. A nail can be driven through the corner of the trammel at a into the floor, and from a are measured off on the radius rod, or trammel, the two distances of 36 in. each as shown at b and c. By using the scribe awls as shown, quadrants are drawn upon the floor, and over these marks white crayon

lines are drawn, using a sharpened crayon indicated at X. The trammel can now be removed, and using the steel square, with the corner placed on the center **a**, a right angle is drawn in crayon as shown by **e**, **i**, **a**, **h**, **f**. A straight part to the left of **e**, **i** and below **h**, **f** is always added to the quadrant, to make

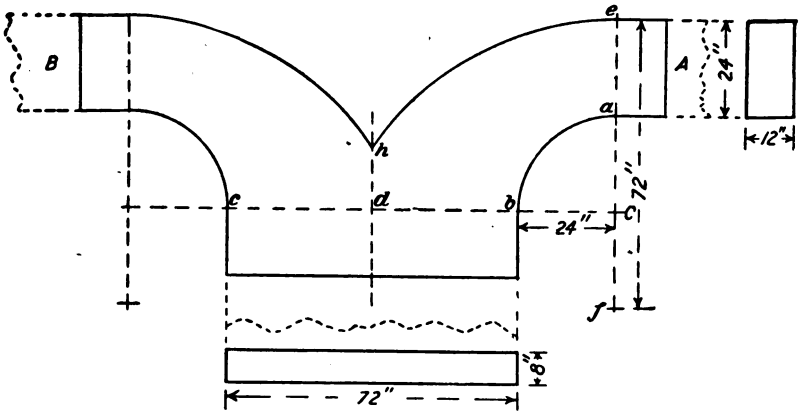

Fig. 95—Laying Out a Double Elbow and Finding the Unknown Size of Third Opening

easy joining to the straight duct. The quadrant is divided into as many sections as will cut to advantage from the sheet of metal, in this case 4, as shown by **l**, **m** and **n**, and from these points radial lines are drawn to **a**. After this view of the elbow has been laid out in chalk on the floor boards a sheet of iron, shown by **T**, is laid over one of these sections (as **3**) and again using the trammel and straight edge, the section **3**, as shown by **m**, **n**, **p**, **o** is reproduced on the sheet metal.

Joining the Segments of the Elbows

The method of allowing edges to these various sections of the elbow for seaming purpose is shown in Fig. 97, where the patterns for 1, 2 and 3 and for 4 are shown, the edges for seaming being indicated by the dotted lines.

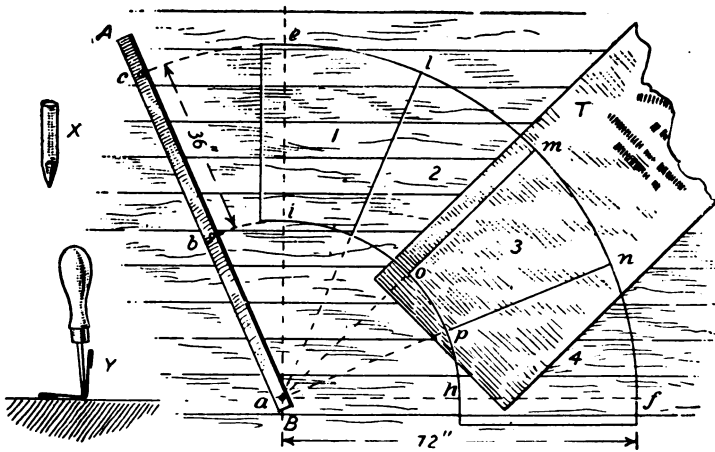

Fig. 96—Laying Out Large Elbows on the Floor and Transferring to the Sheet Metal

The sections of the elbow are joined together in practical work, as shown in Fig. 98, the various sections being joined with a standing locked seam, shown in detail at Z, which gives great rigidity. The edges along the curves at a and a are turned downward in large elbows, to meet an advanced method of seaming, which will be described.

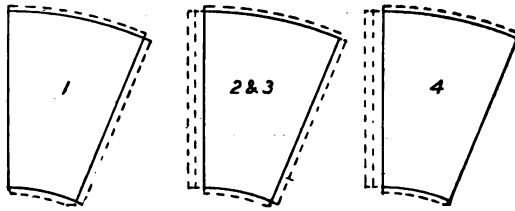

Fig. 97—Patterns for the Segments

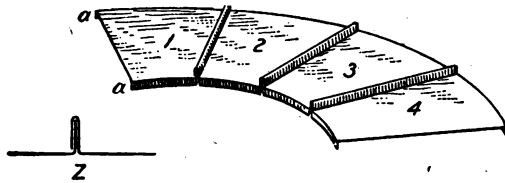

Fig. 98—Showing Sections Locked Together and Forming One Side of the Elbow

Double Seaming the Large Elbows

Fig. 99—General Method Employed in Seaming Elbows

The usual method of double seaming the corners of curved elbows is shown in Fig. 99. The curved sides A and A have single edges turned at right angles, as shown by *a a*, and the straight sides B and B have edges which were previously bent in the brake and which are double seamed as at *b b*, by using

double seaming stakes or hand dollys, which have been already illustrated. An enlarged section of the finished seam is shown at C.

Constructing Large Elbows from Sections

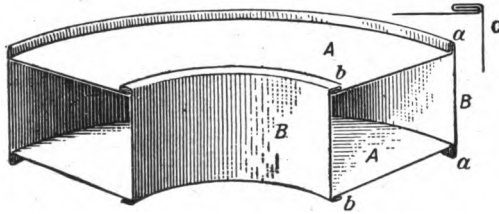
The construction of large elbows to be made in more than one section is illustrated in Fig. 100, in which A and A are the curved sides, with a single edge turned inward as shown. The straight sides

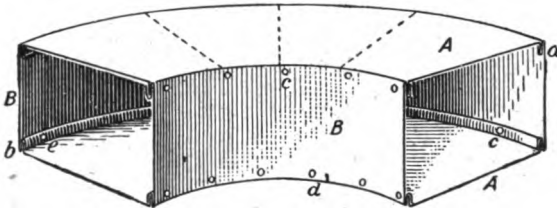

Fig. 100—Seaming and Riveting Large Elbows

B and B are folded as shown at a and b, so as to receive the single edge of the curved sides, after which a few rivets are placed through the seamed joint, as shown at c, d and e. Care must be taken in bending the straight sides B and B so as not to close the receiving lock. This can be avoided by bending the straight sides as shown in Fig. 101, in which A represents a portion of the straight side on which the double lock a has been tightly pressed together. Before turning over the edge b, a strip of metal, slightly heavier than the metal from which the elbow is constructed, is placed in position as shown at c, when the flange b can be clamped down in the brake as shown at d. Still leaving these strips c in the sides, they are passed through the pipe formers until the desired curve is obtained.

Making the Elbows

A quick method of seaming the corners of large elbows without riveting is shown in Fig. 102, in



Fig. 101—Bending the Straight Sides of the Elbow

which the curved sides A and A have the single edges and the straight sides B and B the compound

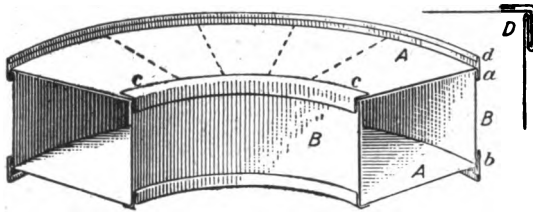

Fig. 102—Quick Method of Seaming Large Elbows, Without Riveting

edges, which are bent as shown from *a* to *b*. The projecting edge at *d* is reinforced with a hem edge as shown, which is turned over the curved face as indicated by *c c*, and shown in detail in the enlarged section at *D*. This is a simple method of easy construction and makes a tight rigid corner.

CHAPTER VII.

CONSTRUCTING REGISTER BOXES, CLEANOUTS AND CEILING VENTILATORS

Constructing Headers

When one dimension of the uptake, as *f, i* in Fig. 103, is similar to one dimension of the box size of the register, as *d, n*, the header and register box can be made as shown, making the header circular as indicated by the arrows *a* and *b*. This allows an easy circulation of air, the corners being double seamed from *c* to *d* and *e* to *f*. Under these conditions it can also be made square, as shown in Fig. 104, the corners being double seamed along *a, b, c* and *d, e, f*.

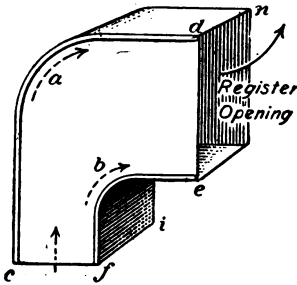

Fig. 103—Galvanized Iron
Circular Header and
Register Box in Heat
Uptake

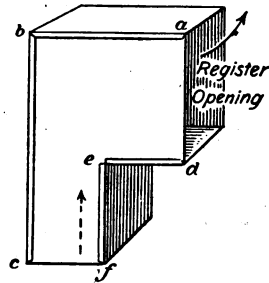

Fig. 104—Galvanized Iron
Square Header and
Register Box in Heat
Uptake

When, however, the width of the uptake is not similar to one dimension of the register, the style of header and register box to be used is shown in Fig.

105. In this form a head A is seamed to the top of the uptake, and a register box of the proper size, as B, is clinched to the uptake as shown.

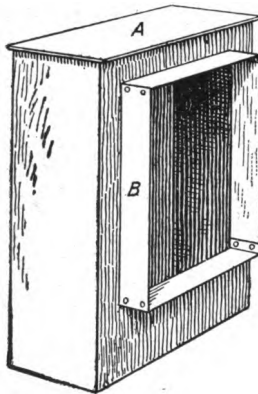

Fig. 105—Another Style of Register Box in Heat Uptake

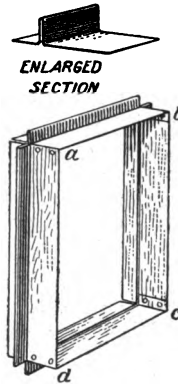

Fig. 106 — Forming Register Collar

Preparing the Collar

This register collar, or box, previous to being clinched to the uptake, is formed as shown in Fig. 106, each side piece being bent separately and all are riveted together at the corners, a, b, c and d. An enlarged section detail, through one side, is shown above.

Clinching the Collar

This header is constructed as shown in Fig. 107, in which A shows the upper part of the uptake, with flanges turned out at the top on the four sides as at a, over which the head B is seamed. The size of the register box being known, an opening is cut in the side of the uptake as shown by b, c, d, e. The register collar, or box, is then clinched to the up-

take, as shown in Fig. 108, in which the box is but partly shown. After the collar A has been riveted or seamed together on the four corners it is set into the opening in the uptake, as shown at a, and the flange a then turned around on the inside of the uptake as shown at b. This holds the register box in

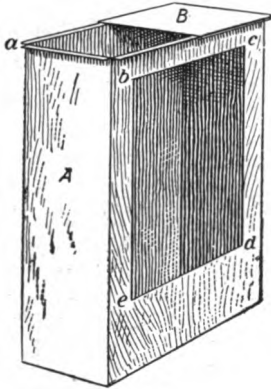

Fig. 107—Seaming Top and Cutting Opening in Uptake to Receive Register Collar

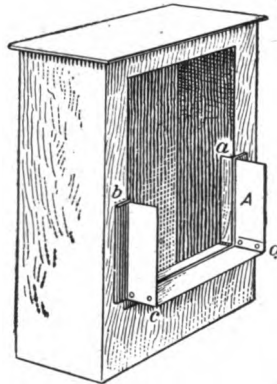

Fig. 108—Method of Clinching the Collar to the Uptake

position. If the corners of the box c and d are riveted, the flat head of the rivet should always be placed on the inside, so as to form no obstruction when placing the register in position.

Finding the Effective Area of a Register

The effective area of any register is found by multiplying the length of the register opening A by the width B of Fig. 109, when the area thus obtained will be the nominal area of the opening; but as the lattice work takes away a certain amount of space, the allowance for this loss is estimated at one-third

of the nominal area, which must be deducted therefrom to obtain the effective area. Thus if A were 20 in. and B 15 in., the nominal area of the opening would be 300 sq. in. If from this amount one-third be deducted the effective area of the opening becomes

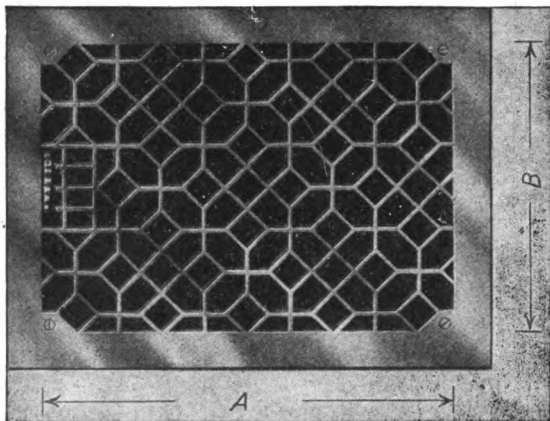

Fig. 109—Finding the Effective Area of Any Register

200 sq. in. When the casting of the lattice or fret work in the registers or face plates is very thick, the effective area is reduced to 50 per cent. of the given size. In other words, a register whose nominal area is 300 sq. in. would have an effective area of but 150 sq. in.

The following tables gives some of the sizes of registers, with their nominal areas, their effective areas, and the sizes of the tin or galvanized iron boxes, with the extreme dimensions of the register faces, the effective area being figured at two-thirds of the nominal area:

The size of a register whose effective or free area

DIMENSIONS OF REGISTERS

Size of opening, Inches	Nominal area of opening, Square Inches	Effective area of opening, Square Inches	Galv. Iron or Tin Box Size, Inches	Extreme dimensions of register face, Inches
6 x 10	60	40	6 ³ / ₁₆ x 10 ³ / ₁₆	7 ¹ / ₁₆ x 11 ¹ / ₁₆
8 x 10	80	53	8 ³ / ₁₆ x 10 ³ / ₁₆	9 ³ / ₁₆ x 11 ³ / ₁₆
8 x 12	96	64	8 ³ / ₁₆ x 12 ³ / ₁₆	9 ³ / ₁₆ x 13 ³ / ₁₆
8 x 15	120	80	8 ³ / ₁₆ x 15 ³ / ₁₆	9 ³ / ₁₆ x 16 ¹ / ₁₆
9 x 12	108	72	9 ¹ / ₁₆ x 12 ¹ / ₁₆	10 ³ / ₁₆ x 13 ³ / ₁₆
9 x 14	126	84	9 ¹ / ₁₆ x 14 ¹ / ₁₆	10 ³ / ₁₆ x 15 ³ / ₁₆
10 x 12	120	80	10 ¹ / ₁₆ x 12 ¹ / ₁₆	11 ¹ / ₁₆ x 13 ¹ / ₁₆
10 x 14	140	93	10 ¹ / ₁₆ x 14 ¹ / ₁₆	11 ¹ / ₁₆ x 15 ¹ / ₁₆
10 x 16	160	107	10 ¹ / ₁₆ x 16 ¹ / ₁₆	11 ¹ / ₁₆ x 17 ³ / ₁₆
12 x 15	180	120	12 ³ / ₁₆ x 15 ³ / ₁₆	14 ¹ / ₁₆ x 17
12 x 19	228	152	12 ³ / ₁₆ x 19 ³ / ₁₆	14 ¹ / ₁₆ x 21
14 x 22	308	205	14 ³ / ₁₆ x 22 ³ / ₁₆	16 ³ / ₁₆ x 24 ³ / ₁₆
15 x 25	375	250	15 ³ / ₁₆ x 25 ³ / ₁₆	17 ³ / ₁₆ x 27 ³ / ₁₆
16 x 20	320	213	16 ³ / ₁₆ x 20 ³ / ₁₆	18 ³ / ₁₆ x 22 ³ / ₁₆
16 x 24	384	256	16 ³ / ₁₆ x 24 ³ / ₁₆	18 ³ / ₁₆ x 26 ³ / ₁₆
20 x 20	400	267	20 ¹ / ₁₆ x 20 ¹ / ₁₆	22 ³ / ₁₆ x 22 ³ / ₁₆
20 x 24	480	320	20 ¹ / ₁₆ x 24 ¹ / ₁₆	22 ³ / ₁₆ x 26 ³ / ₁₆
20 x 26	520	347	20 ¹ / ₁₆ x 26 ¹ / ₁₆	22 ³ / ₁₆ x 28 ³ / ₁₆
21 x 29	609	403	21 ¹ / ₁₆ x 29 ¹ / ₁₆	23 ³ / ₁₆ x 31 ³ / ₁₆
27 x 27	729	486	27 ¹ / ₁₆ x 27 ¹ / ₁₆	29 ³ / ₁₆ x 29 ³ / ₁₆
27 x 38	1026	684	27 ¹ / ₁₆ x 38 ¹ / ₁₆	29 ³ / ₁₆ x 40 ³ / ₁₆
30 x 30	900	600	30 ¹ / ₁₆ x 30 ¹ / ₁₆	32 ³ / ₁₆ x 32 ³ / ₁₆

Dimensions of different makes of registers vary slightly. The above are for Tuttle & Bailey Mfg. Co.'s manufacture.

will be equal to the area of the uptake is determined as follows: If the fret or grill work in the register is very delicate, then multiply the area of the uptake by 1.5 and divide the product by the given dimension of one side of the register. This will determine the unknown side. This rule is clearly explained in connection with Fig. 110, in which the size of the uptake is 10 x 30 in. and equals 300 sq. in. 300 x 1.5 = 450. Assuming that a register is desired whose length is 24 in., the unknown width is found by

dividing 450 by 24, which is $18\frac{3}{4}$ in. Thus a register whose dimensions are $18\frac{3}{4} \times 24$ in. will have a nominal area of 450 sq. in. and an effective or free area of 300 sq. in., which is equal to the area of a 10×30 in. uptake. In calculating the sizes of the registers, a trade catalog should be obtained, from which only standard sizes should be selected, as special sizes and patterns are costly. Following the table given herewith of standard sizes of register, the nearest to the size above $18\frac{3}{4} \times 24$ is found to be 20×24 , which is used as shown in the figure. It is always better to use a size slightly larger than one too small.

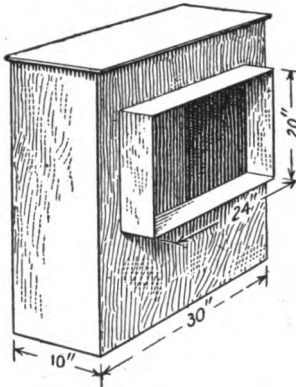

Fig. 110—Determining the Size of the Register from the Size of the Uptake

If the fret or grill work in the register is very coarse and thick, then the area of the uptake should be multiplied by 2, which will make the effective area of the register one-half of the nominal area. Thus in an uptake whose dimensions are 10×30 in., the size of the register whose effective area will be one-half of the nominal area, is obtained as follows:

$10 \times 30 = 300 \times 2 = 600 \div 24 = 25$; making the register 24 in. (the given width) by 25 in. the found length. $25 \times 24 = 600$ sq. in., the nominal area; $600 \div 2 = 300$ sq. in., the effective area, equal to the area of the 10×30 in. uptake. Following the table of standard sizes of registers, the nearest stock size would be 24×27 , which is the one to be used.

STANDARD SIZES OF REGISTERS.

Size of Opening.	Size of Opening.	Size of Opening.	Size of Opening.
4 x 6	6 x 30	12 x 14	18 x 27
4 x 8	6 x 32	12 x 15	18 x 30
4 x 10	7 x 7	12 x 16	18 x 36
4 x 12	7 x 10	12 x 17	20 x 20
4 x 13	7 x 12	12 x 18	20 x 22
4 x 15	7 x 14	12 x 19	20 x 24
4 x 18	8 x 8	12 x 20	20 x 26
4 x 21	8 x 10	12 x 24	20 x 28
4 x 24	8 x 12	12 x 30	20 x 30
5 x 8	8 x 14	12 x 36	20 x 36
5 x 9	8 x 16	14 x 14	21 x 29
5 x 10	8 x 18	14 x 16	22 x 22
5 x 12	8 x 20	14 x 18	22 x 24
5 x 14	8 x 21	14 x 20	22 x 26
5 x 16	8 x 24	14 x 22	22 x 28
5 x 18	8 x 30	14 x 24	22 x 30
6 x 6	9 x 9	16 x 16	24 x 24
6 x 8	9 x 12	16 x 18	24 x 27
6 x 9	9 x 13	16 x 20	24 x 30
6 x 10	9 x 14	16 x 22	24 x 32
6 x 12	9 x 16	16 x 24	24 x 36
6 x 14	9 x 18	16 x 28	27 x 27
6 x 16	10 x 10	16 x 30	27 x 38
6 x 18	10 x 12	16 x 32	30 x 30
6 x 20	10 x 14	16 x 36	30 x 36
6 x 22	10 x 16	18 x 18	30 x 42
6 x 24	10 x 18	18 x 21	30 x 48
6 x 28	10 x 20	18 x 24	*36 x 36
	12 x 12		*38 x 42

*Made to order.

Cleanout and Register Box

The register box and cleanout in a ventilating uptake are constructed as shown in Fig. 111. The bot-

tom surface is made curved from *a* to *b*, with a cleanout opening placed in line with the floor. The size of the register box and its method of fastening is similar to that already explained. The cleanout opening need be no larger than is necessary to easily re-

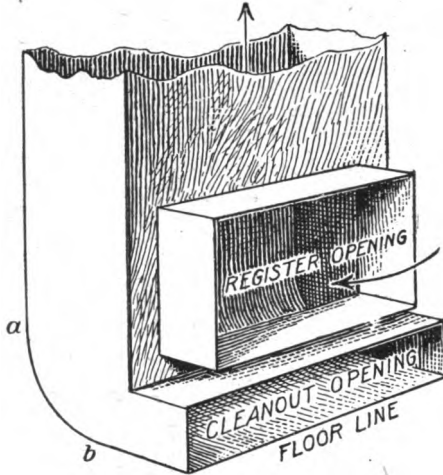

Fig. 111—Cleanout and Register Box in a Vent Uptake

move the dust and dirt which is drawn in. Unless this is frequently removed, it will cause annoyance to occupants of the building. The opening in the cleanout is finished by means of a cleanout door, as shown in Fig. 112. A hinge is placed along *a b*, and two turn buckles are placed at *c* and *d* for use in opening and closing.

This cleanout door is constructed as shown in Fig. 113, which is a vertical section through the door and frame. Attention is called to the formation of the door frame at *A* and *B*, which is similar on all four

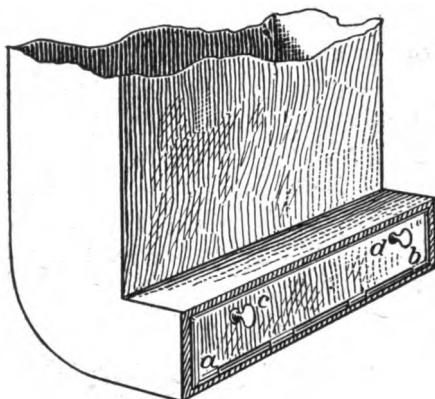

Fig. 112—Cleanout Door in Position

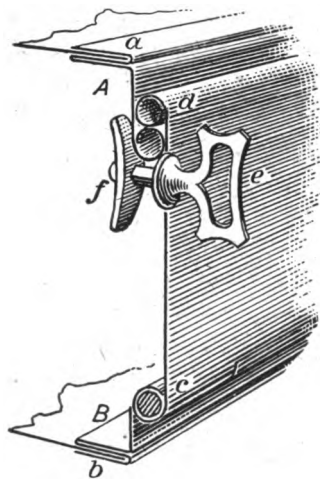

Fig. 113—Vertical Section Through Door and Frame of Cleanout

sides. The frame slips over the cleanout collar at a and b, is hinged along the lower side at c and the

beaded edge at **d**, slips over the beaded edge of the frame on the other three sides. The turn buckle, shown at **e**, is turned to open or close the door, holding it closed by means of the tongue **f**.

The turn buckles generally employed are made of malleable iron and galvanized, and are usually of the shape shown. A hole is punched in the door to admit the shank. The tongue **f** can be obtained either straight or curved.

Vent Outlets

When ventilating large assembly rooms or halls, the vent outlets should, if possible, be placed in an inside wall, so as to prevent the air in the uptake from becoming chilled and causing its flow to become sluggish. The outlets should be placed as shown in Fig. 114, in which **A** is the vent uptake, **B** the outlet near the ceiling for carrying off the animal heat and heat from respiration as fast as it is given off, and **C** the outlet, near the floor, for carrying off the cooler impure air which sinks to the bottom of the room.

B in this figure is a type of what is termed a "through register box," that is, one which has no header at the top, as in a heat uptake, or at the bottom as in a vent uptake. Another style of "through register box" is shown in Fig. 115, which is constructed with curves at **a** and **b**. It is used both in heat and vent uptakes, when the box size of the outlet **c**, **d** is equal to **e**, **f** of the uptake.

Heat Inlets

When heating large assembly or school rooms the heat inlets or register boxes should be placed as

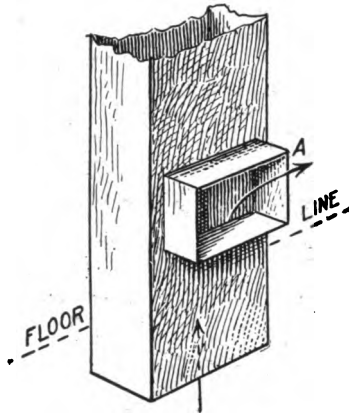
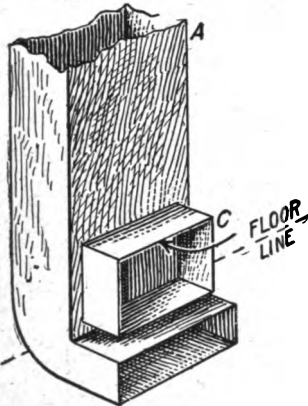
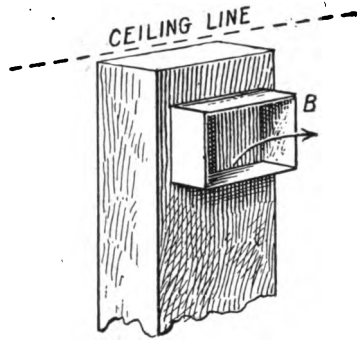
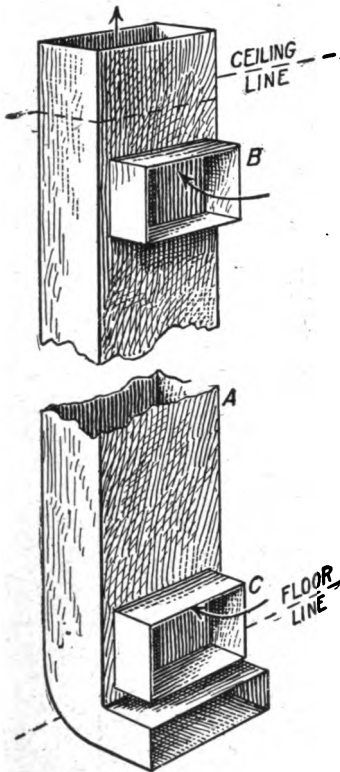

Fig. 114—Vent Uptake with Two Register Boxes and Cleanout

Fig. 116—Heat Uptake with Two Register Boxes

shown in Fig. 116, one near the floor at A, which brings the warm air to the coldest part of the room and another near the ceiling at B. This gives a more even distribution of pure air throughout the room or hall. The cooler air sinks to the bottom of the room because it is heavier and is carried off by the vent registers; while the animal heat given

off from the bodies in the audience rises to the ceiling and is carried off through vent outlets near the top of the room.

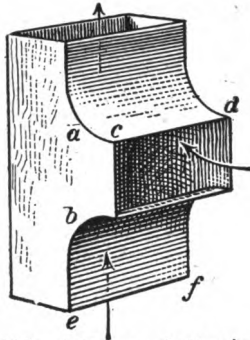

Fig. 115—A Through Register Box in a Heat or Vent Uptake

When a heat or vent duct is placed between the ceiling and floor, the register box or collar, A in

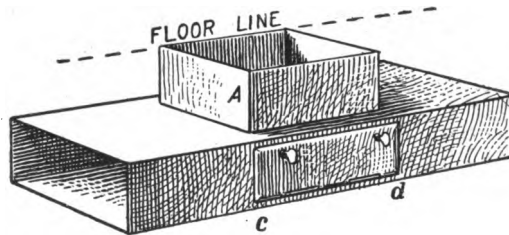

Fig. 117—Register Box and Cleanout in a Heat or Vent Duct Placed Between Floor and Ceiling

Fig. 117, should be so placed that its top edge will be flush with the floor line. The cleanout door is usually placed on the bottom or at one side of the duct, as shown, and hinged at c, d. Turnbuckles,

placed as in Fig. 112, allow it to be opened for the cleaning out of dirt and dust falling through the register face.

The duct is prepared for receiving the register box and cleanout frame as shown in Fig. 118.

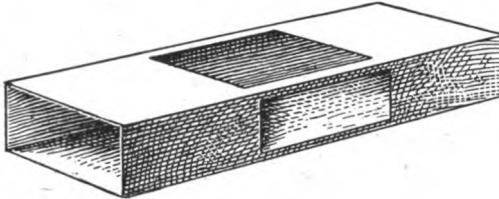

Fig. 118—Opening Cut in Duct to Receive the Register Box and Cleanout Door and Frame

When the cleanout frame joins the duct at the side it is constructed as shown in Fig. 119. The frame is formed as indicated by A, A, with a standing edge shown by a, a. This edge is inserted into the opening in the duct b, b and the edges a turned down tight as at c, c; the door is shown by B.

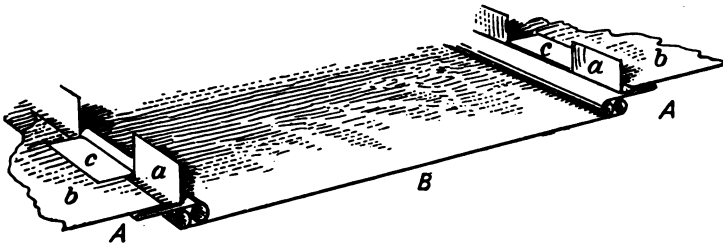

Fig. 119—Construction of Cleanout Door and Frame

The collar of the register box should have sufficient length so that its outer edge will be flush with the wooden border or iron frame, as shown in Fig. 120, which in turn is flush with the plaster line.

As registers are only placed in position after the completion of the building, provisions are made to keep the register boxes true and square and prevent the dirt and building material from getting inside the ducts by means of temporary galvanized iron

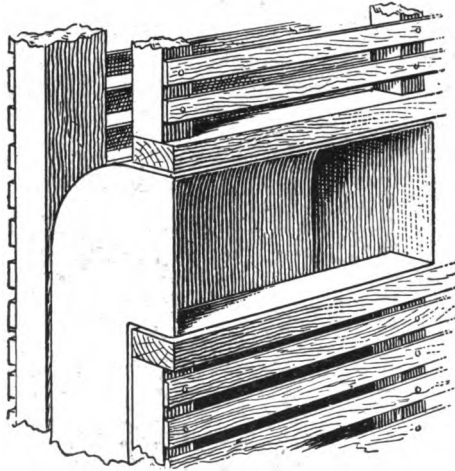

Fig. 120—How Register Boxes Should Be Carried Flush with the Plaster Line

heads, placed in the register boxes as shown by A in Fig. 121. In this view the head is made sectional so as to show the formation of the locks *a* and *b*, which are clinched at intervals to hold the cover in position. When the registers are put in place these heads are removed and should be saved for use again on future jobs having the same size boxes.

Ceiling Ventilators

In theaters or large halls where the heat from gas lights must be carried off, provisions are made by

placing round registers in the ceiling similar to those shown in Figs. 122 and 123, which are screwed to a framing provided for same. When these registers are large and very heavy, as that shown in Fig. 123, ceiling ventilators made of stamped metal, as shown in Fig. 122, may be substituted. These can be obtained in any size, stamped from zinc or copper. They are light in weight and can be easily fastened.

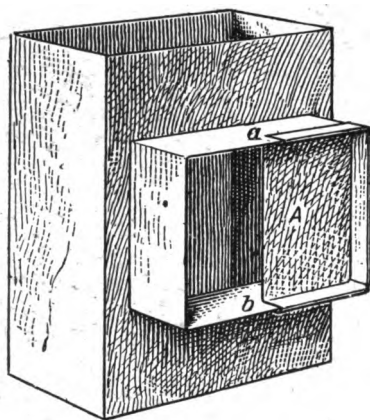

Fig. 121—Method of Putting in Register Head

- When the ventilation of any large hall, theater or church is carried to the attic through the ceiling vents, this impure air is sometimes carried to the outside from the attic by means of louvre ventilators, placed over the ridge of the roof and an operating damper, as shown in detail in Fig. 124, is placed below. In this figure the ceiling ventilator is shown fastened at A and B with the gas pipe or electric insulation passing through it. A skylight, which allows the sunlight to come into the attic, is placed over the damper,

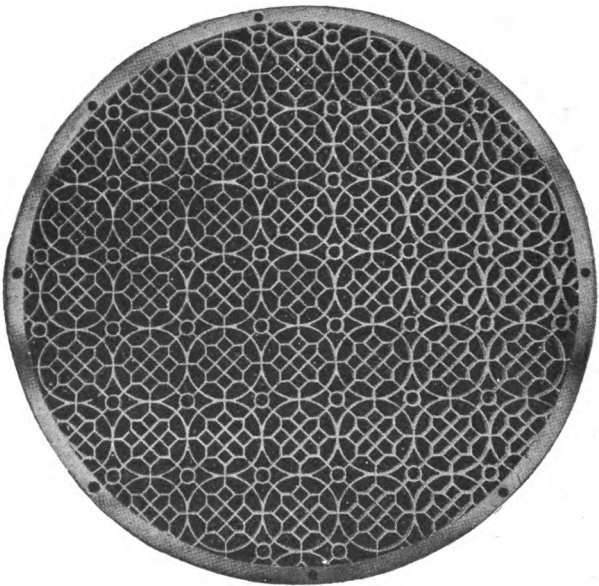

Fig. 122—Stamped Zinc or Copper Ceiling Register Fig. 123—Cast Iron Ceiling Register for Ventilating

with stationary louvres, as indicated by C. On the curb, below the louvres, a single damper is placed,

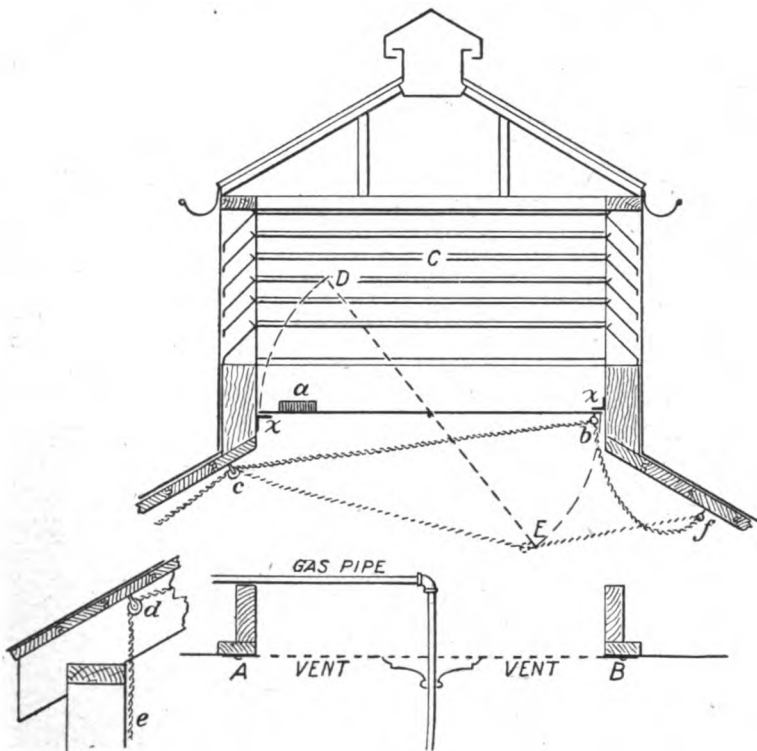

Fig. 124—Method of Placing Louvres on Roof Over Ceiling Register and Operating Damper

as shown by D, E, which closes automatically by means of a weight attached at a and falls against the angles at x and x.

To open the damper from the inside, a brass safety chain is attached to the damper at b, which runs over brass pulleys at c and d and through the ceiling as

shown. When the chain is drawn down at *e*, the damper will, if not prevented, have a tendency to turn around too far and reclose. To avoid this a piece of chain of the proper length is fastened to the ring of the damper at *b*, the other end being fastened to a staple at *f*. This prevents the damper from being opened too far when the chain is drawn down, as indicated by *f*. When the chain *e* is unfastened, the damper will close of itself, by means of the weight *a*. A damper of this kind should only be used when the louvre ventilator is of small size. When it is of large size, operating louvres should be employed, which are worked by means of gearings from the inside.

Construction of Damper

A damper, to be used as shown in the preceding pages, should be constructed with a riveted band iron frame covered with corrugated or crimped sheet

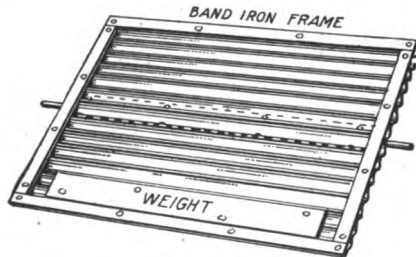

Fig. 125—Damper Construction

metal, as shown in Fig. 125. The galvanized sheet metal used should not be lighter than number 22 gauge, depending upon the size of the damper, the smaller sizes being made of a lighter gauge

When limited ventilation is required and a louvre ventilator is not used, a round or square ventilator

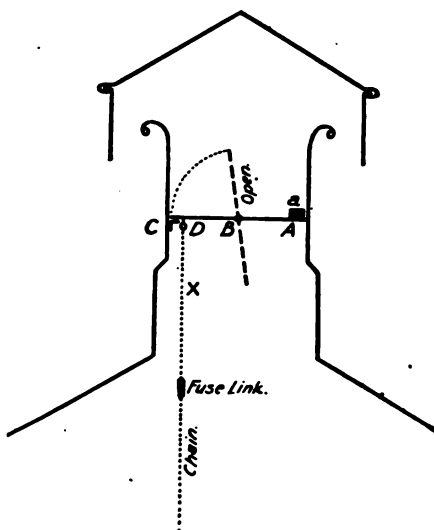

Fig. 126—Providing for Limited Ventilation

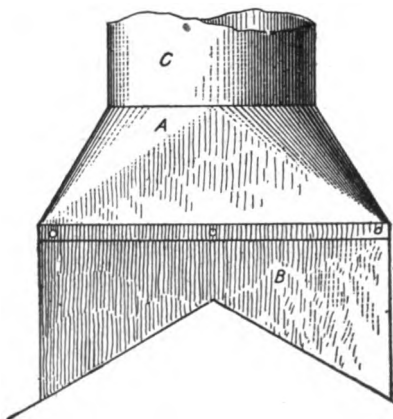

Fig. 127—The Base for a Round Ventilator

similar in section to that shown in Fig. 126 may be employed. In this case a damper is placed on the inside at A, pivoted at B. An angle is secured to the ventilator body at C, on which the damper rests, when closed. A ring is attached to the damper at D and to this ring is attached a chain with a fusible link as shown. The damper may be closed by fastening the chain X. A weight is attached to the damper at a so that it will open when the chain is loosened or in case of fire, when the fusible link will melt and the damper will open to permit the escape of smoke.

A square curb is placed in the roof as shown by B in Fig. 127, and the round ventilator C is joined to the curb by means of a square to round transition piece shown at A.

Non-Conducting Covering

The clean-out doors on the main heat supply ducts in the basement or cellar are usually placed at intervals along the under side of the duct as previously

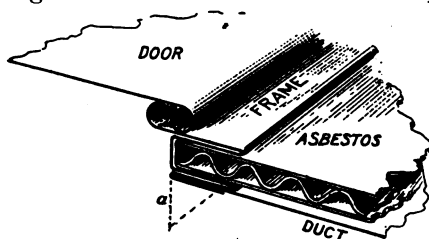

Fig. 128—Asbestos or Other Non-Conducting Covering Over Heat Duct

explained and shown in Fig. 119, being hinged on one side and fastened with a number of turn buckles as required.

As these ducts are usually covered with non-conductive material to avoid loss of heat, the clean-out

frame is constructed so that a finish can be made around the frame with the non-conductive material.

A detail of this construction is shown in Fig. 128, in which the formation of the clean-out frame is clearly shown. Note that the lower flange clinches around the opening in the metal duct, which holds it firm, and that an allowance is made for the insertion of the asbestos or other covering according to the thickness required.

The heat ducts forming the main supply to the uptakes are usually covered with asbestos one inch in thickness, then this is covered with 10 oz. canvas, which is painted with two coats of white cold water paint. The asbestos covering used is corrugated similar to that shown in Fig. 129.

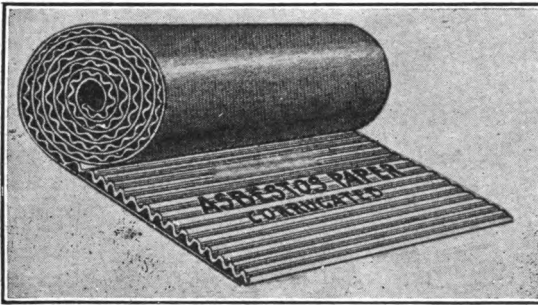

Fig. 129—Asbestos Air Cell Covering

The relative value of the non-conductive material is given in the following table:

Non-Conductors.	Value.	Non-Conductors.	Value.
Wool felts	1.000	Loam, dry and open...	.550
Mineral wool, No. 2...	.832	Slaked lime480
Mineral wool, with tar.	.715	Gas house carbon.....	.470
Sawdust680	Asbestos363
Mineral wool, No. 1....	.676	Coal ashes345
Charcoal632	Coke, in lumps277
Pine wood, across fibre	.553	Air space, undivided....	.186

CHAPTER VIII.

REGISTERS FOR HEATING AND VENTILATING DUCTS

Styles of Registers

Registers can be obtained, finished in black japan, white japan, porcelain enamel, or bronzed in gold, silver, copper or bronze. They can also be obtained in solid brass or bronze metal highly polished, or nickel, oxidized copper and brass, antique copper and brass, gun metal, etc., and also in metal which has been electroplated with copper, brass, bronze or nickel.

When registers are to be connected direct to the brick flues, they are fastened by means of reverse beveled cast iron wall frames, shown in Fig. 130,

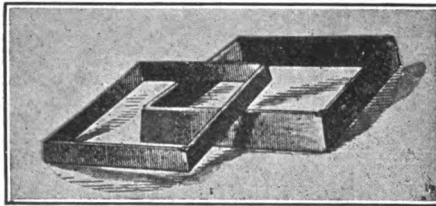

Fig. 130—Beveled Wall Frames

which furnish the best means for securely holding the register in place. They are built in the wall as shown in Fig. 131, the widest side of the frame, *a*, facing the inside of the flue. The register is attached to the frame by means of screws, which can be removed or

replaced without any damage to the wall. The frames can be obtained to suit any size register.

Fig. 132 shows a register having a plain lattice ventilating face, without any shut-off valves or louvres

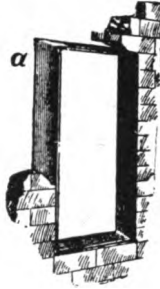

Fig. 131—The Wall
Frame in Position

in the back of same. It is usually placed in the ventilator openings.

Wire grilles or register faces, two styles of which are shown in Fig. 133, are sometimes used.

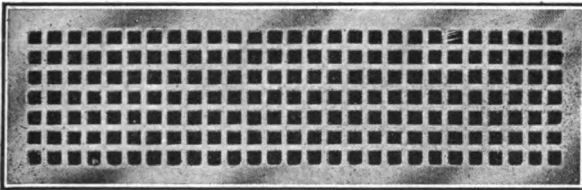

Fig. 132—Plain Lattice Ventilating Face

When a register face is required in a room whose wall is curved as in a bay window, registers having concave faces are used.

Knowing the radius of the curve of the wall, this dimension is sent to the factory and the faces are then

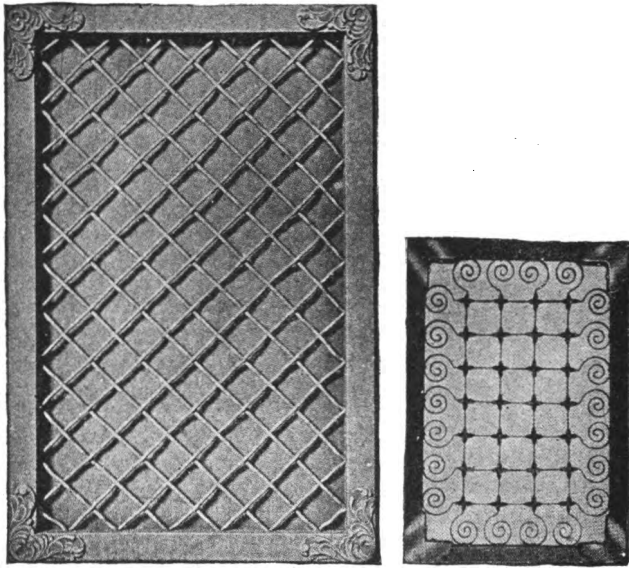

Fig. 133—Two Styles of Register

made to the required curve, similar to that shown in Fig. 134, which is called a concave register face.

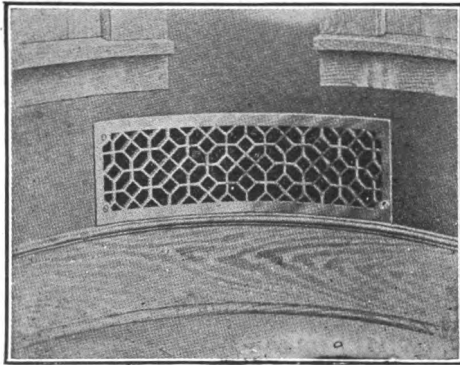

Fig. 134—Concave Register Face

Round ventilating plates similar to that in Fig. 135 can be obtained in any diameter.



Fig. 135—Round Ventilating Plate

A convex baseboard ventilating plate or register is shown in Fig. 136. It is a plate that projects outward from the face of the wall, as shown in the illustration.

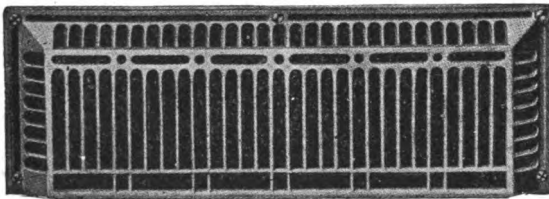

Fig. 136—Convex Baseboard Ventilating Plate

The style of registers placed in the warm air inlets is that having shut-off valves or louvres in the back, for opening or closing. They are operated by means of the quadrant X, Fig. 137, more fully illustrated in Fig. 138, which shows one end of the inside of the register and the operating mechanism A indicating the quadrant.

Floor registers are usually set in a cast iron floor border, as shown in Fig. 139.

When a round register is to be set in a floor, the

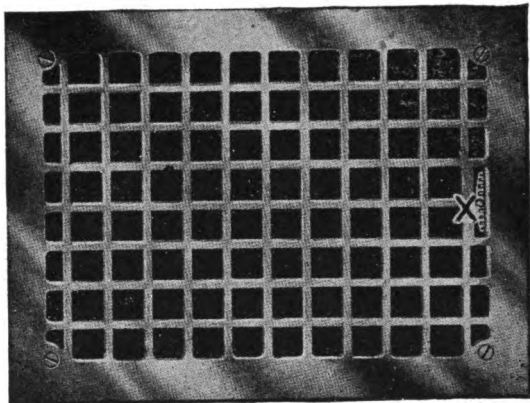

Fig. 137—A Heat Register

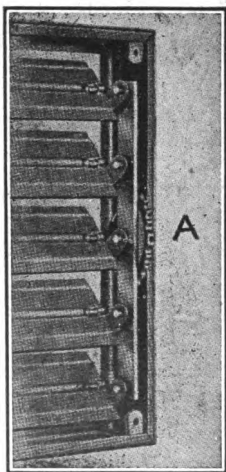

Fig. 138—Showing Operation of Shut-Off Valves

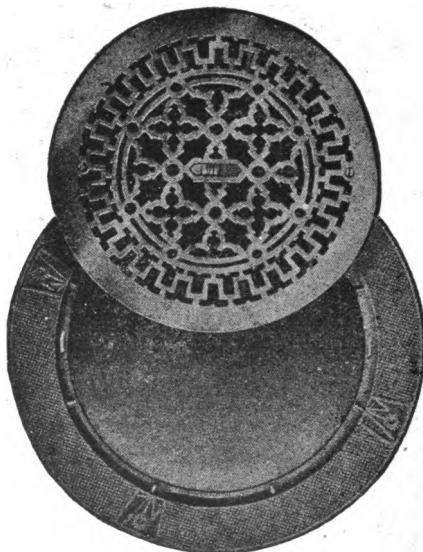

Fig. 140—Round Register with Cast Iron Floor Border

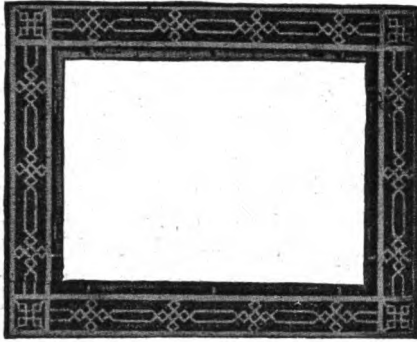

Fig. 139—Cast Iron Floor Border

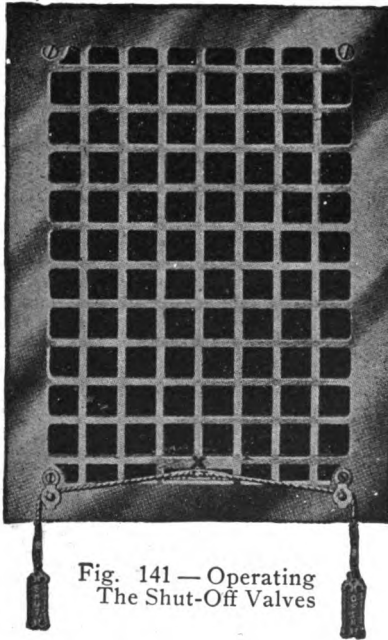

Fig. 141 — Operating
The Shut-Off Valves

wood work must be prepared by the framer to receive the circular floor border shown in Fig. 140, into which the register is placed.

When heat registers are placed near the ceiling, two cords or chains of the required length are fastened to the quadrant X, in Fig. 141, having indicator handles marked "Open" and "Shut," by which the register can be opened or closed from the floor. These cords or chains pass over small brass pulleys as shown.

CHAPTER IX.

FASTENING AND ADJUSTING REGISTERS

Register faces are fastened to the wall as shown in Fig. 142, in which a and a show the wooden frame around the duct outlet, to which, after the plastering is completely completed, the register is screwed as indicated by using brass or enamel headed screws to match the face of the register.

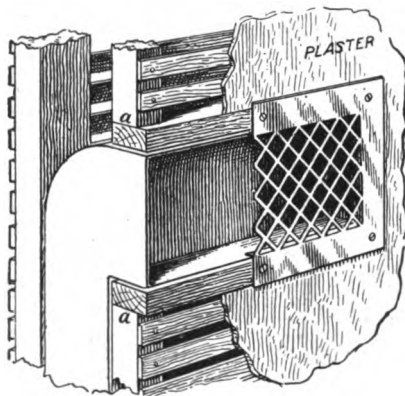

Fig. 142—Fastening the Register Face to Wall Joist

When the wall construction is of angle iron or brick, and no wood work is allowed, the side wall registers are secured, as shown in Fig. 143. An angle iron frame is placed around the duct opening and secured to the upright tees, allowing sufficient space between the T's and angle for the thickness of the plaster, the plaster being held in place by the wire mesh, which

is secured to the upright tees. Holes are drilled and tapped in the angle iron frame at **a a**, etc., to correspond to the holes in the register face **b b**, which can then be screwed in place or removed without injuring the plaster.

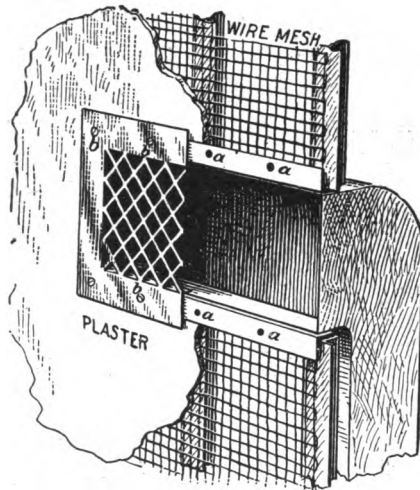

Fig. 143—Fastening the Register Face to Angle Iron

Fastening Register to Metal Duct

When the metal duct is exposed and the register must be fastened direct to the sheet metal, as shown at the left in Fig. 144, an opening is cut in the face of the sheet metal duct of the required size, as shown by **a b**, and the register **B** bolted to the sheet metal as shown.

Fastening Floor Register

Floor registers are fastened as shown in Fig. 145. After the register box **C** has been seamed to the duct **D** at **a a** and set in its proper position, the cast iron floor border **A** is set, over which the register is placed,

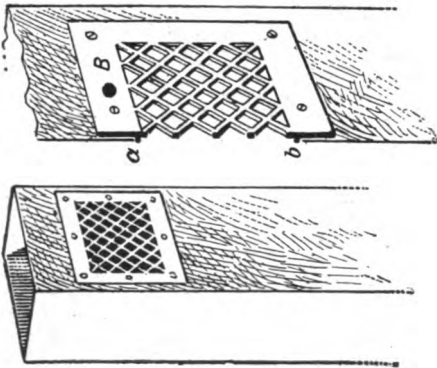

Fig. 144—Fastening Register Face to Sheet Metal Duct

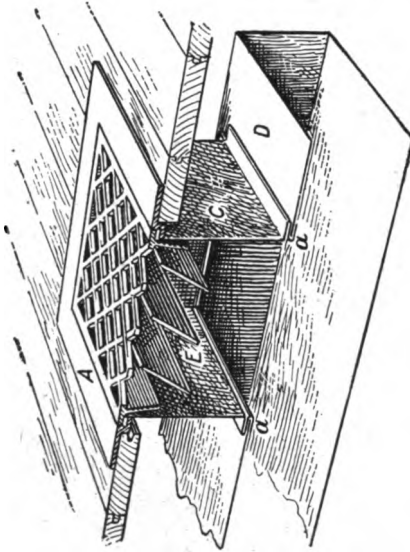

Fig. 145—Attaching Floor Register to Register Box

fitting into the register box or collar as shown. E represents the valves, which can be turned in a vertical or a horizontal position, thus opening or closing the register.

The Use of the Heat Deflectors

When the heat registers are placed near the floor, a heat deflector made from galvanized iron or brass, as shown by A in Fig. 146, can be used for deflecting the heat towards the floor. The hot air striking the upper shield A is deflected in the direction of the

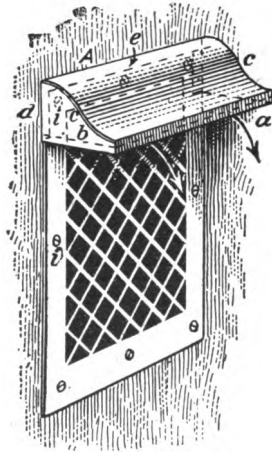

Fig. 146—Heat Deflector
on a Register

arrows. A hem edge is placed along the bottom of the deflector at the sides and front as shown by a and b, and it is double seamed along the curved part at c and c. At the back of the sides and top a $\frac{3}{4}$ -inch flange is bent as indicated by d and e, which is slipped behind the register face, so that when the screws i i

are securely fastened, the deflector will be held firmly in place.

Fastening Registers to Marble or Slate Side Walls

When the heat inlets or vent outlets connect to marble or slate side walls, great care must be taken to have the duct properly and accurately located, so

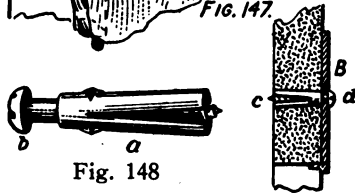
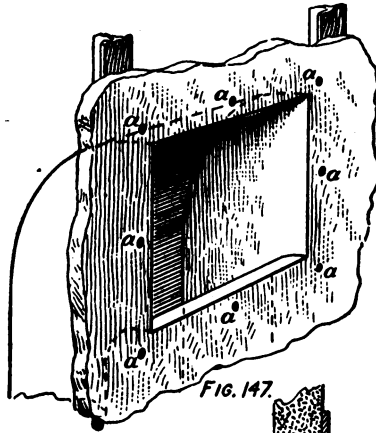

Fig. 148

Fig. 147—Drilling the Marble or Slate for the Register
Fig. 148—Screw Anchor for Fastening the Register to Slab

that the marble or slate work will fit accurately, as shown in Fig. 147, when the registers are sometimes fastened by means of plaster of paris, which, however, makes their removal difficult. A better plan which allows for their easy removal, is obtained by holding the register in position, marking the holes and drilling the

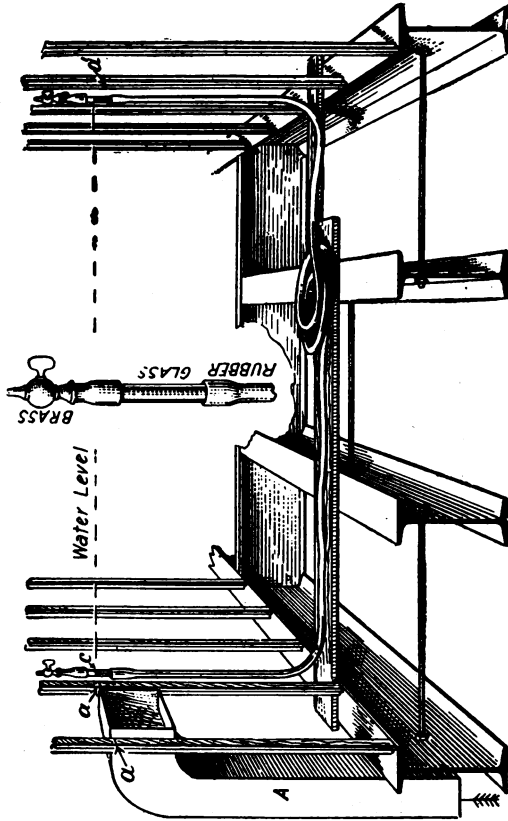

Fig. 149—Apparatus for Obtaining Location of Register with Water Level

marble as shown at **a**, etc. The holes having been drilled in the marble or slate, the register faces are secured by means of a screw anchor and ordinary wood screws, as shown respectively by **a** and **b** in Fig. 148. The screw anchor is made of a lead composition metal in one piece, and is so constructed that the screw cuts its own thread. This enables it to be used with any wood, machine or other screw. As the lead anchor requires a small hole for its insertion, there is no tendency to break, chip or deface the finest marble. The lead composition being non-rusting, no streaks will show on the marble face. The screw can be of brass or nickel plated to suit the register face. The holes being drilled, the lead anchor is inserted flush with the surface of the marble, as shown in the sectional view at the right, after which the register is held in place and the screws passed through holes in same, into the lead anchor, and fastened tightly.

Locating Register Openings by Means of the Water Level

The location of the vent or heat openings being given, or the location being given on one side of the room, it often becomes a question how these openings can be located on a large job, where a great number are required, or how a similar location be found in other parts of the room, when the floors are not laid or the room is filled with various building materials and no measurements can conveniently be made. This can be accomplished by means of a simple contrivance shown in Fig. 149 known as the water level, which consists of a half-inch inside diameter rubber tubing, having a glass tube and a brass cock, on either end as shown in the enlarged detail. The operation

of the water level is as follows: Assuming that the marks at *a* and *a* on the angle irons indicate the given location of the top of the register head of the duct *A*, similar locations in various parts of the room can be found by first filling the entire hose with water to the top of the brass cocks; this drives out all the air. Sufficient water is now run off, so that the water will show to the middle of the glass tubes on each end. The pet cocks are now closed and the water level is ready for use. To find a location at the same height as *a a* in any part of the room, open the pet cocks to allow the water to circulate by driving out or drawing in the air through the openings in same. Now hold the middle of the glass tube to the mark at *a* and raise or lower the opposite glass tube *a'* until the water will come to a level with *a* as indicated at *c*. As water rises to its own level, the water mark on the opposite side will show at *a'* and will indicate the desired location. The pet cocks can now be closed, thus keeping the water in the tube for the next operation. This is a simple contrivance which saves considerable time when a large number of register openings are to be located. Even though the beams are laid and the floor is clear, sometimes the openings could not be accurately measured from the beam, because in most cases the level of the beams cannot be depended upon.

CHAPTER X.

CONNECTING HEATING AND VENTILATING DUCTS

Connections with Brick Flues

A mistake is often made in finishing the brick ventilating flues at the attic floor line, previous to connecting same to sheet metal ducts. The brick flue is usually built up flush with the floor line, as shown in Fig. 150, which is incorrect; because the metal duct must then be connected by means of flanging inside of the brick flue, also flanging on the outside and nailing to the floor, which does not make an airtight connection.

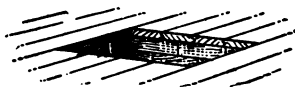

Fig. 150—Incorrect Way of Finishing Brick Shaft to Receive Sheet Metal Connection

The connection should be made between the brick flue and metal duct, so as to insure an airtight joint, as shown in Fig. 151. The brick flue should be stopped at B, or about three courses below the floor level, after which the metal connection shown by A, with 3-inch flanges around its base, as a a, is set on the brick level at B, being careful to have the metal bases painted with metallic paint and dried before setting. The three courses are now built up to b b, over which

the floor is laid. This method makes a neat, clean, tight joint, and avoids any nailing at the floor line.

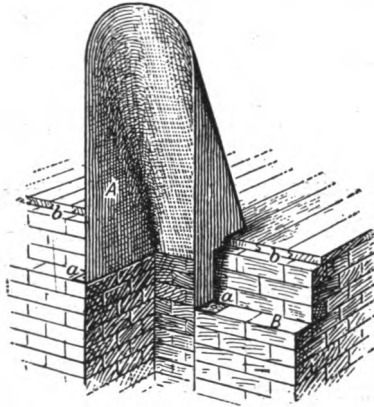

Fig. 151—Sectional View of Airtight Sheet Metal Connection to Brick Flue

When sheet metal ceiling ducts are to be connected, airtight, to vertical brick flues, this connection is made

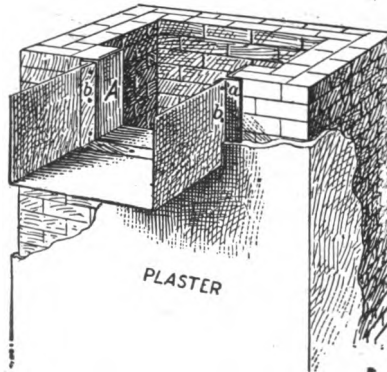

Fig. 152—Sectional View Showing Sheet Metal Ceiling Duct, Connected Airtight to Vertical Brick Flue

as shown in Fig. 152, in which A shows the formation of the collar fitting into the brick opening, this collar being riveted to the duct at **b b**, before connecting to the brick flue. After the connection is made, a wire nail can be driven through the flange into the brick joint at **a**. When the connection is completed and the plaster is put in place, the joint between the metal duct and brick flue will be airtight.

Connecting Collars to Round Pipes

When round pipes are to be connected to round pipes, as in a blower system, the connections are made as shown by the diagrams in Fig. 153, in which B

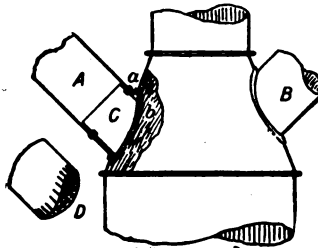

Fig. 153—Method of Flanging Round Collars to Round Pipes in a Heating or Ventilating System

shows the appearance of a finished connection between a round pipe and tapering joint, and A the constructional view. After the proper size opening has been cut in the tapering joint, the pipe A is first flanged outward, as shown by **a**. A collar, C, is then riveted to the pipe A, allowing it to project one inch beyond the flange of the pipe, and notching same at intervals, thus giving the appearance shown at D. The connection is now passed through the opening in the tapering

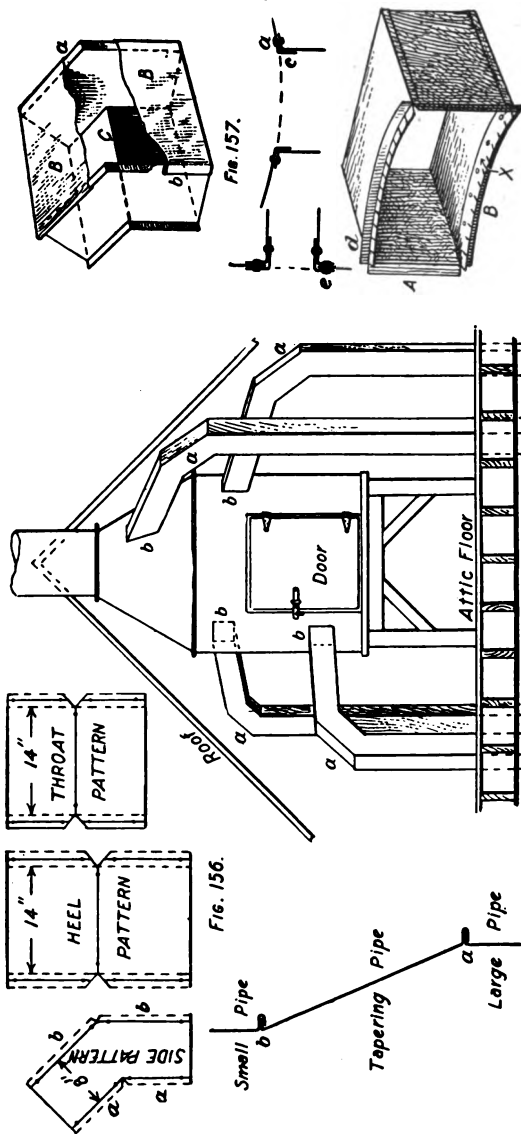

Fig. 154—Method of Double Seaming Tapering Joint
 Fig. 155—Layout of a Rectangular Two-Piece 45° Elbow
 Fig. 157—Method of Seaming Corners in a Two-Piece Elbow
 Fig. 158—Method of Flanging and Connecting Square or Rectangular Pipes to Round Drum

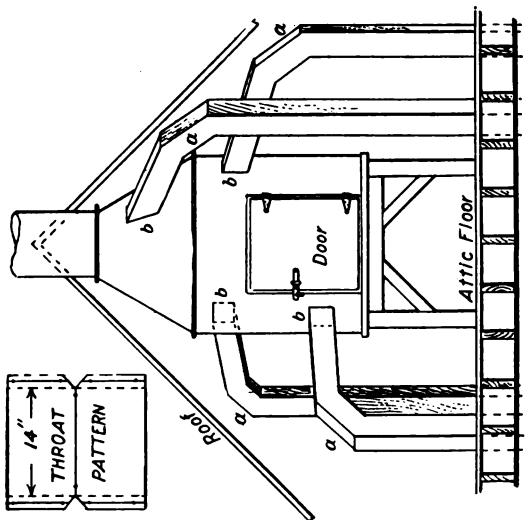

Fig. 155—Connecting Vent Pipes from Attic Floor to Drum

Fig. 154—Method of Double Seaming Tapering Joint
 Fig. 156—Layout of a Rectangular Two-Piece 45° Elbow

joint and the notched flanges turned over as indicated by **b**. This holds the collar firm and secure.

The tapering joint is double seamed to the large and small pipes, as shown by **a** and **b**, in Fig. 154.

Constructing Rectangular Elbows

When the brick flues in attic are connected to a sheet metal drum by means of metal ducts, the elbows in the ducts should not have square or 90° angles, but should be broken as indicated by **a, a**, etc., in Fig. 155, and the ends of the ducts connecting with the drum should be at an incline, as indicated by **b, b**, etc., which tends to increase the flow of air.

A sheet metal drum is usually constructed of No. 22 galvanized sheet iron, the tapering part being seamed to the body and the collar, as shown in Fig. 154, at **a** and **b**.

Assuming that two-pieced 45° elbows, say 8×14 inches in size, are required, they may be laid out direct on the sheet iron, as clearly shown in Fig. 156, which shows the side, throat and heel patterns. The side pattern is 8 inches wide, with a single edge for seaming, shown at **a a** and **b b**, while the patterns for the heel and throat are laid out by taking the lengths of the heel and throat from that of the side piece and placing them as shown at the right, making them 14 inches wide, and allowing a double edge for seaming, as shown by the dotted lines outside.

These elbows are set together as indicated in Fig. 157. The sides have the single edge flanged outward, and the heel and throat pieces have the first edge turned all the way over, as shown at **a**. This edge **a** is then locked over the sides and then double seamed and flattened down on the mandrel stake as shown by **b**.

Connecting Rectangular or Square Ducts to Drum

When rectangular ducts or pipes are connected to a round drum, the ducts are flanged and the connections made as shown in Fig. 158, which shows a perspective view of the flanged rectangular pipe. It will be noticed that the part meeting the curved part of the drum is flanged outward, as at *d*, while the side meeting the vertical part of the drum has a straight flange as at *A*. To the curved flange *B* a separate curved strip is riveted, as shown at *X*. Now, when connecting this duct to the drum, flange *A* is riveted to the body of the drum as indicated at *a* in the diagram above, a flange being left on the drum to enter the duct at *c*. The curved flange of the duct shown at *d* is set tightly against the drum, and the notched flange *X*, turned inward as at *e* in the diagram above, after which the rivet secures the three thicknesses of the metal.

Constructing Air Tight Door in Drum

The method of constructing the drum door and frame, also how it is secured to the drum body, are clearly shown in Fig. 159. *A* and *A* show part of the body of the drum, cut out to receive the door frame, with a lap allowed for riveting purposes at *a* and *a*. *B* shows the outer side of the frame, flanged and riveted to the drum body at *b* and *b*. *C* shows the inner formation of the door frame, which is flanged and riveted to the outer side *B* at *c*. The formation of the door proper is shown at *D*, being so formed that a snug fit is obtained against the frame *C*. The door is made in three sections, making the seams at *d d* and *e e*, a wooden core being placed on the inside as indicated by *E*, to give rigidity. The miter of the door

frame is shown by F G, which should be well lapped and soldered. The door is hinged to the frame B by means of galvanized iron hinges shown at H J, J being bolted to the metal on the side, while H is screwed through the metal face into the wooden core. A clasp is made from band iron, as shown by K, with a handle

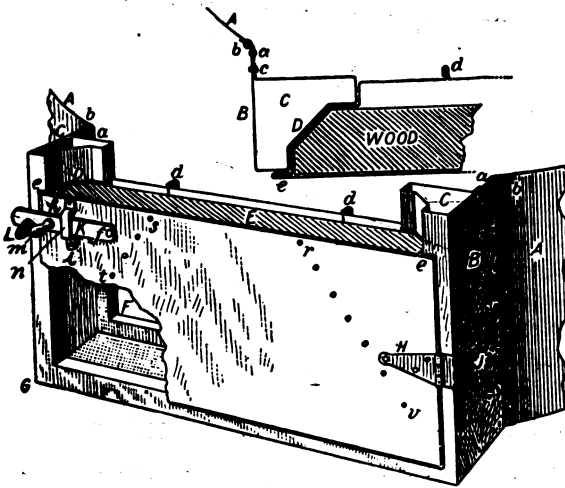

Fig. 159—Construction of Door in Drum

or knob riveted to same at m. A loose wood screw is put in at f, which acts as a pivot when the clasp is raised or lowered. The stop n is fastened at h and i, while the lock L is notched to receive the latch K, and is bolted to the side of the frame. The metal on the face of the door is prevented from buckling by diagonal nailings, as shown at s t and r v. A horizontal section of the door is shown above.

Connecting Curved Branches to Main Duct

When a curve branch is taken from or connected to a main pipe, the connecting joint is constructed as shown in Fig. 160, in which A is the curved branch and B the main pipe. They are connected by means of the locked joint at a b and c. A section through

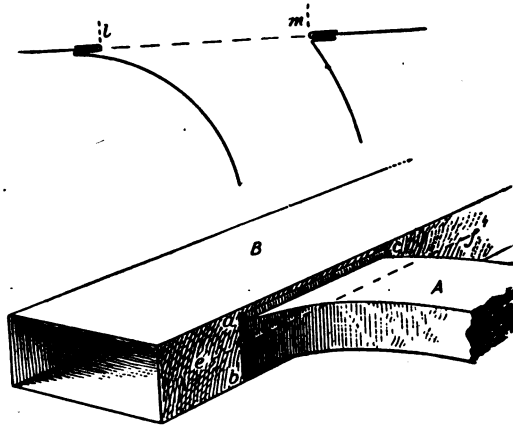

Fig. 160—Connecting Branch to Main Duct

the joint on e f is shown just above, in which the dotted lines l and m show the position of the inner edge after it is inserted in the opening of the large duct, after which it is turned over as shown by the full lines. The joints above and below are constructed in the same manner.

CHAPTER XI.

DUCTS FOR DIRECT-INDIRECT HEATING

Constructing Wall Ducts

In direct-indirect heating the fresh air from outdoors is taken in below the radiator and heated before it passes into the room. Fig. 161 shows how the duct for the entrance of the air is constructed. The proper

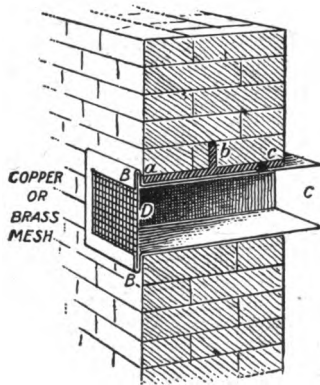

Fig. 161—Method of Constructing Wall Duct in Direct-Indirect Heating

opening is left in the wall, by means of the lintel *a b c*; the duct is then formed as shown by *B C*, having a lock all around the outer face as shown by *B B*, into which copper or brass mesh is placed, so as to keep out insects or any other foreign substance. The duct should be of sufficient length at *C*, the inner end, to allow connection with the radiator beyond the wood

trim as shown. The base of the radiators usually has two dampers, so that by pressing down a treadle it closes the damper towards the room and opens the one which admits fresh air from the outside. When the inner treadle is raised it closes the damper which supplies the outer air, and opens the damper which allows the circulation of the cold air near the floor in the room. If the duct is made of galvanized iron, then number 16 gauge should be used, painting it well with red lead inside and out before setting, to avoid rusting, or if the cost is not to be considered, 24-oz. cold rolled copper can be used.

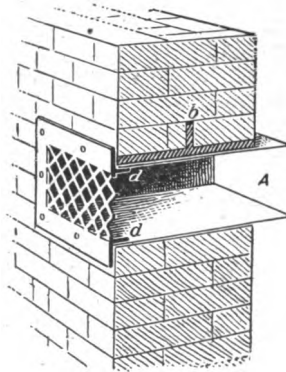

Fig. 162—Construction of Wall Duct, Using a Register Face

When a cast iron register face is used at the outside end of the duct, it is only necessary to employ a tube or duct of the proper length, as indicated by A in Fig. 162. The flanges *d d* of the register face are allowed to enter the outer end of the duct and the face is fastened to the brick wall by a few brass screws, used in connection with screw anchors as previously described.

Wall Duct with Metal Louvres

When the wall duct is to have metal louvres and mesh frame, this is constructed as shown in Fig. 163. The upper part of the frame is formed as indicated by A B and the lower part as shown by C D, with the lower louvre attached at C, the louvres e and f being riveted at the ends. The mesh frame is formed as shown by E F, the flanges being riveted to the duct. Into the grooves of this frame the brass or copper mesh G is inserted.

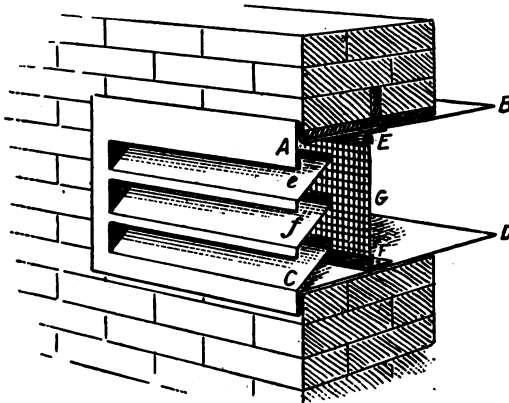

Fig. 163—Construction of Wall Duct with Metal Louvres and Mesh Frame

A cast iron wall box, with louvre slats and netting attached is sometimes employed as shown in Fig. 164. This box is built into the wall by the mason, and if desired, a sheet metal duct can be connected to the same as shown.

Another style of duct, in which the opening is protected by a hood which keeps out the rain and snow, is shown in Fig. 165. The fresh air comes in as shown

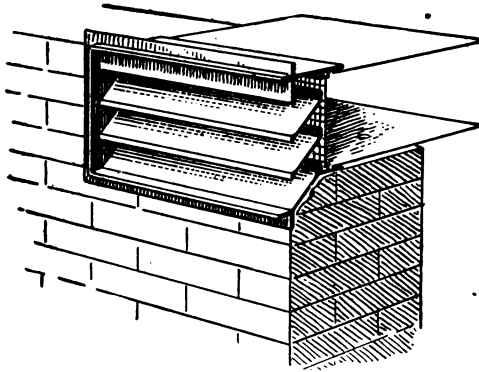

Fig. 164—Cast Iron Wall Box with Louvres and Netting

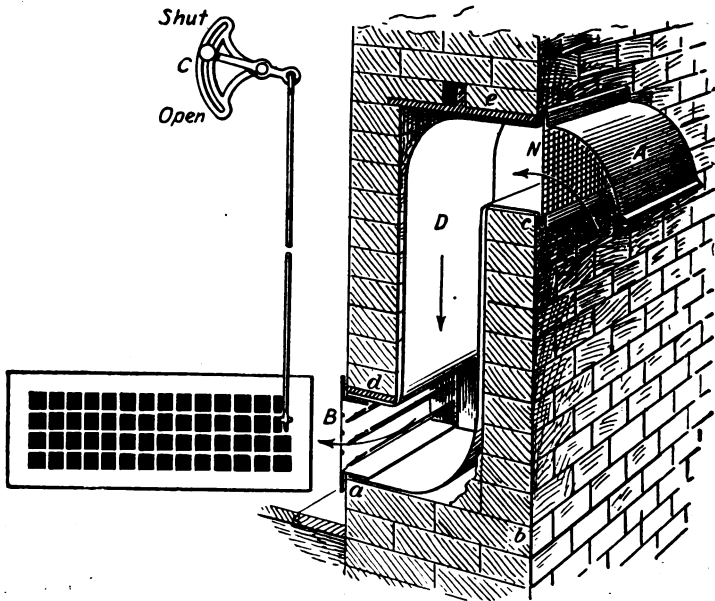

Fig. 165—Method of Constructing Duct for Bringing Outside Air Beneath Radiator in a Direct-Indirect System of Warming

by the arrows, passes down the flue and through an adjustable damper, shown at B. The elevation of this damper is shown at the left. It is operated by the brass rod and quadrant C, by which to open and close the same to suit the amount of fresh air required.

Lining Wall Flue

Sometimes there are objections to a bare brick flue, on account of the dampness which may penetrate through the wall. In that case the entire wall flue should be lined with heavy galvanized iron, painted, or with heavy sheet copper, constructing the duct with rounded corners, as shown. The entire duct or flue D should be made in one piece, with the hood A attached, N indicating the brass netting. Accurate dimensions, as a b and b c, must be obtained before the duct is made up, and after the wall has been built up as high as a b, the duct D is set, and the wall continued, protecting the metal by means of the lintels d and e. The adjustable damper B can be connected at any time before the radiators are set.

Casings for Indirect Radiation

Where there is an objection to placing radiators in the rooms, an indirect system of warming can be installed, as shown in Figs. 166 and 167, in which the radiator is hung below the cellar or basement ceiling and incased by a portable galvanized sheet iron casing. The top of the radiator should always be hung not less than 10 or 12 inches below the ceiling line, and the bottom of the sheet metal casing should be about 10 or 12 inches below the radiator to allow for circulation of air. The cold outer air enters the sheet metal casing through the duct A at the bottom in Fig. 166,

and is warmed by passing over the radiator before it enters the room above. The cold air can be made to enter the top of the casing, as shown in Fig. 167 by placing a metal partition in the position shown by L, which deflects the cold air to the bottom of the casing and allows it to be warmed, as before, by passing over the radiator. In constructing the casing all joints are locked and bolted so as to allow the casing to be easily

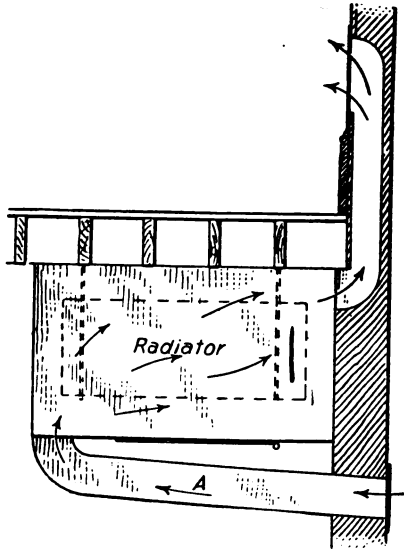

Fig. 166—Method of Indirect Warming by Enclosing Radiator in Sheet Metal Casing, Cold Air Duct Entering at Bottom

taken apart in case repairs are needed to the radiator. Clean out slides are placed in the bottom of the casing, as at a, also in the bottom of the cold air flue, as at b, which allows the duct and casing to be cleaned from dust and dirt when required.

When it is desired to warm cold air from the outside, as well as the cold air from the hall, the ducts are constructed similar to that shown at the right, in Fig. 167. A floor connection is made to the cold air inlet as shown, in which an adjustable damper is placed, as shown by *c*, operated by a chain from the inside of the hall at *d*. If a rotary circulation of the

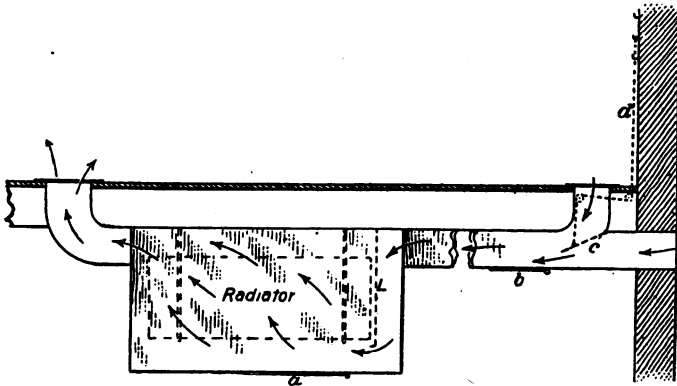

Fig. 167—Another Form of Casing Wherein Air Enters at Top, Showing How Cold Air From Halls as Well as How That From Outside Is Heated

air in the room or hall is desired, the damper is raised to the position shown, whereby circulation of the outer as well as the inner air is obtained, as indicated by the arrows. If only outer air is desired, the damper can be raised until the floor connection is closed, and if the inner cold air alone is to be circulated, the damper *c* can be dropped, thus closing the cold air inlet from the outside.

CHAPTER XII.

CONSTRUCTION OF CASINGS FOR INDIRECT HEATING

There are no standard styles in the shape and construction of casings, they being determined by the location of the indirect radiator, the position of the cold air inlet as well as the position of the register. These form the basis of measurements in the construction of the sheet metal work. To illustrate this Fig. 168

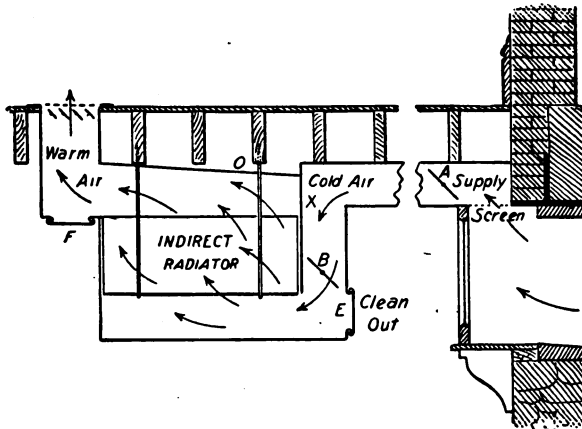

Fig. 168—Cross Section of Indirect Radiator and Floor Register with Cold Air Box Running to Cellar Window

shows a cross section of an indirect radiator and floor register with cold air box running to cellar window, and shows also the conditions which are apt to arise in any building. In this case the cold air supply is

obtained from the top of the cellar window which has been screened. The air is deflected to the under side of the radiator by the partition X. After the cold air is warmed by passing over the radiator it is carried to the room above by the oblique metal top O. Dampers for shutting off the cold air supply are placed at A, which can be operated from above, while another is placed at B, which can be operated from the cellar. Clean out slides are placed at E and F. Dust filters made from cheese cloth set in metal frames are sometimes placed in the cold air supply duct and will form another topic as we proceed.

Casings with Single Walls

Simple methods are employed in the construction of sheet metal casings having single walls as shown

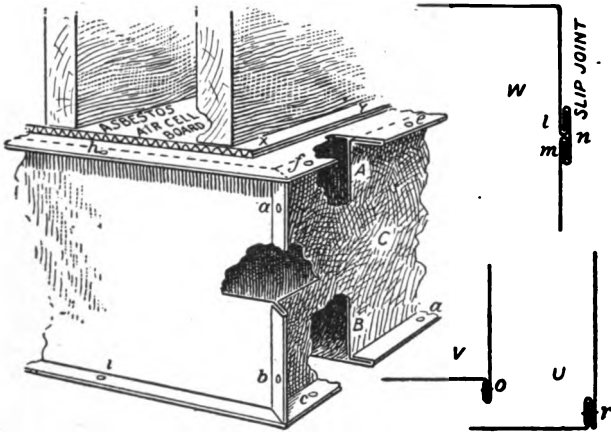

Fig. 169—Construction of Sheet Metal Casings, Single Walls, for Indirect Warming

in Fig. 169. In the views here given A shows the top of the casing and B the bottom, which are locked to the single side wall C as shown. The corners of the

side walls can also be locked as shown and the entire casing secured by means of 3-16 inch round head bolts, which allow the casing to be easily taken apart, when repairs are required to the radiator. These small bolts should be of brass, placed at intervals of 12 inches apart, as indicated by the small letters from a to i inclusive. Sometimes before the top of the casing is put in place, asbestos air cell boards are first fastened to the timbers as shown at X Y. Should the casings be very deep, the sides can be made up of two sections as shown in diagram W, with a lock at l and m joined by the slip piece n. Two other methods of holding the bottom of the casings are shown in diagrams U and V, which require bolting or wiring at r and o respectively.

Various Forms of Vertical Joints

Other forms of vertical joints are used as shown in Fig. 170 by A and B. In the former the joint is bent

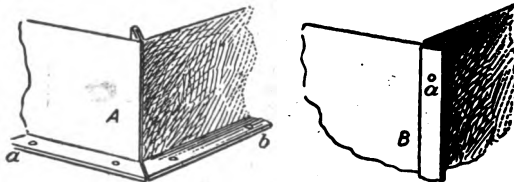

Fig. 170—Two Other Styles of Vertical Corner Joints

toward the inside and held in place by means of the bolts in the bottom at a, b, etc. In B the joint is made similar to the top and bottom joints in Fig. 169 and bolted at a.

By a little thought and study various styles of locks can be constructed, four different shapes being shown in Fig. 171. That at A has a double lock with a hem edge on the outside, the side wall having a raw edge

at the top and bolts are placed at *a* and *b*. C shows another style of lock, in which the side wall has a raw edge at the top. D shows a formation, in which the side wall has an angle bent on same to make the connection, while E shows a form in which the side wall contains the lock and slips over the raw edge of the top.

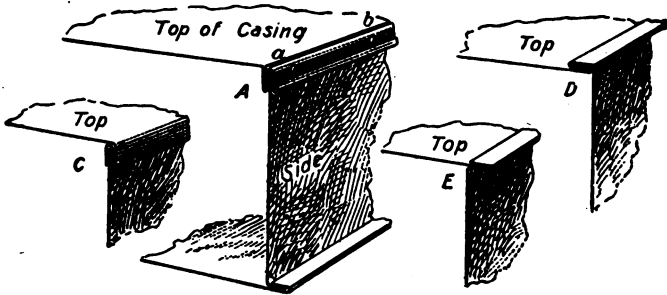

Fig. 171—Other Forms of Casing Construction, Single Walls

When a double lock is required on the corner joints in the side walls it can be constructed as indicated in Fig. 172 with a single edge on the end being slipped into the double edge of the side wall as at A and bolted at *a* and *b*. Sometimes the entire four sides can be set together stationary, being only bolted at the top and bottom of the casing. In this case no bolts need be used on the vertical joints, the corner joint being made as indicated in diagram B, in which the double lock is formed on one side of the casing and a single edge on the other side C. After C has been slipped into B, the small edge *c* is turned over against the side C as indicated in diagram D at *d*.

Four simple forms of corner joints are shown respectively by E, F, H and J. In diagram E one of the simplest forms is shown. In this the lock is bent on one

side and a right angle edge on the other as shown by **e**, with a bolting at **n**. In diagram F is shown another style, with a slip piece locking over the edges at **f f**, in

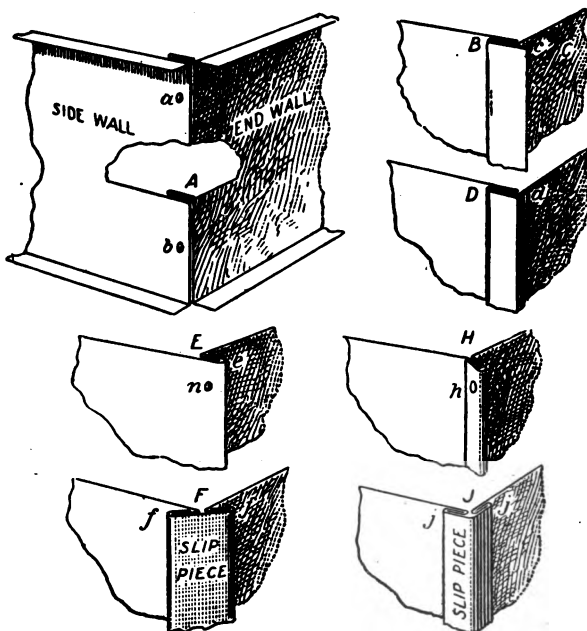

Fig. 172—Various Forms of Vertical Corner Joints in Sheet Metal Casings

which case no bolts are necessary. In diagram H a simple slip is used which requires bolts through as at **h**, etc. In diagram J is shown a good strong corner, which requires no bolting, the angular slip piece locking to the sides at **j j**.

Bending the Double Locks

When bending the double locks just described in diagrams B and D the operations are performed on

the bending brake as shown in Fig. 173, in which it is assumed that A is the shape of the double lock desired. The various bends are referred to by the numbers 1, 2 and 3 as shown. The first operation is shown in B. Place the sheet in the brake, close the top clamp e on dot 2, and raise the bending leaf f so as to make the angle at 2 a little more than square, as shown by a.

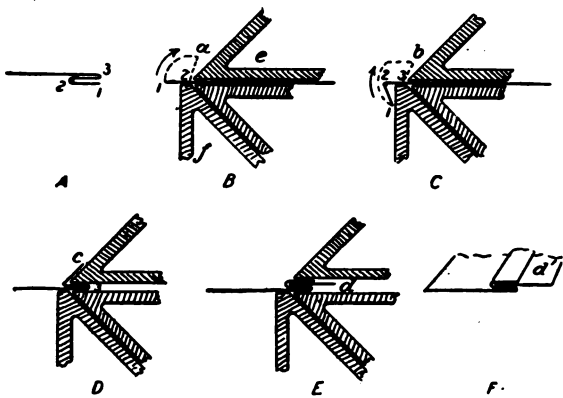

Fig. 173—Bending the Corner Lock

Reverse the sheet as at C, close the top clamp on dot 3 and raise the bending leaf as far as it will go, as indicated by 3 b. Now turn the sheet around and close the bend 3 as shown in D at 3. Place a strip of metal between c and 3, of the required length, and press down c as shown in E, d representing the strip of metal referred to. When this has been done the sheet will appear as shown in diagram F, after which the strip of metal d' can be removed.

CHAPTER XIII.

ASSEMBLING CASINGS AND CONSTRUCTING AIR FILTERS

Casing with Air Space

A simple method of construction which gives an air space between the inside and outside metal walls so as to avoid heating the cellar is shown in Fig. 174. Make

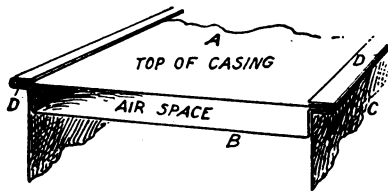

Fig. 174—Constructing Top of Casing with Double Walls, Giving Air Space

the air space as wide as required and add a lock to B which holds the top of the casing A as shown. Form the side wall C as shown, which locks over the lock previously made at D. This same method can be applied to the bottom and sides. If desired the air space can be filled with asbestos.

Angle Iron Frame for Casing Top

To stiffen and strengthen the top of the casing, a wooden frame is sometimes placed on the inside, made of 1x3 inch wood strips covered with galvanized iron; but more often an angle iron frame is used, as shown in Fig. 175. The holes in the top at a a, etc., are for

fastening it to the beams, and the holes at **b b**, at the sides are for fastening it to the sides of the casing.

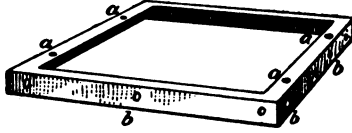

Fig. 175—Angle Iron Frame for Inside of Top Casing

Assembling the Casings

The usual method of putting up the casings, whether the beams are of wood or iron filled with concrete, is to—

First, decide where the radiator is to be located, then to fasten the upper part of the casing in its proper position by nailing or screwing it in place, as this part remains permanent and supports the remainder of the casing. If the beams are of wood and a wooden frame is used inside of the casing, this can be nailed or screwed to the beams. If the beams are of iron and filled with concrete and an angle iron frame is used inside of the casing, then the angle iron frame would

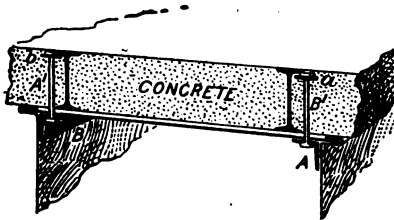

Fig. 176—Using the Angle Iron Frame Inside of Top Casing

be fastened as shown in Fig. 176, fastening the angles **A B** by means of the bolts **A1** and **B1** which pass

through the concrete as shown, and have large washers below the nuts at **a** and **b**. Holes having been previously punched in the top of the casing, the hangers are fastened with lag screws into the beams or cross headers if they are necessary, if they are of wood. If the beams are of iron filled with concrete, then large bolts are passed through the concrete or fire proof blocks and bolted over large iron washers on the top of the floor. After the hangers are in place, and the radiator set, and steam connections made, the various sides, inner partitions and bottom of the casings are then locked or bolted together.

Clean Out Slides and Doors

When the clean out under the casing is made in the form of a slide and sliding groove it is constructed, as clearly shown in the sectional view in Fig. 177, in which **A** represents the slide and **B** the sliding groove.

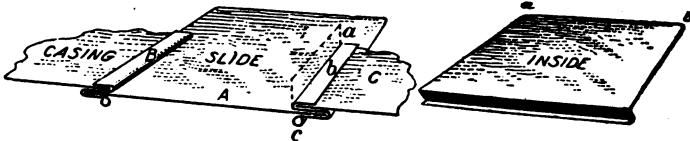

Fig. 177—Sectional View Through Clean-Out Slides

Fig. 178—The Slide Complete

This groove is first bent in the manner shown by **a**, inserted in the opening which is cut in the bottom of the casing **C**, when **a** is flattened down as shown by **b**. A beaded edge is made at **c** for stiffening purposes. The slide itself should be made of number 16 galvanized iron to insure stiffness, and have a hemmed angle at the outer end to use in grasping it, as shown in Fig. 178, and have the corners rounded at **a** and **b** to prevent the slide from binding when it use. When the clean out is made in the form of a hinged door, it is

constructed so as to insure a tight fit, as shown in the section in Fig. 179, in which A represents the bottom of the casing, B the metal frame, C strips of sheet felt or rubber about one-eighth of an inch thick, clamped tightly into the groove at D. A wired edge is shown

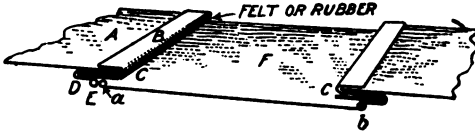

Fig. 179—Horizontal Section Through Hinged Clean-Out Door on Rubber or Felting

at E. F represents the door, which is hinged at b and closes tightly against the rubber or felt by means of the beaded edge a, and is held by means of a turn-buckle, as previously explained.

Duct Connecting Flush with Top of Casing

When the warm or cold air duct is connected flush with the top of the casing, the connection is made

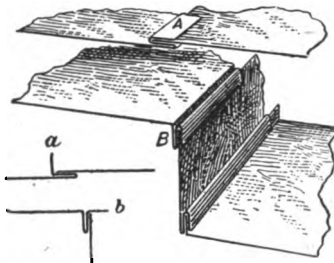

Fig. 180—Connection Between Cold or Warm Air Duct and Casing

as shown at A in Fig. 180, and B shows how the connection is made when the bottom of the duct is at right angles to the side of the casing. Previous to turning

down the locks onto the body of the casing at A and B, the flanges on the duct have the positions shown by a and b in the sketches below.

Lining Cold Air Chambers

Sometimes in place of using sheet metal casings, cold air chambers are constructed of wood and lined with galvanized iron. This lining is done in such a manner that the nail heads will be hidden, so as to prevent the nails from coming out. This method of

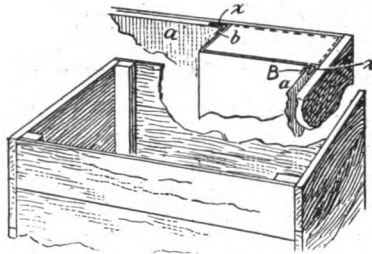

Fig. 181—Method of Lining
Wooden Cold Air Chamber with
Sheet Metal

construction is shown in Fig. 181, in which the metal covering the corner posts is bent as indicated and nailed through the doubled metal at x and x; then after the sheet a is placed in position, the edge b is turned over and tightly closed, as at B. The same method of construction can be used if an internal angle were desired as shown by the dotted lines.

Constructing Cold Air Cleansers

To insure a supply of pure cold air, the cold air duct should be provided with a close mesh screen or brass strainer cloth at its mouth, having about 48 wires to the inch, also a tight-fitting damper, so that the volume

of air may be regulated on a very windy day. To prevent the entrance of dust, etc., by other means than is possible with the ordinary mesh, an air cleanser can be used which is made from cheesecloth similar in construction to that shown in Fig. 182, in which the

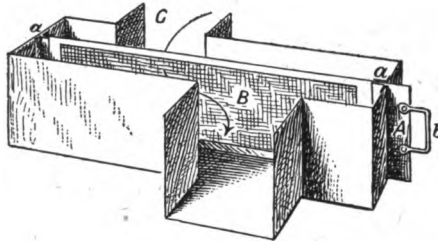

Fig. 182—Single Air Cleanser

outer cold air enters at C, passes through the cheesecloth strainer B and is thus filtered before it passes over the heaters or radiators. The cheese-cloth is fastened to the metal slides A, which runs in grooves

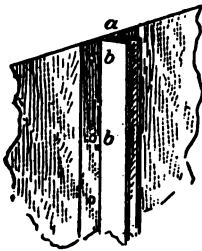

Fig. 183—Groove to Receive Sliding Frames



Fig. 184—Section Showing Metal Frame Cheese-Cloth and Clamping Frame

shown at a and a, having a handle at b for removing for the purpose of cleaning. While brass strainer cloth should be used in place of cheese-cloth, the

cheese-cloth is considered more sanitary because it can be destroyed when dirty and replaced.

The grooves for the slides are formed and fastened by being bent as shown by *a* in Fig. 183 and riveted through flanges against the sides of the duct at *b b*.

In Fig. 184 is shown a sectional view of the metal frame carrying the brass mesh or cheese-cloth and the clamping frame. The frame *A* is made of the proper size, riveting the corners to insure stiffness. The top, bottom and end which enters the duct have equal margin, but the end to which the handle is riveted is of sufficient width to insure the proper

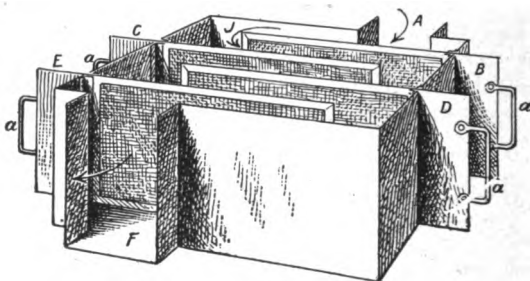

Fig. 185—Quadrupled Air Cleanser, Using Cheese-Cloth on Metal Frames

size opening on the inside, as indicated in Fig. 182. When brass cloth is used as a cleanser, the frame *A* in Fig. 184 is all that is required, over which the brass cloth is fastened as shown at *B*, and remains permanent, and in cleaning, is thoroughly brushed. When cheese-cloth is used, it is also folded over the metal frame *A*, but held in position by means of a binding clamp *C*. This clamp is made in four pieces, one for each side, and fits snugly over the cheese-cloth and frame. When the cloth becomes dirty, the slide is removed, the clamps taken off, the old cloth removed,

and new inserted, over which the clamps are again placed, ready for use. The illustration shown is exaggerated, as to clearly show the construction.

If a more thorough cleansing of air is desired, a quadrupled air cleanser can be installed by using four cheese-cloth slides as indicated in Fig. 185, two on each side placed alternately as shown. The proper size slot is cut into the sides of the chamber, so that the metal frames will slide and yet fit snugly, by using the handles *a a*, etc. The outer cold air entering at *A* must pass through the cheese-cloth filters *B, C, D* and *E*, so that the air becomes thoroughly filtered when it passes through the duct *F* previous to being heated. Even though the cold air should pass around in the direction of *J*, it must always first pass through the cheese-cloths, before it can enter at *F*.

CHAPTER XIV.

THE CONSTRUCTION OF MIXING DAMPERS

Mixing Damper in Indirect Heating

The use of the mixing damper in a galvanized iron casing in indirect heating is shown in connection with Fig. 186, in which A is the heater. The heavy lines show the sectional view of the casing connecting to

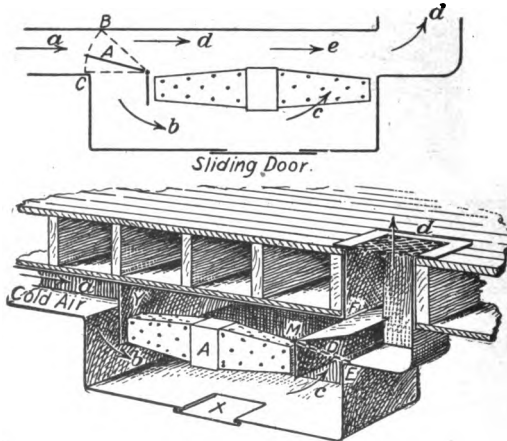

Fig. 186—Galvanized Iron Casing with Mixing Damper Below the Register

the floor register. The cold air duct *a* is carried along the basement ceiling from an inlet window and connects to the cold air chamber below the heater *A*.

The mixing damper in this case has been placed below the register as shown at *D*, and can be raised to

F, or lowered to E. By means of the metal partition Y, the cold air entering at a is brought below the heater at b and if the mixing damper D is lowered to E, then all of the cold air must pass over the heater A and become warmed before entering the room above through the register d. If the damper D, however, is set in the position shown, part of the cold air will pass over the heater A and part will pass without going through the heater, and this mixture entering the register will be at a lower temperature than before. By regulating the damper at the pivot M, the warm and cold air delivered to the room can be mixed as desired. The only objection to placing the mixing damper below the register is, that on a cold, windy day, if the damper is set in the position shown, the air enters the room too quickly, before it can be thoroughly mixed—that is, a stream of warm air passing through the heater will pass through one-half of the register and a stream of cold air c will pass through the other half.

As the distance between the cold air chamber and register is short, the clean out door being placed at X, will be sufficiently near to permit reaching the duct connecting to the register, for cleaning purposes.

The mixing damper if desired can be placed at the opposite side as indicated by A in the diagram above the same figure. In this case if the damper be raised to B, all of the cold air entering at a must pass over the heater as indicated by the arrows b and c and become heated before passing through the register at d. If, however, the damper is set in the position shown by A, the lower stream of cold air will pass over the heater, as shown by b c, while the upper stream passes through as indicated by d e, and becomes slightly heated before passing through the register d. It is

therefore advisable in regulating the mixing damper to have the opening A B larger than the opening A C as shown, so as to obtain the desired temperature.

Damper for Quick Warming

When it is desirable to warm the rooms at times when no ventilation is desired, as at night, or for quick warming in the morning, or any other time, the construction having this advantage is shown in Fig. 187,

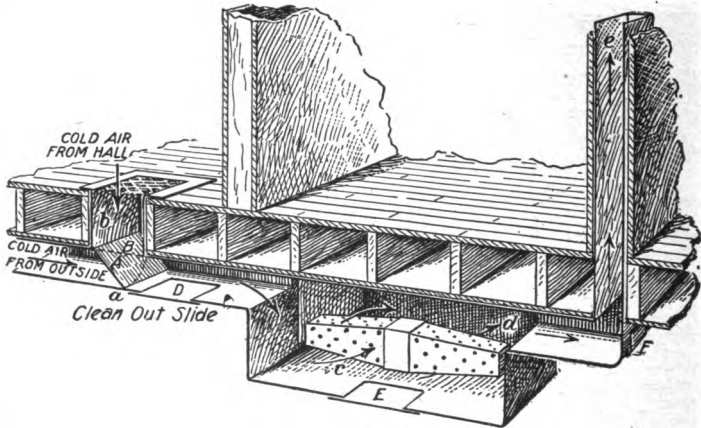

Fig. 187—Method of Construction When Cold Air Either from the Outside or from the Halls Is to be Used

in which the mixing damper is shown by A. If this damper is raised to B, the cold air from the outside will be heated. If, however, the damper A be dropped to a the cold air from the hall will pass through the register at b, enter the cold air chamber at c, pass over the heater at d and up the flue e to the room above. By keeping the damper A in the position shown the same air is heated over and over, but by raising the damper A, fresh cold air and ventilation is obtained.

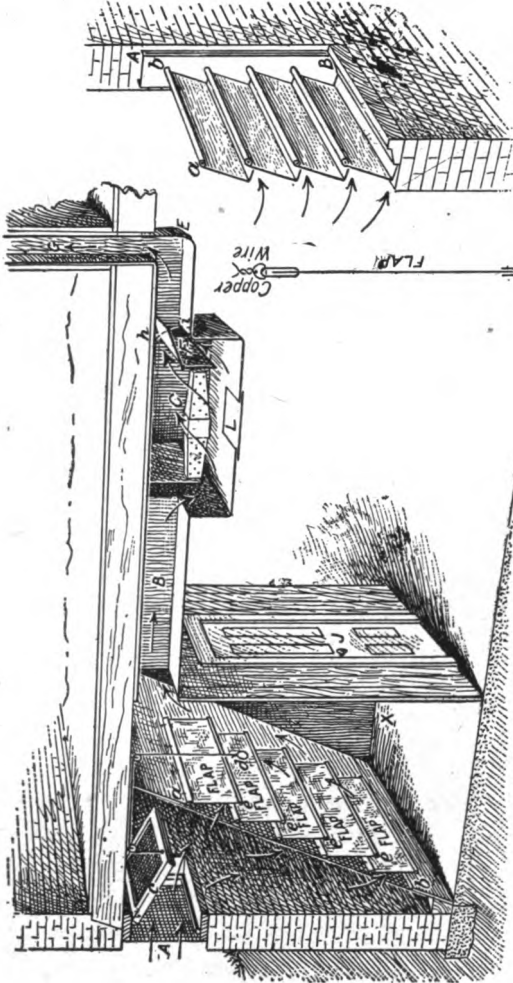

Fig. 189—Re-enforcing the Edges of the Flaps

Fig. 188—Construction of Cold Air Room with Metal Edged Flaps Employed

In a construction of this kind clean out doors should be placed as shown by D, E and F.

Check Valves in Cold Air Room

When a cold air room is in use, as for a large building, with ducts connecting with the heaters, check valves are arranged to prevent a back draft or outward flow of air, as shown in Fig. 188, in which X shows the cold air room, with a door J leading to same. A window at the ceiling line is provided at A with a heavy wire mesh on the outside as shown, or a frame can be hinged on the outside of the window, over which brass strainer cloth or cheese-cloth is stretched for cleansing the air. The window c is hinged on the inside and has a chain attached running over two brass pulleys as shown, so that it can be opened or closed as desired from d. The front of the cold air room has a partition sloping from the ceiling to the floor, with an opening in it as indicated from a to b, over which one-half inch wire mesh is drawn. To this wire mesh the check valves indicated by e, usually called flaps, are fastened. These flaps are usually made about six inches wide, overlap each other about one inch and hang in a perpendicular position as shown, thus allowing the air to enter the cold air room and pass thence through the duct B, over the heater C and up the flue G. In this case the mixing damper has been placed at F, and can be regulated by being moved to h or i. The objection previously noted about placing the mixing damper at this end of the heater is overcome when a vertical flue is used, because the cold and warm air will mix more rapidly in ascending the flue G. The flaps e e, etc., being made of gossamer cloth, swing easily, so that if there should be any tendency to a

back draught or outward flow of air, the flaps will close against each other and prevent the same. Clean outs are provided at L and E.

Construction of Flap

As shown in Fig. 189, a V-shaped metal hem is clamped at the lower edge of the flap, and a wider one at the upper part. At intervals of from 10 to 12 inches, holes are punched and through these holes, soft copper wire loops are placed and fastened to the wire mesh previously mentioned. In this manner the flaps are hung in position and can turn inward or outward according to the air pressure.

Louvre Construction in Cold Air Inlet

When the inlet to the cold air room is to have metal louvres the frame is constructed as shown in

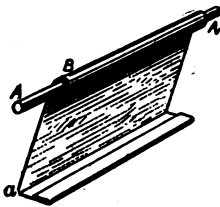

Fig. 191—Formation of Movable Louvre

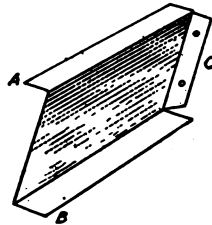

Fig. 192—Formation of Stationary Louvre

Fig. 190, which is a sectional view of movable metal louvres closed. Sometimes, however, stationary louvres are employed. In either case the part of the frame shown by A B is constructed of number 22 galvanized iron. When movable louvres are used they are pivoted on rods a, which enter holes previously punched in the frame at b.

They are formed as shown in Fig. 191, in which the sheet metal B is turned over the rod A A, which should not be less than $\frac{1}{4}$ inch in thickness, and acts as the pivot. To stiffen the lower edge, a hem edge can be formed at a.

When the louvres are to be stationary they are constructed as shown in Fig. 192, right angle bends being made at A and B, to which a hem edge can be added if desired. If the louvres are longer than two feet, they should be made from number 22 galvanized iron or from 16-oz. cold rolled copper. A flange must be allowed at each end, turned toward the inside as

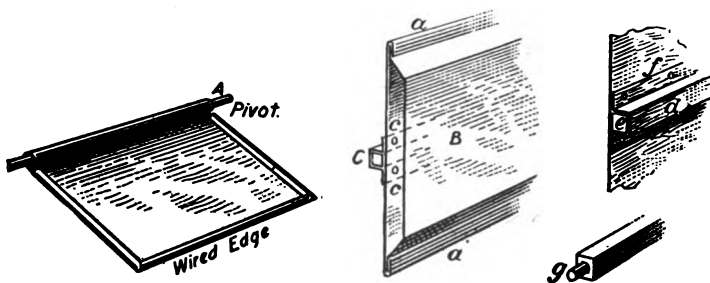

Fig. 193—Construction of Double Damper

Fig. 194—Construction of Double Damper

shown by C, which is riveted to the frame before it is inserted in the wall opening.

Construction of Mixing Damper

The construction of the mixing damper is shown in Fig. 193; the top edge of the damper is turned over a rod not less than $\frac{1}{4}$ inch in thickness, which acts as a pivot when placed in the sides of the casing. The other three sides of the damper have hem or wire edges. Care must be taken that the mixing damper works easily and closes tightly against sheet rubber

or felt flanges, similar in construction to those already described. The dampers can be operated from the rooms above by means of brass chains passing over guide pulleys as previously shown, or a quadrant can be operated from the side of the casing in the basement.

Construction and Operation of Duct Dampers

When square or rectangular dampers are to be operated in heat or vent ducts, the method of con-

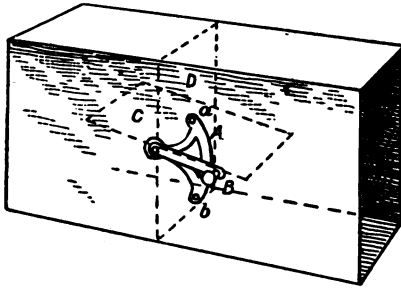

Fig. 195—Using the Quadrant for Operating Center or Mixing Damper

struction required is that shown in Fig. 194, in which a double damper is shown. The top B, or one side,

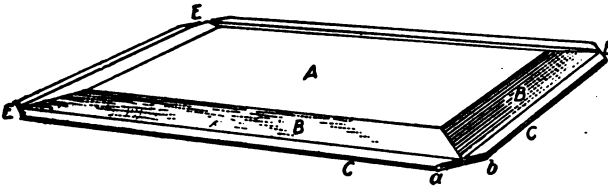

Fig. 196—Method of Notching Corner of Double Damper to Prevent Binding in Duct

is beveled as shown, while the other side is flat with locks, which close over the edges at *a* and *a*. On the flat side of the damper a pocket *C* is riveted as shown

by *c c* to receive the damper rod; this rod pocket *C* must be riveted to the flat side before the opposite side is locked in position. The diagram at the right shows the flat side of the damper, showing more clearly how the damper rod *e* is fitted into the pocket *d*, which in turn is riveted at *f*.

The ends of the damper rod are filed as at *g* below, so that they act as a pivot when in position in the sides of the duct.

In operating the dampers after they are placed in the duct, quadrants are used as shown at *A* in Fig. 195. These quadrants are riveted in position at *a* and

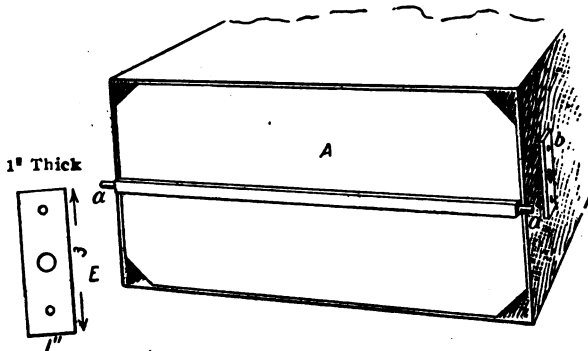

Fig. 197—The Damper in Position

b, and the end of the damper rod secured to the handle *B*; then by means of the handle the damper can be closed or opened as shown by the dotted lines. Care must be taken that the dampers close tightly against felt or rubber flanges as previously illustrated. When using sheet metal dampers they are formed so as to prevent them from binding in the duct as shown in Fig. 196. In this cut *A B B* represents the beveled side of the damper with single edges turned outward

as shown by **a b**. **C C** shows the lock to lock to the beveled side as shown. The corners are notched off at 45° as shown by **E E E**, which prevents binding in the duct. When this damper is in position in the duct a re-enforcement is required to the metal side of the duct to receive the damper rod as shown in Fig. 197. **A** shows the damper in position and **a a** the damper rod. Small eyelets are used through which the damper pivot passes, as shown by **b** and as shown in detail with measurements at **E**. The eyelet is riveted to the sides of the duct through the two holes near the ends and the rod pivot passes through the center hole.

CHAPTER XV.

MAKING DAMPERS FOR LARGE DUCTS

Dampers for Large Ducts

When dampers are required in large size ducts, where they cannot be made in one piece, they are then made in the form of louvres as shown in Fig. 198, and are constructed as follows: First a wrought iron frame is made, whose outside measurements will

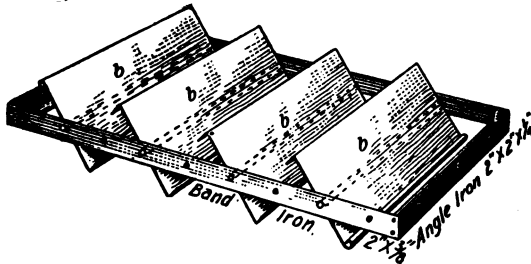

Fig. 198—Louvre Dampers for Large Size Ducts

fit the inside of the duct, two sides being of angle iron and two of flat iron of the thickness given in the illustration. This wrought iron frame has holes punched as indicated on all sides, through which it is riveted to the inside of the duct. Galvanized sheet iron louvres made of No. 20 gauge metal are then formed up as indicated by *b* through the center of which pivots are fastened, as previously illustrated, the ends of the pivots passing into holes punched through the band iron.

Operation of Louvre Dampers

The louvre dampers are operated as shown in Fig. 199. Malleable iron brackets *b*, which can be purchased from dealers in gearing supplies are riveted to the louvres and pivoted to a flat piece of band iron *e*, *e* as shown. Suitable sized pulleys *X* and *X* are fastened by bolting or riveting through to the

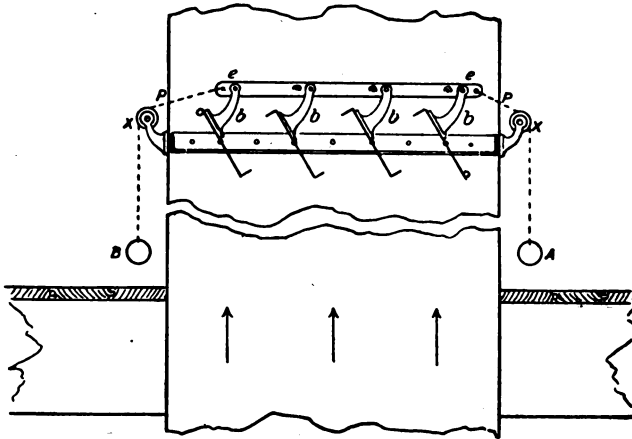

Fig. 199—Operation of Louvre Dampers

angle iron frame as shown. Brass chains pass over the pulleys through a slot cut into the sides of the duct at *P*. By pulling the ring at *A* or *B* the damper can be opened or closed.

Fusible Damper Construction

What are known as fusible dampers are usually employed in the fresh air and exhaust ducts. These are, as their name implies, dampers normally held open with a fusible link, which is melted when the temperature reaches 155°. They are placed in the duct at each floor as shown in Fig. 200, so that in

case of fire on any floor the link holding the damper on the floor above melts and allows the damper to close, thus checking the circulation of air.

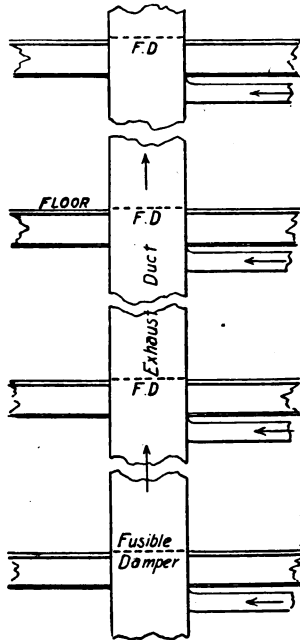

Fig. 200—Location of Fusible Dampers

These fusible dampers are constructed as shown in Fig. 201, in which A represents the duct, B, C an angle iron frame riveted to the inside of the duct, and D the damper, which is made of $\frac{1}{8}$ -inch thick metal and has a band iron frame riveted around same as indicated by **b b**. A pivot is placed at either end and a weight is bolted to the upper edge of the damper. The fusible link shown consists of two pieces

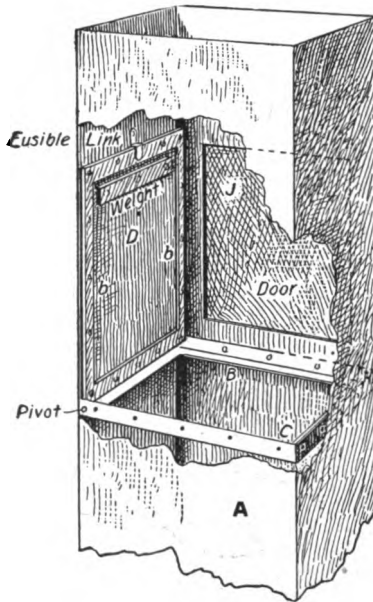

Fig. 201—Construction of Fusible Dampers

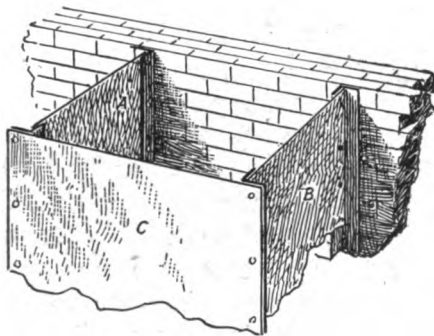

Fig. 202—Construction of Duct for Outside Vent

of metal soldered together with an alloy which will melt and release the damper at 155°. In order that the dampers can be inspected and adjusted when necessary, doors are provided at each floor as at J, which can be opened from each floor and closed tightly.

Fusible Alloy and Links

An alloy for a solder melting at 155° is composed of 12 parts of tin, 25 of lead, 50 of bismuth and 13

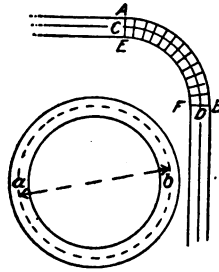

Fig. 203—Riveting Vertical Joints in Heavy Stacks

of cadmium. Fusible links for the purpose can be purchased.

Duct for Outside Vent

When the vent or exhaust duct is placed on the outside of the building the duct is constructed by means of angle iron uprights, to which heavy galvanized iron sheets are riveted as shown in Fig. 202, in which the angle iron uprights against the wall are fastened by expansion bolts. The outer uprights are held in position by means of cross-angle pieces, secured to the uprights against the wall. Holes are punched in the angle irons to receive the rivets before the uprights are set in position and when rivet-

ing the galvanized iron sheets in place the sides A and B are riveted in position first. This leaves the front open and avoids climbing in and out of the

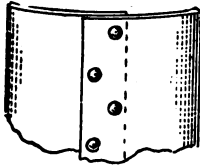

Fig. 204—Riveting Joints for Stacks

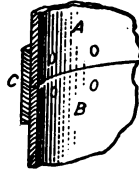

Fig. 205—Cross Joints

duct. After the sides are in place, the front C can be riveted in position from the outside by placing the angle uprights in the position shown.

Joints for Stacks

The usual metals employed for round stacks are black and galvanized sheet iron in thickness from No. 24 to 16 gauge; the joints being usually riveted as shown in Fig. 203.

*When black sheet iron is used for the stack, the varnish used to protect the metal from rusting is made up from good asphaltum dissolved in oil of turpentine, and the inside of the stack is varnished or painted by means of a 4-inch wide painter's brush to which a long handle is attached. Several excellent brands of sheet metal are to be had for this special class of work.

Forming the Stack

When the metal is rolled, to form a stack or other cylindrical article the outer molecules expand along the outer curve A B of Fig. 204, while those along

the inner curve E F contract as shown, the center of the thickness along C D remaining practically stationary. This then shows that if no allowance were added to the circumference for the thickness of the metal the inside diameter would be too small. It would thus be found that the desired diameter would measure from center to center of thickness as shown in diagram from a to b.

Vertical joints are riveted in heavy stack work by placing the rivet zig-zag fashion as shown in Fig. 204. The cross joints are made in heavy stack work as shown in Fig. 205. An outer collar or band C is riveted on the outside of the pipe as at B, then the following joint of pipe A slipped in position, and the band C riveted to A.

Punching Holes in Heavy Material.

As heavy metal necessitates that all holes be punched in the pipe and band while in the flat sheet, that is before rolling, their exact position can be de-

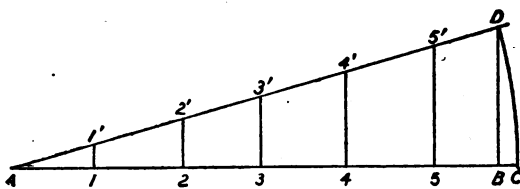

Fig. 206—Finding Position for Punching Holes, While Sheet Is in the Flat

termined by means of the diagram Fig. 206, whether they are equally or unequally spaced, in the following manner. Let A B represent the outside girth of a stack made from $\frac{1}{4}$ -inch thick metal, and let the small figures 1 to 5 represent the unequally spaced holes. To find the location of the holes in

the band on its true girth, add seven times the thickness of the metal or $7'' \times \frac{1}{4}''$ or $1\frac{3}{4}''$ as shown from B to C. From B erect a perpendicular, intersecting it at D by an arc struck from A as center and A C as radius. Draw a line from D to A, and erect perpendiculars from points 1 to 5 until they intersect A D at 1' to 5'. Then A D with the various intersections on same is the layout of the holes for the band going around the outside of the stack.

Another form of cross joint can be made by placing the band on the inside of the stack as shown in Fig. 207.

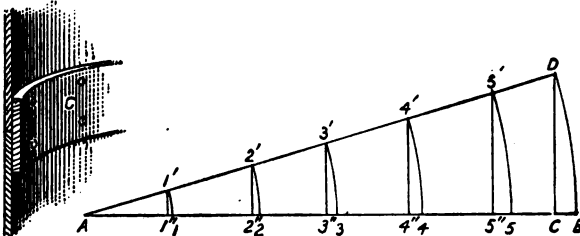

Fig. 207—Another Form of Cross Joint

Fig. 208—Method of Finding Girth of Inside Band

For punching the holes in the flat band going on the inside of the stack the difference in girths is deducted from the circumference of the stack as shown in Fig. 208. Let A B represent the inside girth of the stack and points from 1 to 5 the location of the holes. As the band is to go on the inside of the stack, then we deduct $1\frac{3}{4}$ inch from B to C, and at C erect a perpendicular, intersecting it at D by an arc struck from A as center and A B as radius. Draw a line from D to A, and using A as center, with radii equal

to the distances from A to the several points 1 to 5, draw arcs cutting the slant line D A as shown from 1' to 5' respectively. Now from the various intersections 1' to 5' draw lines at right angles to A B intersecting the same from 1" to 5". Then the line A C with the various intersections 1" to 5", will be the layout for the band going on the inside of the stack.

Re-enforced Angle Iron Cross Joints

The cross joints may be re-enforced with angle iron

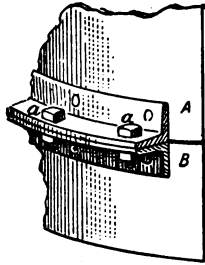

Fig. 209—Re-enforcing Cross Joints with Angle Iron Rings

rings as shown in Fig. 209. The angle iron rings are riveted to the ends of the pieces at A and B, then the joint assembled by bolting the pieces together at a and a.

CHAPTER XVI.

CALCULATING AREAS OF PIPES AND DUCTS

Finding Area of Pipe

The rule for finding the area of a pipe of any diameter is to square the diameter and multiply by the decimal .7854. Thus to find the area of a pipe of 32 in. diameter we have $32 \times 32 = 1024 \times .7854 = 804.25$ square inches. This same result is obtained by referring to the table on areas.

In blower work when a branch is added to a pipe it becomes necessary that the part following should have the combined area of the two. In other words, the diameters of the two pipes being known, the diameter of the third pipe must be such so as to contain their combined area. This unknown diameter can be found without computing by use of a table of areas and circumferences. The method is made clear in connection with Fig. 210, where the first pipe A is assumed to be 20 in., to which a branch C of 12 in. diameter is connected by means of the scalene joint B, thus making the third pipe D equal to 23 $\frac{5}{16}$ in., which contains the combined area of the 12 and the 20 in. pipes. This computation will be found in the table herewith, which contains inches and fractional inches. The table is computed from 10 in., advancing by eighths to 2 ft. $1\frac{3}{4}$ in. The reader is advised to obtain a full table of circumferences and areas from $\frac{1}{8}$ -in., advancing by eighths to 100 in. or

TABLE OF CIRCUMFERENCES AND AREAS OF CIRCLES TO
NEAREST FRACTIONAL MEASUREMENTS

Dia. in		Cir. in		Area in		Dia. in		Cir. in		Area in	
inch.		Ft.	In.	Sq. inch.		Ft.	In.	Ft.	In.	Sq. inch.	
10 in.	2	7%		78.540		17%	4	7%		243.977	
10 1/4	2	7%		80.515		17 1/4	4	6%		240.528	
10 1/2	2	8 1/2		82.516		17%	4	7%		247.450	
10 3/4	2	8 1/2		84.540		17%	4	8%		250.947	
10 3/4	2	8%		86.590		18 in.	4	8 1/2		254.469	
10 3/4	2	9%		88.664		18 1/4	4	8%		258.016	
10 3/4	2	9%		90.762		18 1/2	4	9%		261.587	
10 3/4	2	10%		92.855		18%	4	9%		265.182	
11 in.	2	10 1/2		95.033		18%	4	10%		268.803	
11 1/4	2	10%		97.205		18 1/2	4	10 1/2		272.447	
11 1/2	2	11 1/4		99.402		18%	4	10%		276.117	
11 3/4	2	11%		101.623		18%	4	11%		279.811	
11 3/4	3	0 1/2		103.869		19 in.	4	11%		283.529	
11 3/4	3	0%		106.139		19 1/4	5	0		287.272	
11 3/4	3	0%		108.434		19 1/2	5	0 1/2		291.039	
11 3/4	3	1%		110.753		19%	5	0%		294.831	
12 in.	3	1%		113.097		19 1/4	5	1%		298.648	
12 1/4	3	2		115.466		19 1/2	5	1%		302.489	
12 1/2	3	2 1/2		117.859		19%	5	2		306.355	
12 3/4	3	2%		120.276		19%	5	2%		310.245	
12 3/4	3	3 1/4		122.718		20 in.	5	2%		314.160	
12 3/4	3	3%		125.185		20 1/4	5	3 1/4		318.099	
12 3/4	3	4		127.676		20 1/2	5	3%		322.063	
12 3/4	3	4%		130.192		20 3/4	5	4		326.051	
13 in.	3	4%		132.732		20 1/2	5	4%		330.064	
13 1/4	3	5%		135.297		20%	5	4%		334.101	
13 1/2	3	5%		137.886		20%	5	5 1/2		338.163	
13 3/4	3	6		140.500		20%	5	5 1/2		342.250	
13 3/4	3	6%		143.139		21 in.	5	5%		346.361	
13 3/4	3	6%		145.802		21 1/4	5	6%		350.497	
13 3/4	3	7%		148.489		21 1/2	5	6%		354.657	
13 3/4	3	7%		151.201		21%	5	7%		358.841	
14 in.	3	7%		153.938		21 1/4	5	7%		363.051	
14 1/4	3	8%		156.699		21%	5	7%		367.284	
14 1/2	3	8%		159.485		21%	5	8 1/4		371.543	
14 3/4	3	9 1/2		162.295		21%	5	8%		375.826	
14 3/4	3	9 1/2		165.130		22 in.	5	9%		380.133	
14 3/4	3	9%		167.989		22 1/4	5	9%		384.465	
14 3/4	3	10 1/4		170.873		22 1/2	5	9%		388.822	
14 3/4	3	10%		173.782		22%	5	10%		393.203	
15 in.	3	11%		176.715		22 1/4	5	10%		397.608	
15 1/4	3	11 1/2		179.672		22%	5	11%		402.038	
15 1/2	3	11%		182.654		22%	5	11 1/2		406.493	
15%	4	0%		185.661		23 in.	6	0%		415.476	
15 1/4	4	0%		188.692		23 1/4	6	0%		420.004	
15%	4	1		191.748		23 1/2	6	1		424.557	
15%	4	1 1/2		194.828		23%	6	1%		429.135	
15%	4	1%		197.933		23 3/4	6	1%		433.737	
16 in.	4	2 1/4		201.062		23%	6	2 1/4		438.363	
16 1/4	4	2%		204.216		23%	6	2%		443.014	
16 1/2	4	3		207.394		23%	6	3		447.690	
16 3/4	4	3%		210.597		22%	5	11%		450.972	
16 3/4	4	3%		213.825		2	0	6	3%	452.390	
16%	4	4 1/4		217.077		2	0%	6	4%	461.864	
16%	4	4%		220.353		2	0 1/2	6	4%	471.436	
16%	4	5		223.654		2	0%	6	5%	481.106	
17 in.	4	5%		226.980		2	1	6	6%	490.875	
17 1/4	4	5%		230.330		2	1 1/4	6	7%	500.741	
17 1/2	4	6 1/2		233.705		2	1%	6	8%	510.706	
17%	4	6 1/2		237.104		2	1%	6	8%	520.769	

to 10 ft. Following the first column in diameters of the table herewith to 20 in., we find the area equals 314.160, to which is added the area of the 12 in. branch C, which is 113.097. $314.160 + 113.097 = 427.257$ sq in. Now following the table of areas to the number nearest to 427.257, we find 429.135, whose diameter would equal $23\frac{5}{16}$ in. We therefore reduce this and make the diameter of the third pipe D $23\frac{5}{16}$ in. as shown.

Another method used to find the unknown diameter is by means of the steel square as shown in Fig. 211. On ascertaining the diameter of the two pipes 12

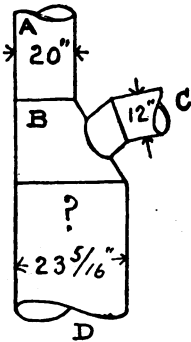

Fig. 210—Finding the Unknown Diameter

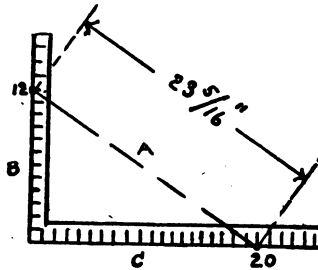

Fig. 211—Finding the Unknown Diameter with the Steel Square

and 20 in. respectively, simply lay the two-foot rule at 12 and 20 on the square, and the distance between will measure $23\frac{5}{16}$ in. This method saves considerable time and is based on the principle that the hypotenuse A contains the square of the altitude B and base C combined.

When the sizes of two given square pipes are known,

the third square size is determined as shown by the diagram Fig. 212. Assume that the first branch is 10 in. square and the second branch 7 in. square. The square of 10 is 100 and the square of 7 is 49,

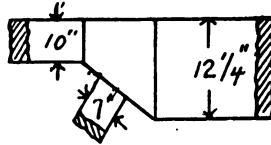

Fig. 212—Finding the Unknown Size of Square Pipe

or a total of 149. The labor of extracting the square root may be avoided by consulting a table of square roots, in which look for the number 149, the square root of which is 12.207 or $12\frac{1}{4}$ in practical work, as shown in the diagram.

Computing Additional Areas

When ceiling ducts in ventilation work are constructed with various branches, all of a given height.

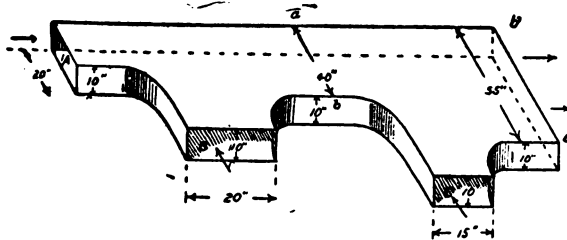

Fig. 213—Computing Areas in Ceiling Vent Duct

the additional dimensions, which must be added to the main duct so that it will contain the additional area of the branch previously added, may be com-

puted, as shown in Fig. 213. A shows the first inlet, which is 10×20 in., to which a branch has been added as shown by B, also 10×20 . As the height 10 in. remains the same throughout the duct, then two times 20 equals 40 in., the width of the duct from **a** to **b**. To this size duct is added another branch 10×15 in. as shown by C. Then $40 + 15 = 55$ in., or the width of the duct from **d** to **e**.

CHAPTER XVII.

VARIOUS TYPES OF VENTILATORS

Much ingenuity has been brought to bear in the designing of ventilators for buildings of various descriptions. Frequent use is made of ventilators that are put out by various manufacturers, many of which are protected by patents. In Fig. 214, Nos. 1, 2, 3, 4 and 5 illustrate simple ventilators that can be made in any shop. The Emerson ventilator shown in No. 6 is a popular form not patented. There are also many forms of revolving ventilators that are not protected by patents. One form of these is shown in No. 7. It is made of four pieces, the pipe, the swing, the conical top and the wing. A steel rod is filed to a point at the top and allows the swing to revolve on a piece of thick glass secured with a notched metal strip on the under side of the cone top.

A ship's ventilator usually has a round inlet and elliptical outlet as shown in No. 8.

Some of the plain types of ventilator heads offered by manufacturers are shown in Nos. 9 to 14. Two examples of the several styles of ventilators with wire glass tops securely imbedded to make waterproof are shown in Nos. 15 and 16. In Nos. 17 and 18 are illustrated how, in two types of ventilators, a self-closing device is installed as a means of fire retarding. It will be noted that the fusible links shown, which melt at a very low temperature; will, in case of fire, melt and automatically close the

damper. Other forms of ventilators with dampers are illustrated in Nos. 19, to 22, in Fig. 214 A. To the chains operating the dampers in these, fusible links can be attached if desired. Various types of revolving cowls and ventilators are shown in Nos. 23 to 29.

In No. 34 is illustrated a ventilator with a fan placed under the cap. This fan is operated by the wind pressure and creates a suction. Another means employed to form suction is shown in No. 31, in which the fan inside the pipe is operated by the revolving of the top. No. 30 shows another patented construction in which the fan is placed on the outside. It is propelled by the wind passing through the hood and striking the outer blades. The revolving of the fan causes the suction.

In ventilating hospitals, stables and public buildings louvred ventilators are frequently employed. These may be either round, square or octagonal and similar to that shown in No. 32. These ventilators can be placed on either flat or pitched roofs and make an ornamental finish to the ridge or deck. When large ventilators of this style are used, the ventilating pipes leading to it are usually connected to a sheet metal drum under the ventilator, the drum being connected to the ventilator at the roof line. Sometimes an electric fan is placed inside of the ventilator to create suction. The forms of louvres usually employed are of the three styles shown in No. 33, the ventilation being secured as indicated by the arrows.

When round ventilators are connected to square or rectangular openings in flat roofs, a transition base, as shown in No. 37, is utilized. If a round

ventilator is connected directly to a double pitched roof, a separate joint is cut to fit over the pitched roof, as shown in No. 35, allowing a flange around the miter cut to solder to the metal roof or a small flange on to which a roof flange is soldered to form a flashing over a slate, tile or shingle roof.

When the base of the ventilator is square and is set over a double-pitched roof, the joint or connection can be made as shown in No. 36. The proper bevel of the roof is cut in the sides of the base and flanged out to receive the roof flange. The ventilator is then riveted over the collar.

CHAPTER XVIII.

CONSTRUCTION OF A LARGE VENTILATOR

The manner in which a large ventilator is constructed and fastened to a wooden curb is shown in detail in Fig. 215, in which a half elevation and a half-constructive view are given. In the half-sectional view A shows the wooden curb, over which the flashing is set, as shown by B. The inner body of the ventilator is made up in one piece, as shown by C D, over which E F, the outer body, is set, thus leaving an air space X between the two.

This air space is allowed to create a suction. Semi-circular openings are cut in the lower part of the outer body, as partly shown by a and b in the elevation, Fig. 215. As the wind circulates the air through these openings from a^1 to a^0 in the section, a suction is created which carries off the foul air from the inside indicated by the arrows G. H. J. K. and L, also indicated in the front by a' a' .

The cap or hood M is secured to the body of the ventilator E F before the outer body E F is soldered to the base N. On a large ventilator 16 braces are used, two on each side, the full brace being bolted, as shown from E to O, and the branch brace as shown from P to R. The 16 support braces shown from V to N are then bolted to the inner body, resting upon the curb as shown. When the ventilator is set on the curb, fastening straps are bolted at S and screwed to the curb at T and U.

180 *Constructing Large Ventilators*

When the curb is constructed of angle iron, as in fireproof structures, the base of the ventilator is

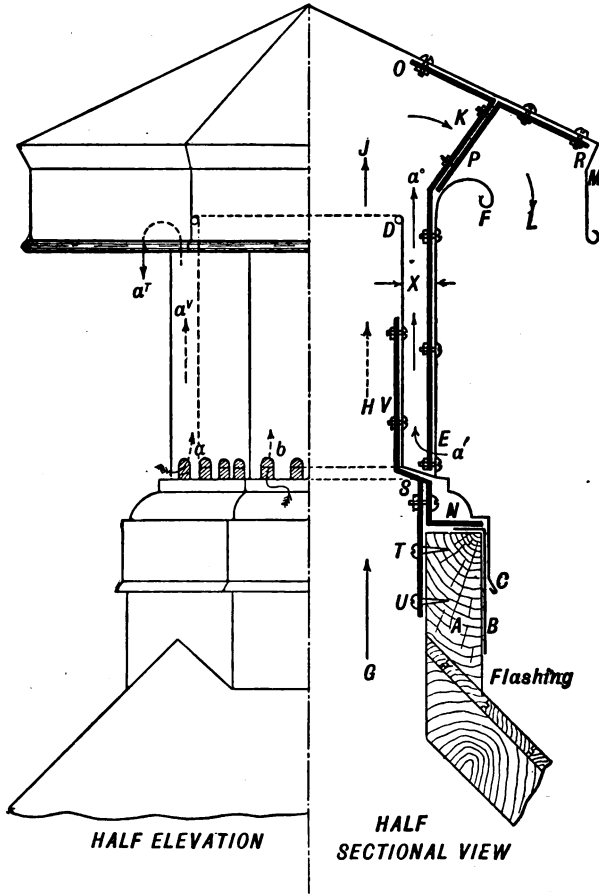

Fig. 215—Method of Constructing and Fastening Large Ventilator on Wooden Curb

secured, as shown in Fig. 216, where the brace of the ventilator is bolted at A to the angle iron curb B.

Constructing Large Ventilators 181

Where the bolts pass through the metal hood of the ventilator and through the wrought iron braces, the bolt heads are capped water tight, so as to avoid

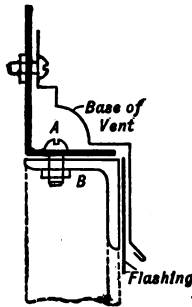

Fig. 216—Fastening the Ventilator to Angle Iron Curb

leakage. To make the caps use a one-inch hollow punch, and punch out of scrap metal a sufficient number of discs on a block of lead or wooden joist. By

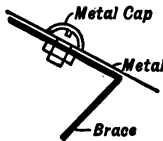

Fig. 217—Capping the Bolt Heads to Prevent Leakage

giving a heavy blow with the hammer when punching these discs, brings them to a concave shape, which should not be flattened. They are then soldered over the bolt heads, as shown in Fig. 217.

INDEX

Adjoining Elbows	77
Adjusting and Fastening Registers	113
Air Cleanser, Quadrupled	148
Air Cleanser, Single	147
Air Filters, Constructing	142
Air Tight Door in Drum, Constructing	126
Alloy and Links, Fusible	164
Angle Iron Butt Joint	62
Angle Iron Cross Joints, Reinforced	168
Angle Iron Frame for Casing Top	142
Angle Iron Frames	44
Angle Iron Slip, Construction of	60
Angle Iron Slip, Reinforced	61
Angle Iron Stiffeners	18
Angle Slip, Sheet Metal, Forming	59
Angles, and Brass Bands	17
Angles, Preparing Previous to Bending	44
Applying Punched S Slip	55
Area of Ducts	42
Area of Pipes and Ducts, Calculating	169
Area of Register, Finding the Effective	87
Areas and Circumferences of Circles, Table of	170
Areas, Computing	172
Asbestos Covering for Heat Ducts	105
Asbestos Paper	24
Asbestos Sheathing, Corrugated	25
Assembling Casings and Constructing Air Filters	142
Attaching Floor Register to Register Box	115
Band and Angle Iron	18
Band Iron Hangers	18
Bar Rest Used in Forging and Bending	13
Base for Round Ventilator	103
Baseboard Ventilating Plate, Convex	109
Bench, Movable	14
Bench, Stationary	14
Bending Corner Lock	141
Bending Cup Joint in Brake	47
Bending Double Locks	141
Bending Ducts	38
Bending Material	34
Bending Straight Sides of Elbow	84
Beveled Edge Slip	57
Beveled Wall Frames for Registers	106
Black and Galvanized Iron Rod	20

Blast Gates, Wind or	24
Bolts, Stove	21
Bracing, Diagonal	43
Bracing, Longitudinal and Horizontal	45
Bracing Material	34
Bracing Small Ducts	43
Bracing the Ducts	42
Branches, Curved, Connecting to Main Duct.....	128
Brass Bands and Angles	17
Brass Safety Chain	20
Brick Flues, Ventilating, Connecting	121
Burrs Used in Riveting	20
Butt Joint, Angle Iron.....	62
Calculating Area of Pipes and Ducts	169
Capping Bolt Heads of Ventilators to Prevent Leakage..	181
Casing for Entry of Air.....	135
Casings for Indirect Heating, Construction of.....	136
Casing, Galvanized Iron, In Indirect System of Heating..	27
Casings and Air Filters, Assembling and Constructing..	142
Casings for Indirect Radiation	133
Casing Top, Angle Iron Frame for.....	142
Casings with Single Walls	137
Casing with Air Space	142
Cast Iron Floor Boarder	111
Cast Iron Wall Box with Louvres and Netting	132
Ceiling Ducts, Hanging	63
Ceiling, False, for Supporting Runs of Ventilation Ducts	71
Ceiling Registers, Stamped	99
Ceiling Ventilators	98
Ceiling Ventilators, Register Boxes and Cleanouts.....	85
Chain for Louvre, Operation of	101
Check Valves in Cold Air Room	154
Circles, Areas and Circumferences, Table of.....	170
Circumferences and Areas of Circles, Table of.....	170
Cleanout and Register Box	91
Cleanout Door and Frame, Constructing	97
Cleanout Door, Construction of	92
Cleanout Frame with Non-Conducting Covering.....	105
Cleanout Slides and Doors	144
Cleanouts, Register Boxes and Ceiling Ventilators.....	85
Cleanders, Cold Air, Constructing	146
Clinching Register Collar	86
Cold Air Chambers, Lining	146
Cold Air Cleanders, Constructing	146
Cold Air Inlet, Louvre, Construction in	155
Cold Air Inlet, Placing Louvres in	153
Cold Air Room, Check Valves in	154
Cold Air Room with Metal Edged Flaps, Construction of	153
Collar for Register	86

Collars to Round Pipes, Connecting	123
Combination Screw Driver and Reamer	11
Connecting Brick Ventilating Flues	121
Connecting Collars to Round Pipes	123
Connecting Curved Branches to Main Duct	128
Connecting Heating and Ventilating Ducts	121
Connecting Rectangular or Square Ducts to Drum.....	126
Connection to Brick Flue, Sheet Metal	121
Constructing Air Tight Door in Drum	126
Constructing and Fastening Exposed Uptake.....	75
Constructing Large Elbows from Sections	83
Constructing Rectangular Elbows	125
Construction of a Large Ventilator.....	179
Construction of Damper	102
Construction of Flap	155
Construction of Mixing Dampers	150
Corner Joints, Vertical, Various Forms of	140
Corrugated Asbestos Sheathing	25
Covering Heat Ducts with Asbestos	105
Cross Joints	167
Cup Joint in Shaft Work, Longitudinal	47
Cup Joint, Longitudinal, Bending in Brake	47
Curb, Square, Placing in Roof	104
Curved Branches, Connecting to Main Duct	128
Cutting Material, Bending, Forming, Seaming, Grooving and bracing	34
Cutting Metal to Avoid Waste	35
Cutting Tapered Ends of Slip	54
Damper, Fusible	161
Damper, Construction of	102
Damper, Double Mixing, Construction of	156
Damper for Quick Warming	152
Damper, Operation of	104
Dampers	23
Dampers, Duct, Construction and Operation of	157
Dampers for Large Ducts, Making	160
Dampers, Mixing	150
Dampers, Mixing, for Quick Warming	152
Deflector, Heat, Placing on Register	116
Determining Size of Registers	89
Diagonal Bracing	43
Dimensions of Registers, Table of	89
Direct Indirect Heating System	27
Dolly, Round Faced	13
Dolly, Square Faced	13
Dolly, Uses of	54
Door in Drum, Constructing Air Tight	126
Double Edge Flat Slip, Forming	58
Double Elbow, Finding Unknown Size	78

Double Elbow, Laying Out	80
Double Locks, Bending	141
Double Seaming Large Elbows	82
Duct Connecting Flush with Top of Casing	145
Duct Dampers, Construction and Operation of	157
Duct for Bringing Outside Air, Construction of	132
Duct for Direct—Indirect Heating	129
Duct for Outside Vent, Construction of	163
Duct for Slip, Preparing End	53
Duct, Heavy Metal Heat, Hanging	70
Duct, Heavy Weight, Hanging with Wood Beam at Right Angles to Line of Duct	67
Duct, Metal, In Direct-Indirect Heating Systems.....	28
Duct Slips with Wired Edges	55
Duct with Corner Seams	47
Duct, Wall, with Metal Louvres	131
Ducts Against Walls, Securing Vertical Runs of	72
Ducts and Pipes, Calculating Areas of	169
Ducts, Area of	42
Ducts, Bending	38
Ducts, Ceiling, Hanging	63
Ducts for Acid Fumes, Exhaust	49
Ducts for Schools, Halls, Etc.	29
Ducts, Galvanized, In Forced Blast System of Heating..	29
Ducts, Grooving	39
Ducts, Heating and Ventilating, Connecting	121
Ducts, Heavy Weight, Hanging When Iron Beams Run at Right Angles	68
Ducts, Hoisting	63
Ducts in Attic, Supporting	71
Ducts, Large, Making Dampers for	160
Ducts, Large Size	45
Ducts, Light and Heavy Weight, Hanging to Iron Beams	68
Ducts, Light and Heavy Weight, Hanging to Wood Beams	66
Ducts, Light Weight, Hanging to Ceilings	65
Ducts, Shapes of	34
Ducts, Square and Rectangular	35
Ducts, Supporting and Fastening	63
Ducts, Triangular	35
Ducts with Outside Seam	46
Edge Slip, Re-enforced, Standing	58
Effective Area of Register, Finding	87
Elbow, Bending Straight Sides of	84
Elbow, Double, Laying Out	80
Elbow, Double, Finding Unknown Size	78
Elbow, Seaming	82
Elbows, Adjoining	77

Elbows, Constructing, Rectangular	125
Elbows, Joining Segments of	81
Elbows, Large, Constructing from Sections	83
Elbows, Large, Double Seaming of	82
Elbows, Large, Laying Out	79
Elbows, Laying Out and Constructing	77
Elbows, Large, Laying Out on the Floor	81
Elbows, Patterns for Segments of	82
Elbows, Large, Seaming and Riveting	83
Elbows, Large, Seaming without Riveting	84
Enclosing Radiator in Sheet Metal Casing	134
Exhaust Ducts for Acid Fumes	49
Exhaust Ducts in Attic, Supporting	72
Exhaust Ducts, Sheet Lead	17
Expansion Screw	21
Expansion Slip, Construction of	60
Expansion Slip Joints for Heavy Metal Ducts	61
Exposed Uptake, Constructing and Fastening	75
Exposed Uptake, Securing	74
Fastening Uptake in Flat Wall	73
Fastening Uptake in Recessed Wall	73
False Ceiling for Supporting Runs of Ventilation Ducts	71
Finishing Round Ceiling Ducts with Plaster	65
Finding Area of Pipe	169
Finding Girth of Inside Band of Stack	167
Finding Unknown Diameter with Aid of the Steel Square	171
Finding Unknown Size in Double Elbows	78
Flat Slip, Double Edge, Forming	58
Flanging Round Collars to Round Pipes	123
Flap, Construction of	155
Floor Border, Cast Iron	111
Floor Register, Fastening	114
Floor Registers, Setting	109
Flues and Ducts	46
Forming Material	34
Forming Stack	165
Forced Blast System of Heating	29
Forced Ventilation, Two Classes of	33
Frames, Angle Iron	44
Frame for Casing Top, Angle Iron	142
Fresh Air Ducts, How Made	28
Furring for Ducts	64
Fusible Alloy and Links	164
Fusible Damper, Construction	161
Fastening and Adjusting Registers	113
Fastening Ducts	63
Fastening Floor Register	114
Fastening Large Ventilator on Angle Iron Curb	181
Fastening Large Ventilator on Wooden Curb	180

Fastening Register Face to Angle Iron	114
Fastening Register Face to Sheet Metal Duct	115
Fastening Register Face to Wall Joist	113
Fastening Register to Metal Duct	114
Fastening Registers to Marble or Slate Side Walls.....	117
Fastening Riveted Slip	55
Gauge and Size of Sheet, Marking on Shelf	16
Gauges of Black Sheets, Etc.	9
Gauge of Iron for Ducts	34
Galvanized Iron Head in Register Box, Placing	98
Galvanized Iron Rod, Black and	20
Galvanized Sheet Iron	15
Galvanized Wire, Tinned or	20
Girth of Inside Band of Stack, Finding	167
Grooving Bar	13
Grooving Bar or Rail, Uses of	40
Grooving Ducts	39
Grooving Material	34
Hand Tools	7
Hanging Ceiling Ducts	63
Hanging Heavy Metal Heat Duct on Incline	70
Hanging Heavy Weight Ducts to Wood Beams	66
Hanging Heavy Weight Ducts when Iron Beams Run at Right Angles	68
Hanging Heavy Weight Duct when Iron Beams Run Parallel to Duct	69
Hanging Light and Heavy Weight Ducts to Iron Beams	68
Hanging Light Weight Ducts to Ceilings	65
Hanging Light Weight Duct When Iron Beams Run at Right Angles to Duct	69
Hanging Light Weight Duct When Iron Beams Run Parallel to Duct	68
Hanging LightWeight Duct When Wood Beams Run at Right Angles	66
Headers, Circular and Square, Constructing	85
Heat Deflector, Placing on a Register	116
Heat Deflectors, Use of	116
Heat Inlets	94
Heat or Vent Uptake in Fire Proof Construction, Setting	74
Heat Register	110
Heat Uptake	95
Heated Drum System of Ventilation	32
Heated Flue or Stack Ventilation System	31
Heating and Ventilating Ducts, Connecting	121
Heavy Metal Heat Duct, Hanging on an Incline	70
Heavy Weight Duct, Hanging with Wood Beams at Right Angles to Line of Duct	67
Hoisting Ducts	63

Holes, in Heavy Material, Punching	166
Indirect Heating, Casings for	136
Indirect Heating, Mixing Damper for	150
Indirect Radiation, Casings for	133
Indirect Radiator and Floor Register	136
Iron Beams Run Parallel to Duct	68
Iron for Ducts, Gauge of	34
Iron Rod, Black and Galvanized	20
Iron Rod Stiffeners	18
Joining Segments of Elbows	81
Joints, Angle Iron Cross, Re-enforced	168
Joints, Expansion Slip, for Heavy Metal Ducts	61
Joints for Stacks	165
Joints, Slip, Constructing	52
Joints, Standing, for Square Ducts	46
Joints, Vertical, Various Forms of	138
Killed Acid, Preparing	51
Large Ducts, Making Dampers for	160
Large Elbows, Double Seaming of	82
Large Elbows, Laying Out	79
Large Size Ducts	45
Large Ventilator, Construction of	179
Laying Out and Constructing Elbows	77
Laying Out Double Elbow	80
Laying Out Large Elbows	79
Laying Out Large Elbows on the Floor	81
Lead Cakes from Melted Scrap	13
Lead, Sheet	16
Light and Heavy Weight Ducts, Hanging to Iron Beams	68
Light Weight Duct, Hanging with Wood Beams at Right Angles	66
Limited Ventilation, Providing	102
Lining Cold Air Chambers	146
Lining Wall Flue	133
Location of Register with Water Level, Obtaining	118
Longitudinal and Horizontal Bracing	45
Longitudinal Cup Joint in Shaft Work	47
Longitudinal Seams, Various Styles of	36
Louvre Construction in Cold Air Inlet	155
Louvre Dampers, Operation of	161
Louvre Ventilators, Placing	99
Louvres in Cold Air Inlet, Placing	153
Louvres, Placing on Roof over Ceiling Register	101
Machine Screws, Wood and	22

Machinery Tools and Materials	7
Making Dampers for Large Ducts	160
Malleable Iron Damper for Smoke Pipe	23
Marking Gauge and Size of Sheet on Shelf	16
Marking Sheets	36
Marking Strip, Uses of	37
Materials and Stock for Heating, Ventialting and Exhaust Work	8
Material; Cutting, Bending, Forming, Etc.	34
Materials, Tools and Machinery	7
Mixing Damper, Double Construction of	156
Mixing Damper in Indirect Heating	150
Mixing Dampers for Quick Warming	152
Mixing Dampers, Construction of	150
Movable Bench	14
Movable Louvre, Formation of	155
Non-Conducting Covering	104
Non-Conducting Material, Table of Value of	105
Notching Corner of Double Damper to Prevent Binding	157
Natural System of Ventilation	30
Obtaining Location of Register with Water Level	118
Opening Bundles of Sheet Iron	15
Opening Cuts in Duct to Receive Register Box	97
Operation of Louvre Dampers	161
Operation of Shut-Off Valves	110
Pattern for Riveted Slip	55
Patterns for Segments of Elbows	82
Pipes and Ducts, Calculating Areas of	169
Pipes Offering Least Resistance to Flow of Air	35
Placing Registers in Ventilating Uptake	75
Planished Sheet Iron	14
Plenum System of Ventilation	33
Plumb Bob and Line	11
Preparing End of Duct for Slip	53
Prick Marking of the Sheets	36
Punched S Slip, Applying	55
Punching Holes in Heavy Material	166
Pulleys	23
Putting in Register Head	99
Raising Duct by Means of Rope	64
Rectangular Elbows, Constructing	125
Rectangular or Square Ducts, Connecting to Drum	126
Re-enforced Angle Iron Cross Joints	168
Re-enforced Angle Iron Slip	61
Ren-enforced Standing Edge Slip	58
Register Box and Cleanout in Heat or Vent Duct.....	96

Register Box, Cleanout and	91
Register Boxes, Carrying Flush with Plaster Line	98
Register Boxes, Cleanouts and Ceiling Ventilators	85
Register Box in Heat Uptake	86
Register Collar, Clinching	86
Register Collar, Preparing	86
Register Collars, Forming	86
Register Face, Fastening to Angle Iron.....	114
Register Face, Fastening to Wall Joist	113
Register Openings, Locating by Means of Water Level	119
Register Head, Putting in	99
Register to Metal Duct, Fastening	114
Registers, Fastening and Adjusting	113
Registers, Fastening, to Marble or Slate Side Walls....	117
Registers for Heat and Ventilating Ducts	106
Registers in Hot Air Inlets	109
Registers in Ventilating Uptake, Placing	75
Registers, Sizes of	88
Registers, Styles and Finish of	106-112
Registers, Table of Dimensions	89
Registers, Table of Standard Sizes of	91
Riveted Slip, Fastening	55
Riveted Slip, Pattern for	55
Rivets	20
Riveting Joints for Stacks	165
Riveting Large Elbows	83
Round Faced Dolly	13
Round Register with Cast Iron Floor Border	110
Round Ventilating Plate	109
Safety Chain, Brass	20
Screw, Expansion	21
Screws, Wood and Machine	22
Seaming a Double Large Elbow	82
Seaming Elbow	82
Seaming Large Elbows without Riveting	84
Seaming Material	34
Seams, Longitudinal, Various Styles of	36
Securing Exposed Uptake	74
Securing Uptakes in Fire Proof Construction	73
Securing Vertical Runs of Ducts Against Walls	72
Segments of Elbows, Joining	81
Segments of Elbows, Patterns for	82
Sheet Metal Angle Slip, Forming	59
Setting Heat or Vent Uptake in Fire Proof Construction	74
Shapes of Ducts	34
Sheet Lead	16
Sheet Lead Exhaust Duct	17
Sheet Metal Casing Enclosing Radiator	134
Sheet Metal Casings with Single Walls	137

Sheet Metal Connection to Brick Flue	121
Sheet Metal Dampers, How Formed	158
Sheet Metal Ventilating Systems	30
Sheet Metal Work in Heating and Ventilating Systems	26
Sheet Metal Work in Indirect Steam or Hot Water Heating System	27
Sheets, Storing	16
Shut-Off Valves, Operation of	110
Sizes and Gauges of Sheets	9
Sizes of Heat and Vent Ducts	34
Sizes of Registers, Standard, Table of	91
Slides and Doors, Cleanout	144
Slip, Angle Iron, Construction of	60
Slip, Beveled Edge	57
Slip, Expansion, Construction of	60
Slip Joints, Constructing	52
Slip Joints, Expansion, for Heavy Metal Ducts.....	61
Slip, Standing Edge	58
Smoke Pipe Damper	23
Soldering Sheet Lead, Precautions in	50
Soldering Sheet Lead to Galvanized Iron	50
Special Pointers on Equipment	9
Square Curb, Placing in Roof	104
Square Ducts, or Rectangular, Connecting to Drum.....	126
Square Faced Dolly	13
Stack, Forming	165
Stacks, Joints for	165
Stack Ventilation System, Heated Flue or.....	31
Stamped Zinc or Copper Ceiling Register	99
Standard Sizes of Registers, Table of	91
Standard Gauges and Sizes of Sheets	9
Standing Joints for Square Ducts	46
Stationary Bench	14
Stationary Louvre, Formation of	155
Stiffeners, Angle Iron	18
Stiffeners, Iron Rod	18
Steel Wire Nails	22
Stove Bolts	21
Storing Sheets	16
Stubbs Wire Gauge	19
Supporting and Fastening Ducts	63
Supporting Ducts in Attic.....	71
Table of Circumferences and Areas of Circles.....	170
Table of U. S. Standard Gauge for Uncoated Sheets and Plates	10
Tapered Ends of Slip, Cutting	54
Telescope Sheet Metal Tool Chest	12
Through Register Box	94
Tinned or Galvanized Wire	20

Tool Chest, Sheet Metal Telescope	12
Tools, Machinery and Materials	7
Transportation of Ducts	39
Turn Buckles	24
Uptake, Exposed, Constructing and Fastening.....	75
Uptake, Exposed, Securing	74
Uptake, Heat	95
Uptake, Heat or Vent, in Fire Proof Construction, Setting	74
Uptake in Flat Wall, Fastening	73
Uptake in Recessed Wall, Fastening	73
Uptake, Vent	95
Uptake, Ventilating, Placing Registers in	75
Uptakes in Fire Proof Construction, Securing.....	73
Vacuum or Exhaust System of Ventilation	33
Various Forms of Vertical Joints	138
Various Types of Ventilators	174
Vent Duct, Outside	164
Vent Ducts, Sizes of Heat and	34
Vent Outlets, Placing	94
Vent Uptake	95
Vent Uptake in Fire Proof Construction, Setting	74
Ventilation, Heated Drum System of	32
Ventilation, Natural System of	30
Ventilation, Plenum System of	33
Ventilation, Providing Limited	102
Ventilation System, Heated Flue or Stack	31
Ventilation, Vacuum or Exhaust System of	33
Ventilating Ducts, Connecting Heating and	121
Ventilating Plate, Convex Baseboard	109
Ventilating Plate, Round	109
Ventilating Systems, Sheet Metal	30
Ventilating Uptake, Placing Registers in	75
Ventilators and Register Faces	107
Ventilators, Ceiling	98
Ventilator, Large, Construction of	179
Ventilator, Round Base for	103
Ventilators, Various Types of	174
Vertical Corner Joints	140
Vertical Joints, Various Forms of	138
Vertical Runs of Ducts Against Walls, Securing	72
Wall Box with Louvres and Netting, Cast Iron.....	132
Wall Duct for Direct-Indirect Heating, Constructing ..	129
Wall Duct with Metal Louvres	131
Wall Flue, Lining	133
Wall Frames, Beveled	106
Wall Hooks	22

Warm Air Furnace Work, Sheet Metal in	26
Warm Air Pipes and Registers	27
Washer Used with Bolts	21
Wire Grills or Register Faces	107
Wire Nails, Steel	22
Wind or Blast Gates	24
Wood and Machine Screws	22

