

**“STANDARD”**  
**✂Work on Cutting.✂**

---

**THIRD EDITION.**

**TT**  
590  
M67

LIBRARY OF CONGRESS.

Chap. .... Copyright No. ....

Shelf TT590

A67

UNITED STATES OF AMERICA.

APR 3 1884





# "STANDARD" WORK ON CUTTING.

*Revised, Enlarged and Improved.*

---

THIRD EDITION.

---

15.9  
4418

A COMPLETE TREATISE

ON THE

ART *AND* SCIENCE OF GARMENT CUTTING.

---

PUBLISHED BY  
**THE JNO. J. MITCHELL CO.,**  
NEW YORK.  
1884.

TT 590  
.M 67

1441673\*

---

Entered according to Act of Congress, in the year 1884, by

THE JNO. J. MITCHELL CO.

In the office of the Librarian of Congress, at Washington.

---

9-13601

# I N D E X .

---

	PAGE.
PART 1.	
Preface .....	5
Measurement of the Form .....	6
Measurement Systems (Coats and Vests) .....	10
"        "    (Capes and Cloaks) .....	36
"        "    (Pantaloons) .....	41
PART 2.	
"Standard" Scale .....	47
Key to "Standard" Scale and Table of Proportion .....	49
Proportionate Systems (By "Standard" Scale) .....	50
PART 3.	
Misfits .....	67
Inclination or Attitude .....	68
PART 4.	
Use of Block Patterns .....	73
PART 5.	
Making up .....	84
PART 6.	
Creases in General .....	90





---

---

## PREFACE TO THE THIRD EDITION.

---

THE "Standard" System, has been so long before the Trade and so fully recognized, that we feel there is no need to enter into any defence of its principles, but simply to thank our manifold patrons for the support that has made it popular.

This, the 3d Edition, is much enlarged and simplified, and the revision is so thorough, as to make it to all intents and purposes a new Work.

It is put forward not as an Anatomical nor Geometrical Treatise, but *as a practical method*; the student of its pages is directed to be careful in his measurements and strict in the application of the instructions laid down. Discarding disputation we enjoin attention to detail and a careful study of the peculiarities of the living form. While abiding by the principle embodied in the 1st and 2d Editions, we have modified the method of its application to the requirements of the present time, and in so doing, have arranged for an easy and graceful garment; one moreover, that will keep in good form and not wear into unsightly creases.

This is the test of first-class cutting as well as of first-class manufacture; and no garment will answer to it, except it be so balanced, that it will fall naturally to the lines of the figure, giving, at the right place, sufficient room for unimpeded motion of the muscles.

We have thought it advisable to treat "Misfits" systematically, as will be seen on consulting that article; we would call especial attention to the Diagrams and Explanations Illustrative of the "Attitude or Inclination" of the Figure: this is a consideration quite distinct from length and size, and is too frequently overlooked; it is within the memory of the present generation that this question was opened up; and it is now customary only by the advanced Cutter, to follow more or less the lines of the form in its extreme variations; but, owing to crude theories of balance, generally accepted by the craft, he stops with the shoulders; the attitude of the body below the waist is supposed to be provided for, by more or less cloth on the back plait; the consequence is that it is either *lap* or *yape*; the "stooping figure" overlaps the back skirts, and is troubled at the hip buttons; the reverse order of failure takes place with the "over erect," and the back skirts *yape*; both errors attributable to the difference of inclination in the back skirt and the part it covers.

"The use of Block Patterns" is fully illustrated, giving all the necessary variations for difference of position and measurement. The articles on "Making up" and "Creases in general" are thoroughly practical and cover a large area of trouble incident to the Cutting profession.

This Work is mainly intended for the Student and therefore covers very elementary ground, nevertheless, we feel assured that the most experienced Cutter will be repaid by its careful study.

Respectfully,

THE JNO. J. MITCHELL CO.

## MEASUREMENT OF THE FORM.

**I**NCORRECT Measurement, arises mainly from haste or carelessness, and is a fruitful source of trouble to the Cutter; the best draft must be a failure if founded on measures not truly taken.

The measures on which the "Standard" System is based are few and simple, but they require to be taken with care.

Measuring Jackets are growing into favor with the Trade; they should be made up firmly, padded and wadded as usually worn, with both sleeves put in. One sleeve causes mistakes by allowing the Jacket so easily to get out of place, and, as most customers have a difference in the lengths of their arms, two sleeves make the detection easy to the Cutter, without annoyance to the Customer.

A set of Jackets 34, 36, 38, 40 and 42, cut straight in front and large enough to pin together easily is all that is required. A Set, carefully cut by our new Scale, having the lines by which the draft is produced sewed through by machine in colored silk so as to be plainly marked, cannot fail to give the Cutter many a valuable suggestion that can be noted in the measure book.

Illustrative Figs. 1 and 2, represent one method of taking the measures, the draft being based upon the location of the two points: one at the front of the scye, taken on a level under the arm, and the other taken from a point on the back seam, also on a level under the arm; it will be seen at once, that these two points should be carefully located to start with; this is a very simple method, requiring only a small square and a piece of rough cardboard or leather, with inches marked on either side. Close the Coat, place the straight edge of the cardboard as close under the arm as is convenient, taking especial care that it is close. Mark on the top edge, front and back of scye, hold in same position and place square as seen on Fig. 2; locate points front and back as denoted by the square; the numbers on the cardboard are only useful, as marking more accurately the location of the arm of the square.

Remove the straight edge, and measure from socket bone at O, to C on back seam— $8\frac{3}{4}$ , to natural waist— $16\frac{1}{2}$ , to fashionable waist— $18\frac{1}{2}$ , full length—30; the point located at back scye will give the width of back— $7\frac{1}{4}$ , to elbow—20, full length of sleeve—31; from point located at front of scye under the arm to C— $11\frac{1}{2}$ , from same point at front of scye up in front of shoulder to socket bone, (1st over measure)— $12\frac{1}{4}$ ; from same point at front of scye across front shoulder down to C, (2d over measure)—18; Breast measure on the Vest, on the blade neither above nor below—36, waist—32, on the hips below the waist—35; measures:

$8\frac{3}{4}$	$7\frac{1}{4}$	$11\frac{1}{2}$	}	36
$16\frac{1}{2}$	20	$12\frac{1}{4}$		32
$18\frac{1}{4}$	31	18		35
30				

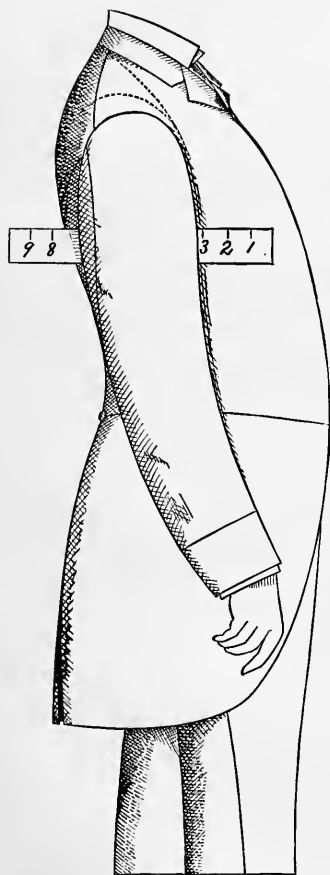

Fig. 1

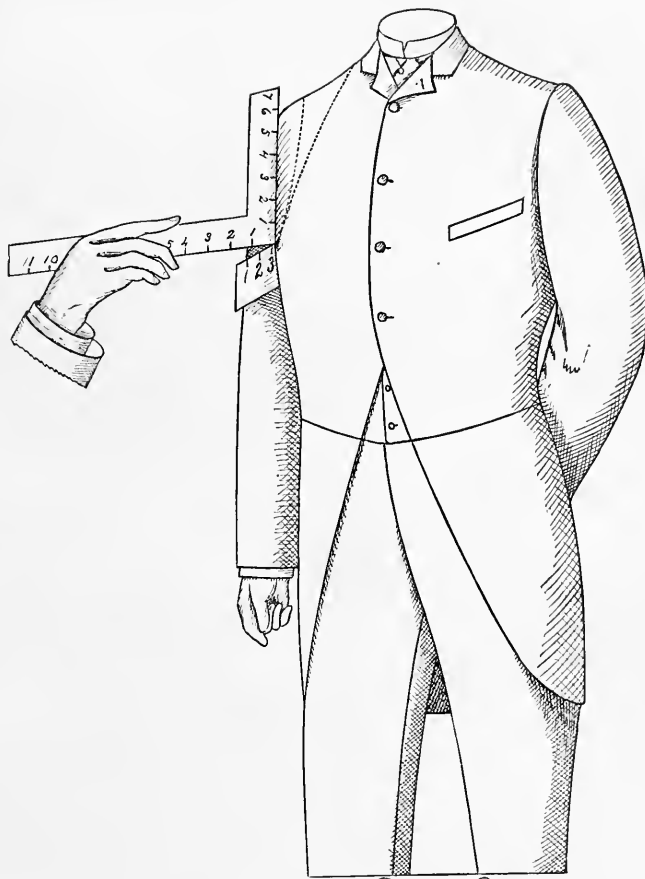

Fig. 2.

MEASUREMENT, *Continued.*

Another Method, and perhaps the most popular with the Trade, is represented on Figs. 3 and 4.

After having closed the Coat, the ordinary square with sliding arm is placed against the back, one arm being placed close to the left side of the form and as close as possible up under the arm without disturbing the shoulder; close in the sliding arm to the right side of the figure. Mark across at front of scye and on back seam and before removing square, lay a short square on the sliding arm resting against front of scye, but not too close, as the scye must give room for motion of the arms and the play of muscles; do the same at back scye for width of back, remove square, and measure from points as now located.

The advantage of the lines on the Measuring Jacket will be apparent at once the mark made for depth of scye on back, can be compared with the normal line of the method and so at the front of scye, and the judgment of the Cutter is called upon, to consider and alter if necessary the measures taken; thus a false step at the starting point can be at once adjusted, saving the expense of bushelling and the consequent annoyance to Employer, Customer and Cutter.

The measure from the front of scye to the natural waist has been omitted in this Edition, the draft being balanced by the square of the breast measure which is a far better guide than a measure which passes over a curvilinear surface, at one part rounded, and at another hollow. It has been usual to instruct the Student to take this measure tight, but it is not a reliable measure as is proved by taking it always exact, and then finding in practice that no regular reduction will insure correctness; there are many methods of waist suppression superior to it, and we have found the one given satisfactory. The Student must not suppose that his measures are incorrect, simply because they sometimes happen to be much longer or shorter than he may have hitherto met with; on a 36 Breast the front scye measure to the center of back at scye level, will vary from  $11\frac{1}{2}$  to  $12\frac{3}{4}$  inches; the measure from front of scye over shoulder to socketbone, will vary on a 36 Breast, from  $11\frac{1}{2}$  to  $12\frac{1}{2}$ , and in very extreme cases even to 13 inches.



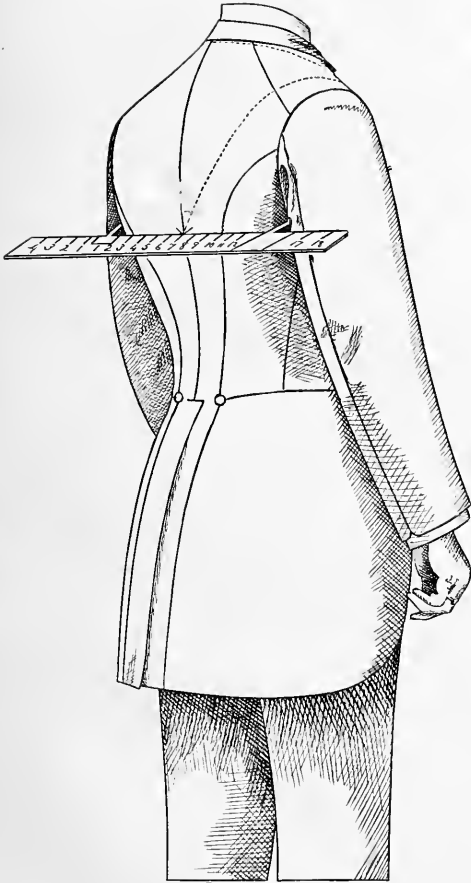

Fig. 4.

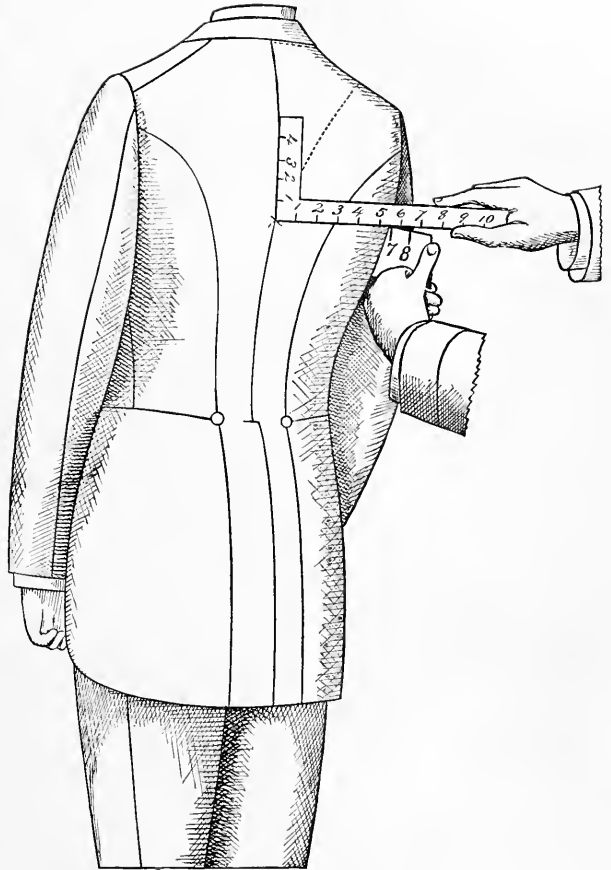

Fig. 3.

## DIAGRAM 1. S. B. SACK.

MEASURES.	$\left. \begin{array}{l} 8\frac{3}{4} \\ 16\frac{1}{2} \\ 18\frac{3}{4} \\ 30 \end{array} \right\} \text{Lengths.}$	Front of Scye, $11\frac{1}{2}$	$\left\{ \begin{array}{l} \text{Sleeve} \quad 7\frac{1}{2} \\ 20 \\ 31 \end{array} \right.$
		First over measure, $12\frac{1}{4}$	
		Second over measure, 18	

Breast, 36; Waist, 32; Hip, 35.

## DRAFT PRODUCED BY THE MEASURES.

ARRANGE measures by which to draft as follows:

Add  $\frac{3}{4}$  to depth of scye,  $8\frac{3}{4}$ — $9\frac{1}{2}$  inches;  
 Add 1 to front of scye,  $11\frac{1}{2}$ — $12\frac{1}{2}$  inches;  
 Add  $\frac{3}{4}$  to front of scye to square the shoulder by,  $11\frac{1}{2}$ — $12\frac{1}{4}$  inches;  
 Add  $\frac{1}{2}$  to first over measure,  $12\frac{1}{4}$ — $12\frac{3}{4}$  inches;  
 Deduct  $\frac{1}{4}$  from second over measure, 18— $17\frac{3}{4}$  inches.  
 Draw line for back seam and square across as at O;  
 From O to C is  $9\frac{1}{2}$  inches—From O to natural waist is  $16\frac{1}{2}$  inches—From O to fashionable waist is  $18\frac{1}{2}$  inches—From O to full length is 30 inches—Rise of neck,  $\frac{5}{8}$  of an inch;

Width of top of back is  $2\frac{3}{4}$  inches;

B is half way between O and C; A is  $1\frac{1}{8}$  inch above B;

A to W is  $7\frac{1}{4}$  inches—square down to breast line—top of side seam is at  $\frac{1}{8}$  from line C; Form side seams taking out at natural waist  $1\frac{1}{4}$  inch—spring is  $\frac{1}{12}$  at 30 inches from O, for all lengths and sizes;

From C to F is  $12\frac{1}{2}$  inches; Square up as illustrated;

From C mark off  $\frac{1}{2}$  breast, 18, and add  $2\frac{1}{4}$  inches; Square down—add 1 inch for button step; From C sweep up for front of breast; At B, lay  $12\frac{1}{4}$  inches on square, the angle falling on breast line at E—and square up by the other arm; From F, sweep across this line by first over measure, deducting width of top of back for shoulder point;

Hollow back as illustrated and cut it out; Lay back in position at shoulder point, and form shoulder seam by second over measure  $17\frac{3}{4}$ , dropping at scye point  $\frac{1}{2}$  inch;

Form scye—shape gorge, raising neck at front 1 inch, taking out small V;

Sweep front length from shoulder point, by length of side seam;

Notch at back scye is from W;

Finish draft as illustrated.

(Continued on page 12.)

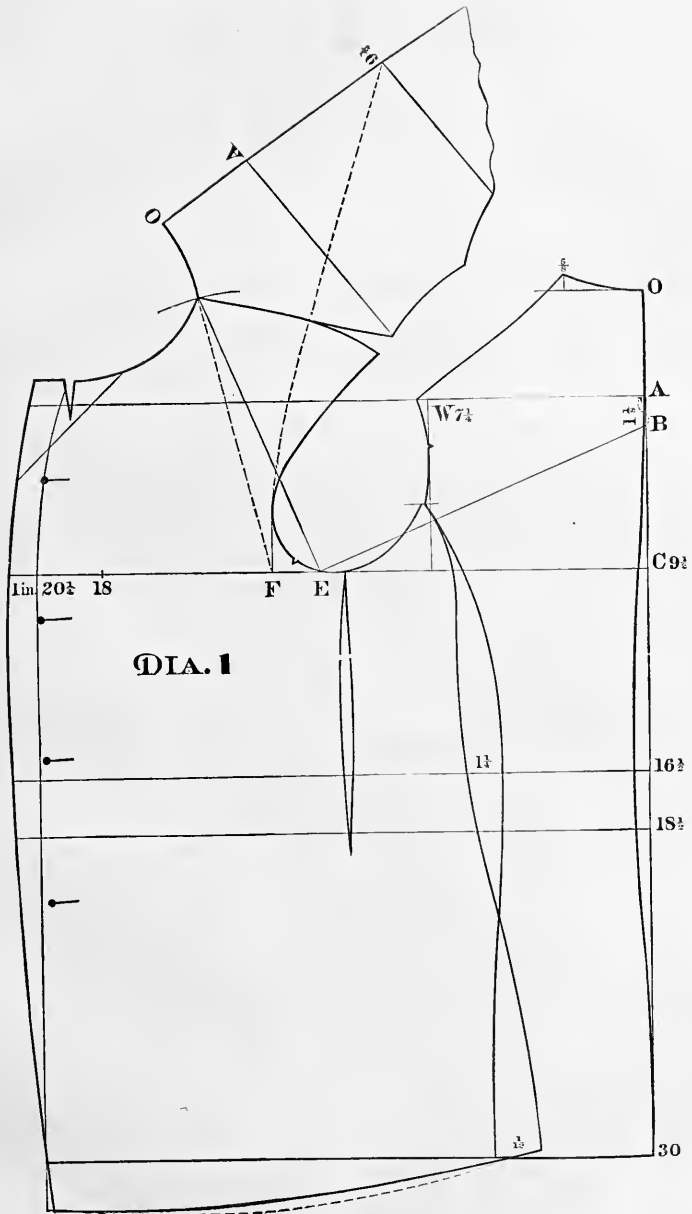

S. B. SACK, *Continued.*

REMARKS.—The depth of scye measure on back seam, taken by a level under the arm is nearly always taken short; if taken strictly correct it cannot be applied literally, as taken, without giving too short a length of back stretch; it is necessary to add  $\frac{1}{2}$  inch in the application of this measure, and by adding  $\frac{1}{4}$  more for seam we get the  $\frac{3}{4}$  which we advise in the use of this measure; those who neglect this precaution get their coats too short in the back. In shaping the gorge take care that it is not too hollow; it is a misconception to suppose that it is necessary to make what is called a true curve from O, through the shoulder point to the button step; the height of front neck and depth of stand of collar, govern the line of the neck curve and any other idea is a fallacy accepted without sufficient thought; style controls both points—if the collar is narrow, the back at top of back seam must be higher; if the roll is short, the front neck must be higher also; high or low at back, or front the side of the neck is a point not much affected thereby, and the consequence is, that the sweep of the neck curve has to meet either contingency.



## DIAGRAM 2. LONG SOFT ROLL SACK.

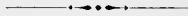

DRAFTED same as Diagram 1 on page 11, except that it is cut more or less full on the lappel edge, according to the prevailing style; the dotted lines represent the neck and gorge as usually cut; the solid lines the necessary deviations to secure a close fitting Coat at the side of the neck, and yet preserve the desired effect of the long narrow roll. The collar does not require to be cut more crooked than in the diagram.



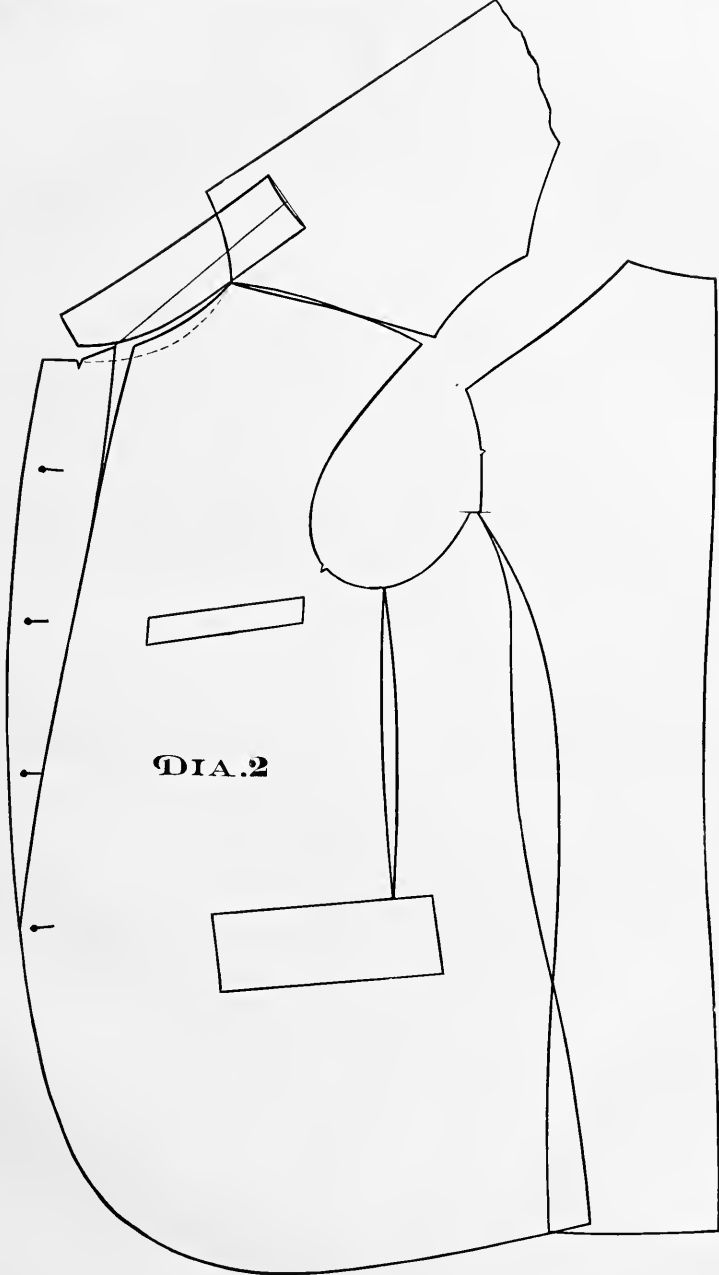

## DIAGRAM 3. S. B. OVER-SACK.

MEASURES	$8\frac{3}{4}$ $17\frac{1}{2}$ 19 38	Lengths.	}	Front of Scye, $11\frac{1}{2}$ First over-measure, $12\frac{1}{4}$ Second " 18 Breast, 38 (over the coat), Seat, 39	}	Sleeve.	$7\frac{3}{4}$ 20 32
----------	---	----------	---	--	---	---------	----------------------------

### DRAFT PRODUCED BY THE MEASURES.

- A** RRANGE measures by which to draft, as follows :
- Add 1 to depth of scye,  $8\frac{3}{4}-9\frac{3}{4}$  inches.
  - Add  $1\frac{1}{2}$  to front of scye,  $11\frac{1}{2}-13$  inches.
  - Add  $1\frac{1}{2}$  to front of scye to square shoulder by,  $11\frac{1}{2}-13$  inches.
  - Add 1 to first over-measure,  $12\frac{1}{4}-13\frac{1}{4}$  inches.
  - Add  $\frac{1}{2}$  to second over-measure,  $18-18\frac{1}{2}$  inches.
  - Draw line for back seam ; square across as at O.
  - From O to D is  $2\frac{2}{3}$  inches.
  - Form top of back, raising at O  $\frac{1}{4}$  and at D 1 inch.
  - From O to C is  $9\frac{3}{4}$ ; natural waist  $17\frac{1}{2}$ ; fashionable waist 19; full length 38 inches.
  - B is half way between O and C.
  - A is  $1\frac{1}{5}$  inch above B; A to W is  $7\frac{3}{4}$  inches ; square down to breast line.
  - Top of side seams is  $\frac{1}{2}$  above breast line (19 on 12ths).
  - Form side seams taking out at natural waist  $1\frac{1}{2}$  inch.
  - Spring is  $\frac{1}{6}$  at line 36 inches down.
  - From C to F is 13 inches ; square up 3 inches.
  - Measure across breast 19, adding  $\frac{3}{4}$  for reductions at back seam and blade.
  - Add  $2\frac{1}{2}$  for making up and square down.
  - Make step 2 inches more or less and square down.
  - Sweep up for front from C.
  - On line 36 reduce at front  $1\frac{1}{4}$  inch.
  - Form front as illustrated.
  - At B lay arm of square at 13 inches, letting the angle of square fall on the breast line at E, and square up by the other arm.
  - From F sweep across this line by first over-measure  $13\frac{1}{4}$ .
  - Take off width of top of back  $2\frac{2}{3}$  inches.
  - Hollow back seam, springing it out at bottom on line 36, one inch.
  - Cut out back and place same in position at shoulder point.
  - Close the shoulder by 2d over-measure.
  - Reduce at point of scye scant  $\frac{1}{2}$  inch, and form arm scye as illustrated.
  - Back pitch is  $\frac{1}{2}$  way between A and C.
  - Form gorge of neck, raising at front 1 inch.
  - Take out V as illustrated.
  - Make the neck curve to follow diagram.
  - Avoid a curve like the dotted line.
  - Sweep for bottom from shoulder point by length of side seam.
  - Take out fish under arm and finish draft as illustrated.

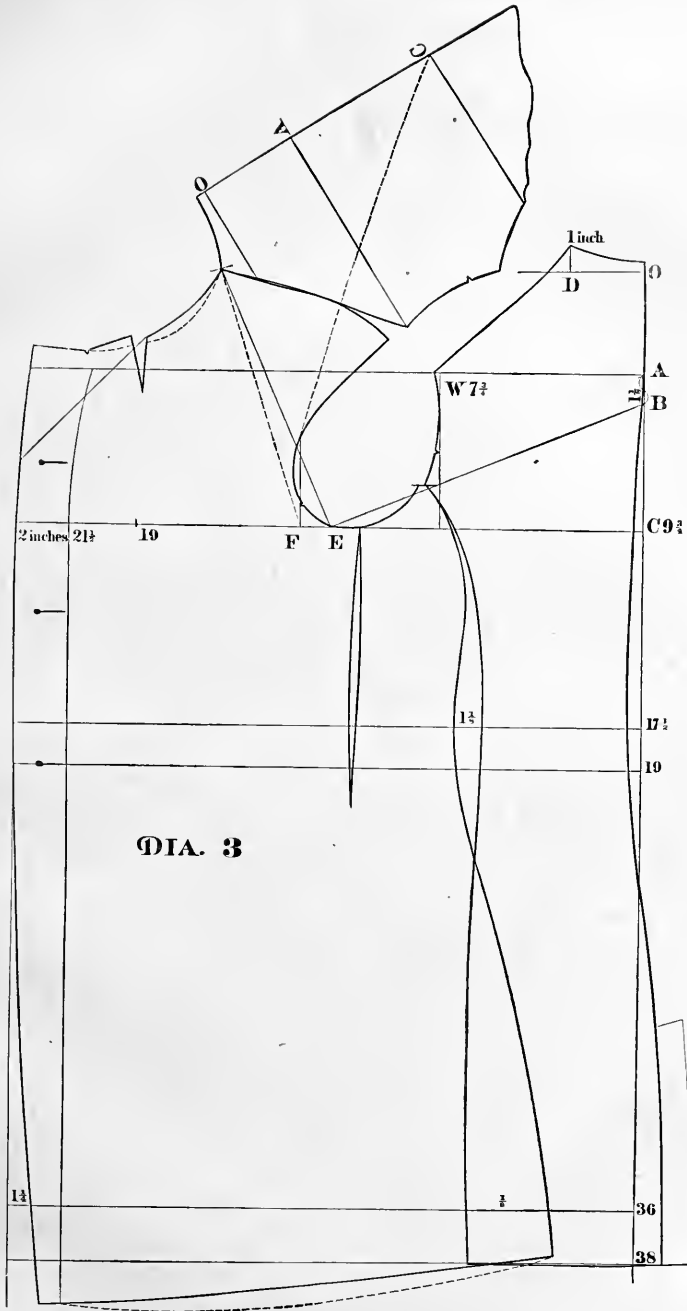

## DIAGRAM 4. S. B. ONE BUTTON CUTAWAY.

MEASURES.	$\left. \begin{array}{l} 8\frac{3}{4} \\ 16\frac{1}{2} \\ 18\frac{1}{2} \\ 33 \end{array} \right\} \text{Lengths.}$	$\left. \begin{array}{l} \text{Front of scye } 11\frac{1}{2} \\ \text{First over measure } 12\frac{1}{4} \\ \text{Second over measure } 18 \\ \text{Slope of shoulder } 20, 25\frac{1}{4} \\ \text{Breast } 36, \text{ Waist } 32, \text{ Hip } 35. \end{array} \right\}$	$\left. \begin{array}{l} \text{Sleeve. } 7\frac{1}{2} \\ 20 \\ 31 \end{array} \right\}$
-----------	---	---	---

## DRAFT PRODUCED BY THE MEASURES.

**A** RRANGE measures by which to draft as follows :

Add  $\frac{3}{4}$  to depth of scye,  $8\frac{3}{4}-9\frac{1}{2}$  inches.

Add 1 to front of scye,  $11\frac{1}{2}-12\frac{1}{2}$  inches.

Add  $\frac{3}{4}$  to front of scye to square shoulder by  $11\frac{1}{2}-12\frac{1}{4}$  inches.

Add  $\frac{1}{2}$  to first over measure,  $12\frac{1}{4}-12\frac{3}{4}$  inches.

Deduct  $\frac{1}{4}$  from second over measure,  $18-17\frac{3}{4}$  inches.

Draw line for back seam, and square across as at O;

From O to D is  $2\frac{3}{4}$  inches; square up  $\frac{3}{8}$  for rise of neck; form top of back.

From O to C is  $9\frac{1}{2}$  inches; from O to natural waist is 16, the fashionable waist  $18\frac{1}{2}$ , full length 33 inches. B is half way between O and C; A is  $1\frac{1}{2}$  inch above B;

A to W is  $7\frac{1}{4}$  inches ; square down to breast line ; top of side seam is  $2\frac{1}{4}$  inches from W (18 on Sths.) Form side seams to fancy; at top of side seams reduce a trifle, but keep the top of side seam on a level with short line as illustrated; on line C, take out  $\frac{1}{4}$  inch; at natural waist  $1\frac{3}{4}$  inch ;

From C to F front of scye is  $12\frac{1}{2}$  inches; square up as illustrated.

From C mark off  $\frac{1}{4}$  breast 18, allowing  $\frac{3}{8}$  for reductions at back seam and blade; add  $2\frac{1}{4}$  and square down; add 1 inch for button step and sweep up from C for front; Form front more or less cutaway as desired;

At B lay  $12\frac{1}{4}$  inches on square the angle resting on breast line at E and square up by the other arm; From F sweep across this line by first over measure deducting width of top of back for shoulder point;

Hollow back as illustrated and cut out ; Place back in position at shoulder point and form shoulder by second over measure  $17\frac{3}{4}$ , dropping point of scye  $\frac{1}{2}$  inch;

Form scye as illustrated ; form under arm seams, reducing  $\frac{1}{2}$  inch at natural waist; form gorge, raising front of neck 1 inch above line A; Reduce at step by small V;

Sweep for length of front, at 1 inch behind shoulder point by length of side seam. Before cutting out the scye, place back and side body in closing position, and correct shape of scye if necessary; Back pitch is  $\frac{1}{16}$  from W;

Remarks:—In this Draft a new measure is introduced for closing the slope of shoulder, familiar to many, though not generally known; the measure is taken on the body, placing say 20 on the tape measure at the socketbone or collar seam, (either on Coat or Vest); throw the end of tape which commences at 1 over the front of shoulder bringing it close up under the arm and up round the back scye; take hold of the end of the measure at 1 by the right hand, and holding it firmly at back scye let go the measure at 20, and bring it down to the level of arm scye on back seam; call off the measure,  $25\frac{1}{4}$  in the present case; this shows a difference of  $5\frac{1}{4}$  inches in the two over measures; this measure is applied on the draft exactly as it is taken on the body; place back in closing position at shoulder; place 20 at O and carry the end of the measure that commences at 1 close to the front of scye; place the finger of the left hand on it where it touches the front of scye, and then let go the measure at O and bring it down to C, and if it measures  $\frac{1}{4}$  inch less than  $25\frac{1}{4}$  the shoulder is closed correctly; if more or less, close or open it to 25.

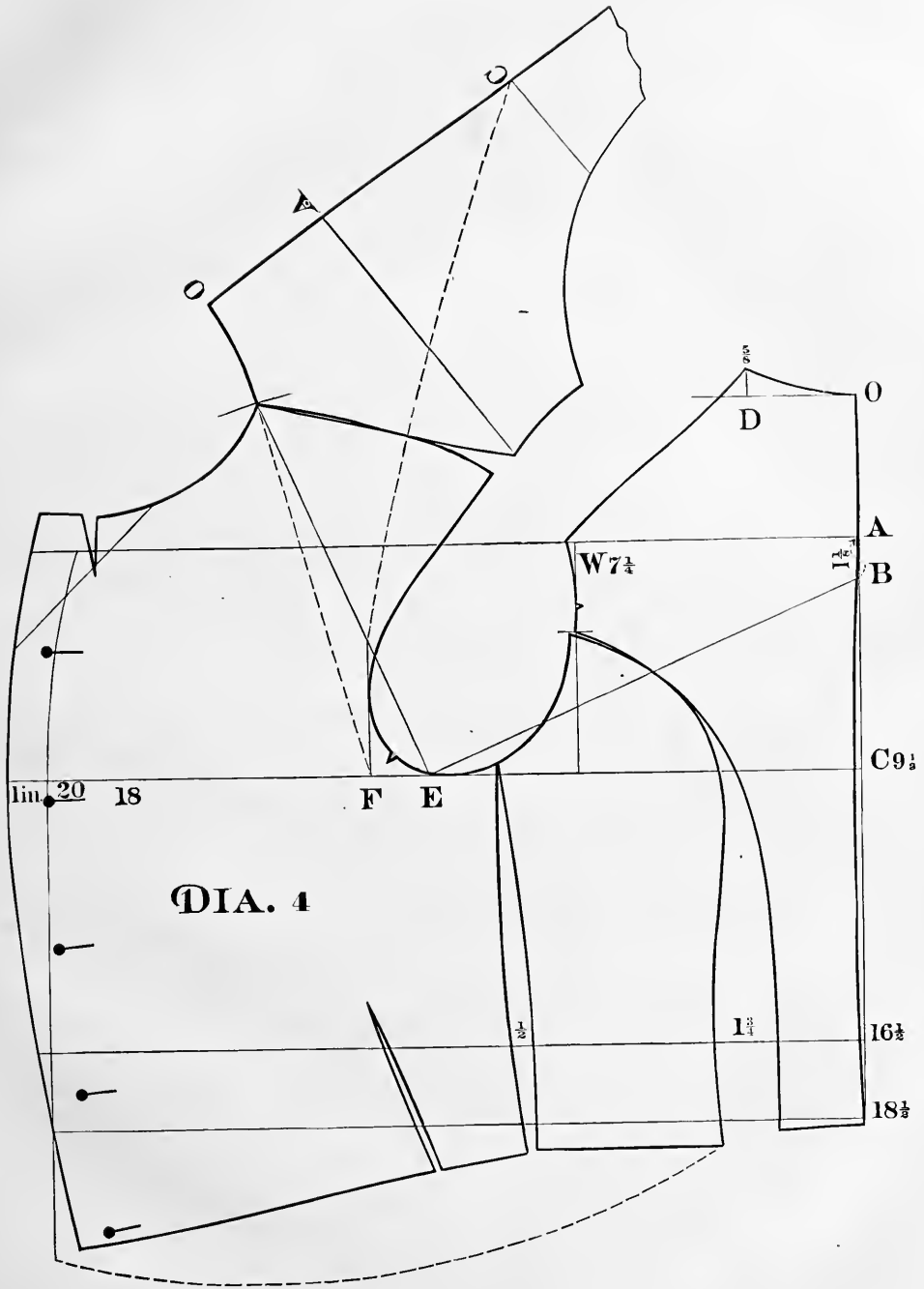

## DIAGRAM 5. S. B. FOUR-BUTTON CUTAWAY.

MEASURES.	$8\frac{3}{4}$ $16\frac{1}{2}$ $18\frac{1}{2}$ $33$	Lengths. } Front of scye, $11\frac{1}{2}$ First over-measure, $12\frac{1}{4}$ Second over-measure, 18 Breast, 36; Waist, 32; Hip, 35	{ Sleeves. $7\frac{1}{2}$ 20 31
-----------	--	--	--

### DRAFT PRODUCED BY THE MEASURES.

**A**RRANGE measures by which to draft as follows :

Add  $\frac{3}{4}$  to depth of scye  $8\frac{3}{4}$ - $9\frac{1}{2}$  inches.

Add 1 to front of scye  $11\frac{1}{2}$ - $12\frac{1}{2}$  inches.

Add  $\frac{3}{4}$  to front of scye to square shoulder by  $11\frac{1}{2}$ - $12\frac{1}{2}$  inches.

Deduct  $\frac{1}{4}$  from second over-measure  $18$ - $17\frac{3}{4}$  inches.

Draw line for back seam and square across as at O.

From O to D is  $2\frac{3}{4}$  inches; square up  $\frac{5}{8}$  for rise of neck; form top of back.

From O to C is  $9\frac{1}{2}$  inches : to natural waist is 16 ; fashionable waist  $18\frac{1}{2}$  ; full length 33 inches. B is half way between O and C ; A is  $1\frac{1}{8}$  inch above B.

A to W is  $7\frac{1}{4}$  inches ; square down to breast line ; top of side seam is  $2\frac{1}{4}$  inches from W (18 on 8ths).

Form side seams to fancy ; at top of side seams reduce a trifle, but keep the top of side seam on a level with short line, as illustrated ; on line C, take out  $\frac{1}{2}$  inch and at natural waist,  $1\frac{3}{4}$  inch.

From C to F front of scye is  $12\frac{1}{2}$  inches ; square up as illustrated.

From C, mark off  $\frac{1}{2}$  breast 18, allowing  $\frac{3}{4}$  for reductions at back seam and blade; add  $2\frac{1}{4}$  and square down; add 1 inch for button step, and sweep up for front.

At B, lay  $12\frac{1}{4}$  inches on square, the angle resting at E, and square up by the other arm. From F sweep across this line by first over-measure, deducting width of top of back, for shoulder point. Hollow back as illustrated, and cut it out.

Place back in position at shoulder point, and form shoulder by second over-measure,  $17\frac{3}{4}$ ; dropping point of scye  $\frac{1}{2}$  inch.

Form scye as illustrated; form under arm seams, reducing  $\frac{1}{2}$  inch at natural waist. Form gorge, raising front of neck 1 inch above line A.

Reduce at step by a small V.

Sweep for length of front, at 1 inch behind shoulder point by length of side seam. Cut side body through under arm.

Before cutting out the scye place back and side body in closing position, and correct shape of scye if necessary; back pitch is  $\frac{1}{4}\frac{1}{2}$  from W.

Measure across the closed draft on the waist line, allowing for seams,  $\frac{1}{2}$  the size of hip, and make a mark; add 1 inch over and draw line of front through this point; space off buttons; top button is  $3\frac{1}{4}$  inches from top of step; place skirt in closing position at front of waist and form front from bottom button, as illustrated.

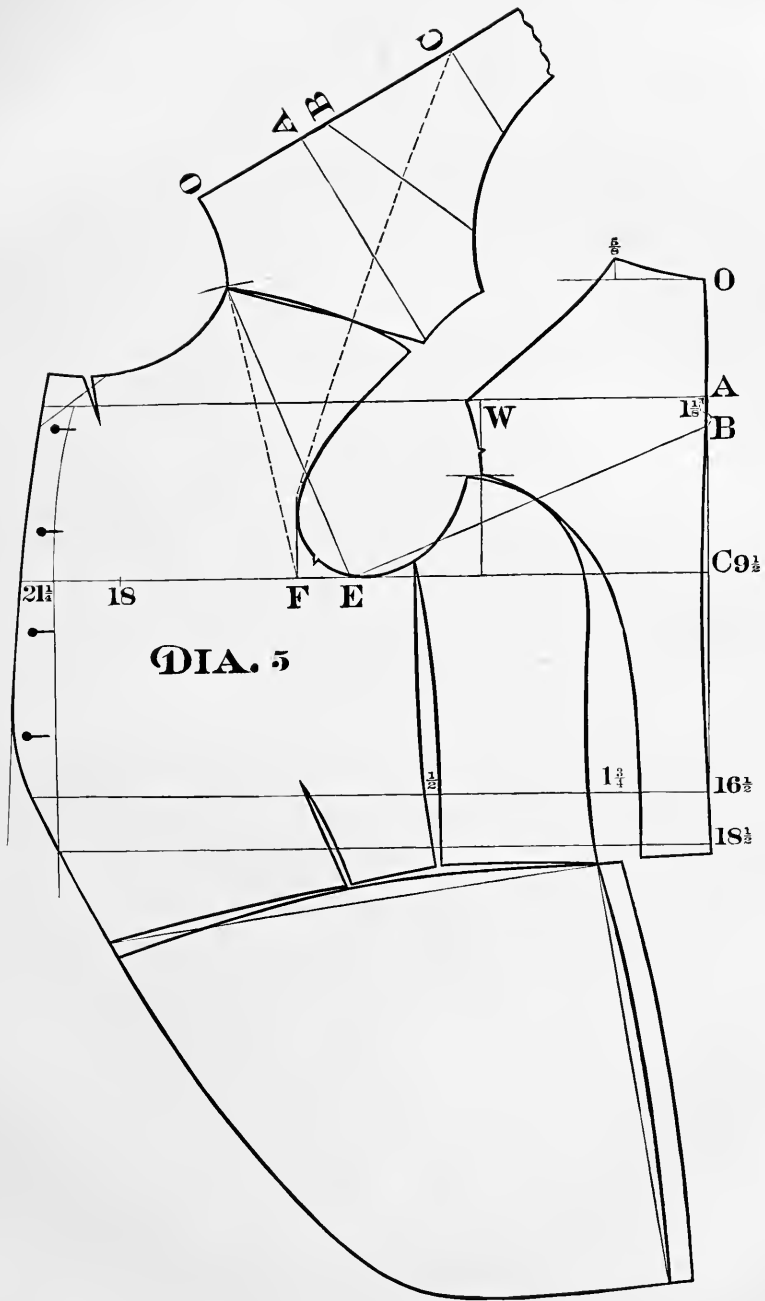

## DIAGRAM 6. D. B. FROCK.

MEASURES.	$8\frac{3}{4}$ $16\frac{1}{2}$ $18\frac{1}{2}$ 37	$\left. \begin{array}{l} \text{Lengths.} \\ \text{Lengths.} \end{array} \right\}$	Front of Scye $11\frac{1}{2}$ First over Measure $12\frac{1}{4}$ Second over Measure 18 Breast 36, Waist 32, Hip .35	$\left. \begin{array}{l} \text{Sleeve.} \\ 7\frac{1}{4} \\ 20 \\ 31 \end{array} \right\}$
-----------	--	---	---	---

### DRAFT PRODUCED BY THE MEASURES.

**A** RRANGE measures by which to draft as follows ;

Add  $\frac{3}{4}$  to depth of scye,  $8\frac{3}{4}$ — $9\frac{1}{2}$  inches ;

Add 1 to front of scye,  $11\frac{1}{2}$ — $12\frac{1}{2}$  inches ;

Add  $\frac{3}{4}$  to front of scye to square shoulder by,  $11\frac{1}{2}$ — $12\frac{1}{4}$  inches ;

Add  $\frac{1}{2}$  to first over measure,  $12\frac{1}{4}$ — $12\frac{3}{4}$  inches ;

Deduct  $\frac{1}{4}$  from second over measure,  $18$ — $17\frac{3}{4}$  inches ;

Draw line for back seam ; square across as at O ;

Rise of neck is  $\frac{3}{8}$  of an inch ; width of top of back is  $2\frac{3}{4}$  inches ;

From O to C is  $9\frac{1}{2}$  inches ; From O to natural waist is  $16\frac{1}{2}$ , the fashionable waist is  $18\frac{1}{2}$ , full length is 37 inches ;

B is half way between O and C ; A is  $1\frac{1}{3}$  from B ;

From A to W is  $7\frac{1}{4}$  inches ; square down as illustrated ;

Form shoulder seam of back ;

From W to top of side seams is  $2\frac{1}{4}$  (18 on 8ths) ;

Form side seams taking out at blade  $\frac{1}{2}$  inch and at natural waist  $1\frac{3}{4}$  inch ;

Width of back at natural waist is  $2\frac{1}{4}$  inches ;

From C to F is  $12\frac{1}{4}$  inches ;

Square up 3 inches as illustrated ;

From C, measure across  $\frac{1}{3}$  of Breast 18 inches, allowing  $\frac{3}{4}$  for reduction at back seam and blade— $18\frac{3}{4}$  inches ;

Add  $2\frac{1}{4}$  inches and square down ;

Sweep up from C, for front of breast ;

Form under arm seams, taking out  $\frac{1}{2}$  inch at natural waist ;

Measure for front of waist  $\frac{1}{2}$  of waist measure 16, adding  $2\frac{1}{4}$  for making up  $18\frac{1}{4}$  inches ;

Form front as illustrated ;

At B, lay one arm of square at  $12\frac{1}{4}$  inches, letting the angle of square rest on breast line at E ; square up by the other arm ;

From F sweep across this line by first over measure ;

Deduct width of top of back which gives shoulder point ;

Cut out back, and lay in closing position at shoulder, and form shoulder seam by second over measure  $17\frac{3}{4}$  inches ;

Reduce at point of scye scant  $\frac{1}{2}$  inch, and shape scye as illustrated ;

Back pitch is on 12ths from W ;

Form gorge raising at front  $\frac{3}{4}$  inch ;

Follow the illustration taking out a small V ;

Sweep for length of front, at 1 inch behind shoulder point, by length of side seam, and finish draft as illustrated.



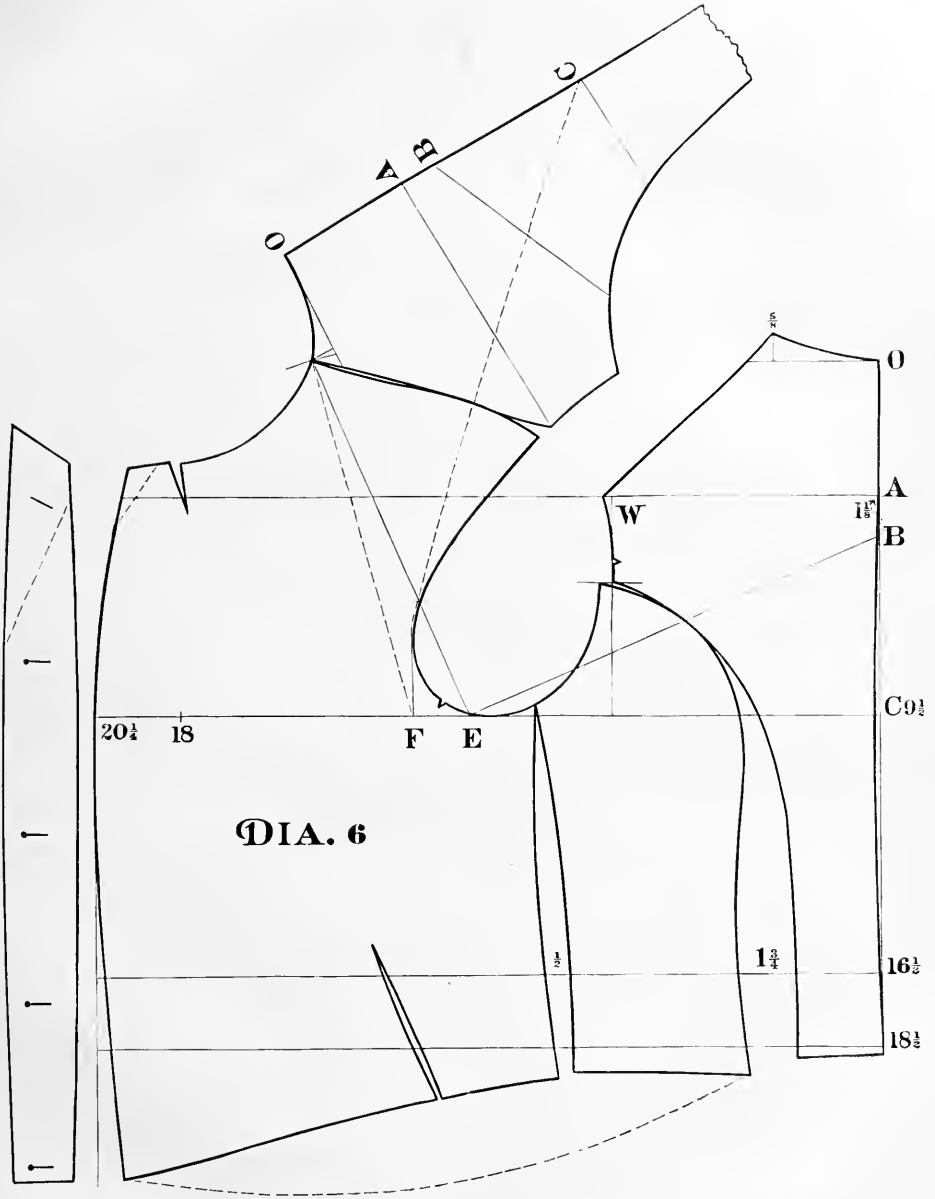

## DIAGRAM 7. D. B. FROCK.

## CORPULENT FIGURE.

MEASURES.	$9\frac{3}{4}$ $18\frac{1}{4}$ $20\frac{1}{4}$	Lengths	{	Front of scye $13\frac{1}{4}$ First over measure 14 Second over measure $20\frac{3}{4}$	}	Sleeve 8 21 33
				Breast 43. Waist 45.		

## DRAFT PRODUCED BY MEASURES.

- A** RRANGE measures by which to draft as follows:
- Add  $\frac{3}{4}$  to depth of scye,  $9\frac{3}{4}$ — $10\frac{1}{2}$  inches;
  - Add 1 to front of scye,  $13\frac{1}{4}$ — $14\frac{1}{4}$  inches;
  - Add  $\frac{3}{4}$  to front of scye to square shoulder by,  $13\frac{1}{4}$ —14 inches,
  - Add  $\frac{1}{2}$  to first over measure, 14— $14\frac{1}{2}$  inches.
  - Deduct  $\frac{1}{4}$  from second over measure,  $20\frac{3}{4}$ — $20\frac{1}{2}$  inches.
  - Draw line for back seam; Square across as at O;
  - On 8ths from O square up;
  - Make rise of neck  $\frac{5}{8}$  inch; Width of top of back to fancy;
  - From O to C is  $10\frac{1}{2}$  inches; From O to natural waist is  $18\frac{1}{4}$  to fashionable waist  $20\frac{1}{4}$  inches; B is half way between O and C;
  - A is  $1\frac{1}{2}$  inch above B; A to W is 8 inches; square down to breast line;
  - Top of side seams is on 8ths from W;
  - Form side seams taking out  $\frac{1}{2}$  inch at blade and  $1\frac{1}{2}$  inch at natural waist;
  - Width of back at natural waist is  $\frac{1}{3}$  ( $21\frac{1}{2}$  on 8ths);
  - From C to F is  $14\frac{1}{4}$  inches;
  - Square up for front of scye as illustrated;
  - From C measure size of breast  $21\frac{1}{2}$  inches allowing  $\frac{3}{4}$  inch for reduction at blade and at back seam,  $22\frac{1}{4}$  inches;
  - Add  $2\frac{1}{4}$  inches and square down; sweep front by C;
  - At B lay arm of square at 14 inches letting the angle of square fall on breast line at E; Square upward by the other arm;
  - Sweep from F across this line by the first over measure,  $14\frac{1}{2}$  inches;
  - Take off width of top of back for shoulder point;
  - Cut out back and place in closing position at shoulder point;
  - Form shoulder seam by second over measure  $20\frac{1}{2}$  inches;
  - Reduce at point of scye  $\frac{1}{2}$  inch; Form scye as illustrated;
  - Form gorge raising at front  $\frac{3}{4}$  inch;
  - Form under arm seams taking out  $\frac{1}{2}$  inch at natural waist;
  - Sweep for length of front at 1 inch behind shoulder point;
  - Cut out side-body; Place back and side-body in closing position at waist;
  - Measure for waist, adding  $2\frac{3}{4}$  inches;
  - Form front as illustrated;
  - In forming waist seam take out two V's running each within  $1\frac{1}{2}$  inch of the natural waist line;
  - That a Coat may button easily at the waist for a corpulent figure more is allowed than usual, which extra allowance ( $\frac{1}{2}$  inch) is used up in the extra V.

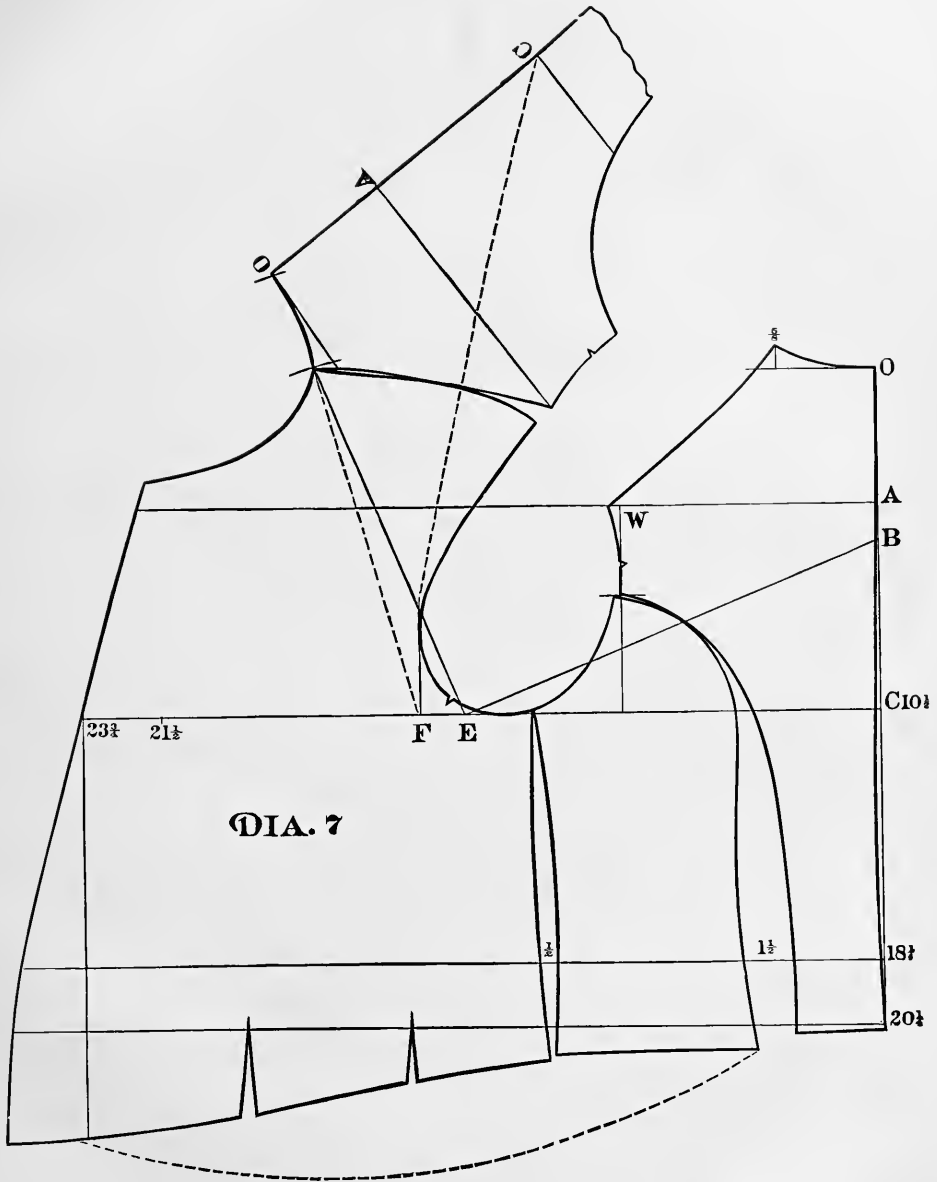

## DIAGRAM 8. DRESS COAT.

MEASURES.	$\left. \begin{array}{l} 8\frac{3}{4} \\ 16\frac{1}{2} \\ 18\frac{1}{2} \\ 36\frac{1}{2} \end{array} \right\} \text{Lengths.}$	$\left. \begin{array}{l} \text{Front of scye } 11\frac{1}{2} \\ \text{First over measure } 12\frac{1}{4} \\ \text{Second over measure } 18 \\ \text{Breast } 38. \quad \text{Waist } 32. \end{array} \right\} \text{Sleeve.}$	$\left. \begin{array}{l} 7\frac{3}{4} \\ 20 \\ 30\frac{1}{2} \end{array} \right\}$
-----------	--	---	--

### DRAFT PRODUCED BY THE MEASURES.

- A** RRANGE Measures by which to draft as follows :
- Add  $\frac{3}{4}$  to depth of scye,  $8\frac{3}{4}$ — $9\frac{1}{2}$  inches ;  
 Add 1 to front of scye,  $11\frac{1}{2}$ — $12\frac{1}{2}$  inches ;  
 Add  $\frac{3}{4}$  to front of scye to square shoulder by,  $11\frac{1}{2}$ — $12\frac{1}{4}$  inches .  
 Add  $\frac{1}{2}$  to first over measure,  $12\frac{1}{4}$ — $12\frac{3}{4}$  inches ;  
 Deduct  $\frac{1}{4}$  from second over measure,  $18$ — $17\frac{3}{4}$  inches .  
 Draw line for back seam ; Square across as at O ;  
 On 8ths from O square up ;  
 Make rise of neck  $\frac{3}{8}$  inch ; Width of top of back to fancy ;  
 From O to C is  $9\frac{1}{2}$  inches ; From O to natural waist is  $16\frac{1}{2}$ , to fashionable waist  $18\frac{1}{2}$  ; B is half way between O and C ; A is  $1\frac{1}{8}$  inch above B ; A to W is  $7\frac{1}{4}$  inches ;  
 Square down to breast line ; Top of side seams is on 8ths from W ;  
 Form side seams taking out  $\frac{1}{2}$  inch at blade and  $1\frac{3}{4}$  inch at natural waist ;  
 From C to F is  $12\frac{1}{4}$  inches ; Square up for front of scye as illustrated ;  
 From C measure size of breast 18 inches, allowing for reduction at blade  $\frac{1}{2}$  inch and square down ; add  $1\frac{3}{4}$  ; Sweep front by C ;  
 At B lay arm of square at  $12\frac{1}{4}$  inches letting the angle fall on breast line at E ;  
 Square up by the other arm ;  
 Sweep from F across this line by first over measure  $12\frac{3}{4}$  inches ,  
 Take off width of top of back for shoulder point ;  
 Cut out back ; and place in closing position at shoulder point ;  
 Form shoulder seam by second over measure  $17\frac{3}{4}$  inches .  
 Form scye as illustrated ;  
 Form neck gorge raising at front  $\frac{1}{2}$  inch and reducing by V as illustrated ;  
 Form under arm seams taking out  $\frac{1}{2}$  inch at natural waist ;  
 Sweep for length of front at 1 inch behind shoulder point ;  
 Reduce length of front  $\frac{3}{8}$  of an inch on account of strap of skirt ;  
 Finish draft as illustrated reducing lapel seam at waist, to the prevailing style ;  
 The Diagram is reduced  $1\frac{1}{2}$  inch full ; Back pitch is on 12ths from W .

### TO DRAFT THE SKIRT.

- Draw line A B ; From A at 9 inches down, square out  $1\frac{1}{2}$  inch for spring of plait  
 Square across at A for waist ; Six inches from A ; square up  $\frac{1}{2}$  inch ;  
 Measure for size of waist ; Drop at front  $\frac{1}{4}$  inch ;  
 Draw waist seam to fit fore part ; Make skirt to length required ;  
 Draw front of skirt as illustrated ; Width of skirt at bottom  $\frac{1}{4}$  .

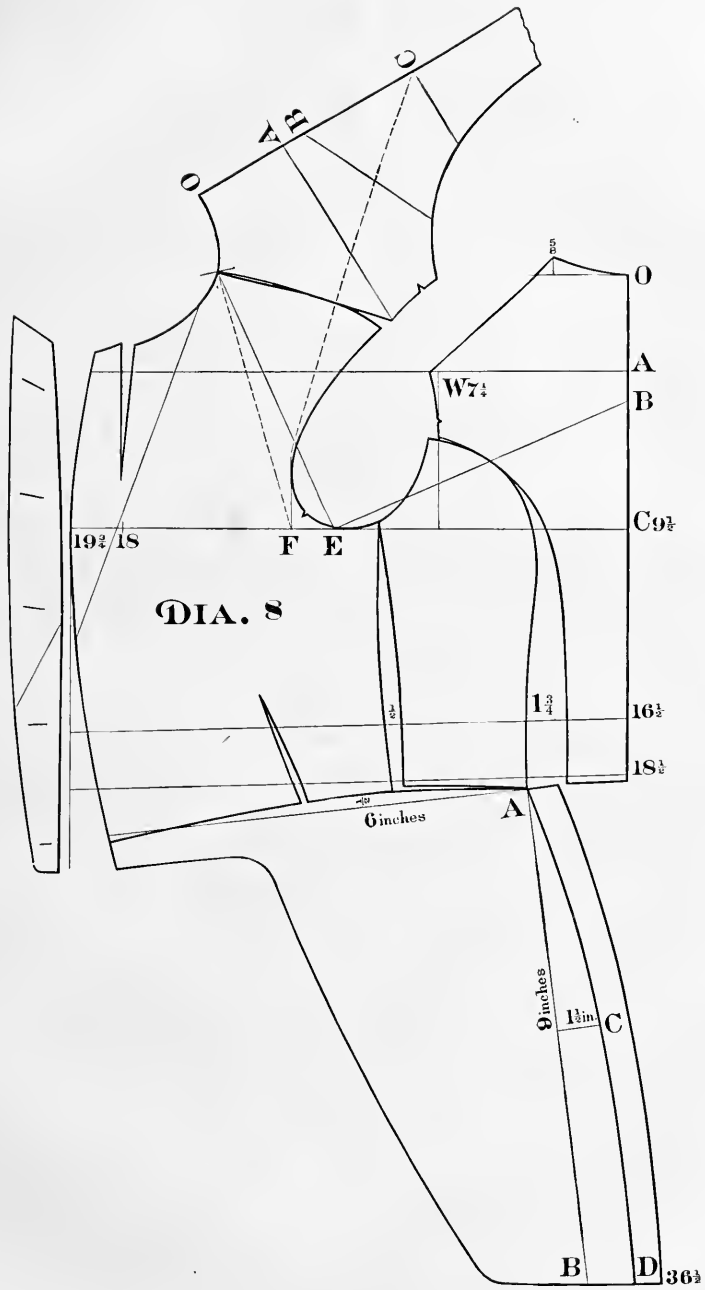

---



---

## DIAGRAM 9. SLEEVE.

**S**QUARE lines for top and hind arm ;  
 From O mark off on hind arm  $1\frac{1}{2}$  and  $3\frac{3}{4}$  inches always ; Square out from these points ; On the lower line mark off 6 inches always ;  
 From point at  $1\frac{1}{2}$ , draw diagonal line through point 6 to A ; Make this diagonal line  $\frac{1}{2}$  of the scye measure ; Square down from A to B for forearm ;  
 Form sleeve head as illustrated ;

### UNDERSIDE.

From point  $1\frac{1}{2}$  on the diagonal line mark off  $\frac{2}{3}$  of its length and square down  $1\frac{1}{4}$  inch as illustrated ;  
 Measure underside  $\frac{1}{4}$  inch more than under half of scye, spacing equally at fore and hind arm seams as illustrated ;  
 Measure for elbow and full length deducting width of back ;  
 Sweep for length of forearm by full length, from top of hind arm ;  
 Finish draft making seams at fore arm of top and underside of equal length  
 It will be seen on the Diagram that the top half at hand is widened 1 inch and the under half reduced correspondingly, to place the forearm seam well under at the hand. The over erect figure will require the top of hind arm to be shortened  $\frac{2}{3}$  of an inch more or less, the other points remaining the same ; for the stooping figure lengthen the top of hind arm, the same quantity.

---

## DIAGRAMS 10-11. SKIRTS.

**T**O draft a Skirt is simply to fit it to the waist seams so as to produce the given amount of drapery required by the prevailing style. The Cutaway is as close and devoid of drapery as it is possible to wear without inconvenience ; while the Frock (single and double breasted) is subject more or less to the caprice of Fashion in this particular. This necessitates a change in the details of the draft for every change of style. By the Diagram it will be seen that a very slight departure from the square gives enough of drapery for the Cutaway skirt :

To draft Cutaway Skirt place the angle of square as at A and square over and down ; From A make skirt to measure at D ; Mark off full length of skirt on plait ; Raise waist seam at 6 inches from A, one inch ; Form waist seam dropping at D, a scant  $\frac{1}{2}$  inch ;

Spring plait  $\frac{1}{2}$  inch at 9 inches down from A and form plait as illustrated ;

Place skirt in closing position at waist and form front line more or less cutaway according to prevailing style.

The Single or Double Breasted Frock Skirt as now worn is pretty close to the form, and by following the Diagram a good skirt for general use may be produced :

Lay angle of square as at A and draw lines over and down ;

From A measure over 9 inches and square up  $1\frac{1}{4}$  inch.

At A raise  $1\frac{1}{2}$  inch, mark off from A to B necessary size of waist, allowing for fullness, and square down to C ; Form waist seam as illustrated ; From A on plait line go down 9 inches and square out 2 ; Form curve of plait passing through point A and 2 inches spring, to length required ; Sweep for bottom at equal distance from waist seam, giving a little more round at the center of the sweep.

---

## DIAGRAM 14. COLLAR.

From O square over and down ; From O to A is  $2\frac{1}{4}$  inches ; O to B length of neck and a seam ; Finish as illustrated.

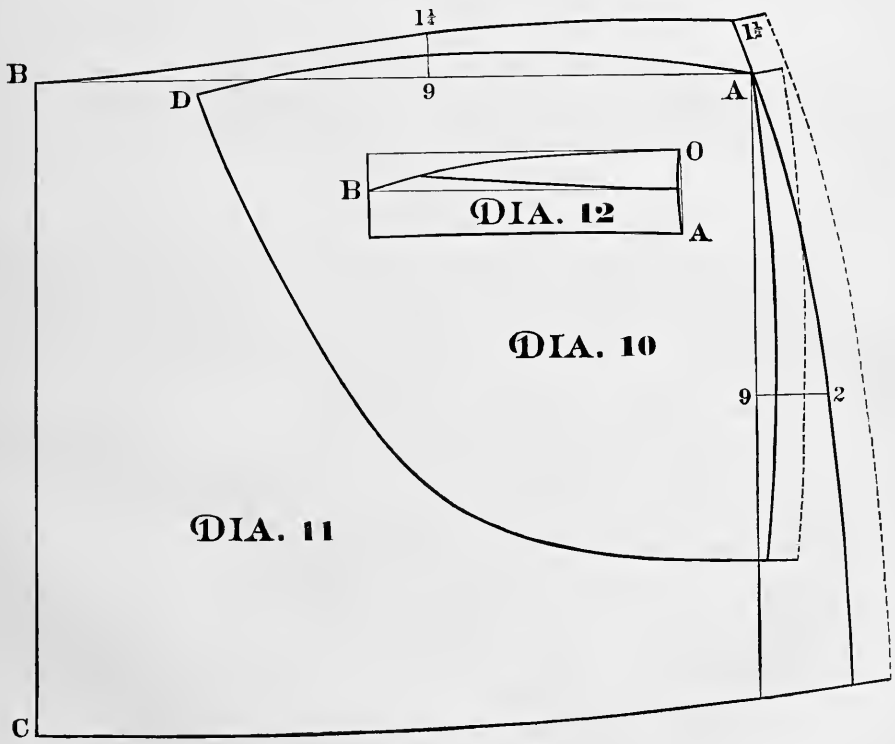
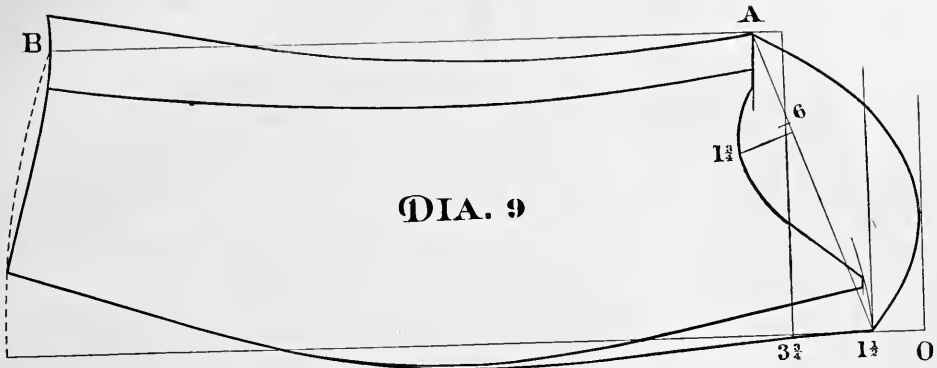

## DIAGRAM 13. SLEEVE OF OVERSACK.

Changed to suit lowered back pitch. See page 14 Diagram 3.

THE solid lines show the top and underside as drafted for the usual depth of back pitch; the dotted lines, the increase made on the top side, and the corresponding decrease on the under side—the principle is simple enough; top of hind arm at point  $1\frac{1}{2}$ , would be sewn in at the regular back pitch, as that point is lowered, the hind arm seam must be lowered the same—the top side will be that much wider, the under side the same amount narrower; the seam is put in another place preserving the correct lengths to balance the sleeve with the altered back pitch.

## DIAGRAM 14. BACK AND BACK SKIRT.

TO DRAFT BACK SKIRT.

DRAW line A B full length of Coat one inch in from the edge of cloth;  
 Place back in position as illustrated;  
 According to the attitude or inclination of the figure  $\frac{3}{4}$  to 2 inches at natural waist from line A B;  
 To know how much, take the indentation by the square at the natural waist of the customer;  
 Square across at bottom of back skirt as illustrated;  
 Square up to bottom of side seam at hip;  
 Round slightly for plait;  
 Mark off back tack;  
 Draw line from B to C;  
 Allow for turning in of back skirt and finish draft as illustrated;  
 Should the figure be over erect and give more than  $1\frac{1}{2}$  inch as the indentation at hollow of waist, the back skirt will be produced too wide at the bottom to look well; reduce to the desired width at bottom and add the amount reduced whether  $\frac{1}{2}$  inch or  $1\frac{1}{2}$  inch, to the plait of the skirt;  
 The principle of this method in drafting the back skirt is to get it of the same attitude or inclination as that of the figure it is intended to cover; in the case of the over erect figure it prevents the opening of the back skirts, and in the stooping figure, it avoids the lapping of the same; two errors frequently seen and which gives, in the case of the over erect figure, considerable trouble to correct.



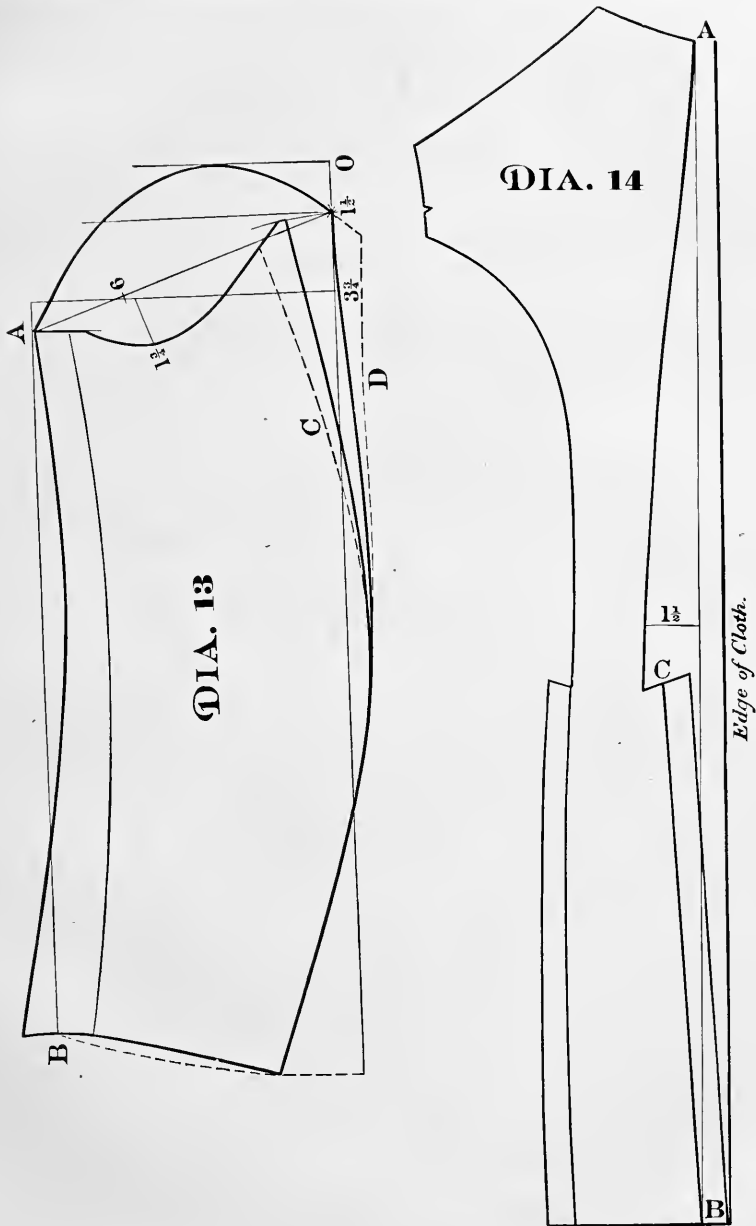

## DIAGRAM 15. S. B. VEST ;

MEASURES.	Breast	36	} Level of Scye	8 $\frac{3}{4}$	} {	Front balance	19 $\frac{1}{2}$			
	Waist	32		Natural Waist			17	Back	"	19 $\frac{1}{2}$
	Top button	10 $\frac{1}{2}$		Front of Scye			11 $\frac{1}{2}$	} Slope of shoulder	20-25 $\frac{1}{4}$	
	Full length	25		First over Measure			12 $\frac{1}{4}$			

## DRAFT PRODUCED BY THE MEASURES.

- A** DD  $\frac{3}{4}$  to Scye depth, 8 $\frac{3}{4}$ —9 $\frac{1}{2}$  inches ;  
 Add 1 inch to front of scye, 11 $\frac{1}{2}$ —12 $\frac{1}{2}$  inches ;  
 Add  $\frac{3}{4}$  to front of scye to square shoulder by, 11 $\frac{1}{2}$ —12 $\frac{1}{4}$  inches ;  
 Add 1 inch to front balance, 19 $\frac{1}{2}$ —20 $\frac{3}{8}$  inches ;  
 Add  $\frac{1}{2}$  to back balance, 19 $\frac{1}{2}$ —19 $\frac{3}{4}$  inches ;  
 Add  $\frac{1}{2}$  to 1st over measure, 12 $\frac{1}{4}$ —12 $\frac{3}{4}$  inches ;  
 Add  $\frac{1}{2}$  to 2nd over measure, 18—18 $\frac{1}{2}$  inches ;  
 Draw line for back seam ; Square across as at O ; From O to C is 9 $\frac{1}{2}$  inches ;  
**B** is halfway between O and C ; From O to D is  $\frac{1}{2}$  and a good seam ;  
 At D square up  $\frac{5}{8}$  for rise of neck ; Width of top of back to fancy ;  
 From B to W is  $\frac{1}{4}$  and  $\frac{1}{12}$  ; Square up from W ; From C to F is 12 $\frac{1}{2}$  inches ;  
 Measure across  $\frac{1}{2}$  of breast measure 18, and add 2 $\frac{1}{2}$  for making up, 20 $\frac{1}{2}$  inches ; ;  
 Square down for front ; Sweep up by C for size of neck ;  
 Square up from F for front of scye, 4 inches ;  
 At B lay one arm of square at 12 $\frac{1}{4}$  inches, letting the angle of square rest on  
 breast line at E ; Square up by the other arm ;  
 From F sweep across this line by 1st over measure ;  
 Deduct width of top of back, which gives shoulder point ;  
 From shoulder point, draw line to B for shoulder seam of fore part and where  
 it cuts the line squared up from W, will give the shoulder seam of back ;  
 Form both shoulder seams, and scye as illustrated, clearing at F,  $\frac{1}{2}$  inch ;  
 Measure for top button, allowing  $\frac{3}{4}$  for seams. Measure for length 25, and square  
 across to back seam ; Add 1 inch for seams and making up ;  
 Form bottom as illustrated ; Divide draft in halves ; Square line down ;  
 Take out 1 inch on each side of line, at natural waist ;  
 Reduce  $\frac{3}{4}$  at natural waist on back seam ; and at top  $\frac{1}{4}$  of an inch ;  
 Fit collar as illustrated ; Before cutting out scye, apply front and back balance  
 check measures as illustrated ;

The measures are taken as per dotted lines, at  $\frac{1}{4}$  of the waist measure from back seam, at the *natural waist just above the hip*; in the regular proportioned figure these measures will be alike; on large or small waists, stooping or over-erect figures they will vary; in applying the measures add  $\frac{1}{4}$  to back balance, and 1 inch to the front balance; measure from O each way and make a mark at natural waist; cut out the back and place the marks together in closing position; the back may be too long or too short according to the requirement of the figure—if so rectify the run of scye at bottom accordingly.

The most common fault in Vest cutting is to get the shoulder too tight at the point of scye; this will cause the shoulder to wrinkle and throw all the other points out so much as to give the appearance of a general misfit, and yet very few cutters apply any measure to close the shoulder, relying on the ordinary proportions and their memory of the figure; The 20-25 $\frac{1}{4}$  measure, in connection with the two check balance measures is invaluable in the use of a set of Vest Patterns.

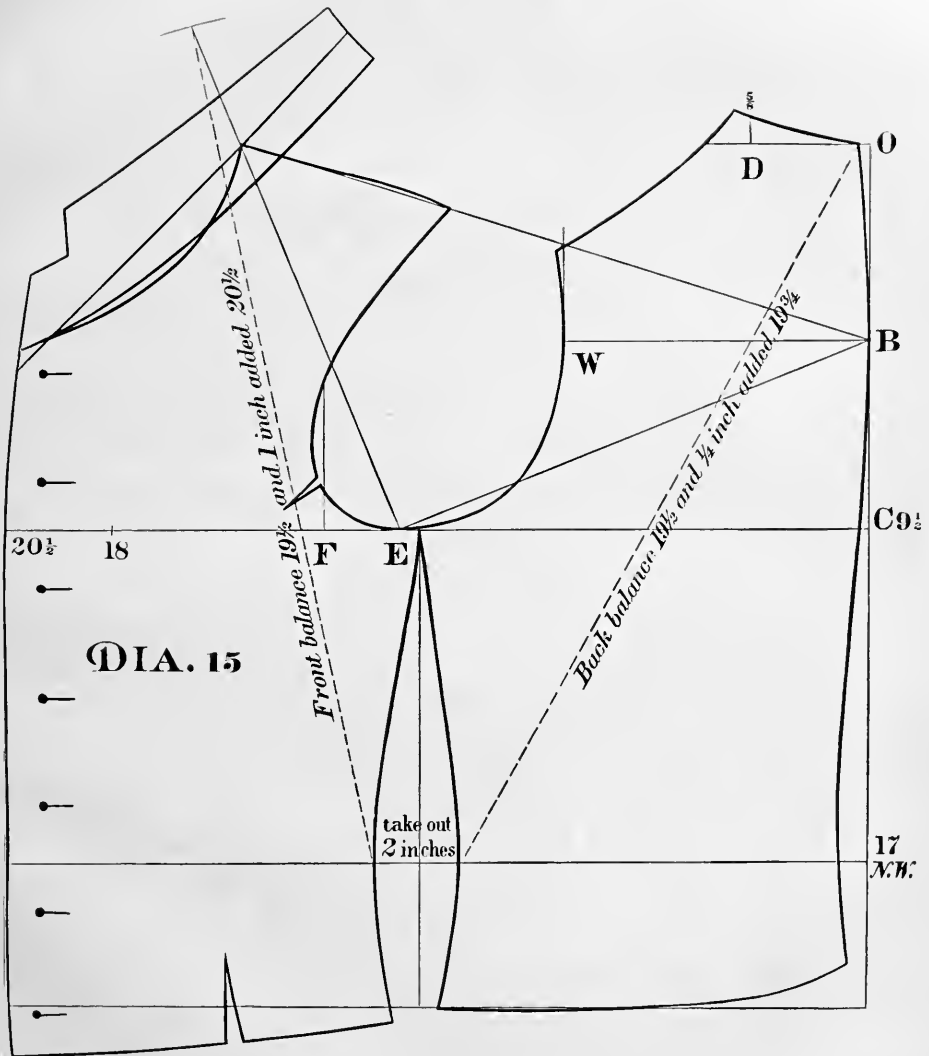

## DIAGRAM 16. CORPULENT VEST.

MEASURES.	Breast, 43	}	Level of scye, $9\frac{3}{4}$	}	Front balance, $21\frac{3}{4}$
	Waist, 46		Natural waist, $18\frac{1}{2}$		Back balance, $22\frac{1}{4}$
	Top button, 14		Front of scye, $13\frac{1}{2}$		First over-measure, 14.
	Full length, 28				

### DRAFT PRODUCED BY THE MEASURES.

- A** DD  $\frac{3}{4}$  to scye depth  $9\frac{3}{4}$ - $10\frac{1}{2}$  inches.  
 Add 1 to front of scye  $13\frac{1}{2}$ - $14\frac{1}{2}$  inches.  
 Add  $\frac{3}{4}$  to front of scye to square by shoulder  $13\frac{1}{2}$ - $14\frac{1}{2}$  inches.  
 Add 1 inch to front balance  $21\frac{3}{4}$ - $22\frac{3}{4}$  inches.  
 Add  $\frac{1}{2}$  to back balance  $19\frac{1}{2}$ - $19\frac{3}{4}$  inches.  
 Add  $\frac{1}{2}$  to first over-measure  $14$ - $14\frac{1}{2}$  inches.  
 Draw line for back seam; square across as at O.  
 From O to C is  $10\frac{1}{2}$  inches; to natural waist  $18\frac{1}{2}$  inches; B is half way between O and C.  
 From O to D is  $\frac{1}{8}$  and a good seam.  
 At D square up  $\frac{5}{8}$  for rise of neck; width of top of back to fancy.  
 From B to W is  $\frac{1}{8}$  and  $\frac{1}{2}$ ; square up from W.  
 From C to F is  $14\frac{1}{2}$  inches.  
 Measure across  $\frac{1}{2}$  of breast measure  $21\frac{1}{2}$ , and add  $2\frac{1}{2}$  for making up,  $24$  inches.  
 Square down, and sweep up by C as illustrated.  
 Square up from F for front of scye,  $4$  inches.  
 At B lay one arm of square at  $14\frac{1}{2}$  inches, letting the angle fall at E and square up by the other arm.  
 From F sweep across this line by first over-measure; deduct width of top of back, which gives shoulder point.  
 From shoulder point, draw line to B for shoulder seam of forepart, and where it cuts the line squared up from W, will give shoulder seam of back.  
 Form both shoulder seams and scye as illustrated, clearing at F,  $\frac{1}{2}$  inch.  
 Measure for top button, allowing  $\frac{3}{4}$  for seams.  
 Measure for length of vest 28 inches, and square across to back seam.  
 Add 1 inch for making up.  
 Form bottom as illustrated; divide draft in halves; square line down.  
 Reduce  $\frac{3}{4}$  at natural waist on back seam and  $\frac{1}{4}$  at top; form back seam as illustrated.  
 Measure across draft at natural waist for size of waist, adding 2 inches for making up; waist being 3 inches larger than breast nothing will be taken out under arm at natural waist; spring under arm seams and form front as illustrated.  
 \*Point for front and back balance will be on fore part, owing to size of waist.  
 Find this point by measuring across  $\frac{1}{4}$  of waist, allowing for seams, and apply front and back balance as illustrated.

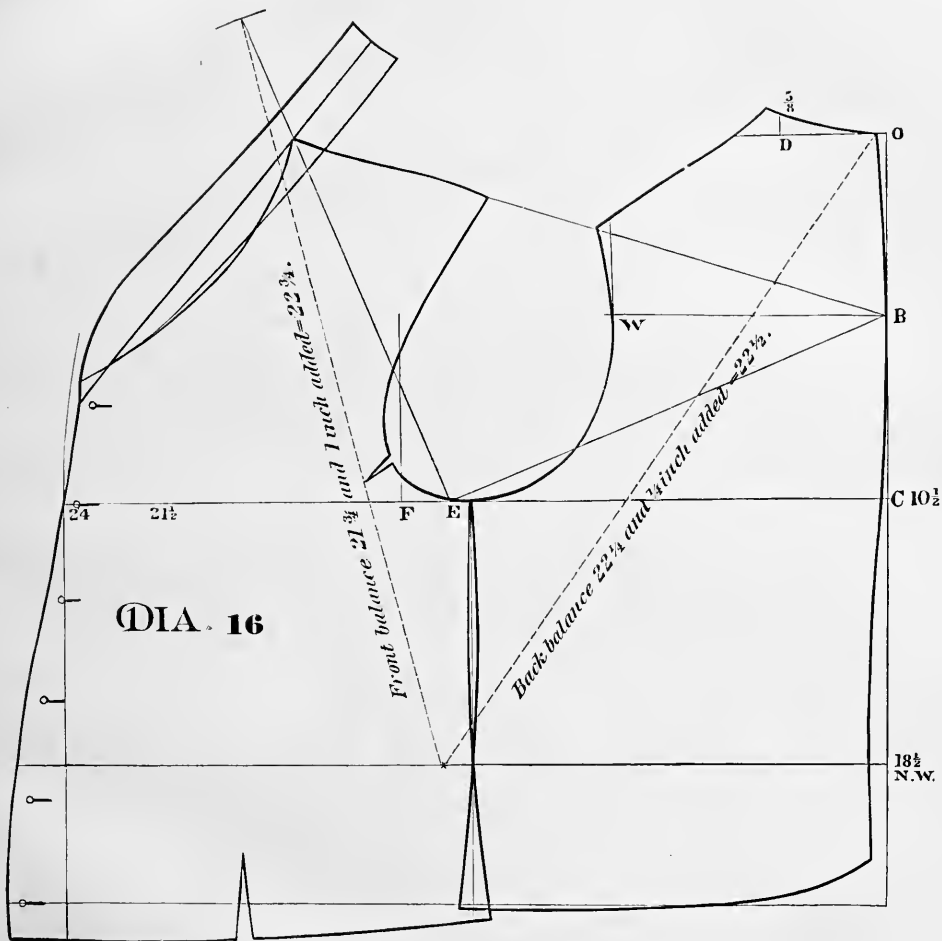

## DIAGRAM 17. D. B. VEST.

### LAPELS CUT OFF.

MEASURES.	Breast	36	}	Level of Scye	$8\frac{3}{4}$	}	Front balance	$19\frac{1}{2}$
	Waist	32		Natural Waist	17		Back balance	$19\frac{1}{2}$
	Full length	26		Front of Scye	$11\frac{1}{2}$		Slope of shoulder	$20-25\frac{1}{4}$
				First over Measure	$12\frac{1}{4}$			

### DRAFT PRODUCED BY THE MEASURES.

- A** DD  $\frac{3}{4}$  to scye depth,  $8\frac{3}{4}-9\frac{1}{2}$  inches ;  
 Add 1 inch to front of scye,  $11\frac{1}{2}-12\frac{1}{2}$  inches ;  
 Add  $\frac{3}{4}$  to front of scye to square shoulder by,  $11\frac{1}{2}-12\frac{1}{4}$  inches.  
 Add  $\frac{1}{2}$  to first over measure,  $12\frac{1}{4}-12\frac{3}{4}$  inches.  
 Draw line for back seam ; Square across as at O ;  
 From O to C is  $9\frac{1}{2}$  inches ; B is half way between O and C ; O to D is  $\frac{1}{2}$  and a good seam ;  
 At D square up  $\frac{5}{8}$  for rise of neck ; Width of top of back to fancy ;  
 From B to W is  $\frac{1}{2}$  and  $\frac{1}{12}$  ; Square up from W.  
 From C to F is  $12\frac{1}{2}$  inches ;  
 Measure across  $\frac{1}{2}$  of Breast 18 inches add  $1\frac{1}{2}$ , if wadded add 2 inches ;  
 Square down for lapel seam ; Sweep up by C for size of neck ; Square up from F for front of scye ;  
 At B lay one arm of square at  $12\frac{1}{4}$  inches, letting the angle of square rest on breast line at E : Square up by the other arm ;  
 From F sweep across this line by the first over measure,  $12\frac{3}{4}$  inches ;  
 Deduct width of top of back, which finds the shoulder point ;  
 From the shoulder point, draw line to B for shoulder seam of fore part, and where it cuts the line squared up from W, will give the shoulder seam of back ;  
 Form both shoulder seams ;  
 Form scye as illustrated clearing it at F,  $\frac{1}{2}$  inch ;  
 Measure for top button allowing  $\frac{3}{4}$  for seams ;  
 Measure for length of Vest 26, and square across to back seam ;  
 Add 1 inch for seams and making up ; Form bottom as illustrated ;  
 Divide draft in halves ; Square line down ;  
 Take out 1 inch on each side of line at natural waist ; Reduce  $\frac{3}{4}$  at natural waist on back seam ;  
 Fit collar as illustrated ;  
 Draft lapel according to prevailing style ;  
 The button line will be the same distance from the lapel seam as the corresponding button hole.

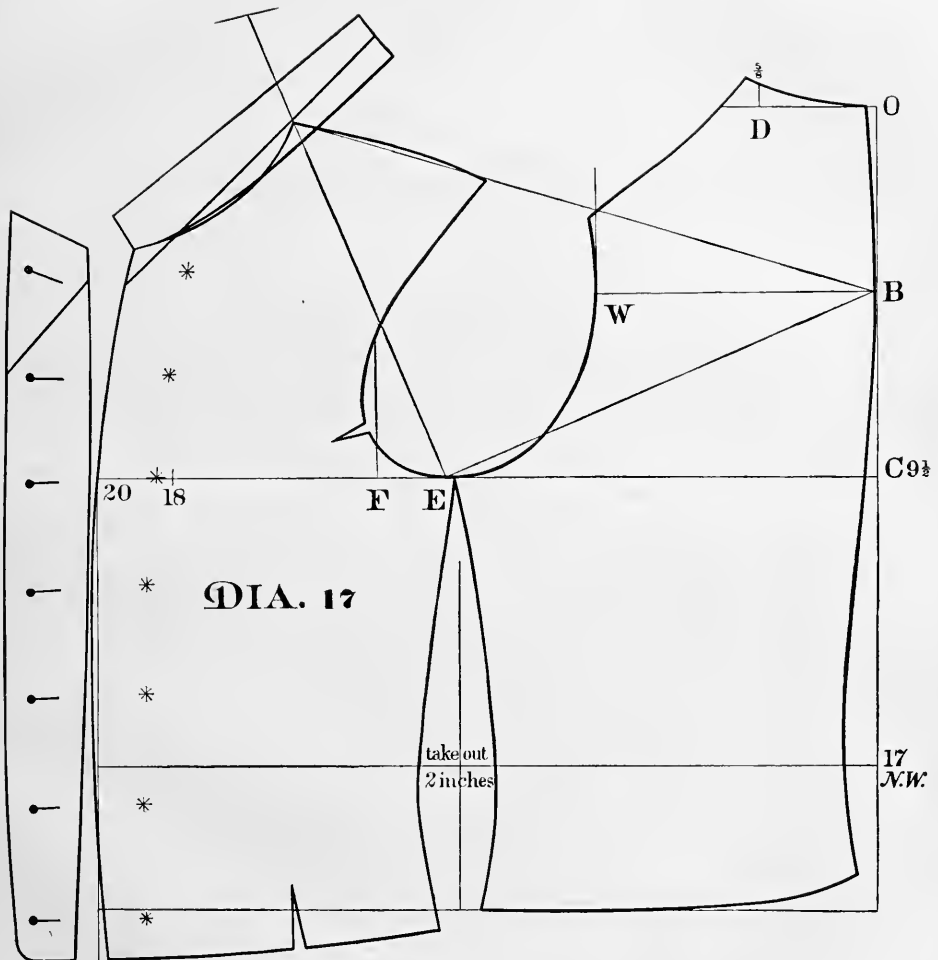

## DIAGRAM 18. CAPE OR CLOAK.

MEASURES.  $\left\{ \begin{array}{l} \text{Front length 38} \\ \text{Over shoulder 42} \\ \text{Back length 40} \end{array} \right\}$  Breast 36  
on the Vest.

DRAFT BY DIVISIONS OF THE BREAST MEASURE TAKEN ON THE VEST.

**D**RAW front line A O ;

Square down for back seam :

From A to B is  $\frac{1}{3\frac{1}{2}}$  less than  $\frac{1}{4}$  ;

From B to C same distance as A to B ;

From C to D is  $\frac{1}{2}$  distance of B to C ;

From D to F same as from A to D ;

From C to E same as from A to B ;

Measure from F to E, and make F to G  $\frac{3}{4}$  inch longer and sew on the fullness stretching E F to it when pressing the seam ;

From A to I same as from A to C ;

Draw slash the shape of ordinary shoulder seam ;

Front from D, measure of front length—38 ;

From E over shoulder—42 ;

From I—40 inches ;

Sweep bottom through lengths given ;

Add button step or lapel as required and finish draft as illustrated ;

This is a closer Cape or Cloak than that of Diagram 19, and is known as the  $\frac{1}{2}$  circle ;

Back seam on crease edge of goods.



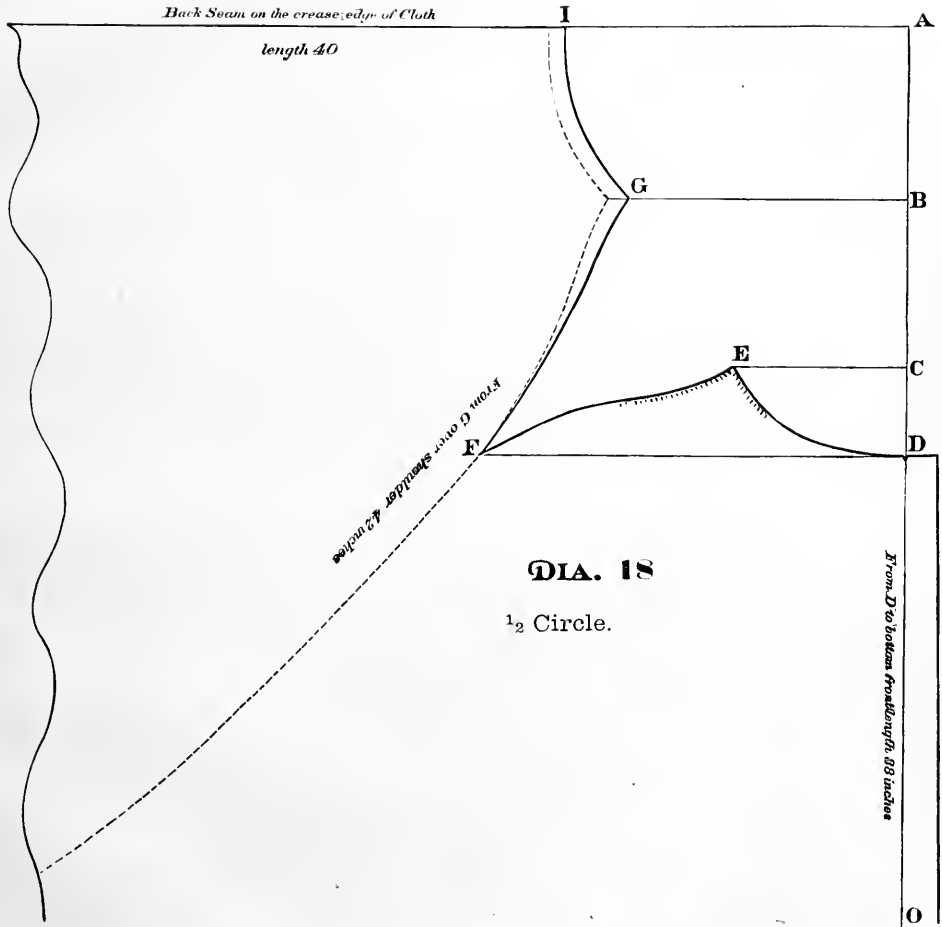

## DIAGRAM 19. CAPE OR CLOAK.

MEASURES.	{	Front length 38 Over shoulder 42 Back length 40	}	Breast 38 over the coat.
-----------	---	---	---	-----------------------------

CUT BY THE OVER SACK DRAFT.

PLACE the Draft of over Sack which fits the figure in position as illustrated ;

Open the shoulder at neck,  $1\frac{1}{2}$  inch ;

Close shoulder at scye point ;

This position gives a  $\frac{3}{4}$  circle ;

If less fullness is required, open the shoulder slash still more ;

If required double breasted add 1 inch more at front all through for lapel, and place the buttons correspondingly farther back.

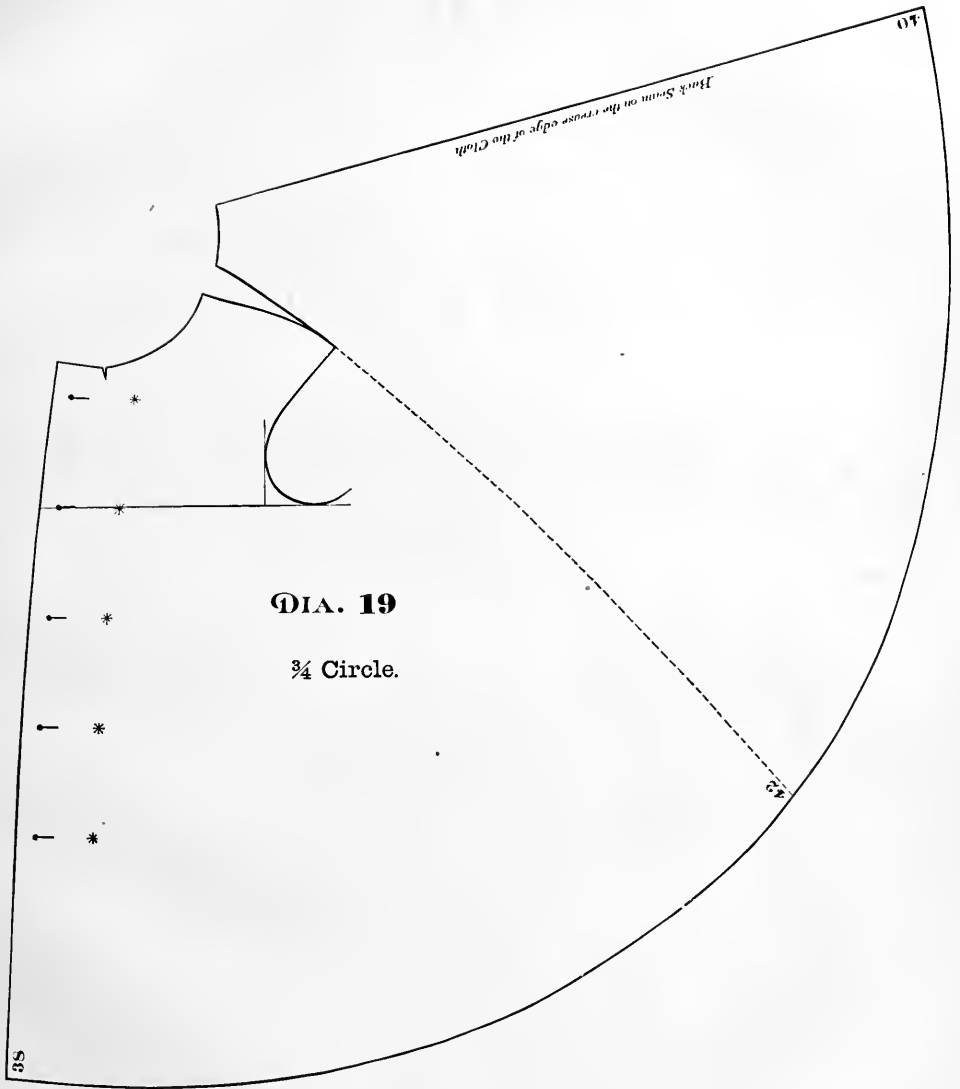



## PANTALOONS.

IT would appear a very simple matter to drape the leg and form a wrap around the seat and waist; but simple as the problem appears a good fitting pair of Pantaloons is rare to see. "Infallible" Systems nevertheless reckon by the thousand and their apparent diversity is increased to the eye by front, centre and side seam balance lines; yet they are mainly founded on the same primitive idea, varied only in the slant of the seat line; when the variation grows outrageous, the backpart is frequently thrown out correspondingly at the bottom of the side seam with the sweep of a scimitar, and a shape is arrived at that fits nothing human, compelling the fronts to become an exhibition of creases.

Had we any practical method of measuring the angle from the instep to the fork allowing for the bend of knee and the lobe of the seat, we should only have to bring the waist to measure, and all our difficulties would be solved; but as it is, this is a matter of experience and judgment; and theoretical agreement seems about as impossible as practical divergence.

We have given two drafts; the first is somewhat novel and is an attempt to govern each portion of the garment by its measure on the form;—Bottom, Seat, and Waist. It is more self varying than usual and produces for all shapes a graceful and easy fit.

The second is one of the best practical methods which we know of, founded on generally received ideas, corrected by the light of our experience. Theoretical disputants have grown grey, and have left the question of "open and close cut" still unsolved; yet the mystery lies within a very narrow compass. "How much shall the angle be opened?"

As the angle of the leg seam is opened the side seam is shortened; as the angle of the leg seam is closed the side seam is lengthened; when the side seam is short, horizontal creases will appear on the top side from fork to knee, too much cloth is apparent up and down the leg, but a smooth back part is given, easy for riding or to sit down in; but otherwise full of fatal objections; when the side seam is long there will be tightness at knee when the leg is in motion, sitting down or going up stairs the constraint becomes annoying; a too crooked seat line will cause the goods to bag at the seat and the fork will look too full; too straight a seat line will also cause want of ease in sitting or stooping and the pantaloons will bulge at the knee.

We have endeavored to steer mid-channel between the rocks.

Other faults than those spoken of are mainly owing to want of unison in the lines of front and back parts, or to bad making up.

## DIAGRAMS 20-21. PANTALOONS.

MEASURES  $\left\{ \begin{array}{l} \text{Outside seam, } 41\frac{1}{2}; \\ \text{Inseam, } 32; \\ \text{Waist, } 31; \end{array} \right. \left\{ \begin{array}{l} \text{Seat, } 36; \\ \text{Knee, } 17; \\ \text{Bottom, } 17. \end{array} \right.$

DRAFT PRODUCED BY THE MEASURES.

### DIAGRAM 20. FRONT PART.

**D**RAW line A; mark off inseam 32, outside  $41\frac{1}{2}$ ; and square out at bottom about 4 inches; Mark off on this line  $\frac{1}{6}$  of entire bottom, (17 on 6ths); From this point sweep by length of inseam at B across for crotch, and by outside seam at C for waist;

From B on crotch sweep, mark off  $\frac{1}{2}$  of waist on thirds; also,  $\frac{1}{2}$  seat on halves, less  $\frac{1}{4}$  inch; Mark this point by \*;

From \* mark off also  $\frac{1}{12}$ —and  $\frac{1}{8}$  of seat at D (18 on 12ths and 18 on 8ths); The crotch point is at the  $\frac{1}{8}$ ;

At  $\frac{1}{2}$  lay angle of square, one arm touching at B, and square down by the other arm at E; From D to E 32; Knee is 14 inches down from D;

Square across by line E;

Form inseam from D, reducing at knee  $\frac{1}{4}$  inch, as illustrated;

From the  $\frac{1}{6}$  at bottom through  $\frac{1}{8}$  on crotch sweep, draw line to sweep of waist at O;

From O to top of fly  $\frac{1}{6}$  of waist ( $15\frac{1}{2}$  on 6ths); Draw line to \* and shape fork, as illustrated; undress side as per dotted lines; Make waist  $\frac{1}{4}$  inch less than  $\frac{1}{2}$  of  $\frac{1}{2}$  waist, ( $15\frac{1}{2}$ ) from top of fly;

Form top of side seam, giving the hip a gentle curve;

From E, the bottom is  $7\frac{1}{4}$  inches;

Form side seam, dropping  $\frac{1}{2}$  inch; Shrinking line is at  $\frac{1}{6}$  of bottom;

Hollow instep and cut out front part.

### DIAGRAM 21. BACK PART.

Place front part in position and extend sweeps at D B C;

Mark out from D  $\frac{1}{3}$  of seat (18 on 12ths), which gives crotch point of back part; Rise  $\frac{1}{6}$  of seat at O for top of waist;

From O  $\frac{1}{4}$  waist and 1 inch— $8\frac{3}{4}$  inches gives top of side seam on back part; From this point make waist to measure allowing for seams and slash; From seat line at waist, draw line to undress side at crotch and shape crotch as illustrated;

From E,  $\frac{1}{2}$  of bottom,  $8\frac{1}{2}$  inches, for bottom of side seam;

Make bottom at leg seam to measure 17, allowing  $\frac{3}{4}$  for seams,  $17\frac{3}{4}$  inches;

Form inseam, giving 1 inch at knee; Allow for seams and make knee at side seam to measure;

From \* on crotch sweep, measure front part to side seam. Lay this measure where crotch curve meets seat line and measure to B  $\frac{1}{2}$  of seat 18—add  $1\frac{1}{2}$  or 2 inches for making up as desired, and finish draft as illustrated. Measure from fork and make notch of back at knee same length as that of front part; from knee, measure to bottom, allowing  $\frac{1}{4}$  inch on back part.

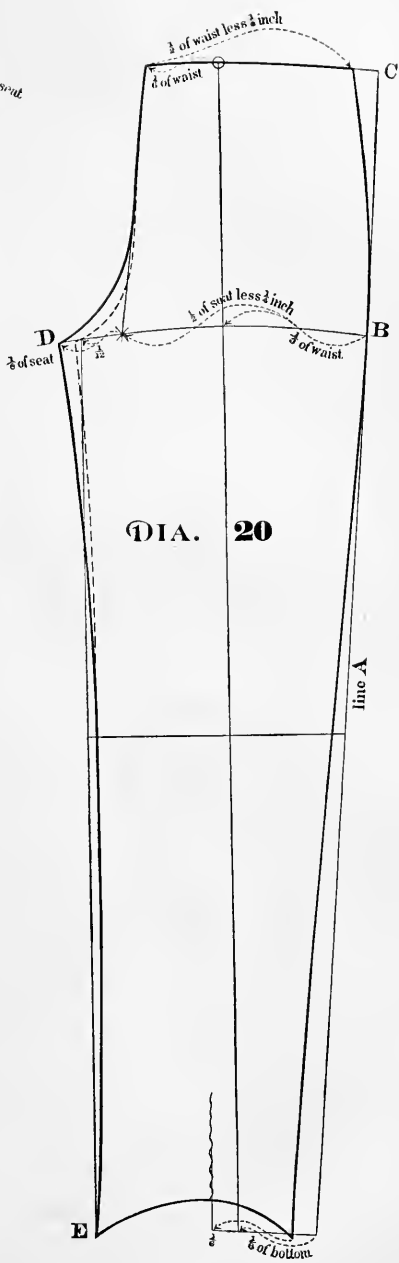
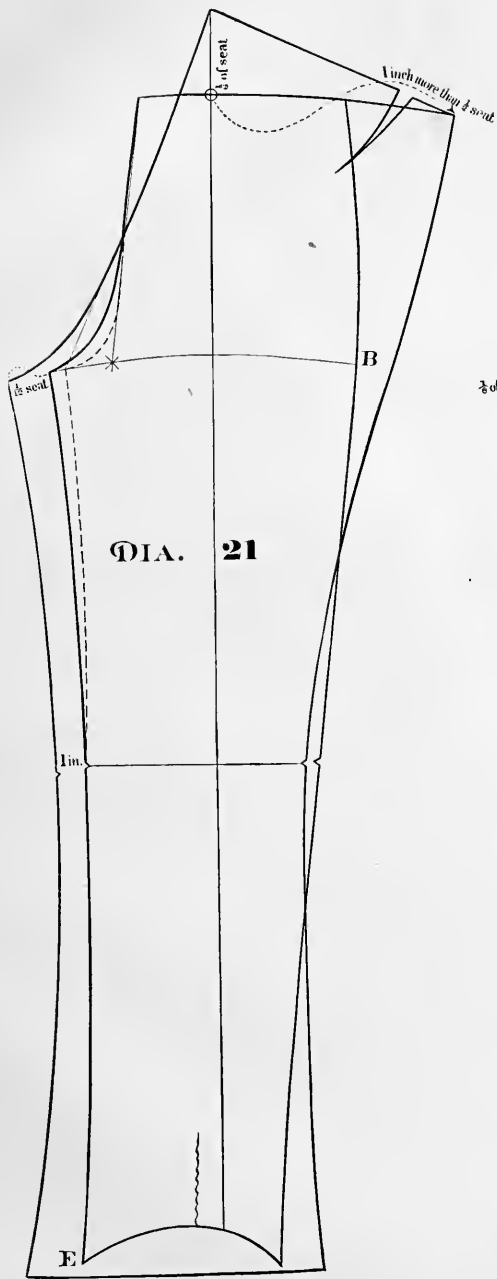

## DIAGRAMS 22-23. PANTALOONS.

### SECOND DRAFT.

MEASURES.	{	Outside seam	40	{	Waist	32
		Inseam	$30\frac{1}{2}$		Knee	16
		Seat	36		Bottom	16

DRAFT PRODUCED BY THE MEASURES.

### DIAGRAM 22. FRONT PART.

**D**RAW line A—square out at C ;  
 Mark off inseam  $30\frac{1}{2}$  at D—outside seam 40 at E—square each across ;  
 On line D mark off  $\frac{1}{4}$  seat (18 on fourths) also  $\frac{1}{2}$  (18 on halves) ;  
 Square up and down for line B ;  
 Make bottom width desired, say 7 inches ;  
 \* is the centre of bottom—from  $\frac{1}{4}$  of seat to \* at bottom draw centre line—  
 sweep from \* by inseam length on line B at crotch ; and on sweep make crotch point  
 $\frac{1}{8}$  of seat (18 on 8ths) ;  
 Shape fork as illustrated ;  
 Undress side as per dotted lines ;  
 Knee is at  $13\frac{1}{4}$  from crotch ; square across by line B— $\frac{3}{4}$  inch from centre line  
 toward inseam make \* and form knee equal on each side of \* ;  
 Form inseam as illustrated ;  
 Shrinking line is at  $2\frac{3}{4}$  from side seam ;  
 Cut out fore part.

### DIAGRAM 23. BACKPART.

Place front part in position—extend lines at bottom and knee—also at sweep of  
 crotch—crotch of back part is at  $\frac{1}{12}$  of seat (18 on 12ths) ;  
 Knee of back part is  $\frac{3}{4}$  of an inch out at leg seam ; make knee to measure  
 allowing for seams ; bottom at equal distance from \* allowing for seams ;  
 Form inseam ;  
 On line D on front part square up from side seam on 12ths as illustrated ;  
 From where this line cuts waist line, measure back  $\frac{1}{4}$  of seat (18 on 4ths)  
 for top of side seam of back part ;  
 Make waist to measure allowing for seams and slashes—draw seat line to  $\frac{1}{2}$  of  
 crotch on front part—shape crotch and seat seam as illustrated ;  
 Measure across for size of seat allowing  $1\frac{1}{2}$  or 2 inches as desired for making up ;  
 Form side seam—measure for notch of hind part, equal to notch on front at  
 knee—from notches at knee measure to bottom allowing  $\frac{1}{4}$  more on back part and  
 finish draft as illustrated.



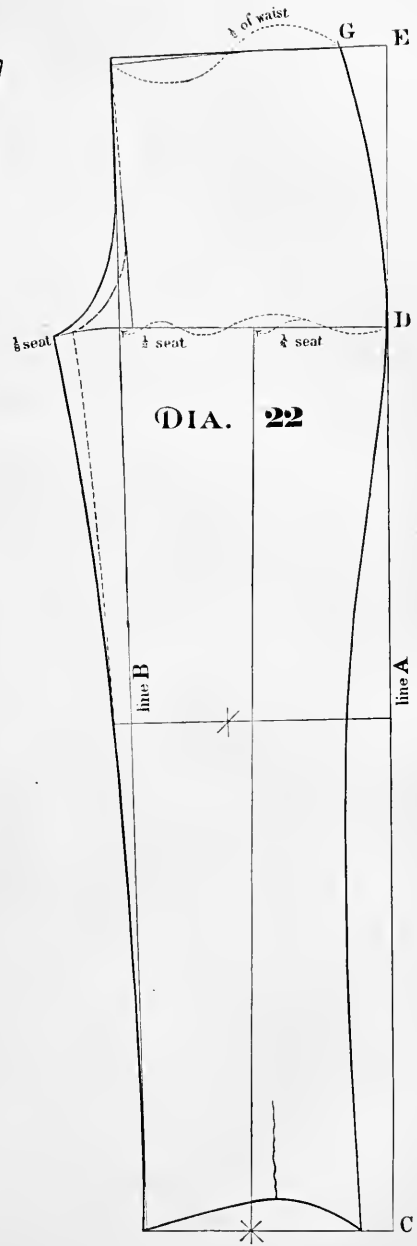
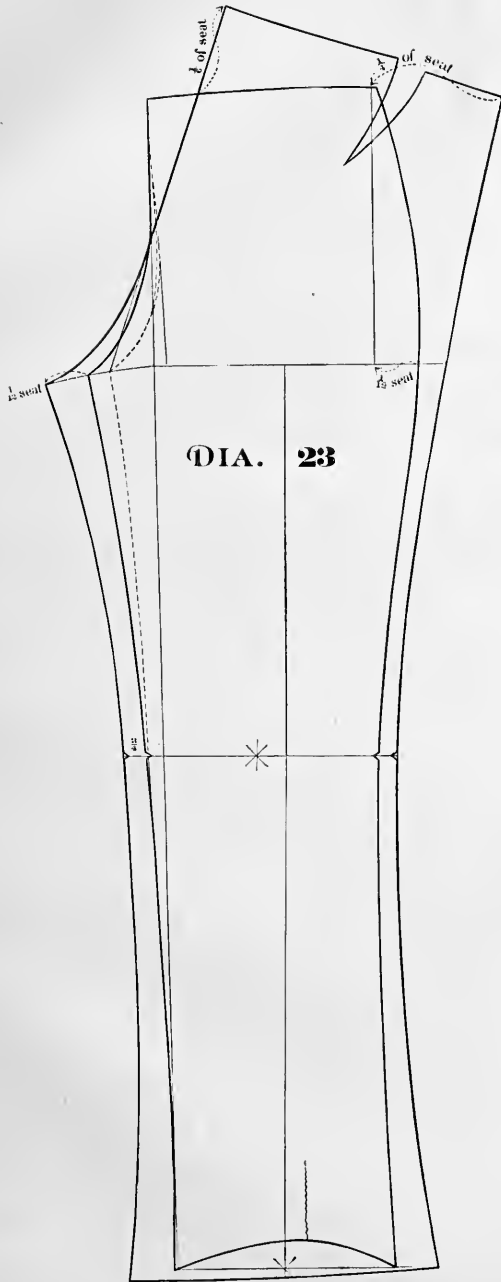

---

---

PART II.

---

---

---

## THE NEW "STANDARD" SCALE.

---

THIS Scale is graduated on the laws of growth as found in the normal American figure, and will produce a set of Patterns for the various Breast sizes agreeing with the Upper shoulder and Blade measures, (with due allowances for making up) as found opposite to the Breast size on the Table of Proportion accompanying the Scale. This method gives the Cutter this advantage, in abnormal figures, that by taking the size of the shoulder on the Customer he can look up that measure in the table and select the pattern that will give the necessary size of shoulder, and by simply correcting the breast size, will get a good fitting pattern and save time.

It has another advantage, also, that of simplicity. The letter on the Scale answers to the letter on the Diagram; A on the scale is A on the Diagram. C on the scale is C on the Diagram, and so throughout: thus avoiding the confusion incident to such instructions as those given generally:—"place S on the scale at 4 and mark W, or place B at D and mark O at H. Add A."

Widths on the figure are widths on the Scale; depths on the figure are depths on the Scale, and the Scale is so arranged that the two cannot be confounded. The widths are on the top edge and correspond to the same letters on the widths of the illustrative diagrams. The depths are on the bottom edge of the Scale, and correspond to the same letters as the depths on the Diagram. Graduated Scales are generally incorrect, the principle being but badly understood; as introduced by the elder Compaing, it was a mathematical division only and produced a 24 or a 48, according to mathematical progression. But this is not what the human figure requires; and, moreover, those divisions were based on measurements as found in Greek sculpture, on ideal figures; not on the measurements of the living figure of the time. Having an Apollo to fit of 38 chest it was perfect; as it was also, were the figure increased to 83, all would be in mathematical proportion, and if this colossal figure so fitted, were placed at an elevation that the distance would diminish it to 38, the symmetry would command admiration; but the living human figure does not grow in height as it expands in breast measure. The law of growth is also different in Boyhood from that of Manhood, and after reaching 40 chest the change is still more emphatically marked; a Scale, therefore, to be of practical use to the Cutter, must meet these conditions of change exactly in the ratio in which they occur.

Were the human figure a mathematical one, no problem would be easier of solution; but its beauty, like the difficulty of covering it, is of another order—it is neither spherical nor conical; it is simply and inherently irregular; it is an ideal humanity that answers to mathematical proportion, and certainly has not been seen on the earth since the palmy days of Greece in the time of Pericles. What we know of that time teaches us to look upon the masterpieces of art that have come down to us as made up of ideal combination, and not as realistic copies. Greek statuary, though a study for the artist everywhere, gives no table of proportion on which we can build a basis for present Works in Cutting. *Our tables must be gathered from the measure book—the real not the ideal.*

Moreover, in clothing a breathing and moving figure, we have to do and avoid doing many things easy of accomplishment were we making close fitting shrouds for the dead. Under the very best of circumstances we measure a surface in one direction, and have to apply the measure in another; and the "Science and Art" involved here is that of allowance found only by experience and *mainly incapable alike of logical and mathematical explanation.* Approximation is all that we can affirm—absolute Scientific accuracy is out of the question, and happily, is not required to insure success.



## KEY to "STANDARD" SCALE.

**A** Depth of shoulder seam on back.

**B**  $\frac{1}{2}$  of Scye depth.

**C** Scye Depth.

**D** Width of top of back.

**E** Point to square shoulders from.

**F** Front of Scye.

**S** Size of breast  $\left\{ \begin{array}{l} \text{End of Scale from } \\ \text{F on Draft.} \end{array} \right.$

**W** Width of back.

\* Depth of Shoulder on forepart.

The **Scale** will produce a Draft corresponding with the **Shoulder** and **Blade** measures placed opposite to the **Breast** size, with the necessary allowances.

**Breast, Shoulder** and **Blade** measures are taken **over** the Vest.

**Shoulder** and **Blade** measures as usually found to the corresponding **Breast** measure.

## TABLE OF PROPORTION.

BREAST	SHOULDER	BLADE	BREAST	SHOULDER	BLADE	BREAST	SHOULDER	BLADE
<b>25</b>	18 $\frac{1}{4}$	15 $\frac{1}{2}$	<b>33</b>	24 $\frac{1}{4}$	20 $\frac{1}{2}$	<b>41</b>	29 $\frac{3}{4}$	25 $\frac{3}{4}$
<b>26</b>	19	16	<b>34</b>	25	21 $\frac{1}{4}$	<b>42</b>	30 $\frac{1}{4}$	26
<b>27</b>	19 $\frac{3}{4}$	16 $\frac{1}{4}$	<b>35</b>	25 $\frac{1}{2}$	21 $\frac{3}{4}$	<b>43</b>	30 $\frac{1}{2}$	26 $\frac{1}{4}$
<b>28</b>	20 $\frac{1}{2}$	17	<b>36</b>	26 $\frac{1}{4}$	22 $\frac{1}{2}$	<b>44</b>	30 $\frac{3}{4}$	26 $\frac{1}{2}$
<b>29</b>	21 $\frac{1}{4}$	17 $\frac{3}{4}$	<b>37</b>	27	23 $\frac{1}{4}$	<b>45</b>	31	26 $\frac{3}{4}$
<b>30</b>	22	18 $\frac{1}{2}$	<b>38</b>	27 $\frac{3}{4}$	24	<b>46</b>	31 $\frac{1}{4}$	27
<b>31</b>	22 $\frac{3}{4}$	19 $\frac{1}{4}$	<b>39</b>	28 $\frac{1}{2}$	24 $\frac{3}{4}$	<b>47</b>	31 $\frac{1}{2}$	27 $\frac{1}{4}$
<b>32</b>	23 $\frac{1}{2}$	20	<b>40</b>	29 $\frac{1}{4}$	25 $\frac{1}{4}$	<b>48</b>	31 $\frac{3}{4}$	27 $\frac{1}{2}$

## DIAGRAM 24. S. B. SACK.

MEASURES.	$16\frac{1}{2}$	}	Breast 36	{	Sleeve $7\frac{1}{4}$
	$18\frac{1}{2}$		Waist 32		20
	30		Seat 37		31

### BY SCALE OF BREAST MEASURE.

**S**ELECT Scale of Breast measure 36.

Draw line for back seam ;

Square across as at O ;

From O to D is end of scale to D ;

Square up  $\frac{5}{8}$  of an inch for rise of neck ;

Form top of back ;

From O to A is end of scale to A ; from O to B is end of scale to B ; from O to C is end of scale to C ; from O to natural waist is  $16\frac{1}{2}$ , to fashionable waist  $18\frac{1}{2}$ , full length 30 inches ;

Square out from each point except B ;

From A to W is end of scale to W ; from C to E is end of scale to E ; from C to F is end of scale to F ; from F to S is end of scale from F to S ;

Square down at S as illustrated ; add 1 inch for button step ; sweep upward by C for front ;

Square up from E as illustrated ;

Square up from F about 3 inches for front of scye ;

\* on line E is end of scale to \* ;

Place angle of square at E, one arm touching at B, and where the other arm strikes the top line of the draft is the shoulder point ;

Form shoulder seam, dropping at scye point  $\frac{1}{2}$  inch ; form scye as illustrated ; backpitch is on 12ths from W ; form side seams taking out  $1\frac{1}{4}$  inch at natural waist ;

Top of side seams is  $\frac{1}{3}$  from line C ;

Spring is on 12ths, always at 30 inches down from O, whatever is the length of Sack ;

Hollow back as illustrated ;

Form gorge of neck raising it at front  $\frac{3}{4}$  inch ;

Sweep from shoulder point by length of side seam for length of front and finish Draft as illustrated ;

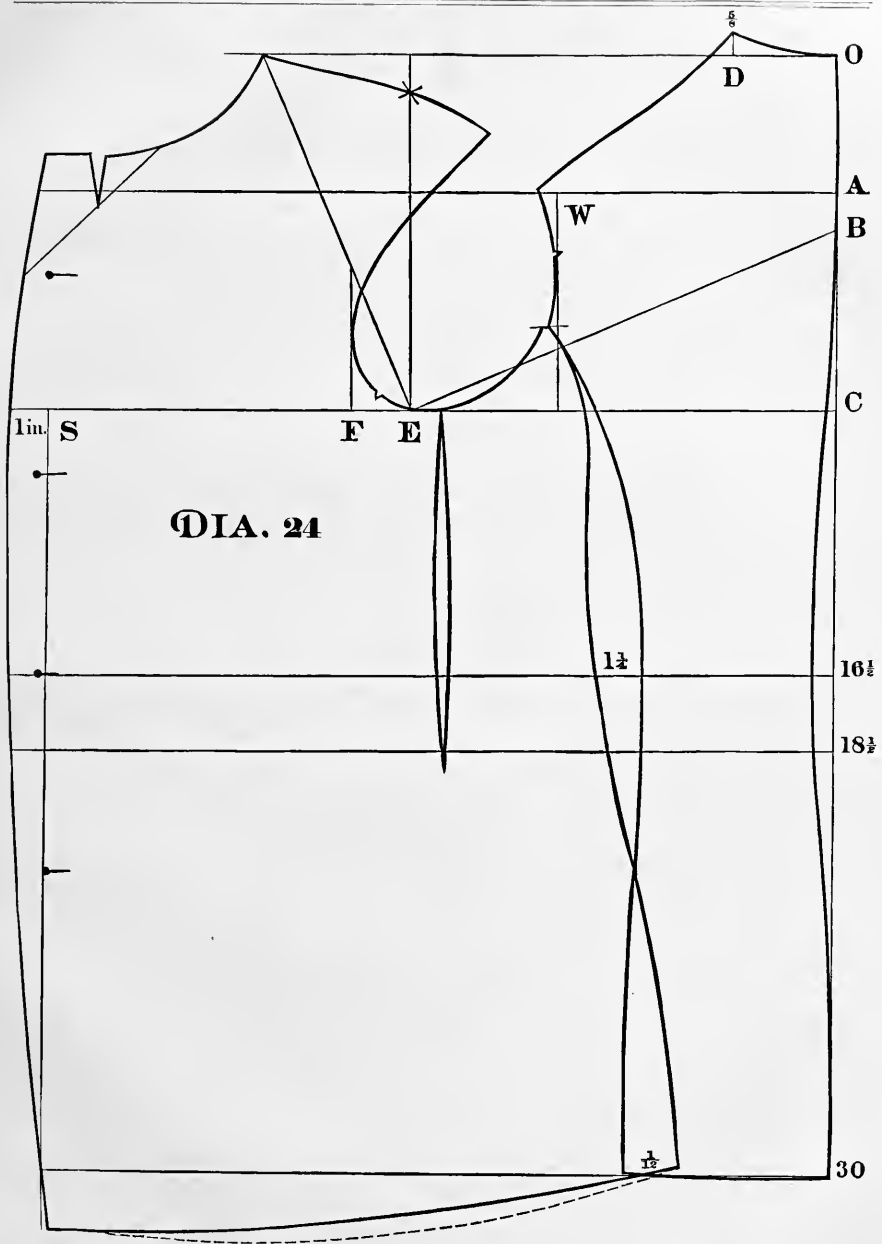

## DIAGRAM 25. D. B. SACK.

MEASURES.	$16\frac{1}{2}$ $18\frac{1}{2}$ 30	$\left. \begin{array}{c} \\ \\ \\ \end{array} \right\}$ Lengths	Breast 36 Waist 32 Seat 36	$\left\{ \begin{array}{l} \text{Sleeve. } 7\frac{1}{2} \\ 20 \\ 31 \end{array} \right.$
-----------	--	--	----------------------------------	---

### BY SCALE OF BREAST MEASURE.

**S**ELECT Scale of breast measure 36;

Draw line for back seam;

Square across as at O;

From O to D is end of scale to D;

Square up  $\frac{5}{8}$  of an inch for rise of neck; form top of back;

From O to A is end of scale to A; from O to B is end of scale to B; from O to C is end of scale to C; from O to natural waist is  $16\frac{1}{2}$ , to fashionable waist  $18\frac{1}{2}$ ; to full length 30 inches;

Square out from each point except B;

From A to W is end of scale to W; from C to E is end of scale to E; from C to F is end of scale to F; from F to S is end of scale from F to S;

Square down at S as illustrated; add  $2\frac{1}{2}$  or three inches as desired for lapel according to the prevailing style;

Sweep upward by C for front;

Square up from E as illustrated;

Square up from F about 3 inches for front of scye;

\* on line E is end of scale to \*;

Place angle of square at E, one arm touching at B, and where the other arm strikes the top line of the draft, is the shoulder point;

Form the shoulder seam, dropping at scye point  $\frac{1}{2}$  inch; form scye as illustrated; back pitch is on 12ths from W; form side seams taking out  $1\frac{1}{2}$  inch at natural waist

Top of side seams is  $\frac{1}{8}$  from line C.

Spring is on 12ths; hollow back as illustrated;

Form gorge of neck, raising it at front  $\frac{3}{4}$  inch;

Sweep from shoulder point by length of side seam for length of front;

Place buttons same distance from line squared down at S, as the edge of the corresponding buttonhole is.

Finish Draft as illustrated.



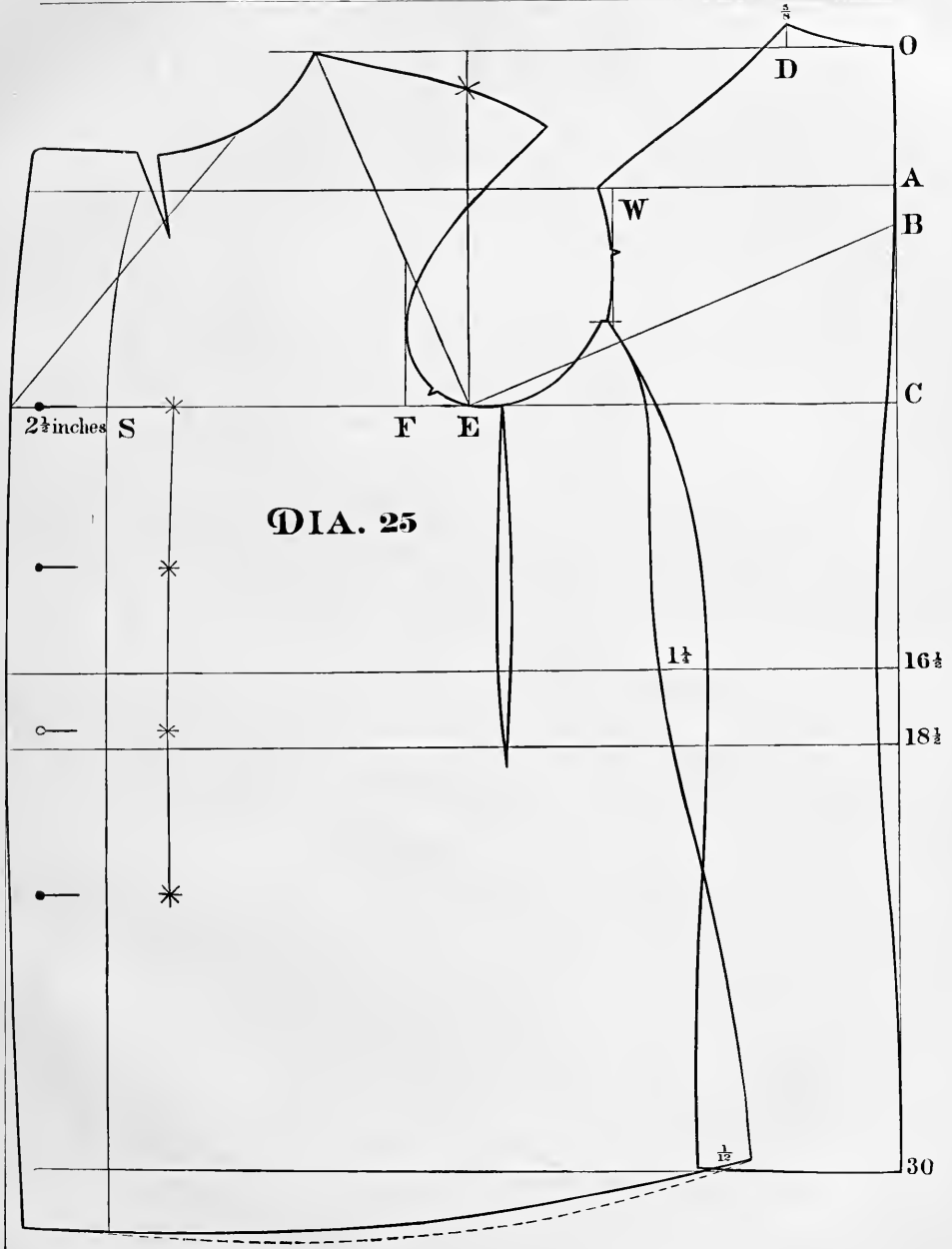

## DIAGRAM 26. S. B. OVER SACK.

MEASURES.	17½	Lengths {	Breast 38	} Sleeve. 7¾	
	19		Waist 34		20
	38		Seat 39		32

### BREAST MEASURE TAKEN OVER THE COAT.

- D**RAFT by Scale of breast measure 38 ;
- Draw line for back seam ; Square across as at O ;
- From O to D is end of scale to D ; Square up 1 inch for rise of neck ;
- Form top of back at O, raising a good seam ;
- From O to A is end of scale to A—from O to B is end of scale to B—from O to C is end of scale to C—from O to natural waist is 17½, to fashionable waist 19 full length 38 inches ;
- Square out from each point except B ;
- From A to W is end of scale to W ; Square down from W as illustrated ;
- From C to E is end of scale to E—from C to F is end of scale to F—from F to S is end of scale from F to S ;
- Square down at S as illustrated, add 2 inches more or less for button step ; square down—sweep for front by C—hollow back as illustrated, springing back seam out 1 inch at 36 inches down from O ; this prevents the drag so frequently seen at the back tack ; Square up from E—square up from F, 3 inches for front of scye ; \* on line E is end of scale to \* ;
- Place angle of square at E one arm touching at B, and where the other arm strikes top line of draft will be the shoulder point ;
- Form shoulder seam dropping at point of scye ½ inch—form scye as illustrated—top of side seams is on 12ths from line C ; Form side seams, taking out 1½ inch at natural waist, and making spring ⅙ on line 36 down from O ; Form gorge of neck taking out V as illustrated—and raise front of neck above line A, ½ inch.
- Sweep from shoulder point by length of side seam, and finish draft as illustrated, reducing at front 1¼ inch on line 36.

**Remarks.** This draft is the same in principle as that of the Undersack ; but being an Over Garment is necessarily cut more free and roomy at seat and has the spring arranged on line 36 on 6ths ; it will be seen that a good seam is added above O, and that the gorge is well filled in, so as to make a pretty straight collar seam ; the neck cut in this way, will aid in the formation of a free roll, and will allow the top edge of collar to lay close at the side of neck ; the "Jour" should be instructed that when his forepart is basted to the canvas, to press the front edge in short, so as to bring it nearly straight, *before* not *after* putting on the edge stay, pressing the fullness back into the centre of the fore-part ; the front will roll anywhere desired with an ordinary straight collar ; the back pitch being placed at ⅙ down from W, will necessitate an alteration in the sleeve draft, as shown on Diagram 13 page 29.

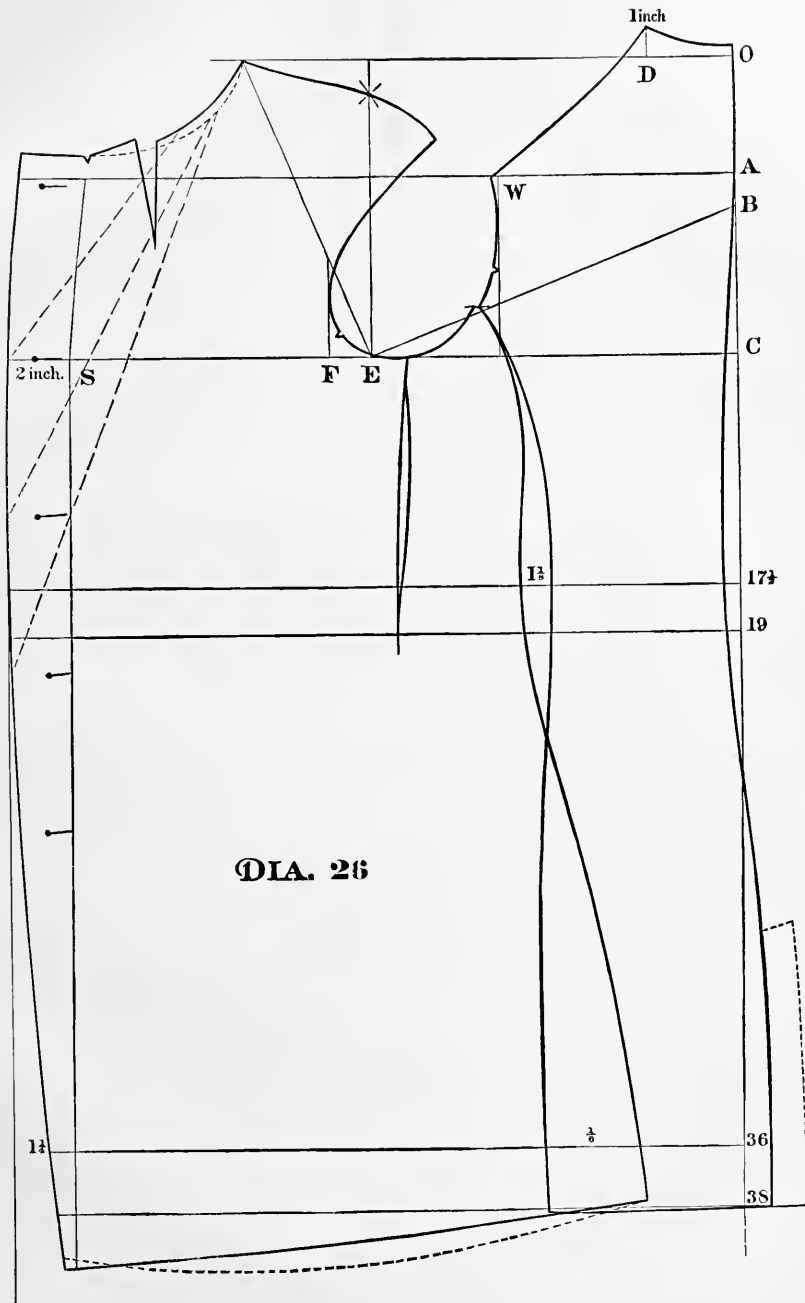

## DIAGRAM 27. D. B. OVER SACK.

$17\frac{1}{2}$ $19$ $38$	} Lengths }	} Breast 38 Waist 34 Seat 39	} Sleeve. $7\frac{3}{4}$ 20 32
---------------------------------	-------------------	---------------------------------------	---

### BREAST MEASURE TAKEN OVER THE COAT.

**D**RRAFT by Scale of breast measure 38.

Draw line for back seam;

Square across as at O;

From O to D is end of scale to D;

Square up 1 inch for rise of neck;

Raise a good seam above O and form top of back;

From O to A is end of scale to A—from O to B is end of scale to B—from O to C is end of scale to C—from O to natural waist is  $17\frac{1}{2}$ , to fashionable waist 19, full length 38 inches;

Square out from all points except B;

From A to W is end of scale to W;

Square down from W as illustrated;

From C to E is end of scale to E—from C to F is end of scale to F—from F to S is end of scale to S;

Square down at S as illustrated. Add 3 inches more or less for lapel;

Square down. Sweep up for front by C;

Hollow back as illustrated, springing back seam out 1 inch at line 36 down from O;

Square up from E—square up from F 3 inches for front of scye;

\* on line E is end of scale to.\*;

Place angle of square at E, one arm touching at B, and where the other arm strikes the top line of draft will be the shoulder point;

Form shoulder seam dropping at point of scye  $\frac{1}{2}$  inch;

Form scye as illustrated;

Top of side seams is on 12ths from line C;

Form side seams taking out  $1\frac{1}{8}$  inch at natural waist;

Back pitch is  $\frac{1}{6}$  from W.

Make spring  $\frac{1}{6}$  on line 36 inches down from O;

Form gorge of neck, taking out V as illustrated;

Raise front of neck above line A  $\frac{1}{2}$  inch;

Sweep from shoulder point by length of side seam and finish draft, reducing at front on line 36,  $1\frac{1}{4}$  inch;

Place buttons back from line squared down at S same distance as the corresponding button hole.

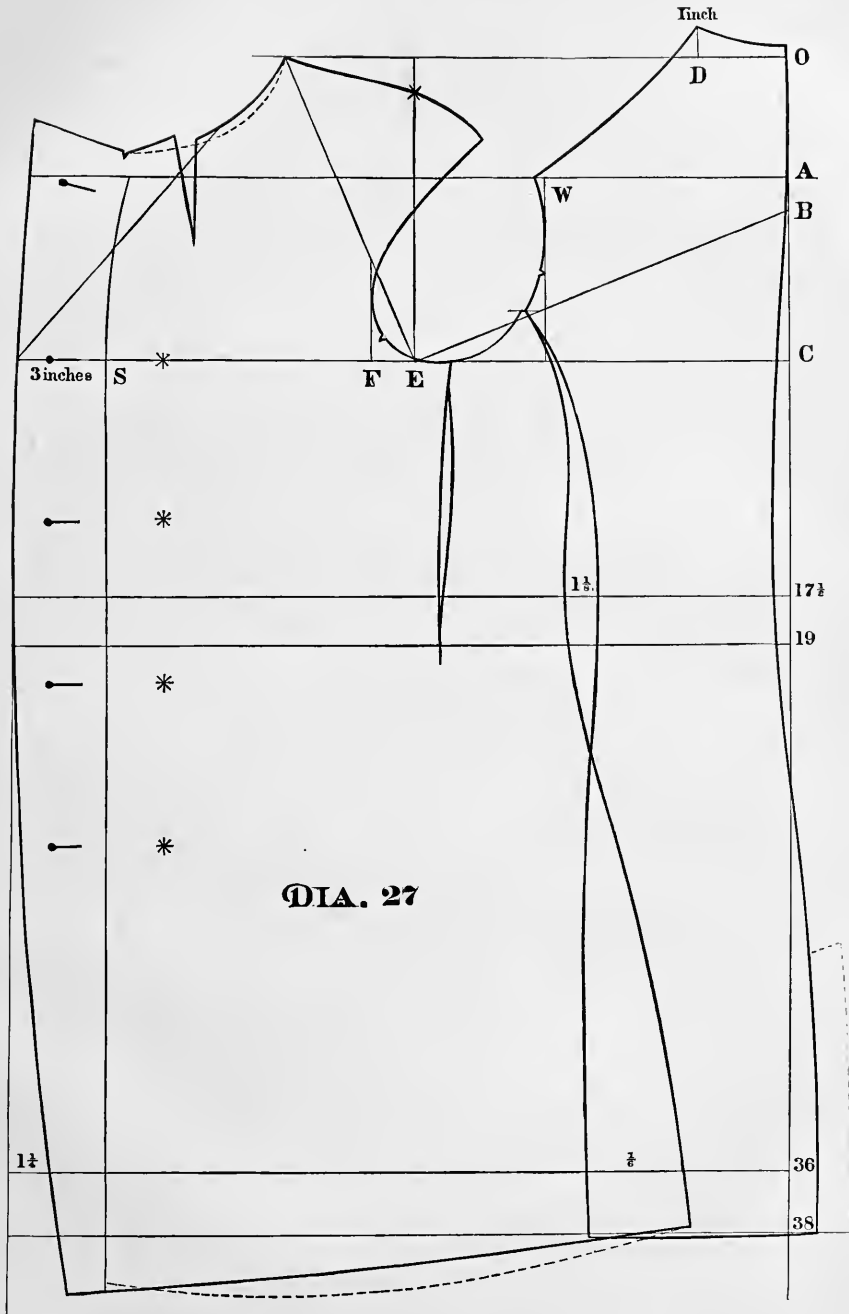

## DIAGRAM 28. S. B. 1 BUTTON CUTAWAY,

MEASURES.	$16\frac{1}{2}$ 18 33	Lengths }	Breast 36 Waist 32 Hips 35	{ Sleeve. $7\frac{1}{4}$ 20 31
-----------	-----------------------------	-----------	----------------------------------	--------------------------------------

### BY SCALE OF BREAST MEASURE.

**S**ELECT Scale of breast measure 36.

Draw line for back seam;  
 Square across as at O;  
 From O to D is end of scale to D;  
 Square up  $\frac{5}{8}$  of an inch for rise of neck; form top of back;  
 From O to A is end of scale to A; from O to B is end of scale to B; from O to C is end of scale to C; from O to natural waist is  $16\frac{1}{2}$ , to fashionable waist 18, full length 33 inches.

Square out from each point except B.

From A to W is end of scale to W; from C to E is end of scale to E; from C to F is end of scale to F; from F to S is end of scale from F to S;

Square down from W, as illustrated;

Form shoulder seam of back;

From W to top of side seam is  $2\frac{1}{4}$  inches (18 on 8ths);

Form side seams taking out at blade  $\frac{1}{2}$  inch and at natural waist  $1\frac{3}{4}$  inch;

Width of back at natural waist is  $2\frac{1}{4}$  inches;

Square down at S; add 1 inch for button step; sweep upward by C for front;

Square up from E as illustrated; square up from F about 3 inches for front of scye;

\* on line E is end of scale to \*;

Place angle of square at E, one arm touching at B and where the other arm strikes the top line of draft, is the shoulder point.

Form shoulder seam, dropping at scye point  $\frac{1}{2}$  inch; form scye as illustrated;

Back pitch is on 12ths from W; form neck gorge, raising neck at front  $\frac{3}{4}$  of an inch; hollow back as illustrated;

Form under arm seams, taking out  $\frac{1}{2}$  inch at natural waist;

Sweep for length of front waist, from 1 inch behind the shoulder point by bottom of side seam;

Draw waist seam, and finish draft as illustrated.

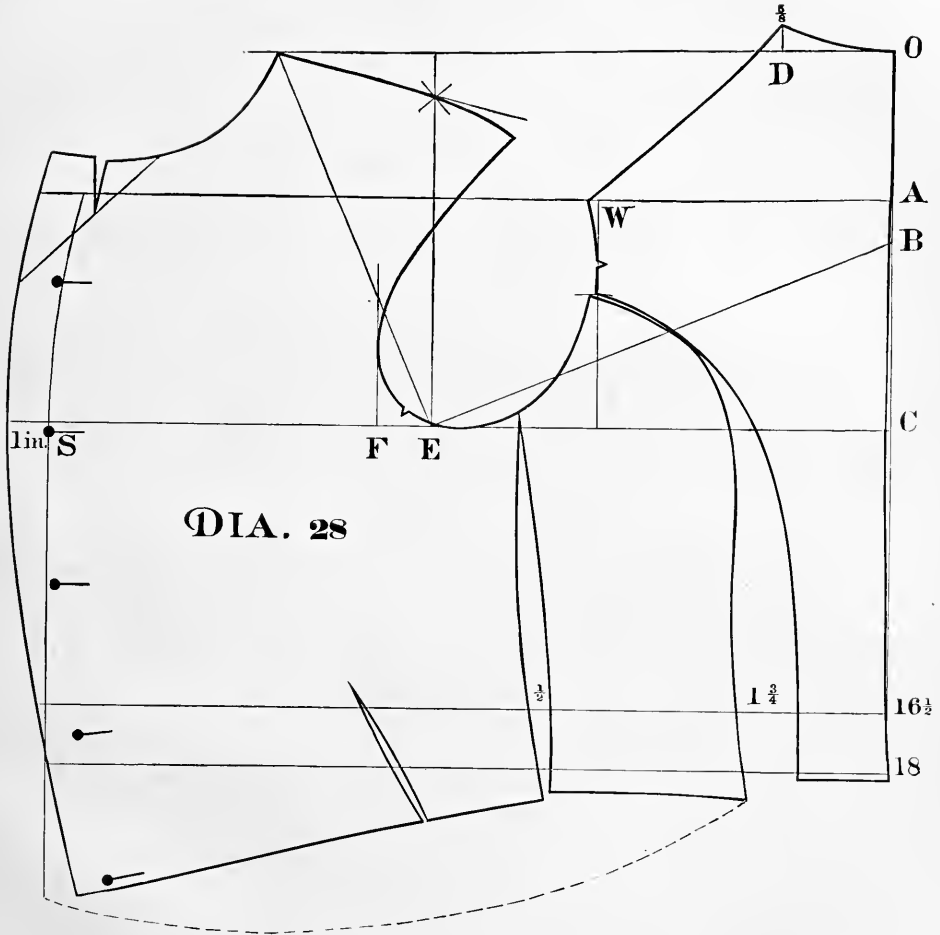

## DIAGRAM 29. S. B. 4 BUTTON CUTAWAY.

MEASURE	$16\frac{1}{2}$ $18\frac{1}{2}$ $33$	$\left. \begin{array}{l} \text{Lengths} \\ \end{array} \right\}$	Sleeve $7\frac{1}{2}, 20, 31.$	$\left\{ \begin{array}{l} \text{Breast } 36 \\ \text{Waist } 32 \\ \text{Hip } 35 \end{array} \right.$
---------	--	--	-----------------------------------	--

### BY SCALE OF BREAST MEASURE.

**S** ELECT Scale of breast measure 36.

Draw line for back seam ;  
 Square across as at O ;  
 From O to D is end of Scale to D.  
 Square up  $\frac{3}{8}$  of an inch for rise of neck ; Form top of back.  
 From O to A is end of scale to A—from O to B is end of scale to B—from O to C is end of scale to C—from O to natural waist is  $16\frac{1}{2}$ —from O to fashionable waist is  $18\frac{1}{2}$ —from O to full length is 33 inches.  
 Square out from each point except B.  
 From A to W is end of scale to W—from C to E is end of scale to E—from C to F is end of scale to F—from F to S is end of scale from F to S.  
 Square down from W as illustrated ;  
 Form shoulder seam of back ;  
 From W to top of side seam is  $2\frac{1}{4}$  inches (18 on 8ths)  
 Form side seams taking out at blade  $\frac{1}{2}$  inch and at natural waist  $1\frac{3}{4}$  inches ; width of back at natural waist is  $2\frac{1}{4}$  inches :  
 Square down at S—add 1 inch for button step—sweep upward from C for front.  
 Square up from E as illustrated—square up from F about 3 inches for guide to front of scye ; \* on line E is end of scale at E to \*  
 Place angle of square at E, one arm touching at B, and where the other arm strikes the top line of the draft is the shoulder point.  
 Form shoulder seam, dropping at scye point  $\frac{1}{2}$  of an inch—form scye as illustrated ; back pitch is on 12ths from W. Form neck gorge raising neck at front  $\frac{3}{4}$  of an inch—hollow back as illustrated ;  
 Form under arm seams taking out  $\frac{1}{2}$  of an inch at natural waist ;  
 Sweep for front of waist from 1 inch behind the shoulder point by bottom of side body—draw waist seam.  
 Cut out back and side body, place in closing position and measure across for size of breast 18 inches, add 2 inches for making up and 1 inch for step—21 inches ; this to see that the draft measures correctly—place in closing position at waist and measure along waist seam  $\frac{1}{2}$  of the hip  $17\frac{1}{2}$ , allowing for seams—make a mark and add 1 inch over—draw front line through this added inch—space off buttons and at the bottom button sweep line of front skirt as illustrated.

### DRAFT OF SKIRT.

Place in position as diagram—place angle of square at the hip of side-body and square over and down—at 6 inches across waist raise 1 inch and round the plait  $\frac{1}{2}$  an inch—finish skirt as illustrated.



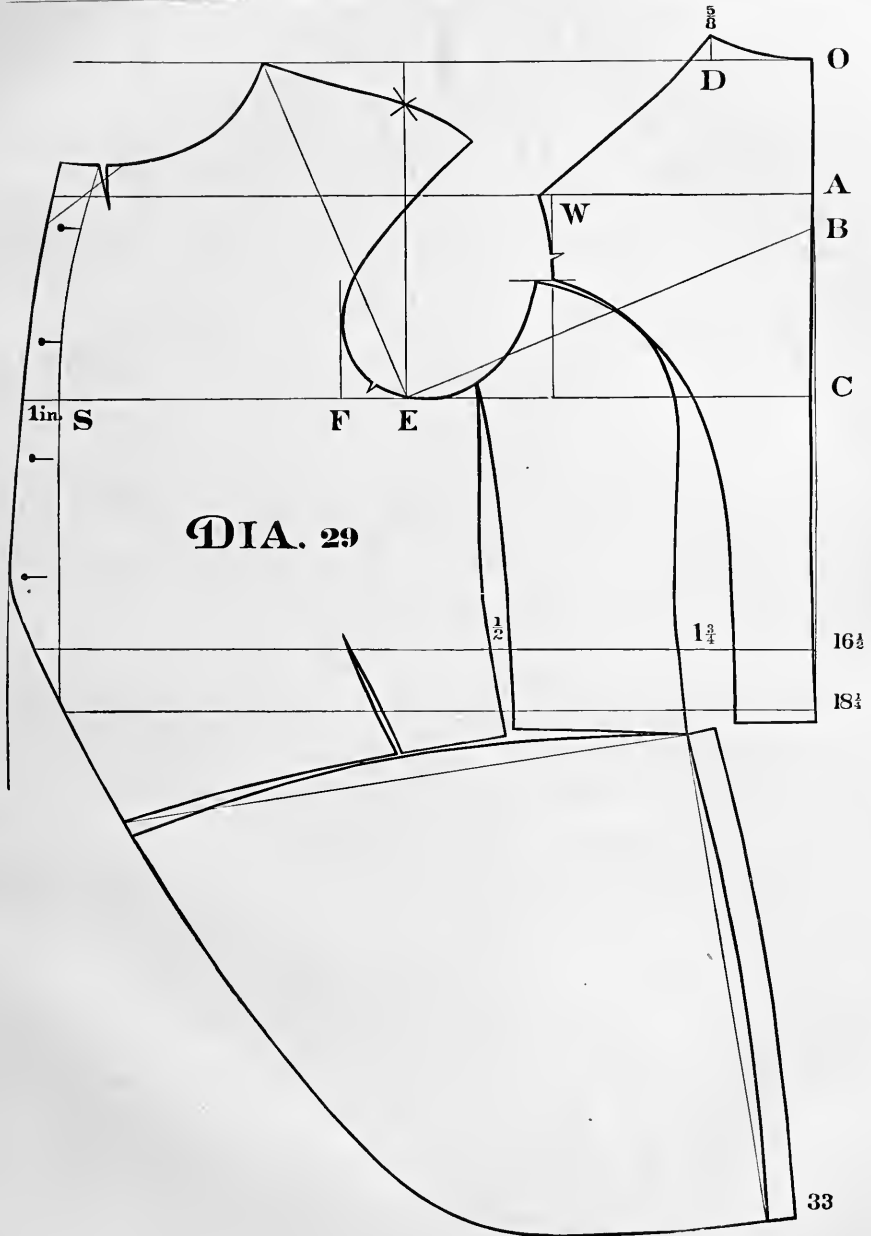

## DIAGRAM 30. D. B. FROCK.

MEASURES.	$16\frac{1}{2}$	{	Breast 36	}	Sleeve. $7\frac{1}{4}$
	$18\frac{1}{2}$		Waist 32		20
	37		Hips 35		31

### BY SCALE OF MEASURE.

**S**ELECT Scale of breast measure 36 ;

Draw line for back seam ;

Square across as at O ; From O to D is end of scale to D ;

Square up  $\frac{3}{8}$  of an inch for rise of neck ;

Form top of back ;

From O to A is end of scale to A ; From O to B is end of scale to B ; From O to C is end of scale to C ; From O to natural waist  $16\frac{1}{2}$  inches, to fashionable waist  $18\frac{1}{2}$  ;

Square out from each point except B ;

From A to W is end of scale to W ; Square down as illustrated ;

Form shoulder seam of back ; From W to top of side seams is on 8ths ( $2\frac{1}{4}$  inches) ; Width of back at natural waist is  $2\frac{1}{4}$  inches ;

Form side seams as illustrated taking out  $\frac{1}{2}$  inch at blade and  $1\frac{3}{4}$  inch at natural waist ; From C to E is end of scale to E—from C to F is end of scale to

F—From F to S is end of scale from F to S ;

Square down from S—sweep up by C for front of breast ;

Hollow back as illustrated ;

Square up from E—square up from F about 3 inches for front of scye ;

\* on line is end of scale to \*

Place angle of square at E one arm touching at B and where the other arm strikes the top line of draft is the shoulder point ;

Form shoulder seam reducing at scye point  $\frac{1}{2}$  inch , Form scye as illustrated—back pitch is on 12ths from W ; Form neck gorge raising neck at front  $\frac{3}{4}$  of an inch ; Form under arm seams taking out at natural waist  $\frac{1}{2}$  inch ;

Sweep from 1 inch behind shoulder point by length of side seam for front length, and shape waist seam as illustrated ; Cut out back and side body—place them in closing position at waist and measure across  $\frac{1}{2}$  waist 16, add  $2\frac{1}{2}$  inches for making up  $18\frac{1}{2}$ , and form lapel seam as illustrated ;

When the waist is less than the normal size, say 30 or 31, do not cut the lapel seam any different but make the difference by taking out equally at fish and side body seams ; it is preferable to reduce the waist by two fishes rather than to have a too round breast line ; if the waist is reduced at front, the coat when buttoned is apt to ride up ; moreover it makes a greater difficulty to the "Jour" to produce a good front ; the present style of lapel is annexed—cut about 2 inches at bottom and  $2\frac{1}{4}$  at top.

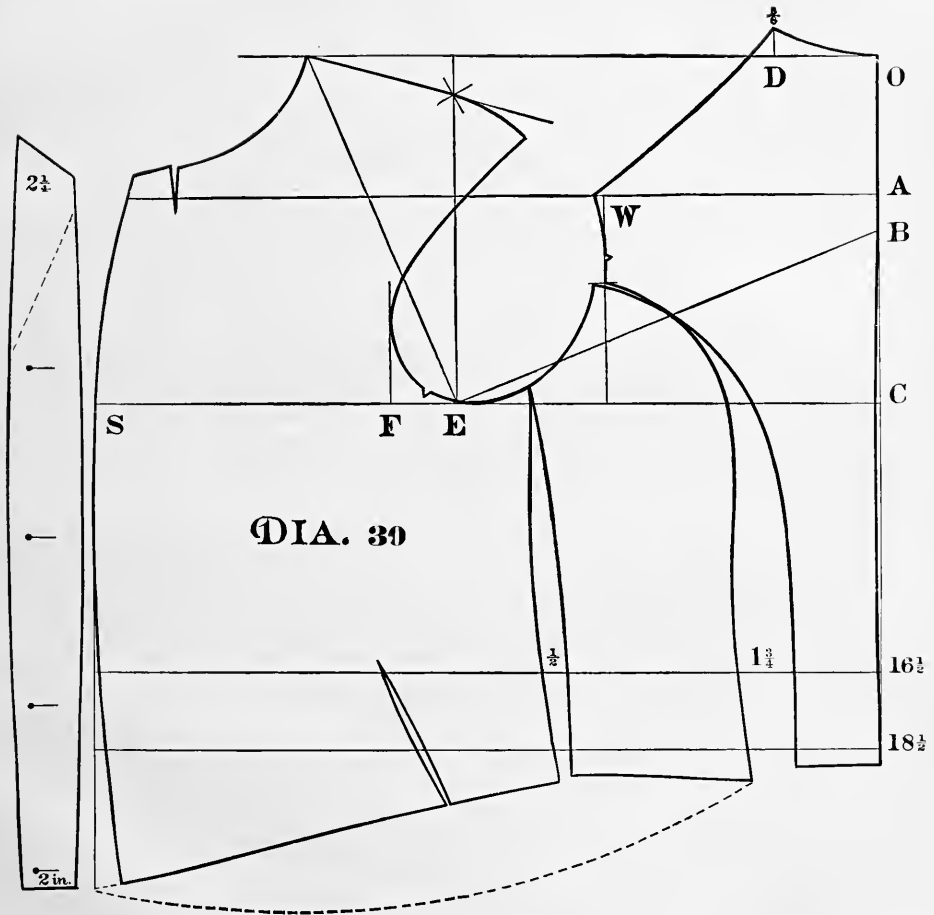

## DIAGRAM 31. S. B. VEST.

MEASURES.  $\left\{ \begin{array}{l} 10\frac{1}{2} \text{ top button.} \\ 25 \text{ Length.} \end{array} \right. \left. \begin{array}{l} 36 \text{ Breast.} \\ 32 \text{ Waist.} \end{array} \right\}$   
 Natural Waist  $16\frac{1}{2}$ .

## BY SCALE OF BREAST MEASURE.

**D**RAW back seam.

- Square across as at O;
- From O to D is end of scale to D;
- Square up  $\frac{5}{8}$  inch for rise of neck;
- Form top of back;
- From O to A is end of scale to A;
- From O to B is end of scale to B;
- From O to C is end of scale to C;
- From O to natural waist is  $16\frac{1}{2}$  inches;
- Square out from each point except B;
- From A to W is end of scale to W; Square up;
- From W to \* is end of scale to \*;
- Form shoulder seam as illustrated, widening top of back a good seam;
- From C to E is end of scale to E; from C to F is end of scale to F;
- Square up from E; square up from F, 3 inches for front of seye;
- Place angle of square at E, one arm touching at B, and where the other arm strikes the top line will be the shoulder point;
- \* on line E is end of scale to \*;
- From shoulder point draw line through this depth and form shoulder seam of fore part;
- Form seye as illustrated, clearing line at F about  $\frac{1}{2}$  of an inch;
- From C across to front of draft is  $\frac{1}{2}$  breast measure and  $2\frac{1}{2}$  inches— $20\frac{1}{2}$ ;
- Divide draft into equal parts and square down;
- Form side seams taking out one inch on each side of natural waist;
- Form back seam, reducing at top  $\frac{1}{4}$  of an inch and at natural waist  $\frac{3}{4}$  of an inch.
- Square down for front line and form front of Vest as illustrated. Allowing for width of top of back make Vest exact length and square across.
- Add 1 inch for making up and form bottom of Vest as illustrated;
- Top button to measure, allowing for width of top of back and seams;
- Form gorge as illustrated.
- Should there be more difference than 4 inches between breast and waist (36-32), take out a fish instead of a V; if the size of waist is equal to or more than breast add on  $\frac{1}{2}$  of the difference on front and  $\frac{1}{2}$  under arm. See Diagram of cor-pulent Vest.

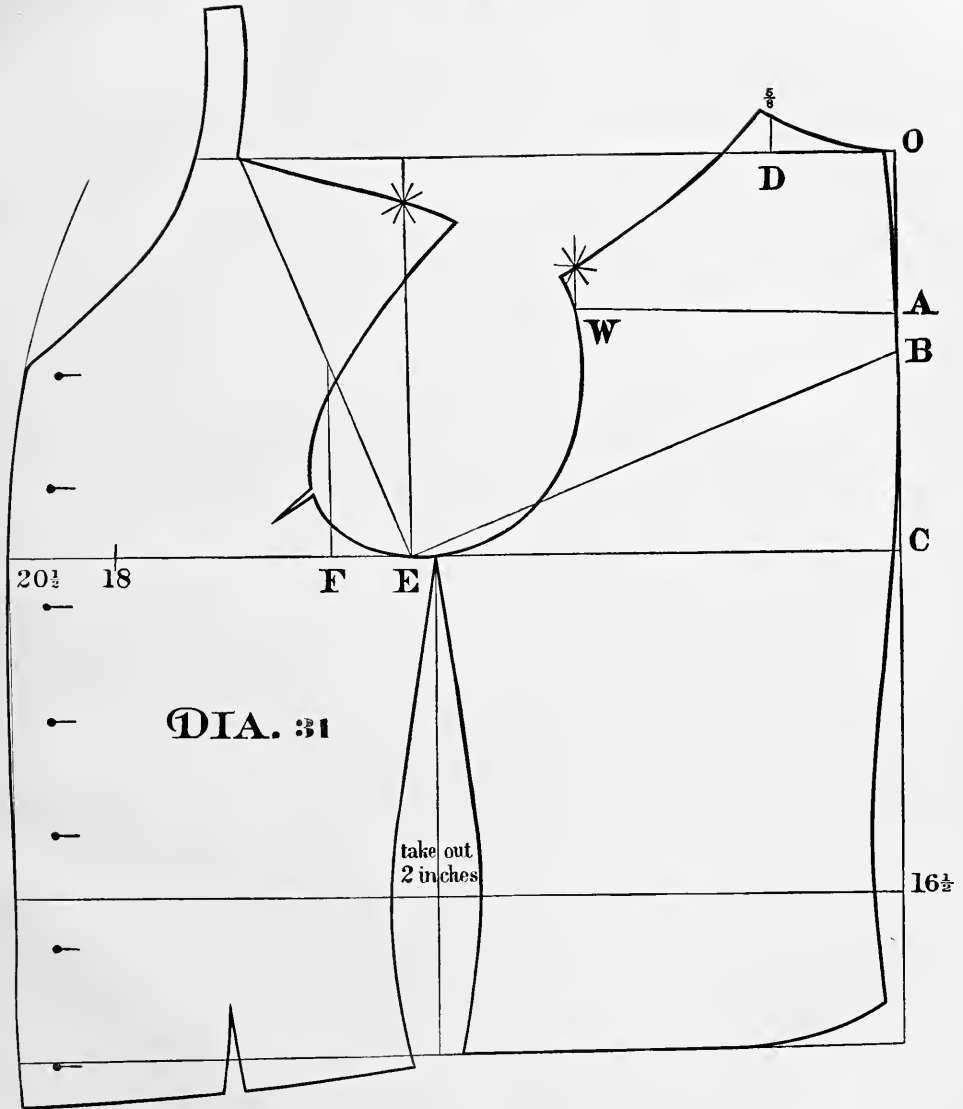

---

---

PART III.

---

---

## MISFITS.

---

MISFITS arise from the following causes:

- 1st. An incorrect measure.
- 2d. Misconception of the Form.
- 3d. Want of care in drafting.
- 4th. Bad making up.

1st.

An incorrect measure.

See pages 6-7-8 and 9.

---

2d.

Misconception of the Form.

A careful study of the methods inculcated under the headings,

Attitude or Inclination, see pages 68-72,

Use of Block Patterns, see pages 73-81,

will give the student the necessary information regarding the error which causes the misfit.

---

3d.

Want of care in drafting.

The only reason for this heading is to emphasize the necessity of *care*.

The two self-evident propositions the Cutter has to bear in mind are:

Get a correct measure.

Apply it correctly.

---

4th.

Bad Making up.

See pages 83-86.

## INCLINATION OR ATTITUDE OF THE FIGURE TO BE FITTED.

HAVING taken the required measures with the greatest care possible, we have only arrived at lengths, depths and widths from one point to another; and that, too, over a curved surface. Now, it is evident, that on laying off these measures, we do so on other lines and in other directions than on the figure measured. Every line on the body is more or less on the curve, and some of the measures in their course pass over a very irregular surface, round at one place and hollow at another; to rectify which we have to fall back on experience as to what allowance, either of increase or decrease, that experience has found to be necessary. When that has been done and we have the draft completed so far, two other things of equal, if not greater importance, remain to be considered: first, style; second, attitude or inclination of the figure—the figure may bend from the waist, blade, or top of shoulder, backward or forward. These two positions are seen in Diagram A and Diagram B; or bending either way above the blade, may take a contrary direction below. It is easy to be understood that the direction of the body has to be followed as well as the lengths and widths, or there will be a misfit. The required room may be in the draft, but it may not be in the right direction. The method which produced the draft will have to be supplemented by considerations, which shall place the given lines of length and width in the required direction.

Diagrams C and D are the drafts as produced by measure.

Diagram B is the alteration made for the stooping figure.

Diagram A is the alteration made for the over-erect figure.

The principle involved is the same in both instances: that of swinging the pattern on a pivot forward or backward, as inclined in its attitude.

The waist suppression must not be interfered with, as all necessary changes are made by the change of the position.

For the stooping figure:—Lay the back in position and swing it forward, making C a pivot to the extent that judgment dictates.

The scye has no need to be forwarded, nor has the shoulder point. The front scye is correctly located by the front of scye or short blade measure, and the greater depth of back scye has made the necessary variation in the shoulder point.

Diagram A shows the alteration to suit the over-erect figure. It will be seen that C is made a pivot, and that the back is thrown backwards in the direction of the over-erect attitude, as indicated by the dotted lines. The measure in this case, as in the stooping one, has located the scye in the right place, and the shorter back measure, in squaring for the shoulder point, has brought it farther back, giving it the necessary inclination demanded.



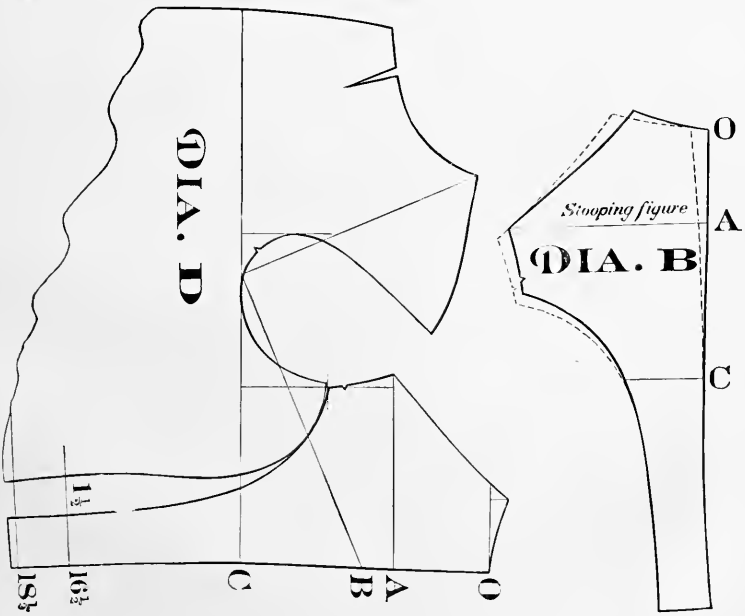
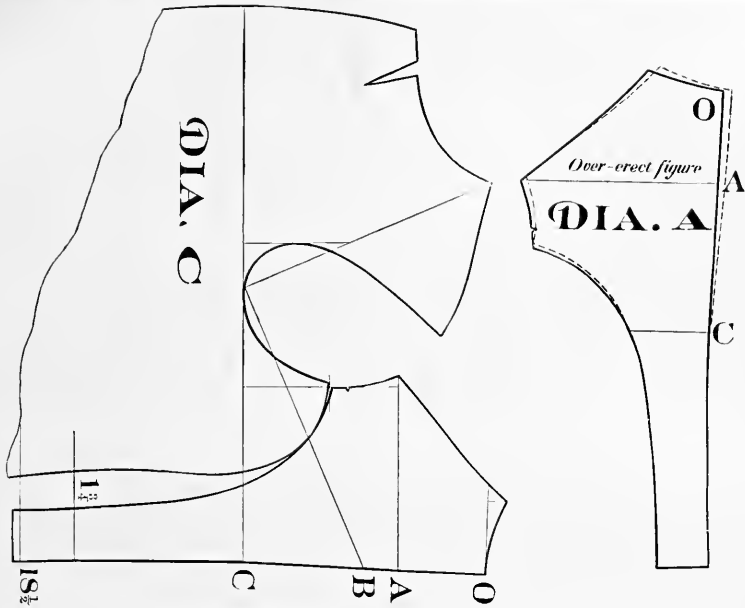

## DIAGRAM F. SWAYBACK.

---

THE stooping figure, which generally has an indentation at the natural waist of about  $\frac{1}{2}$  inch or  $\frac{3}{4}$ , sometimes takes the form of what is called the swayback; that is, from below the blade, the attitude is the same as that of the over-erect, and the indentation reaches  $1\frac{1}{2}$  or  $1\frac{3}{4}$  inch, a figure generally considered very difficult to fit; this can be accomplished, however, by following the instructions given in Diagram B, page 69. Incline the back forward for the stooping position of the shoulders and then throw out the back skirt by the waist indentation as in Diagram I, page 69, for the over-erect figure. In Diagram E the waist indentation is  $\frac{3}{4}$  of an inch only, while in Diagram F the waist indentation is  $1\frac{1}{2}$  inch as per dotted line. The top part of the back is of the same inclination in both figures.

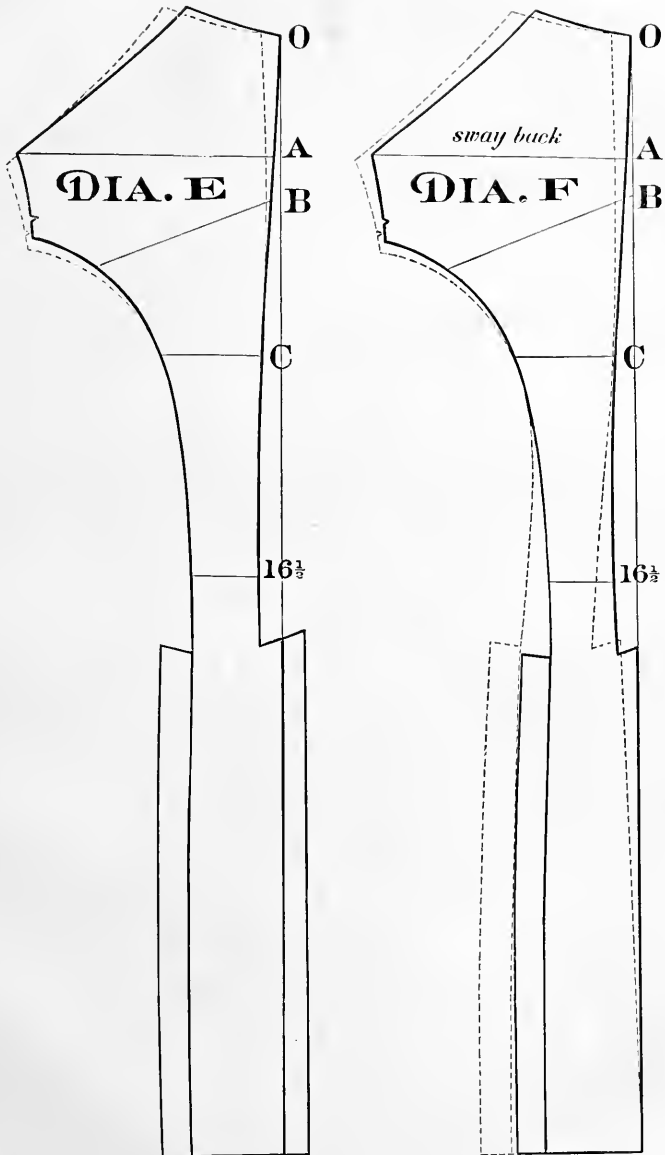

---

---

PART IV.

---

---

## USE OF BLOCK PATTERNS.

---

HAVING secured Patterns suited to the class of Trade for which they are required, it is requisite to enter on the measure book whatever differences from the normal type can be detected by the Cutter as aids to his measures. Short neck, flat hips, hollow at chest above the breast line, over-erect, head carried back, head forward, hollow between the blades, fleshy across back and around shoulders, very stooping, narrow chested, flat seat, prominent hips, high or low shoulders, prominent or flat blade, or any other peculiar conformation that the eye can detect. Note height, weight, age, as all of those remarks will be of untold advantage as the Cutter acquires experience in the use of Block Patterns.

## USE OF BLOCK PATTERNS.

### DIAGRAMS G-H. STOOPING FIGURE.

PLACE back in position and mark round it lightly;

Pivot at C and incline the back forward as indicated by dotted lines;

From O to C round the back seam slightly to give more room across the shoulders; the proper inclination being given, sufficient ease will be obtained for the round of the shoulders and a clean smoothly-fitting back will be the result; on stooping forms the back is relatively longer than the normal pattern; it is therefore necessary to add as on the diagram; if no measure has been taken add  $\frac{1}{2}$  or  $\frac{3}{4}$  of an inch, according to judgment;

Place the fore-part in position and mark round it lightly; make mark as X and use X as a pivot inclining fore part forward half as much as the back was, and mark around as per dotted lines; the scye will be forwarded thereby and the shoulder point also.

The shoulders are not necessarily larger because the figure stoops; it is simply a difference in front and back lengths; instead of the first over measure being  $12\frac{1}{2}$  it will be possibly  $11\frac{3}{4}$ , the lost  $\frac{3}{4}$  being made up from the front of scye to socket bone at O; the measure will also be more from F to C; it will be necessary to shorten the shoulder as per broken lines to preserve the same size of the shoulder.

### DIAGRAMS I-J. THE OVER-ERECT.

Place Pattern of back in position, mark round it lightly, use C as a pivot and swing the back backward as per dotted lines; this gives the attitude or inclination of the figure;

Over-erect figures are shorter from C to O than the normal one which the pattern fits, it will therefore be necessary to reduce as per broken lines on the Diagram.

### FORE-PART.

Place the fore-part in position, mark round it lightly, use \* at arm scye as a pivot, and mark around it as per dotted lines;

Reduce under arm and add at front of breast as illustrated; erect figures being smaller from C to F and larger from F across to the front of breast than the normal form which the pattern fits; this figure is also longer on the front shoulder and requires to be added to as per broken lines the same amount as taken off the back, and the reduction under the arm so as to make the shoulder measure fill. These figures accounted so difficult to fit, lose their apparent difficulty when it is considered *that the three figures measure the same size of shoulder*; the difference being that the stooping is longer on the back and shorter on the front of shoulder; the erect figure is shorter on the back and as much longer on the front shoulder.

Our illustration provides step by step for these differences.

In each case adjust the length of side seam of side body to the altered back. Diagrams G-H, I and J show the action of the principle involved step by step, but Diagrams K-L, M and N show a quicker and simpler method which arrives at the same result.

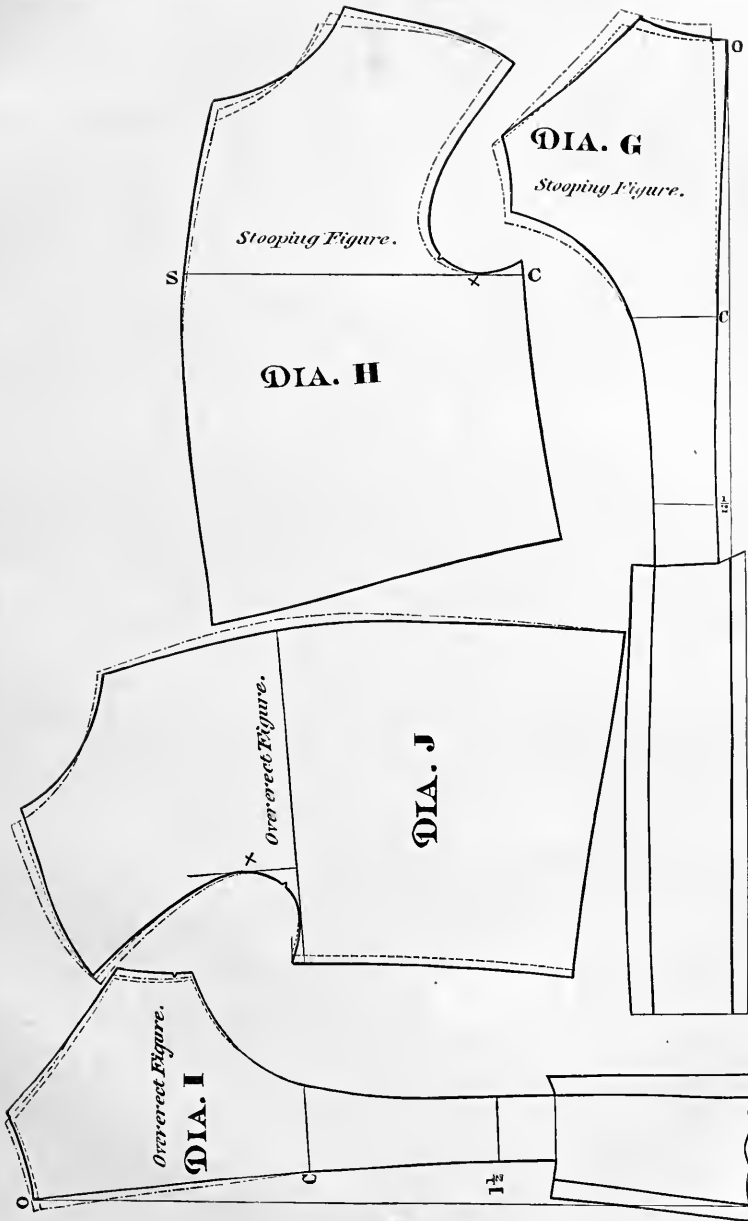

---



---

 USE OF BLOCK PATTERNS, *Continued.*

## DIAGRAMS K-L.

CUT across the back at the point where the inclination of the figure commences and open for the stooping figure what the measure calls for over and above that of the block pattern and mark around the back.

Reform the back seam so as not to have a too sudden curve.

---

 FORE PART.

Cut across the fore part on the breast line and lap one half the amount the back was opened ; mark around the pattern, then reduce a little at front of breast and cut out pattern.

Another method taught in the old school is to make a round shoulder seam on either the back or fore part or on both, and also to add to the round of blade or side seam of side body ; this puts on a longer back, raises the neck, and gives the required measures over the rounded back shoulder of the bent back of the stooping figure it is true ; but, it is unfortunately true also, that it places too much cloth on the front shoulder of fore part, making the shoulder seam longer than is required, and works in time into wrinkles, simply because cloth is given where it is not wanted ; it places too much length on the round of blade and balloons the back below *the curve of the backseam inclination* of the figure : the difficulties of the jour. are increased, and it is next to impossible for him to produce a clean, smooth, natural looking shoulder and side seam ; when on, such a coat has a heavy and clumsy look around the neck and shoulders, strongly emphasising the disproportion ; and is one more striking illustration of the danger incurred through not following the lines of the figure ;

---

 DIAGRAMS M-N. OVER ERECT,

Do just the reverse of that for the stooping figure—cut across back and *lap* the parts to bring the level at scye line on back to the required measure, and open the fore part on breast line, adding to make breast larger just what is taken off at side body under arm.

Remarks : In case the shoulder measures are larger than the block pattern will measure, take the size breast that comes to the shoulder measures required—treat the pattern as already instructed, and placing the different parts in closing position make the breast size to measure.



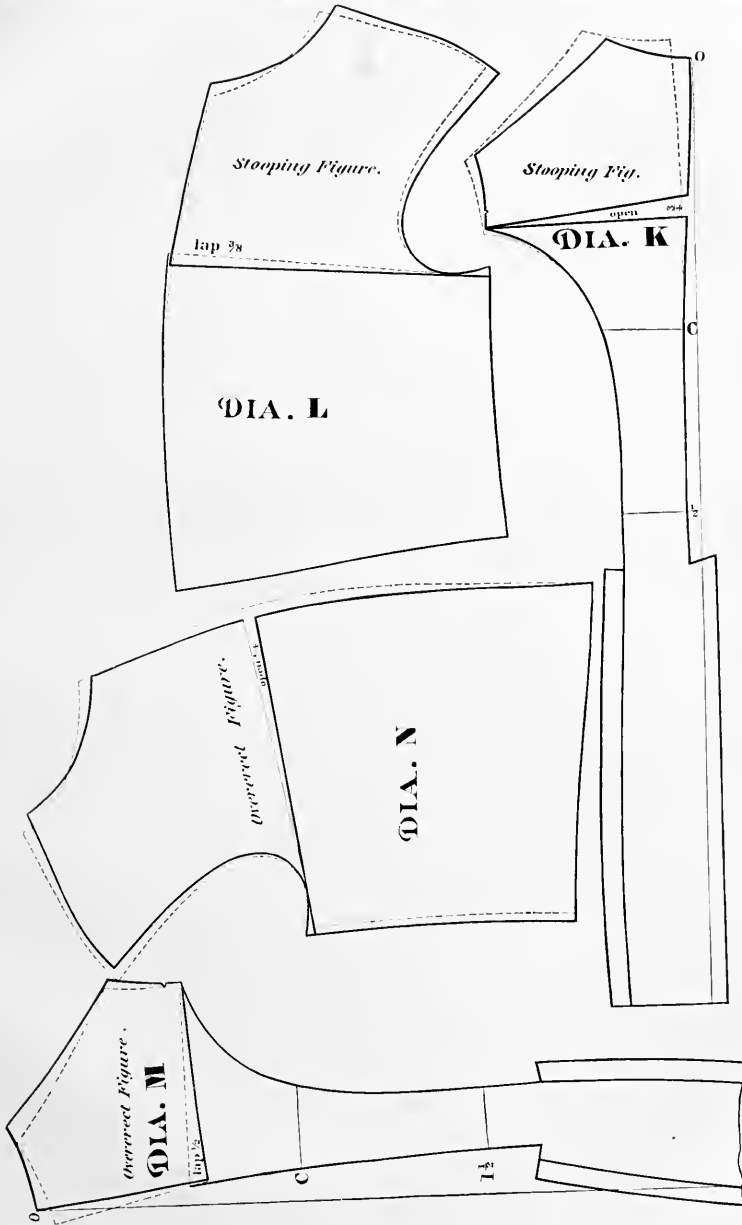

---



---

USE OF BLOCK PATTERNS, *Continued.*

DIAGRAM. SLOPING SHOULDER WITH ARM SCYE REGULAR.

THE Sloping Shoulder must not be mistaken for the long neck; the shoulder may be very low and the neck be of normal length; a low shoulder may also be accompanied by a long neck, but this is so marked a form that it can not easily be mistaken; the usual error made is not noticing whether the scye is smaller or not than is usual; in all cases of sloping shoulder it is well to take the scye measure; if the scye measure is proportionate to the size of shoulder, the dotted lines give the necessary alteration; if smaller, then Diagram P should be followed. The back remains the same in either case. See Diagram R.

---

HIGH SHOULDER.

High shouldered figures usually stand over erect, and the block pattern should be treated as per Diagram M for the over erect figure; then add on at scye point of shoulder,  $\frac{1}{2}$  or  $\frac{3}{4}$  inch, as required; the scye level measure will show if the neck needs to be lowered.

---

DIAGRAM S. SHORT NECK.

Simply reduce as per dotted lines.

---

DIAGRAM T. LONG NECK.

The Normal or Block Pattern, being too low in the neck for this figure, add on as illustrated, but it is necessary to spring the seams at neck point of shoulder in order that the Coat may go up and keep its place around the neck; many a Coat sufficiently high in the neck, but not hollow enough at side of neck, drops down in a crease under collar seam and baffles the inexperienced to discover the fault.

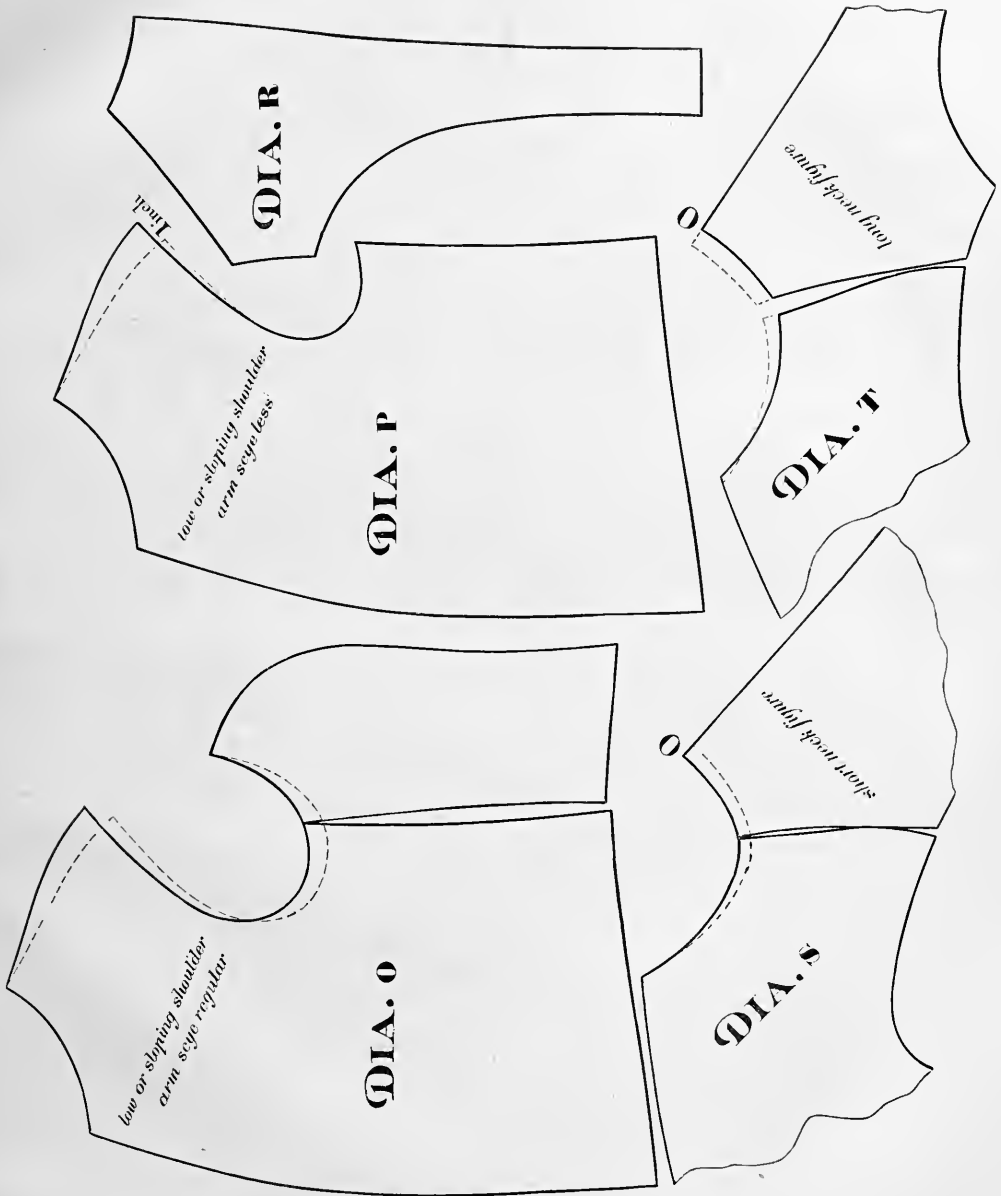

---



---

### LARGE WAISTED FIGURE.

TO alter a block pattern to suit this figure demands special attention ; the extra size is usually from the side body seams to the front ; if so, add  $\frac{1}{3}$  of the difference at the waist under the arm and  $\frac{2}{3}$  on the front ; but it sometimes happens that the form is pretty well rounded almost from the hip button ; in such a case add  $\frac{1}{2}$  of the difference under the arm at waist gradually from the top of side body and the other  $\frac{1}{2}$  in front.

This balances the figure as well as it can be on general principles ; it will be necessary to adjust the run of the bottom of the seye.

---

### SMALL WAISTS.

It is best to allow the front line at lapel seam and the side seam line to be undisturbed, and to take out the difference of measure at the side body seams and at the front slash ; if the waist is very small it is advisable to take out two slashes.

---

### DIAGRAM 32. LARGE HIPS.

This Figure has to be arranged for in a different manner than is usually taught, and frequently gives trouble to the experienced cutter ; the student is generally told to dispense with the waist measure ; to allow for seams and govern all coats that button at or near the waist, by the hip measure ; this is a mistake as it places the increase of size at the front *when it is wanted on the hips*, mainly on each side of the hip bone ; a careful study of the diagram will show the correct method ; the rest of the diagram except that the hips are  $1\frac{1}{2}$  inch larger is the same draft as Diagram 6, page 21 ; shoulder point, bottom of side seam, waist suppression are all the same ; the difference is on the hip ; the extra size required being placed there from the natural waist as spring ; the fish is slightly altered also to give the advantage of a forward spring on the waist seam, so as to ease the skirt in front ; the side body should be stretched as hard as the goods will admit of without going back again ; the waist seam of the fore part should be gradually worked out to give the hip the required size, as it is scarcely possible to give all the size in spring on the under arm seams sufficiently sudden without giving the appearance of the female hip, which must be avoided ; a judicious use of the iron will greatly aid the formation of a nice appearance around the waist of a figure with prominent hips ; the waist of the skirt should also be well shrunk in before joining to the fore part.

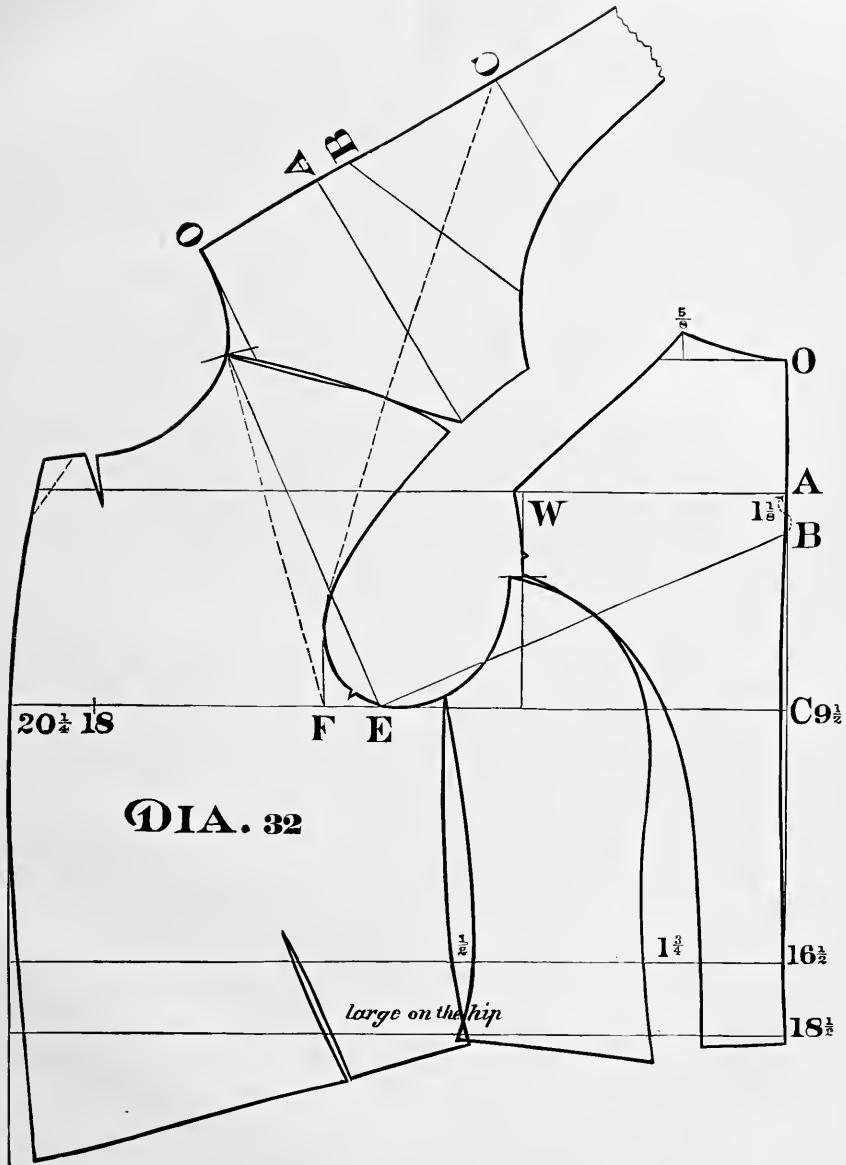



---

---

PART V.

---

---

## ON MAKING UP.

TO make this Work more complete, we propose to give some practical advice in making up, that experience has taught us is much needed.

To have a well marked success, the Cutter must know all the details of the making up; in point of fact, should be as much "at home" in the workroom as at the cutting table. He should be so much the master of his business as to be enabled to take the garment out of the hand of the "Jour" and point out what is wrong, beyond the possibility of contradiction; else he stands a poor chance of being able to distinguish where the faults lie when accidents happen. This is not a work on manners, therefore we need say no more than that faults should be kindly pointed out; *it is bad policy to offend the workman.*

Do with as little stretching as possible, and wherever edges require to be tightened have it done by the iron before the edges are stayed by tape. See that the facings are put in smoothly and of sufficient size; taking for granted that the seams have been cut with the required contour of curve, see that the line is preserved in the making up, and that the facings are always felled *exactly on the seams*, preserving the same shape. A very important thing, as regards gracefulness and fit, is comprised in putting in the facings to fit the outside; if this be properly done and *the Coat is not what it should be*, then the Cutter has a problem for consideration.

Nothing tells more against a Cutter's reputation than creases or wrinkles in his garments; not even a misfit. On the detection of a crease, whether it be across the top of the back, across the shoulder, at front of seye, across the breast, or across the top of side seam (and it is the Cutter's experience to get all of them, it becomes his business *to know the why and wherefore*; and, unless he be as conversant with the details of the making up of the garment as he is with the cutting of it; he is placed in a very unenviable position, *he is at the mercy of the "Jour."*

Many who either cannot or do not reason, place a creased shoulder on the broad back of that White Elephant in the Trade, *the shoulder point*; it is said to be too *straight* or too *crooked*, dependant upon its being more forward or more backward than just that *exact spot* which, to such minds, is the *ne plus ultra* of all that is required in a coat; entirely overlooking the fact that in the many practical systems used by our leading cutters (all other conditions being equal) that the shoulder point has a play of an inch forward and an inch backward from a central point, and in no instance getting a creased shoulder; of course, always provided the required length of strap is given.



If the shoulder is of sufficient length and in its proper position and yet creases, what is the cause? We answer, the most prolific of all causes—

### TWISTED FACINGS.

Facings should be cut about  $\frac{3}{8}$  of an inch larger around neck, shoulder seam and scye than the fore part; no more; it is usual to cut them an inch larger; the two lines on diagram 1 will show what we mean. When cut to the outside line there is too much margin given to the Jour, and if, as is generally the case in all shops except those of the best trade (and sometimes even among them), the sleeves are sewn in by machine, and that too before the facing is basted to the shoulder; it is more than probable as the Jour has then no guide as to shape that most or all of the extra

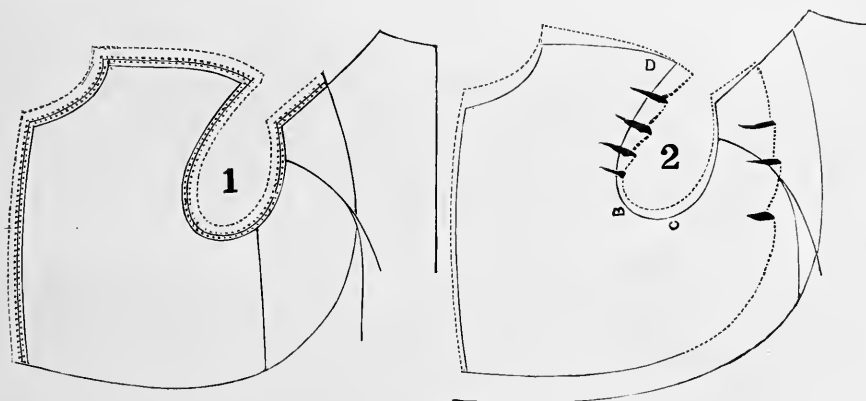

width will get pushed out at A or D see (Diagram 2), and cut off, the extra length will be basted in between D and B; the consequence is that the scye from D to B being on the bias, and the fullness of the sleeve being kept on in that distance, that this part of the scye gets stretched to the length of the facing, and being serged tightly to it, drops down with the back pad at back scye, causing wrinkles as shown in Diagrams 2 and 3 on blade, besides having the effect of making the top of side seam appear too large; too much length from B to D made in this way affects point A, as if A were cut too short, and unsightly wrinkles appear as shown in Diagram 4; *once in, never out again*; you may rip shoulder seam, hollow and stretch fore part at neck point of shoulder and gorge, put back and collar on full and lengthen shoulder point to balance the lengthened scye point, but the creases will not away—the only chance is to cut the entire facing clear across the shoulder, canvas wadding and interlining,

and baste new top of facing to the shape of shoulder, for there is the fault and this is the cure. The facing is a joint compact mass, welded together by being thickly padded, or still worse, machine sewed and *always commands the outside*; it becomes the same thing as if the Cutter had cut the shoulder  $\frac{3}{4}$  of an inch too short at neck point, and as much too long at scye point; had this been done all know the shoulder must break, and it is more certain to do so now, by the facing being twisted in shape, and pulling the outside in different directions. Such defective tailoring is very apt, too, to further increase the fault by the back being put on tight in the hollow of the shoulder, which of itself would throw creases even if there were no facing. Diagram 2, will show also in the lower line a too deep interlining and wadding brought down below the round of blade and hollow of side body and side seam. Now, the outside is hollow under the arm and round over the blade, falling in at top of side seam point; as usually worked up, the interlining and its cargo being made up flat, and on the straight, drags on the blade, causing the outside to appear full, as we have before noticed (see Diagram 3), and when brought up to the shoulder and closed, having neither sufficient length nor width for the outside on the rounded parts, drags away at A, causing creases as seen on Diagram 4.

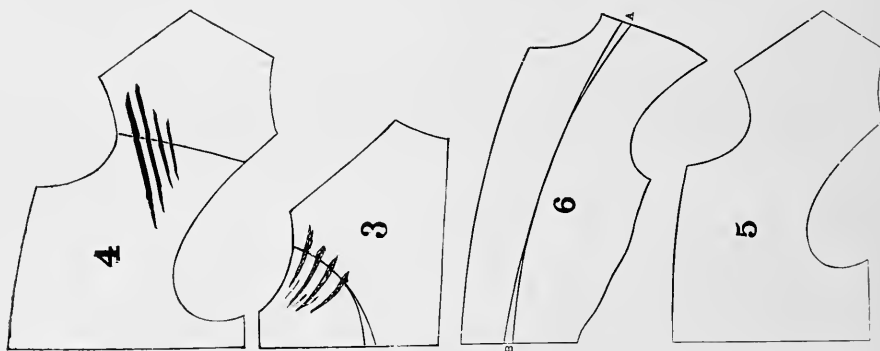

ILLUSTRATIVE DIAGRAMS 3, 4, 5 AND 6.

The facings should always be cut through at the side seam—the back pad being made apart from the side body, and stitched on the back lining independently, and fastened on side seam as it is on the shoulder seam to the exact shape of the respective seams, and *on the seams* not half or three-quarters of an inch away from them. This troublesome crease business, and it is an ever recurring one in large trades, can be easily avoided by the means we have indicated.

In speaking of twisted facings as the most prolific cause of creased shoulders we desire to impress on the mind of the reader the obvious fact that if the inside of the Coat does not fit the customer the outside cannot; if any main point of the facing fail to reach its proper position by one-half inch or by one and a half inches, that

main point of the outside to which such point of the facing is attached, is thereby located where the facing brings it, besides having the outside disfigured by the crease, fold or wrinkle into which the outside consequently doubles up.

The facing should be tight nowhere, neither in length nor width, but should fit the outside as the inside of the eggshell fits the outside; wherever possible the facing should be treated as is the outside; V for V, shrinking for shrinking, stretching for stretching; and where the facing cannot be stretched as is the outside, a V or fullness should be used to produce the same effect; the front edge is more or less shrunk in always, yet how few shrink in the facing to fit it; the consequence is that the outside is all of a blister, and the room intended to have been given over the round of the chest is destroyed and the coat tightened across the buttoning; the shape required is indicated by the cuts and the boundary lines; but what is more common in the daily experience of the Cutter than to find the same effect produced in the finished garment when he has cut V's as when he has cut fishes; often both are pressed out flat and the whole effect destroyed by the facing being put in, not only flat but tight also; the fish intended to make a shapely hollow, the V a required fullness on the round; each desired effect destroyed by defective tailoring and the garment finished as flat as the cutting-table, except where the tightened edge curls the thing inward; this is not shaping, it is simply *crippling* the outside; even when the canvas, hair-cloth and its cargo may be rightly shaped, the cloth facing and lining counteract what this was intended to produce. The simplest method known to us is to build up one part of the garment on the other—the canvas on the outside, the interlining, hair-cloth and padding successively placed one upon the other, each in its turn worked up to fit each other. The shape of the facings can be greatly helped by cutting the edges which are sewn to each other lengthwise. (See Diagram 6).

Just where the lining sews on to the inner edge of the cloth, is usually the place on the breast that the Cutter intends should be shaped to the figure, and by cuts he produces a rounded form; it will be seen that both edges are rounded in the Diagram; this gives both length and width at this part and meets the requirements of the outside and has no tendency to slide away from its proper place when finished, as is the case in some other methods intended to produce the same effect. Facings cut as per Diagram 6, prevent the formation of horizontal creases across the breast, which we have seen after a few days wear start from the top button, increasing in boldness as they traveled downward to the waist seam; when this is the case a slash lengthwise and another crosswise will show the trouble plainly; the facing freed will gape as if tired by the effort to spoil the fit. Put on the garment after the slashes have been made, that which seemed shapeless, swinging about as if it had no relation to the figure it was made for, will drop into its place hugging the breast, falling neatly into the hips and around the breast, fulfilling the best hopes of the Cutter.

Diagram 5 is offered as a Conundrum to those who still cling to the ridiculous idea that the mere position of the shoulder point is the cause of creases on the shoulder. It is intended to represent the shoulder of a Coat without a shoulder seam, the back and fore part being cut in one piece. Will any tailor out of a lunatic asylum doubt that this shoulder will crease and wrinkle if the facings are put in as we described when considering them as the cause of the trouble? Put on a short collar, twist the facings, keep the fullness of the sleeve head close to back pitch, and as far away from fore arm as is possible, and a most interesting "kill" is the result; creased shoulder, tightened scye and fullness at top of side body seam will then be apparent; but where, all this time is the shoulder point?

A Coat may be cut outrageously crooked, crooked enough to fall away from the fore arm pivot and swing off at the hip, or it may be cut outrageously straight, straight as the latest appearance of *the old thirds and fourths in its grand edition*, and yet no creases need appear on the shoulders; in the one case, the Coat may soon tear at the fore arm, and in the other, no amount of objugatory prayer will keep it from lapping at the front of scye; the Customer will complain of too much cloth, but it is simply the result of a constrained position of the shoulder—the shoulder out of its position with respect to the other parts of the garment. Slash such a Coat across from the place where the lap commences above the fore arm to the top button, and the breast will open enough to get rid of the lapping, but the Coat will hang listlessly around the hips under the arms like a flapping sail, showing plainly that a true balance is the *harmonious relationship* of the various pieces called a Coat. On paper the draughtsman can make any point his fixed point and rightly claim that it must not be disturbed, because all his other points obey its governing impulse, he may start his Coat from a given inclination or direction of the breast-line, the neck and hip can only be placed within determinable spaces; his suppression then becomes of vital consideration; he may start from some point in the neck circle and work downwards, locating every point in accordance with this one; or he may prefer the orthodox straight back seam and work from the socket bone in the usual way, locating his several points upon some theory of mutual relationship, but it is upon this idea only can he work rationally and come out right. How much do you take out at top of side body? How much do you take out between back and side body at natural waist? How much do you consider ought to be taken out under arm? Do you think, chimes in a discoverer, that anything ought to come out at side seam, top or bottom, simply a fish to fit the hollow—is not that your idea; Where do you fix your shoulder point? Who has not been asked these questions whenever a number of Cutters rally round a Coat Draft? We close this essay by saying that such questions are proof positive that the questioners have all to learn; that they are as yet totally ignorant of the first principles involved; *every point is in relation as to position with every other.*

---

---

PART VI.

---

---

---

## CREASES IN GENERAL.

---

IT is not only across the shoulders and breast that badly fitting, twisted and tight facings will produce creases. We have already pointed out that horizontal wrinkles are too apt to gather across the top of the side-body also, and that when this defect occurs it not unfrequently happens that it causes the scye to feel tight at the forearm; it sometimes chances that the creases extend from the forearm across the shoulder, making a heavy fold underneath the collar seam from one side of the neck to the other; in such an extreme case as this, the facing being much too short to reach the shoulder-point, the back lining is pulled upon to supply the deficiency, and having no more width at top of back than the back itself requires, it produces a similar effect to that caused by the back lining being too short at top; but the chief fault is that there is not sufficient room in the lining around the neck, which cripples the outside by bringing it down to that place around the neck which is of the same size in its curve as the lining; a fold or wrinkle below is the inevitable consequence; it cannot lie smoothly about the neck on a longer curve than that to which the insufficient inside has brought the outside.

Back linings are rarely put in wide enough immediately across the top of back, as the shoulder seams of the lining are felled before the collar is sewed on, and no allowance is made for the stretching of the neck gorge; true, it is customary to put a plait through the back seam; but it is also customary to securely tighten it by sewing the maker's name ticket firmly across the back plait, a piece of stout silk or lasting on the straight fastened down so as effectually to counteract any good for which the plait was intended; kept from all elasticity still further by the felling of the collar.

The attempt to correct this fault of a roll around the back neck, is made mainly on the supposition that the Coat is cut too high in the neck, or that the collar is over-stretched and put on short; in the former case the neck is lowered and the collar stretched; but the unsightly fold remains, because the lining, ten chances to one, is now tighter than before; in the latter case the collar is lengthened, but to no purpose; a V in the facing at neck gorge and more lining across the top of back is the remedy, at once simple and correct; this being attended to and the fault still in existence, the Coat is probably cut too high in the neck, and also lacks sufficient spring for the slope of neck at shoulder point of shoulder seam; this is easily discovered by opening the shoulder seam and setting the collar free at top of back; in stout figures with short thick necks, the double fault is sometimes made in cutting; cut too high in the neck, and also nipped too much at neck of shoulder seams on forepart and back; and it is sometimes, nay, often, caused by badly cut underwear and worse cut shirts making a thick roll of goods across the back at top, making it next to impossible for any outer garment to remain smoothly in its place.

## CREASES AT BACK-SCYE.

This fault in an otherwise faultless coat is frequently caused by cutting too straight a back seam for the sake of style, and is as often found in the work of high-class trades as in that of poorer ones. It is a fixed idea with the cutter, that unless the back of the figure to be fitted has a violent inclination one way or the other, bending backward or bending forward, very stooping, or over-erect, *it is a fixed idea that the back seam should be cut straight*, and the back is lengthened or shortened as if this squarely met the case; printers' ink is used in abundance; teachers of cutting affect to be knowing and talk glibly; anatomy, mathematics, and machinery are called into court to get the true level of arm scye on the back, and a point at right angles with the same at front of scye; with these relative measurements thus secured, the cutter is assured that he cannot go wrong. Alas! it so happens that he does, notwithstanding—*measurement is not attitude, length is not inclination.*

SEE DIAGRAMS 1 AND 2.

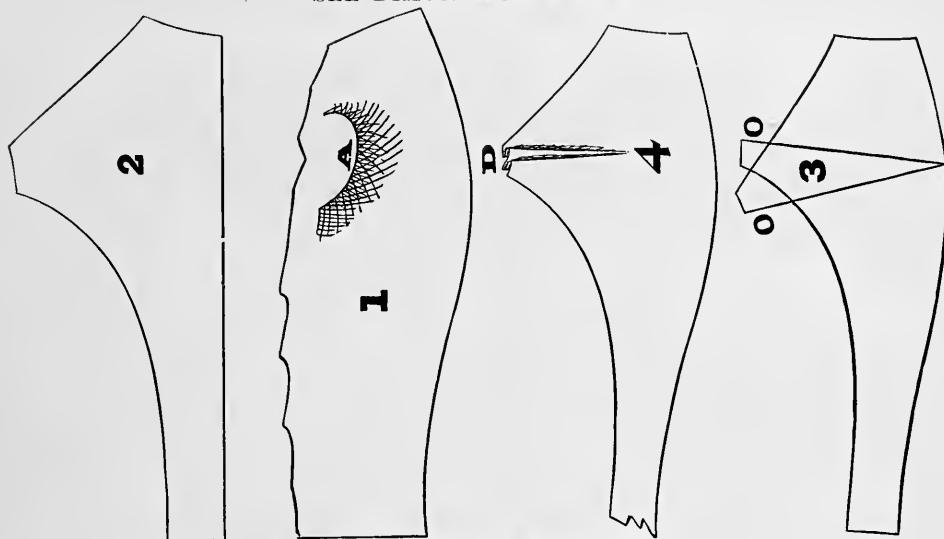

ILLUSTRATIVE DIAGRAMS 1, 2, 3 AND 4.

Diagram 1 shows the section of the normal back which is to be fitted; Diagram 2, the back cut in true orthodox fashion to fit it. Now it is self-evident that when the straight edge of the back-seam is placed on this curved inclination, there will be a superabundance of cloth to be got rid of somehow, or there will be no fit; it is as idle to expect it as it would be to think of fitting a spherical ball or a cone by joining straight lines together. A glance at Diagram 6, will show what we mean: wedges must be taken out as at Y, either end, or fit is impossible; so in fitting the irregular curves of the human figure we have to get rid of the "too muchness" by taking out wedges. How much and where, is the Cutter's problem. Diagram 5, is a representation of the current method; we take out at E, O and D—very rarely anything at A, unless for very marked abnormality. What, then, is the consequence?

Shaping by drawing in, pressing away of fullness, stretching, shrinking, and by some minor reductions, V's and slashes, we contrive to get a flexible material into something like respectable form. Happily, or unhappily, we have not to deal with inflexible goods—happily, because we now escape thereby downright failure which otherwise would be our lot; unhappily, because if we were forced to work out results with inflexible goods, we should have to put ourselves under practical scientific study, and, paradoxical as it may appear, principles would be sought and found, that may not yet for many a year dawn upon our contented and benighted understandings. We should then be driven to follow the curves and lines of the surface to be fitted, and though driven to our wit's end for some method of rectification, we have no doubt that a cleaner fit and a far higher artistic result would be achieved with the more difficult material. Diagram 4 shows what frequently occurs when a straight

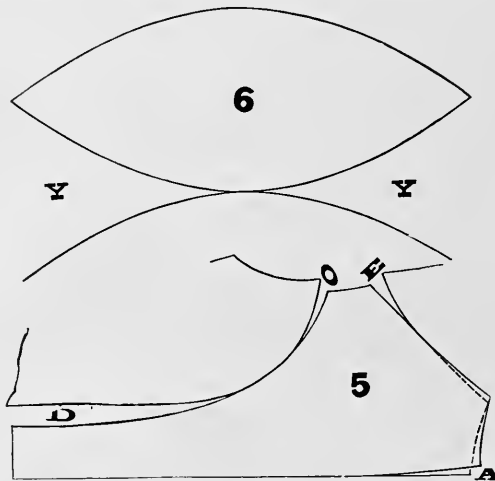

ILLUSTRATIVE DIAGRAMS 5 AND 6.

line in the back is made to cover a figure only slightly more bent forward than the normal one; there is a pucker or fullness at D, and no extra reduction as at E and O, Diagram 5, will remove it. Cut the back across as at O and O, Diagram 3, and the shoulder seam drops down, lapping over the superabundant goods, and the back seam if ripped open will fall forward at the top. Diagram 3 is purposely exaggerated to make the meaning clearer; an easy alteration can be made, provided an outlet has been left in the back seam.

Open the back seam from the socket bone to below the arm-seye level, and the gap will show at once what is wanted—the fault at D will have disappeared, showing plainly that a wedge ought to have been taken out at top of back, as well as at points of shoulder, top of side seam and bottom of same. No one would attempt to fit the curve of the blade without taking out wedges, and yet the same man will expect to get a clean surface on the curve of the back seam without it. A curved back seam with the right inclination, may actually have a shorter back and give a cleaner and more graceful style than the straight and longer one.

















LIBRARY OF CONGRESS



0 014 082 737 A

