

*GORDON'S WORK  
ON CUTTING  
MENS' GARMENTS*



Class TT590

Book G67

Copyright N<sup>o</sup> \_\_\_\_\_

COPYRIGHT DEPOSIT.







*GORDON'S WORK*  
ON  
*Cutting Mens' Garments*

---

---

**A COMPLETE TREATISE**  
ON THE  
**ART AND SCIENCE OF DELINEATING**  
**ALL GARMENTS FOR MEN**

*Especially Prepared for Self-Instruction*

BY S. S. GORDON

---

---

**Publishers :**  
**The S. S. GORDON COMPANY**  
**Huntington (L. I.) N. Y.**

COPYRIGHT, 1910,  
BY  
S. S. GORDON COMPANY

©Cl.A259993

# CONTENTS.

	PAGE
The Drafting-Square .....	8
The Measures for a Coat.....	10
Three-Button Cutaway Frock Coat, Body-Part.....	11
One and Three Button Frock Coat, Body-Part.....	16
Three Button Cutaway Frock Coat, Body-Part, Corpulent Form .....	18
The Arm-Scye .....	20
Frock Coat Backs.....	22
Whole Backs for Frock Coats.....	24
The Cutaway Skirt, Regular Form.....	26
The Cutaway Skirt, Corpulent Form.....	28
Double Breasted Frock Coat, Body-Part, Erect Form.....	30
Double Breasted Frock Coat, Body-Part, Corpulent Form..	34
High Padded Shoulders.....	36
Single Breasted Straight Front Frock Coat.....	36
Single Breasted Clerical Frock Coat.....	36
Frock Coat Skirt, Regular Form.....	38
Frock Coat Skirt, Corpulent Form.....	40
Frock Coat Skirt, Extra Drapery.....	42
Dress Coat, Regular Form, Body-Part.....	44
Dress Coat Skirt, Regular Form.....	46
Dress Coat, Body-Part.....	48
Dress Coat Skirt.....	52
Single Breasted Sack Coat, Regular Form.....	54

	PAGE
Single Breasted Sack Coat, Style-Effects.....	57
Long Roll Sack Coat Without Under-arm-seam.....	60
Double Breasted Sack Coat.....	62
Single Breasted Uniform Jacket.....	64
Single Breasted Sack Coat, Corpulent Form.....	67
Whole Backs for Sack Coats.....	72
The Sleeve .....	74
Overcoats, Allowance for extra size.....	78
The "Chesterfield" or Fly Front Overcoat.....	78
Fly Front Overcoat, Flared Skirts.....	82
Fly Front, Full Box Overcoat, Corpulent Form.....	86
The Inverness, Without Sleeves.....	89
The Inverness, With Sleeves.....	92
Double Breasted Full Box Overcoat, Square and Raglan Shoulders .....	94
The Raglan Sleeve.....	98
Fly Front Paletot.....	102
Surtout or Newmarket Overcoat.....	104
Three-Quarter or Military Cape.....	108
Half-Circle Cape .....	110
Close Cape .....	112
Hood .....	114
The Table of Proportionate Measures.....	117
How to use the Table for Proportionate Forms.....	116
How to use the Table for Disproportionate Forms.....	118
The Measuring Device.....	121
How to Measure,                               Coats .....	122
How to Measure,                               Vests .....	126

	PAGE
How to Measure.    Trousers .....	126
Single Breasted Vest, No Collar and Notch Collar.....	127
Single Breasted Vest, Coat collar effect.....	130
Double Breasted Vest.....	132
Clerical Vests .....	134
Single Breasted Vest, Corpulent Form.....	136
Cassock Vest .....	138
Dress Vest .....	140
Trousers, Regular Form.....	142
Peg Top Trousers.....	144
Trousers with Close-Fitting Legs and Spring Bottoms....	147
Some Variations in Trousers Cutting.....	150
Trousers with Broadfalls.....	154
Knee Breeches .....	156
Cycling Breeches .....	158
Riding Breeches .....	160
General Notes .....	33 and 107
S. B. Sackcoat .....	168
Fancy Cutaway .....	170
Opera Coat .....	172
The Importance of Right Measures.....	174



## INTRODUCTION.

**I**T is not necessary, upon your undertaking this course of instruction, that I should indulge in any remarks upon the high and honorable character of the vocation of a good cutter, or the liberal and substantial reward that is sure to attend those who are skillful and proficient as such. Your decision to prepare for that occupation is evidence that you appreciate the advantages which will be yours when you are fully equipped with the technical knowledge, which, (fortified by practical experience), is essential to one engaged in, or has a desire to excel in this, or in any profession. My earnest wish is that you have chosen an occupation for which you have good aptitude and natural ability. Then the way to success will be easy and you will derive pleasure and great satisfaction in your work. It will be very gratifying to know that, before a great while, you shall have attained distinction in the field of effort which you have chosen, and I stand pledged to do all I can to aid you in that direction. I only ask your earnest and steady co-operation.

Faithfully yours,  
S. S. GORDON.

## THE DRAFTING-SQUARE.

**Y**OUR attention is first directed to a clear understanding of the terms used in the explanations of the diagrams which are to follow, and relating to the Drafting-Square, a cut of which is herein shown.

In all these explanations, whenever the fractions  $1/6$ ,  $1/8$ ,  $1/4$ ,  $1/3$ ,  $1/2$ , etc., are used, unless expressly stated otherwise, they are according to the several divisions of "**one-half**" of the full size of the breast, waist or seat, as are to be found on the face side of the square shown on the illustration.

For example: The distance from any one point to another is given as  $1/4$  waist, the full waist being, say 32 inches. To determine the distance **find half** of 32, which is 16, on the divisions of **fourths**, which you will find is at "B" on the illustration. From there to the angle of the square at "A" is  $1/4$  waist, or 4 inches.

For a 36 waist,  $1/4$  waist is from the angle "A" to **half** of 36, (18), on the divisions of **fourths**, just beyond "B.". When it is said that from one point to another is **one full fourth**, (breast, waist or seat), then is meant a **full fourth**, which for a 32 waist is 8 inches. Note the difference then clearly between what is meant by  $1/4$  and a **full fourth**.

A **full half** of a 36 breast is 18 inches. But  $1/2$  of a 36 breast is from "A" to 18 on the divisions of **halves**, as at "C."

A **full sixth** of a 40 breast is 6  $2/3$  inches. But  $1/6$  is 20, (**one-half** of 40) on the divisions of **sixths**. One-third of a 40 breast is from A to G. To find  $2/3$  of a 44 seat, find half of 44, (22) on the division of "**two-thirds**," as at "H." From A to H is then  $2/3$  of a 44 seat.

Fix this clearly in your mind. When the words "half of the **full breast**, waist or seat" are used, it means a **full half**. But when **fractions** are used, as  $1/2$ , then is meant  $1/2$  of the breast, waist or seat as found on the drafting-square on the divisions of **halves**. And so all the way through, be it  $1/3$ rd,  $1/4$ th,  $1/6$ th,  $1/8$ th, or any other fraction, then is meant one-half of the full size **on the division of the drafting-square named**.

The divisions of 32nds, 16ths, 8ths, 4th and halves are on the short arm of the square. Those of 24ths, 12ths, 6ths, 3rds and  $2/3$ rds are on the long arm.

For **full sizes** use the reverse side of the square.



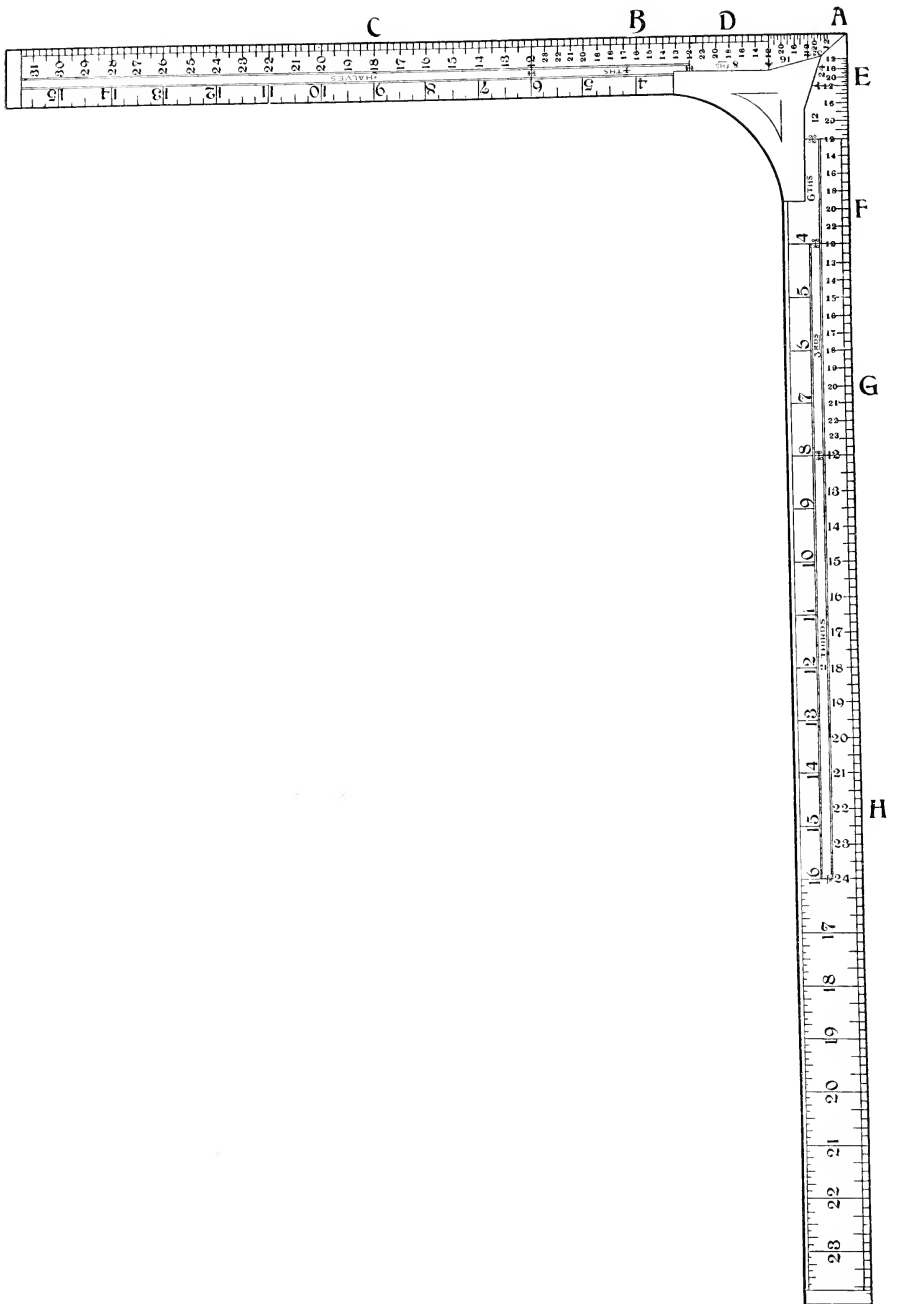

## THE MEASURES FOR A COAT.

THE measures used when drafting a coat pattern (in custom cutting), are as follows:

- |                            |                      |
|----------------------------|----------------------|
| 1—Breast.                  | 8—Full length.       |
| 2—Waist.                   | 9—Blade.             |
| 3—Seat.                    | 10—Front-scye depth. |
| 4—Half-back width.         | 11—Over-shoulder.    |
| 5—Back-scye depth.         | 12—Sleeve length.    |
| 6—Length to natural waist. | 13—Back waist.       |
| 7—Length to seat-line.     | 14—Arm-scye.         |

The seventh measure is omitted when measuring for frock-coats, and the length from the collar-seam to the fashionable waist is substituted.

Further on the manner in which the measures are taken is fully illustrated and explained. For the present the student must become familiar with the order in which they are taken, and should always adhere to the established order.

In the explanation of Diagram 1, I have taken pains to make everything so plain that it may be as clear to you as if I was talking to you at your side. When you have mastered that lesson it will not be necessary that I should repeat in the explanations of the diagrams which follow in the same extended manner, and the greater part that is contained in the explanation for Diagram 1, will not be repeated.

You should now provide yourself with a suitable table, some paper, either in sheets about 36 inches wide, or in rolls, some tailor's chalk, a couple of paper weights, a drafting-square, a tape-measure and paper shears. You should have some suitable piece of cloth for the top of your table, as you cannot draft as well when the paper is laid directly on the hard surface of the table. Use white chalk with colored paper and black chalk with white paper. Your tape-measure should be tested frequently, by your square or yard-stick. Some shrink and some stretch, and you must look out for that.

Remember the maxim "**Make Haste Slowly.**" Do not leave a lesson until you have fully mastered it, and each succeeding one will be the more readily acquired.

## THREE-BUTTON CUTAWAY FROCK-COAT.

### Plain or Natural Shoulder.

#### Diagram 1.

**T**HE measures used for the accompanying diagram are as follows, viz.: 36 breast,, 32 waist, 7 half-back width, 9 back-scye depth,  $16\frac{1}{2}$  natural-waist, 18 fashionable waist, 11 blade,  $12\frac{3}{8}$  front-scye depth 17  $\frac{3}{8}$  over-shoulder, 7  $\frac{3}{4}$  back-waist and 16  $\frac{1}{2}$  arm-scye.

Square the lines AE and A 19.

(To do this, place the drafting-square near the edge of the paper next to you, the long arm of the square lying as on the line from A to E, and the short arm extended across the paper at your right hand. The angle of the square will then be as at "A." Leave about 10 inches of paper at the right of the short arm, and when the square is in this position, mark with pencil or chalk close against the outer edges of both arms of the square. This gives the lines AE and A 19. By the way, your chalk needs to be sharpened to a thin, flat edge, so that you can mark close against the square. Hold the square in position firmly by the left hand so that it will not slip or turn.)

Place the angle of the square  $\frac{1}{4}$  inch below A and mark the back-scye depth, 9. This gives B. Then mark the length to natural-waist,  $16\frac{1}{2}$ . This gives D. Then mark the fashionable waist length, 18. This gives E. Remove the square. (The angle of the square is lettered "A." See illustration on page 9.)

From B to C is one-half of the back-scye depth. (The back-scye depth in this case is 9 inches and B and C is therefore  $4\frac{1}{2}$  inches.)

Square forward from C, B, D and E. (Lay the short arm of the square to touch all along on the line AE, with the long arm extended on your right hand side across the paper and the angle of the square at C. Then mark along the edge of the long arm towards 14. This is what is meant by "squaring forward." The line from C toward 14 is at a right angle, or square with the line AE.)

Now square forward in the same manner from B, D and E, only when squaring from D and E, let the long arm and the angle of the square be at your left hand and the short arm be extended upwards towards A. Be sure that the short arm touches the line AE its entire length, because if it does not, your lines will not be square with each other. To be a good cutter you must be square yourself and be able to draw lines square with each other.

D to F is  $\frac{1}{2}$  inch. Draw a light line straight from A to F.

(This is called a guide line), and shape the center-of-back seam as represented by the solid line. (This is rounded outward slightly from A to B, and slightly hollowed just above D.)

F to T is  $\frac{1}{8}$  breast,  $2\frac{1}{4}$  inches in this case. It may be made more according to style. (One-eighth of 36 breast is found by taking half of 36, which is 18, and finding 18 on the divisions of **eighths** on the square. See A to D on the illustration on page 9.)

Square downward from F and T by the waist-line D<sub>3</sub>.

Place the angle of the square at B and mark the blade, 11 inches. This gives K. Also mark a full half of the breast, 18 inches. This gives Q.

From K to L is  $\frac{3}{4}$  inch and K to M is  $1\frac{1}{2}$  inch.

From K to P is  $1\frac{1}{4}$  inch more than  $\frac{1}{6}$  breast. (Find half of the breast 18 on the divisions of **sixths** on the square. This is opposite 3 inches. So then,  $\frac{1}{6}$  of 36 breast is 3 inches, and  $1\frac{1}{4}$  inch more is  $4\frac{1}{4}$  inches.)

Q to R is  $2\frac{1}{2}$  inches. R to 2 is  $1\frac{1}{4}$  inch when the edges of the coat are to be stitched, and 1 inch when they are to be bound.

Square downward from K by the breast-line **B<sub>2</sub>** to establish S.

Square downward by the breast-line from M and R, and upward from M and P.

I is half-way B to M. From I to J is  $1\frac{1}{4}$  inch. Square upward from J to obtain the **natural** half-back width.

From C to Z is  $\frac{1}{2}$  inch more than the measured half-back width,  $7\frac{1}{2}$  inches in all. Square upward and downward through Z. This establishes 19. In this case the natural and the measured half-back width are alike.

A to G is  $\frac{1}{6}$  breast. (Half of the breast, 18 on the divisions of **sixths** which is 3 inches.)

Square upward from G. G to H is  $\frac{1}{24}$  breast,  $\frac{3}{4}$  inch. (Find half of the breast, 18 on the divisions of 24ths.)

Connect H and P by a straight line. From Z to 5 is 1 inch, or to style. Shape the back-scye from 4, which is  $\frac{1}{4}$ ,  $\frac{1}{2}$  or  $\frac{3}{4}$  inch, or more forward of the line above Z, according to style, to 5 and to K. (This is represented by a broken line from 5 to K.) The bottom of the scye is  $\frac{1}{4}$  inch below the breast-line.

Mark for the sleeve-notch at front of scye as at the unlettered point  $1\frac{1}{2}$  inch above M, and draw a light line from the notch to 5. Reshape the top of the sidebody from  $\frac{3}{8}$  inch forward of 5 to K, as represented by the heavy line.

Draw a light straight line from 19 to the center-of-back opposite E. This establishes 20 on the breast-line. Shape the back-part free handed from 5 through 20 to T, and the top of the back,

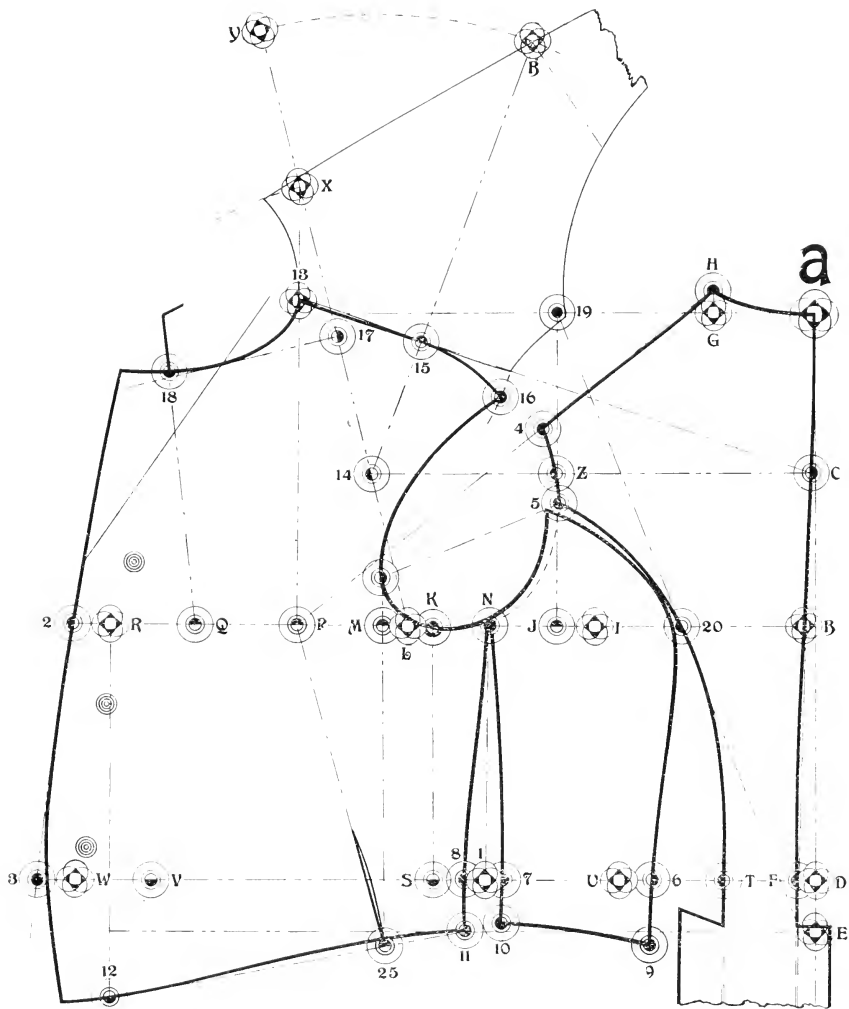

Diagram 1.

A to H, as represented. (The shoulder-seam edge of the back is hollowed slightly from a straight line from H to half-way from H to 4.)

From L to X is  $\frac{3}{4}$  inch more than the front-scye depth,  $13\frac{1}{8}$  inches in all. (This  $\frac{3}{4}$  inch is for the three seams between the front-of-scye and the center-of-back at the collar-seam, viz., one at the center-of-back at A, one at the back-shoulder and one at the front-shoulder. From L to Y is  $\frac{3}{4}$  inch more than the over-shoulder,  $18\frac{1}{8}$  inches in all. (This  $\frac{3}{4}$  inch is also for the same three seams as just explained.)

Connect L and X to establish 14.

Sweep forward from X, pivoting at L. (Take chalk in the right hand, place it on one end of the tape-measure with the other end extended towards the left hand. Place the chalk at X and extend the tape to L. Hold the tape by the left thumb at L and swing the right hand and chalk forward from X. The broken line represents the sweep-mark.)

Sweep backwards also in the same manner from Y, pivoting at 14.

From X to 17 is  $\frac{1}{4}$  breast,  $4\frac{1}{2}$  inches. (Half of the breast, 18 on the divisions of **fourths**.) Square forward from 17 by the line from X to L.

From F to T and S to U is the back-waist,  $7\frac{3}{4}$  inches. (Take the width from F to T, and whatever that is place it at S and mark backward  $7\frac{3}{4}$  inches. This gives U.)

N is half-way from I to M. Square downward from N to establish 1.

From T to 6 is 2 inches. Take the quantity between U and 6 and divide it equally on each side of 1 as represented. This gives 7 and 8.

(You will now observe that by measuring the draft from S to 8, 7 to 6 and T to F, that it is the same as the back-waist measure,  $7\frac{3}{4}$  inches, and that all the surplus through that part, which is represented by the quantity between U and T, has been eliminated, a part between T and 6, and the remainder between 7 and 8. This feature is not found in any other published system and is of the greatest value. Forms vary greatly in attitude, hollowness and fullness through the back-waist, and any system that distributes the material through that part by proportions, (in custom cutting), is very unreliable and is responsible for much very serious trouble. It is a misnomer to call any system of cutting a "**short-measure**" system which lacks this feature.)

Sharpen your chalk and proceed to shape the sidebody from  $\frac{3}{8}$  inch forward of 5, passing not more than  $\frac{1}{4}$  inch forward of 20 and through 6, also from N through 7 as represented.

(These lines are shaped free-handed. You will be assisted by first drawing light straight lines from N to 7 and N to 8. The front edge of the sidebody is slightly hollowed on the waist-line and has a slight spring forward from 7 to 10. The forepart is shaped a trifle backward of a straight line, just below N, crossing the straight line about halfway from N to 8, going a shade forward of it just above 8 and passing through 8 with a very slight backward spring towards 11.)

With the tape-measure take the distance from 20 on the side-seam of the backpart to the fashionable-waist line at E, and make from opposite 20 on the sidebody to 9 at the bottom  $\frac{1}{4}$  inch more.

Point 10 is  $\frac{1}{4}$  inch above the fashionable-waist line. Shape from 9 to 10 by a slightly downward curved line as represented.

From F to T and U to V is a full half of the waist, 16 inches.

From V to W is  $2\frac{1}{4}$  inches. From W to 3 is the same as R to 2.

Point 12 is 2 inches below the fashionable-waist line, or to **style**. Draw a light straight line from 11 to 12 and shape by a slightly reverse curved line from 11 to 12 as represented by the heavy line. (Do not raise more than  $\frac{1}{8}$  inch above the straight line at 25.)

Shape the fish from 25 toward P, hollowing  $\frac{1}{8}$  inch.

Cut out the backpart, leaving a small portion of paper from A to H and lay it in the position shown on the upper part of the diagram. H is on the line which is squared upward from P; A is on the sweep-line forward of X and B touches the sweep-line backward of Y. When in this position place a weight on the backpart, mark point B and draw a straight line from B to 14. Mark lightly along the edge of the backpart from H to 4.

This establishes 15. Shape the front-shoulder from 13 through 15, hollowing slightly just backward of 13 and rounding off about  $\frac{3}{4}$  inch below the outer back-shoulder point towards 16.

From 13 to 16 is the same as from H to 4 on the backpart. Finish the scye from 16 to the front-scye notch as represented.

Shape the gorge by a graceful curve from the center of the top of the backpart at A through 13 and on towards 18 as represented, or higher or lower than 18, according to **style**.

Shape the front above and below the end of the roll, according to **style**, and draw the reverse crease-line from  $\frac{1}{2}$  inch forward of 13 to the end of the roll.

The buttons are placed  $1\frac{1}{2}$  inch from the front edge.

The skirts for this coat are explained further on.

Study this lesson very carefully and practice on full size drafts. Read the instructions over and over until you are familiar

with them. Fasten in your mind the several points and each succeeding lesson will be more easily mastered as all points are correspondingly lettered and numbered and the same principle underlies the construction of all body-coats. Work with well sharpened chalk and on each draft endeavor to improve in gracefulness and accuracy of all lines and curves.

Send us an uncut draft by mail for examination and correction, and proceed with the study of the next lesson.

## ONE AND THREE-BUTTON CUTAWAY FROCK-COAT.

(For a Stout, Stooping Shouldered Form.)

### DIAGRAM 2.

**T**HE measures used for the accompanying diagram are as follows, viz.: 42 breast, 40 waist,  $8\frac{1}{4}$  half-back width, 10 back-scye depth,  $17\frac{1}{2}$  natural waist, 19 fashionable waist,  $12\frac{1}{2}$  blade,  $13\frac{1}{2}$  front-scye depth,  $19\frac{1}{2}$  over-shoulder,  $9\frac{3}{4}$  back-waist,  $18\frac{1}{2}$  arm-scye.

#### To Draft.

All the points excepting 19 and Z are obtained in the same manner as explained for Diagram 1.

As the back-scye depth in this case is more, and the front depth less than for a regular form, point 13 falls below the line which is squared across from A.

The dotted line above J gives the natural half-back width applicable to a regular form as explained for Diagram 1. The measurement for the half-back width in this case is **more** than for a regular form and is applied as follows:

C to Z is  $\frac{1}{2}$  inch more than the half-back width,  $8\frac{3}{4}$  inches.

Square upward and downward from Z. This establishes 19.

In the absence of a measure for the half-back width the line above J gives the **natural** width of back. It is regulated by a fixed proportion of the width from B to M. It is always safe, however, to take the width in each case in custom cutting because all forms are not proportionate, some requiring a wider, and some a narrower back than a proportionate form. It is well to know what the proportionate width is, and your observation of the shape of the form you are required to dress will aid you to determine the accuracy or inaccuracy of your measure when it differs greatly from that for a proportionate form.

The front edge for the one-buttoner is represented by the broken line extending from the top of the rever through 2 and W.



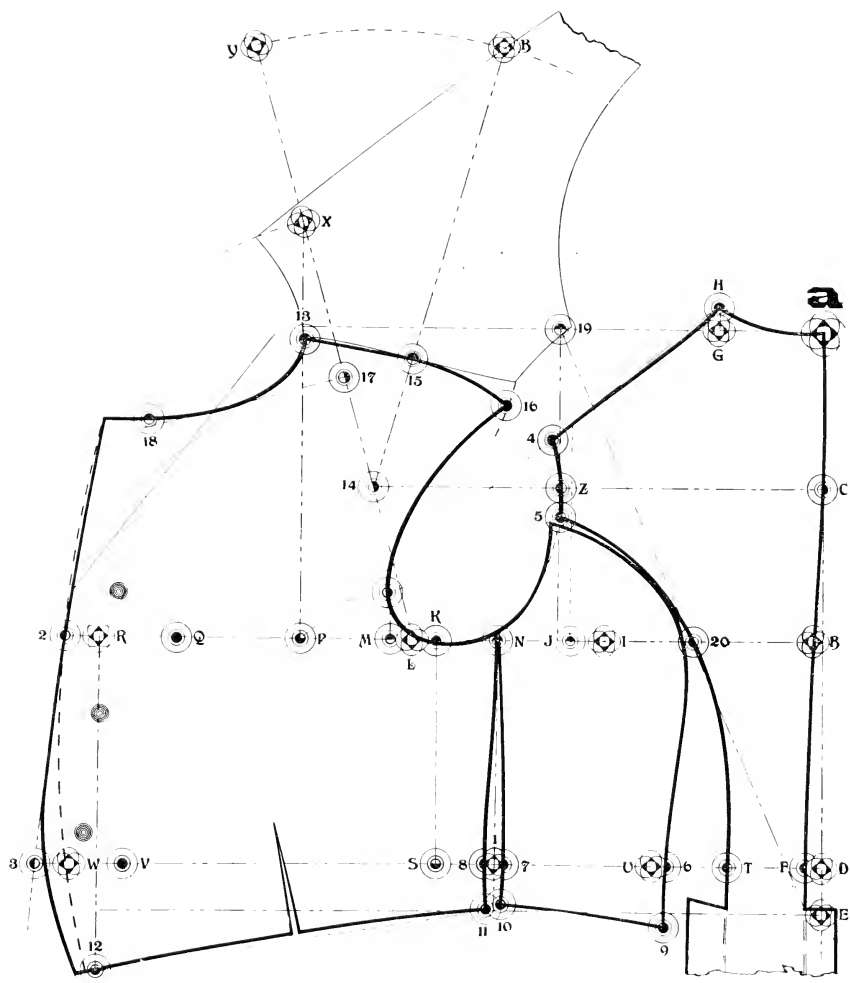

Diagram 2.

It should be  $\frac{1}{4}$  inch larger at the front edge opposite the top button than the three-buttoner.

Establish the end of the roll; shape the rever and fronts according to the prevailing **style**.

Shape the fish on the waist-line as represented. It is about half-way between 11 and 12. For more corpulent forms it is placed as shown on Diagram 3.

### THREE-BUTTON CUTAWAY FROCK-COAT.

(Good Form, Corpulent.)

#### Diagram 3.

**T**HE measures used for the accompanying diagram are as follows, viz.: 42 breast, 45 waist, 8 half-back width,  $9\frac{3}{4}$  back-scye depth,  $17\frac{1}{2}$  natural waist,  $19\frac{1}{2}$  fashionable waist,  $12\frac{1}{2}$  blade,  $14\frac{1}{8}$  front-scye depth,  $19\frac{1}{2}$  over-shoulder,  $10\frac{1}{4}$  back-waist,  $18\frac{1}{2}$  arm-scye.

#### To Draft.

Obtain all the points except 6, 7, 8, 19 and Z in the same manner as explained for Diagram 1.

The dotted line above J gives the natural half-back width applicable to a regular form. The measurement for the half-back width in this case is more than as required for a regular form and an observation of the form justifies the variation. The measured width is therefore applied as follows: C to Z is  $\frac{1}{2}$  inch more than the measured width,  $8\frac{1}{2}$  inches in all.

Square upward and downward from Z. This establishes 19.

F to T and S to U is the back-waist,  $10\frac{1}{4}$  inches.

F to T and U to V is one full half of the waist  $22\frac{1}{2}$  inches.

T to 6 is 2 inches, except when this amount would establish 6 forward of U. In that case the backseam of the sidebody is shaped through U instead of through 6. There will then be nothing remaining to be taken out at the underarm seam between 7 and 8. In this case U and 6 are in the same position and there is no surplus between U and 6, and there is nothing to be taken out as between 7 and 8 on the preceding diagrams.

Square upward by the line from 11 to 12 towards Q, and make the V  $\frac{1}{16}$ th inch wide for each inch that the waist is more than a waist 4 inches smaller than the breast. A waist 4 inches less than 42 breast is 38. So that in this example, the waist is 7 inches larger than that for what is usually called a regular form, and the V is  $\frac{7}{16}$ ths wide.

Shape from 11 to the V as heretofore explained. Forward

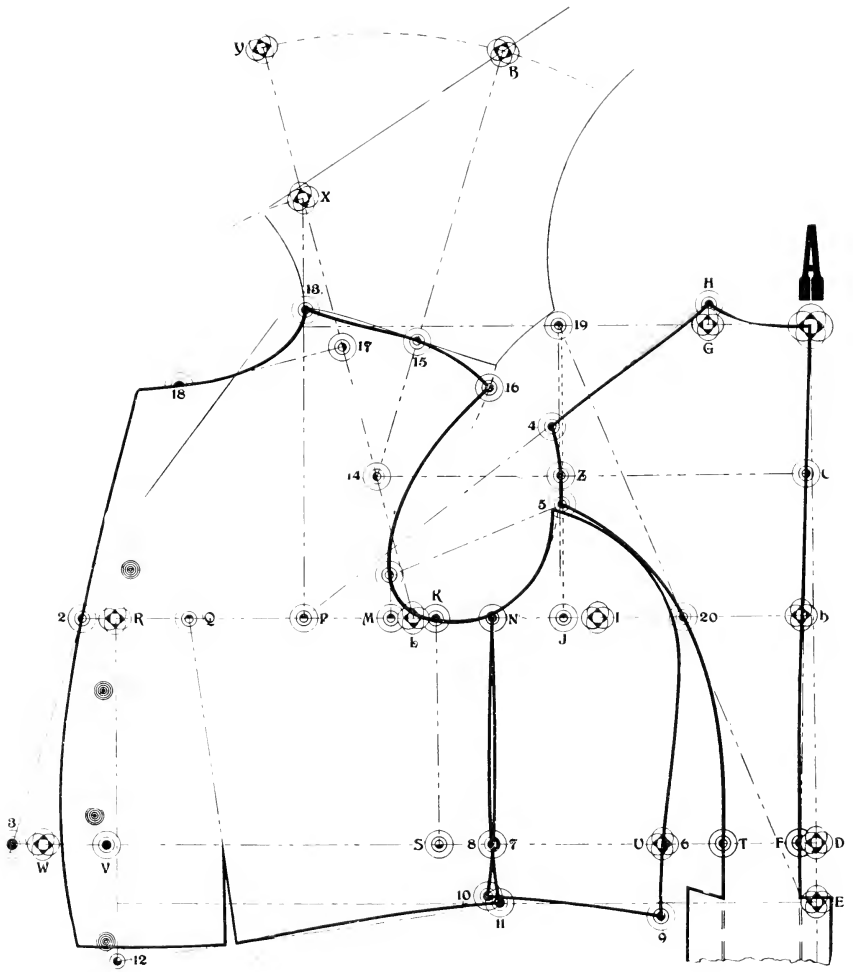

Diagram 3.

of the V the waist seam is shaped the same amount above 12 as the width of the V.

Draw a light straight line through 2 and 3. This would represent the front edge for a 3 or 4 button-up coat, which should be rounded off from near 3 as shown on Diagram 2, or to style.

This coat is intended to be buttoned at the top button only, below which it is gradually cut away, passing the waist-line as much backward of 3 as the **style must determine**, as represented by the heavy line.

The width and shape of the rever above the end of the roll; the length of the roll and run of the neck-gorge (13 through 18) may be as represented, but they are all matters which are governed by the **prevailing style**. The service button is placed  $1\frac{1}{2}$  inch backward of the front edge.

## THE ARMSCYE.

### Diagram 4.

**A**LL reference to the measure for the armscye has been purposely omitted in the explanations for the preceding diagrams. In most cases the front-shoulder seam will be right for a plain shoulder when drafted as has been previously explained. The application then of the scye measure will not necessarily change the run of the shoulder seam, but will enable you to determine in advance if the outer shoulder requires more than the usual amount of padding, etc. For a person who does not exercise the shoulder and arm muscles the scye will measure small, and in any case when the application of the measure would bring point 16 much lower than as represented, then the measure should be sacrificed to **good form** and the outer shoulder points should be built by padding, etc. To apply the scye measure proceed as follows:

Place the end of the tape-measure at the front-scye notch (point 2), and measure around to 4, following the broken line which is  $\frac{1}{4}$  inch from the edge of the scye.

We will suppose that this measures  $11\frac{1}{4}$  inches. Then place  $11\frac{1}{4}$  at 2 and following the broken line to 16 we find that the scye measure  $16\frac{1}{4}$  with  $1\frac{1}{2}$  inches added for six seams falls on the line of the shoulder seam as on the diagram from 15 to 16.

It will readily be seen that, had the measure taken on the form have been  $15\frac{1}{2}$ , and had the shoulder seam been shaped to the measure, then point 16 would have been  $\frac{3}{4}$  inch below

the position it now occupies on the diagram, and the seam if shaped backward of 15 according to the measure would **not be in good form**. In such case the seam must be given good form and any deficiency on the part of the wearer must be provided for by building up the outer shoulder points.

Point 15 may fall above or below the line from 13 to C as the application of the over-shoulder measure will establish it.

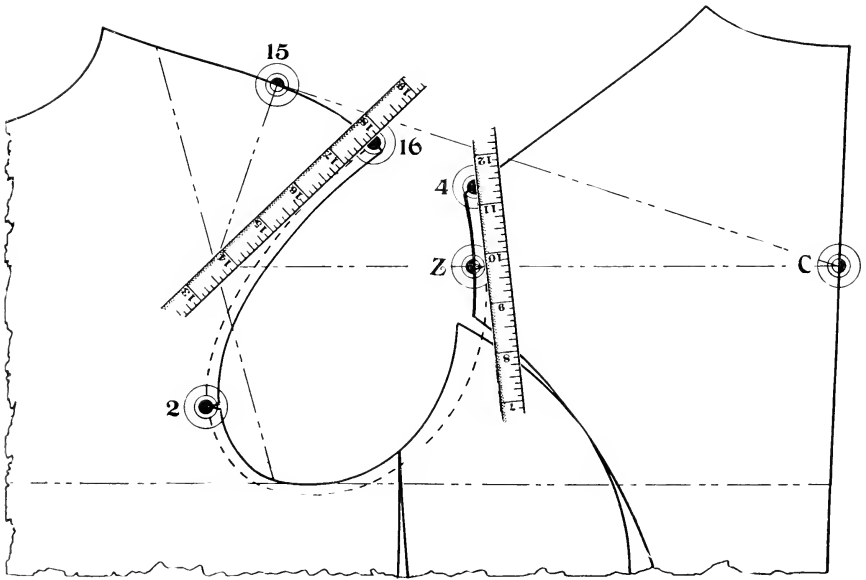

Diagram 4.

## FROCK-COAT BACKS.

### Diagram 5.

**T**HE regular back is drafted as represented except when the material is a decided stripe or plaid.

Points A and E are the same as on the preceding diagrams. To complete the back-skirt extend the line AE towards G and proceed as follows:

A to E is  $\frac{1}{4}$  inch more than the fashionable-waist length, and on to G is  $\frac{1}{2}$  inch more than the full length.

E to F is  $\frac{1}{2}$  inch. G to J is  $\frac{1}{2}$  inch.

F to H is  $\frac{1}{8}$  breast, or **to style**. J to K is  $\frac{1}{4}$  inch more than F to H.

Curve slightly from H to K and add 1 inch on each side of F and H, extending from  $\frac{1}{4}$  inch above F and H as represented.

### Diagram 6.

For stripes and plaids of prominent patterns, the back is first drafted in all respects the same as on Diagram 5 and as defined by points A, E, F, G, H, J and K.

Continue the line AF to establish L.

L to M is the same as J to K.

Reshape the back-skirt from F and H to L and M.

The top of the plait should be raised about  $\frac{1}{2}$  inch above H, and the bottom  $\frac{1}{4}$  inch above M.

When making, the center back must be well shrunk at the natural waist, and the sideseam stretched directly opposite, until the edge below F ranges with the line FJ.

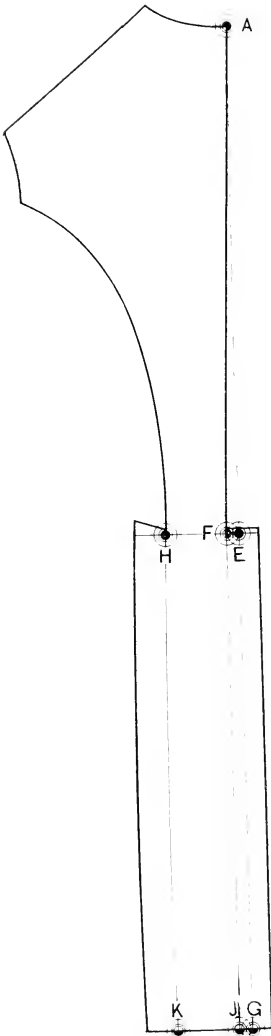

Diagram 5.

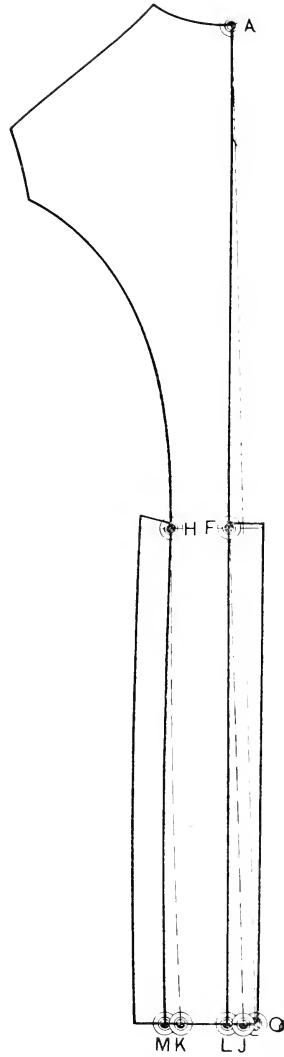

Diagram 6.

## WHOLE BACKS FOR FROCK-COATS.

**D**IAGRAMS 7, 8, 9 and 10 are for one style of whole back.

Diagram 7 represents the back as cut from the material. It is drafted in the same manner, and points A, F, H, L and M are the same, as on Diagram 6.

Diagram 8 represents the material opened out face upward and cut off on the right side from  $\frac{1}{4}$  inch below H to within 1 inch of the center and down to the bottom.

Diagram 9 represents (the shaded part) another piece which is cut by the pattern of the back-skirt, with 1 inch added for the back tack. The top is cut  $\frac{1}{4}$  inch above F and H.

Diagram 10 shows the piece (Diagram 9) attached to the back (Diagram 8). It is seamed to the back from the button to the tack, passing under the left back-skirt.

When the piece (Diagram 9) is to be stoated to the back instead of seamed, the top should be cut off on the line FH.

Diagram 11 represents another style of whole back without the crosscut on the fashionable-waist line. The extra piece, which is shaded, extends from the right side 1 inch or more beyond the center, and is fastened at the button and by a tack at the center of back. One side-edge is left free.

When marking on the material the center-of-back is laid to overlap the fold or crease-edge  $\frac{1}{4}$  inch from the top to the bottom, or the width may be reduced  $\frac{1}{4}$  inch from A to L and then the back-center laid even with the fold of the material.

The material must be well shrunken on the fold at the natural waist, and stretched on the side directly opposite.



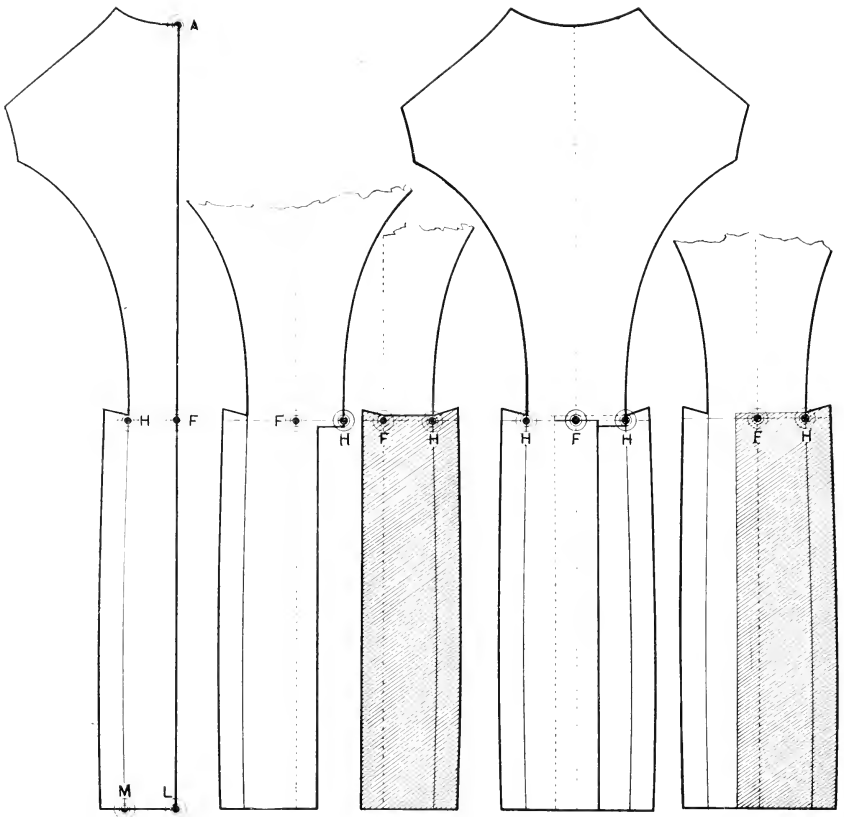

Diagram 7. Diagram 8. Diagram 9. Diagram 10. Diagram 11.

## THE CUTAWAY SKIRT.

(Regular Form.)

### Diagram 12.

**S**QUARE the lines AB and AC.

Lay the sidebody to touch the line AB as represented and mark along the edge of the pattern from A to D.

Lay the forepart with the lower point of the sideseam at D, and the fashionable-waist line directly over the line AB. Mark along the edge of the pattern from D to F.

F to G is  $\frac{1}{2}$  inch. E is half-way from A to E.

Shape the waist seam from E by a slightly curved line to G as represented.

A to C is 9 inches for a form of average height, or half the length from the collar-seam to the natural waist.

When the seat is 5 inches larger than the waist, C to J is  $2\frac{1}{2}$  inches (the seat taken close as for trousers). Take for example a 32 waist and 37 seat. The difference is 5 inches, and C to J is  $2\frac{1}{2}$  inches. When the difference is more than 5 inches, then from C to J is  $\frac{1}{4}$  inch more than  $2\frac{1}{2}$  inches for each inch that the difference is more than 5 inches. When the difference is less than 5 inches proceed as is explained for the next diagram.

The distance from C to J as above stated is for skirts that are to be **French pressed**. When they are to be plain pressed make C to J  $\frac{1}{4}$  inch less.

Draw a straight line from A through the unlettered point  $\frac{1}{2}$  inch forward of J.

A to R is 24 inches. R to T is 1 inch.

Shape the back crease-edge by a curved line from A through J towards T.

A to L is  $\frac{1}{4}$  inch more than the length of the back-skirt.

Lay the forepart in close position with the skirt, F touching G, and shape the front as represented, **or to style**.

Add 1 inch to the back crease-edge for the plait.

Two styles are represented on the diagram.

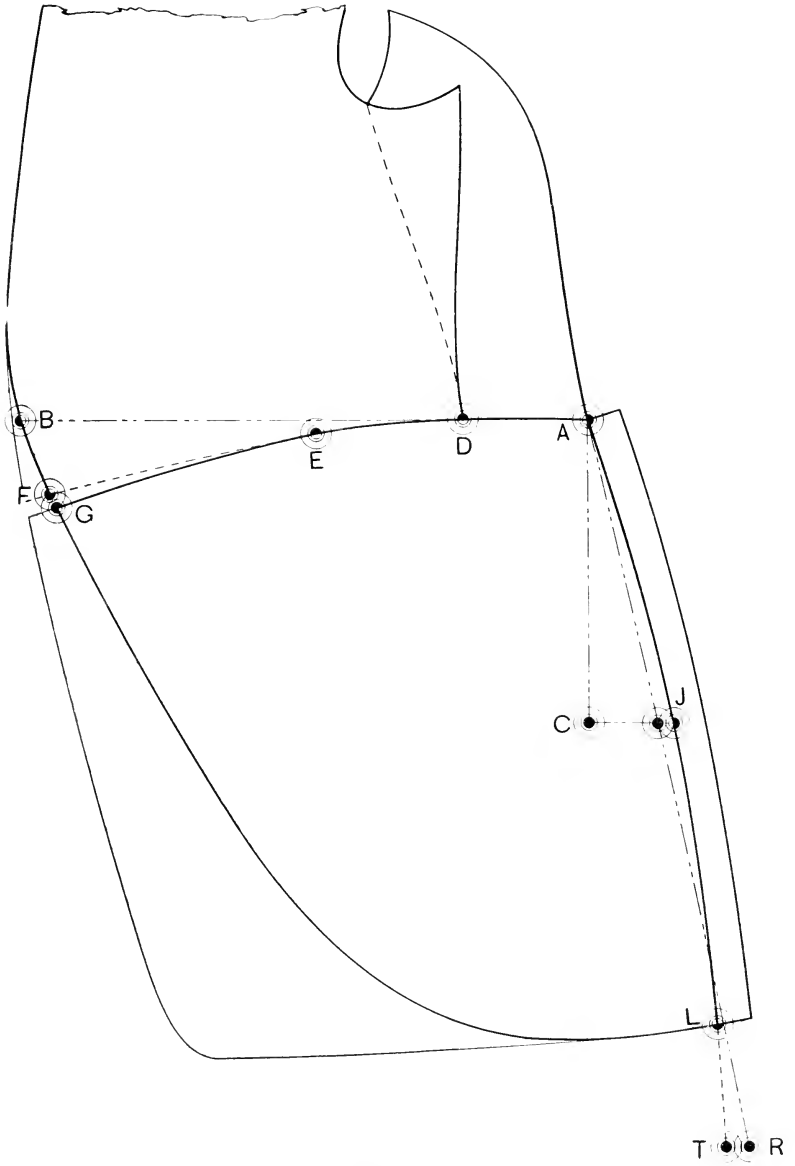

Diagram 12.

## THE CUTAWAY SKIRT.

(Corpulent Form.)

### Diagram 13.

**S**QUARE the lines AB and AC.

Lay the sidebody to touch the line AB as represented and mark along the edge of the pattern from A to D.

Lay the forepart with the lower point of the sideseam at D and the fashionable waist line directly over the line AB. Mark along the edge of the pattern from D to the dart at H, and continue the line as to the small disk.

From the small disk to G is  $\frac{1}{2}$  inch.

E is half-way from A to F.

Shape the waist-seam from E by a slightly curved line to G as represented.

A to C is 9 inches for a form of average height, or half the length from the collar-seam to the natural waist.

C to K is  $2\frac{1}{2}$  inches.

K to J is as many quarters of an inch as the difference between the waist and seat is less than 5 inches.

For example: Take a form of 40 waist and 42 seat (the seat taken close as for trousers). The difference (2 inches) is 3 inches less than 5 inches. Therefore from K to J is  $\frac{3}{4}$  inch.

Draw a straight line from A through the unlettered point  $\frac{1}{2}$  inch forward of J.

A to R is 24 inches. R to T is  $\frac{1}{2}$  inch.

Shape the back crease edge by a curved line from A through J towards T.

A to L is  $\frac{1}{4}$  inch more than the length of the back-skirt.

Lay the forepart in closed position with the skirt, F touching G, and shape the front as represented, **or to style.**

Add 1 inch to the back crease-edge for the plait.

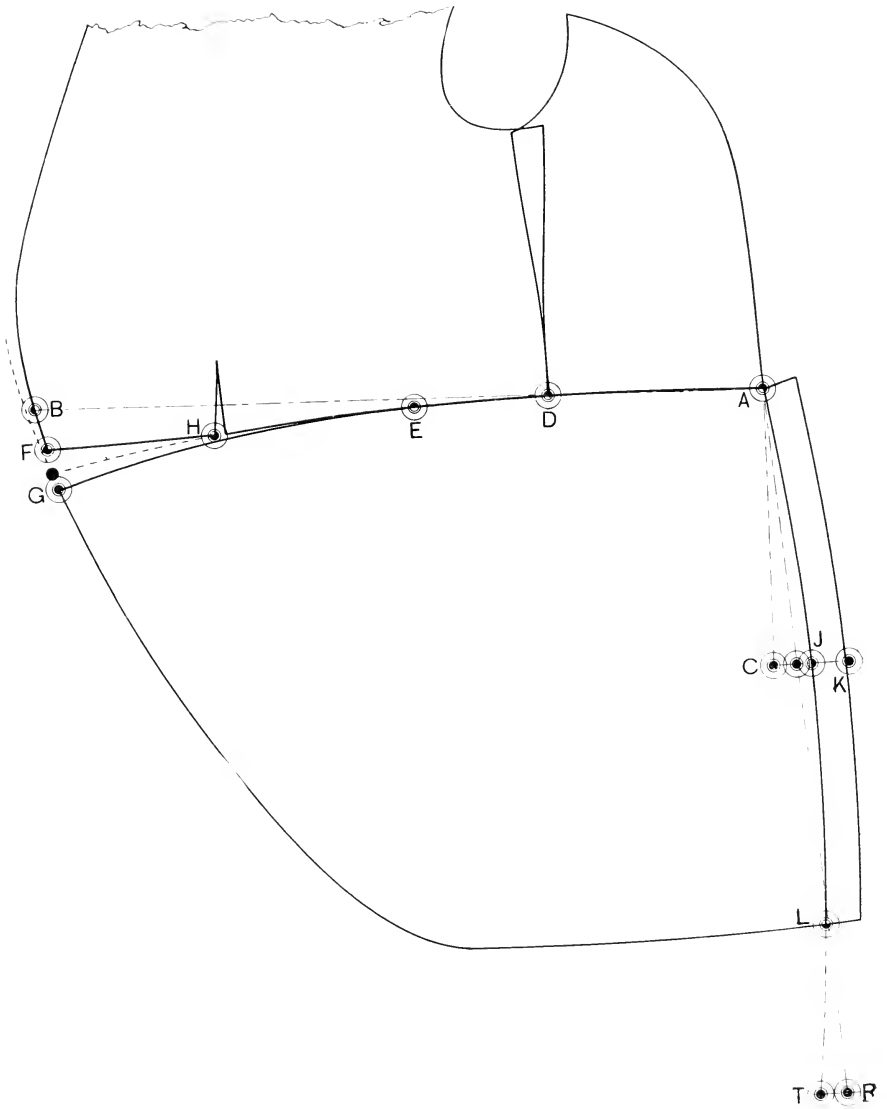

Diagram 13.

## DOUBLE-BREADED FROCK COAT.

(Erect Form.)

### Diagram 14.

**T**HE measures used are as follows: 38 breast, 34 waist,  $7\frac{3}{8}$  half-back width, 9 back-scye depth,  $17\frac{1}{2}$  natural waist,  $19\frac{1}{4}$  fashionable waist,  $11\frac{1}{4}$  blade, 13 front-scye depth,  $18\frac{1}{4}$  over-shoulder,  $8\frac{1}{4}$  back-waist, 17 arm-scye.

### To Draft.

Square the lines AE and A 19.

Place the end of the tape-measure  $\frac{1}{4}$  inch below A and mark the back-scye depth 9 at B, the natural waist  $17\frac{1}{2}$  at D, the fashionable waist  $19\frac{1}{4}$  at E and the full length as explained for Diagram 5.

B to C is one-half of the scye depth,  $4\frac{1}{2}$  inches. Square across from B, C, D and E and at the full length.

D to F is  $\frac{1}{2}$  inch. Connect A and F and shape the center-back from A to F as represented. Square downward from F.

B to K is the blade,  $11\frac{1}{4}$  inches.

K to M is  $1\frac{1}{2}$  inch. L is half way from K to M.

K to P is  $1\frac{1}{4}$  inch more than  $\frac{1}{6}$  breast,  $4\frac{3}{8}$  inches.

B to Q is one full half of the breast, 19 inches. Q to R is  $2\frac{3}{4}$  inches.

I is half way from B to M. I to J is  $1\frac{1}{4}$  inch. Square upward J, M and P, and downward from K and M. (The line above J gives the natural half-back width.)

C to Z is  $\frac{1}{2}$  inch more than the measured half-back width,  $7\frac{7}{8}$  inches in all. Square upward and downward from Z to establish 19.

A to G is  $\frac{1}{6}$  breast,  $3\frac{1}{8}$  inches. G to H is  $\frac{1}{24}$  breast, full  $\frac{3}{4}$  inch. Connect H and P. Connect A and M to establish 5.

Shape the back-scye from 4 to 5 and as represented by the broken line from 5 to K.

Establish the front-scye notch  $1\frac{1}{2}$  inch above M and reshape the scye from  $\frac{3}{8}$  inch forward of 5 as shown by the solid line. The bottom of the scye is  $\frac{1}{4}$  inch below the breast-line.

F to T is  $\frac{1}{8}$  breast,  $2\frac{3}{8}$  inches, or **to style**.

Connect 19 and the center-back at the fashionable waist line to establish 20 and shape the side-back as represented.

N is half-way from I to M. Square downward from N to establish 1.

F to T and S to U is the back-waist  $8\frac{1}{4}$  inches (or, S to U is the back-waist, **less the width of the back from F to T**).

F to T and U to V is one full half of the waist, 17 inches.  
 V to W is  $2\frac{1}{2}$  inches.

Shape the center-of-front through R and W as represented.

T to 6 is 2 inches. From 7 to 8 (distributed equally on each side of 1) is the same as U to 6,  $\frac{3}{4}$  inch for this draft.

Shape the sidebody from  $\frac{3}{8}$  inch forward of 5, passing  $\frac{1}{4}$  inch forward of 20 and through 6 and make the length to 9  $\frac{1}{4}$  inch more than from 20 to the fashionable-waist line on the backpart.

Shape the underarm seam from N through 7 and 8 as represented.

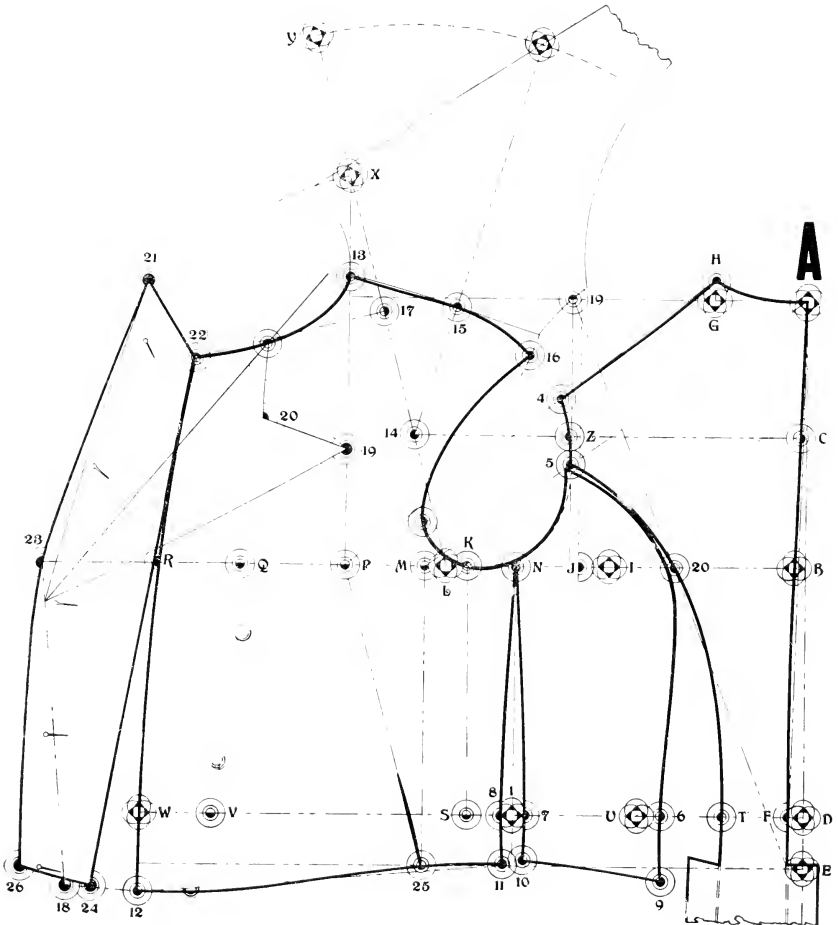

Diagram 14.

Point 10 is  $\frac{1}{4}$  inch above the fashionable-waist line, and from the same line to 12 is 1 inch. Connect 11 and 12 by a light straight line.

The fish is shaped from 25 towards P. It is  $\frac{1}{8}$  inch wide at the natural waist.

L to X is  $3\frac{1}{4}$  inch more than the front-scye depth,  $13\frac{3}{4}$  inches.

L to Y is  $3\frac{1}{4}$  inch more than the over-shoulder, 19 inches. Connect L and X to establish 14.

Pivot at L and sweep forward from X. Pivot at 14 and sweep backward from Y.

X to 17 is  $\frac{1}{4}$  breast,  $4\frac{1}{2}$  inches. Square forward from 17.

Cut out the backpart and lay it in the position shown on the upper part of the diagram. Point H is on the line which is squared upward from P, A is on the sweep-line from X, and B on the sweep-line from Y.

Place a weight on the backpart; mark along the back-shoulder seam and shape the gorge as represented, **or to style**. This establishes 13.

Connect 14 and B to establish 15. Remove the pattern and shape the shoulder from 13 through 15, rounding off about  $3\frac{1}{4}$  inch to 16 and finish the scye from 16 to the scye notch.

Pivot at the neck and center-of-front, which in this case is at 22, and sweep forward and backward from 12. Shape the waist seam by a graceful reverse curve from 11 to 12 as represented.

From 12 to 24 is  $1\frac{1}{2}$  inch. From 12 to 18 is  $2\frac{1}{2}$  inches. R to 23 is 4 inches, **or to style**. Shape the lapel seam above 24 as represented.

Connect 23 and 18, establish the end of the roll and draw the crease line towards a point  $3\frac{1}{4}$  inch forward of 13.

Establish 19 and 20 **according to style** and square forward by the crease-line from both points. From the crease-line to 21 is the same as to 19 and from the same line to 22 is the same as to 20.

The light line from 21 to the end of the roll and on to 18 shows the approximate run of the front of the lapel when it is closed to the forepart.

From 24 to 26 is the same as 12 to 18. Shape from 21 to 26 passing the same amount forward of the end of the roll as drawn, as is taken out between the lapel and forepart below R and opposite the end of the roll.

Pivot at 22 and sweep backward from the eye of each button-hole and establish the buttons  $3\frac{1}{4}$  inches less from the line R to 12 than the width of the lapel. (See diagram 47.)



## NOTES.

**T**HE width of the top of the backpart may be made more or less than as herein explained for any coat or vest. This width is entirely a matter of **taste or style**.

The back shoulder-seam may be drawn from H to P, Q or R, **according to style**.

Sidebodies are cut  $\frac{1}{4}$  inch shorter, from N to 10 than the forepart from N to 11. The sidebody should be stretched this  $\frac{1}{4}$  inch opposite 7.

Collars should go on full at the side of the neck opposite the shoulder seam and short from the crease-line to the front. The gorge should be stretched at the side of the neck from the crease-line to the front-shoulder seam, except for those who carry the head well forward.

Study repeatedly the article "How to Measure."

The back-scye should be drawn in  $\frac{1}{2}$  inch below Z and the under-sleeve full on the same amount.

The front-scye should be stretched just below 16.

For round-shouldered forms the back-shoulder may be cut a trifle longer from H to 4 than the front shoulder from 13 to 16 and the extra length full on to the front shoulder.

The backpart should be full on to the sidebody a very little over the blades between 5 and 20.

The width of the backpart from F to T may be made **any style width**, and the side-back seam may be shaped with more or less curve than as shown on any of the diagrams for coats.

For a form with full round breast, the front-scye should be drawn in a trifle at the front-scye notch.

For a form having a very long neck make the width of the stand of the collar  $1\frac{1}{2}$  inch, and for one with very short neck 1 inch wide.

(See page 107.)

## DOUBLE-BREADED FROCK-COAT.

(Corpulent Form.)

### Diagram 15.

**T**HE measures used are: 46 breast, 45 waist,  $8\frac{5}{8}$  half-back width,  $10\frac{1}{4}$  back-scye depth,  $17\frac{3}{4}$  natural waist,  $19\frac{3}{4}$  fashionable waist,  $13\frac{1}{2}$  blade,  $15\frac{3}{8}$  front-scye depth,  $20\frac{3}{4}$  over-shoulder,  $11\frac{1}{4}$  back-waist,  $19\frac{1}{2}$  arm-scye.

### To Draft.

Obtain all the points excepting 1, 2, 12, 21, 22, 24 and O in the same manner as explained for Diagram 14.

F to T and S to U is the back-waist as before.

T to 6 is 2 inches, except when this amount would establish 6 forward of U. Then the backseam of the sidebody is shaped through U instead of through 6, and nothing is taken out on the waist-line below N.

In this case, as point 6 is backward of U, viz.,  $\frac{1}{4}$  inch, from 7 to 8, is therefore the same as U to 6, viz.,  $\frac{1}{4}$  inch.

Square downward from R.

Point 12 is 2 inches below the fashionable waist line. Connect 11 and 12 and square upward by this line to Q.

Make the dart  $\frac{1}{16}$  inch wide for each inch that the waist is more than a waist 4 inches smaller than the breast. In this case the waist is 3 inches more than 4 inches smaller than the breast, and the dart is  $\frac{3}{16}$  inch wide.

Pivot at R and sweep downward from B.

Take the length from R to B, and, pivoting at X make a cross-sweep to establish O.

Pivot at O and sweep from R to X to establish 2.

Shape the center-of-front through 2 and W as represented. For forms of excessive corpulency, this line will be a reverse curve passing a trifle forward of R. For forms less corpulent it should pass by a uniform curve from 2 through R to W.

Pivot at 2; sweep forward from 1 and shape from 1 to 11 as represented.

Pivot at W and sweep forward from 18. From 18 to 24 is  $13\frac{3}{4}$  inch.

Connect 21 and 24 and shape the lapel-seam edge by a slightly reversed curved line as represented.

Pivot at 24 and sweep forward from 21.

The width and shape of the lapel above 24 is governed by

**style.** On the diagram it is  $2\frac{3}{4}$  inches wide at the top,  $3\frac{1}{2}$  inches opposite R and  $2\frac{1}{2}$  inches at the bottom.

Lay the lapel in closed position at the top with the forepart as represented in broken lines and draw the lapel crease-line from  $\frac{1}{2}$  inch forward of 13 to the end of the roll. This establishes 22.

The shape of the lapel may also be made to conform with the current style by obtaining all the style points as explained for the preceding diagram.

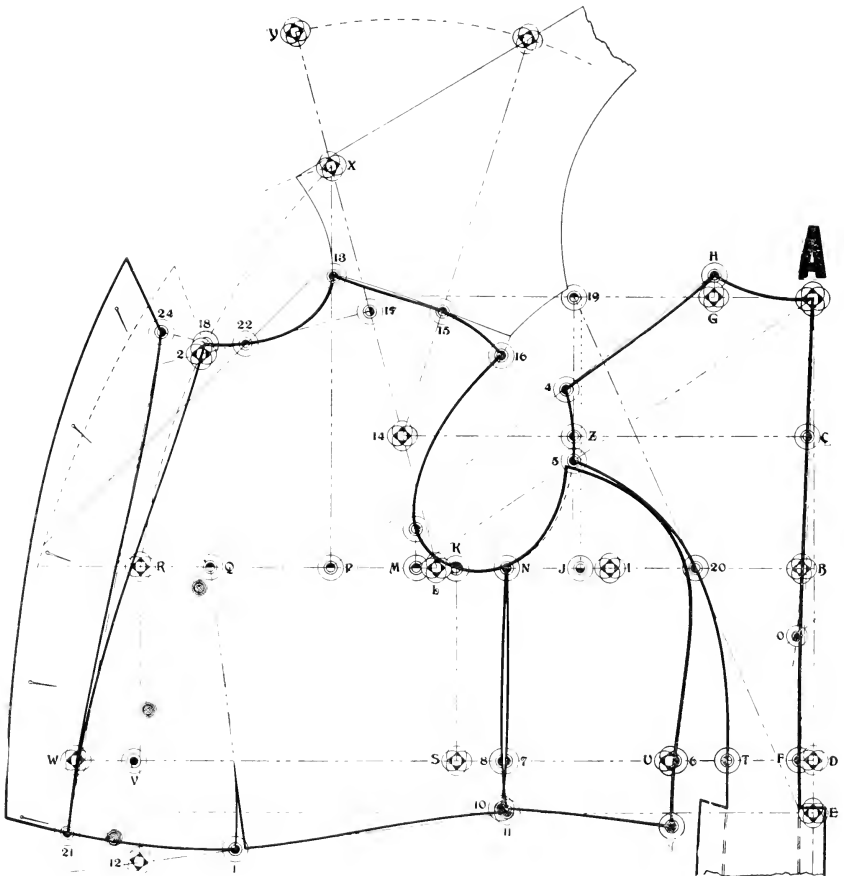

Diagram 15.

## HIGH PADDED SHOULDERS.

**O**N ALL the diagrams contained in this work, unless expressly stated otherwise, the shoulders are drafted to the measures as taken over the vest. This gives a **plain shoulder** which requires but little padding, only sufficient to give good form. When for any reason a high padded shoulder is required proceed as follows:

Refer to Diagram 16 and observe that this shoulder is first drafted plain, as represented by the heavy lines. A line is then drawn across as from 18 to 19, and a tracing is made of the part above the line, is cut out and laid on the draft. Pivot this at 18 and swing the scye end upward as much as required as represented by the part which is shaded. Then mark around it. The top of the back-shoulder may be made wider (H to 4. Diagram 15) if **style demands**, and the width of the front-shoulder is increased to the same width.

## SINGLE-BREASTED STRAIGHT FRONT FROCK-COAT.

### Diagram 16.

**A**LL the points are obtained in the same manner as explained for Diagram 1.

The forepart only is shown, the front of which is continued straight below 3 to the waist-seam.

## SINGLE-BREASTED CLERICAL FROCK-COAT.

### Diagram 17.

**A**LL the points on the body of the forepart excepting 2, 3, 4, 5 and 6 are obtained in the same manner as explained for Diagram 1.

Points 17 and 2 are obtained in the same manner as explained for Diagram 15.

The line 2, R, W is the center-of-front and the button-line.

The end of the gorge at 3 is obtained by the application of the measures for half-size of neck and depth-of-gorge. The manner in which these two measures are taken are explained further on. (See "How to Measure, Clerical Coats, etc.") These two measures are applied to the draft in the following manner:

Place the width of the top of the backpart at 13 and extend the tape-measure to W. Hold it at W; release it from 13 and extend it upward on the center-of-front. Make a short sweep at  $\frac{1}{2}$  inch above the measure for depth-of-gorge. Place the width of the top of the backpart again at 13 and apply the meas-

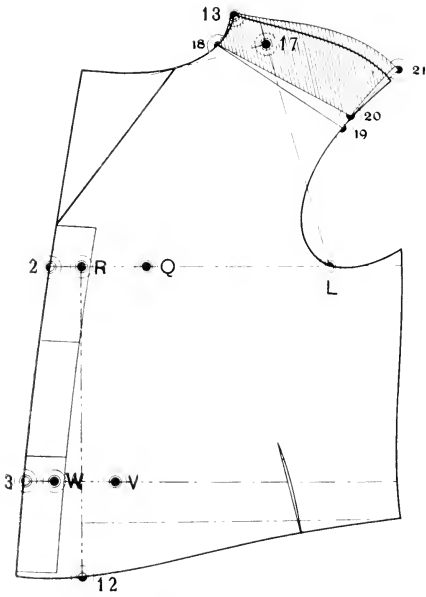

Diagram 16.

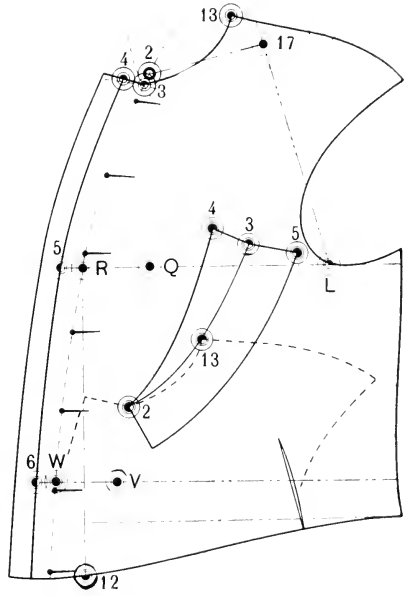

Diagram 17.

ure for half-size of neck and  $\frac{3}{4}$  inch more along the line of the gorge to a point on the first sweep-line as at 3. The intersection of the two measures establishes 3.

From 3 to 4, R to 5 and W to 6 are each  $\frac{3}{4}$  inch.

The line 4, 5, 6, is the edge of the left forepart. Add  $\frac{3}{4}$  inch forward of this for the edge of the right forepart.

**The Collar.** Draw the crease-line from 2 through 13 as represented.

From 2 to 3 is the same as the neck-gorge (3 to 13 and top of backpart, A to H). From 3 to 4 is  $1\frac{1}{4}$  inch. From 3 to 5 is the fashionable width. Shape as represented.

For a standing or military collar see Diagram 29.

## FROCK-COAT SKIRT.

(Regular Form.)

### Diagram 18.

**T**HIS skirt will hang plain at the sides.

### To Draft.

Square the lines AB and AC.

Lay the sidebody as represented and mark by it from A to D.

Lay the forepart as represented, with the fashionable waist line directly over the line AB. Mark along the edge of the pattern from D to the lapel-seam edge at F.

Lay the lapel as represented, overlapping the forepart  $\frac{1}{2}$  inch as from F to E. Mark by it from F to G.

Square downward from G by the fashionable waist line.

A to C is 9 inches.

When the seat is 5 inches larger than the waist, C to J is  $2\frac{1}{2}$  inches (the seat taken close, as for trousers). For example: Take a form of 36 waist and 41 seat. The difference is 5 inches. One-half of 5 is  $2\frac{1}{2}$  and this is the distance from C to J. This is for skirts that are to be **French pressed**. When plain-pressed then C to J is  $\frac{1}{4}$  inch less than as above stated.

Draw a straight line from A  $\frac{1}{2}$  inch forward of J.

A to R is 24 inches. R to T is 1 inch.

Shape the crease-edge by a curved line from A through J towards T.

A to L is  $\frac{1}{4}$  inch more than the length of the back-skirt.

G to M is the same as A to L.

Reduce the top round on the waist-seam  $\frac{1}{4}$  inch below the line of the forepart forward of D as represented.

Add 1 inch backward of AJ and L for the plait.

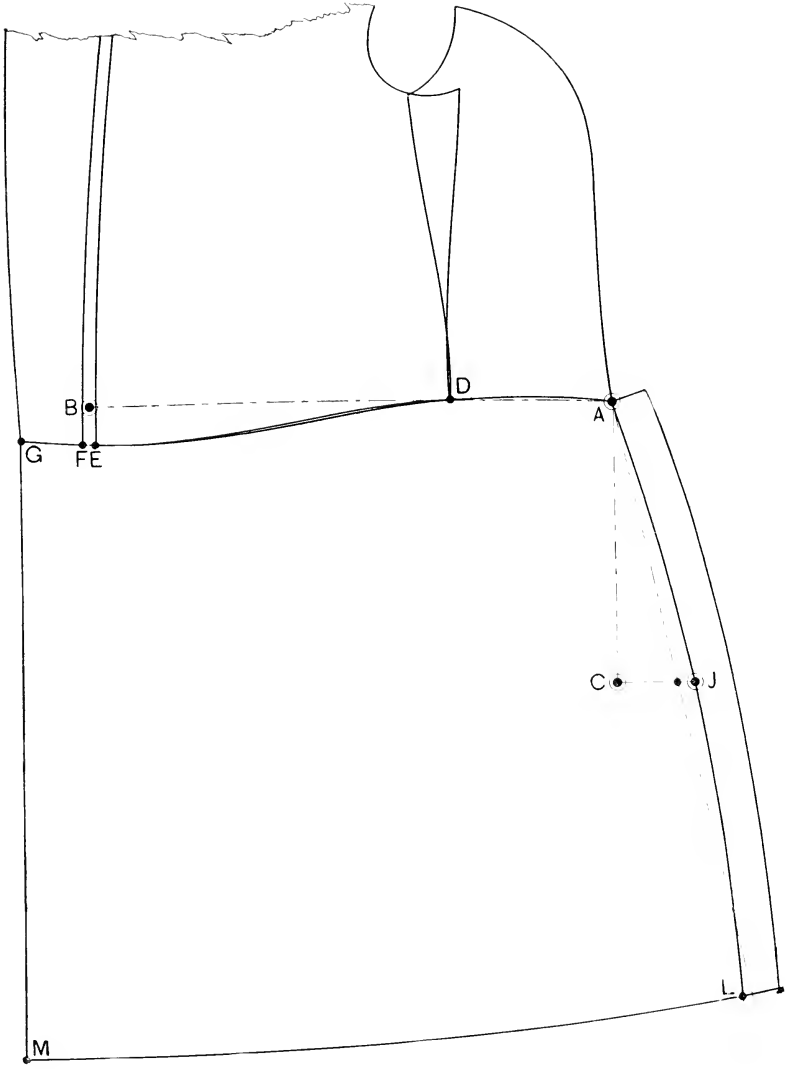

Diagram 18.

T. R.

## FROCK-COAT SKIRT.

(Corpulent Form.)

### Diagram 19.

**T**HIS skirt will hang plain at the sides.

#### To Draft.

Square the lines AB and AC.

Lay the pattern of the sidebody as represented and mark by it from A to D.

Lay the pattern of the forepart as represented, with the fashionable waist line directly over the line A B. Mark along the edge of the pattern from D to the dart at H, make a mark at H.

Pivot at the top of the dart and swing the pattern of the forepart until the front edge of the dart is at H. Then mark from H to the lapel seam edge at F.

Lay the pattern of the lapel as represented, overlapping the forepart  $\frac{1}{2}$  inch as from F to E. Mark by it from F to G.

Square downward from G by the line AB.

A to C is 9 inches.

When the seat is less than 5 inches larger than the waist, proceed as follows:

C to K is  $2\frac{1}{2}$  inches. K to J is as many quarters of an inch as the difference between the waist and seat is less than 5 inches. For example: Take a form of 42 waist and 45 seat (the seat taken close as for trousers). The difference, 3 inches, is 2 inches less than 5. Therefore from K to J is 2 quarters, or  $\frac{1}{2}$  inch.

Draw a straight line from A  $\frac{1}{2}$  inch forward of J.

A to R is 24 inches. R to T is  $\frac{1}{2}$  inch.

Shape the crease-edge by a curved line from A through J on a line which if extended would pass through T.

A to L is  $\frac{1}{4}$  inch more than the length of the back-skirt.

G to M is the same as A to L.

Add 1 inch backward of A J and L for the plait as represented.



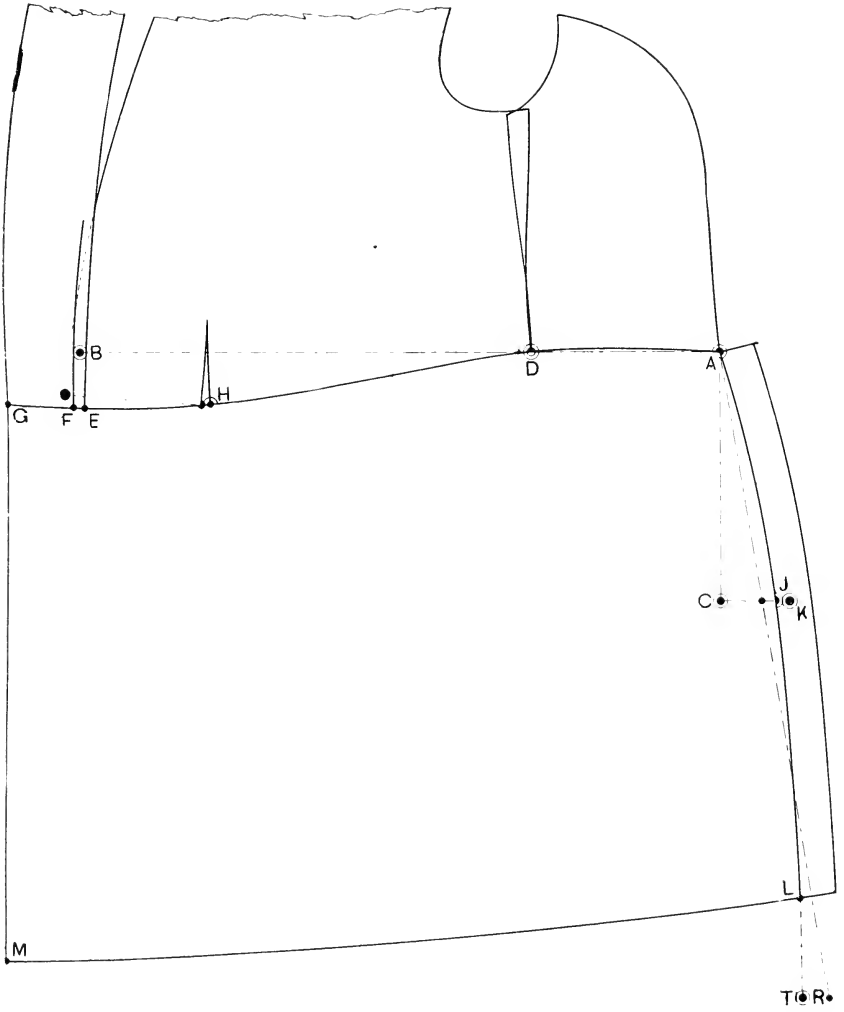

Diagram 19.

## FROCK-COAT SKIRT.

(Extra Drapery.)

### Diagram 20.

**F**OR a skirt with more drapery, or less plain at the sides than as on Diagrams 18 and 19, proceed as follows:

Square the lines A B and A C.

Lay the sidebody as represented and mark along the lower edge from A to D.

Lay the forepart as represented, with the fashionable waist directly over the line A B. Mark along the lower edge of the pattern from D to the lapel-seam which is at F.

Lay the lapel as represented, overlapping the forepart  $\frac{1}{2}$  inch, and mark from F to G.

Square downward from G by the line A B.

I is half-way from A to G. I to X is  $\frac{1}{2}$  inch, more or less.

Shape the waist-seam from A through X to G as represented.

A to C is 9 inches.

When the seat is 5 inches larger than the waist, C to J is  $2\frac{1}{2}$  inches (the seat taken close as for trousers). To this  $2\frac{1}{2}$  inches must be added whatever is taken off at the waist-seam from I to X.

For example: Take a form of 33 waist and 39 seat. The seat is 6 inches larger than the waist and in such case C to J is  $2\frac{1}{2}$  inches and  $\frac{1}{4}$  inch more for each inch that the difference between the waist and seat is more than 5 inches, plus the quantity between I and X,  $\frac{1}{2}$  inch. This gives  $3\frac{1}{4}$  inches in all from C to J in this case ( $2\frac{1}{2}$  plus  $\frac{1}{4}$  and  $\frac{1}{2}$  equals  $3\frac{1}{4}$ ).

G to P is the same as G to X. P is as much forward of the line G M as X is below I. Shape the front from G through P.

Draw a straight line from A  $\frac{1}{2}$  inch forward of J. A to R is 24 inches. R to T is 1 inch. Shape the back crease-edge from A by a curved line through J towards T.

A to L is  $\frac{1}{4}$  inch more than the length of the back-skirt. G to N is the same as A to L.

Add 1 inch for the plait backward of A, J and L.

When the seat is **less than 5 inches** larger than the waist, proceed as above explained with the following exceptions, viz:

R to T is  $\frac{1}{2}$  inch. C to J is  $2\frac{1}{2}$  inches plus the amount between I and X, minus as many quarters of an inch as the difference is less than 5 inches. For example: Take a form 42 waist and 43 seat (the seat taken close as for trousers). The difference in that case is 4 inches less than 5. Therefore

C to J is  $2\frac{1}{2}$  inches plus the quantity between I and X,  $\frac{1}{2}$  inch, which gives 3 inches, minus 4 fourths or 1 inch, which gives 2 inches in all.

When more drapery at the sides is desired increase the amount to be taken from the waist-seam from I to X, and proceed in all respects as above explained.

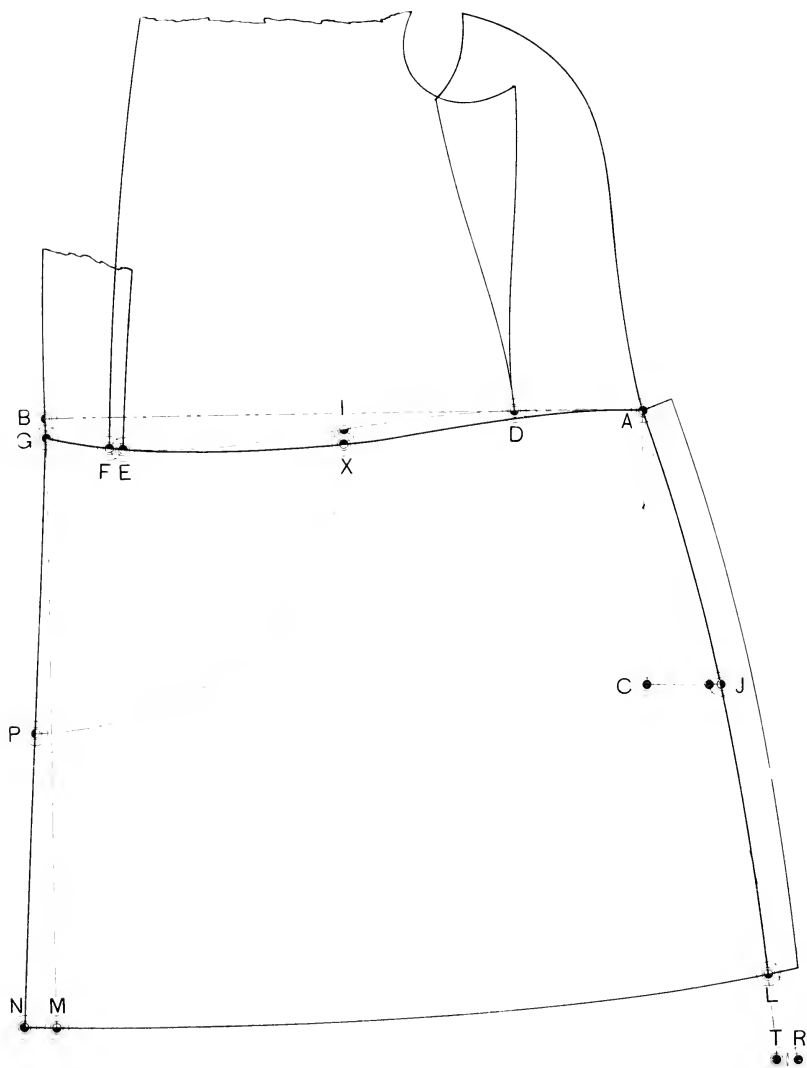

Diagram 20.

## DRESS-COAT.

(Regular Form.)

### Diagram 21.

**T**HE measures used for this diagram are as follows, viz.: 37 breast, 33 waist,  $7\frac{1}{4}$  half-back width,  $9\frac{1}{8}$  back-scye depth,  $16\frac{1}{4}$  natural waist,  $18\frac{1}{2}$  fashionable waist,  $11\frac{1}{4}$  blade,  $12\frac{5}{8}$  front-scye depth,  $17\frac{3}{8}$  over-shoulder, 8 back-waist,  $16\frac{3}{4}$  arm-scye.

### To Draft,

All the points on the back part, except O, all on the sidebody and forepart except 2, 12, 18, 21, R and W are obtained in the same manner as explained for Diagram 14.

O and 2 are obtained as explained for Diagram 15.

Point 12 is 2 inches below the fashionable waist-line, or to style.

Point 18 is 1 inch below 2, or to style.

Q to R is  $2\frac{1}{2}$  inches when the lapel-seam terminates at R, and  $2\frac{3}{4}$  inches when it extends to the gorge.

V to W is 1 inch. The coat is not to button, the front edges of the lapels just meeting at the waist.

The position of the lapel-seam at the breast-line is governed wholly by style-effect desired. For a form having a small waist it may be shaped from W by a graceful curve passing somewhat backward of R and 2. For a corpulent form it may be shaped from W forward of R towards 2.

When the foreparts are to be silk-faced the lapel-seam should not extend above the lapel crease-line. Otherwise it may be continued to 18 if so desired.

Draw a straight line from R 1 inch forward of W for the lapel-seam edge.

R to 21 is the same as R to 12 and  $\frac{1}{2}$  inch less than the width of the skirt strap (F to G, Diagram 22).

The lapel is  $2\frac{1}{4}$  inches wide opposite 12, 3 inches opposite R and  $2\frac{1}{2}$  inches at the top, all of which is, however, governed by taste or style.

Establish the lower buttonhole opposite the waist-seam and those above as represented.

Draw the lapel-crease-line from the end of the roll towards a point  $\frac{3}{4}$  inch forward of 13 to establish 22.

**The Collar.** Draw the crease-line from 22, passing  $\frac{1}{2}$  inch forward of 13, and shape the seam-edge from 18 towards 24, which is  $1\frac{1}{4}$  inch below the collar-crease-line.

From 18 to 24 is the same as the gorge (A to H and 13 to 18).

Square upward from 24 by the line 22 to 23 to establish 23.

From 23 to 25 is the fashionable width. Shape as represented.

For the skirt for this body see Diagram 22.

(On Diagrams 23 and 24 is shown another style of Dress Coat.)

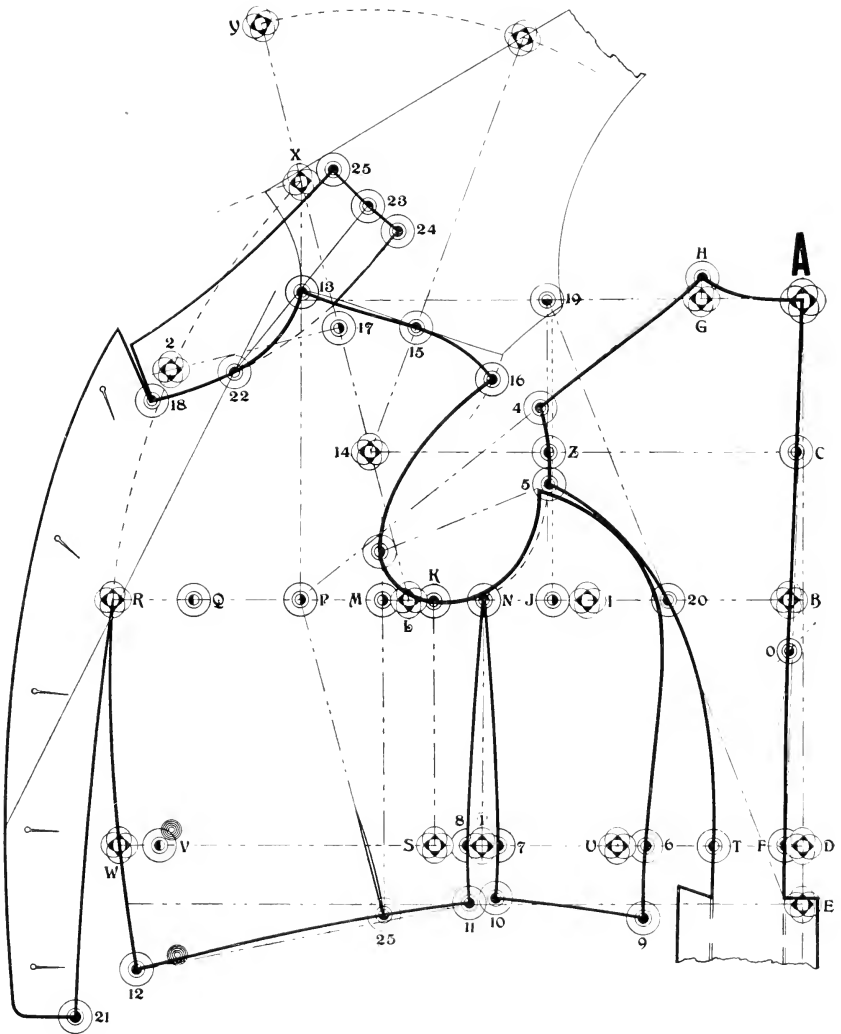

Diagram 21.

## DRESS-COAT SKIRT.

### Diagram 22.

**S**QUARE the lines AB and AC.

Lay the sidebody as represented and mark by it from A to D.

Lay the forepart as represented, with the fashionable waist line directly over the line A B, and mark by it from D to E.

E to F is 1 inch. I is half-way between A and E. Shape from I to F as represented.

Lay the forepart in closed position with the skirt (E and F) and mark from F towards G in line with the front of the forepart.

F to H is  $\frac{1}{3}$  of the width from F to A. F to G and H to K are each  $1\frac{3}{4}$  inch.

A to C is 9 inches.

When the seat is 5 inches larger than the waist, C to J is  $\frac{1}{2}$  inch less than one-half of the difference between the waist and seat (the seat taken close as for trousers).

For example: Take a form of 33 waist and 38 seat. The difference is 5 inches, and  $\frac{1}{2}$  inch less than one-half of this is 2 inches. So that, in this case, C to J is 2 inches.

**Add to this 2 inches**  $\frac{1}{4}$  inch more for each inch that the difference between the waist and seat is **more than 5 inches**, and **deduct from 2 inches**  $\frac{1}{4}$  inch for each inch that the difference is **less than 5 inches**.

Draw a straight line from A  $\frac{1}{2}$  inch forward of J.

A to R is 24 inches. R to T is  $3\frac{1}{4}$  inch. Shape the back edge by a curved line from A through J towards T.

A to L is  $\frac{1}{4}$  inch more than the length of the back-skirt.

Sweep forward from L, pivoting at A.

L to M is the same as F to H, **or to style**.

Draw an outward curved line from H to M and shape the front as represented.

Add 1 inch for the plait backward of A J and L as represented.

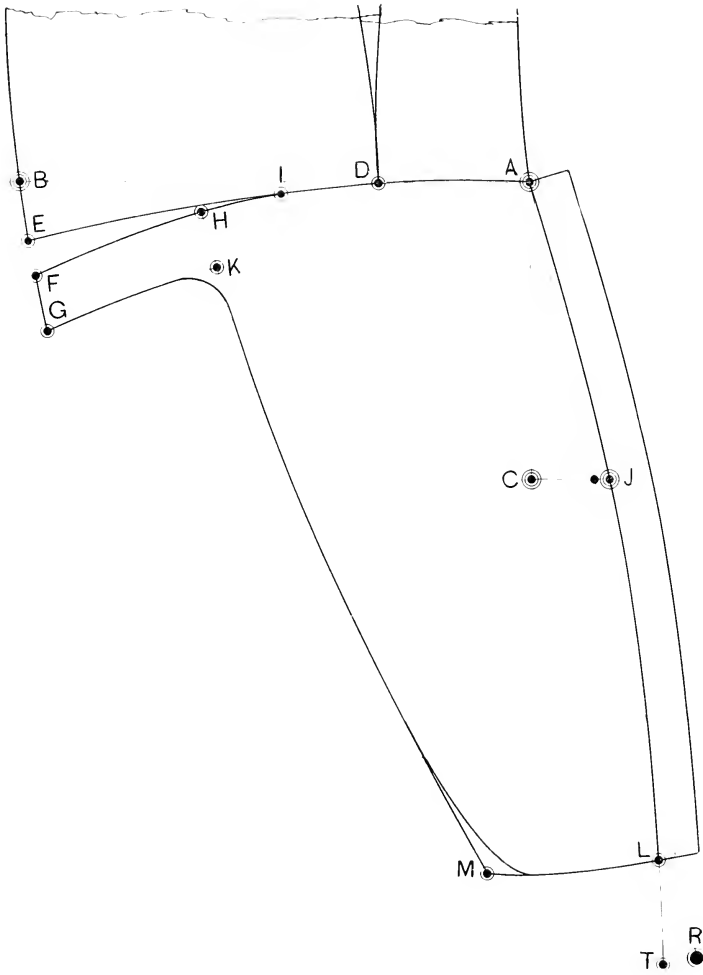

Diagram 22.

## DRESS-COAT.

### Diagram 23.

**T**HE measures used for the accompanying diagram are as follows, viz.: 40 breast, 42 waist, 9 back-scye depth, 17 natural waist, 18 fashionable waist,  $7\frac{1}{2}$  half-back width, 12 blade,  $13\frac{1}{2}$  front-scye depth, 18 over-shoulder,  $9\frac{3}{4}$  back waist,  $17\frac{1}{8}$  arm-scye.

### To Draft,

Square the lines A E and A 19.

Obtain the lengths to B, C D and E, also the full-length as heretofore explained, and square forward from each.

All the points on the backpart except T are found in the same manner as heretofore explained. F to T is  $\frac{1}{4}$  inch less than  $\frac{1}{8}$  breast.

Obtain all the points on the breast-line except N and R as heretofore explained. Q to R is  $2\frac{3}{4}$  inches. N is half-way from J to K. Square downward from N, K and R. Square upward from M and P.

L to X is  $\frac{3}{4}$  inch more than the front-scye depth, and on to Y is  $\frac{3}{4}$  inch more than the over-shoulder. Sweep forward from X, pivoting at L and backward from Y, pivoting at 14.

X to 17 is  $\frac{1}{4}$  breast. Square forward from 17.

Finish the back-skirt as explained for Diagram 5, cut out the backpart and lay it in the position shown on the upper part of the diagram. Point H is on the line which is squared upward from P, A is on the sweep line from X and B on the sweep-line from Y.

Place a weight on the back, mark lightly along the back shoulder seam, mark point B and shape the gorge towards 24. This establishes 13.

Draw a straight line from B to 14. This establishes 15.

Shape the front-shoulder seam of the forepart from 16, which is about  $\frac{3}{4}$  inch below the outer shoulder point (4) on the backpart, through 15 and 2, which is at the hollow of the back shoulder seam where the line from L to Y crosses it, to 3. This formation should govern in the formation of **all front shoulder seams** when any hollow is given to the back-shoulder



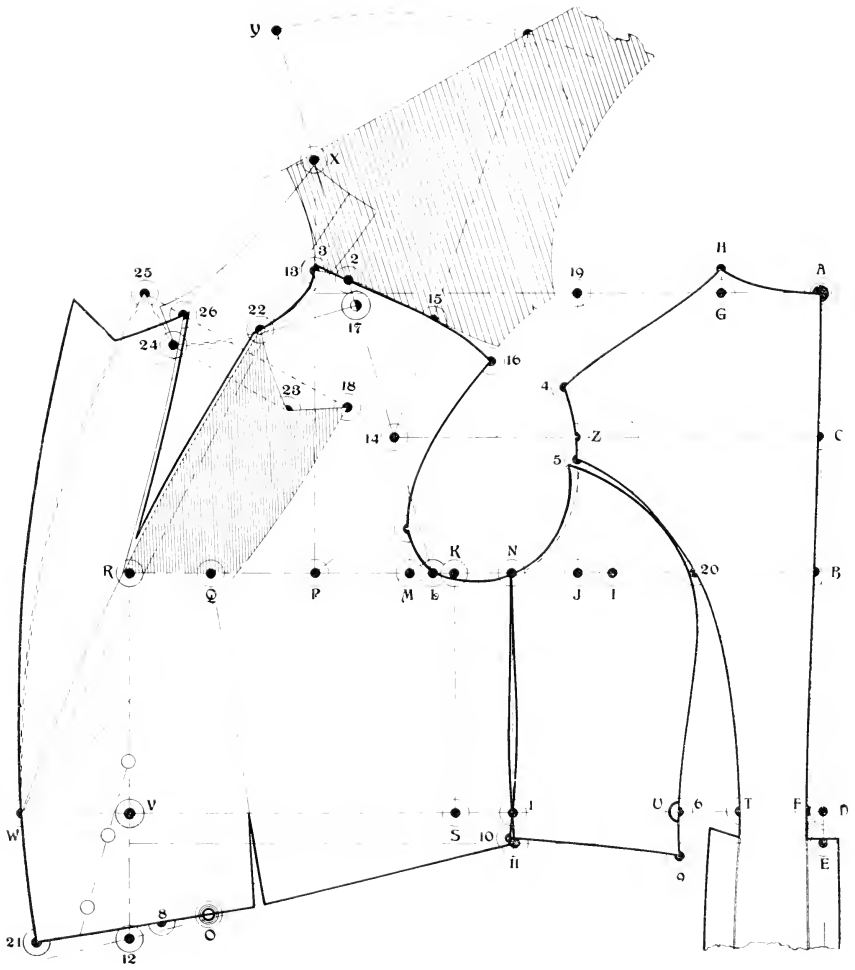

Diagram 23.

seam as in this case. Nothing must be lost on the line from L to Y at 2. This establishes 3 a trifle, about  $\frac{1}{4}$  inch, above 13.

S to U is the back-waist less the width of the backpart from F to T.

F to T and U to V is a full half of the waist, 21 inches. V to W is 3 inches.

T to 6 is 2 inches. In this case U and 6 are at the same place and there is therefore nothing to be taken out at point 1. Shape the sidebody from  $\frac{3}{8}$  inch forward of 5, passing  $\frac{1}{4}$  inch forward of 20 through 6 toward 9 and the front edge from N through 1, as represented.

From 20 to 9 is  $\frac{1}{4}$  inch more than from 20 to the fashionable waist line on the sideseam of the backpart. Point 10 is  $\frac{1}{4}$  inch above the fashionable waist line.

Point 12 is 3 inches below the fashionable waist line. Draw a straight line from 11 through 12, and for corpulent forms, square upward from this line towards Q. (For forms not corpulent omit the dart on the waist seam and substitute the fish as explained for Diagram 21.)

Make the dart  $\frac{1}{16}$  inch wide for each inch that the waist is more than a waist 4 inches smaller than the breast, as for example: A waist 4 inches smaller than this breast of 40 inches is 36 inches. As the waist in this case is 42 inches it is 6 inches larger than 36, and the dart is therefore  $\frac{6}{16}$  inch wide.

From the dart to 8 is the same as the height of the dart, and it is as much above the line from 11 through 12 as the width of the dart. Extend the waist-seam forward of the dart through 8 as represented.

Shape the front edge from the waist-line to the bottom and draw a straight line from the end of the roll towards a point  $\frac{3}{4}$  inch forward of 13. Draw another line between the same points, rounding out  $\frac{3}{4}$  inch forward of the straight line opposite R.

Establish 18 and 23 according to style, and shape the lapel from the end of the roll to 18 and 23.

Square forward by the crease-line from 18 and 23. From the crease-line to 24 is the same as to 23, and from the crease-line to 25 is the same as to 18. Shape the gorge from 13 to 24 and the lapel from 24 to 25 and from 25 to the end of the roll as represented by the chain-stitch lines.

Make a tracing of the part of the lapel above the breast-line and forward of the crease-line below 22. Cut this out, lay it on top of the draft, and, pivoting it at the intersection of the breast and crease lines, swing the upper part forward 2 inches, as from 22 to 26. Mark around the piece from the breast-line to 26, across the top and from there to the end of the roll as represented.

Cut out the dart adding a seam forward of 22 and backward of 26 as represented.

**The collar** should be drafted as soon as the gorge has been shaped. Extend the crease-line above 22, make the stand  $1\frac{1}{8}$  inch wide and the seam-edge the same as the neck (A to H and 3 to 24). Make the back end of the stand square with the crease-line and the end of the leaf a trifle backward of a line square from the crease-line. The leaf is  $1\frac{1}{2}$  inch wide at the back and  $1\frac{1}{4}$  inch at the front.

From 21 to O is one-third of the distance from 21 to 9.

For the skirt for this body see Diagram 24.

## DRESS-COAT SKIRT.

### Diagram 24.

**T**HIS skirt is only applicable to Dress-Coat Bodies drafted as shown on Diagram 23.

The lower part of the forepart and sidebody are shown and the line from 9 to B represents the fashionable waist line. This is the same line as is squared forward from E on Diagram 23.

Draw another line  $1\frac{1}{2}$  inch below the fashionable waist line and parallel with it as the line A Z.

From 21 to 0 is  $\frac{1}{3}$  of the distance from 21 to 9.

From 11 to I is  $\frac{1}{6}$  waist.

From O to A is the same as from O to 11, 10 and 9 less the width of the dart.

Connect A and I and square downward by this line from A.

A to C is 9 inches. Square backward from C.

C to J is 2 inches when the seat is 5 inches larger than the waist,  $\frac{1}{4}$  inch less than 2 inches for each inch that the difference between the seat and waist is less than 5 inches, and  $\frac{1}{4}$  inch more than 2 inches for each inch that the difference is more than 5 inches.

Draw a straight line from A through the unlettered point  $\frac{1}{2}$  inch forward of J.

A to R is 24 inches.

R to T is  $\frac{1}{2}$  inch.

Shape the crease-edge from A, rounding through J and continuing on through T.

A to L is  $\frac{1}{4}$  inch more than the back-skirt.

Pivot at A and sweep forward from L.

L to M is 1 inch more than  $\frac{1}{3}$  breast.

Connect M and O as a guide and shape as represented.

Add 1 inch backward of A J L for the plait as represented.

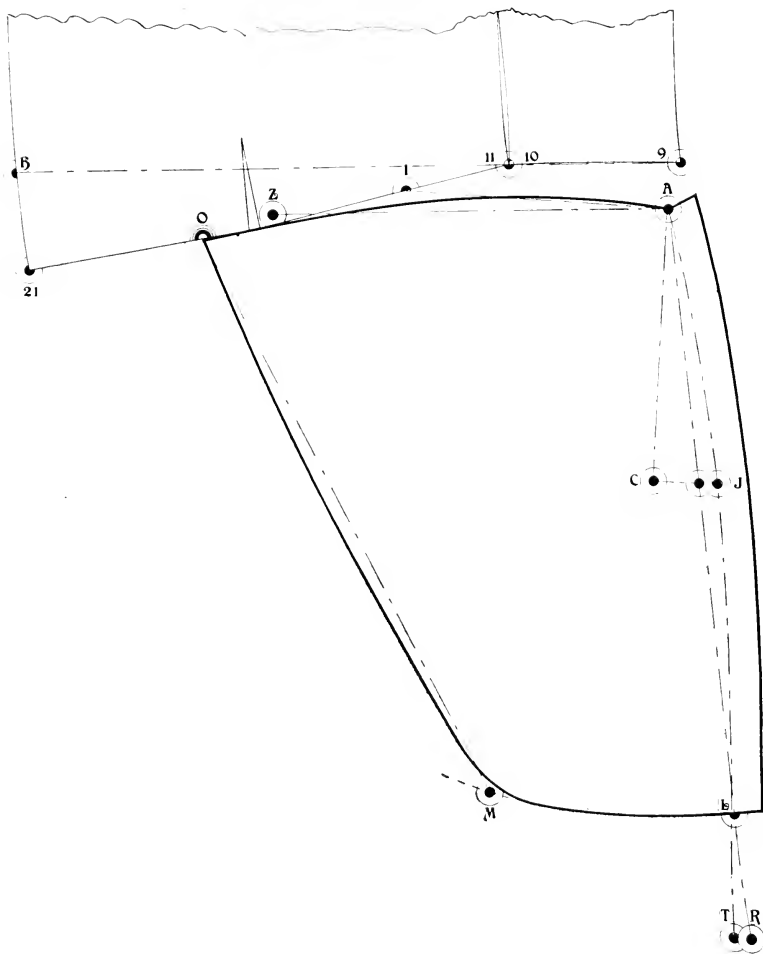

Diagram 24.

## SINGLE-BREASTED SACK-COAT.

### Diagram 25.

**T**HE measures used for the accompanying diagram are as follows: 36 breast, 32 waist, 37 seat, 7 half-back width,  $8\frac{1}{2}$  back-scye depth,  $16\frac{1}{2}$  natural waist,  $24\frac{1}{2}$  seat-line, 29 length, 11 blade,  $12\frac{3}{8}$  front-scye depth, 17 over-shoulder,  $7\frac{3}{4}$  back-waist,  $16\frac{1}{2}$  arm-scye.

### To Draft.

Square the lines A E and A 19.

Place the end of the tape-measure  $\frac{1}{4}$  inch below A, and mark the back-scye depth at B, the natural waist at C, the seat-line at D, and  $\frac{1}{4}$  inch more than the length at E.

B to 1 is one-half of the back-scye depth. Square forward from each of these points.

C to F is  $\frac{1}{2}$  inch. Connect A and F and shape the center-of-back from A through F to  $\frac{1}{4}$  inch forward of E as represented.

B to K is the blade. K to M is  $1\frac{1}{2}$  inch. L is half-way between K and M.

K to P is  $1\frac{1}{4}$  inch more than  $\frac{1}{6}$  breast. B to Q is a full half of the breast. Q to R is  $2\frac{1}{2}$  inches.

R to 2 is  $1\frac{1}{4}$  inch when the edge is stitched and 1 inch when it is bound.

Square downward from K to establish S. Square upward from M and P.

I is half-way from B to M. I to J is  $1\frac{1}{4}$  inch.

To obtain the natural half-back width square upward from J.

From 1 to Z is  $\frac{1}{2}$  inch more than the fashionable or measured half-back width. Square upward and downward from Z. (In this case the natural and measured widths are the same.)

A to G is  $\frac{1}{6}$  breast. G to H is  $\frac{1}{24}$  breast. Connect H and P.

Shape the scye as represented, from 4 to the front-scye notch, which is at the unlettered point  $1\frac{1}{2}$  inch above M. Connect 1 and M to establish 5.

Square downward from I to establish T.

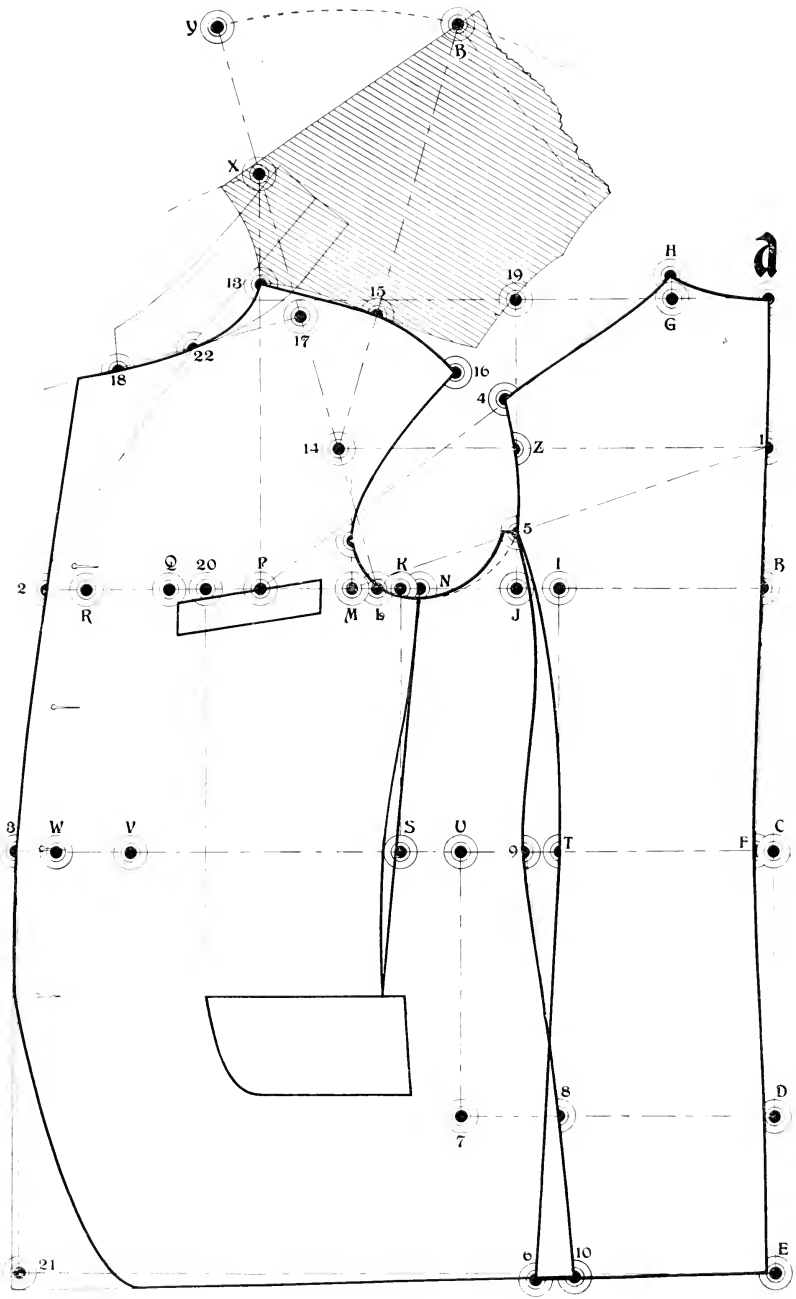

Diagram 25.

E to 6 is  $\frac{3}{4}$  inch more than C to T. Shape the side-back as represented below 5 through T to 6.

Obtain points X, Y, 14, 17, and shape the front-shoulder in the same manner as explained for Diagram 23.

F to T and S to U is the back-waist. F to T and U to V is a full half of the waist. V to W is  $2\frac{1}{4}$  inches. W to 3 is the same as R to 2.

Square downward from U to establish 7.

When the waist is 5 or more inches smaller than the seat, from 7 to 8 is 3 inches. (See Diagram 30 for corpulent forms.)

The quantity between T and U represents a surplus through that part (3 inches for this draft), more than the measurement for the back-waist. As much of this surplus may be taken out between T and 9 and in the fish under the arm as required or **according to style**. On the diagram T to 9 is  $1\frac{1}{4}$  inch, and the fish is  $\frac{1}{2}$  inch wide. K to N is  $\frac{1}{2}$  inch.

Shape the sideseam from 5 about  $\frac{1}{8}$  inch forward of J through 9 and 8, and the fish as represented. In case the fish is not required, shape the side seam as is explained for Diagram 27.

From 9 to 10 is the same as T to 6. Shape the bottom from 10 towards a point  $\frac{1}{2}$  inch, more or less, below 21, according to style.

Apply the arm-scye as explained for Diagram 4.

Shape the front above and below the end of the roll all **according to style**, and draw the crease-line from  $\frac{1}{2}$  inch forward of 13 to the end of the roll. This establishes 22.

The buttons are placed  $1\frac{1}{2}$  inch from the front edge.

M to 20 is  $\frac{1}{4}$  breast. Square downward from 20 to locate the front of the pocket mouth.

The collar is drafted in the same manner as explained for Diagram 30.



## SINGLE-BREASTED SACK-COAT.

### Diagram 26.

**A** NOTHER style of 3 button sack-coat is shown on this diagram. The back part and all the points on the forepart excepting 18, 19, 20, 24, 25 and 26 are obtained in the same manner as explained for Diagram 25.

The broken line from 2 through 3 represents the front edge when the fronts close with three buttons all placed  $1\frac{1}{2}$  inch from the front edge. In this case the fronts are slightly cut-away below the top button, and for this reason the buttons are placed as much less than  $1\frac{1}{2}$  inch from the edge, as the front has been shaped inside the line from 2 through 3.

Draw the rever crease-line from  $\frac{1}{2}$  inch forward of 13 to the end of the roll, which must be established **according to style**.

As the height of the gorge, length of collar and shape of the rever are governed by style, which is constantly changing from

season to season, these matters can easily be determined by proceeding in the following manner: Having first established the front edge below the top button and the height of the top button on or above or below the breast-line, in conformity with a careful view of the fashion-plate, then draw the crease-line from the end of the roll towards a point  $\frac{1}{2}$  inch forward of the front-shoulder point, 13.

Next establish the point of the rever, 18, its height in relation to the breast-line and neck. On the fashion-plate from which this style was selected the point of the rever appears to be a little more than half-way from the breast-line to the neck, and the height is so established on the draft. (The neck-height is found by drawing a light line parallel with the breast-line as from point 18 on Diagram 25, or where the line which is squared forward from 17 engages the center-of-front. It is shown on this diagram by a dotted line lettered G. The dotted line lettered H is half-way between the neck-line and breast-line.)

Having established the height of point 18, consult the fashion-plate and determine the **width** of the rever. It appears to be a trifle less than half the width of the front from the crease-line to the front-of-scye, and is so established on the draft.

Next establish point 23 in its relation to point 18, and square across from 18 and 23 by the crease-line.

From the crease-line to 24 is the same as to 23, and from the crease-line to 25 is the same as to 18.

Now reshape the gorge to 24 and the rever from 24 to 25 and to the end of the roll (as represented by a chain-stitch line).

Draft the collar as represented, and as has been repeatedly explained.

Draw a straight line from Q about 1 inch backward of 24 as to 20.

Place a piece of paper underneath the draft and make a tracing of the part from Q to 20, 24, 25, and to the end of the roll. Mark point Q on the traced piece and cut the piece out.

Now, holding the piece at Q, swing the upper part forward 1 inch as from 20 to 26, and mark around it. This gives the heavy lines forward of 26. Shape from the point of the rever to the end of the roll, connect 26 and Q, and cut out the dart, adding a seam's width forward of 20 and backward of 26.

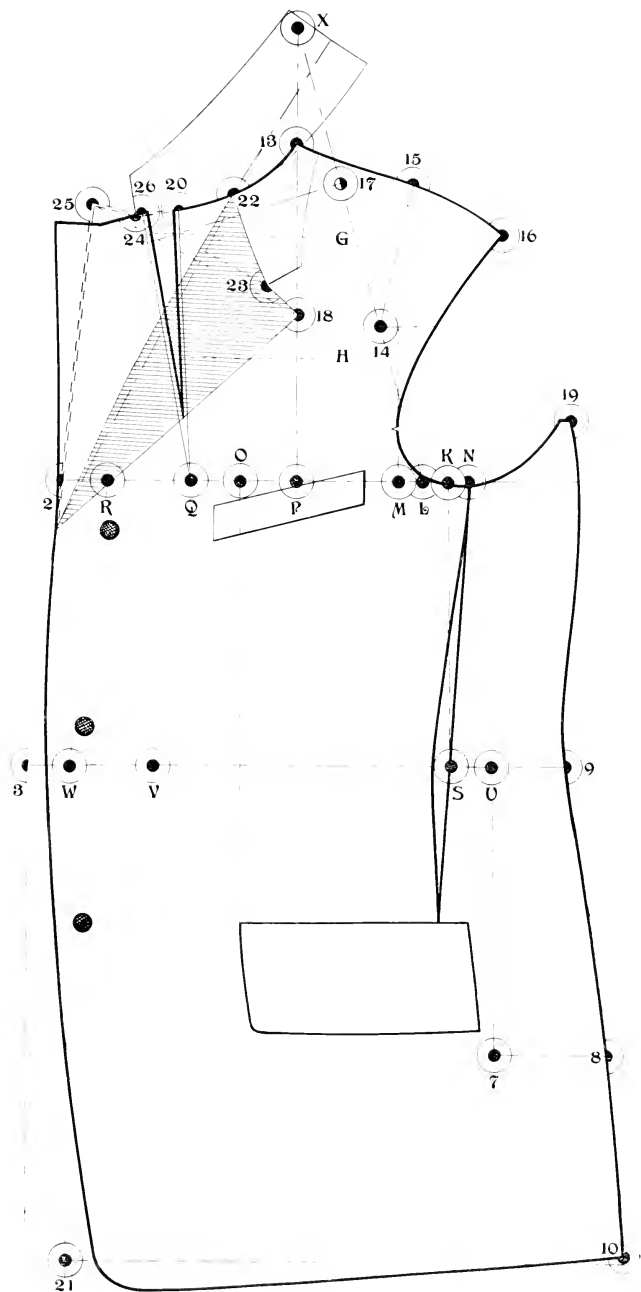

Diagram 26.

## LONG ROLL SACK-COAT.

### Diagram 27.

**A** NOTHER style of sack-coat is shown on this diagram. It is to button at one button only, which is at the end of the roll, and for this reason the matter of **size in front is only important at the point where the coat buttons.** The front edge is therefore kept on the line below 3. All above the end of the roll is a matter of style which can easily be obtained in the following manner:

For a long-roll coat, draw a light straight line from  $\frac{3}{4}$  inch forward of 13 to the end of the roll, and another one between the same points, but rounding forward of the straight line  $\frac{1}{2}$  inch at the breast-line.

Establish 18 and 23, 24 and 25 in the same manner as explained for the preceding diagram. Draft and cut out the collar.

Place paper underneath and make a tracing of the part above the breast-line and forward of the crease-line (22). Place the traced piece on the draft, and, holding it at the breast-line, swing the upper part forward 1 inch, as from 22 to 26. Mark around it to the point of the rever; shape from the point of the rever to the end of the roll and connect 26 and the breast-line where it intersects the crease-line as represented.

Cut out the dart, adding a seam's width forward of 22 and backward of 26.

All the remaining points excepting Y and 9 are obtained in the same manner as explained for Diagram 25.

As there is no fish taken out under the arm the sideseam of the forepart is reduced two seams, width, or  $\frac{1}{2}$  inch as from 5 to Y, and the bottom of the scye is reshaped as represented. The quantity taken out between T and 9 may be any part of the back-waist surplus (T to U) not exceeding  $\frac{2}{3}$  of it, as desired. When more shapeliness is desired at the back-waist it should be taken out by a fish under the arm, and then the side-seam should be shaped above 9 to 5 on the backpart.

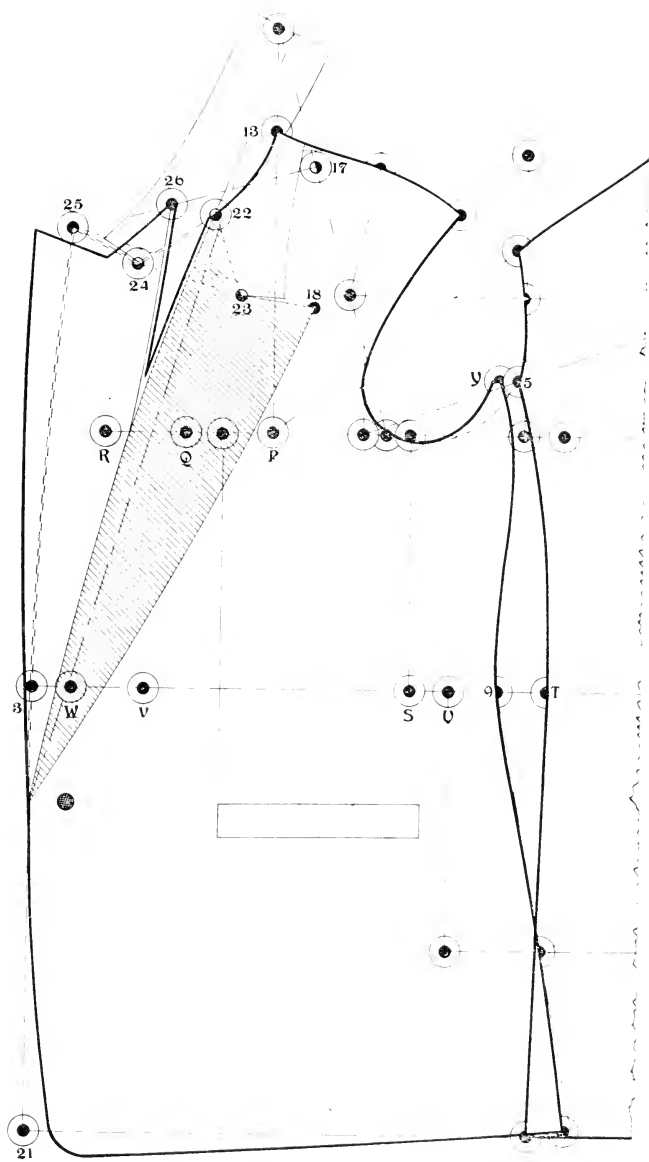

Diagram 27.

## DOUBLE-BREASTED SACK COAT.

### Diagram 28.

**T**HE backpart is drafted in the same manner as explained for Diagram 25.

All the points on the forepart excepting 3, 4, 18, 20, 22, 23, 24, 25, 26, G and H are obtained in the same manner as explained for Diagram 25.

The line R, W, 21 is the center-of-front.

The width of the front forward of the center-of-front line is **governed by style**. For this coat R to 3 and W to 4 are each  $2\frac{3}{4}$  inches. Connect R and W, 3 and 4 by lines curving somewhat forward of straight lines, and establish the position of the buttons and buttonholes **according to style**. Sweep backward from the eyes of the buttonholes, pivoting at the neck and center-of-front (at about the position of point 20) to obtain the height of the buttons. From the center-of-front line to the button-line is  $\frac{3}{4}$  inch less than to the front edge.

Next draw a straight line from  $\frac{1}{2}$  inch forward of 13 to the end of the roll, and another between the same points rounding forward of the straight line about  $\frac{1}{2}$  inch as represented.

Obtain points 18, 23, 24 and 25, also the lines G and H in the same manner as explained for Diagram 26, and shape the gorge from 13 to 24.

Draw a straight line from about the position of 20 to about midway between Q and R. Make a tracing of that part of the rever which is above the breast-line and forward of the line below 20; cut it out and lay it on the draft. Pivot the traced piece at the breast-line below 20, and swing the upper part forward 1 inch as from 20 to 26. Mark from 26 to the point of the rever and shape the front below as represented.

The bottom is usually shaped from the sideseam passing one inch below 21. It may be more or less than 1 inch, **according to style**.

When cutting out the dart add  $\frac{1}{4}$  inch forward of 20 and the same backward of 26, as represented.

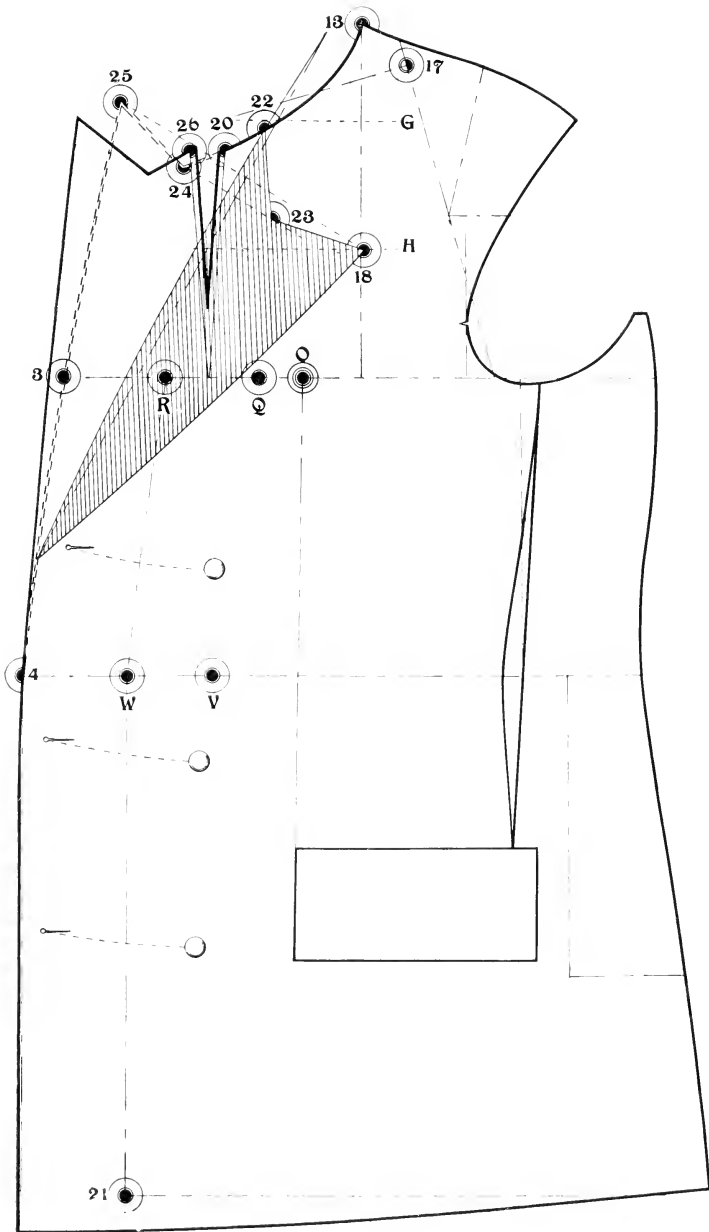

Diagram 28.

## SINGLE-BREASTED UNIFORM JACKET.

### Diagram 29.

**O**N THE accompanying diagram is shown a single-breasted uniform jacket. It closes at the neck and is close-fitting at the back-waist.

The measures used for this draft are for a regular form of 36 breast. The neck is 17 and depth-of-gorge 8.

### To Draft.

Square both ways from the top of the backpart as represented; obtain the back-depth, natural-waist, seat-line, full length and point 1, and square forward from each.

C to F is 1 inch. E to 3 is  $\frac{3}{4}$  inch. Shape the center-of-back seam as represented.

All the points on and above the breast-line excepting 2, 12, 18, 24, 19 and 22 are obtained in the same manner as explained for Diagram 25, excepting that the back-shoulder seam may be drawn a trifle higher by extending the guide-line to Q instead of to P. Connect 1 and P to establish 5.

F to T is  $\frac{1}{4}$  breast.

F to T and S to U is the back-waist.

F to T and U to V is a full half of the waist.

V to W is  $2\frac{1}{4}$  inches.

From 3 to 6 is 1 inch more than F to T.

Shape the side-back from 5 to T and 6 as represented.

Square downward from U to establish 7. From 7 to 8 is 3 inches when the seat is 5 inches larger than the waist, and  $\frac{1}{4}$  inch more or less than 3 inches according as the difference between the seat and waist is more or less than 5 inches.

From T to 9 is two-thirds of the quantity between T and U. Shape from 5 through 9 and 8 as represented, and make U to 10 the same as T to 6. Shape the bottom from 10, passing  $\frac{1}{2}$  inch below 21 (or to style).

Pivot at R and sweep downward from B. Take the same distance that R is from B and, pivoting at X, sweep downward just



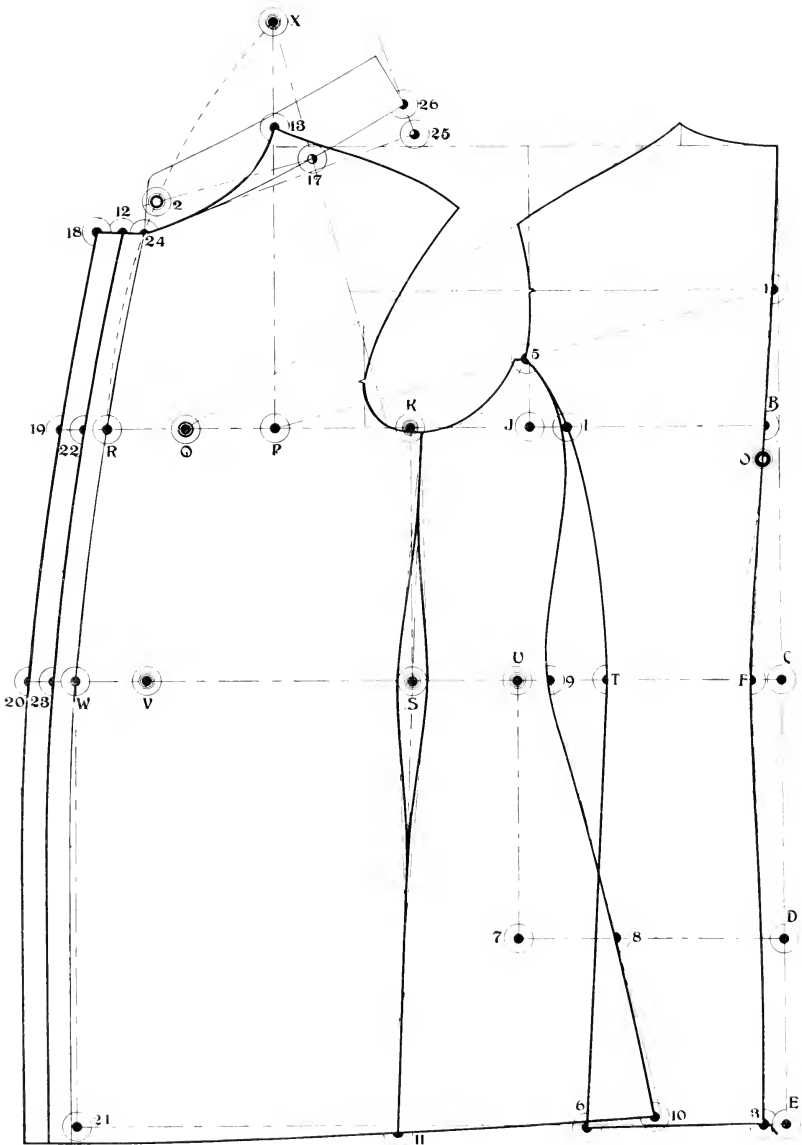

Diagram 29.

below B to establish O. Pivot at O and sweep upward from R to X. This establishes 2.

To establish 24 proceed as follows:

Place the end of the tape-measure at X, extend it to 13 and then to W. Hold it at W, extend it towards 2, and make a short sweep across the sweep-line from R to X,  $\frac{1}{2}$  inch above the measure for depth-of-gorge. (The measure in this case being 8, the sweep is at  $7\frac{1}{2}$ .) Now shape the gorge from 13 to the sweep-line and apply the measure for the half size of neck and  $\frac{3}{4}$  inch more from X through 13, following the gorge to 24.

Shape the center-of-front from 24 through R and W as represented.

From 24 to 18, R to 19 and W to 20 are each  $1\frac{1}{2}$  inch. From 24 to 12, R to 22 and W to 23 are each  $\frac{3}{4}$  inch. The line below 12 represents the edge of the top or buttonhole side. That below 18 represents the edge of the under, or button side.

The line below 24 is the center-of-front and the button line.

Apply the arm-scye measure as explained for Diagram 4.

Draw a straight line from  $\frac{1}{2}$  inch backward of K through S and make the width of the fish at S the same as U to 9.

These coats are sometimes ornamented with wide braid, which is laid (the outer edge) on the center-of-front on each forepart. In which case the front of the left forepart is cut off on the line below 24. The button side is extended  $\frac{3}{4}$  inch beyond 18, 19 and 20, and the line below 12 is the button-line. The fronts close with a fly.

To draft the collar proceed as follows: Draw a straight line as from 24 towards 25. From 24 to 25 is the same as the size of the neck. Square upward from 25. From 25 to 26 is 1 inch. Shape from 26 to 24 as represented.

Square upward from 26, make the width  $1\frac{3}{4}$  inch, and finish as represented.

## SINGLE-BREASTED SACK COAT.

(Corpulent Form.)

Diagrams 30 and 31.

**T**HE measures used for the accompanying diagrams are 46 breast, 48 waist, 49 seat,  $9\frac{3}{4}$  back-scye depth,  $16\frac{1}{2}$  natural waist, 25 seat-line, 29 length,  $8\frac{3}{8}$  half-back width,  $13\frac{1}{2}$  blade,  $14\frac{3}{4}$  front-scye depth,  $19\frac{3}{4}$  over-shoulder,  $11\frac{1}{2}$  back-waist, and 19 arm-scye.

### To Draft.

Diagram 30.—All the points on the backpart are obtained in the same manner as explained for Diagram 25, excepting 4, 5, T and 6. E to 4 is  $\frac{1}{2}$  inch, the same as C to F. Point 5 is obtained by connecting 1 and K. T is obtained by squaring downward from midway between I and J. From 4 to 6 is 1 inch more than F to T.

All the points on and above the breast-line are obtained in the same manner as explained for Diagram 25.

F to T and S to U is the back-waist.

F to T and U to V is a full half of the waist.

V to W is  $2\frac{1}{4}$  inches, W to 3 is the same as R to 2. Square downward from 3 to establish 21.

Square downward from U to establish 7.

From 7 to Y is 3 inches. From Y to 8 is as many quarters of an inch as the difference between waist and seat is less than 5 inches. In this case the difference is 4 inches less than 5, and Y to 8 is therefore 1 inch.

As much of the back-waist surplus (U to T) may be taken out between T and 9 as necessary to **give good form** to the side-seam of the forepart. In this case it is nearly all taken out, for the reason just mentioned, also for the reason that forms of this

class have a flat seat and are not as much hollowed in at the back-waist as other forms. In consequence of this fact if all of the surplus was taken out, the coat would not have too shapely an appearance, because the form is much less hollow-waisted than those having a small waist and large seat.

M to O is 1 inch more than  $\frac{1}{4}$  breast.

Having established the pocket opening draw a straight line from the back of it to a point at about the position of N.

It is evident that if this coat was to button at all of the buttons, the front edge would have to be shaped from opposite the top and bottom buttons on the line from 2 through 3. This would be an awkward looking shape, and should be avoided whenever possible. For forms of this class a coat that buttons at the **top button only** will tend to lessen the appearance of excessive corpulency, and is the most suitable. Maintain the size therefore **at the button which is to be utilized** (the top one in this case). Below that button the front can be cut away as represented or **to taste or style**.

**The collar** is drafted in the following manner:

Extend the crease-line from 22,  $\frac{1}{4}$  inch forward of the front shoulder-point, and made from the shoulder-point to 25 the same as A to H on the backpart.

Square upward and downward by the crease line from 25. From 25 to 26 is  $1\frac{1}{4}$  inch. From 26 to 27 is  $1\frac{1}{2}$  inch. Make the width and shape in front **according to style**, and finish as represented.

Cut out the pattern and on the forepart cut down on the line below N to the pocket and across to the front of the pocket. Then proceed as explained for the next diagram.

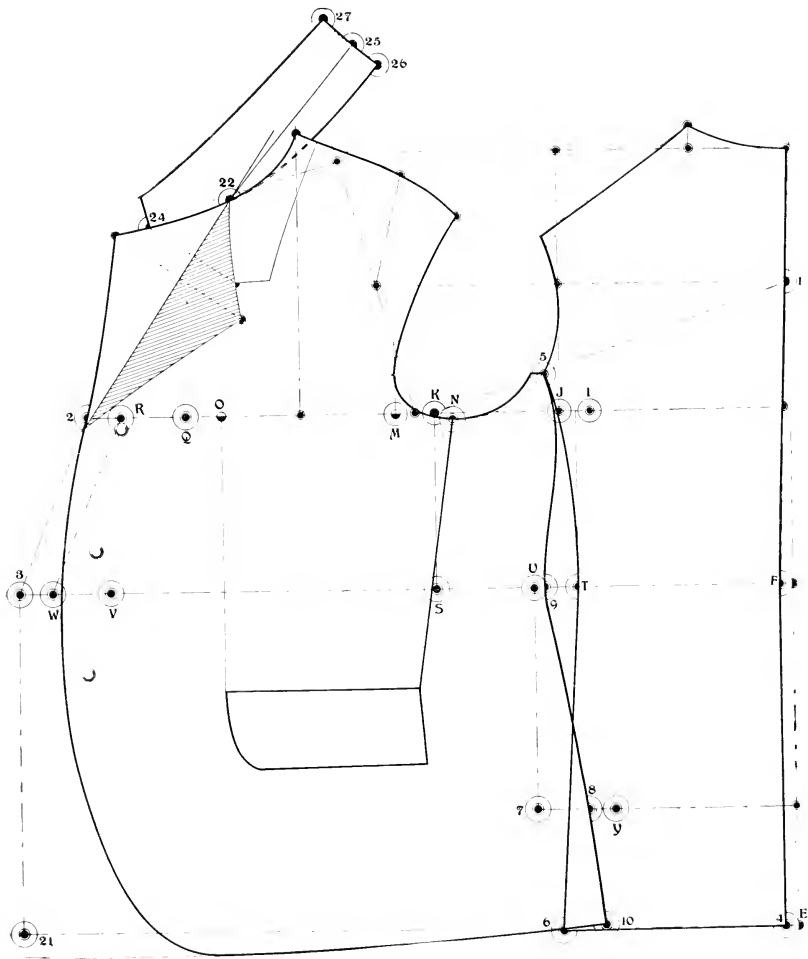

Diagram 30.

Diagram 31.—A separate pattern may be made with the changes to be made in the pattern for the forepart, or the changes can be made on the material, as preferred. In either case mark from opposite the pocket at B up and around the shoulder and scye to the slash which is at N, and then on to C and D. Make a mark at the bottom at the front-length H.

Spread the mouth of the pocket open as from C to E, according to the degree of corpulency. For a form having a waist 2 inches less than breast, make from C to E  $\frac{1}{4}$  inch. When the waist is as large as the breast, spread  $\frac{1}{2}$  inch. When the waist is 2 or more inches larger than the breast, spread  $\frac{3}{4}$  inch.

Mark from D to E, E to F, and down the sideseam to G. Make a cross-mark at G for the side-length; press the fullness flat at B, and mark from B to H.

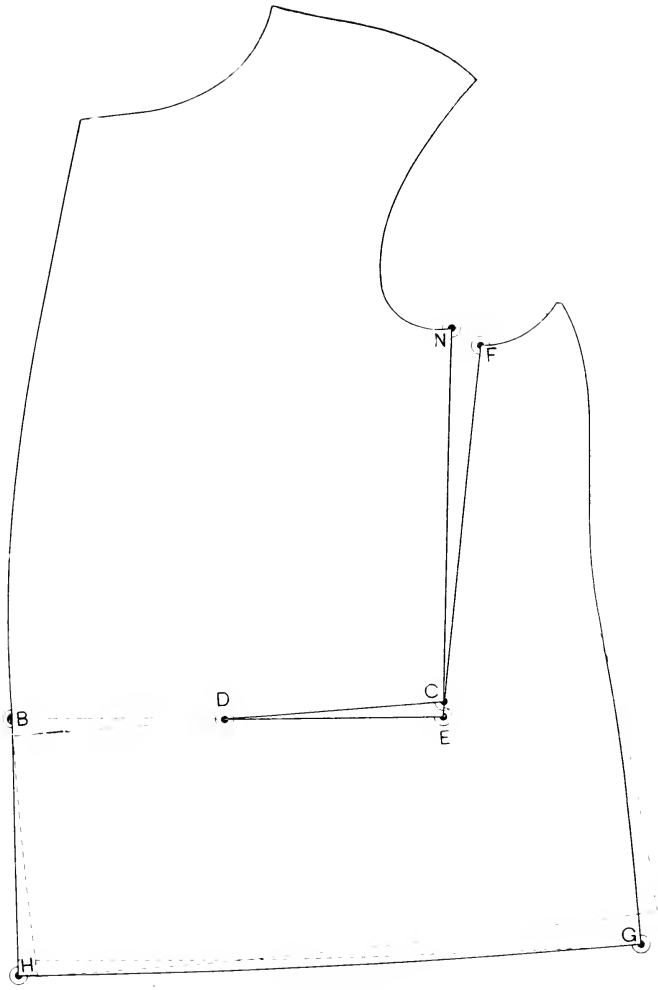

Diagram 31.

## WHOLE BACKS.

### Diagrams 32 and 33.

**D**IAGRAM 32—Draw a straight line as A E.

Establish A; place the end of the tape-measure  $\frac{1}{4}$  inch below it; mark lengths to B, C, D, E and I and square across from each.

Obtain all the remaining points except 2 and 3 as heretofore explained.

Reduce a seam's width forward of A and E as from 2 to 3. When marking on the material the line from 2 to 3 is laid even with the fold of the goods. The material must be well stretched on the sideseam at T and well shrunk at above and below C.

Diagram 33—A back which has been drafted with a shaped center-back seam may be changed to a whole back by laying the back as first drafted over another piece of paper, the top and bottom touching a straight line at A and E as represented.

Also reduce the width  $\frac{1}{4}$  inch as from A to 3 and E to 4 by a straight line.

When marking on the material the line 3 to 4 is laid even with a fold of the goods. The slight increase in width at the back-center on the waist-line is taken off from the sideseam directly opposite, as represented by the heavy line.

The material must be well stretched at the sideseam and shrunk at the back-center on the waist-line.



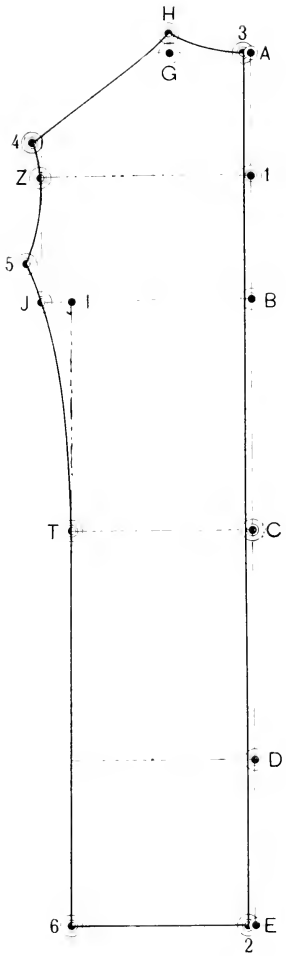

Diagram 32.

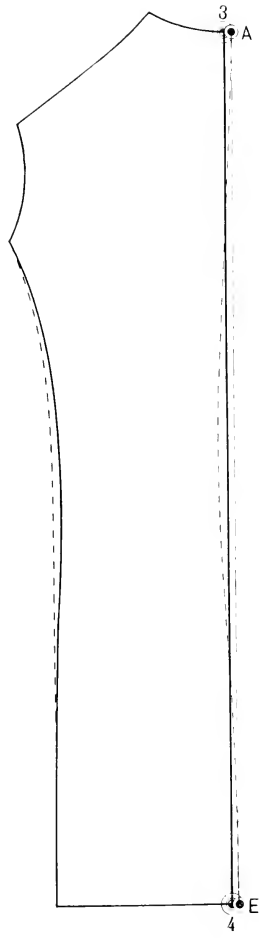

Diagram 33.

## THE SLEEVE.

### Diagrams 34 and 35.

THE measures used for the accompanying diagrams are as follows: 18 length, 16 elbow, 12 hand,  $16\frac{1}{4}$  scye. The scye,  $16\frac{1}{4}$ , is the make-up size (after deducting for six seams). It is obtained by placing the end of the tape-measure at 2 (see diagram 4) and measuring to 3, keeping  $\frac{1}{4}$  inch from the edge of the scye, as represented by the broken line. Then place the quantity thus found at 2 and measure up to point 1 following the broken line.

We will suppose when thus measured to be  $17\frac{3}{4}$  inches. From this deduct for six seams ( $1\frac{1}{2}$  inches) and the remainder,  $16\frac{1}{4}$ , is the **make-up size**.

Diagram 34—Take about a yard of paper and fold it lengthwise. Press the fold flat. Now open out the fold and lay the paper with the hollow of the crease underneath. The crease-line thus made is represented by the heavy line A B.

Place the angle of the drafting-square on the crease-line as at C and the end of the long arm 2 inches backward of the crease-line as at D. Make a mark at C; draw a line from C to D and continue the line upward towards F.

C to E is the same as from the front-scye notch to the breast-line,  $1\frac{1}{2}$  inch. Square backward from E by the line C D, and forward towards X.

E. to F is the same as J to Z on the back of the coat. Square by the line F D from F towards J.

E to L is a full fourth of the scye,  $4\frac{1}{16}$  inches. Square upward from L.

F to J is a full half of the scye,  $8\frac{1}{8}$  inches. L to K is a full third of the scye,  $5\frac{7}{8}$  inches.

Lay the pattern of the forepart on the sleeve draft, the breast-line directly over the line X Z, and the front-scye notch on the crease-line, as at C. Mark along the edge of the scye from C just past the line F J, and from C to H, as represented by the broken line.

Establish G and H each  $\frac{1}{2}$  inch from the edge of the scye, and shape from J through K and G to C, and from C through M, which is  $\frac{1}{2}$  inch above the broken line, to H as represented.

From C, following the solid line through M to H and on to I, is  $\frac{3}{4}$  inch more than the paper-size of the underarm scye (2 to Z, Diagram 4). Shape from I to H.

E to Q is the length, 18 inches. Pivot at J and sweep from Q

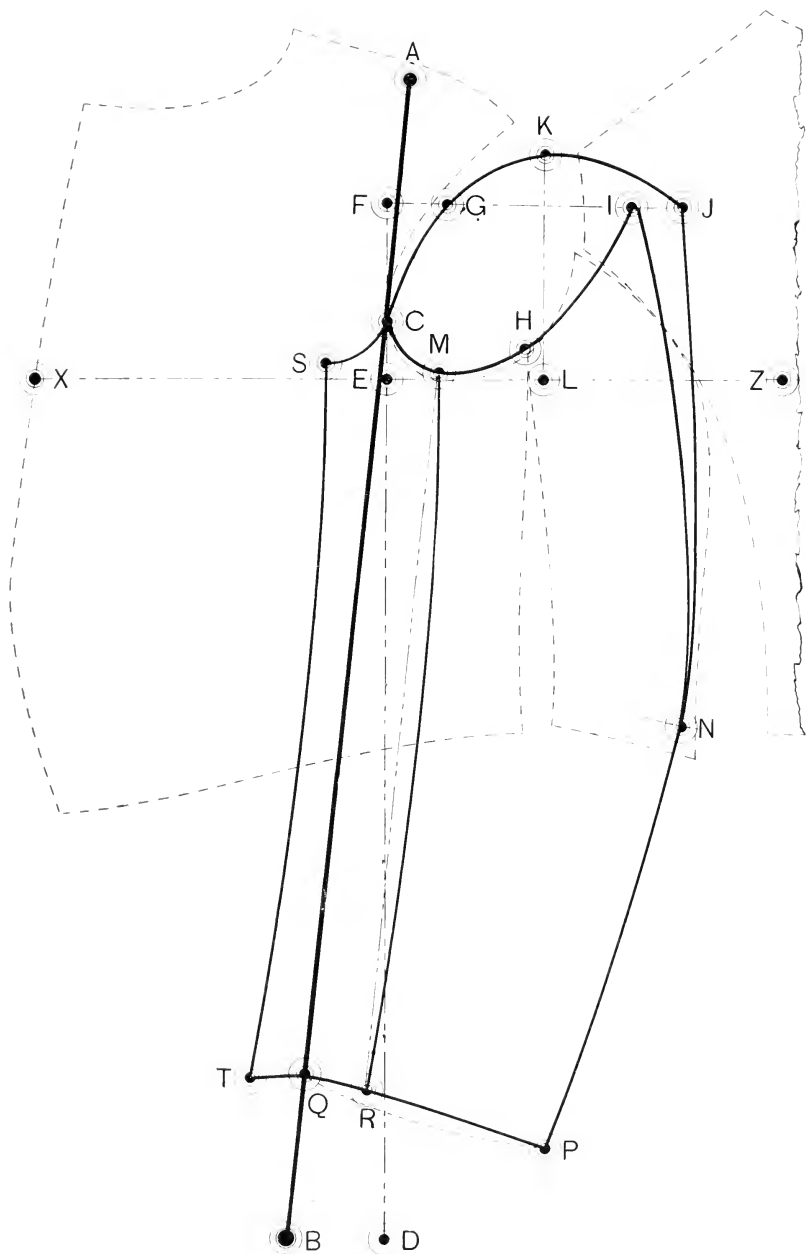

Diagram 34.

toward P. Q to P is  $\frac{1}{2}$  inch more than one-half the size at the hand,  $6\frac{1}{2}$  inches in all. From the crease-line at the elbow across to N is  $1\frac{1}{4}$  inch more than one-half the size at the elbow,  $9\frac{1}{4}$  inches in all. Shape from J through N to P, P to Q, and from  $\frac{1}{2}$  inch backward of I to N as represented.

Fold the paper on the crease-line A B and cut through both thicknesses from Q to P, N, J, K, and G to C. Open out the crease and cut singly from N to I, H and M to C. Make a notch at C.

The pattern will now appear as represented by points J, C, I, S, Q, P and N back to J on Diagram 35.

Diagram 35—The line C Q is the **first crease-line** and corresponds with the line A B on Diagram 34.

From the line C Q to the line M R is  $1\frac{1}{2}$  inch. Run a tracer along the line M R and fold the under-sleeve portion over on the top-sleeve as represented. Now cut through both thicknesses of paper from M to R, hollowing  $\frac{3}{4}$  inch from the straight line at the elbow opposite N as represented by the solid line.

When in this position the line M R represents the forearm seam of both portions. When in the position shown on Diagram 34, the forearm seam of the top-sleeve is represented by the line S T and of the under-sleeve by the line M R.

It should be observed that the line C D (Diagram 34) is at a right-angle with the breast-line X Z, and that the position of the front of the sleeve at the bottom, as at Q forward of the perpendicular line C D, is regulated by the distance at which D is placed backward of B. For an over-erect form the line C D should be drawn nearer to the crease-line A B at the bottom, and for one more stooping than the average form it should be drawn further back. This will cause the sleeve to hang further back at the bottom for an erect form and further forward for a stooping form.

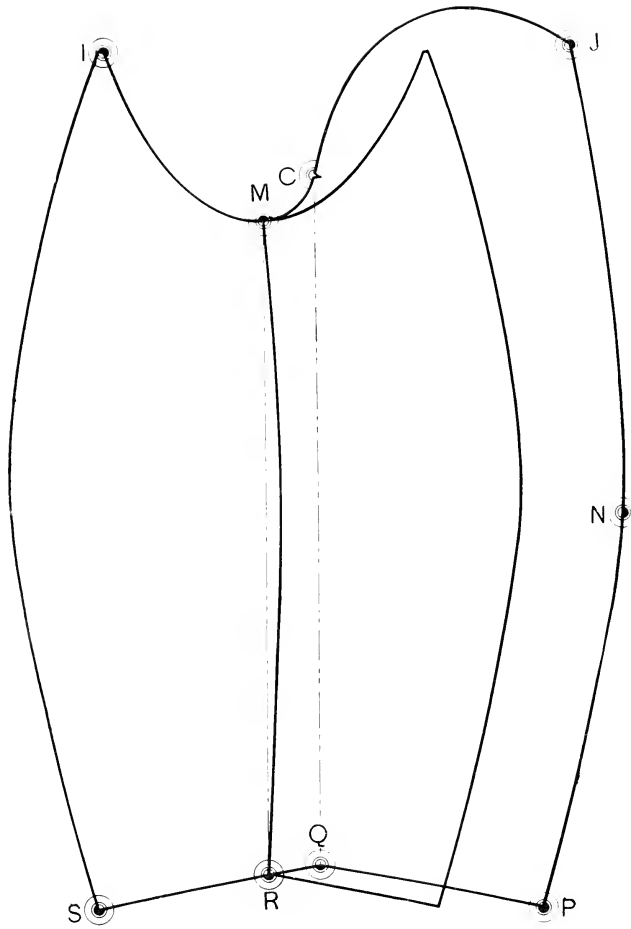

Diagram 35.

## OVERCOATS.

(Allowance for extra size.)

**T**HE measures for an overcoat **only** should be taken **over the under-coat**. Then allowances are to be made for seams and ease only, when drafting, the same as explained for under-coats.

When executing an order for an under and overcoat, the measures may be taken over the vest in the same manner as for an under-coat. Then, when drafting for the overcoat, besides the usual allowances for seams, the following allowances must also be made for **extra size**:

### For Light-Weight Material.

To the back-scye depth, front-scye depth, blade and back-waist, each  $\frac{1}{2}$  inch; to the half-back width,  $\frac{1}{4}$  inch; to the over-shoulder, 1 inch, and to the breast, waist and seat, each 2 inches.

### For Medium Heavy-Weight Material.

To the back-scye depth, front-scye depth, blade and back-waist, each  $\frac{3}{4}$  inch; to the half-back width,  $\frac{3}{8}$  inch; to the over-shoulder,  $1\frac{1}{2}$  inch, and to the breast, waist and seat, each 3 inches.

### For Extra Heavy-Weight Material.

To the back-scye depth, front-scye depth, blade and back-waist, each 1 inch; to the half-back width,  $\frac{1}{2}$  inch; to the over-shoulder, 2 inches, and to the breast, waist and seat each 4 inches.

## THE "CHESTERFIELD" OR FLY-FRONT OVERCOAT.

### Diagram 36.

**T**HE measures used for the accompanying diagram are: 38 breast 34 waist, 39 seat,  $7\frac{1}{4}$  half-back width,  $9\frac{1}{2}$  back-scye depth,  $17\frac{1}{2}$  natural waist, 26 seat-line, 40 length,  $11\frac{1}{2}$  blade, 13 front-scye depth,  $17\frac{1}{4}$  over-shoulder,  $8\frac{3}{4}$  back-waist. These measures are as taken over the under-coat.

### To Draft.

Square the lines A G and A E.

Place the end of the tape-measure  $\frac{1}{4}$  inch below A and mark the back-scye depth at B, the natural waist at C, seat-line at D and  $\frac{1}{4}$  inch more than the full length at E.

B to **1** is  $\frac{1}{2}$  of the back-scye depth. Square forward from each of the above points.

C to F is  $\frac{1}{2}$  inch. E to **11** is  $\frac{1}{2}$  inch. Shape the center-of-back from A through F to **11** as represented.

A to G is  $\frac{1}{6}$  breast. G to H is  $\frac{1}{24}$  breast. From **1** to Z is  $\frac{1}{2}$  inch more than the half-back width. Square upward and downward from Z.

From the center-of-back opposite B to K is the blade. K to L is  $\frac{3}{4}$  inch. K to M is  $1\frac{1}{2}$  inch.

K to P is  $1\frac{1}{4}$  inch more than  $\frac{1}{6}$  breast. From the center-of-back opposite B to Q is a full half of the breast. Q to R is  $2\frac{1}{2}$  inches. R to **2** is 2 inches **or to style**.

Square upward from P and M, and downward from K to establish S.

I is half-way from the center-of-back opposite B, to M. I to J is  $1\frac{1}{4}$  inch. (By squaring upward from J the natural half-back width is obtained.) Connect H and P.

From **4** to **12** is  $\frac{1}{2}$  inch, more or less, **according to style**. Shape from **12** to the front-scye notch, which is  $1\frac{1}{2}$  inch above M. The bottom of the scye is  $\frac{1}{4}$  inch below the breast-line. Connect **1** to M to establish **5** (or establish **5** according to style).

F to T is  $\frac{1}{2}$  inch more than  $\frac{1}{3}$  breast, or as wide as the current style. From **11** to **6** is 1 inch more than F to T. Shape the side-back from **5** through T to **6** as represented.

L to X is  $\frac{3}{4}$  inch more than the front-scye depth. L to Y is  $\frac{3}{4}$  inch more than the over-shoulder. Connect L and X to establish **14**.

Pivot at L and sweep forward from X. Pivot at **14** and sweep backward from Y.

X to **17** is  $\frac{1}{4}$  breast. Square forward from **17**.

Extend the center-of-front line upward by a sweep from R to X, finding a pivot just below B, as at the unlettered circled disk.

F to T and S to U is the back-waist. F to T and U to V is a full half of the waist. V to W is  $2\frac{1}{4}$  inches. W to **3** is the same as R to **2**. Square downward from **3** to establish X.

The quantity between T and U (3 inches for this draft) represents a surplus through the back-waist more than the back-waist measure. As the overcoat is not made close-fitting through the back-waist, the amount taken out between T and **9** and in the fish under the arm depends upon style. In this instance T to **9** is 1 inch and the fish is  $\frac{1}{2}$  inch wide on the waist-line. This amount, taken out between T and **9** and in the fish, gives a moderately close-fitting back-waist.

Square downward from U to establish **7**.

When the seat is 5 inches larger than the waist, as in this case, then from 7 to 8 is  $3\frac{1}{2}$  inches. For each additional inch that the seat is more than 5 inches larger than the waist, then from 7 to 8 is  $\frac{1}{4}$  inch more than  $3\frac{1}{2}$  inches. When the seat is less than 5 inches larger than the waist, then from 7 to 8 is  $\frac{1}{4}$  inch less than  $3\frac{1}{2}$  inches for each inch of difference less than 5.

Draw a guide-line from 5 through 8 and shape the sideseam as represented.

N to 18 is  $\frac{1}{2}$  inch, or to style. Shape the bottom as represented, making 9 to 10 the same as T to 6.

Cut out the backpart and lay it in the position shown on the upper part of the diagram. Point A is on the sweep-line forward of X, H is on the line which is squared upward from F and B is on the sweep-line from Y. This establishes 13. Place a weight on the backpart and mark lightly along the back-shoulder seam. Connect B and 14 to establish 15.

Shape the front-shoulder from 13 through 15, rounding off about  $\frac{3}{4}$  inch below the outer back-shoulder point to 16, as explained for Diagram 4. Make 13 to 16 the same as H to 12, and finish the scye from 16 to the front-scye notch.

Shape the gorge lightly from 13, about as represented. It touches the line which is squared forward from 17, but is liable to be changed when the style points are obtained later.

Now establish the end of the roll and draw the rever-crease-line towards a point  $\frac{3}{4}$  inch forward of 13.

The broken line numbered 27 is at the height of the neck in front. It is drawn parallel with the breast-line from where the line which is squared forward from 17 intersects with the sweep-line from R to X. The line numbered 28 is midway between the neck and breast lines.

Now study carefully the style which you are to reproduce in the overcoat, and mark the position of point 19, which appears to be on the fashion-plate selected about half way between the neck and breast lines and half way between the rever-crease-line and the front-of-scye. Connect 19 and the end of the roll, and mark, approximately, at least, the direction of the run of the top of the rever, as from 19 towards 20. Establish 20 according to style in its relation to points 19 and 23.

Square across by the crease-line from 19 and 20. From the crease-line to 21 is the same as to 19, and from the crease-line to 22 is the same as to 20. Now reshape the gorge from 13 to 22.

From about an inch backward of 22 draw a line about midway between Q and R, as from 24 to 26. Make a tracing of the part of the rever which is above the breast-line and forward of the



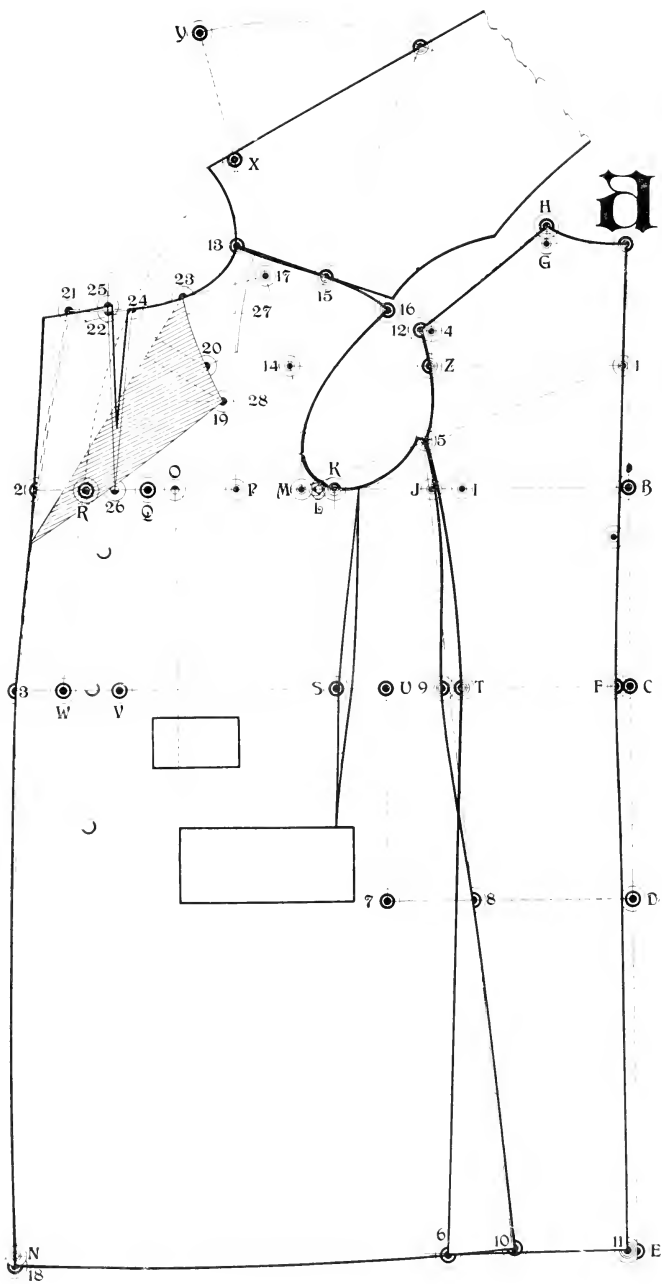

Diagram 36.

line from 24 to 26 and, pivoting it at 26, swing the upper part forward 1 inch and mark around it. This gives 25 and the top of the rever. Shape from the point of the rever to the end of the roll, also the dart from 25 to 26. When cutting out the dart add  $\frac{1}{4}$  inch forward of the line from 24 to 26 and the same backward of the line from 25 to 26 as represented.

The line X R W is the center-of-front. From this line to the button-line is  $\frac{3}{4}$  inch less than to the front edge.

M to O is  $\frac{1}{4}$  breast. Square downward from O for the front of the pocket. The flap is cut to finish about 3 inches wide and the opening is about  $\frac{1}{3}$  breast.

When it is desired that the coat shall be less shaped in at the back-waist than as on this diagram, then omit the fish under the arm; reduce the width of the forepart  $\frac{1}{2}$  inch opposite 5 and J and reshape the scye, as explained for Diagram 27.

## SINGLE-BREASTED OVERSACK.

### Diagram 37.

**T**HIS modern Fly-Front Oversack, suitable for Spring wear, has very pleasing lines, and, when contrasted with styles heretofore worn, presents many points of decided change and improvement. It is 40 inches in length for a man 5 feet 8 inches. The shoulder seams are somewhat higher than formerly, and are of natural width. The shoulders are made plain, with but very little padding. The gorge is low. The fronts close with two buttons, the top one being about an inch above the waist-line, and the revers are moderately peaked. It is two-thirds tight-fitting at the back-waist and the skirts have a decided flare. The center-back seam has a deep vent extending to within 3 inches of the waist-line. The explanation for this diagram will show the adaptability of the system to the fluctuations of fashion. The same principle that underlies the construction of all the coats described in this work are employed without deviation. Changes in style from season to season affect the position of seams, shapeliness or fullness at the waist and through the skirts, the length of roll, depth of gorge, shape of the revers and front, and length of coat, etc. The cutter must always keep in touch with current styles, and must conform to all that pertains to the style features of a garment. This the intelligent cutter can do and not depart an iota from any fixed principle.

The accompanying diagram is a reduction of a draft made from the following measures, viz.:

40 breast, 36 waist, 41 seat,  $7\frac{5}{8}$  half-back width, 9 back-scye

depth,  $17\frac{1}{2}$  natural-waist,  $26\frac{1}{4}$  seat line, 40 length, 12 blade,  $13\frac{1}{4}$  front-scye depth,  $18\frac{1}{4}$  over-shoulder,  $8\frac{3}{4}$  back-waist,  $17\frac{1}{4}$  scye.

### To Draft.

Place the angle of the square at A and square forward and downward.

From  $\frac{1}{4}$  inch below A to B is the back-scye depth, to C is the natural waist, to D is the seat-line and to E is the length. Point 1 is half of the back-depth above B. Square forward from 1, B, C, D and E.

A to G is  $\frac{1}{6}$  breast. G to H is  $\frac{1}{24}$  breast. C to F is  $\frac{3}{4}$  inch. Connect A, F and E. This establishes 1 and B.

B to K is the blade. Square down from K to establish S. K to L is  $\frac{3}{4}$  inch. K to M is  $1\frac{1}{2}$  inch. I is half-way between B and M. I to J is  $1\frac{1}{4}$  inch. Square up from M and J. This gives O, Z and 19.

K to P is  $1\frac{1}{4}$  inch more than  $\frac{1}{6}$  breast. Square up from P. B to Q is a full half of the breast. Q to R is  $2\frac{1}{2}$  inches. R to 2 is  $2\frac{1}{4}$  inches or to style.

Connect H and 30 which is half-way between Q and R. Shape the scye from 4 (which is  $\frac{1}{2}$  inch forward of the line from 19 to J), to the notch at front of scye, which is  $1\frac{1}{2}$  inch above M, dropping  $\frac{1}{2}$  inch below the breast-line as represented.

Connect 1 and K. This gives 5. 20 is half-way between Z and O. Draw a straight line from 20 through S. This gives X.

F to T is  $\frac{1}{3}$  breast. 9 from E is  $2\frac{1}{2}$  inches more than F to T. Shape the side back seam from 5 to T and 9 as represented. Below 5 it is rounded slightly forward of a straight line from 5 to T, crossing the straight line half-way from 5 to T and from there it is hollowed slightly from the straight line to T.

F to T and S to U is the back-waist. F to T and U to V is a full half of the waist. V to W is  $2\frac{1}{4}$  inches. W to 3 is the same as R to 2. Connect R and W. Connect 2 and 3.

The draft between F and S measures  $11\frac{1}{2}$  inches. The back-waist measure being  $8\frac{3}{4}$  inches, there is a surplus of material between F and S of  $2\frac{3}{4}$  inches. This surplus is represented by the quantity between T and U. As the coat is to be  $\frac{2}{3}$  tight-fitting through the back waist,  $\frac{2}{3}$  of the surplus is to be taken out between T and 6 and S and 7 as follows:  $\frac{2}{3}$  of  $2\frac{3}{4}$  inches is about 2 inches.  $\frac{3}{4}$  of this, or  $1\frac{1}{2}$  inch is taken out between T and 6 and the remaining  $\frac{1}{2}$  inch between S and 7.

Square down from U to establish 8. Square backward from 8. 10 from 8 is  $3\frac{1}{2}$  inches. Draw straight lines from 5 to 6

and 11. Square forward from E to establish 9. 11 from 5 is the same as 9 from 5.

Square downward from 3 to establish 12, and shape the bottom from 11 to 29 passing 1 inch below 12. From  $2\frac{1}{2}$  inches below F add  $1\frac{1}{4}$  inch for the vent as represented.

L to X is  $\frac{3}{4}$  inch more than the front-depth, and on to Y is  $\frac{3}{4}$  inch more than the over-shoulder. Draw a straight line from L through X. This gives 14. Pivot at L and sweep forward from X. Pivot at 14 and sweep backward from Y.

17 from X is  $\frac{1}{4}$  breast. Square forward from 17. Cut out the back part leaving a margin of paper above A to H, and lay it in the position shown by the part which is shaded. H is on the line squared up from P, A is on the sweep-line forward of X and B touches the sweep-line backward from Y. Connect B and 14. This establishes 15 and 13.

Shape the front-shoulder from 13 through 15 rounding off  $\frac{3}{4}$  inch below the outer back-shoulder point towards 16 and make 13 to 16 the same as H to 4. Finish the scye from 16 to the notch at front-of-scye.

Establish the end of the roll, point 28 according to style. In this case it is  $1\frac{1}{2}$  inch above the waist-line.

Draw a slightly outward curved line from 28 to a point  $\frac{3}{4}$  inch forward of 13. Establish 21 and 22 according to style. Square forward by the crease-line from 21 and 22. From the crease-line to 23 is the same as to 22 and from the crease-line to 24 is the same as to 21.

Shape the gorge from 13 to 23, and the rever from 23 to 24 and 28.

Draw a straight line from 30 to 26 as represented. Making a tracing of the rever forward of 26 and 30, lay it on the draft and, pivoting it at 30, swing the upper part forward 1 inch as from 26 to 27. Mark all around the traced piece reshaping below the point of the rever to the end of the roll.

18 from S is  $\frac{1}{2}$  inch more than  $\frac{1}{4}$  breast. Square downward from 18 and from this line square back about  $1\frac{1}{2}$  inch more than half-way from the waist-line to the seat-line. Mark for the pocket opening dropping the front end  $\frac{1}{2}$  inch below the squared line as represented.

The extra length on the seam from X through 7 is pressed in at the shading below X.

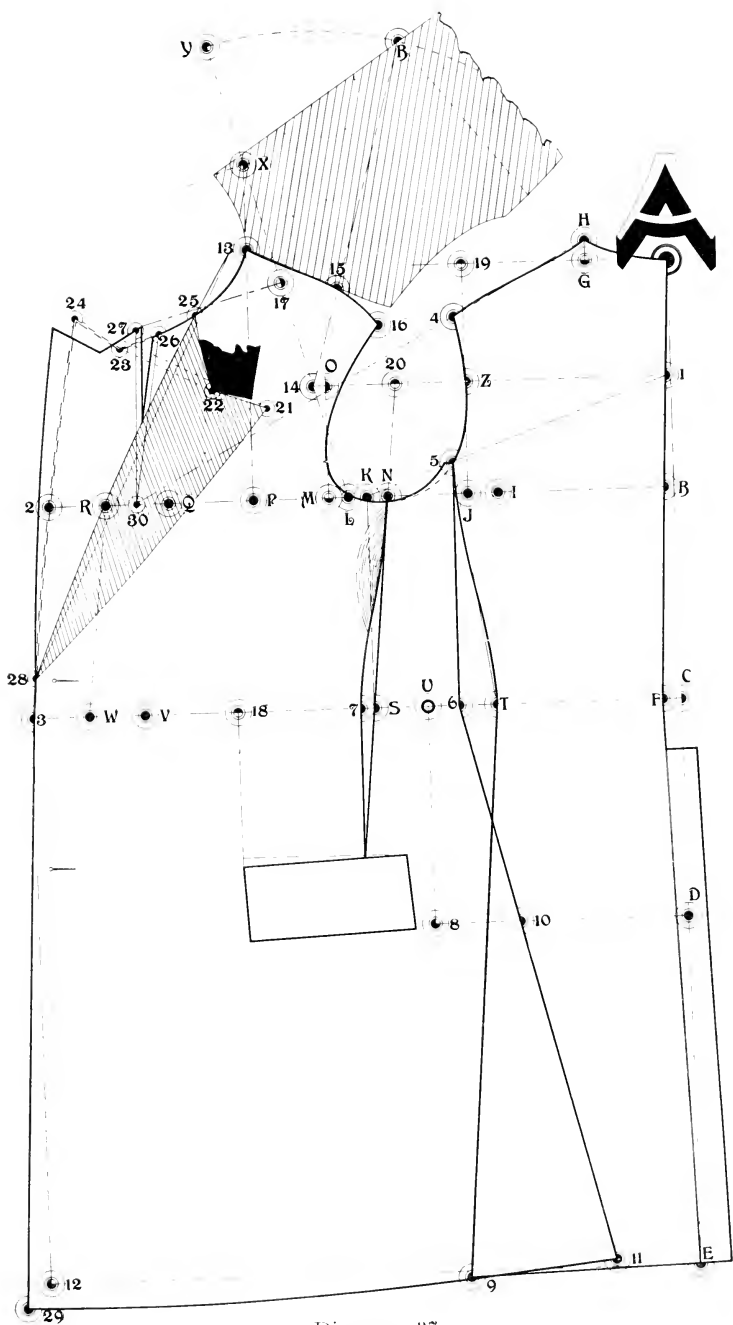

Diagram 37.

## FLY-FRONT OVERCOAT, FULL BOX BACK.

(Corpulent Form.)

### Diagram 38.

**T**HE measures used for the accompanying diagram are as follows: 40 breast, 40 waist, 42 seat,  $7\frac{5}{8}$  half-back width, 9 back-scye depth,  $16\frac{1}{2}$  natural waist, 25 seat-line, 42 length, 12 blade,  $13\frac{1}{2}$  front-scye depth, 18 over-shoulder, 9 back-waist,  $17\frac{1}{4}$  scye. These are arranged in the first row of figures below.

In the second row of figures are the allowances to be made for **extra size** when drafting an overcoat from the body measures taken as for an under-coat, **over the vest**, and when the material is **light weight**.

The measures then, as used when drafting, are arranged in the third row of figures:

40: 40: 42:  $7\frac{5}{8}$ : 9 :  $16\frac{1}{2}$ : 25 : 42: 12 :  $13\frac{1}{2}$ : 18: 9 :  $17\frac{1}{4}$ .  
 2: 2: 2:  $\frac{1}{4}$ :  $\frac{1}{2}$ :  $\frac{1}{2}$ :  $\frac{1}{2}$ : :  $\frac{1}{2}$ :  $\frac{1}{2}$ : 1:  $\frac{1}{2}$ : 2 .  
 42: 42: 44:  $7\frac{7}{8}$ :  $9\frac{1}{2}$ : 17 :  $25\frac{1}{2}$ : 42:  $12\frac{1}{2}$ : 14 : 19:  $9\frac{1}{2}$ :  $19\frac{1}{4}$ .

### To Draft.

Obtain points A, B, C, D, E and F in the same manner as explained for Diagram 36 and square forward from each.

All the points on and above the breast-line, excepting 5, 31, 32 and 33, are obtained in the same manner as for Diagram 36.

Observe that points 1 B and F **are on the line A. F.**

B to 5 is 1 inch less than  $\frac{1}{2}$  breast. Square downward from 5 towards 6.

F to T and S to U is the back-waist. Square downward from U to establish 7.

F to T and U to V is a full half of the waist. V to W is  $2\frac{1}{4}$  inches. W to 3 is the same as R to 2. Square downward from 3 to establish X.

Take the width from B to R and, finding a pivot just below B, sweep from R to X. Now take a slightly curved rule and, holding one end at W, swing the other until it touches the sweep-line from R to X. Mark by it as represented. This establishes 31.

From 31 to 32 is the same as R to 2. Connect 32 and 3, and shape below 3 as represented **or to style**.

Shape the center-of-back from A by a straight line passing  $\frac{1}{2}$  inch backward of D, and square forward by this line from E to establish 6.

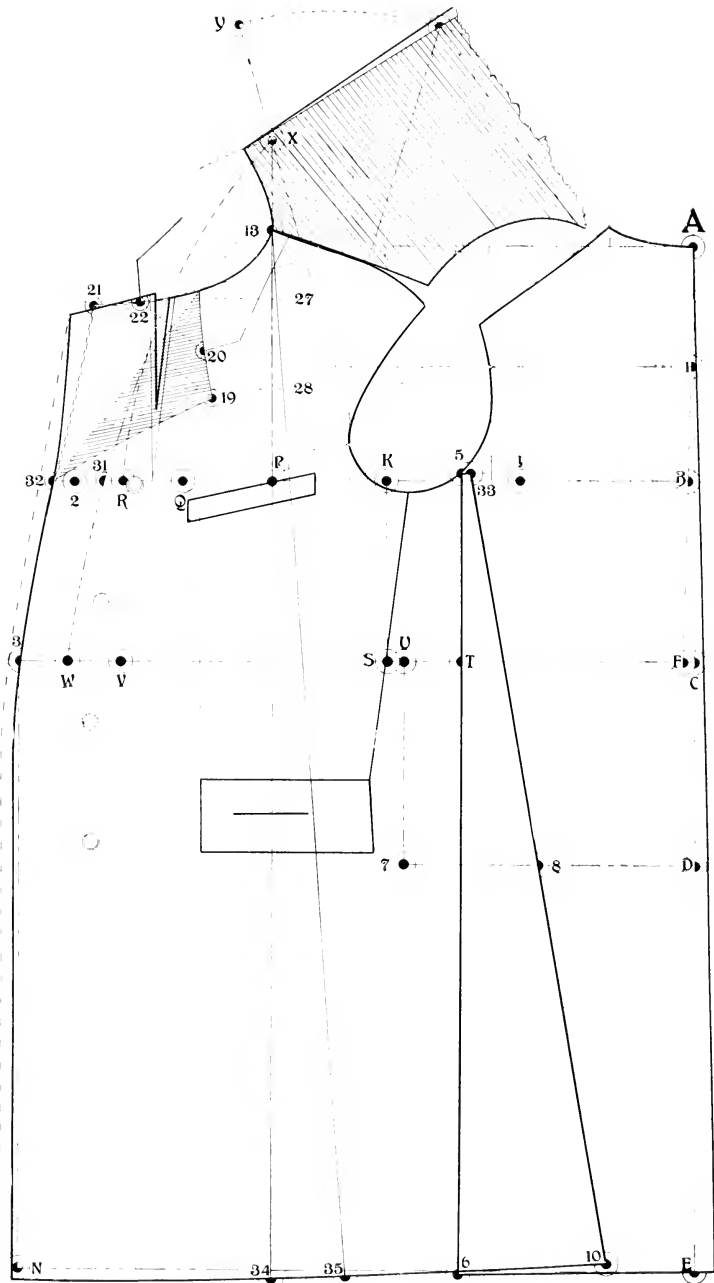

From 5 to 33 is  $\frac{1}{2}$  inch. (It may be made 1 inch if a very full blade is desired.)

From 7 to 8 is  $5\frac{1}{4}$  inches in this case. Draw a straight line from 33 through 8 and make from 33 to 10 the same as from 5 to 6. Shape the bottom from 10 to  $\frac{1}{2}$  inch below N as represented.

Establish the end of the roll, also points 19, 20, 21 and 22, and work in the neck-dart, all in the same manner as explained for Diagram 36.

Place paper underneath the draft and trace off the backpart. The forepart can then be cut whole, the sideseam on the line from 33 to 10. Cut from the scye to and across the pocket opening and spread the cut as explained for Diagram 31.

Special attention is directed to the following: To obtain the run of the front-shoulder seam make a tracing of that part only of the backpart that is above the breast-line and forward of the line A. B. Lay this piece in the position shown on the upper part of the diagram.

From 7 to 8 is 6 inches, only when the seat is 5 or more inches larger than the waist. For each inch that the difference is **less than 5 inches**, then from 7 to 8 is  $\frac{1}{4}$  inch less than 6 inches,  $5\frac{1}{4}$  inches for this draft.

The fullness through the forepart can be exaggerated by squaring downward from P and proceeding as follows: Take another piece of paper; lay the forepart pattern on it; mark from 13 across the shoulder, along the scye to 33, down to 10 and across the bottom to 34. Pivot at 13; swing the bottom forward 3 inches, as from 34 to 35, and mark to N and upward to 13. Also add  $\frac{1}{2}$  inch to the front below the waist line to nothing at the point of the rever as represented by the broken line.



## THE INVERNESS.

(Without Sleeves.)

### Diagram 39.

**T**HE measures used for the accompanying diagram as taken over the under coat are as follows: 38 breast, 34 waist, 39 seat,  $9\frac{1}{2}$  back-scye depth,  $17\frac{1}{4}$  natural waist, 26 seat-line, 45 length,  $11\frac{1}{2}$  blade, 13 front-scye depth,  $18\frac{1}{4}$  over-shoulder and  $8\frac{1}{4}$  back-waist.

**When drafting, increase the breast, waist and seat each 1 inch.** The measures will then be as follows, viz.:

39: 35: 40:  $9\frac{1}{4}$ :  $17\frac{1}{4}$ : 26: 45:  $11\frac{1}{2}$ : 13:  $18\frac{1}{4}$ :  $8\frac{1}{4}$ .

### To Draft.

Square the lines A E and A 19.

Place the end of the tape-measure  $\frac{1}{4}$  inch below A and mark the back-scye depth at B, the natural waist at C, seat-line at D and  $\frac{1}{4}$  inch more than the length at E.

B to 1 is half of the back-scye depth. Square forward from 1, B, C, D and E.

C to F is  $\frac{1}{2}$  inch. Connect A and F to establish N. C to 4 is  $\frac{1}{2}$  inch. Draw a straight line from A through 4 and square forward from 5.

A to G is  $\frac{1}{6}$  breast. G to H is  $\frac{1}{24}$  breast. N to I is half of the blade. I to J is 2 inches.

E to 6 is 2 inches more than  $\frac{1}{3}$  breast. Shape the backpart from A to H, J and 6 as represented.

N to K is the blade. Square downward from K to establish S.

S to U is the back-waist less the width of the backpart from F to the sideseam. Square downward from U to establish 8.

From 8 to M is 6 inches.

Draw a straight line from J through M. J to R is  $\frac{1}{3}$  breast.

K to P is  $\frac{1}{4}$  inches more than  $\frac{1}{6}$  breast. Square upward from P.

N to Q is a full half of the breast. Q to R is  $2\frac{1}{2}$  inches. R to 2 is 2 inches, **or to style.**

S to V is a full half of the waist less the back-waist,  $9\frac{1}{4}$  inches for this draft. V to W is  $2\frac{1}{4}$  inches. W to 3 is the same as R to 2. Square downward from 3 and W. Shape the bottom from 7, passing  $\frac{1}{2}$  inch below Z and the front from 2 through 3 to 21 as represented.

K to L is  $3\frac{1}{4}$  inch. L to X is  $3\frac{1}{4}$  inch more than the front-scye depth, and on to Y is  $3\frac{1}{4}$  inch more than the over-shoulder. Pivot at L and sweep forward from X. Pivot at 14 and sweep backward from Y.

X to 17 is  $\frac{1}{4}$  breast. Square forward from 17. Square upward from J to establish 19. Connect 19 and N to establish 10.

Cut out the backpart and place it in the position shown on the upper part of the diagram with H resting on the line P X, A touching the sweep-line from X and N on the sweep-line from Y. This establishes 13. (When placing the backpart in position observe that point N is on the line A F, and not on the one from A through 4.) Shape the front-shoulder from 13 through 10.

From 13 to 12 is the same as H to 10. Shape the scye from 12 through L to R as represented.

Shape the gorge and rever **to taste or style.**

L to O is 1 inch more than  $\frac{1}{4}$  breast.

**The Cape.**—Apply the length straight down from X.

Lay the backpart in the same position as when drafted. Pivot at 13 and sweep backward from the length. Shape the shoulder seam from 13 through 10 and B as represented.

The front of the cape leaves the gorge to clear the reverse-line and follows the button line to the bottom.

The cape from 13 to within 3 or 4 inches of the bottom seams in with the side-back seam below H.

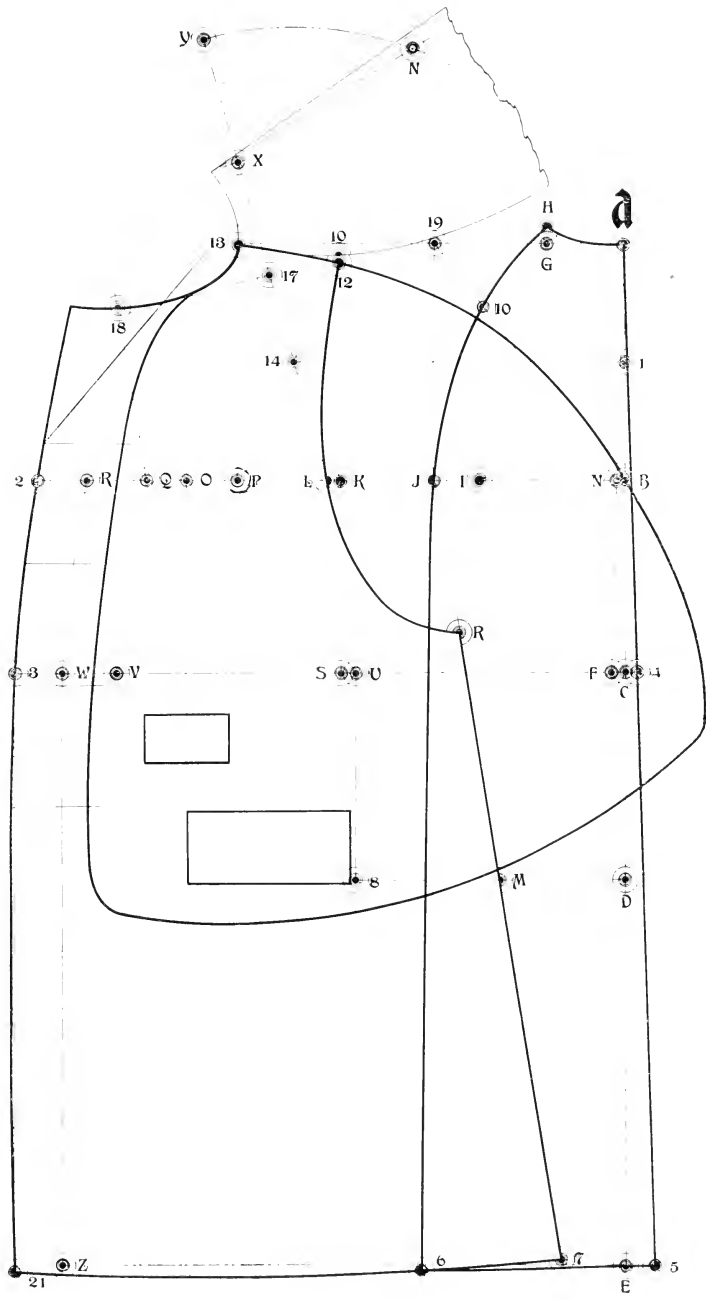

Diagram 39.  
(91)

## THE INVERNESS.

(With Sleeves.)

### Diagram 40.

**T**HE measures used and taken over the under coat are the same as for the preceding diagram, except that the waist is 37 and back-waist  $8\frac{3}{4}$  inches. When drafting, increase the breast, waist and seat each 1 inch. The formula will then be as follows:  
39: 37: 40:  $9\frac{1}{2}$ :  $17\frac{1}{4}$ : 26: 45:  $11\frac{1}{2}$ : 13:  $18\frac{1}{4}$ :  $8\frac{3}{4}$ .

### To Draft.

Square forward and downward from A, and obtain the lengths to B, C, D and E, also point 1, and square forward from 1, B, C, D and E.

C to 10 is  $\frac{1}{2}$  inch. Draw a straight line from A through 10 for the center-of-back.

C to F is  $\frac{1}{2}$  inch. Connect F and A to establish N.

N to K is the blade. K to L is  $\frac{3}{4}$  inch. K to M is  $1\frac{1}{2}$  inch. K to P is  $1\frac{1}{4}$  inch more than  $\frac{1}{6}$  breast. N to Q is a full half of the breast. Q to R is  $2\frac{1}{2}$  inches. R to 2 is 2 inches or to style. Square upward from M and P and downward from K. This gives S.

From the line from J 19 to 4 is  $\frac{3}{4}$  inch. From 9 to Z is  $\frac{1}{4}$  inch. Shape the scye from 4 through Z to the front-scye notch  $1\frac{1}{2}$  inch above M, dropping  $\frac{1}{2}$  inch below the breast-line as represented.

From 4 to 5 is 1 inch. E to 6 is 2 inches more than  $\frac{1}{3}$  breast. Connect J and 6 to establish T, and shape from 5 through T to 6 as represented.

All the points on the forepart above the breast-line are obtained in the same manner as explained for Diagram 39. Observe particularly that point N is on the line A F, not on the center-of-back line, and that N rests on the sweep-line from Y.

F to T and S to U is the back-waist. F to T and U to V is a full half of the waist. V to W is  $2\frac{1}{4}$  inches. W to 3 is the same as R to 2. Square downward from W and 3. Make from 5 to 12 the same as from 5 to 6 and shape from 12 to 21 passing  $\frac{1}{2}$  inch below 20.

Take the distance from N to R and finding a pivot just below N sweep from R to X. This gives 18. The line below 18 through R and W is the center-of-front.

The cape is drafted in the same manner as explained for Diagram 39. It is represented by the broken lines.

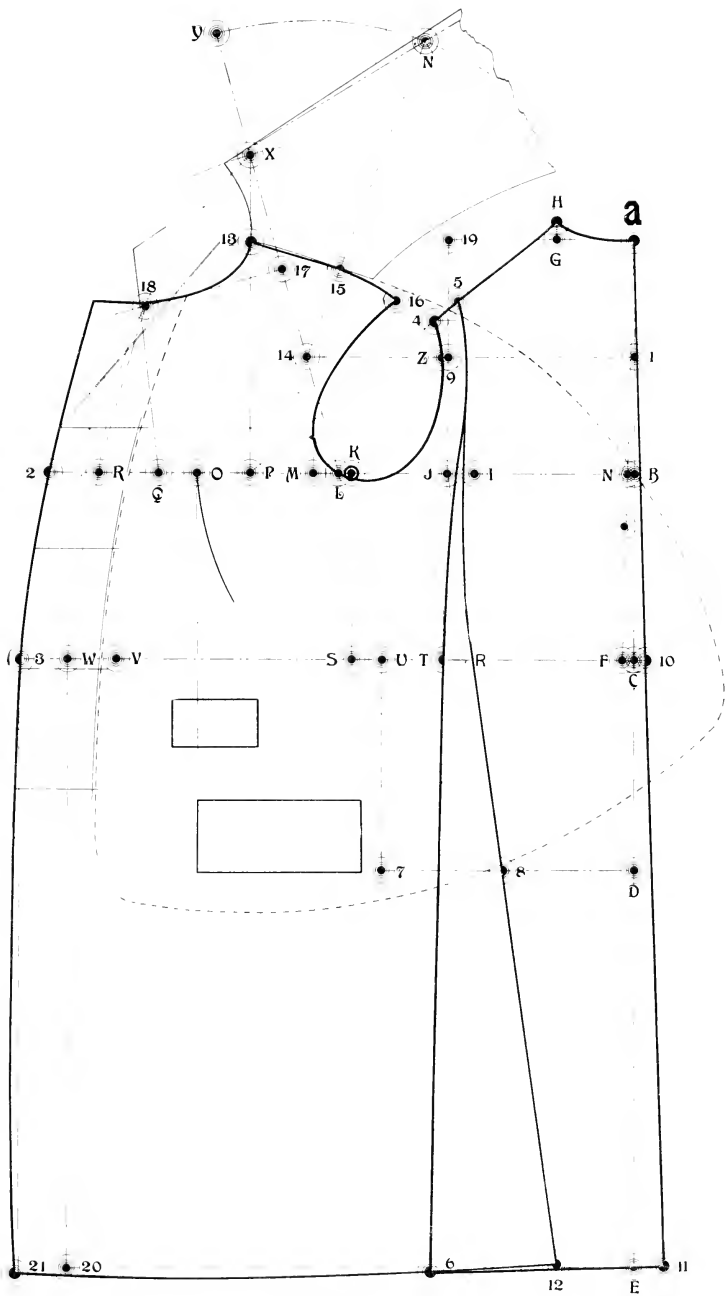

Diagram 40.

## DOUBLE-BREADED FULL BOX OVERCOAT.

(Square and Raglan Shoulders, Shawl Collar.)

(Satin or Fur Lined.)

### Diagram 41.

**T**HE measures used for the accompanying diagram, as taken over the under coat, are as follows: 38 breast, 34 waist, 39 seat,  $8\frac{3}{4}$  back-scye depth, 17 natural-waist,  $25\frac{1}{2}$  seat-line, 46 length,  $7\frac{3}{8}$  half-back width,  $11\frac{1}{2}$  blade,  $12\frac{3}{4}$  front-scye depth,  $17\frac{1}{2}$  over-shoulder,  $8\frac{1}{4}$  back-waist.

For satin lining draft from these measures as hereinafter explained: For a fur-lined overcoat draft in all respects in the same manner, **but to the increased lengths and widths**, as follows, viz.: 40; 36; 41;  $9\frac{1}{4}$ ;  $17\frac{1}{2}$ ; 26; 46;  $7\frac{5}{8}$ ; 12;  $13\frac{1}{4}$ ;  $18\frac{1}{2}$ ;  $8\frac{3}{4}$ .

The fur-lined coat closes with loops and buttons. The buttons are placed as much backward of the center-of-front line as the front edge is forward of it. For the satin-lined coat they are placed 1 inch forward of their position on the diagram, provided the fronts close with buttonholes.

### To Draft.

Square the lines A 19 to A E.

Place the end of the tape-measure  $\frac{1}{4}$  inch below A and mark the back-scye depth at B, the natural-waist at C, the seat-line at D and  $\frac{1}{4}$  inch more than the full length at E. Point 1 is half way between A and B. Square forward from 1, B, C, D and E.

Obtain all the points on and above the breast-line in the same manner as explained for any of the preceding diagrams, excepting points 20, 21, 22, 23, 24, 2, N and O, which are obtained as follows: Connect H and Q instead of H and P.

R to 2 is 4 inches or to style. By squaring upward from M establishes 20.

The points on the waist-line must be established before proceeding further.

S to U is the back-waist. U to V is a full half of the waist. V to W is 2 inches. W to 3 the same as R to 2. Square downward from 3 and connect 2 and 3.

Now establish the end of the roll and draw the crease-line by an outward curve from a straight line from the end of the roll to a point  $\frac{1}{2}$  inch forward of the front-shoulder point.

Shape the collar on the forepart and backpart as represented by the parts which are shaded, according to style. For a shawl

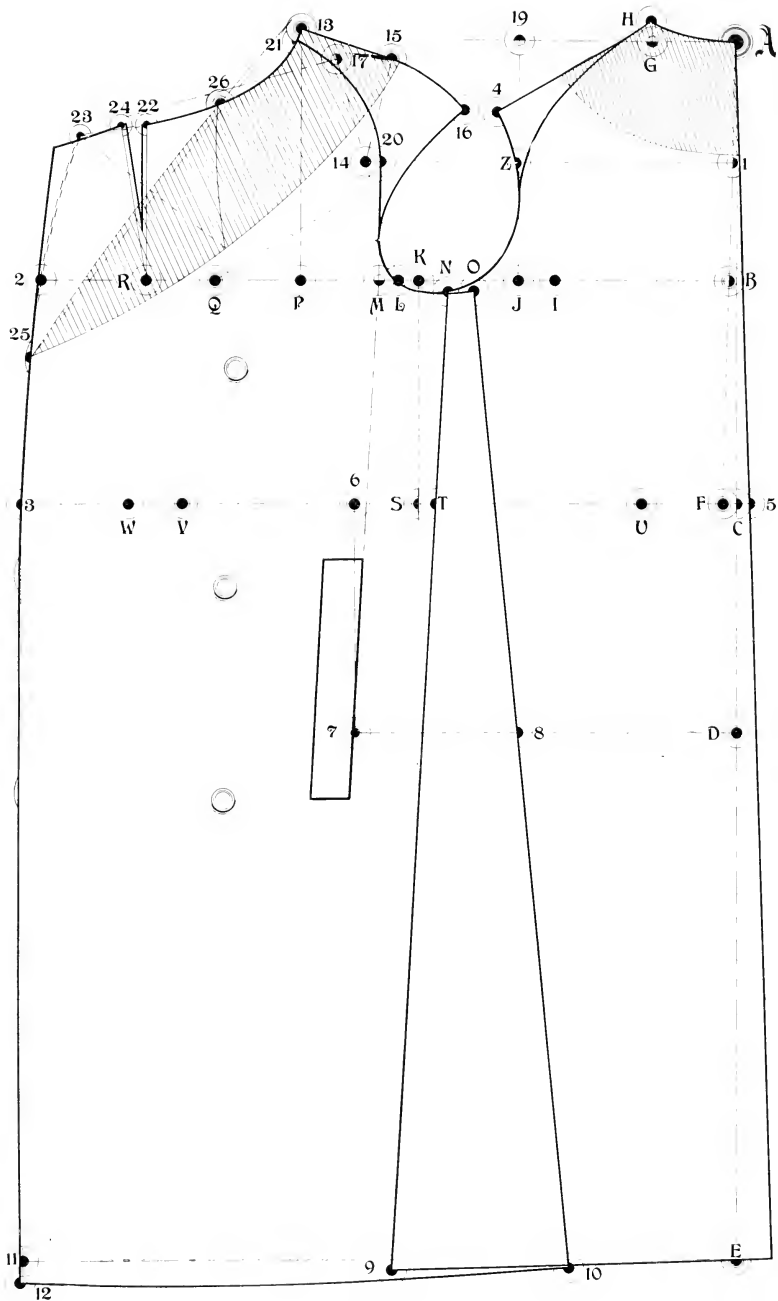

Diagram 41.

collar it is immaterial whether the gorge is shaped high or low. Shape it about as represented.

Square upward from R to establish **22**. Establish **23** as much forward of the crease-line as the width of the rever backward of it, and shape the front from **23** past the end of the roll and through **3** to the bottom as represented.

Make a tracing of that part of the rever forward of R and **22** and, pivoting it at R, swing the upper part forward 1 inch, as from **22** to **24**. Mark by the traced piece from **24** to the point of the rever and to the end of the roll as represented by the heavy lines. Add a seam below **22** and **24**.

N is half way between J and M. E to **9** is 2 inches more than B to N. Connect N and **9**.

The forepart overlaps the backpart 1 inch, as from N to O.

The backpart from F to T is, in this case,  $2\frac{1}{4}$  inches wider than the back-waist. Point **6** is therefore established  $2\frac{1}{4}$  inches forward of S. (C to F is  $\frac{1}{2}$  inch, as before.) Square downward from **6** to establish **7**. From **7** to **8** is 6 inches, or more if more fullness is desired through the seat. Draw a straight line from O through **8** and make O to **10** the same as N to **9**.

From **11** to **12** is  $\frac{3}{4}$  inch. Shape from **10** to **12** as represented.

The pocket is on a line drawn from M parallel with line N to **9**. It is 2 inches below the waist-line and is 9 inches long. It is finished with a welt  $1\frac{1}{2}$  inch wide.

C to **5** is  $\frac{1}{2}$  inch. It may be made 1 inch if more fullness is desired. Shape the center-of-back from A through **5**. Point **9** is established by squaring forward from the center-of-back.

**For the Raglan shoulder** shape the back-shoulder as represented, and for the front-shoulder establish **21**,  $\frac{1}{2}$  inch or more if desired below **13** and shape from **21** through **20** as represented.

Mark the shape of the outer edge of the collar by a tracer, so that it can be seen on the other side of the draft, and, after having cut the patterns for the forepart and backpart, proceed as follows:

**The Collar**—Two collars are shown on this diagram, viz.: a flat collar without stand and a creased collar with a stand. The one with a stand is drafted in the following manner:

The light lines represent the forepart and backpart of the coat shown on Diagram **41** laid together at the shoulder-seam. Points A, **13**, **23**, **25** and **26** are the same as on the preceding diagram.

Extend the crease-line from **26** past **13**. (The pattern for the coat has been cut out and the shape of the collar marked by a tracer as from **25** to **28** and **29**.)

At about the width of the backpart from **13** go downward



from the crease-line 1 inch, as from 2 to 3, and shape the seam-edge as from 3 to 26.

From 2 towards 4 is the same as 2 to 3. From the crease-line toward 5 is the same as from the crease-line to the seam-edge of the collar. Shape from 4 through 5 to 26 as represented by the light solid line.

Mark the shape of the forepart from 26 to 23 and down towards 25, and place the forepart pattern in reversed position on the crease-line, the forepart at 26 touching the crease-line at 26, and 13 on the line from 4 to 26. This establishes 5. Mark along the front-shoulder to the line made by the tracer from 25

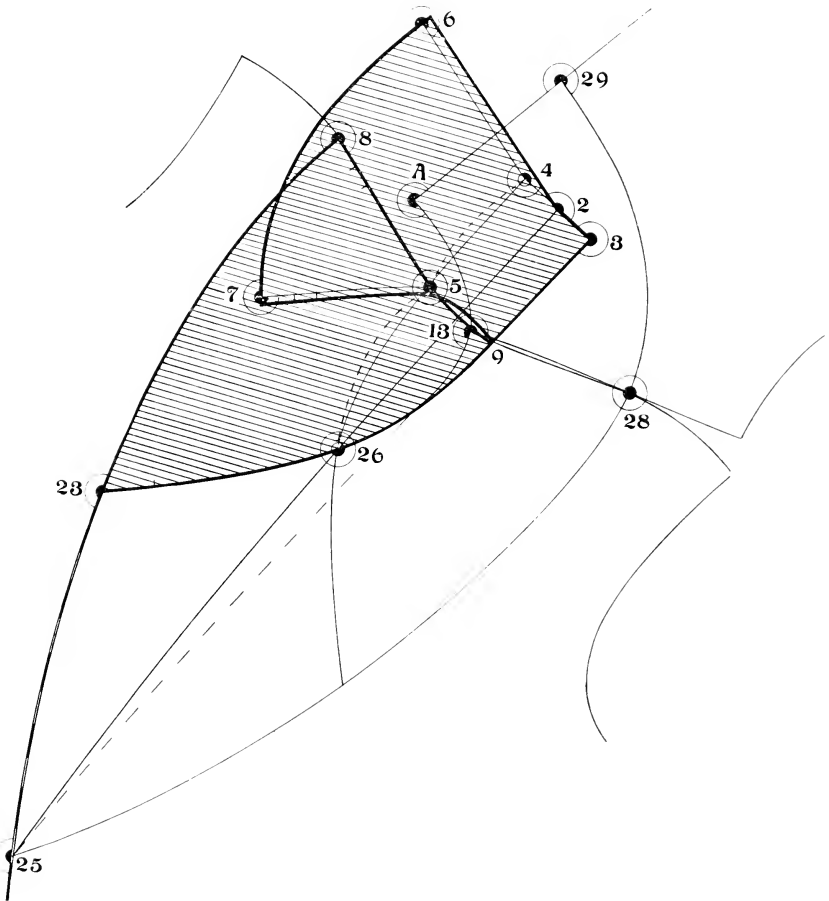

to 28, and along the traced line. This gives the heavy line from 5 to 8 and 8 to 23.

Now lay the pattern for the backpart of the coat in reversed position, with the neck point H at 5, and A at 4. Mark along the center-of-back to 29, which gives point 6; along the shoulder to 28, which gives 7, and from 28 to 29, which gives the heavy line from 6 to 7.

The front section of this collar is represented by points 23, 26, 9, 5, 8 and back to 23. The other section by points 9, 3, 2, 4, 6, 7, 5 and back to 9. Reshape from 2 to  $\frac{1}{4}$  inch backward of 6 and from 9, passing  $\frac{3}{8}$  inch forward of 5, and running thence parallel with the back-shoulder and  $\frac{1}{4}$  inch from it to opposite 7.

Make single notches in collar and forepart near 23 and double notches below 7 and 8. Also make notches at the crease-line on each section.

For heavy, long-haired fur, when a stand is not required, the forepart may be cut on the broken curved line from 25, striking the gorge just backward of 26. In that case the collar would be defined by points A, 29, 28, 25, 13 and back to A.

## THE RAGLAN SLEEVE.

Diagrams 42, 43, 44 and 45.

**D**IAGRAM 42—Draw a straight line as from A to B. Lay the pattern for the backpart with the breast-line directly over the line A B and mark around it above the breast-line from B to the side-seam at L. Establish points 1 and Z the same as on the pattern and remove the pattern.

Draw a line from 1 through Z towards C.

Lay the forepart pattern with the breast-line directly over the line A B and the side-seam to touch the backpart at L. Then mark around it from L, as shown by the broken line, to the front-shoulder point at 13. Mark the scye-notch at 2 and remove the pattern.

Square upward from 2 by the line A B to establish C, and downward towards D. From 2 to E is a full half of the make-up size of the scye. (See explanation for Diagram 34.)

Draw a straight line from 2 through 13 and from Z through H. From 13 to F is 2 inches. From H to G is 1 inch. Pivot at 2 and sweep from F towards I. E to I is the same as Z to G.

Lay the pattern for the backpart with H to touch at I and the line for the Raglan shoulder directly over E. Mark along the top of the back below I (which is shown in a light, broken, circled line), and with a tracer mark the shape of the Raglan

shoulder. This gives the light line from I to E. Remove the pattern and shape the seam from  $\frac{1}{4}$  inch backward of I to E as represented by the heavy line.

Lay the front pattern with point 13 to touch at I and the shoulder-seam against that of the back as represented by the light-circled line. Mark from I to X (which corresponds with

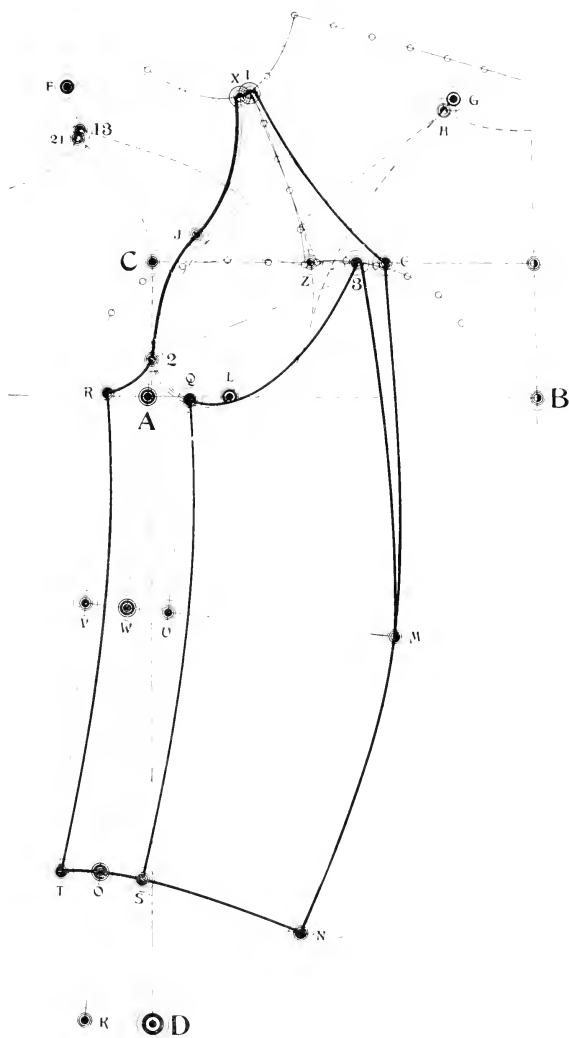

Diagram 42.

13 and 21), and with a tracer mark from X to 20. This gives J. Remove the pattern and shape the Raglan shoulder from  $\frac{1}{4}$  inch forward of X through J to 2 as represented.

Shape the top of the undersleeve from 2 to L as represented  $\frac{1}{2}$  inch above the bottom of the scye.

From 2, following this line past L to 3, is  $\frac{3}{4}$  inch more than the under-arm scye of the coat from 2 through L to Z.

From 2 to D is 24 inches. D to K is  $2\frac{1}{2}$  inches. Connect 2 and K. From A to O is the length. Pivot at E and sweep from O towards N.

A to W is 1 inch less than half way from A to O.

A to Q, A to R, O to S and O to T are each  $1\frac{1}{2}$  inch. Square across from W by the line A O towards M. By the same line square from Q to R and from S to T.

W to M is  $1\frac{1}{4}$  inch more than the size required at the elbow. O to N is  $\frac{1}{2}$  inch more than the size required at the cuff. Connect Q and S to establish U. Connect R and T to establish V.

Shape the top-sleeve from 2 to R and R to T, hollowing from the straight line  $\frac{3}{4}$  inch at V. Shape the backarm-seam from E through M to N, and the bottom from N to T as represented. Shape the undersleeve from Q to S, hollowing  $\frac{3}{4}$  inch opposite U. Add  $\frac{1}{2}$  inch backward of 3, and shape from there to M.

Notch the backpart opposite Z and the forepart and top-sleeve at 2.

Diagram 43—The object of the split-top sleeve is to secure extra length over the point of the shoulder, or more shoulder room than can be obtained by working in of the edges. The shaded part and all below it represents the upper part of the sleeve drafted as explained for Diagram 42. The line from 5 to 6 corresponds with the breast-line.

The line from 3 to 4 is  $\frac{1}{2}$  inch more than  $\frac{1}{3}$  scye above the breast-line. The line from the notch through 5 and 7 is the line A O on Diagram 42.

Lay the pattern over another piece of paper and trace off the part which is shaded. Cut this out and lay it over the draft. With a pencil point pivot the piece at 3 and swing the upper part forward 1 inch as from 1 to 9. Mark from 3 to 9 and across the top.

Now pivot the piece at 4 and swing the upper part of it backward 1 inch as from 2 to 12. Mark from 4 to 12 and across the top.

From 9 to 10, and 12 to 11 are each one-half the quantity between 1 and 2. Point 13 is half way between 3 and 4. Point 14

is half way between 5 and 6. Point 15 is half way between 7 and 8. Shape from 10 and 11 through 13, 14 and 15 to a point central to the width at the cuff, all as represented.

Diagrams 44 and 45 represent the two parts of the top-sleeve which has been cut through on the lines below 10 and 11. This line is correspondingly numbered and is shown by the broken lines below 10 and 11.

From 10 to 13 and 11 to 15 are each a seam's width,  $\frac{1}{4}$  inch, which must be added all the way to the bottom. The heavy, solid lines represent the finished pattern.

The quantity between 13 and 14 and between 15 and 16 represent outlets which may be utilized if at the try-on it is found necessary to provide more neck, shoulder or arm room.

The forepart and backpart may now be cut off on the lines for the Raglan shoulder. It will, however, be advantageous to leave that until after the try-on, having the top-sleeve basted on top of the shoulder.

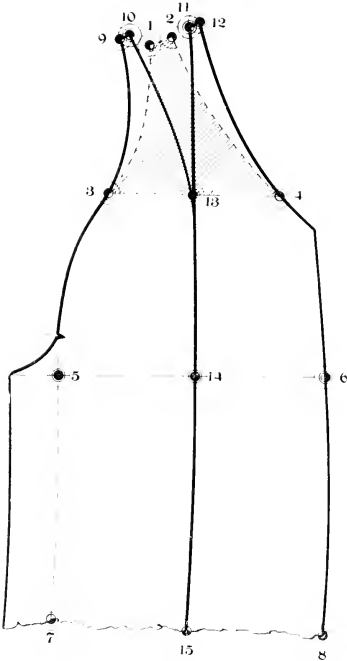

Diagram 43.

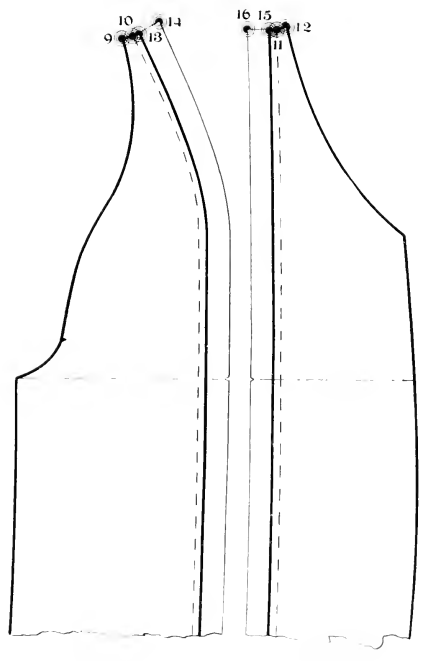

Diagram 44.

Diagram 45.

## FLY-FRONT PALETOT.

### Diagram 46.

THE measures used for the accompanying diagram are the same as found on the "table" for a form of 38 breast taken over the under-coat.

All the points on the backpart excepting 5, 14, D, E, T, O and 2 are obtained in the same manner as explained for Diagram 14.

Connect A and K to establish 5. Connect Z and F to establish 14.

F to T is  $\frac{1}{2}$  inch more than  $\frac{1}{8}$  breast. A to D is  $\frac{1}{4}$  inch more than the fashionable-waist length, and on to E is  $\frac{1}{2}$  inch more than the full length. E to 2 is  $\frac{1}{2}$  inch more than D to O.

All the remaining points on and above the breast-line, excepting H, 18, 19, 20, 21, 22, 25, 23, and 15, are obtained in the same manner as explained for Diagram 14.

R to 23 is 2 inches. F to T and S to U is the back-waist. F to T and U to V is a full half of the waist. V to W is  $1\frac{3}{4}$  inches. Connect 23 and 24, and square downward from 24 to establish N.

Establish the end of the roll and draw the crease-line towards a point  $\frac{3}{4}$  inch forward of the front-shoulder point. Establish points 19, 20, 21 and 22 as explained for Diagram 36, and shape the gorge to 22. This establishes 18.

Point 15 is 3 inches above the breast-line. Make a tracing of the part above 15 and forward of 18 to 22 and 21, pivot this at 15 and swing the upper part forward 1 inch as from 18 to 25. Shape the V below 25 and the rever above the end of the roll passing in good form about  $\frac{1}{2}$  inch forward of 23 as represented.

The collar is  $1\frac{1}{2}$  inch wide at the front and 2 inches at the back.

Square downward from V. From 3 to 12 is  $\frac{1}{6}$  waist. T to 6 is 2 inches, excepting for very stout waisted form, when 2 inches would establish 6 forward of U. In such case T to 6 is the same as T to U.

From 6 to 7 is  $\frac{1}{4}$  breast. From 7 to 8 is the same as U to 6.

Make 14 to 9  $\frac{1}{4}$  inch more than from 14 to O. Point 10 is  $\frac{1}{4}$  inch above the fashionable waist-line. From J to H is  $\frac{1}{4}$  inch less than half-way from J to M. Connect H and 7.

Shape all the parts so far explained as represented. Draw a straight line from 12 through 11.

From 11 to 26 is the same as 9 to 10. Square downward from 26 by the line from 12 to 26.

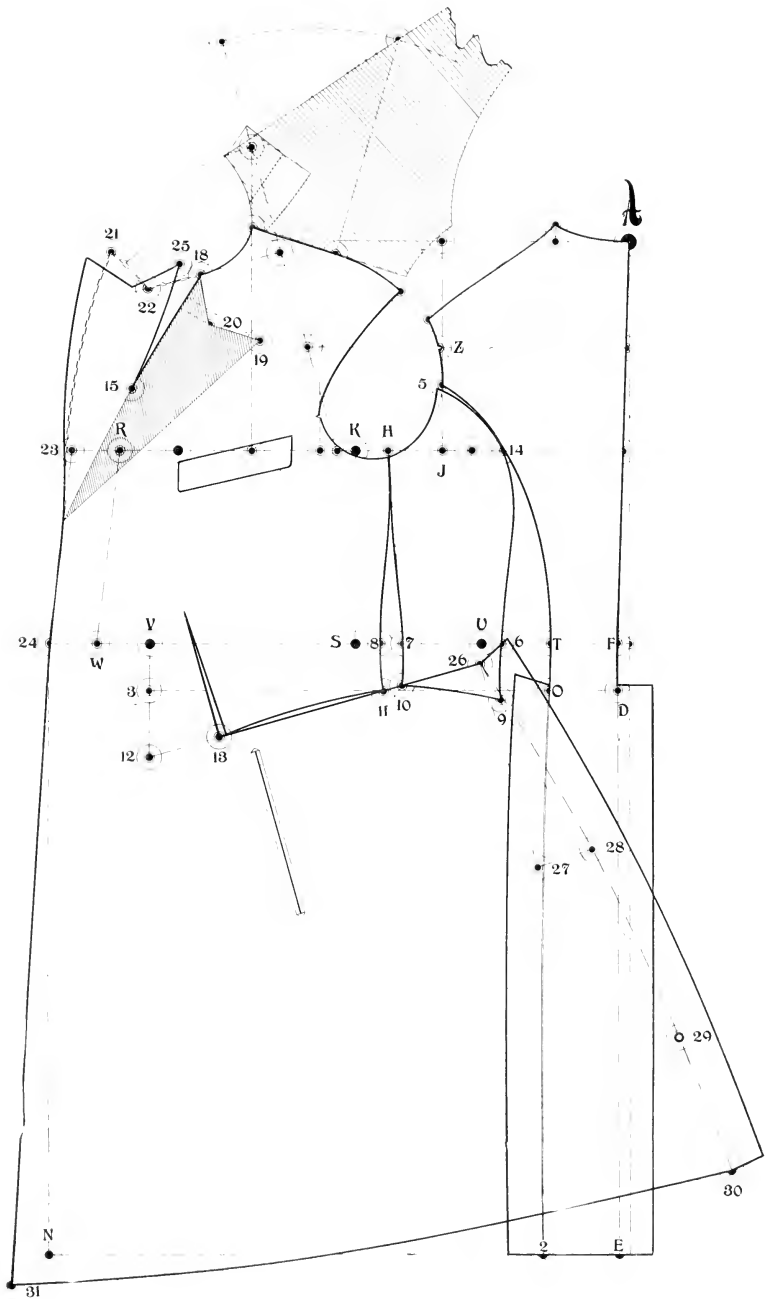

Diagram 46.

From 26 to 27 is 9 inches. Square backward from 27. From 27 to 28 is  $2\frac{1}{2}$  inches. For corpulent forms from 27 to 28 is  $\frac{1}{4}$  inch less than  $2\frac{1}{2}$  inches for each inch that the difference between the waist and seat is less than 5 inches. Draw a straight line from 26  $\frac{1}{2}$  inch forward of 28. From 26 to 29 is 18 inches. Shape the crease-edge from 26 through 28 and 29, and add  $1\frac{1}{2}$  inch for the plait as represented.

From 26 to 30 is the same as O to 2. Point 31 is  $1\frac{1}{2}$  inch below and forward of X. Shape from 24 to 31 and from 30 to 31 as represented.

From 12 to 13 is  $\frac{1}{6}$  breast. Shape the dart as represented, making it  $\frac{1}{4}$  inch wide when the waist is 4 or more inches smaller than the breast, and  $\frac{1}{16}$  inch more than  $\frac{1}{4}$  inch for each inch that the waist is more than a waist which is 4 inches smaller than the breast. Hollow  $\frac{1}{4}$  inch from 11 to 13 as represented.

Square downward by the waist-line about 1 inch backward of 13 for the pocket, and make the opening about  $7\frac{1}{2}$  inches long.

(The diagram is not drawn the full length to obviate excessive reduction.)

## SURTOUT OR NEWMARKET OVERCOAT.

### Diagram 47.

**T**HE measures, as found on the table, by which the accompanying diagram was drafted, are for a form of 40 breast, 37 waist and 42 seat.

This is only **an enlarged frock-coat**. It is drafted in most respects in the same manner as explained for Diagram 14. The skirt has more drapery, or fullness at the sides, caused by the greater amount taken out between I and X.

### To Draft.

All the points on the backpart except T are obtained in the same manner as explained for Diagram 14. F to T is  $\frac{1}{4}$  inch more than  $\frac{1}{8}$  breast, **or to style**.

All the points on the sidebody and forepart excepting 19, 20, 21, 22, 23 and 24 are obtained in the same manner as explained for Diagram 14.

Extend the center-of-front line upward from R to X as represented by the broken line, and as explained for Diagram 36.

From 12 to 24 is  $1\frac{1}{2}$  inch. Draw a straight line upward from 24 for the lapel-seam edge as represented.

R to 23 is 5 inches, **or as style will determine** for the run of the front below the end of the roll. Connect 23 and 24.



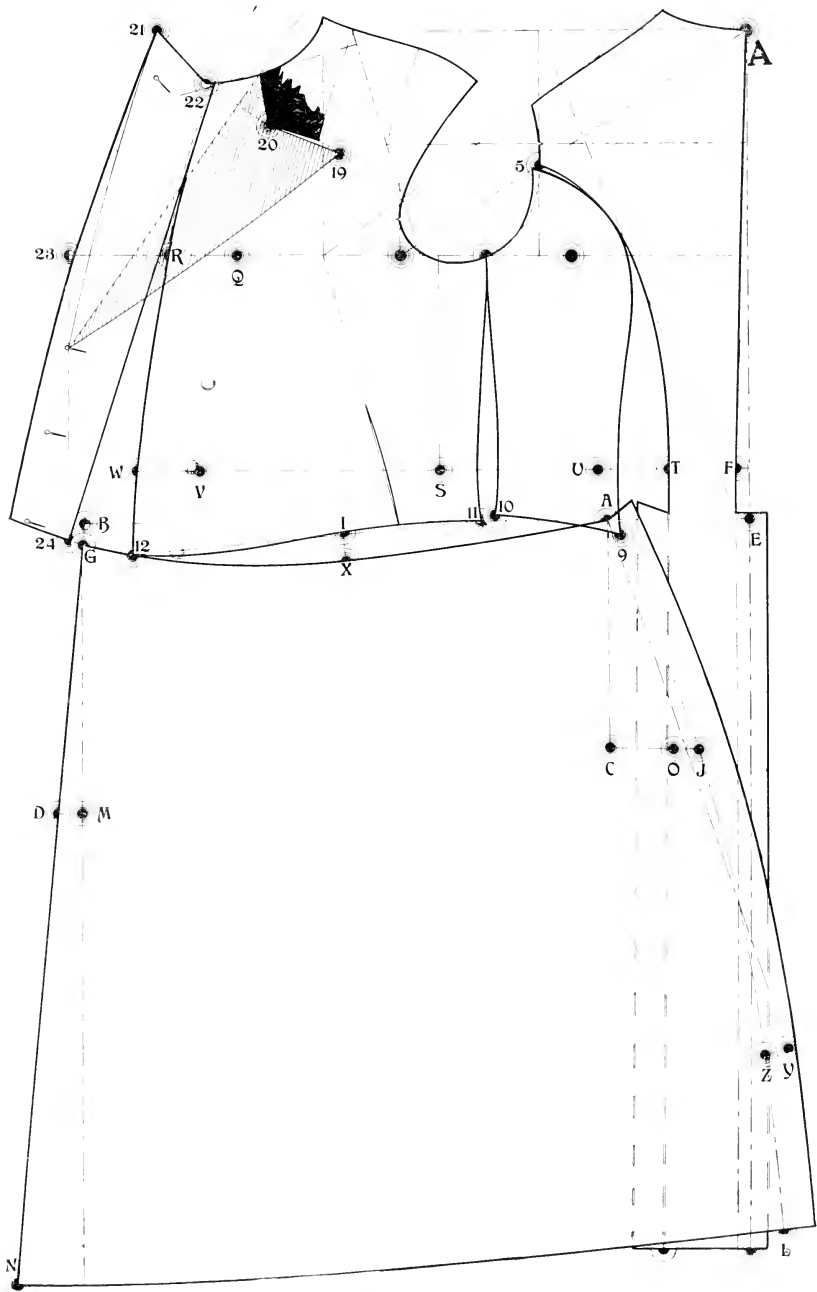

Diagram 47.  
(105)

Establish the end of the roll **according to style**, and draw the crease-line towards a point  $\frac{3}{4}$  inch forward of the front shoulder-point.

Establish **19, 20, 21 and 22 according to style**, and as explained for Diagram 36.

At the bottom the lapel is 3 inches wide, **or to style**. Opposite the end of the roll it is the same as the line from 23 to 24 is forward of the line from R to W opposite the end of the roll. Shape the outer edge of the lapel as represented, **or to style**.

**The Skirt.**—Take another piece of paper and square forward and downward as from A to B and A to C.

From A to B is  $\frac{1}{2}$  inch less than from 9 to 10, 11 to 12 and the width of the lapel at the bottom. Square downward from B.

I is half-way from A to G. I to X is 1 inch, when a considerable amount of fullness is desired at the side. For plainer skirts see the explanations for Diagrams 18, 19 and 20. Shape the waist-seam from A through X, and 12 as represented.

C to O is  $2\frac{1}{2}$  inches when the seat is 5 inches larger than the waist,  $\frac{1}{4}$  inch more than  $2\frac{1}{2}$  inches for each inch that the difference between the seat and waist is more than 5 inches and  $\frac{1}{4}$  inch less than  $2\frac{1}{2}$  inches for each inch that the difference is less than 5 inches.

O to J is the same as I to X. Draw a straight line from A  $\frac{1}{2}$  inch forward of J.

A to Y is 24 inches. Y to Z is 1 inch. Shape from A through J and Z as represented, and add  $1\frac{1}{4}$  inch backward of A J Z for the plait.

A to L is the same as the length of the back-skirt. G to M is the same as G to X. M to D is the same as I to X.

Draw a straight line from G through D and make G to N the same as A to L.

## NOTES.

(Continued from page 33.)

For tall slender forms it is well to draft the coat at least one size larger than the measures, as for a 34 breast draft 36, increasing the waist and seat a like amount, the back and front-scye depths, blade and back-waist  $\frac{1}{2}$  inch, the over-shoulder 1 inch, and  $\frac{1}{2}$  back-width  $\frac{1}{4}$  inch.

Take pains and time when measuring and save time in alterations.

The width of the backpart of a sack-coat is a matter of style. For a close-fitting coat it should be less in width than when only moderately shaped in at the waist. For loose-fitting coats it may be made wider than as shown on the diagrams for sack coats.

Experience alone will give knowledge of the peculiarities of the different materials used. Some are soft and spongy, and work large. Others work small, particularly the cheaper grades of worsteds and silk mixtures. For the class of goods first mentioned and closely woven cloths, cut inside of the chalk-marks, and for the latter class cut well outside.

Always work with well sharpened chalk. Be precise in all matters. Follow the maxim, "Make haste slowly."

Begin this study at the beginning, not at the middle nor finish.

Familiarize yourself by careful and repeated readings with the instructions for taking the measures.

Should difficulties arise, as for example you find that, as a rule, coats are a little full through the blades or in the breast. In such case you should at once take the measures a little closer than formerly across the blade and around the breast. In brief, do not depart from the system as taught for drafting, but take the measures easier or closer as may be required.

Place yourself under the instruction of a practical tailor and learn **how to make a garment**. See that your bushelman has the qualifications of a first-class workman.

## THREE-QUARTER OR MILITARY CAPE.

### Diagram 48.

**S**ELECT a coat pattern of the size required over which the cape is to be worn and proceed as follows:

Draw a straight line as A B.

Lay the pattern of the backpart to touch the line at A, and  $\frac{1}{2}$  inch forward of it at the waist line as represented by the broken lines. Mark from A to C.

Lay the pattern of the forepart with the shoulder seam  $\frac{1}{2}$  inch from that of the backpart, and mark from D to E and towards F. Connect A and E.

G is half-way from A to E. Square out from G.

G to H is  $2\frac{1}{2}$  inches. A to B is the length.

Pivot at H and sweep from  $\frac{1}{2}$  inch above B towards F. Shape the bottom from B. This establishes F.

From the center-of-front line E F such changes may be made (by adding or taking off) as may be required by the current style.

Any style of collar may be applied to the neck as may be desired the same as for a coat.

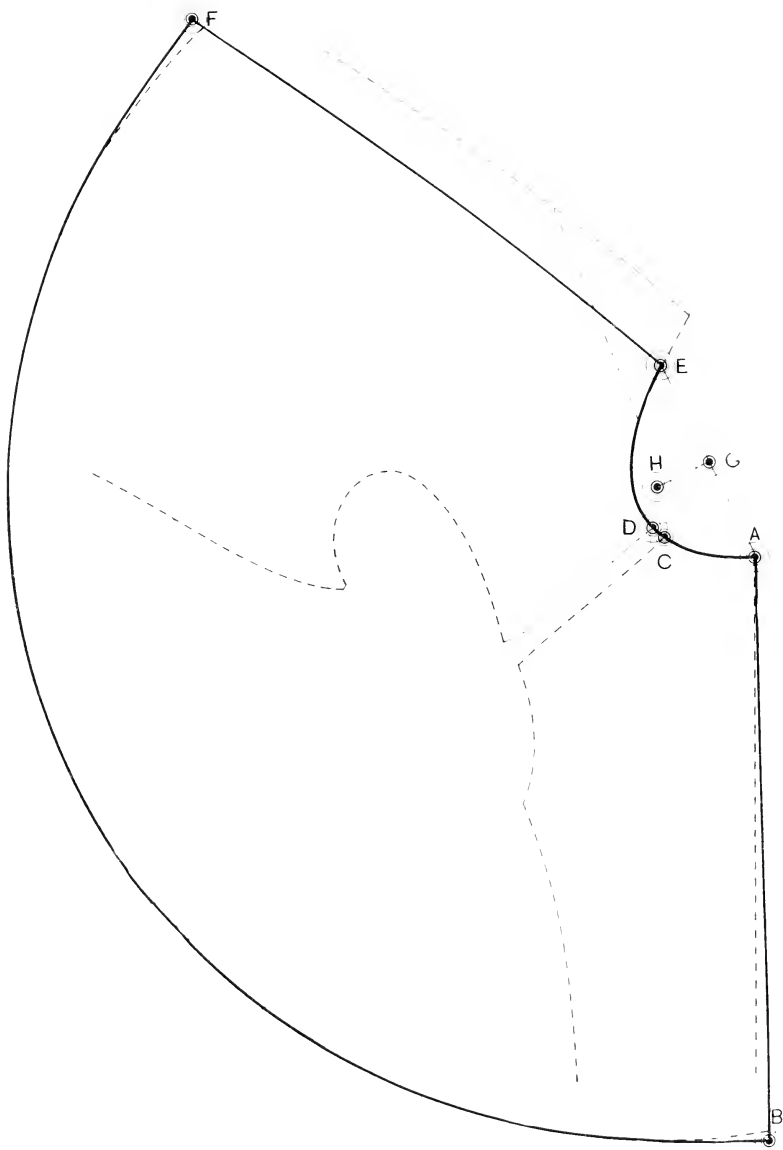

Diagram 48.

## HALF-CIRCLE CAPE.

### Diagram 49.

**T**HE pattern for a three-quarter circle cape of the size required, and which has been drafted as explained for the preceding diagram, is represented by points A B D E and F.

C is half-way from B to F. Connect C and D (the front-shoulder point).

D to G is  $\frac{1}{4}$  breast.

Now lay this pattern over another piece of paper and mark from A towards B and from A to D. Place a pencil-point at G and swing the pattern until the center-of-front line E F is about square with the line A B. D is now at K. Mark by the pattern. This gives the heavy lines from K to J and H.

Connect K and G, and add a seam's width at D and K as represented.

A to B is the length.

Square backward by the line A B from J to establish N.

N to P is 1 inch. Pivot at P and sweep from B to establish H.

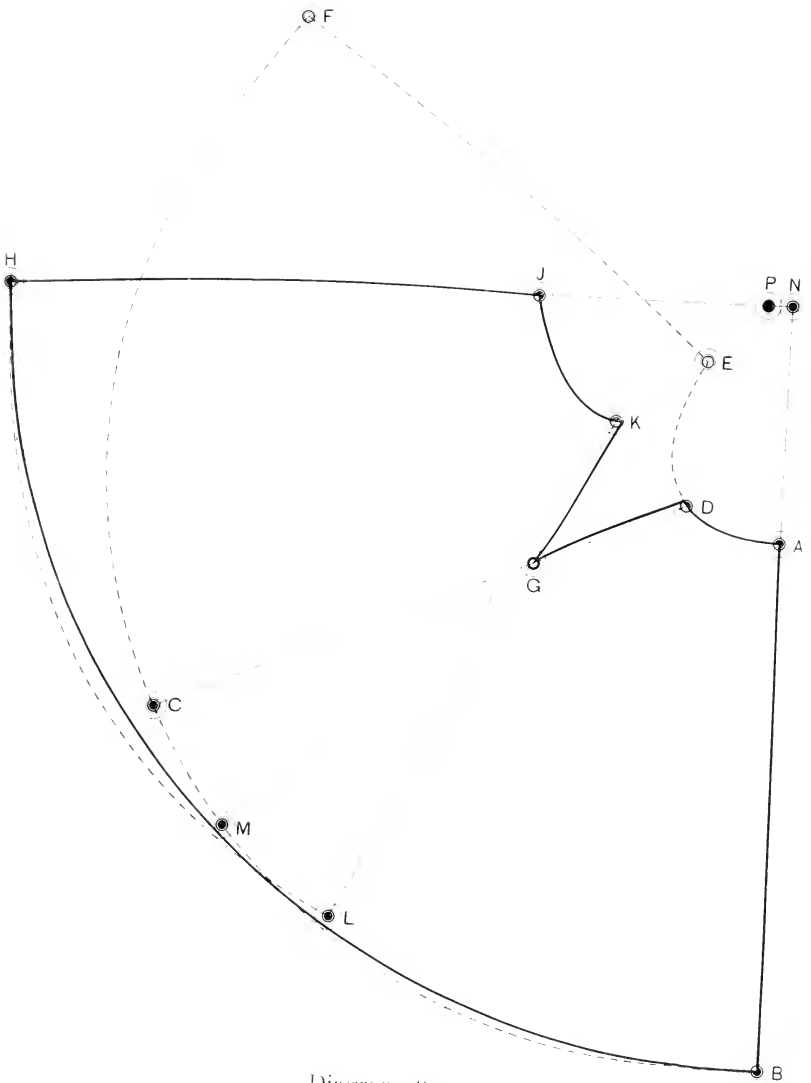

Diagram B.

## CLOSE CAPE.

### Diagram 50.

**T**AKE a pattern for a coat of the size required, lay the forepart and backpart over another piece of paper in the same position as when drafted, and mark the breast-line, also along the back-center, shoulder, scye, front-shoulder, and gorge as represented by the broken lines. Mark the rever crease-line at the gorge, and underneath mark the button-line.

Draw a straight line from A to the bottom of the back-center and remove the pattern.

A to C is  $\frac{1}{2}$  inch more than the length.

D to E is  $\frac{1}{2}$  inch. Pivot 1 inch forward of E and sweep forward from  $\frac{1}{2}$  inch above C towards H. Shape the seam from E through F and the middle of the scye, as at G, as represented.

Square downward from F by the breast-line to establish J.

From the outer shoulder point N to O is  $1\frac{1}{2}$  inch. P is about 1 inch more than half-way from O to the breast-line.

N to Q is 1 inch. Shape from P to O and P to Q.

J to K is the same as J to G. Shape the front-shoulder from M to O and from Q through K towards L, which is as much back of the line falling from J as H is forward of it.

N to O and Q to L is  $\frac{1}{2}$  inch more than E to H. Pivot 1 inch forward of M and sweep forward from L.

The front edge is shaped below M to clear the rever crease-line, and thence just back of the button-line to the bottom.

Make a tracing of the backpart and cut it out all except across the bottom. Then lay the backpart in closed position with the front, H touching L, and reshape the bottom of both parts from C to R as may be necessary to give good form across the bottom. This gives S and T.



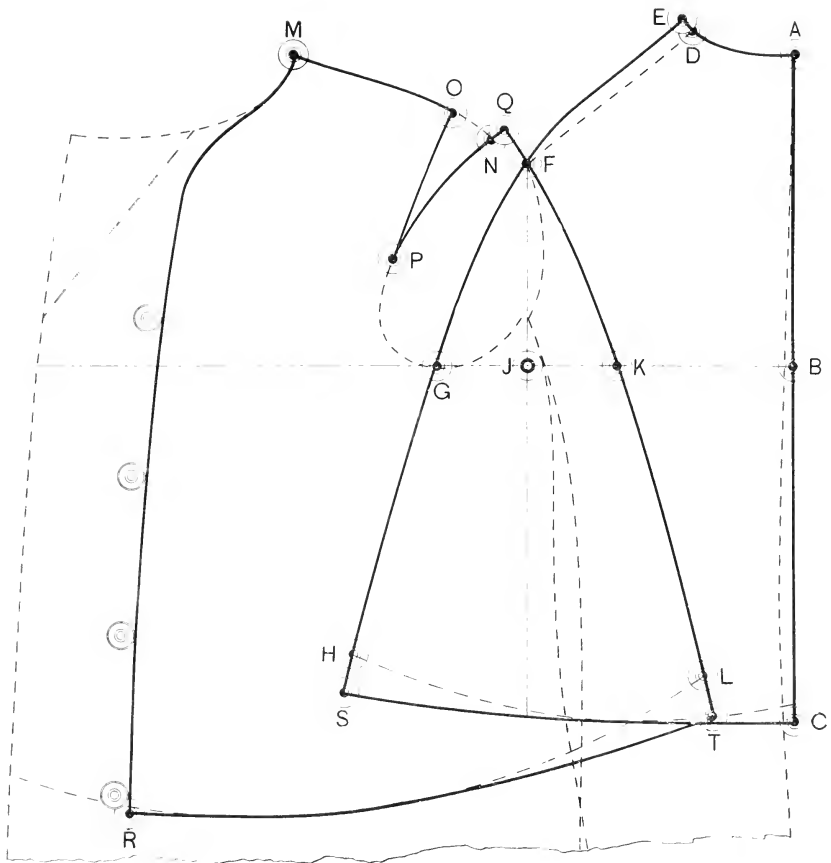

Diagram 50.

## HOOD.

### Diagram 51.

**T**AKE a coat-pattern of the size required, lay the pattern for the backpart to touch a straight line as at B and  $\frac{1}{2}$  inch from the line at the waist, as at D. Mark from B to G and along the shoulder seam.

Lay the forepart pattern with the shoulder seam touching the back-shoulder as represented by the broken lines and mark along the gorge to the center-of-front at H.

B to E is the length. E to D is  $\frac{1}{6}$  breast. Square across from B and D.

B to L is  $\frac{1}{4}$  inch more than  $\frac{1}{3}$  breast. Square upward from L. H to J is 1 inch. Sweep from J pivoting at G to establish K.

D to O is  $\frac{1}{2}$  breast. O to P is 2 inches, **or to style**. Draw a straight line from K to P. M is 1 inch less than half-way from K to P. M to N is 1 inch. Shape the front edge from H through K and N to P. Connect E and P.

B to E is cut on a fold of the material. A hem is usually added from H to P in which a draw string is inserted.

The hood does not always extend to the center-of-front at H. It may be reduced 1 inch or more as from H to J. The shape of the neck seam (B to J or H) is as required when the hood is worn with a coat that buttons to the neck. When the coat has revers the hood should be shaped from B through G to K.

When the hood is to be worn over a cape the cape should first be drafted as explained for Diagram 48. Then lay paper underneath the cape pattern, get the lines B E and B H by the cape, and proceed as above explained.

To draft a hood independent of the coat pattern proceed as follows:

Draw a straight line as A E.

A to B is  $\frac{1}{2}$  inch more than  $\frac{1}{3}$  breast.

B to E is the length. E to D is  $\frac{1}{6}$  breast. Square across from A B and D.

D to O is  $\frac{1}{2}$  breast. O to P is 2 inches, **or to style**.

B to F is  $\frac{1}{6}$  breast. B to L is  $\frac{1}{4}$  inch more than  $\frac{1}{3}$  breast. Square upward from F and L.

F to G is  $\frac{1}{24}$  breast. H is at the center-of-front. H to J is 1 inch, more or less, as desired.

Q is half-way from G to J. Q to R is 1 inch. Shape the neck seam from B through G and R to J or H as represented.

Pivot at G and sweep from J to establish K.

For a coat or cape which closes at the throat, the neck of the hood is shaped as above explained. But where there are revers it is shaped from B to K.

Shape the front edge from H, J or K through N to P and connect E and P.

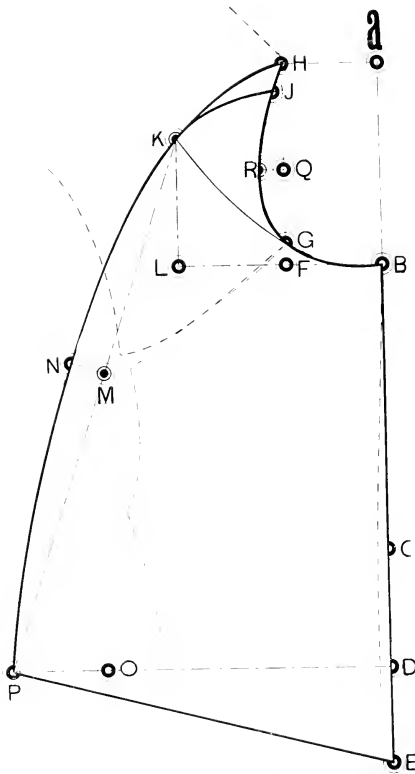

Diagram 51.

**T**HE accompanying table will be found to be well adapted for the production of proportionate patterns and as a **guide to correct measurements**. The measures for a man of any breast size, **whose height is in proportion to his breast**, will not differ materially from those given on the table, unless he differs in development from a normal or average form. For one who is stooping shouldered, the blade and back-scye depth **will be more** and the front-depth **less** than as on the table. For one who has high shoulders, the front and back depths **will both be less**, and for one with low shoulders **more** than as on the table. The table furnishes a basis appropriate for a form of **normal or average development**.

In the first row of figures are given heights ranging from 64 to 76 inches. In the next row are the breast sizes appropriate for the several heights. Then follows the waist, and seat sizes, and other lengths and widths.

The cutter is sometimes required to cut from a few fundamental measures as height, breast, waist and seat. Without a basis of good, safe proportionate measure he would not be able to meet such requirements.

Extensive businesses are being carried on confined exclusively to the making of custom clothing by the use of these fundamental proportionate measures only, and they are conducted with a smaller per cent of misfits and at less cost for alterations than under the conditions which too often prevail in custom cutting. The table furnishes a safe basis by which the cutter can produce suitable patterns for either proportionate or disproportionate forms, also block patterns. He will find it to be of great service, and almost a necessity, in a business of much magnitude.

## HOW TO USE THE TABLE FOR PROPORTIONATE FORMS.

(Taking height, breast, waist and seat only.)

**A** PROPORTIONATE form is one whose height, breast, waist, seat, attitude, slope of shoulder and general development are the same as for a normal or average form of any given breast size.

To draft a proportionate pattern the breast, waist and seat measures and the height only are required.

To obtain the measures by which to draft a coat for a man of, say, 38 breast, and of proportionate height, 70 inches, reference to the table, to the column of figures under 70 in the height row, gives the measures as follows. 38 breast, 34 waist, 39 seat,  $7\frac{3}{8}$  half-back width,  $8\frac{3}{4}$  back-scye depth, 17 natural waist,  $11\frac{1}{2}$  blade,

## PRACTICAL WORKING TABLE of PROPORTIONATE MEASURES

Height.....	64	66	68	70	72	74	76		
Breast over Vest.....	32	34	36	38	40	42	44	46	48
Waist " " .....	28	30	32	34	37	40	42	44	46
Seat .....	33	35	37	39	41	43	45	47	49
Half-Back Width.....	$6\frac{5}{8}$	$6\frac{7}{8}$	$7\frac{1}{8}$	$7\frac{3}{8}$	$7\frac{5}{8}$	$7\frac{7}{8}$	$8\frac{1}{8}$	$8\frac{3}{8}$	$8\frac{5}{8}$
Back-Depth.....	8	$8\frac{1}{4}$	$8\frac{1}{2}$	$8\frac{3}{4}$	9	$9\frac{1}{4}$	$9\frac{1}{2}$	$9\frac{3}{4}$	10
Natural Waist.....	$15\frac{1}{2}$	16	$16\frac{1}{2}$	17	$17\frac{1}{2}$	18	$18\frac{1}{2}$	19	$19\frac{1}{2}$
To Seat Line.....	$22\frac{3}{4}$	$23\frac{3}{4}$	$24\frac{3}{4}$	$25\frac{1}{2}$	$26\frac{1}{4}$	$26\frac{3}{4}$	$27\frac{1}{2}$		
To Crotch.....	$25\frac{1}{2}$	$26\frac{1}{4}$	27	$27\frac{3}{4}$	$28\frac{1}{2}$	$29\frac{1}{4}$	30		
To Center of Thigh.....	32	33	34	35	36	37	38		
To Top of Knee.....	$37\frac{1}{4}$	$38\frac{1}{2}$	$39\frac{1}{2}$	$40\frac{3}{4}$	$41\frac{3}{4}$	$42\frac{3}{4}$	44		
To Sole of Foot.....	56	$57\frac{3}{4}$	$59\frac{1}{2}$	$61\frac{1}{4}$	63	$64\frac{3}{4}$	$66\frac{1}{2}$		
Blade .....	10	$10\frac{1}{2}$	11	$11\frac{1}{2}$	12	$12\frac{1}{2}$	13	$13\frac{1}{2}$	14
Front-Depth.....	$11\frac{1}{8}$	$11\frac{5}{8}$	$12\frac{1}{8}$	$12\frac{3}{4}$	$13\frac{1}{4}$	$13\frac{7}{8}$	$14\frac{3}{8}$	15	$15\frac{1}{2}$
Over-Shoulder.....	$15\frac{3}{4}$	$16\frac{1}{4}$	17	$17\frac{1}{2}$	$18\frac{1}{4}$	$18\frac{3}{4}$	$19\frac{1}{2}$	$20\frac{1}{4}$	21
Sleeve .....	$17\frac{1}{2}$	18	$18\frac{3}{4}$	$19\frac{1}{2}$	20	$20\frac{3}{4}$	$21\frac{1}{4}$		
Back-Waist.....	$6\frac{3}{4}$	$7\frac{1}{4}$	$7\frac{3}{4}$	$8\frac{1}{4}$	9	$9\frac{3}{4}$	$10\frac{1}{4}$	$16\frac{3}{4}$	$11\frac{1}{4}$
Arm-Scye.....	15	$15\frac{1}{2}$	$16\frac{1}{4}$	$16\frac{3}{4}$	$17\frac{1}{2}$	18	$18\frac{3}{4}$	$19\frac{1}{4}$	20
Neck (Coats to button at)....	$15\frac{1}{4}$	16	17	18	19	$19\frac{3}{4}$	$20\frac{1}{2}$	$21\frac{1}{4}$	22
Sleeve at Cuff.....	$11\frac{1}{2}$	12	$12\frac{1}{2}$	13	$13\frac{1}{2}$	$14\frac{1}{4}$	$15\frac{1}{4}$	$15\frac{3}{4}$	$16\frac{1}{4}$
Sleeve at Elbow.....	14	15	16	17	18	$18\frac{1}{2}$	19	$19\frac{1}{2}$	20

12<sup>3</sup>/<sub>4</sub> front-scye depth, 17<sup>1</sup>/<sub>2</sub> over-shoulder, 19<sup>1</sup>/<sub>2</sub> sleeve, 8<sup>1</sup>/<sub>4</sub> back-waist, 16<sup>1</sup>/<sub>2</sub> arm-scye, etc. The table also gives the length to the seat-line (the most prominent part), and the lengths to the crotch, center-of-thigh, top of knee and sole of foot, by which the length can be regulated to any part of the body according to style requirements.

## HOW TO USE THE TABLE FOR DISPROPORTIONATE FORMS.

(Taking height, breast, waist and seat only.)

**A** DISPROPORTIONATE form is one which differs materially from the measurements as given on the table. It may be in height, waist, seat or in attitude. As for example, a form of 68 inches in height, 40 breast, 40 waist and 43 seat. An observation of the shape may, or may not, indicate that the shoulders are more or less sloping, that the blades are more or less full, or that the attitude is different from an average form.

Take for example a form of the height and sizes as given above with blade, slope of shoulder and attitude not noticeably different from an average form. In that case select from the table the lengths to the natural-waist, seat-line, length of coat and sleeve from the column of figures in which 68 is given as height. The back-waist is as given in the column in which 40 is found as the waist size. All the remaining measures except the seat are as found in the column in which the breast size 40 is given. The measures to be used when drafting will then be as follows: 40 breast, 40 waist, 43 seat, 7<sup>5</sup>/<sub>8</sub> half-back width, 9 back-scye depth, 16<sup>1</sup>/<sub>2</sub> natural-waist, 24<sup>3</sup>/<sub>4</sub> seat-line, 39<sup>1</sup>/<sub>2</sub> top-of-knee, 12 blade, 13<sup>1</sup>/<sub>4</sub> front-scye depth, 18<sup>1</sup>/<sub>4</sub> over-shoulder, 18<sup>3</sup>/<sub>4</sub> sleeve, 9<sup>3</sup>/<sub>4</sub> back-waist, 17<sup>1</sup>/<sub>8</sub> arm-scye, etc.

The shoulders may be either higher or more sloping, more erect or more stooping, and the blades may be flatter or fuller than an average form of any given breast size. In the absence of direct measures intelligently taken, or when drafting by the fundamental measures only, the changes to be made are governed by a careful observation of the shape of the form.

**When the shoulders are high**, the back and front depths are each shortened one or two degrees of  $\frac{1}{4}$  inch each, as may seem to be necessary.

**When the shoulders are low**, then the back-depth and front-depth are each lengthened one or two degrees of  $\frac{1}{4}$  inch each, as may seem to be required.

**When the shoulders are high and more erect** than for an average form, then two changes are required. First, the back

and front-scye depths are each shortened one or two degrees of  $\frac{1}{4}$  inch each for high shoulders, and second, the changed front-depth is now lengthened one or two degrees of  $\frac{1}{4}$  inch each for erectness, and the changed back-depth is still further shortened the same amount.

**When the shoulders are erect and low**, the back and front depths are each first lengthened one or two degrees for the increased slope of shoulders. The changed front-depth is then increased, and the back-depth is decreased each one or two degrees of  $\frac{1}{4}$  inch for erectness.

**When the shoulders are high and stooping** the back and front-depths are first shortened one or two degrees for less slope of shoulder. The changed back-depth is then lengthened and the front-depth shortened each one or two degrees for stooping shoulders.

**When the shoulders are more sloping and stooping** than as for the average form, the back and front depths are each lengthened one or two degrees for sloping shoulders. The changed back-depth is then lengthened, and the front-depth shortened each one or two degrees for stooping shoulders.

For a form of any height or breast, if flatter through the blades than the average form, reduce the blade size as found on the table, one, two or three degrees of  $\frac{1}{4}$  inch each as may seem to be necessary. If, on the other hand, the blades are noticeably fuller than for the average form, then increase the blade size one, two or three degrees.

To illustrate further, let us consider what changes would be required to arrange a set of measures for a man of 70 inches in height, 36 breast, 31 waist and 37 seat. An observation of the shape indicates that he is say **one degree erect**, the shoulders are **one degree high**, and the blades are **two degrees flat**.

To find the measures by which to draft, say, a sack-coat for this man, proceed as follows:

First write down the formula for a proportionate form of 36 breast as found on the table and as given in the first row of figures below.

68; 36; 32; 37;  $7\frac{1}{8}$ ;  $8\frac{1}{2}$ ;  $16\frac{1}{2}$ ;  $24\frac{3}{4}$ ; —; 11 —;  $12\frac{1}{8}$ ; 17;  $18\frac{1}{4}$ ;  $7\frac{3}{4}$ .  
 70; 36; 31; 37;  $6\frac{7}{8}$ ;  $8\frac{1}{4}$ ; 17 —;  $25\frac{1}{2}$ ; 30;  $10\frac{1}{2}$ ;  $11\frac{7}{8}$ ; 17;  $19\frac{1}{2}$ ;  $7\frac{1}{2}$ .  
8  $12\frac{1}{8}$

Place under the proportionate height the customer's height, 70 inches, under the waist 32, place his waist size 31. Next consider the front and back depths. These must be treated on the basis of the proportionate height of 68 inches, without regard to the height of the customer. His increased height of 2 inches affects the lengths **from the collar-seam to waist, and from under**

**the arm to the waist only**, both of which are longer than for a form whose height is in proportion to breast, providing of course that the slope of shoulder is the same as for the average form. So that, as the shoulders are one degree high, the front and back-depths are each shortened  $\frac{1}{4}$  inch. This gives  $8\frac{1}{4}$  for the back-depth, which place under  $8\frac{1}{2}$ , and  $11\frac{7}{8}$  for the front-depth, which place under  $12\frac{1}{8}$ .

He is also one degree erect. The changed back-depth must now be shortened another  $\frac{1}{4}$  inch. This gives 8, which we place under  $8\frac{1}{4}$ . The front-depth must also be lengthened  $\frac{1}{4}$  inch for one degree erect. This gives  $12\frac{1}{8}$  again, which is placed under  $11\frac{7}{8}$ .

Next find the length to the natural-waist and seat-line in the column of figures on the table in which 70 inches is given as height. These are respectively 17 and  $25\frac{1}{2}$ . Place these respectively under  $16\frac{1}{2}$  and  $24\frac{3}{4}$ .

The fashionable length is, say,  $21\frac{1}{4}$  inches below the crotch. On the table we find, for a form 70 inches in height, that from the collar-seam to the crotch is  $27\frac{3}{4}$  inches. So the length is fixed as 30 inches, which is placed in its proper order.

In the column for 70 inches height the sleeve length is given as  $19\frac{1}{2}$  inches, which place under  $18\frac{3}{4}$ .

The blade is two degrees flat. So deduct  $\frac{1}{2}$  inch from the proportionate size. This gives  $10\frac{1}{2}$ , which is placed under 11.

The breast, seat, over-shoulder and arm-scye are the same as for a proportionate form.

The half-back width is increased or decreased one-half of the increase or decrease of the blade. So that in this case it is decreased  $\frac{1}{4}$  inch. This gives  $6\frac{7}{8}$ , which place under  $7\frac{1}{8}$ .

The back-waist is the same as for a form of 31 waist,  $7\frac{1}{2}$  inches. Place this under  $7\frac{3}{4}$ .

The measures as used when drafting will then be as follows: 36; 31; 37;  $6\frac{7}{8}$ ; 8; 17;  $25\frac{1}{2}$ ; 30;  $10\frac{1}{2}$ ;  $12\frac{1}{8}$ ; 17;  $19\frac{1}{2}$ ;  $7\frac{1}{2}$ .

It will be observed in this case that shortening the front-depth one degree for high shoulder, and then lengthening it for one degree erect, leaves this length as it was originally. The back-depth has been shortened  $\frac{1}{2}$  inch ( $\frac{1}{4}$  inch for one degree high shoulders and  $\frac{1}{4}$  inch for one degree erect).

**All the sizes given on the table are make-up sizes.** To these allowances are made for seams and ease as previously explained.



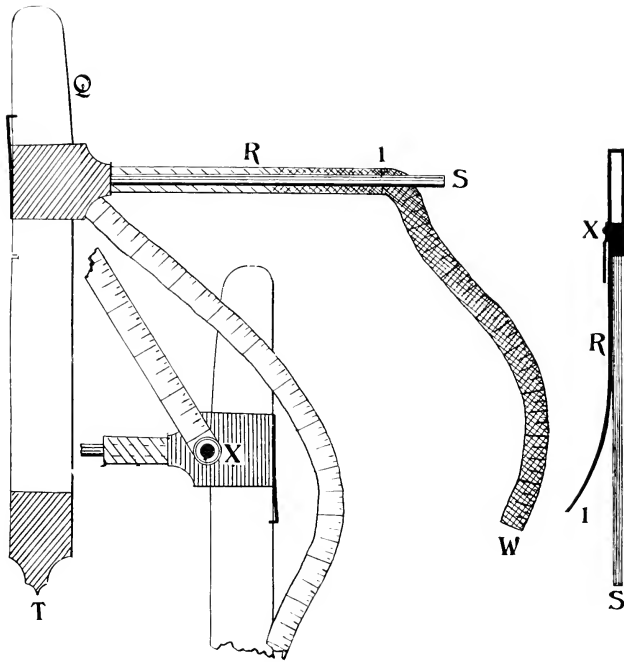

THE MEASURING DEVICE.

THE accompanying cut shows the adjustment of the removable arm "S" for measuring the left side. The portion of a tape-measure is fastened to the end of the spring "R" at I, and must be so adjusted that when a drafting-square is laid along the arm or spring "R" with the angle of the square against "Q," the figures on the tape will be directly opposite the corresponding figures on the drafting-square.

Underneath is shown the reverse-side of the device. To the swivel "X" is fastened another portion of a tape-measure so adjusted to the swivel that when the drafting-square is laid upward along the edge marked "Q" with the angle of the square even with the arm "S" the figures on the tape will be directly opposite the corresponding figures on the square.

When occasion arises that the right side is to be measured, reverse the position of the movable arm so that the swivel will be on the side of the device towards you (the side shown on the left of the cut).

## HOW TO MEASURE.

### The Breast Measure.

**T**HIS measure should be taken **fairly close**, over the vest, the tape passing **well up over the blades**. Observe that the client breathes naturally, and does not expand the chest.

### The Waist Measure.

This measure should be taken **fairly close**, over the vest at the natural-waist, straight around the body.

### The Seat Measure.

This measure should be taken **fairly close**, over the trousers at the most prominent part of the seat, the pockets having been relieved of any bulky matter, and the client standing with heels together.

### The Half-Back Width.

This measure is taken from the center-of-back about 3 inches above the back-scye depth to the sleeve seam directly opposite.

Now place the measuring-device under the left arm in the position shown on Figure 1. The edge lettered "Q" rests against the front shoulder, and is in perpendicular position. The arm lettered "S" just touches the bottom of the scye. It is held in this position by allowing the pointed end "T" to slightly puncture the vest at the side of the waist. Being quite certain that the device is in the position described, and the arm "S" is **level with the floor**, extend the tape which is attached at "I" straight across the blade, and make a light chalk-mark on the upper edge of the tape at the center-of-back, as at B.

Make a mark at the natural-waist and center-of-back as at C.

Make a mark at the collar-seam and center-of-back, as at A. This should be about 1 inch below where it is desired that the crease-edge of the collar shall be.

### Back-Scye Depth.

Place the end of the tape-measure at the mark made for the collar-seam A, and measure to the mark made at the depth-of-scye, B.

### Length to Natural-Waist.

Still holding the tape at the collar-seam measure to the mark made at the natural-waist, C.

### **Seat-Line.**

Still holding the tape at the collar-seam measure to the most prominent part of the seat, D.

### **Length.**

Still holding the tape at the collar-seam measure for the full length desired.

### **The Blade Measure.**

Extend the tape which is attached at "1" and take the measure from the front of scye to the center-of-back, B, as shown on Figure 1. (The center-of-back should be located accurately. Do not be misled by the position of the center-back seam of the vest, which may be drawn to one side of the center-of-back.)

### **Front-Scye Depth.**

Extend the tape which is attached to the swivel upward over the front shoulder and take an **easy** measure to the collar seam A at centre-of-back, as shown on Figure 2.

### **Over-Shoulder Measure.**

Extend the same tape over the middle of the shoulder in a **direct line** to the mark made for the back-scye depth and at the center-of-back, B. This must be an **easy measure**. It is shown on Figure 3.

### **The Sleeve.**

Extend the tape which is attached to the swivel downward and measure to within 1 inch of the knuckle-joint of the thumb for the sleeve length.

### **Back-Waist.**

Place the end of the tape-measure opposite the back-edge of the measuring-device lettered "Q" at the natural-waist and measure straight across to the center-of-back and natural-waist, C, as shown on Figure 5. Remove the measuring device.

### **Arm-Scye.**

This measure is taken easy around over the shirt at the juncture of arm and body as shown on Figure 6.

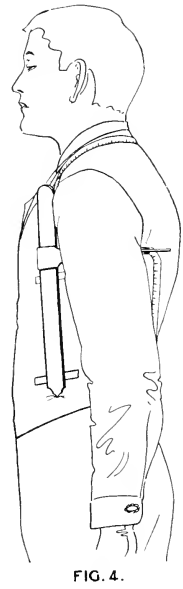
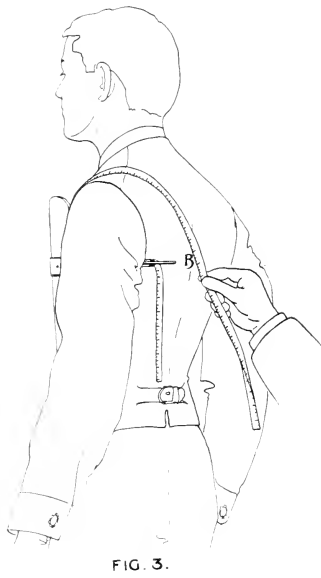
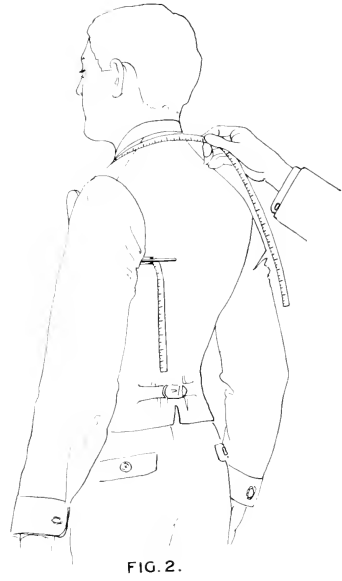
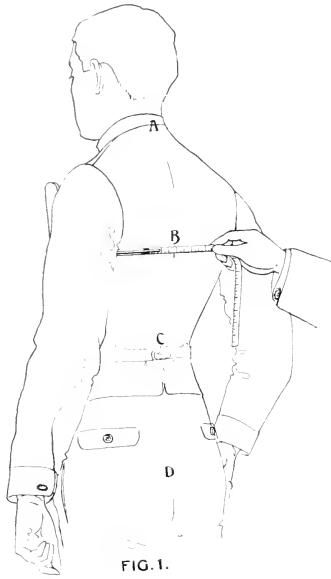

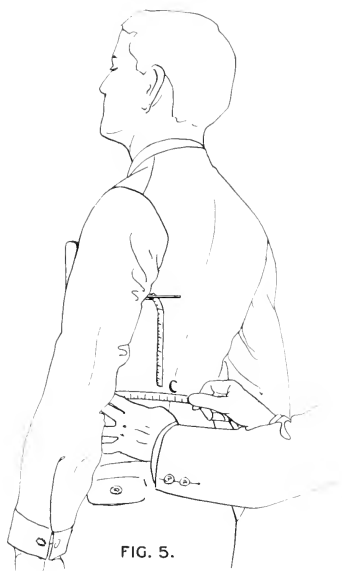

FIG. 5.



FIG. 6.

### CLERICAL COATS, ETC.

For all coats that close at the neck two additional measures are required, viz., half-size of neck and depth of gorge. For the first place the end of the tape-measure at the collar-seam and center-of-back and measure close around over the vest to the front-center at the depth desired for the front of the gorge. Then, still holding the tape as before, bring it down to the center-of-front just below the breast-line. Hold it there, release it from the back of the neck and extend it directly upward and call off the figures on the tape where it intersects with the point first established for the half-size of neck.

**Notes.**—Notice if one shoulder is more sloping than the other and make memoranda of any peculiarities in the shape which are not indicated by the measures.

For frock-coats the measure to the seat-line is omitted.

Always bear in mind that the breast, waist and seat measures are to be taken **fairly close, but not tight**. All other measures are to be taken **just fair, or easy measures**.

## VESTS.

Besides the breast, waist, back-scye depth, front-scye depth, blade, over-shoulder and back-waist measures as taken for a coat, the following additional measures are required, viz.:

Place the end of the tape-measure at the center-of-back and collar-seam, bring it over the front-shoulder and measure to the point at the center-of-front where you desire the **opening** to be. Then, still holding the tape at the back of the neck, extend it down past the front of the arm and measure to the **natural-waist at the side**. Then, still holding the tape at the back of the neck, measure to the length desired **at the center-of-front**. Take all measures in as direct lines as possible.

For corpulent forms an additional measure may be taken on a line from the center-of-back at the natural-waist all around the body direct to the front-length.

For clerical vests take the half-size of neck and depth of gorge in the same manner as explained for clerical coats except that they are taken **under the vest**.

## TROUSERS.

Relieve the pockets of any bulky matter; draw the trousers well up in the crotch (having the client hold them there by the suspenders), and see that the private parts are dressed either right or left.

Place the end of the tape-measure just over the right hip-bone and measure first to the knee and then on to the heel-seam of the shoe for the **outside seam**.

Then place the end of the tape with the left hand close up under the crotch, and measure to the heel-seam of the shoe for the **inside seam**.

Take the **waist measure** fairly close over the waistband and just above the hip bone.

Take a **fairly close seat measure** over the largest part.

Take the sizes for **knee and bottom** according to the prevailing style.

For corpulent forms an additional measure may be taken to find the height in front by placing the end of the tape at the height desired for the waistband seam at the center-of-front, and measuring in a direct line to the heel-seam on the outside of the shoe. Apply this measure when drafting from the bottom of the outside seam upward to the center-of-front.

When **close-fitting legs** are in vogue, take an intermediate measure at the largest part of the thigh and another around the

calf of the leg, noting the distances below the waist where these measures are taken.

Consult the client and learn his wishes in regard to their being close or easy at the seat and waist, and make memorandum. If easy, make the increase when drafting. Do not take the measures sometimes close and sometimes easy.

## SINGLE-BREASTED NO COLLAR AND NOTCH-COLLAR VESTS.

### Diagram 52.

**T**HE measures used for the accompanying diagram are as follows, viz.: 34 breast, 30 waist,  $8\frac{1}{2}$  back-scye depth,  $16\frac{3}{4}$  natural waist,  $10\frac{1}{4}$  blade,  $11\frac{3}{4}$  front-scye depth,  $16\frac{1}{2}$  over-shoulder,  $7\frac{1}{4}$  back-waist, 12 opening,  $19\frac{1}{2}$  side-length to natural-waist, 26 front-length.

### To Draft.

Square the lines A D and A F.

Place the end of the tape-measure  $\frac{1}{4}$  inch below A, and mark the back-scye depth at B and the natural-waist at C.

Point 1 is half-way from B to A. Square across from 1, B and C.

C to E is  $\frac{1}{2}$  inch. Shape from A through B and E, rounding outward a trifle between A and B and inward a trifle from B to E as represented.

A to F is  $\frac{1}{6}$  breast. F to 2 is  $\frac{1}{24}$  breast.

B to G is the blade. G to H is  $3\frac{1}{4}$  inch. G to 3 is 2 inches.

G to J is  $1\frac{1}{4}$  inch more than  $\frac{1}{6}$  breast.

B to K is a full half of the breast. K to L is  $2\frac{1}{2}$  inches.

Square upward from 3 and J and downward from G.

E to O is  $\frac{1}{2}$  inch more than  $\frac{1}{2}$  waist. P is half-way from B to L. Shape the sideseam from P through O towards Z as represented.

Connect 2 and J. From 2 to 4 is  $\frac{1}{4}$  breast. Shape the scye from 4 to the bottom of the scye, sinking it  $\frac{1}{2}$  inch below P.

H to Q is  $3\frac{1}{4}$  inch more than the front-scye depth. H to R is  $3\frac{1}{4}$  inch more than the over-shoulder. Pivot at H and sweep forward from Q.

Connect H and Q to establish 5. Pivot at 5 and sweep backward from R.

M to N is the back-waist. N to U is a full half of the waist. U to V is  $2\frac{1}{4}$  inches.

Cut out the backpart and lay point 2 on the line above J.

A on the sweep-line from Q, and B on the sweep-line from R, as at the light-center circled disk. This establishes S. Connect the circled disk and 5.

Establish 6,  $\frac{1}{4}$  inch from the back-shoulder, and draw a straight line from S through 6. S to 7 is the same as 2 to 4. Finish the scye below 7 as represented.

Place the end of the tape-measure at Q, and extend it through S. Pivot it at S and sweep at T, 2 inches more than the opening, at X, 1 inch more than the side-length to natural waist, at Y, 3 inches below X, and at W, 1 inch more than the front-length.

V to X is 1 inch more than  $\frac{1}{2}$  waist. Shape the sideseam from P through X springing out towards Y. Shape the front below T and the bottom as represented, **or to style.**

P to Z is  $\frac{1}{4}$  inch more than P to Y. C to D is 1 inch less than O to Z.

S to 10 is 1 inch. For a vest with a flat collar, shape the opening from 10 to T and continue the line up towards 9 as represented by the heavy line. S to 8 is the same as A to 2. From 9 to 8 is 1 inch. Cut out the forepart all except on the shoulder-seam, space for the buttons and locate the pockets as represented.

To draft the collar lay the pattern of the forepart over another piece of paper and mark by it from 9 to T and just past T. Also mark from 9 to 8 and remove the pattern. Shape the leaf-edge below 8 to  $\frac{1}{2}$  inch below T to taste or style, and cut the shoulder from 7 to 10.

For a collarless vest the projection from 10 to 9, 9 to 8 and 8 to the shoulder-seam is cut whole with the forepart. Shape the front from 9 to T as represented by the broken line.

Add  $\frac{3}{4}$  inch forward of T and W to the right side for a button-stand as represented by the broken lines.



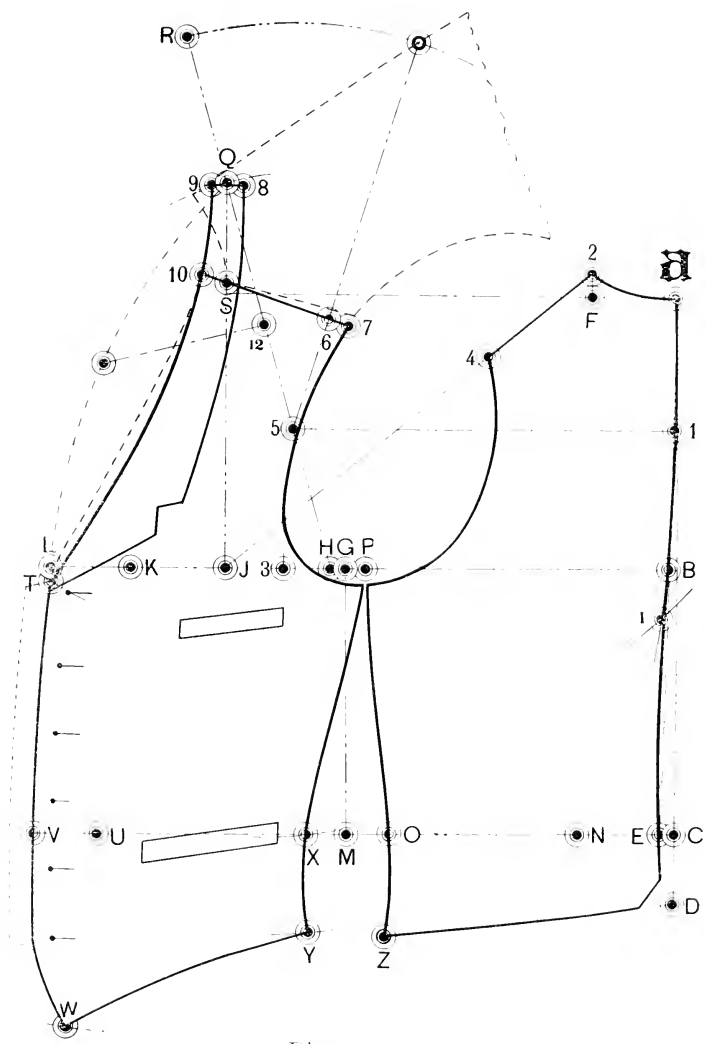

Diagram 52.

## SINGLE-BREASTED VEST.

### Diagram 53.

**T**HIS vest differs from the one shown on the preceding diagram only in style.

The backpart is drafted in the same manner as explained for Diagram 52.

All the points on the forepart, excepting 2, 3 and 4 are obtained in the same manner as for Diagram 52.

Establish points 2, 3 and 4 and shape the collar and front according to style.

The under collar, which is defined by points 8, 9, 2, 3 and just below L is made of silesia or farmers-satin and cut in one piece. The collar facing may be cut whole, but to secure the effect of a coat collar is sometimes made in two sections by cutting the outside, or facing part, across as represented by the broken line from 3 to 4.

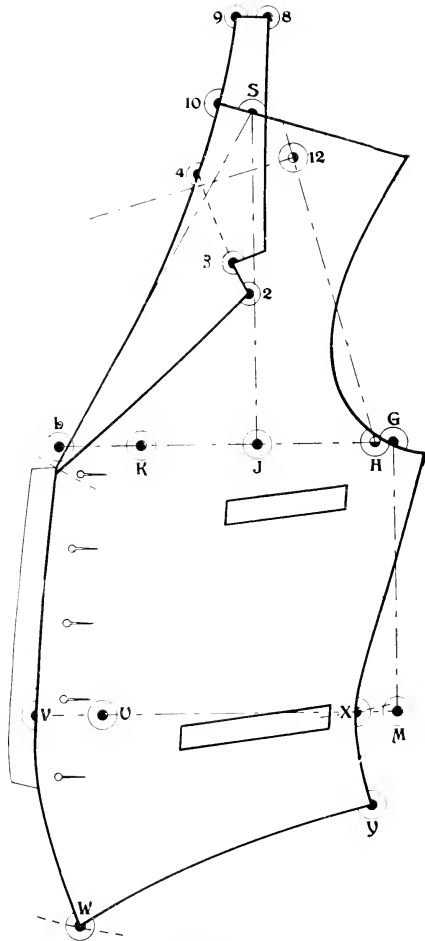

Diagram 53.

## DOUBLE-BREASTED VEST.

### Diagram 54.

**T**HE backpart is drafted as explained for Diagram 52.

All the points on and above the breast-line, excepting L, 2, 3, 4, 5, 6, 7, 8, and 9 are obtained as explained for Diagram 52.

All the points on and below the waist-line excepting V and X are obtained as explained for Diagram 52.

K to L is 2 inches. U to V is  $1\frac{3}{4}$  inches. Connect L and V. The line L V is the center-of-front. V to X is  $\frac{1}{4}$  inch more than  $\frac{1}{2}$  waist.

The width and shape of the front forward of the line L V is governed entirely by **taste or style**. In this instance point 7 has been established 6 inches forward of L, and an outward curved line drawn from 7 to the sweep-line at W as a guide line approximating as near as possible the run of the front according to the style we are trying to copy.

Establish the end of the roll on this line **according to style**, and draw the crease-line from the end of the roll  $\frac{1}{2}$  inch forward of S.

Establish points 2, 3, 4 and 5 **according to style**, and as explained for coats. Shape the gorge from S to 5. This gives 6.

Extend the crease-line towards 8, and make from opposite S to 8 the same as the width of the top of the backpart. Square each way from 8. From 8 to 9 is 1 inch. Shape the collar from 9 to 6, make the leaf  $1\frac{1}{4}$  inch wide at the back and to style at the front end.

From the center-of-front line to the button-line is  $\frac{3}{4}$  inch less than to the front edge. Finish as represented.

Styles are constantly changing. Correct principles do not change. Changes in style affect the length of roll, shape of the rever and collar, the width and shape of the front below the end of the roll. No matter what the shape may be, establish W on the sweep-line **in its style position, make the width opposite the end of the roll also to style**, and proceed as above explained.

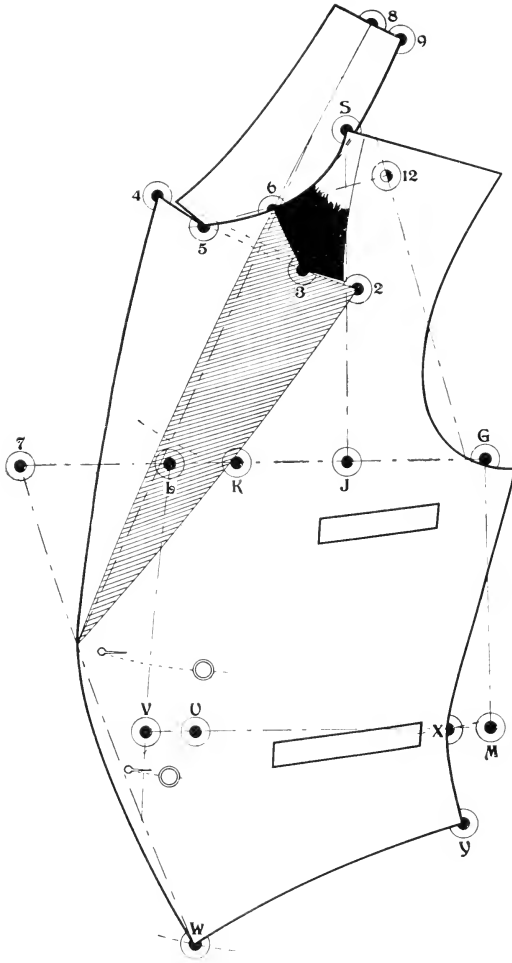

Diagram 54.

## CLERICAL VESTS.

### Diagrams 55 and 56.

**D**IAGRAM 55.—The backpart and all the points on the forepart are obtained in the same manner as explained for Diagram 52.

Diagram 56.—The backpart and all the points on the forepart, excepting 1, 2, 3 and R are obtained as explained for Diagram 52.

Q to R is  $\frac{1}{4}$  breast. (R corresponds to 12 on the preceding vest diagrams.) Square forward from R.

Sweep from L to Q, finding a pivot as at I just below B on Diagram 52. This establishes the unlettered point on the line squared forward from R.

For the average form point 1 is  $\frac{1}{2}$  inch below and backward of the unlettered point. The two measures for half-size of neck and depth of gorge should be applied to establish 1, as follows:

Place the width at the top of the backpart at S and extend the tape-measure in a direct line to the center-of-front as to V. Hold it at V, release it from S, and extend it upward on the center-of-front. Make a short sweep at  $\frac{1}{2}$  inch above the measure for depth-of-gorge.

Place the width of the top of the backpart again at S and apply the measure for half-size of neck and  $\frac{1}{2}$  inch more along the line of the gorge to a point on the first sweep for depth-of-gorge. The intersection of the two measures establishes 1.

Point 1 is at the center-of-front. (See "How to Measure.")

The collar is shaped rounding about  $\frac{3}{4}$  inch from a straight line from 1 to 2. S to 2 is the same as the width of the top of the backpart. From 2 to 3 is  $1\frac{1}{4}$  inch.

Two front lengths and shapes are shown on these diagrams.

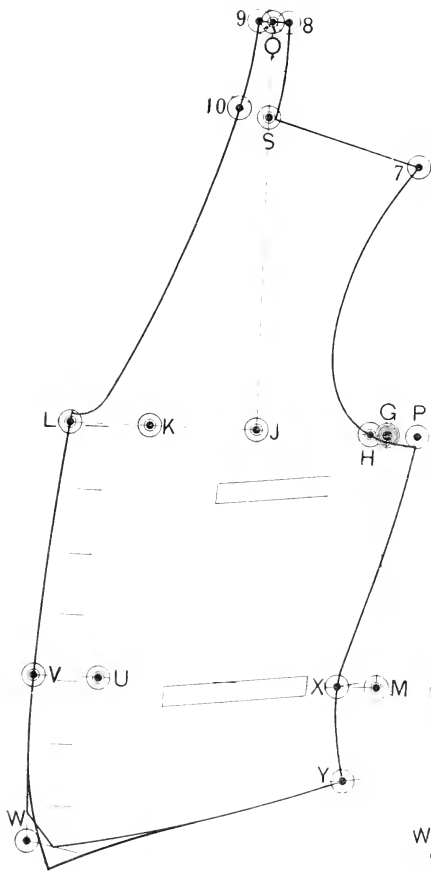

Diagram 55.

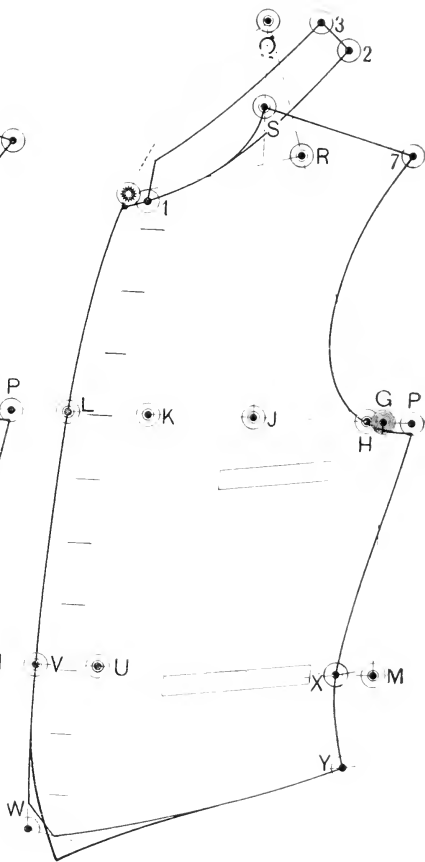

Diagram 56.

## SINGLE-BREASTED VEST.

(Corpulent Form.)

### Diagram 57.

**A**LL the points, excepting 11 and 13, are obtained in the same manner as explained for Diagram 52.

X to 11 is  $\frac{1}{2}$  inch when the waist is as large as the breast,  $\frac{1}{8}$  inch less for each inch that the waist is smaller than the breast, and  $\frac{1}{8}$  inch more for each inch that the waist is larger than the breast.

Y to 13 is  $\frac{1}{2}$  inch more than X to 11.

Two styles of collar are shown on the diagram, a flat collar, represented by the heavy lines, and a creased-shawl collar, by the broken lines.

For the flat collar the shoulder-point is advanced 1 inch as from S to 10. Obtain points 8 and 9, and shape the collar as represented, or to style.

For the creased collar, or collar with stand and leaf, the crease-line is drawn through S. This is represented by the broken lines.

Whenever a collar with a stand is used, then the front-shoulder point remains at S. The collar-seam-edge of the fore-part is shaped as represented by the broken curved line from S to just above T.

Make the stand 1 inch wide at the back, and the leaf  $1\frac{1}{4}$  inch wide.

Two lengths and shapes are shown in front.



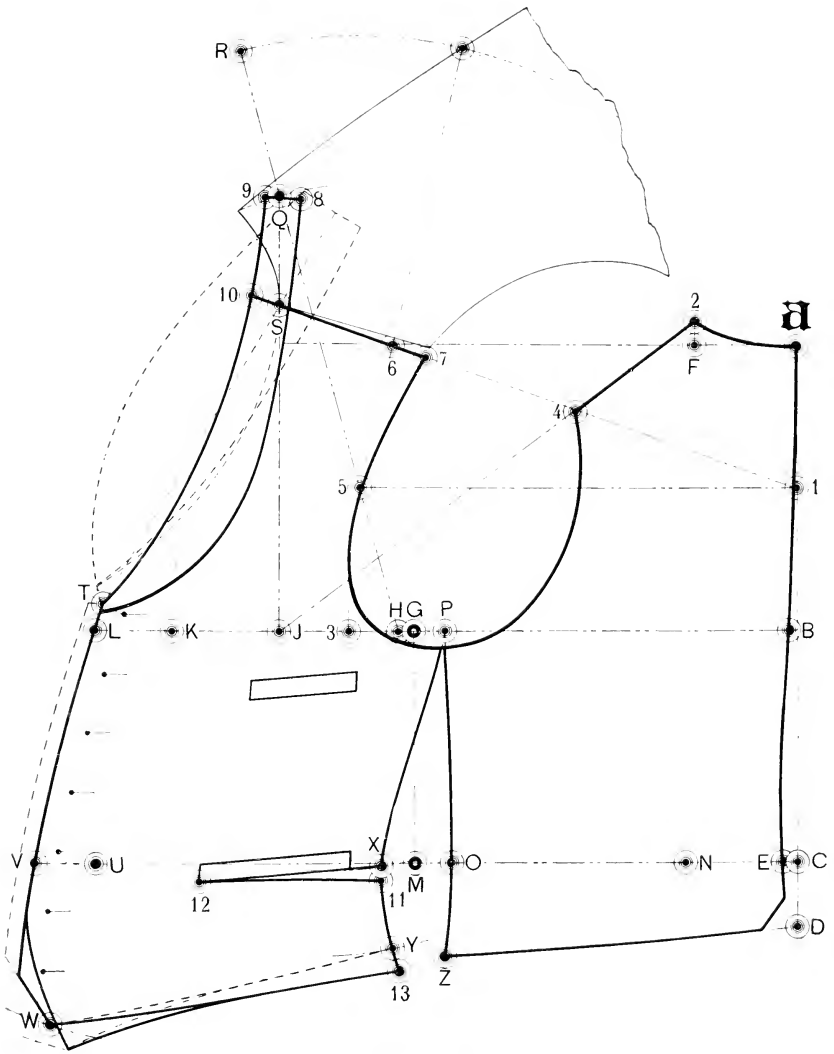

Diagram 57.

## CASSOCK VEST.

### Diagram 58.

**T**HE backpart and all points on the forepart, excepting 1, 2, 4, 5, 6, L, R, V, W, X and the unlettered point just above 6, are obtained in the same manner as explained for Diagram 52.

K to L is 2 inches. U to V is  $1\frac{3}{4}$  inch. Draw a straight line from L through V to W, and sweep from L to a point  $\frac{1}{2}$  inch below Q, finding a pivot as at the unlettered point on the center-back.

Q to R is  $\frac{1}{4}$  breast. Square forward from R.

For an average form point 6 is established on the sweep-line  $\frac{1}{2}$  inch below the light-centered disk at the intersection of the sweep-line with the line squared forward from R. The two measures for half-size of neck and depth-of-gorge should be taken and applied to establish 6, as explained for Diagram 56. (Point 6 corresponds to point 1 on Diagram 56.)

Below L the forepart is usually cut on a fold of the material, in which case V to X is  $\frac{1}{4}$  inch more than  $\frac{1}{2}$  waist. Sometimes it is cut with a seam at the center-of-front, and in such case add  $\frac{1}{4}$  inch from 6 to W for the seam. When there is to be a seam at the center-of-front, then it should be shaped from L to W, rounding slightly forward of a straight line as represented by the broken line.

When the seam is omitted at the center-front, a V should be taken out at the bottom as represented.

The opening is on the right side. The shaded part is sewn on to the right backpart, and the front extends over on the right side as represented by the line from 1 to 2 overlapping the shaded part. The fronts close on the line 1 to 2 with a narrow fly, and the buttons are spaced about 2 inches apart.

From S to 1 is 1 inch. From Y to 2 is  $\frac{3}{4}$  inch. From 1 to 4 and from 2 to 5 are each 2 inches.

**The Collar.**—Of the two diagrams which are shown on the backpart, the one at the left represents the collar as cut. The center-of-front at 4 is cut on a fold of the material, and the opening is on the side at 3. The other diagram shows the collar as it appears when opened out, the crease being represented by the broken line at 4.

From 4 to 3 is the same as the neck-gorge from 6 to 1.

From 4 to 2, at the extreme right on the diagram, is the full size of the neck, less the quantity from 4 to 3.

Add  $1\frac{1}{4}$  inch beyond 2 for a button-stand.

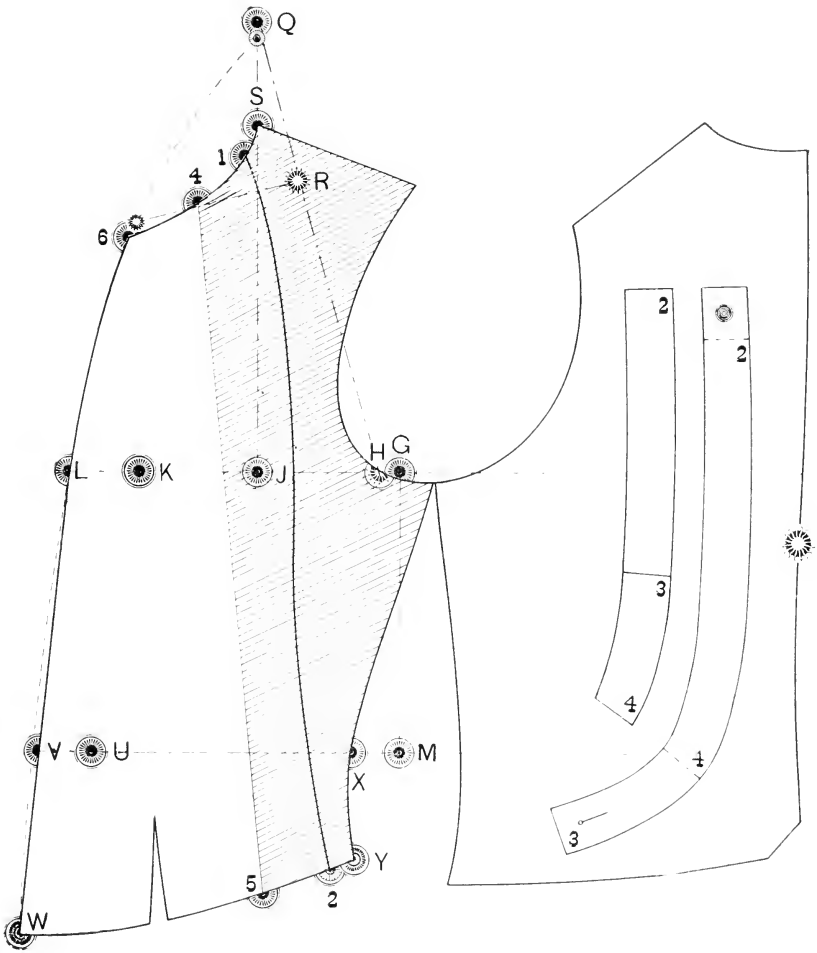

Diagram 58.

## SINGLE-BREASTED DRESS VEST.

### Diagram 59.

THE backpart and all the points on the forepart, excepting 2, are obtained in the same manner as explained for Diagram 52.

From 8 through S to 2 is  $\frac{3}{4}$  inch more than the measure for the opening. Shape the flat collar as represented.

The shoulder-seam extends across from 10. The under-collar, made of farmers-satin or silk, is represented by all that part below 8 and 9 to 2. The facing is cut the same shape as the under collar, except that it is cut a seam's width wider below 8, and on the crease-edge below 9 it is cut sufficiently wider to turn and form a facing on the under side. It should be about  $\frac{3}{4}$  inch wider opposite 9, and gradually wider to about  $1\frac{1}{2}$  or 2 inches wide at and below the top button.

The Flat-Collar Facing—Lay the under-collar over another piece of paper and mark all around it as represented by the part which is heavy shaded and defined by points 2, 3 and 4.

Lay the pattern for the forepart in closed position with the under-collar at 4. The position of the forepart is represented by broken lines.

Add for the turn-ins, as represented by the heavy lines, at least  $\frac{1}{4}$  inch beyond the end (2 to 3), and on the outer edge from 3 past 4 and 5. On the inner edge it should not be less than  $\frac{1}{2}$  inch below 2 and gradually broadening to  $1\frac{1}{2}$  inch opposite and below 4.

Whenever this facing is "Pieced," make the joining well below the top buttonhole.

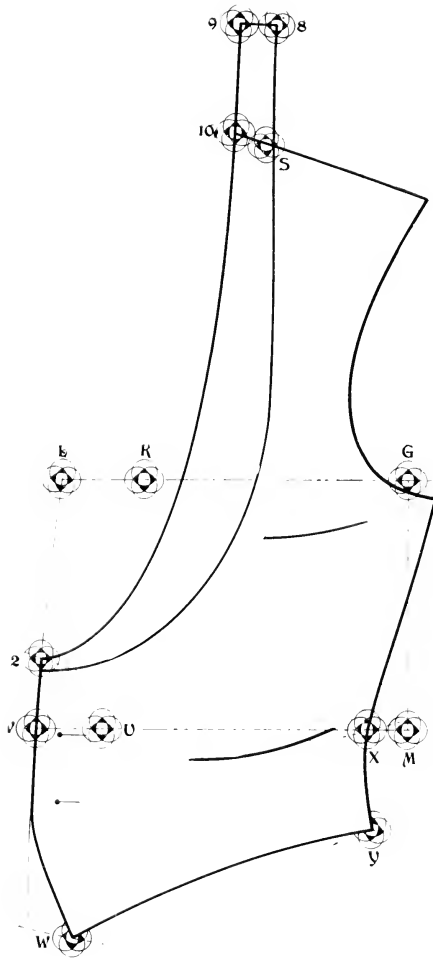
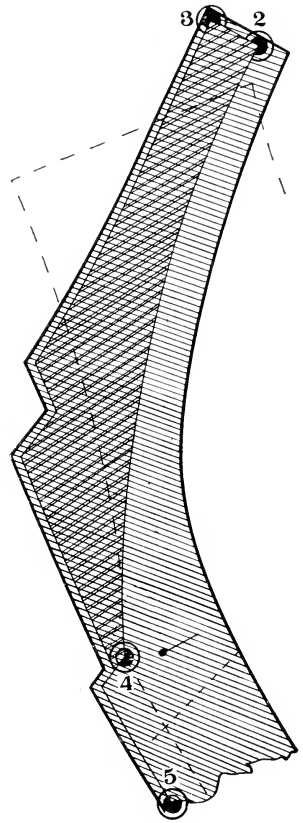

Diagram 59.



## TROUSERS.

### Diagrams 60 and 61.

**T**HE measures used for the accompanying diagrams are as follows, viz.: 24 waist to knee, 42 outside seam, 32 inseam, 32 waist, 38 seat, 19½ knee, 16½ bottom.

#### To Draft,

##### Diagram 60.—The Forepart.

Draw a straight line across the top and square downward as from the heavy circled disk at the hand.

From the circled disk to **G** is the hip-rise. (The difference between the outside and inside seams), 10 inches for this draft. Square forward from **G**.

**G** to **H** is ½ seat, 9½ inches. **H** to **I** is 1/32 seat, full ½ inch. **H** to **J** is ¼ inch less than ⅛ seat, 2⅛ inches. **H** to **K** is ¼ inch less than 1/6 seat, 2⅞ inches.

Square upward from **H** to establish **L**. Connect **I** and **L**.

**B** is half-way from **G** to **J**. Square upward and downward from **B**.

**A** to **D** is the knee-length, and on to **F** is the outside seam length. Square forward and backward from **D** and **F**.

**A** to **O** is ¼ waist, 4 inches. **I** to **N** is 1/6 seat, 3¼ inches. **G** to **I** is the same as **I** to **N**. Connect **N** and **I**. This establishes **M**. Shape from **O** through **M** to **J**, and through **N** to **K** as represented.

**O** to **P** is ½ waist, 8 inches. **D** to **Q** and **D** to **R** are each ¼ knee, 4⅞ inches.

Deduct 3 inches from the size for the bottom and place one-half of the remainder divided equally on each side of **F**. This gives **S** and **T** each 3⅜ inches from **F** for this draft.

Shape the sideseam from **P** through **G** and **Q** to **T**, and the inseam from **J** and from **K** through **R** to **S** as represented.

**F** to **2** depends upon the sizes of the foot and bottom of the trousers. On the diagram **F** to **2** is 1½ inch. Shape the bottom as represented, shortening the same for this style ¼ inch above **S** and **T**.

Cut out the forepart and make notches at **G**, **Q** and **R**.

##### Diagram 61.—The Backpart.

Lay the pattern for the forepart over another piece of paper, extend the line upward above **B**, and the cross lines at the knee and bottom.

Pivot at **G** and sweep backward from ½ inch below **P** towards

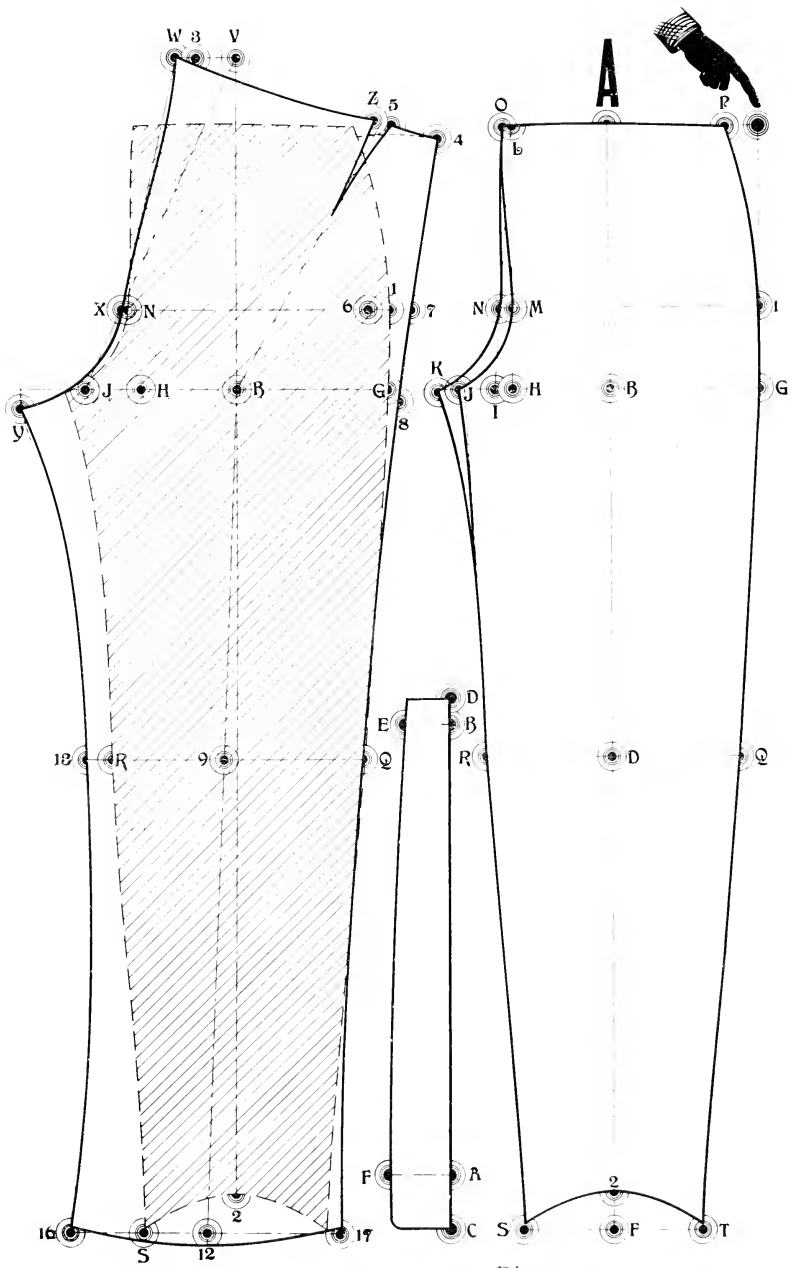

Diagram 61.

Diagram 60.

B to V is  $\frac{2}{3}$  seat,  $12\frac{5}{8}$  inches. Square forward from V.

V to 3 is  $\frac{1}{12}$  seat,  $1\frac{5}{8}$  inch. From 3 to W is  $\frac{1}{24}$  seat, full  $\frac{3}{4}$  inch. Connect J and V to establish X. Connect W and X.

M to 1 on the forepart and X to 6 is a full half of the seat, 19 inches. From 6 to 7 is  $1\frac{1}{2}$  inch.

H to the sweep-line at Y is  $\frac{1}{4}$  seat,  $4\frac{3}{4}$  inches. R to 13 is 1 inch. From 13 to Y is  $\frac{1}{2}$  inch less than R to K on the forepart..

Point 9 is half-way from Q to 13. Draw a straight line from B through 9 to establish 12.

S to 2 and 12 to 16 is  $\frac{1}{2}$  inch more than a full half of the bottom. From 12 to 17 is the same as from 12 to 16.

W to the sweep-line at 4 is 2 inches more than  $\frac{1}{2}$  waist, 10 inches. Connect W and 4. From 4 to 5 is  $\frac{1}{8}$  waist, 2 inches. From 5 to Z is  $\frac{1}{2}$  inch.

Shape from W through X to Y, from Y through 13 to 16, and from 4 through 7 and Q to 17 as represented.

Shape the top as represented.

Shape the bottom, rounding  $\frac{1}{2}$  inch below 12 and  $\frac{1}{4}$  inch above 16 and 17. Cut the pattern and make notches at 13 and Q, also at 8, which is  $\frac{1}{2}$  inch below G.

Q to 8 and 13 to Y are to be stretched to equal Q to G and R to K on the forepart.

The backpart should be well shrunken between B and 9.

**The Waistband.**—Draw a straight line as C D for the seam-edge.

A to B is a full half of the waist. A to F is  $2\frac{1}{2}$  inches. A to C is  $2\frac{1}{2}$  inches. B to D is 1 inch. B to E is  $1\frac{3}{4}$  inch. Make notches at A and B.

For forms that carry the feet well together, see explanation for Diagrams 66 and 67.

## PEG-TOP TROUSERS.

Diagrams 62 and 63.

**T**HE measures used for the accompanying diagrams are as follows:

$22\frac{1}{2}$  knee-length, 40 side-length, 41 front-length, 31 inseam, 34 waist, 38 seat, 22 knee, 16 bottom.

### To Draft.

Diagram 62.—**The Forepart.**

Draw a straight line across at the top and square downward, a3 from the heavy circled disk at the hand.



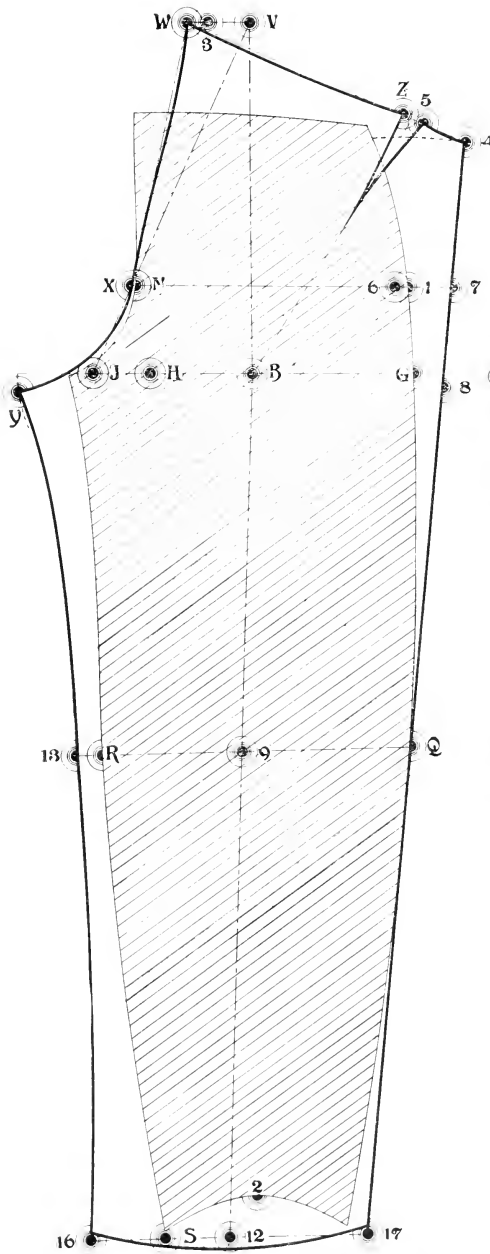

Diagram 63.

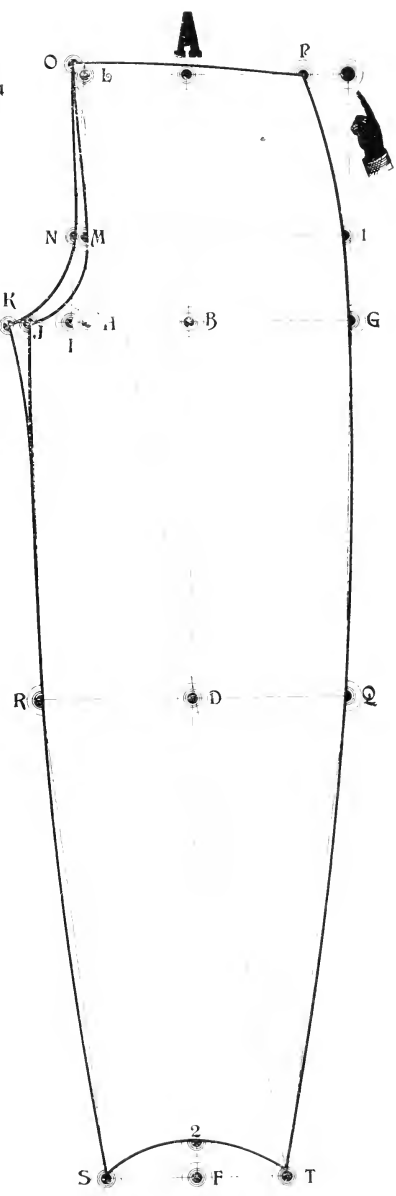

Diagram 62.

From the circled disk to G is the hip-rise. (The difference between the outside and inside seams.) Square forward from G.

G to H is  $\frac{1}{2}$  seat. H to I is  $\frac{1}{32}$  seat. H to J is  $\frac{1}{4}$  inch less than  $\frac{1}{8}$  seat. H to K is  $\frac{1}{4}$  inch less than  $\frac{1}{6}$  seat.

Square upward from H to establish L. Connect L and I.

B is half-way from G to J. Square upward and downward from B.

A to D is the knee-length, and on to F is the outside-seam length. Square forward and backward from D and F.

A to O is  $\frac{1}{4}$  waist. I to N is  $\frac{1}{6}$  seat. G to 1 is the same as I to N. Connect N and 1. This establishes M. Shape from O through M to J, and through N to K as represented.

O to P is  $\frac{1}{2}$  waist. D to Q and D to R are each  $\frac{1}{4}$  knee.

Deduct 3 inches from the size of the bottom and place one-half of the remainder divided equally on each side of F. This gives S and T each  $3\frac{1}{4}$  inches from F.

T to O is the front-length.

Shape the sideseam from P through G and Q to T, and the inseam from J and K through R and S as represented.

The bottom is hollowed about 2 inches above F. Shape the bottom as represented, shortening  $\frac{1}{4}$  inch above S and T.

Cut the forepart and make notches at G, Q and R.

Diagram 63.—**The Backpart.**

Lay the pattern for the forepart over another piece of paper; extend the line above B, and the cross-lines at the knee and bottom.

Pivot at G and sweep backward from  $\frac{1}{2}$  inch below P towards 4.

B to V is  $\frac{2}{3}$  seat. Square forward from V. V to 3 is  $\frac{1}{12}$  seat. From 3 to W is  $\frac{1}{24}$  seat. Connect J and V to establish X. Connect W and X.

M to 1 on the forepart, and X to 6 is a full half of the seat. From 6 to 7 is 2 inches, or  $2\frac{1}{2}$  inches if more ease is desired. (You will note that this is more than as on Diagram 61.)

H to the sweep-line at Y is  $\frac{1}{4}$  seat. R to 13 is 1 inch. From 13 to Y is  $\frac{1}{2}$  inch less than from R to K on the forepart.

Point 9 is half-way from Q to 13. Draw a straight line from B through 9 to establish 12.

From S to 2 and 12 to 16 is  $\frac{1}{2}$  inch more than a full half of the bottom. From 12 to 17 is the same as 12 to 16.

W to the sweep-line at 4 is 2 inches more than  $\frac{1}{2}$  waist. Connect W and 4. From 4 to 5 is  $\frac{1}{8}$  waist. From 5 to Z is  $\frac{1}{2}$  inch.

Shape from W through X to Y, from Y through 13 to 16, and from 4 through 7 and Q to 17 as represented.

Shape the top as represented.

Shape the bottom rounding  $\frac{1}{2}$  inch below 12 from  $\frac{1}{4}$  inch above 16 to  $\frac{1}{4}$  inch above 17.

Point 8 is  $\frac{1}{2}$  inch below G. Cut the pattern and make notches at 8, 13 and Q.

From Q to 8 and from 13 to Y are to be stretched to equal Q to G and R to K on the forepart. The backpart should be well shrunken between B and 9.

The waistband is drafted in the same manner as explained for Diagrams 60 and 61.

For forms that carry the feet more closely together than is usual, see the explanation for Diagrams 66 and 67.

## TROUSERS WITH CLOSE-FITTING LEGS AND SPRING-BOTTOMS.

### Diagrams 64 and 65.

THE measures used for the accompanying diagrams are as follows: 13 outside length to thigh, 24 to knee, 29 to calf, 42 outside length, 42 $\frac{1}{2}$  front-length, 32 inseam, 38 waist, 40 seat, 23 thigh, 17 knee, 17 calf, 20 bottom.

### To Draft.

#### Diagram 64.—The Forepart.

Draw a straight line across near the top of the paper and square downward as from the heavy circled disk marked by the hand.

From the circled disk to G is the hip-rise. (The difference between the outside and inside lengths.) Square forward from G.

G to H is  $\frac{1}{2}$  seat. H to I  $\frac{1}{32}$  seat. H to J is  $\frac{1}{4}$  inch less than  $\frac{1}{8}$  seat. H to K is  $\frac{1}{4}$  inch less than  $\frac{1}{6}$  seat. Square upward from H to establish L and connect L and I.

B is half-way from G to J. Square upward and downward from B.

A to C is the length to the thigh. A to D is the length to the knee. A to E is the length to the calf. A to F is the outside length. Square forward and backward from C, D, E and F.

A to O is  $\frac{1}{4}$  waist. H to M is  $\frac{1}{6}$  seat. Square forward and backward from M. Shape from O through M to J, and through N to K as represented.

O to P is  $\frac{1}{2}$  waist. G to 2 is  $\frac{1}{2}$  inch.

D to Q and D to R are each  $\frac{1}{4}$  knee. Connect G and Q.

Deduct 5 inches from the size of the bottom, and place one-half of the remainder divided equally on each side of F. This gives S and T. Connect Q and T. Connect R and S.

Shape from P through 2 and Q to T, and from J and K through R to S as represented.

Shape the bottom from S to T as represented.

T to O is the front-length. Shape from P to O as represented.

Cut the forepart and make notches at 2, Q and R.

Diagram 65.—**The Backpart.**

Lay the pattern for the forepart over another piece of paper; extend the line above B and the cross lines at the thigh, knee, calf and bottom.

Pivot at 2 and sweep backward from  $\frac{1}{2}$  inch below P towards 4.

B to V is  $\frac{2}{3}$  seat. Square forward from V.

V to 3 is  $\frac{1}{12}$  seat. From 3 to W is  $\frac{1}{24}$  seat. Connect J and V to establish X opposite N. Connect W and X.

M to 1 on the forepart and X to 6 is a full half of the seat. From 6 to 7 is  $1\frac{1}{2}$  inch.

H to the sweep-line at Y is  $\frac{1}{4}$  seat.

From 10 to 11 and 15 to 18 is 1 inch more than the thigh. R to 13 is 1 inch. From U to 14 and 19 to 20 is 1 inch more than the calf.

Point 9 is half-way from Q to 13. Draw a straight line from B through 9 to establish 12.

S to F and 12 to 16 is  $\frac{1}{2}$  inch more than a full half of the bottom. From 12 to 17 is the same as 12 to 16.

From 13 to Y is  $\frac{1}{2}$  inch less than R to K on the forepart.

W to the sweep-line at 4 is 2 inches more than  $\frac{1}{2}$  waist. Connect W and 4. From 4 to 5 is  $\frac{1}{8}$  waist. From 5 to Z is  $\frac{1}{2}$  inch.

Shape between all the points as represented.

Point 8 is  $\frac{1}{2}$  inch below 2. Cut the pattern and make notches at 8, 13 and Q.

From Q to 8 and 13 to Y are to be stretched to equal Q to 2 and R to K on the forepart. The backpart should be well shrunken between B and 9.

The waistband is drafted in the same manner as explained for Diagrams 60 and 61.

For forms that carry the feet more closely together than is usual, the lines below C on the forepart, and below B to 12 on the backpart, should be drawn as explained for Diagrams 66 and 67.

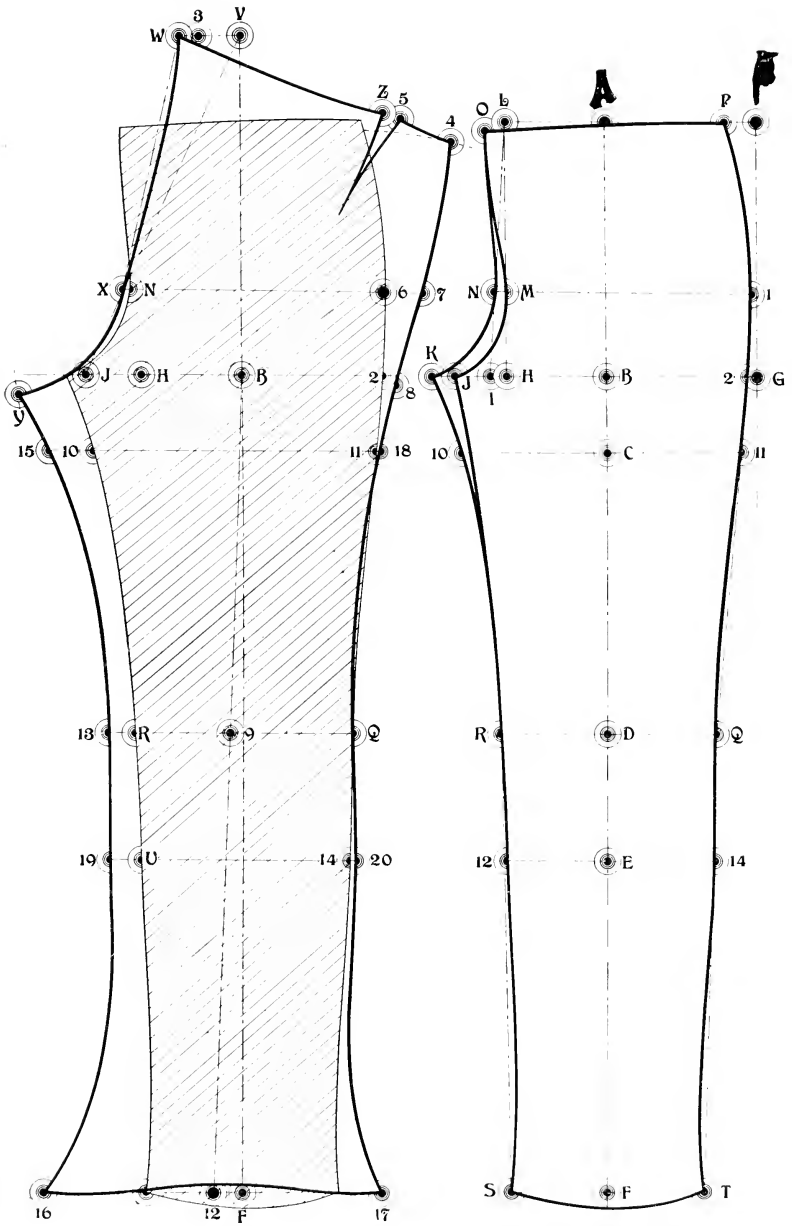

Diagram 65.

Diagram 64.



## SOME VARIATIONS IN TROUSERS CUTTING.

### Diagrams 66 and 67.

**O**N all the preceding diagrams the backseam has been drawn  $\frac{1}{12}$  and  $\frac{1}{24}$  seat backward from V as from V to W. It should be thus drawn for forms that are **flat at the seat**, and for what may be called "**walking trousers**," in contradistinction to what may be called "**sitting trousers**." For persons who sit the most of the time, or who ride, or whose vocation requires much stooping, as a laboring-man, the backseam should be drawn from V through X. So that it may be drawn either from V or as on this or the preceding diagrams, according to the shape and occupation or requirements of the wearer.

Any unusual position of the feet, as for one who **toes in**, should be noticed, as also whether the feet are carried close together, or spread apart more than is usual, and provision must be made for these variations.

It will be observed that on the preceding diagrams for trousers, the center of the backpart at the bottom is placed at point 12, which is about right for the average form. But for one **who toes inward** the center of the backpart at the bottom should be as on this diagram, directly under the center of the forepart as indicated by point U.

For one who carries the **feet close together**, when walking or standing, the position for the center of the front of the forepart should be changed as from F to 2 on Diagram 66. The peculiarities of the form for whom this trousers is designed are the wearer stands with the **feet closely together**, and he **toes in**. or perhaps more properly speaking, the toes are about as far apart as are the heels.

For a man whose feet have the usual spread, and who carries the feet closely together, the center of the forepart should be established as at U, and on the backpart the position of points 16 and 17 in their relation to S and T will be as on Diagram 61.

The measures used for the accompanying diagrams are as follows: 24 knee-length, 42 outside seam, 32 inseam, 31 waist, 38 seat,  $18\frac{1}{2}$  knee, 17 bottom. The following memorandum is entered with the measure, viz.: "**Carries feet close together and toes in.**"

Diagram 66.—**The Forepart.**

All the points excepting E, O, Q, R, S, T, U and 2 are obtained in the same manner as explained for Diagram 60.

A to O is  $\frac{1}{4}$  waist as before, and for forms with a small waist is dropped  $\frac{1}{2}$  inch below L.

F to 2 is  $\frac{1}{12}$  seat. Connect 2 and B to establish E.

E to Q and E to R are each  $\frac{1}{4}$  knee.

Deduct 3 inches from the size of the bottom and divide one-half of the remainder equally, on each side of 2 to establish S and T.

From 2 to U is  $1\frac{1}{2}$  inch, more or less, according to the size of foot and size of trousers-bottom.

Finish as represented, and cut out the pattern, making notches at G, Q and R.

#### Diagram 67.—The Backpart.

All the points, excepting W, 12, 13, 16 and 17, are obtained in the same manner as explained for Diagram 61.

V to W is  $\frac{1}{12}$  seat. The backseam may be drawn from V through X, or from any point backward from V not to exceed  $\frac{1}{12}$  and  $\frac{1}{24}$  seat according to the shape and requirements of the wearer. For forms with flat seat, and whose occupation does not demand unusual stooping or sitting, the backpart should be drafted as explained for Diagram 61 to establish W. For forms with prominent seat, or for working or sitting trousers, the backseam is shaped from V.

For the reasons stated in the foregoing, the center of the backpart, point U, is kept directly under the center of the forepart, and the width of the bottom of the backpart is divided equally on each side of U as follows:

S to U and from below U to 16 is  $\frac{1}{2}$  inch more than a full half of the bottom. Below U to 17 is the same as from below U to 16.

Q to 12 is  $\frac{1}{2}$  inch. R to 13 is  $\frac{1}{2}$  inch.

**The Fly** for this and the preceding diagrams is drafted as follows:

Lay the forepart pattern over another piece of paper and mark by it as from A to O and down to K as represented by the broken line on the small diagram superimposed on the diagram for the backpart.

K to 2 is  $1\frac{1}{2}$  inch. From 3 to 4 is 2 inches. From 4 to 5 is 2 inches. Shape the seam-edge from 2 to 3, hollowing  $\frac{1}{2}$  inch as represented. Point 5 is  $\frac{3}{4}$  inch above the broken line. The end of the strap below 5 is 1 inch wide. Shape as represented. The material is cut off on the left, or fly side, below 4.



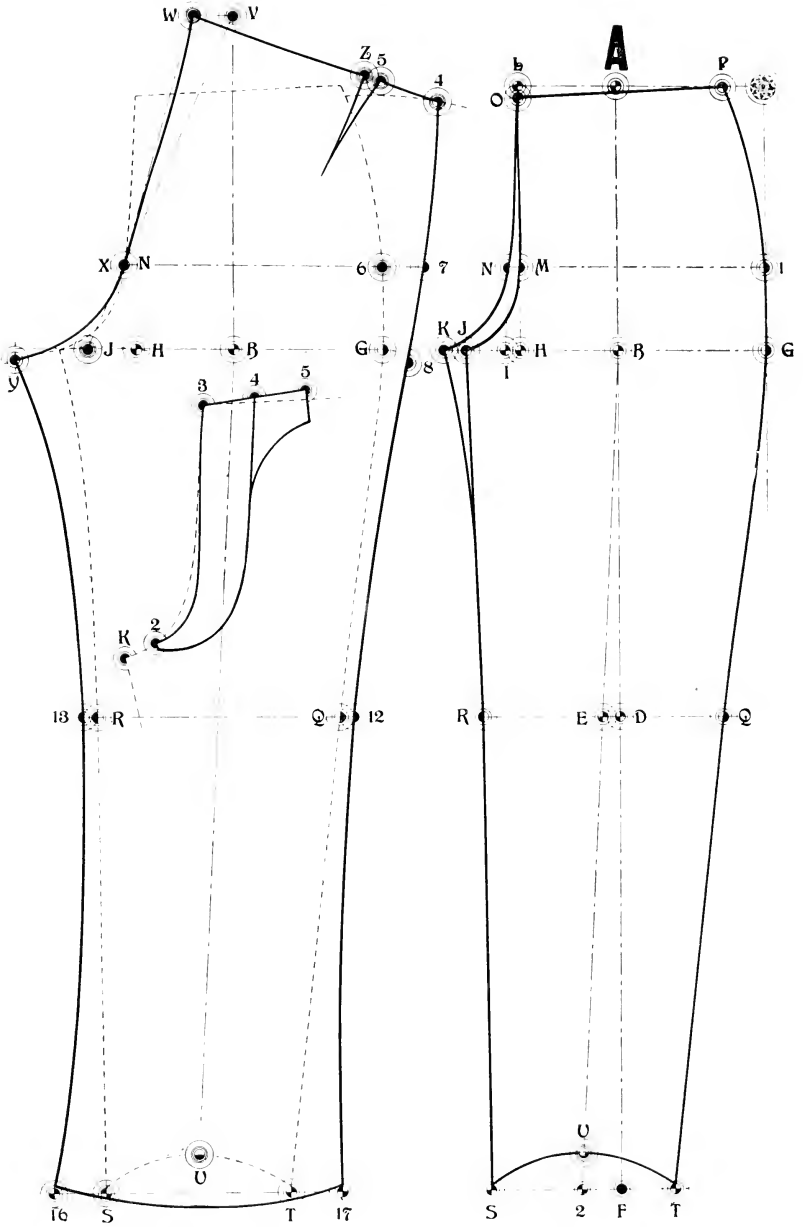

Diagram 67.

Diagram 66.

## BROADFALLS.

### Diagram 68.

**T**HE measures used for the accompanying diagram are as follows: 25 knee-length, 43 outside seam,  $45\frac{1}{2}$  front-length, 31 inseam, 52 waist, 50 seat, 23 knee, 19 bottom.

**The seat is flat** and the feet are carried with about the **usual spread at heels and toes.**

All the lettered and numbered points are obtained in the same manner as explained for Diagrams 60 and 61.

The width of a waistband is added to the backpart  $1\frac{3}{4}$  inch above 4 and  $1\frac{1}{4}$  inch above W.

Obtain the height of point O by the application of the front-length as explained by Diagram 62.

The forepart is raised 1 inch above O and P.

The shaded part represents the bearers. It is a separate piece, and includes the remaining part of the band. To produce the bearers lay the forepart pattern over another piece of paper and mark by it from P towards 1, from P to O and from O towards N. Remove the pattern.

Add the width of a waistband,  $1\frac{3}{4}$  inch above O and P and  $\frac{3}{4}$  inch forward of the line O N. The opening at the side is usually from 6 to 7 inches deep, and at the front 4 to 5 inches. Pockets are inserted in the bearers as represented by the curved line between A and 1, but may be placed at the sideseam if preferred.

The fronts of the bearers are held in place by buttons and buttonholes as represented.

For forms of this class, when the falls are not desired, the top of the forepart will be as represented by the broken line P O, and the back part by the line from 4 to W. The band should then be cut on a strong curve on the seam-edge as represented on the small diagram at the left.

From 5 to 6 is the seam-edge. From 1 to 2 is a full half of the waist. From 1 to 3 is  $1\frac{3}{4}$  inch. From 2 to 4 is  $2\frac{1}{2}$  inches. Add 1 inch outlet from 1 to 6, and  $2\frac{1}{2}$  inches turn-in from 2 to 5.

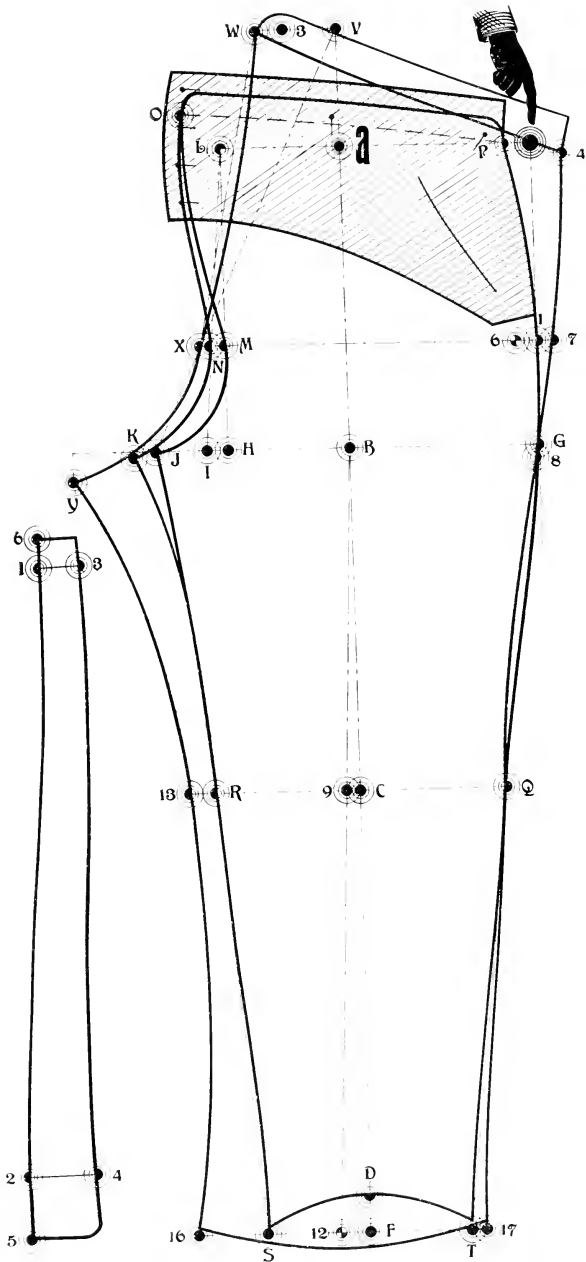

Diagram 68.

## KNEE-BREECHES.

### Diagram 69.

**T**HE measures used for the accompanying diagram are as follows: 24 knee-length, 27 length to garter,  $17\frac{1}{2}$  inseam to garter, 32 waist, 36 seat,  $14\frac{1}{2}$  knee,  $13\frac{1}{2}$  garter.

**The Forepart.**—Square forward and downward from the circled disk.

From the circled disk to G is the hip-rise. Square forward from G.

G to H is  $\frac{1}{2}$  seat. H to I is  $\frac{1}{32}$  seat. H to J is  $\frac{1}{8}$  seat. H to K is  $\frac{1}{6}$  seat.

B is half-way from G to J. Square upward and downward from B. This establishes A.

A to C is the knee-length. A to D is the length to the garter. Square upward and downward from H. This establishes L. Connect L and I.

H to M is  $\frac{1}{6}$  seat. Square forward and backward from M, C and D. This establishes N and S.

A to O is  $\frac{1}{4}$  waist. O to P is  $\frac{1}{2}$  waist. Shape from O to M and J, and from O to N and K.

R is  $\frac{3}{8}$  inch forward of the line H S. R to Q is a full half of the knee. S to T is a full half of the garter. Shape the side-scam from P through G and Q to T and the inseam from J and K through R to S as represented. Shape the bottom  $\frac{1}{2}$  inch below S and T.

Cut the forepart and make notches at G, R and Q.

**The Backpart.**—Lay the forepart pattern over another piece of paper: extend the cross-lines at the knee and bottom, and the line above A.

Pivot at S and sweep forward from K. Pivot at T and sweep backward from G and P.

B to V is  $\frac{2}{3}$  seat. Connect J and V to establish X.

H to Y is  $\frac{1}{4}$  seat. Shape from V through X to Y as represented.

V to 4 is 2 inches more than  $\frac{1}{2}$  waist, when a  $\frac{1}{2}$  inch V is required, as for a small waist. When the V is not required, as for a corpulent form, then from V to 4 is 1 inch more than  $\frac{1}{2}$  waist.

X to 6 is  $\frac{1}{2}$  seat. From 6 to 7 is 2 inches.

R to 13 and S to 16 are each  $\frac{3}{4}$  inch. Shape the inseam from Y through 13 and 16.

R to Q and 13 to 12 is 1 inch more than the knee. S to T and 16 to 17 is 1 inch more than the garter. Shape the outside seam from 4 through 7 and 12 to 17, and add a button-stand  $1\frac{1}{4}$  inch wide at the bottom as represented.

The extra length of  $\frac{1}{2}$  inch given to the forepart below S

and T is put full on the backpart from the knee to the bottom, and the fullness pressed in to form a pocket for the knee.

The tops may be finished with a separate waistband, or the band can be cut whole with the forepart and backpart, as shown on the next diagram. The fronts close with a fly.

Cut the pattern and make notches at 8, 12 and 13. Make the garter  $\frac{3}{4}$  inch wide (the finished size).

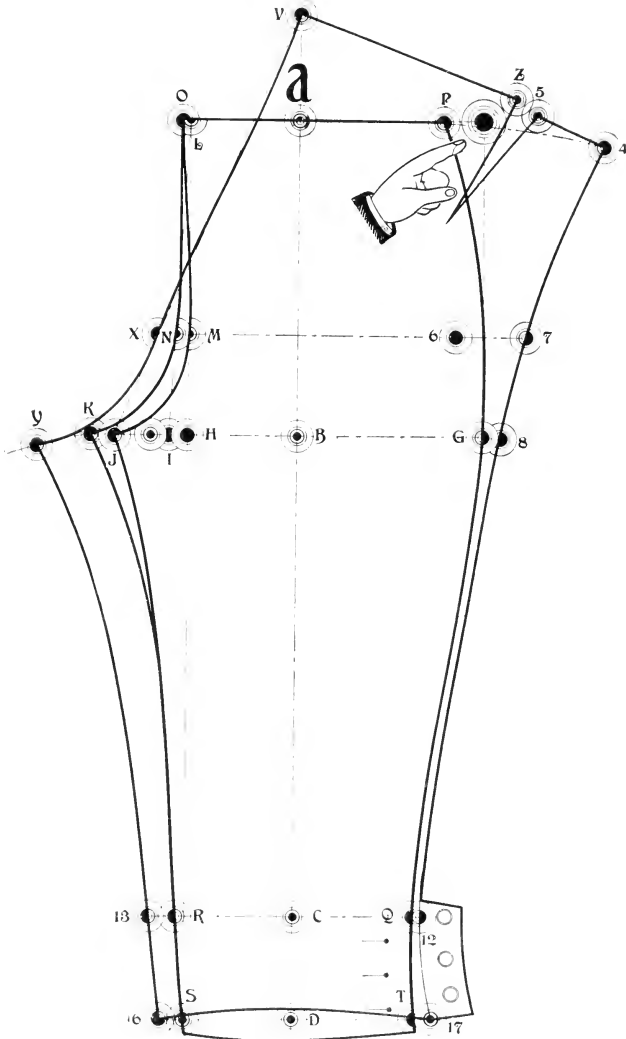

Diagram 69.

## CYCLING BREECHES.

### Diagrams 70, 71 and 72.

**T**HE measures used for the accompanying diagram are as follows: 23 length to small-of-knee, 13½ inseam, 34 waist, 38 seat, 13 small-of-knee, 14½ calf.

#### Diagram 70.—The Forepart.

Square forward and downward from the circled disk. From the circled disk to G is the hip-rise. Square forward from G.

G to H is ½ seat. H to I is 1/32 seat. H to J is ⅛ seat. H to K is 1/6 seat. Square upward from H to establish L. Connect I and L. H to M is 1/6 seat.

B is half-way from G to J. Square upward from B to establish A and extend the line downward towards D.

A to C is the length to small-of-knee. C to D is 2½ inches. Square forward and backward from M to establish N. Square forward and backward from C and D.

D to S and D to T are each a full fourth of the small-of-knee. Connect G and T to establish 1. Connect J and S to establish 2.

A to O is ¼ waist. O to P is ½ waist. From 1 to Q and from 2 to R are each ½ inch or more, according to the fullness desired. Shape between all the points as represented. The bottom is rounded ¼ inch below D. Add 2 inches above P for the waistband, or the band can be made a separate piece if desired.

The button slit between T and D is 2 inches from T, and is 2 inches long. Cut the pattern and make notches at G, Q and R.

#### Diagram 71.—The Backpart.

Lay the pattern for the forepart over another piece of paper: mark the cross-lines at the knee and bottom, and extend the line above A.

Sweep from H through K towards Y, finding a pivot near R. Sweep backward from P on the forepart and from G, pivoting at Q.

H to Y is ¼ seat. Q to 12, R to 13, S to 16 and T to 17 are each ½ inch.

B to V is 2/3 seat. V to W is 1/24 seat. Connect J and V to establish X, and shape from W through X to Y as represented. (Or, the back-seam may be shaped from V.)

W to 4 is 2 inches more than ½ waist when a ½ inch V is required to be taken out at the waist-line, and 1 inch when the V is not required.

X to 6 is ½ seat. From 6 to 7 is 2 inches or 2½ inches for quite easy breeches.

Shape between all the points as represented. The bottom is hollowed  $\frac{1}{2}$  inch between 16 and 17.

Add 2 inches above 4 and  $1\frac{1}{2}$  inch above W for the on-growing waistband, unless a separate band is desired. Cut the pattern and make notches at 8, 12 and 13.

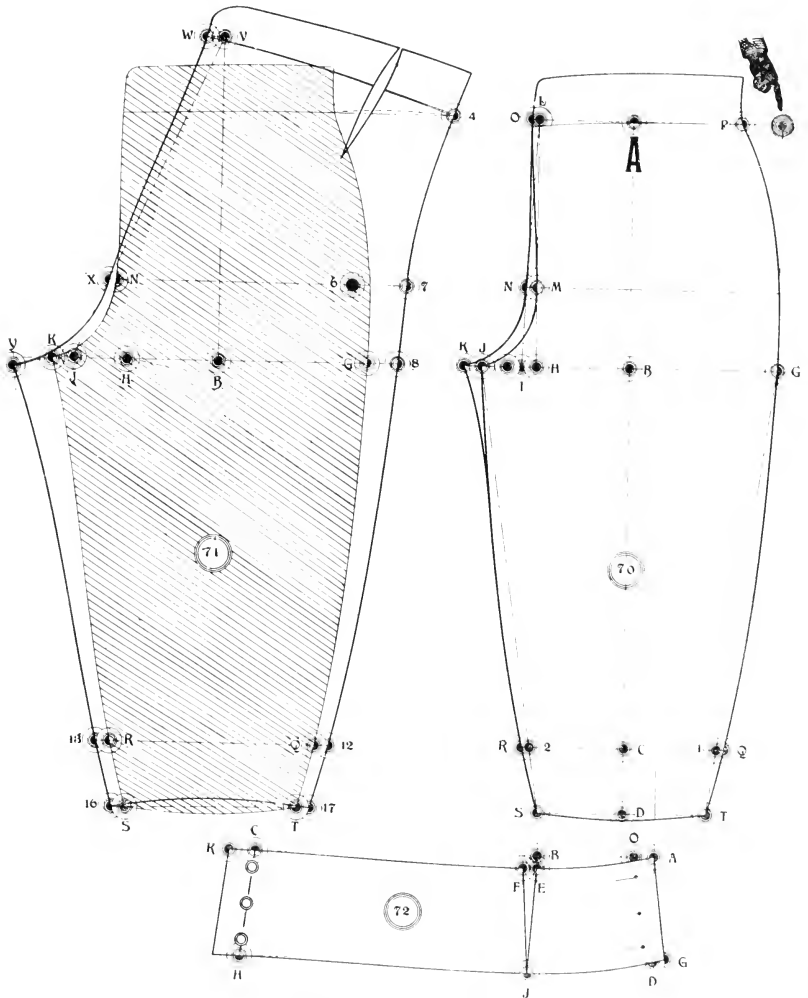

Diagrams 70, 71 and 72.

Diagram 72.—**The Continuations.**

Square downward from the slit in the forepart, and about 2 inches below square forward as from A.

Square downward from S to establish B.

A to O is  $\frac{3}{4}$  inch. O to C is  $1\frac{1}{2}$  inch more than the small-of-knee. A to D is 4 inches. D to G is  $\frac{1}{2}$  inch. B to E and E to F are each  $\frac{1}{2}$  inch.

Square forward from D. G to H is 1 inch more than the size of the calf. E to J is 4 inches. Shape as represented and add 1 inch from C to K for a button-stand.

## RIDING BREECHES.

### Diagram 73 to 79.

**T**HE breeches are usually made of whipcord. White buckskin or stockinette is sometimes used when the coat is from scarlet cloth. The continuations may be of the same material as the breeches, or of box-cloth.

The measures used for the accompanying diagrams are as follows:  $23\frac{3}{4}$  waist-to-knee-cap,  $26\frac{1}{2}$  to small-of-knee, 30 to calf, 35 to bottom,  $16\frac{1}{2}$  crotch to small-of-knee, 33 waist, 38 seat, 15 bent-knee, 13 small-of-knee,  $14\frac{1}{2}$  calf,  $11\frac{1}{4}$  bottom.

The last four measures are taken snug over the stocking. A tape may be fastened around the small-of-knee and the second and fifth measures taken to it.

#### Diagram 73.—**The Forepart.**

Square forward and downward from the horseshoe. From shoe to A is the difference between the second and fifth measures, 10 inches. Square forward from A. A to B is  $\frac{1}{2}$  seat,  $9\frac{1}{2}$  inches. B to C is  $\frac{1}{32}$  seat, about  $\frac{5}{8}$  inch. B to D is  $\frac{1}{8}$  seat,  $2\frac{3}{8}$  inches. B to E is  $\frac{1}{6}$  seat,  $3\frac{1}{8}$  inches.

F is half way between A and D. Square upward from B and F to establish G and H. Connect C and H.

G towards K is  $\frac{1}{4}$  waist,  $4\frac{1}{8}$  inches. K to J is  $\frac{1}{2}$  waist,  $8\frac{1}{4}$  inches.

B to 2 and C to 3 are each  $\frac{1}{6}$  seat,  $3\frac{1}{8}$  inches. Shape the top from J towards I, which is  $\frac{1}{2}$  inch below H.

I to K is  $\frac{3}{4}$  inch. Draw a line from K towards L parallel with I to J. K to L is 2 inches. Connect F and L. L to M is two-thirds of the distance from L to F. Square downward from F.

G to N is 1 inch more than the length from waist to knee-cap,  $24\frac{3}{4}$  inches in all.





G to P is 1 inch more than to small-of-knee,  $27\frac{1}{2}$  inches in all.

G to Q is 1 inch more than to the calf, 31 inches in all.

Square forward and backward from N, P and Q.

N to R is a full fourth of the bent-knee,  $3\frac{3}{4}$  inches. P to 5 is a full fourth of the small-of-knee,  $3\frac{1}{4}$  inches. Q to S is a full fourth of the calf,  $3\frac{5}{8}$  inches. Shape the inseam from D and E to 5 as represented.

P to Z is 1 inch. Pivot at Z and sweep upward and downward from 5. From 5 to X and 5 to Y are each  $\frac{1}{2}$  inch. Connect Z and X. Connect Z and Y. Finish the inseam from Y to S and the dart as represented.

Q to T is  $\frac{1}{12}$  seat, about  $15\frac{1}{8}$  inch. Connect A and T. This establishes U.

R to V is a half inch less than a full half of the bent-knee, 7 inches. A to W is  $\frac{1}{12}$  seat, about  $15\frac{1}{8}$  inch. Shape the outside seam from J through W, V and U to T as represented.

A small tab to finish  $13\frac{1}{4}$  inch long and 1 inch wide is added at the bottom as from T to 4. The notch at 6 is  $\frac{1}{2}$  inch above U. The notch at 7 is 4 inches above the notch at 6. R to the notch at 8 is the same as V to 7. Notch also at W. Mark for five buttonholes, the middle one opposite U and the others 1 inch apart. There is also a buttonhole in the tab.

#### Diagram 74.—The Backpart.

Lay the forepart pattern over another piece of paper and extend the lines past R and S.

Draw lines 1 inch above V towards 22, parallel with the line V R; 1 inch above U towards 21, parallel with the line U 5, and 1 inch above T towards 20, parallel with the line T S.

Pivot at 5 and sweep outward from E. Pivot at W and sweep outward from J.

E to 12 is  $\frac{1}{2}$  inch more than  $\frac{1}{12}$  seat,  $2\frac{1}{8}$  inches. Shape the inseam from 12 towards 5 as represented.

From 5 to 15 is  $1\frac{1}{2}$  inch. Establish O opposite and  $1\frac{1}{2}$  inch from U. Pivot at O and sweep downward from 15.

From 15 to 17 is 1 inch. Shape the dart from O to 15 and to 17.

Extend the line below 17 parallel with the inseam above 15. From 17 to 18 is 1 inch. Finish the inseam from 18 to 19 parallel with the forepart.

S to T and 19 to 20 is 1 inch more than the calf,  $15\frac{1}{2}$  inches in all.

From 5 to U and 5 to 21 is 1 inch more than the small-of-knee, 14 inches in all.

R to V and 16 to 22 is 1 inch more than the bent-knee, 16

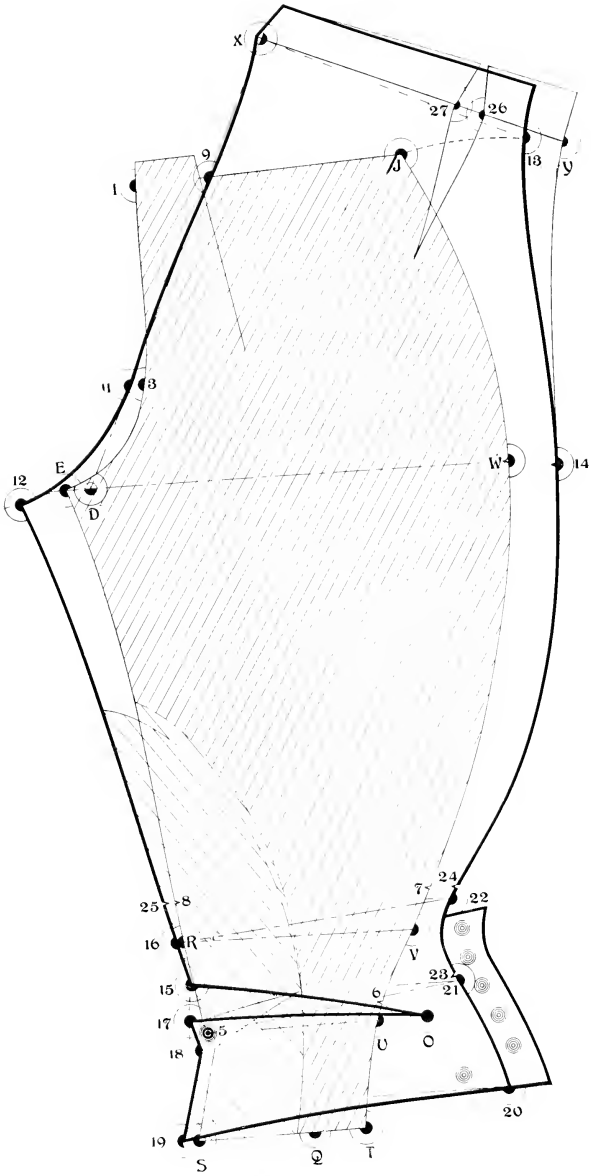

Diagram 74.

inches in all. W to **14** is  $\frac{1}{12}$  seat, about  $1\frac{5}{8}$  inch. Shape from **14** through **22** and **21** to **20**, and add  $1\frac{1}{2}$  inch for a button-stand as represented. Shape the bottom from **19** to **20**.

I to **9** is  $\frac{1}{8}$  seat,  $2\frac{3}{8}$  inches. Draw a straight line from D through **9**. From **9** to X is  $\frac{1}{4}$  seat,  $4\frac{3}{8}$  inches. Point **11** is directly opposite **3**. Shape the backseam from  $\frac{1}{4}$  inch backward of X through **9** and **11** to **12** as represented.

From X to **13** is 1 inch more than  $\frac{1}{2}$  waist,  $9\frac{1}{4}$  inches.

From **20** to the notch at **23** is the same as from T to the notch on the forepart at **6**. The notches at **24** and **25** are opposite those at **7** and **8**.

Measure the forepart between the notches at **7** and W, and make from **24** to **14** the same. Also measure from W to J and make from **14** to **13** the same. Q is the same as on Diagram 73.

Add  $1\frac{3}{4}$  inch above **13** and  $1\frac{1}{4}$  inch above X for the waist band and finish as represented.

When a dart is required, as for a small waist, X to Y is 2 inches more than  $\frac{1}{2}$  waist. Take out a  $\frac{1}{2}$  inch dart as from **26** to **27**.

The reinforcements, made of buckskin, extend  $\frac{2}{3}$  the length of the leg above S.

Diagram 75.—**The Continuations on the Forepart.**

Square the lines T S and T **1**. Points T, Q and S are the same as the corresponding points on Diagram 73. Square downward from S.

**1** to T and **2** to S are each the same as the difference between the length to the calf and bottom, 5 inches.

J from **1** is  $\frac{5}{8}$  inch. Shape from T to J and  $\frac{1}{2}$  inch above the line T S as represented.

Diagram 76.—**The Continuations on the Backpart.**

Square the lines **2** to **3** and **2** to **6**. **20** from **2** is  $\frac{1}{4}$  inch. **19** from **20** is the same as between the corresponding points on the backpart. (Diagram 74.)

**3** from **19** is  $\frac{1}{4}$  inch. **1** from **19** is the same as **19** to Q. (Diagram 74.) Square downward from **1** and **3**.

**6** from **2**, **5** from **1** and **4** from **3** are each the same as T to **1**. (Diagram 75.)

The size around the bottom is  $11\frac{1}{4}$  inches. To this must be added  $1\frac{1}{2}$  inch for six seams. This gives  $12\frac{3}{4}$  inches. By measuring from **2** to J (Diagram 75) and **4** to **6** (Diagram 76) we find that it measures  $17\frac{1}{8}$  inches, or  $4\frac{3}{8}$  too much. This is disposed of by taking out  $\frac{1}{5}$  of it ( $\frac{7}{8}$  inch) from **2** to K (Diagram 75), and the same amount from **4** to E, M to **5**, **5** to N and

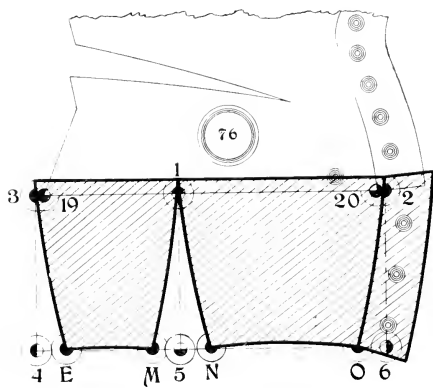
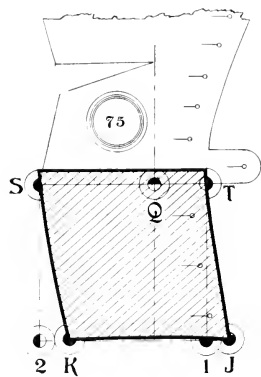

Diagrams 75 and 76

6 to O on this diagram. The top is shaped  $\frac{1}{2}$  inch above the line from 2 to 3. Add  $1\frac{1}{2}$  inch for a button-stand and finish as represented.

Diagram 77.—On this diagram the upper part of Diagram 73 is shown with the fall turned down. To form the bearer, which is shaded, proceed as follows:

From the front of the fall to A is  $3\frac{1}{4}$  inch. A to B is  $2\frac{1}{2}$  inches. M is the same as on Diagram 73. Shape the bearer from A to B and B to M as represented.

The band is cut  $2\frac{1}{4}$  inches wide, extending from the side-seam to the front of the bearer. It may be cut whole with the forepart from the side-seam to the inside seam of the bearer if desired. In which case that part of the band which is forward of the line above M is cut whole with the bearer, the seam above M extending to the top of the band.

Diagram 78.—Here is shown the position of the fall when in place. It is finished with a welt  $1\frac{1}{4}$  inch wide, which is sewed to the inseam of the fall, stitched all around and tacked at and across its pointed end. The fall and bearer are held in place by buttons and buttonholes as represented.

Diagram 79.—The breeches may be cut without the darts at the small-of-knee, if preferred, as shown on this diagram.

Points N, P, Q, R, 5, S, T, U, V and the notches at 6 and 7 are obtained in the same manner as explained for Diagram 73. The inseam is shaped to 5, and the dart is omitted. The notch at 9 is  $\frac{1}{2}$  inch above 5. The notch at 8 is 4 inches above 9.

To draft the backpart, draw straight lines 1 inch above and parallel with line V R, U 5 and T S. Shape the inseam towards 5. This establishes 18.

Extend the line below 18 to 19 parallel with line 5 to S.

S to T and 19 to 20 is 1 inch more than the calf.

From 5 to U and 18 to 21 is 1 inch more than the small-of-knee.

R to V and 16 to 22 is 1 inch more than the bent-knee.

The notch at 10 is  $\frac{1}{2}$  inch above 18. The notch at 25 is opposite 8.

From 20 to the notch at 23 is the same as from T to 6. From 23 to 24 is 1 inch less than 6 to 7.

The fullness of 1 inch on the forepart between the notches 6, 7, 8 and 9 is put on full to the backpart between the corresponding notches.

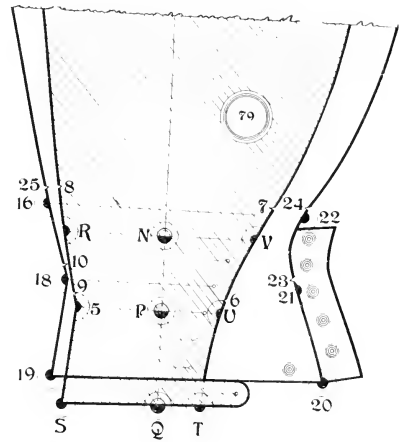
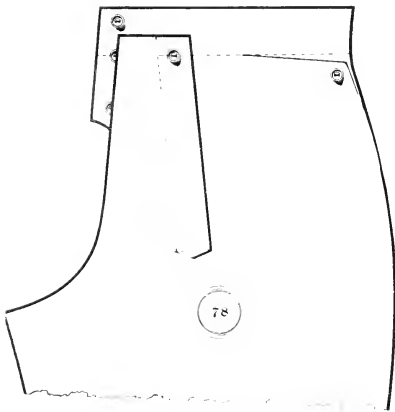
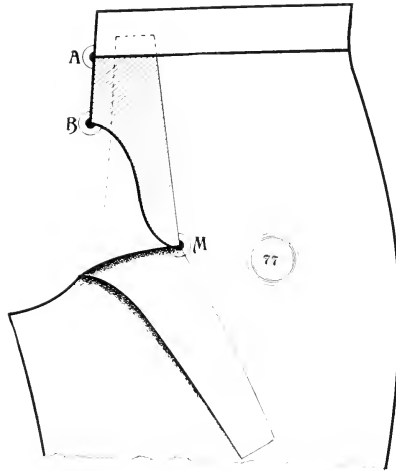

Diagrams 77, 78 and 79.

## SINGLE-BREASTED SACK COAT.

### Diagram 80.

**T**HE measures used for the accompanying diagram are as found on the table for a form of 36 breast. It is a highly artistic novelty and commands the admiration of the observer by its pleasing lines and graceful proportions. For a man 5 feet and 8 inches in height the length is 31 inches. The side seams begin well under the arms, and curved slightly to the waist. From there they run straight to the bottom. They are vented to the seat-line and the bottom corners are slightly rounded. It is nearly close-fitting at the back-waist and has a distinct flare about the hips. The bottom has a pronounced dip towards the front.

### To Draft.

Square forward and downward from A.

All the points on and above the breast-line, and all those on the waist-line, excepting F, T, 9, 10, and 11, are obtained in the same manner as explained for Diagram 25.

The end of the roll and points 23, 24, 25 and the collar are established according to style, as explained for Diagram 26.

C to F is  $\frac{3}{4}$  inch. 6 from 29 is  $\frac{1}{2}$  inch less than  $\frac{1}{4}$  breast. Draw a straight line from Z to 6. This gives T on the waist-line. Square downward from T to establish 8.

The back-waist surplus (T to U) is  $2\frac{3}{4}$  inches for this draft. About one-half of this is taken out as from T to 9, say  $1\frac{1}{2}$  inch, and  $\frac{5}{8}$  inch between 10 and 11. The total amount taken out between T, 9, 10 and 11 is about  $\frac{3}{4}$  of the quantity between T and U.

9 from T is then  $1\frac{1}{2}$  inch. 10 from 9 is  $\frac{1}{6}$  waist. N is half-way between J and M. Draw a straight line from N through 10. This gives 26.

11 from 10 is  $\frac{5}{8}$  inch as above explained. 27 from 26 is  $\frac{1}{2}$  inch. Shape from N through 11 and 27 as represented.

12 from 7 is  $3\frac{1}{2}$  inches plus the quantity between 8 and 20,  $4\frac{1}{2}$  inches in all for this draft. Draw a guide-line from 9 through 12 and shape from 5 through 9 and 12 as represented.

31 from 30 is  $1\frac{1}{2}$  inch. 28 from 5 is the same as 6 from 5.

Square downward from 3 and establish 32 half-way between the waist and seat-lines.

18 from 11 is the same as 35 from 10. Shape between all the remaining points as represented.





## FANCY CUTAWAY.

### Diagram 81.

**A** COAT that combines pleasing lines and some novel features. At the back-waist it is shaped to the form and there is an entire absence of a seam across the waist. For a form of average height the lengths are  $18\frac{1}{2}$  to fashionable-waist and 37 full length. The remaining style features are clearly shown on the diagram.

### To Draft.

Square the lines A 19 and A E.

All the points not herein explained are obtained in the same manner as explained for Diagram 25, excepting style points 21, 22, 23, 24, 25 and the end of the roll, which are established according to style.

The run of the shoulder seam is obtained by drawing a straight line from H midway between P and Q. This gives 20. Connect 20 and 1 to establish 5.

Connect 5 and O to establish 18.

6 from O is  $\frac{1}{4}$  inch more than  $\frac{1}{8}$  breast. 7 from E is  $\frac{1}{4}$  inch more than O to 6. Shape from 5 through 18 to 6. This gives T. Shape from 6 to 7 rounding forward of a straight line  $\frac{1}{4}$  inch as represented.

F to T and S to U is the back-waist. Square downward from U to establish 11.

8 from T is two-thirds of the quantity between T and U. 12 from 11 is 3 inches when the seat is 5 inches larger than the waist,  $\frac{1}{4}$  inch less than 3 inches for each inch that the difference between the waist and seat is less than 5 inches, and  $\frac{1}{4}$  inch more than 3 inches for each inch that the difference is more than 5 inches. Draw a straight guide-line from 8 through 12 and shape from  $\frac{1}{4}$  inch forward of 5 through 18, 8 and 12 to 28, which is about 1 inch forward of the guide-line at the bottom.

Sweep from T pivoting at 18 to establish 26, and make 28 from 26 the same as 7 from T.

The shape of the front below 3 is wholly a matter of style. For this diagram 30 from 29 is  $\frac{1}{3}$  breast. 31 from 30 is 2 inches.

9 from 8 is  $\frac{1}{4}$  breast. 10 from 9 is the same as U to 8.

N is half-way from J to M. Draw a straight line from N midway between 9 and 10. This establishes the back-end of the pocket opening.

Pivot at 19 and sweep forward from the back-end of the

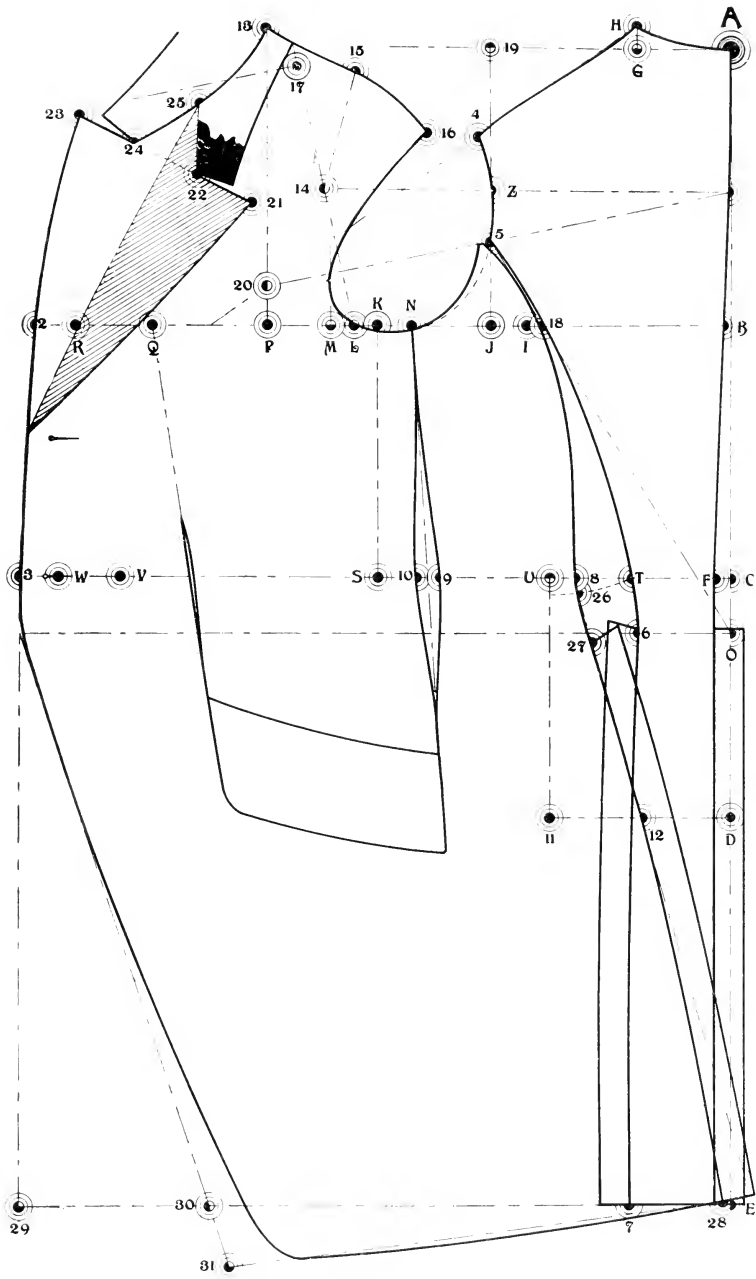

Diagram 81.

(171)

pocket. The front of the pocket is established  $\frac{1}{2}$  waist forward of the back-end.

The flap is  $3\frac{1}{2}$  inches wide. Connect the front of the pocket and Q, and finish as represented.

## OPERA COAT.

### Diagram 82.

**T**HE measures used are 40 breast taken over the undercoat, and 44 length.

Square forward and downward from the Star.

Star to A is  $\frac{2}{3}$  breast. A to B is  $\frac{1}{4}$  inch less than  $\frac{1}{16}$  breast.

B to C is  $\frac{1}{4}$  breast. A to D is  $\frac{1}{4}$  inch more than  $\frac{1}{2}$  breast. A to E is the length. Pivot at the Star and sweep from B, C, D and E. This gives F.

F to J is  $5\frac{5}{8}$  inch more than  $\frac{1}{6}$  breast. Draw a straight line from Star through J. This gives G, H and N.

K is half-way from G to H. Square out from K.

K to L and N to O are each 2 inches. K to M is  $\frac{3}{4}$  inch.

P is half-way from D to J. Connect Star and P. This gives T and U.

Q is half-way from D to P. Connect Star and Q. This gives S.

R is half-way from P to J. Connect Star and R. This gives W.

V is half-way from U to P. Connect S and V. This gives I.

Connect W and U. W to 3 is the same as S to I.

Q to Z is  $\frac{1}{8}$  breast. Draw a straight line from T through Z. This gives 2.

R to Y is  $\frac{1}{2}$  inch less than  $\frac{1}{8}$  breast. T to X is  $\frac{1}{12}$  breast. Draw a straight line from X through Y. This gives 1. E to 4 is 2 inches.

Shape between all the points as represented. The shoulder seam is rounded out  $\frac{1}{2}$  inch from the straight line from 3 to W. The opening for the hand is  $3\frac{1}{2}$  inches below Y and is 12 inches long.

The Collar—Square upward and forward from 4.

6 from 4 is the size of the neck. (A to S and W to M.) 5 is half-way from 4 to 6. Square upward from 5 and 6. 7 from 4 is  $2\frac{1}{2}$  inches. 8 from 5 and 9 from 6 are each 2 inches. 11 from 8 is 1 inch. 10 from 7, 12 from 11 and 13 from 9 are each  $3\frac{1}{2}$  inches. The stand is shaped  $\frac{1}{4}$  inch backward of 4,  $\frac{1}{4}$  inch below 5, and 2 inches forward of 6 and 9. The leaf is shaped  $\frac{1}{2}$  inch backward of 10, and  $\frac{1}{2}$  inch forward of 13.

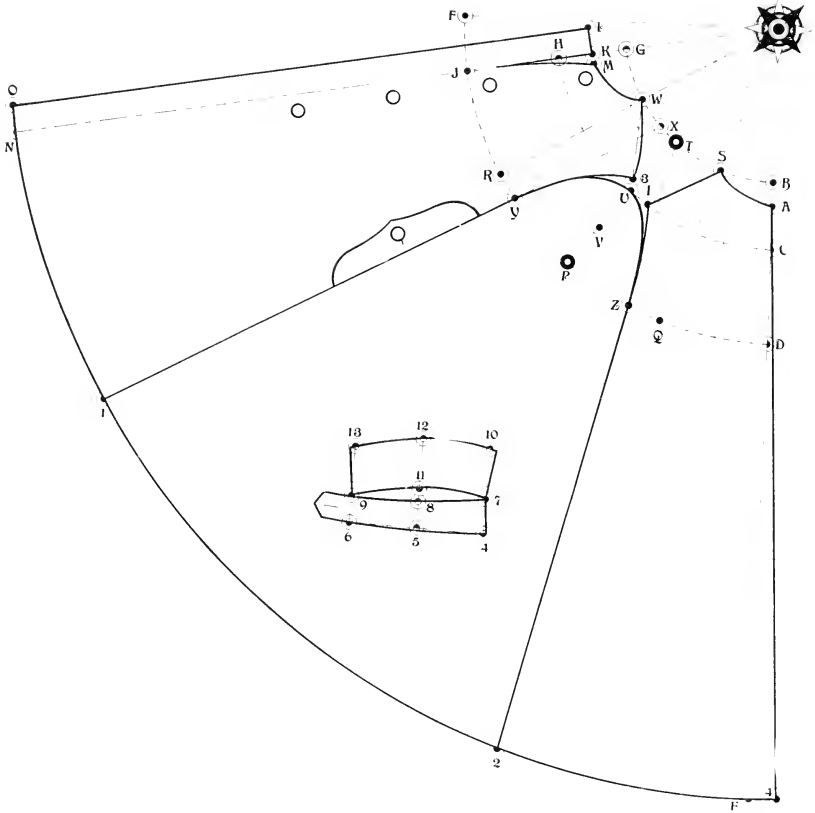

Diagram 82.

## THE IMPORTANCE OF RIGHT MEASURES.

**T**HE best way to avoid most of the alterations which usually obtain is **to start right.**

The first thing to be done is to ascertain the requirements of the form to be fitted **by a direct and right measurement** of the form and its several parts. When this is done on right principles, intelligently, and with approximate correctness, there will be but few alterations so far as the fitting qualities are concerned for which the cutter is justly blameable.

It is quite natural for the inexperienced cutter to think that every wrinkle is due to some mistake on his part. Perhaps they are. The more experienced and skilful, however, will not grant this as readily. **He will find the cause** of the trouble. He will trace it, if not at once apparent, perhaps to a fault on his part, and perhaps to some other source.

How can a cutter keep on good terms with himself who finds that, as a rule, he must pull his work apart, take off here, let out there, and perhaps have to make another garment entirely? There is no necessity for such inefficiency, and it ought not to be tolerated.

No progressive cutter will be content until the alterations at the try-on, inasmuch at least as they relate to **fitting qualities**, are reduced to the minimum. The purpose of a try-on should be to detect any possible error in fit or style, rather than to depend primarily on it **as the only way** by which he can secure either.

Profuse instruction as to alterations would not be as imperative as heretofore if the work is **started right.** Methods and principles that are just right for the wholesale trade, and that are also of great value to the custom-cutter, are alone **inadequate for the needs of the custom-cutter.** Methods for drafting by proportions alone, aided by the try-on, when intelligently used, will secure a fairly good average in results, but the average will be a considerable below 100 per cent. The custom-cutter is expected to do much more than the wholesaler. He must employ methods that are adequate to meet the requirements of 100 per cent of his customers.

To accomplish this he must, as a primary necessity, "**know how to measure.**"

The necessity for measures is due to the fact that forms vary greatly in development. If these variations are not ascertained at the start, they will have to be conformed to at the try-on. The result is expense, and more or less unnecessary bother.

It matters not to the cutter who knows what are the proper measures, and knows how to take them, what the shape may be.

He can determine in advance much important data, and escape very many pitfalls in which his less qualified brother is often entangled. The changes at the try-on are minimized, and very many are rendered unnecessary.

There are those who condemn measures as "**mechanical and unreliable.**" They are, to be sure, when wrongly taken or applied. But there is no order of genius that can produce a perfect pattern unaided by the mechanical appliance known as the tape-measure unless the form is a **proportionate** one. The addition of a column of figures is misleading **when it is not rightly added.** Yet we do not condemn mathematics.

To some it may be considered of little moment **how** a garment is fitted, so long as it is properly fitted, whether by one means or another. I do not so consider the matter. There are conditions under which it is not possible to try-on a garment. The one that can arrive at the end desired, not depending primarily on a try-on and more or less of alterations, is unquestionably the most skilful and the most valuable.

The student, therefore, who desires some day to rank among the "top-notchers" **must practice measuring.** Study carefully and follow closely the instructions given in regard to measuring. Practice measuring repeatedly, taking a number of convenient subjects until you find that a measure taken yesterday is practically the same as one taken to-day. Practice alone will give all essential accuracy required, also speed and absence of all awkwardness and manners of the novice.

Should you find that the few first garments run a little large or a little small as a whole or in any part, take the measures a little closer or a little easier as the case may be. Suppose that you find coats are full at the blades. Then take the blade-measure a little closer than formerly.

**You must know when a garment is properly constructed,** or have someone about you who does know, and upon whom you can rely until you also have that knowledge. **A tight lining, a short lining, a crooked canvas, seams unevenly joined, sleeves unbalanced, neck-gorges stretched or unduly contracted,** and many other things are matters which must be looked after. Many a garment has been killed at the try-on because of a lack of experience on the part of the cutter. He does not know the cause of the trouble, and does perhaps the very thing he should not have done. That is to say, he has directed that the coat be taken in under the arm, the scye advanced, and something taken off at the shoulder seam. These changes have only made a bad matter worse. The two first changes mentioned gave more crookedness to the shoulder and reduced the breast size. The other change has apparently made it necessary to sink the scye, as the tight-

ness complained of by the wearer has not disappeared. What was required was, that **the lining should have been let out** across the coat from the shoulder to the waist or bottom. The narrow and short lining contracted the garment, caused the outside apparent fullness and the tightness complained of by the wearer. **Beware of tight linings. Beware of short linings.**

It is quite likely that in your early experience there will be faults for which you are directly responsible. Blades may be full, and there may be wrinkles at the scye and through the shoulders, and yet there be no lack of lining and no crooked canvas. Again I counsel, endeavor to learn the cause of the difficulty. Then apply the remedy where it is required, and do not make the same mistake again. If you are only ambitious to get out of the particular hole in which you find yourself so that you can get the job off your hands, without tracing your blunder to its cause, whether in yourself or in someone else, you will continue to blunder and stumble all the way along.

We shall always be deeply interested in your future career and invite correspondence on any matter in which we can further serve you, in any way, and at any time.





APR 8 1910

One copy del. to Cat. Div.

1000 1000

LIBRARY OF CONGRESS



0 014 082 749 6

