

SCIENTIFIC AMERICAN

A WEEKLY JOURNAL OF PRACTICAL INFORMATION, ART, SCIENCE, MECHANICS, CHEMISTRY, AND MANUFACTURES.

Vol. XXXVIII, No. 16.
[NEW SERIES.]

NEW YORK, APRIL 20, 1878.

[\$3.20 per Annum.
[POSTAGE PREPAID.]

Report of the Director of the Central Park Museum, 1878.

This report, recently issued, shows that during the past year there were added to the collection, through donations, purchases, deposits, exchanges, and births in the menagerie, 147 mammals, 169 birds, and 8 reptiles. The total number of animals exhibited during the year was 942. Most noteworthy of the animals that came into possession of the menagerie may be mentioned a fine pair of guanacos, received in exchange for a lion bred in the park. Among the animals placed on deposit that deserve particular remark are three polar bears (no specimens of which have been exhibited since 1875) and one pair of brown hyenas, the first ever brought to this country. During the latter part of the year, 8 Indian and 5 African elephants (the latter quite young and ranging from 40 to 60 inches in height) were exhibited, and attracted great attention.

Of the 107 animals born in the menagerie during the year, the most notable was that of a monkey, since it is very rarely the case that these animals breed in confinement. Losses by death have been few, and at the close of the year there were 706 animals on hand, valued at \$71,966; of this amount, \$13,371 was the property of the department, and \$58,591 that of exhibitors.

The greatest economy has been practised in the management, and, as compared with the expenses of the preceding year, a reduction of \$4,081.79 has been effected. In an ap-

pendix to the report, the Director gives a classified list of the animals in the menagerie, with both their scientific and common names, and also a catalogue of the books and periodicals which he has thus far collected as a nucleus for a library.

A SAILING RAILWAY CAR.

"The Force of Wind in the Motion of Sails may be applied also to the driving of a Chariot, by which a Man may sail on the Land, as well as by a Ship on the Water," remarks Bishop Wilkins, in the second book of his "Mathematical Magick," printed at London in 1648. Such chariots, he goes on to explain, have been used from time immemorial on the plains of China and also in Spain, but their most remarkable success has, says the learned author, been achieved in Holland, where "it did far exceed the Speed of any Ship, though we should suppose it to be carried in the open Sea with never so prosperous Wind: And that in some few Hours space it would convey Six or Ten Persons, 20 or 30 German miles, and all this with very little labour of him that sitteth at the Stern, who may easily guide the Course of it as he pleaseth."

The astonishment of the good Bishop and his cotemporaries at the speed attained may well be realized when it appears that Dutch sailing carriages, constructed as shown in Fig. 2, next page, accomplished a distance of 42 miles in two hours. This was an unheard of speed in those days for any means of locomotion. "Men ran before it seeming to

go backwards. Things which seem at a great distance being presently overtaken and left behind." Until railroads were invented, without doubt the wind carriage outstripped all other means of traveling; and it is perhaps a little anomalous that more efforts were not made toward its improvement. Bishop Wilkins himself made an effort in that direction by rigging a wind mill in the vehicle, whereby "the Sails are so contrived, that the Wind from any Coast will have a Force upon them to turn them about," and he proposed to gear this contrivance with his wheels, and "consequently carry on the chariot itself to any Place (though fully against the Wind) whither it shall be directed." This same thing was reinvented a couple of years ago, in this country, as we noted at the time, and perhaps it might be uncharitably inferred that if, after the labor of two and a quarter centuries, our inventors could do no better than reproduce the venerable Bishop's notion, the *ultima Thule* of originality in wind carriages must be close at hand. Yet in reality the ice boat is probably the offspring of the wind-impelled land vehicle; and the little carriages to be drawn along by huge kites, such as many an ingenious school boy has constructed, are allied to it.

It is curious to note, however, that while to the railroad is owing the abandonment of the wind carriage, to the same agency it now seems likely that its rejuvenation will be due. Wind vehicles are already in use on the long stretches of tracks which extend over the Western prairies, and the

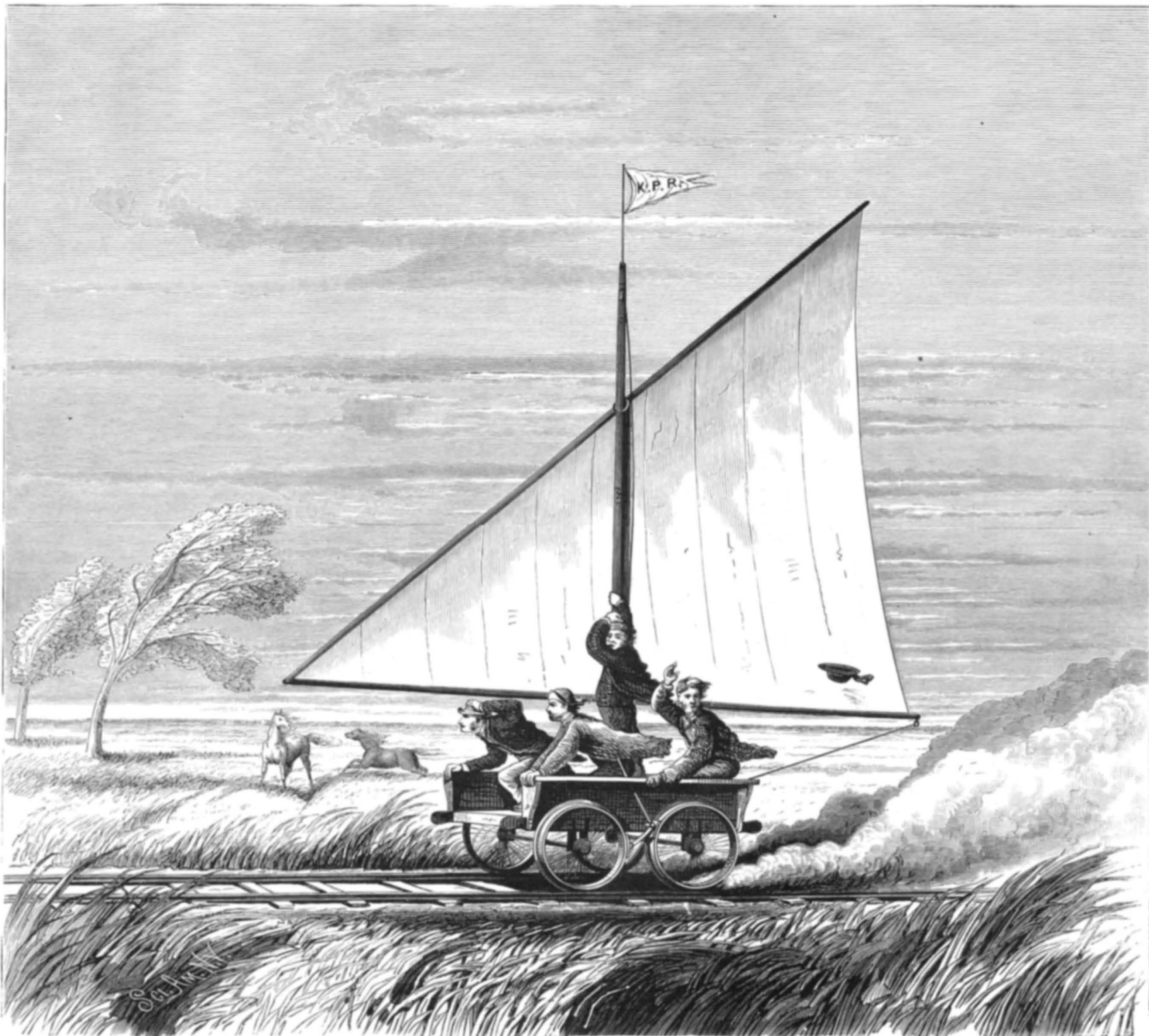

Fig 1.—SAILING CAR ON THE KANSAS PACIFIC RAILROAD.

speed attained is said to rival that of the fast express train. We are indebted to Mr. L. O. Wood, of Hays City, Kansas, for the photograph from which our engraving of a sailing car, devised by Mr. C. J. Bascom, of the Kansas Pacific Railroad, is prepared.

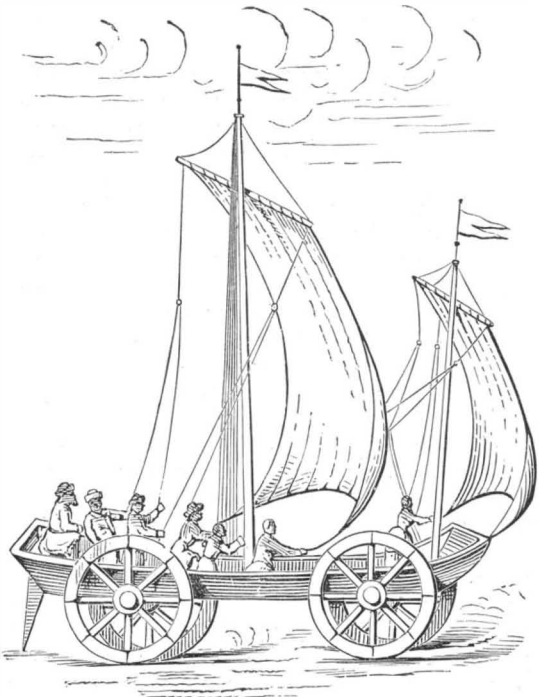

Fig. 2.—SAILING CHARIOT.

The vehicle has four wheels, each 30 inches in diameter, is 6 feet in length, and weighs 600 lbs. The sail has two booms, respectively 14 and 15 feet in length, and an area of about 81 square feet. The mast is 11 feet high, tapering from 4 inches square at the heel to two inches at the truck.

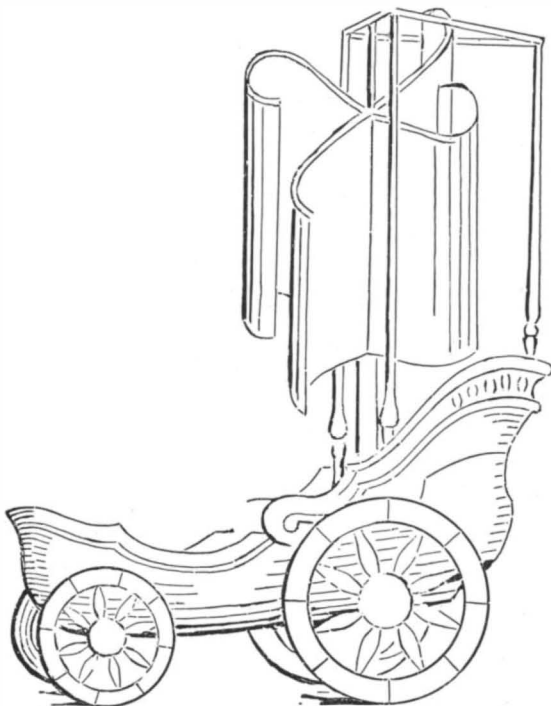

Fig. 3.—BISHOP WILKINS' CHARIOT.

Mr. Bascom informs us that his car has been in active operation on the Kansas Pacific Railway for the past three years, being employed to convey repairing parties to pumps, telegraph lines, etc., along the route.

HERR F. SIEMENS, of Dresden, has succeeded, it is said, in remedying the tendency of hardened glass to shatter itself without any apparent reason.

Scientific American.

ESTABLISHED 1845.

MUNN & CO., Editors and Proprietors.

PUBLISHED WEEKLY AT NO. 37 PARK ROW, NEW YORK.

O. D. MUNN. A. E. BEACH.

TERMS FOR THE SCIENTIFIC AMERICAN.

One copy, one year, postage included. \$3 20 One copy, six months, postage included 1 60

Clubs.—One extra copy of THE SCIENTIFIC AMERICAN will be supplied gratis for every club of five subscribers at \$3.20 each; additional copies at same proportionate rate. Postage prepaid.

The Scientific American Supplement

is a distinct paper from the SCIENTIFIC AMERICAN. THE SUPPLEMENT is issued weekly; every number contains 16 octavo pages, with handsome cover, uniform in size with SCIENTIFIC AMERICAN. Terms of subscription for SUPPLEMENT, \$5.00 a year, postage paid, to subscribers. Single copies 10 cents. Sold by all news dealers throughout the country.

Combined Rates.—The SCIENTIFIC AMERICAN and SUPPLEMENT will be sent for one year, postage free, on receipt of seven dollars. Both papers to one address or different addresses, as desired.

The safest way to remit is by draft, postal order, or registered letter. Address MUNN & CO., 37 Park Row, N. Y.

Subscriptions received and single copies of either paper sold by all the news agents.

VOL. XXXVIII, No. 16. [NEW SERIES.] Thirty-third Year.

NEW YORK, SATURDAY, APRIL 20, 1878.

Contents.

(Illustrated articles are marked with an asterisk.)

Table listing various articles such as Aconagua peak, Astronomical, Business and personal, Cement, aquarium, etc., with corresponding page numbers.

TABLE OF CONTENTS OF THE SCIENTIFIC AMERICAN SUPPLEMENT No. 120, For the Week ending April 20, 1878.

Detailed table of contents for the supplement, including sections on Engineering and Mechanics, Technology, Chemistry and Metallurgy, Electricity, Light, Heat, etc., and Astronomy.

EVERY MAN HIS OWN KEELY MOTOR.

John Aylwin Bevan, M.D., has settled it. Now it is perfectly clear what it is that makes people die so soon. It is clear, too, that it is quite unnecessary for the human machine to run down, so to speak, so much before its time.

Scientific physiologists pretend to tell how our life forces and activity are kept up by the transformation of food within the system. So much food, in such and such complex chemical combinations, reduced to such and such lower combinations, evolves so much force to carry on the work of living.

Dr. Bevan has discovered a new physiological force, which he calls thermo-motor force. He has discovered also that this newly discovered force resides in the medulla oblongata, making it a sort of physiological Keely motor.

The importance of Dr. Bevan's discoveries, as indicated by the space it gets in newspaper reports, justifies an extended statement of them here. It appears that "the medulla has a certain quantity (amount not stated) of stored-up thermo-motor force in a state of rest, which once expended in motion can never be restored."

"In what way?" does the reader ask? By eating cereals and refraining from a flesh diet, Dr. Bevan replies. The red-blood cells carry oxygen to every part of the body and release it in the capillaries, where it performs its functions of decomposing the tissues and brain and releasing thermo-motor force.

This philosophy is impregnable. It is as if Mr. Keely should say: "Here, gentlemen, is a pint of water in my machine. Stored up in it is forty million horse power, more or less. Every time you agitate the machine force is evolved, and of course the less you agitate it the longer your power will last.

We fear, however, that Dr. Bevan is not prudent. Some parts of his last lecture read as though he had recklessly indulged in a mutton chop or some other blood heating compound. Witness the following: "By the help of the discovery of the thermo-motor force man will become his own savior, for he will now need no physician to teach him self-control.

ciple based on love of self, will overturn the rival schools of medicine by rendering them superfluous, and priest armed with threats of eternal woe and physician with bolus and globule will be consigned, along with the rack and the thumb screw, to the wonted oblivion of the dark ages, and in their stead will rise up, under the shelter of friendly colleges, men who will consecrate their lives to the discovery and promulgation of these great truths upon which man's physical and mental welfare depend." Modesty has always been a characteristic of great discoverers!

HOW FAST CAN YOU THINK?

"Quick as thought" and "Quick as lightning" are commonly used as synonymous expressions. But their difference is really great. An electric impulse traverses a wire as a wave of motion; a nervous impulse proceeds by a development of chemical change in the nerve. It runs along the nerve somewhat as combustion follows a train of gunpowder, and not much if any more rapidly. Indeed Helmholtz has clearly determined the rate of nervous propagation to be less than a hundred feet a second, or about a mile a minute. To use a rude illustration, if a railway could feel, the sense report of a train starting in New York would reach Albany but little in advance of the fastest trains that have been run upon the Hudson River Road. Even along courses as short as the nerves of the human body an appreciable time is required for the passage of nervous impulses.

With a simple apparatus, Hirsch found that a touch upon the face could be recognized and responded to by a predetermined signal operated by the hand, in one seventh of a second. With a sound test, acting, of course, upon the ear, the answering signal was made in one sixth of a second; when the eye was addressed, the response came in one fifth of a second. Since the distances traveled by the nervous impulses were very nearly the same in all these experiments, it is evident that the greater part of the difference of time noted must be charged to the greater or smaller rapidity of the act of recognition; the entire process in each case being the transmission of a sensation (touch, hearing, or sight) to the brain, its recognition, the willing of the signal agreed upon, the transmission of the order to the muscles of the hand, and the movement of those muscles. Thus it would appear that less time is required for recognizing a touch than a sound, less time to hear than to see. But what part of the fifth, sixth, or seventh of a second, as the case might be, was consumed in the act of recognition?

Donders was successful in answering this question by the use of several forms of apparatus, involving entirely different methods, yet yielding the same results. He found, for instance, with the "noëmatachograph" that the double act of recognizing a sound and willing the response required seventy-five thousandths of a second. Of this time, forty thousandths of a second were required for simple recognition, thus leaving thirty-five thousandths for volition. With the "noëmatachometer" he found that the same time, forty thousandths (or one twenty-fifth) of a second, was required to judge which was first of two irritants acting on the same sense. A slightly longer time was required to judge the priority of signals acting on different senses, as a sound and a light. It also took longer to recognize a letter by seeing its form than by hearing its sound.

This in a man of middle age. Young people thought quicker, but the difference was not great. In all the experiments the time required for a simple thought was never less than a fortieth of a second. In other words the mind can perform not more than twenty-four hundred simple acts a minute, fifteen hundred a minute being the rate for persons of middle age.

From these figures it will be seen how absurd are many popular notions in regard to the fleetness of thought, how exaggerated are the terrors of remorseful memory that moralists have invented for the moment of dying. And we may reasonably "discount" also the stories told by men saved from drowning, cut down before death by hanging, or rescued from sudden and deadly peril from other causes. No doubt a man may think of a great multitude of experiences, good or bad, in a few minutes; but that the thoughts and emotions of a long life may surge through the mind during the seconds of asphyxiation are manifestly impossible.

Admit that the speed of mental action is abnormally rapid at such times, say twenty-five hundred simple cognitions a minute, or 150,000 an hour. If a man were an hour in drowning, instead of a few minutes, and all the time be given to a mental review of his life, he would, if forty years old, have time to give ten thoughts of the simplest character to each day that he had lived. In other words memory would have time to review the experiences of at most the hundredth part of one second out of each day's waking thousands.

THE INTENSITY OF TELEPHONIC SOUNDS.

The scale of intensities of the sounds perceptible to our ear is very great, a fact easily appreciable when the difference between the faint hum of an insect, audible at barely a yard's distance, and the thunder of artillery a couple of dozen miles away is considered. These intensities being relatively as the square of the distances, the first would be but a fraction of the second, the denominator of which would be 1,600,000,000, all other things being equal. In order to compare the intensity of the sounds transmitted by the telephone with the intensity of the primitive sound, M. Demoget has recently made some interesting investigations, an account of which we find in *La Nature*.

Two telephones were employed, one of which the operator held to his ear, while into the second instrument an assistant repeated a given syllable with a uniform intensity of voice. The sound transmitted by the telephone and also that reaching the ear directly were both heard, and it was thus easy to make a comparison between them.

At 288 feet distance the intensities appeared equal, the vibrating plate being held at a distance 1.9 inches from the ear. The relation of the intensities was then as 25 to 81,000,000; or, in other words, the sound transmitted by the telephone was only about $\frac{1}{3240000}$ of the sound emitted. "But," adds M. Demoget, "as the stations of the observers could not be considered as two points vibrating in space, it was necessary to reduce the ratio by half because of the influence of the ground, and hence to consider the sound transmitted by the telephone to be 1,500,000 times weaker than that directly communicated."

It is well known that the intensity of two sounds is proportional to the square of the amplitude of the vibrations, and hence it may be concluded that the vibrations of the two plates of these telephones were directly proportional to the distances, that is, as 5 to 9,000, or that the vibrations of the receiving telephone were 1,800 times smaller than those of the transmitting telephone. They may thus be compared to molecular vibrations, for those of the receiving telephone have already a very small amplitude. From the foregoing M. Demoget argues that the telephone as a machine is far from being perfected, since it transmits but $\frac{1}{3240000}$ of the primitive energy. Investigations looking to its improvement, he thinks, must be in one or the other of the two following directions: First, by attempting to augment the vibrations of the diaphragm of the second telephone by means of electricity from a battery; second, by augmenting the useful effect of the apparatus by improving the parts so as to give more amplitude to the vibrations of the transmitting telephone.

Following out these trains of thought, M. Demoget has placed, at a distance of 0.03 inch in front of the diaphragm of a telephone, one or more similar vibrating plates, in one of which was pierced an orifice of a diameter equal to that of the magnetized bar, and in the second a larger opening. By this simple means, he states, not only are the sounds transmitted augmented in clearness, but in intensity also. At the ends of a line 96 feet long, disposed between the stories of a house, it was possible to converse in a very low voice. By this arrangement, the magnetic vibrating mass being greater in relation to the magnet, the electro-motive force of the currents is augmented, and consequently the vibrations of the plates of the second telephone are also increased.

PROGRESS AT THE PATENT OFFICE.

The Commissioner of Patents has just issued an order to the examining corps relative to pending cases in arrears, which will command the hearty approval of every one having business before that bureau. As we have taken occasion to point out already, thousands of people are inventing at the present time who never did so before, in the hope of retrieving impaired fortunes, through disposal of their patented devices. Especially to these inventors delay is a hardship; to all classes of patentees it is annoying, and sometimes prejudicial to their interests, while it adds materially and unnecessarily to the labors of all those who have constant dealings with the office.

The present official staff appears to be large enough to keep the work clear of arrears if all the members of the staff were strict in attention to duty. But the members of the bureau are so mutually dependent that laxity on the part of any is certain to hinder and affect the labor of all. No matter how hard a commissioner may strive to make his administration satisfactory, he will labor uselessly if he does not insist upon real industry on the part of his subordinates. If one, Examiner A., conceives the idea that sitting with his heels on a desk from 10 A.M. to 2 P.M. reading newspapers is most promotive of inventors' benefits, Examiner B., although possessing conscientious ideas about what he ought to give in return for his pay, will see no harm in putting a tough case over until to-morrow or next week, and, in brief, the office will ultimately adopt the pace of its slowest member.

When Commissioner Spear strikes at the root of this difficulty and peremptorily orders, as he has lately done, that working hours be extended until 5 o'clock P.M. until further notice, that all the force in the examiners' rooms shall be kept at work, and that examiners shall make daily reports of what they and their assistants have accomplished during the preceding day, he is doing inventors a genuine service; and now that he has put his hand to the plow we trust that he will not look back until his bureau is as well regulated and as free from abuses as any properly managed private business house.

COLOR BLINDNESS.

Mr. T. F. Nelson, in the *Chicago Railway Review*, remarks of color blindness: This defect but rarely assumes the form that would be termed absolute color blindness or want of any sensation of color. Where this form is perfectly developed there is generally a sharp, well-defined appreciation of differences between light and shade, or even between the finest grades of apparent brightness or intensity; but recognition of color is entirely wanting; there being no distinction whatever between different colors having the same degree of intensity. A curious fact might be noticed in this connection, that these defects are but rarely found in women.

The more common form is that caused by the absence of perception of one of the three fundamental colors. These are mentioned in the order of their comparative frequency; namely, where the elementary sensation corresponding to red is wanting; next, the absence or imperfect perception of green; and third, of blue is excluded. It will be noticed as a remarkable fact that the first two mentioned are now used to make up the entire code of railway signals, and that this defect for red occurs more frequently than for any other color. This is an item of the greatest importance in railway and vessel management, since red is almost always used for the danger signal. To add still further to the deceptive and dangerous character of the defects, I have, in the course of my experiments, found a number of persons who were unable to distinguish between the primary colors at night, while their perception or sensation of color by daylight was apparently perfect. Again, I have found another anomaly which, until it has been more thoroughly investigated and the real causes that produce it are understood, I shall designate as a form of color blindness, although I am in doubt myself as to its dependence upon any of the principles that enter into that defect; this is an inability to distinguish between or to recognize the primary colors at certain distances, varying more or less in individuals. This was found to be the most difficult of all defects to detect in the various cases I have examined, amounting to some nine or ten, in the regular course of my business as optician during the past three years. I have found no two of them at all alike, except in general results.

I have kept records of various accidents that have occurred, both upon land and water, during the past few years, and I have gathered such information about some of them as I could get outside of official sources; often I was unable to get any of any value; but I am convinced beyond a doubt that a large proportion of them could have been traced to this defect for a correct solution as to the primary causes of the accident. The query has been made, If these defects in their various forms are as numerous and of such a dangerous character as has been shown, how can we account for such a comparatively small number of accidents occurring which might be charged to them? I have attributed it to the high average intelligence and acquired cautiousness of engineers and pilots as a class. They have become so accustomed to be on the lookout for danger that their suspicions are easily aroused, which creates a sort of instinct that governs their actions, and they do not recognize but that their perceptions are correct. My convictions in this respect have been greatly strengthened within the past few months, there having been related to me some experience with an engineer who was continually making narrow escapes, and, after watching his actions under different circumstances for a time, color blindness was suspected, proved, and afterward acknowledged by him. The correctness with which he formed conclusions under the existing circumstances would indicate that he had some means by which he was enabled to form a plan of action, but he declared that he had nothing upon which to base his actions but the cautiousness acquired in that branch of service.

It could be claimed that this illustration lessened the importance of perfect vision, and rendered it of no great consequence whether a person was defective in this particular or not, so long as he formed judgment correctly. This might be true if vision depended upon judgment or instinct; but as we form judgment in a large measure by comparisons upon impressions received through the medium of vision, it will be apparent to all that it will be impossible to form correct judgment when the basis upon which it is formed is imperfect. It is quite possible that such a person may continue to make narrow escapes, falling upon the side of safety each time; but as there is no natural law by which his judgment is made positive and certain, the very next occasion may by the merest chance result in a serious error. In investigating all of the different forms of color blindness before mentioned, I have invariably taken into consideration the quickness of perception. This I have found varied quite as much in the different individuals, and even in the same person at different times, as the defect has differed in form and degree. The correctness and quickness with which judgment is formed and will power exercised after the perceptions are received by the mind through the medium of the senses, depend in a great measure upon the physical condition of the body. I have found that very slight physical or mental weariness produced results which showed a difference of between 80 and 90 per cent in the time consumed.

The Advantage of Illustrating an Invention.

Messrs. MUNN & Co.:

Gentlemen: I am more than ever convinced of the merits of your paper as a medium of the highest order for reaching the intelligence not only of this, but of foreign countries, and that it has no equal. I know this, for since the illustration and notice of my hydraulic engine appeared in your issue of March 9, 1878, I have been constantly in receipt of a vast number of communications from all portions of the United States, and not a few from foreign countries. All these communications, with just three exceptions, come from those directly interested in an economical power, a great proportion of these communications being *bona fide* orders.

I am in justice bound to award to your journal credit for bringing me a larger proportion of orders than any other source has brought. Yours truly,

Kansas City, Mo.

JAMES TALLEY, Jr.

SLOTING MACHINE.

The accompanying illustration represents a very powerful slotting machine recently designed and constructed by W. Collier & Co., of Salford, England. This machine is intended for the heaviest class of engine and rolling mill work, and great care has been taken in its design and construction to insure uniformity of strength in all the details, so that the heaviest cuts may be taken without either danger of breaking or springing in the machine. It will be seen from the engraving that the machine is of the ordinary type, with a lever quick-return motion, so arranged that not only is the ram raised more quickly when it ascends, but in the cutting or descending stroke about two to one in power is gained by the lever. The machine takes in articles 13 feet 6 inches in diameter, and has an adjustable stroke up to 4 feet. The circular table is 8 feet diameter, and has worm teeth cut from the solid metal in its periphery, for self-acting circular motion. The traverse of the tables is 8 feet longitudinally and 8 feet transversely, and of course self-acting variable feed motions are employed in the longitudinal, transverse, and circular movements, while a quick hand motion is also fitted to each.

The foot of the machine which carries the tables is made extra long, so that the tables may be wound to the front, and a heavy casting or forging be placed upon them by means of a traveling crane, and then be wound or slid back underneath the cutting tool. The advantage of this is obvious, for it enables the machine to be loaded and unloaded without the crane having to pass over the machine itself, which stands 23 feet high. The slide in which the cutting ram works can be raised and lowered by a screw, so as to form a bearing to the cutting ram, close down to its work. The position of the cutting ram in this slide can be altered by a man standing on the table of the machine; this is done by placing a small worm wheel in the bottom end of the screw in the ram, and by means of a small cross shaft, with a worm gearing into this worm wheel, and a square in the end of the shaft, a man standing on the table can, with a screw key, raise and lower the ram without having to use a ladder to get to the top of the ram in the usual manner. An enlarged detail

arrangement of the main wheel, lever, and connecting rod is shown separately.

The foot or front portion, on which the table slides, is placed on the top for the convenience of the workman standing on it, and the table beds in three places upon it, one in the center directly under the cut and one on each side. To provide for slotting awkward pieces, a round hole, 3 feet 6 inches diameter, is cast in the foot of the machine to permit an object to pass through, if necessary. Great care has been taken to secure wide bearing surfaces to all the working parts, and all V slides are made to bed on the top and angle, as well as the bottom surface. The machine is very powerfully geared, and driven by belts 7 inches wide. The frame is cast in two pieces, to enable it to be carried on the railway, the joint being as indicated on our engraving. The total weight of the machine will be 65 tons. The heaviest casting is about 24 tons. It will be seen from the foregoing particulars, which we obtain from the *Engineer*, that this is one of the heaviest slotting machines ever made.

SEA WATER AS A BEVERAGE.

The distressing effect of sea water when swallowed in quantity is known to every one; the maddening effect of a continued use of it as a beverage by castaways at sea is familiar to all readers of shipwreck narratives. Perhaps no more terrible experience ever falls to the lot of humanity than to be afloat on the ocean, with

"Water, water everywhere,
And not a drop to drink."

Yet it is an experience which every one is liable to who goes to sea. To seafaring people it is a constant menace; yet it is not impossible to accustom the stomach to the use of sea water habitually and without discomfort. The capacity of the human organization to adapt itself to new conditions, even to the extent of becoming indifferent to violent poisons such as arsenic, has been abundantly proved; and accordingly there seems nothing incredible in the report that the inhabitants of Easter Island and isolated coral islands such as the Paumotu Islands, where rains are infrequent and springs unknown, are accustomed to use sea

water habitually as a beverage. It is scarcely more nauseous than many saline spring waters that people learn to relish; and once the system has become used to the reception of it no unpleasant or disturbing results will follow its habitual or occasional use. In many parts of the world the natives drink freely of brackish waters which strangers cannot tolerate; and we have been told of sailors who have trained their stomachs to receive sea water as kindly as fresh water. In view of the constant risk which seafaring people run of being caught with a short supply of ordinary potable water it would seem to be a wise precaution on the part of all such to master the situation in advance. By gradually increasing the proportion of sea water in their daily drink, they might learn to use sea water not only with impunity but with life-saving effect in emergencies, and that without any serious preliminary discomfort.

[A contributor sends us the above, based apparently on authenticated fact, but it seems to us rather doubtful. In every quart of sea water there is over an ounce of solid salts, the principal of which is chloride of sodium. From half an ounce to an ounce of this acts as an emetic and purgative, and on the other hand, a quart of water per day is about as little as will comfortably support life. It is difficult to see how any one can become habituated to living on a strong emetic, which must be taken in large doses at the very beginning and not in minute quantities as in the case of arsenic. As for sailors habituating themselves to sea water drinking there is little need of their so doing. A shallow pan filled with salt water, covered with an inclined plane of glass and exposed to the sun, is a very simple way which is almost always available for converting salt water into fresh. The solar heat causes evaporation, and the vapor condensing on the glass is caught in a receptacle.—Eds.]

THE iron product of the Lake Superior district during 1877 amounted to 1,020,859 tons, valued at nearly \$4,000,000. It is thought that, considering the depressed state of the iron market, this showing is a good one, the output being larger than was expected, although but few mines were worked at a profit.

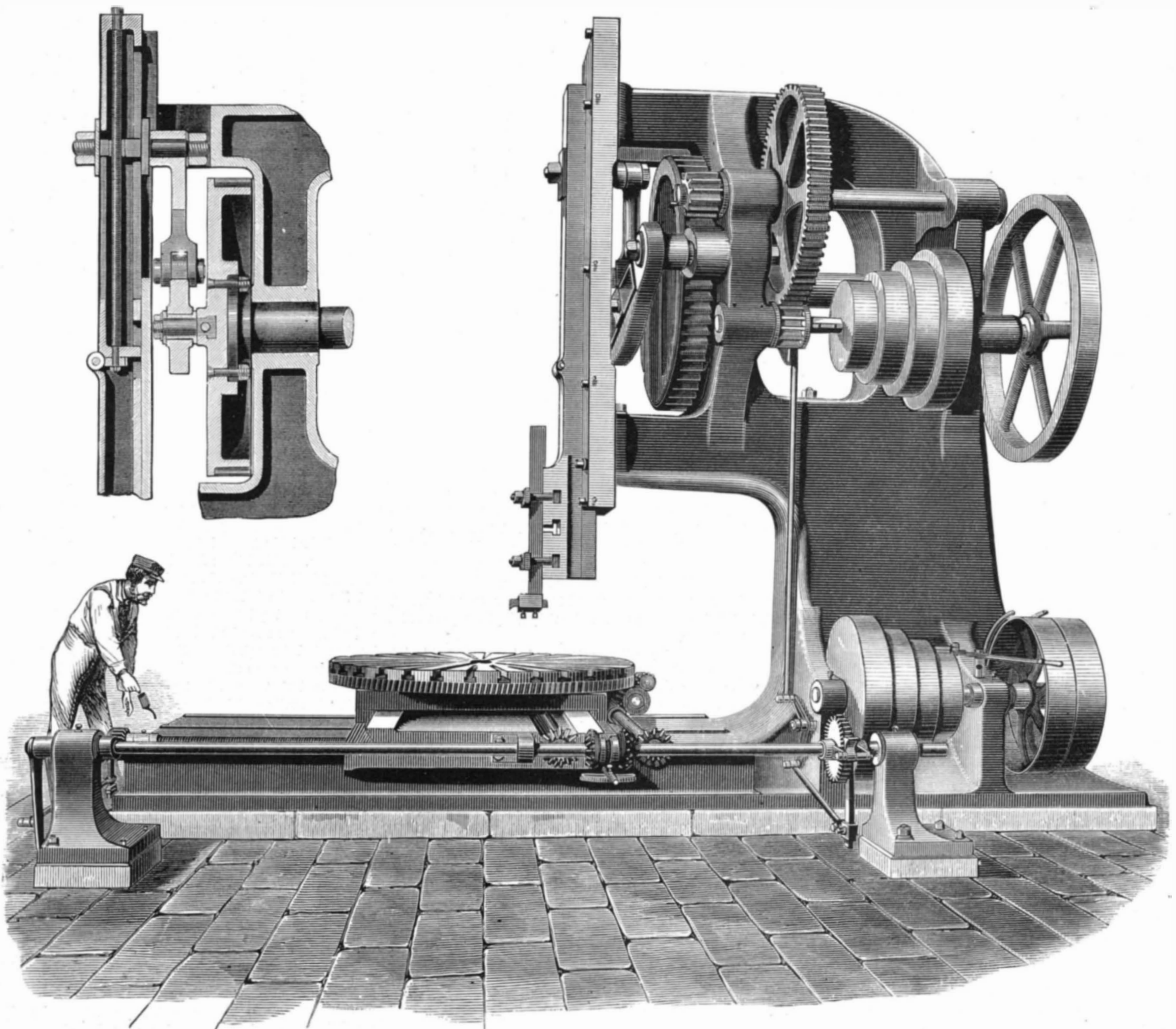

SLOTING MACHINE FOR HEAVY WORK.

IMPROVED CIRCULATING GENERATOR FOR STEAM BOILERS.

The principal advantages claimed for the invention herewith illustrated are a large saving of fuel, the rapid generation of steam, and increased durability of the boiler. The engraving shows the brick wall on one side of the setting broken away so as to give a clear view of the circulating apparatus and other parts underneath, and attached to, an ordinary horizontal boiler. D is a riveted steel drum placed on a brick bridge wall, which is lowered so as to allow the top of the drum to be of proper height in relation to the grate and opening for the products of combustion. Through pipe, N, the water passes from the bottom of the boiler into this drum, where it is converted into steam and superheated water to a temperature higher than that in the boiler, to which it returns with great velocity through pipe, H. A constant circulation is maintained and the formation of scale over the furnace thus prevented. Besides the gain in evaporation, which is a very important feature, there is also another advantage in having lime and other impurities in the water pass into the drum.

The peculiar arrangement of pipes, G and H, is such that impurities cannot return to the boiler, but can be blown out through pipe, F, or if necessary, altogether removed by means of the hand hole, E, which is placed at end or back of drum as may be necessary. In the rear of the drum, and extending to the back connection wall, is placed a coil of heavy lapwelded pipes, A A, which rests on bearers let into side walls; this coil is connected with the boiler at back end by pipe, P, and at the top by pipe, J; it is also connected with the feed pump by pipes, M O, and their branches. A deflecting wall resting on a heavy iron bearer is also built under and close to the boiler at the back end, as shown in the engraving. The combustion of gases ignited in the furnace is maintained the entire length of the boiler in the coil chamber. When the flame strikes the deflecting wall it passes through the openings between the coil pipes and returns backward through the tubes in the boiler. The feed water for the boiler enters this coil from the heater in use or in a cold state, by pipe, M, and in its passage to the boiler, which is very rapid, it becomes heated to a temperature ranging from 250° to 300°.

To preserve the coil from any liability to burn, as well as to secure circulation from the back of boiler, a connection is made by pipe, P, with a pipe leading to coil, and an ingeniously constructed swing check valve, invented by the patentee of this circulating generator, is attached to this pipe. This valve is partially open when the feed pump is operating, and the water from the boiler unites with the feed water, raising the temperature of the latter to nearly boiling point before it enters the coil. When the feed water is stopped the check valve opens wide, giving unobstructed passage of the water from boiler to coil, through which, by its increasing temperature, a rapid circulation to the boiler is maintained. By opening valve, K, the coil can be cleaned. (We are informed, however, that there is no liability to clog even where this precaution is neglected, so rapid and continuous is the circulation.)

The manufacturers state that the device causes a greatly increased power of boiler, "a gain of over fifty per cent being shown in some cases, due to the perfect consumption of fuel and the utilization of heat, by which an evaporation of twelve pounds of water to one pound of coal is frequently attained." The circulation is claimed to be continuous, giving equalized temperature, even expansion, and contraction and freedom from scale deposit; also rapid loosening of scale if formed in a boiler previous to the generator being attached. It is further claimed that there is additional security against explosion, inasmuch as the feed water can never enter the boiler when fired, except at a temperature almost equal to that of the water already in the boiler. It has been found, we are told, that the temperature of the feed water sometimes exceeds that of the water in the boiler. Patented in 1876 and 1877. For further information address the Ironclad Manufacturing Company, of 52 Greenpoint avenue, Greenpoint, L. I.

The Star Finder.

Under this name a handy astronomical chart, or planisphere, with a movable horizon, has been published by Van Nostrand, of New York city. It exhibits the stars of the first three magnitudes which are visible on the parallel of 40° north latitude, and shows the boundaries of the principal

constellations. The chart furnishes beginners with a means of approximately solving a number of problems without calculation, it being simply necessary to adjust the movable horizon according to the date and hour, to determine the right ascension, declination, rising, meridian passage, or setting of any of the principal stars. To locate the planets, their positions are found by reference to an almanac.

IMPROVED SEWER GAS CHECK VALVE FOR STATIONARY WASH BASINS, ETC.

Sanitary engineers seem to be recognizing a fact which is becoming more and more apparent, that very much of the ill health and disease prevalent in cities and towns is attri-

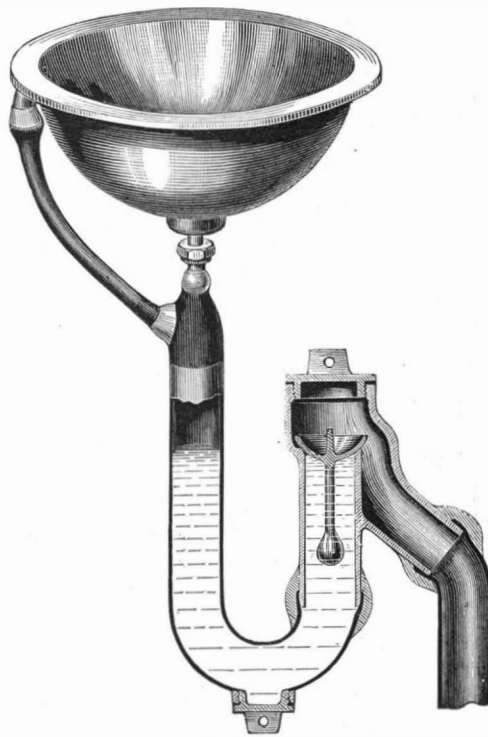

WARING'S SEWER GAS CHECK VALVE.

butable to defective drainage and imperfect sewerage. Physicians, also, testify now far more frequently than formerly that small pox, typhoid fever, and diphtheria are the consequences of uncleanness, breathing air rendered impure by the emanations of sewer gas, and the presence of effluvia from sinks, garbage, and decomposing refuse. There is no theory or mere imagination about such statements. The evil is at our very doors, in our homes, and all around us. No matter how many "modern improvements" are introduced or what attention is given to insuring warmth and comfort, in public buildings, business offices, and private residences, if provision is not made to prevent the admission of sewer gas, the air in that building is rendered impure and poisonous; it becomes injurious to health, and will steadily undermine the vitality and vigor of the strongest constitution. This evil, which is by far too common, can be remedied by property owners, landlords, and builders

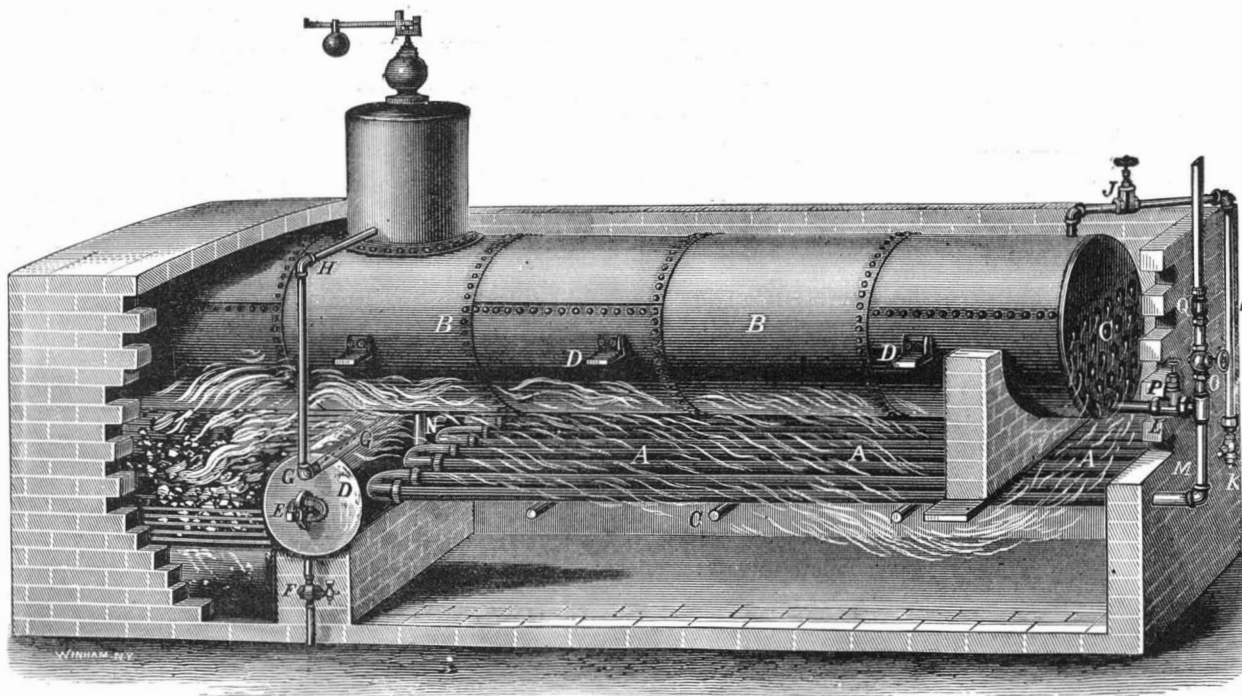

STEAD'S CIRCULATING GENERATOR FOR STEAM BOILERS.

adopting sanitary measures, and availing themselves of suitable and reliable contrivances for its prevention. One of the most recent inventions, which is neither complicated nor costly, but effective and valuable, is that invented by Colonel George E. Waring, Jr., of Newport, R. I., sanitary engineer, and is manufactured at the Jennings Sanitary Depot, A. G. Myers, Manager, 94 Beekman street, New York. Of this we give a representation by the annexed engraving, on reference to which it will be seen that the contrivance is a perfect safeguard against pressure of sewer

gas, siphoning, the transmission of sewer gas through the water, and all obnoxiousness. The engraving shows a wash basin, with the ordinary outlet and overflow pipes. The valve and water seal are drawn in section. The valve is convex on its exterior seat, concave on the surface exposed to the gas that may issue from the waste pipe leading to the sewer. The interior area exposed to the back pressure of gas is larger than the area in contact with the water seal, therefore, the valve is kept well down to its seat and prevents all possibility of gas escaping through the water to the apartment. The bulb steadies the valve, tends to maintain it in a vertical position, and weights it down on its seat. By removing the cap directly over the valve, the latter can be examined at any moment with the least possible trouble. This invention makes it absolutely safe to have any and all basins, baths, etc., that may be desired in any part of a public or private building. The check valve is water tight and steam tight; always stands tight shut except when escaping water opens it. It would be a protection against the escape of foul air into an apartment even if there was no water in the pipes, and it may be very properly considered a self closing door of a soil pipe, opening as it does at the least touch to let out, and permanently and hermetically closing against all admission of, foul air and sewer gas. This excellent contrivance may be seen at the Jennings Sanitary Depot, the address of which is given above.

Elias Magnus Fries.

By the death of this eminent scientist has been extinguished one more bright star from the galaxy of botanists that have shed such a luster on Sweden.

Fries was born at Smaland, Sweden, August 15, 1794, and was consequently, at the time of his death, which occurred on the 8th ult., eighty-four years of age. His father, a clergyman, was an ardent and accomplished botanist. As there were no boys of his own age whom young Fries could make his companions, he became the constant companion of his father on his botanical excursions, and hence at an early age acquired a fondness for the study of botany, and soon made himself master of the diversified flora of his native place. At about the age of twelve he came across a large and exceedingly brilliant toadstool—a species of *Hydnium*—and was then first incited to the study of the *Agarics* and their allies, that abound in Sweden more than in any other region of Europe. Before he had left school at Wexio he knew, and had given temporary names to, nearly 400 species. Entering the University of Lund, in 1811, he had for his preceptors the celebrated botanists Schwartz and Agardh. In 1814 he was made Docent of Botany, and shortly after published his "*Novitiae Florae Suecicae*," first part, the second following in 1823. The first important result of his researches in fungology appeared in 1815, under the title of "*Observationes Mycologicae*." Dissatisfied with the method of Persoon, he began, the following year, to construct a system of his own, which, developed in his great work—the "*Systema Mycologicum*," 1821-1829—has been universally adopted by cryptogamic botanists, and remains in use to the present day. His other great works on the fungi are "*Systema Orbis Vegetabilis*" (1825), and "*Epicrisis Systematis Mycologici*," which appeared in 1838, and was supplemented in 1874 by a second edition. In 1831 was issued his large work on another order of cryptogams—the lichens.

In 1834 he was made Professor of Practical Economy at Upsala; in 1847 he became a member of the Swedish Royal Academy, and in 1851 succeeded to the Chair of Botany at Upsala, which he resigned only a few years ago to his son.

The works of Fries are written, as all like works should be, in Latin, and are thus made available to students of every nationality. Fries displayed most wonderful tact in the discrimination of genera and species, and based all his descriptions on external characters. He displayed a singular prejudice against the use of the perfected microscope, and refused to avail himself of its use up to the time of

his death. Corda, Kunth, and other German fungologists, having, on this account, criticised some of his work, his annoyance manifested itself in a refusal to publish the manuscript of a "*Synopsis Ascomycetum*," in which he had included some 600 new species.

All the latter years of his life he lived at Upsala, in good health and in constant correspondence with botanists of this and other countries. It is a curious fact that his death occurred at the same place as, and but a few weeks beyond, the centennial anniversary of that of his great predecessor Linnaeus.

Up to within a short time previous to his death he was still engaged to the extent which his advanced though vigorous age permitted, in the study of the *Agarics*, which had been a favorite one from his youth. The persistent energy of this venerable worker is a fresh instance proving the truth of the common saying that students of nature and of science always die in the harness.

IMPROVED NUT LOCK.

We illustrate this week a simple, inexpensive, and easily adjusted nut lock.

It is hardly necessary to state that mechanics in all branches of labor have long been troubled with nuts jarring or shaking loose. By this device all trouble from this source is at once obviated. Its merit arises from a simple adaptation of the property inherent in all metals in a cold state, whereby by pressure they conform to the shape of a mould constructed of a substance harder than the metal compressed. A nut prepared as indicated in the engravings can be locked, unlocked, and relocked without removing it from its bolt, and if, by reason of shrinkage in the material bolted, it is necessary to tighten a nut, it can be done, and the nut relocked at will.

For carriages, sleighs, and vehicles of all descriptions, for agricultural implements and locomotives, for car trucks, looms, and machinery of every kind, to securely fasten lag bolts and fish plates, in fact, wherever a nut is used or can be used, there this device can be applied, and as the soft metals used (copper and tin and their alloys) are not readily oxidized, these nuts can be employed where there is a continued or intermittent submergence in salt or fresh water without injury. If desired, the nuts are so prepared that after locking the surface of the soft metal will be flush with the upper face of the nut; this form is for use where unshrinking substances are to be bolted together, and the nut is unlikely to be required to be unlocked. The nuts are prepared for locking, and can be used or not at will, the hole through the nut being countersunk at both ends, thus preventing the soft metal from unintentional displacement.

Fig. 1 represents a nut with a vertical hole through it, filled with soft metal, to be driven into the serrations of the washer.

Fig. 2 represents a carriage bolt and nut, with a horizontal hole through the nut, filled with soft metal, to be driven into the notches in the thread of the bolt.

Fig. 3 represents a portion of material bolted, serving as a washer, the locking in this instance being effected, as shown, upon the head of the bolt.

Fig. 4 shows a cross section of a bolt and nut, with a soft metal plug extending through the nut; the end of the hole adjacent to the washer may be more or less countersunk, and thus a larger or smaller bearing may be had on the washer, as desired, without weakening or injuring the nut. The merit this lock nut possesses lies in these facts, that nothing is required externally to convert ordinary nuts into lock nuts, and that the device can be applied to bolts, washers, or nuts wherever in use, at a trifling cost. Nuts, bolts, or washers prepared under this patent for general or special service can be furnished in any quantity desired, and any further information will be given upon application to Daniel Cushing & Co., Metal Workers, Lowell, Mass. Patented December 11, 1877.

Communications.

A New Motor Wanted.

To the Editor of the Scientific American:

The recent Barclay street explosion brought out a list of similar occurrences, all of which go to establish the simple fact, that finely divided matter of the combustible sort, when intermingled with air in certain proportions, forms an explosive that only requires ignition to demonstrate its power. This hitherto inutilized motive agent, if properly developed, may perhaps be made available in one way or another.

It is not unreasonable to suppose that wood and various kinds of combustible refuse, when reduced to impalpable powder, might be utilized in an engine of special construction, contrived to introduce into an explosion chamber a certain quantity of the powdered combustible and air.

We are all familiar with the gunpowder engine, the gas engine, and the more recent hydrocarbon engine. These are examples of the successful application of explosives to the propulsion of machinery, and we see no reason why wood and other combustibles, instead of being burned under boilers, should not be reduced to the proper state and exploded in a suitable engine, so as to be available as a source of power.

It remains for our inventors to develop and bring out this motive agent, and to devise a motor adapted to its use.

GEO. M. HOPKINS.

Proposed Change in Locomotive Strokes.

To the Editor of the Scientific American:

In the SCIENTIFIC AMERICAN of March 9 and March 30, 1878, I notice articles on "Locomotive Strokes," by Messrs. F. G. Woodward and John A. Holmes. As to Mr. Woodward's suggestion, permit me to state that there would be no advantage whatever gained by his proposed change. The

work, in foot pounds, performed by any steam engine in a given time is obtained by multiplying together the mean pressure per square inch on the piston, the area of piston in inches, and the number of feet traveled by the piston in the given time.

For example, if we assume a 16x24 inch cylinder, with a mean pressure on the piston of 40 pounds per square inch, the work performed per stroke is $40 \times 201.0624 \times 2 = 16,085$ foot pounds. Now, it can be readily seen that the proposed change would simply result in dividing the above product by 2, and at the same time multiplying it by 2, which would leave the amount of work per stroke unaltered. Of course the time required for one stroke of the piston must be the same in both engines, as we have assumed above, otherwise the power of the two engines would not be the same. On the other hand, there would be the objection of increasing the wear on the piston in consequence of its increased travel.

C. A. SMITH.

Columbus, O., March 27.

Cinders in the Eye.

To the Editor of the Scientific American:

I have often tried the remedy of putting flax seed in the eye for cinders, as suggested in your last issue, and have often found it efficacious, but too slow. I never knew the seed to cause irritation. They are inserted more easily when the patient is lying down or has his head well back, and must be put under the upper lid, else they will fall out. Another method, which I have never seen used by any one else, but which I suppose is used, is to fill a small sharp nozzle syringe with warm water, raise the upper lid from the ball, point the syringe under the lid at the outer corner, and shoot a jet toward the inner one. This is usually very effective.

A third way, common with medical men, can be easily practiced by any one. Let the patient look down (having

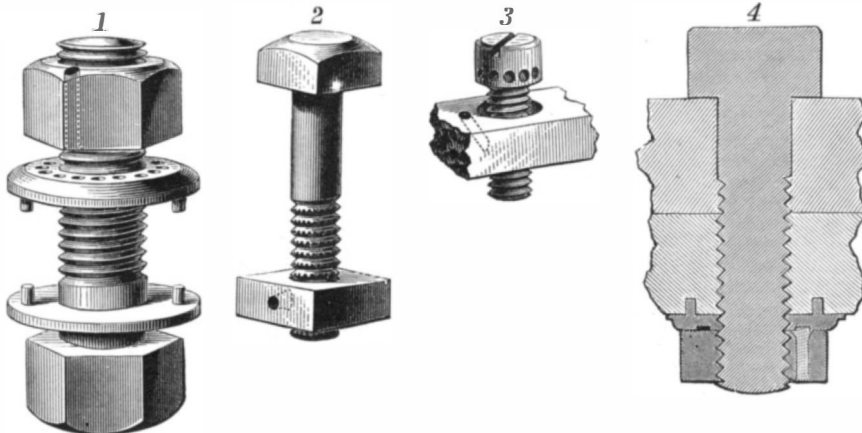

IMPROVED NUT LOCK.

the head thrown back), and let a person standing behind him turn the lid over a pencil or any small instrument; a nail will do. The offending substance is at once brought to light, and can be removed with a bit of cloth. Rest and a soothing wash usually complete the cure. Substances imbedded in the cornea or sclera are, of course, subjects for surgical treatment.

H. G. CHASE, M.D.

New York, March 28.

New Inventions.

An Indian Club, invented by Mr. E. M. Folk, of Brooklyn, N. Y., is of the ordinary shape externally, but has in its larger end a cylindrical chamber, in which are fitted a series of removable weights, held in place by heads and spring bolts.

Mr. F. M. Smith, of Vermilion, Dakota, has patented a device for Catching and Carrying Hogs, which consists of a cage having a detachable bottom, sliding end panels, and transporting handles.

An improved Specie Purse has been patented by Mr. J. C. Rundlett, of Portland, Me. It is made of flexible material, has a deep pocket for containing coin, and a shallow pocket which folds over the deep pocket, and has a space between the two pockets for exhibiting the contents.

An Automatic Fire Alarm, the invention of Mr. J. M. de Célis, of New York city, has a spring-acted arm carrying a button, which makes electric connection or otherwise rings a bell or explodes a gun, and which is retained by a block of wax, tallow, or other material melting at a certain temperature.

A Steam and Fume Box, invented by Mrs. E. DeLong, of Stone Church, Pa., is intended to be placed on the top of a stove to collect the steam from cooking vessels, preventing the steam and odors from escaping through the house, and keeping the food warm after being cooked. It is provided with sliding doors at the top and sides.

Mr. W. H. Savage, of Kingston, Ontario, Canada, has invented an improved Brush Bridler, formed of an adjustable metallic band, clasping the brush by means of hooks fitting into slits, and having straps suitably secured to the plate which rests upon the brush head.

Mr. F. H. Trenholm, of Charleston, S. C., has patented a Cart Body, constructed so as to prevent the contents from being lost or stolen. It is furnished with a cover hinged at its forward end, and at its rear end provided with a hasp, which passes over the tail board and is secured by a staple at the bottom of the cart body. The tail board is in two

parts, and is hinged in such a manner as to give access to the top, bottom, or sides of the body, as desired.

An improved Cigar Package, designed to retain the flavor and moisture of cigars under all circumstances, has been invented by Mr. Pierre Cauhapé, of New York city. It consists of hermetically sealed and moisture-proof envelopes or capsules of gelatinous material, preferably a mixture of gelatin, honey, and gum arabic.

Mr. W. A. Miller, of Rigdon, Ind., has patented a Wash Boiler in which a continuous circulation is maintained by means of an adjustable and perforated central tube, which conveys water and steam from below a false bottom and projects them upon the clothes.

An improved Animal Trap has been invented by Mr. J. A. Palmer, of Noble, Ill., by which each animal killed is removed from the trap, and the trap automatically reset. A revolving arm, actuated by a spring, delivers a blow upon the head of the animal in such a manner as to eject the latter, and a drop pawl resets the trap until the spring has run down.

Mr. E. Wilson, of Otto, N. Y., has invented a Spring Back for Vehicles, which is capable of being adjusted as to the height and tension of the supporting springs. It consists of a second back supported on adjustable side spring arms, and on C shaped rear springs, which admit, on being turned, the raising or lowering of the back.

An improved Kitchen Table, invented by Mrs. Josephine Bliss, of Pringhar, Iowa, has a number of boxes with hinged lids arranged along three sides, and a moulding board fitted into the space between the boxes. Sliding grates are arranged at each end, and drawers below the table.

Mr. G. H. Gerken, of New York city, has made certain improvements in the construction of Windows, intended to permit cleaning the sashes without removing them or necessitating reaching outside of the window. The sashes are centrally pivoted to end strips, so as to be turned on the pivots, and the joints of these end strips with the sashes are covered by hinged face strips.

A new form of Oil Stove, in which a number of original details are introduced, has recently been patented by Mr. H. L. Howse, of Sacramento, Cal. The manner in which air is led to the wick tubes is claimed to insure steady combustion and prevent the flame from being affected by cross currents.

An improved Heating Drum, for supplying a constant current of warm yet pure air to rooms, has been invented by Mr. W. A. Swaren, of Robinson, Ill. The air chamber has a series of alternating shelves, through which the air circulates, being admitted at a side opening and conducted upward to the registers. The passages for the smoke and gases of combustion are separated from the air chamber, but so arranged as to heat the air chamber effectively.

Improvements in the Running Gear of Wagons, for the purpose of obviating the strain caused by passing over uneven roads, are the subject of a patent recently issued to Mr. Wm. Ulrich, of Madison, N. J. The forward axle is made with rounded projections having a V shaped slot, into which enters the square lower part of the king bolt, thus permitting the axle to tilt without affecting the cross bar of the fifth wheel and the head block.

Mr. A. C. Fuller, of Middletown, N. Y., has patented a new Hat Folding Device, for producing hats known to the trade as "telescope" hats. It consists of metal bands, a receiver or die, heated by steam, and a rubber block operated by a follower, in an ordinary press.

An improved fastening device for Hat Mirrors, by means of which the mirror may be readily attached to the inner surface of the crown of any hat, has been invented by Mr. F. J. Hoyt, of New York city. A plate cemented to the back of the mirror has a boss, in which is a countersunk screw hole for receiving a screw which fastens the mirror to the hat.

One of the Highest Mountains.

According to recent geographical surveys, it seems that the Aconcagua Peak is the loftiest of the Andes range, and the highest in America. It is 100 miles east of Valparaiso, and nearly in latitude $32^{\circ} 30'$ south. Its actual height is not accurately known, but the measurements made by M. Pissis and other noted scientists make it reasonably certain that the elevation is between 22,400 and 23,900 feet above the waters of the sea. The French explorer made it 22,422, or four miles and 1,302 feet over, which would be 998 feet higher than the snowy summit of Chimborazo, as Humboldt measured the latter, when in 1802 the great German made his famous ascent of that mountain with Bonpland to a height of 19,286 feet. Aconcagua, seen from the Chilean seaport of Valparaiso, is shown only as a peak, towering above the other heights of the Andes at a distance of 100 miles or more inland, toward the sunrise. Aconcagua has been called an extinct volcano, but the best examinations yet made of its summit do not appear to bear out that idea. The recent observations make the height of the Chilean mountain 23,200 feet, and "probably" over that figure. The elevation of Mexico's highest mountain—Popocatepetl, or "Smoking Mountain"—is nearly 5,000 feet less than that of the Chilean peak, and Mount Shasta and Mount Hood fall short to about the same figure. Pike's Peak is about 9,000 feet lower than Aconcagua.

SOME NEW WORKSHOP APPLIANCES.

Most mechanics have experienced difficulty in setting work in a planer vise because of the liability of the work to lift when the vise screw is tightened. To obviate this, Mr. Babbitt, of the Harris-Corliss Engine Works, has designed for those works the chuck vise shown in Fig. 1.

In this chuck, instead of gripping the work with the vise jaws direct, two pivoted plates are interposed, which incline from the pivots towards the work. A and B represent these plates, and C represents the work, so that the strain of the plates upon the work is in the direction denoted by the respective arrows, so that the work is forced downwards upon the tops of the pins. The plates are made to bear, at the back of the hinge, upon the hollow curve in the chuck jaws, as shown, which relieves the pivot of the strain due to screwing the chuck tightly.

The pins are made adjustable for height to suit the work, being screwed into the disks, H, which are attached to spiral springs, which depress until the disks, H, meet the shoulder at I, resting solidly upon them.

A chuck recently constructed by Mr. Thomas, at the Free-land Tool Works of this city, has an excellent provision for holding thin work, either parallel or taper, true and level between the jaws. In each jaw of the chuck there is cut a small square recess, shown in Fig. 2 at C D. A is a strip containing a projecting piece fitting into either of these recesses, according to the height required for A, the pieces, B, serving for packing pieces. The work rests upon the narrow upper surface of B, which projects beyond A, while A grips the work. Now it will be noted that the jaws of the chuck act upon A to tighten the work, and the contacting surface between A and the jaws is mainly above the horizontal level of the part of A that grips the work; hence the force holding the work is in a direction to bind the latter close down upon the pieces, D, which, being parallel and true, adjust the work true of themselves, whether it be taper or parallel. It will be noted, however, that the work may rest upon the upper surface of A A, and be gripped by the vise jaws themselves.

The holding of thin work has long been a matter very difficult to accomplish without springing, and any application of the hammer not only penes the upper surface, but the rebound of the metal causes the work to lift in the chuck. By the construction shown in Fig. 2, the work will be set true whether the jaws of the chuck are worn untrue or otherwise. The movable jaw is operated by the screws, E F, the thread having one V and one square side. The nut lifts and falls by operating the lever, G, enabling the throwing out of gear of the nut so as to move the movable jaw quickly. The movable jaw, it will be noted, receives the pressure of the screws, H I, above the horizontal level of either A or B; hence the tendency is to close its jaw surface down upon the chuck face; but since this jaw slides upon the piece, K, and K slides upon the surface of the chuck, the bolts, L and M, bolt K and the movable jaw firmly to the chuck. The whole of the parts comprising the movable jaw will swing to suit taper work.

In Fig. 3 is shown a new protractor, designed by Mr. Swasey, at the Pratt & Whitney Co.'s Works. The set screws, by which the movable blades of ordinary protractors are secured, are often in the way, preventing the face of the instrument from lying flat upon the face of the drawing board or upon that of the work. In Mr. Swasey's protractor the blade, A, is attached to the circular piece, D, the latter being recessed into the square, B B, and marked with the necessary degrees of angle, as shown, while the mark, F, upon the square, B, serves as an index point. The faces of A, B B, and D are all quite level, so that the edges will meet the lines upon the work and obviate any liability to error. The piece, D, is of the shape shown in section at G, which secures it in B B, the fit being sufficient to permit of its ready adjustment and retain it by friction in any required position. The dotted lines indicate the blade as it would appear when set to an angle, the point, E, being the center of D, and hence that from which the blade, A, operates.

In Fig. 4 is a form of tap that is finding much favor for use in large tools. The thread is cut in parallel steps, increasing in size towards the shank, the last step (from D to E in the Fig.) being the full size. The end of the tap at A being the proper size for the tapping hole, and the flutes not being carried through A, insures that the tap shall not be used in holes too small for the size of the tap, and thus is prevented a great deal of tap breakage. The bottom of the thread of the first parallel step (from A to B) is below the diameter of A, so as to relieve the sides of the thread of friction and cause the tap to enter easily. The first tooth of

each step does all the cutting, thus acting as a turning tool, while the step within the work holds the tooth to its cut, as shown in Fig. 5, in which N represents a nut and T the tap, both in section. The step, C, holds the tap to its work, and it is obvious that, as the tooth, B, enters, it will cut the thread to its own diameter, the rest of the teeth on that step merely following frictionless until the front tooth on the next step takes hold. Thus, to sharpen the tap equal to new, all that is required is to grind away the front tooth on each step, and it becomes practicable to reverse the tap a dozen times without softening it at all. As a sample of duty, it may be mentioned that, at the Harris-Corliss Works, a tap of this class, $2\frac{3}{8}$ inches diameter, with a 4 pitch, and 10 inches long, will tap a hole 5 inches deep, passing the tap continuously through without any backing motion, two men performing the duty with a wrench 4 feet long over all, the work being of cast iron.

Transit of Mercury.

The arrival in New York city of the two French scientists, MM. André and Angot, who are sent officially to make observations on the transit of Mercury, indicates the interest with which that event will be regarded. They are to proceed to Ogden, Utah, there to make observations on May 6. Ogden has probably been selected for two reasons: It is upon very elevated ground, being nearly on the "divide" of the continent, and offers great advantages in dryness of climate and purity of atmosphere. It is also a point where the center of the transit will be nearly at local noon. The transit will occupy about seven and a half hours. Observations will be of service in determining

There are many raw fibers of great value, which are not nearly so well known as they ought to be, and upon which we have repeatedly treated. There are also fibers which could be put to a more extended use and application. For instance, jute, long a neglected article, the extreme cheapness of which at length forced it into notice, has now become a valuable item among the staples of commerce. Up to the present time its chief application has been confined to the production of the most inferior substitutes for flax and hemp. It has lately been found, however, that jute takes color better than any other vegetable fiber, and, as a textile, in this respect ranks next to silk and wool. Ramie fiber will doubtless take an equal rank, but of this we cannot so positively speak, as we have been shown some beautiful specimens of dyed jute in various bright colors, and it may confidently be predicted that these will be largely resorted to in future.

A new application of jute has already been shown from abroad, there being now in the trade specimens of jute curtains and table cloths of a very superior description, and which are likely to be extensively sold, being at once novel, elegant, and cheap. The curtains consist of a thick plain twilled jute fabric, which is dyed to a slightly brighter tint than the natural brown color of unbleached linen. Along the edge, to form a border, is printed a suitable pattern in chintz colors, the effect of which is remarkably good, contrasting as it does with the sober colored ground. Other similar goods, although really of an inexpensive nature, could be used with perfect propriety in the handsomest furnished houses, and they would be quite in keeping with the costliest furniture, simply on account of the exquisite taste displayed in their manufacture. Although we have said the cost of the material contained in these goods is very low, yet a comparatively high price is asked and obtained for them; for they have the appearance of being intrinsically much more valuable than they are.

Now, although we have given an accurate account of these articles, and the hint is worth a good deal to jute manufacturers, we venture to say that scarcely any one could realize the fine appearance of these beautiful commodities from what we have written; people must inspect and handle the objects for themselves in order to gain the full benefit of the instruction to be derived.

The Museum of Trade Patterns will afford this opportunity, and all the minute particulars relative to certain methods of manufacture will be seen at a glance—how an article is started in the loom, the size of weft and warp used, and the method of dyeing and finishing, when these form parts of any given class of manufacture. Experienced persons will readily perceive that if jute articles were sent in the ordinary way to the printers, with simple instructions to print

some nice object to form a border to a curtain or a center piece to a table cloth, in all probability some staring, vulgar object would be returned, which may fitly be included among low or common goods, which scarcely any one would tolerate.—*Textile Manufacturer.*

New Agricultural Inventions.

Mr. J. A. Shine, of Mount Olive, N. C., has invented a combined Cotton Planter and Fertilizer Distributer, constructed so as to open a furrow, drop the guano into it, cover the guano with soil, open a second furrow, drop the seed into it, cover the seed with soil, and roll the soil over it, and which may be adjusted to regulate or stop the discharge of either guano or seed, or both, and without stopping the machine.

An improved apparatus for Spraying Tobacco, invented by Mr. C. S. Philips, of New York city, is designed to secure the rapid and uniform application of the proper amount of moisture required to insure the fermentation of the leaf. The spray is distributed by steam nozzles pointing across the orifices of the supply tubes, and is applied on both sides of the tobacco from two opposite reservoirs. The whole apparatus is surrounded by a guard and is placed in a dripping pan.

An improvement in Plows, relating to the mode of adjustment of parts, has been patented by Messrs. P. H. Burns and W. C. McElhany, of Indiana, Pa. The standard is curved, having its landside part convex and the mouldboard side concave, and is notched and shouldered to receive the landside, mouldboard point, and share, in a novel manner.

MANUFACTURERS of textile goods who desire to obtain an economical black color, adapted for cotton, wool, or silk, are referred to the advertisement of Thomas' Strong Black, published in another column.

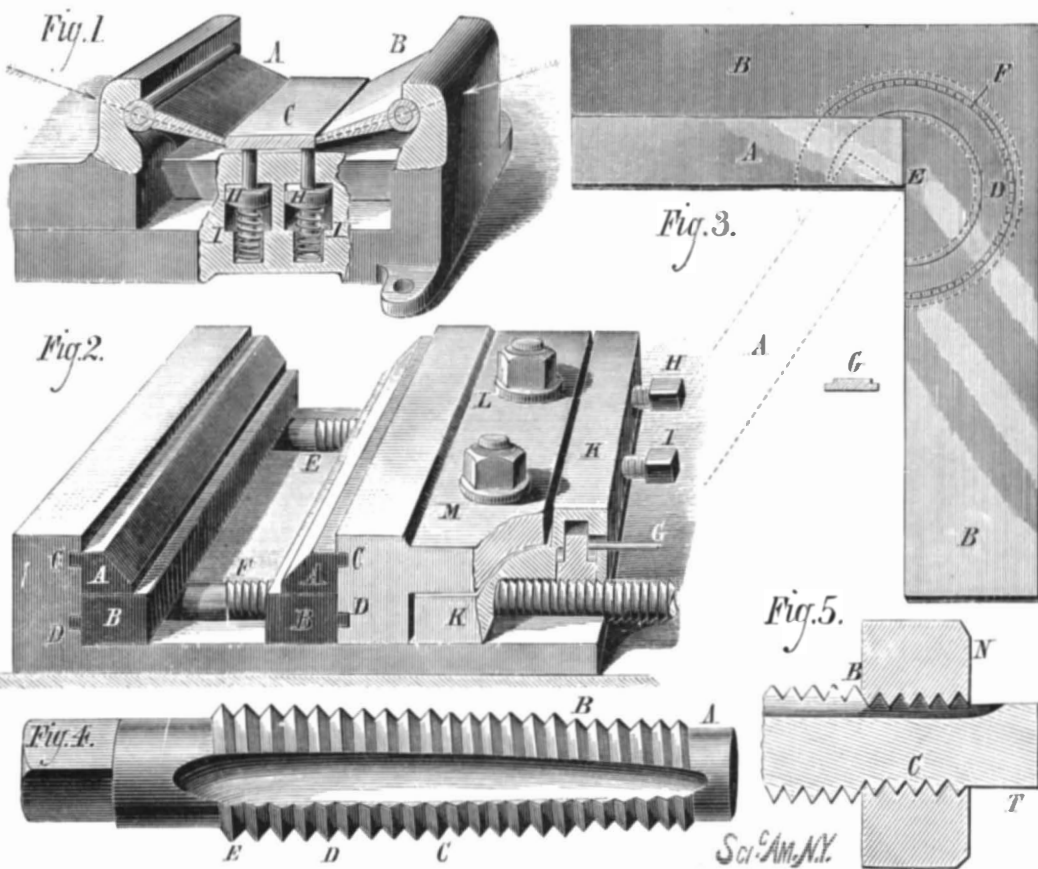

NEW WORKSHOP APPLIANCES.

the orbit of Mercury, and thus throwing more light upon the question of an intra-Mercurial planet, and also in furnishing data for fresh estimates of the distance of the sun.

Museum of Trade Patterns.

Steps have been taken for the formation of a Museum of Trade Patterns and Industrial Examples in Manchester, for the use of workmen and managers of factories, and to aid the great national requirements of technical education.

The promoters of the above scheme, in indicating the great advantages which must result from a large collection of trade patterns in an industrial center, to which masters and men alike can have access at times of doubt or difficulty, point out that no more striking example could be furnished of the value of models or patterns to manufacturers than that to be found in the case of Wedgwood, who produced accurate copies of the specimens of ancient art lent him by Sir William Hamilton, of vessels from Herculaneum, and the Barberina vase lent him by the Duchess of Portland, who, when it was offered for sale, outbid him for it by a hundred guineas. As a result of Wedgwood's work, pottery, from being one of the least understood of the fictile arts in the kingdom, has become one of the best and most successful; and, instead of now being obliged, as formerly, to import the bulk of our common pottery in domestic use from Delft, in Holland, we are now large exporters to other countries.

Many solid advantages are to be obtained from the inspection of a collection of patterns of the complete nature of that designed, which no amount of verbal instruction could furnish. The best informed person, thoroughly acquainted with all known processes of manufacture in which he may happen to be engaged, could take a useful hint from some other classes of goods out of his particular sphere, and appropriate it to his own benefit; which course would result in improvements in various branches.

IMPROVED DOVETAILING MACHINE.

The technical term dovetailing is one pertaining to joinery. Its form is similar to the tail of the dove, and the name is probably derived from the resemblance to that familiar object.

Dovetailing, or the formation of the dovetail joint or corner, is a means for making a substantial box or frame without the addition of any material or fastening other than the interlocked construction of the dovetail.

There are several styles of this joint in use; namely, the plain dovetail, which is placed in position not liable to exposure, and where strength without regard to appearance is the object; the blind or hidden dovetail, which is used where the front is to be shown; and the miter dovetail, which is to be used where the article to be joined is to be seen on all its sides.

The two former are those commonly in use, especially in furniture manufacturing, where we have a familiar example in drawers, where the blind or hidden dovetail is used for the front of the drawers, and the plain dovetail is used for the back of the drawers. The work of forming these dovetails has, until recently, been done almost entirely by hand labor, and the rapidity of production by an expert workman is such that it has been difficult to produce a machine to compete successfully with him, considering the cost of machine, and labor of conveying material to and from it.

Some of these machines have been constructed on plans to produce different forms of joints, but which were inventions of the routine of construction, and did not meet the approval of manufacturers. A new machine is now presented for the inspection of those interested in this class of work, constructed by Messrs. J. A. Fay & Co., the eminent wood working machinery manufacturers of Cincinnati, Ohio.

We herewith present an illustration of the machine, from which some idea can be obtained of its form, simplicity, and method of operation. It is designed for working two, three, or four pieces, cutting the dovetail on back, front, and side at one operation. The counter shaft is in the middle of the machine, carries the tight and loose pulleys, and the cone pulley, which conveys the power to the spindles, in which the cutters are placed. The cutter spindles are stationary. The material is placed on the vertical and horizontal plate, and held in position by cam rollers.

The pin, or male part, of the dovetail is cut on the horizontal table, and the mortise, or female part, of the dovetail is cut on the piece held on the vertical table. The operation is performed by the movement of the handle up and down, drawing the slide at each alternate motion of the handle; the construction of the guides being such that after being started it cannot be moved backward at all, nor forward more than the one notch desired, it being an actual impossibility to spoil any material after the operation is commenced properly.

This machine is in operation now in some of the prominent furniture manufactories, and giving entire satisfaction. Its simplicity and novelty will be readily apparent. It will do the work of twenty men with ease, far more perfectly and

rapidly than can possibly be done by the old method, and must become popular wherever introduced.

A patent on this machine has recently been granted, and any further particulars desired regarding it can be obtained by applying to the manufacturers, Messrs. J. A. Fay & Co., of Cincinnati, Ohio.

CENTRIFUGAL PUMPING ENGINE.

We give on this page an engraving of one of a pair of direct acting centrifugal pumping engines, lately constructed by Messrs. Gwynne & Co., of London, each of these engines being capable of raising 100 tons of water per minute to an elevation of 17 feet. The engines are fitted with cylinders

by an arrangement between the centrifugal pump and condenser. The whole of the machinery is made in only three pieces, all securely bolted together; this is specially necessary with such foundations as are found in low lands where drainage operations are being carried out. *Engineering*, from which we obtain these particulars, remarks that the engine illustrated is an admirable specimen of highly finished workmanship most creditable to its makers.

NEW INVESTIGATIONS ON GALLIUM.

M. Lecoq de Boisbaudran has recently successfully completed the history of the new metal gallium, the credit of the discovery of which is due to him. Through the most minute operations upon a mass of blende (sulphide of zinc), weighing 9,460 lbs., he has obtained, in collaboration with M. Jungfleisch, about two ounces of the metal, the richness of the blende in the same proving to be $\frac{1}{1000}$. The large mass of blende was first concentrated into a smaller one weighing 220 lbs., in which all the gallium was contained. Then follows a long succession of attacks by acids and of alternative precipitations, until the zinc, iron, lead, cadmium, indium, and other metals were eliminated, leaving the gallium in the residue of the solutions, whence it was obtained in a metallic state by the action of the electric current. The crystals formed are of a grayish blue color and octahedral. They were produced by introducing into the metal, cooled to about 18° above its fusing point, a platinum wire carrying a piece of solid gallium, on which crystals promptly grouped themselves.

The new metal is hard and malleable. It may be beaten out by the hammer, and is susceptible of polish, but it rapidly becomes brittle. In spite of its relatively great hardness it leaves grayish black marks on white paper. It keeps its brilliancy in a laboratory where the air is charged with acid vapors, and also in boiling water, but it tarnishes slowly in aerated water. It melts at 86° Fah., and may be kept in a liquid state in a hermetically sealed tube. M. Lecoq has prepared a portion which remains about as fluid as mercury, running from one end of the tube to the other when the latter is reversed, like melted wax. In color it is silvery white. It adheres to the sides of the glass, a property which prevents its use for the construction of thermometers capable of giving precise indications of temperatures above 800° Fah. This difficulty, it is believed, may be remedied, in which case the metal will prove of considerable value in making physical investigations. M. Lecoq has also prepared plates of gallium which melt by the warmth of the hand, and which are characterized by the

bluish reflections of their surface. In order to produce them the metal is cast between heated plates of glass; after cooling it is easily detached. Crystallized gallium prepared cold by the electrolysis of a potassic solution decrepitates when thrown into hot water and gives off bubbles of gas. By similar means the investigators have obtained a pasty metal which swells in tepid water and resembles ammonium amalgam. When kneaded in water at 104° Fah., this contracts and finally assumes the fluid state. M. Lecoq has sent numerous samples to the French Academy of Sciences.

**STENGEN'S DOVETAILING MACHINE.**

27 inches in diameter by 20 inches stroke, and work at the rate of 100 revolutions per minute. The steam in the boiler is supplied at 75 pounds per square inch, cut off at about one eighth of the stroke by adjustable expansion valves. The cylinders are steam jacketed all round, the jackets being supplied with steam direct from boiler. These engines have an ordinary ram condenser with valves for large outlet. A large air pump is provided for charging the centrifugal pumps, which have no foot valves, but in case of accident to the air pump the condenser itself is capable of charging the pump

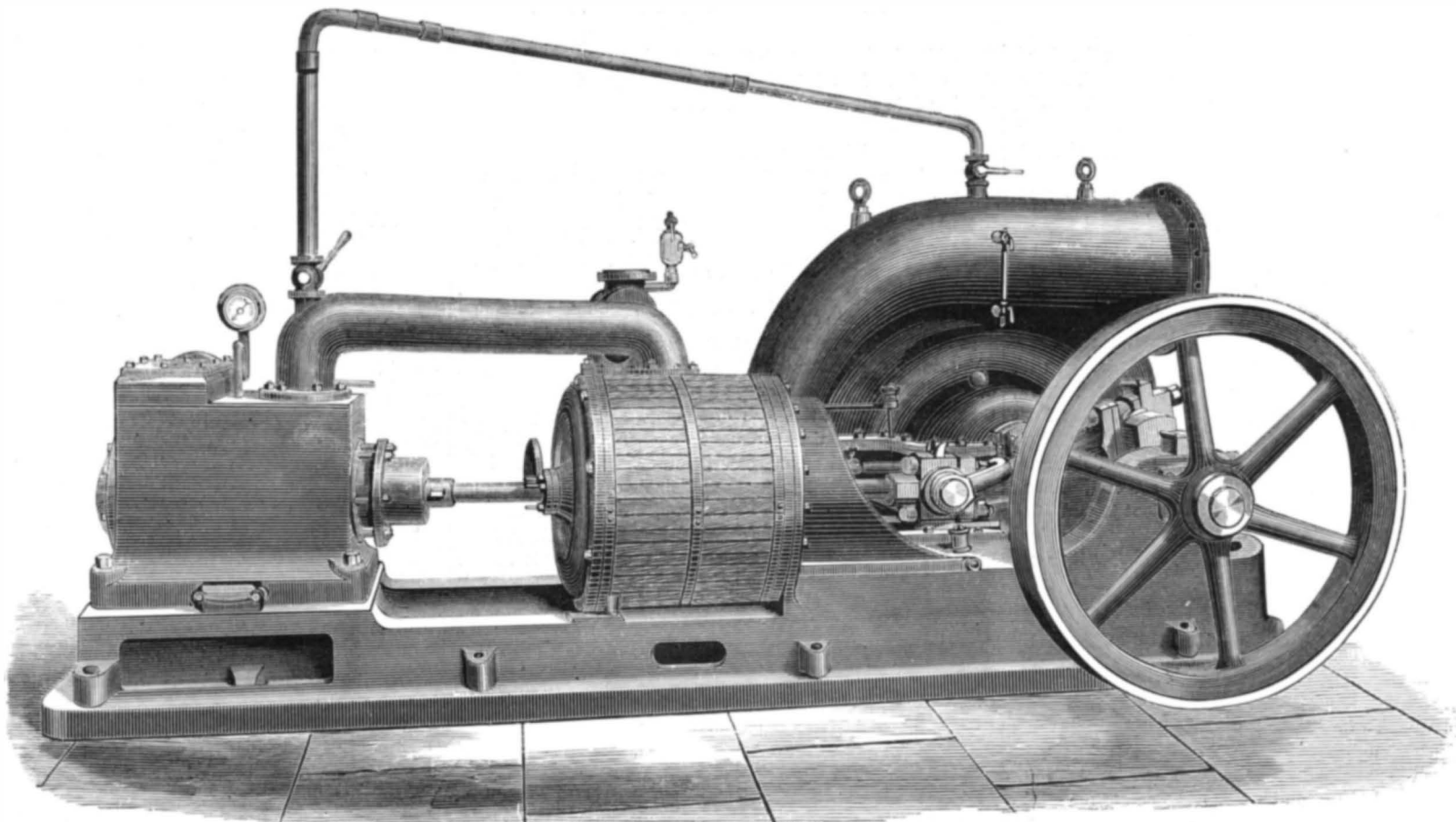
**DIRECT-ACTING CENTRIFUGAL PUMPING ENGINE.**

THE VICTORIA REGIA.

The two engravings given herewith represent the grandest of all water lilies, the immense *Victoria Regia*. In cultivation the plant is an annual, with a fleshy root stock, from which are produced leaves from six to twelve feet in diameter. These are fixed to the petiole by the center, and have a margin turned up as a border, as shown in Fig. 1, from two to three inches high, giving the leaf the appearance of a huge tray. Their upper surface is of a rich green color and studded with small prominences. The lower surface, purple or violet, is traversed by ridge-like veins, which divide the whole into compartments, while both veins and stalks are covered with spines or prickles. These enormous leaves are capable of sustaining a large water fowl, and by placing a board upon them to distribute the weight they will hold up a child of ten years of age. The flower is of two days' duration, and is exceedingly fragrant. It is cup-shaped, and measures from twelve to sixteen inches across. In cultivation the plant requires a tank 20 or 30 feet across and from 3 to 4 feet deep, with special arrangements for heating the water to 80° or 85°. It is indigenous to the river Amazon and tributaries.

Telephone Notes.

It is now well known that if the wire of a telephone be extended parallel to telegraph wires, and supported on the same posts, the clicking of the telegraph instruments will be distinctly heard in the telephone, so that messages passing can be read. This opens a new war utilization of the telephone, as it will be necessary simply to carry its wire near an enemy's telegraph line to read his dispatches, without tapping his wires.

Another new use of the telephone is in the Norwegian herring fisheries. The fishing season takes place when the herrings come into the shoals to deposit their eggs; but it often happens that the fish accomplish their purpose and go back into deep water before all the fishermen can be warned. Some 120 miles of submarine cable have been laid and telephones connected with it, so that all the fishermen on the coast can be immediately notified.

The telephone is a very simple contrivance, and it would seem that nothing could be more direct than the transmission of the voice to the ear of a listener; yet no less than eight transformations take place. The muscular effort of the speaker is transformed (1) into air vibrations; (2) into metallic vibrations; (3) into magnetic waves; (4) into electric induction; (5) into magnetic induction; (6) into metallic vibrations; (7) into air vibrations; (8) into vibrations of the auditory apparatus of the hearer.

The Improvement of Southern and Western Rivers.

The Annual Report of Capt. W. R. King, U. S. Engineers, for the year 1877, as an appendix to the Report of the Chief of Engineers, has just reached us. The report embraces the details of work on the following rivers:

1. The Tennessee above Chattanooga.—The object of improving this part of the river is to secure a low-water channel of sufficient depth for steamboats and other crafts across the numerous bars and shoals between Chattanooga and Knoxville, by the excavation of rock and gravel, and by building rock dams to contract the width and thus increase the depth of the water way. The work of the year was directed to the removal of sixteen obstructions. There were also about 105 cubic yards of gravel excavated, and many snags and overhanging trees removed. Below Chattanooga the obstructions consist of shoals; on the Elk river shoals no work has been done; on the Big Muscle shoals the work of enlarging and rebuilding the old canal around the shoals has been carried on under six contracts, all but one of which have been closed and completed during the year; on the Colbert shoals, which form the most serious obstruction to navigation on the Tennessee below the Muscle Shoals, considerable work has been done, and the improvement would have been completed had it not been for unusually high water.

2. The Cumberland River.—Below and above Nashville to the Kentucky line, a large quantity of stone has been excavated from the channel and quarried for dams, and a large number of snags, loose rocks, and overhanging trees removed at various points. The most formidable obstruction between the mouth of the Cumberland river and the Great Falls is known as Smith's Shoals. It consists of a succession of bad shoals over 8 miles long, and with a fall of 55 feet. The improvement of these shoals is very much needed to enable ves-

sels to reach the coal fields in the vicinity of Rock Castle river, as well as to furnish an outlet for the agricultural products of the country. The work on this section has consisted in the excavation of 6,120 cubic yards of rock, one half of which has been put into dams. From Smith's Shoals to the Falls of the Cumberland, nothing was done.

3. Coosa River, Georgia and Alabama.—The obstructions in this river consist of shoals, some of them of formidable character and costly to remove. Work has been commenced on 13 shoals, upon which there was less than 2½ feet of water at low tide. The object to be gained in the improvement of

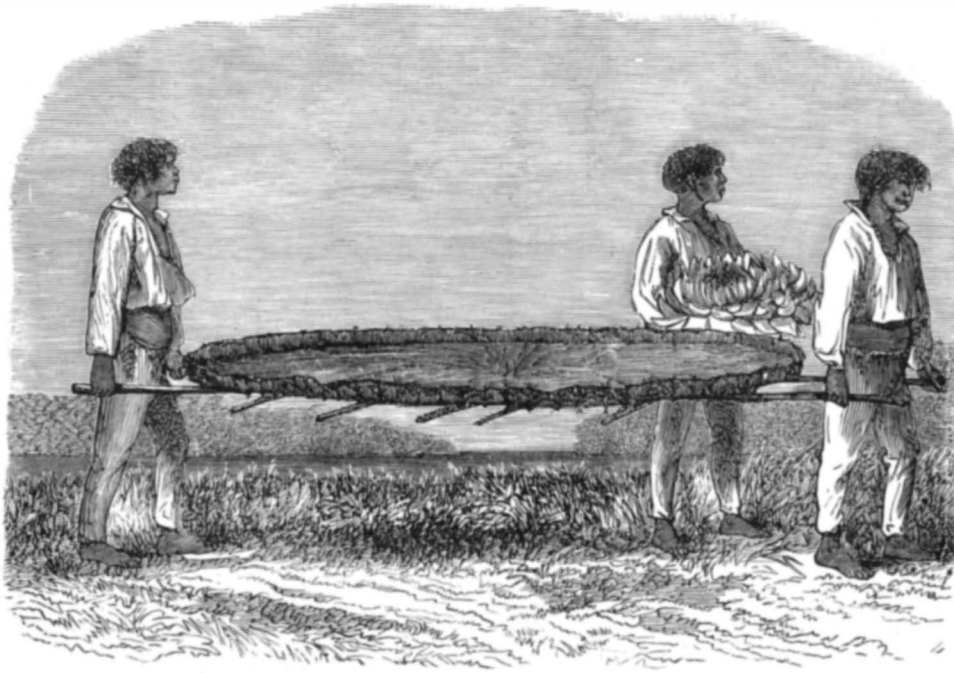

Fig. 1.—LEAF OF THE VICTORIA REGIA.

this river is the opening of the coal fields of St. Clair county, Alabama, to the people of Rome and the owners of various iron works along the Coosa, which are languishing for want of cheap coal, and also to furnish an outlet for the agricultural products of Northeastern Alabama and Northwestern Georgia; and it will supply an important link in a chain of waters of over 800 miles in length.

4. Hiwassee River, Tennessee.—The obstructions in this river consist of shoals. Matthew's Shoals and Magil's Island Shoals were selected as the first to be improved. Work was commenced on them and making good progress at the end of the year.



Fig. 2.—THE VICTORIA REGIA.

5. Ocmulgee, Oostenaule, and Coosawattee Rivers, Georgia.—No work has been done on these rivers.

6. Etowah River, Georgia.—The improvement of this river, if undertaken, will be very costly and difficult. Owing to the great number of shoals and rapids, the improvement would necessitate a series of locks and dams, some ten in number. Although Congress appropriated \$10,000 for the work, the engineer in charge learned from conversation with people living on its banks that there is no local interest which can be benefited by local improvements, and that

there is no demand whatever for navigation from one point to another along the course of the stream itself, and, as far as he could discover, no demand for the improvement of Etowah at all, except a contingent one.

Trial Trip of a New Twin Steamer.

The trial trip of the new twin steamer *Express*, which has been built by Messrs. A. Leslie & Company, shipbuilders, Hebburn-on-Tyne, for the Channel Passage Company, for service between Dover and Calais, took place lately. The passage between Dover and Calais is a very turbulent, and therefore an uncomfortable one for passengers; and the question how to make the voyage lighter and steadier, so as to remove as far as possible the discomfort attending it, has often presented itself to nautical minds. Some few years ago Capt. Dicey, the originator of the Channel Company, designed the *Castalia* for this object, and, so far as equability and comfort were concerned, she thoroughly answered her purpose; but her speed was far below that of ordinary steamers, and therefore, although many preferred the more pleasant passage, and chose to take the slower vessel, the majority elected rather to face the storm and have the advantages of the swifter mode of transit. Mr. Leslie, however, undertook to produce a vessel having the qualities required, and the result has been the *Express*. The *Express* was guaranteed to have a draught of not more than seven feet, and to be capable of working at a minimum speed of fourteen knots—the difficulty of this being to get sufficient power into her without immersing her too much in the water, and this Mr. Leslie has accomplished. The draught of the *Express* is about one foot less than the *Castalia*, her length ten feet greater, and she is one foot broader. The two

hulls are each about one foot wider, and the channel between the two ships is slightly narrower in the *Express* than in the *Castalia*; the great difference in construction between the two vessels, so far as the hulls are concerned, however, is, that whereas the *Castalia* is, as it were, two half ships placed a certain distance apart, forming between them a channel, the sides of which are parallel, the *Express* is two complete symmetrical ships, thus making the channel wider towards the ends of the vessel, and narrower towards the paddle wheels. This has the result of giving a more plentiful supply of water to the wheels, and enables them to utilize a much greater proportion of power than with the parallel channel. In the *Express* the two hulls are very rigidly united together by four transverse iron girder bulkheads spanning across the channel. The rudders, of which there are four, one at each end of each ship, act also as bows without any resistance. The vessel is steered by steam, the steering gear being supplied by Messrs. Brotherhood & Hardingham, London. The whole of the passenger accommodation is provided on the superstructure. The saloons are all approached by circular staircases from the upper decks; a large general saloon and a ladies' saloon are forward, and the refreshment saloon and range of state rooms for private families aft. The furnishing is all of the highest order. The vessel accommodates one thousand passengers. The engines, which have been supplied by Messrs. Black, Hawshore & Company, Gateshead, are four thousand indicated horse power. They are diagonal inclined engines, having two cylinders in each ship working on one crank pin. The cylinders are 63 inches in diameter, with six feet stroke and 40 revolutions per minute. There are two patent paddle wheels working independently of each other. The trial trip on Saturday extended along the coast to Coquet Island, a distance from the Tyne of 22½ miles. Amongst the company on board were Mr. Leslie, Captain Dicey, and several engineers and surveyors of the Board of Trade and Lloyd's. The vessel sailed remarkably steadily, and a very pleasant day was spent by the company on board. The runs from Coquet Island back to the Tyne were made a test, and the distance was done in one hour and twenty-two minutes, an average of 14.48 knots per hour. The distance from the Tyne to Coquet is one mile and a half longer than from Dover to Calais. The trial was considered highly satisfactory. The *Express* is expected to commence service soon, and at all events will start in time for the Paris Exhibition.—*London Daily News*.

An anonymous friend of humanity offers a prize of 6,000 francs, to be awarded in 1880, for the most useful application to the healing art of M. Pasteur's discoveries.

REDIER'S NEW REGISTERING THERMOMETER.

M. Redier has devised a new registering thermometer which operates through the dilatation in a straight line of two metals, zinc and steel. If a multiplying mechanism be mounted on a steel bar, 39 inches long, and connected with a zinc bar of the same length, the difference of the two expansions per 212° Fah. will be about .08 inch. This difference is used in the present apparatus to register changes in temperature. Fig. 1 represents the thermometer proper. It consists of an exterior steel tube, A, which carries a toothed wheel, D, on which multiplying mechanism is mounted. Within the tube, A, is a zinc tube, z, which fits closely. These two tubes are connected, and at that point there is a pivot. At the upper portion of tube, z, is a plate, L, on which is fixed a small carriage, Y, which carries a pointer adjustable by the milled head, B. This pointer acts on a pallet, X, which is movable, and which transmits any movement of elongation of the bar, z, to the needle, A. On the extremity of the latter is a small hook, c. The foregoing part of the apparatus is mounted on a plate in face of a double clockwork movement, and so disposed that it turns from right to left, the exterior steel tube, A, serving as a pivot.

The clock train has two springs, M and N. M terminates in a chronometer escapement, and N in a very delicate flier, which turns with great rapidity. These two movements are interconnected by the differential train, R R, S. The satellite, S, entrains the axis, A, which on one side carries the pulley, P, on which is wound a cord which moves the pencil, and on the other a pinion, E, which engages with the wheel, D, Fig. 1, of the thermometer. These two gears are so constructed that the velocity of motor M being 1, that of motor N will be 2.

We may now trace the operation under a constant temperature. The hook, c, of the needle, A, stops the small fly-wheel. The escapement, E, of the motor, M, which works constantly, turns the large wheel, D, from right to left. The needle, A, follows the movement and disengages the flier, V, and spring, N. The latter now being freed, and its velocity being 2, while that of the escapement is 1, tends to turn the wheel, D, from right to left until the needle, A, again catches by its hook, when the same operation is repeated. As the pulley, P, makes the same movement as the wheel, the pencil will trace on paper, if the temperature remains constant, a right line, apparently continuous, but in reality formed of a series of very small zigzags. This movement of constant oscillation is of great importance as regards the sensitiveness of the instrument, as it suppresses the effect of friction at starting, and renders the instrument always ready to show instantly the least change of position of the needle, A. If the temperature augments, the flier, V, remains hooked for a longer or shorter period, proportional to the change of temperature, and as the increase, while turning the wheel, D, from left to right to unhook the flier, also causes the turning of the pulley, P, the latter will rotate over an angle proportionate to that which the change of temperature causes the needle, A, to pass over. The inverse effect is produced when the temperature falls. The pencil, K, Fig. 3, moves on a cylinder, C, on which the paper, H, is rolled. The chronometer, R, regulates the movement of this cylinder at a velocity of 0.16 inch per hour.

A City Sliding Down Hill.

The Virginia (Nev.) *Enterprise* says: "Our town is very quietly moving to the eastward down the face of the mountain. This is owing to the settling of the ground over the Bonanza mines. As all the town is going together it is not much noticed on the surface, where no cracks are seen. The water and gas companies are better acquainted with the movements taking place in the ground forming the site of the town than most others, as the instability of the earth tells upon their pipes.

"On B and C streets, north of Union, the ground is moving both north and east. A water main, running north and south, uncovered yesterday at the cor-

ner of B street and Sutton avenue, was found to be telescoped to the distance of over a foot, and besides had in it a great kink, which made it necessary to take out a piece nearly two feet in length. About the Consolidated Virginia pan mill the pipes are crowding in from both east and west; at least, owing to the settling of the ground in that neighborhood, there appear to be two movements. Although there are as yet no cracks in the central part of the town, there is a large one to the westward. It begins at Cedar Ravine,

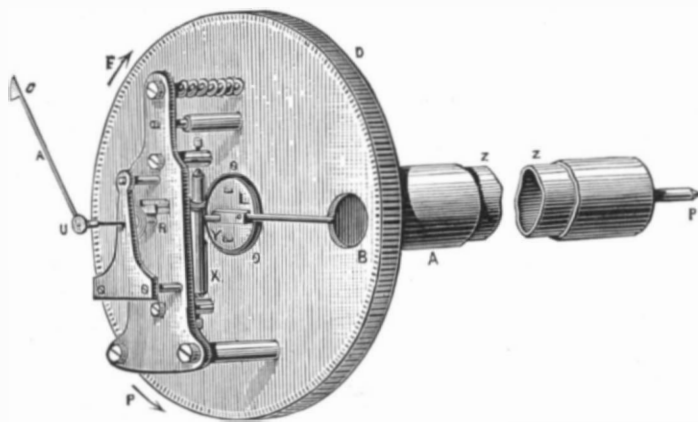

Fig. 1.—REGISTERING THERMOMETER.

runs south to near the large water tank of the Ophir, on the hill west of town, then turns east for a considerable distance, when it takes its course southward west of Stewart street, and finally joins the old crevice below the Gould & Curry croppings. Toward the north this crevice is about eight inches in width, and the ground on the east side of it is about three feet lower than on the west side. Captain Overtown, of the Water Company, whose opportunities for observing these movements are unsurpassed, says that as the ground settles over the bonanzas on the slope of the mountain, where it is not much disturbed, it gradually moves down. He says the International Hotel has moved east about five inches since it was built. If such is the case, all the buildings in that part of the town, with the ground on which they stand, must have moved the same distance, as no cracks are to be seen in the earth. As we are now traveling, however, it will be a long time before we reach the Loaf Sugar."

Salt River, Arizona.

It was long supposed that the brackishness of Salt river, Arizona, was caused by the stream running over a bed of salt somewhere along its course. Its waters are pure and fresh from where it heads in the White mountains to within 50 miles of where it empties into the Gila. Fifty miles from its junction with the Gila there comes into it a stream of water that is intensely salt. This stream pours out of the side of a large mountain, and is from 20 to 30 feet deep. It is very rapid, and pours into the Salt river a great volume of water. Here could be easily manufactured sufficient salt to supply the markets of the world. All that would be necessary would be to dig ditches and lead the brine to basins in the nearest deserts. The heat of the sun would make the salt. Were there a railroad near the stream its waters would doubtless soon be turned and led to immense evaporating ponds. It is supposed that the interior of the mountain, out of which the stream flows, is largely composed of rock salt.

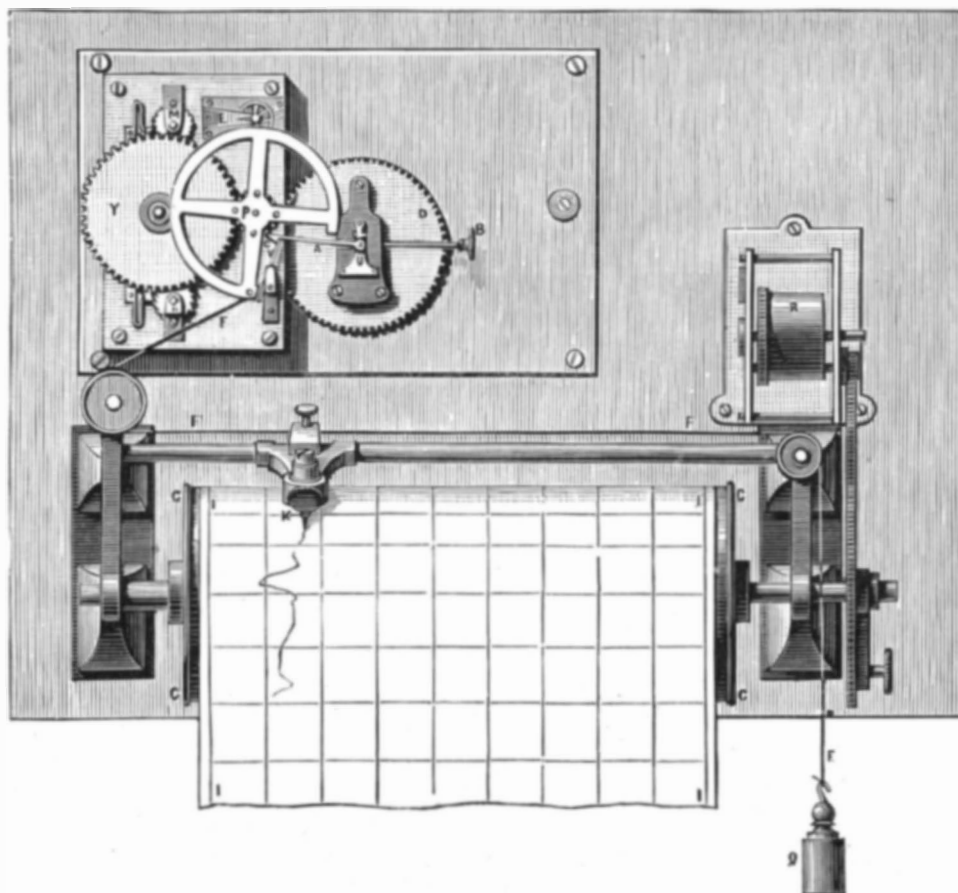

Fig. 3.—REDIER'S NEW REGISTERING THERMOMETER.

Comparative Prices and their Relation to Production.

BY ANDREW J. LAWSON.

In view of the partial settlement of the currency question by the remonetization of silver, coupled with the natural results of the business depression of the past five years, and the laws of supply and demand, perhaps some comparison of prices for the staple agricultural productions may serve as interesting market gossip this week. To begin at the beginning, let us see what the total productions of the leading farm products were five or six years ago, and last year, in order to understand at a glance their relation to the prices that prevailed at that time and now. The wheat product of 1872, both spring and winter, was about 250,000,000 bushels, or about 20,000,000 bushels more than that of 1871, and 37,000,000 bushels less than the crop of 1869, the largest ever produced in the country, excepting that of last year, which was 330,000,000 bushels. The average price of wheat in March, 1872, at Chicago, was \$1.15 per bushel; and of flour, for extra winter wheat, \$7.25 to \$9 per barrel. In 1876 the average value of wheat was \$1.24 per bushel. It is customary to estimate an average of five bushels of wheat for each barrel of flour. With improvements in milling, 4½ bushels would be nearer the truth. Thus, in 1872-73, ground wheat recovered its supremacy from its loss in the previous five years. The best brands of flour are consumed at home, and the bulk of the flour for export consists of that made of the poorer kinds of wheat. However, of late years foreign millers have demanded our best wheat for their own mills. During the past week wheat has advanced slightly, and is quoted at an average of \$1.30 per bushel, considering the various grades. Flour, which was quoted in 1872 at \$6.60 to \$6.75, is now quoted at \$5.90 and \$6.50.

In March, 1872, No. 2 corn was quoted at 37 to 39¼ cents per bushel. The corn crop of the preceding year was reckoned at 1,092,719,000 bushels, valued at \$435,149,290, against \$310,180,000 for the wheat crop. The corn crop of the last statistical year was 1,283,827,500 bushels, valued at \$475,491. The quantity exported in the previous year amounted to 50,910,000 bushels, the largest amount ever exported in a single fiscal year, and nearly 70 per cent greater than the previous year. It must be borne in mind that the exportation of corn, as well as wheat and other cereals, bears an important relation also to the size of the relative crop, as well as home prices. The enormous crop of 1875, which was exported the following year, bore such low prices in the Western markets as to suggest the practicability of a greatly enlarged export trade. From low prices and freights then prevailing, it was calculated that corn could be laid down in the British markets so as to be sold, with a fair margin of profit, at 26 shillings per quarter. The profits of this movement, it may be remembered, somewhat overbalanced its losses. This was one of the causes that has so greatly enlarged the export of corn during the past two years. No. 2 corn is now quoted at from 54 to 55½ cents per bushel, against 37 to 39¼ in 1872.

The rye product of 1872 was 14,048,654 bushels, valued at \$11,363,600, against 20,374,000 bushels last year, valued at \$13,635,000. In 1872, No. 2 rye was quoted at 73 and 74½ cents, against 70 and 75 cents at the present time. The export of this cereal is comparatively slight, and was only one per cent more than in the previous year. In this connection it is a singular fact that in no instance during the last dozen years has its export equaled two per cent of the product. Less than 2,000,000 bushels were sent abroad last year. During the past three years the difference between the averages of its export values has been 49 cents, 11 cents, and 14 cents per bushel, amounting to \$2.48, 56 cents, and 70 cents per barrel. The same causes are doubtless operative in this case as in that of wheat flour and corn meal.

Turning to the subject of meats, we find a gradual but large increase in the packing of pork and the slaughtering of cattle since 1872-73, but prices have varied considerably during the period, influenced more or less by the size of the product and the foreign demand. In 1872 mess pork was quoted, in March of that year, at \$11.95 to \$12.20 per barrel; the rates at the present time are substantially the same. Mess beef, which sold at \$8.75 to \$9, and extra at \$10.75 to \$11, is now quoted at \$10 to \$12.50, and \$14 for the best. The center of the hog and beef trade is at Chicago. There has been a great annual development of the pork-packing business since 1870, and this business is one of the prominent facts in both agricultural and commercial matters. A new feature of the pork business is the great increase of hogs in Texas, which sent to market last year over 2,000,000 head. The production of swine in that section of the country has improved of late years,

the "razor backs" of the past generation having given place to improved breeds. In northern Texas the best strains of Chester White, Essex, Berkshire, etc., are being propagated. In this connection it is noticeable that the immense enlargement of swine products, without any adequate evidence of equivalent decrease in the rate of home consumption, has only been accomplished by increase of average weight, or large increase of numbers in proportion to population.

A comparison of prices for 1876 with the present time shows the following, so far as the Boston market is concerned: Ham, superfine, spring, \$4 to \$4.25; good to fancy, \$6 to \$9. March, 1878, \$4.25 to \$4.75; good to fancy, \$6.50 to \$8. Pork, two years ago, that sold at \$22.65 to \$22.80, and \$18.50 to \$21.50, is now sold at \$10 to \$10.50, and \$12 to \$14 per barrel.

In the matter of dairy products, there is little or no difference in the prices that prevailed six years ago and now. Then New York and Vermont butter was quoted in March at 18 to 35 cents; cheese was a few cents higher, ranging from 14½ to 17½, against 12 and 14½ cents at the present time; while two years ago prices for these articles were a cent or two higher than the prevailing rates. Lard is now selling at 7½ to 8 cents, against 13 to 13½ cents in 1876, and 9¼ to 10 cents in 1872. The article of hay, of which there were produced in 1872 23,969,000 tons, valued at \$348,000,000, sold in that year in Boston, in March, from \$22 to \$32 for Northern and Eastern, and \$25 to \$30 for Western choice. The quotations now stand at \$20 for fancy Northern, and \$16 and \$19 for other kinds. Two years ago Eastern and Northern hay was cheaper than it now is, having sold at from \$13 to \$20 per ton. The hay crop of 1876 was estimated at 30,867,000 tons, valued at \$300,000,000. The crop of 1872 was estimated at 23,000,000 tons, valued at \$345,000,000.

This subject of comparative prices might be pursued to an almost indefinite extent. Potatoes, for instance, the crop of which, six years ago, was 113,516,000 bushels, grown on 1,331,000 acres, and valued at \$68,000,000, were sold in that year at the rate of 90 to 95 cents per bushel for Early Rose, and the same for Jackson Whites. The crop of last year was estimated at 124,000,000 bushels, grown on 1,741,000 acres, valued at \$83,000,000, while the prevailing prices range from 35 to 60 cents, according to quality. The average value per acre of the crop six years ago was \$51.14, last year \$48.14, the average price per bushel being 65½ cents.

The apple crop has also varied a good deal, both in the quantities raised, the export demand, and the prices obtained. Although this is a national fruit, and has become an important article of export, yet the Government statistician has furnished no good data of facts respecting the trade in this article. Respecting jobbing prices, however, it appears that in 1872 prices for a good article ranged from \$2.50 to \$3 for Western, and \$2 to \$2.50 for Eastern, as against \$4.25 and \$5 per barrel at the present time.

Not omitting some of the more material products that enter into the manufacture of textile goods, the ups and downs of the wool market afford a good study. In 1872 the range of prices was as follows: Picklock XXX Ohio and Pennsylvania, 57 to 85 cents per pound; medium XX Ohio and Pennsylvania, 56 to 85 cents; Michigan, 52 to 82 cents; Western, 50 to 82 cents. In 1876 (at this season of the year) prices ranged from 38 to 52½ cents for Ohio and Pennsylvania, 42 to 46 for Michigan, 35 to 47 for pulled, 42 to 65 for combing fleece, and 14 to 33 cents for California. Present quotations: Ohio and Pennsylvania, 42 to 43 cents for medium; Michigan, Wisconsin, etc., range from 38 to 40 cents; and low and coarse fleeces from 34 to 37 cents per pound; combing and delaine are nominal. The wool market is very dull at the present time.

Respecting the future prices for farm products the matter is enigmatical, but the hope is that a business revival may soon come and advance and strengthen prices for all kinds of produce, and thus enable the farmer to realize a fair profit and a good market.—*Boston Cultivator.*

What Kills.

In the school, as in the world, far more rust out than wear out. Study is most tedious and wearisome to those who study least. Drones always have the toughest time. Grumblers make poor scholars, and their lessons are uniformly "hard" and "too long." The time and thought expended in shirking would be ample to master their tasks. Sloth, gormandizing, and worry kill their thousands, where over-study harms one. The curse of Heaven rests on laziness and gluttony. By the very constitution of our being they are fitted to beget that torpor and despondency which chill the blood, deaden the nerves, enfeeble the muscles, and derange the whole vital machinery. Fretting, fidgeting, ennui, and anxiety are among the most common causes of disease. On the other hand, high aspiration and enthusiasm help digestion and respiration, and send an increased supply of vital energy to all parts of the body. Courage and work invigorate the whole system, and lift one into a purer atmosphere, above the reach of contagion. The lazy groan most over their "arduous duties," while earnest workers talk little about the exhausting labors of their profession. Of all creatures, the sloth would seem to be the most worried and worn.—*B. G. Northrop, Conn.*

The cabin fittings of the new Cunard steamer Gallia are being made in Japan. It is stated that the work will be cheaper and better than if made in England.

THE PHILADELPHIA LAWN MOWERS.

We illustrate herewith two forms of an improved lawn mower, which is claimed to run easily, work efficiently, and to be strongly and durably constructed. Fig. 1 represents the 6½ inch driving wheel machine, of which five sizes are made, suitable for large and small lawns. The construction will be readily understood from the engraving. Fig. 2 is a new 15 inch mower, with 8½ inch driving wheels, and 6½ inch wiper or revolving knife cylinder. It weighs 51 lbs.,

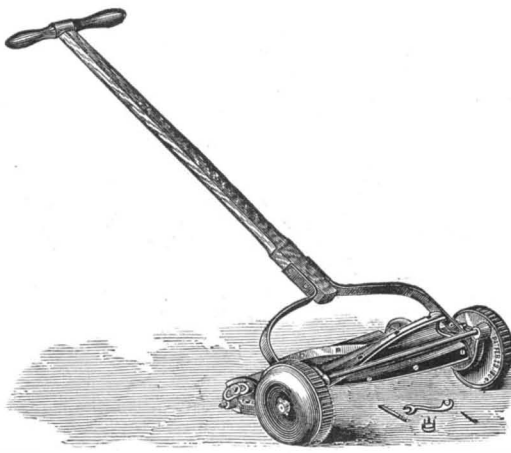

THE PHILADELPHIA LAWN MOWER.—Fig. 1.

runs light for one man, and can be adjusted to cut from ½ to 1½ inch high. For large open lawns this mower is especially well suited.

An excellent feature of these machines is that they are self-sharpening; and all wear of the wiper journals can be taken up by set screws. The weight of the 6½ inch mowers ranges from 32 lbs. to 50 lbs. Large mowers adapted to be

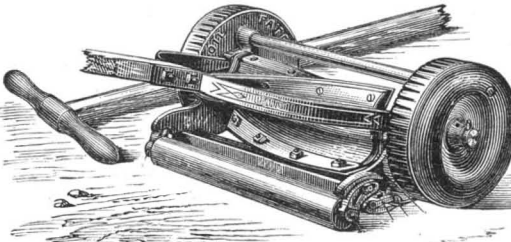

THE PHILADELPHIA LAWN MOWER.—Fig. 2.

drawn by a horse range from 315 to 450 lbs. For further information address the manufacturers, Messrs. Graham, Emlen & Passmore, 631 Market St., Philadelphia, Pa.

THE HORN BUG.

BY PROFESSOR C. V. RILEY.

One of the most common and most interesting American beetles met with at this season of the year in wooded regions is what is popularly called the "horn bug," and entomologically known as *Passalus cornutus*, Fabr. Few insects are more familiar to the Western farmer's boy, who finds it in every old stump or under every old log that he digs into or turns over. The polished, rather elegant creature, with its slow, clumsy motions, makes a very good plaything for little folk, who are fond of causing it to draw diminutive objects hitched by means of a thread to the curved horn on its head. How few of them, however, ever interest themselves in its development, or ask themselves where it comes from and how it grows! When disturbed, this beetle makes known its displeasure by a peculiar half squeaking, half hissing sound, produced by the friction of the horny terminal joints of the abdomen against the inside of the hard wing covers.

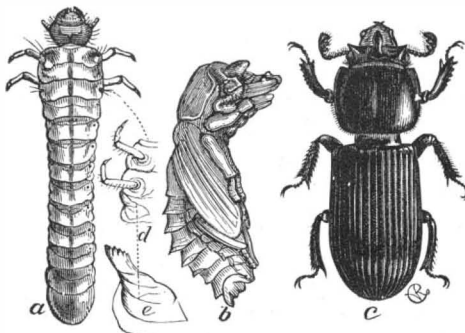

Passalus Cornutus.—a, larva; b, pupa; c, beetle; d, sternum, showing atrophied third leg; e, this last enlarged.

Common as is the beetle, its larva and pupa are but seldom met with, and the natural history of the species was first published in the fourth and fifth Reports on the Insects of Missouri. The eggs are deposited under the loose bark of decaying logs, are ovoid, and 0.12 inch long. The shell is smooth, flexible, but tough, and of various shades of olive green. The eggs hatch in July, and the larva acquires full growth in the amazingly short period of six weeks. The larva is very exceptional, in that it possesses but two pairs of well developed thoracic legs, the third pair being so rudimentary as to be almost invisible. The form is, in other respects, grub-like, the thoracic joints being slightly enlarged and flattened.

The color is bluish white, except the head, which is a light

rust brown. It transforms in the autumn, within the decaying wood upon which it feeds, to a bluish white pupa, in which the front pair of legs of the future beetle are thrown forward under the head, and the horns are plainly visible on top. It remains in the pupa state only about two weeks.

ASTRONOMICAL NOTES.

BY BERLIN H. WRIGHT.

PENN YAN, N. Y., Saturday, April 20, 1878.

The following calculations are adapted to the latitude of New York city, and are expressed in true or clock time, being for the date given in the caption when not otherwise stated.

PLANETS.

	H.M.		H.M.
Mercury sets	8 22 eve.	Saturn rises	4 10 mo.
Venus rises	8 27 mo.	Uranus in meridian	7 56 eve.
Mars sets	10 53 eve.	Uranus sets	2 48 mo.
Jupiter rises	1 42 mo.	Neptune sets	7 09 eve.

FIRST MAGNITUDE STARS.

	H.M.		H.M.
Antares rises	10 05 eve.	Sirius sets	9 44 eve.
Regulus in meridian	8 06 eve.	Procyon sets	11 56 eve.
Spica rises	6 00 eve.	Aldebaran sets	9 3 le. w.
Arcturus in meridian	0 17 mo.	Algol (2d-4th mag. var.) sets	10 15 eve.
Altair rises	11 19 eve.	Capella sets	1 24 mo.
Vega rises	7 43 eve.	7 stars (cluster) sets	9 34 mo.
Deneb rises	8 46 eve.	Betelgeuse sets	10 18 eve.
Alpheratz rises	2 18 mo.	Rigel sets	8 43 eve.

REMARKS.

Venus, Jupiter, and Saturn are now morning stars. Mercury and Mars are evening stars. Mercury sets 1h. 38m. after the sun, and just as twilight ends, the sun at that time being 18° below the horizon. He is stationary April 26. Jupiter will be morning star after April 25; is occulted by the moon April 24 in the morning. This rare phenomenon is only visible south of 20° south latitude. Their nearest approach in this latitude is at 6h. 25m. morning, at which time Jupiter is about 38' north of the moon. As twilight begins at 3h. 29m. morning, perhaps 4 o'clock in the morning will be the best time to observe them, at which time their relative positions will vary but little from those given above. Jupiter is at his western quadrature April 25.

New Mechanical Inventions.

Mr. T. H. Thompson, of Benson, Minn., has invented a Trace Trimming and Creasing Machine, which trims, edges, creases, and smooths harness traces in a single operation, by means of a combination of adjustable rollers and cutters.

Mr. F. E. Brandis, of Brooklyn, N. Y., has invented a Spindle Attachment for Surveyors' Instruments, by which the upper cone on the parallel rods of the tripod is done away with, the vertical distance between the center of the ball and socket joint and the bubble is reduced, and the biasing of the center by the parallel screws dispensed with.

An improvement in Safe Bolt Works has been devised by Mr. Mayer Adler, of New York city. In this arrangement vertical sliding and lateral swinging bolts are jointly operated by coupled pivot rods of the lock, which are extended beyond the lock or drawn back by a key socket and cam, actuated by a lug on the key.

A Balanced Slide Valve, invented by Mr. R. G. Bishop, of Chetopah, Kan., is claimed to be not liable to leak or wear out. A center chest cast on the cylinder is connected with side chests. At both ends of the center chest are lateral chambers, opening by ports into the cylinder, for inducting and educting the steam, the lateral ports opening also side-wise into the side chests, in which two slide valves, connected by transverse screw bolts, are reciprocated.

An improved Horse Power, patented by Mr. Squire Thomas, of Junction City, Oregon, consists of a wheel placed in a movable frame and arranged to roll upon the ground, and in a stationary frame containing gearing driven by the traveling wheel, as it is drawn around it by the horses.

Mr. Norman Bly, of Crown Point, N. Y., has invented an improved machine for Reducing Wood to Paper Pulp. It consists of a series of thick circular saws and a single thin guide saw of slightly larger diameter, mounted on a mandrel or shaft and driven by a suitable motor.

An improved Lifting Jack has been invented by Mr. J. B. Fayette, of Oswego, N. Y. It combines two essential points, the application of power in a direct line with the slides, thus obviating side strain, and lifting the object the full throw of the machine.

Mr. G. B. Markle, of Jeddo, Pa., has invented a machine for Breaking Coal and similar substances. The breaker plates are each made in two parts, dovetailed together, to enable the inner toothed parts to be readily removed. Power is applied by eccentric arms from the shaft to one of the plates, which is rearwardly inclined, and the other plate is adjustable, by means of set screws, so as to regulate the fineness to which the coal is broken.

Mr. J. A. Morrison, of Karns City, Pa., has patented a combined Elevator and Clamp for the Sucker Rods of Oil Wells, intended to dispense with the use of sucker rod wrenches, to retain the rods steadily in position, and protect their threaded ends. It consists of a main lever, forked at its lower end, and having a clamp recessed to receive the shoulder or neck of the rod, which clamp is fulcrumed in the fork. A safety slide is guided along the shank of the main lever, and may be lowered over the threaded portion of the rod to protect and secure it.

A new form of Windmill, invented by Mr. G. B. Dean, of Lamoille, Ill., is constructed almost entirely of iron, with the exception of the wheel and vane, and so as to dispense with the use of heavy and complicated turn tables, oil boxes, and joints.

Business and Personal.

The Charge for Insertion under this head is One Dollar a line for each insertion; about eight words to a line.

Drawings and Engravings of Machinery a specialty. Pemberton & Scott draughtsmen, 37 Park Row, Room 30. Vertical Scientific Grain Mills. A. W. Straub & Co., Phila.

Assays of Ores, Analyses of Minerals, Waters, Commercial Articles, etc. Technical formulae and processes. Laboratory, 33 Park Row, N. Y. Fuller & Stillman.

Best Wood Cutting Machinery of the latest improved kinds, eminently superior, manufactured by Bentel, Magedant & Co., Hamilton, Ohio.

\$10,000.—A manufacturing company having room and power to spare, desire to find some additional staple article to make affording good profit, and that can be extended into a large business. Part of the necessary capital furnished if desired. Address P. O. Drawer 417, Bridgeport, Conn.

For Best Insulated Telegraph Wire, Telephone Wire, and Flexible Cordage. Eugene F. Phillips, 67 Stewart St., Providence. R. I. W. H. Sawyer, Electrician and Supt.

Dead Pulleys, that stop the running of Loose Pulleys and Belts, taking the strain from Line Shaft when Machine is not in use. Taper Sleeve Pulley Works, Erie, Pa. Water Wheels, increased power. O. J. Bollinger, York, Pa.

For State Rights to Manufacture or Sell the Automatic Self-feeding Oil Cook Stove, Patented Dec. 25, 1877. Address J. D. Lane, 167 Reade St., N. Y. city.

Latest and best Books on Steam Engineering. Send stamp for catalogue. F. Keppy, Bridgeport, Conn.

For Sale.—Whole interest, caveat secured. Machine grinds thread tools any pitch and angle. Box 1801, Denver, Colorado.

Corniss Engine Builders, with Wetherill's improvements. Engineers, Machinists, Iron Founders, and Boiler Makers. Robt. Wetherill & Co., Chester, Pa.

Best Launches, Launch and Stationary Engines, second Hand Iron Tools and Saw Mills. S. E. Harthan, Worcester, Mass.

24 inch Second-hand Planer, and 12 inch Jointer, or Buzz Planer, both in first-class order, for sale by Bentel, Magedant & Co., Hamilton, Ohio.

For Town and Village use, comb'd Hand Fire Engine & Hose Carriage, \$350. Forsaith & Co., Manchester, N. H.

Wrenches.—The Lipsey "Reliable" is strongest and best. Six inch sample by mail 60 cents. Roper Caloric Engine Manufacturing Co., 91 Washington St., N. Y.

Agents wanted in every county to sell our new Machine to file all kinds of Saws. Every one that uses a Saw will buy one. Price \$2.50. Illustrated Circulars, etc., free. E. Roth & Bro., New Oxford, Pa.

Carriage Axles, Springs, Bolts. Wanted full particulars and prices of machines used in the manufacture of above. Address Selby & Co., Longmore St., Birmingham, England.

For Sale.—A rare opportunity to secure Shop or State Rights, or the entire patent, for the best Balance Valve, with automatic cut-off regulator for portable and stationary engines; no experiment; hundreds of them in use giving good satisfaction. H., Carrier No. 4, Detroit, Mich.

Cornice Brakes, J. M. Robinson & Co., Cincinnati, O.

Blake's Belt Studs, best fastening for Rubber and Leather Belts. Greene, Tweed & Co., 18 Park Place, N. Y.

Friction Clutches warranted to drive Circular Log Saws direct on the arbor, and Upright Mill Spindles, which can be stopped instantly; Safety Elevators, and Hoisting Machinery. D. Frisbie & Co., New Haven, Ct.

Union Eyelet Company, Providence, R. I., Manufacturers of Patented Novelty on royalty.

Bolt Forging Machine & Power Hammers a specialty. Send for circulars. Forsaith & Co., Manchester, N. H.

The Cameron Steam Pump mounted in Phosphor Bronze is an indestructible machine. See ad. back page. Sperm Oil, Pure. Wm. F. Nye, New Bedford, Mass.

For Solid Wrought Iron Beams, etc., see advertisement. Address Union Iron Mills, Pittsburgh, Pa., for lithograph, etc.

John T. Noye & Son, Buffalo, N. Y., are Manufacturers of Burr Mill Stones and Flour Mill Machinery of all kinds, and dealers in Dufour & Co.'s Bolting Cloth. Send for large illustrated catalogue.

Power & Foot Presses, Ferracute Co., Bridgeton, N. J.

Solid Emery Vulcanite Wheels—The Solid Original Emery Wheel—other kinds imitations and inferior. Caution.—Our name is stamped in full on all our best Standard Belting, Packing, and Hose. Buy that only. The best is the cheapest. New York Belting and Packing Company, 37 and 38 Park Row, N. Y.

1,000 2d hand machines for sale. Send stamp for descriptive price list. Forsaith & Co., Manchester, N. H.

Steel Castings from one lb. to five thousand lbs. Invaluable for strength and durability. Circulars free. Pittsburgh Steel Casting Co., Pittsburgh, Pa.

For Best Presses, Dies, and Fruit Can Tools, Bliss & Williams, cor. of Plymouth and Jay Sts., Brooklyn, N. Y.

Hydraulic Presses and Jacks, new and second hand. Lathes and Machinery for Polishing and Buffing metals. E. Lyon & Co., 470 Grand St., N. Y.

Safety Linen Hose. Suction and Rubber Hose of all kinds. Greene, Tweed & Co., 18 Park Place, N. Y.

For Boul's Paneling, Moulding, and Dovetailing Machine, and other wood-working machinery, address B. C. Machinery Co., Battle Creek, Mich.

Patent Scroll and Band Saws. Best and cheapest in use. Cordesman, Egan & Co., Cincinnati, O.

Chester Steel Castings Co. make castings for heavy gearing, and Hydraulic Cylinders where great strength is required. See their advertisement, page 254.

Diamond Drills, J. Dickinson, 64 Nassau St., N. Y.

Lansdell's Steam Siphon pumps sandy and gritty water as easily as clean. Leng & Ogden, 212 Pearl St., N. Y.

Hand Fire Engines, Lift and Force Pumps for fire and all other purposes. Address Rumsey & Co., Seneca Falls, N. Y., U. S. A.

The Turbine Wheel made by Risdon & Co., Mt. Holly, N. J., gave the best results at Centennial test.

Vertical & Yacht Engines. N. W. Twiss, New Haven, Ct.

Talley's Hydraulic Engine (see description and cut March 9, 1878), as a simple, cheap, effective and economical power, is unsurpassed, and is meeting with great success. Economy Hydraulic Engine Co., Kansas City, Mo.

Notes & Queries

E. T. M.—The sample of insulated wire sent is rather coarse, but it will answer for the purpose.

J. J. B.—It appears to us that your best course is to seek some position in a telegraph office, in which you will be apt to receive a thorough practical education in the art.—D. W. D.—See p. 165, SCIENTIFIC AMERICAN, No. 11, vol. 35; and p. 229, No. 15, vol. 35. By arranging the slide valve to cut off at about three quarter stroke, the proposed engine would probably answer.—G. D. B.

Gas carbon may be cut into plates by means of a common hand saw.—J. A.—See answer No. 42, p. 396, SCIENTIFIC AMERICAN, December 22, 1877.—F. J. S.—There are a number of treatises on the subject, in addition to the more complete arithmetics, which you should consult as the discussion would be too extended for these columns.—J. H. H.—You can probably obtain this information by inserting a notice in the "Business and Personal" column, which is especially intended for such inquiries.—T. Mf. Co.—You will find a *résumé* of the subject of spontaneous ignition in Bird's "Protection against Fire," pp. 122-137.—E. C. N.—The word "cover" should read "core."—C. H. L.—See answer No. 18, SCIENTIFIC AMERICAN, April 13, 1878.—F. W. S.—The sample of sheet iron inclosed is rather heavy for a telephone diaphragm, but it will answer.—D. B. T.—Consult any elementary astronomy. The discussion would occupy more space than we have at command.—M. V. D.—Perhaps if you will apply to a commission merchant doing this kind of business you may obtain particulars.—D. G.—We do not get a very clear idea of the arrangement from your letter; but if, as we understand, you are trying to overcome what some call the loss of power by the use of the crank, our advice would be to stop trying, as there is no such loss as supposed.—J. F.

—The result is certainly unusually good, if there is any proof that the steam was dry.—E. H. L.—You do not send sufficient data about the engine. The flues will answer for boilers if in good order. They can be set in brick, like ordinary cylinder boilers. It might be better to connect one to the other than to set them side by side.—C. E. C.—The details sent are not sufficient. You will find rules in Trautwine's "Engineer's Pocket Book," which will enable you to solve the problem.—W. F. A.—You can make a boiler of copper $\frac{3}{4}$ inch thickness, 4 inches in diameter, and 12 inches long, with rounded heads. You can obtain information as to cost from a coppersmith.—W. J. P.—From the data sent we are unable to explain the matter.—L. G.—See answer to A. B. P., this page.—T. J. F.—You cannot make such an alloy. For mode of boring gun barrels see SUPPLEMENT, No. 25, p. 387.—G. L. D. & Co.—See answer to F. H. T., next page.—R. S. L.—For description of the telephone see SCIENTIFIC AMERICAN, No. 14, vol. 37. The ordinary telegraph wire is the only connection required. See answers Nos. 15, 19, and 22, p. 155, March 9, 1878. The general principle is not patented.—C. C. S.—The only way which occurs to us is to add fillings of metal to the plaster.—C. S.—The word "subornation" does not necessarily mean to cause a person to commit perjury, but in its broad sense "the crime of procuring one to do a criminal or bad action" (Webster), and therefore the phrase "subornation of perjury" is not tautological.

(1) G. H. A. writes: I have a small galvanic battery, the zinc of which is broken. Would the same metal answer, if melted and moulded over again? A. Yes.

(2) L. W. C. asks for a recipe for preparing a gold (or bronze) ink that will flow from a ruling pen and leave a bright clear line. A. Honey and gold leaf, equal parts; triturate until the gold is reduced to the finest possible state of division, agitate with 30 parts of hot water and allow to settle. Decant the water and repeat the washing several times; finally dry the gold, and mix it with a little weak gum water for use.

(3) A. H. L., referring to the article in the SCIENTIFIC AMERICAN of March 30, p. 197, relative to the need of efficient means of destroying dangerous wild beasts, as in India, suggests that placing poisoned meats in the habitats of such animals would be a speedy and cheap means of exterminating them, and more effective than hunting them down.

(4) G. J. S. asks for recipes for making copying, black, and red inks. A. 1. Bruised Aleppo nutgalls, 2 lbs.; water, 1 gallon; boil in a copper vessel for an hour, adding water to make up for that lost by evaporation; strain and again boil the galls with a gallon of water and strain; mix the liquors, and add immediately 10 ozs. of copperas in coarse powder and 8 ozs. of gum arabic; agitate until solution of these latter is effected, add a few drops of solution of potassium permanganate, strain through a piece of hair cloth, and after permitting to settle, bottle. The addition of a little extract of logwood will render the ink blacker when first written with. Half an ounce of sugar to the gallon will render it a good copying ink.

2. Shellac, 4 ozs.; borax, 2 ozs.; water, 1 quart; boil till dissolved, and add 2 ozs. of gum arabic dissolved in a little hot water; boil and add enough of a well triturated mixture of equal parts indigo and lampblack to produce the proper color; after standing several hours draw off and bottle.

3. Half a drachm of powdered drop lake and 18 grains of powdered gum arabic dissolved in 3 ozs. of ammonia water constitute one of the finest red or carmine inks.

(5) C. C. B. asks: What should gold fish eat? I have kept two gold fish for several months in a small glass aquarium, changing the water only once a week, and have not fed them anything. They seem perfectly well and lively. A. In a natural state they live principally on animalculæ. It is best to feed them very seldom, and they are sometimes kept without feeding at all. A little bread or cracker is as good as anything.

1. Does a locomotive drawing an ordinary passenger train use as much power in running 20 miles an hour against a head or quartering wind—blowing at the rate

of 20 miles an hour—as one running 40 miles an hour with no wind, other things equal? A. We think not. 2. Which would offer the most resistance, a head or quartering wind? A. A quartering wind, nautically speaking, is one abaft the beam; but, as we understand the question, a wind not quite ahead would probably cause greater retardation than one directly head, owing to the friction caused by the jamming of the wheel flanges against the lee rail.

(6) J. I. asks: Is there any other substance which can be used in place of lime in the oxyhydrogen lights? A. Magnesia alone and with lime—as from dolomite—has been used, but lime is preferable as it is much harder and as refractory.

(7) A. B. P. asks: 1. Will common flower-pots serve as porous cups in a battery? A. Yes; moderately well. 2. Is a two-cell Daniell a good battery for electro-plating? A. Yes.

How can I make sulphocyanide of mercury? A. To solution of potassium or ammonium sulphocyanate (sometimes called sulphocyanide) add solution of mercuric nitrate; mercuric sulphocyanate is precipitated as a white powder. This, thoroughly washed, formed into little cones and dried, constitutes the toys called Pharaoh's serpents.

(8) G. F. M. asks how to make ferric oxalate in small quantity. A. Add a small quantity of neutral potassic oxalate to solution of a ferric salt (ferric chloride answers); the yellow precipitate is ferric oxalate. The same salt is formed by treating ferric hydrate with a quantity of strong oxalic acid solution just insufficient to dissolve it. It is almost insoluble in water; its solution in oxalic acid soon reverts to ferrous oxalate under exposure to sunlight.

(9) W. D. asks: What is ozone and what are its properties? A. There has been considerable discussion about the nature and composition of ozone; but the most trustworthy experiments seem to show that, in whatever way produced, it is merely a modified form of oxygen. Ozone is insoluble in water and in solutions of acids or alkalies, but is absorbed by a solution of potassium iodide. It is decomposed by heat, gradually at 100° C., instantly at 290° C. It is an extremely powerful oxidizing agent, possesses strong bleaching and disinfecting powers, corrodes cork, caoutchouc, and other organic substances, and rapidly oxidizes iron, copper, and even silver when moist, as well as dry mercury and iodine.

(10) F. R. McG. asks how to make an aquarium watertight. A. A good cement is composed of 3 ozs. of linseed oil, 4 ozs. of tar, and 1 lb. of resin. These are allowed to melt together over a gentle fire. If too much oil is used, the cement will run down the angles of the aquarium; to obviate this, it should be tested before using by allowing a small quantity to cool under cold water, and if not found sufficiently firm, allowing to simmer longer, or have more tar and resin added. The cement should be poured in the angles of the aquarium while in a liquid state, but not when boiling, or it would most assuredly crack the glass. The cement will become firm in a few minutes, and the aquarium may then be tilted up in a different position while a second angle is treated likewise. This composition adheres firmly to the glass, is so pliant that it may be pressed into any shape by the fingers, and it does not communicate any poisonous quality to the water.

(11) J. C. E. writes: When an electric current is passed through water decomposition takes place. Is there any liquid which will conduct electricity (with great or little resistance) without decomposition? A. Mercury.

(12) A. B. asks for a cement to join leather. A. Ten parts of carbon disulphide and one part oil of turpentine are mixed, and as much gutta percha added as will readily dissolve. The surfaces of leather must be freed, with a hot iron, from grease or oil, and the parts once joined should be well pressed until they are firmly united.

(13) J. P. S. asks: 1. What can I melt or mix with asphaltum to make it tough enough for water pipes for use on my farm? A. Fine sand, lime, and straw or other vegetable fiber have been used in this connection. 2. In digging a well I struck a vein of gas 15 feet beneath the surface. If I bore down 50 or 60 feet further, will the flow of gas be likely to increase? A. It is uncertain. 3. Is there any danger of my losing it by boring? A. No. 4. Can it be used to advantage for lighting a dwelling, and also for fuel? A. You will find a reference to this subject on p. 52, present volume of the SCIENTIFIC AMERICAN. 5. Close by the well are a number of asphaltum springs. Are the asphaltum and gas an indication of petroleum? A. Not necessarily.

(14) A. M. H. asks: 1. Does prepared sulphate of nickel and ammonia need the addition of cyanide or anything else to make the bath for nickel plating efficient? A. No. 2. Can brass articles freshly turned and perfectly cleaned be nickel plated without first copper plating them? A. Yes; better pickle them in dilute acid first. 3. In gilding watch cases, is it first necessary to copper plate them, no matter what the metal may be? A. No. 4. Please tell me how the inclosed pieces of plating are done. A. The pieces appear to have been electro-plated. Consult Napier's "Manual of Electro-Metallurgy."

(15) E. J. R. asks: 1. What cement is used in mending rubber shoes? A. Incorporate by fusion equal parts of gutta percha and genuine asphaltum; use warm. 2. What will mend china and glassware so as to stand ordinary dish-washing? A. 1. Isinglass dissolved in spirits of wine to a thick paste, 2 ozs.; pale gum-ammoniac (in tears), 10 grains; triturate together until solution is complete. Then add six large tears of gum mastic dissolved in the least possible quantity (over a water bath) of rectified spirit. 2. Boil 4 ozs. of shellac and 1 oz. of borax in water till dissolved; concentrate to a paste by heat.

(16) G. D. asks: How are the hypophosphites of iron and soda made? A. Hypophosphite of soda is formed by boiling a grain or two of phosphorus, a few grains of sodic hydrate, and about a quarter of an

ounce of water until phosphureted hydrogen (spontaneously inflammable) ceases to be evolved. The mixture filtered, yields solution of hypophosphite of soda. Care must be taken against explosion. Hypophosphite of iron is formed by dissolving ferric hydrate in cold aqueous hypophosphorous acid, and evaporating the solution.

(17) G. D. asks whether dynamite is as "harmless as putty," and whether there are any well authenticated cases of its exploding in an unexplained manner. A. Dynamite, as it is now made, is recognized as among the safest of all explosives. It would be absurd to call it as harmless as putty, but, when handled carefully, there is slight danger. When ignited in the open air it burns quietly, and neither light, electricity, nor ordinary shocks cause it to explode. The chief dangers are in connection with the fulminates used to explode it, and in the possibility of the exudation of nitro-glycerin from careless manufacture or as a result of thawing after freezing. However, although dynamite in its various forms is used extensively in mining, we know of no recent accidents in which the same was not directly traceable to carelessness; and not long ago, during a fire in San Francisco, a large quantity was burned without explosion.

(18) B. W. S. asks: How can I remove ink stains from a book cover, common cloth binding? A. Try a weak solution of oxalic acid; dry with warm blotting paper or pipe clay.

(19) H. L. B. asks: What is the best and cheapest way of polishing a hard wood floor? A. After it has been planed as smooth as possible, rub down with sand paper, and then oil.

(20) P. L. W. asks: How do scientists prove that ether (which conducts light and heat from the sun) is imponderable? Or what reason do they have for believing that it is? A. The existence of the ether is assumed to account for various phenomena, but has not been proved by any physical tests. "Energy cannot exist except in connection with some material substance," says Dr. Maxwell. Hence, since in the space between the earth and sun, the luminous and thermal radiations possess energy, the amount of which can be measured, this energy must belong to matter existing in the interplanetary spaces. By imponderability is meant, not absolute absence of weight, but want of appreciable density, as is shown by the fact that the ether does not sensibly retard planetary motions.

(21) D. E. J. asks: How can I make a mirror? A. It is more advisable to purchase one already made, but you may proceed as follows: On a perfectly level, smooth piece of marble, spread a piece of pure tinfoil, smoothing out every wrinkle and crease. Pour a little clean mercury on the foil, and spread it quickly and uniformly by means of a roller of woolen stuff; then pour mercury in the middle until the foil is covered to a depth of $\frac{1}{8}$ of an inch, and slide the glass plate (previously thoroughly cleaned and dried) on the table in such a manner as to carry off the supernatant mercury. Place a weight on the glass, and slightly tip the table to allow the excess of mercury to run off. The plate must then be covered with thick cloths and heavily weighted for several days.

(22) W. T. R. asks: How can the scraps of waste leather produced in the manufacture of boots and shoes be utilized? A. Chips, parings, etc., of shoe leather having the grain on are about valueless; they are sometimes mixed with superphosphates for fertilizing purposes. Leather shavings free from grain can be used in glue manufacture or made into so-called leather board or pancake leather, used for brush backs, inner soles, heels of shoes, etc. These shavings bring in the market from \$15 to \$20 a ton, dry.

(23) T. T. R. asks: What will cause the wrought iron arms of a light cast iron pulley wheel to adhere and prevent it from blowing or casting hollow? A. Dry the moulds and heat the arms before running the metal.

(24) P. B. C. asks: Is there any rule for setting the valves on locomotives while on the road, without taking the chest cover off? A. They can be set by trial, opening the cylinder cocks, and turning the wheels, so as to move the piston. Or the valve stem, shaft, or eccentric may be marked in the shop, so that the adjustment can readily be made.

(25) J. R. S. asks: Is a two-bladed propeller 30 inches in diameter, 44 inches pitch, run at 300 revolutions, likely to do as good work with a boat 30 feet long as one of 3 or 4 blades, same diameter and pitch? Which will shake the boat most? A. The three bladed propeller gives steadier motion, and is usually more efficient than the one with two blades.

(26) W. S. N. asks: What is meant by a miner's inch? A. The miner's inch is the amount of water flowing in one second from an orifice 1 inch x 1 inch, under a head of 6 inches, measured from the upper side of the orifice.

(27) B. W. writes: After one melting, silver works very easily under the hammer; after re-melting two or three times it becomes quite brittle and cracks when hammered. What are the cause and the remedy? I melt in sand crucibles with a little borax. A. It probably requires to be annealed.

(28) C. M. B. asks: Is there any way to prepare vulcanite set squares, etc., so that they will not soil the drawing paper, without altering the exactness of the squares? A. Clean them frequently with a little pure benzole and chamois skin.

(29) P. C. asks: What is the cause of the cracking of marble, as seen in the monuments in our cemeteries? The same thing is not observable, at least to an equal extent, in the blocks used in building. A. It is usually due to the action of frost and storms. The monuments are ordinarily more exposed than the stones of buildings.

(30) H. S. T. asks how the common nickel salts are formed. A. Chloride of nickel is formed by dissolving metallic nickel or its oxide in hot hydrochloric acid and evaporating the solution (after filtering) to complete dryness, redissolving the residue in

water and crystallizing out the salt by evaporating the solution at a gentle heat. The sulphate of nickel is prepared from the oxide in a similar manner, using hot dilute sulphuric acid in place of hydrochloric. For the double sulphate of nickel and ammonia, dissolve four parts sulphate of nickel in a small quantity of hot water and add two parts of aqua ammonia; crystallize the solution by evaporation.

(31) P. H. asks: Does frost have a tendency to make steel brittle? A. Dr. Styffe comes to the conclusion that the absolute strength of steel is not diminished by cold, but that the elasticity is, and therefore steel at low temperatures, when subjected to a sudden blow, is more apt to crack. Consult Sandberg's experiments, described in the American Cyclopædia, under head of "Iron." The breakage of steel rails in winter is also ascribed to the increased rigidity of the road bed.

(32) W. W. M. asks: What will clean metallic zinc? A. Dilute hydrochloric acid and sharp sand, an emery wheel, or file.

(33) E. T. M. asks: Will anything remove indelible ink from linen or cotton cloth? A. Most "indelible" ink marks may be removed by treatment with tincture of iodine or sodium hypochlorite, and, after washing, with strong ammonia water, sodium hyposulphite, or solution of cyanide of potassium. The latter should be used with care, as it is very poisonous.

(34) J. P. asks: What will remove India ink tattooing? A. The particles consist of carbon, which is insensible to any solvent applicable. It can be removed by the scalpel and, in some cases, by cauterizing.

What can I polish steel with to make it look new and like a penknife blade? A. Emery dust and oil.

(35) W. W. asks for a recipe for making a sympathetic ink to be developed by some agent other than heat. A. 1. Write with solution of ferrocyanide of potassium; develop by pressing over the dry invisible characters a piece of blotting paper moistened with solution of copper sulphate or of copperas. 2. Write with pure diluted tincture of iron; develop with a blotter moistened with strong tea.

(36) F. H. T. asks: 1. What will prevent flour paste from moulding and souring? A. Use a few drops of carbolic acid. 2. Ordinary mucilage lacks the requisite body for rapid work in wrapping up newspapers. Can you recommend a good solution for the purpose that will not spoil by freezing? A. Try the following: Four parts, by weight, of glue are allowed to soften in 15 parts of cold water for some hours, and then moderately heated till the solution becomes quite clear; 65 parts of boiling water are now added with stirring. In another vessel 30 parts of starch paste are stirred up with 20 parts of cold water, so that a thin milky fluid without lumps is obtained. Into this the boiling glue solution is poured, with constant stirring, and the whole is kept at the boiling temperature. After cooling, 10 drops of carbolic acid are added to the paste. The paste must be preserved in closed bottles to prevent evaporation of the water, and will in this way keep good for years.

(37) L. S. S. writes: Please inform me how I can purify block tin that has been a little overheated in a crucible. It leaves a wavy surface on the article plated, with streaks of dross. Can the metal be brought back to its former state? A. Cover the molten tin with charcoal mixed with rosin, oil or tallow. The dross may be recovered by strongly heating with excess of fine charcoal in a luted crucible.

(38) J. W.—What you refer to is doubtless a modification of Franklin's "pulse glass," consisting of a tube connecting two bulbs, and half filled with colored ethylic ether, air being excluded; the heat of the hand in contact with one of the bulbs expands the ether vapor and forces the liquid into the other bulb with ebullition. The violence of the ebullition is a rough index of the temperature of the blood circulating in the hand of the person grasping the bulb.

(39) F. E. P. writes: With an engine having two boilers of unequal sizes, not heated by the same fire, but both having the same pressure, if one boiler be cut off from the cylinder, say the smaller one, and the larger one will do certain work with 100 lbs. of steam, will the smaller one do the same work, provided the steam could be kept at the same pressure while working? Or, in other words, will a certain unit or pressure of steam do equal work, no matter from what sized vessel it comes, in equal cylinders? A. If the pressure could be kept at 100 lbs. in the small boiler, it would do the same work, but if the large boiler just furnished steam enough, the pressure in the small boiler would fall when it was connected directly to the engine.

(40) G. H. writes: I wish to increase the weight of my feed stone by putting more plaster upon the back of it. In what way can I do it so that it shall be solid? I have already put three new backs on, but soon after the setting I find the new plaster has risen from the old, leaving a space of from a quarter to half an inch between, rendering it impossible to turn and dress it. A. You might secure the new part by a casing, or cut grooves in the old portion so as to form a lock joint with the plaster that is added.

(41) W. G. W. writes: Suppose a young tree, say 10 feet high, has its lowest shoot 2 feet from the ground. As the tree grows will the branch get any further from the ground, or does the tree grow in length only on the top? A. The youngest parts of the tree grow faster than the older. Up to the point when the woody fibers become set the branch will rise, though slowly in comparison with the growth of the newer portions.

(42) B. T. asks: 1. What is the principle upon which the revolving gas burner works? I do not mean the one which works by a fan wheel on top and has its loose joint sealed with water, but the one which, I think, works by pressure and reaction of the gas. A. The burner revolves just as a rocket ascends, because there is unbalanced pressure in one direction. 2. How is the joint made, and what seals it? A. The revolving arm is fitted nicely to the upright pipe, generally without packing.

(43) B. M. R. asks: How can I wash India ink stains from marble? A. Use plenty of hot water, and if necessary rub with a little rouge on a soft cloth.

(44) G. S. N. writes: I want to arrange some way for communicating between mill and store. Which would you advise, telegraph or telephone? Will the noise of the mill interfere with the working of the telephone? A. In your case the dial or printing telegraph would perhaps be best.

(45) E. J. asks: How many degrees of heat can steam be heated to, by passing it in pipes through a furnace? A. With a proper arrangement of pipes, we think the steam could be heated to any temperature that the pipes would stand.

(46) T. H. writes: I am an apprentice in a railroad repair shop; have served two years, and have two more to serve. What book will help me to fully understand the working of an engine, and also how to take proper care of the boiler? A. No one book will give you this information, and much of it is not contained in books at all. Forney's "Catechism of the Locomotive," Bourne's "Catechism of the Steam Engine" and "Hand Book," Auchincloss on "Link and Valve Motions," and Rigg's "Practical Treatise on the Steam Engine," will form a good selection for a commencement of a course of reading on the subject.

(47) J. G. writes: In books on the steam engine it is said that some valves have too much lift, and some too little, but they do not say what is too much and what too little. What is the rule? A. The general idea in proportioning the lift is to give sufficient area of opening. It frequently happens, however, that on account of the size of the valves or the speed of the pump the valves seat heavily, in which case the lift can sometimes be reduced advantageously; but the exact amount of reduction can best be determined by experiment.

(48) T. R. W. asks: What time does it generally require to become an expert stenographer (Pitman's system) and what salary is paid? A. So much depends upon the capacity of the learner, that a general answer cannot be given. Some learn in three or four months, with one or two months' additional practice. The pay is not very high at present, as the supply rather exceeds the demand.

(49) L. D. L. asks: How can I restore the color of ink in faded manuscripts? A. Carefully wash the manuscript in a weak and cold decoction of ground nutgalls. In regard to other inquiry, consult advertising columns.

(50) T. W. asks: How can pins of metal be safely and securely fastened in holes in glass? Will not the metal expand and break the glass? Should the glass be moulded on and over the heads of the pins, and would this prevent breaking of the glass? A. Under ordinary conditions of temperature there would probably be no danger. It would be better, however, to use a cement. If not required to stand very high heat, melted resin with a little calcined plaster stirred in, thinned with boiled oil, and applied warm, would answer.

(51) W. E. K. asks: 1. What process have electro-platers for finishing steel knives that are corroded? The knives will not stand grinding down and refinishing, as the spots are sometimes opposite each other; if they were all ground out the blades would be too thin for service. A. There are several ways of doing this. One good way is to fill the depressions with silver, by repeating the operation of silver plating, and polishing until a flat surface is obtained. 2. Is there any machine made for burnishing silver plated articles, or does it have to be done by hand? A. Yes; but fine burnishing is done by hand.

(52) F. B. writes: 1. I inclose a piece of wire which I intend using for telegraph purposes. Is it large enough to conduct a current from a small battery? A. The sample is of about 19 gauge, and will answer for the purpose. 2. Is it necessary to have it galvanized? A. No.

(53) M. C. writes: About 20 years ago, while living in Wisconsin, I saw hundreds of large white grubs, dead, with a vegetable sprout issuing from their backs. They were ploughed up by my neighbors in the spring. The shoots looked like young corn, having two straight and beautiful leaves. The grubs had turned to a dark color, nearly brown. I planted several of the shoots, but they failed to grow. I think that this is a tough nut for Mr. Darwin. A. Darwin is not an advocate of spontaneous generation. The natural explanation of the fact mentioned is that the grubs, after swallowing the plant germs (which were probably something smaller than grains of corn), were killed in some way, and the seeds in sprouting found congenial nutriment in the bodies of the larvæ.

(54) W. A. M. writes: I am endeavoring to construct a telephone, but find many difficulties in the way. The distance over which I wish to use it is, say, 150 yards. I have a single copper wire, a sample of which I inclose. I also have a Leclanché or open circuit battery, and at the opposite end of line I have an electric bell. Now I wish to use the electric bell for calling attention to the telephone in my factory, where there is some noise caused by the working of machinery. 1. Can I work the telephone successfully on the single wire—same wire used by the bell and battery? A. Yes. 2. I inclose a sample of wire wound on my spools on magnets; spools contain $\frac{3}{4}$ oz. each. Is the wire not too fine or light? (The sample is of about No. 40 gauge copper wire, silk insulation, and is of the right size and quality to give a good result. 3. Is the quantity too small? A. That will depend on the size of the magnetic core on which it is wound. 4. I find difficulty in wrapping wire evenly on spools. Is it important to have it wound very evenly, like thread on spools? A. It is best to have it wound evenly, but not necessary. 5. If so, how can I do it? A. By winding the spool in a machine constructed on the principle of the screw cutting lathe. 6. Is the sample of sheet iron (tin type) too heavy for the diaphragms for the tele-

phone? A. The plate is of the right thickness (about $\frac{1}{16}$ of an inch), but there is too much lacquer and colloid on it. This you can easily remove by making the plate red hot.

(55) H. A. H. writes: I have been making some batteries of the following description, costing 8 cents per element. Will you please tell me how many elements I shall need to produce an electric light of 20 candle power? Glass tumbler 5 cents, small flowerpot 2 cents, zinc, etc., 1 cent. A. About 300 of them, if the sulphate of copper solution is used as an excitant.

(56) O. C. M. asks: What is the mode of nickel plating without a battery? A. Herr Stolba's process for nickel plating iron and steel without a separate battery is as follows: To a dilute solution (5 to 10 per cent) of pure zinc chloride, there is added enough sulphate of nickel to color it distinctly green. This is heated to boiling in a porcelain or porcelain-enameled iron vessel. The objects, being completely cleaned of grease, are then suspended in the liquid so that they do not touch each other. The liquid is boiled for an hour, water being added to replace that lost by evaporation. If during boiling the solution partially loses its color more nickel sulphate must be added until the intense green color is restored. The plated work must be thoroughly washed on removal from the bath in hot water holding fine chalk in suspension. It dries quickly on withdrawing from the hot water, and may then be cleaned with chalk and polished. The nickel bath, after exposure to the air for a time, may be filtered and used again.

(57) K. S. J. asks for a recipe for tempering and case-hardening small steel castings. A. Good cast steel will harden if heated to cherry red and quenched cold in clean water. If the steel is inferior, add salt to the water, and apply powdered prussiate of potash to the steel while heated.

(58) A. J. S. asks: 1. What is the cause of the drumming noise made in the firebox of a locomotive burning soft coal? A. It is probably due to careless firing, holes being allowed to burn in the fire. 2. Why does the noise increase when running through a cut or over a bridge? A. It is especially noticeable when the surroundings are such as to reflect back the sound or act as sounding boards.

(59) W. A. asks: Is there any more danger in running a boiler that leaks than one that does not leak, everything else being equal, the leaking boiler kept well supplied with water? A. It is not especially dangerous if the attendant is careful, and the pump is of ample capacity, but it is not a very creditable practice.

(60) G. B. C. asks: How can I make a bright green writing ink? A. Use a strong solution, in water, of Pirrier's methyl green. Gum dextrin may be added to the solution if required.

(61) S. B. M. asks: How is the nickel solution for plating prepared? A. Dissolve sulphate of nickel and ammonia in water— $\frac{3}{4}$ lb. to the gallon. 2. What kind of nickel is used? A. Metallic nickel in cast plates is used for anodes.

(62) J. N. D. asks: How much fine gold does the American twenty-dollar piece contain? A. It contains 516 grains 900 fine; that is, 464.4 grains pure gold.

(63) R. M. asks: How can India rubber be dissolved so as to be capable of being moulded? A. The best solvent for caoutchouc is bisulphide of carbon, to which about 6 per cent of absolute alcohol has been added. Caoutchouc is usually moulded by softening by steam heat and pressing the dough-like substance into the moulds. Solution of alum may be used on plaster of Paris moulds to prevent the rubber from adhering.

(64) J. B. asks: What are the tests for linseed oil? A. The following tests may be applied: 1. The specific gravity should be 0.9347. 2. A few drops of the oil under examination should be poured into a small porcelain capsule and exposed to the heat of a spirit lamp. The odor which is evolved is characteristic. 3. By mixing a small quantity of concentrated sulphuric acid with some of the oil (in proportion of 1 or 2 parts of the former to 100 parts of oil), very intense action immediately ensues. The temperature increases, and the mixture becomes colored a dark brownish-red, which is gradually converted into a brownish-black. 4. Add 1 drop saturated solution of bichromate of potash to 20 drops of oil: small brown lumps are formed on a ground colored green by the chrome.

(65) S. J. F. asks: How can I make what is called a "lead tree"? A. Suspend several small scraps of clean zinc by a cord in a strong aqueous solution of acetate of lead. The vessel should be sealed, to prevent loss of water by evaporation and contamination by dust.

(66) J. N. W. asks: How can I separate the hydrogen from the oxygen in water, and preserve both separately? A. The decomposition of water may be effected by voltaic electricity. When water is acidulated so as to render it a conductor, and a portion interposed between a pair of platinum plates connected with the extremities of a voltaic apparatus of moderate power, decomposition of the liquid takes place; oxygen in a state of purity is evolved from the water in contact with the plate belonging to the copper end of the battery, and hydrogen is disengaged at the plate connected with the zinc extremity. By inverting small graduated jars (previously filled with water, which the gases supplant) over the platinum plates, the gases can be collected and measured.

(67) J. A. H., Jr., J. H. S., E. C. W., and others ask for a recipe for ebonizing wood. A. Brazil wood, powdered nutgalls, and alum are boiled in water until a blackish color is obtained; the liquid is filtered and applied to the wood, which is then washed in a liquor made by digesting strong vinegar and a little oil of vitriol for some time with excess of iron turnings; thoroughly wash the wood, dry and oil.

For staining fine woods the following is applicable: 4 ozs. of gallnuts, 1 oz. powdered logwood, $\frac{1}{2}$ oz. green vitriol, and $\frac{1}{2}$ oz. verdigris are boiled with water, and the solution, filtered hot, is applied to the wood, which

is then coated with a solution of 1 oz. fine iron filings dissolved by digestion in a small quantity of hot wine vinegar. See also pp. 191 and 219, current volume.

(68) C. M. asks whether the use of corrosive sublimate for destroying moths is dangerous. A. Camphor is safer.

(69) L. E. L. asks how to make chloride of cobalt. A. Dissolve oxide of cobalt in hot hydrochloric acid, on the water bath; filter, evaporate to dryness. The residue (chloride of cobalt) is soluble in water.

(70) J. E. L. asks: On connecting a battery with a pair of Bell telephones they work louder. Would it be detrimental in any way to the telephones to work them with the battery? A. Not if you connect the battery so that its current, in passing through the spool of wire in the telephone, will tend to increase the magnetism of its core, as may be shown by a compass placed near the spool end of the telephone. See answer 15, p. 155, of SCIENTIFIC AMERICAN of March 9, 1878.

(71) F. D. S. writes: I wish to make a cellar bottom impervious to dampness. Would coatings of pitch with 8-ply felting paper accomplish this object? A. If the cellar is properly drained this, if well laid with sand and floored with wood, will answer. A good cement would, however, be preferable.

(72) E. T. and J. W. Y. ask for a recipe for varnish suitable for walnut, etc. A. The following is recommended: Japan, 2 quarts; coach varnish, 1 quart; turpentine spirits, 1 quart; beeswax, 4 ozs. Shave the wax up thin, put it in the turpentine in a tin vessel, and place the latter in hot water until its contents are fused; then add it to the other ingredients and shake well. The varnish should be of the best quality. The mixture dries without tack and has a beautiful soft appearance; it is suitable for either inside or outside work.

(73) F. H. asks: 1. What amount of steam pressure per square inch would be required to secure a pressure of 40 lbs. to the square inch of compressed air? A. It will depend on the arrangement of the compressing apparatus. With direct compression, a steam pressure of from 45 to 50 lbs. will generally be required. 2. How many degrees of heat does air compressed receive for every 10 lbs. of pressure? Air compressed to 70 lbs. per square inch is expanded in a cylinder: what amount of pressure per square inch would it exert upon a press? A. See question 26, in SCIENTIFIC AMERICAN for October 7, 1876. 3. Does air compressed offer a greater resistance to power applied in proportion to the pressure per square inch obtained? A. As we understand your meaning, no.

(74) C. H. H. asks: 1. Would there be any more harm in leaving the fire in a steam thrashing machine, when moving, with 75 lbs. of steam, than there would be in pulling out the fire and reducing the pressure to 40 lbs. or less by pumping in cold water? Would the flues be more apt to leak by leaving the fire in and carrying the higher pressure? A. No. 2. If the rings on a piston head are expanded by steam, ought they to leak when the back head of the cylinder is off, the driver blocked, and steam is turned on, and ought the pressure to make any difference whether it is 60 or 120 lbs.? A. They should be tight under the circumstances. 3. Which is the more economical, an automatic cut-off or a governor on an engine with a common slide valve? A. The former, generally, as the two styles are constructed. 4. How do you compute the power of an engine by the friction brake? A. Multiply the weight on the brake in lbs. by the distance it would move in feet per minute, if free to revolve, and divide the product by 33,000.

Are the days and nights on the equator of the same length the year round, and would any perpendicular object be without a shadow at 12 noon? A. No.

(75) C. W. R. asks: How is the case hardening done, which produces a variety of colors, such as you will see on fine guns? A. Surround the articles with animal or vegetable charcoal, and inclose them in a tight case. Expose to a dull red heat for from 2 to 8 hours, according to the depth of hardening required. A quicker process is to heat the iron, sprinkle prussiate of potash upon it, expose to a dull red heat for a few minutes, and then temper in water. See (57).

(76) H. M. R. asks: 1. How shall I manage to make a few castings for a small horizontal engine? A. You will find it very troublesome to make such castings yourself, and had better send the patterns to the foundry. For full particulars how to mould a pattern see SCIENTIFIC AMERICAN, Nos. 2 and 15, vol. 35. 2. What is the process by which a metal is hardened after being cast? A. By heating it to a red heat and cooling it quickly; but cast iron is apt to crack if plunged in water, and is therefore hardened by being chilled in an iron mould. 3. How are the metals brought to such a fine polish, such as I have seen on the principal parts of small models and fine machinery? A. By fine filing and burnishing.

What battery is required for running a small electric engine (horizontal) about double the size of engraving on p. 301, SUPPLEMENT, No. 19? A. Two Bunsen cells would probably run such an engine.

(77) S. D. C. writes: What is the best press for hand power to strike medals in bronze, say 2 to 2½ inches in diameter, also amount of power required for same? A. For hand power we know of nothing better for the purpose than the drop hammer. To force them into shape by a pressure exerted slowly, would require the use of a hydraulic press (such as is used at the mint) and capable of exerting a pressure of about 100 tons.

(78) H. S. asks: How can cracks in marble be obliterated? A. Use a mixture of powdered marble of suitable color and a little pulverized flint glass with a thin paste, made by dissolving 4 parts pale shellac and one part borax in hot water and concentrating by heat. The ground tint of the marble must be imitated by addition of suitable pigments if necessary. Emery and rouge are used to polish when sufficiently hardened.

What is a good walnut stain? A. See SCIENTIFIC AMERICAN, July 7, 1877, p. 11 (8).

How can a fine polish be put on walnut? A. Rub the work over with boiled linseed oil, and when nearly dry, rub it over with a stiff brush. Take a strip of woollen

cloth about two yards long, roll it up into a hard roll. Dip one end into the boiled oil, and add a few drops of shellac varnish, and rub the work previously oiled with that until a fine polish is obtained.

How can I mend a rubber hose having small holes in it? A. With rubber cement, which you can obtain from dealers in rubber goods. Caoutchouc, dissolved in chloroform, will fill very small holes.

MINERALS, ETC.—Specimens have been received from the following correspondents, and examined, with the results stated:

J. McE.—It is a rich ore of lead—galena.—S. C. C.—A poor iron ore—argillaceous limonite—W. A. M.—The incrustation consists for the most part of lime sulphate and carbonate, together with a little silica, alumina, iron, and organic matter. The remedies suggested will, in time, soften but not remove it.—C. F. B.—Quartz, of no special value.—J. H. P.—No. 1, Quartzite with specular and titaniferous iron. The green piece contains copper oxide, silicate, sulphide, and carbonate, together with much iron. No. 2. A limestone. No. 3 resembles No. 1. Nos. 4, 12, and 13, conglomerate. No. 5. Hematite with crocidolite. No. 6. Quartz containing siderite. No. 7. Lithographic stone. No. 8. Limestone with pyrites and a trace of copper sulphide. No. 9. Red jasper. No. 10 contains specular iron. No. 11. Limestone. No. 14. Barite—impure barium sulphate. It occurs commonly in beds or veins of metallic ore.

COMMUNICATIONS RECEIVED.

The Editor of the SCIENTIFIC AMERICAN acknowledges with much pleasure the receipt of original papers and contributions on the following subjects:

- Progress of the Plow. By F. W. J.
Preventing Explosions in Mines. By F. P. and A. D.
Safeguard against Counterfeiting. By E. A. H.
Locomotive Strokes. By W. St. L.
Our Earth Motionless. By S.
The Locomotive Engine. By F. I.
The Polariscopes a Photometer. By P. H. V.

OFFICIAL.

INDEX OF INVENTIONS

FOR WHICH Letters Patent of the United States were Granted in the Week Ending March 12, 1878, AND EACH BEARING THAT DATE.

[Those marked (r) are reissued patents.]

A complete copy of any patent in the annexed list, including both the specifications and drawings, will be furnished from this office for one dollar. In ordering, please state the number and date of the patent desired, and remit to Munn & Co., 37 Park Row, New York city.

Table listing various inventions such as Advertising apparatus, Alarm register, Animal trap, Axle skin tie rod, Bedstead, Beer preserving, Bit stock, Boiler, Broom, Brush, Buckle, Bung turning machine, Button, Can, Car coupling, Car door, Car sleeping, Cars, Carpet pad, Cart body, Chain, Chair, Cigar package, Clock, Cloth finishing, Clutching device, Coal breaker, Coffee pot, Coffin fastener, Coffin fastener, Coin holder, Corn holder, Corset, Corset clasp, Cotton chopper, Coupling link, Cranberry picker, Crayons, Cultivator, Cultivator tooth, Curtain tassel, Drawing and spinning, Effervescent liquid apparatus, Electric machine, Electrode for curative purposes, Engine, Engine, rotary, Engine, rotary, Evaporating pan, Exercising device, Fan attachment, Feed water heater, Fence post, Filter, Fire alarm, Fire arm, Fire extinguisher, Fire kindler, Flat iron heater, Flour chest, Flying machine, Fountain, Frog, Fruit drier, Furnace, Furnace, C. W. Siemens, Furnace, C. Caddick, Gang edger, Garment supporter, Gas lighting device, Gas machine, Gas regulator, Gate, Gate, H. S. Wolfe, Gate, draw bridge, Grain binder, Grain binder, Baker & Withington, Grain binder, E. Dederick, Grain cleaner and scourer, Grain cleaning and scouring machine, Grain separator, Grater, Grater, Watkins & Carey, Harvester rake, Harvester rake, J. Miller (r), Harvester reel, Hat brims, Hat brims, curling, Hinge, Hinge, T. T. Bishop, Hinge for awning blinds, Hog catcher, Holdback for vehicles, Horse power, Horseshoe nail machine, Hydrant, Hydraulic jack, Illuminating flames, Instant, W. A. Hull, Jewelry, Journal box, Keyhole guard, Knob alarm, Labels, machine for cutting, Lamp burner, Lamp stand, Last block fastener, Level and plumb, Lifting jack, Lock, seal, Locomotive, Locomotive, G. Vincent, Lubricator, Lubricator, axle, Mail bag, Medication oil, Middlings separator, Motion, converting, Muclage holder, Muclage holder, Music rack, Musical top, Needle sharpener, Nut lock, Oiler, Oiling wagon wheels, Organ reed, Oven shelf, Padlock, Palmetto leaves, Paper bag machine, Paper pulp manufacture, Paper pulp, reducing wood to, Patterns, grading, Paving compound, Photographic camera, Planter and fertilizer distributor, Plow, Bogenrief & Pattison, Plow, Burns & McElhany, Plow, E. J. Camp, Plow, Nourse & Howe, Plow clevis, Plow frame, gang, Plow, hilling, G. A. De Long, Plow, sulky, T. B. Chamberlin, Pocketbook fastening, Power, transmitting, Press for marking cigars, Pressure regulator, Pressure regulator, Printing press, Propeller for vessels, Propeller, W. S. Davis, Pump, J. C. Rundlett, Radiator, Rail joint, Rake, Range, W. H. Barnes, Rivets, Rivets, cutting, Rolling plate metal, Roof, ridge saddle, Saddle tree, Sash holder, Saw handle, Saw mill head block, Saw sharpening machine, Scoop, measure, and sieve, Screw, drive, Scythe fastenings, Seaming, etc., metal pipes, Seeding machine, Sewer gas trap, Sewer trap, Sewing machine take up, Sheet metal flanging machine, Shock binder, Shoe fastener, Shoe fastener, E. Rees, Shoe tree, Shoe maker's tool heater, Shutter, Sideboard and dining table, Siphon, Sleigh standard, Spinning machine, Spinning ring, Spring for mattresses, Sprinkling pipe, Stalls for vessels, Steam and fume box, Stench trap, Stove, cooking, Stove evaporator, Stove, heating, Stoves, fire box, Stump puller, Sugar pressing machine, Surveying instruments, Switch head chair, Tap and faucet, Target thrower, Tea, coffee, etc., apparatus, Telegraph key, Thill coupling, Tobacco, device for handling, Tobacco, package, Tobacco spraying apparatus, Toy, bell, Toy, pistol, Trace trimming machine, Truck, car, Truck, car, Banger & Hurd, Truck, car, G. Vincent, Truck, car, Vincent & Wheaton, Tubing upon spindles, Valve, balanced slide, Vault, ash and garbage, Vehicle running gear, Velocipede, Velocipede, ice, Ventilator or smoke cowl, Wash boiler, Washing machine, Washing machine, J. W. Calef, Washing machine, C. A. Dodge, Washing machine, E. O. Rood, Water meter, Water pipe, trap, Water trap, Water wheel, turbine, Trip, Well tools, joint for oil, Wells, elevator and clamp for oil, Windmill, Windmill, O. H. Quie, Wood, ornamenting, Yarn, dressing or sizing.

Table listing various inventions such as Thill coupling, Tobacco, device for handling, Tobacco, package, Tobacco spraying apparatus, Toy, bell, Toy, pistol, Trace trimming machine, Truck, car, Truck, car, Banger & Hurd, Truck, car, G. Vincent, Truck, car, Vincent & Wheaton, Tubing upon spindles, Valve, balanced slide, Vault, ash and garbage, Vehicle running gear, Velocipede, Velocipede, ice, Ventilator or smoke cowl, Wash boiler, Washing machine, Washing machine, J. W. Calef, Washing machine, C. A. Dodge, Washing machine, E. O. Rood, Water meter, Water pipe, trap, Water trap, Water wheel, turbine, Trip, Well tools, joint for oil, Wells, elevator and clamp for oil, Windmill, Windmill, O. H. Quie, Wood, ornamenting, Yarn, dressing or sizing.

Table listing various inventions such as Thill coupling, Tobacco, device for handling, Tobacco, package, Tobacco spraying apparatus, Toy, bell, Toy, pistol, Trace trimming machine, Truck, car, Truck, car, Banger & Hurd, Truck, car, G. Vincent, Truck, car, Vincent & Wheaton, Tubing upon spindles, Valve, balanced slide, Vault, ash and garbage, Vehicle running gear, Velocipede, Velocipede, ice, Ventilator or smoke cowl, Wash boiler, Washing machine, Washing machine, J. W. Calef, Washing machine, C. A. Dodge, Washing machine, E. O. Rood, Water meter, Water pipe, trap, Water trap, Water wheel, turbine, Trip, Well tools, joint for oil, Wells, elevator and clamp for oil, Windmill, Windmill, O. H. Quie, Wood, ornamenting, Yarn, dressing or sizing.

English Patents Issued to Americans.

February 23 to March 14, inclusive. Celluloid manufacture.—Cell. Manuf. Co., N. Y. city. Chain manufacture.—J. H. Helm, Allegheny, Pa. Electric machine.—H. C. Spalding, Bloomfield, N. J. Filter.—A. Van Haagen, Philadelphia, Pa. Furnace.—S. T. Owens et al., Allegheny, Pa. Hose.—S. W. Baker, Providence, R. I. Life boat, J. F. Schultheis, N. Y. city. Middlings, dressing, etc.—T. D. Jones, Syracuse, N. Y. Moulding machine.—W. Munzer et al., N. Y. city. Rail joint.—E. Payne, Chicago, Ill. Railway switch.—J. S. Williams, Riverton, N. J. Ribbon roll.—H. G. Hubert et al., N. Y. city. Rock drill.—W. W. Dunn, San Francisco, Cal. Screw machine.—C. D. Rogers, Providence, R. I. Sewing machine.—J. E. Folk, Brooklyn, N. Y. Shot concentrator.—R. Morris, U. S. A., et al. Sickle grinding machine.—W. S. Ingraham, Waukegan, Ill. Spinning machine.—F. Rabbeth, Pawtucket, R. I. Stopper.—W. H. Hicks, Brooklyn, N. Y. Syringe.—M. Mattson, N. Y. city. Transmitting power.—W. H. Clark et al., Chicago, Ill. Vehicle for self-propulsion.—G. W. Bishop, Brooklyn, N. Y. Wheel for vehicles.—T. H. King, San Francisco, Cal. Window cleaning chair.—Mrs. A. Dormitzer, N. Y. city.



CAVEATS, COPYRIGHTS, TRADE MARKS, ETC.

Messrs. Munn & Co., in connection with the publication of the SCIENTIFIC AMERICAN, continue to examine Improvements, and to act as Solicitors of Patents for Inventors.

In this line of business they have had over THIRTY YEARS' EXPERIENCE, and now have unequalled facilities for the preparation of Patent Drawings, Specifications, and the Prosecution of Applications for Patents in the United States, Canada, and Foreign Countries. Messrs. Munn & Co. also attend to the preparation of Caveats, Trade Mark Regulations, Copyrights for Books, Labels, Reissues, Assignments, and Reports on Infringements of Patents. All business intrusted to them is done with special care and promptness, on very moderate terms.

We send free of charge, on application, a pamphlet containing further information about Patents and how to procure them; directions concerning Trade Marks, Copyrights, Designs, Patents, Appeals, Reissues, Infringements, Assignments, Rejected Cases, Hints on the Sale of Patents, etc.

Foreign Patents.—We also send, free of charge, a Synopsis of Foreign Patent Laws, showing the cost and method of securing patents in all the principal countries of the world. American inventors should bear in mind that, as a general rule, any invention that is valuable to the patentee in this country is worth equally as much in England and some other foreign countries. Five patents—embracing Canadian, English, German, French, and Belgian—will secure to an inventor the exclusive monopoly to his discovery among about ONE HUNDRED AND FIFTY MILLIONS of the most intelligent people in the world. The facilities of business and steam communication are such that patents can be obtained abroad by our citizens almost as easily as at home. The expense to apply for an English patent is \$75; German, \$100; French, \$100; Belgian, \$100; Canadian, \$50.

Copies of Patents.—Persons desiring any patent issued from 1836 to November 26, 1867, can be supplied with official copies at reasonable cost, the price depending upon the extent of drawings and length of specifications.

Any patent issued since November 27, 1867, at which time the Patent Office commenced printing the drawings and specifications, may be had by remitting to this office \$1.

A copy of the claims of any patent issued since 1836 will be furnished for \$1.

When ordering copies, please remit for the same as above, and state name of patentee, title of invention, and date of patent.

A pamphlet, containing full directions for obtaining United States patents sent free. A handsomely bound Reference Book, gilt edges, contains 140 pages and many engravings and tables important to every patentee and mechanic, and is a useful hand book of reference for everybody. Price 25 cents, mailed free.

Address MUNN & CO., Publishers SCIENTIFIC AMERICAN, 37 Park Row, N. Y. BRANCH OFFICE—Corner of F and 7th Streets, Washington, D. C.

Advertisements. Inside Page, each insertion --- 75 cents a line. Back Page, each insertion --- \$1.00 a line. (About eight words to a line.) Engravings may be had advertisements at the same rate per line, by measurement, as the letter press. Advertisements must be received at publication office as early as Thursday morning to appear in next issue.

This Work is Very Reliable, and is Strongly Recommended by this Paper.

ALLEN'S ARTIFICER'S ASSISTANT.

THE SCIENTIFIC AMERICAN says of this work: "This is undoubtedly the cheapest work of the kind ever published. It contains 700 pages of closely arranged matter. The author and compiler have covered very extensive ground, and the recipes and instructions given are of the latest date, and are ever published, very many of which have been obtained with difficulty and at a great expense." THE SCIENTIFIC AMERICAN says of this work: "This is undoubtedly the cheapest work of the kind ever published. It contains 700 pages of closely arranged matter. The author and compiler have covered very extensive ground, and the recipes and instructions given are of the latest date, and are ever published, very many of which have been obtained with difficulty and at a great expense." Among the multitude of subjects of which it treats, will be found the following: Telegraphy, of which it is a perfect self-instructor, teaching the construction, manipulation and management of Instruments, Batteries, Wires, &c.; Reading by sound, The Learner's Instructions, How to learn telegraphy at home in short time. One Hundred and Fifty valuable Mechanical Movements; Illustrated and Explained. Information concerning Patents; how to obtain them. Tuning the Piano-forte, Organ, Melodeon, a complete self-instructor. Watchmaking, the whole process of manufacture in detail. Watch-makers' Train Tables. Directions for the construction and management of Engines, Boilers, Gauges, Valves, &c.; Duties of Engineers. Cement for Steam work, Composition Boiler Covering, Steam packing, Scale preventatives, Polish for bright work; Useful hints for Millers and Millwrights; Saw Mills and Shingle Machines, Rules for speed of Wheels, Pulleys, Drums, Circular Saws, &c.; Saw filing, full directions; Mending Broken Saws, Shaping Belting; Gear Cutting, Bevel Gears, Friction Paper Pulleys, Screw work, Planing, Boring, Turning, Finishing, &c.; Making and Tempering Railway and Carriage Springs, Saws, Axes, Steel Ploughs, Files, Taps, Reamers, Cold Chisels, Marble and Stone Cutters, Tools, Stone Drills, Dies, Mill Picks, Edge Tools, Scissors, Razors, Scythes, Gun Lock Springs, Watch Springs; Emery Wheels, different kinds; Tempering Liquids, 7 kinds; Metallic Tempering Bath; Case Hardening, 6 ways; to Restore Burnt Steel, 4 ways; Annealing Steel, &c. To toughen and improve poor Steel and Iron; to Reduce Oxides; Alloys for Gold, Silver, Brass, Bronze, German Silver, &c., 350 kinds; Solders, 75 kinds; 100 Compositions for Locomotive, Organ Pipes, Pumps, Telescopes, Plated Goods, Gongs, Cymbals, Metals, &c., &c.; 26 receipts for Tinning, Bluing, Galvanizing, Coppering, Brassing, Zincing, and Enameling on metals; 77 recipes for Bronzes, Dipping, Acids, Lacquers, Paints, Japans, &c., for metal work. Bronze Powder, 9 kinds. 24 receipts for Coloring, Gilding and Plating; 375 very valuable receipts for Watch, Chronometer, Clock and Jewelry work. Over 1,000 reliable processes for Iron, Steel, Saw, Tube, Chain, Anvil, Sewing Machine, Gas fixture, and Firearm Manufacturers, Master Mechanics, Machinists, Engineers, Blacksmiths, Horseshoers, Carriage Makers, Iron, Brass, Type and Bell Founders, Pattern Makers, Refiners, Gunsmiths, Cutlers, Millwrights, Coppermiths, Gas and Steam Fitters, Plumbers, Marble workers, Opticians, Die sinkers, Stencil cutters, &c.; Glass, Glass Staining, Etching, and China Decoration, 50 receipts; To Gold Glass Signs, 5 ways; Stains for Wood, Polishes, Wood filling, Oil Finishes, 100 kinds. 500 receipts for House, Sign, Ship, Carriage and Ornamental Painters, Grainers, Cabinet and Musical Instrument Makers, Gilders, Carvers, Polishers, Picture Frame Dealers, Varnishers, Sluco-workers, &c.; 40 receipts for Lumber, Cabinet Makers, Millwrights, Boot, Shoe and Harness Makers. 150 receipts for Dyers, Bleachers, Hatters, Clothiers, &c. For Dentists, 25 receipts; Moulders, Pattern and Model Makers' Tables, Weights of Iron, Steel, Brass, Copper, Lead, Russia Iron, &c.; Pipe, Strength of Cast Iron Columns, &c., at sight. Estimates of Supplies for Lumber, Cabinet Makers, Millwrights, Patterners and Contractors. Diagrams for Machinists. Full instructions for making Artificial Flowers, Fruit, &c., for taking Ferrotypes, Tintype, and other positive pictures; for Making, Bottling and preserving all kinds of Ales, Wines, Spirits, &c., 150 receipts. For manufacturing Confectionery of all kinds, 120 receipts; The Art of Brewing; Cage Birds and their Diseases, Taxidermy; Rules for the Games of Billiards, Pool, &c. Book-keeping, by both double and single entry, condensed and comprehensive; valuable information for Farmers, in regard to Hires, Cattle, Poultry, Composts, &c. More than 100 Receipts for Pickling, Baking, Preserving, Pickling, &c. There is so much that is valuable in this work that we can give only a faint idea of its contents. AGENTS WANTED. LIBERAL COMMISSION. SENT BY MAIL, POSTAGE PAID, FOR \$2.50. Address M. E. ALLEN & CO., 39 BERNARD STREET, NEW YORK. P. O. Box 3750.

THE FLOW OF METALS. BY DAVID TOWNSEND. Valuable experiments, with ten engravings, on flowing through thick plates, and a flow of metal. Effect of Flow on Dimensions, Density, etc. of Plate. Lines of Least Resistance, etc. Punching with and across the grain. Practical Applications. Contained in SCIENTIFIC AMERICAN SUPPLEMENT No. 119. Price 10 cents. To be had at this office and of all newsdealers.

LIQUID FUELS. BY H. AYDON. A paper read before the Institution of Civil Engineers, London. The five methods of burning liquid fuel, C. J. Richardson, M. J. and B. A. Aydon, and D. J. F. Practical Working of each method, and comparative economy. Contained in SCIENTIFIC AMERICAN SUPPLEMENT No. 119. Price 10 cents. To be had at this office and of all newsdealers.

The Co-Operative Newspapers.

It has been asserted that one-half of all money paid by New York advertisers for advertising outside of that city goes to the CO-OPERATIVE NEWS-PAPERS. If this statement is true there is no occasion for surprise that prominent papers which are still charging war prices for advertising feel called upon to abuse a rival with which they find themselves unable to maintain a competition.

Full particulars about the Co-operative Newspapers, together with catalogues and advertising rates, mailed free on application to BEALS & FOSTER, General Agts AMERICAN NEWSPAPER UNION, 41 Park Row, New York.

MANUFACTURERS OF MACHINES OR Instruments suitable for England, India, or the Colonies, are requested to communicate with the advertisers, who have an extensive and well established connection in those markets and make a speciality of the goods referred to. Ample references will be given. Address J. W. WAINWRIGHT, Cambridge Street Buildings, Birmingham, England.

A GENTLEMAN THOROUGH BUSINESS man, connected with a large firm, is desirous of taking the representation or sole agency of responsible parties for Germany in good, salable articles. Liberal advances made; best of references given. Mechanical branch and machinery preferred. Please address H. HOEFER, 71 Nassau St., New York.

Say where you saw this. Clampon Combination and Youth's Combination Foot Lathes, Engines & Boilers, Cylinder Saws and Stave Machines. Send stamp for price. Strange's Cylinder Saw & Mach. Co. Taunton Mass.

WANTED Partiers to represent us every where for our new Combined Plan for Operating Stocks. Profits sure. No "puts" or "calls." Liberal salary. No interference with other business. All kinds of bonds wanted. Circulars and private terms free. Lawrence & Co., Bankers, 21 Broad St., N. Y.

FLETCHER'S GAS FURNACE will melt half a pound of Gold, Silver, Iron, Brass, etc., in a few minutes. ILLUSTRATED PRICE LISTS OF LABORATORY APPARATUS, GAS FURNACES, etc., on application. BUFFALO DENTAL MANUFACTURING CO., 307 and 309 Main St., Buffalo, N. Y.

ON THE PRESERVATION OF WOOD. By J. CLARK JEFFERSON, A.R.S.M. How to store timber. How to measure timber and judge of its quality. Causes and Prevention of Dry and Damp Rot. Durability and Preservation of timber in Mines. The three methods of Artificial Preservation: 1. Coating timber with Tar, etc. 2. Removing Sap by water or by steam. 3. Impregnating the wood by a solution of common salt, Sulphide of Barium, Sulphate of Zinc and Copper, etc. A valuable practical paper. Contained in SCIENTIFIC AMERICAN SUPPLEMENT No. 119. Price 10 cents. To be had at this office and of all newsdealers.

RATS can be easily caught in any good trap, by using "Ratena" for bait. AND MICE Sold everywhere. Price 25c. by mail. Lyman & Co. Brevoort Station, Kings Co., N. Y.

Founded by Mathew Carey, 1785.

BAIRD'S BOOKS

FOR PRACTICAL MEN.

To our business of Industrial Publishers we have added that of Industrial Booksellers and Importers, and have now on hand a valuable stock of ENGLISH and AMERICAN PRACTICAL AND SCIENTIFIC BOOKS, including the most recent issues from the English and American press.

Our new and enlarged CATALOGUE OF PRACTICAL AND SCIENTIFIC BOOKS—96 pages, 8vo.—sent free to any one who will furnish his address.

A Select list of Books on Metals, Metallurgy, Strength of Materials, Chemical Analysis, etc.; also, one on Steam and the Steam-Engine, as well as a Catalogue of a choice Collection of Practical, Scientific and Economic Books, with prices, sent free upon application.

HENRY BAIRD & CO., INDUSTRIAL PUBLISHERS, BOOKSELLERS & IMPORTERS, 810 WALNUT STREET, Philadelphia.

THOMAS'S STRONG BLACK No. 33 HAS been well tried, and is now in regular use by some of the best mfrs of textile goods. A better black color is made than ever before, and far cheaper. Adapted for cotton, wool, or silk. Price 10c per lb. Each pound saves 15 lbs. logwood and saves trouble of boiling. Address orders or enquiries to N. SPENCER THOMAS, Elmira, New York.

LADIES can make \$5 a day in their own city or town. Address ELLIS MAN'G CO., Waltham, Mass.

Steel Name Stamps.

N. Y. STENCIL WORKS, 87 Nassau St., N. Y.

VALUABLE PATENTS For Sale.

(No. 199,991. Feb. 5th, 1878.) Pearson's Improvement in Wax-Thread (Lock Stitch) Sewing Machines. For Boots, Saddlery and Mill Bands. Offers for above for the States and Canada to be sent to PEARSON & CO., Chadwick St., Leeds, England.

For New Illustrated Catalogue of Foot Lathes, Scroll Saws, Small Steam Engines and Amateur's Tools, send stamp to CHASE & WOODMAN, Newark, N. J.

25 Styles of Cards, 10c., or 10 Chromo Cards, 10c., with name. J. B. HUSTED, NASSAU, N. Y.

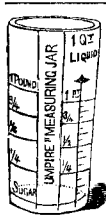

The Empire Measuring Jar.

An indispensable requisite in every kitchen and bakery for measuring, instead of weighing, sugar, flour, etc., and for liquids by the quart, pint, and fluid ounce.

Samples sent by express on receipt of 50 cts., or by mail, postpaid, on receipt of 90 cts.

Agents Wanted. Address UMPIRE GLASS CO., RICHARD E. BREED, 100 Wood St., Pittsburgh, Pa.

MILITARY AND SPORTING GUNS.

Breech Loaders and Repeating Rifles, with horizontal and vertical chamber motions, Sporting Guns, with rotary arrangement for firing either ball or shot, and Revolvers, with side motion of barrel, are manufactured by N. V. BREYER'S GUN WORKS, Sommerda, Prussia. Price lists sent gratis.

PUMPING.

Rider Compression Engine. No steam, noise, or danger. Especially for suburban residences. Pumps 2,000 to 2,000 gallons per day. CAMMEYER & SAVER, 93 Liberty St., N. Y.

HOW TO BUILD A CHEAP CATAMARAN, with Malay Rig. Four illustrations. Full directions for construction and dimensions of a simple, fast, handy boat in actual use. Contained in SCIENTIFIC AMERICAN SUPPLEMENT No. 117. Price 10 cents. Also, in same number, description and full dimensions of the new yacht Intrepid. To be had at this office and of all news-dealers.

STEAM PUMPS.—Isochronal—and—Positive—New Valve Motions. COPE & MAXWELL M'FG CO., Hamilton, O.

\$57.60 Agent's profits per week. Will prove it or forfeit \$500. New articles, just patented. Samples sent free to all. Address W. H. CHIDESTER, 218 Fulton St., N. Y.

This is the King of Lightning Calculators and Ready reckoners. Edited by GEO. E. WARING, Jr. It is not a Cook Book, but 21,000 facts of universal application, for WORKINGMEN of every trade.

576 pages, 632 illustrations; a \$5 book for \$2.75; a marvel of cheapness and rapidity of sales. 25th thousand. AGENTS WANTED. E. B. TREAT, Pub., 805 Broadway, N. Y.

AGENTS WANTED. Package of Goods free to every applicant. Star Novelty Co., Charlotte, Mich.

ICE-HOUSE AND REFRIGERATOR.

Directions and Dimensions for construction, with one illustration of cold house for preserving fruit from season to season. The air is kept dry and pure throughout the year at a temperature of from 34° to 38°. Contained in SCIENTIFIC AMERICAN SUPPLEMENT No. 116. Price 10 cents. To be had at this office and of all news-dealers.

STEAM ENGINES.

We build the best Portable or Farm Engines in the world. More power with less water and fuel than any others. Low prices. We have the largest line of Engine Patterns in the U. S. Foreign correspondence solicited. TAYLOR M'FG CO., Westminster, Md., Successors to Utica Steam Engine Co., formerly Wood & Mann, of Utica, N. Y. Good, responsible Agents wanted in territory not taken.

B. W. Payne & Sons, Corning, N. Y. Established in 1840.

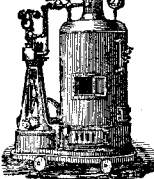

Eureka Safety Power.

h.p.	cyl.	ht.	space.	wt.	price.
2	3 1/2 x 4	48 in.	40 x 25	900	\$150
4	4 x 6	56	46 x 30	1600	250
6	5 x 7	72	72 x 42	2700	400

Also, SPARE ARRESTING PORTABLES, and Stationary Engines for Plantations. Send for Circulars.

PATENTS AT AUCTION.

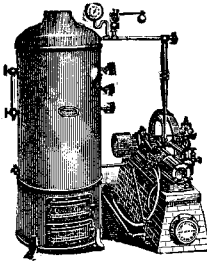

SNYDER'S "Little Giant" STEAM ENGINE.

For Farmers, Machinists, Printers, and all requiring Light Power.

Sizes from One to Six H. P. Prices for Engine and Boiler complete, from \$150 to \$450. We make the Strongest Boiler and the Best Engine in the country. Call at our Factory and examine, or send for free Illustrated and Descriptive Catalogue.

SNYDER BROS., 94 Fulton St., New York.

SPARE THE CROTON AND SAVE THE COST. Driven or Tube Wells

furnished to large consumers of Croton and Ridgewood Water. WM. D. ANDREWS & BRO., 414 Water St., N. Y., who control the patent for Green's American Driven Well.

VANDERBURGH, WELLS & CO., 18 Dutch St., cor. Fulton, N. Y. ENGRAVERS' BOX, WOOD, MACHINISTS' PATTERNS & BRAND LETTERS.

Regular Monthly Sales the first week of each month by George W. Keeler, Auctioneer, at his salesrooms, 53 and 55 Liberty Street, N. Y. For terms, etc., address The New York Patent Exchange, 53 Liberty St., N. Y.

THE DRIVEN WELL.

Town and County privileges for making Driven Wells and selling Licenses under the established American Driven Well Patent, leased by the year to responsible parties, by

WM. D. ANDREWS & BRO., NEW YORK.

EAGLE FOOT LATHES,

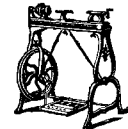

Improvement in style. Reduction in prices April 20th. Small Engine Lathes, Slide Rests, Tools, etc. Also Scroll and Circular Saw Attachments, Hand Planers, etc. Send for Catalogue of outfits for Amateurs or Artisans.

WM. L. CHASE & CO., 95 & 97 Liberty St., New York.

SALESMEN WANTED \$125 A Month and Expenses selling to DEALERS SAMPLES FREE CIGARS Send 3c. STAMP to insure answer. S. FOSTER & CO. Cincinnati, O.

50 Best Mixed Cards, with name, in case, 13c., or 25 no 2 alike, 10c. Outfit 10c. Dowd & Co., Bristol, Ct.

NEW METHOD OF ENGRAVING Moss' Process.

Photo Engraving Co.

67 Park Place, New York.

TYPE-METAL RELIEF PLATES.

A SUPERIOR SUBSTITUTE FOR WOOD-CUTS

AT MUCH LOWER PRICES.

These Relief Plates are engraved by photo-chemical means; are mounted on blocks type-high ready for use on any ordinary press, and will wear longer than the common stereotype plates.

They have a perfectly smooth printing surface, and the lines are as deep, as even, and as sharp as they could possibly be cut by hand.

Electrotypes may be made from them in the same manner as from wood-cuts.

Copy.—The engraving is done either from prints or pen-drawings. Almost all kinds of prints can be re-engraved directly from the copy, provided they be in clear, black lines or stipple, and on white, or only slightly tinted paper.

Of all Photographs, pencil-sketches, and designs in pale lines, drawings must be made with thoroughly black ink on smooth, white paper before they can be engraved. The drawings should usually be made twice the length and twice the width of the plates desired. We keep a corps of artists to do this work in the best manner. Photographs or tintypes taken in the usual way, and of any convenient size, are suitable for our use.

Change of Size.—Wood-cut prints of the coarser kind may often be reduced to half their lineal dimensions, while others will admit of very little reduction, and some of none at all.

Most lithographic and steel-plate prints will admit of no reduction.

Very fine prints of any kind may be enlarged moderately without detriment.

Any prints which cannot be satisfactorily reduced or enlarged, may be retraced and thus brought to any desired size.

In all cases of reduction or enlargement, the relative proportions remain unchanged.

Proofs.—Whenever desired, we will furnish tintype proofs of drawings made by us, for approval or correction, before engraving. A printed proof is furnished with each plate.

Time.—We cannot usually engage to fill an order for a single plate in less than from three to six days; larger orders will require longer time.

Prices.—Size alone seldom determines the price of a plate; hence we cannot furnish a scale

of prices by the square inch for miscellaneous engraving. But to publishers whose orders are regularly given, and with considerable uniformity as to the kind of work, we can give an average inch rate.

Estimates will be promptly furnished when desired. That these may be definite and correct, the copy to be used—whether print, photograph, sketch, or drawing—should always be submitted for our examination, together with a distinct statement of the size of plate wanted, and of any other details to be observed.

We Employ no Agents or Canvassers.

Terms.—To insure attention, all orders must be accompanied by an advance of half the price charged, the balance to be paid on delivery.

Plates sent by Express will be C. O. D.

Other arrangements can be made only by parties of known responsibility, or when satisfactory New-York references are given.

Small plates will be sent by mail upon receipt of price and postage.

Remittances must be made either BY DRAFTS ON NEW-YORK or by postal money orders—payable to the order of Photo-Engraving Company—or by registered letters.

Parties sending us checks on local banks will be charged with the cost of collection.

Electrotyping and Printing.—We have recently added to our establishment excellent facilities for making electrotypes, and also two power presses specially fitted for printing the larger class of plates in the finest manner.

Artificial Light.—We have just introduced this most important facility, which enables us to prosecute our work in cloudy weather, and to push forward hurried orders in the night.

References.—Our plates are now used by the principal publishers in this city, and by most of the leading houses in every state in the Union.

The George Place Machinery Agency

Machinery of Every Description. 121 Chambers and 108 Reade Streets, New York.

WROUGHT IRON BEAMS & GIRDERS

THE UNION IRON MILLS, Pittsburgh, Pa., Manufacturers of improved wrought iron Beams and Girders (patented).

The great fall which has taken place in the prices of Iron, and especially in Beams used in the construction of FIRE PROOF BUILDINGS, induces us to call the special attention of Engineers, Architects, and Builders to the undoubted advantages of now erecting Fire Proof structures; and by reference to pages 52 & 54 of our Book of Sections—which will be sent on application to those contemplating the erection of fire proof buildings—THE COST CAN BE ACCURATELY CALCULATED, the cost of insurance avoided, and the serious losses and interruption to business caused by fire; these and like considerations fully justify any additional first cost. It is believed, that, were owners fully aware of the small difference which now exists between the use of Wood and Iron, in many cases the latter would be adopted. We shall be pleased to furnish estimates for all the Beams complete, for any specific structure, so that the difference in cost may at once be ascertained. Address CARNEGIE, BROS. & CO., Pittsburgh, Pa.

Pond's Tools,

Engine Lathes, Planers, Drills, &c. Send for Catalogue. DAVID W. POND, Successor to LUCIUS W. POND, Worcester, Mass.

\$3 GOLD PLATED WATCHES. Cheapest in the known world. Sample Watch Free to Agents. Address, A. COULTER & Co., Chicago.

Lathes, Planers, Shapers

Drills, Bolt and Gear Cutters, Milling Machines. Special Machinery. E. GOULD & EBERHARDT, Newark, N. J.

Wood-Working Machinery,

Such as Woodworth Planing, Tonguing, and Grooving Machines, Daniel's Planers, Richardson's Patent Improved Tenon Machines, Mortising, Moulding, and Re-Saw Machines, and Wood-Working Machinery generally. Manufactured by WITHERBY, RUGG & RICHARDSON, 23 Salisbury Street, Worcester, Mass. (Shop formerly occupied by R. BALL & CO.)

\$1200 Salary. Salesmen wanted to sell our Staple Goods to dealers. No peddling. Expenses paid. Permanent employment. Address S. A. GRANT & CO., 2, 4, 6 & 8 Home St., Cincinnati, O.



DUK'S PATENT DUC'S ELEVATOR BUCKET,

For use in Flour Mills, Grain Elevators, Sugar Refineries, etc. Made of Charcoal Stamping Iron, extra strong and durable. No corners to catch. Many thousands in use.

T. F. ROWLAND, Sole Manufacturer, Brooklyn, N. Y.

SPLendid FLOWERS

Strong Plants, your choice, delivered by mail free of cost at your door. Our New Hand-Book of 24 years' experience sent free, with directions for culture of over 1200 best varieties. Centennial medal. Largest assortment. Low prices. All labeled. Satisfaction assured. G. ROSEN, all named \$1; 13 for \$2. HOOVER, BROOKER & THOMAS, Cherry Hill Nurseries, West Chester, Pa.

BETON CONCRETE IN ARCHITECTURE

and Engineering, with 20 illustrations. Beton Bridge; Erie R. R. Portage Viaduct repaired with Beton; Beton Dwellings and Fountain, Brooklyn, N. Y.; Beton Church; Beton Culvert Lining, Erie R. R.; Beton Arches; Church Trajectory, &c.; Beton-lined Railway Tunnels; Beton Pavements; Crushing Strength of Beton; Superior Strength of Beton Arches, etc. Contained in SCIENTIFIC AMERICAN SUPPLEMENT, No. 118. Price 10 cents. To be had at this office and of all newsdealers.

Solid Emery Wheels, Automatic Knife Grinders & Lathe Chucks, of our own manufacture. Medals & Diplomas by Cent' Com'n. Am. Inst., Mass. C. M. A. Am. Twist Drill Co., Woonsocket, R. I.

BONE MILLS.

The best in the world. 5 sizes, adapted perfectly for Crushing and Grinding Minerals and all hard substances. Grinding surfaces quickly and cheaply renewed. Send for descriptive pamphlet.

BAUGH & SONS, PHILADELPHIA, PA.

CODY PAT. SHAFT OILERS, OIL FEEDER & Ad. CINCINNATI BRASS WORKS

STEEL NAME STAMPS 15 CTS. PER LETTER, POST paid. STEEL STAMP WORKS, New Haven, Conn.

65 MIXED CARDS, with name, 10c. and stamp. Agent's outfit, 10c. L. C. COE & CO., Bristol, Ct.

HOLLOW SPINDLE LATHE.

Two sizes: 15 in., 1 1/2 in. hole; 18 in., 1 1/2 in. hole. Besides the most approved features of modern New England Tools, it has many new points of value, making it the best lathe ever offered for general use.

HILL, CLARKE & CO., Machinery, Boston

NEW ROAD LOCOMOTIVES, BY Marshall, Sons & Co. General description and one engraving. SUPPLEMENT No. 56. 10 cents.

Baker Rotary Pressure Blower.

(FORCED BLAST) Warranted superior to any other.

WILBRAHAM BROS. 2318 Frankford Ave. PHILADELPHIA.

\$2500 a year. Agents wanted everywhere. Business strictly legitimate. Particulars free Address J. WORTH & Co., St. Louis, Mo.

PATENTS SOLD.

For terms, address EUROPEAN and UNITED STATES PATENT EXCHANGE, 200 Broadway, N. Y. Box 2801.

LOFTS TO LET, WITH STEAM POWER.

Two Lofts, 35x175 ft. each; light on both sides and ends, with elevator, yard and stable room. Desirable location; all the conveniences adapted to any manufacturing purposes where good light is required. Apply on the premises.

GEO. W. READ & CO., 200 Lewis St., foot 5th & 6th Sts., E. R.

MEDAL & PREMIUM AWARDED TO TURBINE WATER WHEELS MANUFACT'D AT MOUNT HOLLY N. J.

MARK Your Linen with Clark's Indelible Pencils. Sold at all stationers.

BAILEY'S PATENT Hydrants & Street Washers.

The best and cheapest in the market. Plumbers send for circular and prices to

Bailey, Farrell & Co., Manufacturers of Water, Gas & Steam Goods. PITTSBURG, PA.

THE SCIENCE OF LIFE, OR, SELF-PRESERVATION.

Two hundredth edition, revised and enlarged. Just published. It is a standard medical work, the best in the English language, written by a physician of great experience, to whom was awarded a gold and jeweled medal by the National Medical Association. It contains beautiful and very expensive steel plate engravings, and more than 50 valuable prescriptions for all forms of prevailing diseases, the result of many years of extensive and successful practice. 300 pages, bound in French cloth; price only \$1, sent by mail. The London Lancet says: "No person should be without this valuable book. The author is a noble benefactor." An illustrated sample sent to all on receipt of 6 cents for postage. Address DR. W. H. PARKER, 4 Bulfinch St., Boston. The author may be consulted on all diseases requiring skill and experience.

FIRST & PRYBIL, MACHINISTS, And Manufacturers of Wood Working Machinery, 461, 463, 465 & 467 West 40th St., New York, Corner 10th Avenue. Shaftings, Pulleys, Hangers, &c., of the latest improved styles. Send for circular.

RUBBER TYPE! Cases of 125 movable letters, etc., with printing apparatus, \$1.50 by mail; sample of Type and circular, 6c. Address RUBBER TYPE CO., Mallet Creek, Ohio.

PATENT MINERAL WOOL.

Incombustible. The best non-conductor. For illustrated description see SCIENTIFIC AMERICAN of January 12th. A. D. ELBERS, 26 1/2 Broadway, N. Y. P. O. Box 4461.

Advertisements.

Inside Page, each insertion --- 75 cents a line.
Back Page, each insertion --- \$1.00 a line.
(About eight words to a line.)
Engravings may head advertisements at the same rate per line, by measurement, as the letter press. Advertisements must be received at publication office as early as Thursday morning to appear in next issue.

MARVIN'S
FIRE & BURGLAR
SAFES
COUNTER PLATFORM WAGON & TRACK
SCALES
MARVIN SAFE & SCALE CO.
265 BROADWAY, N. Y.

Small Printing Presses!

For amateur and business uses, \$5 to \$100. Do your own printing or advertising and save money. Large illustrated catalogue, 5c.
KELSEY & CO., M'rs, Meriden, Conn.



IN THE OFFICE,
Library,
SITTING ROOM
OR
Academy.
PRICE,
FROM
\$6 to \$20.

Address M. P. HIGGINS,
Superintendent of the Washburn Mchn. Shop,
Send for circular. WORCESTER, MASS.

25 NEW YEAR CARDS, with name, 20c. 25
Extra Mixed, 10c. Geo. I. Reed & Co., Nassau, N. Y.

FOOT POWER TENONING MACHINES FOR SALE
By S. C. HILLS, 78 Chambers St., New York.

THERMOMETERS At Reduced Prices.
Glasses, Telescopes, Microscopes, Spectacles,
R. & J. BECK,
921 Chestnut St., Philadelphia.

An assortment of
WOOD-WORKING MACHINERY
made by Richards, London & Kelley (dissolved); also, a
number of first-class MACHINE TOOLS (nearly as
good as new) of Philadelphia construction, on hand and
for sale. For list or inspection of machines and esti-
mates, apply at the works of JOHN RICHARDS & CO.,
22d and Wood Sts., Philadelphia, manufacturers of
Standard Gauges and other Implements.

THE ART OF MARBLING ON PAPER.
By C. W. WOOLNUGH. How it is done. What pre-
vents the mingling of the colors. Kinds of mullage
used. Action of the Gail. Practical Directions. An
operation beautiful in its simplicity, and instructive as
exhibiting the action of a natural law. Contained in
SCIENTIFIC AMERICAN SUPPLEMENT No. 119. Price
10 cents. To be had at this office and of all newsdealers.

RUPTURE BAND, worn night \$2.50.
Circular and measurement-blank in plain sealed
envelope on application.
L. F. DE LESDERNER, 357 6th St., Brooklyn, N. Y.

Randolph's New Ditcher.
Reversible, Double Ender. Doing work
of sixty men, by horse power, at cost
of six! Steam Machines, costing less
than \$10 per day, to run, doing from
\$100 to \$140 work. Circulars from
RANDOLPH BROS.,
111 Broadway, New York.

**WILSON'S NEW YORK CITY
COPARTNERSHIP DIRECTORY.**
1878-1879. Vol. XXVI.

Containing the names of all copartnerships, special and
otherwise, obtained from reliable sources, neatly com-
piled and arranged in alphabetical order, just from the
press, is now ready for delivery. Very useful to Law-
yers, Bankers, Merchants, and others. Price \$2, and
will be sent by mail, postpaid, on receipt of price.
Address orders to
THE TROW CITY DIRECTORY CO.,
11 University Place, New York.
In preparation: WILSON'S BUSINESS DIRECTORY,
Vol. XXXI, for 1878-9.

NEW UNITED STATES GOVERNMENT
Rules in Respect to Boilers, Boiler Inspection, Stamp-
ing and Testing of Boiler Plates, Fire Apparatus, and
Boat Lowering Devices and Life Preservers. Instruc-
tions to Inspectors, and Tests of Boiler Material are to
be made and recorded. Requirements in Construction of
Boilers. The Law in full, with List of Approved Fire
Extinguishing, Life Saving, and Boat-lowering Appa-
ratus. Contained in SCIENTIFIC AMERICAN SUPPLEMENT
No. 113. Price 10 cents. To be had at this office and
of all newsdealers.



**YALE
IRON WORKS,**
New Haven, Conn.,
Builders of the YALE VERTICAL,
the best and most economical
either for land or marine use. En-
gines and boilers combined. HOR-
ZONTALS, with or without the
Rider Cut-off. The Yale Vertical
Mill, Iron Frame, French Burr,
has no superior in the world.
Send for Circular.

Steel Castings,
From 1/4 to 10,000 lbs. weight, true to pattern. An invalu-
able substitute for forgings, or for malleable iron cast-
ings requiring great strength. Send for circular and
price list to CHESTER STEEL CASTING COMPANY,
EVELINA STREET, PHILADELPHIA, PA.

From 20 to 40 per cent. of custom-
ary outlays for Paints, Roofing,
etc., can be saved.

Send for Samples and Reduced Price-List.

H. W. JOHNS'
ASBESTOS
LIQUID PAINTS.

PURE, UNDILUTED PAINTS. FULL BODY
AND FULL U. S. STANDARD MEASURE.
No other paints for structural purposes equal these
in richness and purity of color, covering capacity, and
durability. Sixteen newest shades and standard colors.
Sample cards free by mail.
ROOF PAINT—For Tin Roofs, Iron Work, &c.
FIREPROOF PAINT—For inside woodwork.

ASBESTOS ROOFING,
With WHITE FIREPROOF COATING.

This well-known Roofing is now in use in all parts
of the world, and is the only reliable substitute for tin.
It is suitable for steep or flat roofs in all climates, and
forms the coolest and most durable portable roofing in
use. In rolls ready for use; easily applied by any one.

Asbestos Boiler Coverings.
**ASBESTOS CEMENT FELTING AND AIR
CHAMBER COVERINGS.**

The most durable, effective, and economical appli-
cances known for preventing radiation of heat from hot
air and steam pipes, boilers, and other heated surfaces.
Ready for use; easily applied.

**ASBESTOS BOARDS FOR GASKETS, STEAM PACK-
ING, SHEATHINGS, COATINGS, CEMENTS, &c.**
Samples, Illustrated Pamphlets, Price-Lists, &c., sent
free. Liberal inducements to merchants and large
consumers.

H. W. JOHNS MANUFACTURING CO.,
87 MAIDEN LANE, NEW YORK.

MACHINISTS' TOOLS.
NEW AND IMPROVED PATTERNS.
Send for new illustrated catalogue.

Lathes, Planers, Drills, &c.
NEW HAVEN MANUFACTURING CO.,
New Haven, Conn.

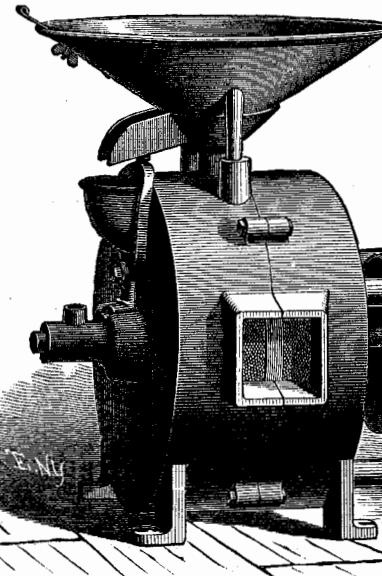

**Harrison's Newly Improved
LIGHT STANDARD 20 INCH
Grinding Mill**
Made at New Haven, Conn.
Grinding Capacity
per hour,
6 to 40 Bushels.
Send for
Illust'ed Catalogue.
Address
W. A. Foskett,
Administrator.

Harrison's System of Grinding!

Illustrated Catalogue Now Ready.
NEW STANDARD FLOURING MILLS.
Old Theories, Horizontal Grinders, Slow Runners,
Fully Exploded. Fine Flour, High Speed, and Econo-
mical Milling Fully Established.
A NEW COPY FOR ALL.
Millers and Editors please address
EDWARD HARRISON,
No. 135 Howard Ave. New Haven, Conn.



WIRE ROPE
Address JOHN A. ROEBLING'S SONS, Manufactur-
ers, Trenton, N. J., or 117 Liberty Street, New York.
Wheels and Rope for conveying power long distances.
Send for circular.

ESTABLISHED 1844.
JOSEPH C. TODD,

(Formerly of Todd & Rafferty), ENGINEER and MACHIN-
IST. Flax, Hemp, Jute, Rope, Oakum, and Bagging
Machinery, Steam Engines, Boilers, etc. I also man-
ufacture Baxter's New Portable Engine of 1877, of one
horse power, complete for \$125; can be seen in operation at
my store. I will furnish specifications and estimates
for all kinds of machinery. Send for descriptive circular
and price. Address

J. C. TODD,
10 Barclay St., New York, or Paterson, N. J.

WARRANTED THE BEST.
1 H. P. Boiler & Engine, \$150.
2 H. P., \$175. 3 H. P., \$200.
Tested to 200 lbs. Steam.
LOVEGROVE & CO.,
125 N. 4th St., Philadelphia, Pa.,
Builders of Engines and Boilers, 1 to 100
horse power. Send for circulars and
prices, and state size and style you want.

**PERFECT
NEWSPAPER FILE**

The Koch Patent File, for preserving newspapers,
magazines, and pamphlets, has been recently improved
and price reduced. Subscribers to the SCIENTIFIC AME-
RICAN and SCIENTIFIC AMERICAN SUPPLEMENT can be
supplied for the low price of \$1.50 by mail, or \$1.25 at the
office of this paper. Heavy board sides; inscription
"SCIENTIFIC AMERICAN" in gilt. Necessary for
every one who wishes to preserve the paper.
Address

MUNN & CO.,
Publishers SCIENTIFIC AMERICAN.

Cut Brass Gears, list free. Grant, 34 Beverly St., Boston.

**WATSON'S NON CHANGEABLE GAP LATHE HAS FOR WORK JAMES WATSON
GREAT FACILITIES FOR LARGE OR MEDIUM MANUFACTURING PA. U.S.**

TO ADVERTISERS! We will send free to all ap-
licants who do any newspaper advertising, the THIRD EDITION OF
AYER & SON'S MANUAL
FOR ADVERTISERS. 150 Pages. More complete
than any which have preceded it. Gives the names,
circulation, and advertising rates of several thousand
newspapers in the United States and Canada, and
contains more information of value to an advertiser
than can be found in any other publication. All lists
have been carefully revised, and where practicable
prices have been reduced. The special offers are
numerous and unusually advantageous. Be sure to
send for it before spending any money in newspaper
advertising. Address N. W. AYER & SON,
ADVERTISING AGENTS, Times Building, Philadelphia.

Pyrometers. For showing heat of
Boiler Flues, Superheated Steam, Hot Blast Pipes,
&c.
HENRY W. BULKLEY, Sole Manufacturer.
149 Broadway, N. Y.

ICE AT \$1.00 PER TON.
The PICTET ARTIFICIAL ICE CO.,
LIMITED,
Room 51, Coal and Iron Exchange, P. O. Box 3083, N. Y.

PARIS EXPOSITION.
The undersigned, American Bankers and Commission
Agents in Paris for twenty-five years, offer their services
to exhibitors for representation and negotiations.
JAMES W. TUCKER & CO., 3 and 5 Rue Scribe.

WESTON DYNAMO-ELECTRIC MACHINE CO

Machines for Electro-plating, Electrotyping, Electric
Light, etc., in addition to testimonials in our Catalogue
of Jan. 1. We beg to refer to the following houses:
MERIDEN BRITAINIA CO.; RUSSELL & ERWIN M'F'G CO.;
REED & BARTON; HALL, ELTON & CO.; RICHARDSON,
ROYNTON & CO.; WM. H. JACKSON & CO.; STANLEY
WORKS; ROGERS CUTLERY CO.; CHAS. ROGERS BROS.;
EDWARD MILLER CO.; MITCHELL, VANCE & CO.; NOR-
WALK LOCK CO.; HAYDEN, GRE & CO.; DOMESTIC
SEWING MACHINE CO.; EBERHARD FABER; JOS. DIXON
CRUCIBLE CO.; MUMFORD & HANSON; FAGAN & SON,
and over 200 others. Outfits for NICKEL, SILVER,
BRONZE, Plating, etc. The two highest CENTENNIAL
AWARDS, and the CENTENNIAL GOLD MEDAL of American
Institute. Prices from \$125 to \$500.

CONDIT, HANSON & VAN WINKLE
Sole Agents NEWARK, N. J.

THE TANITE CO.,
STROUDSBURG, PA.
EMERY WHEELS AND GRINDERS.
GEO. PLACE, 121 Chambers St., New York Agent.

**ADVERTISERS SELDOM
FAIL TO
MAKE
MONEY**
When their advertising is properly placed.
For list of best mediums, address
EDWIN ALDEN'S ADVERTISING
AGENCY,
174 ELM STREET, CINCINNATI, O.
Best rates in the best papers.
Send for catalogue. Estimates and information free.

**DAMPER REGULATORS BEST AND WEIGHTED
GAUGE COCKS.**
MURRILL & KEIZER, 44 HOLLIDAY ST., BALTIMORE.

**ROCK DRILLING MACHINES
AND
AIR COMPRESSORS.**
MANUFACTURED BY **BURLEIGH ROCK DRILL CO.**
SEND FOR PAMPHLET. FITCHBURG MASS.

Mill Stones and Corn Mills.
We make Burr Millstones, Portable Mills, Smut Ma-
chines, Packers, Mill Picks, Water Wheels, Pulleys, and
Gearing, specially adapted to Flour Mills. Send for
catalogue.
J. T. NOYE & SON, Buffalo, N. Y.

**HARTFORD
STEAM BOILER
Inspection & Insurance
COMPANY.**
W. B. FRANKLIN V. Pres't. J. M. ALLEN, Pres't.
J. B. PIERCE, Sec'y.

MACHINISTS' TOOLS
Best quality at low prices. Radial Drills, Engine Lathes,
Iron Planers, Car Wheel Bore, Hydrostatic Presses,
Axle Lathes.
NILES TOOL WORKS, Hamilton, Ohio.

THORNTON'S ADJUSTABLE PIPE TONGS CHEAPEST	DEALERS IN TOOLS WILL FIND THESE TONGS SELL AT SIGHT. TAKING MOST SIZES FOR LEAST MONEY. ADDRESS, PANCOAST & MAULE, 245 SO. THIRD ST., PHILADA.	AND BEST MADE SEND TO MAKERS FOR PRICES.
--	--	---

H. R. WORTHINGTON,
239 BROADWAY, NEW YORK.
Hydraulic Works, Van Brunt Street, Brooklyn,
Manufactures Pumping Engines for Water Works. In
daily use at 100 stations. Also Steam Pumps, Water
Motors and Water Meters. See SCIENTIFIC AMERICAN
SUPPLEMENT, January 27th, 1877. Prices largely reduced
July 1st, 1877.

**THE
Scientific American.**
The Most Popular Scientific Paper in the World.
THIRTY-THIRD YEAR.
Only \$3.20 a Year including Postage. Weekly.
52 Numbers a Year.

This widely circulated and splendidly illustrated
paper is published weekly. Every number contains six-
teen pages of useful information, and a large number of
original engravings of new inventions and discoveries,
representing Engineering Works, Steam Machinery,
New Inventions, Novelties in Mechanics, Manufactures,
Chemistry, Electricity, Telegraphy, Photography, Archi-
tecture, Agriculture, Horticulture, Natural History, etc.
All Classes of Readers find in THE SCIENTIFIC
AMERICAN a popular resume of the best scientific in-
formation of the day; and it is the aim of the publishers
to present it in an attractive form, avoiding as much as
possible abstruse terms. To every intelligent mind,
this journal affords a constant supply of instructive
reading. It is promotive of knowledge and progress in
every community where it circulates.

Terms of Subscription.—One copy of THE SCIENTIFIC
AMERICAN will be sent for one year—52 numbers—
postage prepaid, to any subscriber in the United States
or Canada, on receipt of three dollars and twenty
cents by the publishers; six months, \$1.60; three
months, \$1.00.

Clubs.—One extra copy of THE SCIENTIFIC AMERI-
CAN will be supplied gratis for every club of five subscribers
at \$3.20 each; additional copies at same proportionate
rate. Postage prepaid.

One copy of THE SCIENTIFIC AMERICAN and one copy
of THE SCIENTIFIC AMERICAN SUPPLEMENT will be sent
for one year, postage prepaid, to any subscriber in the
United States or Canada, on receipt of seven dollars by
the publishers.

The safest way to remit is by Postal Order, Draft, or
Express. Money carefully placed inside of envelopes,
securely sealed, and correctly addressed, seldom goes
astray, but is at the sender's risk. Address all letters
and make all orders, drafts, etc., payable to

MUNN & CO.,
37 Park Row, New York.

The Postal Union.—Under the facilities of the
Postal Union, the SCIENTIFIC AMERICAN is now sent by
post direct from New York, with regularity, to subscrib-
ers in Great Britain, India, Australia, and all other
British colonies; to France, Austria, Belgium, Germany,
Russia, and all other European States; Japan, Brazil,
Mexico, and all States of Central and South America.
Terms, when sent to foreign countries, Canada excepted,
\$4, gold, for SCIENTIFIC AMERICAN, 1 year; \$9, gold, for
both SCIENTIFIC AMERICAN and SUPPLEMENT for 1
year. This includes postage, which we pay. Remit by
postal order or draft to order of Munn & Co., 37 Park
Row, New York.

THE "Scientific American" is printed with CHAS.
ENEU JOHNSON & CO.'S INK. Tenth and Lomb-
ard Sts., Philadelphia, and 59 Gold St., New York.

**TO INVENTORS
AND MANUFACTURERS**

FOLLOWS & BATE, Manchester, England, Hardware
and Machinery Merchants, are prepared to buy Ameri-
can Goods for Cash, and to act as Sole Wholesale Agents.

PUNCHING Drop Hammers and Dies, for work-
ing Metals, &c. **THE STILES &
PARKER PRESS CO.,** Middletown,
Conn.

**CAMERON
Steam Pumps**
For Mines, Blast Furnaces, Rolling
Mills, Oil Refineries, Boiler
Feeders, &c.
For Illustrated Catalogue and Reduced Price List send to
Works, Foot East 23d St., New York.

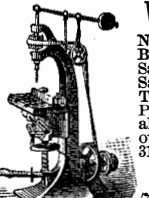

WOOD-WORKING MACHINERY,
New and improved, for special work.
Boring Machines, Turning Lathes,
Saw Arbors, Saw Benches, Scroll
Saws, Panel Raisers, and other Wood
Tools. We build the only patented
Panel Raiser, with vertical spindles,
all others being infringements on
our patents of July 11 and October
31, 1871.
WALKER BROS.,
73 and 75 Laurel St., Phila.

Working Models
And Experimental Machinery, Metal or Wood, made to
order by J. F. WERNER, 62 Centre St., N. Y.

PORTLAND CEMENT.
ROMAN & KEENE'S. For Walks, Cisterns, Founda-
tions, Stables, Cellars, Bridges, Reservoirs, Breweries, etc.
Remit 10 cents for Practical Treatise on Cements.
S. L. MEICHAUNT & Co., 53 Broadway, New York.

**IMPORTANT FOR ALL CORPORATIONS AND
MAN'G CONCERNS.**—**Buerk's Watch-
man's Time Detector,** capable of accurately con-
trolling the motion of a watchman or patrolman at the
different stations of his beat. Send for circular.
J. E. BUERK, P. O. Box 979, Boston, Mass.
N. B.—The suit against Imhaeuser & Co., of New York,
was decided in my favor, June 30, 1874. A fine was
assessed against them Nov. 11, 1876, for selling contrary
to the order of the court. Persons buying or using
clocks infringing on my patent will be dealt with ac-
cording to law.