

Scientific American.

THE ADVOCATE OF INDUSTRY, AND JOURNAL OF SCIENTIFIC, MECHANICAL AND OTHER IMPROVEMENTS.

VOLUME 6.]

NEW-YORK, NOVEMBER 9, 1850.

[NUMBER 8.

THE
Scientific American,
CIRCULATION 16,000.

PUBLISHED WEEKLY

At 123 Fulton street, N. Y., (Sun Building,) and
13 Court street, Boston, Mass.

BY MUNN & COMPANY,

The Principal Office being at New York.

A. T. Hetchkiss, Boston.
Geo. Dexter & Bro., New York City.
Stokes & Bro., Philadelphia.
Barlow, Payne & Parken, London.

Responsible Agents may also be found in all the
principal cities and towns in the United States.

TERMS---\$2 a-year---\$1 in advance and the
remainder in 6 months.

Rail-Road News.

The Railway Monarch's Star again in the
Ascendant.

It is whispered about, that overtures have been made to Mr. Hudson to induce him to come forward and lend the assistance of his energy and experience towards retrieving the affairs of a certain railway company whose dividends have pretty nearly disappeared since the "reform" directors have occupied the position he once filled. We do not pretend to know the fact, but we have some reason to surmise that the honorable member would only consent to meet such overtures in a favorable spirit upon condition of receiving some preliminary *amende honorable* for the unqualified abuse and slander which have been heaped upon him by former friends, and dealt with as if proved. In this the honorable member is certainly right. We must also, whilst referring to *ou dits*, add, it is reported that more than one great railway corporation will be glad to see Mr. Hudson among them. There is also some talk of Mr. Hudson taking an active interest in the management of one newly-opened line, but of course such matters are only to be looked upon as rumors. One thing, however, is pretty certain, that Mr. Hudson's retirement from railway affairs has been severely felt in more than one quarter, and is beginning to excite a feeling of regret.—[Railway Record.

[The above relates to Mr. Hudson, who was almost hooted out of society last year, by public opinion in England, for what was termed "infamous railroad swindling."

The Compound Railroad Iron.

The Baltimore Patriot says, we published a notice on Thursday, of the specimen of a continuous railroad iron, which is now on exhibition at the Mechanics' Fair. It was manufactured at the Mount Savage Iron Company's Works, in Allegheny county, for whom Messrs. E. Pratt & Brothers, of this city, are agents. It is a decided improvement on the usual rail, and is fast coming into general use. The Mount Savage Works, are, we understand, now engaged on a contract for 1000 tons, ordered by the Utica and Schenectady Railroad, in New York, which they ordered after a trial of twelve months of the rail on a short distance on their road, which they laid to test it. It is now being received and forwarded from the Baltimore and Ohio Railroad Company's wharfs, Locust Point. Some 700 tons have already gone forward. It makes a continuous rail by breaking the joints and hence it is not liable to the great difficulty that attends the common T rail and other patterns, which give way where the two rails join. It also allows a greater speed over the road, with equal safety and more ease, and with less wear and tear to the cars.

A Modern physiologist notes the extraordinary fact, that at the dinner table, every time a man crooks his elbow his mouth opens. Can anybody explain this phenomena.

STEWART'S ROTARY STEAM ENGINE.

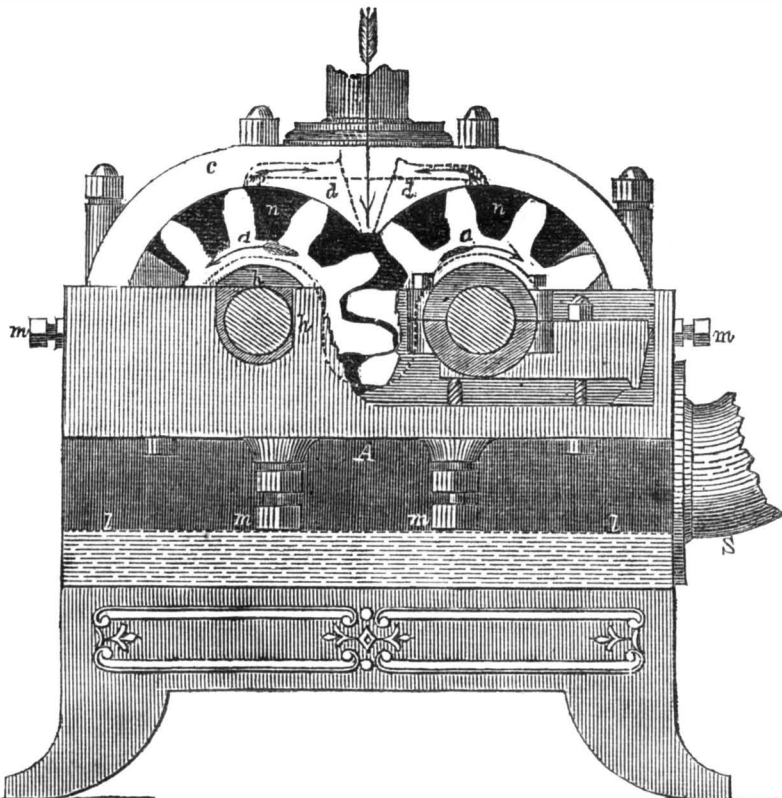

This is the rotary steam engine, invented by Mr. Stewart, of Nashville, Tenn., and described on page 43, in a communication from Mr. F. R. Delano. With the accompanying engraving and description, together with the communication referred to, a full and correct idea of its nature, construction and operation will be obtained.

The above drawing represents an engine of twenty horse power. In operating with this engine, the steam is admitted in the direction of the perpendicular arrow, between a pair of cogwheels, and is confined there by the cap pieces, c, and two cheek pieces, d, which embrace the upper portions of said wheels, steam tight; so that it cannot escape except by

driving the wheels in the direction of the arrows, a a. In its passage out from under the cap, the same steam can be taken from the spaces, n n n, in the direction of the arrows, and thence conveyed to another engine, and applied a second time, by which the maximum effect of its expansive force is obtained. The wheels are kept in their places by means of perpendicular and horizontal setscrews, m m m, and by stationary guides, h h. The box, A, in which the wheels are placed, serves for a heater by filling it with water to the dotted line, l l, and S, is the escape pipe through which the steam passes off.

There will be a few more remarks about this engine next week.

Wilders Leeway Indicator.
FIG. 1. FIG. 2.

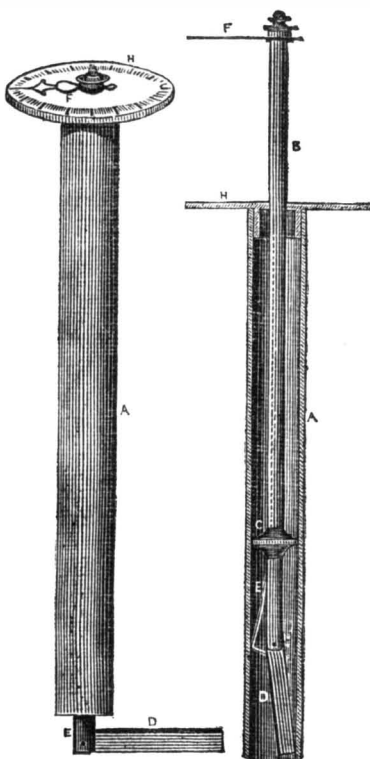

This is the invention noticed by us two weeks ago, as that of Mr. J. Wilder, of Detroit, Michigan, who has applied for a patent

for the same. A is a tube or pipe made of wood or metal, secured in a proper place on the quarter-deck by a flange at the top, and extending down to the outside of the keel of the vessel, and in the interior of this is arranged and connected the machinery attached to a vane below, to move a pointer above and indicate the leeway.

Figure 1 is a perspective view, and figure 2 is a vertical view, showing the interior and how the vane can be drawn up when the vessel comes into port, or for any other purpose. The same letters refer to like parts. A is the pipe spoken of; B is a piston rod, it passes down through the dial plate, H, and works in a collar of the said plate, so as to be moved around; on this rod is a piston, C, to fit snugly in the pipe, to make the rod work steady; E is a spring secured to the bottom of the piston, C, and abutting against the vane, D, to keep the vane in its horizontal position below, when the vessel is sailing; but which allows the vane to be drawn up, (as it is attached by a pivot joint to the rod B) when a considerable power is applied to it for that purpose. F is a pointer attached to the top of the rod, B, and according as the re-action of the water, by the drift of the vessel, acts upon the vane, D, to turn it out of the parallel line with the keel, so will the indicator point out the real, not the apparent, direction of the vessel. The vane, D, is set on a line with the keel, so as to be affected by the side tow only. With respect to its practical action and use

on vessels, we have not any particular account in our possession at present. It will take some experience and many trials to graduate the working parts so as to arrange the size, tension, &c., into a system applicable to all vessels, and also for working, especially in seas where there are currents, like the gulf stream. Whatever information is received shall be duly laid before our readers. This illustration and description cannot fail to direct attention to the importance of the invention; and more information may be obtained by letter addressed to Mr. Wilder, at Detroit.

The Principle on which Plants are Propagated by Cuttings.

The propagation of plants by cuttings is an operation of frequent use, and of considerable importance in all horticultural establishments. The many thousand plants that are annually propagated to embellish flower-gardens and pleasure grounds, and the taste displayed in the arrangement of colors, demand the greatest skill, vigilance, and forethought to prepare, to arrange, and to provide for the display.

The conditions necessary for the propagation of plants by cuttings are, a certain portion of organised matter, the assistance of leaves, a degree of heat and moisture accordant with the nature of the plant, and free drainage at the roots.

When the ascending sap reaches the leaves, the water is discharged through the minute invisible pores, and by the decomposition of carbonic acid gas, which separates to carbon, and sets the oxygen free, a vital action is performed, by which the sap is changed into the organic matter, or descending sap. It is then that all parts of the plant are supplied with a store of organised matter, which renders the parts fit to be employed as cuttings. When removed from the parent, that store, under proper management, will enable them to put forth roots and new leaves, and develop all the parts required for the growth of the plant. If the shoots are in a rapid state of growth, full of rising sap, their tissues lax and not matured, failures may be expected to attend all attempts to propagate them by cuttings.

The next part of the subject is to inquire in what manner the leaves retained on the cuttings assist the protrusion of roots, and the development of other leaves.

As the removal of the cuttings from the parent branch will make no change in the nature of the sap, which is always more or less in circulation in the whole system of the plant, and it is the office of the proper juice to descend in the cuttings to the joint at which it was cut; when its downward course is impeded, it accumulates there until a callous is formed, and roots are protuded; the organised matter of the cutting is diminished to supply the development of roots, and leaves are required to secrete more, to replace that which was expended in the formation of roots. It is when there is sufficient organised matter in the cutting to supply the roots, without exhausting its own vital energies, that the external assistance derived from the leaves may not be needed.

The London Times of the 12th instant, states that a steamer has arrived at that port from Russia, with eighty-nine packages of goods intended for the great Industrial Exhibition. Another lot of goods, equally as large, was daily expected from the same country.

The new pavement on the Boulevards, Paris, has been found to answer admirably; it is free from mud in rainy weather, and from dust in dry weather. It consists of small stones which are besmeared with cold bitumen and oil.

Miscellaneous.

Fair of the American Institute.

The following is part of the list of silver medals awarded,—the diplomas we will not be able to find room for.

SILVER MEDALS.—Utica Globe Mills, Utica, N. Y.—for second best Black Broadcloth.

J. & R. H. Hotchkiss, Hotchkissville, Conn.—for second best Plain Cassimeres.

Hall & Springfield, Rochester, N. H.—for second best Blankets

Mott, Stanton & Swan, New York—for second best Fancy Cassimeres.

Robt. Rennie, Lodi, N. J.—for best printed Cashmeres.

Wm. Duncan & Son, Franklin, Essex Co. N. J.—for second best Shawls.

Dorastus Kellogg, Skaneateles, N. Y.—do.—no difference being perceptible to the Judges.

C. Moses & Co., Skaneateles, N. Y.—the same.

Joseph Dean & Son, Newark, Del.—for Merino Jeans.

Eithert & Stevens, Ware, Mass.—for White and Scarlet Flannels.

Wm. Duncan & Son, Franklin, N. J.—for Piano Covers.

Wamsutta Mills, New Bedford, Mass.—for Bleached Cotton Goods.

Williamsville Manufacturing Co., Rhode Island—for best Brown Shirtings.

Lonsdale Co., Providence, R. I.—for best Twilled Silesias and Black Umbrella Cloth.

Hope Co., Providence, R. I.—for the best Plain Silesia.

Glasgow Manufacturing Co., South Hadley Falls, Mass.—for best Gingham and Gala Plaid Lindseys.

R. Marshall, Troy, N. Y.—for Chambrays, beautiful colors and superior fabrics.

R. Garsed & Brothers, Frankfort, Pa.—for Bed-ticks.

John N. Genin, 214 Broadway—for the best Moleskin Hat.

C. Knox, New York—for best Children's Fancy Hat.

Francis Landry, New York—for second best Furs and Sleigh Robes.

Miss Leggett, Saratoga Co.—for best Dam Muff and Tippet.

Wittmer, Carmell & Co., Philadelphia—for best Printed Silk Handkerchief.

R. Rennie, Lodi, N. J.—for Printed Foulard Silk.

E. R. Gurley, Mansfield, Conn.—for Silk Twist.

J. Hutchinson, Green Point, L. I.—for the best Sewing Silk.

Mrs. C. Van Epps, Ovid, Seneca Co., N. Y.—for the best Cocoons.

A. & E. S. Higgins & Co., N. Y.—for best three-ply Carpets.

A. & E. S. Higgins & Co. New York—for the best Rug.

John D. Wickersham, New York—for Wire Railing.

W. Davis & Co., New York—for best Table Oil Cloth.

Henry Gritten, New York—for best Carved and Gilded Frame.

Wm. M. Thompson, New York—for best specimen of Gilding Stamps.

Moore & Browning, New York—for Inlaid Pearl Papier Mache Tables.

Archer & Warner, Philadelphia—for second best Lamps, Chandeliers and Girandoles.

Hayward Rubber Co., Colchester Conn.—For best India Rubber Shoes, and considered a remarkable improvement on former years.

Dr. G. S. Browne, Hartford, Conn.—for best Abdominal Supporter and Fjody Brace.

Yerger & Ord, Philadelphia—for the second best Artificial Leg.

S. N. Marsh, New York—for second best Spring Truss.

E. Waters, Troy, N. Y.—for best Breast Pump.

Hugh Cattin, Brooklyn—for best Diatonic and Piccioli Flute.

C. G. Christman, New York—for fine Brass Instruments, Clarinet and Hautboy.

Clyde Glass Works—for Window Shades of

superior surface, color and uncommon thickness.

George W. James, Brooklyn—for best Boat, "Jenny Lind."

Bean & Breidenbah, New York—for best Sign Painting.

J. & J. C. Conroy, New York—for best Fishing Tackle, Rods, Reels, &c.

Thomas Finegan, New York—for best Artificial Flies.

Henry Smith, Paterson, N. J.—for best Imitation of Wood.

H. Goulet, New York—for best Imitation of Marble.

Burger & Walker, New York—for second best specimens of Cut, Plain and Colored Glass.

Porter & Fairchild, New York, superior brushes.

Steele & Co., New York, best feather brushes.

Massachusetts Arms Company, Chicopee Falls, Mass., second best revolving pistols.

D. Fish, New York, second best rifle.

Crittenden & Tibbets, Coventry, Conn., percussion caps.

Leroux & Villot, New York, best castings.

Edward Phalon, New York, gentlemen's wigs and toupees.

R. H. Richardson, Massachusetts, best bonnet.

Beaver & Perry, Brooklyn, L. I., best gilt and velvet paper hangings.

A. H. Wheeler, New York, best specimen of penmanship.

Croney & Lent, New York, best men's clothing.

Ellis & Iselton, New York, best children's clothing.

D. M. Knight, New York, best gilt buttons.

C. Beardsley, New York, best top wagon.

James Flynn, New York, best wagon without top.

J. C. Thornton, Columbia, S. C., buggy wagon.

J. C. Ostrand, Rhinebeck, superior sleigh.

William Sayre, Newark, N. J., best child's carriage.

John L. Allen, New Haven, improvement in elevating and lowering carriage tops.

Benjamin Benson, Smyrna, Del., tilting or dumping wagon.

John Wild Jr., New York, second best pen and pocket cutlery.

John Garside, Newark, N. J., handles on table cutlery.

J. R. Gamble & Brother, Philadelphia, superior morocco.

W. G. Broadwell, Newark, N. J., sheep and lamb skins.

Wm. Abendroth & Brothers, New York, second best cooking stove.

R. B. Thompson, Brooklyn, L. I., best cooking stove with water centre.

J. R. & E. N. Hyde, New York, best cooking stove with hot air furnace.

B. P. Learned & Thatcher, Albany, New York, best parlor cooking stove.

Philip Rollhaus, New York, second best kitchen range.

Wm. Cobb, New York, large hotel range.

Baker, & Duyekinck, New York, best blank book.

John P. Burnton, New York, blank binding.

Carson & Brothers, Dalton, Massachusetts, best writing paper.

Edwin Allen, South Windham, Conn., new article of type for the blind.

A. G. Fay, Concord, N. H., best lead pencils.

George E. Waring, Stamford, Conn., second best hot air furnaces.

Chilson, Allen & Walker & Co., Boston, Mass., best parlor stove.

Elihu Smith, Albany, N. Y., second best do.

B. Rodriguez, New Orleans, hot air oven and cooking combined.

F. Grote, New York, best ivory turning and carving.

Frederick Kiddle, New York, workmanship on duplex escapement clocks.

Friderick Kiddle, New York, improved eight day watch.

A. D. Crane, Newark N. J., astronomical year clock.

An Impostor Inventor.

The following is from a recent London paper. We extract it in its length and breadth for the benefit of our readers. We scarcely believe that any Yankee merchant could be so gulled, but it is difficult to tell, for there are simple men of business in every country, and we have heard of such a character, as the impostor herein described, playing pranks of a kindred nature in New York:

"At Guildhall, on Friday, John Stevenson, alias Wilson, alias Price, alias Johnson, alias Williams, a respectably dressed, gentlemanly looking man, described as usher to a school, was charged before Alderman Sidney with obtaining various sums of money from different well-known firms in London, under the following curious and interesting circumstances:—Mr. William A. Rose, oil merchant, 66 Upper Thames street, said he knew the prisoner, who called on him in May last, and brought a sample of naphtha, saying he had discovered it in his efforts to effect a colored daguerreotype. He added he was ignorant of the value of the article, and wished witness's opinion on it. He said it could be made at an expense of about 2d or 3d per gallon from common saw dust, by the aid of electricity. (Laughter.) Witness told him the market price of the article of the same quality was from 8s. to 9s. per gallon, when he proposed that witness should join in carrying out the invention on a large scale, and share the profits. He would require money to get the apparatus, and proposed witness should advance it, saying he would construct it at his own house, and bring it complete to witness's premises. Negotiations were pending between them for some weeks, and at length the prisoner sent a man with four sheets of zinc and a handle apparently intended to form part of the apparatus for making the naphtha with. The bearer produced a short note, requesting witness to pay the party presenting it the following order:—"Received of Mr. William Anderson Rose the sum of £9 17s. 6d. for goods received of Charles Wilson." The note was signed "George Johnson for John Jones." Witness paid the party the money, who gave him a stamped receipt for it signed as above. Witness had previously gone to £6 expense for portions of the apparatus. The four zinc plates were worth about 5d., and the handle, when applied to any machinery, was not worth more than 2s. The second case was then heard:—Mr. Joseph S. Edwards, in partnership with his brother as millers and corn merchants, in the Blackfriars Road, said the prisoner called on them about the first of June, 1849, and said he was an amateur chemist, and told witness that from some experiments he had made in chemistry he had produced a kind of white powder, which he showed him a sample of, and asked what it was, and if they could tell what it was prepared from. Witness said he thought it was a gum of a very glutinous nature. It seemed like a small quantity of powdered gum. Prisoner said he could produce it, at an expense of 20s. per cwt. from mangel wurzel. He left a sample with witness, who promised to try and find some one who would likely dispose of it in large quantities. Two or three days after he called again, and they entered into negotiations with him for the manufacture of this article, as it appeared to be a very valuable discovery. Believing his representations, witness on the 9th of June, 1849, let him have £15, for which he gave witness a stamped receipt, signed "Charles Williams." On the 12th of the same month he sent witness a note, requesting him to pay the bearer, Mr. Price, £9. The man who came with the note, gave witness a receipt for the money, signed "John Price." He had not seen the prisoner since until he was in custody. He thought at the time that the discovery was worth from 50s. to 60s. per cwt. Mr. Webster Flockton, of the firm of Flockton, Brothers, oil merchants, of Horselydown, proved a similar case against the prisoner to the last, he having on the month of May, 1848, represented to them that he had discovered a process of making oil of turpentine from water and sawdust, at an expense of 4d. per gallon, and he obtained in the name of

"Charles Williams," £15 for the purchase of

the necessary apparatus for producing it in a large way. The prisoner was then remanded on these three charges.

[Taking the whole of the above into consideration, it is one of the richest jokes of the season. Only just think of a fellow making a respectable London merchant believe that he could make naphtha out of water and sawdust by electricity, for 6 cents per gallon; why it's enough to drive old Deacon Dakin's cow a fox hunting.)

Esquimaux Theory of the Heavenly Bodies.

Their theory regarding the sun and moon is rather peculiar. It is said that, many years ago, not long after the creation of this world, there was a mighty conjuror (Esquimaux, of course) who gained so much power, that at last he raised himself into the heavens, taking with him his sister (a beautiful girl) and a fire. To the latter he added great quantities of fuel, which thus formed the sun. For some time he and his sister lived in great harmony, but at last they disagreed, and he, in addition to maltreating the lady in many ways, at last scorched one side of her face. She suffered patiently all sorts of indignities, but the spoiling of her beauty was not to be borne; she, therefore, ran away from him and formed the moon, and continues so until this day. Her brother is still in chase of her, but although he sometimes gets near, he will never overtake her. When it is new moon, the burnt side of the face is towards us; when full moon, the reverse is the case.

The Largest Merchant Ship in the World.

A ship is about to be built in this city, by W. H. Webb, of 230 feet in length, 42 breadth of beam, 25½ depth of hold, and clipper built, she will be 25 feet longer than any merchant vessel sailing from this port. All the principal pieces are to be of live oak, and, what is altogether novel in the construction of American merchantmen, a system of iron lattice-work, or diagonal iron bracing, is to be introduced, with a view to secure the greatest practicable degree of strength. She is to be finished in about six months, and will run from New York to Canton, via California, and thence home, completing the circuit of the globe with each trip. She will measure near 2,600 tons.

A Yankee.

The best definition of the Yankee, we have ever seen, is the one attributed to "an Eastern lecturer," who said that it would not be a very violent stretch of the imagination to believe that a thoughtful Massachusetts or Connecticut baby, six months old, sits in its mother's lap, eying his own cradle, to see if he could not invent a better, or at least suggest some improvement.

We would extend the definition to the whole universal Yankee nation, which we understand is somewhat extensive now in this considerable patch of the world, now known as Uncle Sam's corn field.

Peter Deshong.

The Toronto (C. W.) Globe states that Peter Deshong, the arithmetician, died of apoplexy on the night of the 9th inst., while on his passage from Kingston to Toronto, in a steamboat. He had been lecturing to audiences in Quebec, on a new and short system of computing figures, which he stated he had discovered, and which we know he had a copyright of, and sold it for \$10. He made us a present of one, which was to enable us to multiply and divide whole columns in a twinkling. His rules worked very well with his printed tables, but whether it was owing to the opaqueness of our vision or not, we cannot tell, but somehow or other we could never make his rules work with other tables of figures. A very good wood engraving of Mr. Deshong will be found on page 6, Volume 3, Scientific American. Mr. Deshong was a native of Lancaster, Pa., and is stated to be 35 years of age.

In London under the patronage of the Lady Mayoress, a large carpet is in progress of preparation for the Exhibition. It is to be 30 feet in length, 20 in width, and to consist of 150 squares.

For the Scientific American.

The Voltaic Battery.—Precipitation of Metals.

NUMBER V.—(Continued.)

Being now provided with a battery, we may proceed to make the solution of gold:—Into a well glazed bowl or large tumbler, put one pint of rain water, and dissolve in it one ounce of cyanide of potassium; hammer out a five dollar piece to extend the surface, and solder a wire to the edge; connect to the silver end of the battery of four pairs; let the gold be placed at the bottom of the solution of cyanide, and let a wire from the zinc end of the battery dip into the solution for half an inch. In a few hours a black sponge will gather round this wire, which will indicate that a considerable portion of the gold has been dissolved. The operation may now be ended, but it will be better to continue it until at least half the gold is dissolved.

The method of making a solution as given above, is far more cleanly expeditious, and inexpensive than by first reducing the gold to oxide, but as it looks to having the gold in a plate, and it may sometimes be desirable to use fragments and old jewelry, we must first dissolve the metal in nitro-muriatic acid; this will be a troublesome process, for the alloy in the coin or jewelry coats the pieces with an insoluble chloride; generally the process can be greatly expedited by first alloying the gold largely with zinc, the resulting mass will be vigorously acted on by nitric acid, which will dissolve all the base metals or reduce them to oxide and leave the gold and silver as a fine sediment, which subsides after the action has ceased, when the fluid may be poured off and the sediment washed. The nitro-muriatic acid will readily dissolve the gold in this comminuted state and form chloride with the silver, which, being insoluble, can be easily separated from the acid solution of gold. The gold solution should now be slowly evaporated at a gentle heat until it solidifies on cooling, when it must be dissolved in water, and a solution of cyanide of potassium should be gradually added until the yellow color of the chloride of gold disappears. This may be used direct for gilding, but it will perform better after freeing it from the chlorine, as follows:—Dilute sulphuric acid is to be added to the solution until the brown cyanide of gold ceases to fall down, after which the precipitate may be washed and dissolved by adding a solution of cyanide of potassium. We will now have a pure solution, which will give a deposit of pure gold, but gold, when pure, does not look as well as when alloyed with some copper; a small quantity of cyanide of copper should be added to give a red tinge to the gilded article. Cyanide of copper is easily made by adding cyanide of potassium to a solution of sulphate of copper, the cyanide of copper will subside, when it may be washed and dissolved with cyanide of potassium.

The next process in order will be to clean the watch case: silver articles are easily cleaned by putting them for a few hours in soft soap, and after well brushing with chalk and laid in a weak solution of cyanide of potassium for a few minutes, then well rinsed in hot water and connected to the zinc end of the battery and immersed in the gold solution; from the silver end of the battery there should be a piece of gold, which should be as far removed from the watch as the vessel will allow. If the solution has been made by the first method, the residue of the coin will answer for the piece from the silver end; this piece is generally called the solvent pole. As the gold is precipitated on the watch this pole will be dissolved proportionate to its size: if larger than the article receiving the deposit, more gold will be dissolved than deposited; but if much less in size, then more will be deposited than dissolved.

Only a synopsis of the process of gilding is now given, for there are many particulars which will equally apply to silvering, and can be more forcibly brought to the attention when we are treating of silvering or electroplating, which is a difficult process, while gilding has but one obstacle, which we will now consider:—After the watch case has been under the battery influence for a few mo-

ments it will appear of the ordinary color of gold, but in five minutes or so, most likely it will look as if it had been smoked over a lamp—here is the difficulty: the gold, instead of going down with its metallic hue, goes down as a black powder. This is what is called the "black deposit," and in the early applications of electro-gilding it was thought to be insuperable; but a few moments' consideration will show the cause of this blacking, and having once comprehended the cause, the difficulty can be easily obviated. When the case is first immersed in the solution it comes in contact with the cyanide of gold and potassium, in a few moments the battery will secrete all the gold from the solution in immediate contact with the case, and leave the case enveloped in cyanide of potassium; this stratum of cyanide of potassium commingles with the other portions of the solution, and thus brings more gold in contact with the case, and this gold is quickly deposited, and the cyanide of potassium again envelopes the case. If the battery urges the gold faster than it can be brought to the case, the gold will be precipitated on the envelope of water and cyanide of potassium; that this is the true cause of black deposit, may be made evident by taking the case from the bath and thoroughly cleaning off the black gold with a stiff brush and chalk, and again exposing it to the battery action and briskly agitating the solution; while the gilding is going on the agitation will carry the cyanide of potassium from the case as fast as deprived of its gold, and keep the cyanide of gold and potassium in contact with the case. If we keep up the agitation it will be much longer than at first before the black deposit appears, or most likely it will not appear at all. It is now evident that the battery was too strong for the quantity of gold in the solution.

(To be Continued.)

Foreign Correspondence.

RESPONSIBILITY OF CAPTAINS, OVERSEERS, &C. GLASGOW, Oct. 18, 1850.

Since I wrote to you last, several affairs have occurred here which may have a special interest for some of your readers. The tragedy of the Orion, in the Scotch waters, has been repeated by the Superb, trading between France and the Channel islands; twenty lives were lost. The captain and chief officer were held to bail in £100 (too small I think,) to stand their trial. Their conduct seems to have been extremely bad: but the point to which I would direct your attention is this—the steamer was taken into dangerous waters from mere curiosity, to show the passengers the wreck of another steamer. The tide in the channel runs, I think, forty feet, which, on one side of the Atlantic, is deemed a high rise at any part of the coast. She struck a rock, stuck there, and was suspended on the recession of the waters. The crew and passengers all got off in boats: but the boats had plugged openings, and the plugs were lost again! So they filled, capsized and sunk. One man swam for three hours, but we can't all swim so long, and those who could not swim at all were drowned. You are inclined to say, I have no doubt, what is quite true, that, 1st, slides would answer all the purposes of plugs in boats—would never be out of the way, and any person could shove them in with the heel or toe of his boot. 2nd, That when people are immersed, a cork pillow, which may be packed into a portmanteau, or a light cork jacket, would support them. 3rd, That water-proof, or cork pillows or mattresses, would cost little more than those in common use, and are useful from their resistance to all "verminage," which are more annoying, I should think, in your Western States, than with us. But can you say why these ordinary precautions are not adopted?

The overseers of a coal pit, in which eighteen to twenty lives were lost a few months since, in this neighborhood, were tried at the Criminal Court a few days ago. One was acquitted not guilty, the other dismissed "not proven." The difference is peculiar to Scotch law—the first settles the case for ever; the second verdict leaves the accused party open to another trial, if more evidence be found. The charge against them was negligence in ventilating their mine.

I find here a great neglect or deficiency in proper fog signals for railways. In consequence ten or twelve lives were recently lost on the Eastern Counties, English line. We have fog signals, but they seem to be troublesome and are often neglected. Could you not help the world to something cheap and easily arranged?

We have no news here. Politics are as still as a bug in a storm: nothing moves. The next eruption will be a commercial question—currency, reciprocity, and so on. The Chancellor of the Exchequer has a large balance in his favor, and is paying off "the debt" therewith. But it will take a "long while's" practice ere we feel the difference.

The French are likely to afford some excitement by-and-bye: their President wants to be Emperor, and as a step, to get elected for ten years. He will be successful in the first move.

Trade here is duller within a week than I have observed it for some time. I cannot ascribe any particular cause. Iron is selling (pigs) here, good brands, mixed Nos., for 42s. 6d; State 45s. to be the average price of production. Cotton goods are evidently not paying the makers, from the high price of cotton. Regarding this matter, I have already told you that great exertions are being made to increase the cultivation on the African coast, of which we have just bought a large slice from the Danes; in Hindostan, in the West Indies, and, I may now add, that some splendid samples of cotton are to land from Australia, which seems the most prosperous part of the world at present.

Several large screw steamers are building for the trade from this country to Cape Town, South Africa. The line will probably be soon extended to Australia. Screw steamers are, I can see, in great demand. The Clyde builders are all pre-occupied.

The City of Glasgow steamer was sold for £40,000 to the Liverpool and Philadelphia line of screws, which is largely owned in Glasgow. She will be succeeded by large vessels on this line next year. The Cunard Line of steamers is owned in Glasgow, although sailing to Liverpool, to the extent of five-eighths or three-fourths. A line is proposed to St. Johns, Newfoundland, thence to Quebec, and from the small quantity of coals required at once on board, will probably pay.

The accounts from the expeditions in search of Sir John Franklin's ships and men are unsatisfactory. Vestiges have been found which plainly show that they were once encamped not far from the entrance to Prince Regent's Inlet, but why, whether from necessity or in taking observations, does not appear. I do not expect that they will ever be recovered; and I hope that these absurd efforts to find a northern passage, that must be valueless, are past. We have spent more money on them than would have half sufficed to run a line of rails from Halifax to Van Couver's Island, which is one proper North-west passage—taking us to Australia without being once out of a temperate region. * *

Booth's Patent for the Reduction of Gold.

The nature of my invention consists in the preparation of a solution of gold alloyed with silver or other metals, so as to convert them into chlorides; and a precipitation of metallic gold upon the chloride of silver and other insoluble chlorides, and in the subsequent reduction and extraction of the silver or other metals from the insoluble chlorides, or the direct extraction of their chlorides, by solution, in the manner hereinafter set forth, so as to leave the gold pure. To enable others to make and use my invention, I will proceed to describe the manner of conducting the process and its operation.

First, I make a solution of gold, containing silver and other metals, so as to convert them into chlorides.

Second, I precipitate gold in the metallic state from the solution so that it mixes with undissolved chloride of silver and other insoluble chlorides.

Third, I dissolve out the chloride of silver and other insoluble chlorides from the gold by means of a special menstrum herein described, or I reduce the chloride of silver and other in-

soluble chlorides, to metals, by zinc or iron and sulphuric or muriatic acid, and dissolve out the metals reduced from their insoluble chlorides from the gold by nitric or sulphuric acid. The process for making the solution is thus: to one part, by weight, of granulated gold, that is, gold melted and cast into water, I take about one part of common salt about three-fourths, or about three-fourths of one part of nitrate of potassa, or one-half of one part of nitrate of soda, and about one and a half parts of oil of vitriol; I put the salts and gold into a wooden vessel, to be presently described, and covering them with water, I admit steam into the liquid until it attains a boiling heat. The wooden vessel may be any ordinary vessel or vat made with staves, or otherwise, of any convenient size, the best proportion for which is a depth as great, or greater, than its diameter, having about one-fourth of the cover fastened on the top and provided with a wooden trough passing into a chimney or other flue, and the test of the cover moveable so as to charge or empty the vat more conveniently. The object of the trough is to carry off any fumes that might arise to annoy the operator during the process, although little or none can arise except steam. Instead of the arrangement of the cover and trough here indicated, the vat or a series of them may be set into a horizontal flue which is connected with a chimney and the vat or vats covered loosely with boards during the process. A stout piece of wood bored through its entire length and open at each end is secured vertically to the inner side of the vat and a steam pipe or tube passed into the upper opening. The steam admitted through the tube, passes down through the wooden pipe, and escapes freely into the liquid, heating it to any temperature required for the process. When the water is sufficiently heated, the oil of vitriol previously diluted with several parts of water is added by degrees in successive portions, according as I observe the action to progress. The gradual addition of sulphuric acid generates muriatic and nitric acids or their elements slowly so that they spend their full force upon the gold without escaping, thus preventing any annoyance to the operator from injurious vapors, while at the same time their more powerful nascent is employed in effecting combination and solution. I thus continue the addition of sulphuric acid, and the admission of steam, say for three or four hours, or until all or nearly all the gold is dissolved. The solution will then contain per chloride of gold and the sulphate of soda—or sulphate of soda and potassa while chloride of silver and other insoluble chlorides will remain undissolved and if the process shall be conducted too hastily, also a small amount of gold.

Sulphates or chlorides of other metals if present, are also insoluble. The advantages of the above method of solution are the use of cheap materials avoiding the cost of previously preparing muriatic or nitric acid. Cheapness in the use of vessels of wood in which solution or combination is effected. The use of steam for heating which is safe, economical and under control and when blown directly into the liquid, also prompts solution by agitation. The gradual development of the acids with its attendant advantages as previously mentioned.

The precipitate is thus: the precipitation of metallic gold is effected in the same manner in which the solution is produced and may be performed as soon as the solution is completed.

For the above proportion of gold, say one part, I employ about five parts of crystallized copperas, which I prefer putting into the liquid gradually in the state of powder, although it may be dissolved in water and poured in, and continue the application of heat by blowing in steam until all the precipitant has been added, occasionally pouring in a little muriatic or sulphuric acid to prevent the precipitation of the peroxide of iron or a basic salt of the peroxide. In this way the whole of the gold will be precipitated in the metallic state as a fine powder, which a continuance of heat will collect into a closer and more compact precipitate.

(To be Continued.)

New Inventions.

Improvement in Apparatus for Drying Cloth in Printworks.

Mr. Nathan Buchanan, of Providence, R. I., has invented a new improvement for drying cloth in calico printworks, which is of no little importance in this branch of the arts. In what are termed "blotching stove rooms," calico cloth, in a certain stage of preparation, is submitted to a most intense heat to dry the mordant very rapidly; this is done in a hot, still atmosphere. The improvement is to dry the cloth in an active hot atmosphere, by a peculiarly constructed chamber, heated by hot air driven in by a blower. The cloth passes up (the pieces being connected together) over rollers, and is dried in a very rapid and even manner, at one revolution, of what may be termed "a chain of pieces." The invention also embraces the drying of pieces in a current of the atmosphere, the chamber being so constructed as to open a flaring-mouthed slide at the bottom, which tapers into the chamber, and which, when opened to the breeze, causes a partial vacuum in the top of the chamber, by the air being condensed in it, thereby creating in a very simple manner without any machinery being employed, an artificial current of air to dry the cloth in a very short space of time.

The Iron Twin Steamer—An Old Concern.

The London Morning Post contains rather a glowing account of a new iron steamer built and fitted out according to a patent granted to Mr. Peter Borrie, for improvements in the construction of double-hulled or twin vessels. Mr. Borrie is a Scotch engineer from Dundee, and we are sorry to see a practical man engaged in re-vamping Symington's old boat, described in the last volume of the Scientific American. The hulls were chiefly constructed of iron and placed side by side, with a space or canal between them, in which the paddle-wheel works, and are strongly connected together by the deck (which extends over all,) and also by a plate arch below the deck, and a number of wrought-iron stays between them, so that the two divisions of the vessel are bound together in the most secure manner.

This steamer is named the Gemini, and the Post says that "twin steamers are extensively employed in river navigation in the United States, and they are occasionally to be met with in this country." This, however, is a great mistake—no such vessels are employed in America. The Gemini, as might have been foreseen, has proved itself to be a "dead shot," having made very bad time on the Thames. A vessel of this kind was once erected in New York by an engineer, and it could do every thing but sail well. We remember well what it was to do before it was completed, and we remember very well what it did not do, after it was completed. It is not to be expected that engineers know the best form of vessels, nor carpenters the best kind of engines.

Improved Lathe Chuck.

Mr. Thomas Harding, of Rochester, N. Y., has taken measures to secure a patent for an improvement in concentric chucks, which is a very simple and good one, we believe. There are four setting screws, on which the jaws are secured in the usual way, but there is a bevel pinion on each screw pin, which works into a bevel geared ring inside, so that by turning any one screw the whole of the jaws move in unison to, or from the centre.

Improvement in Quilted Cloth.

Mr. Thomas Francis, of this city, has taken measures to secure a patent for a new kind of manufacture of quilted cloth, whereby raw cotton is embraced between two sheets of cloth and secured in stitched stripes—all worked on the weaving loom at one operation, the cloth and the quilting.

More than sixty expeditions have been despatched from England to explore the Arctic regions, from the time of John Cabot and sons, in 1497, to that time of Sir John Franklin, in 1846.

New Locomotive.

A new locomotive recently patented in England, has been tried on the Liverpool and Southport railway and attracted considerable attention. The object of the patentees of the engine was to combine lightness, power, and economy of fuel, and we believe they have succeeded in their aim. The engine, which is named the Spitfire, conveyed a train of carriages from Waterloo-station to Southport at a rate of speed varying from forty to sixty miles an hour, and, when at its highest velocity, manifested no oscillation whatever. The Spit-

fire is a four wheel engine, with fourteen inch cylinders and twenty inch stroke, the driving-wheels being five feet six inches. The working valves and pumps of the engine, which are usually crowded together underneath the boiler, are placed outside the frames, so that for all the purposes of adjustment, cleaning, or repairs, they are as easy of access as similar parts of a fixed engine. On the whole, the trial of the engine gave great satisfaction. It was constructed by Messrs. Forrester, of Vauxhall Foundry.—[Liverpool Albion.

ADKINS' IMPROVED HARVESTER.—Fig. 1.

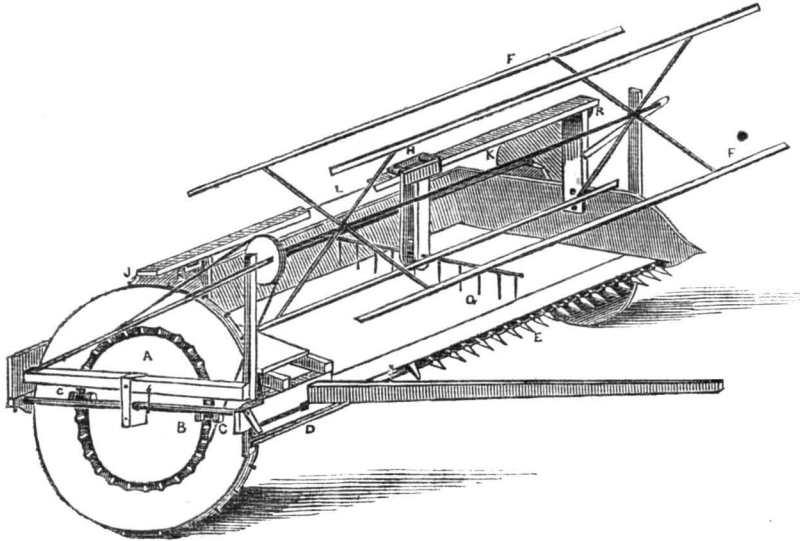

This improvement is the invention of Mr. Homer Adkins, of Plymouth, Hancock Co., Illinois, and for which, as we stated last week, he has taken measures to receive a patent.

Figure 1 is a perspective view, figure 2 is a side inside view showing the master wheel, which operates the rake and gives it a reciprocating intermitting motion. Figure 3 is a front view of the pulleys and a side view of the reciprocating rake. The same letters of reference indicate like parts.

The nature of this improvement consists in having a rake connected with the cutting apparatus, and operated in such a manner as to deposit the cut grain, &c., after it is laid on the floor of the machine, in regular bunches on the ground, in rows, ready for binding. A frame of the carriage is constructed in the usual way, with a pole, D, at any side for the team to draw. A is the master wheel, with

FIG. 2.

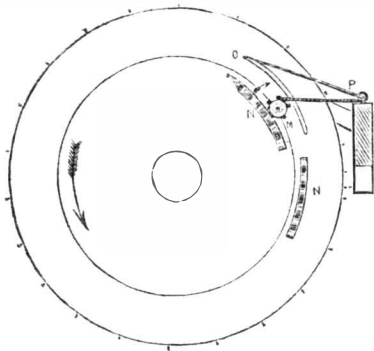

cam projections, on one side of it; these projections strike the arm, C, which is connected with the cutting blade, D, and give it a side to side reciprocating motion, to cut the grain or grass. The teeth, E, gathers in the grain and holds it firm to the action of the scythe. The grain is laid over on a platform when cut, by the revolving reel, F F; this reel bends down the grain on the platform; it receives a rotary motion by a band passing from a pulley on the wheel, A, over a small pulley on the shaft of the said reel. So far the description does not relate to the improvement, Mr. Adkins having already received a patent for the manner of operating the scythe, and which is illustrated on page 12, Vol. 5, Scientific American.

Behind the reel there is a rake, G, placed transversely, to slide forwards and backwards, and push over, or deliver, at the side on the ground, the cut grain. Behind the reel are two uprights with a shaft working in bearings in the same. On the two ends of this shaft are

grooved sheaves, J K. A cord passes over each of these pulleys in opposite directions, in such a way that the cord winds up on the one in one direction, and from the other in the opposite direction; these cords pass over small rollers, R R, and are attached to the slide, H, of the rake, (G, fig. 3.) L is a guide bar of the slide of the rake. The way by which the rake gets motion will be better understood now by paying attention to fig. 2; this figure shows the inside of the master wheel, A, of figure 1. (The pins on the periphery is to give it adhesion on the ground.) On this wheel are two sections of cam cogs, N N, the one placed above the other, and but a short distance apart. M is a pinion on the shaft of the sheaves, J K, and the cord shown is one passing over a sheaf in fig. 3. As the wheel passes round in the direction of the large arrow, the cogs, N, now acting on the pinion, turn it in the direction of the small arrow winding up the cord on the pulley, J, fig. 3, and making the rake, G, slide forward, pushing outward at the side the cut grain, or grass, in a bunch. Then, when the other cogs, N, take on to the other side of the pinion, they turn it in a contrary direction, the cord is gathered up on the pulley, K, and the slide of the rake is pushed back

FIG. 3.

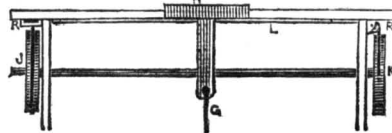

to await until the cogs, N, of the wheel come round again to make the rake deliver the cut grain or grass, as set forth. The cogs, N, are so set on the wheel as to make the rake act once during one revolution—one revolution of the wheel being allowed to cut about the right quantity to make a bunch for binding. The wheel might be made to make the rake deliver two bunches as well as one, or even more. The rake is so attached to the arm in which it is hung, by a joint, that it moves stiffly forward, but turns up so as not to disturb the next cut of grain, while moving back. This is done by a bar in the rake arm, which prevents the rake from swinging back when moving forwards, but allows it to swing when it is moving back. P (fig. 2) is a pall which prevents the pinion, M, from turning back. It is now represented as being lifted by a curved cam, O, to allow the cogs to act on the pinion, M. This pall is attached to the back part of the machine, and of course cannot be more represented in fig. 2.

We have thus explained the construction

and action of this machine, and our farmers, as well as machinists, will get a correct idea of the same.

Mr. Adkins' machines are in operation in Illinois, giving good satisfaction. More information may be obtained by addressing him at Plymouth, as mentioned above.

Useful Hints.

TO TIN AND SOLDER IRON.—Iron can be tinned in two ways,—one by the old method of cleaning the iron well and dipping it in molten tin; another, for small jobs, by cleaning the iron well, dipping it in a solution of the chloride of zinc and then dipping it in molten tin. Two pieces of plate iron may be soldered together in the common way of soldering tin, by first cleaning the edges either by a file or sand paper, then by the feather of a quill washing the edges with the chloride of zinc, putting them together and soldering in the usual way. We have seen plates of iron soldered this way with great rapidity. The chloride of zinc is made by dissolving clean pieces of the sheet metal in muriatic acid; feed in the zinc until the acid stops effervescing. This liquid should be kept in every machine shop. After the joint is soldered it should be washed in some water in which soda or common wood ashes have been dissolved: this is to neutralize any free acid that may be about the joint. It should at last be washed by a little warm water.

TO WASH ENGRAVERS' PLATES.—Engravers on copper and steel have frequent trouble, after having etched their designs, to find free acid working underneath, and also in the clogging up of the etched lines with the oxide formed with the nitric acid and the metal; two years ago an eminent engraver, of our city, had considerable trouble from the causes mentioned, and having asked our advice about it, we told him to wash his plates in warm water. He did so, and since that time he has never had any trouble with them. The reason why warm water is superior to cold, is owing to some oxides being insoluble in cold water, and perfectly soluble in warm water. Some free acids also combine, with some difficulty, along with cold water, but are freely taken up with water.

Sea Sickness.

M. Currie, recently, in a paper read before the Paris Academy, has pointed out the cause of sea-sickness. He has shown that it depends upon the movement of the intestinal canal which floats, as it were, in the abdomen. It descends with every movement of the vessel, and then, ascending, pushes up the stomach and the diaphragm. His theory, well explained, was well received, and Magendie and Keraudien gave their assent to it. But his remedy was thought more ingenious than practicable. It was to breathe in with every downward movement of the vessel, and expire the air with its ascent. What seemed more easy, and is known to be more effectual is a horizontal position in the middle of the ship, and a tight bandage over the abdomen.

It is well known that the latter plan is very effectual to relieve sea-sickness, but it is not a good plan to pursue, after the first sea-sick bout is over. Active exercise, and frequent action on deck, soon drives away sea-sickness, and without this course is pursued, those liable to sea-sickness, need not expect to get over it at all, they are liable to have it during all rough weather.

Aristotle said that man had the largest brain of all animals, in proportion to the size of his body, but modern anatomists say that canary birds far exceed us in proportional weight of brain.

The glass house for the World's Exhibition, next year, goes on nicely. It will contain 400 tons of glass.

Rotary Steam Engine.

We understand an improvement has been made by Geo. F. Woolston, of Orangeburg, S. C., in the rotary steam engine working on the principle of re-action, by causing the arms from which the steam issues to revolve in a vacuum.

Scientific American

NEW YORK, NOVEMBER 9, 1850.

Commissioner of Patents' Report.

Last week we set forth the amendments suggested by the Commissioner, to be made to the Patent Laws. Since that time we have read a letter in the Washington "Republic," and by its tone we would infer that the Report has been the subject of some late hostile attacks. The letter referred to is a very weak production, but somewhat truthful. It is wrong to make uncandid attacks upon any man, or the production of any man, but in reviewing a public document, it is as certainly wrong not to give free and candid expression to opinions, whether favorable or unfavorable to the sentiments expressed in the subject under review.

The Report is the best printed and does more justice to inventors, whose contributions sustain the Patent Office, than any Report previously issued, and we will take pleasure in presenting the substance of the same from time to time, which will be found of great interest to the majority of our readers.

There are four Chief Examiners in the Patent Office; each has charge of a certain department, for the examination of a certain class or classes of subjects: Charles G. Page, M. D., has charge of the department embracing philosophical instruments, such as electric and telegraphic machines, &c.; stoves, &c.; musical instruments; fine arts, embracing painting, maps, drawings, &c., and surgery, embracing all connected with this art and dentistry; and to this is attached a part of manufacturing processes, such as attaching hooks and eyes to cards, and also atmospheric churns, &c. Before the increase of Examiners in the Patent Office, all the subjects were divided between two—Prof. Page and Mr. Fitzgerald. About two years ago, two more Chief Examiners were added to the Office, viz., Mr. Renwick, of New York, and Prof. Gale; the former never was in the Patent Office before his appointment, but the latter was in the capacity of Assistant Examiner under Dr. Page. The classes of subjects are now divided among these four, but they are not yet well arranged: out of twenty-three classes, Examiner Page has seven classes, a synopsis of which, as covering his labors for 1849, we will now present, and take up the reports of the other Examiners regularly in other numbers:—

EXAMINER PAGE'S REPORT.—In 1849 a valuable machine was patented for separating magnetic iron ore by revolving electro magnets: this was Ransom Cook's invention, and was illustrated in the Scientific American. A number of patents were granted for telegraphs, and the famous contest between Morse and Bain was settled, by which a patent was granted to each claimant, and the decision of the Patent Office reversed, as we predicted, and away and behind all this—both of these patents—we can assure the Patent Office that we know something of another chemical telegraph. This case is stated to be the first trial of appeal from the Patent Office, in open court; the whole case has been faithfully reported, and contains a great deal of information useful to inventors. A railway telegraph, to tell the traveller the place he is passing, was patented, and it seems to be identical with the one published in No. 1, Vol. 4, Scientific American, and is now free, we believe. The Calculating Machine, illustrated and described on page 388, same volume, was patented, and the nature of its construction and operation is particularly described in the Report. A patent was granted for measuring distances by observation, and is said to measure a distance of 40 or 50 miles. A patent was granted for a self-igniting lamp, which was lighted by pulling a string, when a friction match, by machinery, was ignited and carried forward to the wick of the lamp.

The most singular case, or rather cases, of all, was a patent which was granted for a species of atmospheric churn, and before the patent was known far beyond the walls of the Patent Office, two other inventors claimed the same improvement; one was from Ohio, an

other from Illinois, and a third from Vermont. An interference was declared, and no sooner was the decision made (which was in favor of the patentee) than three other inventors claimed it,—all living at a distance from one another. The improvement consisted in having a hole through the entire length of the common churn dasher, with a valve opening downwards, to admit air from above, but which would allow no cream to come up from below. A knowledge of this case is important to inventors—all these six men were no doubt original inventors. Whenever an important improvement is made, application should at once be made for the patent, for no secret use of an invention can prevent another man getting a patent for the same thing.

The American Institute.

The name of this Association is a glorious one. To distinguished foreigners, it conveys the idea of being the moral centre of all that is noble and distinguished in American Science and Art; but the name is too good for the faculty who seek shelter for their stunted acquirements beneath the magic of its significance. If any person has the least idea that the American Institute fairly represents American Science and Art, he is greatly, very greatly mistaken. With but three or four exceptions, we think there is not a man who is connected with its management, or who has any influence in its actions, that is the least distinguished in any department of Philosophy or Art. We should indeed feel ashamed of our glorious country if the Institute enfolded all Americans, who were distinguished for scientific and mechanical attainments, or that it was looked upon as the mirror which reflects upon other nations the semblance of American mind. There are many far younger, weaker, and smaller institutions, in our land, whose managing members stand far higher than those of the A. I., in every acquirement which should belong to managing members of such associations.

That the Fairs for the exhibition of works of art and ingenuity do good, no one doubts; but the object of doing good is only secondary, the principal object of the managers being the best way of making the most money, and the easiest way to please all the influential exhibitors. Just look at five gold medals awarded for five planing machines—all first best, too, and then what is the conclusion? Not a very favorable one, surely. That some prizes are rightly awarded, no one will doubt; it would be a miracle were it to happen otherwise; but that a prize granted to one machine, work of art, &c., and not to another, is to be taken as an evidence of the superiority of the one, in all cases, and the inferiority of the other, is all nonsense—no one in New York looks upon the prizes in this light. Trashy things get prizes sometimes, and things of utility and beauty are often overlooked; this is owing to the incapacity of the judges; they listen to the best story—a modest man, however meritorious his invention may be, stands a far worse chance of being distinguished than one who, with "words of wondrous length and thundering, sound, boasts of his ware, his merchandise and skill."

As an advertising medium, the Fair is a good institution, and as such it is to be recommended, but in nothing more, excepting in bringing ingenious men together—men who are mostly outsiders. As for scientific emanations proceeding from the Institute, whoever heard of such things. It may well be said about it what a benighted Hibernian said about a certain dingy lighted city, "one thing is very clear, this town is very dark."

Improved Saw.

Since we noticed an improvement on saws, a few weeks ago, (page 28) Mr. Tuttle has been bored with quite a number of communications on the subject—almost every one claiming to be the original inventor. Not one, however, seems to understand the improvement thoroughly. Mr. Tuttle does not claim his third tooth, as therein mentioned, because it is straight, but because it is a plane. He used the third tooth himself, just like some of his correspondents, some years ago. In every case a correspondent should pay his postage.

Captain Taggart's Propeller Balloon.

On Thursday, last week, we went over to Jersey City to see Capt. Taggart make an ascension in his propeller balloon. The place selected was a very bad one, viz., the dock behind what is termed the "Thatch Cottage." The most contemptible means were employed by hundreds to shirk the payment of the admission fee, and when the time for ascension arrived, we suppose that there were five within the enclosure who had not paid, to one who had. The balloon was not very well managed we think: there was too little hydrogen gas in it, and the attendants did not appear to be well acquainted with their business; and beside this, the crowd was allowed to press close up to the apparatus. At 4 P. M. the captain got into his car, and although it was not quite buoyant enough to lift him freely upwards in a vertical position, yet he thought that by turning one of his guiding wings, he should shoot upwards out of the reach of all ground obstructions. The rope was then cut, and the balloon, with the gallant little Captain in it, went off—but not in the way he desired. The strong south breeze carried him against the little bridge; his propeller wing was broken, and he was dragged through the canal and then against the tall trees of the garden; this arrested its progress, when the Captain got out after some trouble, and a rope being attached to the apparatus, it was dragged from the trees across the bridge by a roaring set of on-lookers, and then (as it appeared to us) the rope designedly parted, when the balloon and broken car went off, up and away, like a rocket—lost to the Captain forever.

Many people in our city, when they saw the balloon passing over them, supposed the Captain to be riding on the clouds, but he was safe on terra firma.

If ever we needed confirmation to our often expressed opinions respecting the impossibility of aerial navigation, according to the present state of science, we need it no more. The Captain's propelling apparatus is the best that we ever saw. If ever we had sympathy for any man, it was for him: we could not get the thought of him out of our mind during the whole of that night. The crowd, the majority of whom neither paid to see, nor had sense to make due allowance for unfortunate circumstances, abused the Captain with their tongues, shamefully.

We have heard that he intends to build another balloon; we hope he will be more successful than with his last. His loss and expenses have been very great, and when we consider that he made two previous ascents in Massachusetts, and that he was totally unacquainted with ballooning before that, he certainly deserves praise for his nerve and enterprise, and we hope the public will not neglect to be generous to him. We don't like humbug inventors—we despised the tricks and exposed the sham of the California balloon in 1849, because it was a project to make money and gull the public, but Captain Taggart is a sincere and an honest-looking man, and a complete enthusiast in the utility of his invention, which we deeply regret, knowing the dangers of his adopted profession, but on that account he surely deserves a greater supply of popular sympathy.

Machinery for Turning Irregular Forms.

MESSRS. EDITORS:—In your paper of Sept. 7th an article was published that proved injurious to me, and I wish you to correct the error. I had made a model of a machine; with a stationary pattern and material:—two of the gentlemen interested in Blanchard's machine called on me, and after an examination of my model, Mr. Lindsley, of Newark, said he had been under the impression that the pattern rotated, but that he never had seen a machine like it. Mr. Howard, of Philadelphia, stated afterwards that he had a conversation with Mr. Lindsley, and was better satisfied than if ten men had given their opinion and that he could not see any part of my machine that interfered with the Blanchard Machine; I never received a notice of a suit as stated by your Philadelphia correspondent, as I never had a machine except the model—but I have since commenced one. I wish you

to examine the model submitted and you will oblige me by publishing the above with your opinion of my machine. JONATHAN RUSSELL, No. 3. Cherry st., Philadelphia.

Oct. 30th, 1850.

[We publish the above in justice to Mr. Russell. The article to which he refers was a communication from Philadelphia. We know nothing about the case only as represented in the communication referred to, and by Mr. Russell's own statement. The model referred to above, has no rotating pattern, nor does the rough material revolve. Two rotary cutters and two tracers are employed, which turn or cut out the form of the pattern on the rough material in sections. The cutters and tracers are set nearly opposite to one another, and move longitudinally along the frame, but only one section of the pattern is cut out on the rough material during one longitudinal movement from end to end, of the cutters and pattern tracers. As a whole, we do not think that it is as good a machine as Mr. Blanchard's, and we cannot see how they can be similar in principle.

Jenny Lind's Concerts at Tripler Hall.

The concerts of Mademoiselle Jenny Lind continue to attract hosts of admirers of the art vocal; we are not surprised at this, for no one, after hearing the sweet strains which flow from her lips—however incapacitated they may be to criticise—can wonder at the generous enthusiasm which attends her whenever she appears.

The new Hall (splendid in design and execution,) is well adapted, in every respect, to give a full and legitimate effect to her voice, and so far her triumph has been sufficiently brilliant to gratify the highest expectations she could have conceived. New laurels have been added to her resplendent fame, by the concerts at Tripler Hall, and to such of our citizens as have not heard her, we would advise them, by all means, to seize upon the present opportunity.

There are, however, a large number of industrious mechanics in this city who are desirous of hearing her, and feel themselves unable to pay the present prices. If we mistake not, Mr. Barnum, with his accustomed liberality, aided by Jenny's whole-souled benevolence, will afford them an opportunity to do so at reduced prices, before she finally leaves us. Castle Garden would hold a number sufficient to pay well at \$1 to all parts of the building.

Fall of a Suspension Bridge.

A suspension bridge built on Dredge's principle, across the river Leven, at Balloch, Scotland, recently fell while a flock of sheep were beginning to pass over it. On examination it was found that the cause of failure was owing to the previous breakage of a small iron rod, only one inch in diameter. One thing singular about it was the dropping of one half of the bridge, and that not the one the sheep were on, but the opposite half. Does this show that, from the abutment, the weight on the bridge acts throughout the whole length of the bridge upon the long end of the lever, and not from the apex of the arch.

An Important Paragraph.

To preclude our subscribing friends the necessity of writing for the back numbers of the Scientific American, we shall forward to all new subscribers the back numbers of Vol. 6, dating their subscriptions from the commencement unless they instruct to the contrary when they remit. We shall pursue this course of sending the back numbers issued on this volume until No. 13, and after that time the names will be entered from the date of the reception of orders, unless the writer expresses a wish to receive the back Nos.—in that case they will be promptly forwarded.

Those desiring volume 5 of the Scientific American are informed that we are able to furnish a few complete volumes, (bound,) at \$2.75 each. Also, we can send by mail sets complete, minus No. 1, for \$2. We would also say, that whenever our friends order numbers they have missed—we shall always send them, if we have them on hand. We make this statement to save much time and trouble, to which we are subjected in replying, when the numbers called for cannot be supplied.

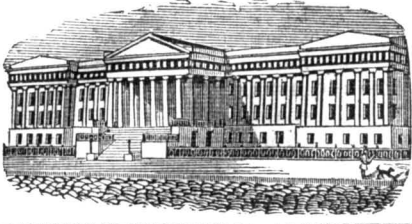

Reported expressly for the Scientific American, from the Patent Office Records.

LIST OF PATENT CLAIMS

Issued from the United States Patent Office. FOR THE WEEK ENDING OCTOBER 29, 1850.

To Bartholomew Bemowski, of London, England, for improvement in Printing. Patented in England Nov. 19, 1846.

First, I claim marking on the shank and foot of types, by any convenient means, such as writing, engraving, casting or electrotyping, the same letter or character which is formed on its upper surface, and also the method herein shown and described, of casting the intaglio letters on the shank and foot of the types at the same time that the type itself is cast.

Second, Making type having in combination with the usual letters in relief on the face of the type, intaglio letters on the foot thereof, for the purpose of serving as matrices from which to obtain a polytype plate, while the types themselves will serve for printing.

Third, I claim casting spaces on the sides of ordinary type for the purposes above mentioned as above described.

Fourth, I claim the peculiar mode herein shown and described, of poly-composing either from the ordinary cases, or from what I call the authoriton.

Fifth, I claim the process and apparatus herein shown and described, for facilitating the sorting and distributing of types and spaces, and making part of them of wood and iron, so that the wooden portion may be separated by means of water, the iron ones by a permanent or temporary magnet and the others into three several receptacles by hand, the workmen being considerably assisted in this operation by the type being marked on their sides.

Sixth, I claim the apparatus which I denominate the "Authoriton," and also of the use of copying-sticks, for the purpose of facilitating composition, by which the above described types are brought into a convenient space for composing from as hereinbefore described.

To C. S. Bulkley, of Macon, Ga., for improvement in Electro Magnetic Enumerators for Signals in Hotels, &c.

I claim the manner in which the signal bell and any one of the signal plates can be simultaneously acted upon at a distance from the enunciator, through the medium of the galvanic battery, the series of electro-magnets, and the four wires connected with each other, with the insulated point and the shank of the knob located within the walls of the different rooms, and with the bell and signal plates of the insulator, substantially in the manner herein set forth.

L. G. Goshon, of Shireleysburgh, Pa., for improvement in Winnowing Machines.

I claim the combination of the additional bottom board with the elevated fan and fan case, for the purpose of diminishing the space between the discharging board and screens, for concentrating the blast beneath and in contact with the screens, for the purpose described.

To Nathan Haskins, of Hillsborough Co., N. H., for improvement in Car Couplings.

I claim the improvement whereby the cars are connected or disengaged under the above named circumstances, or, in other words, I claim the combination of the suspended extension pin, with its weighted pin or arm, or any mechanical equivalent thereof, the hinge and buffer socket to which they are applied, the same being constructed and made to operate substantially as set forth.

To Richard Montgomery, of New York, N. Y., for improvement in Corrugated Boilers.

I claim the employment of corrugated plates of metal for forming the curved arches of fire chambers and shells for steam boilers, the corrugations running in the direction of the curves, substantially as described.

To John Morrison, of McArthurstown, Ohio, for improvement in Bedstead fastenings.

I claim the construction and application of a triangular or forked plate of iron made in such a manner as that it can be secured to its place and draw the rail and post firmly together by means of an eccentric or cam, substantially as above described.

To Dan Pease, of Troy, N. Y., for improvement in Rotary Grain Screens.

I claim the construction of a roller screen consisting of a large and fine, and small and coarse part in combination with conductors to carry the grain from the large to the small part for the above mentioned purpose, and substantially as above described.

To Bennett Potter, Jr., of Templeton, Mass., for improvement in machinery for pressing hats.

I do not claim merely so arranging the smoothing irons that they can all, by a single movement be simultaneously brought over the block, I only claim this when the irons are also at the same time and by the same movement, brought into the requisite contact with the top and sides of the crown and with the brim of the hat, to smooth and compress the same, substantially as herein specified.

I likewise claim the devices herein described or their equivalent for rendering the crown iron self-adjusting with respect to the brim-irons, so that the pressure of the crown iron will be co-terminous with that of the brim-irons without affecting the relative degree of pressure with which they respectively bear upon the surfaces to be smoothed by them, substantially as herein set forth.

To Nathan Starks, of Albany, N. Y., for improvements in machines for making Wrought Iron Car Wheels.

I claim the forging of solid wrought iron wheels, when made by drop and die, the use of a lower die or anvil, made to revolve, during the process of forging horizontally on a central vertical axis, either by hand or by machinery which operates to drop the ram, or hammer, substantially as set forth.

To J. P. Sleeper, of Worcester, Mass., for improvement in Reed Musical Instruments.

I claim the vibration string or strings, wire or wires (four) in their combination with the wind chest, the same being made to be vibrated by the air in its passage in or through the wind chest, substantially as specified.

I also claim the above described extension or elongation of the passage, in combination with the improved arrangement of the reed and valve opening, the said arrangement consisting in placing the reed not directly over the valve opening, but at a distance therefrom, and in said passage, substantially as specified.

To T. J. Sloan, of New York, N. Y., for improvements in machines for nicking the heads of Wood Screws.

I claim interposing a spring between the gripping jaw and the lever or cam by which it is operated, in manner substantially as herein described and for the purpose specified.

I also claim making the spring which is interposed between the gripping jaw and the mechanism which operates it so that its tension can be varied and regulated in the manner and for the purpose specified.

And I also claim causing the gripping jaw to open slightly after it has seized the blank to permit the blank to assume its proper position between the jaws before it is finally gripped, in manner substantially as herein specified.

To H. N. Swift, of Boonton, N. J., for improvements in Spike Machines.

I claim, first, the adjustable cutter when in such position with regard to the dies for holding the spike, that the rod forming the spike is both cut off and the proper bend given to it from the head at one and the same operation, during which the spike is held stationary substantially in the manner described.

Second, I claim the jaw of the swage kept open by a spring, in combination with the moving swage and the stationary swage, the moving swage having an inclined face, which, acting on a similar face on the back of the jaw, closes it for forming the point for the spike, whether placed in front of the revolver, to point the rod, or behind it to point the spike, constructed substantially as described.

DESIGNS.

To Laban Eddy, of Taunton, Mass., for design for Stoves.

To Wm. Ballard, of New York, N. Y., for design for Iron Railings.

What I claim is the posts, panel, and marginal grape vine base in form and design substantially and herein set forth.

For the Scientific American.

Our Manufactures.

It is a settled fact, that the surplus population of the Middle and Northern States must have employment. The mechanic arts in some form must be cultivated, or beggary will ensue. A great part of American capital, industry, and genius can be employed in reference to no other object. In this we follow in the train of other nations: Great Britain no longer manufactures for the world; she finds her competitors across the channel and the Atlantic. Manufactures may be said to be essential to our national independence and security, and contribute to the wealth, comfort, and embellishment of the land. This conviction is made by a consideration of its natural resources, and the enterprise and ingenuity of its inhabitants. An English manufacturer, who came to America to inspect our rising arts, upon examining specimens of mechanic inventions introduced by "the clever Yankees," into a department where his own exertions had been particularly bestowed, declared that the American market was lost to him forever.

It has been supposed that masses of people thus brought together would become nurseries of ignorance and crime. This apprehension has arisen from the acknowledged character of like establishments in England. But happily for our country, even the evils incident to the system have not been felt; the moral debasement found in the workshops of Britain is owing to circumstances which have no connection with the employment: the manufacturing districts there are decidedly more moral than the agricultural. The surplus population is large, and afflicted with oppressive taxes and neglect of morals and education. The structure of our government and our social institutions forbid such a result. No doubt it is a principle that masses are operated upon more easily for good or evil than a scattered population; but English workmen receive their character, not from the manufactures, but from British aristocracy. The leading characteristics of the English system, and chief source of all its evils, is the employment of families, and constitutes a radical distinction between our system and that: the proprietors of Lowell act on the principle, that private interest is best promoted in the long run by general intelligence and public virtue. Many operatives exhibit an extraordinary extent of acquired knowledge, soundness of judgment and refinement of feeling. In regard to the influence of our manufacturing establishments on the social character of the people, the standard of conduct and attainments is higher than in England; the health of our manufacturing villages is equal to that of the country at large; and there is in every class a disposition to rise above their station. "Wealth and a fair character constitute a title in America:" a Yankee never serves but with a view to obtain the means of becoming a master in his turn. Their influence is also favorable to the intellectual character of the people; it is by their improvements in the mechanic arts and their application to manufactures, that Europeans so far surpass other nations. In an eminent degree, then, will our nation be benefitted, since the means of instruction are accessible to all. The many vehicles of intelligence, entering every hamlet, develop talent and impart a taste for knowledge. The walls of a manufactory cannot shut out this light. Their influence on the religious character of our nation is a vital point. Great is the power of example and sympathy in compact bodies of people having a common interest. The Gospel, in its ministrations, has been signally prospered in these crowded resorts, and this principle has been seized upon by good men for the advancement of the best of causes. Many of the heads of our factories are men distinguished as promoters of religion and temperance; and most are convinced that the operation of evangelical piety is favorable to order, diligence and honesty. Large numbers leaving every year car-

ry with them the spirit they have imbibed, and thus scatter the seed of grace far and near. Let, then, these centres of business, as fast as they rise, become each the seat of churches, and a nucleus of a widely extended evangelical influence. The day will come, and we hail the increasing tokens of its approach, when every labor of science shall be an oblation upon the altar of religion. J. W. O.

Shot on Iron Ships---A new Protective.

Some time ago we described some experiments made with shot upon iron ships, in England, when it was found more destructive than on wooden vessels. Since that time a new protective has been tried, and found to succeed admirably. The protective consists of a composition of india rubber and saw dust, invented by a Lieut. Walter, of the navy, and named "Kamptulicon." The experiments were made at Woolwich, on the 4th of last September:

"A target of iron, six feet square, to which the Kamptulicon lining was attached by means of a solution prepared for the purpose, was erected at a distance of forty yards from a 32-pounder. Four shots were fired with the iron surface presented, the third, which fired with a reduced charge, to represent a long range, lodged in the material; and the fourth, which, with still further reduced charge, fell without doing injury at the foot of the target. It was then turned round, with the Kamptulicon lining towards the gun, at which four shots were also fired. The first two passed through with nearly the same effect, opening the iron to a considerable extent, but the lining closed up immediately, so as scarcely to admit the insertion of a small cane at either end, the centre being quite close. The fourth shot, fired with a very reduced charge, rebounded about fifteen yards in a direct line; thus proving that a shot at a long range would not even enter a vessel so lined. It may also be presumed, from the wonderful resistance of the material, and its repellent power, that nothing under a full charge would fire a shot through the two sides. As to its adhesive nature, it occupied a dozen strong men, armed with hammers and crowbars, a considerable time to detach it from the iron after all this battering. In small portions cut from the different targets were seen large pieces of iron imbedded, which might cause frightful wounds and even death, if scattered amongst the crew."

The inventor claims that, from its elasticity, it will "immediately collapse after the passage of a shot, so as to prevent the entrance of water, thus obviating the necessity for plugs;" and that it will "deaden the concussion caused by the striking of shot, or in firing a vessel's own guns, thus protecting the rivet-heads; that from its buoyancy it will keep the vessel afloat, if riddled with shot, or after striking upon rocks, and will enable her to carry a large supply of coals with a smaller draught of water; and that it will prevent the loss of life caused by splinters, by their retention in the Kamptulicon."

Tobacco Culture.

Professor Johnson, in the course of lectures delivered by him, before the New York State Agricultural society, and published by C. M. Saxton, among many valuable facts worth the attention of agriculturists, stated that Tobacco was a crop which contained much mineral matter. Suppose, says Prof. J., an acre to yield 800 lbs.; these 800 lbs. will contain about 160 lbs. of mineral matter, which is carried off by the crop, and in this way the land will soon be exhausted. In four years, 600 lbs. of mineral matter would be carried off from an acre of tobacco land. It is the duty of the farmer to supply the mineral matter, thus specially exhausted, if he wishes to sustain the soil.

Extent and Population of London.

The population of London is 1,924,000, the number of houses 260,000. The average number of inhabitants for each house is 7½—far less than in New York. Opposite Pall Mall 800 carriages pass every hour, and on London Bridge 1,300 every hour; 8,000,000 of horses pass over Westminster Bridge in one year.

TO CORRESPONDENTS.

"M. R., of Ohio."—The best work on the steam engine is Tredgold's. It is now publishing in parts. It is somewhat expensive—but it is complete in all its details.

"A. C., of Conn."—The expense of an application would cost you at least \$55. We would not advise you to apply for an improvement on the ballance valve, there is no probability, we think, of getting a patent. You think that the Electro Magnetic Engine will never supersede the steam one, owing to the acid and zinc being so scarce, so we think, and more expensive too on that very account.

"J. W., of Mass."—You ask us to give the reason why the Pulley Engine of Mr. Yates gains so much power after we have proved that no power was lost by the crank. We have never said that the pulley engine gained either power or leverage. We only stated that it beat the crank. We will thank any body to prove any more than we have done, we only stated facts with respect to its speed on trial. The pulley has broken a number of times since, the patentee says, it is owing to bad workmanship.

"T. A. D., of Ind."—Yours of the 20th ult is received and has been filed for attention whenever your interests may demand. \$1 received and credited.

"H. M., of Vt."—We have ascertained that the machine plate, of the size and quality you require, will cost \$10. You can order it through this office if you prefer.

"B. L., of Geo."—We were obliged to write Messrs. Carter & Harris for information in regard to the corn sheller, but have received no reply. We presume from this fact that they do not wish to dispose of the machines.

"A. C., of Ohio."—We can see no loss by the crank, if others can. The only way to convince the world and us of the superiority of the rotary engine, is to build one and test it fairly in all points, with a reciprocating one. The loss of time which you speak of, is no loss, if the power is not lost.

"E. W., of S. C."—The hydraulic rams could not, that we can see, answer your purpose, for draining. Windmills which are used in Holland, would be far better. Mr. G. Page, of Washington, D. C., constructs windmills that would answer your purpose. We know of no machines to accomplish the drainage of your fields, but the steam engine or windmill.

"W. S. G., of Mass."—Agitators have been used in boilers; we do not believe your plan patentable, although it is no doubt a very good one.

"A. H. S., of La."—We do not believe the story about the air gun, we think precious little of air guns for sporting purposes. We will tell you the price of the rifle, &c., again.

"C. B., of Ohio."—Music bells—a set have long been used in some of the spires in Europe, on which tunes are played at regular periods, the same as we ring bells. Musical glasses are well known. Their music is the sweetest we have ever heard—like what we would attribute to fairies, but glass music bells we have never heard. The musical glasses are tumblers selected in the manner you propose to select for your glass bells. We don't believe they could be patented.

"A. M. G., of Texas."—We are gratified to hear that you are in a way to recover your health. We would be glad to advise you, but we fear to do it as there are so many specifics recommended about which we have no knowledge. You can probably make arrangements with L. M. Wiley & Co., of this city, a well known house, to receive your consignments. They do considerable in this way, and we advise you to write them.

"T. E. R., of N. Y."—The alembic is used for distillation, when the products are too volatile for the use of the retort. Evaporating vessels are made of wood, glass, metal or porcelain. They are generally in the form of shallow basins.

"P. C. R., of Pa."—The progress of water through a pipe is greatly retarded by every deviation from a straight direction, and by every enlargement, contraction, projection, or roughness it meets within its passage, therefore you should make the pipes as straight as possible.

"F. H. & Co., of Tenn."—The names of the subscribers you forwarded are all properly entered on our books, and the papers have been sent as directed. We cannot prevent the papers from being rubbed in the mail.

"J. P. H., of Va."—We believe that Foster & Bailey's rock drill would answer well for coal mining—weshould like to see it tried. The pick and jumper are the only instruments used that we know of. With respect to the salt we do not believe that magnetism could be profitably applied, but it might. Try the galvanic battery, it may precipitate the iron very quickly without depositing the salt. Have you tried newly slacked lime? it is surely better than alum, try it.

"W. O. P., of S. C."—The hydraulic ram could not avail you anything for lifting the water and draining your 150 acres. At the very least it would be a great expense since it must be pumped. A windmill, may answer well, but a steam engine is the most certain. We would choose the latter, but Mr. G. Page, of Washington, constructs very good and cheap windmills.

"B. M. F., of N. Y."—You ask if it is not the common opinion among philosophers, that an increased pressure of the atmosphere facilitates the flow of water. It is not, if you mean rivers and streams. If you mean condensed air pressing on water in an air chamber of a pump, then it is, for the air striving to expand to the common pressure of the atmosphere acts mechanically upon the water, to force it out of the discharge pipe.

"M. H., of Tenn."—Air differs from other fluids in four particulars: 1st, it can be compressed into a much less space than it naturally possesses. 2d, it cannot be congealed or reduced to a solid state. 3d, it is of a different density in every part upwards from the earth's surface, decreasing in its weight as its distance from the earth increases. 4th, its elasticity, or the force with which it springs, is equal to the incumbent weight.

We have several communications on hand awaiting attention. They will receive it as soon as we can reach them.

Money received on account of Patent Office business, since Oct. 30, 1850:—

O. C., of Ohio, \$50; H. B., of Mass., \$30; S. & T., of Pa., \$35; A. G. B., of N. Y., \$25; H. A., of Ill., \$30, and W. & F., of N. Y., \$32.

Patent Claims.

Persons desiring the claims of any invention which has been patented within fourteen years can obtain a copy by addressing a letter to this office; stating the name of the patentee, and the year the patent was granted (adding the month of the year when convenient), and enclosing one dollar as fees for copying.

ADVERTISEMENTS.

Terms of Advertising:

One square of 8 lines, 50 cents for each insertion. " 12 lines, 75 cts., " " 16 lines, \$1.00, " "

Advertisements should not exceed 16 lines, and cuts cannot be inserted in connection with them for any price.

TIN PLATE AND SHEET IRON WORKERS.—ROY'S & WILCOX, Mattabessett Works, East Berlin Station, on the Middletown Rail Road, manufacture all kinds of Tools and Machines of the best quality, both in material and workmanship. This establishment being the only one where both tools and machines are manufactured, superior inducements are offered to the trade; all work warranted, with fair use. Agents in most of the principal cities of the United States and Canada. Orders promptly attended to. F. ROYS, E. WILCOX. Berlin, Conn., Nov. 1, 1850. 71amly

UNITED PATENT OFFICE IN PARIS AND LONDON.—GARDISSAL & CO., 29 Boulevard St. Martin, Paris, and No. 9 Arthur st. west, city, London. Patents procured in Great Britain and on the Continent: "Le Brevet d'Invention," weekly journal, published by the same firm. 34c

HAMMERSMITHS.—Wanted, a Tilter. Apply to the N. Y. Cast Steel Works, foot of 24th street, East River, New York. 6tf

FOWLERS & WELLS, Phrenologists and Publishers, Clinton Hall, 131 Nassau st., New York—Office of the Water Cure and Phrenological Journals. Professional examinations day and evening. 36m

ALLEN'S PLANING MACHINE.—Sole proprietor for Ohio, D. E. GARDNER, Marietta, Ohio. 34*

Patent Office.

128 FULTON ST. NOTICE TO INVENTORS.—Inventors and others requiring protection by United States Letters Patent, are informed that all business relating to the procurement of letters patent, or filing caveats, is transacted at the Scientific American Office, with the utmost economy and despatch. Drawings of all kinds executed on the most reasonable terms. Messrs. Munn & Co. can be consulted at all times in regard to Patent business, at their office, and such advice rendered as will enable inventors to adopt the safest means for securing their rights. Arrangements have been made with Messrs. Barlow and Payne, Patent Attorneys, in London, for procuring Letters Patent in Great Britain and France, with great facility and despatch. MUNN & CO., 128 Fultonstreet, New York.

AMERICAN AND FOREIGN PATENT AGENCY.

WE WOULD remind our numerous friends throughout the country, that we still continue to conduct the business of procuring Letters Patent for new inventions in this and all foreign countries, where the right is recognized. Since making arrangements with those eminent attorneys, Messrs. Barlow, Payne & Parken, Editors of the London Patent Journal, we have secured and managed through them, several foreign applications, with the utmost economy and facility. Inventors and others, desiring advice upon this subject, can correspond confidentially with the Editors of this paper.

WOODWORTH'S PATENT PLANING Machine 1850 to '58.—Decisions had the present year in the U. S. Courts, in every part of the Union, having fully and finally established all the claims of the Woodworth Patent, the subscriber is prepared to dispose of rights to use the machine in the Counties of Queens, Richmond, Rockland, Suffolk, Westchester, and the other unoccupied Counties and Towns in the State of New York and in Northern Pennsylvania. Ninety-nine hundredths of all the planed lumber used in our large cities and towns continue to be dressed with Woodworth's machines, which may be seen in constant operation in the steam planing mills in New York, Brooklyn, Williamsburgh, Albany, Troy, Utica, Rome, Syracuse, Rochester, Lockport, Buffalo, Elmira, Gibson, Oswego, Ithaca, Binghamton, &c. &c. Persons holding licenses from the subscriber are protected by him against infringements on their rights. JOHN GIBSON, 45* Planing Mills, Albany, N. Y.

PATENT METALIC OIL FOR MACHINERY.—Warranted not to gum. Manufactured under Cumberland Brothers patent (April 6th 1849), by C. B. de la Vergne & Co., Elizabethport, N. J. Transparent metallic, adapted to light bearings, spindles, &c., will last a quarter longer than pure sperm. For burning will be found superior. Fluid White Metallic, of the consistence of cream, to be used without wick and tube, adapted to the oiling of engines, shaftings, &c. will last twice as long as pure sperm oil. Hard White Metallic, to be used instead of tallow, will last three times as long; when used in cylinders, the packing must be renewed. Blue Metallic grease, prepared for greasing the inside of boilers when thoroughly cleaned, that the scale which afterwards collects may be removed with one third the usual time and expense. It is also adapted to the greasing of cog wheels; and for the axles of vehicles it has been found to last more than four times as long as any grease ever used for that purpose. KENNEDY & GELSTON, Sole Agents, 50 3m No. 8 Pine st. New York.

HISTORY OF PROPELLERS.—This interesting and useful volume, compiled by one of the Editors of the Scientific American, from articles previously prepared for, and published in, Vol. 5 of that paper, is now ready for the Trade. It contains 144 pages of letter-press, and 82 illustrations, embracing views of nearly every kind of propeller that has been invented. This work is beautifully bound in cloth, and is sold at the low price of 75 cts. We also have them in paper covers, for mailing—price as above. Address MUNN & CO., at this Office.

CLOCKS FOR CHURCHES, PUBLIC Buildings, Railroad Stations, &c.—The subscriber having made important improvements in the apparatus for counteracting the influence of the changes of temperature upon the pendulum, and in the retaining power, together with a most precise method of adjusting the pendulum to correct time, are prepared to furnish Clocks superior to any made in the United States, both for accuracy of time-keeping and durability. They speak with confidence, from having tested their performance for several years. All clocks ordered and not proving satisfactory, may be rejected. Address SHERRY & BYRAM, Oakland Works, Sag Harbor, L. I. "Mr. Byram has established his reputation as one of the first clock makers in the world"—[Scientific American. 4 3meow*

12 POWER PLANING MACHINES.—SCRANTON & PARSHLEY, New Haven, Conn., have now finishing up 12 power Planers that will plane 8 feet long, 27 inches wide and 24 inches high; these planers are of the first quality, are self-feeding every way; the table is worked by a rack and pinion; the bed is 12 feet long. With each planer there is a splining head and counter shaft, pulleys and hangers. They weigh about 4000 lbs.; the price, boxed and ready to ship, is \$325. Also 12 hand lathes, with back gear on iron shafts, and legs 7 feet long, swing 20 inches, about 700 lbs. weight—\$75. These lathes are of the first quality. 1tf

FELLOE CUTTING MACHINE.—Messrs. JOSEPH ADAMS & SON, Amherst, Mass., offer for sale town, county and State rights, or single machines, with the right to use, of this unrivalled Felloe Cutting Machine, illustrated in No. 5, Vol. 6, Scientific American. It is portable, easily kept in order, requires but little power to drive it, and will execute in the most rapid and perfect manner, cutting 60 good felloes in one hour. 6tf

RAILROAD CAR MANUFACTORY.—TRACY & FALES, Grove Works, Hartford, Conn. Passage, Freight and all other descriptions of Railroad Cars, as well as Locomotive Tenders, made to order promptly. The above is the largest Car Factory in the Union. In quality of material and in workmanship, beauty and good taste, as well as strength and durability, we are determined our work shall be unsurpassed. JOHN R. TRACY, THOMAS J. FALES. 5tf

LAP-WELDED WROUGHT IRON TUBES for Tubular Boilers, from 1 1/4 to 7 inches in diameter. The only Tubes of the same quality and manufacture as those so extensively used in England, Scotland, France and Germany, for Locomotive, Marine, and other Steam Engine Boilers. THOS. PROSSER & SON, Patentees, October 29, 1850. 28 Platt st., New York.

ALCOTT'S CONCENTRIC LATHES.—We have on hand a few of these celebrated Lathes, which the inventor informs us will execute superior work at the following rates:— Windsor Chair Legs and Pillars, 1000 per 11 hours. Rods and Rounds, 2000; Hoe Handles, 800; Fork Handles, 500; Broom Handles, 150, per 11 hours. This Lathe is capable of turning under two inches diameter, with only the trouble of changing the dies and pattern to the size required. It will turn smooth over swells or depressions of 3/4 to the inch, and work as smoothly as on a straight line, and does excellent work. Sold without frames for the low price of \$25—boxed and shipped, with directions for setting up. Address, (post paid). MUNN & CO., 14tf At this Office

CARD.—The undersigned begs leave to draw the attention of architects, engineers, machinists, opticians, watchmakers, jewellers, and manufacturers of all kinds of instruments, to his new and extensive assortment of fine English (Stubs) and Swiss Files and Tools, also his imported and own manufactured Mathematical Drawing Instruments of Swiss and English style, which he offers at very reasonable prices. Orders for any kind of instruments will be promptly executed by F. A. SEBENMANN, Importer of Watchmakers' and Jewellers' Files and Tools, and manufacturer of Mathematical Instruments, 154 Fulton street. 1 3m*

TO PAINTERS AND OTHERS.—American Anatomic Drier, Electro Chemical graining colors, Electro Negative gold size, and Chemical Oil Stove Polish. The Drier, improves in quality, by age—is adapted to all kinds of paints, and also to Printers' inks and colors. The above articles are compounded upon known chemical laws, and are submitted to the public without further comment. Manufactured and sold wholesale and retail at 114 John st., New York, and Flushing, L. I., N. Y., by QUARTERMAN & SON, Painters and Chemists 48tf

COTTON, WOOLEN AND SILK MANUFACTURERS' DEPOT.—ANDREWS & JESSUP, No. 70 Pine st., N. Y., dealers in articles for the use of Cotton, Woolen and silk manufacturers, and agents for the sale of shearing, carding, burring, napping, wool-picking, flock-cutting and waste machines, regulators, satinet and jean warps, &c. Weavers' reeds and heddles, bobbins and spools, of every description, made to order. Sperm, lard and olive oils and oil soap. 1tf

WOOD'S PATENT SHINGLE MACHINES.—These excellent machines, illustrated and described in No. 23, Vol. 5, Scientific American, are offered for sale in Town, County and State Rights, or by single machines. There are three sizes, the first cuts an 18 inch shingle, price, \$100; 2nd cuts 24 inch, price \$110; 3rd, 28 inch, \$120. Orders addressed to J. D. Johnson, Redding Ridge, Conn., or to Munn & Co., "S Am." Office, will meet prompt attention. The above machine can be seen in successful operation at P. R. Roach's mills, No. 135 Bank st., this city. 51tf

MACHINERY.—S. C. HILLS, No. 12 Platt Street, N. Y., dealer in Steam Engines, Boilers, Iron Planers, Lathes, Universal Chucks, Drills, Kase's, Von Schmidt's, and other Pumps, Johnson's Shingle machines, Woodworth's, Daniel's and Law's Planing machines, Dick's Presses, Punches, and Shears; Mortising and Tenoning Machines, Belting, machinery oil; Beal's patent Cob and Corn Mills; Burr Mill, and Grindstones, Lead and Iron Pipe, &c. Letters to be noticed must be post paid. 46tf

MATTEAWAN MACHINE WORKS.—Locomotive Engines, of every size and pattern. Also tenders, wheels, axles, and other railroad machinery. Stationary engines, boilers, &c. Arranged for driving cotton, woolen and other mill. Cotton and woolen machinery of every description, embodying all the modern improvements. Mill gearing, from probably the most extensive assortment of patterns in this line, in any section of the country. Tools, turning lathes, slabbing, planing, cutting, and drilling machines. Together with all other tools required in machine shops. Apply at the Matteawan Co. Work, Fishkill Landing, N. Y., or at No. 66 Beaver st. New York City, to WILLIAM B. LEONARD, Agent. 40tf

WOODWORTH'S PLANING MACHINE.—For sale, the right to use this justly celebrated labor-saving machine in the following States, viz. Pennsylvania west of the Allegheny Mountains, Virginia west of the Blue Ridge, Ohio, Indiana, Kentucky, Tennessee, Wisconsin, Iowa, Missouri, Arkansas, Texas, Louisiana, Florida, Alabama and Mississippi. For particulars apply to the Proprietor, ELISHA BLOOMER, 304 Broadway. 51tf

BRUSH'S IMPROVED DOUBLE-ACTING LIFT AND FORCE PUMP.—From the increased facilities of the subscriber, he is now prepared to furnish, at a reduced price, the most effective, powerful, durable and yet simple Lift and Force Pump in use. For a house pump, factories, breweries, railroad stations, or any other purpose where a constant stream of water is required, they cannot be surpassed. The public are cautioned against an article purporting to be Brush's Pump, but are invited to call at or address 83 Pike Slip, and get the original. J. A. BRUSH, Inventor. 49 3m*

FACTORY AND WATER POWER.—For rent or sale.—A factory building in New Brighton, Beaver Co., suitable for woollen or cotton factory, 40 by 90 feet, three stories high, with plenty of water power. The driving power is now being made new, and if applied for soon, can be made to suit the renter. Apply to A. W. TOWNSEND, near the premises, or to J. W. GILL, Wheeling, Va. 3 8*

FOREIGN PATENTS.—PATENTS procured in GREAT BRITAIN and her colonies, also France, Belgium, Holland, &c., &c., with certainty and dispatch through special and responsible agents appointed, by, and connected only with this establishment.—Pamphlets containing a synopsis of Foreign Patent laws, and information can be had gratis on application JOSEPH P. PIRSSON, Civil Engineer, Office 5 Wall street, New York. 46tf

BOSTON LOCOMOTIVE WORKS.—No. 380 Harrison avenue, Boston, manufacture at short notice, Locomotive and Stationary Steam Engines, boilers,—iron, copper, composition and brass castings; copper work; Van Kuran railroad car and truck wheels, and all kind of railroad machinery. DANIEL F. CHILD, Treasurer Boston Locomotive Works. 1tf

TO IRON FOUNDERS, &c.—Fine ground and bolted Foundry Facing, viz.: Sea Coal, Charcoal, Lehigh, Soapstone, and Black Lead. Fire Clay, Fire Sand, Keold and Fire Mortars; also Iron and Brass Founder's superior Moulding Sand, in barrels, or otherwise, for sale by G. O. ROBERTSON, New York City Office 4 Liberty Place, Maiden Lane, near the Post Office. 8 4*

Scientific Museum.

Scientific Memoranda.

IODINE.—M. Chatin finds that iodine may be detected in the three kingdoms of nature:—water, plants, and animals, all affording by analysis very decided indications of its presence. He has detected it also in several lead ores and in graphite. It appears, says M. Chatin, that, in the ancient world as in the new, the presence of iodine is evident,—and the proportions in which it is found in the vegetable debris hidden in the soil, afford the geologist means for ascertaining the distribution of water in ancient days. Thus a coal which is rich in iodine ought to prove that the vegetation had been developed in a marshy land,—and those coals which do not contain iodine, that it was formed from plants of a more decidedly terrestrial character.

CAUSES OF GOITRE AND CRETENISM.—Doctor Grange, a learned Physician of Paris, was commissioned some time ago by the government, to pursue, in France and other countries, inquiries into the causes of *goitre* and *cretenism*. His official report has just appeared, and will be deemed by the medical faculty a valuable document. After Bibliographical researches embracing Europe, America and the East Indies, respecting the existence of those affections, and from his own extensive observation, he has come absolutely to the conclusion that they are independent of latitude, altitude and climate and even of circumstances of habitation, poverty, and so forth. Their presence appears to be connected with that of magnesia in food or drink; their absence often proceeds from the *iodine* which the article consumed offers to chemical analysis. Dr. Grange estimates that there are in France four hundred and fifty thousand persons afflicted with *goitre*, and from thirty-five to forty thousand with *cretenism*. Females are more subject to the disease than the other sex. In Savoy there are at least a hundred thousand sufferers. In some localities the substitution of spring for well-water has sufficed to banish *goitre*. The Doctor recommends marine salt—ioduret of potassium cisterns of proper water, and so forth; and he thinks that much can be done by government towards the cure and future security of the populations among whom the distemperature is found.

REMARKABLE PRESERVATION.—An officer of our Navy on his voyage to China, writing lately to his friend in Washington City, relates the following singular occurrence:

"A singular and (to the party concerned, at least) highly interesting circumstance occurred about the time we were off the Cape of Good Hope. From the time that we reached the cooler latitudes of that region we were constantly surrounded by birds, and sometimes in great numbers, whose exquisitely graceful movements on the wing was a constant source of admiration to us all. One morning, when even a greater number than usual, including several large albatrosses, were following the ship, the startling cry was heard of "man overboard," and it proved to be an unlucky Irishman, who had got to the forepart of the vessel to throw a dirt swab overboard, and Paddy-like, had dropped himself into the water instead of the swab. We were soon hoisted, and a boat lowered to go in search of the man, for whom they looked in vain, until they rowed, as a last hope, to a spot round which all the birds were suddenly observed to cluster, where they found the poor fellow in a state of insensibility and exhaustion. Around him the birds were hovering with discordant screams, and, strange to relate, two great albatrosses had seized him by his clothes, thus keeping him from sinking, whilst several were picking at his head and face! When the boat reached him he was unconscious, and had ceased all exertions, so that he doubtless owed his life to these birds. The patent life buoys, as is usually the case, did not reach the water, although the port-fires burned and smoked away furiously.

WASTE LAND.—There is enough in this country. But we generally suppose that in

Great Britain almost every acre is cultivated or in some way turned to profit. Prof. McLain informs us that of 11½ millions of acres in Scotland, susceptible of tillage, 5½ millions only are cultivated. And the reason for this ought to be a lesson to us against selling our public domain to non-users. He says that this 6 millions of acres, if divided into small farms and given to actual workers, would well sustain a farming population equal to the whole number that now subsists on the cultivated land. In England the waste land, though less, is very great. The number of acres cultivated but unproductive, is probably lower and would exceed belief; to say nothing of commons, wastes, lanes not required, fence spaces, field corners, &c., that economy might turn to account.

The best thing the land owners in Britain can do, is to erect a greater number of small farms than she now has.

Clark's Patent Auger.

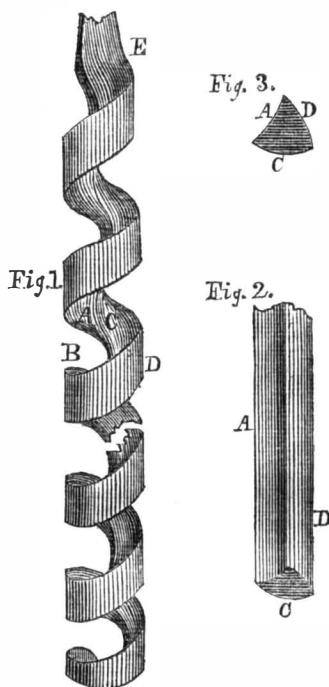

This improvement is the invention of Mr. William N. Clark, of Chester, Middlesex Co., Conn., and was secured to him by patent in January, 1845. We are thus particular about the date, as it has been stated to us that there are a great number infringing his rights, which is very wrong, for he is a sincere and ingenious mechanic. The improvement is on the auger known as the "single twist."

Figure 1 is a view of the auger broken off, but showing its form; figure 2 is the form of the material before it is twisted, and figure 3 is a section of the material.

The inner surfaces of the twist of the common auger are convex; this form is objectionable, as it breaks the chip and causes the fragments to work in between the outside of the auger, and rendering it necessary to withdraw it frequently in the process of boring, to clear it of the chips. The auger is also liable to be injured by such frequent removal, the pressure being such as to act upon the twist so as to derange it. The improvement consists in making the upper inner surface, A, of the twist of the auger, B, concave, so that the auger of any desirable length works easily and freely, raising the chips continuously through the cavity to the top of the hole without breaking the chip or leaving any fragments to work between the outside of the auger and inner surface of the hole, and thereby overcoming entirely the evil of clogging and the frequent withdrawal of the auger during the process of boring. The hole made by it is smooth and accurate, and the time and labor of the operator is much abridged. This principle of construction may be applied to the *bit* and *gimblet*, A being the inner concave surface, C the convex surface, and D the outer surface. The claim of this patent is the mode of making a single twist ship auger, the bit and gimblet, with the upper inner surface, A, of the twist, concave, as above described, for the object set forth.

We publish the following certificate to show how this improvement is estimated by one well qualified to judge of its merits. Com-

munications about rights, &c., may be addressed to the patentee at the above mentioned place.

U. S. NAVY YARD, Brooklyn, Jan. 27, 1848. Having proved the Ship Auger patented by Mr. Wm. N. Clark, by testing its capacity for boring, I can safely assert that it is the best article of the kind I have ever used, and therefore recommend it to all ship builders as a superior article.

JOHN M. WEEKS,
Foreman of Navy Yard.

For the Scientific American.

Some Peculiar Properties of Water and Air.

Water seems to retain only a certain bulk of air; a slight elevation of heat in cold water occasions an expansion of its air, and produces a surplus of bulk, which is set free: a relief of pressure will have the same effect. Water that has been heated to the boiling point, on cooling again, does not readily absorb its former bulk of air, and consequently it is a quicker conductor of heat, will freeze sooner than that which has not been heated, and, it would seem, must be better for tempering steel.

The atmosphere will also take up water in proportion to its warmth; hence the variability of temperature produces rain and dew. Warm earth thrown up to the cold air will produce an opaque vapor; the reason is, the cold air is warmed on the wet earth, and this absorbs a portion of moisture, which rises, becomes cool, on mingling with the cold air, and is given out again visible like fog; and it is by the same rule that drops of water collect on a tumbler of cold water in a warm summer's day.

But this rule appears to be reversed, or at least varied, when above the boiling point. Take a kettle of cold water, fill a vial with the same, and invert it under the water, heat moderately up to the boiling point, and you may observe the operation of water and air by a change of temperature; as the water begins to warm, its surplus bulk of air begins to escape and occupy the upper part of the vial, and before the water boils, the air and vapor will have forced all the water out of the vial by their lively expansion. Immediately above this degree of heat the affinity of water or steam and air appears to be reversed, as may be argued from the result of my experiment with steam from a boiler; and I think we may account for the dripping of stove pipes in cold weather, when nothing is used for fuel but dry coal, upon this principle; the draft of air, though cold, contains a portion of vapor which is heated, so that separation from the atmospheric air and carbonic acid gas takes place, and as it flies along to where the pipe is cool, it condenses on the upper portion of the pipe and runs down. That steam and air may separate by heat, is nothing more than reasonable; for a separation is produced by heat between many other combinations in the same way and for the same reason; that is, one ingredient is rarified and made lighter than the other; and the reason for the change of property between air and its vapor by an elevation of heat, is undoubtedly on the same principle by which their affinity is overcome. By reference to the gravity of the respective gases of water and air, it will be seen that water brought into the gaseous state, so as to possess the same independent elasticity of atmospheric air, must necessarily become lighter, and possibly as much lighter as the difference between the amount of weight of the gases that belong to each separate composition.

For some reason air has a tendency to impart elastic properties to water; and it is evident that the air of water will generate steam even under a great pressure, sooner than heat alone; and from this fact it is evident that the reason why water does not all take the elastic state at once, like gunpowder, is simply because the air of the water is a slow conductor of heat, and must be heated to a certain point before the elastic properties are imparted to the water.

A. C.

It is estimated that the gold and silver imported into the United States, from various parts of the world, over and above the exports, during the last three years, amounts to one hundred millions of dollars.

The average price for gas, charged by all the gas companies of Britain is \$1.50 per 1,000 cubic feet.

LITERARY NOTICES.

DICTIONARY OF MECHANICS AND ENGINE WORK.—Number 20 of this work, published by D. Appleton & Co., Edited by Oliver Byrne, is a very excellent number; it contains an illustrated description of Vogel's ingenious Harness Machine, taken from No. 6, Vol. 4, Sci. Am. It is not so well done as in our columns—two important engravings having been left out by the editor: this reminds us that excellent harnesses by this machine are made at Matteawan. It also contains engravings and a description of the Prussian Rifle, or "Zund Nadel," taken from page 124, Vol. 5, Sci. Am. The editor says that Jennings's Patent Rifle is the simplest of breech-loading fire-arms, but this rifle is far more complex than Sharp's, which was published in No. 25, Vol. 5, Sci. Am. It also contains an illustrated description of Barber's Metallic Grist Mill, published in No. 7, Vol. 4, Sci. Am. As the public may not be aware that any of our editorial lucubrations are contained in this work, we merely refer to those things so that the — may have his due.

NEWTON'S PRINCIPIA.—Mr. Daniel Adee, No. 10 Fulton street, this city, has issued another beautiful edition of Newton's great work, "The Principia." For a long time the "Principia" was kept far out of the reach of the mere English Scholar, as if Newton had written it exclusively for the classical student and philosopher. It was a scarce book when first printed in the Latin language; it is now, thanks to the spirit of an American publisher, printed in our mother tongue, and should find a place in every family library.

THE PRE-ADAMITE EARTH.—Who has not heard of this great work, by Harris, the author of the Great Teacher? Its fame is world-wide, but until now its availment to many particular American readers of useful books, has been out of the question. To Messrs. Gould, Kendall & Lincoln, of Boston, the well-known publishers, the public are indebted for a new, beautiful and cheap edition of the work. Its title conveys an idea of its nature; its object is to teach "that there is a theology in nature which is ultimately one with the theology of the Bible." Its field is geology, and embracing views respecting which there has been much of what is termed infidel and christian controversy and conflicting opinions, it is at the present moment something with which professors of religion, at least, should not be ignorant.

HOLDEN'S DOLLAR MAGAZINE, for November, contains a portrait of Louis Philippe and a review of its character. It is a good number. Publishing Office No. 109 Nassau street, N. Y., by Fowler & Dietz, and Hotchkiss & Co., 13 Court street, Boston.

MECHANICS

INVENTORS
AND
MANUFACTURERS.

The Best Mechanical Paper
IN THE WORLD!

SIXTH VOLUME OF THE
SCIENTIFIC AMERICAN.

The Publishers of the SCIENTIFIC AMERICAN respectfully give notice that the SIXTH VOLUME of this valuable journal, commenced on the 21st of September last. The character of the SCIENTIFIC AMERICAN is too well known throughout the country to require a detailed account of the various subjects discussed through its columns.

It enjoys a more extensive and influential circulation than any other journal of its class in America.

It is published weekly, as heretofore, in *Quarterly Form*, on fine paper, affording, at the end of the year, an *ILLUSTRATED ENCYCLOPEDIA*, of over FOUR HUNDRED PAGES, with an Index, and from FIVE to SIX HUNDRED ORIGINAL ENGRAVINGS, described by letters of reference; besides a vast amount of practical information concerning the progress of SCIENTIFIC and MECHANICAL IMPROVEMENTS, CHEMISTRY, CIVIL ENGINEERING, MANUFACTURING in its various branches, ARCHITECTURE, MASONRY, BOTANY,—in short, it embraces the entire range of the Arts and Sciences.

It also possesses an original feature not found in any other weekly journal in the country, viz., an *Official List of PATENT CLAIMS*, prepared expressly for its columns at the Patent Office,—thus constituting it the "AMERICAN REPERTORY OF INVENTIONS."

TERMS—\$2 a-year; \$1 for six months.
All Letters must be Post Paid and directed to
MUNN & CO.,
Publishers of the Scientific American,
128 Fulton street, New York.

INDUCEMENTS FOR CLUBBING.

Any person who will send us four subscribers for six months, at our regular rates, shall be entitled to one copy for the same length of time; or we will furnish—

10 copies for 6 mos., \$3 15 copies for 12 mos., \$22 10
10 " 12 " \$15 20 " 12 " \$28

Southern and Western Money taken at par for subscriptions; or Post Office Stamp taken at their full value.

PREMIUM.

Any person sending us three subscribers will be entitled to a copy of the "History of Propellers and Steam Navigation," re-published in book form—having first appeared in a series of articles published in the fifth Volume of the Scientific American. It is one of the most complete works upon the subject ever issued, and contains about ninety engravings—price 75 cents.