

Class

Book



PRESENTED BY

----- THE PUBLISHERS -----

form 38 [10-15-08-5m]

The Locomotive

PUBLISHED BY THE HARTFORD STEAM BOILER INSPECTION AND INSURANCE COMPANY.

VOL. XXVI.

HARTFORD, CONN., JANUARY, 1906.

No. 1.

Concerning Steel Pipe.

Nearly all of the pipe that is now used for steam, water, and gas, is made of steel; iron pipe being supplied only when the specifications explicitly call for it. There is, however, a certain prejudice against steel pipe in the minds of many engineers, partly because of a belief that steel pipe corrodes more freely and rapidly than iron pipe, and partly because experience indicates that it is harder to get a good thread on a steel pipe than upon an iron one. Mr. Frank N. Speller, of the National Tube Company, has prepared a paper touching upon these points, which is published in the eighth volume (1905) of the *Journal* of the Canadian Mining Institute; and, with the permission of Mr. Speller, we reprint extracts from the

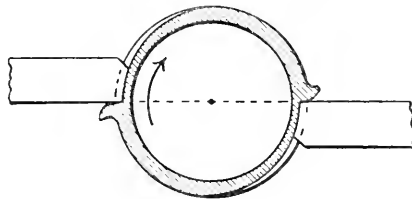
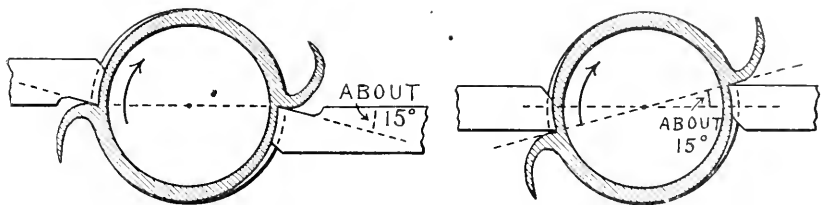

FIG. 1. — OLD FORM OF CHASER, FOR IRON PIPE.



FIGS. 2 AND 3. — NEW FORM OF CHASER, FOR STEEL PIPE.

paper below, as we conceive them to be of deep interest to all steam engineers. We regret that we cannot reproduce the paper in full.

In certain districts much has been heard from plumbers and steam-fitters on the difficulty of threading steel pipe, particularly in the field, where hand tools must be used.

When soft Bessemer steel was first made by the National Tube Company for the manufacture of welded pipe, the question of tools was thoroughly investigated by the threading departments. Fig. 1 shows the old form of chaser, which was used on iron pipe. This form will cut a fair thread on iron, because iron is weaker than steel, and is so broken up in structure by interspersed cinder as to be

more or less rapidly worked with such a tool. Bessemer steel of the quality proven to be best adapted for pipe, being much tougher and stronger than wrought iron, cannot be pushed out between the threads in the same manner. A clean and easily-cut thread can be made, however, by putting an angle of shear upon the chaser, as illustrated in Figs. 2 or 3. Care as to clearance and lubrication will also greatly facilitate the work; good lard or cotton seed oil being used in liberal quantities.

In machine threading at the National Tube Works, a proper form of chaser has proven to be the first consideration in economical thread-cutting. Tools constructed as here shown will cut steel or iron with equal ease; but mill records show better results with the tools used on steel, owing to the increased wear and tear caused by the two or three per cent. of cinder included in wrought iron. A recent investigation of hand-threading tools clearly showed that few are made on this principle; and hence the trouble complained of by those using hand tools on steel pipe was not hard to explain. After some experimenting, in co-operation with several steam-fitters who had experienced this difficulty, it was found that after the adoption of the proposed angle of shear there was no perceptible difference in threading either iron or steel, and stronger and cleaner-cut threads were invariably obtained on the steel pipe.

Many cases of split joints, which necessitated the costly removal of pipe lines, have been traced to excessive torsional strains produced by the use of poor threading tools. The damage is usually charged to poor welds; but as every piece must pass the tester* before leaving the works, this is not the cause of the difficulty. Moreover, experience shows that the trouble ceases on altering the die, or buying one of proper shape.

Mild steel has had to live down prejudice in nearly every line where it has displaced wrought iron. The most suitable quality of Bessemer steel for pipe manufacture has been determined by much expensive experimenting, and the quality adopted has proven much more satisfactory in welding. The process of manufacture of soft steel pipe, being a continuous one from ore, through blast furnaces, Bessemer converters, blooming mill, rolling mills and tube works, under one management, with critical inspection at each point, insures the highest practical degree of uniformity in the product. Steel scrap from the pipe and rolling mills, not used up by the Bessemer department, finds a ready market at neighboring open-hearth plants. It is not an uncommon practice for some concern making "strictly wrought iron pipe" to use a considerable portion of miscellaneous steel scrap of varying composition. This often results in hard spots and weak welds, which when discovered, are frequently credited to intermixed steel pipe. The prejudice created is so strong in some minds that any defective pieces are at once put down to the accidental shipment of some steel pipe with the order. A few such cases were investigated recently by the writer, who found that some fifty pieces of defective pipe (mostly defective by open welds) were all "wrought iron," much to the surprise of the consumers. The National Tube Company, who furnished facilities for this present paper, and made many of the tests referred to, are not only the pioneers in the introduction of soft Bessemer steel pipe, but they also manufacture wrought iron, in certain grades of which scrap of the same class is used to make up the center of the pipe.

Naturally the makers of wrought iron pipe to whom a supply of suitable steel is not available, make the most of the suspicion which the word "steel" still raises

* Pipe made at the National Tube Works is all tested at from 600 to 2,000 pounds per square inch, according to the purpose for which it is made.

in the minds of some people who are not informed concerning the modern advances in this industry. It seems quite reasonable to suppose that the advantages of superior strength, ductility, homogeneity, finish, and lower cost, which accompany the use of steel pipe, would be more generally recognized if such misapprehensions as these regarding threading and corrosion were cleared up.

Soon after soft steel began to supersede wrought iron in general engineering construction on account of its superior strength, ductility, toughness, and uniformity in composition, the question of relative durability was brought up. This led to many elaborate experiments, under conditions approximating those which promote corrosion in practice, which have been continued and discussed by many of the best investigators for the past twenty-five years.* The most trustworthy of these results up to 1892 have been concisely reviewed and compared by Prof. H. M. Howe,† with the conclusion that, so far as the relative corrosion is concerned, no important difference exists between iron and steel, although the variable effect of different conditions is more marked [in the case of steel]. Later, in 1895, the same investigator expresses his conclusions in a paper entitled "Relative Corrosion of Wrought Iron and Steel," in the following terms: "It is misleading to say that normal low carbon steel corrodes more, or that it corrodes less, than wrought iron; since the relative corrosion varies with the enclosing medium. I think that we have very strong reason to believe that such steel, when carefully made, resists corrosion in fresh water as well as wrought iron; in cold sea water, at least nearly as well as wrought iron; and in acidulated water, better than wrought iron."

The most dangerous form of corrosion in pipes is pitting. Some tests made by the United States Navy Department‡ during the past three years give interesting data on the point, and suggested other investigations along this line to the writer, results of which will be given later. The Navy Department tests were made in aerated distilled water at the normal temperature of the room, on 48 pieces of each of the following materials: Charcoal iron, Bessemer steel, and hot and cold-drawn seamless tubes made from the same lot of open-hearth steel.

The samples were of steel from all parts of the ingot, and were insulated in twelve porcelain-lined tanks, a plentiful amount of pure air being supplied through perforated glass tubes. The tests were continued for 64 weeks, and at the end of each period of 16 weeks the samples were removed, cleaned and weighed. While under test, every precaution was taken to subject each piece to the same corrosive influences as the others; the essential agents of corrosion (namely, oxygen, carbonic acid and moisture) being given full play. The average loss of weight, per square inch of surface for the whole period of 64 weeks, was as follows, the loss experienced by charcoal iron being taken as 100.0. For hot-drawn, seamless open-hearth steel, the loss was 93.7; for lap-welded Bessemer steel it was 94.5; and for cold-drawn seamless open-hearth steel it was 101.3.

Mill scale, being electro-negative to iron (by about 0.4 volt), is evidently largely responsible for the deep corrosion on bare metal adjacent to firmly attached scale.§ Further, it has been found that duplicate plates of iron and steel, exposed with and without mill scale on their surfaces, sustain nearly the same loss

* T. Andrews, *Proceedings of the Institute of Civil Engineers*, (English,) Vol. 77, page 323, and Vol. 82, page 281.—Discussion by Sir H. Bessemer and Sir William Siemens, *Proceedings of the Institute of Civil Engineers*, Vol. 65, page 101.—W. Parker (Lloyd's Register), *Journal of the Iron and Steel Institute*, 1881, Vol. 1, page 39.

† *Metallurgy of Steel*, page 94.

‡ *Journal of the American Society of Naval Engineers*, May, 1904.

§ *Journal of the Iron and Steel Institute*, 1879, Sir N. Barnaby, page 53; 1887, Vol. 1, page 461.

in weight; the clean surfaces being uniformly corroded, while the scale-bearing surfaces are more or less pitted. This explanation of the cause of pitting, which seems to satisfactorily account for the facts observed, applies equally to all classes of iron and steel.

The effect of contact of dissimilar irons and steels with each other and with plates of the same material carrying the natural mill scale, was the subject of experiments made at the laboratory of the National Tube Company, McKeesport, Pa., last year. In this case, also, Bessemer steel and open-hearth steel compared advantageously with common iron and charcoal iron.

Observations of corrosion of pipe in practice, if the results are to be worth anything, must be made on material in use under the same influences, to ensure which, both materials should be in use at the same time. In making observations in the field, it is often difficult to determine just what conditions prevail, and whether or not both materials were subjected to the same environment; for the conditions which most influence the rate of corrosion (besides oxygen and carbonic acid with moisture, which may be considered as primary causes), are intricately involved. They include principally:

1. Galvanic action, (a) by metallic contact,* (b) by the heating of one portion of the metal (thermoelectric action), (c) by the difference of potential between strained and unstrained portions, which has lately been shown to be an important factor. The strained part of a piece, being electropositive to the unstrained portion, corrodes quicker.†

2. Electrolysis‡ is a widespread and increasing accelerator of corrosion, which all precautions cannot entirely avoid. A difference of potential of the thousandth part of a volt is sufficient to increase corrosion considerably, and this may exist one or two miles from a dynamo.

3. Increased amounts of corrosive matter in air and water, especially near the large centers of population, where the greater portion of pipe is in use, together with the complicated and far-reaching action of stray currents, have materially increased the danger of corrosion during the past ten or fifteen years, since steel pipe began to be generally adopted. A fair comparison with pipe in use at a previous date is therefore clearly impossible; and yet many decri present-day pipe material, and deplore its degeneration. Fortunately, much energy is being better spent in providing efficient protection for iron and steel exposed to such corrosive conditions.

After all, the best evidence of the practical insignificance of the difference between the rates of corrosion of these materials probably lies in the fact that after twenty-five years of investigation and discussion the question is not absolutely settled, there being still just enough difference one way or the other to indicate that under some conditions each material has a small advantage over the other, while in the majority of cases the differences are hardly perceptible.

VOLUME 25 of THE LOCOMOTIVE, containing the eight numbers issued during the years 1904 and 1905, may now be had upon application to the Hartford office of this company. The price is one dollar per volume, the same as heretofore.

* *Transactions of the Royal Society*, Vol. 32, page 218.

† *Bulletin of University of Wisconsin*, No. 2, Engineering Series, Vol. 2, No. 8, July, 1900.

‡ *Rustless Coatings* (Wood), page 370. (John Wiley & Sons, 1904.)

Boiler Explosions.

AUGUST, 1905.

(234.) — A tube burst, on August 1, in a water-tube boiler at the plant of the Denver City Tramway Co., Denver, Col. Nobody was hurt.

(235.) — A boiler exploded, on August 1, in a steam laundry at El Reno, Okla. Nobody was injured.

(236.) — On August 3 the cast-iron mud-drum of a water-tube boiler exploded in a woolen mill owned by the Springville Manufacturing Co., at Rockville, Conn. Night Watchman Harry Morrell was injured so badly that he died a few hours later. The property loss was about \$2,000.

(237.) — A blow-off pipe ruptured, on August 3, in the furniture factory of the California Lumber & Milling Co., at West Berkeley, Cal. Nobody was hurt.

(238.) — A boiler exploded, on August 4, in McCortland & Co's oil refining plant, at Petrolea, Canada. Patrick Kelley was injured seriously, and William Hammond received lesser injuries.

(239.) — On August 4 a boiler exploded in George Churchill's sawmill, near DePauw, twenty-five miles west of Louisville, Ky. The proprietor's son and nephew were badly scalded, and the mill itself was badly damaged.

(240.) — On August 5 a tube ruptured in a water-tube boiler in the plant of the Carbonic Dioxide Corporation, Canal and Lumber streets, Chicago, Ill.

(241.) — A tube exploded in a water-tube boiler, on August 6, in the Omega Portland Cement Co's plant, at Jonesville, Mich.

(242.) — On August 7 the mud-drum of a water-tube boiler exploded in the plant of the Jarecki Manufacturing Co., at Erie, Pa. Jacob Lindgren, the night watchman, was scalded so badly that he died on the following day.

(243.) — A boiler exploded, on August 7, in T. J. Salts & Co's sawmill, near Del Rio, Cocks county, Tenn. Herman Tilsen, Frank Plate, and Joseph Turner were instantly killed and Merritt Burgin was fatally injured. Seven other persons were also injured less severely.

(244.) — A cast-iron section of a safety boiler ruptured, on August 8, in an office building belonging to the Forrest Estate, at 119 South Fourth street, Philadelphia, Pa. Nobody was hurt.

(245.) — On August 9 a tube ruptured in a water-tube boiler in the No. 2 station of the New Orleans & Carrollton Railway, Light & Power Co., New Orleans, La.

(246.) — The boiler of freight locomotive No. 2245, of the Pennsylvania railroad, exploded, on August 10, at Altoona, Pa. Engineer Nicholas H. Murphy and fireman John A. Lucas were injured so badly that they died in a short time. Conductor Halihan, in charge of another freight train which ran into the wreckage, was also injured less severely. The locomotive was demolished.

(247.) — A slight explosion occurred, on August 11, in a water-tube boiler at the Delray, Mich., plant of the Solvay Process Co.

(248.) — The boiler of freight locomotive No. 338, of the C., H. & D. railroad, exploded, on August 11, at Barnard, Ind. Fireman Manley J. Lamb was killed, and engineer C. W. Barnes was seriously injured. Brakeman Knowles suffered a broken wrist, and was also injured about the body.

(249.) — On August 16 a tube burst in a water-tube boiler at the Olympia Cotton Mills, Columbia, S. C. (See also the following explosion.)

(250.) — A tube ruptured, on August 17, in a water-tube boiler at the Olympia Cotton Mills, Columbia, S. C. (See also the preceding explosion.)

(251.) — The boiler of a threshing outfit exploded, on August 17, on a farm near Pana, Ill. John Misseur was injured, and the machinery was wrecked.

(252.) — A boiler used in connection with John Welch's threshing outfit exploded, on August 19, near La Crescent, Minn. Edward Selks and Benjamin Lipps were injured.

(253.) — A slight rupture occurred, on August 21, in the rolling mill of the Pine Iron Works Co., at Manatawny, Pa.

(254.) — A blow-off pipe ruptured, on August 22, in the plant of Euston & Co., Chicago, Ill. Fireman Frederick M. Hofsaes was killed.

(255.) — A boiler exploded, on August 22, in W. L. Stevens' sawmill, near Baton Rouge, La. Fireman Frank Smith was seriously but not fatally injured.

(256.) — The boiler of William Delano's threshing outfit exploded, on August 22, at Crump, Mich. One of the owner's sons was slightly injured.

(257.) — James Lynch, Isaac Wade, and two other men whose names we have not learned, were killed, on August 23, by the explosion of a boiler on a bridge boat near Norborne, Mo.

(258.) — On August 24 an explosion occurred in the engine room, or fire room, of the steamer *Lakona*, of the Donaldson line, as she was leaving Montreal for Glasgow. A. Jackson and Alexander Smith were killed, and Andrew Miller was badly scalded.

(259.) — Several cast-iron headers ruptured, on August 26, in a water-tube boiler at the plant of the American Beet Sugar Co., Chino, Cal.

(260.) — A vertical boiler exploded, on August 27, in the saw works of E. C. Atkins & Co., Indianapolis, Ind. John Long and Henry Hoffman were injured, and the property loss was about \$3,500.

(261.) — A slight explosion occurred, on August 29, in the wooden box factory of G. W. Middleton, at Philadelphia, Pa. Nobody was injured.

(262.) — A boiler exploded, on August 29, in Charles Caudill's distillery, at Flat Rock, near Franklin, Ky. Two men were scalded.

(263.) — A boiler exploded, on August 30, in a sawmill at Dorchester, Va. David Frazier and a boy whose name we do not know were badly scalded.

(264.) — The boiler of a locomotive exploded, on August 30, between Ellerson and Tucker, Ark. Nobody was injured.

(265.) — During the course of a fire at Haileybury, Ont., on August 31, a boiler exploded in the Little Brother sawmill. C. Desermeau and F. Pounder

were instantly killed by the flying wreckage, and M. Floody, George Dufour, and a man named Coates, were more or less seriously injured.

SEPTEMBER, 1905.

(266.) — On September 1 a tube ruptured in a water-tube boiler at the plant of the Carbonic Dioxide Corporation, Chicago, Ill., scalding C. Smith.

(267.) — A tube ruptured, on September 2, in a water-tube boiler at the Barker Cotton Mills, Mobile, Ala.

(268.) — A boiler exploded, on September 2, on the Ohio Oil Co's lease on the Martin Suhan farm, in Blue Creek township, near Decatur, Ind. Nobody was injured.

(269.) — On September 3 a boiler exploded in M. Eagle's sawmill, at Henning, Lauderdale county, near Covington, Tenn. The fireman was fatally scalded, and one other man was scalded severely, but not fatally. The mill was wrecked.

(270.) — A boiler used for roasting peanuts exploded, on September 4, at Evansville, Ind. Frederick Dillman was instantly killed, and Vincent Ameroso was fatally injured.

(271.) — The boiler of a Boston & Maine locomotive exploded, on September 5, near Springville, Me., on the Worcester, Nashua & Portland division of the Boston & Maine railroad. Engineer Charles Higgins and fireman John Holbrook were seriously scalded.

(272.) — A boiler exploded, on September 6, in the Shelby County Lumber Co's mills, at Neuville, near Center, Tex. George Lovell was killed, and another man, whose name we have not learned, was fatally injured. One man was also injured seriously, but not fatally.

(273.) — A boiler exploded, on September 7, in the Rogers Cutlery Co's plant, at Lambert's Point, near Norfolk, Va. Nobody was injured.

(274.) — On September 10 a boiler belonging to the Sun Company exploded in the oil field at Batson, Tex. Fireman W. W. Welder was seriously scalded.

(275.) — On September 12 a boiler exploded in the sawmill of the Camp Manufacturing Co., Dinwiddie county, Va. Fireman Martin was instantly killed, and four other men were seriously injured.

(276.) — A steam cooker exploded, on September 13, in the Gilman Canning Co's plant, at Gilman, near Des Moines, Iowa. Edward Davis, James Grow, Elmer Clark, and Andrew Baker were seriously injured, and it was thought that Davis might not live.

(277.) — The boiler of W. W. Walton's threshing outfit exploded, on September 13, on F. K. Haffey's farm, in Brighton township, near Beaver, Pa. Owie Walton received injuries that were probably fatal, and J. W. Gillespie, Miss Alice Haffey, and F. K. Haffey, Jr., were injured to a lesser extent.

(278.) — A tube ruptured, on September 13, in a water-tube boiler in the plant of the Cayuga Lake Cement Co., Ithaca, N. Y. Nobody was injured.

(279.) — On September 14 a boiler exploded in James T. Plumer's block

mill, four miles from Morehead, Ky. Melville Dye was fatally injured, and the mill was completely wrecked.

(280.) — A tube ruptured, on September 15, in a water-tube boiler at the Avondale Mills, Birmingham, Ala. Fireman M. Smith was scalded, and the boiler was considerably damaged.

(281.) — A slight explosion occurred, on September 16, in the plant of the Citizens' Ice Co., at Altoona, Pa. Nobody was injured.

(282.) — On September 16 a boiler exploded in Anton Seifert's cotton gin, at Weimar, Texas. Fireman John Macha was instantly killed, and Frank Pucklunda was fatally injured. The property loss was estimated at from \$6,000 to \$9,000.

(283.) — A boiler exploded, on September 16, in Edward Jennings' heading and stave mill, at Pinconning, Mich. Charles Easter, William Aplin, Richard Gifford, Albert Bell, and Frederick Nielaus were instantly killed and Albert Jones received injuries which were thought to be fatal. Three other persons were also injured to a lesser extent. The property loss was estimated at about \$4,000.

(284.) — The elbow of a blow-off pipe burst, on September 18, in the municipal water works, Athens, Ga. Fireman H. T. Summers was scalded.

(285.) — A boiler tube exploded, on September 18, in the plant of the United Electric Light and Power Co., on East Twenty-eighth street, New York City. Engineer Matthew Kerr and fireman Patrick Braday were injured.

(286.) — A hot-water boiler exploded, on September 20, in a six family house on Seventeenth street and Eighth avenue, Brooklyn, N. Y. The rear wall of the building was blown out, and three persons were injured.

(287.) — The boiler of a threshing outfit exploded, September 20, two and one-half miles east of New Market, Minn. Olsen Hagen and Andrew Gilbertson were instantly killed, and four other men were more or less severely scalded. One of the injured will lose his sight.

(288.) — A slight explosion occurred, on September 21, between Block Island and Newport, R. I., on the steamer *New Shoreham*, of the Providence and Block Island line. Nobody was injured.

(289.) — A slight boiler explosion occurred on or about September 21, in the Carnegie Lake building, Kingston, N. J.

(290.) — A boiler exploded, September 21, in John Arthur's sawmill, near Stanford, Ind. William Arthur (a son of the owner) received injuries which were believed to be fatal, and two other persons were also injured less severely.

(291.) — On September 21, a boiler exploded in the plant of the Humble Electric Light and Power Co., at Humble, Tex. Fire followed the explosion, and the total property loss was estimated at \$12,000. Nobody was injured.

(292.) — A boiler exploded, on September 21, in Samuel Grossem's cheese factory, at Campbellsport, Wis. The damage was practically confined to the boiler, which was destroyed.

(293.) — The boiler of an ensilage cutting machine exploded, on September 21, on John Marlow's farm, five miles northwest of Salem, Ohio. Mr. Marlow was almost instantly killed, and Joseph Bowman was slightly scalded.

(294.) — A tube ruptured, on September 22, in the plant of the Grand Rapids Gas Light Co., Grand Rapids, Mich. Nobody was hurt.

(295.) — A blow-off pipe ruptured, September 23, in the Green Bay Fiber Co's plant, Green Bay, Wis. Nobody was injured.

(296.) — The boiler of an ensilage cutter exploded, September 23, on the farm of J. P. Mills, of Mills Mills, N. Y. George Beardsley was injured.

(297.) — A slight rupture occurred, on September 24, in a boiler at the plant of the Naperville Lighting and Water Works, Naperville, Ill.

(298.) — A boiler used in connection with the preparation and storage of ensilage exploded, on September 25, on Duane Wilson's farm, at Oneida Lake, N. Y. Fire followed the explosion, and the property loss was estimated at \$2,000.

(299.) — The boiler of a threshing outfit exploded, September 25, on the Moses Wakeman farm, about three miles south of Vestal, N. Y. Dwight Wakeman and John Williams were seriously scalded and burned. Fire followed the explosion, and the property loss was considerable.

(300.) — The boiler of a threshing outfit exploded, September 26, at Charles Sheridan's farm, Hudson Center, Mich. Nobody was hurt.

(301.) — Several sections of a cast-iron sectional heating boiler fractured, on September 26, in the town hall at Torrington, Conn.

(302.) — A slight rupture occurred, on September 27, to the boiler of A. Vaughn & Co., Nashville, Tenn. Nobody was hurt.

(303.) — On September 28 the shell of a digester ruptured in the plant of the West Virginia Pulp & Paper Co., at Mechanicsville, N. Y. Nobody was hurt, and the damage was confined to the digester itself.

(304.) — On or about September 28, the boiler of a threshing outfit belonging to Casper Wojcik exploded near Newhome, N. D. Fireman Alfred Struxness was fatally injured.

(305.) — Several sections of a cast-iron heating boiler fractured, on September 29, in St. Patrick's School, Watertown, Mass. Nobody was injured.

(306.) — The boiler of Edward LaMott's threshing outfit exploded, September 29, at McHenry, N. D. Fireman Olson H. Boyum was severely injured.

(307.) — A small boiler exploded, on September 29, in August Badrow's bakery, on Forty-first street, Galveston, Tex. The damage done was considerable, but nobody was hurt.

(308.) — A boiler exploded, September 29, in George W. Cavin's sawmill, at Nivac, near Nacogdoches, Tex. Portions of the boiler were thrown several hundred yards. Nobody was injured.

OCTOBER, 1905.

(309.) — On or about October 1, a boiler exploded in Musgrove Bros' mill, at Nugent, near Fayette, Ala. Nobody was injured.

(310.) — A slight boiler explosion occurred, on October 2, in the Freeport Light & Power Co's plant, Freeport, Ill.

(311.) — James Rifenburgh, Patrick Mangan, and Benjamin Hermance were killed, and another man named Colego was injured, on October 2, by the explosion of a boiler at Hudson, N. Y. The boiler was used at the water works, for cleaning the sand of the filter beds.

(312.) — A main stop valve ruptured, October 2, in the plant of the Shreveport Gas, Electric Light & Power Co., Shreveport, La. Fireman Richard Guines was injured.

(313.) — A header failed, on October 3, in a water-tube boiler belonging to the Shenango Furnace Co., at Sharpsville, Pa. Nobody was hurt.

(314.) — A boiler exploded, October 4, in E. D. Mulling's sawmill, between Summerton and Summit, near Swainsboro, Ga. One man was instantly killed, two were fatally injured, and three others received lesser injuries. The property lost was about \$1,000.

(315.) — On or about October 5, a boiler exploded in the Hall & Thompson works, at Mesena, Ga. J. W. Thompson (one of the firm) was killed, and Edward Jones was injured.

(316.) — The boiler of a locomotive on the Williamsport & North Branch railroad exploded, on October 6, near Ringdale, Pa. Engineer David Davis was instantly killed, and Fireman Cleon Karschner received injuries which were believed to be fatal. The locomotive was completely wrecked.

(317.) — A tube burst, on October 6, in a water-tube boiler at the United States Cement Co's plant, Bedford, Ind. Fireman W. C. Davis was injured.

(318.) — The cap of a safety valve blew off, on October 6, in the Worcester Salt Co's plant, at Silver Springs, N. Y. Thomas Torrence was scalded.

(319.) — On October 7 a tube ruptured in a water-tube boiler in the Olympia Cotton Mills, Columbia, S. C. The boiler was considerably damaged.

(320.) — A tube ruptured, on October 7, in a water-tube boiler at the Cayuga Lake Cement Co's plant, Portland Point, near Ithaca, N. Y. Fireman Frederick Barnes was scalded.

(321.) — On October 10 a tube failed in a boiler on the U. S. torpedo boat *Stockton*, while she was out from Norfolk, Va., on a five-days' cruise. Michael Marra and Patrick Saulsberry were seriously scalded, and it was thought that the former could not recover.

(322.) — On October 13 a locomotive boiler exploded on the B. B. & B. C. railroad, at Bellingham, Wash. Nobody was seriously injured, although five men were in the cab at the time.

(323.) — The boiler of a threshing outfit exploded, October 13, on the Gemberling farm, one mile southeast of Lancaster, Kans. Harold Olson was killed.

(324.) — An elbow on a blow-off pipe ruptured, October 13, on a boiler belonging to the C. Turner Company, Chicago, Ill. John Snowdon was scalded.

(325.) — A slight boiler explosion occurred, October 15, in the Wichita Union Mill Co's plant, at Wichita, Kans.

(326.) — A rendering tank exploded, on October 15, in the E. J. McDonough packing and slaughter house, Peoria, Ill. The main portion of the tank was projected upward through the roof of the building, and fell some 400 feet from its original position. Nobody was seriously injured.

(327.) — On October 15 there was a slight rupture of a boiler in the plant of the Atlanta Ice & Coal Co., Atlanta, Ga.

(328.) — The boiler used to operate a steam shovel on Thirty-fourth street, New York City, exploded on October 16. Thomas O'Rourke's skull was fractured.

(329.) — Edward Harmon and two other men whose names we have not learned were injured, on October 16, by the explosion of a boiler in the cement works at Bellevue, Mich.

(330.) — The manhole cover of a steam cooker fractured, on October 16, in the National Distilling Co's plant, at Milwaukee, Wis. The property loss was small, and nobody was hurt.

(331.) — A boiler tube ruptured, on October 16, in the basement of the "Flatiron" building, Twenty-third street and Broadway, New York City. Richard Haley and Alfred Lostus were seriously scalded.

(332.) — A hot water boiler exploded, on October 17, in Waverly Hall dormitory, Cambridge, Mass. Mrs. Lillian Edes and her son Arthur, and Mrs. Carrie Liays were injured.

(333.) — On October 18 a tube ruptured in a water-tube boiler in the Allegheny County Light Co's plant, Pittsburg, Pa. Cornelius Murphy was slightly scalded.

(334.) — A boiler exploded, October 19, in Clinton Sturms' sawmill, at Grafton, W. Va. Fireman Jacob Frye was instantly killed, his body being thrown over 200 feet.

(335.) — A main steam valve ruptured, on October 19, in Leo Moser's hotel, St. Louis, Mo.

(336.) — Three cast-iron headers fractured, on October 20, in the American Can Co's plant, at Paulsboro, N. J.

(337.) — A boiler used for operating a cane press exploded, October 21, on the Roettger farm, near Kettlersville, Ohio. Emil Blumhorst was seriously injured.

(338.) — On October 23 a boiler exploded on L. Sachs' farm, four miles west of Jonesboro, Ark. A young man named Sloven was killed, and his father and Park Ostrander were seriously injured.

(339.) — A blow-off pipe exploded, on October 23, in the shops of the New York, New Haven & Hartford railroad, at New Haven, Conn. Harry E. Mannix was killed.

(340.) — The boiler of locomotive No. 239, of the Chicago & Eastern Illinois railroad, exploded, October 24, near the Jackson yards, two miles from Clinton, Ind. Engineer Lemon, fireman Clarence O'Donell, and brakeman John Snyder were seriously injured, and several freight cars were wrecked.

(341.) — A heating boiler exploded, October 24, in the basement of the Aucker building, on Market street, Shamokin, Pa. Mrs. Daniel Eisenhart was injured, and the building was considerably damaged.

(342.) — A cast-iron header fractured, on October 25, in a boiler at the Springstein Mills, Chester, S. C. Nobody was injured.

(343.) — A boiler exploded, October 25, on the dredgeboat *Colorado*, belonging to the Colorado Sand and Gravel Co., off the foot of North Market street, St. Louis, Mo. Engineer Edward Erhardt, Jr., and fireman Robert Bogard were killed, and James Short, George Finch, and Augustus Miller were injured. The boat is said to have been valued at \$35,000. It sank at once, and is reported to be a total loss.

(344.) — On October 26 a boiler exploded in the rear of the Krapf-Bouslog laundry, North Topeka, Kans. Nobody was injured.

(345.) — The boiler of a mogul locomotive exploded, October 27, on the Southern Pacific railroad, two miles east of Yuma, Ariz. Engineer J. W. McClain and fireman R. C. Christensen were killed, and a brakeman whose name we have not learned was injured. The whole superstructure of the locomotive was thrown to a distance of 100 feet, leaving the trucks upon the tracks.

(346.) — Several tubes and headers ruptured, October 29, in a water-tube boiler at the plant of the Topeka Edison Co., Topeka, Kans. The damage was confined to the boiler.

(347.) — The boiler of freight locomotive No. 2052, on the Pennsylvania railroad, exploded, October 29, between Deans and Monmouth Junction, N. J. Fireman Charles H. Eschelmann was killed instantly, and brakeman Charles A. Mervine was injured so badly that he died shortly afterwards. Engineer Henry E. Sterling was also injured seriously, but not fatally.

(348.) — Three cast-iron headers fractured, on October 30, in a water-tube boiler in the plant of the Utah Sugar Co., at Garland, Utah.

(349.) — A boiler exploded, October 30, in a sawmill at Galena, Mo., killing Lee King, and seriously injuring two other men.

(350.) — On October 30 a boiler exploded at the York bridge plant, at Grantley, near York, Pa. Nobody was injured.

(351.) — A cast-iron heating boiler exploded, October 30, in the Third ward school house, at Appleton, Wis. Nobody was injured, and the damage was confined to the boiler and its setting. The janitor states that the pressure, at the time of the explosion, was only a pound and a half.

(352.) — A tube ruptured, October 31, in a water-tube boiler at the East Boston Coal Co's plant, Kingston, Pa.

(353.) — A slight boiler explosion occurred, October 31, on the Longwood plantation of S. J. & Julie Gianelloni, at Manchac, La. The damage was confined to the boiler, and nobody was hurt.

NOVEMBER, 1905.

(354.) — A boiler belonging to P. Becker & Co. exploded, on November 1, seven miles southeast of Lehr, N. D. Jacob Kramer and Audun Reich were killed, and several other persons were injured.

(355.) — A 19-inch steam header ruptured, on November 1, in the Potomac Electric Power Co's plant, at Washington, D. C. William White and Edward Whitney were killed, and George W. Trammell, William Trammell, Harry Hardy, William Hall, Luther Butler, and C. C. Tinstrom were injured. The property loss was about \$1,000.

(356.) — A slight explosion occurred, November 1, in the Anderson Lumber Co's planing mill, at Hudson, Wis. Nobody was injured.

(357.) — A hot-water heating boiler exploded, November 1, in the basement of E. W. Meares & Co's millinery store, at Princeton, Ill. Nobody was hurt.

(358.) — A tube ruptured, on November 2, in a water-tube boiler in the Driver-Harris Wire Co's plant, at Harrison, N. J.

(359.) — On November 2 a tube ruptured in a water-tube boiler in the power plant of the Philadelphia Rapid Transit Co., at Thirty-fifth and Market streets, Philadelphia, Pa.

(360.) — The feed pipe blew out of the head of a boiler in the Buffington Wheel Co's plant, at Burlington, Iowa, on November 2. Fireman B. M. Mad-dox was scalded.

(361.) — The boiler of locomotive No. 416, on the Houston & Texas Central railroad, exploded, on November 3, near Ennis, Tex. Head brakeman Monroe Glenn was instantly killed, and engineer James Davenport died within a few hours. Fireman J. H. Taylor was seriously injured, and the locomotive was almost totally demolished.

(362.) — On November 3 a boiler exploded in Champion Bros' mill, at Varner, Mo. Russ Cunningham, W. M. Bradley, and Peter Newell were seriously injured.

(363.) — A boiler exploded, on November 3, in William H. Casey & Son's sawmill, at Winslow, nine miles south of Petersburg, Ind. William H. Casey and Jacob Deadman were instantly killed, and Lemuel Morton and Rufus Beard were fatally injured. One fragment of the boiler, weighing 70 pounds, was blown 1,000 feet.

(364.) — On November 4 a tube ruptured in a water-tube boiler in the power house of the Public Service Corporation, at Hackensack, N. J. Nobody was injured, and the property loss was small.

(365.) — John Stemmler and Melbourne Tarr were killed, on November 4, by the explosion of a boiler in the plant of the Driggs-Seabury Ordnance Corporation, at Sharon, Pa.

(366.) — A tube ruptured, on November 6, in a water-tube boiler in the Potomac Electric Power Co's plant, at Washington, D. C. Fireman John Sutherland and William Johnson were scalded.

(367.) — On November 8 a tube ruptured in a water-tube boiler in the Coronado Beach Co's hotel, Coronado Beach, Cal. Fireman R. Edwards was injured.

(368.) — Three cast-iron headers fractured, on November 8, in the National Biscuit Co's plant, at Buffalo, N. Y. The property damage was confined to the boiler.

(369.) — A boiler owned by the Queen City Coal Co., and used for operating a coal digger, exploded, on November 9, at Cincinnati, Ohio. Richard Mullen was killed, and Jeremiah Moore and Charles Weber were seriously injured. The coal digger was wrecked.

(370.) — A boiler used for operating an oil well exploded, November 9, on the W. C. Watson farm, in Liberty township, Ohio. Nobody was injured. The main portion of the boiler was thrown to a distance of 300 feet.

(371.) — A boiler used for cleaning out an old oil well exploded, November 10, near Enlow, four miles south of Oakdale, Pa. Pierson Kightlinger and Albert Swoger were injured.

(372.) — On November 10 the boiler of locomotive No. 426, on the Cincinnati, Hamilton & Dayton railroad, exploded at Carthage, Ohio. Engineer Benjamin Laughlin and fireman Herman Habensack were injured, and the locomotive, which was one of the largest on the road, was wrecked. The explosion consisted in the failure of the crown sheet.

(373.) — A boiler exploded, November 10, in Josiah Ricker's sawmill, at Midvale, N. J. Daniel Beatty was instantly killed and Josiah Rodner and the proprietor of the mill were injured.

(374.) — A boiler exploded, on November 13, in Joel Baumgartner's flouring mill, at Guttenberg, Clayton county, Iowa. The owner of the mill and his engineer, Benjamin Walter, were killed, and the building in which the boiler stood was completely wrecked.

(375.) — A blow-off tank exploded, on November 14, at the plant of the Baltimore Refrigerating & Heating Co., Baltimore, Md. Nobody was injured. Three dwelling houses across the street from the place of the accident were considerably damaged.

(376.) — A slight boiler explosion occurred, November 15, in the factory of the Dr. Miles Medical Co., at Elkhart, Ind. John Kuszmaul was injured.

(377.) — On November 16 a boiler used for operating an oil well exploded on the Sauer farm, Allegheny county, Pa. Edward Young and W. Steinmetz were injured.

(378.) — The boiler of locomotive No. 198, on the Cotton Belt line, exploded, November 16, one mile north of Antrim, La. Fireman A. L. Townsend was slightly scalded.

(379.) — A slight explosion occurred, on November 16, in the heating boiler of the city prison at Springfield, Ohio. Nobody was hurt, and the property damage was trifling.

(380.) — The boiler of Morris' portable sawmill exploded, on November 16,

five miles southeast of Beaverton, Mich. Engineer Frank Burns received injuries which were thought to be fatal, and Andrew Coyle, Albert Mitchell, and a man named Smith received lesser injuries. The sawmill was wrecked.

(381.) — The boiler of locomotive No. 608, on the Santa Fe railroad, exploded, November 17, at Edelstein, near Chillicothe, Ill. Engineer Wirt Pence and fireman James Clemenson were injured.

(382.) — On November 18 a boiler exploded in Clinton Sturm's sawmill, at Millersville, near Knottsville, W. Va. Fireman Jacob Frye was instantly killed.

(383.) — A boiler exploded, November 20, on the Hope penal farm, Jeanerette, La. One of the convicts, whose name we have not learned, was seriously injured.

(384.) — A boiler exploded, November 20, in the steel plant at New Philadelphia, Ohio. Charles Stahl, the night superintendent, was seriously injured.

(385.) — On November 20 a boiler exploded in Mangum & Magee's sawmill three miles northeast of Groveton, Tex. William Mourning was instantly killed and Solomon Mangum, Sherman Sanders, and Clinton James were injured.

(386.) — On November 21 a slight explosion occurred in the plant of the Ruston Oil Mills & Fertilizer Co., at Ruston, La. Nobody was injured.

(387.) — Two boilers exploded, on November 21, in an electric lighting plant, planing mill, sawmill, and cotton gin, at Arcadia, La. Fireman Thomas Vaughn was badly injured.

(388.) — A tube ruptured, on November 21, in a water-tube boiler at the power plant of the Brooklyn Heights Railroad Co., Thirty-ninth street, Brooklyn, N. Y. Fireman H. Ackins was scalded.

(389.) — A blowoff ruptured, November 21, in the S. A. Wood Machine Co.'s plant, South Boston, slightly injuring Walter Seeley.

(390.) — Four cast-iron headers fractured, November 22, in the American Car & Foundry Co.'s plant, Berwick, Pa. Nobody was hurt.

(391.) — On November 23 the mud drum of a water-tube boiler was blown off of the tubes in the plant of the Le Grange Service Co., at Le Grange, Ill. Fireman Frank Dhooche was severely burned.

(392.) — A boiler exploded, November 24, in the Portland Cement Co.'s plant, at Syracuse, Ind. John L. Lecount was scalded badly and perhaps fatally.

(393.) — On November 24 a boiler exploded in Wilharms Bros' flouring mill, at Greenleaf, Wis. William Wilharms was killed.

(394.) — A tube ruptured, November 26, in a water-tube boiler at the blast furnace of the Salem Iron Co., Leetonia, Ohio.

(395.) — Two sectional boilers exploded, November 27, in the Ritger hotel, at Appleton, Wis. The building was crowded with guests at the time, but fortunately all escaped injury.

(396.) — On November 27 a tube ruptured in a water-tube boiler at the plant of the New York Belting & Packing Co., Passaic, N. J.

(397.) — A tube ruptured, November 27, in a water-tube boiler at the plant of the Columbia Chemical Co., Barberton, Ohio. I. Heikes was scalded, and the boiler was considerably damaged.

(398.) — A slight boiler explosion occurred, on November 30, in the Pennsylvania Steel Company's plant, at Steelton, Pa. One man was killed, and three others were injured.

(399.) — On November 30 a tube gave way in a Delaware & Hudson locomotive, at Unadilla, N. Y. Samuel Mooney was burned so badly that he died a fortnight later. Another man named Whitney was also injured, but not fatally.

DECEMBER, 1905.

(400.) — A blow-off pipe ruptured, December 3, in the Lake Erie Provision Company's plant, at Cleveland, Ohio. Fireman William Boberg was injured.

(401.) — On December 4 a boiler exploded in the machine shop of the Hilton & Dodge Lumber Company, Belfast, Ga. Frank Isanhower was badly burned, and the boiler room was demolished.

(402.) — The back head of a horizontal tubular boiler cracked on December 6, in the Dexter Sulphite Pulp & Paper Company's Frontenac mill, at Dexter, N. Y. Nobody was injured.

(403.) — Two cast-iron headers fractured, on December 4, in a water-tube boiler at the Hammermill Paper Company's plant, Erie, Pa. Nobody was injured, and the property loss was confined to the boiler.

(404.) — On December 4 a slight fracture occurred in a vertical boiler at the plant of the Boston Forge Company, East Boston, Mass. Nobody was hurt.

(405.) — Two boilers exploded, on December 6, during the course of a fire at the plant of the Trimount Wrench Company, Roxbury, Mass. Nobody was injured by the boiler explosions.

(406.) — A boiler used in connection with an oil well exploded, on December 6, on the Henry Becker farm, two miles below Lowell, Ohio. Arthur Hovis was seriously injured.

(407.) — A slight explosion occurred, on December 6, in the plant of the Canby, Ach & Canby Co., at Dayton, Ohio. Engineer J. E. Hunt was slightly scalded, and the machinery about the place was considerably damaged.

(408.) — On December 6 a boiler exploded in the state penitentiary at Leavenworth, Kans. Nobody was hurt, but the boiler was ruined, and other machinery was considerably damaged.

(409.) — A boiler exploded, December 8, in a sawmill at Varner, Ark. Several persons were injured.

(410.) — A boiler exploded, December 8, at the Fairbanks quarry, Marion, Ohio. Joseph Goon was killed instantly, and Henry Hocter and William Philippi were injured so seriously that they both died within a few days.

(411.) — On December 9 a boiler explosion occurred in R. L. Dowling's mill, at Live Oak, Fla. Nobody was injured.

(412.) — Herbert A. Shannon and J. E. Turner were instantly killed, on December 10, by the explosion of a boiler on the Mary E. Burghart oil lease, seven miles southeast of Chanute, Kans.

(413.) — On December 11 a boiler exploded in the Western Wooden Ware Cooperage Works, at Angola, Ind. Engineer Perry Stillwell was badly scalded and otherwise injured.

(414.) — A hot-water heating boiler exploded, December 11 in the residence of Joseph Bach, Jr., 2500 Grand Ave., Milwaukee, Wis. Mr. Bach was seriously scalded.

(415.) — A heater exploded, on December 12, in the plant of the Sidney Pole & Shaft Company, Sidney, Ohio. Engineer William Neth was injured so badly that he died on the following day.

(416.) — The boiler of Recker Bros.' sawmill exploded December 13, at New Cleveland, near Columbus Grove, Ohio. Henry Recker (one of the owners) was killed outright, and his brother, Bernard Recker, was injured so severely that it was thought he might not recover. C. O. Wishmeyer and John Laubenthal were also severely injured.

(417.) — On December 13 a boiler exploded in Lane, Burriss & Wade's sawmill and shingle mill, eight miles northwest of Cookeville, Tenn. Andrew Lane and Robert Wade were instantly killed, and the entire plant was wrecked.

(418.) — A cast-iron mud drum, belonging to a water-tube boiler, fractured, on December 13, in the Beaver Valley Traction Company's plant, at Beaver Falls, Pa.

(419.) — On December 13 a tube ruptured in a water-tube boiler in the power house of the Philadelphia Rapid Transit Company, 33rd and Market streets, Philadelphia, Pa. Nobody was hurt, and the property loss was small.

(420.) — An upright heating boiler exploded, on December 14, in a building on the northeast corner of St. George and College streets, Toronto, Ont. The total property loss was estimated at \$2,300. We have not learned of any personal injuries.

(421.) — Two heating boilers exploded, on December 14, in the McClelland school building, at Springfield, Ill., seven sections giving out in one of the boilers, and four in the other. Nobody was hurt.

(422.) — A slight boiler explosion occurred, December 14, in Hutchinson & Johnson's heading factory, at Jonesboro, Ark. Fireman Otto Duty was badly scalded, but it was thought that he would recover.

(423.) — On December 14 a boiler exploded in the tannery of Roach Bros., at Kingston, N. Y. Engineer Frank Smith was badly scalded. The building in which the boiler stood was not much injured, but the boiler, after leaving it, passed over a five-story building near by, struck the Weston building, 300 feet from the tannery, and damaged it badly.

(424.) — A tube exploded, on December 15, in a water-tube boiler in the

round-house of the New York Central railroad, at West Albany, N. Y. William C. Travis, Edward Addick, Charles Scanlon, and Wasco Leserick were seriously burned and scalded.

(425.) — On December 17 a tube exploded in a water-tube boiler, in the Pittsburg Gas & Coke Company's plant, at Otto station, near Pittsburg, Pa. George Salvey was injured so badly that he died within a short time, and John Meklas was injured seriously, but not fatally. The property loss was small.

(426.) — A boiler exploded, on December 18, at the Spring River Mining Company's plant, Stotts City, Mo. Engineer Pates was instantly killed, and a boy who was near by was badly scalded and otherwise injured, though it was thought that he might recover. The building in which the boiler stood was almost entirely wrecked.

(427.) — On December 18 a boiler exploded in the Franklin Machine Company's plant, at Providence, R. I. The accident occurred at 11:15 p. m., and nobody was injured. The property loss was estimated at \$4,000. (This is the explosion that the so-called "prophetess," Mrs. Fay, claims to have predicted.)

(428.) — A steam heating boiler exploded, December 19, in the basement of a brick dwelling house at 91 Claremont avenue, Jersey City, N. J. Nobody was injured.

(429.) — The boiler of a locomotive exploded, December 19, on the Reading railroad, between Birdsboro and Joanna, Pa. Engineer H. W. Leinbach, fireman William T. Hesser, and brakeman W. T. Alderman were killed. The boiler was lifted bodily from the frame, and hurled into the woods.

(430.) — A boiler exploded, on December 22, in the James Veatch sawmill, on Big Drywood creek, in the southwestern part of Vernon county, Mo. Robert Wilson was killed, and Mr. Veatch, the owner, was seriously injured. Another man, whose name we have not learned, also received minor injuries.

(431.) — On December 22 the boiler of a locomotive exploded on the Lehigh Valley railroad, half a mile east of Vanctten, N. Y. Henry McMann and Leon Dennison were injured so badly that they died within two hours. Conductor Martin Gallagher, engineer Frederick Swarthout, and fireman Frank Morse were also seriously injured, but it is believed that all three will recover. Mr. McMann was a brakeman, and Mr. Dennison a freight handler.

(432.) — On December 22 a flange cracked on a blow-off pipe, in K. Frederick's distillery, at Harrison, Ohio. George H. Frederick, the general manager, was badly burned.

(433.) — A blow-off pipe fractured, on December 23, in an apartment house belonging to E. A. Burgess, at Sioux City, Iowa. Fireman B. S. Bunton was seriously scalded and burned.

(434.) — The boiler of a locomotive on the Susquehanna railroad exploded, December 25, near North Paterson, N. J. Fireman Charles LaBarr and conductor Mabie were seriously burned and scalded. The whole lower part of the locomotive was wrecked, and the sound of the explosion was heard for several miles.

(435.) — A slight boiler explosion occurred, December 26, in the Parkersburg mill, at Parkersburg, W. Va. Nobody was injured.

(436.)—A tube ruptured, December 26, in a water-tube boiler at the plant of the National Sewing Machine Company, Belvidere, Ill. Anthony Gallagher and James Leonard were severely scalded.

(437.)—A boiler exploded, December 27, at the boys' farm, near Hudson, Ohio. Nobody was injured.

(438.)—A blow-off pipe ruptured, December 27, in the store of Henry Sonneborn & Co., Baltimore, Md. Nobody was injured. The property loss is estimated at about \$900.

(439.)—On December 27 a tube failed in a water-tube boiler in the puddling department of the Duncannon Iron Works, Duncannon, Pa. William Hilbush was injured so badly that he subsequently died. Hugh Quigley and Robert Baringer were also injured seriously, but not fatally.

(440.)—A boiler exploded, December 29, in the rear of the Porter block, at Niagara Falls, N. Y. Fire followed the explosion, and the total property loss, from the explosion and the fire, was about \$100,000.

(441.)—A tube failed, on December 29, in a water-tube boiler at the plant of the Alsens American Portland Cement Company, Alsens, N. Y. Charles Lorni was seriously injured, and Jacob Edsick was injured slightly.

(442.)—A locomotive boiler exploded, December 29, on the Chicago & Erie railroad, at Disko, Ind. Engineer John O'Brien, fireman Cecil Oliver, and brakeman Lemuel Fisher were instantly killed, and the train was wrecked.

(443.)—On December 30 a tube ruptured in a water-tube boiler in the Philadelphia Rapid Transit Company's power plant, at 33rd and Market streets, Philadelphia, Pa. Nobody was injured.

(444.)—A boiler exploded, December 30, in the conservatory of John M. Champion, at New Haven, Conn. Nobody was injured. The property loss was estimated at \$4,000.

Boiler Explosions during 1905.

We present, herewith, our usual annual summary of boiler explosions, giving a tabulated statement of the number of explosions that have occurred in the United States (and adjacent parts of Canada and Mexico) during the year 1905, together with the number of persons killed and injured by them. We desire to say, once more, that it is by no means easy to make out accurate lists of boiler explosions, because the accounts that we receive are often unsatisfactory, but, as usual, we have spared no pains to make the present summary as nearly correct as possible. In preparing the detailed monthly lists upon which it is based (and which are published regularly in *THE LOCOMOTIVE*), it is our custom to obtain as many distinct accounts of each explosion as possible, and then to compare these different accounts diligently, in order that the general facts may be stated with considerable degree of accuracy. We do not pretend that this summary includes all of the boiler explosions for 1905. In fact, it is likely that only a fraction of these explosions are here represented; for many accidents have doubtless occurred that were not consid-

ered by the newspapers to be sufficiently "newsy" to interest the general public. We believe, however, that most of the boiler explosions that have attracted any considerable amount of attention are here represented.

The total number of boiler explosions in 1905, according to the best information we have been able to obtain, was 450, which is 59 more than were recorded for 1904. There were 391 in 1904, 383 in 1903, 391 in 1902, and 423 in 1901. In several instances during the year 1905 two or more boilers have exploded simultaneously. In every case of this sort we have followed the practice of several years past, and counted each boiler separately in making out the summary, believing that by so doing we should represent the actual damage more accurately than we should if we simply recorded the number of separate occasions on which boilers have exploded.

The number of persons killed in 1905 was 383, against 220 in 1904, 293 in 1903, 304 in 1902, and 312 in 1901; and the number of persons injured in 1905 was 585, against 394 in 1904, 522 in 1903, 529 in 1902, and 646 in 1901.

SUMMARY OF BOILER EXPLOSIONS FOR 1905.

MONTH.	Number of Explosions.	Persons Killed.	Persons Injured.	Total of Killed and Injured.
January,	52	45	48	93
February,	38	18	40	58
March,	29	83	157	240
April,	24	10	18	28
May,	29	21	23	44
June,	25	17	34	51
July,	38	87	78	165
August,	32	18	29	47
September,	43	20	39	59
October,	45	20	35	55
November,	48	22	50	72
December,	47	22	34	56
Totals,	450	383	585	968

The average number of persons killed, per explosion, during 1905, was 0.851, and the average number of persons injured but not killed, per explosion, was 1.300.

The year 1905 was signalized by two particularly disastrous boiler explosions. The first of these was the fearful explosion in the factory of the R. B. Grover Company, manufacturers of the Emerson shoe, at Brockton, Mass., which occurred on March 20, 1905, and resulted in the death of 58 persons, and the more or less serious injury of 117 others. The second was the almost equally appalling explosion which occurred, on July 21, on the U. S. gunboat *Bennington*, while she was lying in the harbor of San Diego, Cal. The *Bennington* explosion resulted in the death of 62 persons, and in injury to 40 others. The Brockton explosion was described at some length in the issue of THE LOCOMOTIVE for April, 1905, and the *Bennington* explosion is described (so far as the available data will permit) in the present issue.

The Locomotive.

A. D. RISTEEN, PH.D., EDITOR.

HARTFORD, JANUARY 15, 1906.

THE LOCOMOTIVE can be obtained free by calling at any of the company's agencies.
 Subscription price 50 cents per year when mailed from this office.
 Bound volumes one dollar each. (Any volume can be supplied.)

Obituary.

MR. WILLIAM MOST.

On November 28, 1905, the steamship *Mataafa* was lost, during the course of a severe storm, on Lake Superior, near Duluth, Minnesota. Nine members of the crew were drowned, including William Most, the chief engineer. Mr. Most had been inspector for the Hartford Steam Boiler Inspection and Insurance Company, in the Northern Ohio department, with headquarters at Cleveland. He entered our employ on April 1st, 1902, and continued with us until April 1st, 1904, when he left to accept the position that he held at the time of his death. He was thirty-seven years of age, and had followed the great lakes since his seventeenth year, except for the two years noted above. Mr. Most was exceptionally well versed in steam engineering, and was highly esteemed both for his knowledge and skill, and for his delightful personality, which endeared him to all his associates.

On January 1, Mr. Fred H. Williams, Jr., became associated with the Hartford Steam Boiler Inspection and Insurance Company, as Special Agent, with headquarters at Hartford. Mr. Williams is already widely acquainted in his territory, as he is a native of Hartford, and has also had some years of experience "on the road." We commend him heartily to the present and prospective patrons of this company.

ACCORDING to the daily papers, Mrs. Eva Fay, who gives mystifying and very clever public entertainments suggestive of the possession of occult powers, frightened the credulous portion of the population of Providence, R. I., by predicting a boiler explosion for that city. The affair appears to have been a somewhat serious one for the merchants of Providence, as the explosion was supposed to be due in a department store, during the week preceding Christmas, and it is reported that many shoppers, remembering the terrible explosion at Brockton, went to Boston to do their holiday shopping. One big Providence store (The O'Gorman Co.) printed a big advertisement consisting of the following announcement in heavy-faced type: "No steam is used in the big store this week. Our fires are drawn; our boilers shut down; our elevators are run by electricity supplied by the Narragansett Electric Light Co. We have done this not from any fear of accident, but because of the many absurd rumors

in circulation regarding a so-called 'prophecy,' and in order to relieve the minds of the credulous."

The nearest approach to fulfilment of the "prophecy" consisted in the explosion of a boiler in the Franklin Machine Company's plant, of Providence, at 11.15 p. m., on December 18. Nobody was injured, but the property loss was estimated at \$4,000. A slight explosion also occurred in a jewelry shop on December 23, when two men were injured, and the police had difficulty in preventing girls (seven of whom fainted) from jumping from fourth story windows to the street.

In these days of education and enlightenment it ought to be impossible to frighten anyone by predictions of this sort, or any other sort. In view of the fact that timid ones *are* frightened, however, we are of the opinion that those who pretend to the possession of occult powers, or those who give similar entertainments without pretending anything at all, would show far better judgment to confine their attention to the performance of card tricks, the reading of sealed writings, and the exhibition of other manifestly innocent and harmless feats.

IN the issue of THE LOCOMOTIVE for October, 1905, we called attention to an article which was printed in our highly esteemed contemporary, the *Youth's Companion*. We criticised the *Companion*, mainly because to the true part of the tale (which was taken from THE LOCOMOTIVE) it had appended a purely imaginary sequel. We have since received an explanation from the editors of the *Companion*, in which it is made plain that the article in question was prepared and inserted without proper authority from the responsible editors. We are also assured that it is the intention of the management of that excellent paper, to have the matter that it prints well-authenticated in all respects. In view of this explanation (which is in entire accord with our own previous belief of many years' standing), we desire to express our sincere regret that we published any criticism at all; for "even the worthy Homer sometimes nods."

The Boiler Explosion on the "Bennington".

The terrible boiler explosion which occurred, on July 21, on the U. S. gunboat *Bennington*, has been the subject of a protracted official investigation by the Navy Department, and we have thought it only courteous to the Department to defer the publication of any extended account of the disaster, until the completion of the official proceedings. It appears likely, at the present writing, that no further action is to be taken; and hence we present the following account of the accident, which gives the general facts so far as they can be gathered from the data that are available.

The *Bennington* was authorized by Congress on March 3, 1887, and was built by N. F. Palmer & Company, of Chester, Pa., the successors of John Roach. Her keel was laid in June, 1888, and she was launched on June 3, 1890, and commissioned for the first time on June 20, 1891. She was classed as a gunboat, and her hull was constructed of steel, with a single bottom. Her displacement was 1,710 tons, and her main battery consisted of six 6-inch breech-loading rifles, and

her secondary battery of four 6-pounders, four 1-pounder rapid-firing guns, and two 30-caliber Colt guns.

The engines of the *Bennington* were horizontal, triple expansion, and operated two screws. The cylinders were 22, 31, and 50 inches in diameter, respectively, with a stroke of 30 inches. The maximum indicated horse power developed was 3,392, and the estimated speed attained on the trial trip was 17.5 knots per hour. The total weight of her machinery was 282.65 tons, and her coal bunkers had a capacity of 391 tons, with a coal endurance (at a speed of ten knots per hour) of 4,262 knots.

The *Bennington* had four cylindrical straight-way boilers, commonly known as locomotive gunboat boilers, each 17 ft. 9 in. long and 9 ft. 9 in. in diameter. Each of these boilers had three furnaces, with one combustion chamber, which was divided into three parts by a transverse arch of firebrick, and a longitudinal wall built on the crown of the arch and between the nests of tubes. There was a hanging bridge-wall in each of the divisions of the combustion chamber. Each combustion chamber was 45 inches deep (that is, lengthwise of the boiler), and 8 ft. 10 in. in extreme width. The main shell-plates of the boilers were 13/16 in. in thickness, the tube-sheets were 9/16 in. thick, and the front head was 3/4 in. thick.

The longitudinal joints of the shells were butted and double riveted, with straps inside and out, and the girth joints were lapped and double riveted. The rivets were 1 inch in diameter. Each boiler had fifteen fore-and-aft braces 2 1/4 in. in diameter. Each boiler had a heating surface of 2,053 sq. ft., a grate area of 55 sq. ft., a water surface of 149.5 sq. ft., a steam space of 328 cu. ft., and a free area through the tubes of 9.42 sq. ft. Each boiler weighed 26.68 tons when empty, and 41.66 tons when filled with water to the normal level.

We have no information as to the diameter and thickness of the furnaces and tubes of the *Bennington's* boilers, but the boilers of the *Bennington* and *Yorktown* are supposed to be identical, and they are so, so far as we have been able to compare the two. The *Yorktown* has corrugated furnaces 41 in. in diameter outside and 37 in. inside, and the furnaces are one-half an inch thick. Of the *Yorktown's* 438 tubes, all are 2 1/4 in. in diameter externally, and 370 are No. 11 B. W. G. in thickness, while the remaining 68 are No. 6 on the same gauge, and are spaced as uniformly as practicable among the others, so as to give additional staying support to the tube sheets. We presume, in the absence of information to the contrary, that the *Bennington's* furnaces and tubes were substantially the same as here described. (The boilers of the *Yorktown* are illustrated in *Engineering* (London) for April 24, 1891, page 493.)

The *Bennington's* boilers (four in number) were placed in two separate water-tight compartments. In each fire-room there were two blowers for producing forced draft, these drawing air from the fire-rooms and discharging it into ducts which led to the ash-pit fronts and door frames. One of the blowers in the after fire room was arranged to draw air from the engine-room or fire-room, as might be desired. There was one smoke stack, 7 ft. in diameter and 57 ft. 6 in. high, for the four boilers; the uptakes from each pair uniting above the water-tight bulkheads between the fire-rooms.

The boilers were originally designed (it is said) for a steam pressure of 160 lbs. per square inch; but the pressure had been reduced to 135 or 140 lbs. for cruising, the safety valves being set to blow at 145 lbs. The boilers were re-tubed in 1903-1904, and we understand that temporary repairs of some character were made upon the boilers in May, 1905, at the Mare Island Navy Yard.

The *Bennington* has been used mainly in Pacific waters, and her last service previous to the explosion was at the Hawaiian Islands. She sailed from Honolulu on July 7, proceeding to San Diego, Cal., where she arrived on July 19. The monitor *Wyoming* having just dropped one of her propellers near Port Harford, Cal., and become unmanageable, the *Bennington* was ordered to go to her assistance, and see her safely into San Francisco. The *Bennington* was to sail for this purpose on July 21, and on that day she was lying in the stream at San Diego, just off the Commercial wharf at H street, nearly ready to depart, when the disastrous explosion occurred. Commander Lucien Young says, in his telegram to the Navy Department announcing the explosion, "At 10:30 this morning, while making preparations for getting under way with all hands at their stations, the top of the lower furnace of boiler B exploded, forcing the boiler astern in contact with boiler D, which was also forced astern, and exploded." If we understand the phraseology correctly, it would imply that the initial rupture consisted in the failure of the lower furnace of the forward starboard boiler, by collapse from above downward, and that the boiler so affected was thrown violently astern, so that it came into collision with the aft starboard boiler, and caused that to explode also. (See, however, the Report of the Court of Inquiry, subsequently given.) Commander Young was ashore at the time, but the discipline appears to have been excellent, and the magazines were promptly flooded, and steps were at once taken to rescue the injured. Sections of the upper deck were carried away and a hole was blown in the side of the vessel, through which water entered, causing a rapid listing to starboard. The vessel was at first said to be almost totally wrecked, but she was subsequently found to be "practically uninjured except in and about the boiler and engine-room." By the assistance of other craft she was beached on a mud bank, between two wharves.

The total number of persons killed was 62, counting those killed outright and those that died within a short time. In addition, there were 14 who were seriously injured and 26 others who were injured less seriously. The ship's complement of men numbered 197, including officers and crew, so that it appears that more than half (namely, 102,) of the men were killed or injured. We shall not attempt to give any account whatever of the scenes of horror that prevailed upon the fated ship. Commander Young stated that not even the leper settlement at Molokai, in the Hawaiian Islands, could show anything so fearful.

Secretary of the Navy Charles J. Bonaparte made the very reasonable request that judgment as to the responsibility for the disaster be suspended until an official investigation could be made. He said: "I promise the public that nobody shall be whitewashed, and the Service that nobody shall be made a scapegoat." A Court of Inquiry was appointed to investigate the explosion, and this began its work at San Diego on July 28. The Court consisted of Commander Holland N. Stevenson, Captain Thomas S. Phelps, and Captain Edwin K. Moore. The finding of the Court reached the Navy Department on August 21, and was made public on August 22. From this report it appears that when the orders to sail for Port Harford were received, the boilers and engines of the *Bennington* were being overhauled, preparatory to an expected voyage to Panama. Boilers *A* and *B* were ordered to be filled with fresh water. Fires were started in the lower furnaces of these two boilers (the remaining boilers being already under steam) at about 8 o'clock on the morning of July 21, and at about 9:15 fires were started also in the wing furnaces of *A* and *B*.

What followed is best given in the precise words of the Court, which found: "That at about twenty minutes after nine o'clock, a. m., the steam gauge on boiler

B showed about five pounds of steam pressure, and at this time Oiler Frank De Courtani, acting as water tender, directed D. H. Holland, fireman, second class, to close the air cock on boiler *B*; that the said Holland climbed up and closed a valve, and almost immediately the steam gauge on boiler *B* failed to register any pressure; that this was apparently not noticed by either the water tender or the fireman, and no attention appears to have been paid to the fact that the steam gauge failed to register, but they kept on working the fires and firing heavily; that when the steam gauge on boiler *A* showed one hundred and thirty-five pounds there was no pressure showing on the steam gauge of boiler *B*.

"That at about a quarter to ten o'clock, a. m., the engines were turned over, using steam from boilers *C* and *D*; that as it was not thought that steam would be ready in boilers *A* and *B* before early in the afternoon, it had been decided to get under way and leave the harbor under boilers *C* and *D*, but steam appears to have formed much more rapidly than it was thought possible it could be formed, and boiler *A* was connected with boilers *C* and *D* at about twenty minutes after ten o'clock, a. m.; that no pressure was showing on the steam gauge of boiler *B* at this time.

"That at about this time a small leak developed in No. 1 furnace of boiler *B*, and coal passer A. J. Worthen was sent on deck by De Courtani, the acting water tender, to inform the boiler maker about the leak and request him to come below and attend to the same; and just about this time, as Worthen was leaving Dustin, the boiler maker (who was, we believe, on the berth deck), the explosion occurred.

"That the lower corrugated furnace flue of boiler *B* collapsed throughout its entire length on top, and partly so on its bottom, which caused boiler *B* to break from its saddles, forcing the boiler aft through a bulkhead and against boiler *D* which also broke from its saddles, both boilers moving aft, until boiler *D*, after having broken through the engine room bulkhead, brought up against the forward engine framing, boiler *B* having moved aft about fourteen feet from its original position, breaking all steam connections of all the boilers, allowing the steam from the four boilers to escape into the ship, also breaking many sea-water connections, in the fire rooms and engine room, giving water access to the ship, and disabling everything in the boiler and engine-rooms; that steam escaped with terrific force into almost all parts of the ship, carrying with it water, ashes, and coal, killing or wounding 51.45 per cent. of the officers and crew, and damaging almost everything throughout the ship."

It is but natural to ask why the safety-valve did not blow upon boiler *B*, under the circumstances so plainly indicated. Upon this point the finding of the Court was: "That no one seemed to have noticed any escape of steam from the safety-valves of any of the boilers, and no one can state that any of the safety-valves blew off at any time that morning. That we can find no record of the safety-valve of boiler *B* having been overhauled since July, 1904, nor any positive evidence of its having been done, though orders had been given for this to be done in March, 1905; that there is no record of the sentinel valve having been overhauled since July, 1904; that the safety-valves were set at 145 pounds, but en route from Honolulu to this port orders were given to carry the steam pressure at from 130 to 135 pounds, and not to exceed the latter, but the safety-valves were not changed; that this order had been clearly understood; that the hand gear for lifting the safety-valves was not in working order, and there is no record or direct evidence that the safety-valves had been tested in accordance with the Navy Regulations."

Summing up the evidence as to the cause of the explosion, the Court says: "The Court is of the opinion that the explosion was caused by excessive steam pressure in boiler *B*, which came about first by shutting the valve connecting the boiler with the steam gauge, instead of the valve on the air cock alone as was intended, so that the steam gauge did not indicate the pressure in the boiler; second, by unusual and heavy firing in the boiler, to get up a pressure which the gauge failed to show; third, by the failure of the sentinel and safety-valves to lift at the pressure at which they were set, and the pressure increased without relief until it was beyond the strength of the boiler, which gave way in its weakest part, afterward found to be the corrugated flue of No. 2, the lowest or middle furnace of which collapsed."

The Court found "that the ship was in an excellent state of discipline, and in a good and efficient condition, with the exception of her boilers, which were in fair condition and efficient considering their age (fourteen years) and the use to which they had been subjected." Fireman D. N. Holland is held responsible for closing the valve to the pressure gauge instead of the air cock as was indicated; Oiler Frank De Courtani is held responsible for pushing the fires without noting that the gauge did not respond, and for not immediately taking steps to relieve the boiler as soon as distress was shown; and Chief Machinist's Mate E. B. Ferguson, on watch in charge of the engine and fire rooms, is held responsible for failure to exercise due supervision during the raising of the pressure upon boiler *B*. All three of these men are dead, however, so that proceedings against them are impossible.

The only person still living, who appears to have been censured by the Court, is Ensign Charles T. Wade, who was in charge of the engineering department of the *Bennington*. It was recommended that Ensign Wade be court-martialed, on the grounds (1) that he failed to see to it personally that the safety-valve on the boiler was overhauled at the proper time and kept in good working order, but accepted the oral statement of one or more of his subordinates that it had been overhauled in March, 1905; (2) that he failed to keep the sentinel valve in good working order; and (3) that he failed to have the safety and sentinel valves on all the boilers tested in accordance with the Navy Regulations.

In reviewing the findings of the Court of Inquiry, under date of August 29, Secretary of the Navy Bonaparte approves the findings of fact, except in regard to the paragraph stating that "the ship was in an excellent state of discipline and in a good and efficient condition, with the exception of her boilers, etc." Concerning this paragraph the Secretary says: "The Department does not consider this particular finding sustained by the evidence; the proof tends strongly to show that the enlisted force of the engineering division had been permitted to fall into habits of laxity and inattention in the discharge of their duties, and that at least some of this force were also imperfectly instructed regarding their duties. In the view of the Department, the evidence establishes, further, that certain appurtenances, to wit, the safety and sentinel valves of at least one of the boilers, were not in an efficient condition at the date mentioned, and had not been in such condition for a considerable time previously, and, in the judgment of the Department, this evidence renders the statements that the ship was in a 'good and efficient condition,' and that her boilers were in 'fair condition and efficient,' inappropriate to the facts disclosed by the proof."

The Secretary commended, very cordially, the "highly creditable conduct of all the survivors of the officers and crew of the *Bennington*, after the explosion occurred," and he especially mentioned that he desired to include in this commend-

ation Commander Lucien Young, and Ensign Charles T. Wade. The Secretary nevertheless approved of the recommendation of the Court that Ensign Wade be tried by court-martial. He also said: "Inasmuch as the Court of Inquiry did not pass expressly in its findings and opinion upon the conduct of Commander Lucien Young, U. S. N., commanding the U. S. S. *Bennington*, and the question of his responsibility for the explosion thereon and the consequent loss of life and injuries to persons and property, the Department must treat this silence as an implied finding that he was not thus responsible. After very careful consideration, the Department is compelled to disapprove this implied finding. . . . The foregoing provisions of the Regulations, and the facts disclosed by the Report of the Court of Inquiry and by the testimony and exhibits thereto attached, make it the duty of the Department to require Commander Lucien Young, U. S. N., to clear himself, before a general court-martial, of the charge of neglect of his official duty above indicated. Such court-martial is, therefore, ordered."

In accordance with the order here indicated, court-martial proceedings were instituted against Commander Lucien Young and Ensign Charles T. Wade, at the Mare Island Navy Yard, California, with Captain Ernest E. West as Judge Advocate. The first meeting was held on Friday, September 15. This, however, was only a formal meeting, to fulfil the requirements of the Department. The regular sessions began on Monday, September 18, on which date Commander Young pleaded "not guilty." Commander Young was represented at the proceedings by Judge George D. Gear, of Honolulu, a personal friend, who came on from Honolulu especially to conduct the defense. After being in session for about a week, the court-martial adjourned on account of the illness of Ensign Charles T. Wade, who was needed as a witness. The sittings were resumed on October 9, and the prosecution closed its case on October 18. The defense was immediately begun, and on October 25 the court-martial proceedings against Commander Young came to an end. The finding of the court was transmitted to Secretary Bonaparte, who held it under consideration until the early part of January. On January 6 the Secretary addressed a letter of censure to Commander Young, in which he refers to Young's "brilliant services in the past," and his "merited reputation for seamanship and gallantry," and says: "The court-martial by which you were tried has convicted you of remissness in the discharge of your official duty in that you failed to sign the smooth steam log of the U. S. S. *Bennington* while that vessel was under your command, as required by the Regulations for the government of the Navy; for such remissness its sentence is that you be reprimanded by the Secretary of the Navy."

Commander Young's failure to sign the log has but slight bearing, apparently, upon the accident to the *Bennington*.

Ensign Wade's trial was begun on October 30, before the same Court that tried Commander Young. It lasted but a few days, and resulted in the young man's acquittal.

We certainly have no disposition to lay the blame for the explosion upon Commander Young, and it may be that the men who were actually responsible for it were all killed. Nevertheless it will appear to the lay mind, we think, that the final outcome of the court of inquiry, and of two courts-martial in which three dozen witnesses were examined, is absurdly out of proportion to the fearful explosion that was under investigation. "A mountain was in labor, sending forth dreadful groans, and there was in the region the highest expectation. After all, it brought forth a mouse."

Inspectors' Reports for September, October, November, and December, 1905.

NATURE OF DEFECTS.	SEPTEMBER.		OCTOBER.		NOVEMBER.		DECEMBER.	
	Total defects.	Dangerous.	Total defects.	Dangerous.	Total defects.	Dangerous.	Total defects.	Dangerous.
	Cases of deposit of sediment,	1,431	108	1,326	79	1,380	81	1,383
Cases of incrustation and scale,	3,105	85	3,046	89	2,980	79	3,056	80
Cases of internal grooving,	212	25	230	11	126	11	226	14
Cases of internal corrosion,	1,094	54	996	27	813	32	921	28
Cases of external corrosion,	875	68	815	43	670	41	714	47
Defective braces and stays,	117	42	158	28	200	33	158	39
Settings defective,	443	41	543	54	406	42	389	50
Furnaces out of shape,	614	38	549	15	523	25	577	17
Fractured plates,	279	42	300	64	306	46	235	37
Burned plates,	593	42	410	29	397	59	379	28
Laminated plates,	88	9	68	9	70	7	98	5
Cases of defective riveting,	274	65	319	43	323	87	318	92
Defective heads,	114	16	171	16	120	8	97	9
Leakage around tubes,	859	76	934	93	957	72	1,164	181
Cases of defective tubes,	464	83	439	101	470	164	494	215
Tubes too light,	143	25	103	20	99	18	192	92
Leakage at joints,	492	36	512	39	497	23	425	32
Water-gauges defective,	391	58	279	65	262	55	243	37
Blow-offs defective,	352	92	352	103	358	104	283	95
Cases of deficiency of water,	35	9	35	6	35	12	34	12
Safety-valves overloaded,	80	19	97	26	80	15	70	24
Safety-valves defective,	122	30	128	39	132	26	125	38
Pressure gauges defective,	653	39	575	31	591	35	630	51
Without pressure gauges,	12	12	22	22	31	31	9	9
Unclassified defects,	2	0	1	1	0	0	0	0
Totals,	12,714	1,114	12,413	1,053	11,866	1,097	12,220	1,328

Inspectors' Reports.

On page 28 we present a general summary, by defects, of the work done by the inspectors of the Hartford Steam Boiler Inspection and Insurance Company, during the months of September, October, November, and December, 1905. The number of visits of inspection made, the total number of boilers examined, the total number inspected internally, the number tested by hydrostatic pressure, and the number of boilers condemned, during these months, may be seen in the table entitled "Summary by Months," on page 30 of this issue.

Summary of Inspectors' Reports for the Year 1905.

During the year 1905 our inspectors made 159,561 visits of inspection, examined 291,041 boilers, inspected 116,762 boilers both internally and externally, subjected 13,266 to hydrostatic pressure, and found 753 unsafe for further use. The whole number of defects reported was 155,024, of which 14,209 were considered dangerous. A summary of the work by defects is presented herewith.

SUMMARY, BY DEFECTS, FOR THE YEAR 1905.

Nature of Defects.	Whole Number.	Dangerous.
Cases of deposit of sediment,	17,757	1,192
Cases of incrustation and scale,	38,965	1,098
Cases of internal grooving,	2,783	235
Cases of internal corrosion,	13,109	556
Cases of external corrosion,	10,155	724
Defective braces and stays,	2,045	487
Settings defective,	5,887	588
Furnaces out of shape,	7,422	279
Fractured plates,	3,559	559
Burned plates,	5,181	520
Laminated plates,	958	93
Cases of defective riveting,	3,658	686
Defective heads,	1,729	199
Leakage around tubes,	11,768	1,381
Cases of defective tubes,	4,503	1,341
Tubes too light,	891	258
Leakage at joints,	6,088	401
Water-gauges defective,	3,283	792
Blow-offs defective,	4,607	1,185
Cases of deficiency of water,	341	108
Safety-valves overloaded,	1,229	364
Safety-valves defective,	1,463	390
Pressure gauges defective,	7,413	508
Without pressure gauges,	220	220
Unclassified defects,	10	5
Total,	155,024	14,209

The following table is also of interest. It shows that our inspectors have made over two million visits of inspection, and that they have made nearly four and a half million inspections, of which nearly a million and three quar-

ters were completed internal inspections. The hydrostatic test has been applied in nearly a quarter of a million cases. Of defects, more than three million have been discovered and pointed out to the owners of the boilers; and more than three hundred thousand of these defects were, in our opinion, dangerous. Nearly eighteen thousand boilers have been condemned by us as unfit for further service, good and sufficient reasons for the condemnation being given to the assured in each instance.

GRAND TOTAL OF THE INSPECTORS' WORK SINCE THE COMPANY BEGAN BUSINESS,
TO JANUARY 1, 1906.

Visits of inspection made,	2,288,530
Whole number of boilers inspected,	4,452,437
Complete internal inspections,	1,732,428
Boilers tested by hydrostatic pressure,	224,288
Total number of defects discovered,	3,016,605
Number of dangerous defects discovered,	310,759
Total number of boilers condemned,	17,738

SUMMARY BY MONTHS FOR 1905.

MONTH.	Visits of inspection.	Number of boilers examined.	No. inspected internally and externally.	No. tested hydrostatically.	No. condemned.	No. of defects found.	No. of dangerous defects found.
January,	14,333	26,995	8,191	725	51	11,436	1,086
February,	12,192	23,370	7,026	654	39	9,727	850
March,	14,145	25,513	8,675	957	73	12,607	1,314
April,	12,721	23,280	10,567	1,006	93	14,361	1,358
May,	12,923	24,239	10,526	1,115	87	14,358	1,180
June,	13,089	22,611	11,148	1,340	75	14,045	961
July,	13,020	23,612	13,180	1,344	95	16,222	1,602
August,	12,090	21,176	9,994	1,393	56	13,055	1,266
September,	13,120	23,117	10,047	1,292	45	12,714	1,114
October,	14,097	25,534	9,815	1,376	45	12,413	1,053
November,	14,091	26,274	8,676	1,034	50	11,866	1,097
December,	13,740	25,320	8,917	1,030	44	12,220	1,328
Totals,	159,561	291,041	116,762	13,266	753	155,024	14,209

COMPARISON OF INSPECTORS' WORK DURING THE YEARS 1904 AND 1905.

	1904.	1905.
Visits of inspection made,	159,553	159,561
Whole number of boilers inspected,	299,436	291,041
Complete internal inspections,	117,366	116,762
Boilers tested by hydrostatic pressure,	12,971	13,266
Total number of defects discovered,	154,282	155,024
“ “ of dangerous defects,	13,390	14,209
“ “ of boilers condemned,	883	753

Hartford Steam Boiler Inspection and Insurance Company.

ABSTRACT OF STATEMENT, JANUARY 1, 1906.

Capital Stock, \$500,000.00.

ASSETS.

	Par Value.	Market Value.
Cash in office and in Bank,		\$137,832.23
Premiums in course of collection (since Oct. 1, 1905),		201,827.69
Interest accrued on Mortgage Loans,		24,082.58
Loaned on Bond and Mortgage,		952,645.00
Real Estate,		14,690.00
State of Massachusetts Bonds,	\$100,000.00	96,000.00
County, City, and Town Bonds,	368,500.00	383,880.00
Board of Education and School District Bonds,	46,500.00	48,300.00
Drainage and Irrigation Bonds,	5,000.00	5,000.00
Railroad Bonds,	1,231,000.00	1,365,000.00
Street Railway Bonds,	60,000.00	59,150.00
Miscellaneous Bonds,	65,500.00	67,305.00
National Bank Stocks,	41,800.00	57,600.00
Railroad Stocks,	177,800.00	240,909.00
Miscellaneous Stocks,	35,500.00	33,925.00
	<hr/>	
	\$2,131,600.00	

Total Assets, \$3,688,146.50

LIABILITIES.

Re-insurance Reserve,		\$1,851,706.33
Losses unadjusted,		34,614.94
Commissions and brokerage,		40,365.54
Surplus,	\$1,261,459.69	
Capital Stock,	500,000.00	
	<hr/>	

Surplus as regards Policy-holders, \$1,761,459.69 1,761,459.69

Total Liabilities, \$3,688,146.50

On December 31, 1905, the HARTFORD STEAM BOILER INSPECTION AND INSURANCE COMPANY had 92,038 steam boilers under insurance.

L. B. BRAINERD, Pres. and Treas. FRANCIS B. ALLEN, Vice-President.

J. B. PIERCE, Secretary. L. F. MIDDLEBROOK, Asst. Sec'y.

C. S. BLAKE, Supervising General Agent.

E. J. MURPHY, M. E., Consulting Engineer.

BOARD OF DIRECTORS.

FRANK W. CHENEY, Treas. Cheney Brothers Silk Manufacturing Co.	ATWOOD COLLINS, Prest. Security Co., Hartford, Conn.
CHARLES M. BEACH, of Beach & Co.	LUCIUS F. ROBINSON, Attorney, Hartford, Conn.
GEORGE BURNHAM, Baldwin Locomotive Wks., Philadelphia.	JOHN O. ENDERS, U. S. Bank, Hartford, Conn.
Hon. NATHANIEL SHIPMAN, Judge United States Circuit Court, retired.	LYMAN B. BRAINERD, President and Treasurer Steam Boiler Inspection and Insurance Co.
C. C. KIMBALL, President Smyth Manufacturing Co., Hartford, Conn.	MORGAN B. BRAINARD, Asst. Treasurer Etna Life Insurance Co.
PHILIP CORBIN, P. & F. Corbin, New Britain, Ct.	F. B. ALLEN, Vice-Prest. Hartford Steam Boiler Inspection and Insurance Co.
GEORGE A. FAIRFIELD, Pres. Hartford Machine Screw Co.	CHARLES P. COOLEY, Treas. The Fidelity Company, Hartford, Conn.
J. B. PIERCE, Secretary Hartford Steam Boiler Inspection and Insurance Co.	

Incorporated
1866.



Charter Per-
petual.

The Hartford Steam Boiler Inspection and Insurance Company

ISSUES POLICIES OF INSURANCE COVERING

ALL LOSS OF PROPERTY

AS WELL AS DAMAGE RESULTING FROM

LOSS OF LIFE AND PERSONAL INJURIES DUE TO STEAM BOILER EXPLOSIONS.

*Full information concerning the Company's Operations can be obtained at
any of its Agencies.*

Department.	Representatives.	Offices.
NORTHEASTERN, .	C. E. ROBERTS, Manager, F. S. ALLEN, Chief Inspector,	{ Boston, Mass., 101 Milk St. Providence, R. I., 29 Weybosset St. New York City, N. Y., 160 Broadway.
NEW YORK, . . .	C. C. GARDINER, JR., Manager, R. K. McMURRAY, Chief Inspector,	Philadelphia, Pa., 432 Walnut St.
PENNSYLVANIA, .	CORBIN & GOODRICH, Gen. Agents, WM. J. FARRAN, Chief Inspector,	{ Baltimore, Md., 13-14-15 Abell Bldg. Washington, D. C., 511 Eleventh St., N. W.
MARYLAND, . . .	LAWFORD & McKIM, Gen. Agents, R. E. MUNRO, Chief Inspector,	Charleston, S. C., 44 Broad St.
SOUTHEASTERN, .	W. S. HASTIE & SON, Gen. Agts., W. M. FRANCIS, Chief Inspector,	Birmingham, Ala., 214-216 W. 20th St.
SOUTHERN, . . .	LOUIS V. CLARK & Co., Gen. Agents, H. E. STRINGFELLOW, Chief Inspector,	New Orleans, La., 818 Gravier St.
GULF,	PETER F. PESCU, General Agent, R. T. BURWELL, Chief Inspector,	Hartford, Conn., 650 Main St.
HOME,	E. H. WARNER, General Agent, H. C. LONG, Special Agent, F. H. WILLIAMS, Special Agent, F. S. ALLEN, Chief Inspector,	Bridgeport, Conn., 1 Sanford Building.
SOUTHERN CONN.,	W. G. LINERBURGH & SON, Gen. Agts., J. H. RANDALL, Chief Inspector,	Pittsburg, Pa., 401 Wood Street.
PITTSBURG, . . .	JAMES W. ARROTT, LTD., Gen. Agt., BENJAMIN FORD, Chief Inspector,	Cleveland, Ohio, 337 W Superior Ave., N. W
NORTHERN OHIO,	C. A. BURWELL, General Agent, H. A. BAUMHART, Chief Inspector,	Chicago, Ill., 169 Jackson St.
NORTHWESTERN,	H. M. LEMON, Manager, JAMES L. FOORD, Chief Inspector,	St. Louis, Mo., 319 North Fourth St.
SOUTHWESTERN,	VICTOR HUGO, Manager, VICTOR HUGO, Chief Inspector,	Denver, Col., 210-215 Ta bor Opera House Bldg
WESTERN,	THOS. F. DALY, General Agent, T. E. SHEARS, Chief Inspector,	San Francisco, Cal., 306 Sansome St.
PACIFIC COAST, .	MANN & WILSON, General Agents, J. B. WARNER, Chief Inspector,	

The Locomotive

PUBLISHED BY THE HARTFORD STEAM BOILER INSPECTION AND INSURANCE COMPANY.

Vol. XXVI.

HARTFORD, CONN., APRIL, 1906.

No. 2.

Explosion of a Heating Boiler.

The illustrations presented herewith show a portion of the destruction recently wrought by the explosion of a cast-iron steam heating boiler, in a private residence at St. Paul, Minn. The explosion occurred at about 8 o'clock A.M., five persons being in the house at the time. Mr. W— (who occupied the building) was in the kitchen, his wife was in the sitting-room adjoining, and three children were in their bedrooms on the second floor. The boiler gave



FIG. 1. — INTERIOR OF THE WRECKED SITTING ROOM.

way without the slightest warning, and fragments of iron and other wreckage were projected through the house in all directions. By great good fortune, nobody was seriously injured; though it is hard to understand this fact, in view of the nature and violence of the explosion.

The entire building was shaken and damaged, windows and chimneys were demolished, doors were hurled from their hinges, and the flooring of three rooms on the first floor was shattered. The chair in which Mrs. W— was sitting was

thrown upward, against the ceiling, and its occupant fell back through a jagged opening in the floor into the basement. Stones from the foundation of the building and débris of various kinds were thrown several blocks, and windows were broken in neighboring dwellings.

Our engravings show the room in which Mrs. W— was sitting, Fig. 1 being taken within the apartment, and Fig. 2 from the dining-room adjoining. Mrs. W— was in the corner of the room, near the window seen on the left



FIG. 2.— SITTING ROOM AS SEEN FROM DINING ROOM.

of Fig. 2. The light below this is from a window in the basement; and the opening in the floor which renders this basement window visible is the one through which Mrs. W— fell. If the explosion had occurred a few minutes later, the entire family would have been in the wrecked sitting-room, and doubtless there would have been one or more fatalities to record.

The property loss caused by this explosion was estimated at \$5,000.

THE Hartford Steam Boiler Inspection and Insurance Company publishes an excellent little book on the metric system. Single copies are \$1.25 each, postage prepaid. A copy may be had on bond paper for \$1.50.

Concerning Staybolts.

Experience has shown that staybolts are apt to be troublesome elements in boiler construction, unless careful attention is given both to their general design, and to the material of which they are composed. The stress that is thrown upon a staybolt is of a compound type, part of the load being tolerably constant, while another part may vary to a considerable extent, while the boiler is in continuous service at a pressure that is uniform, or nearly so.

Let us consider, for example, the water-leg of a locomotive boiler. Each staybolt in such a water-leg is manifestly subject to a direct longitudinal tensile stress, whose magnitude depends upon the pressure of the steam within the boiler, and also upon the way in which the staybolts are spaced in the sheets. This part of the load will not be subject to any sensible variation, so long as the pressure remains constant. In addition to this direct longitudinal tension, however, the bolt is subject to bending stresses that arise from slight relative motions (perpendicular to the length of the bolt) of the two sheets to which

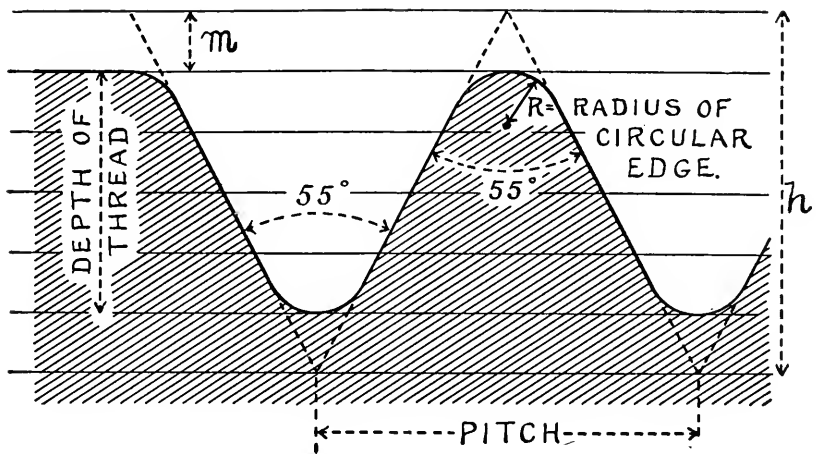

FIG. I. — THE WHITWORTH THREAD.

the bolt is secured. These relative motions of the sheets are due in part to the fact that the inner and outer sheets are ordinarily at somewhat different temperatures, so that there is a differential expansion or contraction, every time the boiler is heated up or cooled. In railway service, the vibratory motions due to irregularities in the track doubtless contribute materially, also, to the action; and even in stationary boilers of the locomotive type there will be slight motions due to variations of temperature from opening the furnace door, or to feeding the boiler with water not at the exact temperature corresponding to the pressure carried, or to any one of a number of different causes.

The way in which the bending stresses that are thus thrown upon the bolt act upon it was illustrated in the issue of THE LOCOMOTIVE for December, 1897. The stresses that are so produced within the bolts may be of considerable intensity. This is proved, of course, by the very fact of the failure of the bolts, even when they have a large factor of safety with respect to the direct tension due to the steam load; but it is perhaps more impressive to compute the actual

stress thrown upon a given staybolt, when the bolt is subjected to definite conditions that might conceivably be attained in practice. Mr. H. V. Wille, M. E., of the Baldwin Locomotive Works, has made some computations of this kind, and we quote his results, as given in his paper entitled "Staybolt Iron and Machine for Making Vibratory Tests," in the fourth volume (1904) of the *Proceedings of the American Society for Testing Materials*, page 316.

"Assuming as a basis in our calculation," he says, "a staybolt of one inch diameter and a deflection [*i. e.*, a relative motion of the two sheets perpendicularly to the bolt.] of 3-100 inch, and a distance between sheets of six inches, we find that the bolt is strained to a fiber stress of 35,000 pounds per square inch. If the diameter is reduced to $\frac{3}{4}$ inch, the staybolt is strained to but 26,250 pounds; and by decreasing the distance between the two sheets to 5 inches, the bolts are strained to 50,400 for the one inch bolt, and 37,700 for the $\frac{3}{4}$ inch. These results show very clearly the cause of staybolt breakage, and what should be done in order to reduce the trouble to a minimum; namely, make the water space as wide as possible, and use a small bolt, with a closer space if necessary."

The importance of the action here indicated being recognized, it is evident that in selecting material for the manufacture of staybolts we should pay due

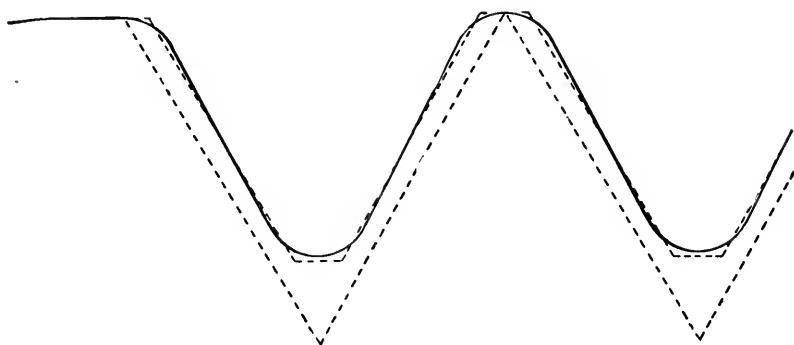

FIG. 2.—THE WHITWORTH, SHARP V, AND SELLERS THREADS, COMPARED.

regard to the capability of such material to withstand alternate bending stresses of considerable magnitude; and this amounts to admitting that staybolt material should be tested, not only to destruction by direct tension, but also to destruction by alternating bending stresses similar to those that it will have to withstand in practice. Machines for executing tests of this latter character have been known and used for many years; the first work of the sort having been done by Wöhler, in 1857. A great deal has been learned about the effects of intermittent and alternating strains upon materials so tested, and yet the results that have been attained have not been satisfactory in all respects. We cannot undertake to give a full list of papers that have dealt with this subject, but we desire to call attention particularly to three, which are not only highly interesting and instructive, but also easily accessible. The first of these is entitled "Strains in Locomotive Boilers." It was written by L. S. Randolph, and is printed in the ninth volume of the *Transactions of the American Society of Mechanical Engineers*, page 534. Mr. Randolph describes a number of experiments in which staybolts were tested to destruction by alternating bending

stresses, and he considers that the probable length of life that his experiments indicate for a staybolt corresponds very well with that observed in practice. The second of the three papers referred to above is by Mr. Francis J. Cole, is entitled "Bending Tests of Locomotive Staybolts," and is given on page 662 of the nineteenth volume of the *Transactions* of the same society. The results of many tests are given, and the paper is fully illustrated. The third of the papers to which special reference has been made is the one by Mr. Wille, from which a quotation is given above. Mr. Wille describes the improved Olsen machine for "vibratory" testing, which he hopes will yield results more consistent and satisfactory than have yet been obtained from tests of this character. If experience proves this hope to be justified, we shall be able in the near future to specify staybolt material in a more intelligent and definite manner than has been possible in the past.

At the present time it is usual to specify the quality of staybolt iron by giving the required tensile strength, and the elongation that must be realized before fracture, in a specimen of stated length. Mr. Wille gives the requirements of fifteen American railroad systems with respect to the elongation and ultimate tensile strength of staybolt iron (see THE LOCOMOTIVE for July, 1904, page 68); and while these requirements vary somewhat among themselves, the differences are not great, and it may be said in a general way that the railroads of the United States require that staybolt iron shall have an ultimate tensile strength of about 48,000 pounds per square inch, and an elongation of from 25 to 28 per cent., in a length of eight inches. The resistance of the material to fracture from repeated bending, owing to the relative motion of the sheets, is commonly supposed to be provided for by the adoption of a suitable factor of safety; this factor being based merely upon the ultimate tensile strength of the bolt. Manifestly this factor must be larger than would suffice for a boiler sheet, or for other structural parts in which the stresses are of a steady type.

Rankine (*Steam Engine*, page 459,) quotes, with approval, Bourne's opinion that staybolts should not be exposed to a tensile stress greater than 3,000 pounds per square inch. With iron of 48,000 pounds tensile strength, this corresponds to a factor of safety of 16. For staybolts of ordinary size, this estimate of the proper factor is certainly excessive, and few if any modern engineers would agree to it. For staybolts of very small size it might be reasonable, however, since loss of material from corrosion would then be of far more importance than in larger bolts. Thurston (*Steam Boilers*, page 147,) gives 8 as the minimum factor of safety for staybolts, and he favors 10 or more, to allow for the reduction of strength from corrosion. Meyer (*Modern Locomotive Construction*, page 463,) states that the tensile stress on the smallest section of the staybolt must not exceed 6,000 pounds per square inch; or, in other words, he gives 8 as the minimum factor of safety, for the kind of iron commonly used by our railroads. Lloyd's allows 8,000 pounds per square inch of net section on staybolts having an effective diameter not exceeding $1\frac{1}{2}$ inches, and 9,000 on those having an effective diameter greater than $1\frac{1}{2}$ inches. With iron of 48,000 pounds tensile strength, this would correspond to a minimum factor of safety of 6, for staybolts less than $1\frac{1}{2}$ inches in effective diameter. The National Boiler & General Insurance Company, Ltd., of Manchester, Eng., allows 7,000 pounds per square inch of net section on iron staybolts secured to iron plates, and 8,000 pounds on steel staybolts secured to steel plates. No figures are given for iron staybolts in steel plates; but perhaps we might assume that something over

7,000 pounds would be allowed in that case. The corresponding factor of safety, for the grade of staybolt iron assumed above, would then be about 6.5. Unwin (*Elements of Machine Design*, edition of 1898, volume 1, page 136,) gives 5,000 to 6,000 pounds per square inch of net section as the permissible tensile stress on iron staybolts. This, for iron of 48,000 pounds tensile strength, corresponds to a factor of safety of from 8 to 9.6. Finally, the U. S. Board of Supervising Inspectors (*General Rules and Regulations*, 1905, page 19,) requires that the tensile stress on staybolts shall not exceed 6,000 pounds per square inch of least sectional area; this corresponding, in the case of the iron specified above, to a factor of safety of 8.

Omitting the estimate of Rankine, which is certainly far outside of modern practice, we see that the various authorities here cited agree that the factor of safety should not be less than from 6 to 8. We hold that a factor of 8 should be secured wherever this is possible; but in view of the large experience of Lloyd's and of the National Boiler & General Insurance Co., Ltd., we admit, at the same time, that there is good authority for the use of a somewhat smaller factor. In general, we are of the opinion that with staybolt iron of the kind ordinarily used by our railroads, it is desirable that the maximum tensile load upon the staybolt should not greatly exceed 6,000 pounds per square inch of smallest section; though in special cases it may be permissible to admit a load of 7,000 or even 8,000 pounds. The phrase "special cases" is here understood to refer to those instances in which the workmanship and material of the boiler are known to be of unusual excellence. For example, it would be absurd to make one and the same hard and fast rule, and apply it equally to ordinary staybolt iron about which no more is known than its tensile strength and elongation, and to iron that has been piled as recommended by Mr. Wille, and tested by modern "vibratory" methods.

Staybolts are supposed to be threaded and screwed into both sheets and then headed over, cold, at both ends. The thread almost universally adopted is the sharp V-thread, having an angle of 60 degrees. It is desirable to have three or four complete threads within each sheet, and as the standard threads used on common bolts of the same sizes would not give this number, it is customary to use twelve threads to the inch on every size of staybolt. Ten threads per inch are also used to some extent, and staybolts will likewise be found that have $11\frac{1}{2}$ threads per inch; this being the standard for pipes of from one to two inches nominal diameter, inclusive. Nearly all staybolts, however, have twelve threads to the inch, and the thread is almost invariably of the sharp V form.

The advantage claimed for the sharp V-thread is, that staybolts provided with it can be made tight more readily than they can if fitted with threads of other forms.

The tensile strength of a staybolt, it must be clearly understood, is the tensile strength of the smallest cross-section of the bolt. If the staybolt is solid, and not turned down in the middle nor upset at the ends, the smallest cross-section is the circle whose diameter is equal to the diameter of the bolt as measured *at the bottom of the thread*. If the bolt is made hollow, or is drilled at the ends, then the area of cross-section of the hole must be deducted from the area of cross-section of the solid bolt at the bottom of the thread, in order to find the least sectional area, upon which to base the calculated strength of the bolt. If the bolt is turned down in the middle, or (which amounts to the same thing)

Table 1.—Staybolt Proportions.—Sharp V-Threads.

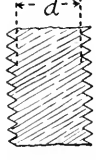
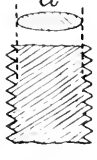
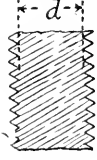
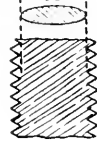
Outside Diameter of Bolt. (In.)	TWELVE THREADS PER INCH.		TEN THREADS PER INCH.	
	Diameter at Bottom of Thread. (In.)	Area at Bottom of Thread. (Sq. In.)	Diameter at Bottom of Thread. (In.)	Area at Bottom of Thread (Sq. In.)
				
5/8	0.4807	0.1815	0.4518	0.1603
11/16	0.5432	0.2317	0.5143	0.2077
3/4	0.6057	0.2881	0.5768	0.2613
13/16	0.6682	0.3506	0.6393	0.3210
7/8	0.7307	0.4193	0.7018	0.3868
15/16	0.7932	0.4941	0.7643	0.4588
1	0.8557	0.5750	0.8268	0.5369
1 1/16	0.9182	0.6621	0.8893	0.6211
1 1/8	0.9807	0.7553	0.9518	0.7115
1 3/16	1.0432	0.8547	1.0143	0.8080
1 1/4	1.1057	0.9601	1.0768	0.9107
1 5/16	1.1682	1.0718	1.1393	1.0194
1 3/8	1.2307	1.1895	1.2018	1.1344
1 7/16	1.2932	1.3134	1.2643	1.2554
1 1/2	1.3557	1.4434	1.3268	1.3826
1 5/8	1.4807	1.7219	1.4518	1.6554
1 3/4	1.6057	2.0249	1.5768	1.9527
1 7/8	1.7307	2.3524	1.7018	2.2746
2	1.8557	2.7045	1.8268	2.6210

For sharp V-threads, the depth of the thread is 0.07217 in. for 12 threads per inch, and 0.08660 in. for 10 threads per inch.

is upset at the ends, then it may happen that the least area of cross-section is in the central portion of the bolt. All these circumstances must be considered in computing the tensile strength of a staybolt. The tables that are given in connection with this article apply only to solid bolts; the least sectional area of the bolt, in every case, being assumed to be equal to the area of the circle whose diameter is the same as that of the bolt, measured at the bottom of the thread.

The external diameter of a staybolt being given, and the kind of thread upon it being also given, together with the number of threads per inch, we may com-

pute the diameter of the bolt at the bottom of the thread, provided we know that the thread is standard of its kind: and in this way we may arrive at the resistance that the staybolt would offer to rupture by direct tension in the direction of its length.

In Table 1 we give various data relating to solid staybolts having sharp 60° V-threads, when threaded twelve threads and ten threads to the inch, respectively. The "outside diameter" of a staybolt is understood to mean, in every case, the diameter as measured *over the outside of the actual thread*. In some forms of boilers a portion of the bolt may remain of full size, and yet unthreaded; but in such cases the diameter must not be measured over the unthreaded portion, because the die with which the thread was cut may not have been set correctly, and hence the outside diameter of the actual thread may not correspond exactly with the outside diameter of the original stock.

The tables include many sizes of staybolts that are not supposed to be met with in practice, at least to any great extent. Thus we have made the sizes progress by sixteenths, although most of the sixteenths herein represented are not supposed to be used. This is because we find, in our experience, that a staybolt that is intended to be of a certain size not infrequently departs by nearly or quite one-sixteenth from the nominal size that it purports to be; and hence it is well to have the tables run by sixteenths, except in the largest sizes.

In the practical work of designing and inspecting, it is convenient to have the actual tensile strengths of staybolts tabulated, so that it will not be necessary to compute them in each special case. For this reason we present, in Tables 2 and 3, the calculated strengths of the net sections (at the bottom of the thread) of solid staybolts of a great variety of sizes, and for materials of a wide range of tensile strengths. Table 2 is for V-threads, twelve threads to the inch, and Table 3 is for V-threads, ten threads to the inch.

Although practice has almost universally favored the employment of the sharp V-thread upon staybolts, we are of the opinion that the main advantage (and perhaps the only real advantage) of a thread of this sort is that it can be made tight in the sheets, and kept tight, without any great difficulty. On the other hand, the use of the V-thread violates one of the fundamental principles of machine design;—the principle, namely, of avoiding all re-entrant angles, and of filleting every place where such angles tend to occur. In the discussion following the reading of Mr. Randolph's paper, cited above, Mr. J. T. Hawkins remarked upon this point as follows: "I think the case of staybolts is an instance warning the engineer to avoid, in every possible way, anything like a re-entering angle in members of structures which receive strains, such as a thread in these staybolts where they are to be subjected to any such action as is characterized as 'wiggling' in the paper . . . We have here a staybolt which is threaded throughout its entire length, and fracturing invariably, as shown, either near or within the plate; and it appears to me that this is a case where the re-entering angles of the threads give every facility for initiating a crack or cracks in the bolts from the continued vibration or oscillation produced by the difference of expansion of the two sheets."

The considerations here stated must have occurred many times to engineers and designers, and yet no general movement has been made to discard the V-thread and substitute for it a form that shall not be open to the same objection. The Whitworth thread is receiving considerable attention at the present time, however, for use upon staybolts, and it is regarded with favor by certain

Table 2.—Solid Staybolts.—Sharp V-Thread.—Twelve Threads per Inch.

This table gives, directly, the ultimate tensile strength (in pounds) of the net sectional area, as measured at the bottom of the thread. The necessary allowance for the depth of the thread has already been made.

Outside diameter (Inches).	TENSILE STRENGTH OF MATERIAL OF STAYBOLT, IN POUNDS PER SQUARE INCH.												
	40,000	42,000	44,000	45,000	46,000	48,000	50,000	52,000	54,000	55,000	56,000	58,000	60,000
5/8	7,260	7,620	7,980	8,170	8,350	8,710	9,070	9,440	9,800	9,980	10,160	10,520	10,890
1 1/16	9,270	9,730	10,200	10,430	10,660	11,120	11,590	12,050	12,510	12,740	12,980	13,440	13,900
3/4	11,520	12,100	12,680	12,960	13,250	13,830	14,410	14,980	15,560	15,850	16,130	16,710	17,290
13/16	14,030	14,730	15,430	15,780	16,130	16,830	17,530	18,230	18,930	19,280	19,640	20,340	21,040
7/8	16,770	17,610	18,450	18,870	19,290	20,130	20,960	21,800	22,640	23,060	23,480	24,320	25,160
15/16	19,760	20,750	21,740	22,230	22,730	23,720	24,700	25,690	26,680	27,180	27,670	28,660	29,650
1	23,000	24,150	25,300	25,880	26,450	27,600	28,750	29,900	31,050	31,630	32,200	33,350	34,500
1 1/16	26,480	27,810	29,130	29,790	30,460	31,780	33,110	34,430	35,750	36,420	37,080	38,400	39,730
1 1/8	30,210	31,720	33,230	33,990	34,740	36,260	37,770	39,280	40,790	41,540	42,300	43,810	45,320
1 3/16	34,190	35,900	37,610	38,450	39,310	41,020	42,730	44,440	46,150	47,010	47,860	49,570	51,280
1 1/4	38,410	40,330	42,250	43,210	44,170	46,090	48,010	49,930	51,850	52,810	53,770	55,690	57,610
1 5/16	42,870	45,010	47,160	48,230	49,300	51,440	53,590	55,730	57,870	58,950	60,020	62,160	64,310
1 3/8	47,580	49,960	52,340	53,530	54,720	57,100	59,480	61,850	64,230	65,420	66,610	68,990	71,370
1 7/16	52,540	55,160	57,790	59,100	60,420	63,040	65,670	68,300	70,920	72,240	73,550	76,180	78,800
1 1/2	57,740	60,620	63,510	64,950	66,400	69,280	72,170	75,060	77,940	79,390	80,830	83,720	86,610
1 5/8	68,880	72,320	75,760	77,480	79,210	82,650	86,090	89,540	92,980	94,790	96,420	99,870	103,310
1 3/4	80,990	85,040	89,090	91,120	93,140	97,190	101,240	105,290	109,340	111,370	113,390	117,440	121,490
1 7/8	94,100	98,800	103,510	105,860	108,210	112,920	117,620	122,330	127,030	129,380	131,740	136,440	141,140
2	108,180	113,590	119,000	121,700	124,410	129,820	135,230	140,630	146,040	148,750	151,450	156,860	162,270

Table 3.—Solid Staybolts.—Sharp V-Thread.—Ten Threads per Inch.

This table gives, directly, the ultimate tensile strength (in pounds) of the net sectional area, as measured at the bottom of the thread. The necessary allowance for the depth of the thread has already been made

Outside diam-eter (Inches).	TENSILE STRENGTH OF MATERIAL OF STAYBOLT, IN POUNDS PER SQUARE INCH.												
	40,000	42,000	44,000	45,000	46,000	48,000	50,000	52,000	54,000	55,000	56,000	58,000	60,000
5/8	6,410	6,730	7,050	7,210	7,370	7,690	8,020	8,330	8,660	8,820	8,980	9,300	9,620
11/16	8,310	8,720	9,140	9,350	9,560	9,970	10,390	10,800	11,210	11,420	11,630	12,050	12,460
3/4	10,450	10,970	11,500	11,760	12,020	12,540	13,060	13,590	14,110	14,370	14,630	15,150	15,680
13/16	12,840	13,490	14,140	14,460	14,770	15,410	16,050	16,700	17,340	17,660	17,970	18,620	19,260
7/8	15,470	16,250	17,020	17,410	17,790	18,570	19,340	20,110	20,890	21,270	21,660	22,440	23,210
15/16	18,350	19,270	20,190	20,650	21,100	22,020	22,940	23,860	24,780	25,240	25,690	26,610	27,530
1	21,450	22,560	23,620	24,160	24,700	25,770	26,840	27,910	28,990	29,520	30,070	31,140	32,210
1 1/16	24,840	26,090	27,330	27,950	28,570	29,810	31,060	32,300	33,540	34,160	34,780	36,020	37,270
1 1/8	28,460	29,880	31,310	32,020	32,730	34,150	35,570	37,000	38,420	39,130	39,840	41,270	42,690
1 3/16	32,320	33,940	35,550	36,360	37,170	38,780	40,400	42,010	43,630	44,440	45,250	46,860	48,480
1 1/4	36,430	38,250	40,070	40,980	41,890	43,710	45,530	47,350	49,180	50,090	51,000	52,820	54,640
1 5/16	40,780	42,820	44,850	45,870	46,890	48,930	50,970	53,010	55,050	56,070	57,090	59,130	61,170
1 3/8	45,370	47,640	49,910	51,050	52,180	54,450	56,720	58,980	61,250	62,390	63,520	65,790	68,060
1 7/16	50,220	52,730	55,240	56,490	57,750	60,260	62,770	65,280	67,790	69,040	70,300	72,810	75,320
1 1/2	55,300	58,070	60,830	62,220	63,600	66,360	69,130	71,890	74,660	76,040	77,430	80,190	82,960
1 5/8	60,220	63,530	66,840	68,490	70,150	73,460	76,770	80,080	83,390	84,770	86,150	89,460	92,770
1 3/4	78,110	82,010	85,920	87,870	89,820	93,730	97,640	101,540	105,440	107,400	109,350	113,260	117,160
1 7/8	90,950	95,530	100,080	102,360	104,630	109,180	113,730	118,280	122,830	125,100	127,380	131,930	136,480
2	104,840	110,080	115,320	117,950	120,570	125,810	131,050	136,290	141,530	144,150	146,780	152,020	157,260

builders of large experience, notably by the Baldwin Locomotive Works, who are now using this thread upon locomotive staybolts. If experience shows that staybolts can be made tight and kept so, when fitted with this thread, we are of the opinion that its adoption will extend to other builders.

The Whitworth thread, named for Sir Joseph Whitworth, its distinguished inventor, is in general use in England, but is seldom met with in the United States. It differs from American threads in two particulars; namely, (1) the angle of the thread is 55° instead of 60° , and (2) the threads are rounded off at the top and bottom, instead of being left sharp, or being made flat, as in the Sellers thread. To aid in forming a clear idea of the general shape and proportions of the Whitworth thread, we may conveniently think of it as consisting, primarily, of a sharp V-thread with an angle of 55° , subsequently modified by rounding off the top and bottom of the V. The shape of the finished thread is shown in Fig. 1, where the shaded portion represents the solid metal. The ideal, or imaginary V, which is indicated in Fig. 1 by the triangular dotted extensions, is modified by rounding off the angles by an amount equal to one-sixth of the total depth of the ideal sharp thread, both at the top and at the bottom; the dimension marked m in Fig. 1 being one-sixth of that marked h . In other words, the depth of the actual Whitworth thread is two-thirds of the depth of the imaginary sharp V from which it is derived. At first thought it might appear as though the radius of the circular edge of the thread were arbitrary; but further reflection will show that this radius is really perfectly definite, since the circle of which it is a part must be tangent to the sides of the thread, and also to the horizontal line which limits the threads at the top or bottom, as the case may be.

Apparently, it was the intention of the designer of this thread to choose the angle of the V so that the depth of the imaginary sharp thread (before the top and bottom are rounded off) should be equal, as nearly as might be consistent with practicable proportions, to the distance from the top of one thread to the top of the next; and we often find the Whitworth standard described as one in which this condition is actually fulfilled. The angle 55° does not make the two precisely equal, however; for it may readily be shown that in order for the stated condition to be rigorously fulfilled, the angle of the V would have to be approximately $53^\circ 07' 48.36''$. This angle would be a difficult one to obtain in practice, and we are of the impression (without looking into the history of the case) that the angle 55° was selected as approximating to this theoretical angle sufficiently well for all ordinary purposes.

In Table 4 we give the proportions of standard Whitworth threads, and of ordinary bolts as provided with these threads; and in Table 5 we give similar data for staybolts provided with Whitworth threads. We also give, in Tables 6 and 7, the ultimate tensile strength of solid staybolts provided with standard Whitworth threads, for twelve and ten threads to the inch, respectively. These last two tables correspond, it will be seen, to Tables 2 and 3, as given for the common sharp V-thread.

The Baldwin Locomotive Works have found, by actual experiment upon vibratory testing machines, that staybolts provided with the Whitworth thread will resist alternating bending stresses better than staybolts having the same tensile strength, but provided with the usual form of sharp V-thread. It is also pointed out that for a given number of threads to the inch, the Whitworth thread is shallower than the common sharp V-thread, so that for staybolts of a

Table 4.—Whitworth Standard Threads for Bolts and Nuts.







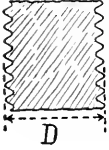

External diameter of bolt. (In.)	Threads per inch.	Depth of thread. (In.)	Diameter at bottom of thread. (In.)	Sectional area of solid bolt. (Sq. In.)	Sectional area at bottom of thread. (Sq. In.)	Radius of circular edge of thread. (In.)
						
1/8	40	0.0160	0.0930	0.0123	0.0068	0.0034
3/16	24	0.0267	0.1341	0.0276	0.0141	0.0057
1/4	20	0.0320	0.1860	0.0491	0.0272	0.0069
5/16	18	0.0356	0.2413	0.0767	0.0457	0.0076
3/8	16	0.0400	0.2950	0.1104	0.0684	0.0086
7/16	14	0.0457	0.3460	0.1503	0.0940	0.0098
1/2	12	0.0534	0.3933	0.1964	0.1215	0.0114
9/16	12	0.0534	0.4558	0.2485	0.1632	0.0114
5/8	11	0.0582	0.5086	0.3068	0.2032	0.0125
11/16	11	0.0582	0.5711	0.3712	0.2562	0.0125
3/4	10	0.0640	0.6219	0.4418	0.3038	0.0137
13/16	10	0.0640	0.6844	0.5185	0.3679	0.0137
7/8	9	0.0711	0.7327	0.6013	0.4216	0.0153
15/16	9	0.0711	0.7952	0.6903	0.4966	0.0153
1	8	0.0800	0.8399	0.7854	0.5541	0.0172
1 1/8	7	0.0915	0.9420	0.9940	0.6969	0.0196
1 1/4	7	0.0915	1.0670	1.2272	0.8941	0.0196
1 3/8	6	0.1067	1.1616	1.485	1.060	0.0229
1 1/2	6	0.1067	1.2866	1.767	1.300	0.0229
1 5/8	5	0.1281	1.3689	2.074	1.472	0.0275
1 3/4	5	0.1281	1.4939	2.405	1.753	0.0275
1 7/8	4-1/2	0.1423	1.5904	2.761	1.987	0.0305
2	4-1/2	0.1423	1.7154	3.142	2.311	0.0305
2 1/8	4-1/2	0.1423	1.8404	3.547	2.660	0.0305
2 1/4	4	0.1601	1.9298	3.976	2.925	0.0343
2 3/8	4	0.1601	2.0548	4.430	3.316	0.0343
2 1/2	4	0.1601	2.1798	4.909	3.732	0.0343
2 5/8	4	0.1601	2.3048	5.412	4.172	0.0343
2 3/4	3-1/2	0.1830	2.3841	5.940	4.644	0.0392
2 7/8	3-1/2	0.1830	2.5091	6.492	4.945	0.0392
3	3-1/2	0.1830	2.6341	7.069	5.449	0.0392

Table 5.—Staybolt Proportions.—Whitworth Thread.

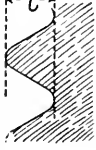
Outside Diameter of bolt. (In.)	TWELVE THREADS PER INCH.		TEN THREADS PER INCH.	
	Diameter at Bottom of Thread. (In.)	Area at Bottom of Thread (Sq. In.)	Diameter at Bottom of Thread (In.)	Area at Bottom of Thread. (Sq. In.)
				
5/8	0.5183	0.2110	0.4969	0.1939
11/16	0.5808	0.2649	0.5594	0.2458
3/4	0.6433	0.3250	0.6219	0.3038
13/16	0.7058	0.3912	0.6844	0.3679
7/8	0.7683	0.4636	0.7469	0.4381
15/16	0.8308	0.5421	0.8094	0.5145
1	0.8933	0.6267	0.8719	0.5971
1 1/16	0.9558	0.7175	0.9344	0.6858
1 1/8	1.0183	0.8144	0.9969	0.7805
1 3/16	1.0808	0.9174	1.0594	0.8815
1 1/4	1.1433	1.0256	1.1219	0.9885
1 5/16	1.2058	1.1419	1.1844	1.1018
1 3/8	1.2683	1.2634	1.2469	1.2212
1 7/16	1.3308	1.3909	1.3094	1.3467
1 1/2	1.3933	1.5246	1.3719	1.4783
1 5/8	1.5183	1.8105	1.4969	1.7599
1 3/4	1.6433	2.1208	1.6219	2.0661
1 7/8	1.7683	2.4558	1.7469	2.3969
2	1.8933	2.8153	1.8719	2.7521

The depth of the thread, in the Whitworth standard, is 0.05336 in. for 12 threads per inch, and 0.06403 in. for ten threads per inch.

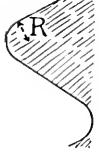
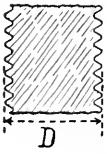
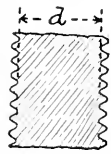
given external diameter and a given number of threads per inch, those provided with the Whitworth thread will have a greater sectional area of solid metal at the bottom of the thread. That this is the case will be seen, not only by a comparison of the tables, but also, and perhaps more clearly, by an examination of Fig. 2, which shows, for one and the same pitch of thread, (1) the ordinary 60° sharp V-thread, (2) the ordinary Sellers thread that is in common use in this country except on pipes and staybolts, and (3) the Whitworth thread. It will be seen from the diagram that the advantage in the matter of depth of thread (and therefore of net section of solid metal at the bottom of the thread) is considerably in favor of the Whitworth standard, as compared with the usual 60°

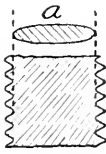
Table 6.—Solid Staybolts.—Whitworth Thread.—Twelve Threads per Inch.

This table gives, directly, the ultimate tensile strength (in pounds) of the net sectional area, as measured at the bottom of the thread. The necessary allowance for the depth of the thread has already been made.

Outside diam-eter. (Inches.)	TENSILE STRENGTH OF MATERIAL OF STAYBOLT, IN POUNDS PER SQUARE INCH.												
	40,000	42,000	44,000	45,000	46,000	48,000	50,000	52,000	54,000	55,000	56,000	58,000	60,000
5/8	8,440	8,860	9,280	9,490	9,700	10,130	10,550	10,970	11,390	11,600	11,810	12,240	12,660
1 1/16	10,600	11,130	11,660	11,920	12,190	12,720	13,250	13,780	14,310	14,570	14,840	15,370	15,890
3/4	13,000	13,650	14,300	14,620	14,950	15,600	16,250	16,900	17,500	17,880	18,200	18,850	19,500
13/16	15,650	16,430	17,210	17,610	18,000	18,780	19,560	20,340	21,130	21,520	21,910	22,690	23,470
7/8	18,540	19,470	20,400	20,860	21,330	22,250	23,180	24,110	25,030	25,490	25,960	26,890	27,820
15/16	21,680	22,770	23,850	24,390	24,940	26,020	27,100	28,190	29,270	29,810	30,360	31,440	32,520
1	25,070	26,320	27,580	28,200	28,830	30,080	31,340	32,590	33,840	34,470	35,100	36,350	37,600
1 1/16	28,700	30,130	31,570	32,290	33,000	34,440	35,870	37,310	38,740	39,460	40,180	41,610	43,050
1 1/8	32,570	34,200	35,830	36,650	37,460	39,090	40,720	42,350	43,980	44,790	45,610	47,230	48,860
1 3/16	36,700	38,530	40,370	41,280	42,200	44,040	45,870	47,710	49,540	50,460	51,380	53,210	55,050
1 1/4	41,060	43,120	45,170	46,200	47,220	49,280	51,330	53,380	55,430	56,460	57,490	59,540	61,590
1 5/16	45,680	47,960	50,240	51,390	52,530	54,810	57,100	59,380	61,660	62,800	63,950	66,230	68,510
1 3/8	50,530	53,060	55,590	56,850	58,120	60,640	63,170	65,690	68,220	69,480	70,750	73,280	75,800
1 7/16	55,640	58,420	61,200	62,590	63,980	66,770	69,550	72,330	75,110	76,500	77,890	80,680	83,460
1 1/2	60,990	64,030	67,080	68,610	70,130	73,180	76,230	79,280	82,330	83,860	85,380	88,430	91,480
1 5/8	72,420	76,040	79,660	81,470	83,280	86,900	90,520	94,140	97,760	99,570	101,390	105,010	108,630
1 3/4	84,830	89,080	93,320	95,440	97,560	101,800	106,040	110,280	114,520	116,650	118,770	123,010	127,250
1 7/8	98,230	103,140	108,050	110,510	112,970	117,880	122,790	127,700	132,610	135,070	137,520	142,440	147,350
2	112,610	118,240	123,870	126,680	129,500	135,130	140,760	146,390	152,020	154,840	157,660	163,290	168,920

Table 7.—Solid Staybolts.—Whitworth Thread.—Ten Threads per Inch.

This table gives, directly, the ultimate tensile strength (in pounds) of the net sectional area, as measured at the bottom of the thread. The necessary allowance for the depth of the thread has already been made.

Outside diam-eter. (Inches.)	TENSILE STRENGTH OF MATERIAL OF STAYBOLT, IN POUNDS PER SQUARE INCH.												
	40,000	42,000	44,000	45,000	46,000	48,000	50,000	52,000	54,000	55,000	56,000	58,000	60,000
5/8	7,760	8,150	8,530	8,730	8,920	9,310	9,700	10,080	10,470	10,670	10,860	11,250	11,640
1 1/16	9,830	10,320	10,810	11,060	11,310	11,800	12,290	12,780	13,270	13,510	13,760	14,260	14,750
3/4	12,150	12,760	13,370	13,670	13,970	14,580	15,190	15,800	16,400	16,710	17,010	17,620	18,230
13/16	14,720	15,450	16,190	16,560	16,920	17,660	18,400	19,130	19,860	20,230	20,600	21,340	22,070
7/8	17,530	18,400	19,280	19,720	20,160	21,030	21,900	22,780	23,660	24,100	24,540	25,410	26,290
15/16	20,580	21,610	22,640	23,100	23,670	24,700	25,730	26,750	27,700	28,300	28,820	29,850	30,870
1	23,880	25,080	26,270	26,870	27,470	28,660	29,850	31,050	32,245	32,840	33,440	34,630	35,830
1 1/16	27,430	28,800	30,170	30,860	31,550	32,920	34,290	35,660	37,030	37,715	38,400	39,770	41,150
1 1/8	31,220	32,780	34,350	35,130	35,910	37,470	39,030	40,590	42,150	42,930	43,710	45,270	46,830
1 3/16	35,260	37,020	38,790	39,670	40,550	42,310	44,080	45,840	47,600	48,490	49,370	51,130	52,890
1 1/4	39,540	41,520	43,500	44,490	45,480	47,450	49,430	51,410	53,380	54,370	55,360	57,340	59,320
1 5/16	44,070	46,280	48,480	49,580	50,680	52,890	55,090	57,290	59,500	60,600	61,700	63,910	66,110
1 3/8	48,850	51,290	53,730	54,950	56,170	58,620	61,060	63,500	65,940	67,160	68,380	70,830	73,270
1 7/16	53,870	56,560	59,250	60,600	61,950	64,640	67,330	70,020	72,720	74,060	75,410	78,110	80,800
1 1/2	59,130	62,090	65,040	66,520	68,000	70,960	73,910	76,870	79,820	81,300	82,780	85,740	88,700
1 5/8	70,400	73,920	77,440	79,200	80,960	84,480	88,000	91,520	95,040	96,800	98,560	102,080	105,600
1 3/4	82,640	86,780	90,910	92,980	95,040	99,170	103,310	107,440	111,570	113,630	115,700	119,830	123,970
1 7/8	95,870	100,670	105,460	107,860	110,250	115,050	119,840	124,630	129,430	131,820	134,220	139,020	143,810
2	110,000	115,590	121,090	123,850	126,600	132,100	137,610	143,110	148,610	151,370	154,120	159,620	165,130

sharp V-thread. The difference between the Whitworth and Sellers threads in this respect is very slight.

It is to be carefully noted that in the tables giving the net strength of stay-bolts, it is the *ultimate* tensile strength that is given. To find the *safe working* tensile stress, we must divide the numbers in the tables by a suitable factor of safety. From what has been said above, it will be plain that we prefer to use 8 as the factor of safety, by which to divide the tabular tensile strengths; but in special cases, such as are discussed above, a factor as small as 6 may be permissible.

Boiler Explosions.

JANUARY, 1906.

- (1.) — On or about January 1, a boiler exploded in a sawmill near Coontown, Casey county, Ky., injuring two men.
- (2.) — A blowoff pipe ruptured, January 2, in the water works and electric light plant at Wapakoneta, Ohio.
- (3.) — The boiler of a logging locomotive exploded, January 3, on the Duluth, Rainy Lake & Winnipeg railroad, near Virginia, Minn. Conductor Benjamin Adams, engineer James Dunn and fireman Harry Fortland were injured, and Mr. Adams died shortly afterwards.
- (4.) — A boiler exploded, January 3, in the Crystal Oil works, at Oil City, Pa. Buildings were considerably damaged, but nobody was injured.
- (5.) — A boiler exploded, on or about January 3, in the steam laundry at Sandpoint, Idaho.
- (6.) — A blowoff pipe failed, January 5, in the Marinette Planing Mill Co.'s plant, at Marinette, Wis.
- (7.) — A boiler explosion occurred, January 8, in the National Tube Co.'s No. 2 mill, at Lorain, Ohio. William Henry was scalded so badly that he died within a few minutes, and three other men were also injured less severely.
- (8.) — A boiler exploded, January 6, at the Taylor Silk Mill, Scranton, Pa. Engineer Patrick Connerton and machinist John Gallagher were fatally injured, and Frederick Andrews, John Moore, Ezelia Evans, Ruth Jones, and three other girls whose names we have not learned, received injuries. The boiler house was destroyed, and a large section of the eastern side of the factory was wrecked.
- (9.) — A heating boiler exploded, January 6, in the residence of George H. Watson, at St. Paul, Minn. Mrs. Watson was slightly injured, and the house was badly damaged, the property loss being estimated at \$5,000.
- (10.) — On January 7 a tube failed in a water-tube boiler at the plant of the Alabama Electric Light & Power Co., Opelika, Ala., doing considerable damage to the boiler. Nobody was hurt.
- (11.) — A cast-iron header ruptured, January 7, in a sectional water-tube boiler at the plant of the Fairbanks Company, Springfield, Ohio.
- (12.) — On January 7 a boiler exploded in Harry C. Leonard's bakery, at Hammondton, N. J. The roof of the building was carried away, and the boiler was thrown to a distance of 125 feet.

(13.) — A slight boiler explosion occurred, January 10, in the plant of the Standard Lamp & Glass Co., Trenton, N. J.

(14.) — On January 12 a boiler exploded during the course of a fire in the plant of the Rock Island Battery Co., Cincinnati, Ohio.

(15.) — A slight explosion occurred, January 13, at the Bessemer City Cotton Mills, Bessemer City, N. C. The damage was confined to the boiler.

(16.) — On January 14 a number of tubes and headers ruptured in the No. 1 mill of the F. H. & C. W. Goodyear Co., Austin, Pa. No one was injured, but the damage to the boiler was quite large.

(17.) — A blowoff pipe failed, January 15, on a boiler in the electric light plant at Atlantic, Iowa.

(18.) — A boiler exploded, January 15, in a sawmill at Squaw Valley, near Emlenton, Butler county, Pa. F. Nolan Grant was struck by a piece of iron and injured so badly that he died four hours later.

(19.) — A boiler belonging to the Knob Haven Oil Co. exploded, on January 15, on the Emily Thompson Oil Lease, in Cross Creek township, near Steubenville, Ohio. A man named Chandler received injuries which were said to be fatal. Fragments of the boiler were thrown to a distance of 300 yards.

(20.) — On January 15 a tube ruptured in a water-tube boiler in the Voigt Milling Co.'s plant, Grand Rapids, Mich.

(21.) — A slight boiler explosion occurred, January 18, in the plant of the Broadway Coal & Ice Co., Memphis, Tenn.

(22.) — On January 18 a tube ruptured in a water-tube boiler in J. H. Holloway's laundry, at Indianapolis, Ind.

(23.) — A boiler exploded, January 19, in William Haug's brewery, at Ferdinand, Ind. John P. Huther was injured seriously and perhaps fatally, and John Haug and George Brosmer were injured less severely. The boiler room was practically wrecked and the boiler itself was thrown to a distance of 300 yards.

(24.) — On January 19 a boiler exploded in the plant of the Annis Grain & Lumber Co., at North Londonderry, N. H. Engineer Justin Sanborn was severely injured. The boiler room was wrecked, and the property loss was \$5,000 or more.

(25.) — A slight boiler explosion occurred, on January 20, in the Peach River Lumber Co.'s plant, at Timber, Tex.

(26.) — On January 20 a firebox sheet failed in a dinkie locomotive belonging to the Peach River Lumber Co., Timber, Tex. There was no other damage. (See also explosion No. 25.)

(27.) — A boiler exploded, January 20, at the Stewart Olive Oil Factory, San Jose, Cal. William Fouch was fatally injured, and one side of the factory was blown out.

(28.) — A boiler exploded, January 21, in the Windermere Hotel, Chicago, Ill. Engineer John Rapkoch was killed, and Mrs. Setta May (one of the guests) was injured. The property loss was estimated at \$25,000. The explosion oc-

curred at 5:33 A. M., which was a very fortunate circumstance, since the boiler was located directly under the dining room, which was torn to pieces. Two hours later there would have been many persons in the room, and the loss of life would doubtless have been great.

(29.) — A blowoff pipe failed, on January 22, in the plant of the United Sash & Door Co., at Wichita, Kans. Engineer M. J. Hollingsworth was injured.

(30.) — The boiler of locomotive No. 204, of the Salt Lake Railroad, exploded, January 22, at San Bernardino, Cal.

(31.) — On January 22, two tubes drew out of a header of a water-tube boiler in the plant of the Berwick Lumber Co., New Orleans, La. The boiler was damaged quite considerably.

(32.) — On January 22 a boiler exploded in John Lagermaier's sawmill, seven miles southeast of Holcombe, near Chippewa Falls, Wis. Eugene Ellenson, Bert Lamb, A. Scott, Edward Vetch, Alexander Foley, and Harry Hicks were killed. Arthur Behnke, Jeremiah Beck, Joseph Johnson, and several other persons whose names we have not learned, were also injured. Behnke's injuries were pronounced fatal, and Beck's recovery was considered doubtful. The property loss was in the neighborhood of \$1,500.

(33.) — A blowoff pipe failed, on January 23, at the office of the United States Express Co., Chicago, Ill.

(34.) — A boiler exploded, January 23, at the Copper Queen smelter, Douglas, Ariz. Fireman J. C. Lebew was instantly killed.

(35.) — On January 24 a boiler exploded in the Palmetto Cotton Mills, at Palmetto, Ga. Fireman William Sexton was instantly killed, and H. T. Harris was injured seriously and perhaps fatally. The power house was destroyed, and the property loss was estimated at \$10,000.

(36.) — A boiler exploded, January 24, on the Mississippi river steamer *Helena*, killing five persons, injuring five others, and wrecking the boat. The explosion occurred sixty-five miles above Natchez, Miss.

(37.) — A blowoff pipe failed, January 23, on the premises of the D. Allen's Sons Rope Co., Broadway, New York.

(38.) — A boiler exploded, January 25, in Andrew Hasenstab's pork packing plant, at Dayton, Ohio. Three sons of the proprietor were slightly injured. The boiler passed up through the roof of the building, and landed about one block away from its original position.

(39.) — On January 25 a water-tube boiler failed at the Great Lakes Engineering Works, Ecorse, Mich.

(40.) — A heating boiler failed, January 25, in Chamberlin & Shaughnessy's gentlemen's furnishing store, Hartford, Conn. The damage was confined to the boiler, and amounted to about \$300.

(41.) — On January 26 a boiler exploded in J. M. Blood's sawmill, at Grayville, Ill. Engineer James Sizemore was instantly killed.

(42.) — A cast-iron header failed, January 27, in a water-tube boiler at the power house of the Philadelphia Rapid Transit Company, Thirteenth and Mount Vernon streets, Philadelphia, Pa.

(43.) — A boiler exploded, January 27, at the Tennessee Coal, Iron & Railroad Co.'s No. 1 mine, near Pratt City, Ala. Samuel Jones, Moses Slaughter, and General Cochran were fatally injured.

(44.) — The boiler of a locomotive belonging to the Canadian Pacific Railroad exploded, January 27, at St. John, N. B. Engineer Albert McHaig was severely scalded and bruised. Stephen Speight, a traveling salesman, also received minor injuries. The locomotive was wrecked.

(45.) — The boiler of locomotive No. 473, of the Atchison, Topeka & Santa Fe railroad, exploded, January 28, two miles east of Bellefont, Kans. Fireman J. M. Sheldon was killed.

(46.) — A blowoff pipe failed, on January 29, at James Wilson & Son's weaving mill, Philadelphia, Pa.

(47.) — On January 29 a slight rupture developed in a digester at the plant of the Penobscot Chemical Fiber Co., at Great Works, near Oldtown, Me. The damage was confined to the digester itself.

(48.) — A boiler exploded, January 29, in the electric light plant at Bedford, Ind. The damage was small, and nobody was hurt.

(49.) — A boiler used for drilling a gas well exploded, January 29, on the William Binkley farm, east of Lancaster, Ohio. The machinery was wrecked, but nobody was injured.

(50.) — Several sections ruptured, on January 29, in a cast-iron sectional boiler in an office building belonging to the William Appleton Estate, on Battery-march street, Boston, Mass.

(51.) — The head blew off a mud drum, January 30, in the feed mill owned by A. Waller & Co., at Henderson, Ky.

(52.) — On January 31 a boiler exploded in Harford & Crank's feed mill, seven miles northwest of Carrollton, Mo. Warren Crank (one of the owners) was thrown 275 yards and instantly killed. William Harford, the other owner, was injured so badly that he died three hours later. The boiler and the shed in which it stood were entirely destroyed.

(53.) — On January 31 a boiler exploded in Clark's sawmill plant, on Twelve Mile Creek, some forty miles south of Huntington, W. Va. Peter Clark, Nathan Clark and Hubert Clark were instantly killed, and John Fry was injured so badly that he died next day.

FEBRUARY, 1906.

(54.) — A tube ruptured, February 1, in a water-tube boiler at the plant of the Lehigh Portland Cement Co., Ormrod, near Allentown, Pa. Sebastian Chaliniak was injured.

(55.) — A boiler exploded, February 2, in Alpheus Wigglesworth's sawmill, at Marye's near Spottsylvania, Pa. A man named Marshall was killed, and two other persons were injured.

(56.) — Several tubes gave way, February 2, in a heating boiler in the residence of Samuel Boyd, at Appleton, Wis. The damage was slight.

(57.) — A boiler exploded, February 3, in Saulsberg's grist mill, Central City, Ky. The mill was demolished, and so also were several small buildings near by.

(58.) — Several tubes ruptured, February 3, in a water-tube boiler at the plant of the Bristol Gas & Electric Co., Bristol, Tenn.

(59.) — The boiler of locomotive No. 207 exploded, February 3, on the Grand Trunk railroad, at Turcot Village, near Montreal, P. Q. Fireman W. L. Sharp was scalded to death, and engineer E. F. Brown was thrown through the cab window and badly injured.

(60.) — A hot-water heating boiler exploded, February 3, in John Adrion's dwelling, on Kincaid street, Pittsburg, Pa. Fire followed the explosion, and the total loss, from fire and explosion, was estimated at \$1,500.

(61.) — A heating boiler exploded, February 5, in a building on Trumbull street, Hartford, Conn. The property loss was about \$500.

(62.) — A boiler exploded, February 5, in the Delahunty Dyeing Machine Co.'s works, at Pittston, Pa. Watchman Hiram Davenport was killed, and the property loss was about \$1,000.

(63.) — A boiler used for heating water exploded, February 5, in the laundry of the Hotel Anthes, at Fort Madison, Iowa. The roof of the laundry room was blown off, and the brick wall on the west side was shattered.

(64.) — On February 5 a boiler exploded in the Hatchett & Wilder sawmill, about eight miles from Roberta, Ga. Simeon Wilder and John Hatchett, owners of the plant, were both killed.

(65.) — A low-pressure boiler, used for heating, exploded, February 6, in Cowles' hotel, at South Manchester, Conn. The property loss was trifling.

(66.) — A sawmill boiler exploded, February 7, on J. W. Abercrombie's farm, between Dallas and Majorsville, W. Va. Leo McDermott was instantly killed.

(67.) — The boiler of Robert Jordan's sawmill exploded, February 7, near Graysville, Tenn. William Jordan, a son of the owner of the mill, was injured so badly that he died within a few hours. Robert Jordan and another son were also badly hurt.

(68.) — A cast-iron header fractured, February 8, in a water-tube boiler at the No. 4 mill of the Kimberly & Clarke Co., at Kimberly, Wis.

(69.) — On February 8 a boiler exploded in the Bullock Electric Co.'s plant, at Norwood (Cincinnati), Ohio. James Riley, Edward Fischer, and Augustus Boergman were seriously injured, and John Carey received slight injuries. The boiler was a water-tube one, and the explosion consisted in the rupture of one of the tubes.

(70.) — On or about February 9, a boiler exploded on the Clay Noble farm, near Taylorstown, Pa. William Stevenson received injuries which it was feared might prove fatal, and the structure in which the boiler stood was destroyed.

(71.) — A boiler exploded, on or about February 9, in the Spray Woolen Mills, Spray, N. C.

(72.) — A tube ruptured, February 10, in a water-tube boiler in the Phila-

delphia Rapid Transit Co.'s power house, at Thirteenth and Mt. Vernon streets, Philadelphia, Pa.

(73.) — A boiler exploded, February 10, in a sugar refinery on the McLeod plantation, Lockport, La. Zachary Taylor and Thomas Cantrelle were fatally injured. The property loss was small.

(74.) — A heating boiler exploded, February 10, in the Stanford Building, St. Catharine St., west, Montreal, P. Q. The building was considerably damaged, but nobody was injured, although a dance was in progress in the building at the time.

(75.) — A small boiler exploded, on or about February 10, in the Canisteo Wooden Ware factory, at Canisteo, N. Y. Nobody was injured, and the property loss was small.

(76.) — On February 11 two tubes ruptured in a water-tube boiler at the Oak Park Construction Co.'s plant, Oak Park, Ill. John Joseph and Frederick Scruton were scalded, and the boiler was considerably damaged.

(77.) — A slight rupture occurred, February 11, in a boiler at the plant of the U. S. Leather Co., Iron Gate, Va.

(78.) — On February 12 the feed pipe pulled out of the front head of a boiler in G. A. Hawkes & Co.'s shoe shop, Richmond, Me. Night watchman H. C. Kidder was scalded.

(79.) — The boiler of Northern Pacific freight locomotive No. 162 exploded, February 14, at Frazee, Minn. Fireman John Thomson was seriously and perhaps fatally injured. Engineer Arthur Green and a brakeman whose name we have not learned, were also injured, though not so badly as Thomson. The train was ditched, seven cars were demolished, and 200 feet of track were torn up.

(80.) — A tube ruptured, February 15, in a water-tube boiler at the plant of the Union Switch & Signal Co., Swissvale, Pa. Charles Martin, night engineer, was injured.

(81.) — On February 15 the boiler of locomotive No. 2150, on the Pennsylvania railroad exploded at Marysville, Pa. Engineer Elmer E. Weaver and fireman Otto Liehr were injured so badly that they subsequently died. Horace Hartman was also injured seriously but not fatally.

(82.) — A boiler exploded, February 16, in S. T. Griffin's sawmill, on the Atlantic Coast Line, six miles from Suffolk, Va. Nobody was present at the time.

(83.) — A tube ruptured, February 17, in a water-tube boiler at the plant of Charles H. Perkins, Providence, R. I.

(84.) — Two cast-iron heating boilers exploded, February 17, in the new fire headquarters building on Central Avenue, Rochester, N. Y. Nobody was injured.

(85.) — A slight boiler explosion occurred, February 21, in Victor Erath's ice factory and bottling works, New Iberia, La.

(86.) — A boiler exploded, February 21, in Mrs. Charles Brisbin's dairy, near Rocker, Mont. Henry Magins, Mrs. Brisbin, and two male employes, were injured more or less seriously, Magins losing his right foot. The building in which the boiler stood was considerably damaged.

(87.) — On February 21 a boiler exploded in McLendon's sawmill, thirteen miles from Bessemer, Ala. Several persons were seriously injured.

(88.) — On February 22 a tube ruptured in a water-tube boiler at the power plant of the Tacony & Holmesburg Traction Co., Tacony, Pa. Edwin J. Kelly and John Smith were injured so badly that they died shortly afterwards. Edward Bowers was also badly burned and scalded, but at last accounts it was thought that he would recover.

(89.) — Three cast-iron headers fractured, February 25, in a water-tube boiler at the Fulton Bag & Cotton Mills, Atlanta, Ga. Nobody was injured.

(90.) — A cast-iron section burst, February 27, in a sectional boiler in the dyeing and finishing mill of the United States Finishing Co., Providence, R. I. Fireman M. Angelo was injured.

(91.) — The boiler of a portable sawmill exploded, February 27, at West Bath, Me. Engineer Woodbury Brown was killed, and George Howe, Napoleon Bardon, and Norman Brown were injured.

MARCH, 1906.

(92.) — On March 1 a big steam drum exploded in the Magnolia laundry, Pulaski, Tenn. Claude Pigg and his father, Monroe Pigg, were killed, and Mrs. Monroe Pigg, Mrs. Mack Newton, and Clifford Harris were injured.

(93.) — The boiler of locomotive No. 20, of the North Shore railroad, exploded, March 1, at Sausalito, Cal. Daniel McCarthy was injured seriously, and at last accounts it was thought that he could not recover.

(94.) — On March 2, four headers fractured in a water-tube boiler at the cotton yarn mill of the Pocasset Combing Co., Providence, R. I.

(95.) — The boiler of a locomotive belonging to the Newman Lumber Co. exploded, March 2, at Sumrall, near Hattiesburg, Miss. Fireman Sheard Bryant was instantly killed, and engineer Thomas Riggles was fatally injured.

(96.) — A tube ruptured, March 2, in a water-tube boiler in the New York Belting & Packing Co.'s plant, at Passaic, N. J.

(97.) — A boiler exploded, March 3, in Paul Mills' flour and grist mill at Rhodenia, sixteen miles from Brandenburg, Ky. Paul Mills and Martin Greenwell were fatally injured, and Richard Humbert, Ray Vessels, G. Rhodes, Albert Rhodes, and Harry Ashcraft were injured seriously, but not fatally. The plant was demolished.

(98.) — On March 4 a tube pulled out of a sheet in a water-tube boiler at the plant of the Central Brewing Co., East St. Louis, Ill. Fireman Charles Hoffman was injured.

(99.) — On March 5 two cast-iron heating boilers gave way in the office building of the Fifty Associates, No. 8 Beacon street, Boston, Mass. Nobody was injured.

(100.) — A boiler exploded, March 5, in the Illinois Steel Co.'s plant, at Joliet, Ill. Frank Sullivan was fatally injured, and Patrick Donovan was injured seriously, but not fatally.

(101.) — A boiler exploded, March 5, in F. W. Titcomb's sawmill, Houlton, Me. William Thompson, Frank McFarlane, Nevers Dow, Extavia Myshrall,

and Sydney Goodwine were injured. The entire front of the building was demolished.

(102.) — A boiler exploded, March 6, in Benjamin's sawmill, on Cabin Hill, Hamden, N. Y.

(103.) — A heating boiler exploded, March 9, in the basement of Ruplinger & Co.'s store, Allentown, Wis. Jacob Martin was severely injured.

(104.) — The boiler of a Southern Pacific freight locomotive exploded, March 9, one mile east of Gold Run, Cal. Brakeman W. P. Frazer was killed outright, and fireman D. W. Austin and engineer F. D. Doran were fatally injured. The locomotive was wrecked.

(105.) — On March 10 the locomotive of a north bound train exploded on the I. & N. division of the Milwaukee road, near Lansing, Mich. One man was fatally injured, and two others were badly burned.

(106.) — On March 13 a boiler exploded in a sawmill at Lee City, Ky. William Walters was instantly killed, and two other persons were injured.

(107.) — A boiler exploded, on or about March 15, in Allen C. Folts' sawmill, Ashford, N. Y. Joseph Folts, a son of the owner, was seriously injured, and may not recover. The mill was wrecked.

(108.) — A slight boiler explosion occurred, March 16, in the Northwestern Ohio Bottle Co.'s plant, West Toledo, Ohio.

(109.) — On March 16 a slight boiler explosion occurred in F. R. Gillespie's grinding mill, Stamford, Conn.

(110.) — A tube ruptured in a water-tube boiler, March 17, at the power plant of the Brooklyn Heights Railroad Co., Third Avenue and 2d and 3d streets, Brooklyn, N. Y. Fireman H. McNamee was scalded.

(111.) — On March 18 a stop valve on a main steam pipe was ruptured by water-hammer action, in the Atlantic Steel Hoop Co.'s rolling mill, Atlanta, Ga. Joseph Stallings was injured.

(112.) — A blowoff pipe failed, March 19, in a boiler at the plant of the Williamson-Kuny Mill & Lumber Co., Mound City, Ill. Fireman Albert Mosely was scalded.

(113.) — A hot water boiler exploded, March 20, in the basement of A. P. Smith's residence, 341 Ramsey street, St. Paul, Minn. The property damage was estimated at \$300.

(114.) — A slight explosion occurred, March 20, in the Madison Wheel Co.'s factory, Madison, Ohio.

(115.) — On March 20 a slight explosion occurred in W. H. Ware & Co.'s sawmill, at Milton, N. H.

(116.) — A boiler exploded, March 21, in Campbell & Piller's sawmill, at Lansing, near Longview, Tex. The property loss was estimated at \$2,000.

(117.) — On March 21 a slight boiler explosion occurred in the Plattsburg Light & Power Co.'s plant, Plattsburg, Mo.

(118.) — A boiler exploded, March 22, in L. A. Bolt's cotton gin, seven miles west of Anderson, S. C. A son of the owner was killed outright, and another man was fatally injured.

(119.) — A boiler exploded, March 23, at Louis Grossman's coal mine, High Prairie, Mo. Mr. Grossman was scalded so badly that he died a few hours later. David Miller was also injured so badly that at last accounts it was not known whether he would recover or not. The boiler room and the upper works of the mine were wrecked.

(120.) — On March 24 a boiler exploded in D. M. Wertman's sawmill, near Guyton, Ga. Robert Hinely was injured so badly that he died a few hours later. Several other persons also received minor injuries.

(121.) — A boiler exploded, on or about March 27, in the sawmill of J. T. Myers & Son, at Dodge, Ore. Engineer Elvin Myers was badly scalded, and one side of the mill was wrecked.

(122.) — A slight rupture occurred, March 28, in a heating boiler at the Gilbert School, Winsted, Conn. The damage was confined to the boiler.

(123.) — A boiler exploded, March 28, in Wade's lumber mill, at Arundel, P. Q. Hugh Wade and Douglas Wade (sons of the owner) were killed, and a workman named Milet was seriously injured. The mill was completely destroyed.

(124.) — On March 28 a boiler exploded in the Lawrenceburg Gas Co.'s plant, at Newtown, near Lawrenceburg, Ind. One side of the building was wrecked, the property loss being estimated at \$1,000.

(125.) — A hot water boiler exploded, March 29, in Lee Towne's barber shop, Watertown, S. D. One man was injured, and the front of the building was thrown into the street.

(126.) — A boiler exploded, March 29, in the Luther Green wood mill, between Raymond and Andrews Settlement, Potter county, Pa. Leon Spencer and Frank Gale were seriously injured, and the building was wrecked.

(127.) — On March 30 a boiler exploded in the J. R. Weber Molding Co.'s plant, 21st street and Cass avenue, St. Louis, Mo. The damage was small. The explosion appears to have consisted in the failure of a mud drum.

ONE of the strangest cargoes a vessel could have was recently unloaded at London. It consisted of several sacks filled with dried flies, to be used in the manufacture of food for chickens, cage birds, and the like. The flies were caught on the river Amazon, by Brazilians. Flies hover in dense clouds over many of the swampy reaches of the Amazon, and they are captured by the million in gauzy nets. They are killed, dried in the sun, and then placed in sacks and shipped to London, where they are mixed with millet and other grain, and sold as chicken food, etc. Some time ago the Brazilian government, fearing that the fish in the Amazon river would suffer from the fly trade, forbade the exportation of flies. Hence the price of this strange commodity, which used to be sixpence per pound, has now risen to a shilling and a half, and often a little more.— *Scientific American*.

The Locomotive.

A. D. RISTEEN, PH.D., EDITOR.

HARTFORD, APRIL 15, 1906.

THE LOCOMOTIVE can be obtained free by calling at any of the company's agencies. Subscription price 50 cents per year when mailed from this office. Bound volumes one dollar each. (Any volume can be supplied.)

ON February 13th, Mr. Frank M. Fitch was appointed auditor of the Hartford Steam Boiler Inspection and Insurance Company. Mr. Fitch, who has been connected with the company for some years past, in the Home Department, will in the future be brought into closer relations with our agents and other employes in the field.

Agency Changes.

The office of the New York Department of the Hartford Steam Boiler Inspection and Insurance Company has been removed to 100 Williams Street, New York City.

The fearful fire at San Francisco having destroyed our offices in that city, temporary offices for our Pacific Coast Department have been opened at 464 Tenth Street, Oakland, Cal.

Obituary.

WILLIAM S. HASTIE.

It is with the deepest regret that we record the death of Mr. William S. Hastie, a prominent and highly esteemed citizen of Charleston, South Carolina, and general agent of this company for many years past. Mr. Hastie was born in New York City, June 9, 1843, and died on February 14, 1906, at his beautiful home, Magnolia-on-the-Ashley, near Charleston, after an illness of only one week. He went to Charleston when a boy of fifteen, and in the years that have passed since that time he has taken a deep and ever increasing interest in the city of Charleston, and in all that concerns its welfare and prosperity. The well-known firm of W. S. Hastie & Son was established in 1869 by Mr. Hastie and his father, and was continued under the same name after the latter's death. In the beginning the firm did only a banking and brokerage business, but in 1875 it entered upon fire insurance, and since that date it has been an important and influential force in the insurance field. In the latter part of the year 1884 the firm turned its attention also to steam boiler insurance, and early in 1885 W. S. Hastie & Son were appointed general agents of the Hartford Steam Boiler Inspection and Insurance Company. They are also agents for the Mutual Life Insurance Company, general agents for the Employers' Indemnity Company of Philadelphia, and local agents for the Queen Insurance Company of America, the Atlas Assurance Company of London, the Globe Underwriters' Agency of

New York, and the Equitable Fire Insurance Company of Charleston. Mr. Hastie was also himself agent at Summerville, South Carolina, for the Liverpool & London & Globe Insurance Company of Liverpool.

Mr. Hastie became a member of the Charleston Board of Fire Underwriters in 1875, and was elected its president in 1890, an office which he filled for six terms. Upon his retirement from the presidency, the Board, on June 19, 1896, presented him with a beautiful loving cup as a token of its esteem. He was a quiet, unostentatious man, and his loveable character endeared him to a wide circle of friends and acquaintances. His death is a distinct loss to Charleston, and his familiar figure will long be missed by his associates.

Mr. Hastie's wife is still living, and he also leaves two daughters and two sons, one of whom, Mr. C. Norwood Hastie, will continue the conduct of the business under the same firm name as heretofore.

IN the issue of the *Electrical Age* for March, we find an important paper by Mr. Franklin Riffles, on "Pipes and Joints for High Pressures." The original paper was read before the Technical Society of the Pacific Coast. Mr. Riffles describes and illustrates a number of forms of pipe couplings and joints, that are adapted for use on high pressure lines of pipe, both for steam and for water.

IN connection with the article on stay-bolts in the present issue, we desire to call attention to the interesting illustrated article in the *American Machinist* for March 29, entitled "Stay-Bolt Practice of the Pennsylvania Railroad." The article in question tells of the advances that have been made by the Pennsylvania road (mainly through the efforts of Mr. A. W. Epwright) in the manufacture of bolts and taps, and in the setting of the bolts in the sheets. It is highly instructive, and should be read by every person who has to deal with stay-bolted structures.

THOSE interested in the modern theories of the constitution of matter will find the reviews of Professor J. J. Thomson's lectures on the "Corpuscular Theory of Matter," as printed in London *Engineering* beginning with March 9, exceedingly instructive. Professor Thomson is one of the founders of the corpuscular theory, and what he has to say is well expressed and authoritative, and it also has that peculiar and indefinable charm which can apparently be given to a subject only by persons who have actually been engaged in original researches upon it. The corpuscular theory was the outcome of experiments upon vacuum tubes, and was the result of investigations conducted for the purpose of determining the physical nature of the cathode ray, and of the X-rays. It was formulated with considerable definiteness before the discovery of radium; but when that marvelous and unstable element became known, the possibilities of the experimental laboratory were enormously increased, so that the corpuscular theory grew and branched out so rapidly that its developments could hardly be followed, save by those professionally engaged in physical science. A review of what has been discovered, prepared by a man of Thomson's eminence and ability, is therefore of great value to the general student. Taken in connection with Rutherford's recent volume on "Radio-activity," these lectures will give a very good idea of the present status of the theory of the constitution of matter.

Gas engines are rapidly increasing in public favor, and are now used in many plants for which, only a few years ago, steam would have been considered the only practicable power. This tendency has been due, in no small measure, of course, to improvements in the engine itself; but the development of the modern gas producer has also been a powerful and highly important factor in the case. We desire to commend to the attention of our readers Mr. W. H. Booth's article on the "Suction Gas Producer," in the issues of *Cassier's Magazine* for March and April, which gives an excellent idea of this type of producer. The subject should be of special interest to those of an inventive turn of mind, for a fortune certainly awaits the inventor of a suction gas producer that will operate with entire success with bituminous coal.

Economy in the Use of Coal.

The tests which are being carried on at the coal-testing plant at St. Louis, under the direction of the U. S. Geological Survey, are directly designed to increase our knowledge as to the character and utilization of our coals, and especially the means which may be introduced to effect economy in their use. This is an important investigation, inasmuch as there is probably no one of our important resources which we treat more wastefully, and no one in connection with which is so colossal a saving possible of consumption. In comparison with the vista opened by the increase in the efficiency of coal consumed for power generation promised by the gas engine, the economy that can be realized in the manufacture of coke, and the spectacular saving in the use of coke in smelting that may result from Gayley's invention, the savings that we think of attaining in our other metallurgical processes sink almost to insignificance. The United States alone produces upward of 350,000,000 tons of coal per annum, worth at the mines an average of about \$1.35 per ton; when delivered to the points of consumption perhaps \$2 per ton. This huge quantity of coal is to a very large extent burned with a low degree of efficiency. For example, in the best steam practice only about 15% of its energy is utilized; this is doubled by the gas engine. Similarly, the use of gas-firing and regenerative furnaces in connection with industrial heating may halve the coal consumption. Reckoning that one-half of our present coal consumption might be effected with double the economy over the present practice, the saving would run close to \$100,000,000, a figure which startles the imagination.

We are prompted to these remarks by the receipt of Bulletin No. 2 of the Iowa Geological Survey, which contains a report on the tests of Iowa coals at the St. Louis plant, and follows the above line of reasoning. A sample of Iowa coal was found to yield 2.86 times as much energy when converted into gas and the gas burned in a gas engine as when the coal was fired directly under a boiler. The report concludes as follows:—

"The above results have great economic significance. Probably more than three-fourths of the coal mined in Iowa is used for the generation of power. This would make 4,830,740 tons of coal consumed in power production, out of the total of 6,507,655 tons mined in Iowa during 1904. Disregarding the difference in the cost of installation and operation of machinery, and with the very conservative estimate of 50 per cent. gain in efficiency of coal by means of the gas producer and gas engine above that of the boiler and steam engine,

the saving by the former method would be equal to 2,440,370 tons of coal. This at \$1.60 per ton, which was the average price at the mines of Iowa coal in 1904, would be equivalent to an annual saving to the people of the state of \$3,904,592."

This line of reasoning is, however, quite fallacious and will do much to discredit the results obtained at St. Louis, when the business men to whom such promises are held out discover that they are not at present capable of realization. In a consideration of this character the difference in the first cost, operation, and amortization of the several types of installation must not lightly be disregarded. Engineers are well aware that the gas engine attains double the efficiency of the steam engine, and in this respect the St. Louis tests tell them nothing new. They are aware, moreover, of what the tests say nothing about, namely that the costs of the gas-engine installations are so much higher all around that when reduced to dollars and cents the apparent economy practically disappears. It is highly debatable whether, at the present time, the gas engine or the steam turbine is ahead. Similarly, it frequently does not pay to substitute regenerative furnaces for direct firing, because of the increased costs of installation, operation, and amortization, although the economy in fuel may be 50 per cent. In any case the decision depends largely upon the unit cost of the fuel, which has so obvious a bearing on the question that it need not be discussed.

These questions fall entirely within the province of the engineer; the chemist and geologist are the last men to whom their analysis would be entrusted, and when they voluntarily enter upon them misconceptions are sure to result. It is not, anyway, the function of either the national or the state geological surveys to go to this length. It is far from our intention to criticize the scheme or organization of the Government Coal Testing Plant. It will, we are sure, achieve a high degree of usefulness. The most important result, in our opinion, will be the education of the public to the fact that great economy in coal is possible, and will thereby direct attention to the simple methods for effecting it to some degree, as to which many engineers can advise, *e. g.*, the installation of more efficient fire-places in connection with steam boilers, more intelligent management of the fires, etc. Moreover, much important data will be obtained as to the composition and calorific value of numerous coals, and much important information as to the behavior of certain coals in the washery, in the briquetting plant, in the coke oven, and in the gas producer, all of which will be valuable to the engineer. It is the engineer, however, who will be relied upon for the final deductions.—*Engineering and Mining Journal*.

Electric Transmission of Power.

Distance, rather than voltage, is the prime factor in the cost of transmission lines. Contemplation of that beautiful law of electric circuits, that the percentage of power lost, and also the weight of conductors, remain constant if the applied voltage varies with the length of line, sometimes obscures the fact just stated; but a cold engineering estimate brings it again to view. If electric conductors floated in mid air and did not require any particular mechanical strength, the question of line voltage would, indeed, be of first importance; but while poles, pins, and insulators are necessary, the question of line cost is not merely one of voltage, as is sometimes said.

Costs of transmission lines may be divided into those for conductors and those for supports. Within rather narrow limits the cost of conductors may be held constant by varying the voltage directly with their length. Over much wider limits the cost of supports for the conductors varies nearly as their length, whatever the voltage employed. For rather short transmissions, say under twenty or thirty miles, where the total cost of the line is only a moderate fraction of the investment in the entire plant, there is not so much reason to lay stress on the distinction between the cost of conductors, and that of supports; but on very long lines, like the recently much-talked-of 700-mile transmission to connect Victoria Falls on the Zambesi River, in South Africa, with the mines of the Rand, the cost of supports alone becomes one of the main items, if not the greatest item, of the investment.

The very fact that the weight and cost of conductors for a given percentage of loss remain constant if the voltage of transmission increases directly with their length, while the cost of supports increases at nearly the same rate as does the length of the line, implies at least a constant approach of the cost of supports to that of conductors. Were it not for the circumstance that, in practice, the cost of conductors cannot be held constant over any great range of length, the cost of supports would rise above that of line wires long before the limits of existing transmissions were reached.

If the voltage of a transmission is increased with the length, so that the weight of conductors may remain constant for the same percentage of loss, then the cross-section of each conductor must grow smaller, being only one-half as great for 200 as for 100 miles, if designed for the same amount of power. The consequent reduction of mechanical strength in the conductor thus puts a limit to the practicable voltage for many lines. On a long line of 50 miles or more, it would, in most cases, be undesirable to use a copper conductor smaller than No. 1 B. & S. gauge, though on some short transmissions of from 10 to 25 miles, wires as small as No. 4 B. & S. gauge may be found. But reduction in the size of conductors for a transmission line, due to an increase of voltage, would in many cases work no decrease in the cost of supports, in spite of the smaller weight to be carried. With the higher voltage would come the necessity for a greater distance between wires, somewhat longer poles and cross-arms, and larger pins and insulators, so that these items might fully offset the advantage of less weight in conductors.

It is now the most common, and probably the best practice, on long transmissions at high voltages, to mount each three-phase circuit on a separate pole line, where wooden poles are used. For a 50,000-volt, three-phase circuit, the conductors should be mounted on insulators at least 6 feet apart, and the length of each pole above ground should be not less than 35 feet. The standard distance between the poles may properly be 100 feet, and a fair allowance for shorter spacing on curves and corners brings their number per mile up to about sixty.

Let these poles be of good quality cedar, fit each one with a heavy cross-arm, and three steel pins carrying 50,000-volt insulators, erect them on clear solid ground, add all necessary guys and braces, string the line conductors, and a moderate cost will be \$10 per pole, or \$600 per mile, counting nothing for the line conductors or the right of way.

If three No. 1 B. & S. gauge wires are strung for a three-phase circuit on these poles, and about 5 per cent. is allowed for sag and corners, the total weight of the conductors will be 4,200 pounds per mile, costing \$630, on the basis

of 15 cents per pound. No matter how far this line may run, or how high its voltage may be raised to compensate for long distances, the cost of the conductors named will continue to be about equal to that of their supports under the stated conditions.

An actual case similar to the one suggested is that of the 65-mile line between Canon Ferry and Butte, in Montana, where each of two three-phase circuits is carried on a separate line of poles. These circuits operate at about 50,000 volts, and each consists of three No. 0 B. & S. gauge copper wires, having a combined weight of about 5,100 pounds per mile, and a consequent cost of about \$765 for that length, at 15 cents per pound. If the pole-line cost in this case corresponds to the estimate previously made, then the cost of the conductors is greater than that of the supports by only 26 per cent.

Suppose that the length of this last-named line were increased to 200 miles, and that the operating voltage were so raised that the same percentage of loss would be maintained without increasing the size of the conductors. Evidently the higher voltage would require greater distance between the conductors, longer poles and cross-arms, and more expensive insulators, all of which lead to a higher percentage of the total investment in supports.

Take another case,—the 60,000-volt transmission over a line 100 miles long to Guanajuato, Mexico. A single circuit of three No. 1 B. & S. gauge copper cables on steel towers make up this line. Each standard tower is 40 feet high and weighs 1,500 pounds, and there are twelve of these towers per mile, on straight work. In the United States these towers could probably be erected and the three conductors strung at a cost of 6 cents per pound,—\$90 per tower, or \$1,080 per mile for everything complete, except the price of the conductors and of the right of way. In Mexico, the cost may have been as high as 9 cents per pound, or \$1,620 per mile, for the same materials and labor. At the cost of \$1,080 per mile, in the United States, the steel towers of the Guanajuato line represent an investment that is greater by 70 per cent. than the cost of the No. 1 copper conductors which they support, at 15 cents per pound. If this line were increased in length to 300 or 400 miles, and the voltage raised so that conductors of the same size could be used, the relative cost of the supports would be greater rather than less. These facts it is well to bear in mind in considering transmission projects. Frequently they are overlooked.—ALTON D. ADAMS, in *Cassier's Magazine*.

SUCCESS and failure marked the efforts of Tyler Semiramus, of Mentorme, to introduce into the state of Michigan some of his new vegetable productions from Tasmania. A success was the potato-tomato plant, which produces the two kinds of vegetables on one stalk. A decided failure were the pumpkins, for they were not only useless, but distinctly dangerous. In Tasmania they are large and rich and succulent, but here they grew to be of stupendous dimensions, and their rather dark color made them absorb the burning heat of August until they fairly were turned into steam boilers and exploded, one after another, with thunderous reports, as fast as they became sufficiently filled with steam. Mr. Semiramus was out in the field one hot day when the first one blew up, and as he happened to be near it, he was blown several rods across the vines, and was severely injured.—*St. Louis Post-Dispatch*.

Hartford Steam Boiler Inspection and Insurance Company.

ABSTRACT OF STATEMENT, JANUARY 1, 1906.

Capital Stock, \$500,000.00.

ASSETS.

	Par Value.	Market Value.
Cash in office and in Bank,		\$137,832.23
Premiums in course of collection (since Oct. 1, 1905),		201,827.60
Interest accrued on Mortgage Loans,		24,082.58
Loaned on Bond and Mortgage,		952,645.00
Real Estate,		14,690.00
State of Massachusetts Bonds,	\$100,000.00	96,000.00
County, City, and Town Bonds,	368,500.00	383,880.00
Board of Education and School District Bonds,	46,500.00	48,300.00
Drainage and Irrigation Bonds,	5,000.00	5,000.00
Railroad Bonds,	1,231,000.00	1,365,000.00
Street Railway Bonds,	60,000.00	59,150.00
Miscellaneous Bonds,	65,500.00	67,305.00
National Bank Stocks,	41,800.00	57,600.00
Railroad Stocks,	177,800.00	240,900.00
Miscellaneous Stocks,	35,500.00	33,925.00
	\$2,131,600.00	

Total Assets, \$3,688,146.50

LIABILITIES.

Re-insurance Reserve,		\$1,851,706.33
Losses unadjusted,		34,614.94
Commissions and brokerage,		40,365.54
Surplus,	\$1,261,459.69	
Capital Stock,	500,000.00	

Surplus as regards Policy-holders, \$1,761,459.69 1,761,459.69

Total Liabilities, \$3,688,146.50

On December 31, 1905, the HARTFORD STEAM BOILER INSPECTION AND INSURANCE COMPANY had **92,038** steam boilers under insurance.

L. B. BRAINERD, Pres. and Treas. FRANCIS B. ALLEN, Vice-President.

J. B. PIERCE, Secretary. L. F. MIDDLEBROOK, Asst. Sec'y.

C. S. BLAKE, Supervising General Agent.

E. J. MURPHY, M. E., Consulting Engineer.

F. M. FITCH, Auditor.

BOARD OF DIRECTORS.

FRANK W. CHENEY, Treas. Cheney Brothers Silk Manufacturing Co.
 CHARLES M. BEACH, of Beach & Co.
 GEORGE BURNHAM, Baldwin Locomotive Wks., Philadelphia.
 Hon. NATHANIEL SHIPMAN, Judge United States Circuit Court, retired.
 C. C. KIMBALL, President Smyth Manufacturing Co., Hartford, Conn.
 PHILIP CORBIN, P. & F. Corbin, New Britain, Ct.
 GEORGE A. FAIRFIELD, Pres. Hartford Machine Screw Co.
 J. B. PIERCE, Secretary Hartford Steam Boiler Inspection and Insurance Co.

ATWOOD COLLINS, Prest. Security Co., Hartford, Conn.
 LUCIUS F. ROBINSON, Attorney, Hartford, Conn.
 JOHN O. ENDERS, U. S. Bank, Hartford, Conn.
 LYMAN B. BRAINERD, President and Treasurer Steam Boiler Inspection and Insurance Co.
 MORGAN B. BRAINARD, Asst. Treasurer Aetna Life Insurance Co.
 F. B. ALLEN, Vice-Prest. Hartford Steam Boiler Inspection and Insurance Co.
 CHARLES P. COOLEY, Treas. The Fidelity Company, Hartford, Conn.

Incorporated
1866.



Charter Per-
petual.

The Hartford Steam Boiler Inspection and Insurance Company

ISSUES POLICIES OF INSURANCE COVERING

ALL LOSS OF PROPERTY

AS WELL AS DAMAGE RESULTING FROM

LOSS OF LIFE AND PERSONAL INJURIES DUE TO STEAM BOILER EXPLOSIONS.

*Full information concerning the Company's Operations can be obtained at
any of its Agencies.*

Department.	Representatives.	Offices.
NEW YORK, . . .	C. C. GARDINER, JR., Manager, R. K. McMURRAY, Chief Inspector,	New York City, N. Y., 100 William St.
NORTHEASTERN, .	C. E. ROBERTS, Manager, F. S. ALLEN, Chief Inspector,	Boston, Mass., 101 Milk St. Providence, R. I., 29 Weybosset St.
PENNSYLVANIA, .	CORBIN & GOODRICH, Gen. Agents, WM. J. FARRAN, Chief Inspector,	Philadelphia, Pa., 432 Walnut St.
MARYLAND, . . .	LAWFORD & McKIM, Gen. Agents, R. E. MUNRO, Chief Inspector,	Baltimore, Md., 13-14-15 Abell Bldg. Washington, D. C., 511 Eleventh St., N. W.
SOUTHEASTERN, .	W. S. HASTIE & SON, Gen. Agts., W. M. FRANCIS, Chief Inspector,	Charleston, S. C., 44 Broad St.
SOUTHERN, . . .	LOUIS V. CLARK & Co., Gen. Agents, H. E. STRINGFELLOW, Chief Inspector,	Birmingham, Ala., 214-216 N. 20th St.
GULF,	PETER F. PESCU, General Agent, R. T. BURWELL, Chief Inspector,	New Orleans, La., 818 Gravier St.
HOME,	E. H. WARNER, General Agent, H. C. LONG, Special Agent, F. H. WILLIAMS, JR., Special Agent, F. S. ALLEN, Chief Inspector,	Hartford, Conn., 650 Main St.
SOUTHERN CONN.,	W. G. LINEBURGH & SON, Gen. Agts., J. H. RANDALL, Chief Inspector,	Bridgeport, Conn., 1 Sanford Building.
PITTSBURG, . . .	JAMES W. ARROTT, LTD., Gen. Agt., BENJAMIN FORD, Chief Inspector,	Pittsburg, Pa., 401 Wood Street.
NORTHERN OHIO,	C. A. BURWELL, General Agent, H. A. BAUMHART, Chief Inspector,	Cleveland, Ohio, 337 W. Superior Ave., N. W.
NORTHWESTERN,	H. M. LEMON, Manager, JAMES L. FOORD, Chief Inspector,	Chicago, Ill., 169 Jackson St.
SOUTHWESTERN,	VICTOR HUGO, Manager, VICTOR HUGO, Chief Inspector,	St. Louis, Mo., 319 North Fourth St.
WESTERN,	THOS. F. DALY, General Agent, T. E. SHEARS, Chief Inspector,	Denver, Col., 210-215 Ta- bor Opera House Bldg.
PACIFIC COAST, .	MANN & WILSON, General Agents, J. B. WARNER, Chief Inspector,	Oakland, Cal., 464 Tenth st.

The Locomotive

PUBLISHED BY THE HARTFORD STEAM BOILER INSPECTION AND INSURANCE COMPANY.

VOL. XXVI.

HARTFORD, CONN., JULY, 1906.

No. 3.

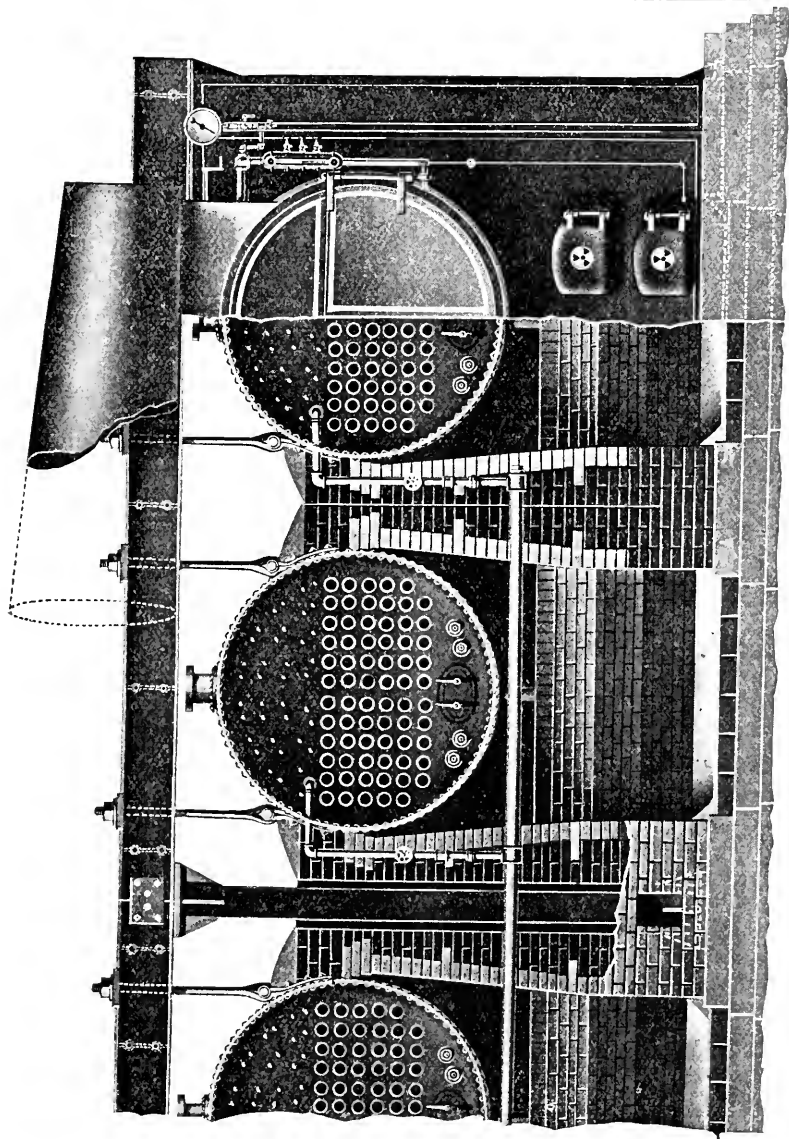

FIG. 1. — FRONT ELEVATION AND PARTIAL SECTION OF SUSPENDED BOILERS.

Suspension of Horizontal Tubular Boilers over Furnaces by Hangers.

Horizontal tubular boilers are commonly set so that their weight rests upon the side walls of the settings, through lugs that are riveted to the shells of the boilers. This mode of support has been frequently illustrated and described in *THE LOCOMOTIVE*. In certain parts of the country, however, it is becoming common to support such boilers, not upon the brick walls of the settings, but by suspending them, by means of hangers, from I-beams or channel bars, which pass transversely over the tops of the boilers, and themselves rest upon iron posts or columns that convey the weight of the boilers directly to the foundation, without permitting any of it to come upon the settings.

We have prepared plans and specifications for many installations of this character, and experience has shown that there is no reason why such a mode of support cannot be used with entire satisfaction, provided proper attention is paid to certain essential points in design and construction, which we are about to discuss in the present article.

A method of suspending boilers from I-beams running transversely across the boilers, overhead, was described in the issue of *THE LOCOMOTIVE* for April, 1889, though in the application there illustrated the purpose was more particularly to show how two or more boilers might be suspended over one and the same furnace. (In the present article we are to consider settings in which each boiler has its own individual furnace.) As long ago as March, 1881, we also printed an article upon the support of boilers by hangers, pointing out, in that place, that when the boilers are of great length, it is essential to success that attention should be paid to the liability of the shells to rise up at the ends (or belly down in the middle), from unequal expansion; the heat to which such boilers are exposed being always more intense along the bottom of the shells than it is elsewhere. The deformation of the shell, here indicated, causes an unequal distribution of the stresses in the hangers, when more than four hangers are used to each boiler, unless special precautions are taken to secure equality of the tensions, as pointed out in the article of 1881. Upon shorter boilers, where the effect of the unequal expansion of the shell would be of much less importance, six hangers, arranged in three pairs, have been used to some extent, without any provision for the equalization of the tensions upon the hangers. Experience has shown, however, that this is not good practice under any circumstances. Not more than two pairs of hangers should be employed (as shown in the present engravings) upon horizontal tubular boilers of any ordinary length; and when, by reason of extraordinary length (as in the old-fashioned cylinder boilers of iron works), two pairs of hangers appear to be inadequate, special designs must be prepared, in which provision is made for the equalization of the stresses upon the hangers. In the present article we shall consider only the common case of the ordinary horizontal tubular boiler for which two pairs of hangers are quite sufficient.

GENERAL DESCRIPTION OF THE SETTING HERE ILLUSTRATED.

In Figs. 1 and 2 we illustrate the Hartford Steam Boiler Inspection and Insurance Company's standard method of supporting horizontal tubular boilers (one boiler over each furnace) by suspension from overhead I-beams. We do not publish this as the only design that we should accept, but because we have

found it to work satisfactorily, and because, in describing it, we shall be enabled to call attention, in an intelligible manner, to certain essential points which must be attended to in *any* successful design that is intended for this same purpose. In special cases, we introduce modifications in this setting, ourselves; but the design here shown is the one that is preferred by our designing department, and in departing from it in order to meet local conditions, or to conform with the preferences of our patrons, we adhere to such of its elements as experience has shown to be of profound importance. Prime among the features that we

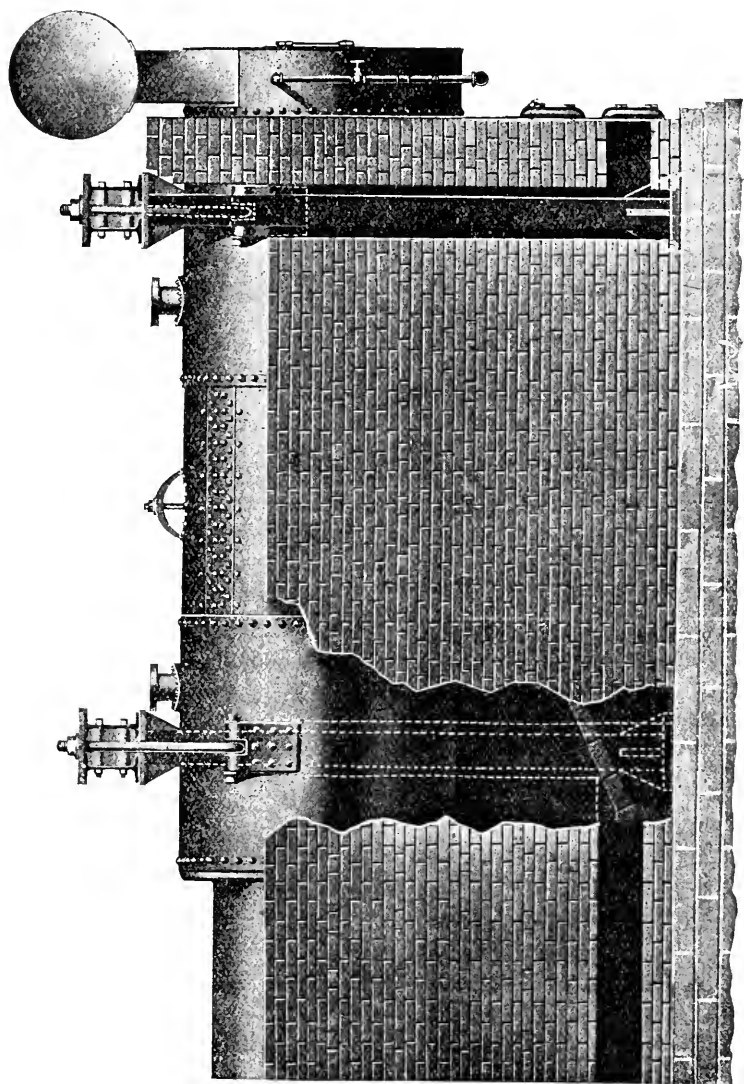

FIG. 2. — SIDE VIEW OF SUSPENDED BOILER.

retain under all circumstances is the provision, under some form or other, for the cooling of the columns that support the beams from which the boilers are suspended, as will presently be explained in detail.

Fig. 1 shows a front elevation of several horizontal tubular boilers, with portions of the settings in section. Heavy I-beams pass across the battery, overhead, and from these beams hangers pass down to the boilers, as shown. The I-beams from which the boilers are suspended rest, at their ends, upon columns of cast or wrought iron, which transfer the weight directly to the foundation of the setting. At the outside wall of each battery thus fitted up, the iron supporting columns are built into the brickwork of the setting, in such a way that their outer surfaces come flush with the outer face of the setting wall. The brickwork of the setting comes solidly into contact with these outside columns, and gives them lateral support.

The outside columns are exposed to the free air of the boiler room, and can never become overheated. Columns which come *within* the setting, however, such as the one shown towards the left in Fig. 1, must *never* be built solidly into the brickwork. These internal columns, it is plain, are each between two furnace fires; and if no provision is made for cooling them, they are very likely to become overheated, and hence to warp and destroy the walls of the settings. We are well aware that such columns are sometimes built solidly into the brickwork without giving trouble; but to build them in thus is bad practice, and we have seen many cases in which the brickwork was destroyed, and the boilers therefore rendered unserviceable, by the warping of the columns from overheating. The causes of failure in batteries of boilers with overhead suspension are mainly these: (1) Lack of means for preventing the columns from overheating, (2) the use of columns deficient in strength or stiffness, and (3) the use of I-beams (or equivalent channel bars) of insufficient strength or rigidity. These points will presently be considered in further detail. It may here be said, however, that the necessity of sufficient strength in the supporting devices is far more evident than the necessity of proper provision for cooling the columns; and that is why we desire to lay especial emphasis upon this latter item.

COOLING OF THE SUPPORTING COLUMNS.

In the design shown in Figs. 1 and 2, the cooling of the columns is provided for by leaving a two-inch space all around each interior column, between it and the brickwork. This space is indicated around the column towards the left in Fig. 1, and it is also shown in Fig. 2, which represents a longitudinal section of the setting, taken midway between the central and left-hand boilers, in Fig. 1. In Fig. 2, the column at the front end of the boiler is shown in full, while that towards the rear end is indicated in dotted lines. In each case the two-inch air space around each column is plainly shown. This space must be left open at the top, and at the bottom it should be provided with a horizontal duct or flue, leading to the front or rear of the setting, as indicated in Fig. 2. The column near the front of the boiler has a duct leading to the front, and that towards the back end has a similar one leading out through the rear wall. The bricks over these ducts are supported by pieces of boiler plate, or by some other equivalent method, and a register, or grating, should be placed in the open ends of the horizontal ducts, to keep out rats and other small animals, and to prevent the ducts from becoming choked with debris of any kind, that may find its way to the

boiler house floor. When a battery of boilers, set as here shown, is in operation, the heat from the furnaces warms the air in the spaces around the columns, and this brings about a circulation, up around the columns and in through the ducts at the bottom; and it is this circulation which keeps the columns cool. The registers in the ends of the ducts should be open enough so that they will not materially check the flow of air; and after the boilers have been in operation for a time, the existence of the circulation should be verified at intervals by applying a candle flame to the registers, or by blowing smoke towards them, or in some similar way. Dust and dirt are likely to fall into the vertical air spaces, from above, eventually choking them and checking the cooling circulation. Accumulations of this kind, when their presence becomes known by the candle-flame test or otherwise, should be carefully removed.

The horizontal ventilating ducts, or flues, leading to the spaces around the columns, are usually 8 inches wide and 10 inches high, as designed by the Hartford Steam Boiler Inspection and Insurance Company. The effectiveness of the air-circulation in keeping the columns cool, in the form of setting here shown, is proved, not only by the test of a lengthy and uniformly successful practical experience with such settings, but also by direct thermometric measurements. Thus in one plant that we examined, in which the boilers were carrying a steam pressure of 130 pounds per square inch, a thermometer dropped into the forward vertical air space to a point opposite the grate bars and allowed to remain in position for ten minutes, showed a temperature of 140° Fahr. This test was repeated three times, with the same result. Three readings were similarly taken in the same air space, with the thermometer half way between the grate bars and the top of the setting, the temperature in this position being 170° in each case. In another plant, where the boilers carry steam at from 60 to 70 pounds per square inch, the following results were obtained, the thermometer being exposed fifteen minutes in each case: In the forward vertical duct, at a height of one foot above the grate bars, the temperature found was 125° Fahr; and in the rear vertical duct, just above the top of the bridge wall, the reading was 194° . Although the pressure was not very great in this latter plant, the boilers were doing heavy duty, and the firing was correspondingly brisk.

Instead of ventilating the columns that support the I-beams by means of ducts leading to the spaces around the columns, as shown in Figs. 1 and 2, we have sometimes designed the brickwork so that the boilers of the battery are really set in pairs, with separate settings, spaced about one inch apart where the columns come. In this case each interior column has a two-inch space all around it, as before, but the horizontal ducts shown in Figs. 1 and 2 are omitted, and the necessary ventilation for the cooling of the columns is then obtained by circulation through the inch-wide space that remains between the walls of the settings. This method gives good results, also; the main thing, so far as the temperature of the columns is concerned, being to provide *some* adequate means of preventing the columns from becoming heated to a point where they are liable to buckle and warp. The supporting columns being hollow, it might be thought that an efficient air circulation could be provided through their *interior*, so that the two-inch space outside of the columns, and between them and the brickwork, could be safely omitted. We understand, however, that this plan has not been found satisfactory, and we therefore cannot recommend it as a substitute for the one here shown.

SIZE AND SHAPE OF THE SUPPORTING COLUMNS.

The supporting columns should be securely bolted to the foundation of the setting, and we prefer square columns of cast-iron to those of any other form or material. If cast-iron columns cannot be had conveniently, we should not reject columns of wrought iron or steel, if they were of proper form and strength. So far as the shape of the column is concerned, our preference for the square form is based in considerable measure upon the fact that this shape appears to afford a better support, at the top, for the I-beams. If vertical lines be drawn through the webs of the I-beams in Fig. 2, it will be seen that these lines fall just outside of the material of the central part of the column. This means that the load sustained by the beams comes upon the columns just outside of their line of most effective resistance. In a square column the material of the central part of the column comes more nearly in a line with the load transmitted by the I-beams than is possible in a circular column of the same diameter; and hence

TABLE I. — SIZES OF SQUARE CAST-IRON COLUMNS FOR SUSPENDED BOILERS.

Diameter and Length of Boiler.	DIAMETER AND THICKNESS OF COLUMNS.		
	One Boiler.	Two Boilers.	Three Boilers.
48 in. × 16 ft.	6 in. × $\frac{5}{8}$ in.	6 in. × $\frac{3}{4}$ in.	6 in. × $\frac{7}{8}$ in.
54 in. × 16 ft.	6 in. × $\frac{3}{4}$ in.	6 in. × $\frac{7}{8}$ in.	6 in. × 1 in.
60 in. × 18 ft.	6 in. × $\frac{3}{4}$ in.	6 in. × $\frac{7}{8}$ in.	6 in. × 1 in.
66 in. × 16 ft.	7 in. × $\frac{3}{4}$ in.	7 in. × $\frac{7}{8}$ in.	7 in. × 1 in.
66 in. × 18 ft.	7 in. × $\frac{3}{4}$ in.	7 in. × $\frac{7}{8}$ in.	7 in. × 1 in.
72 in. × 16 ft.	8 in. × $\frac{3}{4}$ in.	8 in. × $\frac{7}{8}$ in.	8 in. × 1 in.
72 in. × 18 ft.	8 in. × $\frac{3}{4}$ in.	8 in. × $\frac{7}{8}$ in.	8 in. × 1 in.
78 in. × 16 ft.	8 in. × $\frac{3}{4}$ in.	8 in. × $\frac{7}{8}$ in.	8 in. × 1 in.
78 in. × 18 ft.	8 in. × $\frac{3}{4}$ in.	8 in. × $\frac{7}{8}$ in.	8 in. × 1 in.
84 in. × 16 ft.	8 in. × 1 in.	8 in. × 1 in.	8 in. × $1\frac{1}{8}$ in.
84 in. × 18 ft.	8 in. × 1 in.	8 in. × 1 in.	8 in. × $1\frac{1}{8}$ in.

the square section appears to be the more logical form. Rectangular columns are sometimes used, with the object of bringing part of the material of the body of the column in a direct line with the load. We do not regard them as essential, however, and we sometimes specify circular columns, when square ones cannot be conveniently had.

The accompanying table (Table I) shows the sizes that we commonly recommend for square cast-iron columns for supporting the I-beams in settings such as are here illustrated. The first column of the table gives the diameters and lengths of the boilers to be supported; the second gives the diameter and thickness of the cast-iron columns required, when there is to be only one boiler between supports; the third gives the corresponding diameter and thickness when two boilers are to be suspended between supports (as in Fig. 1); and the fourth gives the sizes when three boilers are to be suspended between supports. We do not recommend hanging more than three boilers from one set of beams, that are supported only at the ends.

The sizes given in the table were obtained by computation, checked and substantiated by experience; and we do not regard them as at all excessive. If square cast-iron columns of these dimensions are not employed, the support that is used in place of them must be of similar strength and stiffness. We have seen cases in which vertical sections of I-beams were used instead of the columns here prescribed, and in which the outside supports, not exposed to the heat of the fires, had bowed out at the middle by three inches, after a short term of service, and merely from the weight of the boilers and their contents.

SIZES AND WEIGHTS OF THE I-BEAMS.

The I-beams from which the boilers are hung must be strong enough to sustain their load without any serious deflection. The following sizes will be found satisfactory for boilers of ordinary weight, as designed by the Hartford Steam Boiler Inspection and Insurance Company. Boilers of unusual length or plate-thickness will require stronger beams, whose sizes may be determined by the method presently to be given.

TABLE II.—SIZES OF I-BEAMS FOR SUSPENDED HORIZONTAL TUBULAR BOILERS.

Diameter of Boiler.	Length of Tubes.	Number of Boilers.	SIZE OF I-BEAM	
			Depth.	Weight per Foot.
48 in.	18 ft.	1	6 in.	12 $\frac{1}{4}$ lbs.
54	"	1	6	12 $\frac{1}{4}$
60	"	1	6	12 $\frac{1}{4}$
66	"	1	7	15
72	"	1	8	18
78	"	1	8	18
84	"	1	9	21
48 in.	18 ft.	2	9 in.	21 lbs.
54	"	2	10	25
60	"	2	12	31 $\frac{1}{2}$
66	"	2	12	40
72	"	2	15	42
78	"	2	18	55
84	"	2	18	55
48 in.	18 ft.	3	12 in.	31 $\frac{1}{2}$ lbs.
54	"	3	15	42
60	"	3	15	45
66	"	3	18	55
72	"	3	20	65
78	"	3	24	80
84	"	3	24	80

We have found the sizes given in the table adequate, but we do not consider them excessive; and lighter ones should not be used, in our judgment. It is to be noted that *four* of these I-beams are required in each case, one pair at the front and one at the rear, as illustrated in Fig. 2. The beams constituting each pair are held at the proper distance from each other by means of "separators", which are shown between the beams in Fig. 2, and also by means of dotted lines

in Fig. 1. One of these separators should be placed near each end of each pair of beams, and others should be placed in intermediate positions, at intervals not exceeding five feet. Bolts pass through the separators, near the top and bottom, the nuts on which hold the beams securely against the separators. Heavy cast-iron bearing plates rest upon the I-beams, and through them pass the hangers, which are threaded at the upper end, and fitted with large washers and heavy nuts.

In the place of I-beams over the boilers, channel bars may be used if they can be had more readily. We prefer the I-beams, but there is no serious objection to the channel bars, if they are sufficiently heavy and are correctly placed. Data for determining the necessary sizes of such channel bars will be found in the final section of the present article.

In erecting a battery of boilers in the manner here shown, care must be exercised to prevent the I-beams from interfering with the steam piping, or with the safety-valve. We have one case in mind, in which our inspector, when examining a newly erected plant, found the safety-valve in contact with one of the I-beams, and upon chipping the beam away a little, he found that the valve followed the chipping until he had cut quite a sensible depression into the beam. The boiler had evidently been forced into position, regardless of the fact that the safety-valve was jammed against the beam. Great care should be exercised to prevent anything of this nature, and to detect it, if it exists; for there should be no stress thrown upon steam piping or valves, save that which is due to the steam pressure.

There are a number of satisfactory methods for attaching the lower ends of the hangers to the shells of the boilers. The extremities of the hangers may be formed into hooks, for example, which may be made to enter wrought-iron ears that are forged up and riveted to the shells, as illustrated in *THE LOCOMOTIVE* for April, 1889. In case the forged ears are considered too expensive, we showed, at the same time, an alternative device consisting of a forged loop, which is to be riveted to the shell, and to receive the ends of the hangers. In each of these methods of support, however, the hangers must be formed into hooks at their lower ends, or else they must be made in U-form, with both ends of the U running up above the I-beams, and both provided with nuts and washers. In the illustrations of the present article we show a form of attachment which we now commonly recommend in preference to those just described, and which has the advantage over them, both in cheapness and in strength. In this form of attachment, the lug that is riveted to the boiler is formed by bending a piece of boiler plate over upon itself, so as to leave space, at the bent end, for the insertion of a pin, as will be clearly understood by reference to the engravings. The bent piece of boiler plate is riveted to the shell by nine rivets, and the hanger has an eye (instead of a hook) forged upon its lower end, through which a stout pin passes. The pin should have one of its ends enlarged, or upset, and its other end should be provided with a transverse locking pin, or key, to prevent any possibility of the larger one working out of position. An eye is greatly to be preferred to a hook, on the lower end of the hanger; for the eye is a stronger form, in spite of the fact that it involves a weld. We have known the hooks to gradually straighten out, in practice, so as to let the boilers down. The U-shaped hanger, with two nuts and washers, referred to above, may be used in the place of the eye-bar form, if desired.

DETERMINATION OF THE SIZE OF THE I-BEAMS.

The proper size and weight for the I-beams may be found directly, in Table II, for all ordinary sizes of horizontal tubular boilers. In order to make the present article more complete, however, we proceed to explain the way in which these sizes may be calculated. The method employed is as follows: The weight of the boilers, together with that of their contents and fittings, being supposed to be known, and the manner in which they are supported from the beams being also known, we first calculate the maximum bending stress that a load of this magnitude will produce in the beams. This bending stress (or "bending moment", as it is technically called,) will be expressed in "inch-pounds"; an inch-pound being the twisting effort or bending moment, that is produced by a force of one pound, when acting at the end of a lever one inch long.

Having calculated the maximum bending moment, in inch-pounds, that the actual load that is to be carried will produce in each beam, we next look over the trade sizes of beams, to see what size can sustain this calculated bending moment safely. The safe bending moment for each trade size is known by means of calculations made by the manufacturers, and based upon the form of cross-section of the beam, and the elastic properties of the material of which the beam is made.

In calculating the maximum bending moment that a given load will produce, the procedure will vary according to the number of boilers to be supported between consecutive pairs of columns. We shall therefore take up, separately, the cases in which there are one, two, and three boilers, respectively, suspended from the beams, between supports. In every instance we shall assume that each boiler is suspended by two pairs of hangers, and that the tension is the same upon the forward hangers as it is upon the rear ones. This last condition may not be precisely fulfilled, in actual practice, but it is so nearly true that we may assume it to be exact, for our present purposes. Finally, we shall omit the weight of the beam itself from consideration. Strictly speaking we should take this weight into account, since it is a part of the load that the beam must carry, and it adds to the bending moment that the beam must sustain. In every practical case, however, the part of the bending moment that is due to the weight of the beam itself is a small fraction of the total bending moment, and so may be safely provided for by adopting a beam slightly stronger than the calculation calls for.

BENDING MOMENT DUE TO A SINGLE BOILER.—To find the maximum bending moment that the beams will have to sustain, when there is but one boiler, placed centrally between the supports, the rule is as follows: Multiply the total weight of the boiler and its contents and fittings, in pounds, by the distance, in inches, from one of the hangers to the nearest point of support of the beam, and divide the product by eight. The result is the maximum bending moment, in inch-pounds, that will have to be sustained by each single beam. (We assume here, and throughout this article, that the load is sup-

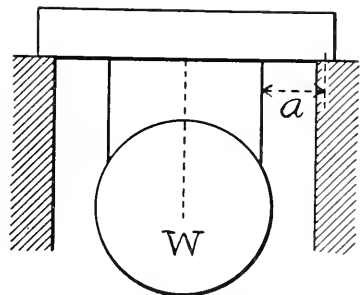

FIG. 3.—ONE BOILER BETWEEN SUPPORTS.
(In Figs. 3, 4, and 5 W signifies the total weight of one boiler.)

ported by two pairs of beams, arranged substantially as shown in Fig. 2.) In Fig. 3, if a is given in inches and W in pounds, then the maximum bending moment which each single beam will have to sustain is $Wa/8$.

BENDING MOMENT DUE TO A PAIR OF BOILERS.—To find the maximum bending moment when there are two boilers between supports, placed symmetrically, as shown in Fig. 4, the rule is as follows: Multiply the total weight of one of the boilers (including its contents and fittings), in pounds, by the horizontal distance, in inches, from the center line of one of the boilers to the nearest point of

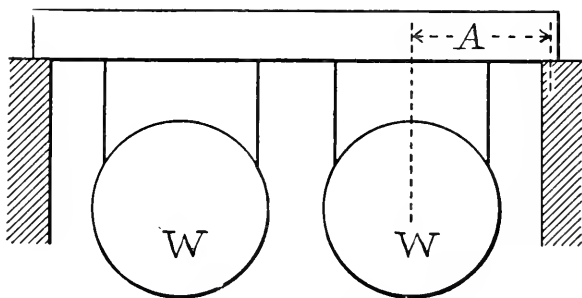

FIG. 4. — TWO BOILERS BETWEEN SUPPORTS.

support, and divide the product by four. The result is the maximum bending moment, in inch-pounds, that will have to be sustained by each single beam. Thus in Fig. 4, if A is given in inches, and W in pounds, then the maximum bending moment that each single beam will have to sustain is $WA/4$.

BENDING MOMENT DUE TO THREE BOILERS.—To find the maximum bending moment when there are three boilers between supports, one placed centrally and the other two placed symmetrically on either side of the central one, the rule is as follows: To the horizontal distance, in inches, from one of the hangers of

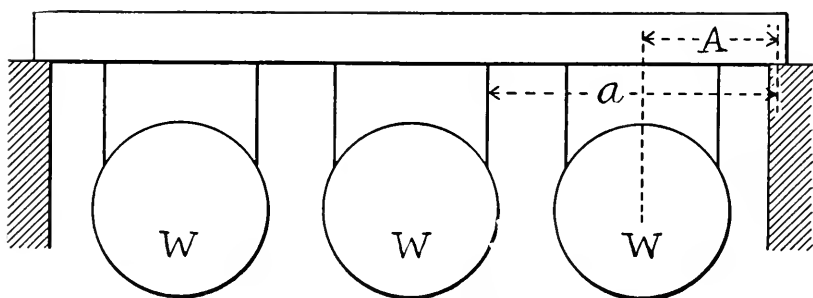

FIG. 5. — THREE BOILERS BETWEEN SUPPORTS.

the central boiler to the nearest point of support, add twice the horizontal distance, also expressed in inches, from the central line of one of the outside boilers to the nearest point of support. Multiply the sum by the weight of one of the boilers (together with its contents and fittings), in pounds, and divide by eight. The result is the maximum bending moment, in inch-pounds, that will have to be sustained by each single beam. In Fig. 5, for example, if a and A are given in

inches, and W in pounds, then the maximum bending moment that each single beam will have to sustain is $W(a + 2A)/8$. It is to be noted that this rule is a consequence of the first two. For when there are three boilers between supports, arranged as described above, we may determine the bending moment by two successive steps, as suggested in Figs. 6 and 7. That is, we may first compute the maximum bending moment by the first rule, as though the central boiler were the only one present (Fig. 6), and then by the second rule, as though the two end ones were alone present (Fig. 7). The sum of the two moments so found will be the total maximum bending moment desired. It is easy to see that the result so obtained is identical with that given by the third rule, above.

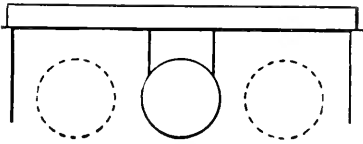

FIG. 6.

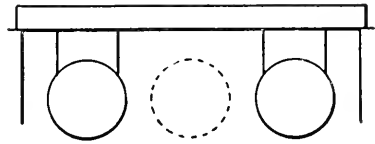

FIG. 7.

MOMENT OF RESISTANCE OF AN I-BEAM.—When an I-beam is loaded in the manner shown in Figs. 1 and 2, its uppermost fibers are in compression, and its lowest ones are in tension. It is usual to consider that the intensity of the compression in the uppermost fibers is equal to the intensity of the tension in the lowest ones, since this would be accurately the case if the material of which the beam is composed possessed the ideal properties that it is assumed to possess, in the theory of elasticity; and the greatest tension, per square inch of cross-sectional area, that exists in the beam under given conditions of loading, is called the "maximum fiber tension". When we know the shape of the cross-section of the beam, we can compute (by methods given in the books on theoretical mechanics) the maximum bending moment that the beam can sustain, without its maximum fiber tension exceeding a given limit. This calculation has been performed with great care, by the manufacturers of I-beams, for all the trade sizes and shapes, and for the maximum fiber tensions that are found, in practice, to be safe. In the beams that are used in the construction of the steel frames of buildings, it is usual to allow a maximum fiber tension of 16,000 pounds per square inch, while in bridge work, where the load is variable, it is customary to limit the maximum fiber tension to 12,500 pounds per square inch. In beams that are to be used for the support of steam boilers, we prefer to limit the maximum fiber stress to 12,500 pounds, the value admitted for bridges; and the tables that accompany this article are computed on that basis. The maximum bending moment that a given beam can support, without its maximum fiber tension exceeding a given limit, may be conveniently called the "moment of resistance" of the beam, for the given limit of fiber tension.

In Table III we give, in the column headed **M**, the moment of resistance, in inch-pounds, of I-beams of various sizes and weights, for a maximum fiber tension of 12,500 pounds per square inch. To find the size of I-beams required to give proper support to one, two, or three boilers, suspended in accordance with the plans shown in the engravings accompanying this article, we first find (by one of the rules given above) the maximum bending moment that the beam will have to sustain. We then look for this bending moment among the moments of re-

TABLE III. — MOMENTS OF RESISTANCE AND SECTION-MODULI OF I-BEAMS.

SIZE AND WEIGHT OF BEAM.				M.	S.
Depth in Inches.	Weight per foot, in Pounds.	Width of flange, in Inches.	Thickness of web, in Inches.	Moment of resistance, in Inch-Pounds.	Section Modulus.
24	100.	7.254	0.754	2,479,000	198.4
24	90.	7.131	0.631	2,332,000	186.6
*24	80.	7.000	0.500	2,175,000	174.0
20	90.	7.137	0.737	1,947,000	155.8
*20	80.	7.000	0.600	1,833,000	146.7
20	75.	6.399	0.649	1,586,000	126.9
20	70.	6.325	0.575	1,525,000	122.0
*20	65.	6.250	0.500	1,462,000	117.0
18	70.	6.259	0.719	1,280,000	102.4
18	65.	6.177	0.637	1,224,000	97.9
18	60.	6.095	0.555	1,169,000	93.5
*18	55.	6.000	0.460	1,105,000	88.4
15	90.	6.577	0.987	1,409,000	112.7
*15	80.	6.400	0.810	1,326,000	106.1
15	70.	6.194	0.784	1,106,000	88.5
*15	60.	6.000	0.590	1,015,000	81.2
15	55.	5.746	0.656	852,000	68.1
15	50.	5.648	0.558	806,000	64.5
15	45.	5.559	0.460	760,000	60.8
*15	42.	5.500	0.410	736,000	58.9
12	50.	5.489	0.699	632,000	50.6
12	45.	5.366	0.576	595,000	47.6
*12	40.	5.250	0.460	560,000	44.8
12	35.	5.086	0.436	476,000	38.0
*12	31.5	5.000	0.350	450,000	36.0
10	40.	5.099	0.749	397,000	31.7
10	35.	4.952	0.602	366,000	29.3
10	30.	4.805	0.455	335,000	26.8
*10	25.	4.660	0.310	305,000	24.4
9	30.	4.609	0.569	283,000	22.6
9	25.	4.446	0.406	255,000	20.4
*9	21.	4.330	0.290	236,000	18.9
8	25.5	4.271	0.541	214,000	17.1
8	20.5	4.087	0.357	189,000	15.1
*8	18.	4.000	0.270	178,000	14.2
7	20.	3.863	0.458	151,000	12.1
*7	15.	3.660	0.250	129,000	10.4
6	17.25	3.575	0.475	109,000	8.74
*6	12.25	3.330	0.230	91,000	7.26

sistance tabulated in Table III. In general, the exact bending moment given by the rule will not be found in the table; but any beam having a moment of resistance *greater* than the maximum bending moment as calculated by the foregoing rules, will be safe, and may be used.

The data upon which Table III is based are from the handbook issued by the Carnegie Steel Company; the sizes marked with a star (*) are "standard" sizes, and the others are "special" sizes. While the table relates particularly to Carnegie beams, it may be applied, without material error, to beams of similar depth and weight, from any other standard makers. Indeed, many of the sizes are supposed to be identical, as turned out by different makers; the identity in these sizes arising from the adoption, by the makers, of standard forms of section, recommended by the Association of American Steel Manufacturers.

As an example of the use of the table in selecting the size of I-beams to be used in a given job, take the following: Let it be required to support a pair of boilers in the way shown in Figs. 1 and 2, each boiler being 72 inches in diameter with 18-foot tubes, and let us further suppose that it is known, either from calculation or from previous experience, that each boiler will weigh 40,000 pounds, including its fittings and a quantity of water sufficient to fill it up to the proper working level. In the form of setting adopted by the Hartford Steam Boiler Inspection and Insurance Company for boilers of this size, and illustrated in Figs. 1 and 2, the distance *A* (in Fig. 4) is approximately 59 inches. Hence by the foregoing rule for two boilers, the maximum bending moment to be sustained by each beam is found thus: $40,000 \times 59 = 2,360,000$, and $2,360,000 \div 4 = 590,000$ inch-pounds, which is the maximum bending moment desired. By reference to column **M** in the table, we see that a 12-inch beam, weighing 45 pounds to the foot, has a moment of resistance greater than this, and hence may be used for the work. This beam is not a standard size, however, and it will be seen that the next stronger standard size is a 15-inch beam, weighing 42 pounds per foot. The 15-inch beam, weighing 42 pounds per foot, is adopted in Table II, because it is not only a standard size, but is also stronger and lighter than the one which comes nearest to the calculated bending moment, in Table III.

In the column designated by **S** in the table we give what is called the "section modulus" of each beam. The section modulus is used in calculating the maximum fiber tension that actually exists, in a beam loaded in a given way. For this purpose we determine the maximum bending moment due to the load, as explained above, and we divide this maximum bending moment (expressed in inch-pounds) by the section modulus, **S**, of the beam, and the quotient is the greatest fiber tension, in pounds per square inch of section, that exists in the given beam, under the given load. By way of illustration, let us calculate the maximum fiber tension in the 15-inch, 42-pound beam that is recommended in the last paragraph for use in supporting the two boilers in the example just given. We found that the bending moment due to the two boilers is 590,000 inch-pounds; and for a beam 15 inches deep, and weighing 42 pounds per foot, we see (in column **S** of the table) that the section modulus is 58.9. Then $590,000 \div 58.9 = 10,017$ pounds per square inch, which is the greatest fibre tension in the 15-inch, 42-pound beam, due to the actual load upon it.

USE OF CHANNEL-BARS IN THE PLACE OF I-BEAMS.

As we have said above, we prefer I-beams for supporting suspended boilers, but we do not refuse to pass channel-bars for the same purpose, if they are put in properly, and are of proper depth and weight. To aid in the determination of the size that channel-bars should have, we append a table (Table IV) giving the moments of resistance and the section moduli of such bars. This table is in all respects analogous to Table III, and its use will be sufficiently understood from the numerical example given above, in connection with Table III.

It must be understood, throughout the foregoing article, that the boilers are assumed to be set in substantial accordance with the design shown in Figs. 1 and 2. This point is of special importance in computing the sizes of the beams or channel bars; for while the beams or channels that are indicated by the method here given are stiff enough for the spans that occur in the Hartford settings, with greater spans these same beams may be subject to unreasonable deflection, under the same load; and in such cases heavier beams would be required. Some of the beams in Table II are lighter than we have recommended in the past, the lighter sizes being now adopted because experience indicates that the earlier ones possessed a factor of safety unnecessarily large.

TABLE IV. — MOMENTS OF RESISTANCE AND SECTION-MODULI OF CHANNEL-BARS.

SIZE AND WEIGHT OF CHANNEL-BAR.				M.	S.
Depth in Inches.	Weight per foot, in Pounds.	Width of flange, in Inches.	Thickness of web in Inches.	Moment of resistance in Inch-Pounds.	Section Modulus.
15	50.00	3.720	0.720	671,000	53.7
15	40.00	3.524	0.524	579,000	46.3
*15	33.00	3.400	0.400	521,000	41.7
12	40.00	3.418	0.758	410,000	32.8
12	30.00	3.173	0.513	337,000	26.9
*12	20.50	2.940	0.220	267,000	21.4
10	30.00	3.036	0.676	258,000	20.6
10	20.00	2.742	0.382	197,000	15.7
*10	15.00	2.600	0.240	167,200	13.4
9	25.00	2.815	0.615	195,400	15.7
9	20.00	2.652	0.452	168,900	13.5
*9	13.25	2.430	0.230	131,400	10.5
8	21.25	2.622	0.582	149,400	11.9
8	16.25	2.439	0.399	124,700	10.0
*8	11.25	2.260	0.220	100,900	8.1
7	19.75	2.513	0.633	118,500	9.5
7	14.75	2.303	0.423	97,100	7.8
*7	9.75	2.090	0.210	78,300	6.0
6	13.00	2.160	0.440	72,100	5.8
6	10.50	2.038	0.318	63,000	5.0
*6	8.00	1.920	0.200	54,200	4.3

The Locomotive.

A. D. RISTEEN, PH.D., EDITOR.

HARTFORD, JULY 15, 1906.

THE LOCOMOTIVE can be obtained free by calling at any of the company's agencies. Subscription price 50 cents per year when mailed from this office. Bound volumes one dollar each. (Any volume can be supplied.)

Obituary.

NATHANIEL SHIPMAN.

With the deepest sorrow we record the death of Nathaniel Shipman, LL.D., which occurred on June 26, 1906, at his home in Hartford, Connecticut. He had been eminent as a lawyer and jurist for many years, and had been a director of the Hartford Steam Boiler Inspection and Insurance Company for more than seventeen years, having been elected to that office on February 19, 1889. He was born at Southbury, Connecticut, August 22, 1828, and was the son of Thomas L. and Mary T. (Deming) Shipman. Upon leaving the common schools, he entered Yale College, from which he was graduated in 1848. He then took up the study of law, was admitted to the bar in Hartford county, Connecticut, in 1850, and continued in the active practice of law in the city of Hartford for twenty-three years, being associated with Mr. H. K. W. Welch, under the firm name of Welch & Shipman, until Mr. Welch's death in 1870. On April 16, 1873, Mr. Shipman was appointed a United States district judge, by President Grant; and on March 17, 1892, he was promoted to the position of judge of the United States circuit court of appeals, which position he held until his resignation on April 22, 1902, after a term of judicial service of approximately thirty years. Judge Shipman was one of the seven citizens who met in the late Joseph R. Hawley's office, in 1856, to form the Republican party of Connecticut, and he was the last survivor of the seven. He was a member of the Connecticut House of Representatives in 1857, and from 1858 to 1862 he was private secretary to Governor William A. Buckingham. In 1859 he married Mary C. Robinson, a sister of the late Henry C. Robinson. His wife died in 1903, but four of their five children are still living. These are Reverend Frank R. Shipman, of Andover, Massachusetts; Arthur L. Shipman, the present corporation counsel of the city of Hartford; Mary D. Penrose, wife of Reverend Stephen B. L. Penrose, D.D., president of Whitman College, Washington; and Professor Henry R. Shipman, of Princeton University. The honorary degree of Doctor of Laws was conferred upon him by Yale University, in 1884.

In addition to his membership on the directorate of the Hartford Steam Boiler Inspection and Insurance Company (which has been noted above), Judge Shipman was a director of the *Ætna* Insurance Company, the Travelers' Insurance Company, the Phoenix Mutual Life Insurance Company, the Security Company, and the Collins Company. He was also a trustee of the Society for

Savings, a director and vice-president of the Retreat for the Insane, vice-president of the Wadsworth Atheneum, president of the Watkinson Library, vice-president of the American School at Hartford for the Deaf, a trustee of the Watkinson Juvenile Asylum and Farm School, and vice-president of the Missionary Society of Connecticut. He was deeply interested in religious life, and was a man of broad religious ideas. He was one of the founders of the ecclesiastical society now known as the Farmington Avenue Congregational Church, of Hartford, and was, in fact, the last survivor of those who signed its original "Articles of Association," in 1852. His interest in the church was deep and continuous, and he had held office in it for forty-five years.

Judge Shipman was a very social man, and an exceedingly pleasant companion with those fortunate enough to be counted among his intimate friends. His moral character was magnificent, and his devotion to the service of the public was almost equally remarkable. His judicial decisions constitute distinct and valuable additions to legal literature, and were uniformly inclined in favor of the equities of his cases, rather than towards the bare technicalities.

Judge Shipman's pleasant personality, and his valuable counsel, will be sadly missed. At a meeting of the board of directors of the Hartford Steam Boiler Inspection and Insurance company, held on June 29, formal notice was taken of the loss sustained by the board in his death, and a committee was appointed to draw up a testimonial which shall give appropriate expression to the esteem in which he was held by his colleagues.

EBEN SEARS.

On May 15, 1906, Eben Sears, who had long been connected with the Northeastern department of the Hartford Steam Boiler Inspection and Insurance Company, died at his home at Somerville, Massachusetts. Mr. Sears was born at Yarmouth, Massachusetts, December 8, 1849, and was the son of Captain Winthrop Sears, of the well-known Cape Cod family of that name. His great-grandfather, Eben Sears, was an officer in the Revolutionary War, and served as guard to Major André, the British spy, the night before his execution. In early life Mr. Sears followed the sea, as a marine engineer. On May 16, 1881, he entered the employment of the Hartford Steam Boiler Inspection and Insurance Company as an inspector in the Northeastern Department of the company (at Boston); and ten years later he was promoted to the position of director of inspectors in that department, a position which he held at the time of his death. His term of service with the company, though it covered twenty-five years, was not an eventful one in the usual sense of that expression, but it was distinguished by a continuous and faithful attention to the duties of the day, which won for him the unqualified respect and confidence of his employers.

On December 24, 1879, Mr. Sears married Miss Hannah Howes Davis, of Yarmouth, Massachusetts, who survives him. He also leaves three children, Miss Alice W. Sears, Miss Lucy D. Sears, and Mr. Winthrop Sears, now a student at Tufts College. Mr. Sears was of a genial, pleasant temperament, and socially was a delightful companion. He found his greatest happiness in his home life, and he was a devoted husband, and a kind and indulgent father. He had a genius, not only for making friends, but for holding them; and his passing will be deeply deplored by the many who had known him well, and had come to regard him with the affection of a brother.

DUNCAN COLQUHOUN.

On the very day of Mr. Sears' death, the Hartford Steam Boiler Inspection and Insurance Company lost another faithful and deeply respected employee, in the person of Duncan Colquhoun, who died, May 15, at his home in Buffalo, New York. Mr. Colquhoun was born in Glasgow, Scotland, December 7, 1837, and came to the United States with his parents in 1855, at the age of seventeen. After some seven years of hard work in the South and elsewhere, during which he labored in various capacities, he went to Buffalo, New York, where he became chief engineer in the Union Iron Works, a position in which he served with characteristic faithfulness for twenty years, until the works were closed. On December 27, 1882, Mr. Colquhoun entered the employ of the Hartford Steam Boiler Inspection and Insurance Company as inspector for Buffalo and vicinity; and for nearly a quarter of a century he has performed the duties of this office with eminent success and satisfaction to his company. In 1868 Mr. Colquhoun married Miss Mary Barrowman. His wife and three of his children passed away before him, but he leaves two daughters, Miss Agnes Colquhoun and Mrs. M. D. Ballard, both of Buffalo.

Mr. Colquhoun was among the charter members of the East Presbyterian church, of Buffalo, which was organized July 21, 1869, and he was the only person who had retained a continuous membership in the church from that time down to the present. He was faithful in all his relations with his fellow men, and was independent and self-reliant, though charitable towards the opinions of others. His unbending integrity was tempered by a warm heart and a cordial, helpful sympathy, which made his presence a stimulus to every good and manly impulse.

JOHN HENRY RANDALL.

John Henry Randall, who has been well known to the patrons of the Hartford Steam Boiler Inspection and Insurance Company in central and southern Connecticut for many years, died, on May 8, at his home in Bridgeport, Connecticut. Mr. Randall was born at Barnstead, New Hampshire, June 7, 1836, and learned his trade at locomotive building under his father, who was master mechanic in the Taunton Locomotive Works. At the age of eighteen or nineteen he became foreman in the shops of the Grover & Baker Sewing Machine Company, of Boston, Massachusetts, and later he became general superintendent of the "Little Wanzer" sewing machine factory, at Hamilton, Ontario. About this time (though we cannot give the exact dates) Mr. Randall had some experience as a locomotive engineer, running on the Indianapolis Central railroad, the Great Western railroad (between Buffalo, New York, and Montreal), and the Long Island railroad. In 1871 he went to Pittsburg, Pennsylvania, where he entered the employ of K. Britt & Sons, builders of oil drilling machinery, as superintendent. A panic in the oil business followed shortly afterwards, and in 1874 Mr. Randall returned to Boston, where he took charge, for about two years, of the first apartment house built in that city. He left this employment to take charge of the engineer's department of the Hollingsworth & Whitney Paper Bag Manufacturing Company, at Watertown, Massachusetts, subsequently becoming foreman in the shops of the Eastern railroad, at East Boston, where he remained until the fall of the year 1880, when poor health forced him to take a lengthy vacation. He did not return to the railroad shops, but in December, 1880, he en-

tered the Hartford office of the Hartford Steam Boiler Inspection and Insurance Company, as an inspector. In November, 1881, he was sent to Bridgeport, where for a time he was the only inspector in a district that included southwestern Connecticut and a portion of New York state. As the business of the company grew, and the inspection service necessarily increased, other men were added in his territory, and Mr. Randall was made chief inspector in the company's Southern Connecticut Department, with headquarters at Bridgeport; a position which he held at the time of his death.

In 1872 Mr. Randall married Mary Gaston, of Cambridge, Ohio, who is still living. Two children, Annette Randall Taylor and Henry Gaston Randall, likewise survive him, and also one grandchild, John Randall Taylor. He was a member of several secret societies, his membership in one of them having been continuously maintained for forty-six years.

Mr. Randall had a heart of gold. In business he was a man of unquestioned fidelity and integrity, and his private life was filled with kindly acts towards his fellows. His manner was at all times distinguished by a manly dignity, but underlying this there was an indescribably genial friendliness which endeared him to everyone.

The Abuse of Valves.

In a recent issue of the *Valve World*, published by the Crane Company, of Chicago, we find an article under the foregoing heading, which we commend to the perusal of all who have to do with the handling of valves. The substance of the article is reprinted below.

Many valves are returned to the manufacturers, after a term of service of uncertain length, by purchasers who claim that the valves are defective in workmanship, and not tight. The manufacturer is requested not only to credit the valves returned, but also to bear the expense of taking them out of pipe lines, and of putting the new ones in place. He is likewise expected to bear the cost of transportation both ways.

Undoubtedly there are cases in which valves defective in construction escape detection until they have been in service for a time; but in most cases the criticism that is directed to the manufacturer does not belong to him, and affects his reputation unjustly. When valves that are thus returned as defective have been received by the maker, and carefully examined and tested, it is found, in the great majority of cases, that the leakage was plainly due to the abuse and carelessness of the persons who installed them. It is an easy matter for a practical valve maker, or a good steam fitter, to determine when and how a valve has been abused; and if customers would take a little pains to examine leaky valves before returning them, they would find that in most cases the damage was done by their own men. It appears to us that any one who has done considerable steam fitting work should be able to determine for himself whether a valve has been abused or not, or should have somebody in his service who could do this, and be able to remedy the trouble without annoying the manufacturer with it.

Following are a number of reasons why valves leak after being placed in a pipe line:

1. We are confident that ninety per cent. of all the trouble with leaky valves arises from the improper use of cement, and from the failure to remove the

particles of cement, scale, chips, dirt, etc., that naturally get into the pipe while it is lying around a building, and lodge on the valve seat after steam is turned on. Cement should be applied on the male part only, for if placed on the female part it is apt to go through the pipe and get on the valve seat. In nearly all cases much more cement is used than is really necessary. If steam fitters would take pains to apply the cement as directed above, and would also make sure that

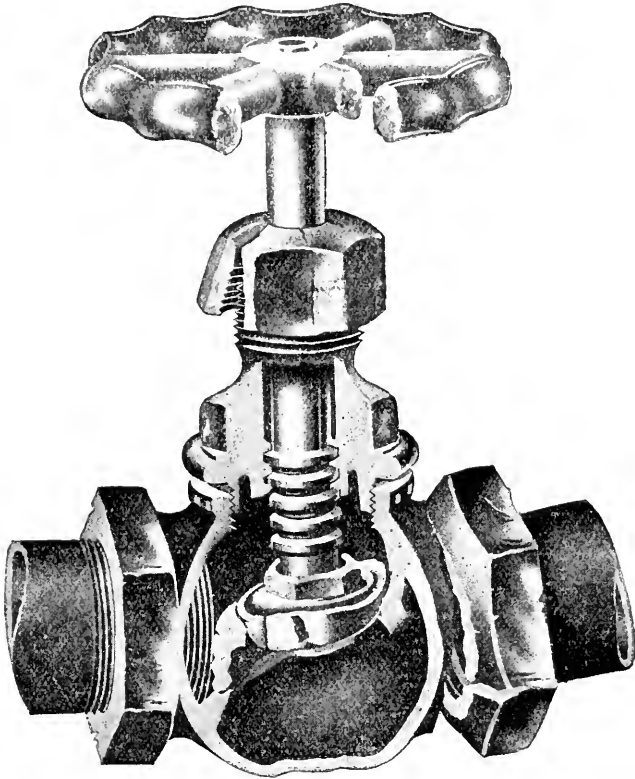

ILLUSTRATING VARIOUS ABUSES OF VALVES.

the pipe is clean by standing it on end and striking it a few times with a hammer before putting it into place, in order to loosen any scale or dirt that may be inside, an immense amount of trouble would be avoided. As a further precaution it is well, when a pipe line is first put into service, to open all the valves throughout the building, and blow steam through them thoroughly. After doing this properly there will be very little material in the pipes to cause trouble. When the line has been run for a short time, it would be well, as an additional precaution, to clean out all the valves thoroughly.

2. It often happens that threads on pipe are cut longer, or smaller in diameter, than standard; and, when this is the case, the pipe, upon being screwed into the valve, is likely to run up against the partition and injure it.

3. One of the common abuses is the application of a pipe wrench on the opposite end of the valve from the end which is being screwed on the pipe. This should never be done, particularly with the lighter class of valves, as it is almost certain to spring the valve, and hence cause it to leak.

4. If a light valve is put into a vice for the purpose of removing the centerpiece, the valve should certainly be clamped lengthwise. When removing the centerpiece care should be taken in all cases to have the disk some distance from the seat, as otherwise the disk will be forced down upon the seat, and some part of the valve will become strained. Never use an old strained monkey wrench on a centerpiece, as a wrench of this sort is quite likely to squeeze the corners of the centerpiece out of shape. If it is found impossible to remove the bonnet or centerpiece by ordinary methods, heat the *body* of the valve just outside of the thread with a blow-torch, or any other available means that can be applied to the body and not to the centerpiece. Then tap lightly all around the thread with a soft hammer. This method never fails, as the heat expands the body, and breaks the joint made by the litharge or cement.

5. When a stuffing box leaks, a steam fitter will often try to stop the leak by straining the stuffing box with a large wrench, when the real trouble is that the packing has become worn out and needs renewing.

6. It sometimes happens that when a valve is to be used on a header, the steam fitter will start out with a long piece of pipe that is unsupported, and, through carelessness, will allow the strain due to the weight of the pipe to come on the valve, thereby springing it.

7. In a pipe line where light valves are used, serious trouble is also likely to occur from the steam fitter not making proper allowance for expansion and contraction of the pipe system. The pipes and fittings are much more solid and rigid than the lighter brass valves, and the expansion strains will therefore relieve themselves upon the valves, unless this action is prevented by allowing for the expansion strains in other ways. A good example of this is afforded by most of the high buildings that are heated by steam, where it is difficult to take care of the expansion. The steam fitter will branch out of his riser with a feed pipe to a radiator. The radiator usually stands close to the riser, and the branch feed pipe supplying it is run underneath the radiator to the end remote from the riser, where it is commonly connected to the radiator valve by a short nipple. The cross piece, or branch feed, under the radiator, may be from three to six feet long, and is supposed to take up the expansion and contraction of the riser, which may amount to from half an inch to an inch and a half. The steam fitter does not appreciate the fact that the ordinary light angle radiator valve is the most flexible of all the connections, and will spring or distort itself before anything else in the branch. He makes his radiator valve serve as a swing joint and universal connection, and yet wonders why the valve leaks. In such buildings it is difficult to provide sufficiently for the expansion of the piping, and probably the safest way to ensure good work is to use valves of much heavier construction than usual, so that there will be no danger of their springing.

8. Frequently, when a valve leaks, somebody will undertake to tighten it by using some kind of a lever on the wheel. This should never be done, as it will in all probability injure the valve. The trouble in such cases is usually due to the presence of dirt in the valve, and it is much better to take the valve apart and clean the seat, than to try to force the dirt into the seat by the application of powerful leverage upon the stem.

The Properties of Steam.

FIRST PAPER.—REGNAULT'S EXPERIMENTS ON THE PRESSURE OF SATURATED STEAM.

The present article is the first of a series, in which we propose to give brief accounts of the experiments upon which our knowledge of the properties of steam is based, from the time of Regnault down to the present. It will be impossible to describe all the experiments in full, as that would require a book of generous proportions. The most important ones will be included, however, and at the close of the series a table will be presented, giving the chief properties of saturated steam, according to the best experimental information that we now have.

For the sake of brevity we shall commonly omit the word "saturated," in these papers, and the steam will everywhere be understood to be saturated, unless the contrary is explicitly stated.

Experiments upon the pressure of steam at various temperatures had been made, previously to Regnault's time, by many investigators, and Regnault, in the first volume of his memoirs, gives a list of such authorities, which may be consulted with advantage by those who are specially interested in the historical aspect of the subject. Among the best known of these early writers on the subject were Dalton, Watt, Bétancourt, Ure, Gay-Lussac, Arago, and Dulong. Special mention should also be made of Magnus, whose experiments were made almost simultaneously with those of Regnault. Magnus' experiments, so far as they extend, are in good agreement with Regnault's measures; but they were carried up to a pressure of only about ten pounds per square inch above the atmospheric pressure. The experiments made by the Franklin Institute committee must also be noted, although they now have only a historical interest. They extend up to about ten atmospheres, and are described in the *Journal* of the Franklin Institute for May, 1836, beginning with page 289.

When Regnault's experiments were published, all previous work along these lines became practically obsolete; for Regnault's resources were far greater than those of his predecessors, and Regnault himself was born with a genius for experimental work, which is rarely paralleled. A brief account of his life is given in the issue of *THE LOCOMOTIVE* for August, 1897, page 122, and a similar brief account of his famous memoirs on the physical properties of liquids, vapors, and gases will be found in *THE LOCOMOTIVE* for September, 1897, page 138.

Regnault performed an enormous amount of what may be described as preliminary, or preparatory, labor, in order that his subsequent work might be beyond reproach in every respect: and our knowledge of applied physics would be decidedly more satisfactory if some of his successors had imitated him more closely in so doing. He studied the general subject of thermometry in great detail, and compared his thermometers among themselves and with the air thermometer, with the greatest care, apparently taking nothing for granted. He even had his thermometers made in his own laboratory, if we may judge from the following passage on page 530 of the memoir on the pressure of saturated steam: "In order to make sure of the exactitude, and the perfect agreement among themselves, of the thermometers which have been employed in these various determinations, I have taken pains to have them constructed in my laboratory, from the Choisi-le-Roi crystal which has been used for all my instruments; and

they have been graduated and verified by our usual methods." His thermometry, as may be judged from this quotation, was of extraordinary accuracy for the time in which it was executed. It would be a poor compliment to the world of experimental science to suppose that no essential advance has been made in accurate thermometry during the sixty years that have elapsed since Regnault's work on steam pressure was completed: but the point to be observed is, that Regnault's work was done so well that there are comparatively few researches, even at the present day, in which the thermometry is superior to his. We have a far better knowledge of the mercury-in-glass thermometer than he had, but the labor and expense of applying all that we know are so great that experimenters too often slight their thermometry, to the consequent detriment of their results.

Regnault's experiments upon the pressure of saturated steam at various temperatures were published in 1847, in the first volume of what are commonly called his "Mémoires." The volume in question bears the title: "Rèlation des Expériences entreprises par ordre de Monsieur le Ministre des Travaux Publics, et sur la proposition de la Commission Centrale des Machines à Vapeur, pour déterminer les principales lois et les données numériques qui entrent dans le calcul des Machines à Vapeur." ("Account of Experiments undertaken by order of the Minister of Public Works, and at the suggestion of the Central Committee on Steam Engines, for determining the principal laws, and the numerical data, which enter into computations relating to the Steam Engine.") This volume (as is told more fully in THE LOCOMOTIVE for September, 1897.) contains ten memoirs, the one in which we are at present interested being the eighth. Its title is: "Des Forces élastiques de la Vapeur d'Eau aux différentes Températures." ("On the Elastic Force of the Vapor of Water, at different Temperatures.") This memoir was read at the French Academy of Sciences on December 15, 1845; but the first part of it, giving the vapor pressure over ice, and that over water from the freezing point up to about 60° C. (140° Fahr.), had been previously published in 1844, in the *Annales de Chimie et de Physique*, series 3, volume 11, page 273.

The memoir here cited contains substantially all that Regnault did towards determining the pressure of steam, but there are passages in certain of his other memoirs which have a more or less important bearing upon the subject. Thus the second memoir in the second volume of the "*Rèlation des Expériences, etc.*," which was read before the French Academy of Sciences on August 14, 1854, and published in its present form in 1862, is devoted to the experimental determination of the pressure of the saturated vapors of liquids other than water. On page 340 of this memoir there is a statement concerning the methods of experiment which appears to be of sufficient general importance to be given in full in the present place. A translation is therefore appended: "The methods that I have followed in determining the elastic forces of vapors over a large range of temperature are similar to those which I have applied to the vapor of water, and which were explained in my first memoir. [I. e., the eighth memoir of the first volume.] They are of two kinds. In the first method, I determine, directly, the elastic force that a vapor exerts, at different temperatures, in a vacuum; and in the second I observe the temperature of the vapor when the liquid is boiling, subject to the pressure of an artificial atmosphere. [These two methods will be further explained below, in connection with the experiments upon water.] The first method is followed for low temperatures; the second is specially employed

for high temperatures. In every case I have tried to extend, as far as possible, the determinations by each of the two methods, in order that the two sets of experimental results may overlap each other sufficiently to enable one to judge, readily, of their agreement. I have already shown in my memoir on the pressure of saturated steam, that the coincidence is perfect in the case of water; the two methods giving identical results, at the same temperatures. I shall show that the same is true of other volatile liquids, provided they are perfectly pure. But when a liquid contains a portion, even though it be extremely small, of another volatile substance, the two methods give different values for the elastic force of the vapor at the same temperature; and hence the agreement affords an extremely delicate test for judging of the homogeneity of the volatile substance. Theoretically, the two methods are essentially different; for in the first the vapor is at rest, so long as the temperature is uniform and constant, while in the second, on the contrary, the vapor is continually in motion, the liquid continually giving off fresh volumes of vapor, which displace that previously formed. In order to take note of this difference, I propose to call the first the *static method*, and the second the *dynamic method*."

These two methods called by Regnault, and by other experimenters since his time, the *static* and *dynamic* methods, respectively, are both in use at the present day, and there has been considerable discussion as to whether they do or do not yield absolutely identical results, when applied to an absolutely pure liquid. We shall return to this question in a later article. It is here mainly important to point out that Regnault used both methods, that he was keenly alive to the possibility of their non-agreement, and that he caused his experiments, as made by the two methods, to overlap by an amount which was sufficient, in his judgment, to show that the agreement was sensibly perfect, to the order of accuracy of his own work.

We proceed to describe the apparatus used by Regnault in carrying out his experiments upon water vapor by the "static" method. He made a number of series of measurements by this method, and, like the good experimenter that he was, he varied his apparatus somewhat, from one series to another, in order to facilitate the detection of any unforeseen source of error, or any source whose importance had been under-estimated. We shall not attempt to describe all the minor modifications that were introduced, for it will be sufficient for our purpose to describe one of the forms; and we shall select the arrangement that was adopted in making the experiments that he designates as "Series *a* and *b*," in Table No. II, and "Series *c*" in Table No. III.

The apparatus used is shown in Fig. 1. It is similar in principle to that previously used by Dalton, though Regnault's form is much superior to Dalton's. The principle underlying it may be stated thus: Let there be two barometric tubes, placed side by side so that the mercury may have the same temperature in each, and each dipping at the bottom, into the same vessel of mercury. If the vacua in the upper parts of these tubes are both perfect, then the two columns of mercury will stand at precisely the same height. If, now, a small quantity of water be introduced into one of the vacuous spaces, it will partially evaporate, the evaporation ceasing when the space containing the water becomes filled with vapor of the particular density corresponding to the temperature to which the barometric column is exposed. The mercury column in the tube containing the water will meanwhile fall by an amount which, roughly speaking, corresponds to

the pressure of the water vapor, at the given temperature. In practice, certain corrections have to be applied to the observed difference in the barometric reading. For example, in order that we may be sure that the vapor present is really

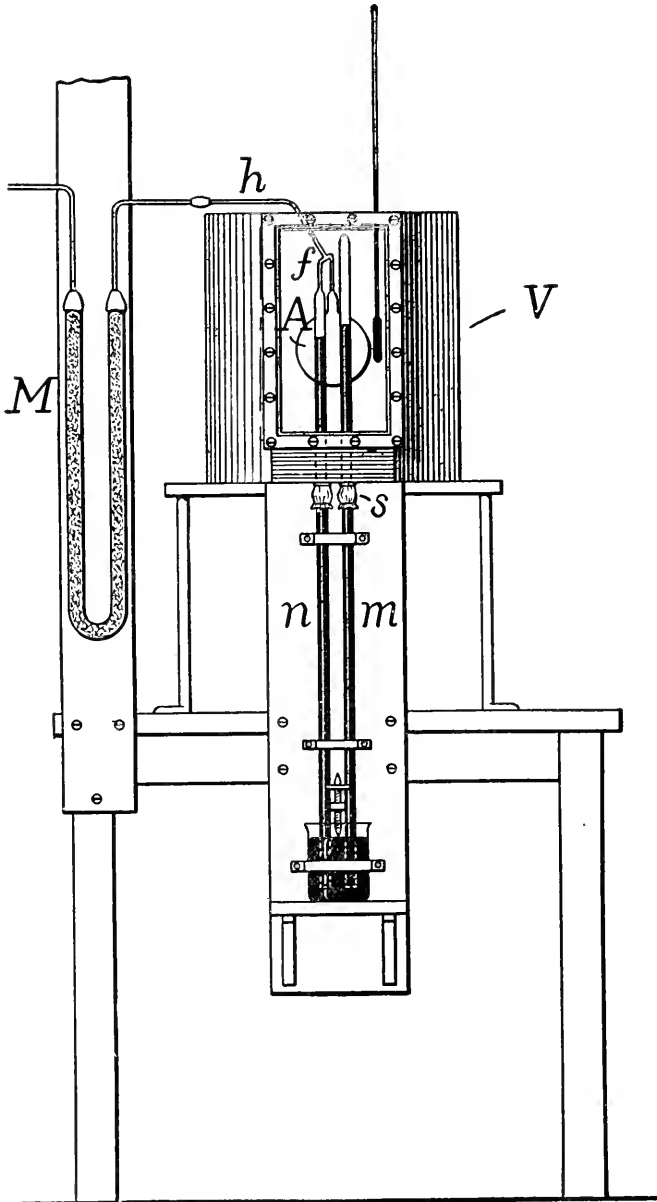

FIG. 1. — REGNAULT'S APPARATUS FOR LOW PRESSURES.

saturated, it is necessary to introduce a slight excess of water, over and above that which would be sufficient to just saturate the space in the barometer; and if this excess remains in contact with the top of the mercury column, we shall have to make allowance for the amount by which the column is depressed by the weight of the unevaporated water. The "surface tension" of the mercury, which causes the top of the column to assume the familiar rounded shape, is also likely to be modified by the presence of the water, and the water itself has a surface tension which acts in the opposite direction to that of the mercury, and allowance has to be made for this fact. Regnault investigated all these sources of error, and either satisfied himself that they are of no practical importance, or else determined the magnitude of the errors that they introduce, and made proper allowances. In some of his experiments Regnault followed this identical plan, while in others he prevented the water from coming into actual contact with the mercury in the barometric column, by placing it in a separate vessel or chamber, with which the barometric tube was in free communication.

The actual form of apparatus that we shall describe consisted, as will be seen from Fig. 1, of a pair of barometric tubes of equal diameter, dipping, at the bottom, into the same vessel of mercury. One of these tubes, *m*, was closed at the top, just like any ordinary barometer tube; but the other one, *n*, was connected by means of a fine tube, *f*, with a hollow glass sphere, *A*, having a diameter of about four inches. A branch tube, *h*, led from *f* (and therefore from *A*) to an air pump, through the U-tube *M*, which was filled with fragments of pumice stone moistened with concentrated sulphuric acid. The glass globe, *A*, and the upper portions of the barometer tubes, *m* and *n*, were enclosed in a cylindrical sheet-iron vessel, *I'*, having a capacity of about 12 U. S. gallons, and provided with a plate glass window through which the upper ends of the mercury columns could be seen. The openings through which the tubes *m* and *n* pass, in the bottom of the vessel *I'*, were made water-tight by tying short lengths of flexible tubing around the tubes, and around small projecting collars upon the bottom of *I'*, as indicated at *s*. The appliance shown between the barometer tubes at the bottom served to facilitate the observation of the level of the mercury in the cistern. It consisted of a short metal rod, pointed at the ends and threaded. The lower pointed end of the rod being brought into contact with the mercury, and the length of the rod being known, the level of the mercury in the cistern is easily obtained by noting the position of the upper end of the rod. This indirect procedure was adopted because it was found to be more convenient and accurate than attempting to determine the exact level of the mercury by observation directly through the sides of the glass cistern. The effects of refraction upon observations of the upper ends of the mercury columns made through the glass window and the contents of the vessel *I'*, were investigated by Regnault, and allowance was made for such errors as were found to be of importance.

During the experiments that were made at temperatures above the freezing point, the vessel *I'* was filled with water, which was stirred continuously; the temperature of the water being known by means of a mercury thermometer, as indicated in the figure. In the apparatus employed by Dalton, the barometric tubes were both surrounded by water over their entire length; but Regnault preferred to use the apparatus as shown, because he found that if the tank were longer, the water within it settled into layers of different temperatures, immediately upon ceasing the stirring; while if the stirring was continued, it was

impossible to avoid oscillation of the mercury columns in the barometric tubes. He assured himself, however, by direct experiments, that the conduction of heat upward or downward by the mercury columns did not introduce any sensible error, within the temperature limits for which he used the apparatus.

In performing an experiment, the procedure was as follows: A little glass capsule, entirely filled with recently boiled water, and sealed up tight, was first introduced into the glass globe, *A*. The air pump was then set in operation, and the glass globe was exhausted as perfectly as possible. Air was then allowed to flow back into the globe, until the original atmospheric pressure within it was again restored. It will be observed that the air in the globe, in passing to the air pump, must traverse the U-tube *M*; and the air which returned to the glass globe must again traverse the U-tube, though in the opposite direction. Concentrated sulphuric acid has a powerful affinity for water, whether in the liquid form or in the form of vapor; and the object of the U-tube was to effect the absorption of such moisture as might be contained in the air entering the globe. The operation of exhausting and refilling the globe with air was repeated some 40 or 50 times, and finally a vacuum as perfect as the pump could produce was made, and the small tube leading to the air-pump was then sealed off by a blowpipe at *h*. The small quantity of air still remaining in the glass globe and the barometric tube *n* was then assumed to be perfectly dry. The next step was to surround the globe with ice and water, so as to cool the residual air to the melting point of ice. After the apparatus had remained at rest for some time, until the desired temperature was presumably attained, the heights of the mercury columns in the two barometric tubes were read off, and the difference between the two gave the pressure of the residual air in the globe, at the temperature of melting ice. From this the pressure at any other temperature could be determined, in the usual manner.

The ice was next taken away from the globe, and the globe was heated until the little capsule of water that it contained was broken open by the expansion of its own contents. The water thus liberated in the globe evaporated until the space within the globe and the barometric tube attached to it were saturated with water vapor; the unevaporated excess remaining in the globe. The tank *V* being then filled with water at a known temperature, Regnault had only to read the two mercury columns to know the pressure within the globe at the temperature of the water in *V*. This pressure, corrected for the pressure of the residual air that the pump did not remove, gave the pressure of the water vapor due to the temperature prevailing at the time in the water of the tank *V*.

By means of this apparatus, or of some slight modification of it, Regnault determined the vapor pressure of water at temperatures ranging from 0° C. up to about 60° C. (i. e., from 32° Fahr. up to about 140° Fahr.). To determine the vapor pressure of ice, he replaced the sheet-iron vessel, *V*, by a smaller vessel of glass, which he filled with a freezing mixture. The water in the globe then froze, and the barometric readings (which were made just as before) gave the vapor pressure due to evaporation from the solid ice. The experiments upon ice were carried down to temperatures as low as 32.8° below zero, Centigrade (or 27° below zero, Fahrenheit). Regnault was of the opinion that the vapor-pressure curve of ice is merely a prolongation of the corresponding curve of water. In this he was mistaken, though he examined the question with much care, and his observations appeared to warrant his conclusion. Further consideration will be given to this subject in a subsequent article.

The apparatus shown in Fig. 1, although quite satisfactory for low temperatures where the pressure was only a small fraction of an atmosphere, was altogether inapplicable to higher temperatures. Regnault therefore constructed and used apparatus of a very different type for his work at these higher temperatures and pressures. The general idea embodied in the new form is thus stated by the experimenter himself (*Rélation des Expériences*, etc., Vol. 1, page 514): "It is easy to . . . arrange the experiment so that the observation shall be precisely identical with those in which water is boiled at the ordinary pressure of the atmosphere, in determining the position of the 100°-point [the 212°-point on the Fahrenheit scale] of thermometers; and the temperature at which water boils at various pressures can then be determined with the same degree of precision. It is sufficient for this purpose, to make the water boil in a vessel which communicates freely with a rather large space which can be filled with air that is compressed or rarefied to any desired degree. This air constitutes an 'artificial atmosphere,' which exerts a pressure at the surface of the heated liquid. In this manner it is possible to obtain a boiling point that is just as stationary as that of water exposed to the free air, and, moreover, this temperature can be kept stationary for as long a time as is desired."

For the higher temperatures that he investigated (involving pressures running up to nearly 28 atmospheres, absolute,) Regnault used an apparatus that was massive and strong enough to be free from danger of explosion; and he calls this the "large apparatus." However, he says (page 515), "before constructing an apparatus which would permit me to push the experiments to the very highest pressures, and which would involve considerable expense, I thought that it would be convenient to try the plan on a smaller scale, for the purpose of studying it under varying conditions, and detecting such sources of error as it might involve." He therefore first built and used what he calls his "small apparatus," with which he experimented at pressures ranging from one-twelfth of an atmosphere up to about $4\frac{1}{2}$ atmospheres, absolute. We shall describe the "small apparatus" only, as the larger one was built upon precisely the same principles, the modifications being only such as appeared to be desirable in dealing with heavier pressures, except for the addition of an air thermometer, as will presently be noted.

The "small apparatus" is shown diagrammatically, in Fig. 2. The water to be studied was placed in an air-tight copper boiler, *A*, to whose construction and interior arrangement we shall return in a moment. Heat being applied to the boiler, the water within it was caused to boil, and the steam thus produced passed out at the top, into a tube or pipe, *P*, that passed obliquely upward to a hollow copper sphere, *B*, some 14 inches in diameter. The copper sphere was filled with air at a known pressure by means of the small tube *t*, which communicated with an air pump; an exhaustion pump being used for pressures below one atmosphere, and a pressure pump for higher pressures. The inclined pipe, *P*, was surrounded, for a considerable part of its length, by a condensing jacket, *C*, and cold water was kept continuously circulating through the space between *P* and *C*. When the apparatus was in action, the steam which was produced in the boiler, *A*, rose into the pipe, *P*, where it was condensed by the chilling action of the water-jacket, *C*, so that it ran back into the boiler again in the form of water. By varying the pressure of the air in the copper sphere, *B*, the boiling point of the water in *A* could be observed at any desired pressure within the

limit of strength of the apparatus. To secure greater uniformity of temperature the copper sphere, *B*, was surrounded by a water bath, contained in a zinc vessel, as indicated in the diagram.

The cover of the copper boiler, *A*, was held in position by bolts, and was pierced by four thin iron tubes, of which only two (*a* and *b*) can be seen in the diagram. These tubes, which were closed at the bottom and open at the top, were partially filled with mercury, and each held a delicate thermometer. Two of the thermometer bulbs were situated well below the surface of the water, and the other two came down to within a short distance of the water, but were entirely surrounded by steam. (Regnault, throughout his experiments, took care

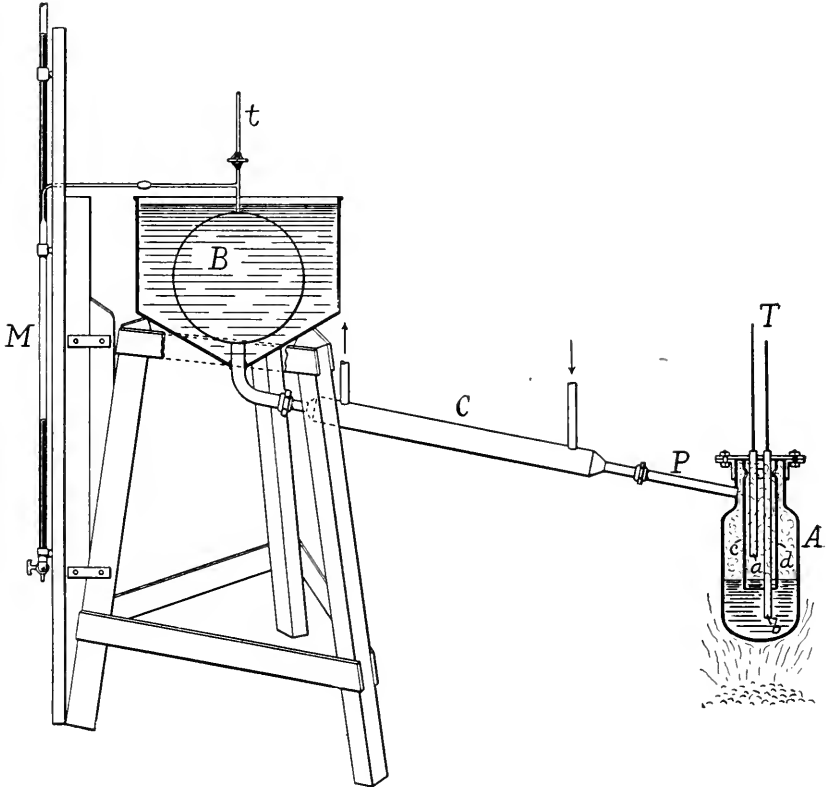

FIG. 2. — REGNAULT'S "SMALL APPARATUS" FOR HIGHER PRESSURES.

to ascertain that the water had essentially the same temperature as the steam space immediately above it. The wisdom of this precaution is abundantly evident from the writings of subsequent authorities. See, for example, an article by H. A. Hazen, entitled, "Pressure of the Vapor of Water," in *Science* for February 16, 1894, page 87.)

The cover of the boiler, *A*, also carried a large tube of thin sheet copper, *c*, *d*, which extended down below the surface of the water, and was provided, at the top, with openings which served to place its interior in free communication with

the rest of the steam space of the boiler. The object of this copper tube, or mantle, was to shield the thermometer tubes and protect them against possible radiation of heat to the sides of the boiler, which were presumably slightly cooler than the central portions of the vapor.

It was found that this form of apparatus was capable of yielding results that are extraordinarily consistent, and presumably correspondingly accurate. The pressure in *B* being adjusted, approximately, to any desired value, the water in *A* was caused to boil, and after steady ebullition had proceeded for some time, the thermometers, *T*, were read, and the corresponding pressure was determined accurately, by a simultaneous reading of the mercury pressure gauge, *M*, shown on the left. It will not be necessary to describe this gauge further than to state that it was, in effect, a U-tube, provided with a stop-cock at the bottom, by which mercury could be withdrawn from the tube at pleasure. (The U-tube is seen edgewise in the illustration.)

In Regnault's "large apparatus," to which reference has been made above, the only essential change consisted in the arrangement of the thermometers in the copper boiler, *A*, and in the arrangement of the mercury gauge used for measuring the pressures. Three thin pendant tubes were secured to the cover of *A*, two of which contained mercury thermometers, as before, while the third, which was of considerably larger diameter, received the bulb of an air thermometer. One of the mercury thermometers extended below the surface of the water, and the other was suspended with its bulb near the surface of the water, but above it. The bulb of the air thermometer was made of very thin glass, and was situated entirely within the steam space. It had the form of a cylinder with rounded ends, and was 12 inches long, and nearly $1\frac{1}{4}$ inches in diameter. In view of the fact that a slight variation of temperature corresponds to a considerable change in pressure when the pressure is large, and that Regnault's knowledge of the properties of mercury thermometers was necessarily inferior to the knowledge that we have today, it must be regarded as a fortunate circumstance that he took the precaution to observe the temperatures by the air thermometer directly, at high pressures; the uncertainties of the mercury thermometer being thereby eliminated entirely, in the region where those uncertainties were of considerable moment.

The experiments at high pressures with the "large apparatus" were carried out at the Collège de France, Paris, in a special building erected to enable the physicist Savart to carry out certain experiments in hydraulics. Owing to the death of Savart the building was never put to the use for which it was intended, but it proved an excellent place for Regnault's purposes. It consisted of a square, two-storied tower, solidly built of cut stone. This tower was 12.5 meters (41 feet) high, and Regnault's mercury gauge was attached securely to one of its walls. A gauge of this height would be long enough to indicate pressures up to something like 16 atmospheres, absolute. Regnault desired to carry his measures to pressures considerably greater than this, and in order that he might be able to observe higher pressures on his mercury gauge directly, he erected a stout wooden framework on top of the stone tower, thereby extending his mercury column upward until it had a total height of approximately 24 meters (78 feet), which would correspond to a limiting maximum pressure of something like 31 atmospheres, absolute. Readings of this mercury gauge were taken at the top and bottom, simultaneously, by two observers who were trained

to the work. Thermometers were arranged along the side of the mercury column, so that its temperature could be ascertained at every point, and its readings reduced to what they would have been if the temperature of the mercury in the column had always been 0° C. (32° Fahr.) at all points. (A full description of this mercury gauge is given in Regnault's sixth memoir, on the law of the compressibility of elastic fluids.)

To reprint even the results of all Regnault's measurements of steam pressure would require a great deal of space, and for full data in this respect, reference must be made to the original memoir. Moreover, we shall not make use of all of his work, even in the preparation of the tables with which this present series of articles will terminate. Excellent as Regnault's work was, we have, today, results that are apparently still better, over a part of the range that he covered; and we shall make use of these more recent experiments where it appears desirable to do so.

For convenience of reference, we append a table showing the number of different series of measurements that he made, the number of separate experiments in each, and certain other data that may be serviceable for purposes of reference.

OUTLINE OF REGNAULT'S EXPERIMENTS ON THE PRESSURE OF STEAM.

No. of table and series • (Regnault's designation).	Approximate range of temperature (Centigrade).	Number of experiments in series.	Designation of thermometers used for temperature of vapor.	Remarks.
<i>I.</i>	4° to 58° .	63	No. 7.	Static method. Fig. 1.
<i>II. a.</i>	0° " 50° .	28	Nos. 7 and 8.	" " "
<i>II. b.</i>	0° " 42° .	52	Nos. 7 and 8.	" " "
<i>III. c.</i>	0° " 38° .	52	No. 7.	" " "
<i>III. d.</i>	0° " 20° .	25	No. 7.	" " "
<i>III. e.</i>	0° " 23° .	38	No. 7.	" " "
<i>III. f.</i>	-30° " 0° .	14	No. 7.	" " "
<i>III. g.</i>	-28° " 0° .	24	Nos. 2 and <i>M.</i>	" " "
<i>III. h.</i>	-33° " $+100^{\circ}$	55	Nos. 2, 7, and <i>A.</i>	" " "
<i>III. i.</i>	0° only.	10	" " "
<i>III. j.</i>	0° to 16°	19	No. 7.	" " "
<i>III. k.</i>	0° " 16° .	16	No. 7.	" " "
<i>III. l.</i>	0° " 44° .	43	No. 7.	" " "
<i>III. m.</i>	0° " 58° .	31	No. 7.	" " "
<i>IV. n.</i>	43° " 100° .	61	Nos. 7 and 8.	Dynamic method. Small
<i>IV. o.</i>	48° " 100° .	47	Nos. 7 and 8.	" " apparatus.
<i>IV. p.</i>	47° " 100° .	17	Nos. 7 and 8.	" " "
<i>IV. q.</i>	91° " 100° .	25	No. 7 and 8.	" " "
<i>V. r.</i>	100° " 147° .	31	Nos. 0 and 11.	" " "
<i>V. s.</i>	100° " 128° .	16	Nos. 0 and 11.	" " "
<i>V. t.</i>	121° " 145° .	47	Nos. 2 and 11.	" " "
<i>u.</i>	100° " 150° .	24	Nos. 0 and 10.	Dynamic method. Large
<i>v.</i>	100° " 161° .	32	Nos. 0 and 10.	" " apparatus.
<i>w.</i>	100° " 172° .	21	No. 0.	" " "
<i>x.</i>	100° " 165° .	21	0, 10, and air.	" " "
<i>y.</i>	100° " 219° .	53	0, 10, and air.	" " "
<i>z.</i>	100° " 232° .	81	0, 10, and air	" " "
Total number of experiments—937				

Hartford Steam Boiler Inspection and Insurance Company.

ABSTRACT OF STATEMENT, JANUARY 1, 1906.

Capital Stock, \$500,000.00.

ASSETS.

	Par Value.	Market Value.
Cash in office and in Bank,		\$137,832.23
Premiums in course of collection (since Oct. 1, 1905),		201,827.69
Interest accrued on Mortgage Loans,		24,082.58
Loaned on Bond and Mortgage,		952,645.00
Real Estate,		14,690.00
State of Massachusetts Bonds,	\$100,000.00	96,000.00
County, City, and Town Bonds,	368,500.00	383,880.00
Board of Education and School District Bonds,	46,500.00	48,300.00
Drainage and Irrigation Bonds,	5,000.00	5,000.00
Railroad Bonds,	1,231,000.00	1,305,000.00
Street Railway Bonds,	60,000.00	59,150.00
Miscellaneous Bonds,	65,500.00	67,305.00
National Bank Stocks,	41,800.00	57,600.00
Railroad Stocks,	177,800.00	240,900.00
Miscellaneous Stocks,	35,500.00	33,925.00
	\$2,131,600.00	
Total Assets,		\$3,688,146.50

LIABILITIES.

Re-insurance Reserve,		\$1,851,706.33
Losses unadjusted,		34,614.94
Commissions and brokerage,		40,365.54
Surplus,	\$1,261,459.69	
Capital Stock,	500,000.00	
Surplus as regards Policy-holders,	\$1,761,459.69	1,761,459.69
Total Liabilities,		\$3,688,146.50

On December 31, 1905, the HARTFORD STEAM BOILER INSPECTION AND INSURANCE COMPANY had 92,038 steam boilers under insurance.

L. B. BRAINERD, Pres. and Treas. FRANCIS B. ALLEN, Vice-President.
 J. B. PIERCE, Secretary. L. F. MIDDLEBROOK, Asst. Sec'y.
 C. S. BLAKE, Supervising General Agent.
 E. J. MURPHY, M. E., Consulting Engineer.
 F. M. FITCH, Auditor.

BOARD OF DIRECTORS.

FRANK W. CHENEY, Treas. Cheney Brothers Silk Manufacturing Co.	LUCIUS F. ROBINSON, Attorney, Hartford, Conn.
CHARLES M. BEACH, of Beach & Co.	JOHN O. ENDERS, U. S. Bank, Hartford, Conn.
GEORGE BURNHAM, Baldwin Locomotive Wks., Philadelphia.	LYMAN B. BRAINERD, President and Treasurer, Hartford Steam Boiler Inspection and Insurance Co.
C. C. KIMBALL, President Smyth Manufacturing Co., Hartford, Conn.	MORGAN B. BRAINARD, Asst. Treasurer Etna Life Insurance Co.
PHILIP CORBIN, P. & F. Corbin, New Britain, Ct.	F. B. ALLEN, Vice-Prest. Hartford Steam Boiler Inspection and Insurance Co.
GEORGE A. FAIRFIELD, Pres. Hartford Machine Screw Co.	CHARLES P. COOLEY, Treas. The Fidelity Company, Hartford, Conn.
J. B. PIERCE, Secretary Hartford Steam Boiler Inspection and Insurance Co.	
ATWOOD COLLINS, Prest. Security Co., Hartford, Conn.	

Incorporated
1866.



Charter Per-
petual.

The Hartford Steam Boiler Inspection and Insurance Company

ISSUES POLICIES OF INSURANCE COVERING

ALL LOSS OF PROPERTY

AS WELL AS DAMAGE RESULTING FROM

LOSS OF LIFE AND PERSONAL INJURIES DUE TO STEAM BOILER EXPLOSIONS.

Full information concerning the Company's Operations can be obtained at any of its Agencies.

Department.	Representatives.	Offices.
NEW YORK, . . .	C. C. GARDINER, JR., Manager, R. K. McMURRAY, Chief Inspector,	New York City, N. Y., 100 William St.
NORTHEASTERN, . . .	C. E. ROBERTS, Manager, F. S. ALLEN, Chief Inspector,	Boston, Mass., 101 Milk St. Providence, R. I., 29 Weybosset St.
PENNSYLVANIA, . . .	CORBIN & GOODRICH, Gen. Agents, WM. J. FARRAN, Chief Inspector,	Philadelphia, Pa., 432 Walnut St.
MARYLAND, . . .	LAWFORD & McKIM, Gen. Agents, R. E. MUNRO, Chief Inspector,	Baltimore, Md., 13-14-15 Abell Bldg. Washington, D. C., 511 Eleventh St., N. W.
SOUTHEASTERN, . . .	W. S. HASTIE & SON, Gen. Agts., W. M. FRANCIS, Chief Inspector,	Charleston, S. C., 44 Broad St.
SOUTHERN, . . .	LOUIS V. CLARK & Co., Gen. Agents, H. E. STRINGFELLOW, Chief Inspector,	Birmingham, Ala., 214-216 N. 20th St.
GULF, . . .	PETER F. PESCU, General Agent, R. T. BURWELL, Chief Inspector,	New Orleans, La., 818 Gravier St.
HOME, . . .	E. H. WARNER, General Agent, H. C. LONG, Special Agent, F. H. WILLIAMS, JR., Special Agent, F. S. ALLEN, Chief Inspector,	Hartford, Conn., 650 Main St.
SOUTHERN CONN., . . .	W. G. LINEBURGH & SON, Gen. Agts.,	Bridgeport, Conn., 1 Sanford Building.
PITTSBURG, . . .	JAMES W. ARROTT, LTD., Gen. Agt., BENJAMIN FORD, Chief Inspector,	Pittsburg, Pa., 401 Wood Street.
NORTHERN OHIO, . . .	C. A. BURWELL, General Agent, H. A. BAUMHART, Chief Inspector,	Cleveland, Ohio, 337 W. Superior Ave., N. W.
NORTHWESTERN, . . .	H. M. LEMON, Manager, JAMES L. FOORD, Chief Inspector,	Chicago, Ill., 169 Jackson St.
SOUTHWESTERN, . . .	VICTOR HUGO, Manager, VICTOR HUGO, Chief Inspector,	St. Louis, Mo., 319 North Fourth St.
WESTERN, . . .	THOS. F. DALY, General Agent, T. E. SHEARS, Chief Inspector,	Denver, Col., 210-215 Ta- bor Opera House Bldg.
PACIFIC COAST, . . .	MANN & WILSON, General Agents, J. B. WARNER, Chief Inspector,	Oakland, Cal., 464 Tenth st.

The Locomotive

PUBLISHED BY THE HARTFORD STEAM BOILER INSPECTION AND INSURANCE COMPANY.

VOL. XXVI.

HARTFORD, CONN., OCTOBER, 1906.

No. 4.

Concerning Blowoff Tanks.

The blowoff pipes of steam boilers usually discharge directly into the open air; but it is not always permissible to dispose of the contents of the boilers in this simple fashion, and in many cases special tanks to receive the discharge have to be provided. This is especially true in cities, where the waste finds its way, ultimately, into the sewers. It is injurious to a sewer to blow the contents of

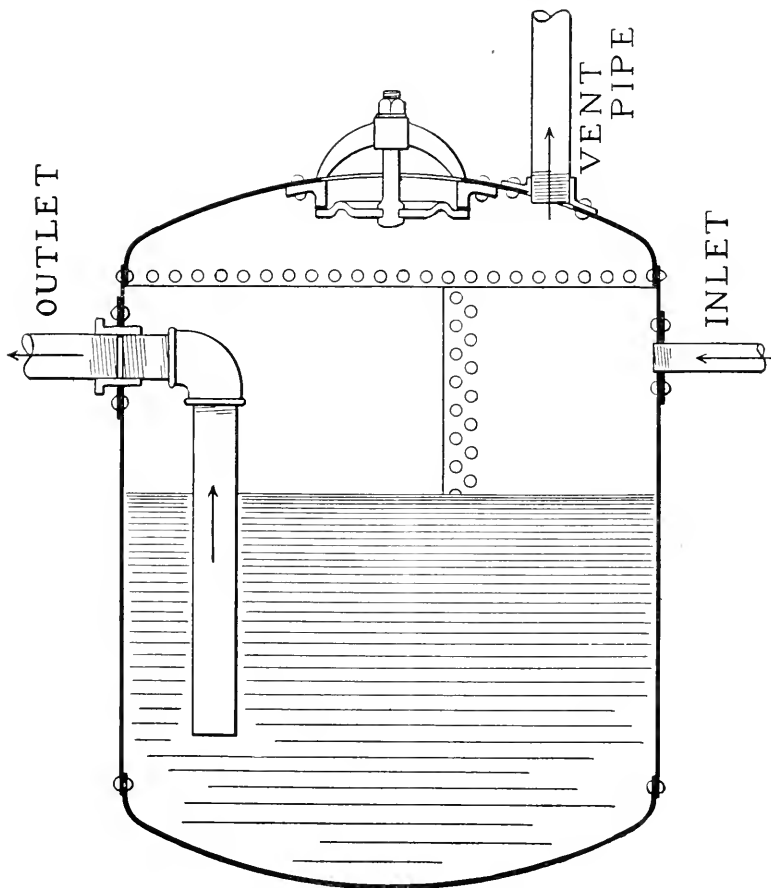

FIG. 1.—A CORRECT FORM OF BLOWOFF TANK.

a boiler into it directly, and many cities have ordinances requiring that an intermediate receptacle of some sort shall be provided, in order that the sewer may be protected from the destructive action of the direct discharge. It is objectionable, also, to fill the sewer with hot steam; and when tanks are provided they should be so constructed that they will permit the steam and water to separate, the steam being allowed to escape into the air through a vent pipe at some point where it will not constitute a nuisance, while the water is either permitted to flow from the tank into the sewer under the combined influence of gravity and such pressure as may exist within the tank, or pumped out of the tank when the conditions are such that the assistance of a pump is required.

When blowoff tanks are employed, it is exceedingly important that they should be made strong enough to withstand a considerable pressure. Too often they are regarded in the light of mere vessels which are to receive the contents of the boiler without being themselves subjected to any serious pressure. This is, indeed, the ideal function of a blowoff tank; and yet in designing such a tank we should always bear in mind the possibility of its being subjected to a pressure of some magnitude, through the occurrence of conditions that were perhaps not foreseen when the plant was installed. The neglect of this precaution has resulted in many serious accidents, often accompanied by loss of life.

A correct form of construction for a blowoff tank is shown in Fig. 1. This tank is built of steel, the sides being $\frac{3}{8}$ in. thick, and the heads $\frac{1}{2}$ in. The shell is double riveted, and the heads are bumped to a radius equal to the diameter of the shell. The blowoff pipe enters at the side, near the upper head, the opening for it being re-enforced by riveting to the shell a piece of plate $\frac{1}{2}$ in. or more in thickness. The water that is discharged into the tank passes out again through a siphon which comes down to within six inches or so of the bottom of the tank, and is designated, in Fig. 1, as the "outlet." The siphon is made of pipe 3 in. or 4 in. in diameter (the diameter of the blowoff being assumed to be 2 in.), in order that the water may have the freest means of escape. The elbow in the siphon is secured to a short nipple, which enters a bushing that is screwed into a re-enforced opening in the shell. Another piece of pipe, of diameter equal to that of the internal part of the siphon, enters the bushing on the outside, and leads to the sewer. A vent pipe, preferably 4 in. in diameter, at least, enters the upper head through a pressed steel flange, the collar of which is of sufficient length to afford a proper holding power to the threads on the end of the pipe. Finally, a manhole is provided, so that the interior of the tank may be readily accessible for inspection and repairs, and for the removal of such deposits as may accumulate in it.

In the engraving, we have shown the blowoff pipe as discharging directly against the siphon. This was done in order that we might show both the siphon and the blowoff distinctly. There is no serious objection to placing the two pipes in this manner, if the siphon is solidly constructed, so that it cannot be loosened nor displaced by the impact of the water from the blowoff. It is preferable, however, to have the blowoff and the outlet pipe enter the tank at right angles to each other.

We do not insist upon blowoff tanks having the particular design shown in Fig. 1, but we do insist upon their having a strength amply sufficient to enable them to resist any pressure to which they may be exposed. The size and shape of the tank, and the sizes of its outlet and vent pipes, will naturally vary from

one steam plant to another, the number of boilers in the battery, and the capacity of each, having a considerable influence upon these elements. Blowoff tanks are often placed underground, but we greatly prefer to have the tanks and their pipes so situated that they can be easily examined at all times.

As regards the intensity of the pressure that may exist in a blowoff tank, we can hardly say more than that it depends upon the sizes and lengths of the pipes, upon the size of the tank, upon the number and capacity of the boilers that may be blown off at the same time, upon the working pressure that is carried in the boilers, and upon various other circumstances. In a tank that is well designed, and adapted to the work that it has to do, the usual pressure, while blowing off, may be from 10 to 20 lbs. per square inch, though it should be understood that this estimate is given merely for the information of those who have had no experience with such tanks, and that it does not pretend to represent the facts of general practice except in the very roughest way.

A boiler should never be blown off into a tank that is already full of water, or nearly so; for it is easy to understand that the violent discharge of more water into such a tank is certain to produce a very considerable pressure, especially in the first few moments, before the flow out through the exit pipe has become fully established. It is hard to say how great a pressure might thus be produced, but if the blowoff were suddenly thrown wide open, so that the discharge due to the full diameter of the pipe could be turned instantly into a tank solid full of motionless water, it is probable that the initial pressure that would be realized in the tank would be comparable with the pressure in the boiler, and it might conceivably be even greater. This fact, taken in connection with the known fact that a sudden load or pressure has twice the disruptive effect of an equal load when applied gradually, shows how serious the consequences may be, of blowing off into a tank already full of water.

If the outlet of the tank should become partially or completely stopped up from any cause, the water from the boiler will accumulate in the tank, since its only means of escape would then be through the vent pipe, which, under normal circumstances, conveys nothing but steam. In many cases the vent pipe passes up to the top of a high building, and if the water in the tank should accumulate until it overflows through the vent pipe, it is plain that the tank may be exposed to a considerable pressure. For example, if the vent pipe were 100 feet high, and were full, the water within it would produce a static pressure upon the tank of something like 42 or 43 lbs. per square inch; and this pressure would be realized, no matter how gentle the flow from the blowoff, the action here described being distinct from that contemplated in the last paragraph, where the pressure was due to the violence of the discharge into a full tank, without reference to the static head to which the tank might be exposed.

The vent pipe itself is also liable to become more or less completely closed, in winter in our northern latitudes, through the action of frost, particularly if the blowoff pipe leaks slightly. Small quantities of vapor, passing up through the vent pipe in cold weather, may give rise to a coating of ice about the free end of the pipe, and this may increase until the pipe is seriously reduced in area, or possibly stopped up entirely. (We have previously called attention to this sort of danger in the escape pipes of safety-valves. See, for example, *THE LOCOMOTIVE* for January, 1892, page 2.)

Whatever the causes of pressure in blowoff tanks may be, it is certain that such tanks explode, from time to time, owing to the existence within them

of pressures not contemplated by their designers. By way of illustration, we give, below, an account of an explosion of this character, which occurred a short time ago in a steam plant that was supposed to be a model of its kind in all respects, and was described and illustrated as such, in the mechanical journals, shortly after its completion.

The plant in question contained five water tube boilers, numbered from 1 to 5. Nos. 1 and 2 were set together, and so also were Nos. 3 and 4; but Nos. 2 and 3 and Nos. 4 and 5 were separated by alleyways. The blowoff pipes were each $2\frac{1}{2}$ in. in diameter, and all were united into one 3-inch pipe, just before entering the tank that exploded; this tank being placed in front of the alleyway between boilers Nos. 2 and 3, and below the boiler room floor. The safety-valves on the boilers were set to blow off at about 130 lbs., and the pressure usually carried was about 125 lbs. The boiler room was considerably

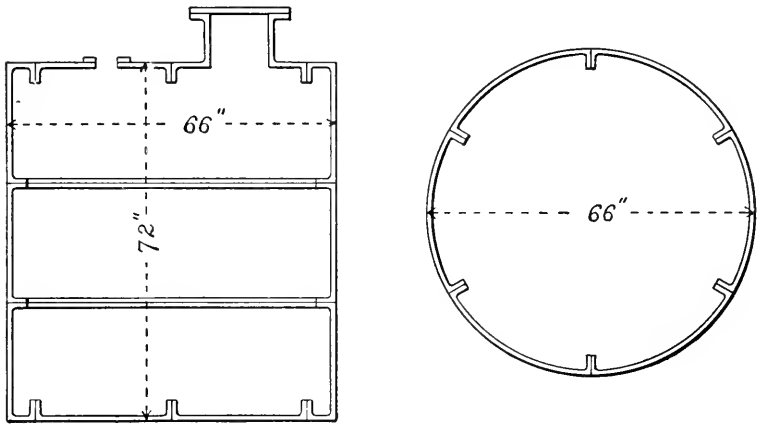

FIGS. 2 AND 3.—VERTICAL AND HORIZONTAL SECTIONS TROUGH EXPLODED TANK.

lower than the sewer, and the water blown off from the boilers was transferred from the tank to the sewer by means of pumps. The vent pipe, for the escape of steam, was 4 in. in diameter near the tank, but within a short distance it opened into a 5-inch pipe, which passed from the level of the boiler room up to a height of 7 feet above the roof of the building; the total height of the vent pipe being 110 feet.

The blowoff tank that exploded was 66 in. in diameter, outside, and 72 in. high, the material being cast-iron. The shell was cast in sections, varying in thickness from $\frac{5}{8}$ in. to $\frac{3}{4}$ in., which were bolted together by means of flanges. The head was also of cast-iron, of the same varied thickness as the shell, and was made in two equal flanged sections, bolted together in the center, the flanges being on the inside and serving as a strengthening rib. The manhole opening was a flanged frame in the form of a nozzle, 12 in. in diameter, 10 in. high, and $\frac{3}{4}$ in. thick. There were four other openings in the head, 2 in., $2\frac{1}{2}$ in., 3 in., and 4 in. in diameter, respectively, which were re-enforced by cast flanges. Only three of these four openings were used, the 3 in. one receiving the blow-off connection from the boilers, and the 4 in. serving for the attachment of the vent pipe, while the suction pipe from the pumps entered through one of the

two others. The general construction of the exploded tank will be understood by reference to Figs. 2, 3, and 4; Fig. 2 showing a vertical section through the middle of the tank, and Fig. 3 a horizontal section across the middle, while Fig. 4 is a view of the top of the tank, showing the openings for the attachments of the pipes.

The explosion occurred, according to our information, almost as soon as the blowoff began to discharge into the tank. The top head was torn off around the line of attachment to the shell, and was thrown into the air. One large fragment of the head, with the manhole frame attached to it, passed up between two 6-inch I-beams that served as tracks for the coal conveyors, bending and spreading them so that they were forced against a 12-inch steam main, which was thereby ruptured, with the result that the steam from the entire battery of boilers was discharged into the boiler room. The only person in the room at the time was the fireman who opened the blowoff pipes on No. 2 boiler, the valve and cock on this boiler being found wide open, with the wrench on the cock. The body of the unfortunate man was found, after the accident, in the ash room, to which he had made his way through the clouds of escaping steam and water. Death was plainly due to the scalding, as he was fearfully burned, from head to foot.

We cannot positively state the cause of this explosion, but we are of the opinion that the tank was full of water and that the failure was brought about by the shock that would be produced under these circumstances, as indicated in an earlier paragraph of the present article. A float was provided to show the level of the water in the tank, and it was the practice in the plant to examine this float before blowing off, in order to make sure that the tank was empty. It appears likely either that the float did not work properly, or that the fireman forgot to examine it, so that he was not aware of the presence of the water. We do not insist upon this particular explanation, however. Our main contention is, that blowoff tanks should be made strong enough to safely withstand any pressure to which they may be subjected, through the failure of either the plant or the workmen to operate correctly; and the accident here described shows the soundness of this view of the case very forcibly.

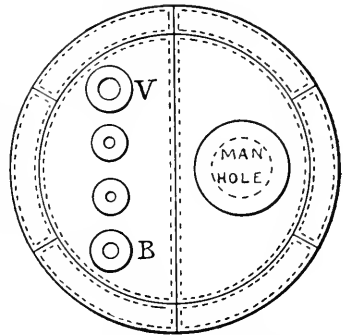

FIG. 4.—COVER OF EXPLODED TANK.
(The vent pipe was connected at *V*,
and the blowoff at *B*.)

IN the issue of THE LOCOMOTIVE for April, 1906, on page 52, we stated that a boiler exploded, on or about February 9, in the Spray Woolen Mills, at Spray, N. C. This statement was made in good faith, and upon what appeared to us to be excellent authority. We have since been informed, however, that the accident consisted in the mere breakage of a piston rod and pulley constituting part of an air compressor, and had nothing to do with a boiler. Also, at the bottom of page 53 of the same issue, we reported a boiler explosion as occurring in a Montana dairy, relying upon a local newspaper which definitely stated that the accident *was* a boiler explosion; whereas we have since learned that it consisted in the failure of a centrifugal milk separator. We intend to have our lists of boiler explosions correct in every particular, and we sincerely regret the errors here noted.

Boiler Explosions.

APRIL, 1906.

(128.) — A boiler exploded, April 1, in a soap works at Torreon, Mex. The fireman, who was the only person in the boiler room at the time, was instantly killed. The boiler, which was a vertical one, passed upward through the roof of the boiler house, and was thrown to a distance of over 800 feet.

(129.) — The boiler of a locomotive drawing a west-bound Lake Shore freight train exploded, April 2, near Amherst, Ohio. The explosion consisted in the failure of the crown-sheet. Fireman A. C. Stage received injuries which were believed to be fatal, and head-brakeman Kelly was seriously scalded, but will recover. The engineer was not injured.

(130.) — On April 2 a boiler exploded in the sawmill of Edward S. Devendorf, Sr., at Chittenango Landing, N. Y. Edward Devendorf, Jr., was killed instantly, and Patrick Baker was injured so badly that he lived but a short time. John Higgins and Jesse Kelsey were also seriously injured, but both will recover.

(131.) — A boiler exploded, April 4, in Loy Livesay's sawmill, at Rogersville, Tenn. Anderson Livesay, E. H. Petros, and Henry Hurd were killed, and Jesse Sizemore, Thomas Livesay, Noah Johnson, M. W. Livesay, and Archibald Rogers were injured.

(132.) — A boiler exploded, on or about April 6, in Elsinger's water-proof factory, at Vienna, Ill. Two persons were killed and twenty were more or less seriously injured.

(133.) — On April 6 a cast-iron elbow ruptured on a blowoff pipe at the plant of the Jersey City Stock Yards Co., Jersey City, N. J. The property damage was considerable.

(134.) — A boiler exploded, April 6, at the Ivanhoe zinc mine, two miles east of Joplin, Mo. Carl Stots was instantly killed, and William Ammerman received injuries which were believed to be fatal. The boiler house was destroyed, and fragments of wreckage were thrown to a distance of half a mile.

(135.) — Four boilers out of a battery of sixteen exploded, April 6, in the power house of the Big Mountain colliery, near Shamokin, Pa. Fireman John Manelek was instantly killed, and watchman William Hoy, Sr., was severely injured.

(136.) — On April 7 a boiler exploded at the plant of the Union Ice Works, Los Angeles, Cal. Mark Hazel and one other man were severely injured. The plant took fire and the total property damage was estimated at \$100,000.

(137.) — A boiler exploded, April 8, on the towboat *H. M. Hoxie*, on the Ohio river, opposite Portland, Ohio. Fireman Joseph Wheeler was injured so badly that he died, on the following day, in a hospital at Parkersburg, W. Va. At last accounts Fireman John Moran was missing, and was believed to be drowned. Three other members of the crew likewise suffered broken bones and serious burns. The tug, which belonged in Pittsburg, sank within five minutes of the explosion.

(138.) — A slight boiler explosion occurred, April 9, in the Illinois Asylum for Feeble Minded Children, at Lincoln, Ill.

(139.) — The elbow of a blowoff pipe ruptured, April 10, in the Cadillac Handle Co.'s plant, Cadillac, Mich.

(140.) — On April 10 a boiler exploded in the Franklin Machine & Steam Boiler Works, Brooklyn, N. Y. George O'Neill, Alfred Allday, George Smith, and six other men, were injured. It was thought that the injuries of O'Neill and Allday might prove fatal.

(141.) — A boiler ruptured, April 11, in the Cleveland Salt Co.'s plant, Cleveland, Ohio. Nobody was injured.

(142.) — Engineer Charles W. Ranck was instantly killed, and fireman Bartholomew Weissner was terribly scalded and cut, on April 14, by the explosion of the boiler of a locomotive near Frazer, Chester Co., Pa. The boiler was thrown to a distance of about 100 yards.

(143.) — A cast-iron sectional boiler exploded, April 14, in a manufacturing plant belonging to the Estate of Robert Cornelius, on Cherry street, Philadelphia, Pa. Fireman William Scott was slightly injured.

(144.) — The boiler of a dinkey locomotive exploded, April 15, in the Boston Iron & Steel works, McKeesport, Pa. A big ladle of metal which stood near the locomotive exploded immediately afterward, apparently as the result of the explosion of the boiler. John Navson and George Henry were seriously burned and scalded.

(145.) — The boiler of a freight locomotive exploded, April 16, near Jarratt, Va. Brakeman Emmett Scott was seriously injured, and conductor Toone was also scalded, though less seriously.

(146.) — A slight explosion occurred, April 16, at the United Engineering Works, Alameda, Cal. Charles Lind, an electrician, was terribly scalded.

(147.) — A main stop valve failed, April 18, in Frederick Feils' brewery, Philadelphia, Pa. Engineer Emil Wolfinger was injured.

(148.) — A blowoff pipe ruptured, April 18, in the Peninsular Lumber Co.'s plant, University Park, Ore. Perry Gaines was injured.

(149.) — On April 18 the threads stripped from a nipple under the safety valve on a boiler in the Hotel Vendome, San Jose, Cal. The valve was blown from the boiler, but the property damage was trifling.

(150.) — On April 20 a tube collapsed in a boiler at the American Steam Laundry Co.'s plant, St. Louis, Mo. Edward Wrensrow and W. Annerler were scalded.

(151.) — A boiler exploded, April 23, in St. Joseph's Orphan Asylum, Philadelphia, Pa. Nobody was injured, but the property loss was estimated at several thousand dollars.

(152.) — A tube ruptured, April 24, in a water-tube boiler at the electric light and power plant of the People's Power Co., Moline, Ill. F. Farley was slightly injured, and the boiler was considerably damaged.

(153.) — A boiler exploded, April 24, in John Scheular's bakery, Hoboken, N. J. Gustave Dirchs and John Schmidt were injured seriously.

(154.) — On April 26 a tube failed in a water-tube boiler in the Lyon Cypress Lumber Co.'s plant, Garyville, La. (See also explosion No. 161, below.)

(155.) — A boiler exploded, April 27, at Mine No. 1, on the M. C. & C. railroad, about a mile and a half north of Broadwell, Ohio. The explosion occurred at the noon hour, and nobody was injured.

(156.) — The boiler of a locomotive drawing an east-bound freight train on the Pennsylvania railroad exploded, April 27, at Ducklow Tower, Steelton, Pa. Engineer J. F. Good was killed, and fireman C. H. Lefever and brakeman J. J. Wallower were fatally injured. The hypothesis was advanced that the explosion was caused by a stick of dynamite accidentally dropped on the track; but there appears to be no evidence to substantiate this suggestion.

(157.) — The boiler of freight engine No. 2,300, of the Baltimore & Ohio railroad, exploded, April 28, at Wilsonburg, seven miles west of Clarksburg, W. Va. Engineer D. F. Board and brakeman O. W. Bond were instantly killed. Fireman Ralph S. Warnack's skull was fractured, and it was at first thought that he must die. Later advices state, however, that he is well on the road to recovery. The property loss was estimated at from \$2,500 to \$3,000.

(158.) — An explosion occurred, April 28, in a water-tube boiler used in connection with a blast furnace at the plant of the Shenango Furnace Co., Sharpsville, Pa. The boiler was badly damaged.

(159.) — A blowoff valve ruptured, April 28, in the Norfolk Cold Storage & Ice Co.'s plant, Norfolk, Va. The damage was small.

(160.) — Several cast-iron headers fractured, April 28, in a water-tube boiler at the plant of the Liquid Carbonic Co., Pittsburg, Pa. The property damage was confined to the boilers.

(161.) — On April 30 several tubes failed in a water-tube boiler in the Lyon Cypress Lumber Co.'s plant, Garyville, La. The property loss was confined to the boiler. (See also explosion No. 154, above.)

(162.) — A slight explosion occurred, April 30, in the Bennett Furniture Co.'s plant, Louisville, Ky. Engineer Nelson Crull was slightly burned. The residence of Frederick Calvert, adjoining the plant in which the explosion occurred, was damaged to the extent of about \$300.

MAY, 1906.

(163.) — A boiler exploded, May 2, in the sawmill of Myers & Burgess, near Arm, a station on the Gulf & Ship Island railroad, about twenty miles north of Columbia, Miss. Fireman Edward Wagner was thrown 150 feet and instantly killed, and Joseph Smith was seriously injured. The mill was badly damaged.

(164.) — A boiler exploded, May 3, in C. R. Zinn's mill, at Mystic, near Centerville, Iowa. Mr. Zinn, the proprietor, was killed, his body being thrown to a distance of 150 feet.

(165.) — A boiler exploded, May 3, in Thomas Razor's sawmill, three miles east of Farmers, Ky. Walter Scott was instantly killed, Robert Jones was seriously injured, and the mill was totally wrecked.

(166.) — On May 3 a tube ruptured in a water-tube boiler at the Wellston, Ohio, plant of the Lehigh Portland Cement Co.

(167.) — A boiler exploded, May 3, in Burns & Wheeler's sawmill, at Newaygo, Mich. Ralph Byers was instantly killed.

(168.) — A boiler exploded, May 4, in the pumping station of the J. M. Guffey Petroleum Co., at Spindle Top, Tex. Two men were scalded about the feet. The property loss was estimated at \$2,000.

(169.) — On May 5 a flue collapsed in a boiler in the Kentucky-Tennessee Property Co.'s ice factory, at Danville, Ky. The property loss was confined to the boiler, which was badly damaged.

(170.) — A boiler tube ruptured, May 5, in the Wilson Saw & Manufacturing Co.'s plant, Port Huron, Mich.

(171.) — A boiler exploded, May 5, in Pearson & Allen's stave mill, on Flint Run, near Elizabeth, W. Va. Abram Pearson, Dallas Allen, Ward Nutter, Abraham Bell, Coe Bell, and James Jeffers were injured, and the entire plant was destroyed.

(172.) — On May 7 the boiler of G. A. Whitney's portable mill, three miles west of Glover's Switch, near Standish, Mich., exploded. Otis Turner was seriously scalded. One of the accounts of this explosion that we received says: "It was not an explosion, as the boiler was full of water, and burst at the bottom, in the fire-box." This curious sentence was doubtless written by a person who was saturated with the common but entirely erroneous idea that a boiler cannot explode except on account of low water. The idea appears to be, that if there was demonstrably a sufficient quantity of water present, then we mustn't call the phenomenon that takes place an "explosion"!

(173.) — A flue failed, May 8, in a boiler at the Ætna Cement Co.'s plant, Fenton, Mich. Edward Walker was killed, and Andrew Wilson was badly scalded. The property loss was small.

(174.) — A boiler exploded, May 10, in Brown Bros.' tile factory, at Crawfordsville, Iowa. Walter Menefee and Henry Hough were instantly killed, and the property loss was estimated at \$7,000.

(175.) — A tube ruptured, May 11, in a water-tube boiler in the plant of the Lockhart Iron & Steel Co., McKees Rocks, Pa. Frank Cosock, Thomas Taylor, a man named Miller, and another man whose name we have not learned, were injured, one of them quite seriously so. The boiler was damaged considerably.

(176.) — On May 11 a boiler exploded in the plant of the Big Pine Lumber Co., at Colfax, La. W. A. Porter, Louis Henderson, and James Carter were killed. The property loss was estimated at \$10,000.

(177.) — The boiler of a large steam automobile exploded, May 13, at Twenty-ninth and Farnum streets, Omaha, Neb. Six persons, who were in the vehicle at the time, were injured, and fragments of the machine were thrown to a distance of two blocks.

(178.) — The boiler of a Northern Central freight locomotive exploded, May 16, at Herndon, near Sunbury, Pa. Engineer Charles F. Gottschall and F. E.

Duke were killed outright, and fireman Ernest White was scalded so badly that he died on the following day.

(179.) — A tube ruptured, May 18, in a water-tube boiler in the plant of the Lehigh Portland Cement Co., Ormrod, Pa. John Titrock was injured.

(180.) — A slight explosion occurred, May 19, in the Calumet Brewing Co.'s plant, South Chicago, Ill.

(181.) — The boiler of a Southern Pacific locomotive exploded, May 19, seven miles east of Wells, Nev., killing engineer L. F. Zimmerman and fireman M. S. Irwin. The locomotive was demolished.

(182.) — A heating boiler exploded, May 19, in the Selfridge greenhouse, Lake Geneva, Wis. The property loss was considerable.

(183.) — On May 23 a boiler exploded at the Cork & Bottle coal mine, in West Scranton, Pa. The mine was afire and the boiler that exploded was used for flushing sand into the mine, in the hope of extinguishing the fire.

(184.) — The boiler of a locomotive belonging to the Continental Coal Co. exploded, May 25, at Tulsa, I. T. The locomotive was destroyed. The report that we have received states that the accident was due to the explosion of dynamite, placed on the track by enemies of the coal company, for the purpose of destroying the locomotive. This appears to be a matter of pure conjecture, however, and we include the accident in our regular list of boiler explosions because we have known of many cases in which boiler explosions have been attributed without adequate reason to high explosives like dynamite, by persons who, being unfamiliar with the fearful destructiveness of steam, felt impelled to adopt the dynamite hypothesis to account for the observed violence of the explosion.

(185.) — The boiler of locomotive No. 14, of the U. T. A. & M. railway, exploded, May 26, at Arkadelphia, Ark. P. J. Calhoun was instantly killed, and a boy whose name we have not learned was injured so badly that he died on the following day. Fireman John Dunn and another man, John Hughes, were injured seriously but not fatally. The locomotive was wrecked.

(186.) — On May 28 a number of tubes and headers ruptured in a water-tube boiler in the City of South Bend Water Works, South Bend, Ind. The damage was confined to the boiler.

(187.) — The boiler of a Philadelphia & Reading locomotive exploded, May 29, at Port Kennedy, Pa. Conductor John Schultz and fireman George Greenwalt were injured seriously and perhaps fatally, and the locomotive and two cars were wrecked.

(188.) — On May 30 the boiler of a Texas & Pacific shovel, No. 3, exploded, at Cleveland, La. Engineer T. M. Smith, fireman George Osborn, and trainman John Child were scalded.

(189.) — A boiler exploded, May 31, at Schmeck's stone quarry, Reading, Pa. Nobody was near it at the time. The boiler was badly torn.

(190.) — A tube ruptured, May 31, in a water-tube boiler in the Schwartzchild & Sulzberger Co.'s packing plant, Kansas City, Mo. The property loss was small.

JUNE, 1906.

(191.) — On June 4 the elbow of a blowoff pipe ruptured in the plant of the Oliver Typewriter Co., Woodstock, Ill.

(192.) — The feed pipe pulled out of a boiler in the American Woolen Co.'s rag mill, at Franklin, Mass., on June 4.

(193.) — On June 5 several tubes of a water-tube boiler pulled out of a drum in the plant of the Lyon Cypress Lumber Co., Garyville, La., causing damage to the boiler of about \$1,000.

(194.) — A cast-iron steam cap blew off of a sectional boiler, on June 8, in an office building belonging to the Forrest Estate, on South Fourth street, Philadelphia, Pa.

(195.) — The boiler of a locomotive belonging to the F. H. & C. W. Good-year Co., exploded June 9, at Medix Run, Pa. Fireman Edward Singleton was killed, and engineer H. D. Miller and one other man were injured. The property loss was estimated at \$1,800.

(196.) — A tube ruptured, June 12, in a water-tube boiler in the Fort Wayne Rolling Mill Co.'s plant, Fort Wayne, Ind. John Dornick was injured.

(197.) — On June 17 a slight boiler explosion occurred in a plant owned by the Dayton Coal & Iron Co., Dayton, Tenn. The damage was confined to the boiler.

(198.) — A boiler exploded, June 18, in E. S. Harrah & Co.'s sawmill, at Leander, W. Va. Gideon Legg was slightly injured.

(199.) — A boiler exploded, June 18, in Thomas McLeod's sawmill, about ten miles south of Perry, Fla. One workman was fatally injured, and the proprietor and another man were injured painfully but not fatally.

(200.) — On June 20 a boiler exploded in the Ontario electric light plant, near Boise, Idaho.

(201.) — The drum of a water-tube boiler ruptured, June 20, in the Minnesota Harvester Co.'s plant, Hazel Park, St. Paul, Minn. The damage was confined to the boiler.

(202.) — On June 21 a boiler exploded in a sawmill at Henderson, near Jackson, Tenn. Alexander Barnes was instantly killed, and his brother, Charles Barnes, was badly injured.

(203.) — A boiler exploded, June 22, in John Miranda's sawmill, Calhoun county, W. Va. William Wolfsong was instantly killed, the owner of the mill was fatally injured, and several other persons received lesser injuries.

(204.) — Several tubes pulled out of the drum of a water-tube boiler, on June 22, in the Lyon Cypress Lumber Co.'s plant, Garyville, La. (See also No. 193, above.)

(205.) — A flue failed, June 23, in the electric light plant at Chillicothe, Ill. Fireman Powers was scalded painfully, and the machinery of the plant was considerably damaged.

(206.) — On June 23 a tank of some sort burst in Frederick Hoerter's butcher establishment, Louisville, Ky., scalding engineer Cora N. Holden so badly that he died a few hours later.

(207.) — On June 24 a blowoff pipe pulled out of a boiler at the Grove Mill Paper Co.'s plant, New Windsor, N. Y. Fireman Edward Fisher was injured.

(208.) — A tube ruptured, June 24, in a water-tube boiler in the Fort Wayne & Wabash Valley Traction Co.'s power house, La Fayette, Ind.

(209.) — A boiler exploded, June 25, in Jones, Jackson & Mason's cheese-box factory, at Eldorado, Ont. Herbert Richards and two of the owners of the factory (Messrs. Jackson and Mason) were scalded, and the mill was badly shaken.

(210.) — On June 25 a blowoff pipe ruptured in L. Screechfield & Son's electric light plant, Lee's Summit, Mo.

(211.) — A boiler exploded, June 25, at Buchanan Oil Well No. 1, near Woodsfield, Monroe county, Ohio. Two oil drillers were fearfully burned, and one of them (named Stoner) died on the following day.

(212.) — A number of tubes failed, June 25, in a water-tube boiler at the plant of the Carbonic Dioxide Co., Chicago, Ill.

(213.) — A slight boiler explosion occurred, June 25, in the Standard Cypress Co.'s plant, Jacksonville, Fla.

(214.) — Several sections of a cast-iron heating boiler fractured, June 26, in Houseman & Co.'s restaurant, Boston, Mass.

(215.) — A slight boiler explosion occurred, June 29, in the J. M. Bates factory, Attleboro, Mass.

(216.) — A small boiler used for heating water exploded, June 30, in the dining room of the Grand Trunk railroad, at Durand, Mich. John Taubitz, a clerk employed in the room, was terribly scalded.

(217.) — The boiler of locomotive No. 36, on the Richmond, Fredericksburg & Potomac railroad, exploded, June 30, between Doswell and Ruther Glen, Va. Fireman Julien E. Hudgins, who was firing at the time, was fearfully burned. The explosion consisted in the failure of the crown-sheet.

JULY, 1906.

(218.) — An explosion occurred, July 1, in the power house of the Rapid Transit Railway, at Syracuse, N. Y. One man was badly scalded.

(219.) — A boiler exploded, July 3, in the power house of the Camden Water, Light & Ice Co., Camden, S. C. The plant, which was owned by Frank K. Bull, of Racine, Wis., was destroyed, and the property loss is estimated at from \$50,000 to \$75,000.

(220.) — A slight boiler explosion occurred, July 5, in the Marlboro Cotton Mills, McColl, S. C. The damage was confined to the boiler.

(221.) — On July 6 a boiler exploded in the Beringer block, at Saginaw,

Mich. Edward Foehlan and Carl Consendai were killed, and John Consendai and John Larger were fearfully burned. The building took fire after the explosion, and the total property loss was large.

(222.) — The boiler of a threshing machine outfit exploded, July 7, on C. H. Johnson's farm, northwest of Jacksonville, Ill. Roy Caldwell was scalded so badly that he died twelve hours later. Roy Libby was also scalded, but not fatally so. According to one report, Emory Carter, Louis Caldwell, and Albert Higgs likewise received minor injuries.

(223.) — On July 10 a tube burst in a water-tube boiler in the Depot street plant of the Cincinnati Traction Co., Cincinnati, Ohio. Lewis Paddenphol was scalded so badly that he died a few days afterward.

(224.) — A slight explosion occurred, July 10, in a planing mill at McMillan, Wis.

(225.) — The boiler of a threshing machine outfit exploded, July 12, on Mrs. Green Cinningham's farm, near Princeton, Ind. Engineer Henry Elselder was terribly scalded.

(226.) — On or about July 12 a boiler exploded in Joseph S. Stone's sawmill, at Long Branch, near Lumberton, N. C. Mr. Stone was killed.

(227.) — The boiler of a Southern Pacific locomotive exploded, July 12, at a small station called Clawson, near Ashland, Ore. Engineer S. L. Patrick and fireman Holmes were seriously injured.

(228.) — On July 18 a cast-iron header ruptured on a water-tube boiler located in a building owned by J. W. T. Nichols, Chauncey street, Boston, Mass.

(229.) — A slight explosion occurred, July 20, in the Oakland Coal & Coke Co.'s plant, at Corinth, W. Va.

(230.) — A tube ruptured, July 20, in a water-tube boiler at the American Brewing Co.'s plant, Indianapolis, Ind. Fireman John Bowman was injured.

(231.) — A tube pulled out of a water-tube boiler, July 21, in the Standard Sanitary Manufacturing Co.'s works, Louisville, Ky.

(232.) — The boiler of locomotive No. 1591, on the Erie railroad, exploded, July 22, on the Jefferson division, near Susquehanna, Pa. Fireman Harry Stuart was scalded to death, and three other members of the train crew received slight injuries.

(233.) — On July 22 a tube ruptured, and several cast-iron headers fractured, in a water-tube boiler at the plant of the American Car & Foundry Co., Berwick, Pa. The boiler required extensive repairs, but nobody was injured.

(234.) — A slight boiler explosion occurred, July 22, in the Horn & Supply Co.'s factory, Leominster, Mass.

(235.) — A boiler exploded, July 23, in the Bentley Lumber Co.'s plant, four miles from Brantley, Ala. Night watchman James Jones was instantly killed, and Frank Baker received injuries which were thought to be fatal. The plant was wrecked.

(236.) — A tube pulled out of a water-tube boiler, July 23, in the Interstate Iron & Steel Co.'s plant, at East Chicago, Ind. Fireman Alexander Sharka was scalded.

(237.) — A rendering tank exploded, July 23, in the plant of the Portland Rendering Co., near Portland, Ore. Frank Pelton was killed, and F. F. Lent (one of the owners of the plant) was severely injured. The building in which the tank stood was wrecked, and the property loss was estimated at \$3,000.

(238.) — A blowoff pipe ruptured, July 24, in the Midland Roller Mill Co.'s flouring mill, at Jackson, Tenn.

(239.) — A peculiar accident occurred, July 27, at the Patterson & Robinson coal plant, on the Monongahela river, at Hays station, eight miles from Pittsburg, Pa. George Seibert, a watchman, was murderously assaulted by another man, and was left for dead. Regaining consciousness, he crawled to a physician's office, where his wounds were dressed; but in his absence from the plant the boiler exploded, wrecking the tiple and setting fire to the power house and other buildings, and causing a total loss of about \$75,000.

(240.) — On July 28 a slight boiler accident occurred at the plant of the Bullard Machine Tool Co., Bridgeport, Conn. The damage was confined to the boiler.

(241.) — A slight rupture occurred, July 29, in a boiler at the St. John Wood Working Co.'s plant, Stamford, Conn.

(242.) — A boiler exploded, July 30, in the Vincennes Paper Mills, Vincennes, Ind. Harry Borders and Lafayette Lichey were killed, and Charles Connors was seriously injured. Some twenty other persons are said to have received slight injuries. The boiler house was destroyed, and the property loss was estimated at from \$15,000 to \$50,000.

(243.) — A boiler explosion occurred, July 31, in the League Island Navy Yard, near Philadelphia, Pa. Alexander Johnson was burned so badly that he died on the following day.

AUGUST, 1906.

(244.) — On August 1 a boiler exploded in the Bacon-Underwood Veneering Co.'s plant, at Choctaw Point, near Mobile, Ala. Night fireman Paul Phillips was killed, and the boiler room was wrecked.

(245.) — A slight boiler explosion occurred, August 1, in A. L. Hoover & Son's hotel, at Lincoln, Neb.

(246.) — A tube ruptured, August 4, in a water-tube boiler at the Wylie Mills, Chester, S. C.

(247.) — A small boiler exploded, August 4, at the University of California, Berkeley, Cal. Ivan Ball, a junior in the university, was seriously burned.

(248.) — On August 4 a tube split in a water-tube boiler at the Madison Ave. station of the Public Service Corporation of New Jersey, Plainfield, N. J.

(249.) — A tube ruptured, August 4, in a boiler at the electric power plant of the People's Railway Co., Wilmington, Del.

(250.) — A slight explosion occurred, August 6, at the plant of the Hutchinson Kansas Salt Co., Hutchinson, Kans.

(251.) — A header fractured, August 8, in a water-tube boiler at the Germania Bank, New York City.

(252.) — A boiler ruptured, August 9, in L. T. Kenny's flouring mill, Hawarden, Iowa.

(253.) — On August 11 a blowoff pipe ruptured at an elbow in the Merchants' Mutual Light & Power Co.'s plant, Santa Barbara, Cal. The property loss was considerable.

(254.) — A tube ruptured, August 13, in a water-tube boiler at the hotel and sanitarium of I. M. Putnam, San Antonio, Tex.

(255.) — A heater exploded, August 15, at the West End Furniture Co.'s factory, Rockford, Ill. Engineer George I. Jenkins was terribly scalded.

(256.) — A boiler used for furnishing steam for distilling peppermint exploded, August 15, on William Mohney's farm, three miles west of Three Rivers, Mich. William Mohney and his son, Roy Mohney, were killed, and Warren Mohney and Milo Mohney were seriously injured.

(257.) — The boiler of locomotive No. 13, of the Birmingham Southern railroad (Tennessee-Republic company) exploded, at Ensley, Ala. Engineer Edward Brinker and fireman Claude White were killed, and Thomas Edwards and one other man were injured. The locomotive was totally wrecked.

(258.) — A number of headers fractured, August 18, in a water-tube boiler at the Milwaukee Coke & Gas Co.'s plant, Milwaukee, Wis.

(259.) — On August 19 a tube exploded in a water-tube boiler at the plant of the Alsens American Portland Cement Co., Alsens, N. Y. Fireman Thomas Yonwanawich was severely scalded.

(260.) — A Wabash locomotive boiler gave way, August 20, in the yards near Kansas City, Mo. The explosion was slight, but it resulted in the severe injury of Solomon Kelley, who was employed in the yards as a hostler.

(261.) — A boiler used for operating a steam shovel exploded, August 21, on the Houston & Texas Central railroad, near Mexia, Tex. Engineer J. R. Watson, fireman J. O. W. Sanders, and a laborer named J. S. McKennon were severely injured.

(262.) — On August 22 a serious boiler explosion occurred in the power station of the Columbus, Delaware & Marion Railway Co., at Marion, Ohio. The boiler that exploded was of the water-tube type. Albert Riley, Charles Dutton, G. F. Dutton, and Gottlieb Trefy were seriously injured. The building was badly damaged, and the property loss was probably about \$10,000.

(263.) — A boiler exploded, August 22, in the Eureka Brick Works, at Sevastopol, Des Moines, Iowa.

(264.) — A tube exploded, August 23, in a water-tube boiler at the Absecom Pumping station of the water department of Atlantic City, N. J. Fireman James Madara was fatally injured, and died within a few hours. Two other men received slight injuries.

(265.) — On August 24 a slight boiler explosion occurred in the Columbus Canning Co.'s plant, Columbus, Ind.

(266.) — A tube failed, August 24, in a boiler on the steamer *Burton*, near Tacoma, Wash.

(267.) — A slight boiler explosion occurred, August 25, in the Brandon & Beal brewery, at Leavenworth, Kans.

(268.) — The boiler of locomotive No. 3433, of the New York Central railroad, exploded, August 26, midway between Herkimer and Little Falls, N. Y. Engineer Christopher Wagner and fireman Frederick Hall were killed, and the locomotive was badly wrecked.

(269.) — On August 26 an automatic stop and check valve ruptured in the plant of the General Electric Co., at Schenectady, N. Y. Harmon Post, a water-tender, who was opening the valve at the time, was blown from the boiler and killed.

(270.) — A tube exploded, August 26, in a water-tube boiler at the plant of the Kosmos Portland Cement Co., Kosmosdale, Ky. Engineer Lewis Allen was injured, and the boiler was considerably damaged.

(271.) — The boiler of a threshing machine outfit exploded, August 27, at Altona, Man. Jacob Hirsch and his son, Albert Hirsch, were badly injured.

(272.) — A boiler exploded, August 28, in the Keith Ward tract, on Spindle Top, near Beaumont, Tex. Fire followed the explosion, and the total property loss was estimated at from \$40,000 to \$50,000. The boiler that exploded belonged to the Sunset Oil Co., of Houston, Tex., and was operated by C. A. Richardson.

(273.) — A boiler exploded, August 29, in Evan Carter's sawmill, a mile and a half east of Duncan Falls, Ohio. Harry Mautz was killed, and Charles Staker, Evan Carter, and Benjamin Johnson were injured.

(274.) — An explosion occurred, on or about August 30, in the Chattanooga River Brick Co.'s plant, near Chattanooga, Tenn. A. S. McNabb was severely injured. Two boilers were being connected at the time, and the injured man was on the top of one of them.

(275.) — A boiler exploded, August 30, in Noah Webster's canning factory, at Secretary, Md. Fourteen persons were injured with sufficient severity to require immediate medical attention.

(276.) — The boiler of a steam shovel, in use upon the Big Four railroad exploded, August 31, at Danville, Ind.

ON June 9, Charles Stolke, a workman employed by the Woolen & Callon Co., was seriously injured at the Technical Institute, Indianapolis, Ind. He had entered a boiler, presumably for the purpose of inspecting, cleaning, or repairing it, and while he was within it a fireman, not knowing the circumstances, is said to have opened a valve in a pipe connecting the empty boiler with one that was carrying steam. Stolke was badly scalded about the head, shoulders, and hands, but he succeeded in reaching the manhole, through which he was assisted.

The Locomotive.

A. D. RISTEEN, PH.D., EDITOR.

HARTFORD, OCTOBER 15, 1906.

THE LOCOMOTIVE can be obtained free by calling at any of the company's agencies. Subscription price 50 cents per year when mailed from this office. Bound volumes one dollar each. (Any volume can be supplied.)

Forty Years of Service.

On October 6 the Hartford Steam Boiler Inspection and Insurance Company completed its fortieth year of public service, and in making note of the fact we desire especially to recognize and acknowledge our indebtedness to our numerous patrons and policy-holders for their very generous and continuous support and patronage, and to extend to them, and to steam users in general, our sincere acknowledgments and cordial greetings.

The Hartford was the first company to organize in America for the sole purpose of making the use of steam for power purposes both practicable and safe, and for the scientific design, installation, and management of steam power plants; and today, after a lapse of forty years, it is still the only company making an exclusive specialty of steam boiler insurance.

In order to meet the needs of manufacturers using steam for power, and render them a service of the greatest practical value, the Hartford company has provided itself with every facility for the scientific treatment of the numerous problems that pertain to the use of steam, and has built up and maintained an organization whose magnitude is perhaps not fully appreciated by any person not directly connected with the company. It has established, and equipped with modern appliances, and placed under the management of specialists in their respective lines, the following departments:

(a) It maintains a department of Designing and Drafting, and is fully equipped to furnish plans and specifications, accompanied by appropriate blue-prints, for the complete installation of new steam plants, or for the reconstruction or extension of old ones.

(b) It maintains a department of Chemistry for the analysis of waters in order to determine their fitness for use in generating steam, and to discover the proper remedial treatment to be applied to waters that have been found to give trouble of any kind.

(c) It maintains a department of Supervision and Inspection, and has a large corps of skilled mechanics, who are permanently employed, and are located at strategic points throughout nearly every state and territory in the Union.

(d) It maintains a department of Research and Publication, in which the world's progress in steam engineering and allied subjects is carefully followed, and which edits and publishes THE LOCOMOTIVE, a quarterly journal which is mailed free to our policy-holders, and which is devoted to mechanics, and chiefly to the consideration and discussion of such practical questions relating

to steam and steam equipment as come within the actual experiences of the company.

The Hartford company, therefore, as now organized, is provided with facilities for dealing scientifically with every component hazard pertaining to the use of steam for power; and in conjunction with its designing and drafting department, it is superbly equipped to render invaluable service in the way of furnishing plans and specifications for the layout and construction of new plants, in conformity with the best modern methods for securing a maximum efficiency. It is highly gratifying to look back over the years that have passed, and observe the steadily increasing appreciation of our efforts, as a knowledge of the company, and of its resources and methods, has spread among steam users. At the present day it is conservatively estimated that about nine out of every ten insured boilers in the New England States, and about seven out of every ten throughout the United States, are under the care and inspection service of the Hartford company.

The company has grown to its present large proportions, and its good name has been established and maintained, through the harmonious interworking of its several auxiliary departments, but more particularly through the efficiency of its inspection service. The practice of making regular, frequent, and thorough inspections of the boilers under its care was initiated by the incorporators of the company, and has since been consistently and persistently followed. It was based upon the theory that, while full *indemnity* should be given to its patrons for the losses sustained under their policies, the company could perform a far higher service to them by affording *immunity* from explosions, since no mere monetary payment can compensate for a disaster in which property and lives are involved, if such disaster could have been averted. The sagacity and foresight of the founders of the company have been proven by the practical experience of forty years; for its records show that while the inspection expenses alone have consumed about one-half or fifty per cent. of the premiums received, the loss-ratio has not exceeded eight per cent. Stated in other words, the inspection service of the Hartford company has afforded steam users, throughout the past forty years, a protection averaging within about eight per cent. of absolute immunity from explosions,—a variation so small as to be well nigh accounted for by the unavoidable fallibility of men and materials.

For the purpose of indicating the magnitude and character of the inspection service rendered by the Hartford, we submit, below, a brief analysis of the work that was performed, and the results that were obtained, during the year 1905, by the inspection department of the company; and we also indicate the exact cost to the assured of the service thus rendered. We are satisfied that no one is better qualified to judge of its value than a manufacturer; and we are equally confident that every manufacturer will agree that the service that was rendered, when considered in connection with the results that were attained, was furnished at a cost as reasonable as is consistent with efficiency.

\$4.22 : Would you consider this sum an unreasonable expenditure for a thorough and careful inspection of a boiler by a skilled mechanic, specially instructed and trained for that particular work? The Hartford, last year, made 291,041 inspections, averaging 797 inspections per day for every day in the year, including Sundays; and if the entire premiums received were charged solely for these inspections, the sum of \$4.22 would represent the average cost, to the assured, of each inspection.

\$7.92 : Would you consider this sum an exorbitant expenditure for the discovery of a defect in your boiler, and definite instructions in reference to remedying it? The Hartford discovered, last year, 155,024 defects, averaging 424 defects per day for every day in the year, including Sundays; and if the entire premiums received were charged solely for the discovery of those defects, the sum of \$7.92 would represent the average cost, to the assured, of the discovery of each defect.

\$86.44 : Would you consider this sum an unjustifiable expenditure for the discovery of a *dangerous* defect in your boiler? The Hartford discovered, last year, 14,209 dangerous defects, averaging 39 dangerous defects per day for every day in the year, including Sundays; and if the entire premiums received were charged solely for the discovery of dangerous defects, the sum of \$86.44 would represent the average cost, to the assured, of the discovery of each dangerous defect.

\$1,631.10 : Would you consider this sum an unwarranted expenditure for the discovery of a defect so vital as to justify the condemnation of your boiler? The Hartford, last year discovered 753 defects so vital as to lead to the condemnation of 753 boilers, thus condemning, on an average, two boilers per day for every day in the year, including Sundays; and if the entire premiums received were charged solely for those inspections in which defects were discovered of so serious a character as to justify the condemnation of the boiler, the sum of \$1,631.10 would represent the average cost, to the assured, of each inspection resulting in the condemnation of a boiler.

It should be noted that no account whatever has been taken, thus far, of either the protective or the contingent value of the insurance feature of the policy, nor of the value to a steam user of the superior inspection service rendered by the Hartford, so far as it relates to the maintenance of the boilers, and the entire steam equipment, in a good physical and operating condition. When these additional features are considered, it becomes apparent that a policy in the Hartford secures to a steam user insurance of a four-fold character:

(1) It *insures* the making of thorough and regular inspections, by *permanently employed*, salaried inspectors of the company.

(2) It *insures*, through the thoroughness and frequency of its inspections, the discovery of any defects that may exist, and timely recommendations with respect to remedying them.

(3) It *insures* full and complete pecuniary compensation for any loss or damage occasioned by an explosion, collapse, or rupture of the boiler, while the policy that covers it is in force.

(4) It *insures*, in case of an explosion, that the claims arising will be promptly adjusted and paid, under a policy whose provisions are broader, more equitable, less technical, and less restrictive, than any issued by any other company.

THE Hartford Steam Boiler Inspection and Insurance Company publishes a small book entitled *The Metric System*, which explains the metric system, and gives a brief history of it, and contains very complete tables for reducing metric units to their English and American equivalents, and the converse. It is sent, postpaid to any address, upon the receipt of \$1.25; and a special edition, printed on bond paper, may be had for \$1.50. The price charged is intended to merely cover the expense of publication.

The Properties of Steam.

SECOND PAPER.—BATELLI'S EXPERIMENTS ON THE PRESSURE AND DENSITY OF STEAM, BELOW 240° C.

Since the days of Regnault, many experimenters have studied the relation between the pressure and temperature of saturated steam, and our knowledge of the subject has been advanced materially, though not to an extent sufficient to permit us to ignore the results that Regnault has given. Prominent among the later investigators is Angelo Battelli, professor of experimental physics in the University of Padua, Italy, whose observations, though less numerous than Regnault's, have covered a wider range of temperature and pressure. They were made, moreover, by totally different methods, and would be valuable for this reason, if for no other.

Battelli's work is worthy of greater attention than it appears to have received from English and American writers; but his memoirs were written in the Italian language, and have never been rendered into English, and this fact alone would prevent a large proportion of English-speaking students and engineers from becoming familiar with them at first hand. Furthermore, the Italian periodical in which they were published is to be found in comparatively few of our libraries, and is therefore difficult of access, at all events to American readers. Excellent but incomplete translations of some of Battelli's memoirs (and perhaps of all) are available in the French, yet the French versions omit a large amount of the valuable detail that is to be found in the original Italian.

In view of these circumstances, we feel that Battelli's experiments should receive careful consideration in the present series of articles, so far as they relate to the properties of saturated steam; and we therefore propose, not only to give his general results, but also to explain at some length the means by which those results were obtained.

The experiments that we are about to consider form part of an extensive investigation of the properties of vapors in general, several liquids besides water having been studied by similar methods, and with the same care. Save for the fact that reference to one memoir upon ether vapor is necessary in order to properly describe his apparatus, we shall confine our attention, at present, to the experiments made upon the vapor of water.

Battelli's experiments on the pressure and density of steam were published in two separate memoirs, one of which deals with temperatures ranging from just below the freezing point of water, up to about 230° C. (446° Fahr.), while the other relates to temperatures between 310° C. and 375° C. (590° and 707° Fahr.), the latter temperature being above the "critical point" of water. (See THE LOCOMOTIVE for November, 1891, page 172.) The reason for this division of the subject was, that it was found to be inadvisable to make use of the same apparatus for the entire range of temperature covered by the experiments. For the lower temperatures (up to 230° C. or thereabouts), glass was used in constructing certain of the essential parts, so that the observer could look directly into the apparatus and note, with the eye, the deportment of the vapor under varying conditions of temperature and pressure. This plan could not be followed at the higher temperatures, however, partly because it was then necessary to deal with pressures as great as 235 at-

mospheres, and partly because at these temperatures water attacks glass to such an extent that the water becomes quite impure, and the glass becomes almost opaque. Steel was therefore employed in the place of glass, for holding the water under investigation, and the apparatus was also profoundly modified in various other ways, the extreme temperatures and pressures involved requiring special means for their determination. Save for the fact that they were made by the same man, and that the water employed was purified by the same method, Battelli's two series of experiments upon water have almost nothing in common, and we shall follow his own example, by describing them in different articles, devoting the present article exclusively to the consideration of the experiments made at temperatures below 240° C. These experiments (which include all of Battelli's results upon the pressure and density of saturated steam that are of direct importance in practical steam engineering) are given and discussed in his fourth memoir on the properties of vapors, which is entitled "Study of the Vapor of Water with Respect to the Laws of Boyle and of Gay-Lussac" ("Studio del Vapore d'Acqua Rispetto alle Leggi di Boyle e di Gay-Lussac"), and is published in the *Memoirs* of the Royal Academy of Science of Turin, Italy (*Memorie della Reale Accademia delle Scienze di Torino*), Second Series, 1893, Vol. 43, page 63. The apparatus used is not described in this place, however, for it was the same (save in certain unimportant respects) as that used in his previous experiments upon ether, and the description is omitted from the memoir on water, in order to avoid repetition. We therefore take our account of the apparatus itself from his first memoir, which is entitled "Study of the Vapor of Ether with Respect to the Laws of Boyle and of Gay-Lussac" ("Studio del Vapore d'Etere Rispetto alle Leggi di Boyle e di Gay-Lussac"), and is given in the same periodical for 1890, Vol. 40, page 21.

The apparatus used by Battelli may be said, in a general way, to consist of six main parts:—(1) A graduated bulb (called by him the "campanella") of known capacity, containing the water-vapor whose properties were to be studied, and which we shall hereafter call, for the sake of brevity, the "experimental bulb"; (2) a vapor-jacket surrounding the experimental bulb, and serving to heat it to a known temperature; (3) a manometer, or device by means of which the pressure within the experimental bulb could be varied and measured; (4) a little mercury reservoir (the "vaschetta"), serving, among other functions, to connect the experimental bulb with the tube leading to the manometer; (5) a device for increasing the amount of water in the experimental bulb; and (6) a device for determining the precise moment at which the vapor in the experimental bulb begins to condense. With the exception of the manometer and the device for observing the first moment of condensation (to which we shall return subsequently), the apparatus is shown, diagrammatically, in Fig. 1. For various reasons we have not attempted to show it in correct proportion, but we have endeavored to represent it in such a manner that its general features, and its mode of operation, may be understood even more clearly than from the engravings (which are not of the best) given by Battelli in his original memoir.

The experimental bulb, shown at *A*, consisted of a stout glass tube, closed at the top, and fused, at its lower end, to a vertical stem, *B*, about 30 inches in length and nearly $\frac{1}{4}$ in. in internal diameter. The bulb, *A*, was 65 centimeters

(25½ in.) long and 1.7 centimeters (2/3 in.) in diameter, internally, in some of the experiments, and 75 centimeters (29½ in.) long and 2.5 centimeters (1 in.) in diameter, internally, in others. The stem, *B*, terminated in a short tube of substantially the same diameter as the bulb above; and to this enlargement an iron ring, *I*, was securely fastened by means of shellac, or sealing wax (ceralacca), the joint being strengthened by giving the glass tube a slightly conical form, with the widest part downward, or away from the stem *B*. The iron ring, *I*, was threaded on its outer surface, and could be screwed, by means of a special form of wrench, or spanner, into a corresponding thread on the inner surface of a little hollow metal shell or casting, *X*, which constituted the lining of the lower part of the wooden reservoir, *C*.

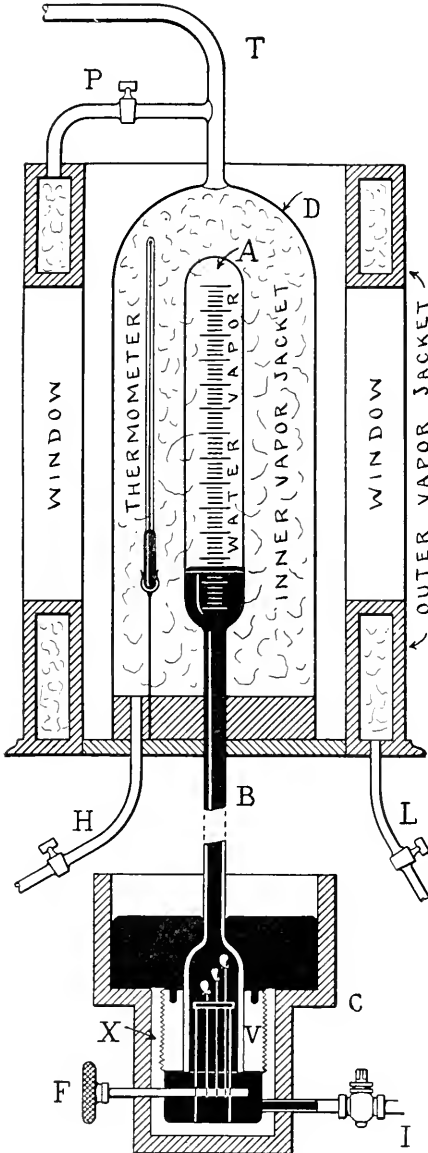

FIG. 1.—THE "EXPERIMENTAL BULB,"
AND ITS ACCESSORIES.

The water-vapor to be studied was enclosed within the experimental bulb, *A*, and confined therein by means of carefully purified mercury, shown black in the illustration; and the experiment consisted in observing the behavior of the water-vapor in *A*, when the space that it occupied was diminished or increased by forcing mercury in through the tube *I*, or by withdrawing it in the same manner, while the vapor in the experimental bulb was kept at a constant temperature.

The temperature of the experimental bulb was controlled by means of the vapor-jacket shown at *D*. This consisted of a glass cylinder, surrounding the experimental bulb for its entire length, and closed at the bottom by a thick stopper. A liquid having (under the ordinary atmospheric pressure) a boiling point suitable for the purpose in view, was caused to boil in a small boiler not shown in the diagram, and its vapor was led into the vapor-jacket, *D*, by means of the tube *H*. At the top of the vapor-jacket was an escape

tube, *T*, which was closed by a stopcock, *P*. The vapor-jacket, *D*, was surrounded by a wooden reservoir, *C*, which was closed at the top by a thick stopper, and had two windows, *W*, for observation. The reservoir, *C*, was lined with a metal shell, *X*, which was fastened to the bottom of the bulb, *A*, by means of an iron ring, *I*, which was threaded on its outer surface, and could be screwed into a corresponding thread on the inner surface of the metal shell, *X*, by means of a special form of wrench, or spanner, *F*.

pipe, *T*, which communicated with a condenser; the condenser being open to the air on the side remote from the apparatus, and serving to condense the vapor used in the jacket, and return it to the boiler. By this means the pressure in the vapor-jacket, *D*, was prevented from becoming materially greater than that of the atmosphere, while at the same time a current of the heating vapor could be passed freely and continuously through the heating jacket, from the boiler to the condenser. The exact temperature of the vapor surrounding the experimental tube was recorded by means of the thermometer shown on the left, the readings of this instrument being taken through the glass vapor-jacket. Corrections were applied to the results for any slight variation that might occur in the temperature during the course of a given experiment, but we cannot enter into an explanation of the way in which these corrections were obtained.

To protect the glass jacket (designated in Fig. 1 as the "inner vapor-jacket") in large measure from loss of heat by radiation, and therefore from the condensation which would otherwise occur and render it impossible to read the thermometer accurately, or to note with precision the position of the mercury in the experimental bulb, the glass vapor-jacket was surrounded by another one of metal, which is designated in the illustration as the "outer vapor-jacket." This outer jacket was in communication with the boiler by means of the tube *L*, and with the condenser, also, by means of the branch tube, *P*, above. It was likewise provided with windows, through which the necessary readings could be taken.

Among the liquids whose vapors were used for filling the heating jacket, *D*, were the following, their approximate boiling points being given in parentheses: Acetone (57° C.), ethyl alcohol (79° C.), water (100° C.), amyl alcohol (130° C.), and aniline (183° C.). Several petroleum distillates were also used, boiling at various temperatures up to 231° C., or 448° Fahr. By a slight modification of the apparatus, too, ice and water, or even freezing mixtures, could be placed around the experimental bulb.

The experimental bulb was graduated, as shown, and was carefully "calibrated" in advance. That is, it was turned upside down, and successive equal weighed quantities of mercury were poured into it, the level of the mercury surface within it being read off, after each addition, from the scale etched upon the surface of the bulb. In this way Battelli ascertained, with precision, the number of cubic centimeters (or cubic inches) of space included between the closed end of the experimental bulb and a mercury surface standing opposite any given mark upon the bulb. Proper account was taken, too, of the volume of the little depression that is always to be seen around the edge of a free surface of mercury, standing in a vessel with vertical sides. The way in which the allowance for this little space was determined is explained at length in the original memoir, the explanation filling three of its generous-sized pages. This part of the work is of much interest, but we cannot describe it, as by so doing we should be led too far away from our main subject.

Battelli took especial and highly commendable pains to ensure the purity of the water with which he experimented. Some three pints of ordinary distilled water were distilled anew over strongly alkaline permanganate of potassium, in a closed glass vessel from which all air had been removed; and the product so obtained was again distilled, in a similar apparatus, over aluminum sulphate. Subsequently the water was subjected to a further distilla-

tion at low temperature, by means of a mercury air pump of the Sprengel type, and collected over mercury. The water so obtained was poured into a glass vessel which had been well washed with nitric acid, water, and boiling alcohol, and was boiled therein for about twenty-four hours. The water prepared in this manner was used in the observations made at temperatures above 100° C. (212° Fahr.). In the experiments made at temperatures below 100° C., the water collected from the distillation by the Sprengel pump was boiled for a long time in a little platinum retort, the neck of which projected upward and was surrounded by a refrigerating mixture. Careful examination of the water as used by Battelli revealed no trace either of carbon dioxide, air, organic substances, or ammonia; and we are of the opinion that so far as the purity of the water is concerned, Battelli's experiments are beyond all criticism.

To introduce water into the space above the mercury in the experimental bulb of his apparatus, Battelli made use of an ingenious device that will be understood by reference to Figs. 1 and 2. He prepared a number of tiny glass phials, of the general shape indicated in Fig. 2. These were pear-like in outline, except that the small end was drawn out into a capillary tip, and curved around into a sort of loop, as indicated at *CA*, in Fig. 2. Each of these

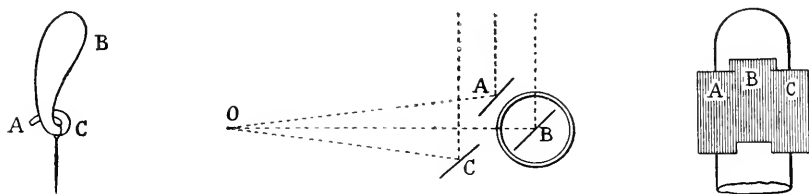

FIG. 2.—WATER PHIAL. FIGS. 3 AND 4.—SHOWING THE ARRANGEMENT OF THE MIRRORS.

tiny phials was weighed while empty, and was then filled with the purified water; and, while its contents were boiling, the phial was sealed up by applying the flame of a blowpipe to its capillary tip (*A*, in Fig. 2). After filling and sealing, the phial was weighed again, and the increase in weight gave the weight of the enclosed water with great accuracy. A silk thread was attached to the loop of each phial, the free ends of the several threads being secured to a cylindrical rod, or axle, which penetrated the base of the reservoir at the bottom of the apparatus, and was provided, externally, with a milled head (or its equivalent), as shown at *F*, in Fig. 1. This part of the preparation was attended to before the experimental tube was placed in position in the apparatus; and it will be understood that with the reservoir, *C* (the references are now to Fig. 1), nearly full of mercury, the little phials of water would float upward, each as far as the length of its thread would allow, into the positions indicated in the engraving. A short distance below the phials was a small, horizontal iron disk (indicated edgewise in Fig. 1), which was supported from the bottom of the reservoir by thin steel wires or rods, and which had a horizontal slot in it, through which the silk threads all passed.

The little phials of water being once in position as indicated, the tips of their capillary ends were broken off by means of delicate nippers; and as the water in the phials was boiling when they were sealed up, and was cold when

the points were nipped off, a tiny quantity of mercury entered the tip of each one, sufficiently to act as an effective plug, or stopper. (That this action really occurred, and that the mercury seal thus obtained was really effective in preventing the escape of water, was verified by preliminary experiments.)

The experimental bulb (heretofore separate from the reservoir, *C*.) was next turned so that its closed end, *A*, was downward, and was completely filled, stem and all, with boiling mercury. (The mercury was boiled to ensure the absence of air from it, and from the experimental bulb.) Its open end was then covered, and the whole was inverted into the mercury in the reservoir, *C*, the valve in the tube *I* being closed. The covering being then removed from the open end of the stem of the experimental tube, the mercury within this tube escaped into the reservoir (leaving a Torricellian vacuum above it), until it had fallen, within the bulb, *A*, and its stem, *B*, to a height above the reservoir corresponding to the normal barometric pressure of the atmosphere. Equilibrium of pressure being thus established, the experimental bulb was next brought into the proper position (its lower end being kept constantly submerged beneath the mercury in the reservoir), and the iron collar, *I'*, was screwed firmly into the casting, *X*; care being taken, of course, that the little floating phials of water entered the base of the stem, *B*, in a proper manner.

By this procedure, Battelli brought the apparatus into the condition shown in Fig. 1, except that the space above the mercury in the experimental bulb was absolutely vacuous, save for such traces of mercury vapor as might rise into it. When he desired to introduce a little water into the upper end of the experimental bulb, he merely turned the milled head, *F*, thereby winding up the silk threads to which the little phials were attached. These threads being purposely made of different lengths, one of the phials (and it was carefully noted and recorded, in advance, *which* one,) would be brought up against the iron disk before the others reached it, and a slight further turn would then cause the thread to break, and the phial, being thereby released, would float upward to the top of the mercury in the experimental bulb, *A*. Upon the application of heat by means of the vapor-jacket, *D*, the water in this phial would expel the mercury plug in the tip, and evaporate into the previously vacuous space. Battelli would then have, in his experimental bulb, a quantity of vapor whose weight was accurately known. And if he desired to increase the quantity of water present, he had only to turn the milled head, *F*, a little further, when a second phial would be brought against the slotted iron disk, have its thread ruptured, and float upward in its turn, just as the first one did.

The thermometry of a research of this character is often its weakest point, and hence it becomes important to scrutinize this element with care, in every case. In the memoir in which Battelli gives his experimental data for water, at temperatures below 240° C., he says nothing about his thermometry, but he states, as already noted, that his apparatus was similar in all respects to that previously employed for ether. Turning to the memoir on ether, we find the following statement: "I made use of three different thermometers; one for low temperatures up to 0° C. [his experiments with ether were carried down to -28° C.], the second for temperatures between 0° and 100° , and the third for temperatures above 100° . The first was graduated in fifths of a degree, and the second and third in tenths of a degree. All three were compared with one another by means of two other thermometers, which in their turn were

compared with the air thermometer; and from time to time the zero of the first and the zero and the 100° point of the second and third were taken." That is all he has to say about his thermometry, and we confess it appears to be a somewhat inadequate account, especially in view of the care with which he has described certain other parts of the work. It will be assumed, in the present series of articles, that the passage quoted above, when taken in connection with Battelli's statement about the similarity of his apparatus for water and for ether, indicates that the temperatures that he gives for water vapor, up to and including 231.41° C., are on the scale of the air thermometer. We could wish that he gave further details about the *kind* of air thermometer with which the comparison was made; but this omission is probably of relatively small importance.

The pressure to which the vapor in the experimental bulb was subjected was measured (and indeed produced) by a gage constructed on the principle of the ordinary mercury column, as employed by Regnault. For temperatures below 100° C., and therefore for pressures within the experimental bulb of less than one atmosphere, absolute, Battelli appears to have used a single column of mercury, just as Regnault did; the diameter of the manometer tube, or gage tube, being then made equal to that of the experimental bulb, so as to avoid errors due to capillarity (that is, errors in pressure due to uncertainty concerning the shape of the curved surface of the mercury in the experimental tube and in the tube of the gage). But for pressures in the experimental bulb exceeding one atmosphere, absolute, Battelli used a gage, or manometer, composed of a series of twenty-one stout glass tubes, each about one centimeter (0.4 in.) in diameter, internally, and $3\frac{1}{2}$ meters ($11\frac{1}{2}$ feet) long, placed in a vertical position, and all in the same plane. These were connected, alternately at the top and bottom, by iron fittings, so that the whole constituted one continuous canal, as will be understood by reference to Fig. 5.

The iron fittings which served to unite the upper ends of the glass tubes of the manometer were provided, at their highest points, with funnels and stopcocks, as indicated at *A, B, C, . . .* in Fig. 5; and the U-shaped fittings which joined the lower ends of the glass tubes were provided with stopcocks, *D, E, F, . . .*, each of which could be so manipulated as to establish free communication between the two adjacent glass tubes, or to isolate these tubes from each other, or to throw them both open to the atmosphere. The tube *I*, in Fig. 5, was continuous with the tube *I* in Fig. 1, so that the manometer was in direct communication with the experimental bulb, when the valve shown in *I*, in Fig. 1, was open.

In order to produce a pressure within the experimental bulb in Fig. 1, the manometer, in Fig. 5, was manipulated as follows: Through the funnel *A*, mercury was poured into the tube *a*. This (always supposing the valve in *I* to be open) would at once give rise, in the experimental bulb, to a pressure the intensity of which could be accurately determined at any moment by noting the height of the mercury column in *a*, with respect to that in the experimental bulb itself. If the pressure that it was desired to produce in the bulb were greater than that which could be realized by filling the column *a* nearly full of mercury, the succeeding tubes of the manometer were brought into service in the following way: The valve in *D* being set so as to give free communication between *a'* and *b*, there was poured into the funnel *B* a quantity of mercury sufficient to effectively seal the bend *D*. Glycerin (or water) was then

introduced through *A* until the tubes *a* and *a'* were filled, and the funnel *A* was also partially filled. It is plain that upon closing the valve associated with *A*, there would be a continuous column of glycerin (or water) between the mercury in *a* and that in *a'*. Communication between *a'* and *b* still being free, mercury was next introduced, as desired, into the tube *b*, by means of the funnel *B*. If the pressure produced in the experimental bulb by filling both *a* and *b* with mercury were still insufficient, the same operation was continued in tube after tube of the manometer, until the desired pressure was attained.

To determine the magnitude of the pressure in the experimental bulb at any given moment, when using this apparatus, it was necessary to know certain things, chief among which were the height of the mercury in the

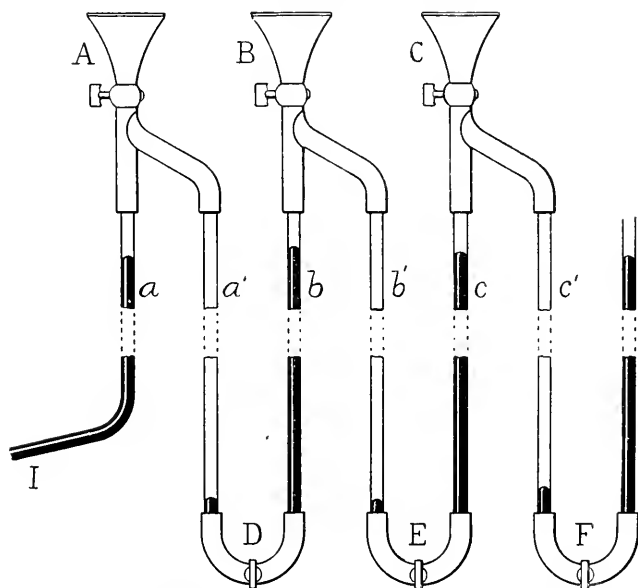

FIG. 5.—THE MERCURIAL PRESSURE GAGE, OR MANOMETER.

experimental bulb itself, the height of the mercury in each of the several tubes of the manometer, the density of the mercury and of the glycerin (or water) used in the manometer, and the barometric pressure of the air in the laboratory. Battelli tells, in full, how all these things were taken into account, so as to obtain an accurate value of the pressure in the bulb in each experiment; but we cannot follow him into the details.

Taking it for granted that the apparatus employed has now been sufficiently described (with the exception of one part, the consideration of which has been purposely deferred), we proceed to show how it was used for determining the pressure and density of saturated steam. It is to be noted, in the first place, that Battelli's apparatus was in one sense a *discontinuous* one, whereas Regnault's was *continuous*. By this we mean that Regnault's apparatus could be used for determining the pressure of saturated steam at any temperature whatever, within the range that he covered; whereas Battelli's apparatus merely enabled him to determine the pressures and densities corresponding to certain particular temperatures within his range,—the temperatures, namely, which

correspond to the boiling points of the substances that were used in the vapor-jackets of Fig. 1. This inherent difference between the two methods must be clearly perceived, if Battelli's method is to be properly understood. The fact that Battelli's method is discontinuous does not imply, however, that it is inferior to Regnault's.

For the sake of definiteness, let us assume that the apparatus shown in Fig. 1 is to be used for determining the pressure of saturated steam corresponding to the temperature 130.20° C. (266.36° Fahr.), this being the boiling point of amyl alcohol, under the ordinary pressure of the air. The boiler that supplies the vapor-jackets is first filled with amyl alcohol, and is then fired up until a steady current of the vapor of this substance has been passing for some time through the jackets, and out through the pipe, *T*, into the condenser. An appropriate (and accurately known) quantity of water having been introduced into the experimental bulb, as already explained, and the temperature of the apparatus having become perfectly steady, the observations are begun under a pressure low enough to permit the water to exist, in the experimental bulb, in the state of superheated vapor. With the apparatus in this condition, the pressure to which the vapor is exposed at some given moment is accurately determined, and the volume that it occupies, in the experimental bulb, is also observed by the aid of the graduation marks on the bulb itself. Then, without permitting the temperature of the apparatus to change, mercury is poured into the manometer, so that the vapor in the experimental bulb, being thereby subjected to a greater pressure, becomes somewhat compressed. The new volume, which the vapor occupies at the new pressure, is then read off, the new pressure being itself recorded at the same time. With the temperature still unchanged, a fresh quantity of mercury is placed in the manometer, and the vapor in the experimental bulb is thereby still further compressed; and so the experiment proceeds. After a time, the temperature still remaining fixed, the pressure reaches a value such that any further attempt to increase it merely results in a marked reduction in the volume of the vapor, accompanied by a corresponding condensation of more or less of the vapor into the liquid form. The vapor has then become saturated, and the pressure at which this marked condensation occurs is the pressure of saturated steam, corresponding to the given temperature at which the experimental bulb has been continuously maintained since the beginning of the work.

To determine the pressure of saturation corresponding to a different temperature, we have to cool the apparatus, and carefully remove all traces of the amyl alcohol from the boiler, the jackets, the piping, and the condenser. A new liquid, having a different boiling point, is then put into the boiler in the place of the amyl alcohol, and a new series of observations is taken, just as before, with varying pressure but constant temperature, culminating with the determination of the pressure of saturation corresponding to the new temperature.

Battelli's method, although quite different from Regnault's, would be classified by the latter as a "statical" method. (See THE LOCOMOTIVE, July, 1906, page 87.) It has the advantage, over either of Regnault's methods, that it gives, not only the *pressure* of saturated steam for a given temperature, but also the *volume* occupied by a unit weight (*i. e.* a unit mass) of steam that is saturated at the given temperature. For, the total weight of the vapor in the experimental bulb being known, and the volume occupied by it being read

off at the moment that saturation occurs, we have merely to divide the observed volume of the vapor at that instant by the known weight (mass) of the enclosed vapor, and we obtain the volume of a unit weight (mass) of the vapor at the saturation point corresponding to the given temperature at which the experiment was performed. Indeed, Battelli's experiments give us much valuable information concerning the properties of steam in the unsaturated, or *superheated*, state, since most of his observations were made while the vapor was still unsaturated. We cannot discuss that aspect of the work, however, in the present article.

It will be seen that the determination of the moment when condensation began was of great importance in Battelli's apparatus; and we have left to the last the description of the highly ingenious device by which he detected the condensation, the instant that it occurred. In the original assembling of the apparatus, and before filling the experimental bulb with mercury, he placed a little mirror of polished steel inside of the top part of the bulb,—namely, at *A*, in Fig. 1. It was held in position by springs which pressed against the inner surface of the bulb, with a force sufficient to ensure the fixity of the mirror during the subsequent manipulation of the apparatus. The mirror was carefully set in such a position that the observer could see in it a brilliant reflection from an artificial light. Outside of the experimental bulb, but near it, two other similar mirrors were placed so that they also gave brilliant reflections from the same source of light; all three mirrors being so situated and adjusted that they appeared, to the observer's eye, to form one continuous surface of uniform brightness. The arrangement will be understood by reference to Figs. 3 and 4, in which *A*, *B*, and *C* are the three little mirrors in question. At the first instant of condensation of the vapor in the experimental bulb, a very thin film of moisture was deposited upon the mirror inside of the bulb, reducing the brilliance of its reflection in a marked manner. The two external mirrors, which were not exposed to the condensation, served as standards of comparison, by the aid of which the observer could readily detect the faintest cloudiness upon the central mirror. It hardly needs to be said that in recording the volume of the vapor in the bulb, Battelli made proper allowance for the volume of the mirror that it contained, and also for the volumes of the glass composing such of the little empty water-phials as might be floating upon the surface of the mercury in the bulb at the time.

Battelli found that the state of the vapor when condensation first begins, and the cloud first forms on the mirror, does not correspond to the state of complete saturation, inasmuch as it is still possible, even after the appearance of the cloudiness, to increase the pressure slightly, before the vapor reaches the state in which reduction of volume, accompanied by condensation, proceeds without any change in pressure. This phenomenon was observed by Regnault, in 1853 or 1854, in connection with a mixture of a vapor and a so-called "permanent gas," such as air. Herwig later found it to hold also in vapors unmixed with such gases, and in this he was confirmed by Willner and Grotrian, and later by Ramsay and Young, and by Battelli. To find what he accepts as the density of fully saturated steam at a given temperature, Battelli adopts a graphical process which may be described briefly as follows: The isothermal line for each given temperature was drawn for the pressures below the pressure of saturation, up to the point where condensation was first noted on the little mirror. He then continued the curve so obtained, until it inter-

sected a line drawn parallel to the axis of temperatures, through the extremity of an ordinate representing the maximum pressure. The density corresponding to the point of intersection so obtained was accepted as the true density of completely saturated steam. As we are now concerned merely with the relation between the pressure and temperature of saturated steam, further discussion of this question of the density of the steam would be out of place in the present article, and must be deferred until we take up the question of density, in a subsequent article. We should not have referred to the density at all, in this place, save for the fact that Battelli's mode of experimentation, being designed to give both pressure and density from the same identical set of observations, made it necessary to do so to a certain extent, in order that his work might be intelligibly presented.

In the accompanying table we give Battelli's general results. The temperatures are expressed on the Centigrade scale, and the pressures are absolute, and are given in millimeters of mercury; each entry in the column of pressures being the height, in millimeters, of a column of mercury which would produce a pressure just equal to the pressure of saturation that was observed. (Battelli says nothing about reducing his pressures to sea-level and to latitude 45° , and hence we assume that the results are given as they were found for his own laboratory.) In the column headed "Volume of Steam" we give, for each temperature, the volume of one gramme of the vapor, expressed in cubic centimeters. All modern measurements of the pressure and density of saturated steam have been made in the metric system, and hence we defer the translation of the results into the English system of units, until the data that are to be used in making out our final table have all been stated. The observed volumes are not given for temperatures below 14.91° C., because Battelli does not give them in his own résumé of general results. He omits them, doubtless, because the total quantity of water present at the lower temperatures was so small that its weight could not be determined with a precision comparable with that obtainable at higher temperatures. The pressures of saturation are not affected by this circumstance.

BATTELLI'S GENERAL RESULTS FOR SATURATED STEAM, BELOW 240° C.

Temperature. (Centigrade.)	Pressure of saturation. (Millimeters.)	Volume of Steam. (C. c. per gramme.)
-6.16°	2.80
+1.32	4.77
6.24	6.87
9.72	8.66
14.91	12.34	80311.4
21.05	18.07	55746.4
27.15	25.96	39534.2
57.01	129.14	8738.90
78.52	330.78	3632.41
99.60	749.12	1690.46
130.32	2060.1	661.534
144.21	3061.9	457.233
182.90	7971.4	187.622
202.21	12181.1	125.379
231.41	21272.1	72.415

Hartford Steam Boiler Inspection and Insurance Company.

ABSTRACT OF STATEMENT, JANUARY 1, 1906.

Capital Stock, \$500,000.00.

ASSETS.

	Par Value.	Market Value.
Cash in office and in Bank,		\$137,832.23
Premiums in course of collection (since Oct. 1, 1905),		201,827.69
Interest accrued on Mortgage Loans,		24,082.58
Loaned on Bond and Mortgage,		952,645.00
Real Estate,		14,690.00
State of Massachusetts Bonds,	\$100,000.00	90,000.00
County, City, and Town Bonds,	368,500.00	383,880.00
Board of Education and School District Bonds,	46,500.00	48,300.00
Drainage and Irrigation Bonds,	5,000.00	5,000.00
Railroad Bonds,	1,231,000.00	1,365,000.00
Street Railway Bonds,	60,000.00	59,150.00
Miscellaneous Bonds,	65,500.00	67,305.00
National Bank Stocks,	41,800.00	57,600.00
Railroad Stocks,	177,800.00	240,909.00
Miscellaneous Stocks,	35,500.00	33,925.00
	\$2,131,600.00	
Total Assets,		\$3,688,146.50

LIABILITIES.

Re-insurance Reserve,		\$1,851,706.33
Losses unadjusted,		34,614.94
Commissions and brokerage,		40,365.54
Surplus,	\$1,261,459.69	
Capital Stock,	500,000.00	
Surplus as regards Policy-holders,	\$1,761,459.69	1,761,459.69
Total Liabilities,		\$3,688,146.50

On December 31, 1905, the HARTFORD STEAM BOILER INSPECTION AND INSURANCE COMPANY had 92,038 steam boilers under insurance.

L. B. BRAINERD, Pres. and Treas. FRANCIS B. ALLEN, Vice-President.
 J. B. PIERCE, Secretary. L. F. MIDDLEBROOK, Asst. Sec'y.
 C. S. BLAKE, Supervising General Agent.
 E. J. MURPHY, M. E., Consulting Engineer.
 F. M. FITCH, Auditor.

BOARD OF DIRECTORS.

FRANK W. CHENEY, Treas. Cheney Brothers Silk Manufacturing Co.	LUCIUS F. ROBINSON, Attorney. Hartford, Conn.
CHARLES M. BEACH, of Beach & Co.	JOHN O. ENDERS, U. S. Bank, Hartford, Conn.
GEORGE BURNHAM, Baldwin Locomotive Wks., Philadelphia.	LYMAN B. BRAINERD, President and Treasurer, Hartford Steam Boiler Inspection and Insurance Co.
C. C. KIMBALL, President Smyth Manufacturing Co., Hartford, Conn.	MORGAN B. BRAINARD, Asst. Treasurer Aetna Life Insurance Co.
PHILIP CORBIN, P. & F. Corbin, New Britain, Ct.	F. B. ALLEN, Vice-Prest. Hartford Steam Boiler Inspection and Insurance Co.
GEORGE A. FAIRFIELD, Ex-Prest. Hartford Machine Screw Co.	CHARLES P. COOLEY, Treas. The Fidelity Company, Hartford, Conn.
J. B. PIERCE, Secretary Hartford Steam Boiler Inspection and Insurance Co.	
ATWOOD COLLINS, Prest. Security Co., Hartford, Conn.	

Incorporated
1866.

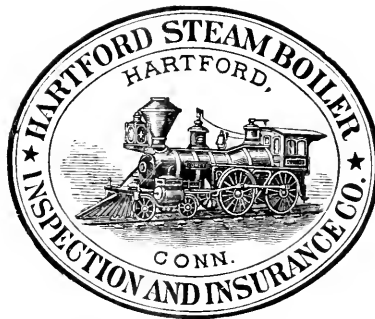

Charter Per-
petual.

The Hartford Steam Boiler Inspection and Insurance Company

ISSUES POLICIES OF INSURANCE COVERING

ALL LOSS OF PROPERTY

AS WELL AS DAMAGE RESULTING FROM

LOSS OF LIFE AND PERSONAL INJURIES DUE TO STEAM BOILER EXPLOSIONS.

*Full information concerning the Company's Operations can be obtained at
any of its Agencies.*

Department.	Representatives.	Offices.
NEW YORK, . . .	C. C. GARDINER, JR., Manager, R. K. McMURRAY, Chief Inspector,	New York City, N. Y., 100 William St.
NORTHEASTERN, . . .	C. E. ROBERTS, Manager, F. S. ALLEN, Chief Inspector,	Boston, Mass., 101 Milk St. Providence, R. I., 29 Weybosset St.
PENNSYLVANIA, . . .	CORBIN & GOODRICH, Gen. Agents, WM. J. FARRAN, Chief Inspector,	Philadelphia, Pa., 432 Walnut St.
MARYLAND, . . .	LAWFORD & MCKIM, Gen. Agents, R. E. MUNRO, Chief Inspector,	Baltimore, Md., 13-14-15 Abell Bldg. Washington, D. C., 511 Eleventh St., N. W.
SOUTHEASTERN, . . .	W. S. HASTIE & SON, Gen. Agts., W. M. FRANCIS, Chief Inspector,	Charleston, S. C., 44 Broad St.
SOUTHERN, . . .	LOUIS V. CLARK & Co., Gen. Agents, H. E. STRINGFELLOW, Chief Inspector,	Birmingham, Ala., 214-216 N. 20th St.
GULF, . . .	PETER F. PESCU, General Agent, R. T. BURWELL, Chief Inspector,	New Orleans, La., 818 Gravier St.
HOME, . . .	E. H. WARNER, General Agent, H. C. LONG, Special Agent, F. H. WILLIAMS, Jr., Special Agent, F. S. ALLEN, Chief Inspector,	Hartford, Conn., 650 Main St.
SOUTHERN CONN.,	W. G. LINEBURGH & SON, Gen. Agts.,	Bridgeport, Conn., 1 Sanford Building.
PITTSBURG, . . .	JAMES W. ARROTT, LTD., Gen. Agt., BENJAMIN FORD, Chief Inspector,	Pittsburg, Pa., 401 Wood Street.
NORTHERN OHIO,	C. A. BURWELL, General Agent, H. A. BAUMHART, Chief Inspector,	Cleveland, Ohio, 337 Superior Ave., N. W.
NORTHWESTERN,	H. M. LEMON, Manager, JAMES L. FOORD, Chief Inspector,	Chicago, Ill., 169 Jackson St.
SOUTHWESTERN,	VICTOR HUGO, Manager, VICTOR HUGO, Chief Inspector,	St. Louis, Mo., 319 North Fourth St.
WESTERN, . . .	THOS. F. DALY, General Agent, T. E. SHEARS, Chief Inspector,	Denver, Col., 210-215 Ta- bor Opera House Bldg.
PACIFIC COAST, . . .	H. R. MANN & Co., General Agents, J. B. WARNER, Chief Inspector,	Oakland, Cal., 464 Tenth St.

The Locomotive

PUBLISHED BY THE HARTFORD STEAM BOILER INSPECTION AND INSURANCE COMPANY.

VOL. XXVI.

HARTFORD, CONN., JANUARY, 1907.

No. 5.

The Lynn Boiler Explosion.

On December 6, 1906, the factory of the P. J. Harney Shoe Company, situated at West Lynn, Mass., was wrecked by the explosion of a boiler, and in the fire which followed, many other buildings in the vicinity were also destroyed. The explosion occurred just before seven o'clock in the morning, when only about a score or so of the hundreds of operatives had entered the building, and owing to this fortunate circumstance there are no deaths to report. Seventeen persons were injured, however, some of the injuries being of a very serious nature.

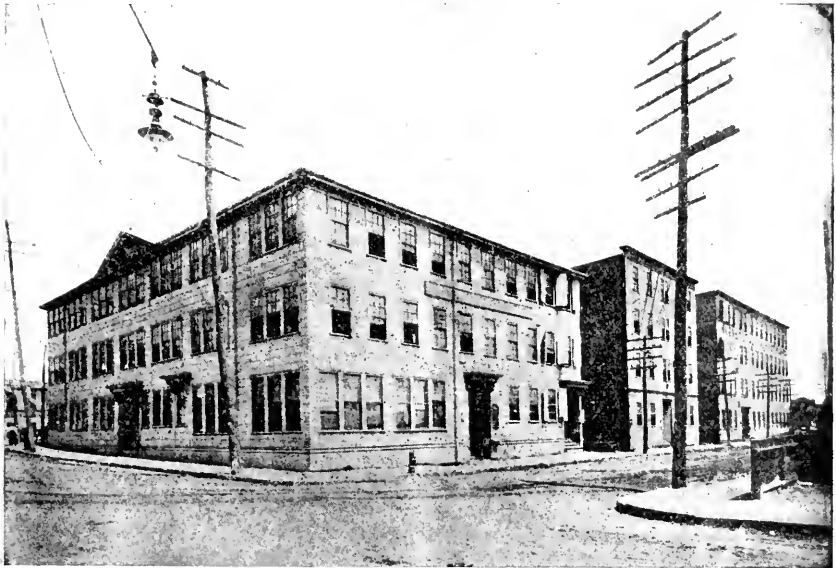

FIG. 1. — THE THREE RUINED FACTORIES, BEFORE THE EXPLOSION.
(The Harney building is on the right.)

One of the accounts that we have received states that "immediately upon the explosion of the boiler, the walls of the Harney building bulged outward, as though they were great sails filled with the wind, and, with a crash and a roar, scattered in all directions." Fire followed at once, and it appears probable that the gas mains in the building were broken by the shock, the liberated gas taking fire and rushing up through the ruins in great volume. Many of the employees who were in the building at the time passed out by way of the fire escapes, but some were forced to jump from the windows into the arms of their fellow workmen on the ground below.

The flames spread almost instantly to the adjoining box factory of John N. Owens, and then to the Tufts & Friedman shoe factory, situated at the corner of Alley and Commercial streets. Fig. 1 shows the appearance of these three buildings before the explosion, the Tufts & Friedman building being in the foreground, the Owens box factory next, and the P. J. Harney factory in the distance. From these buildings the flames spread to many others which lay back of the three buildings shown in Fig. 1. The diagram given in Fig. 2 shows the location of the burned buildings, those that were destroyed by fire being shaded. The small buildings on the Charles street side of the Boston & Maine railroad tracks were mostly dwellings, occupied by families in moderate circumstances. The West Lynn station of the Boston & Maine Railroad took fire almost immediately after the explosion, and little or nothing was saved from it except the tickets, which were hastily removed to a place of safety. The total

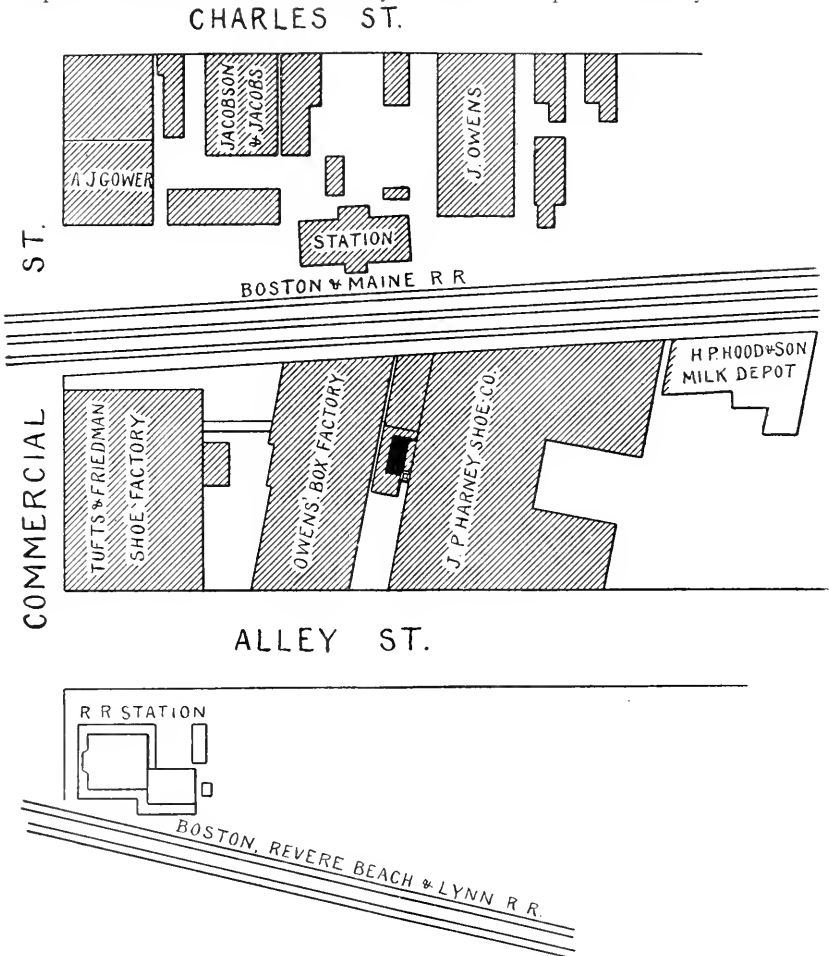

FIG. 2. — LOCATION OF THE BUILDINGS. (Those shown shaded were burned.)

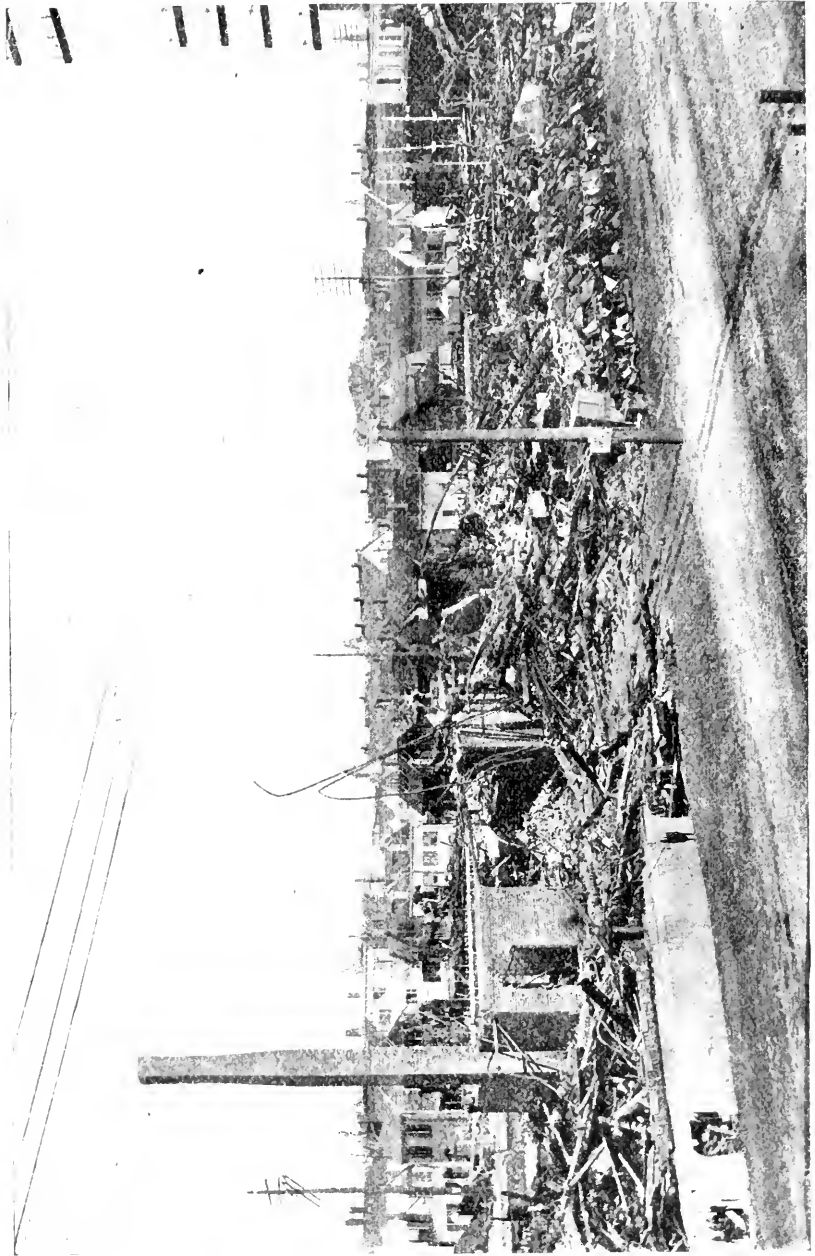

FIG. 3. — GENERAL VIEW OF THE RUINS.

loss, from fire and explosion, is estimated at from \$500,000 to \$600,000; and the immediate loss from the explosion proper, as distinguished from the consequent fire, was estimated at \$18,000.

All three of the factories shown in Fig. 1 were provided with automatic sprinklers, but these were utterly ineffective in the face of the fierce blaze that swept through the buildings. Moreover, the explosion ruptured a four-inch water-main which entered the Harney building near the boiler room, and this reduced the pressure in the street mains to such a degree that the sprinkling systems and the fire department were greatly handicapped. The outside sprinklers on the Tufts & Friedman building were ordered turned on by Chief Harris of the fire department, before the fire reached that building; but they were of little value on account of the reduced pressure.



FIG. 4. — A DETAIL OF THE WRECKAGE.

The location of the boiler which exploded is shown in Fig. 2, by the little black rectangle. The boiler was insured with the Hartford Steam Boiler Inspection and Insurance Company, and was of the horizontal tubular type, the shell consisting of three courses, or rings, each of which was made of a single plate. The shell plates were three-eighths inch thick, and were stamped "Clydebridge Fire-box Steel, 60,000 T. S." The heads were one-half inch thick, and were of steel, bearing the stamp "Central flange." The manhole frame was of cast-iron, of heavy pattern, and was of the internal type, which is recommended by all modern engineers, when cast-iron is used. The boiler contained 92 tubes, each $3\frac{1}{2}$ inches in diameter and 17 feet long, the boiler being of the overhanging front style, 72 inches in diameter and 18 feet 5 inches long. All the tubes were properly beaded at the ends, and the heads were braced with ten

braces to each head, eight of these being through braces, running from one end of the boiler to the other. The feed water was good, and was introduced through the front head in accordance with the approved method of the Hartford Steam Boiler Inspection and Insurance Company; the boiler being provided both with a feed pump and with an injector, either of which was alone competent to feed the boilers satisfactorily. The fusible plug still contained some of its original filling of tin, even after passing through the fire; and this fact shows that the explosion could not have been due to low water. Indeed, its very violence would be sufficient to show that fact, for, as we have repeatedly explained in *THE LOCOMOTIVE*, a low-water explosion is likely to be far less destructive than one in which the boiler contains plenty of water.

Some of the newspapers reported the boiler to be an old one, but this is



FIG. 5. — SHOWING THE TUBES OF THE EXPLODED BOILER.

altogether untrue. It was built in 1895, at the Cunningham Iron Works, South Boston, Mass., and on November 26th of that year it was tested by one of our inspectors, in the shops of the builders, by the application of a hydrostatic pressure of 150 pounds. It has been regularly inspected by us from that date down to the present time, without the discovery of any defect which, in the judgment of the inspector, affected its safety in any way.

The last complete internal inspection of the exploded boiler was made on May 6, 1906, at which time (as the inspectors' written report, submitted to the Harney Company at the time, states), the riveted joints showed no leakage. At this time the steam gage was tested by comparison with a standard gage, and was adjusted so as to conform with the standard gage, which was known to be accurate. The last external inspection of the boiler, made (as is usual) with

the boiler under pressure and subject to the usual working conditions, was made on October 26, 1906, at which time the inspector found that the four-inch "pop" safety-valve worked freely, blowing off at 98 pounds per square inch. The boiler was considered safe for a working pressure of 100 pounds per square inch, and that pressure was allowed in the insurance policy. The regular working pressure was not greatly in excess of 80 pounds, however, and after the last visit of the inspector the valve was set so as to blow off at about 90 pounds. That the safety-valve was in good working condition at the time of the explosion is shown by the fact that it blew off freely, the afternoon before. The machinery was stopped, at that time, on account of the blowing out of an electric fuse; and in the interval required for replacing the fuse, the pressure on the boiler ran up (according to the evidence of the employes) to 90 pounds per square inch, at which pressure the valve blew off, closing again when the pressure had fallen to 89 or 88 pounds. This fortunate circumstance can be considered as demonstrating that at the time of the explosion the safety-valve was neither corroded, nor jammed, nor otherwise rendered inoperative.

The newspapers stated, at the time of the explosion, that cracks were known to exist in the boiler, previous to the explosion, and that the existence of these cracks had been pointed out to the owners. This statement, made without further explanation, was grossly unfair to the Harney Company, because it implied an indifference to safety, on the part of that company; and any implication of that character is utterly unjustifiable by the facts. There is no evidence whatsoever to indicate that the Harney Company had not taken every reasonable care that could have been suggested, to ensure the safety of their boiler. The only basis for the statement concerning the known existence of cracks in the boiler is the following passage from the inspector's report of the examination made on May 6, 1906: "The cast-iron manhole frame shows four cracks from rivet holes to edge; these are not considered serious in present condition, but should be frequently examined to see that they do not extend beyond the rivet holes." Those familiar with steam boilers are well aware that small cracks of this sort are not at all uncommon in manhole frames and along the edges of sheets, and that they rarely result seriously, though (as our inspector stated) they should be watched, to see that they do not manifest a tendency to extend beyond the rivet holes. In the case of the Harney boiler, the manhole frame cracks manifestly had nothing to do with the explosion, for the frame was not torn loose from the sheet by the explosion, nor did any of the lines of fracture enter or pass through the manhole opening, as would necessarily have been the case if the failure had been due, even remotely, to the cracks in the manhole frame. With the one exception here noted, which was trifling and had no bearing upon the explosion, there was no defect known to exist in the boiler, of any sort whatever.

The plates of the shell of this boiler were united by lap joints, the longitudinal joints being double riveted; and an examination of the torn fragments of the boiler indicated that the explosion was due to the development, along the longitudinal joint of the middle course, or ring, of what is known as a "lap-joint crack." This defect was fully discussed in the issue of *THE LOCOMOTIVE* for April, 1905, in connection with the terrible boiler explosion at Brockton, Mass., which was due to a similar cause. In its usual and most dangerous form, the lap-joint crack consists in a fracture of one of the plates of the boiler, following the general course of the riveted joint in such a manner that (as indicated in Fig. 6) it lies very nearly under the extreme edges of the rivet heads, and is at the same time entirely covered by the projecting lap of the unaffected plate.

The main thing to observe in connection with Fig. 6 is that the crack, although it may occur in either the inner or the outer plate of the boiler, always starts from that face of the affected plate which is in contact with the overlapping plate, progressing into the metal more and more deeply until the boiler is weakened perhaps to the point of explosion; and being itself so situated that it cannot be seen from either the inside or the outside of the boiler. It is this peculiarity of position which makes the defect so dangerous, the strength of the plate being sometimes greatly reduced before there is any visible evidence that the crack exists at all. When the crack has perforated the plate at some point, or when it has branches that extend into the affected plate beyond the edge of the overlapping plate, the inspector may reasonably be expected to discover it; but (as too often happens) when neither of these conditions is fulfilled, the detection of a crack of this sort is well-nigh beyond human powers. (For further discussion of this particular defect, and of its causes, the reader should refer to the article cited above.) In his examination on May 6, 1906, the inspector, following the usual practice of our inspectors, carefully examined the plates along the laps of the riveted joints, both internally and externally, for fractures. He could find none, and he reported, in writing, that "the laps of the seams showed no evidences of fractures."

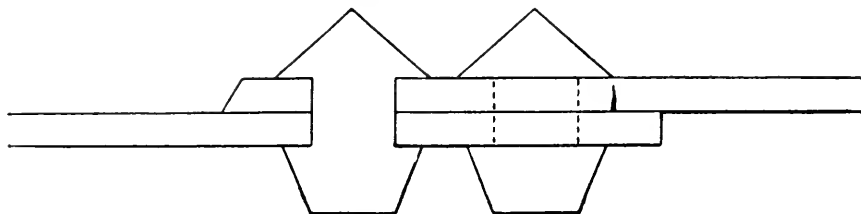

FIG. 6.—A LAP JOINT CRACK UNDER THE OUTER EDGE OF THE RIVET HEADS.

In commenting upon the Lynn explosion (and also upon the previous explosion at Brockton), a number of persons, including some well-known engineers, have suggested that the use of the lap seam be absolutely prohibited by law, the butt joint, which apparently is not liable to similar cracks, being required in its place. This appears to us to be a rather drastic proposition. We should like to see the lap seam discarded altogether, for boilers carrying considerable pressures; but we are aware, at the same time, that the lap joint is regarded by many as entirely satisfactory, when it is well designed and well constructed. At all events, designers of admitted ability continue to make use of it, as they would not do if they were satisfied that it was markedly dangerous. It is probable that 80 per cent. of all the boilers now in use in the United States have lap joints; and the proposition to make the further use of these boilers illegal strikes us as calling for the most serious consideration before acceptance. Certainly there never has been (so far as we are aware) any municipality or state or government, nor any bureau of steam engineering, which has yet made any permanent, wholesale and unqualified condemnation of the lap joint. In view of these facts, it is certainly reasonable to suggest that the matter be most carefully considered before manufacturers and boiler owners generally are put to the enormous expense and inconvenience that would be involved in prohibiting, at once, the use of lap-joint boilers. We are not here pleading for the continued use of the lap joint, but only for reasonableness in any legal enactments that may be contemplated by the legislators of the country.

Inspectors' Reports for January, February, March, and April, 1906.

NATURE OF DEFECTS.	JANUARY.			FEBRUARY.			MARCH.			APRIL.		
	Total defects.	Dangerous.		Total defects.	Dangerous.		Total defects.	Dangerous.		Total defects.	Dangerous.	
Cases of deposit of sediment,	1,434	116		1,258	91		1,390	93		1,866	96	
Cases of incrustation and scale,	3,266	113		2,641	124		2,975	115		3,921	101	
Cases of internal grooving,	191	17		168	27		192	23		268	11	
Cases of internal corrosion,	919	46		792	39		963	46		1,243	52	
Cases of external corrosion,	736	43		612	54		739	39		959	82	
Defective braces and stays,	210	35		152	39		192	64		211	30	
Settings defective,	503	56		382	25		433	60		501	55	
Furnaces out of shape,	587	24		529	23		666	32		763	48	
Fractured plates,	329	59		265	58		296	57		366	34	
Burned plates,	433	48		406	45		447	58		590	52	
Laminated plates,	73	9		65	5		63	6		95	8	
Cases of defective riveting,	285	54		244	64		343	50		468	110	
Defective heads,	133	17		77	14		117	9		135	9	
Leakage around tubes,	989	113		805	114		743	93		1,115	90	
Cases of defective tubes,	529	152		507	162		443	76		867	132	
Tubes too light,	130	29		176	136		136	54		278	46	
Leakage at joints,	510	22		504	43		595	28		597	41	
Water-gages defective,	354	61		238	48		226	50		301	58	
Blow-offs defective,	351	88		268	97		330	81		453	127	
Cases of deficiency of water,	30	13		42	16		44	14		38	15	
Safety-valves overloaded,	125	45		110	22		79	27		90	37	
Safety-valves defective,	119	40		102	43		95	42		114	34	
Pressure gages defective,	658	50		568	39		610	41		671	39	
Without pressure gages,	8	8		22	22		17	17		3	3	
Unclassified defects,	0	0		3	3		0	0		0	0	
Totals,	12,902	1,258		10,996	1,238		11,984	1,175		15,913	1,316	

Inspectors' Reports for May, June, July, and August, 1906.

NATURE OF DEFECTS.	MAY.		JUNE.		JULY.		AUGUST.	
	Total defects	Dangerous.	Total defects.	Dangerous.	Total defects.	Dangerous.	Total defects.	Dangerous.
	Cases of deposit of sediment,	1,707	98	1,621	88	1,707	77	1,573
Cases of incrustation and scale,	3,643	93	3,459	75	3,490	119	3,078	112
Cases of internal grooving,	286	15	274	23	332	36	245	34
Cases of internal corrosion,	1,196	46	1,494	37	1,576	64	1,232	61
Cases of external corrosion,	931	47	1,007	66	1,040	71	892	57
Defective braces and stays,	157	37	178	24	214	38	125	24
Settings defective,	512	45	541	55	617	46	441	42
Furnaces out of shape,	656	26	710	29	821	25	613	43
Fractured plates,	294	37	336	52	297	41	395	49
Burned plates,	488	49	485	47	456	30	593	32
Laminated plates,	88	7	108	9	135	10	90	2
Cases of defective riveting,	215	36	353	114	336	102	250	79
Defective heads,	251	94	134	15	170	21	104	12
Leakage around tubes,	1,168	54	814	135	1,092	200	738	115
Cases of defective tubes,	545	132	526	57	1,084	304	515	297
Tubes too light,	127	26	113	20	362	40	130	26
Leakage at joints,	585	27	415	28	547	17	466	22
Water-gages defective,	212	39	256	54	283	72	250	59
Blow-offs defective,	336	96	350	103	348	104	295	84
Cases of deficiency of water,	30	11	38	19	27	6	22	9
Safety-valves overloaded,	97	35	118	41	95	35	85	13
Safety-valves defective,	104	37	90	32	94	38	109	33
Pressure gages defective,	710	41	546	41	571	38	531	28
Without pressure gages,	4	4	11	11	4	4	14	14
Unclassified defects,	0	0	0	0	6	6	1	1
Totals,	14,342	1,132	13,977	1,219	15,704	1,604	12,497	1,260

Inspectors' Reports for September, October, November, and December.

NATURE OF DEFECTS.	SEPTEMBER.		OCTOBER.		NOVEMBER.		DECEMBER.	
	Total defects.	Dangerous.	Total defects.	Dangerous.	Total defects.	Dangerous.	Total defects.	Dangerous.
	Cases of deposit of sediment,	1,685	81	1,666	127	1,362	80	1,415
Cases of incrustation and scale,	3,198	80	3,173	150	2,971	114	2,938	114
Cases of internal grooving,	176	13	190	19	256	21	189	23
Cases of internal corrosion,	1,010	31	973	32	919	31	850	31
Cases of external corrosion,	848	56	771	58	733	60	817	57
Defective braces and stays,	114	33	155	35	114	20	147	48
Settings defective,	475	41	517	36	434	42	459	49
Furnaces out of shape,	601	32	662	20	589	22	564	28
Fractured plates,	280	49	303	77	241	36	305	58
Burned plates,	403	54	416	47	382	48	433	48
Laminated plates,	72	9	64	8	54	6	71	5
Cases of defective riveting,	262	86	228	28	307	93	321	86
Defective heads,	119	7	129	17	119	13	130	15
Leakage around tubes,	827	110	815	78	959	91	971	108
Cases of defective tubes,	514	91	524	182	537	209	615	178
Tubes too light,	87	21	90	20	108	21	220	47
Leakage at joints,	441	29	387	37	518	28	530	42
Water-gages defective,	246	52	251	57	284	57	289	50
Blow-offs defective,	282	97	342	88	342	107	289	108
Cases of deficiency of water,	44	23	26	7	32	9	49	11
Safety-valves overloaded,	92	35	93	21	99	25	141	44
Safety-valves defective,	107	36	120	37	120	42	110	25
Pressure-gages defective,	485	36	554	43	537	45	512	43
Without pressure-gages,	19	19	16	16	4	4	7	7
Unclassified defects,	0	0	0	0	0	0	0	0
Totals,	12,387	1,121	12,367	1,240	12,021	1,233	12,372	1,320

Summary of Inspectors' Reports for the Year 1906.

During the year 1906 the inspectors of the Hartford Steam Boiler Inspection and Insurance Company made 159,133 visits of inspection, examined 292,977 boilers, inspected 120,416 boilers both internally and externally, subjected 13,250 to hydrostatic pressure, and found 690 unsafe for further use. The whole number of defects reported was 157,462, of which 15,116 were considered dangerous. The usual classification by defects is given below, and a summary by months is given on page 12.

SUMMARY, BY DEFECTS, FOR THE YEAR 1906.

Nature of Defects.	Whole Number.	Dangerous.
Cases of deposit of sediment,	18,624	1,144
Cases of incrustation and scale,	38,753	1,310
Cases of internal grooving,	2,707	262
Cases of internal corrosion,	13,167	516
Cases of external corrosion,	10,085	684
Defective braces and stays,	1,969	433
Settings defective,	5,815	552
Furnaces out of shape,	7,701	352
Fractured plates,	3,617	607
Burned plates,	5,332	558
Laminated plates,	978	84
Cases of defective riveting,	3,612	902
Defective heads,	1,618	243
Leakage around tubes,	11,036	1,381
Cases of defective tubes,	7,266	1,912
Tubes too light,	1,957	371
Leakage at joints,	6,005	364
Water-gages defective,	3,199	666
Blow-offs defective,	3,986	1,180
Cases of deficiency of water,	422	153
Safety-valves overloaded,	1,224	380
Safety-valves defective,	1,246	430
Pressure-gages defective,	6,953	484
Without pressure-gages,	129	129
Unclassified defects,	10	10
Total,	157,462	15,116

COMPARISON OF INSPECTORS' WORK DURING THE YEARS 1905 AND 1906.

	1905.	1906.
Visits of inspection made,	159,561	159,133
Whole number of inspections made,	291,041	292,977
Complete internal inspections,	116,762	120,416
Boilers tested by hydrostatic pressure,	13,266	13,250
Total number of defects discovered,	155,024	157,462
“ “ of dangerous defects,	14,200	15,116
“ “ of boilers condemned,	753	690

SUMMARY BY MONTHS FOR 1906.

MONTH.	Visits of inspection.	Number of boilers examined.	No. inspected internally and externally.	No. tested hydrostatically.	No. condemned.	No. of defects found.	No. of dangerous defects found.
January.	15,249	29,165	9,954	863	75	12,902	1,258
February.	12,822	23,254	7,793	531	39	10,996	1,238
March.	13,566	24,849	8,779	1,015	44	11,984	1,175
April.	12,913	24,765	11,199	1,159	77	15,913	1,316
May.	13,427	24,600	11,008	1,132	45	14,342	1,132
June.	13,157	22,927	11,699	1,198	54	13,977	1,219
July.	13,299	22,849	12,083	1,101	107	15,704	1,604
August.	11,514	21,232	19,473	1,482	54	12,497	1,260
September.	11,792	22,055	19,143	1,319	25	12,387	1,121
October.	13,365	24,783	19,937	973	45	12,367	1,240
November.	14,987	26,689	9,226	1,111	66	12,021	1,233
December.	13,341	25,818	9,012	1,045	56	12,372	1,320
Totals.	159,133	292,977	120,416	13,250	690	157,462	15,116

The following table is also of interest. It shows that our inspectors have made nearly two and a half million visits of inspection, and that they have made nearly four million and three-quarters of inspections, of which more than a million and three-quarters were complete internal inspections. The hydrostatic test has been applied in nearly a quarter of a million cases. Of defects, more than three million have been discovered and pointed out to the owners of the boilers; and more than three hundred thousand of these defects were, in our opinion, dangerous. More than eighteen thousand boilers have been condemned by us as unfit for further service, good and sufficient reasons for the condemnation being given to the assured in every instance.

GRAND TOTAL OF THE INSPECTORS' WORK SINCE THE COMPANY BEGAN BUSINESS,
TO JANUARY 1, 1907.

Visits of inspection made.	2,447,663
Whole number of inspections made.	4,745,414
Complete internal inspections.	1,852,844
Boilers tested by hydrostatic pressure.	237,538
Total number of defects discovered.	3,174,067
Number of dangerous defects discovered.	325,875
Total number of boilers condemned.	18,428

We append, also, a summary of the work of the inspectors of this company from 1870 to 1906, inclusive. The year 1878 is omitted, because the data that we have at hand for that year are not complete. Previous to 1875 it was the custom of the company to publish its reports for the year ending with September 1st, but in that year the custom was changed and the summaries were thereafter made out so as to correspond with the calendar year. The figures given opposite 1875, therefore, are for sixteen months, beginning September 1, 1874, and ending December 31, 1875.

SUMMARY OF INSPECTORS' WORK SINCE 1870.

Year.	Visits of inspection made.	Whole number of boilers inspected.	Complete internal inspections.	Boilers tested by hydrostatic pressure.	Total number of defects discovered.	Total number of dangerous defects discovered.	Boilers condemned.
1870	5,439	10,569	2,585	832	4,686	485	45
1871	6,826	13,476	3,889	1,484	6,253	654	60
1872	10,447	21,066	6,533	2,102	11,176	2,260	155
1873	12,824	24,998	8,511	2,175	11,998	2,892	178
1874	14,368	29,200	9,451	2,078	14,256	3,486	163
1875	22,012	44,763	14,181	3,149	24,040	6,149	210
1876	16,400	34,275	10,669	2,150	16,273	4,275	89
1877	16,204	32,975	11,629	2,367	15,964	3,690	133
1879	17,179	36,169	13,045	2,540	16,238	3,816	246
1880	20,939	41,166	16,010	3,490	21,033	5,444	377
1881	22,412	47,245	17,590	4,286	21,110	5,801	303
1882	25,742	55,679	21,428	4,564	33,690	6,867	478
1883	29,324	60,142	24,403	4,275	40,953	7,472	545
1884	34,048	66,695	24,855	4,180	44,900	7,449	493
1885	37,018	71,334	26,637	4,809	47,230	7,325	449
1886	39,777	77,275	30,868	5,252	71,983	9,960	599
1887	46,761	89,994	36,166	5,741	99,642	11,522	622
1888	51,483	102,314	40,240	6,536	91,567	8,967	426
1889	56,752	110,394	44,563	7,187	105,187	8,420	478
1890	61,750	118,098	49,983	7,207	115,821	9,387	402
1891	71,227	137,741	57,312	7,859	127,609	10,858	526
1892	74,830	148,603	59,883	7,585	120,650	11,705	681
1893	81,904	163,328	66,698	7,861	122,893	12,390	597
1894	94,982	191,932	79,000	7,686	135,021	13,753	595
1895	98,349	190,096	76,744	8,373	144,857	14,556	799
1896	102,911	205,957	78,118	8,187	143,217	12,988	603
1897	105,062	206,657	76,770	7,870	131,192	11,775	588
1898	106,128	208,990	78,349	8,713	130,743	11,727	603
1899	112,464	221,706	85,804	9,371	157,804	12,800	779
1900	122,811	234,805	92,526	10,191	177,113	12,862	782
1901	134,027	254,927	99,885	11,507	187,847	12,614	950
1902	142,006	264,708	105,675	11,726	145,489	13,032	1,004
1903	153,951	293,122	116,643	12,232	147,797	12,394	933
1904	159,553	299,436	117,366	12,971	154,282	13,390	883
1905	159,561	291,041	116,762	13,266	155,024	14,209	753
1906	159,133	292,977	120,416	13,250	157,402	15,116	690

The Locomotive.

A. D. RISTEEN, PH.D., EDITOR.

HARTFORD, JANUARY 15, 1907.

THE LOCOMOTIVE can be obtained free by calling at any of the company's agencies. Subscription price 50 cents per year when mailed from this office. Bound volumes one dollar each. (Any volume can be supplied.)

The Steam Boiler Insurance Field.

Concerning the outlook in the steam boiler insurance business, Mr. L. B. Brainerd, president of the Hartford Steam Boiler Inspection & Insurance Company, has contributed the following article to *Insurance Engineering* for December:

Replying to the request of *Insurance Engineering* for an expression of my views respecting the "outlook in steam boiler insurance, 1907," please permit me to say: I hesitate, in attempting to comply with the request, for fear that, because of the position I occupy, you may consider any views expressed by me as too narrow or too biased for an impartial treatment of the subject, or for the columns of a neutral journal. However, I am convinced, after a brief reflection upon and study of the subject, that the man who writes with any knowledge or breadth of vision concerning the future, or the past history and development of the steam boiler insurance business, must, perforce, write concerning the future and the past history and development of the Hartford Steam Boiler Inspection & Insurance Company. My reasons for this statement will become apparent as I progress.

To approach the subject at once, and make a direct reply, the outlook for steam boiler insurance is not, in my judgment, sufficiently promising to make the field attractive to an underwriter. Nor is it a field capable of any considerable further cultivation or expansion; nor one from which it is now easy to glean a commensurate reward for the employment of the large resources required to carry safely and discharge acceptably the large risks and responsibilities assumed, if the business is to be properly and scientifically conducted.

There are at the present time eleven companies actively and aggressively prosecuting the steam boiler inspection and insurance business in the United States. During the year 1905 these eleven companies collected steam boiler premiums amounting to \$1,922,563.02, of which amount \$1,228,224.66 was paid to one company—the Hartford—and the remaining \$694,338.36 was collected by the remaining ten companies, the amount collected by each company varying between \$3,797.01 and \$334,539.60, and averaging \$69,433.83 for each company.

Assuming that uniform rates per boiler were charged by the various companies, there were at the beginning of this present year 143,577 insured boilers in the United States, of which number 91,727 were carried by one company—the Hartford—and the remaining 51,850 were divided among the remaining ten

companies, the number carried by each company varying between 283 and 24,984, and averaging 5,185 for each company. It is well known, however, that the rates charged by the different companies are not uniform, and, as a question of fact, they vary widely.

The number of boilers carried by the Hartford is a known quantity, and their number is as above stated, and the estimate of the number carried by the other companies can vary only in proportion as their respective rates vary from the rate obtained by the Hartford. If, perchance, their average rate exceeded the Hartford's average rate, it would follow that the number of boilers carried would be correspondingly reduced; and, conversely, if their average rate was less than the Hartford's average rate, the number carried would be correspondingly increased. Likewise, there is scarcely more stability and permanence in policy forms and conditions than there is in rates. A manufacturer today can dictate both rate and policy form, and easily find a company eager to write his business.

There is not any considerable number of insurable boilers uninsured, and this is especially true of boilers used for power purposes and operated under high pressures, and the normal or average increase from year to year of new industries requiring new and additional boilers is not great; so that the chief source or method by which a company must seek to enlarge and build up its business is found in competing for the business now upon the books of some other company; and if secured at all, it is secured, as a rule, at the expense of both rate and service.

The aggregate of premiums collected, the number of boilers insured, and the number of companies competing for the business, indicate clearly the scope and boundaries of this particular branch of casualty insurance — its magnitude and its limitations — and these conditions prevail today, after several years of unprecedented prosperity and expansion in every line of manufacture and industrial endeavor permitting of the use of steam for power, and the consequent demand for, and employment of steam boilers.

This is a brief, concise, and impartial statement of conditions extant today, relating to steam boiler insurance, and any statements or figures that are not taken directly from the sworn reports of the various companies as filed with the insurance departments of the several States in which they operate are the logical and infallible deductions therefrom.

As before stated, the history of the Hartford is the history of steam boiler insurance in this country; and to understand and appreciate the strength and significance of the position now occupied by the Hartford in the field of steam boiler insurance, it will be necessary to refer briefly to its early development, and to its distinguishing characteristics.

The company was organized, and it commenced business, in October, 1866. It was the first company to incorporate in America for the purpose of safeguarding and making practicable the general use of steam for power purposes, and likewise for the scientific construction, installation, and maintenance of steam power plants; and today, after a lapse of forty years, it is the only company which makes a specialty of and does exclusively a steam boiler inspection and insurance business. During its first ten years, or until 1876, it enjoyed a monopoly of the steam boiler inspection and insurance business, as it was without a competitor.

The energy and efforts of the first ten years were spent chiefly in laying the foundation and perfecting an organization with facilities for treating scientifically every component hazard pertaining to the use of steam for power. Comparatively little was accomplished in the way of securing either business or public favor, as at the end of its first ten years of corporate effort it was carrying only 8,796 boilers, was in receipt of an annual premium income of only \$178,000, and in possession of assets amounting to only \$259,000. At this point (1876) competition commenced, and its increase in scope and severity has been apace with the years until at the present time the business of the country is divided among eleven companies.

As a broad principle it must be admitted that our great insurance corporations are under too able management to long extend a protection and render a mechanical service that cost more than they receive. But it is an unfortunate fact in this particular branch of casualty insurance that the character and cost of the service rendered can easily be adjusted to the rate obtained, and without complaint from a steam-user, unless, perchance, he is alert and keen to detect the more rapid deterioration and shorter life service resulting from the lack of frequent and thorough inspections.

There can be no factor pertaining to the operating expense of a steam power plant more expensive than cheap steam boiler insurance; and no cheaper factor than steam boiler insurance sufficiently expensive to provide for regular and thorough inspections of boilers, and so maintain them and the entire steam equipment in a sound physical and safe operating condition.

The test that is being applied today is to determine which company can write at the lowest rate, and allow the highest commission, and extend a breadth of protection the nearest to no limit whatsoever, and remain solvent the longest. In the face of such competition, and not because of its absence, the Hartford has gradually, but steadily, year by year, forged its way to its present commanding position, in which it is caring for, and inspecting, 91,727 boilers, is in receipt of an annual premium income exceeding \$1,200,000 (an amount constituting 64 per cent. of the entire steam boiler premiums paid throughout the United States), and is in possession of assets amounting to nearly \$4,000,000.

It is a conservative estimate that at the present time nine out of every ten insured boilers in the New England States, and about seven out of every ten throughout the United States, are under the care and inspection service of the Hartford. A clearer conception, possibly, of the growth and present magnitude of the company's organization and business may be gained by considering the work performed and the results obtained last year (1905) in its several auxiliary departments, namely:

DEPARTMENT OF CHEMISTRY.

3 analyses of compounds for the purpose of determining their composition, efficacy, and effect upon boilers.

24 analyses of scale or sediment, for the purpose of determining their cause and character, with a view of formulating a remedy.

49 various analyses, submitted by other chemists for verification and approval, relating to the operation of steam power plants.

195 analyses of different waters for the purpose of determining their fitness for use in generating steam, and their effect upon piping and boilers.

DEPARTMENT OF DESIGN AND DRAFTING.

3 plans and specifications covering vulcanizers, bleachers, tanks, etc., chiefly used in rubber and paper manufactories and packing houses.

3 plans and specifications covering brick-hardening cylinders.

13 plans and specifications covering chimneys.

40 plans and specifications covering the setting of boilers.

963 boiler specifications (accompanied with blue-prints) covering design, type, and construction of boilers, especially adapted for the particular purposes desired.

4,954 blue-print plans covering the construction and layout of new steam power plants, or the reconstruction and extension of old ones.

373 plans and specifications (accompanied with blue-prints) covering special cases in which a special or an unusual type of construction was required.

DEPARTMENT OF SUPERVISION AND INSPECTION.

753 boilers were condemned as physically unsafe for further use.

155,024 defects were discovered, of which number 14,209 were considered as vital defects.

291,041 inspections were made, averaging 920 inspections for each work day.

The inspection service maintained is not a "per day" nor a "per boiler" service. The inspection of every boiler, wherever located, and every inspection thereof, is made by a specially instructed, permanently employed, salaried inspector of the company.

The practice of making regular and thorough inspections of boilers was initiated by the incorporators of the company, and it has since been consistently and persistently followed. The idea was based upon the theory that in affording a manufacturer immunity from an explosion a service would be rendered superior even to providing indemnity for a loss, as no consideration of a financial character can compensate for a disaster, in which property and life are involved, that could be averted. Its chief aim, therefore, from the beginning, has been to extend a protection and to render a service which would be worth more than their cost, and which when tested by trial would be recognized as an operating economy and prudentially indispensable.

It is obvious that the primary object of steam boiler insurance is to prevent steam boiler explosions—with the resultant interruption to business, damage to property, and loss of life and injury to persons. In theory there should be no explosions, and, consequently, no losses under a policy providing for the regular inspection and insurance of steam boilers; and there would be none, if inspections were perfectly made, and only perfect material and workmanship entered into their construction, and perfect care and attention were given them by a competent engineer. This result, however, would be ideal, and could be attained only in case all factors entering into the hazard were contributing perfect service.

It should, therefore, be stated, if only as a tribute to the sagacity and foresight of its founders, that, after subjecting the theory to a practical test extending over 40 years, the records of the company show that while its inspection expenses alone have consumed about one-half, or 50 per cent., of the premiums received, its loss ratio has not exceeded 9 per cent; or, stated dif-

ferently, the inspection service of the Hartford has afforded steam-users throughout the past 40 years a protection averaging within 9 per cent. of absolute immunity from explosions—a variation so small as to be well-nigh accounted for by the unavoidable fallibility of men and materials.

This brief history and forecast of the business as it relates to the Hartford would be incomplete and shorn of much of its interest if it did not also contain some indication of the character of its stewardship—the profits realized from the business. In the strife of competition the charge is frequently made that the Hartford has “a monopoly,” and that it is taking “an undue advantage” of its position, and, as we are informed, one of our more ardent and youthful competitors has even gone so far as to charge that we “are actually wasting money upon the frequency of our inspections.” It is, therefore, a pleasure at this opportune moment to acquaint our patrons and the public at large with the results obtained.

During the past five years, 1901 to 1905 inclusive, the company realized an underwriting profit varying between 4 per cent. and 13.78 per cent., and averaging just 7.86 per cent. and no more; and this profit, apportioned per boiler, was equivalent to \$1.06 and no more. It is quite pertinent to ask what manufacturer or what industrial enterprise is conducting so large, so costly, and so hazardous a business, upon so narrow a margin of profit? This is an era and especially is this a year, when unprecedented calamities have demonstrated that the strongest and most prosperous companies are none too properous and strong to promptly meet and fully discharge the great obligations assumed.

The Hartford conducts but one class of business, and its prestige in the field of steam boiler insurance corresponds to that generally attained by all successful specialists. In mechanics, as in surgery and in all the other arts and sciences, the most complete and perfect facilities are employed, the greatest skill is acquired, and the most acceptable service is rendered, by the specialist—the man (or corporation) who gives to one thing all of his time, his entire talent, and his undivided energies.

The amount of steam boiler business done by any one of the other companies constitutes a small and inconsiderable part of their total business—only about 7 per cent. as relating to the company doing the next largest business.

The present age is one in which the tendency is toward large combinations and concentration of control, which conditions require an organization with as complete facilities for the proper conduct of the business in the remote States of the Union as in the industrial centers of New England. Such an organization must be established, and it can be maintained only at great expense.

In conclusion, I can only repeat, but with added emphasis, that I can see in the field of steam boiler insurance no clear and substantial reward for the employment of capital, and no allurements to an underwriter, if, perchance, he seeks an arena for either the exercise of ability or the display of genius.

THE slightly eccentric spelling of the word “through,” in the cut-line on page 100 of our last issue, is not to be construed as a symptom of our conversion to the “new spelling.” We have, indeed, adopted “gage,” and a few other words on the famous list of three hundred; but we don't mean to drop our h's as a general rule.

Boiler Explosions.

SEPTEMBER, 1906.

(277.) — On September 1, at the Toledo Furnace Co.'s plant, Toledo, Ohio, (owned by Pickands, Mather & Co.), the tube-sheet of a water-tube boiler ruptured, necessitating considerable repairs to the boiler, but doing no other damage.

(278.) — A cast-iron header fractured, September 4, in a water-tube boiler at the Hammernill Paper Co.'s plant, Erie, Pa.

(279.) — A tube ruptured, September 4, in a boiler in the Brown-Bonnell plant of the Republic Iron & Steel Co., Youngstown, Ohio. Richard Fleming, Frederick Mumford, T. James, and W. H. Booth were seriously injured, and the furnace was wrecked.

(280.) — On September 6 a tube exploded in a water-tube boiler at the plant of the Western Packing & Provision Co., Chicago, Ill. W. Lawler, an ash-wheeler, was killed.

(281.) — A boiler exploded, September 7, in Calhoun's sawmill, at Jacquet River, N. B. Night watchman Newell McEachern was killed, and the mill, which was rebuilt only three months previously, was wrecked.

(282.) — A boiler exploded, September 7, in Stoemer Bros.' cotton gin and planing mill, Yoakum, Tex. One side of the boiler room was torn out, but nobody was injured.

(283.) — On September 7 a heating boiler exploded in the John M. Smyth school, Thirteenth street and Blue Island avenue, Chicago, Ill. A thousand pupils were in the building at the time, but all reached the street without serious mishap, although several children were slightly bruised. The basement of the building was badly damaged.

(284.) — A tube burst, September 8, in a water-tube boiler at the Marion County power house, Indianapolis, Ind. James Alison was slightly scalded.

(285.) — A boiler exploded, September 8, at the Lewis oil pool, six miles northwest of Lawrenceville, Ill. Six men were injured by the explosion, but all have recovered.

(286.) — A boiler exploded, September 8, in Walter Bryan's sawmill, near Columbia, S. C. W. V. Barfield, John Evans, and Joseph Evans were killed, and a son of Mr. Barfield was seriously injured. Another man, who was driving along the public highway, some distance from the mill, was struck by flying wreckage and slightly injured. The building and machinery were completely demolished.

(287.) — A water-tube boiler exploded, September 9, in the electric lighting plant of the Electric Company of America, Altoona, Pa. The property loss was considerable.

(288.) — On September 12 a slight explosion occurred in the Canton Rubber Co.'s plant, Canton, Ohio.

(289.) — The boiler of a threshing outfit exploded, September 12, on William Pepper's farm, near Edgeley, N. D. The engineer, whose name we have not learned, received injuries which were believed to be fatal. Mr. Pepper was also seriously burned and scalded.

(290.) — Several sections of a cast-iron heating boiler ruptured, September

13, in an apartment house controlled by C. E. Cutting and F. C. Welch, trustees, on Tremont street, Boston, Mass.

(291.) — A boiler exploded, September 13, in Elton Miller's cider mill, two miles from Akron, Ohio. Mr. Miller was killed, and his son was badly burned.

(292.) — A slight explosion occurred, September 13, in the Water Works Pumping Station of the City of Sutton, Neb.

(293.) — On September 13, the boiler of Riley Waters' portable sawmill exploded at Mariba, Menefee county, Ky. John Hale and Ross Byrd were instantly killed. Mrs. Waters and her child, and Miss Dicie Wilson, were also burned so badly that it was believed that they could not recover. The property loss was estimated at from \$2,000 to \$3,000.

(294.) — On September 15 a tube ruptured in a water-tube boiler at the Charleston station of the Boston Elevated Railway Co., Boston, Mass. Michael Collins, a coal-passer, was injured.

(295.) — A tube ruptured, September 15, in a water-tube boiler in the Interstate Iron & Steel Co.'s rolling mill, East Chicago, Ind. John Brown and Joseph Brown, puddlers, were scalded.

(296.) — A boiler exploded, September 17, in the Hazard Rope Works, Wilkesbarre, Pa. Four men, who were on the street or railroad tracks near the plant, were struck by flying wreckage, but none of them was injured seriously. The explosion destroyed the boiler house, and wrecked a large building adjoining. Three dwelling houses, near the works, were also damaged to some extent. George A. Eveland, one of the injured men, subsequently brought suit against the Hazard Manufacturing Co., owners of the exploded boiler, for \$10,000 damages.

(297.) — The boiler of a Pittsburg, Virginia & Charleston freight locomotive exploded, September 17, near Houston Run, four miles from Monongahela, Pa. Engineer Amos Wilhelm and fireman Lawrence Patterson were killed, and conductor T. J. Hogan, flagman Edward Morris, and brakemen Alfred Devore and G. W. Howermer were severely injured. The locomotive and a caboose were destroyed.

(298.) — A boiler belonging to Owen Case exploded, September 17, at Cuyler, N. Y. Millard Hill was seriously burned, and Mr. Case, the owner of the mill, was burned painfully, but less seriously than Mr. Hill.

(299.) — A boiler exploded, September 17, at an ice-house at Port Ewen, N. Y.

(300.) — On September 17 the boiler of a switching locomotive exploded in the yards of the Queen & Crescent system, Chattanooga, Tenn. The fireman received injuries from which it was believed that he could not recover.

(301.) — The boiler of a threshing outfit exploded, September 17, on John Berg's farm, four miles south of Bremen, Ind. Jesse Leeper was instantly killed, and William Porter was fatally injured. Orville Bowser, Wesley Delcamp, and William Montague were also injured seriously, but not fatally.

(302.) — The boiler of a threshing outfit exploded, September 17, on Charles Stiskie's farm, two miles from Carleton, Mich. Nobody was injured, but the machine was totally wrecked.

(303.) — A slight explosion occurred, September 20, in the Central Kentucky Asylum for the Insane, at Lakeland, Ky. Engineer James R. Brucker was scalded.

(304.) — A small boiler, used in connection with a steam mangle, exploded, September 22, in the Ideal Laundry, on Thirty-eighth street, Chicago, Ill. Martha Labuda, Mary Scipono, and Mary Smith were injured.

(305.) — Several cast-iron headers fractured, September 23, in a water-tube boiler at the East Boston Coal Co.'s colliery, Kingston, Pa.

(306.) — A tube ruptured, September 23, in a water-tube boiler at the Wabash Water & Light Co.'s plant, Wabash, Ind.

(307.) — A boiler exploded, September 23, at the plant of the Burt Portland Cement Co., Bellevue, Mich. Frank Lunel was killed, and another man whose name we have not learned was fatally injured. Frank Buell and two Hungarian laborers were also badly scalded.

(308.) — The boiler of a locomotive exploded, September 23, at Ferriday, La. Engineer Lightfoot and four other men were badly injured, but all have since recovered.

(309.) — On September 24 a tube ruptured in a water-tube boiler in the Wm. Cramp & Sons Ship & Engine Building Co.'s plant, Philadelphia, Pa. J. Martin, F. Schalch, and F. Benson were slightly scalded.

(310.) — On September 24 a flue collapsed in a drier used for extracting grease from animal matter, in Armour & Co.'s plant at South Omaha, Neb.

(311.) — A blowoff pipe failed, September 24, in the Sabine Lumber Co.'s plant, Zwolle, La.

(312.) — A boiler exploded, September 25, in Palmanteer & Ellis' bucket factory, Adamsville, Pa. The plant was destroyed, and the property loss was estimated at \$12,000.

(313.) — Several cast-iron headers ruptured, September 26, in a water-tube boiler in the Pressed Steel Car Co.'s plant, McKees Rocks, Pa.

(314.) — On September 28 a tank, used for rendering animal matters, exploded with great violence in the Indianapolis Desiccating Co.'s plant, Indianapolis, Ind. Richard Cox and Daniel Clark were killed, and James Blackwell, William Martin, and Albert Anderson were injured. The buildings on the premises were wrecked, and the property loss was estimated at \$7,500.

(315.) — A blowoff pipe failed, September 29, in the Marion Light & Power Co.'s plant, Marion, Ala. Fireman F. England was injured.

(316.) — The boiler of a threshing outfit exploded, September 29, on the Barnes farm, fifteen miles southwest of Fergus Falls, Minn. Carl Jackson was fatally injured.

(317.) — The boiler of a Santa Fe freight locomotive exploded, September 29, at Pinole, Contra Costa county, Cal. The engineer and fireman were thrown from the cab, but were not seriously injured. The explosion started a grass fire, which nearly destroyed the town of Pinole.

OCTOBER, 1906.

(318.) — On or about October 1, the boiler of a threshing outfit exploded, near Campbell, Minn., fatally injuring Carl Jackson. State Inspector Nelson viewed the wreckage, and concluded that the explosion was due to low water.

(319.) — A boiler exploded, October 2, on Seeler's farm, near Indianapolis, Ind. Two men were injured, and two others were missing at last accounts, and were believed to have been killed.

(320.) — A boiler exploded, October 6, in the Star works of the American Sheet Tin Plate Co., Pittsburg, Pa. Charles Goodwin, Matthew Goodwin, and Patrick McDermott were injured. The exploding boiler passed out through the roof of the building, and landed on the roof of an adjoining mill. We have seen no official estimate of the property loss, but one of the Pittsburg newspapers estimated it at \$5,000.

(321.) — On October 6 a tube ruptured in a water-tube boiler in the power house of the Pascagoula Street Railway & Power Co., Scranton, Miss.

(322.) — A boiler exploded, October 8, in the basement of the apartment building at 6557-6559 Cottage Grove avenue, Chicago, Ill. Fire followed the explosion, and the property loss was about \$1,000. Clinton R. Sherman was severely burned, and Mrs. William Hirsch, living on the second floor, was slightly burned.

(323.) — A tube ruptured in a water-tube boiler, October 8, in the Marion County power house, Indianapolis, Ind.

(324.) — The boiler of a threshing outfit exploded, October 9, on J. P. Hanson's farm, eight miles east of New Richmond, Wis. Peter De Cleen and Lewis Goosen were killed, and C. H. Tucker, Herbert Sewell, B. F. Brott, Nelson Melby, and Elmer Skargem were injured.

(325.) — A boiler used for operating a steam press exploded, October 9, in the Passaic Silk Mill, 44 Tuers avenue, Jersey City, N. J. William Schmidt was badly injured.

(326.) — A boiler used in connection with an oil well exploded, October 9, near Wellington, Kans.

(327.) — A slight explosion occurred, October 10, in the hosiery mill of the Black Diamond Knit Mills Co., Nanticoke, Pa.

(328.) — A stop-valve ruptured, October 10, in the gas plant of the New Orleans Gas Light Co., New Orleans, La.

(329.) — The boiler of a Southwestern freight locomotive exploded, October 10, nine miles north of Alamogordo, N. Mex. Engineer Frederick N. Dobbin and fireman T. E. Brandon were killed, and head brakeman C. O. Gallagher was seriously injured.

(330.) — On October 10 a boiler exploded at Hoist No. 5, of the Rogers Sand Co., Pittsburg, Pa. The property loss was estimated at \$2,000.

(331.) — A tube ruptured, October 11, in a water-tube boiler in the plant of the Adolph Leitelt Iron Works Co., Grand Rapids, Mich.

(332.) — The boiler of a threshing outfit exploded, October 11, on M. F. Murphy's farm, near Manvel, N. D. Fireman Pascal Bushaw was terribly bruised.

(333.) — A boiler exploded, October 11, in the Smith cane mill, at Mentone, Ind. The property loss was small.

(334.) — On October 11, a number of headers fractured, and a tube ruptured, in a water-tube boiler in the plant of the Charleston Consolidated Railway, Gas & Electric Co., Charleston, S. C.

(335.) — A boiler used for steam heating exploded, October 11, in the residence of M. T. Howley, Scranton, Pa. Mrs. Howley was injured so badly that she died on the following day. Peter Howley, Jr. (a six-year old son of the dead woman), and Miss Laura Jones, were also fearfully injured, and at last accounts the hospital authorities considered their recovery doubtful.

(336.)—A boiler exploded, October 11, in Harvey McFarland's sawmill, three miles east of Griffithville, White county, Ark. William Mason, George Mulherrin, and Owen Maxwell were instantly killed. Harvey McFarland (owner of the mill) and John McFarland died three or four hours later, and Robert White was scalded so badly that he died four days later. The mill was demolished.

(337.)—A cast-iron section fractured, October 12, in a boiler in Bradlee & Co.'s chain works, Philadelphia, Pa.

(338.)—A heating boiler exploded, October 12, in the graded school building at Monterey, Pa. The pupils were badly frightened, but there was no panic. The building was badly damaged.

(339.)—The boiler of a threshing outfit exploded, October 12, on L. W. Warner's farm, at Groveland, N. Y. William Tecter was instantly killed, and Frank Pryor was injured seriously and perhaps fatally.

(340.)—On October 13 a boiler exploded on the Government pumping boat *Slackwater*, at Lock No. 4, on the Ohio river, at Legionville, near Beaver, Pa. John Brady, Steven Sutel, Joseph Cooper, and Clifford Norris were killed, and John Weatherland, Clayton Campbell, George Gilchrist, John Rogers, and an unknown man, were injured. Two other men were also missing at last accounts, and these may have been injured. An inquest was held by Coroner J. S. Wade, of New Brighton, the verdict being that the explosion was due to negligence on the part of the United States Government, on the ground, apparently, that the exploded boiler did not receive proper inspection after repairs had been made upon it.

(341.)—A heating boiler exploded, October 14, in the basement of the Dubbs Memorial Church, at Allentown, Pa. Jacob Edelman, janitor, was severely scalded, and the property loss was estimated at \$400.

(342.)—A boiler explosion occurred, October 14, on Frederick G. Bourne's steam yacht *Colonia*, in Oyster Bay Cove, L. I. Albert E. Hip, Edward McGenty, and John Southard were scalded so badly that they died shortly after removal to the Nassau Hospital. John Leonard and James O'Hara were also injured seriously, but not fatally. During 1905 the *Colonia* was flagship of the New York Yacht Club, of which Mr. Bourne was then commodore.

(343.)—On October 15 a slight explosion occurred in the Electric Light Plant of the Borough of Madison, Madison, N. J.

(344.)—The boiler of locomotive No. 1519, on the Reading railway, exploded, October 15, at Lebanon, Pa. Engineer Frank Brown was seriously injured, and fireman Harry Hollenbach and conductor George Booth received minor injuries. The locomotive was completely wrecked.

(345.)—A small boiler, used by the Fort Schuyler Construction Co. for driving wells in the excavation work for the pipe line of the Consolidated Water Co., exploded, October 15, at Hincley, N. Y. Nicholas Ariganillo was killed, and Thomas Sicco and Thomas Spat were injured.

(346.)—On October 15 a boiler exploded in Frank Gosnell's sawmill, at Pinkstaff, Ill., near Vincennes, Ind. Frank Gosnell, Jr. (owner), and George Groves were killed, and Edward Gosnell, Philip Groves, and Willard Wells were injured. The mill was destroyed.

(347.)—A boiler exploded, October 17, in Bedford Blackman's sawmill, in Orchard township, near Fairfield, Ill. Zephaniah Cunningham, Washington

Byars, and Charles Holleman were injured, and it was thought that Cunningham might not recover. The mill was demolished.

(348.)—A boiler exploded, October 17, at Butte, Mont. Frank Gravelin was killed. We have not learned further particulars.

(349.)—The crown sheet of a Lake Shore locomotive blew out, October 22, at South Bend, Ind. Fireman Victor Trudeau and engineer Molehouse were injured so seriously that at last accounts it was thought that they could not recover.

(350.)—The boiler of a corn-husking outfit exploded, October 22, on Frank Robinson's farm, in Burton township, near Flint, Mich. Mr. Robinson was seriously injured.

(351.)—A tube ruptured, October 23, in a water-tube boiler at the plant of the Public Service Corporation of New Jersey, Hackensack, N. J. (See the next item.)

(352.)—A tube ruptured, October 23, at the plant of the Public Service Corporation of New Jersey, Hackensack, N. J. (Compare the last item. These two explosions were distinct, and occurred in different boilers.)

(353.)—A slight explosion occurred, October 24, in the Richmond Power & Light Co.'s plant, at Livingston, Staten Island, N. Y. John Thompson and William Smith were fatally injured, and Cornelius Sweeney and Dennis Donovan received injuries which were serious, and perhaps fatal.

(354.)—The boiler of a freight locomotive exploded, October 24, on the Chicago, Milwaukee & St. Paul railway, at Morton Grove, Ill. Fireman J. Dougherty was killed instantly, and engineer Henry Klumb was fatally injured. Prakeman W. L. Grass was also injured seriously, but not fatally. The locomotive was practically destroyed, and the first seven cars of the train were overturned on the roadbed.

(355.)—On October 25 a tube ruptured in a water-tube boiler in the Marion County power plant, Indianapolis, Ind.

(356.)—The crown-sheet of a Northern Pacific locomotive failed, October 26, at Belfield, twenty miles west of Dickinson, N. D. Brakeman Frank Cunningham was injured so badly that he died on the following day. Conductor Hogue and fireman Louis Fried were also injured, but will recover.

(357.)—A slight explosion occurred, October 26, in the Pejepscot Paper Co.'s plant, Pejepscot, Me.

(358.)—A boiler belonging to Charles Core, and used in drilling for oil, exploded, October 27, on the C. H. Campbell farm, near Merlin, Ont.

(359.)—A slight explosion occurred, October 27, in the Insulated Wire factory, at De Kalb, Ill.

(360.)—A boiler exploded, October 30, in a sugar house on Shell Hill plantation, near Vacherie, La. Alexander Stein, Augustin Falgoust, Charles Ockman, Stephanie Falgoust, and Joseph Martinez were scalded to death.

(361.)—On October 31 a tube pulled out of the shell of a water-tube boiler at the Interstate Iron & Steel Co.'s plant, East Chicago, Ind. John Cleary and Joseph Hooks were injured.

NOVEMBER, 1906.

(362.)—On November 1 a stop-valve ruptured in the plant of the Electric Company of America, Auburn, N. Y. Thomas J. Conroy, who was opening the valve at the time, was injured.

(363.)—A tube ruptured, November 1, in a water-tube boiler at the Auditorium Hotel, Chicago, Ill. Patrick Stack, water-tender, was injured.

(364.)—A boiler exploded, November 3, at the American Palace Steam Laundry, Fargo avenue, Buffalo, N. Y. Joseph Swietzer and Elisha Simpson were killed outright, and Thomas McClune and Arthur Smith were injured so badly that they died, subsequently, at the Emergency Hospital. The brick boiler house in which the explosion occurred was demolished. The total property loss was estimated at \$30,000. We judge, from the report of the local experts who examined the ruins, that the explosion was due to a "lap-joint crack." (For a description of this kind of defect, see THE LOCOMOTIVE for April, 1905, page 159.)

(365.)—On November 4 a slight rupture occurred in a boiler at S. Rawitser & Co.'s woolen mill, Hope Valley, R. I.

(366.)—A boiler used for heating water exploded, November 4, in George Moore's Turkish bath establishment, 87 Central street, Kansas City, Mo. Charles Kubach was injured. The property loss was about \$1,000.

(367.)—On November 5 a blowoff pipe failed at the greenhouses of W. J. Dana, Wellesley Hills, Mass. The direct damage was small, but the indirect loss, due to the lowering of the temperature of the greenhouses, was estimated at about \$1,000.

(368.)—A boiler exploded, November 5, in the power station on the Thomas Hayes oil lease, three miles from Marion, Ind.

(369.)—A boiler ruptured, November 5, in A. L. Hoover & Son's hotel, Lincoln, Neb. (See also No. 393, below.)

(370.)—The boiler of a locomotive exploded, November 6, at Scalp Level, Pa. Firemen Frank Storey and James Hannan, conductor George Robinson, and engineer James Brannigan were injured. The property loss was estimated at \$5,000.

(371.)—A tube ruptured, November 6, in a water-tube boiler at the Knoxville Cotton Mills, Knoxville, Tenn. Fireman Robert B. King was scalded.

(372.)—A boiler ruptured, November 7, in the Fiskdale Cotton Mills, Fiskdale, Mass.

(373.)—A tube ruptured, November 8, in a water-tube boiler at the plant of the S. O. & C. Co., Ansonia, Conn.

(374.)—On November 9 a tube ruptured in a water-tube boiler in the power house of the Kokomo, Marion & Western Traction Co., Kokomo, Ind.

(375.)—On November 9 a tube pulled out of the tube-sheet of a water-tube boiler at the plant of the New York Belting & Packing Co., Passaic, N. J.

(376.)—Several cast-iron headers fractured, November 10, in the plant of the By-Products Coke Corporation, South Chicago, Ill.

(377.)—On November 11 the boiler of the locomotive drawing the Southern Pacific railway's "Sunset Limited" express exploded at Sargent's Station, on the Coast Line railway, 39 miles south of San Jose, Cal. Engineer Edward Gillespie and Thomas Goodfellow were killed, and fireman Mark Glavin was fatally injured. A. P. Pollard and F. Weinmann were also seriously burned and bruised. The locomotive was completely demolished, and fragments of it were thrown to a distance of 500 feet.

(378.)—On November 11 a stop-valve ruptured at the plant of the McCullough Iron Co., Wilmington, Del. Fireman David Richards, who was opening the valve at the time, was injured.

(379.)—A boiler exploded, November 12, in the Lake Shore railway's power-house at Collinwood, a suburb of Cleveland, Ohio. Max Crawford, Albert Bloom, A. P. Latte, Paulo Lancioni, Giovanni Pacioni, and Julius Maeder were killed, and Frederick Kergan, Frank Evans, W. A. Davis, R. D. Fildes, Frank Abbott, James Melger, Lorenz Mermick, Lagenia Amilcare, and Licinio Palemere were injured. At last accounts it was believed that Davis and Kergan could not recover. The men that were killed and injured were working close to the exploded boiler, laying the foundation for a dynamo.

(380.)—A boiler used for heating water exploded, November 13, in the basement of a new six-story apartment house at 137 West 132d street, New York City. The building was unoccupied at the time.

(381.)—A boiler exploded, November 15, in the Hartford Building, Madison and Dearborn streets, Chicago, Ill. A small panic followed among the occupants of the building, but nobody was seriously injured.

(382.)—On November 15 a cast-iron mud-drum, attached to a water-tube boiler, exploded in the Auditorium Hotel, Chicago, Ill.

(383.)—A boiler exploded, November 15, in a cotton gin at Caulksville, Ark., on the Arkansas Central railway. John Gilbert (owner of the gin), George Marshall, Charles White, and William Bell were killed, and some twenty others were injured.

(384.)—A heating boiler exploded, November 16, in the Franklin Public School building, Rahway, N. J. There was no panic, the pupils filing out quietly upon the sounding of the fire-drill signal.

(385.)—On November 17 a boiler exploded at the plant of the Casparis Stone Co., Marble Cliff, near Columbus, Ohio.

(386.)—A boiler exploded, November 17, in D. P. Miller's sawmill, on Negro Mountain, Elk Lick, Pa., near Cumberland, Md. John Tressler and a son of the owner of the mill were injured, and the mill was badly wrecked.

(387.)—The Canadian steamer *Thcano* was wrecked, November 17, in Thunder Bay, Lake Superior, and the crew was obliged to take to the lifeboats. A few moments after they abandoned the *Thcano*, her boilers exploded, and the shattered hull slid into deep water. Part of the crew reached Port Arthur, Ont., after a struggle lasting half a day, and the remaining members were picked up by another steamer.

(388.)—On or about November 20 a boiler exploded at an oil well near Elk City, Okla. Morris Dunlave was seriously injured.

(389.)—On November 20 a tube ruptured in a water-tube boiler at the Standard Ice Manufacturing Co.'s plant, Philadelphia, Pa. Fireman Edward Fahey was scalded.

(390.)—A steam-heating boiler exploded, on or about November 21, at Texarkana, Ark.

(391.)—A blowoff pipe failed, November 21, at the Patchogue Manufacturing Co.'s plant, Patchogue, N. Y. Fireman Sidney Girard was burned.

(392.)—A boiler exploded, November 21, at the Jerry Morrow mine, near Wellston, Ohio. Engineer John Dunfee was seriously burned.

(393.)—On November 22 a rupture occurred on a boiler in A. L. Hoover & Son's hotel, Lincoln, Neb. (See also No. 369, above. The accident recorded in the present item consisted in the failure, through accumulation of scale, of the patch which was put on in repairing the first rupture.)

(394.) — On November 23, a tube ruptured in a boiler at Toledo, Ohio, in the Toledo Furnace Co.'s plant, owned by Pickands, Mather & Co.

(395.) — A boiler exploded, November 24, near South River, about twelve miles from Salisbury, N. C. Thomas Park was injured so badly that he died a few days later. Two other men whose names we have not learned were also injured, though both will recover.

(396.) — A boiler exploded, November 24, in the Central Pennsylvania Light & Power Co.'s power plant at Clearfield, Pa. Engineer George Beyer was injured so badly that he died some ten days later. The power company's plant was damaged to the extent of about \$8,000. George W. Smith's three-storied grist mill, adjoining the power house, was also completely wrecked, Mr. Smith's loss being estimated at \$20,000.

(397.) — The boiler of a Chicago & Eastern Illinois locomotive exploded, November 25, at Knob View, Mo., on the St. Louis & San Francisco railway. Engineer Earl M. Joslyn was instantly killed, and brakeman Thomas P. Roach received injuries which may prove fatal.

(398.) — A slight rupture occurred, November 26, in a boiler at the Franz Brothers Packing Co.'s plant, Springfield, Ill.

(399.) — A traction engine boiler exploded, November 26, on a public highway near Litchfield, Ill. Frederick Watkins received injuries which will probably prove fatal.

(400.) — A boiler exploded, on or about November 27, at Dense Run, Marion county, W. Va. John Shriver, Jr., was killed. We have not learned further particulars.

(401.) — On November 27 a tube ruptured in a water-tube boiler in the Marion County power-plant, Indianapolis, Ind. (See No. 403, below.)

(402.) — A tube ruptured, November 28, in a water-tube boiler at the Minter City Oil Mill, Minter City, Miss. Fireman Oliver Duke was injured.

(403.) — On November 29 a tube ruptured in a water-tube boiler at the Marion County power-plant, Indianapolis, Ind. (See also No. 401, above. The two accidents were distinct, and the bursted tubes were on different boilers.)

(404.) — On November 29 a cast-iron header fractured in a water-tube boiler in the Young Men's Christian Association, Buffalo, N. Y.

(405.) — The boiler of Jameson's sawmill exploded, November 29th, at Paddy's Run, near Renovo, Pa. Engineer Robert Probst was fatally injured, and died within a few hours. P. H. Buck was also painfully hurt.

DECEMBER, 1906.

(406.) — A small boiler, used for tempering wheat, exploded, December 4, in the Pioneer Mill, owned by Frank Bacon, at Tiffin, Ohio.

(407.) — On December 4, a blowoff pipe failed on a boiler situated in a building occupied by the Domestic Manufacturing Co. and the Eureka Laundry, at Coshocton, Ohio.

(408.) — A small boiler used for heating water exploded, December 5, at St. John's Hospital, St. Louis, Mo. The fireman was badly injured.

(409.) — On December 5 a boiler used for operating a corn-husking machine exploded on Samuel Whitney's farm, in the town of Rosendale, three miles south of Pickett, Wis. The boiler was blown to pieces, but nobody was seriously injured.

(410.) — A blow-off pipe ruptured, December 5, in Stone & Fort's cotton gin, Dunleath, Miss.

(411.) — A boiler exploded, December 6, in the P. J. Harney Shoe Co.'s plant, Lynn, Mass. Seventeen persons were more or less seriously injured, but fortunately nobody was killed. The property loss due immediately to the explosion of the boiler was estimated at \$18,000. The ruins of the building took fire immediately, however, and the flames destroyed many buildings in the vicinity, so that the total property loss, from explosion and fire jointly, was nearly \$600,000. An illustrated account of this explosion is given elsewhere in the present issue.

(412.) — The boiler of a locomotive exploded, December 7, on the Canadian Pacific railway, near Winnipeg, Man. Fireman George Conley was fatally scalded, and Fireman Backus was injured severely but not fatally. The explosion consisted in the failure of the crown sheet.

(413.) — On December 9, a slight accident occurred to a boiler at Berea College, Berea, Ky.

(414.) — A boiler, used for operating steam drills, exploded, December 13, in the Alleghany Coal & Iron Co.'s quarry, at Bells Valley, Augusta County, Va. Richard Zimbardo was instantly killed, and Boyd Agner was injured so badly that he died a few days later. Samuel Vest was also painfully burned.

(415.) — A boiler explosion occurred, December 15, in A. A. Gast's new electric lighting plant at Akron, ten miles east of Rochester, Ind. Thomas Gast (son of the owner of the plant) was injured so badly that he died within a few hours, and James Thrush was scalded seriously but not fatally. (The explosion appears to have consisted in the failure of the blow-off pipe, or its fittings.)

(416.) — A blow-off pipe ruptured, December 17, in the Mohr Brothers' Laundry Co.'s plant, Pittsburg, Pa. Harry Nesbit was scalded about the hands and feet.

(417.) — A boiler used for steam heating exploded, December 19, in Ferdinand Benedict's residence on Lafayette avenue, Passaic, N. J. The house and its contents were seriously damaged, the property loss being estimated at \$1,000.

(418.) — On December 19, a boiler exploded on the Mississippi river steamer, *W. T. Scovell*, plying in the Vicksburg and Davis Bend trade, while loading freight at Gold Dust Landing, seventeen miles south of Vicksburg, Miss. Capt. John A. Quackenboss (master of the boat), Wade Quackenboss, Laval Yerger, Joseph Smith, Mack Clarke, John Clarke, and two roustabouts and eight deck passengers, whose names we have not learned, were killed. Some fifteen other persons were also injured, and the boat was destroyed.

(419.) — On December 20, a tube ruptured in a water-tube boiler in the National Home for Disabled Volunteer Soldiers, at Danville, Ill.

(420.) — Two work-train locomotives collided, December 20, on the tracks of the New York Contracting Co., at Eleventh avenue and Thirty-second street, New York City; and as the result of the collision, the boiler of one of the locomotives exploded. Anthony Brennan, engineer of the exploded locomotive, was bruised and scalded.

(421.) — On December 21, a blow-off pipe ruptured in the Studley Box & Lumber Co.'s plant, Rochester, N. H. Woodbury Blaisdell, Charles Brown, and Maynard Wallingford were scalded.

(422.) — A boiler used to operate a corn-shelling machine exploded, on or about December 22, in Morris Township, some twenty miles southwest of

Wellington, Kan. Edward Cowell was instantly killed, and his brother, J. C. Cowell, was badly injured, but will recover.

(423.) — A boiler exploded, December 24, in the Central City Brass Co.'s plant, Syracuse, N. Y. Engineer James Taffner was slightly injured, and the property loss was estimated at \$1,000.

(424.) — Several cast-iron headers ruptured, December 26, in a water-tube boiler at the Glenwood power house of the Baltimore & Ohio Railway Co., Glenwood, Pa.

(425.) — On December 27, a boiler exploded in the Brewster Coal Co.'s plant, near Waynesburg, Ohio. The boiler house was destroyed, and the property loss was estimated at \$6,000.

(426.) — A boiler exploded, December 28, in the plant of the Freedom Oil Co. (a subsidiary of the Standard), at Wheeling, West Va. Fire followed the explosion, and the plant was destroyed with a loss estimated at \$10,000.

(427.) — A boiler exploded, on or about December 31, in a cement factory at Stroh, Lagrange County, Ind.

(428.) — The boiler of a West Jersey & Seashore locomotive exploded, December 31, at Pitman Grove, N. J. Engineer Daniel C. Hand, Albert Johnson, and John H. Lake, were seriously injured, and the locomotive was destroyed.

Boiler Explosions During 1906.

We present, herewith, our usual annual summary of boiler explosions, giving a tabulated statement of the number of explosions that have occurred in the United States (and adjacent parts of Canada and Mexico) during the year 1906, together with the number of persons killed and injured by them. As we have repeatedly explained, it is difficult to make out accurate lists of boiler explosions, because the accounts that we receive are not always satisfactory; but, as usual, we have taken great pains to make the present summary as nearly correct as possible. It is based upon the monthly lists that have been published in *THE LOCOMOTIVE* during the past year; and in making out these lists it is our custom to obtain several different accounts of each explosion, and then to compare these accounts diligently, in order that the general facts may be stated with a considerable degree of accuracy. We have striven to include all the explosions that have occurred during 1906, but it is quite unlikely that we have been entirely successful in this respect, for many accidents have doubtless occurred that have not been noticed in the public press, and many have doubtless escaped the attention of our numerous representatives who furnish the accounts. We are confident, however, that most of the boiler explosions that have attracted any considerable amount of attention are here represented.

The total number of boiler explosions in 1906, according to the best information we have been able to obtain, was 431, which is 19 fewer than were recorded for 1905. There were 450 in 1905, 391 in 1904, 383 in 1903, and 391 in 1902. In several instances during the year 1906 two or more boilers exploded simultaneously. In every case of this sort we have followed our usual practice and counted each boiler separately in making out the summary, believing that by so doing we should represent the actual damage more accurately than we should if we simply recorded the number of separate occasions on which boilers have exploded. We have also omitted from the summary explosions Nos. 71 and 86, for reasons explained on page 101 of our issue for October, 1906.

The number of persons killed in 1906 was 235, against 383 in 1905, 220 in 1904, 293 in 1903, and 304 in 1902; and the number of persons injured in 1906 was 467, against 585 in 1905, 394 in 1904, 522 in 1903, and 529 in 1902.

The average number of persons killed, per explosion, during 1906, was 0.545, and the average number of persons injured but not killed, per explosion, was 1.083.

During the year 1906 there were a number of very serious explosions (see, for example, the explosion at Lynn, Mass., illustrated in the present issue), but none that would compare, in regard to the number of persons killed, with the fearful explosion at Brockton, Mass., in 1905, nor with that on the U. S. gun-boat *Bennington*, in the same year.

SUMMARY OF BOILER EXPLOSIONS FOR 1906.

MONTH.	Number of Explosions.	Persons Killed.	Persons Injured.	Persons Killed and Injured.
January,	53	33	37	70
February,	37	14	26	40
March,	37	19	33	52
April,	38	21	56	77
May,	28	17	30	47
June,	27	7	18	25
July,	26	12	37	49
August,	33	10	38	48
September,	41	22	50	72
October,	44	35	45	80
November,	44	24	50	74
December,	23	21	47	68
Totals,	431	235	467	702

Obituary.

BENJAMIN M. LORD.

It is with profound regret that we announce the death, on October 21, 1906, of Mr. Benjamin M. Lord, special agent of the Hartford Steam Boiler Inspection and Insurance Company, at Providence, Rhode Island. He was born at Kennebunk, Maine, on May 4, 1832, and was one of the company's oldest representatives, having entered the service on July 4, 1870. He was inspector for twenty years, associated with Mr. John L. Smith, general agent at Providence; and in 1890, upon Mr. Smith's retirement from active business by reason of the infirmities of age, Mr. Lord was made special agent for his territory.

Mr. Lord was a most estimable gentleman. He was faithful and efficient, and had the deepest respect and confidence, not only of the company that employed him, but also of its patrons whom he served, and of the community in which he lived.

Hartford Steam Boiler Inspection and Insurance Company.

ABSTRACT OF STATEMENT, JANUARY 1, 1906.

Capital Stock, \$500,000.00.

ASSETS.

	Par Value.	Market Value.
Cash in office and in Bank,		\$137,832.23
Premiums in course of collection (since Oct. 1, 1905),		201,827.69
Interest accrued on Mortgage Loans,		24,082.58
Loaned on Bond and Mortgage,		952,645.00
Real Estate,		14,690.00
State of Massachusetts Bonds,	\$100,000.00	96,000.00
County, City, and Town Bonds,	368,500.00	383,880.00
Board of Education and School District Bonds,	46,500.00	48,300.00
Drainage and Irrigation Bonds,	5,000.00	5,000.00
Railroad Bonds,	1,231,000.00	1,365,000.00
Street Railway Bonds,	60,000.00	59,150.00
Miscellaneous Bonds,	65,500.00	67,305.00
National Bank Stocks,	41,800.00	57,600.00
Railroad Stocks,	177,800.00	240,909.00
Miscellaneous Stocks,	35,500.00	33,925.00
	\$2,131,600.00	
Total Assets,		\$3,688,146.50

LIABILITIES.

Re-insurance Reserve,		\$1,851,706.33
Losses unadjusted,		34,614.94
Commissions and brokerage,		40,365.54
Surplus,	\$1,261,459.69	
Capital Stock,	500,000.00	
Surplus as regards Policy-holders,	\$1,761,459.69	1,761,459.69
Total Liabilities,		\$3,688,146.50

On December 31, 1905, the HARTFORD STEAM BOILER INSPECTION AND INSURANCE COMPANY had 92,038 steam boilers under insurance.

L. B. BRAINERD, Pres. and Treas. FRANCIS B. ALLEN, Vice-President.

J. B. PIERCE, Secretary. L. F. MIDDLEBROOK, Asst. Sec'y.

C. S. BLAKE, Supervising General Agent.

E. J. MURPHY, M. E., Consulting Engineer.

F. M. FITCH, Auditor.

BOARD OF DIRECTORS.

FRANK W. CHENEY, Treas. Cheney Brothers Silk Manufacturing Co.
 CHARLES M. BEACH, of Beach & Co.
 GEORGE BURNHAM, Baldwin Locomotive Wks., Philadelphia.
 C. C. KIMBALL, President Smyth Manufacturing Co., Hartford, Conn.
 PHILIP CORBIN, P. & F. Corbin, New Britain, Ct.
 GEORGE A. FAIRFIELD, Ex-Prest. Hartford Machine Screw Co.
 J. B. PIERCE, Secretary Hartford Steam Boiler Inspection and Insurance Co.
 ATWOOD COLLINS, Prest. Security Co., Hartford, Conn.

LUCIUS F. ROBINSON, Attorney, Hartford, Conn.
 JOHN O. ENDERS, U. S. Bank, Hartford, Conn.
 LYMAN B. BRAINERD, President and Treasurer, Hartford Steam Boiler Inspection and Insurance Co.
 MORGAN B. BRAINARD, Asst. Treasurer, Etna Life Insurance Co.
 F. B. ALLEN, Vice-Prest. Hartford Steam Boiler Inspection and Insurance Co.
 CHARLES P. COOLEY, Treas. The Fidelity Company, Hartford, Conn.

Incorporated
1866.

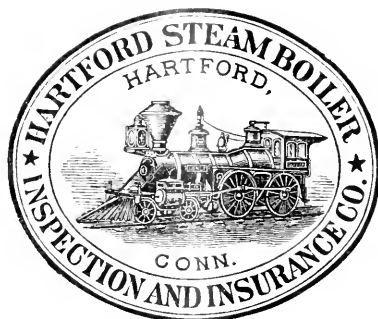

Charter Per-
petual.

The Hartford Steam Boiler Inspection and Insurance Company

ISSUES POLICIES OF INSURANCE COVERING

ALL LOSS OF PROPERTY

AS WELL AS DAMAGE RESULTING FROM

LOSS OF LIFE AND PERSONAL INJURIES DUE TO STEAM BOILER EXPLOSIONS.

*Full information concerning the Company's Operations can be obtained at
any of its Agencies.*

Department.	Representatives.	Offices.
NEW YORK, . . .	C. C. GARDINER, JR., Manager, R. K. McMURRAY, Chief Inspector,	New York City, N. Y., 100 William St.
NORTHEASTERN, . . .	C. E. ROBERTS, Manager, F. S. ALLEN, Chief Inspector,	Boston, Mass., 101 Milk St. Providence, R. I., 29 Weybosset St.
PENNSYLVANIA, . . .	CORBIN & GOODRICH, Gen. Agents, WM. J. FARRAN, Chief Inspector,	Philadelphia, Pa., 432 Walnut St.
MARYLAND, . . .	LAWFORD & MCKIM, Gen. Agents, R. E. MUNRO, Chief Inspector,	Baltimore, Md., 13-14-15 Abell Bldg. Washington, D. C., 511 Eleventh St., N. W.
SOUTHEASTERN, . . .	W. S. HASTIE & SON, Gen. Agts., W. M. FRANCIS, Chief Inspector,	Charleston, S. C., 44 Broad St.
SOUTHERN, . . .	LOUIS V. CLARK & Co., Gen. Agents, H. E. STRINGFELLOW, Chief Inspector,	Birmingham, Ala., 214-216 N. 20th St.
GULF, . . .	PETER F. PESCU, General Agent, R. T. BURWELL, Chief Inspector,	New Orleans, La., 818 Gravier St.
HOME, . . .	E. H. WARNER, General Agent, H. C. LONG, Special Agent, F. H. WILLIAMS, JR., Special Agent, F. S. ALLEN, Chief Inspector,	Hartford, Conn., 650 Main St.
SOUTHERN CONN.,	W. G. LINEBURGH & SON, Gen. Agts.,	Bridgeport, Conn., 1 Sanford Building.
PITTSBURG, . . .	JAMES W. ARROTT, LTD., Gen. Agt., BENJAMIN FORD, Chief Inspector,	Pittsburg, Pa., 401 Wood Street.
NORTHERN OHIO,	C. A. BURWELL, General Agent, H. A. BAUMHART, Chief Inspector,	Cleveland, Ohio, 337 Superior Ave., N. W.
NORTHWESTERN,	H. M. LEMON, Manager, JAMES L. FOORD, Chief Inspector,	Chicago, Ill., 169 Jackson St.
SOUTHWESTERN,	VICTOR HUGO, Manager, VICTOR HUGO, Chief Inspector,	St. Louis, Mo., 319 North Fourth St.
WESTERN, . . .	THOS. F. DALY, General Agent, T. E. SHEARS, Chief Inspector,	Denver, Col., 210-215 Ta- bor Opera House Bldg.
PACIFIC COAST, . . .	H. R. MANN & Co., General Agents, J. B. WARNER, Chief Inspector,	Oakland, Cal., 464 Tenth St.

The Locomotive

PUBLISHED BY THE HARTFORD STEAM BOILER INSPECTION AND INSURANCE COMPANY.

VOL. XXVI.

HARTFORD, CONN., APRIL, 1907.

No. 6.

Concerning Nipples in Sectional Boilers.

We have repeatedly called attention to the exceeding importance of properly rolling and flaring the short tubes, or nipples, that occur in certain forms of sectional boilers; and on several occasions we have printed articles bearing upon this matter, in THE LOCOMOTIVE. We are quite willing to admit that such tubes now receive better attention than was accorded to them some few years ago, and yet we find that there is still room for decided improvement, as we are continually meeting with sectional boilers in which the nipples are not adequately set and flared.



FIG. 1.—ILLUSTRATING THE FAILURE OF NIPPLES.

Tube ends should always receive careful treatment, wherever they occur; but nipples should receive especial attention, because they are often subjected to very severe stress. The parts of the boiler that they unite are subject to slight relative motions, due to the expansion and contraction of the boiler under service conditions. In the case of longer tubes, slight motions of this sort may occur without producing undue stresses, as the natural elasticity, or spring, of the longer tubes will afford sufficient compensation. In short nipples, this elasticity

is absent, or nearly so, and any slight relative motion of the parts to which the ends of the nipple are secured must throw stresses upon the ends of the nipples, for which adequate provision must be made, if serious results are to be avoided. The effects of the vibration which occurs in all steam generators are also concentrated at these points, so that there is a tendency to loosen the hold of the nipples upon the headers, or boxes, or drums, with which they connect. The loosening action of the vibration is important, because the holding power of the nipples is purely frictional when they are merely rolled in, without being flared, and there is liability of the joint becoming weakened so that the holding power will be materially reduced. Slight leakage, or "weeping," is not uncommon at these points, and when it occurs, rapid deterioration from corrosion is likely to ensue; and this will certainly reduce the holding power of the nipples very quickly.

In some types of sectional boilers, the nipples have to support a considerable dead weight, in addition to the load which is laid upon them by the pressure that is carried, and by the stresses that are due to the small relative motions, already referred to, of the parts into which the nipples are secured; and as the tendency nowadays, especially with sectional boilers, is continually towards higher pressures, it is very important that the precaution of setting the tubes in such a manner as to obtain the greatest holding power, or largest factor of safety, should not be neglected.

In order to emphasize the importance of the considerations that are here advanced, we give, in Fig. 1, a photo-engraving which illustrates a recent accident, in which a mud drum was blown off from a sectional boiler through the drawing out of fourteen nipples, by which the drum had been attached to the headers of the boiler. The story of this explosion is as follows: The mud-drum of this boiler had given out, and the boiler was shut down for the attachment of a new drum, and for making a few other slight repairs that had become necessary from the gradual deterioration that is inseparable from service. In the attachment of the new drum it became necessary, of course, to set the fourteen nipples shown in the engraving. This should have been done by the builders of the boiler, or by some one thoroughly well versed in the requirements of the boiler, and provided with the special tools which are almost indispensable to the proper performance of such work; but it was performed by the master mechanic of the firm owning the boiler. We do not wish to question the skill or ability of this man, because, for all we know to the contrary, he may be the best mechanic in the country, so far as general work is concerned. It is obvious, however, either that he was not informed as to the necessity of flaring such nipples, or that he did not have the proper special tools with which to perform the flaring in a proper manner; for as a matter of fact, they were merely rolled into place, and were not flared at all. It is even possible (although we do not assert this as a fact) that, owing to the natural difficulties of doing the work in the cramped space that is available, and to the presumed absence of tools designed especially for the work, the rolling was not done as thoroughly as it would have been in the case of the tubes of a horizontal tubular boiler, which are more accessible.

The new mud-drum was put in position, as described, and the boiler was fired up as usual, and run at a pressure not exceeding 110 lbs. per square inch, the safety-valves being set to blow at that pressure. Three or four weeks after

the repairs had been completed, the boiler was visited by an inspector of the Hartford Steam Boiler Inspection and Insurance Company, and subjected to an external inspection while under steam. At the time of this inspection the pressure observed was 105 lbs., and the safety-valves were found to blow off properly at 110 lbs. No leakage was observed at that time, and the boiler showed no signs of distress, in any way, so far as could be observed. About two weeks later, the nipples pulled out of the mud-drum, as shown in the illustration. It fortunately happened that no person was injured when the drum gave way, and the damage to property was also small, being confined mostly to the boiler itself, and to its setting, although one adjacent boiler, and the boiler room also, were slightly damaged. The total loss was about \$400. We need hardly say that the results might easily have been more serious, and our files contain numerous cases of accidents of this general nature, accompanied by serious loss of life. We have selected this particular case for illustration, because, while it was unaccompanied by serious loss, it affords a perfectly plain example of the danger from imperfect or improper securing of the nipples, uncomplicated by any other circumstance.

In sectional boilers of the type shown in Fig. 1, the weight of the boiler and its accessories is supposed to be supported from overhead beams, and the mud-drum is supposed to hang free from the floor of the setting, so that the boiler can expand and contract, without throwing stresses upon the nipples by which the drum is united to the headers. It sometimes happens, however, that owing to the settling of the supports, or to some other equivalent cause, the drum comes to rest upon the floor of the combustion chamber, so that a sensible part of the weight of the boiler is thrown upon it. When this is the case, it is evident that any slight motion of the boiler, due to expansion or contraction, or to any other cause, will give rise to a considerable stress upon the nipples, and upon the headers and the drum in the vicinity of the nipples. A case came to our attention, recently, in which the bosses on the mud-drum were fractured, from this cause, along the entire length of the drum; the drum giving way and causing the death of one man, as well as a property loss of some two thousand dollars. To avoid accidents from this cause, inspectors should always see that the drum of a boiler of the type shown in Fig. 1 is free from the floor of the setting, so that the boiler can expand and contract freely, without the production of stresses in the drum, the nipples, or the headers.

It seems hardly necessary to say that the same attention should be paid to the flaring of nipples, wherever they are located,—whether in connection with mud-drums, or elsewhere. In some types of sectional boilers, for example, nipples occur in positions similar to that suggested, diagrammatically, in Fig. 2; and care should be taken to have these flared properly, so that they may have a holding power sufficient to ensure their ability to carry any load that may come upon them, with a proper factor of safety.

The importance of flaring the ends of the tubes in a sectional boiler that is to carry a heavy pressure was illustrated, in the issue of *THE LOCOMOTIVE* for May, 1902, by a numerical example, which is republished below. The question of the stress that tends to pull a tube out of its header in a water-tube boiler was discussed in a thorough and elementary manner in *THE LOCOMOTIVE* for December, 1900. In the present place it will only be necessary to say, therefore, that the force that tends to pull the tube out of the header is equal

to the total pressure of the steam against a circle whose diameter is equal to the outside diameter of the tube. Suppose, for example, that the tube is four inches in external diameter, and that the pressure to be carried is 200 lbs. per square inch. To find the force tending to pull the tube out of its header, we have merely to calculate the total pressure that the steam would exert upon a four-inch circle. The area of a four-inch circle is 12.57 sq. in.; and the pressure upon each square inch being 200 lbs., the total pressure against the four-inch circle would be $12.57 \times 200 = 2,514$ lbs. That is, the force tending to pull out a four-inch tube, in a water-tube boiler running at 200 lbs. per sq. in., is 2,514 lbs.

Let us now compare this result with the known holding power of tubes that are expanded, and with those that are flared. In the issues of THE LOCOMOTIVE for May, June, and July, 1881, we printed articles on the holding power of tubes set in various ways; and we give certain of the tabulated results again in this place, in order to emphasize the fact that the holding power is greatly increased when the projecting end of the tube is belled or flared. The tubes upon which these experiments were made were three inches in diameter, externally, in the body.

PRESIDENT J. M. ALLEN'S TESTS OF THE HOLDING POWER OF TUBES.

Number used to Designate Test.	Stress at Which Tube Yielded.	REMARKS.
1075	6,500 lbs.	} Tubes Expanded, but neither flared nor beaded.
1076	5,000 "	
1077	7,500 "	
1078	20,500 "	} Tubes expanded, and ends flared.
1079	19,000 "	

It will be seen that the holding power of the tubes averaged about 6,300 pounds for those that were merely expanded, and about 19,700 pounds for those that were expanded and flared. Flaring therefore multiplied the holding power by about three. If we assume that the holding powers of 3-inch and 4-inch tubes are not greatly different, the increased thickness of the header (over that of the tube-sheet that was used in the experiments here quoted) being perhaps compensated for, roughly, by the larger diameter of the tube, then it is easily seen that a 4-inch tube, merely expanded into place in a water-tube boiler carrying a steam pressure of 200 lbs. per square inch, has a factor of safety of $6,300 \div 2,514 = 2.5$, which is entirely too small. With the tube properly flared, the corresponding factor of safety, under similar conditions, would be $19,700 \div 2,514 = 7.8$, which is quite large enough.

It will be observed that this example applies to a four-inch tube, under a pressure of 200 lbs. per sq. in., and that it takes account only of the stress that is due directly to the pressure of the steam. Now, a nipple has to withstand the same stress as a tube of equal diameter, so far as concerns the direct tendency of the steam pressure to separate the parts to which the nipple is attached; and *in addition* to this, the nipple (as we have pointed out, above) is subject to further stresses of unknown magnitude, due to the slight relative

motions of the parts of the boiler under service conditions. It is plain, therefore, that the nipple should be carefully belled or flared, even when the working pressure is far below the value assumed in the example given above.

In order that it may be properly flared, a nipple (or tube) should project from the header from one-quarter to three-eighths of an inch. If the projection is much less than one-quarter of an inch, the nipple cannot be properly flared; and if it is much greater than three-eighths of an inch, it is difficult to flare the end properly, without causing it to split. A tube that splits when being flared under reasonable conditions, however, is made of material that should not be used for boiler tubes. It is not uncommon to find tubes or nipples projecting through the tube-holes by from $\frac{3}{8}$ in. to 1 inch; but a free end of this length possesses so much spring that correct flaring is almost out of the question, even when no splitting occurs. This is especially true when the tube or nipple is made of steel.

A tube or nipple should always be flared so that its maximum outside diameter, at the extreme end of the flare, shall be at least one-eighth of an inch greater than the diameter of the hole into which the tube or nipple is secured; and we strongly prefer a somewhat greater flare than this. In fact, our general recommendations are, that nipples should project through the header, drum, or tube-sheet by about three-eighths of an inch, and that their ends should be flared so as to have an external diameter at least three-sixteenths of an inch greater than the diameter of the holes.

In setting a tube or nipple that is to be flared, it is not uncommon to expand the tube fully, first, and then flare the end as a subsequent and final operation. According to our experience, this is an incorrect way of doing the work, and it often leads to fractures which could easily have been avoided by a somewhat different mode of procedure. The tube or nipple is necessarily somewhat smaller than the hole into which it is to be secured, the difference in diameter being perhaps a sixteenth of an inch. In setting such a tube or nipple, it should first be passed into the hole and brought to its correct position, and the end should

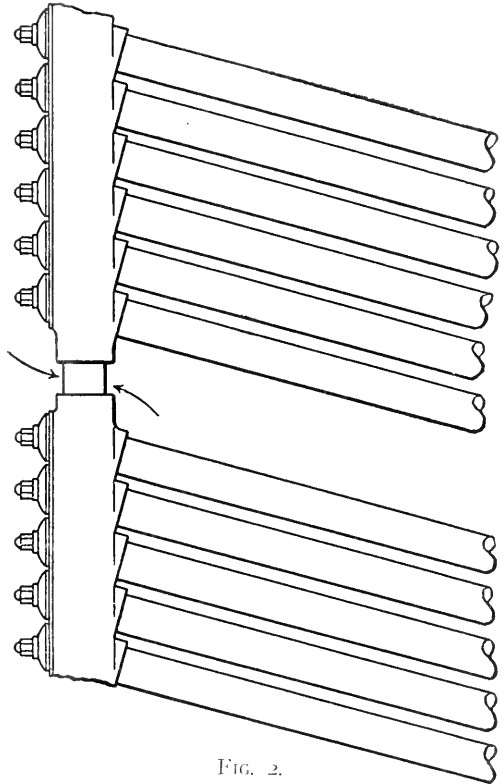

FIG. 2.
SHORT NIPPLE JOINING TWO HEADERS.

then be expanded until the tube is just neatly "tacked," or brought up against the tube-sheet or header with sufficient force to retain it in place. It should then be flared at the free end until it has been swelled out to the proper diameter, and after this has been done, the operation of expanding the tube strongly into the hole should be completed. If the tube is fully expanded into the tube-sheet before being flared, the expanding tool (unless it is of special form) is apt to score the end of the tube so as to make it difficult to perform the flaring, without injury to the tube. The same general remarks apply to beading; for if the tube is completely expanded before being beaded, the ductility of the end is apt to be impaired so that the beading tool will fracture the bead. It is much better and safer to expand the tube until it just fits the hole snugly, and then bead the end over; the expanding being completed after the bead has been formed.

The durability of nipples in sectional boilers depends very much on the care that they receive. The engineer in charge should see that they are kept clean, and are not allowed to corrode. When they are inserted in thick metal with a counter-bored hole, the narrow space of the counter-bore should be kept free from soot and ashes. This involves some trouble, it is true, but it ought to be attended to, and it is altogether too much neglected, in the general run of boilers of this type. The nipples are often found coated with a hard crust, which is formed by the union of soot and ashes with moisture oozing from slight leaks, or with dampness from other sources. Underneath this crust, corrosion and consequent destruction of the nipple goes on rapidly. As a check to such corrosive action, a paint composed of red lead and boiled oil may be used with advantage. The nipple and the counter-bore should both be carefully cleaned before applying it, and the paint should then be thoroughly worked into the counter-bore, so as to cover the nipple completely, at all points.

Inspectors' Reports.

On page 167 we present a general summary, by defects, of the work done by the inspectors of the Hartford Steam Boiler Inspection and Insurance Company, during the months of January, February, and March, 1907. We also give, below, a summary for these months, showing the number of visits of inspection made, the total number of boilers examined, the total number inspected internally, the number tested by hydrostatic pressure, and the number of boilers condemned.

ITEMS.	MONTH (1907).		
	JANUARY.	FEBRUARY.	MARCH.
Number of visits of inspection,	13,577	13,354	14,887
Total number of boilers examined,	27,824	26,006	27,408
Number inspected internally,	8,928	7,703	9,284
Number of hydrostatic tests,	863	881	1,218
Number of boilers condemned,	36	51	67

Inspectors' Reports for January, February, and March, 1907.

NATURE OF DEFECTS.	JANUARY.		FEBRUARY.		MARCH.	
	Total defects.	Dangerous.	Total defects.	Dangerous.	Total defects.	Dangerous.
Cases of deposit of sediment,	1,377	84	1,262	87	1,463	98
Cases of incrustation and scale,	3,950	83	2,679	87	2,846	103
Cases of internal grooving,	177	20	292	21	244	30
Cases of internal corrosion,	906	38	809	35	951	44
Cases of external corrosion,	658	49	638	50	786	37
Defective braces and stays,	168	68	161	68	142	32
Settings defective,	516	74	373	42	500	52
Furnaces out of shape,	651	46	463	20	564	30
Fractured plates,	316	50	226	37	347	69
Burned plates,	402	44	432	40	362	40
Laminated plates,	67	6	48	7	61	13
Cases of defective riveting,	341	149	282	56	291	118
Defective heads,	129	46	95	7	124	20
Leakage around tubes,	932	100	827	65	906	114
Cases of defective tubes,	652	287	759	468	551	247
Tubes too light,	251	43	170	52	241	111
Leakage at joints,	635	35	362	29	498	36
Water-gages defective,	266	55	211	48	260	78
Blow-offs defective,	315	88	256	67	312	98
Cases of deficiency of water,	44	19	42	17	32	15
Safety-valves overloaded,	115	25	94	41	73	24
Safety-valves defective,	90	31	97	38	89	34
Pressure gages defective,	566	32	581	40	618	23
Without pressure gages,	8	8	7	7	9	9
Unclassified defects,	15	0	0	0	1	0
Totals,	12,707	1,486	11,166	1,429	12,271	1,475

Boiler Explosions.

JANUARY, 1907.

(1.) — A boiler exploded, January 1, on Capt. Thomas Dixon's steamer *Uncle Sam*, at Newbern, N. C. Fireman Hardy Bennett was killed.

(2.) — On January 4 a boiler exploded in Alumni Gymnasium, at the University of Rochester, Rochester, N. Y.

(3.) — Several cast-iron headers fractured, January 4, in a water-tube boiler at the Excelsior Needle Co.'s plant, Torrington, Conn.

(4.) — A boiler exploded, January 5, in Henderson's greenhouse, Millville, N. J.

(5.) — A boiler exploded, January 5, in the Sunnybrook Distillery, Louisville, Ky. Property loss, \$10,000.

(6.) — On January 7 a safety boiler exploded in the power-house of the West Chester Traction Co., at Llanerch, Pa. The roof of the building was badly wrecked.

(7.) — On January 7 a tube ruptured in a water-tube boiler at the plant of the Evansville Cotton Mfg. Co., Evansville, Ind.

(8.) — A blowoff pipe failed, January 7, in the Chicago Coated Board Co.'s plant, Chicago, Ill. E. L. Holly, a water-tender, was killed.

(9.) — A slight explosion occurred, January 7, in the Electric Light & Water Works plant of the City of Wayne, Wayne, Neb.

(10.) — A boiler exploded, January 7, in T. D. Wainwright's sawmill, at Atlanta, La. T. D. Wainwright, John Gafford and Monroe Plunkett were killed, and B. Gresham was injured. The mill was wrecked.

(11.) — A water-tube boiler exploded, January 11, in the plant of the Wadsworth Salt Co., Wadsworth, Ohio.

(12.) — On January 11, a number of cast-iron headers fractured in a water-tube boiler at the plant of the Robeson Iron Co., Robeson, Pa.

(13.) — A boiler flue burst, January 14, in the roundhouse at Moorhead, Minn. John Holst, a machinist, was badly scalded, and he died a few hours later.

(14.) — A boiler exploded, January 15, on E. Schaefer's plantation, three miles west of Yazoo City, Miss. Henry Redding, Thomas Carter, and Carter Estey were killed.

(15.) — A slight explosion occurred, January 15, at Innod & Co's flouring mill, Athens, Ohio.

(16.) — The boiler of the Philadelphia & Reading railroad's freight locomotive No. 879 exploded, January 15, at Bridgeport, opposite Norristown, Pa. Charles M. Stein, Ray Schrader, Elmer J. Cain, Adolph Krause and John Knobloch were killed, and Jacob D. Blank was injured.

(17.) — A blowoff pipe failed, January 15, in the plant of the W. L. Gilbert Clock Co., at Winsted, Conn. Engineer Fitzgerald was badly injured, and he died a few hours later.

(18.) — A slight accident occurred, January 18, to a boiler in the Children's Hospital, Boston, Mass.

(19.) — A boiler ruptured, January 18, in the Franklin Brewing Co.'s plant, Columbus, Ohio.

(20.) — A tube ruptured, January 18, in a water-tube boiler at the Allston

station of the Boston Consolidated Gas Co., Brighton, Mass. Fireman Edmund W. Taylor was injured.

(21.) — The boiler of a freight locomotive exploded, January 19, on the Atchinson, Topeka & Santa Fe railroad, at Kill Creek, near De Soto, Kans. Engineer F. W. Bartell and brakeman H. E. Shaw were killed.

(22.) — On January 19 a blowoff pipe failed in the Rector Milling Co.'s roller mill, Rector, Ark. Property loss about \$850.

(23.) — On January 19 a tube ruptured in a water-tube boiler in the Sioux City Traction Co.'s power plant, Sioux City, Iowa. J. P. Haller and Carl Haller were injured.

(24.) — On January 20, the boiler of a fast passenger locomotive exploded, on the Reading railway system, at Blue Anchor, near Camden, N. J., while drawing an express train from Atlantic City to Camden. Engineer Edward McConaghy and firemen J. Wilbert Arthur and James Clark were killed.

(25.) — A slight explosion occurred, January 20, in the Pepperell Manufacturing Co.'s plant, Biddeford, Me.

(26.) — A boiler exploded, January 21, in C. P. Kroll's cigar box factory, Traverse City, Mich. Mr. Kroll was killed.

(27.) — On January 21 several cast-iron headers fractured in a water-tube boiler at the Crown Cork & Seal Co.'s plant, Baltimore, Md.

(28.) — A boiler exploded, January 24, in the Terre Haute Steam Heating Plant, Terre Haute, Ind. Lucius Rainey and C. T. Miller were scalded to death.

(29.) — The boiler of a portable sawmill exploded, January 25, at Steep Falls, Me. Elmer Sanborn was killed.

(30.) — A large hot-water boiler exploded, January 26, at the Intervale Club, Lynn, Mass. The property loss was about \$2,000.

(31.) — A boiler exploded, January 27, in an oil pumping house, near Chicora, Pa. Judd Steele was killed, and Richard Campbell was fatally injured.

(32.) — A number of cast-iron headers fractured, January 27, in a water-tube boiler at the American Beet Sugar Co.'s plant, Grand Island, Neb. J. J. Walker was severely scalded.

(33.) — A hot-water boiler exploded, January 27, in the laundry of Dummer Academy, South Byfield, Mass. Miss Clara A. Dawson and Miss Martha Anderson were seriously injured.

(34.) — A small steam boiler, attached to a sewing machine in a shoe shop in the Arcade, East St. Louis, Ill., exploded, January 29, causing a property loss of about \$400.

(35.) — A boiler fractured, January 29, in the Bridgeport Crucible Co.'s plant, Bridgeport, Conn.

(36.) — On January 29 a boiler ruptured in the Starr Piano Co.'s factory, Richmond, Ind.

(37.) — The boiler of locomotive No. 7957, on the Pennsylvania railroad, exploded, January 30, four miles east of Columbia City, Ind. Engineer William C. Bender and fireman Ervin F. Lowe were killed, and brakeman G. V. Bogan was injured. The locomotive was destroyed.

(38.) — A boiler ruptured, January 30, in Mayo & Sons' plant, Foxcroft, Me.

(39.) — On January 31 two sections of a cast-iron sectional heating boiler ruptured at the school of the Sisters of the Faithful Companions of Jesus, Fitchburg, Mass.

(40.) — A boiler exploded, January 31, in Patman's mill, five miles east of Hughes Springs, Tex. William Hall was killed.

(41.) — A small boiler exploded, January 31, on the Steger farm, Dyersville, Iowa, wrecking the building in which it stood.

(42.) — On January 31 a boiler exploded at the Maud S. Steam Pump Co.'s works, Lansing, Mich. Engineer Louis Gilbert was fatally injured.

FEBRUARY, 1907.

(43.) — The boiler of a steam shovel exploded, February 1, at Thomasville, N. C. L. G. Lea was killed.

(44.) — On February 1 a tube ruptured in a water-tube boiler at the power plant of the Potomac Electric Power Co., Fourteenth and B streets, Washington, D. C. Thomas Denneil and Walter Morgan were injured.

(45.) — A boiler used in drilling for oil exploded, February 2, near Cory, Ind.

(46.) — A slight boiler explosion is said to have occurred, February 2, at the plant of the Pacific Coast Biscuit Co., Portland, Ore. B. W. Morrison was severely burned.

(47.) — On February 3 a header broke in a water-tube boiler in Austin B. Fletcher's apartment house, 312-320 Manhattan Ave., New York City.

(48.) — A blowoff pipe failed, February 3, at the Agricultural Station of the State of Minnesota, St. Anthony Park, Minn. Fireman John Lundegren was injured.

(49.) — A boiler belonging to James Hamilton, of Malta, Ill., ruptured on February 3.

(50.) — The crown sheet of locomotive No. 1156, of the Boston & Maine railroad, gave way, February 4, at Johnsonville, N. Y. Three men were seriously injured, and the locomotive was wrecked.

(51.) — A tube (or a blowoff pipe) failed, February 4, in the plant of the International Automobile & Vehicle Tire Co., at Millerton, N. J. Fireman James Hoover was seriously burned.

(52.) — On February 5 a boiler exploded on the New York, New Haven & Hartford railroad company's wrecking derrick No. 30, at New London, Conn.

(53.) — The boiler of a freight locomotive exploded, February 5, on the Chesapeake & Ohio Railroad, near Colby Station, ten miles from Lexington, Ky. Three men were killed, and several others were injured.

(54.) — A tube burst, February 5, in a boiler at the Edgar Thomson Steel Works, Braddock, Pa. Samuel Clemenson and John Sherman were injured.

(55.) — A boiler exploded, February 5, on the sandboat *Parker*, at Williams Island, on the Tennessee river, nine miles from Chattanooga, Tenn. George Kelley was killed, William D. Sibley and Robert Bass were blown into the river and presumably drowned, and Capt. James Thompson and engineer Jesse Allison and his wife were severely injured.

(56.) — A tube ruptured, February 7, in a water-tube boiler at the plant of the Home Lighting, Power & Heating Co., Springfield, Ohio.

(57.) — Three men were instantly killed, February 7, by the explosion of a traction engine boiler at Selby, four miles north of Napanee, Ont.

(58.) — A water-tube boiler ruptured, February 7, in the Skandia Furniture Co.'s plant, Rockford, Ill.

(59.) — Several cast-iron headers ruptured, February 8, in a water-tube boiler at the Sweeney Company's department store, Buffalo, N. Y.

(60.) — A boiler exploded, February 9, at the Eclipse mine, Boone, Iowa. P. A. Turnell was killed.

(61.) — The boiler of locomotive No. 2599, belonging to the New York Central railroad, exploded, February 10, at Chester, Mass., on the Boston & Albany railroad. Engineer Joseph Murphy was fatally injured, and died some three weeks after the accident. Fireman Walter Robarge and brakeman Percy Hutchinson were also injured seriously.

(62.) — On February 11 a boiler exploded in a cotton mill at Pell City, Ala. Alexander Jones was killed, another man was injured, and the mill and machinery were badly damaged.

(63.) — A boiler exploded, February 11, in Porter's ice and electric plant, Live Oak, Fla. The roofs of the boiler house and engine room were wrecked.

(64.) — A section fractured, February 11, in a cast-iron sectional hot-water boiler, at the Church of St. Cyril and St. Methodius, Hartford, Conn.

(65.) — On February 11 a cast-iron sectional boiler fractured at the New Orleans Polyclinic Sanitarium, New Orleans, La.

(66.) — Several headers ruptured, February 11, in a water-tube boiler at the Brazos Hotel, Houston, Tex.

(67.) — A tube ruptured, February 11, in a water-tube boiler at the power plant of the Illinois Traction Co., Decatur, Ill. Charles Strevers was injured.

(68.) — A blowoff pipe ruptured, February 12, in J. Capps & Sons' woolen mill, Jacksonville, Ill. Engineer Hermann Arpe was injured.

(69.) — On February 13 a tube ruptured in a water-tube boiler at the Central power house of the Brooklyn Heights R. R. Co., Brooklyn, N. Y. Fireman Charles Gallagher was scalded.

(70.) — A boiler exploded, February 13, in R. R. Robinson's feather cleaning plant, Galt, Ont. Engineer Robert A. Johnson was fearfully scalded.

(71.) — A boiler used to operate a donkey engine exploded, February 13, on the Hamburg-American steamship *Valdiva*, off Cape Hatteras, N. C. Seven men were killed, three were injured, and the property loss was considerable.

(72.) — The boiler of an Ontario & Western passenger locomotive exploded, February 13, at Luzon, Sullivan county, N. Y., thirty-three miles north of Middletown. Fireman Martin Mullen was instantly killed, and engineer William Gadwood was fatally injured.

(73.) — On February 14 a blowoff pipe failed at the Hotel Euclid, Cleveland, Ohio. Engineer John Comyans was scalded.

(74.) — A tube ruptured, February 17, in a water-tube boiler at the Indiana Union Traction Co.'s plant, Anderson, Ind.

(75.) — On February 17, seven sections of a cast-iron sectional boiler fractured in the New York Central railroad station at Corning, N. Y.

(76.) — A locomotive boiler, used for the storage of compressed air, exploded, February 18, in the shops of the Louisville & Nashville railroad, Mobile, Ala. George Martin was injured.

(77.) — A boiler exploded, February 18, in L. M. Brouters' sawmill, at State Line, Ark. Wallace Brown and James Seabaugh were killed, C. M. Letts and John Person were fatally injured, and twenty-three others received lesser injuries.

(78.) — The boiler of freight locomotive No. 184, of the Southern Pacific railroad, exploded, February 19, at Strange, near Houston, Tex. Engineer George Merchant was instantly killed, and fireman B. Elliott was seriously injured.

(79.) — A tube ruptured, February 19, in a water-tube boiler at the B. F. Goodrich Co.'s rubber works, Akron, Ohio.

(80.) — The mud drum of a water-tube boiler exploded, February 19, in the rod mill of the American Steel & Wire Co., at Newburg, Ohio. One man was instantly killed, one was fatally injured, and a third received lesser injuries.

(81.) — A tube ruptured, February 21, in a water-tube boiler at the Western Gas & Investment Co.'s plant, Seymour, Ind. Fireman Harry Winscott was injured.

(82.) — A boiler exploded, February 21, in T. E. Wardell's feed mill, near Macon, Mo. Frederick Harris was killed.

(83.) — On February 23 a boiler exploded in Frederick Towle's laundry, Gardiner, Me. The building and its contents were demolished.

(84.) — A section fractured, February 23, in a cast-iron sectional boiler in the office building, Nos. 2 and 4 Park Square, Boston, Mass.

(85.) — A tube burst, February 24, in a boiler in the basement of the Planters' Hotel, St. Louis, Mo. Fireman James Cummings was badly scalded.

(86.) — On or about February 25, a heating boiler exploded in Langston College, Langston, Okla.

(87.) — The boiler of freight locomotive No. 816, on the El Paso division of the Galveston, Harrisburg & San Antonio railroad, exploded, February 25, at Chocar, an isolated station twenty-four miles east of Sierra Blanca, Tex. The engineer and fireman were seriously injured, and the locomotive was badly damaged.

(88.) — A boiler exploded, February 26, at the plant of the Record Publishing & Carton Co., Battle Creek, Mich. Mrs. Frederick Madison was seriously injured. The boiler room was wrecked, and the factory itself was badly damaged.

(89.) — Ten sections fractured, February 27, in a cast-iron sectional boiler in the Evening News Publishing Co.'s building, Baltimore, Md. Engineer Harry L. McGee was injured.

(90.) — A boiler exploded, February 28, in the power plant of the Citizens' Railway, Light & Power Co., Fort Worth, Tex.

(91.) — The boiler of a Rock Island locomotive exploded on or about February 28, at Earlsborough, Okla. Engineer William F. Smith and the head brakeman (whose name we have not learned) were killed, and the fireman was injured.

(92.) — The boiler of a Michigan Central locomotive exploded, February 28, in Chicago, Ill. Fireman August Kreff was killed.

MARCH, 1907.

(93.) — A heating boiler exploded, March 4, in the Franklin School, Plainfield, N. J. No pupils were in the building at the time. The janitor, Thomas Clarkson, was badly scalded.

(94.) — Two tubes and two cast-iron headers failed, March 4, in a water-tube boiler at the Horstmeier Lumber Co.'s plant, Baltimore, Md.

(95.) — On March 5 a blowoff pipe failed in the plant of the Western Stoneware Co., Branch No. 6, Clinton, Mo. Fireman Luther Jenkins was severely injured.

(96.) — A tube ruptured, March 6, in a water-tube boiler at the Fremont street plant of the Worcester Consolidated Street Railway Co., Worcester, Mass. Fireman B. Ziski was injured.

(97.) — A boiler exploded, March 7, at an oil well on the Block farm, near Woodfield, Ohio. Edward Douglas and Frank Madison were killed, and Frank Sulsberger was injured. The boiler house was completely destroyed.

(98.) — The boiler of a Pennsylvania railroad freight locomotive exploded, March 7, at Frazer, Pa. Fireman Stoner was killed, and engineer Kelley was badly injured.

(99.) — A slight boiler accident occurred, March 8, in the Hotel Altamont, Baltimore, Md.

(100.) — Several headers fractured, March 10, in a water-tube boiler at Hotel Narragansett, Providence, R. I.

(101.) — The boiler of a Pennsylvania railroad mogul freight locomotive exploded, March 11, at Metuchen, N. J. Engineer J. W. Fisher, fireman W. H. Fritchie, and head brakeman C. A. Smith were killed, and a trackwalker was painfully injured.

(102.) — A boiler exploded, March 12, in Samuel Bain's sawmill, at Lunenburg, Va. Two men were killed, and one was injured.

(103.) — The boiler of a Salt Lake railroad switching locomotive exploded, March 14, at Los Angeles, Cal. J. F. Taylor, Lewis L. Pettit, Marselino Espinosa, Charles C. Hitt, V. Guzman, Basenta Molena, and M. Busman were injured.

(104.) — A blowoff pipe ruptured, March 15, at the spoke factory of Frank & Foltz, Humboldt, Tenn. Fireman Lidge Sheppard was injured.

(105.) — A heating boiler exploded, March 15, in the synagogue of the Heska Amona-Orthodox Hebrew Congregation, Memphis, Tenn. The property loss was about \$500.

(106.) — On March 17 a cast-iron header fractured in a water-tube boiler at the plant of A. H. Belo & Co., Dallas, Tex.

(107.) — The boiler of a locomotive exploded, March 18, in the Cincinnati, Hamilton & Dayton railroad yards, at Cincinnati, Ohio. Engineer George Morgan, fireman Walter Griffiths, and switchman Frank Burton were fatally injured.

(108.) — A boiler exploded, March 18, in Foss, Hatfield & Co.'s candy factory, Richmond street, Boston, Mass. Engineer Stephen Bartlett was seriously injured.

(109.) — A blowoff pipe ruptured, March 18, at the Stineman Coal Mining Co.'s plant, South Fork, Pa. Engineer William Roerabaugh was somewhat scalded.

(110.) — A boiler exploded, March 19, on N. R. Lester's plantation, about five miles from Prosperity, S. C. Mr. Lester and one other man were killed, and a third man was injured.

(111.) — A boiler exploded, March 19, in Mrs. John Bird's sawmill, seven miles east of Kalkaska, Mich., demolishing the mill.

(112.) — Six persons were killed, March 20, by a boiler explosion at the Woodward Iron Furnace, Woodward, Ala.

(113.) — A slight boiler accident occurred, March 20, at the Union Soapstone Co.'s plant, Chester, Vt.

(114.) — A boiler exploded, March 20, at the plant of the Crescent Lumber Co., Shelby, Ky. Edward Thacker was fatally injured, and two other men were injured less seriously.

(115.) — The crown-sheet failed, March 21, on a Santa Fe freight locomotive, at Siam, between Barstow and Needles, Cal. Fireman J. B. Kerr was instantly killed, engineer P. Barnum was fatally injured, and brakeman J. L. McElroy was injured badly, but not fatally.

(116.) — The boiler of a donkey engine, used for hoisting purposes, exploded, March 21, on the ship *St. Frances*, at Tacoma, Wash. Ship's carpenter G. A. Maynus was fatally scalded.

(117.) — A boiler exploded, March 22, at the Brazos Hardwood Lumber Co.'s plant, six miles south of Marlin, Tex. Elijah Jones and Austin Hopper Wood were killed, Walter Poole was fatally injured, and R. G. Poole and Wesley Ramsey were injured seriously but not fatally.

(118.) — A boiler exploded, March 22, at the Nicholson Coal Co.'s plant, Nicholson, Tenn. According to one report, the explosion of the boiler caused the subsequent explosion of a large quantity of powder. The tipple machinery was wrecked, as well as a number of houses in the vicinity. The property loss was estimated at from \$10,000 to \$20,000.

(119.) — A tube ruptured, March 24, in a water-tube boiler at the East Boston Coal Co.'s colliery, Kingston, Pa.

(120.) — The boiler of a Santa Fe freight locomotive exploded, March 25, near Onava, N. M. Three men were killed, and the locomotive was destroyed.

(121.) — The boiler of a freight locomotive exploded on the Boston & Albany railroad, March 26, at State Line, Mass. Engineer John James, fireman Frederick Luce, and head brakeman Hynes were badly scalded.

(122.) — The boiler of a freight locomotive exploded, March 28, on the Pittsburg, Youngstown & Ashtabula railroad, at Lockwood, thirty miles south of Ashtabula, Ohio. Engineer H. E. Watson was killed, and fireman F. F. Bancroft, brakeman John Curry, and a tramp named Howard Sampler were badly injured. The locomotive was destroyed.

(123.) — A boiler ruptured, March 29, at the Buckeye Brewing Co.'s brewery, Toledo, Ohio.

(124.) — On March 29 a blowoff pipe failed in the Hamilton City Ice & Cold Storage Co.'s plant, Hamilton, Ohio. Fireman Charles Conover was severely scalded.

(125.) — A cast-iron header fractured, March 29, in the Thirteenth and Mt. Vernon street power station of the Philadelphia Rapid Transit Co., Philadelphia, Pa.

(126.) — A blowoff pipe ruptured, March 31, at the Woodward Lumber Co.'s plant, Atlanta, Ga.

(127.) — On March 31 a slight accident occurred to a boiler at the Shove Mills, Tiverton, R. I.

The Locomotive.

A. D. RISTEEN, PH.D., EDITOR.

HARTFORD, APRIL, 1907.

THE LOCOMOTIVE can be obtained free by calling at any of the company's agencies
Subscription price 50 cents per year when mailed from this office.
Bound volumes one dollar each. (Any volume can be supplied.)

Obituary.

WALTER LEE CALDWELL.

Mr. Walter Lee Caldwell, a special agent in the New York department of the Hartford Steam Boiler Inspection and Insurance Company, died January 21, at Richmond, Virginia. Mr. Caldwell was born May 20, 1868, at Pulaski, Virginia, and passed his childhood in the neighboring village of Snowville. At the age of 16 he entered the employ of Gibbs & Hancock, tobacco merchants at Lynchburg, as bookkeeper; and from that time he was the support of his widowed mother and invalid sister. Three years later he became a traveling salesman for J. H. Franklin & Son, of Lynchburg, and subsequently he became a grocery broker in the same town. About fifteen years ago he went to Chicago, where he entered the employ of the H. J. Heinz Company, as assistant manager. He was subsequently placed in charge of the Albany branch of the same company, remaining in that position two years. He was later employed by Armour at Boston, and on August 1, 1901, he took the position with this company that he held at the time of his death. In 1893, Mr. Caldwell married Miss Nellie Bell, of Lynchburg, Virginia, who survives him. He also leaves a son, Walter, nine years of age. His mother and sister died a few years ago.

Mr. Caldwell was a Knight Templar, a thirty-second degree Mason, and a member of Mecca Temple, New York city. He was unusually successful in business, and he was noted for his magnificent physique, distinguished bearing, and attractive personality. He was likewise a man of fine character, and of manly, chivalrous instincts; and his untimely death is deeply regretted by a large circle of friends.

THE Hartford Steam Boiler Inspection and Insurance Company has acquired a substantial control of the stock of The Boiler Inspection and Insurance Company of Canada. The Canadian company, which has a perpetual charter with broad powers direct from the Dominion Parliament, was incorporated in 1875, and began business in the same year; and it has since made a specialty of, and done exclusively, a steam boiler inspection and insurance business. It has an authorized capital of \$500,000, a subscribed capital of \$100,000, a paid-up capital of \$75,075, assets of about \$135,000, and insurance in force ex-

ceeding \$6,000,000. It has upon its books, and is now doing, about three-quarters of the entire steam boiler insurance business of the Dominion.

The methods of the Canadian company, and its standards of mechanical service, have been maintained on a high plane of efficiency; and its position, as well as its affiliations with steam users throughout the Dominion, correspond, in a striking manner, to those possessed by the HARTFORD throughout the United States. The executive officers, and in fact the entire staff, have been retained; and it will be the endeavor of the HARTFORD'S management, through its wider and more extended experience and greater financial resources, to further build up and strengthen the position of the company throughout the Dominion, and so enable it to meet, with ever increasing success, the present day demands with respect to efficiency of service and protection required.

At the annual meeting of the stockholders of the Hartford Steam Boiler Inspection and Insurance Company, held on February 12th, Mr. Arthur L. Shipman, corporation counsel of the city of Hartford, was elected a member of the board of directors of the company.

On the same date Mr. Charles S. Blake, who had been supervising general agent of the company for nearly three years, was elected, by the directors, to the position of second vice-president.

The Areas of Circular Segments.

In determining the number of braces that are required in order to afford a proper support to the head of a horizontal tubular boiler, it is necessary, first of all, to calculate the area of the part that requires bracing; and as this area has the form of a segment of a circle, the calculation is not altogether simple. It is easy enough to give an exact formula for computing the area of a circular segment, but the application of this formula calls for some small knowledge of trigonometry, so that it cannot be carried out by persons to whom trigonometry is unfamiliar. Moreover, the exact formula calls for the use of trigonometric tables, and it is therefore unserviceable when such tables are not at hand. For these reasons it is customary, in practical work, to avoid the use of the exact formula by resorting to one or the other of two expedients.

The first of the two expedients here referred to consists in the employment of a table, which has been computed, once for all, from the exact formula, and which gives the area of circular segments of different heights, for a circle having a diameter of one unit,—say, for example, a diameter of one inch or of one foot. Such a table is given in the issue of THE LOCOMOTIVE for October, 1903, where an illustrative numerical example will also be found.

We recommend the use of the table just cited, when it is at hand, because the calculation is easy, and the result is exact, to a number of significant figures corresponding to the number of decimals given in the table. This method has the advantage of dispensing with the employment of an unfamiliar trigonometric formula, but it has, at the same time, the serious disadvantage that it cannot be employed when the table is not accessible. In a case of this kind it is usual to resort to the second of the two expedients to which refer-

ence has been made above; this second expedient consisting in the use of some *approximate* formula, which is simpler than the exact one, and which is known to give results that are close enough to the truth for all practical purposes, although they are admittedly not *exact*.

A number of such approximate formulas have been suggested, and in a previous issue of THE LOCOMOTIVE (January, 1890, page 11) we gave three, which are also republished in the present article, for the sake of convenience of reference and comparison. Following these three we give, below, several other approximate rules, each of which has its advantages and disadvantages. The sixth rule (Mr. Platt's) is the one which is perhaps most useful for rough purposes, since it is simple in form, and also gives results that are accurate enough for the general use of the inspector.

Following is a rule that is simple enough, but which gives results that may be in error by fifteen per cent. or thereabouts. When such an error is permissible, this rule may be used; but when further refinement is necessary, one of those given below should be substituted for it. The shaded portion of Fig. 1 represents the segment whose area is desired; and this shaded section may be regarded as composed of the triangle ABC , together with the two small segments that lie above the lines AB and BC , respectively. The area

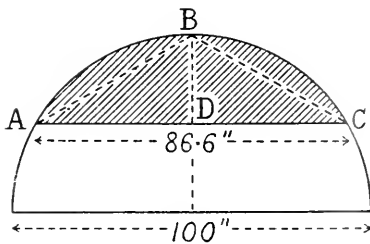

FIG. 1.—ILLUSTRATING RULE 1.

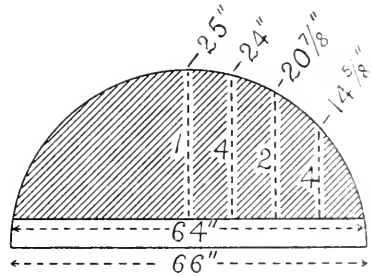

FIG. 2.—ILLUSTRATING RULE 2.

of the triangle ABC is found by multiplying the base, AC , by one-half of the altitude, BD . It may be shown, by calculations made by more exact methods, that the two small segments, resting upon the lines AB and BC , are together equal to something like one-half of the area of the triangle ABC . Therefore we have the following rule for the area of the entire shaded segment:

RULE 1. Multiply the base of the segment, AC , by half of the height, BD , and to the product add one-half of itself. (The error of this rule may amount to 15 per cent. or so.)

In the segment shown in Fig. 1, the rule gives a result that is too large by about 5.8 per cent.

A second method for finding the area of a segment approximately is illustrated in Fig. 2, and is based upon Simpson's rule for irregular figures. (See Rankine's *Rules and Tables*.) It may be described as follows:

RULE 2. Divide the base of the segment into halves, and divide one of these halves into four equal parts. Draw perpendiculars through each point of division until they meet the circle, and measure each one of the perpendiculars. Then multiply the one at the middle of the segment by 1, the next by 4, the next by 2, and the last by 4. Add all the products together, multiply the

sum by the base of the segment, and divide by 12. (The error of this rule, due to the imperfection of the rule itself, and taking no account of error due to imperfection in the measurements, is never greater than one per cent. In the case of the segment shown in Fig. 2, the rule is in error by about two-thirds of one per cent.)

A similar but very much simpler rule may be given, which is never more than four per cent. in error, and which suffices for most of the requirements of the inspector, so far as accuracy is concerned. It is illustrated in Fig. 3.

RULE 3. Divide the base of the segment into halves, and divide one of these halves again into halves. Through each point of division of the base line of the segment draw a vertical line up to the circle. Measure both of these vertical lines, and to the long one add four times the short one. Multiply the sum by the base of the segment, and divide by 6. (The result cannot be in error by more than four per cent., if the measurements are accurately made.)

The three approximate rules given above apply to segments of any height whatever. The unbraced segments on the heads of horizontal tubular boilers vary within comparatively narrow limits, however, and this circumstance makes it possible to give, for the use of the inspector, approximate rules which are simple in form, and which, at the same time, are fairly accurate for segments

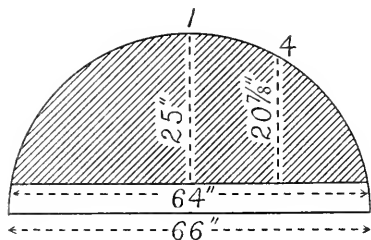

FIG. 3.—ILLUSTRATING RULE 3.

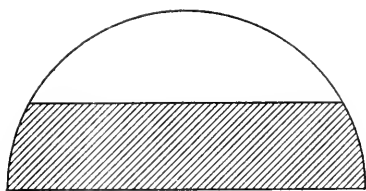

FIG. 4.—SEGMENT SHOWN WHITE, AND REST OF SEMICIRCLE SHADED.

having proportions such as occur on the heads of the ordinary horizontal tubular steam boiler.

Consider, for example, Fig. 4, which represents a complete semi-circle, which has been divided, by a horizontal line, into two parts, one of which is shown shaded, and the other white. The white portion represents the segment whose area is required, and the shaded portion of course represents the remainder of the semi-circle. Now, we may proceed to calculate the area of the white segment in either one of two ways. Namely, we may calculate it *directly*, in the manner illustrated by the rules already given, or we may calculate it *indirectly*, by first determining the area of the part shown shaded, and then subtracting the area of this shaded part from the known area of the entire semi-circle. For segments such as commonly occur in horizontal tubular boilers it happens to be easy to give approximate rules for finding the area of the shaded strip in Fig. 4,—rules which are at the same time simple and fairly accurate, as will appear from what follows.

The most obvious way to obtain an approximate value of the area of the shaded part of Fig. 4 is to treat it as a rectangle, having a length equal to the diameter of the circle. This mode of procedure is illustrated in Fig. 5,

which shows a segment, 20 inches in height, in a circle 66 inches in diameter. The width of the rectangular strip is here 13 in., and its length is 66 in., so that its area is $13 \times 66 = 858$ sq. in. The area of the whole semi-circle may be obtained by means of a table of areas of circles, such as the one printed in the issue of THE LOCOMOTIVE for October, 1903, or it may be calculated directly by multiplying the square of the diameter of the circle by the decimal 0.3927 (which is one-half of 0.7854). In either case we find that the area of the semi-circle is 1710.6 sq. in.; and, taking the area of the rectangle away from this, we have $1710.6 - 858.0 = 852.6$ sq. in., which is the area of the segment in question, as calculated by this approximate method. The true area of this segment is 875.3 sq. in., so that the error due to the approximation here adopted is, in the present case, 22.7 sq. in., or 2.6 per cent. of the total area of the segment. The foregoing process may be formulated, for convenience of reference, as follows:

RULE 4. Subtract the height of the given segment from the radius of the circle, and multiply the result by the diameter of the circle. The product so found is to be subtracted from the area of the semi-circle of which the segment forms a part, and the remainder is the approximate area of the segment. (This rule gives approximate results only when the strip shown shaded in Fig. 4

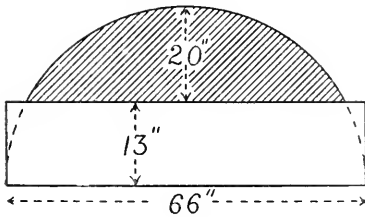

FIG. 5.—ILLUSTRATING RULE 4.

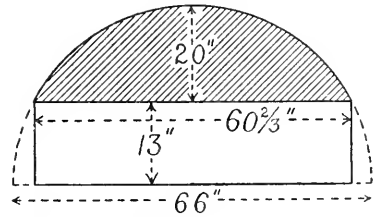

FIG. 6.—A METHOD LESS ACCURATE THAN FIG. 5.

is approximately a rectangle. The error of the rule amounts to five per cent. when the height of the segment is 0.272 times the diameter of the circle. Roughly, we may say that when the *height* of the segment is *greater* than one-quarter of the diameter of the circle, the rule may be trusted to give a result within five per cent. of the truth.)

Instead of taking the shaded area of Fig. 4 as equal to a rectangle having a length equal to the diameter of the circle, we may take it as having a length equal to the base of the segment, as indicated in Fig. 6; but it is easily shown that the rule obtained in this manner is not quite so close as the one just given.

The true area of the shaded portion of Fig. 4 lies somewhere between the rectangles shown in Figs. 5 and 6; one of these rectangles being plainly too short, while the other is too long. Fig. 7 illustrates a method that has been in use for many years, for obtaining a rectangle intermediate in length between these two, and hence presumably more nearly correct than either. It may be described thus:

RULE 5. Subtract the height of the given segment from the radius of the circle, and multiply the result by the length of a chord of the circle (CD in Fig. 7) which lies half-way between the base of the given segment and the center of the circle. The product so found is to be subtracted from the area

of the semi-circle of which the segment forms a part, and the remainder is the approximate area of the segment. (The error of this rule is five per cent. when the height of the segment is 0.197 times the diameter of the circle, assuming the measurements to be correctly made. It always gives results more accurate than Rule 4; and for a segment whose height is 0.272 times the diameter of the circle, its error is only about $1\frac{1}{4}$ per cent., as against an error of 5 per cent. for Rule 4, as above stated.)

Mr. C. E. Platt, an inspector in the Southeastern Department of the Hartford Steam Boiler Inspection and Insurance Company, suggested, some time ago, that a sufficient degree of approximation for most practical purposes is obtained by assuming, in the case of the segments that actually occur on the heads of horizontal tubular boilers, that the shaded strip of Fig. 4 is equal to the area of a rectangle having a width equal to that of the strip itself, and a length that is in every case one inch shorter than the diameter of the circle. Embodying this suggestion in the form of a rule, we have:

RULE 6. Subtract the height of the given segment from the radius of the circle, and multiply the result by the diameter of the circle, diminished by one inch. Subtract the product so found from the area of the semi-circle of which the segment forms a part, and the result is the approximate area of the segment. All measurements are to be made in inches. The degree of approxima-

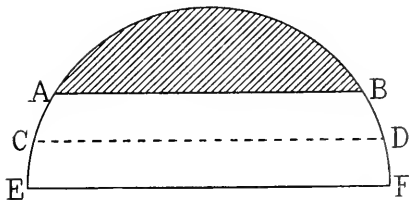

FIG. 7.—ILLUSTRATING RULE 5.

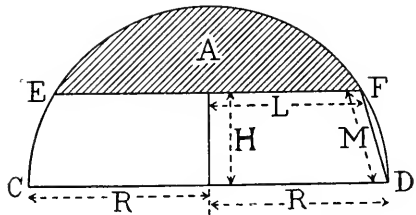

FIG. 8.—ILLUSTRATING THE FORMULA ON PAGE 181.

tion realized in the use of this last rule varies not only with the height of the segment, but also with the diameter of the circle of which the segment forms a part. In circles having a diameter from 30 in. to 102 in. inclusive, Rule 6 gives a result that is in error by less than two per cent., when the height of the segment is not less than three-tenths of the diameter of the circle.

The foregoing rules are all intended for the determination of the area of a segment to within a few per cent., when the application of a more exact method is not desired, either because the tables essential to the application of the more exact method are not at hand, or because the approximate rule (as in the case of Rule 6) is simpler, and quite good enough for the purpose in mind. It sometimes happens that the area of a segment is desired with a high degree of precision, however, when access cannot be had either to a trigonometric table, or to a table of segment areas such as the one given in *THE LOCOMOTIVE* for October, 1903, and already referred to. To meet this case, the editor of *THE LOCOMOTIVE* has devised an approximate formula which is new, so far as he is aware, and which gives results of remarkable precision. It is perhaps too complicated to be of value for every-day work, but the operations that it involves do not necessitate the use of any tables whatever, since they can all be performed by any person who is familiar with

the process of extracting the square root of a number. A table of logarithms and a table of the areas of circles can be used in connection with the formula, as a matter of convenience, but the employment of such tables is purely optional with the computer.

The lines that must be known in order to apply this more accurate approximate formula are shown in Fig. 8. The shaded area, A , here represents the segment whose area is to be determined, and CD is a diameter of the circle to which the segment belongs, CD being parallel to the base of the segment, EF . The lengths denoted by the various letters in the diagram will be apparent without explanation, with the possible exception of M , which is the distance, measured in a *straight line*, from F , the extremity of the base of the segment, to D , the corresponding extremity of the diameter CD . The lines R , H , L , and M can all be directly measured, if desired, but it is not necessary to measure more than two of them, since when two are known, the others can be calculated. For example, if we measure R , the radius of the circle, and H , the perpendicular distance from the center of the circle to the base of the segment, then we may calculate L and M as follows: For finding L we have the relation $L^2 = (R + H)(R - H)$; and when L has been obtained in this manner, we may find M from the relation $M^2 = 2R(R - L)$.

When we know R , H , L and M , either by direct measurement or otherwise, we may obtain a very accurate value of the area A (except when the height of the segment is very small) by means of the formula

$$A = 1.5707963R^2 - H\left(L - \frac{R}{3}\right) - \frac{4RM}{3}$$

The first term to the right of the sign of equality represents the area of the semi-circle, the number 1.5707963 being one-half of the familiar decimal number 3.1415926, by which the square of the radius must be multiplied, in order to obtain the area of the whole circle.

The area of a segment 18 in. high, in a circle 72 in. in diameter, is found, by this formula, to be 796.09 sq. in.; whereas the true area of such a segment, according to the table in the issue of THE LOCOMOTIVE for October, 1903, is 795.98 sq. in. In this case, therefore, the approximate formula last given is in error by only about 0.11 sq. in., or by about one-eightieth part of one per cent. The formula gives results that are still more accurate, when the segment is more nearly equal to a semi-circle.

Although the main purpose of the present article is to call attention to the foregoing approximate rules for computing the area of a circular segment, yet it appears desirable, in order to prevent misunderstanding, to add a few words of explanation concerning the method followed by the Hartford Steam Boiler Inspection and Insurance Company, in dealing with such segments, as they occur on the heads of horizontal tubular boilers.

Consider, for example, the boiler head that is represented in Fig. 9. This head is supposed to be 72 in. in diameter, from outside to outside of the flange, and the vertical distance from the upper row of tubes to the highest part of the shell is supposed to be 27 in. The part of the head that lies above the tubes is weak, because it is a flat surface; and braces must therefore be provided, in order to strengthen it. It is evident, however, that the holding power of the tubes will afford sufficient strength and stiffness to the head for a short

distance above the tubes, and it is also evident that there is a narrow strip around the head, near the flange, which is adequately supported and stiffened by the flange. It is difficult to say, with any approach to precision, how far into the head we may safely assume the supporting power of the tubes or the flange to extend; but it has been the practice of the Hartford Steam Boiler Inspection and Insurance Company, for many years past, to assume that the holding power of the tubes is adequate to provide for the support of a strip of the head two inches wide, and that the flange can be relied upon to support the head adequately, to a distance of three inches from the inner surface of the

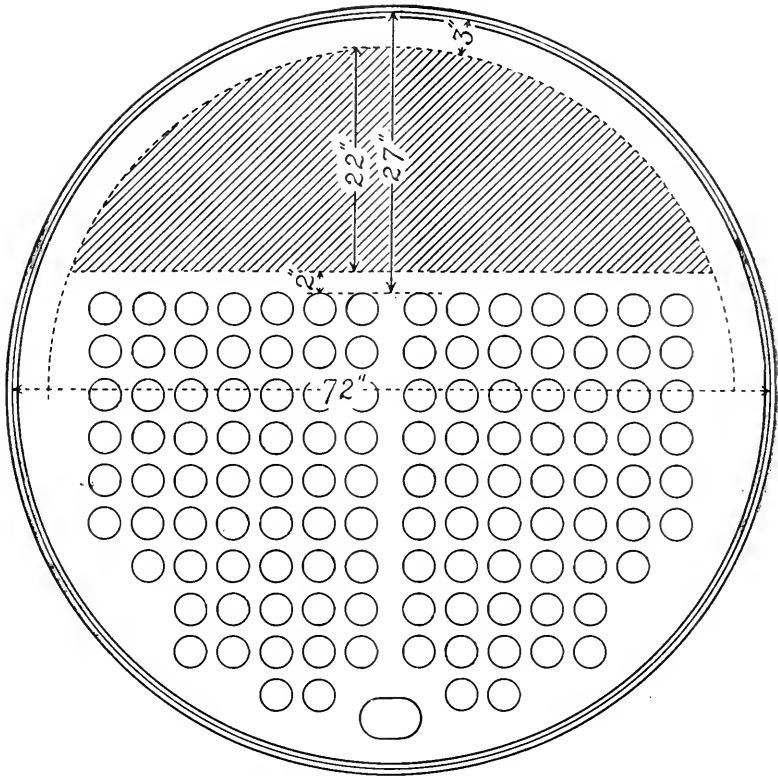

FIG. 9.—SHOWING THE SEGMENT THAT REQUIRES BRACING, ON A BOILER HEAD.

shell plate. This rule has worked well in our practice, and it affords what appear to be reasonable results in all cases.

According to the foregoing paragraph, it will be seen that the area that must be supported by braces does not consist of *all* that part of the head which lies above the tubes, but only of the portion that is shown shaded in Fig. 9. The part of the head that lies above the tubes has the form of a segment, 27 in. high, belonging to a circle 72 in. in diameter; but the area that requires bracing consists of a segment, 22 in. high, belonging to a circle 66 in. in diameter. Care must be exercised, in computing the bracing required upon boiler heads, to dis-

tinguish these two segments clearly. The same allowance is made for the supporting effect of the tubes and the flange, for all diameters of head; and a study of Fig. 9 will show that the following rule is to be applied in every case:

RULE: To find the height of the segment requiring bracing, subtract five inches from the distance from the tubes to the highest part of the shell; and to find the diameter of the circle to which the segment to be braced belongs, subtract six inches from the diameter of the boiler.

For example, to find the area that requires bracing when the head is 54 in. in diameter, and the shell is 24 in. above the tubes, we have to find the area of a segment which is 19 in. high, and which belongs to a circle that is 48 in. in diameter. Again, when the head is 96 in. in diameter, and the distance from the tubes up to the highest part of the shell is 32 in., the area that requires bracing consists in a segment which is 27 in. high, and which belongs

CORRECTION: On page 183, line 15, the number 1,575 should read 670; and in the following line the number 4,760 should read 1,579.

The Properties of Steam.

THIRD PAPER.—THE EXPERIMENTS OF RAMSAY AND YOUNG ON THE PRESSURE OF SATURATED STEAM.

The experiments that are to be considered in the present paper were made by Professor William Ramsay (now Sir William Ramsay), and Dr. Sydney Young, during the winter of 1887-88. Like Battelli, whose experiments upon water at temperatures below 240° C. were considered in our last paper. Ramsay and Young have investigated the properties of a number of different vapors, and the results of their labors are described in numerous memoirs that have been printed in the scientific periodicals from time to time. The numerical results that we shall cite in the present article are taken from the memoir entitled "On Some of the Properties of Water and of Steam," which will be found in the *Philosophical Transactions* of the Royal Society of London for 1892, Part A, Vol. 183, page 107. The apparatus that was used is not described in that place, however, as it was practically identical with that which had been employed by the same authors in previous researches upon alcohol and ether, and which was described and illustrated in the *Philosophical Transactions* for 1887, Part A, Vol. 178, page 57, under the heading, "A Study of the Thermal Properties of Ethyl Oxide."

Before proceeding to a description of the apparatus, it is only fair to say that while the results attained by Ramsay and Young are of great value, their paper is not characterized by the same clearness, and the same fullness of detail, that are to be observed in the memoirs of either Regnault or Battelli. For example, there is no word in their memoir as to the way in which the water employed was purified; and in justification of the criticism that we have just passed, this fact may be compared with the fullness with which Battelli describes the elaborate pains that he adopted to ensure purity. The only information in Ramsay and Young's paper, respecting the purity of the water that they used, appears in connection with a discussion of the solubility of the glass

distance above the tubes, and it is also evident that there is a narrow strip around the head, near the flange, which is adequately supported and stiffened by the flange. It is difficult to say, with any approach to precision, how far into the head we may safely assume the supporting power of the tubes or the flange to extend; but it has been the practice of the Hartford Steam Boiler Inspection and Insurance Company, for many years past, to assume that the holding power of the tubes is adequate to provide for the support of a strip of the head two inches wide, and that the flange can be relied upon to support the head adequately, to a distance of three inches from the inner surface of the

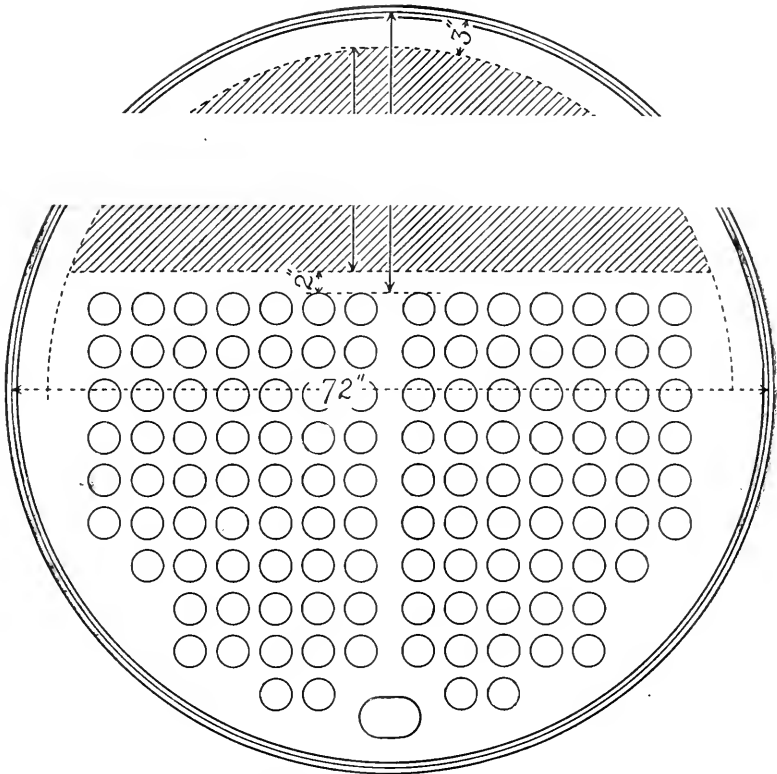

FIG. 9. — SHOWING THE SEGMENT THAT REQUIRES BRACING, ON A BOILER HEAD.

shell plate. This rule has worked well in our practice, and it affords what appear to be reasonable results in all cases.

According to the foregoing paragraph, it will be seen that the area that must be supported by braces does not consist of *all* that part of the head which lies above the tubes, but only of the portion that is shown shaded in Fig. 9. The part of the head that lies above the tubes has the form of a segment, 27 in. high, belonging to a circle 72 in. in diameter; but the area that requires bracing consists of a segment, 22 in. high, belonging to a circle 66 in. in diameter. Care must be exercised, in computing the bracing required upon boiler heads, to dis-

tinguish these two segments clearly. The same allowance is made for the supporting effect of the tubes and the flange, for all diameters of head; and a study of Fig. 9 will show that the following rule is to be applied in every case:

RULE: To find the height of the segment requiring bracing, subtract five inches from the distance from the tubes to the highest part of the shell; and to find the diameter of the circle to which the segment to be braced belongs, subtract six inches from the diameter of the boiler.

For example, to find the area that requires bracing when the head is 54 in. in diameter, and the shell is 24 in. above the tubes, we have to find the area of a segment which is 19 in. high, and which belongs to a circle that is 48 in. in diameter. Again, when the head is 96 in. in diameter, and the distance from the tubes up to the highest part of the shell is 32 in., the area that requires bracing consists in a segment which is 27 in. high, and which belongs to a circle that is 90 in. in diameter. Rule No. 6, above, gives 1,575 sq. in. in the first of these cases, and 4,700 sq. in. in the second, as the approximate area that must be supported by bracing.

The Properties of Steam.

THIRD PAPER.—THE EXPERIMENTS OF RAMSAY AND YOUNG ON THE PRESSURE OF SATURATED STEAM.

The experiments that are to be considered in the present paper were made by Professor William Ramsay (now Sir William Ramsay), and Dr. Sydney Young, during the winter of 1887-88. Like Battelli, whose experiments upon water at temperatures below 240° C. were considered in our last paper. Ramsay and Young have investigated the properties of a number of different vapors, and the results of their labors are described in numerous memoirs that have been printed in the scientific periodicals from time to time. The numerical results that we shall cite in the present article are taken from the memoir entitled "On Some of the Properties of Water and of Steam," which will be found in the *Philosophical Transactions* of the Royal Society of London for 1892, Part A, Vol. 183, page 107. The apparatus that was used is not described in that place, however, as it was practically identical with that which had been employed by the same authors in previous researches upon alcohol and ether, and which was described and illustrated in the *Philosophical Transactions* for 1887, Part A, Vol. 178, page 57, under the heading, "A Study of the Thermal Properties of Ethyl Oxide."

Before proceeding to a description of the apparatus, it is only fair to say that while the results attained by Ramsay and Young are of great value, their paper is not characterized by the same clearness, and the same fullness of detail, that are to be observed in the memoirs of either Regnault or Battelli. For example, there is no word in their memoir as to the way in which the water employed was purified; and in justification of the criticism that we have just passed, this fact may be compared with the fullness with which Battelli describes the elaborate pains that he adopted to ensure purity. The only information in Ramsay and Young's paper, respecting the purity of the water that they used, appears in connection with a discussion of the solubility of the glass

parts of the apparatus. In previous experiments upon ether (ethyl oxide), and upon the alcohols, lead glass was found to be the best material for the tubes of the apparatus; but in the case of water, lead glass was found to be out of the question, as it is appreciably soluble in water at high temperatures. Even at comparatively low temperatures, water will etch lead glass and render it partially opaque; so that the water becomes impure, and readings can be taken, through the glass, only with difficulty, or not at all. In experimenting upon water, Ramsay and Young, therefore, used tubes of greenish, boiler-gage glass, composed of 71.20 parts of silica, 14.99 of calcium oxide, 13.19 parts of potassium oxide, and a trace of ferrous iron. Regarding the resistant qualities of this glass, Ramsay and Young say: "Even after an exposure of several days to liquid water at 280° C. (536° Fahr.), only 0.7 per cent. of residue remained on evaporating the water. Inasmuch as *some* of the material of the glass is dissolved, however, the water cannot be considered to be absolutely pure, but the results may be given as the best attainable with water in contact with glass." It is to be presumed that care was exercised, to ensure a proper degree of purity in the water, previous to its introduction into the apparatus, so that the error due to impurity was at least within the limits of the unavoidable errors of experimental manipulation; but the absence of definite assurance upon this point is to be regretted. Any mineral matter that may have been present in the water, in solution would tend to *lower* the pressure of saturation, as observed at any given temperature.

The apparatus used by Ramsay and Young is shown, diagrammatically, in the accompanying illustration, which has been prepared partly from their own engraving, and partly (where the details are not actually shown by them) by the aid of their textual description.

The body of the apparatus consisted of a hollow iron cylinder, *A*, to which three vertical glass tubes, *G*, *H*, and *N*, were adapted, by means of the nozzles *D*, *E*, and *F*. The iron body, *A*, was firmly fixed in a horizontal position, and was filled with mercury when the apparatus was in use. One of its ends, *P*, was permanently closed, and the other was fitted with a removable cap, *B*, through which passed a screw, *C*, which worked in a packing of greased leather. To make the joint tight under pressure, the leather packing was surrounded by a mass of soft rubber, which was strongly pressed against the leather by screwing up the cap, *B*. The object of the screw, *C*, was to vary the pressure within the closed space consisting of the iron body and the attached glass tubes; rotation of the screw in one direction causing it to enter the body further, and so produce an increase of pressure, while rotation in the opposite direction caused it to recede, with a consequent reduction of pressure.

The three glass tubes, *G*, *H*, and *N*, were closed at their upper ends, while their lower ends were open and were submerged in the mercury within the hollow iron body of the apparatus. The tube, *N* (which we may conveniently call the "experimental tube"), was partially filled with mercury, the space above which was occupied by the water and steam whose properties were to be investigated. The tubes, *G* and *H*, served as pressure gages, and will be described subsequently. Ramsay and Young do not explain how the connections between the glass tubes and the iron body were made both strong and tight, and the method suggested in the engraving, where the tubes are supposed to be sur-

rounded by masses of soft rubber that are strongly compressed by turning up the iron caps on the nozzles, may not be the one that was actually employed. A knowledge of this detail, however, is not essential to a general understanding of the apparatus and its mode of operation.

Each of the tubes, *G*, *H*, and *N*, was carefully graduated, and its errors of graduation and of caliber were investigated by a method similar to that employed by Battelli. That is, each tube was first inverted, so as to bring its

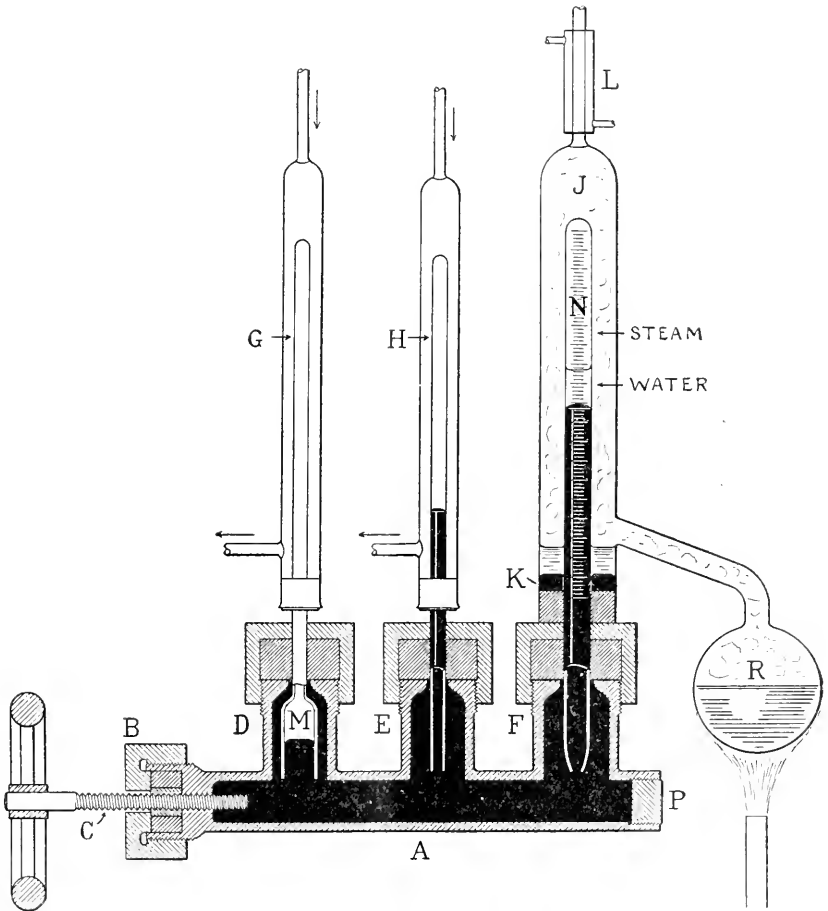

DIAGRAM OF RAMSAY AND YOUNG'S EXPERIMENTAL APPARATUS.

closed end downward, and successive weighed quantities of mercury were then poured into it. As the volume of a given weight of mercury is accurately known, the volumes included between the closed end of the tube, and the various graduation marks etched upon its side, could be ascertained with corresponding accuracy, by noting the level of the mercury surface in the tube, after each successive addition. (A process of this sort, by which the true

volume of a tube up to any given mark is ascertained, independently of any variations of caliber that may exist, is technically known as "calibration.")

As is well known, the surface of the mercury in a vertical tube like *G*, *H*, or *N*, is not plane and level, but is curved, with its convexity upward. In determining the volume of the upper part of such a tube, when the mercury column stands opposite a given graduation mark, it is therefore necessary to make proper allowance for the curved form of the mercury surface. This correction (known as the "meniscus correction") was applied by Ramsay and Young. Details concerning its evaluation are not given in their paper on water; but in the corresponding memoir on ethyl alcohol (*Philosophical Transactions*, 1886, Part 1, Vol. 177, page 123), which was investigated by methods practically identical with those employed for water, they say: "In correcting for the meniscus of the mercury, the meniscus was regarded as a hemisphere." The shape of the meniscus will vary with the diameter of the tubing, and with the actual tubing that was employed, the assumption of a hemispherical shape may have given sufficiently accurate results; but it would have been reassuring if data covering this point had been given in the memoir.

The pressures within the apparatus were determined by observing the degree of compression experienced by the air within the gage tubes, *G* and *H*. Consider, for example, the tube, *H*, which was used in measuring the lower pressures, and let us suppose that this tube were exactly filled with air, when the pressure within the apparatus was precisely equal to that of the atmosphere. Then if Boyle's law (see THE LOCOMOTIVE, January, 1900, page 1) were exactly true, it would follow that a pressure of three atmospheres would reduce the volume of the air within the tube to one-third of its original volume, and that a pressure of seven atmospheres would reduce it to one-seventh, and so on; always supposing that the temperature of the gage tube was not allowed to vary. Hence, if Boyle's law were rigorously accurate, we could take the pressures as inversely proportional to the volume of the air enclosed in the tube, *H*, so long as the temperature of *H* was kept constant. As a matter of fact, we know that Boyle's law, while very closely true at ordinary pressures and temperatures, is nevertheless not exact. Amagat has investigated its inaccuracy very carefully, and through a large range of pressure, at the constant temperature of 16° C. (60.8° Fahr.); and he has given a table by means of which the readings of an air-manometer like *H*, which is kept constantly at the temperature 16° C., can be reduced to true atmospheres. (For this table, see *Comptes rendus*, Vol. 99, page 1153. The figures given in an earlier part of the same volume are incorrect. The correct figures are also to be found in Preston's *Theory of Heat*, page 403.) It will be apparent, therefore, that the true pressures within the iron body of Ramsay and Young's apparatus could be obtained by observing the degree of compression experienced by the air in the tube, *H*, and then making use of Amagat's experimental data, *provided* the temperature of the air in the tube, *H*, were maintained continuously at 16° C., the temperature at which Amagat's measurements were performed. To ensure that the air in the gage should actually have this temperature, the tube *H* was enveloped by a narrow glass jacketing tube, through which a stream of water having the desired temperature was kept passing. The bulb of a small thermometer was immersed in the stream that emerged from the jacket, and the speed of the water-current was so regulated by trial, that there was

no sensible difference in temperature between the upper and lower ends of the gage tube.

The foregoing description of the gage, *H*, applies also to *G*, with one slight modification. At high pressures, the air in *H* would be compressed into a volume so small that the unavoidable errors due to the shape of the meniscus and other causes would constitute a sensible fraction of the total volume, and hence the gage could not be regarded as satisfactorily accurate at these high pressures. The second gage, *G*, was, therefore, fitted, at the bottom, with an enlargement, *M*, which served as an air reservoir. It will be seen that a pressure that would compress the air in *H* to (say) one-tenth of its original volume, would also compress the air in *G* to one-tenth of *its* original volume; but while mercury would thereby be forced, in *H*, up to within one-tenth of the length of the tube from the top, that in *G* would only be compressed until the space above the mercury became one-tenth of the combined volume of the tube and the reservoir. If the volume of the tube, *G*, above the lowest visible graduation mark, were made equal to one-tenth of the total volume of tube and reservoir combined, then when the air in *H* was compressed so that it occupied only one-tenth of the tube, *H*, the mercury in *G* would be just coming into view. Hence the volume of the air in *G* could be determined with satisfactory accuracy, when that in *H* was so reduced that the unavoidable experimental errors became serious. The graduations on the tubes, *G* and *H*, were studied and the tubes calibrated, by the same method that was used in connection with *N*. The calibration of the pressure-gage tubes is highly important, whether the apparatus is being used merely for the determination of the pressures of saturation corresponding to various given temperatures, or for the determination of the volume of saturated steam; while the calibration of the tube, *N*, is of great importance only when the density of the steam is being studied, and is of relatively small importance when the apparatus is in use merely for determining the pressures of saturation.

The experimental tube, *N*, was prepared for the experiments with great care, in order to ensure the absence of air from it; for the presence of even a measurable trace of air would affect the pressure-readings. The method adopted for introducing the water to be studied, so as to ensure the absence of air, is not described in Ramsay and Young's memoir on water; but as they state that the work was carried out similarly to that which they had previously performed upon ether, it is to be presumed that the filling of the experimental tube was performed in a similar manner, and the reader is therefore referred, for the details, to their paper upon ether.

The experimental tube being filled and placed in position, as shown in the engraving, it was next surrounded by a glass jacket, *J*, to the bottom of which it was adapted by means of a perforated rubber stopper, which fitted both the experimental tube and the jacket. A layer of mercury was placed in the jacket, at *K*, to protect the rubber stopper from any chemical action that the hot contents of the jacket might have upon it.

The glass jacket, *J*, surrounding the experimental tube, was provided with a side bulb, *R*, containing a liquid that boiled, under a given pressure, at a known temperature; and at the top of the jacket, *J*, there was an escape pipe, fitted with a small condenser, *L*, which served to condense the vapor rising from the bulb, *R*, and cause it to trickle back into the jacket. Among the

liquids used in the bulb, *R*, and the jacket, *J*, were bromobenzene, aniline, and methyl salicylate, the boiling points of which, on the scale of the air-thermometer, had been previously investigated, under various pressures, by Ramsay and Young, as described in a paper published in the *Journal of the Chemical Society*, Vol. 47, page 640. The pressure at which the jacketing liquid boiled could be regulated by means of a gage attached to the escape pipe at the top of the jacket, and a barometer; so that in carrying out the experimental work it was feasible to cause the jacketing liquid to boil at any desired pressure (within limits, of course), and hence to maintain the water and vapor within the experimental tube at a definite known temperature on the scale of the air-thermometer.

In a word, it will be plain that the volume of the interior of the apparatus (and hence the pressure) could be altered by means of the screw, *C*, as shown; that the pressures could be read either by the high pressure gage, or by the low pressure one, and sometimes by both; and that the experimental tube could be maintained at a constant temperature, which was known on the scale of the air-thermometer.

No statement is made, in the memoir upon water, as to the degree of accuracy that the experimenters are disposed to assign to their measurements of temperature; but in their similar memoir upon alcohol (*Philosophical Transactions*, 1886, Part I, Vol. 177, page 123) they say of their temperature measurements in that particular research, "We can state with confidence that at the highest temperature employed (246° C.) the absolute error does not amount to two or three-tenths of a degree; and the temperature can be altered with certainty through 0.05° C. by alteration of the pressure under which the liquid is boiling."

In the present paper we shall give the numerical results obtained by Ramsay and Young for the pressures of saturation only; for although they also used the same apparatus for the determination of the density of saturated steam, this part of the subject requires special discussion, and its consideration will therefore be reserved until we come to the consideration of the density of steam, in a later article.

It is evident that when the apparatus herein described was mounted as shown, and all was ready for the observations to begin, the total quantity of water present, either as liquid or as vapor, in the experimental tube, was fixed; but that the relative space occupied by steam and by liquid water could easily be altered. The temperature of the tube being constant, if the screw, *C*, were turned so as to reduce the volume of the interior of the apparatus, the space occupied by the steam in the upper part of the experimental tube would thereby become reduced, some of the steam condensing to water at the same temperature; and, conversely, if the screw, *C*, were turned in the opposite direction, some of the water in the experimental tube would evaporate, and the space occupied by the steam would be increased. In carrying out the actual experimental work, the relative volumes occupied by the steam and water were changed, in this manner, at each temperature; so that the final experimental result given for each temperature is the average of from three to ten separate determinations of the saturation pressure, made with widely varying proportions of water and vapor in the experimental tube. It is usually taught that the pressure of saturation is absolutely independent of the relative quantities of

steam and water that may be present, and Ramsay and Young found that this is practically true, so long as the quantity of water present is not too small. They found, however, that when the quantity of water present in the liquid form is so small that the space above the mercury in the experimental tube is almost entirely filled with vapor, the pressure of saturation is not exactly the same as it is when more water is present. This point was referred to in our last article in this present series, in which Battelli's work is described. Ramsay and Young state that the pressure of saturation, with only a trace of liquid water present, is, on the whole, smaller than that which is obtained with plenty of the liquid in the tube, and this they attribute to the adherence of the vapor to the sides of the experimental tube. So far as the reality of the difference is concerned, and its sign, Ramsay and Young and Battelli are in accord; but Battelli does not believe that the explanation is to be found in the adherence of the vapor to the sides of the experimental tube, and in fact he appears to believe that this explanation has been experimentally disproved, and that the true explanation must be sought elsewhere. We cannot enter into this discussion at present, however, and we shall merely give the numerical results obtained by Ramsay and Young, for the case in which liquid water was present in considerable quantity.

In the accompanying table these results are collected, and little need be said concerning them, in addition to the general description of the apparatus and the experiments, which has been given above. The first column of the table gives the temperatures at which the various observations were made, and the second gives the observed pressures of saturated steam at those respective temperatures. The numbers in the second column are the ones that were obtained by taking the average of from three to ten separate experimental results, and hence each of these numbers in the second column is to be regarded as the outcome of a short series of experiments. It will be seen that in several cases there were two series of experiments made at one temperature; and in one instance (namely, at 210° C.) there were three series taken at the same temperature. The third column contains, for each temperature, the pressure that Ramsay and Young finally adopted as the observed pressure at that temperature. When there was only one series of observations made at any one temperature, the numbers in columns two and three are, of course, identical. Where more than one series of measurements was made, the apparent intention of the observers was, to adopt the average of the several separate series. At the temperatures 210° and 220° , the concluded values are the actual averages of the corresponding numbers in the second column. At 150° the average of the two separate experimental results is 3,567, instead of 3,568 as given by Ramsay and Young. We have retained their number for this temperature, because the difference is too small to be of any practical importance. In the case of the temperature 180° , Ramsay and Young made a manifest arithmetical blunder, for they give the concluded value of the pressure as 7,487 millimeters, not only in their table of individual observations, but also in the table of general results on page 112 of the memoir. Inspection of this last-mentioned table shows, however, that in comparing their own observed pressures with the pressures as computed by various formulas that are cited, they have taken the observed value at 180° as 7,478; and we have adopted this latter value as the correct mean for 180° , since it agrees with the average of the two separate experimental

series given in the second column of our table. The series that is marked with a star in our table (for the temperature 220°) is accompanied, in the original, by the legend "End of work." No explanation of this term is given, and we assume that it merely means that the series so designated was the last that was taken, its completion marking the termination of the research, so far as the observation of the pressures of saturation was concerned.

PRESSURE OF SATURATED STEAM, AS OBSERVED BY RAMSAY AND YOUNG.

Temperature (Centigrade) by air thermometer.	Mean observed pressure. (Millimeters of mercury.)	Pressure adopted by Ramsay and Young. (Millimeters of mercury.)	Substance in jacket of experimental tube.
120°	1,484	1,484	Not stated.
130°	2,019	2,019	Not stated.
140°	2,694	2,694	Not stated.
{ 150°	3,553 }	3,568	{ Bromobenzene. Aniline.
{ 150°	3,581 }		
160°	4,652	4,652	Not stated.
170°	5,937	5,937	Not stated.
{ 180°	7,518 }	7,478	{ Aniline. Methyl salicylate.
{ 180°	7,437 }		
190°	9,403	9,403	Not stated.
200°	11,625	11,625	Not stated.
{ 210°	14,241 }	14,240	{ Not stated. Not stated. Not stated.
{ 210°	14,255 }		
{ 210°	14,223 }		
{ 220°	17,329 }	17,365	{ Not stated. Not stated.
{ 220°	17,401* }		
230°	20,936	20,936	Not stated.
240°	25,019	25,019	Not stated.
250°	29,734	29,734	Not stated.
260°	35,059	35,059	Not stated.
270°	41,101	41,101	Not stated.

* Designated by Ramsey and Young as "End of Work."

MESSRS. H. R. Mann & Co., general agents of the Hartford Steam Boiler Inspection and Insurance Company in its Pacific Coast department, who were forced, by the great fire, to remove to Oakland, Cal., have now returned to San Francisco, where they have taken new and more commodious quarters in the Merchants' Exchange Building.

Hartford Steam Boiler Inspection and Insurance Company.

ABSTRACT OF STATEMENT, JANUARY 1, 1907.

Capital Stock, \$500,000.00.

ASSETS.

	Par Value.	Market Value.
Cash in office and in Bank,		\$143,952.21
Premiums in course of collection (since Oct. 1, 1906),		173,419.47
Interest accrued on Mortgage Loans,		26,448.03
Loaned on Bond and Mortgage,		1,047,720.00
Real Estate,		9,450.00
State of Massachusetts Bonds,	\$100,000.00	92,000.00
County, City, and Town Bonds,	326,000.00	340,330.00
Board of Education and School District Bonds,	34,000.00	35,800.00
Drainage and Irrigation Bonds,	3,000.00	3,000.00
Railroad Bonds,	1,439,000.00	1,582,090.00
Street Railway Bonds,	62,000.00	62,250.00
Miscellaneous Bonds,	87,500.00	87,665.00
National Bank Stocks,	41,800.00	60,970.00
Railroad Stocks,	194,200.00	259,201.00
Miscellaneous Stocks,	65,500.00	53,920.00
	\$2,353,000.00	
Total Assets,		\$3,978,245.71

LIABILITIES.

Re-insurance Reserve,		\$1,931,847.29
Losses unadjusted,		26,250.80
Commissions and brokerage,		34,689.89
Surplus,	\$1,485,457.73	
Capital Stock,	500,000.00	
Surplus as regards Policy-holders,	\$1,985,457.73	1,985,457.73
Total Liabilities,		\$3,978,245.71

On December 31, 1906, the HARTFORD STEAM BOILER INSPECTION AND INSURANCE COMPANY had 95,310 steam boilers under insurance.

L. B. BRAINERD, Pres. and Treas. FRANCIS B. ALLEN, Vice-President.
 J. B. PIERCE, Secretary. C. S. BLAKE, 2d Vice-President.
 L. F. MIDDLEBROOK, Assistant Secretary.
 E. J. MURPHY, M. E., Consulting Engineer.
 F. M. FITCH, Auditor.

BOARD OF DIRECTORS.

FRANK W. CHENEY, Treas. Cheney Brothers Silk Manufacturing Co.	LUCIUS F. ROBINSON, Attorney, Hartford, Conn.
CHARLES M. BEACH, of Beach & Co.	JOHN O. ENDERS, U. S. Bank, Hartford, Conn.
GEORGE BURNHAM, Baldwin Locomotive Works, Philadelphia.	LYMAN B. BRAINERD, President and Treasurer, Hartford Steam Boiler Inspection and Insurance Co.
C. C. KIMBALL, President Smyth Manufacturing Co., Hartford, Conn.	MORGAN B. BRAINARD, Asst. Treasurer, Aetna Life Insurance Co.
PHILIP CORBIN, P. & F. Corbin, New Britain, Ct.	F. B. ALLEN, Vice-Prest., Hartford Steam Boiler Inspection and Insurance Co.
GEORGE A. FAIRFIELD, Ex-Prest. Hartford Machine Screw Co.	CHARLES P. COOLEY, Treas. The Fidelity Company, Hartford, Conn.
J. B. PIERCE, Secretary Hartford Steam Boiler Inspection and Insurance Co.	ARTHUR L. SHIPMAN, Corporation Counsel, Hartford, Conn.
ATWOOD COLLINS, Prest. Security Co., Hartford, Conn.	

Incorporated
1866.

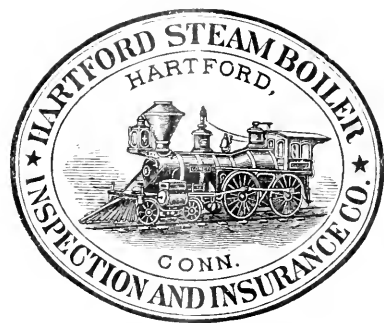

Charter Per-
petual.

The Hartford Steam Boiler Inspection and Insurance Company

ISSUES POLICIES OF INSURANCE COVERING
ALL LOSS OF PROPERTY

AS WELL AS DAMAGE RESULTING FROM
**LOSS OF LIFE AND PERSONAL INJURIES DUE TO STEAM
BOILER EXPLOSIONS.**

*Full information concerning the Company's Operations can be obtained at
any of its Agencies.*

Department.	Representatives.	Offices.
NEW YORK, . . .	C. C. GARDINER, JR., Manager, R. K. McMURRAY, Chief Inspector,	New York City, N. Y., 100 William St.
NORTHEASTERN, . . .	C. E. ROBERTS, Manager, F. S. ALLEN, Chief Inspector,	Boston, Mass., 101 Milk St. Providence, R. I., 29 Weybosset St.
PENNSYLVANIA, . . .	CORBIN & GOODRICH, Gen. Agents, Wm. J. FARRAN, Chief Inspector,	Philadelphia, Pa., 432 Walnut St.
MARYLAND, . . .	LAWFORD & MCKIM, Gen. Agents, R. E. MUNRO, Chief Inspector,	Baltimore, Md., 13-14-15 Abell Bldg. Washington, D. C., 511 Eleventh St., N. W.
SOUTHEASTERN, . . .	W. S. HASTIE & SON, Gen. Agts., W. M. FRANCIS, Chief Inspector,	Charleston, S. C., 44 Broad St.
SOUTHERN, . . .	LOUIS V. CLARK & Co., Gen. Agents, H. E. STRINGFELLOW, Chief Inspector,	Birmingham, Ala., 214-216 N. 20th St.
GULF, . . .	PETER F. PESCUDE, General Agent, R. T. BURWELL, Chief Inspector,	New Orleans, La., 818 Gravier St.
HOME, . . .	E. H. WARNER, General Agent, H. C. LONG, Special Agent, F. H. WILLIAMS, JR., Special Agent, F. S. ALLEN, Chief Inspector,	Hartford, Conn., 650 Main St.
SOUTHERN CONN.,	W. G. LINEBURGH & SON, Gen. Agts.,	Bridgeport, Conn., 1 Sanford Building.
PITTSBURG, . . .	JAMES W. ARROTT, LTD., Gen. Agt., BENJAMIN FORD, Chief Inspector,	Pittsburg, Pa., 401 Wood Street.
NORTHERN OHIO,	C. A. BURWELL, General Agent, H. A. BAUMHART, Chief Inspector,	Cleveland, Ohio, 337 Superior Av., N. W.
NORTHWESTERN,	H. M. LEMON, Manager, JAMES L. FOORD, Chief Inspector, C. B. PADDOCK, Asst. Chief Inspector,	Chicago, Ill., 169 Jackson St.
SOUTHWESTERN,	VICTOR HUGO, Manager, VICTOR HUGO, Chief Inspector,	St. Louis, Mo., 319 North Fourth St.
WESTERN, . . .	THOS. F. DALY, General Agent, T. E. SHEARS, Chief Inspector,	Denver, Col., 210-215 Ta- bor Opera House Bldg.
PACIFIC COAST, . . .	H. R. MANN & Co., General Agents, J. B. WARNER, Chief Inspector,	San Francisco, Cal., Merchants' Ex. Bldg.

The Locomotive

PUBLISHED BY THE HARTFORD STEAM BOILER INSPECTION AND INSURANCE COMPANY.

VOL. XXVI.

HARTFORD, CONN., JULY, 1907.

No. 7.

Three Notable Boiler Explosions.

The engravings presented herewith illustrate three boiler explosions which it is believed will be of interest to readers of THE LOCOMOTIVE. The boiler which is shown in Figs. 1 and 2 exploded, some time ago, on the steamer *City of Trenton*, on the Delaware River, opposite Hampton Court, near Philadelphia, Pa. This explosion was attended by a fearful loss of life, as the main and upper decks of the steamer were blown into the river, carrying many persons with

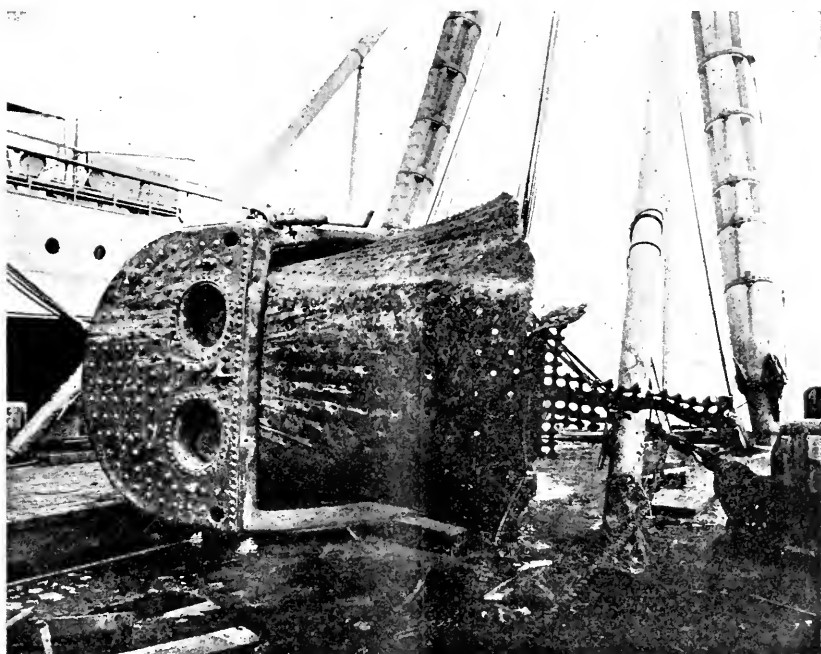

FIG. 1. — THE EXPLODED BOILER OF THE "CITY OF TRENTON."

them. The total number of persons killed outright, or injured so badly that they died within a few days, was twenty-seven; and the number of those that were injured but not killed, while not accurately known, was in the neighborhood of fifty.

The *City of Trenton* was a light-draft boat, built expressly for navigating the shoal water between Bordentown and Trenton, N. J. She had twin screws, and was fitted with two vertical, two-cylinder engines. She had two boilers of

the locomotive type, placed in a compartment forward of the engine compartment, and situated about amidships. The front ends of the boilers faced the bow of the boat, and their rear ends were connected to a smoke-box and one stack.

The boiler that exploded was on the port side of the boat, and a subsequent inspection showed that the starboard boiler was not seriously disturbed, and that it was, in fact, comparatively uninjured. The port boiler was blown from the boat, apparently going up furnace-end first, and turning a somersault in the air. It fell into the river, but it was shortly raised from the river bottom, and placed on one of the piers of Neafe & Levy's shipyard, where it was examined

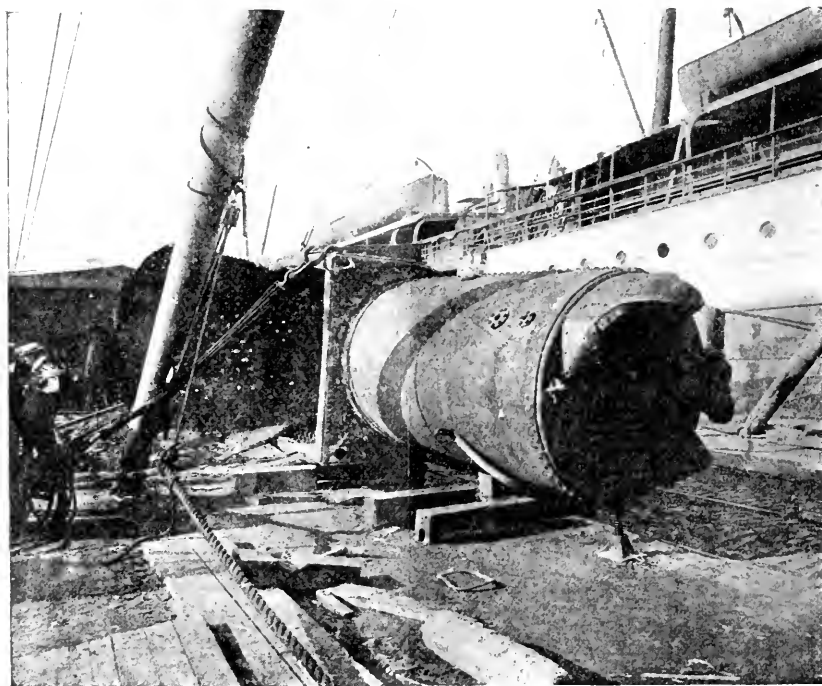

FIG. 2.—THE EXPLODED BOILER OF THE "CITY OF TRENTON."

by the coroner's jury, by the officials of the United States Government, and by those of the city of Philadelphia, in the investigations that followed. The engravings show the boiler as it appeared on the pier.

The explosion consisted in the failure of the crown-sheet. This sheet, which is seen protruding from the furnace in both the illustrations, was blown downward and forward, carrying with it a portion of the upper part and center of the tube-sheet, and striking against the front sheet of the furnace. It thus turned practically inside out, and a part of it, with a piece of the tube-sheet attached, projected six feet or more below the bottom of the water-leg.

When the crown-sheet came down, it pulled away from the riveted screw-stays entirely, leaving them attached to the jaw braces, which still remained

fastened to the inside of the outer shell. Many of the crown-bolt holes in the crown-sheet were oblong after the explosion, their length, in some cases, being as much as $3\frac{1}{16}$ inch greater than the original diameter of the hole. "It would seem to me," said one expert, who examined the boiler on our behalf, "that the sheet had bent down between the bolts, spreading the hole on the upper side, leaving only one or two threads on the lower side of the sheet (together with the riveted head) to hold before it let go. It would appear that the sheet let go at the rear end, starting at about the center line of the boiler."

From testimony given in the course of the investigations, it appeared that the pressure observed on the boilers was about 150 pounds per square inch, a few



FIG. 3.—GENERAL VIEW OF THE DESTROYED POWER PLANT.

minutes before the explosion. Two months before the exploded boiler had withstood a steam pressure of 175 pounds, and a hydrostatic pressure of 203 pounds.

The coroner who held the inquest was unusually fortunate in the selection of the jury, which consisted of six men who were all familiar with boiler construction and management, the foreman being Samuel H. Vauclain, general superintendent of the Baldwin Locomotive Works. The jury was of the opinion that the failure was due to lack of water on the crown-sheet. At the inquest the fusible plug played a conspicuous part. Instead of being filled with Banca tin, which melts at 442° to 446° Fahr., and which, since it is an element, is not liable to experience a change in melting point from mere continued exposure to heat, it appeared that the plug in the exploded boiler was filled with an alloy of antimony, tin, and lead, which was supposed to melt at 436° Fahr. An actual

test of the metal remaining in the plug showed that it did not melt until a temperature of 695° Fahr. was attained. (Pure *lead* melts at from 608° to 618° .) As the metal in the plug had been partially melted out previous to the explosion, the jury concluded that the plug had been exposed, in the boiler, to a temperature approximating to 695° , and hence that the water over the crown-sheet must have been low.

In Figs. 3 and 4 we illustrate the boiler explosion which destroyed the power plant of the Columbus, Delaware & Marion Railway Company, at Marion, Ohio, on August 22, 1906. The boiler that exploded was of the sectional, water-tube type, and the explosion consisted in the blowing out of the head of a mud drum, which had been more or less weakened by corrosion. The pres-

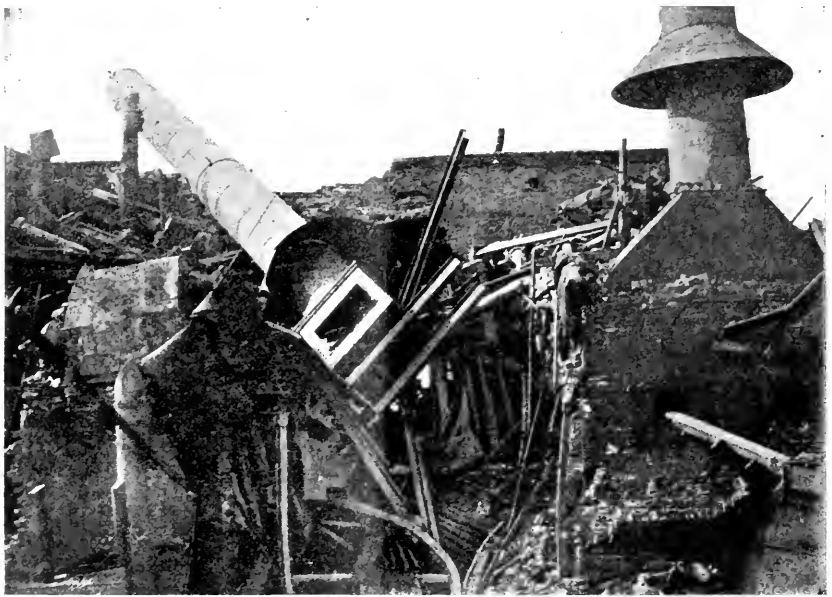

FIG. 4. —DETAIL VIEW OF THE DESTROYED POWER PLANT.

sure carried at the time was about 140 pounds per square inch, which was considered to be quite safe. The explosion wrecked the plant and the machinery, the ruins consisting of a mass of bricks and a tangle of twisted beams, for the removal of which a hoisting engine had to be employed. Fortunately no person was killed, but four were more or less seriously injured. The estimated property loss was about nine thousand dollars. Fig. 3 gives a general view of the ruins, and Fig. 4 gives another view, showing a portion of the ruins on a larger scale.

An explosion widely different in character from either of the preceding is illustrated in Fig. 5. The boiler that is here shown was made of cast-iron, and was used for heating purposes only. It was one of a nest of two, both of which are seen in the illustration, although only one exploded. The boilers

were located in the basement of St. Joseph's Orphan Asylum, Seventh and Spruce streets, Philadelphia, Pa.; and as the building was occupied by many little children, the accident might easily have resulted in a fearful loss of life. Forty little girls were about to file into a large sewing-room on the first floor, when the boiler gave way and wrecked the room that they were about to enter. Another group of twenty little girls, about to file down from one of the upper floors, was badly frightened by the noise and the shock, but discipline was

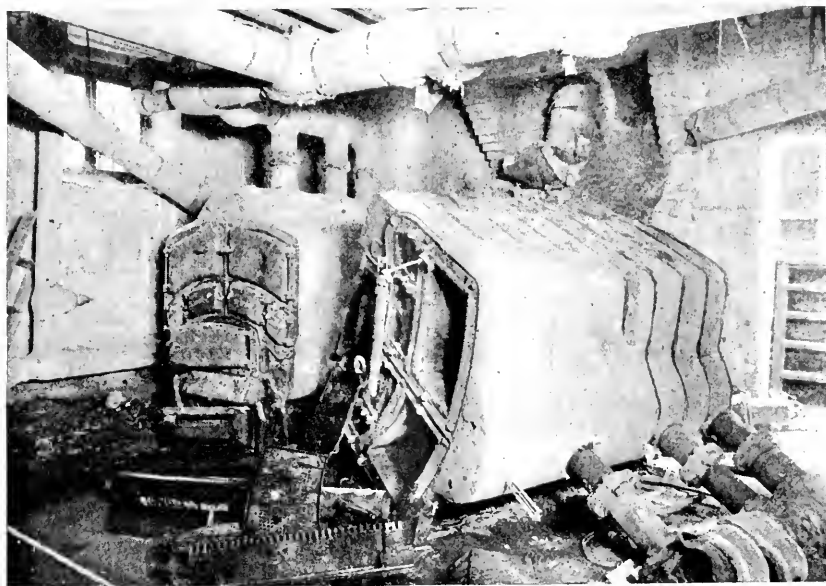

FIG. 5.—ORPHAN ASYLUM BOILERS AFTER THE EXPLOSION.

maintained, and the little ones were conducted to another part of the building, without panic. No inmate of the institution was injured, but a boy, passing on the street, was somewhat burned by escaping steam. The exploding boiler was thrown over on its side, and the piping by which it had been connected to the steam mains was, of course, ruptured. The explosion damaged the building to the extent of several thousand dollars. Fire also broke out, but the flames were extinguished before they had done any great additional damage.

Boiler Explosions.

APRIL, 1907.

(128.)—A tube ruptured, April 1, in a water-tube boiler at the Oak Park Construction Co.'s plant, Oak Park, Ill.

(129.)—A heating boiler exploded, April 1, in the basement of the Delta Phi lodge, Ithaca, N. Y.

(130.) — On April 1 the tube-sheet of a water-tube boiler fractured at the Skandia Furniture Co.'s plant, Rockford, Ill.

(131.) — A boiler exploded, April 3, in William Clarkson's feather renovating establishment, Louisville, Ky., badly wrecking the place.

(132.) — On April 3 a tube ruptured in a boiler at the plant of the Lee Paper Co., Vicksburg, Mich.

(133.) — A tube ruptured, April 4, in a water-tube boiler at the plant of the Simonds Manufacturing Co., Chicago, Ill. J. Vena, a coal passer, was scalded.

(134.) — On April 5 a tube ruptured in a water-tube boiler at Gustave Benjamin's rolling mill, Elmira, N. Y. John Nugent was injured.

(135.) — A boiler exploded, April 6, in the Penn Shovel Works, Warren, Ohio. Joseph Bell and Frank Rummel were injured.

(136.) — Six cast-iron headers fractured, April 6, in a boiler at the plant of the Pressed Steel Car Co., Allegheny, Pa.

(137.) — On April 8 an elbow ruptured on a blowoff pipe at the Standard Sanitary Manufacturing Co.'s plant, Allegheny, Pa. Joseph Schmidt was scalded.

(138.) — A slight boiler accident occurred, April 8, at the Emerson-Smith Co.'s plant, Beaver Falls, Pa.

(139.) — On April 8 an accident happened to the boiler of Emil Weissbrod & Sons' pocketbook factory, Greenfield, Mass.

(140.) — The boiler of locomotive No. 2618, on the Southern Pacific railroad, exploded, April 10, just outside of tunnel No. 12, on the Tehapi mountain, near Bakersfield, Cal. Engineer Robert Machin and fireman Vaughn were instantly killed, and brakeman H. R. Jones was badly injured.

(141.) — The boiler of locomotive No. 2703, on the Southern Pacific railroad, exploded, April 10, while leaving the roundhouse at Mojave, Cal. H. B. Earnest and D. Shea were killed.

(142.) — On April 10 a number of tubes pulled out of the drum of a water-tube boiler at the plant of the De Kalb-Sycamore Electric Co., De Kalb, Ill.

(143.) — A cast-iron header fractured, April 10, in a boiler at the Lighting Station of the City of Grand Rapids, Grand Rapids, Mich.

(144.) — A boiler exploded, April 11, in Wurtzbaugh & Sons' sawmill, seven miles west of Jefferson, Tex. Otto Hargrave and William Mott were killed, and three other men were injured. The mill was wrecked.

(145.) — The boiler of Ezra Householder's portable sawmill exploded, April 11, on the Thomas Wells farm, near Costonia, Ohio. John Householder was fatally injured, and the mill was destroyed.

(146.) — A rupture occurred, April 12, in one of the boilers of the Shrove Mills, Tiverton, R. I.

(147.) — A small boiler exploded, April 14, in the shoe repairing shop of John Paris, Jr., Wilmington, Del.

(148.) — A tube burst, April 14, on the dredger *George W. Allen*, at Key

West, Fla. Jose Inado and Manuel Agras were killed, and eight other persons were injured.

(149.) — On April 15 a boiler exploded in the Lemon Lumber Co.'s planing mill, at Lemonville, near Orange, Tex. Robert Mosely was injured.

(150.) — A boiler exploded, April 16, in H. K. Rhoads' fertilizer plant, near Pottstown, Pa.

(151.) — On April 18 a tube ruptured in a water-tube boiler in the B. F. Goodrich Co.'s plant, Akron, Ohio.

(152.) — The boiler of a traction engine exploded, April 19, at West Walworth, near Rochester, N. Y. Chester Smith was instantly killed, and George Dreschel, Frank Young, and Frank Ford were badly injured.

(153.) — A tube ruptured, April 20, in a water-tube boiler at the Diamond Crystal Salt Co.'s plant, St. Clair, Mich.

(154.) — On April 20 a boiler exploded in A. C. Bishop's sawmill, at Conn. near Mount Forest, Ontario. Norman Gillstorff and Patrick J. Cannon were killed, and A. C. Bishop was seriously injured.

(155.) — The furnace of a vertical boiler collapsed, April 22, in the Gary Manufacturing Co.'s plant, at Alberton, Md.

(156.) — A boiler exploded, April 23, in a flouring mill at Smith's Landing, five miles below Morgantown, W. Va.

(157.) — A boiler exploded, April 23, in J. McGuire's cabinet works, Los Angeles, Cal.

(158.) — On April 24 a boiler exploded in the Shoal Creek Lumber Co.'s plant, Shoal Creek, Ala.

(159.) — A boiler, or a similar vessel used at high pressure, exploded, April 24, in the American Industrial Manufacturing Co.'s plant, at Alexandria, Ind. Benjamin Downey was fatally injured, and Ora Johnson and J. M. Bemer were badly burned. The property loss was estimated at \$25,000.

(160.) — A boiler exploded, April 24, at the Sumner Lumber Co.'s plant, at Zuber, near Kendrick, Fla. Engineer D. S. Bowers was instantly killed, and the boiler room was wrecked.

(161.) — A hot-water boiler exploded, April 24, in Hotel Monnet, Evanston, Ill., partially wrecking four rooms on the first floor of the building. Frank Kellog, a student at Northwestern University, was badly injured.

(162.) — Two cast-iron headers ruptured, April 25, in a water-tube boiler in the Philadelphia Rapid Transit Co.'s power house, at 13th and Mount Vernon streets, Philadelphia, Pa.

(163.) — On April 25 a boiler exploded in H. J. Case's sawmill, near Bradford, N. Y. Silas Dicksey was instantly killed.

(164.) — A number of cast-iron headers fractured, April 26, in a water-tube boiler at Girard College, Philadelphia, Pa.

(165.) — The boiler of a Wabash freight locomotive exploded, April 27, near O'Fallon, Mo., 33 miles from St. Louis. Engineer Paul Klinard, fireman Frank Appleby, and brakeman George E. Brown were killed, and conductor Nicholas Dessert was fatally injured. The locomotive was totally destroyed.

(166.) — A boiler belonging to the Producers' Oil Company exploded, April 28, at the Little Jap Pettie lease well No. 7, Saratoga, Tex., painfully injuring fireman Patrick Mathews.

(167.) — The boiler of Baltimore & Ohio freight locomotive No. 2299 exploded, April 28, on the Parkersburg branch, just west of Flemington, W. Va. Engineer Charles H. Bowen and fireman W. B. Garey were killed.

(168.) — A locomotive boiler exploded, April 29, at Wanakena, N. Y., on the Cranberry Lake railroad, which is operated by the Rich Lumber Co. as a logging road. Ernest Storin and Harris Kessel were killed, and Burt Keyes, William Reynolds, Edwin Ackerman, Judson Ackerman, and Arthur Remington were injured.

(169.) — A boiler used for pumping purposes exploded, April 29, on Albert Levee's rice plantation, Burton, La., fatally injuring Mr. Levee.

(170.) — A tube ruptured, April 30, in a water-tube boiler at the plant of the Star Furnace Co., Jackson, Ohio.

(171.) — On April 30 a boiler exploded in the Raymond Shingle Co.'s mill, at Raymond, Wash. Night watchman George Franzer was instantly killed, and the boiler and engine rooms were demolished. The property loss was estimated at \$10,000.

MAY, 1907.

(172.) — On May 1 the boiler of a Santa Fé switching locomotive exploded in the yards at Bakersfield, Cal.

(173.) — A tube ruptured, May 3, in a water-tube boiler in J. E. Baum's department store, Omaha, Neb.

(174.) — A boiler belonging to C. McClelland exploded, May 4, near Bartlesville, I. T.

(175.) — A boiler exploded, May 4, near Tulsa, I. T., on the Buck Self oil lease, owned by the Prairie Oil and Gas Co.

(176.) — On May 7 a boiler exploded on the George Crozier farm, in Eagle township, near Findlay, Ohio. A. W. Apple and Charles Henning were severely injured.

(177.) — Hermann Kurbis was killed, May 7, by the explosion of a boiler in the Kurth Brewing Co.'s plant, at Columbus, Wis.

(178.) — On May 8 a tube ruptured in a water-tube boiler at the Alpha Portland Cement Co.'s plant, Martins Creek, Pa. Antonio Pulgir was injured.

(179.) — A tube ruptured, May 9, in a water-tube boiler at the B. F. Goodrich Co.'s rubber works, Akron, Ohio. Isaac George was injured.

(180.) — According to the Houston, Tex., *Post*, Charles I. Miller, of Palestine, Tex., was killed, on or about May 12, in a boiler explosion in Indian Territory. We have not been able to obtain further particulars. The explosion was apparently not identical with either Nos. 174 or 175, above, as there was no loss of life reported in either of those two.

(181.) — A cast-iron header fractured, May 12, in a water-tube boiler

at the power house of the Philadelphia Rapid Traction Co., 13th and Mount Vernon streets, Philadelphia, Pa.

(182.) — A boiler exploded, May 13, in the laundry of the Parrott House, Schoharie, N. Y. Sarah Vroman and Charles Palen were seriously injured, and two other persons received minor injuries.

(183.) — On May 13 a slight boiler explosion occurred in the Arkwright Mills, at Spartanburg, S. C.

(184.) — A cast-iron sectional heating boiler ruptured, May 13, in the office building at Nos. 2 to 4 Park Square, Boston, Mass.

(185.) — A water-tube boiler exploded, May 16, in the power house of the Brooklyn Heights Railroad Co., 2d street and 3d avenue, Brooklyn, N. Y. Nicholas Marcaro was killed, and G. Fontano was injured. One of the headers pulled away from the tubes, and was thrown through the front door of the boiler.

(186.) — A boiler exploded, May 17, in J. A. Petty's planing mill, at Sycamore, Ohio. Charles Ludwig was fatally injured, and Carl Babcock, Charles Wolfred, George Hoover, and C. C. Kitchinaso received injuries from which they will recover. The boiler house was completely wrecked.

(187.) — Eight cast-iron headers fractured, May 18, in a water-tube boiler at the Colin Gardner Paper Co.'s plant, Middletown, Ohio.

(188.) — A boiler exploded, May 20, in the power house of the Chicago City Railway Co., 92d street and Ewing avenue, Chicago, Ill. Joseph Kopki and William Field were seriously scalded.

(189.) — On May 20 a blow-off pipe failed on a boiler at the Jesup & Moore Paper Co.'s plant, Wilmington, Del., injuring Charles Foreman.

(190.) — A boiler exploded, May 21, in H. B. Schweinegruber's sawmill, at Datto, eight miles from Corning, Ark. John Moore was killed, and David Sullivan, DeWitt Dickens, Noah Brinker, and H. L. Schweinegruber were injured. The mill was wrecked, and the property loss was estimated at \$25,000.

(191.) — On May 21 a boiler exploded in the electric plant at Clay City, Ind. Ralph Cravis was killed, and John Swinger was seriously injured. The plant was wrecked, and the property loss was estimated at \$10,000.

(192.) — On May 22 a blow-off pipe ruptured at the plant of the Bass Foundry & Machine Co., Rock Run, Ala. Abner Dobbs was injured.

(193.) — A boiler exploded, May 23, in J. M. Rush's sawmill, two miles south of Julian, N. C. S. C. Thomas was seriously injured.

(194.) — Several cast-iron headers fractured, May 23, in a water-tube boiler at the gas plant of the Public Service Corporation of New Jersey, St. Paul and Duffield streets, Jersey City, N. J.

(195.) — On May 25 a blow-off pipe ruptured on a boiler at the Little Ferry Paper Co.'s plant, Little Ferry Station, Hackensack, N. J. George Scott was killed, and Charles Rogervitch was injured so badly that he died a few days later.

(196.) — The crown sheet of a boiler gave away, May 25, in the basement of the Baltimore Dairy Lunch, 205 Main street, Rochester, N. Y.

Steam Boiler Explosions in the United States during 1906.

It has been our custom, for many years past, to keep a record, as complete and accurate as possible, of the steam boiler explosions that occur in the United States. Brief accounts of these explosions are printed, as our readers know, in THE LOCOMOTIVE; and at the end of each year, or as soon as practicable thereafter, we publish a summary of the explosions of the year, giving the number of explosions, and the number of persons killed and injured. The statistics thus published are the most complete that can be had, anywhere, concerning steam boiler explosions, and yet we are aware that they are not perfect, as we frequently learn, after the publication of the results for a year, of explosions that were not included in the list. It is impossible, however, to make use, today, of knowledge that does not come to us until tomorrow, or next year; and in publishing our statistics we give the results according to the best information available at the time of publication. The data collected by us from January 1, 1879, to January 1, 1904, are summarized in the issue of THE LOCOMOTIVE for April, 1904, page 45; and the data for the years 1904, 1905, and 1906 are summarized, respectively, in the following issues: October, 1905, page 227; January, 1906, page 19; and January, 1907, page 157.

As the number of boiler explosions is much larger than any person not especially interested in our statistics would realize, we have prepared a map of the United States, upon which the location of each boiler explosion that was recorded by us in the year 1906 is marked by a dot; and this map is reproduced in the present issue. The original drawing, from which this engraving was prepared, is much larger, and therefore much clearer; and it may be seen in the Hartford office of this company.

The number of explosions represented upon the map is 431; and our records show that 235 persons were killed by these explosions, and that 467 other persons were injured. We may roughly say, therefore, that every alternate dot represents the death of one man, and that *every* dot represents the more or less serious injury of another man.

As might be expected, the explosions were grouped in a marked manner about the region in which steam power is most extensively employed. The comparative absence of dots in the western portion of the map is due in large measure to the fact that there are fewer boilers in that part of the country; but there can be no doubt that the reports that we receive from regions west of the Mississippi are less complete than those that come to us from the north-eastern section, so that the relative scarcity of the dots in the west is attributable, in some measure, to the incompleteness of our data.

Furthermore, we should add that the absence of dots from any given region cannot be construed as indicating a greater degree of security in that section, in proportion to the number of boilers there. It must be remembered, too, that a region that was comparatively free from boiler explosions in 1906 may be visited by an undue proportion of them in 1907. A good example of this fact is afforded by Oklahoma and Indian Territory. These, during the entire year 1906, had but one explosion, as will be seen by the map; while during the five months of the present year for which our statistics have been thus far compiled, they have together had five, with a total of three men killed and one injured.

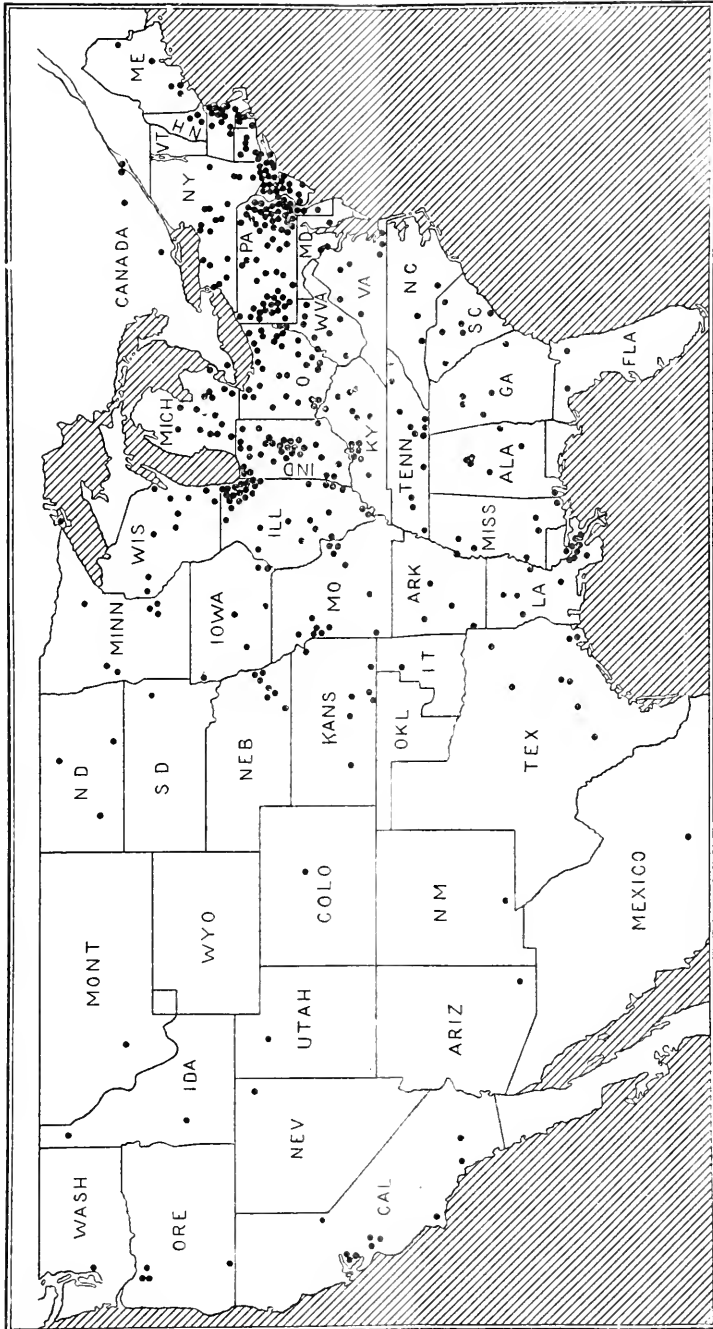

LOCATIONS OF STEAM BOILER EXPLOSIONS IN THE UNITED STATES DURING 1906.

The Locomotive.

A. D. RISTEEN, PH.D., EDITOR.

HARTFORD, JULY 1907.

*THE LOCOMOTIVE can be obtained free by calling at any of the company's agencies.
Subscription price 50 cents per year when mailed from this office.
Bound volumes one dollar each. (Any volume can be supplied.)*

The Hartford Steam Boiler Reinsures the Philadelphia Casualty.

(FROM THE HARTFORD TIMES, July 10, 1907.)

The Hartford Steam Boiler Inspection and Insurance Company has reinsured all the outstanding steam boiler insurance business of the Philadelphia Casualty Company, of Philadelphia, Penn., which had in force upwards of 1,000 steam boiler policies, covering about 2,000 boilers. The estimated amount of insurance was about \$12,000,000, or about \$6,000 per boiler, on the average.

The Philadelphia company was organized and began business in March, 1900, and last year the departments of insurance that it carried were accident, health, liability, plate glass, steam boiler, and credit insurance. The company found that steam boiler insurance is an expensive business to conduct, requiring an expensive mechanical organization for the necessary inspection of the boilers. Lyman B. Brainerd, president of the Hartford Steam Boiler Inspection and Insurance Company, has personally carried on the negotiations with the Philadelphia company for the transfer of the business, and has made several recent trips to Philadelphia in relation to the deal. Reasons for the transfer of the business are made plain in the following copy of a letter issued by the Philadelphia Casualty Company to its policy-holders:

DEAR SIR:—We beg to announce that all of our outstanding steam boiler risks have been transferred to and reinsured in the Hartford Steam Boiler Inspection and Insurance Company, of Hartford, Conn., and since it is not contemplated that the relation of our agents to these risks shall be changed, but that, upon the other hand, the Hartford company will seek to hold and renew these risks through our agents who have produced the business, we feel that our agents, as well as our policy-holders, are to be congratulated upon the consummation of this reinsurance contract with the Hartford,—a company that has resources exceeding \$4,000,000; that has had nearly forty-one years of experience in the business; that makes steam boiler inspection and insurance its only business; and that now controls about three-fourths of the entire steam boiler insurance written upon this continent.

Steam boiler insurance is an expensive business to conduct, under any circumstances. It requires the maintenance of an expensive mechanical organization throughout the entire territory in which the company operates, and the employment of a large force of skilled mechanics, in order to conduct the business with economy, and to provide a prompt and efficient inspection service.

The aggregate of the business to be had is limited, and the fierce competition among the many companies that are dabbling in it forces rates so low that it is exceedingly difficult for any one company to secure a volume of premiums sufficient to sustain the extended and expensive organization required for a dependable inspection service, and for these reasons we have reinsured as above stated, and we are convinced that the reinsurance of our steam boiler business strengthens our position as respects other lines of insurance written by us, because our resources can be used in our other lines to a better and more profitable advantage than is possible in boiler insurance under existing conditions; and we shall accordingly make our policies in other lines of insurance, and the service thereunder, more valuable to our policy-holders than they have ever been.

We thank you for the patronage bestowed upon us, and trust that we shall have an opportunity from time to time to figure with you for business in such lines as we shall continue to write, and we assure you that we will endeavor to merit the confidence reposed in us.

The Hartford company will inspect your boilers during the remainder of the term covered by our policy, and will not disturb your relationship with our agent through whom the insurance was originally placed with us, but will be quite willing to renew the business for and through such agent.

Yours truly,

THE PHILADELPHIA CASUALTY CO.,

R. S. KEELOR, *Secretary.*

An aspect of the steam boiler insurance business can be gained from the following figures: Last year there were twelve companies doing steam boiler insurance business. The total cash premiums paid during the year to the twelve companies operating in the United States were \$2,110,873.56, an average per company of \$175,906.13. Of the total cash premiums, there were paid to the Hartford Steam Boiler Inspection and Insurance Company alone, \$1,340,435.90, leaving \$770,437.66 for the other eleven companies.—an average of \$70,039.78 for each of the eleven remaining companies. The Hartford company is the oldest in the business, and will complete its forty-first year on October 6th.

Obituary.

CARLOS CLINTON KIMBALL.

It is with deep regret that we announce the death of Mr. Carlos Clinton Kimball, who passed away, June 13, 1907, at his home on Farmington avenue, Hartford, Connecticut. Mr. Kimball was born April 24, 1828, at Ellington, Connecticut, and was graduated from the Ellington Academy, and from the Williston Seminary, Easthampton, Massachusetts. The early years of his life were devoted to educational work. He was at one time assistant principal of Ellington Academy, and he held similar positions, also, at Norwich and New Haven. In 1862 he came to Hartford, and from that date he has been engaged continuously in the insurance business. He first became manager for New England (outside of Boston) for the Insurance Company of North America, and has always retained his connection with that company, although various other first-class fire companies were afterwards added to his agency. He was president for three years of the Hartford Life and Annuity Company, and during this period he placed the company on a dividend-paying basis, restoring its capital from an impaired condition. He was made president of the Smyth Manufacturing Company in 1884, and held that position at the time of his death. He was also a director

in numerous other Hartford institutions, for his business judgment was excellent, and his counsel was accordingly sought on every hand. Mr. Kimball became a director of the Hartford Steam Boiler Inspection and Insurance Company on February 17, 1891, and a member of its finance committee two years later. He was upright in character, courteous in manner, positive in his convictions, and of wide experience; and in his death this company loses one of its oldest and most valued counsellors.

MR. GEORGE C. KIMBALL, vice-president and treasurer of the Smyth Manufacturing Company, was elected a director of the Hartford Steam Boiler Inspection and Insurance Company, on June 27, to fill the vacancy created by the death of his father, Mr. C. C. Kimball.

Dr. Julius Robert Mayer.

The modern theory of the nature of heat is the outcome of the labors of many men, among whom Joule and Mayer deserve especial mention. James Prescott Joule was an Englishman, and the story of his life and labors can readily be found by the student of scientific history who desires to learn of the part that he played in the development of the mechanical theory of heat. (See, for example, the very full and excellent biography in *Lee's Dictionary of National Biography*). Similar information regarding Julius Robert Mayer is not available, so far as we are aware, in the English language; and for this reason we have thought that a biographical notice of him might be of interest. The sketch of his life that is given in the *Encyclopædia Britannica* is grossly unfair to Mayer, and the judgment of him that is there pronounced does not accord with the judgment that has been rendered by impartial critics. The *Britannica* article bears unmistakable evidence, we think, of having been written by Professor P. G. Tait, or at least of having been inspired by him.

Dr. Julius Robert Mayer was born, November 25, 1814, at Heilbronn, Germany, and was the third son of an apothecary of that city. As a boy he showed a taste for mechanical matters, and when about ten years of age he attempted to construct a perpetual motion machine. The impossibility of accomplishing this purpose made a lasting impression upon him, and doubtless influenced his later habits of thought very considerably. He was not among the best scholars in the high school of his native place, for his mind was an original one, and he preferred to reach conclusions by his own methods, rather than to follow the paths laid down by others.

On May 23, 1829, at the age of fourteen, Mayer left the Heilbronn High School, and went to the cloister at Schönthal to continue his studies. Here he stood no better than at Heilbronn; but after a severe entrance examination he entered the University of Tübingen, in the spring of 1832, as a student of medicine. When he left home for the university, his father, apparently as a parting counsel, wrote in the boy's album a German couplet which may be rendered thus:

“Be thou master of thine own self,
And thou shalt then live free and independent everywhere.”

Mayer appears to have prized this advice most highly, for at the time of his death, forty-six years later, the album leaf bearing the couplet hung, framed, over his writing table.

From Tübingen Mayer went to Munich and Vienna, where he attended clinics, returning to Tübingen in January, 1838, to take his degree. His dissertation treated of the medicinal properties of *santonin*, which, although discovered some years previously, was not available in quantity until 1833. After taking his degree, Mayer spent some time in Paris; and while there he secured an appointment as ship physician on the Dutch three-masted sailing vessel *Java*, bound for Batavia. He boarded the vessel at Rotterdam on February 22, 1840, sailing shortly afterwards. The journey to Java lasted 101 days, for 67 consecutive days of which period no land was sighted. During the trip one of the crew told him of the belief among sailors that the sea is warmer when violently agitated by a storm, than it is when calm, and he did not forget this saying, although there is no evidence that it especially impressed him at the time.

The ship reached Batavia about the middle of June, 1840, and shortly after her arrival an acute affection of the lungs broke out among the crew. Mayer considered that copious bleeding was called for, and in letting the blood from the veins of the sailors' arms he observed that it showed a strikingly bright red color, much like that of arterial blood. The German physicians of Batavia assured him that this was a known and recognized phenomenon, observed among natives and foreigners alike. Turning this matter over in his mind, and reflecting that the loss of the red color as the blood passes through the capillaries is due to the abstraction of oxygen from it, and that in the tropics a lesser generation of heat would suffice to maintain the bodily temperature than would be required in colder regions, he concluded that in tropical countries there is a less active oxidation of the tissues of the body, and that the red color of the venous blood that he had observed was the visible sign of this lessened oxidation. Following out the line of thought thus started, he appears, while residing at Surabaya, Java, to have evolved his central idea that heat and mechanical energy are only two different forms of the same thing; or at least that the two are convertible, the one into the other in a perfectly definite manner.

On September 27, 1840, the return voyage of his ship began. It lasted 121 days, and upon his arrival in the Netherlands in February, 1841, he proceeded at once to his native city of Heilbronn, where he made his residence for the rest of his life, save for occasional short intervals. Applying himself diligently to the development of his theory concerning heat, he prepared a paper giving the general principles at which he had arrived, and this paper he sent, on June 16, 1841, to Poggendorff's *Annalen der Physik*, which was then, as its successor is today, the leading physical journal of Germany, and perhaps of the world. He requested Poggendorff to publish the paper if he deemed it suitable for his pages, and to return it if he did not deem it so. No reply was received, although Mayer wrote twice, subsequently, requesting its return; and the fact that Poggendorff really received the manuscript was first definitely established thirty-six years later, when, in 1877, Zöllner recovered it from Poggendorff's heirs.

In 1841 Mayer went to Tübingen, where he consulted with Doctor Nörremberg, professor of physics, as to his discovery. Nörremberg told him that he had done nothing save to take a new view of things that could be equally well regarded from another standpoint, and counselled him to make some crucial

experiment, that should subject the new theory to a decisive test, suggesting that if Mayer's ideas were correct, a fluid like water should become warmed by shaking. Mayer, recalling what the sailor had told him about the sea being warmed by a storm, tried the suggested experiment after his return to Heilbronn, and found that water can be measurably warmed by agitation. Later in 1841 Mayer also visited Jolly, professor of physics in the University of Heidelberg, and consulted with him as to the new theory. Mayer's object in visiting Tübingen and Heidelberg is explained in a letter that he wrote on August 6, 1842, to his friend Baur, in which he says that as he knew that he was himself no physicist, he desired to consult with men having a wider knowledge in this province, in order that he might learn whether the thing that he believed to be new really was so or not, and also to ascertain whether such men would consider the views that he held to be untenable, or probably unfruitful.

The clearness with which the fundamental fact of the equivalence of heat and mechanical energy had fixed itself in his mind, even at this early date, is shown by a letter that he wrote to Professor Baur on September 12, 1841, where he says: "A vital point in connection with my theories (which are capable of development with the rigid certainty of mathematics) consists in the solution of the question: How high must a weight—say 100 pounds—be raised above the earth, in order that the quantity of motion which corresponds to this elevation, and which can be realized by the fall of the weight, shall be equal to the quantity of heat that is required in order to convert a pound of ice at 0° C. into a pound of water at 0° C." Surely it would be hard, even at the present day, to state the case much more clearly than this.

Mayer sought diligently for experimental data which would enable him to solve the problem here suggested; and in the course of his search he found an almost forgotten memoir by the great French physicist, Gay-Lussac, in which it was proved, experimentally and fully, that when air expands into a vacuous space, its temperature is not materially altered. The present article being essentially of a biographical nature, we do not wish to enter unnecessarily upon the discussion of the principles of the theory of heat; but in order that certain developments in Mayer's history may be properly understood, it is necessary that we should at least say that Gay-Lussac's experiment showed that when air is heated by compression, all (or practically all) of the mechanical work that is performed upon it must appear in the form of sensible heat, measurable by the thermometer. That Mayer really was in possession of this experimental evidence as early as 1841 is shown by his correspondence, as since published by Weyrauch ("Kleinere Schriften und Briefe von Robert Mayer," Stuttgart, 1892). The bearing of these remarks will appear subsequently. We may add, however, that Gay-Lussac's original memoir was published in the *Mémoires de Physique et de Chimie* de la Société d'Arcueil, Vol. 1, 1807, page 180. A German translation of this memoir is given in Gehler's *Journal für Chemie, Physik und Mineralogie*, Vol. 6, 1808, page 392. As these periodicals are not commonly accessible at the present day, Mach has done the student of scientific history a real service by reprinting the original French memoir in an appendix to his *Principien der Wärmelehre*.

In the early part of 1842, Mayer, unable to regain his paper from Poggen-dorff, wrote a short essay (in order to protect himself "against eventualities," as he afterwards phrased it), in which he outlined the general nature of his

theory. This paper, which was entitled "Remarks upon the Forces of Inanimate Nature" ("Bemerkungen über die Kräfte der unbelebten Natur"), was published in May, 1842, in Liebig's *Annalen der Chemie und Pharmacie*, and an English translation of it will be found in the *Philosophical Magazine* for November, 1862, page 371. It is manifestly only a preliminary communication, and to be fair to Mayer it should be considered in connection with the more extended memoirs that he published afterward. The language is scholastic in many places, and the mode of presentation is not that of an accomplished modern physicist. Yet he indisputably had the correct idea, and this idea he continued to elaborate in his subsequent papers with wonderful insight. In this first paper he says, with extraordinary sagacity, "Our locomotives, with their trains, may be compared to a distilling apparatus; the heat that is developed under the boiler is transformed into motion, and this is again deposited as heat at the axles of the wheels." This comparison is very clear and illuminating, and would do credit to the best writer of today. Towards the end of the paper, Mayer gives an actual numerical determination of the mechanical equivalent of heat, and he says: "The fact that such an equivalent actually exists in nature can be taken as a résumé of the reasoning that has been presented up to this point." The calculation is not given in full, but the method that was followed is indicated sufficiently, so that there has never been any question about its nature. He compared the mechanical work done in compressing atmospheric air with the heat that is developed by the compression, and determined the mechanical equivalent by regarding the two as equal to each other, as Gay-Lussac's experiments had shown them to be. It is most unfortunate that Mayer did not explicitly refer to Gay-Lussac's memoir in his own first paper; for the English writers, with the exception of Tyndall and perhaps a few others of lesser prominence, unaware at first of its existence, persisted, even after their attention had been called to it, in ignoring its bearing upon Mayer's calculation. Mayer, in fact, was treated as though he were dishonest, and had discovered the existence of Gay-Lussac's memoir *after* his own had been written; and the fact experimentally established by Gay-Lussac was persistently referred to as "Mayer's hypothesis," and treated as though it were merely the result of a very fortunate guess, which, on that account, could have no scientific standing.

The numerical result obtained by Mayer was that "to the fall of a given weight from a height of about 365 meters, corresponds the warming of an equal weight of water from 0° to 1° C." In English measure this height would be 665 feet per Fahrenheit degree, instead of 772 feet, as given later by Joule. It has since been shown, however, that with a value of the specific heat of air (at constant pressure) more accurate than was then available, Mayer, by identically the same process, would have obtained 771 as the mechanical equivalent (in English measure), which would be in striking accord with Joule.

Upon his return from the East Indies in 1841, Mayer was made chief surgeon to the bailiwick of Heilbronn, and a few years later he became city physician. He was married in August, 1842, at the age of twenty-seven. After the appearance of his first paper, Mayer continued to follow out the consequences of his theory, and by the end of 1844 he had completed a much more elaborate memoir, in which he applied his views to the animal machine. The title of this second memoir was "Organic Motion in Its Connection with Transformations of Matter" ("Die organische Bewegung in ihrem Zusammenhang mit dem Stoff-

wechsel"). This was first sent, on January 3, 1845, to Liebig's *Annalen der Chemie und Pharmacie*, in which his first paper was published; but the manuscript was returned to him with thanks, accompanied by a letter of date January 6, 1845, from Liebig's assistant, stating that the journal had on hand such a press of chemical matter awaiting publication that Mayer's memoir could not be used. Mayer then had it printed at his own expense by C. Drechsler, of Heilbronn, and it appeared about the middle of the year 1845. It may be remarked in passing that the early writings of other well-known men upon the new theory of heat were received in much the same manner as Mayer's. Thus the first papers of Mohr and Helmholtz were also declined by Poggendorff; and Faraday, after examining Joule's first paper (of 1843), advised him not to present it to the Royal Society, though this advice was fortunately not followed.

In 1846 Mayer sent to the Paris Academy of Sciences two communications concerning the origin of the sun's light and heat. These were referred to committees, but were never printed in the *Comptes rendus*. Mayer next tried to have his studies on the sun's heat published in pamphlet form by the J. G. Cotta publishing house, at Stuttgart; but his manuscript was again declined. He finally succeeded in getting a third paper, entitled "Contributions to the Dynamics of the Heavens" ("Beiträge zur Dynamik des Himmels"), published by Johann Ulrich Landherr, a Heilbronn publisher, in 1848. In a lecture on "Force," delivered before the Royal Institution on June 6, 1862, and printed in the *Philosophical Magazine* for July, 1862, page 57, Tyndall says: "In 1842 Mayer had actually calculated the mechanical equivalent of heat from data which a man of rare originality alone could turn to account. . . . In 1845 he published his memoir on 'Organic Motion,' and applied the mechanical theory of heat in the most fearless and precise manner to vital processes. . . . In 1853 Mr. Waterston proposed, independently, the meteoric theory of the sun's heat; and in 1854 Prof. William Thomson [Lord Kelvin] applied his admirable mathematical powers to the development of the theory; but six years previously the subject had been handled in a masterly manner by Mayer." This tribute will give some idea of the scope and generality of Mayer's papers, but the papers themselves must be read to be properly appreciated.

James Prescott Joule's first paper dealing with the mechanical theory of heat was read before the British Association at Cork, on August 21, 1843, fifteen months after Mayer's first paper was published, and Joule tells of its reception thus: "The subject did not excite much general attention; so that when I brought it forward again at the meeting in 1847, the chairman suggested that, as the business of the section pressed, I should not read my paper, but confine myself to a short verbal description of my experiments." See Joule, *Scientific Papers*, Vol. 2, page 215.) Joule published in the *Comptes rendus* (August 23, 1847) a short paper stating that for the previous four years he had been making experiments for the purpose of assuring himself that "heat is equivalent to mechanical force,"—or, as we should now say, that heat is a form of energy. In the same journal for 1848, Vol. 27, page 385, there appears a brief statement by Mayer, in which Mayer reviews what he has himself published. Thus the question of priority between Joule and Mayer was raised, apparently for the first time. We find a reply by Joule in the *Comptes rendus* for 1849, Vol. 28, page 132; and here, so far as the present writer is aware, the question of the justifiability of Mayer's method of calculating the mechanical equivalent is

first raised, Joule intimating that Mayer had begged the question, as at the time he wrote his paper there were no known facts that would justify the method. Mayer replied (*Comptes rendus*, 1849, Vol. 29, page 534) stating that he had *not* made the assumption with which he was credited, and pointing out that (contrary to Joule's assertion) the matter in question had been fully treated by Gay-Lussac in 1807; and here Mayer for the first time, in his published writings, gave the exact reference to Gay-Lussac's original memoir, although he had mentioned it in his paper of 1845. Joule made no further reply until fourteen years later, when he printed a letter in the *Philosophical Magazine* (August, 1863, page 145), stating that he had not yet looked up the memoir by Gay-Lussac, and adding that "it may be gathered from M. Mayer's papers that he knew nothing of this experiment of Gay-Lussac when he wrote his celebrated memoir of 1842." The words here quoted are highly discreditable to Joule, but they fairly reflect the discourteous attitude that Professor Tait and certain of his followers chose to adopt towards Mayer.

Mayer was greatly affected by this dispute, mild as it was. On August 19, 1848, his daughter Anna died, and six days later his little daughter Julie followed. It may be imagined, therefore, that he was in no happy frame of mind when he penned his first reply to Joule, which was presented to the French Academy at the session of October 16, 1848.

On May 14, 1849, Mayer published a short article in the *Allgemeine Zeitung*, a journal published in Augsburg and widely read among educated persons; and in reply to this there was printed in the same journal an article by a young physicist, Dr. Otto Seyffer, in which Mayer's first paper was declared to be a medley of baseless views concerning the forces of nature, and his deductions were said to have been shown, in the scientific periodicals, to be untenable. Seyffer also said that Mayer's theory that there can be an actual transformation between heat and work is a completely unscientific proposition, contradicting every clear view concerning the constitution of nature. Less than a year later (namely, on April 18, 1850), Seyffer said elsewhere, "I acknowledge the discovery of the so-called equivalent number between mechanical energy and heat to be an established fact." Mayer hoped that in view of this retraction, the *Allgemeine Zeitung* would set him right before its readers; but nothing of the kind was done.

The way in which his labors had been received by the world weighed upon Mayer's spirit so heavily that his mental powers began to fail. Early on the morning of May 28, 1850, after a hot and sleepless night, he suddenly passed into a delirious state, and threw himself, before the eyes of his wife and while still undressed, from the window of his sleeping room into the street, thirty feet below. He was severely injured in consequence, and passed many weeks upon a sick-bed. Some months later he was able to go about by the aid of a staff, and attend to his practice; but for a year he moved slowly and painfully, having to draw his right leg after him as he walked; and he never entirely recovered. His father, to whom he was greatly attached, died in September, 1850; but in December of the same year we find Mayer, with his theories ever foremost in his mind, writing the preface to a paper entitled "Remarks Concerning the Mechanical Equivalent of Heat" ("Bemerkungen über das mechanische Aequivalent der Wärme"), which was published by Landherr at Heilbronn in 1851, and which constituted the last of Mayer's great papers upon the mechanical

theory of heat, although other papers of his appeared up to the year 1876.

The violent delirium which caused Mayer to throw himself into the street in 1850 was the forerunner of a period of mental aberration which presently fixed itself upon him, and incapacitated him for a considerable period. His lack of mental balance manifested itself in various ways, and fits of aberration came upon him at almost regular intervals, until, on the night of July 31, 1852, he was placed in a strait-jacket, and on the following morning was removed to Winnenthal for confinement and treatment. The treatment that he received, however, appears to have been unintelligent. It shadowed his entire subsequent life, and he has described it as unscientific and barbarous. He was liberated from Winnenthal in September, 1853, and returned to Heilbronn.

In the latter years of his life Mayer was honored by learned societies and institutions, but he was then broken both in body and in spirit, although his natural cheerfulness showed itself even upon his deathbed. In 1877 a small swelling appeared upon his right arm, and as a similar symptom had been the forerunner of his mother's death, his wife questioned him about it anxiously. He answered that the swelling itself was of no importance, but that it was a sign of some internal trouble. He then told her that his lungs were affected, and that the swelling on his arm was a consequence. About Christmas, 1877, Mayer became seriously ill, the condition of his lungs growing worse, with hemorrhage and an increasing fever; and he died on March 20, 1878. His last moments were peaceful, and his daughter states that in his last illness he was cheerful and happy.*

Marks on Boiler Tubes.

(From INSURANCE ENGINEERING, June, 1907.)

To those interested in boiler hazards, something may be said relative to boiler tubes and the disadvantages of the present unsatisfactory method of marking them with white lead stenciling, which is easily rubbed off, instead of stamping them indelibly, according to their quality, at the place of manufacture, as is done in the case of boiler plate. This matter, in the writer's judgment, is one of the most important details that could engage the attention of "Insurance Engineering," not only because the subject is one of commercial interest, but also for humane reasons, since the proposed change would provide some additional safeguard for the protection of life and limb. The indelible stamping that is suggested above would promote the adoption of higher standards of material and of workmanship in boiler tubes, and this would be of special importance in the case of water-tube boilers, where tubes of the best possible quality are necessary in order to meet the requirements for safety and durability under the increased exposure and higher steam pressure.

The demand is for higher steam pressures on boilers; and yet, even when the purchaser is quite willing to pay for the best quality and the safest boiler tubes, there is no sufficient guarantee (such as would be afforded by a mill stamp) that in demanding a superior tube, he gets what he pays for. If the manufacturers of tubes and steam pipes would stamp their product legibly, and in the way that boiler plate manufacturers stamp theirs,—say, at the

*In the preparation of this article, many sources of information have been consulted; but we desire to give special credit to Weyrauch's "Mechanik der Wärme, in gesammelten Schriften von Robert Mayer", third edition, Stuttgart, 1893.

ends and in the middle of each section of tube or pipe,—the safeguarding of their own interests would be an incentive, on account of the commercial advantage involved, to produce the best tubes or pipes possible, thus protecting the purchaser who desires to pay for the best.

In building high-pressure boilers, the plates of which are tested and certified to, by the manufacturer, as of the best quality and workmanship obtainable, why should we be forced to use steel boiler tubes, or steel piping and fittings, of unstamped and perhaps unknown quality, when all the parts are to be subjected to the same high pressure? Yet is this not the course that is actually pursued every day?

To remedy this state of things, let us favor standard parts of stamped material, as the best way to secure the best materials and the best workmanship, since the use of plain stamps would afford an unequivocal means of identification, and would also aid in the selection of goods of the best quality. Such stamps would also be of the greatest value in cases of failure, where investigation might show that the best material was selected. If, under the practical conditions of test, the article (tube or fitting) was not found to be up to the trade representations made at the time of its purchase, an inspection of the stamps would be of the greatest service in fixing the responsibility for the failure, and in determining who was at fault. This is very difficult, if not impossible, under the present conditions of unstamped work.—FRANCIS B. ALLEN, *Vice-President*, Hartford Steam Boiler Inspection and Insurance Company.

The Properties of Steam.

FOURTH PAPER.—EXPERIMENTS AT THE HIGHEST TEMPERATURES AND PRESSURES.

In the three papers that we have previously published, concerning the properties of steam, we have described experimental researches relating mainly to pressures that may occur in actual steam engineering practice. This classification is not to be taken too literally, for it will be remembered that Ramsay and Young carried their investigations up to a pressure of nearly 55 atmospheres; but it is a convenient one for some purposes, and it is evident that any classification that might be given would still be more or less arbitrary and inexact. In the present paper we shall describe the experiments that have been made at pressures running up as high as 200 atmospheres; this being approximately the limit at which there ceases to be a definite relation between the pressure and temperature of steam. In fact, at temperatures exceeding that which corresponds to this limiting pressure, it is impossible for water to exist in the liquid state, and hence it is also impossible for saturated steam to exist.

Regnault's researches, which were described in our first paper (*THE LOCOMOTIVE*, July, 1906, page 85), were carried up to a pressure of about 28 atmospheres. At this pressure the boiler that he used was strained so severely that it had taken a visible permanent set, and he did not deem it prudent to attempt to carry the pressure even up to 30 atmospheres, which was the maximum pressure that his mercury gage would measure. (Regnault, *Relation des Expériences*, Vol. 1, page 552.)

Regnault (*l.c.*) was of the opinion that it would be quite possible to carry the experiments to a much higher pressure than he attained, by means of an

apparatus closely like the one that he actually employed for his highest pressures; but he says that the expense of making the apparatus deterred him from the attempt. Subsequent experimenters, in dealing with heavier pressures, have found it advisable, however, to use apparatus of an entirely different character, in which the steam under investigation is confined in a receptacle of small diameter. (See, for example, our second and third papers, in the present series.) For the very highest pressures (and temperatures), it is necessary, not only to confine the steam within a receptacle of small diameter, but also to construct this receptacle of some substance other than glass, since (as previously noted) glass is notably soluble in water at very high temperatures.

We are indebted, for our knowledge of the properties of steam at the highest pressures and temperatures, mainly to Battelli, and to Cailletet and Colardeau; though there is a confirmatory series of measurements by Knipp, to which reference will be made, below.

Battelli's researches at high temperatures and pressures are given in full only in his original paper in the *Memorie della Reale Accademia delle Scienze di Torino* (*Memoirs of the Royal Academy of Sciences of Turin*), Vol. 41, 1891, page 25; but an abridged translation into French will be found in the *Annales de Chimie et de Physique*, Series 6, Vol. 26, 1893, page 410. The French translation is not so complete as could be desired, in some particulars, notably in respect to the thermometry of the research; and, moreover, it contains several errors. The immediate purpose of the research under discussion was to determine the critical temperature, pressure and volume of water; and while the observations are all given in the original Italian (though *not* in the French translation), the saturation pressures deducible from them are not definitely stated in either of the papers to which reference is made above, except in connection with the critical point. We shall therefore depend, for the general description of the apparatus, upon the 41st volume of the *Memorie*, already cited; while for the final numerical values of the saturation pressures that were observed at the various temperatures, we shall be obliged to refer to his later memoir in the 43d volume of the *Memorie*, which was reviewed in our second paper (*THE LOCOMOTIVE*, October, 1906, page 116), and in which Battelli gives, for the first time, the numerical values of these saturation pressures, as obtained from the experiments described in the 41st volume.

The apparatus used by Battelli is shown in Figs. 1 and 2; Fig. 1 giving the details of the part containing the water under investigation, while Fig. 2 is a reduced sketch of the entire apparatus, from which the general relations of its parts can be seen. By way of extenuation for any inaccuracy that there may be in our illustrations, it should be explained that the original illustrations from which they were prepared are not entirely clear in all respects, and are certainly not drawn to scale. We have followed the original illustrations in a general way, but have endeavored to show the parts in correct proportion, whenever the text gave the necessary dimensions. In some few details we have departed from the originals, too, where the parts as shown in Battelli's diagrams either did not conform with the description in the text, or where they appeared improbable, by reason of being unmechanical. It is believed, however, that the engravings that are here given represent the original apparatus with fidelity in all essential respects.

The water that was used was purified with all the care possible, by the

elaborate method described in our second paper, page 119. The experimental tube, in which the water under experiment was confined, was made of steel, and is shown at *T* in Fig. 1. It was 8 millimeters (0.31 in.) in diameter, internally, 4 millimeters (0.16 in.) thick, and 300 millimeters (11.8 in.) long. This tube was placed in a vertical position, and its lower portion was filled with pure mercury; the water being introduced into the upper part of the tube with elaborate care, so as to ensure the absence of any trace of air. The experimental tube was threaded at its lower end, and was screwed into a similarly threaded hole drilled in the bottom of a cast-iron flask, *A* in Fig. 1, such as is used, in commerce, for the shipment of mercury. The iron flask, *A*, was itself partially filled with mercury, as shown at *M*, and was surrounded externally by two gas burners, one at the bottom of the flask, and the other near its middle. By means of these gas burners the mercury, *M*, could be made to boil, and the contents of the experimental tube, *T*, be thereby maintained at a constant temperature. The upper part of the iron flask was closed by an iron stopper, *B*, which was provided with a spring safety-valve, as indicated; the tension of the spring being capable of regulation by means of the screw shown at *E*. When the apparatus was in operation, the mercury, *M*, was brought to full ebullition, so that mercurial vapor was constantly escaping through the safety-valve in the plug, or stopper, *B*, into the space within the cylinder *D*, where it was condensed again by means of a condenser, *C*, through which a stream of cold water was continually flowing. At the ordinary pressure of the atmosphere, pure mercury boils at about 357.2° C.; but by compressing the spring of the safety-valve by turning the screw *E*, Battelli could cause the mercury, *M*, to boil under a pressure higher than that of the atmosphere, and therefore at a temperature greater than 357.2° C. In this way he obtained temperatures, within the flask *A*, ranging from 358.7° C. to 375.15° C. By substituting, for the mercury, two different mineral oils, or paraffins, he also realized the temperatures 311.2° C. and 333.6° C.

In Fig. 2, *F* is a steel tube of small diameter, filled with mercury, and serving to connect the experimental tube, within the flask *A*, with the pressure-gage, *G*, *H*. The tubes *G* and *H* were of glass, about one-tenth of an

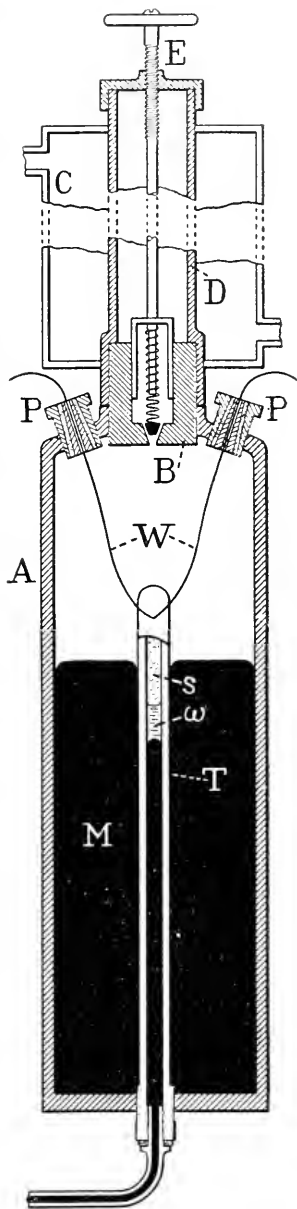

FIG. 1.—SHOWING CERTAIN DETAILS OF BATELLI'S APPARATUS.

inch in internal diameter, and about one-fifth of an inch thick. These tubes were carefully graduated and calibrated, and were united at the top by an iron tube, *J*, of known capacity. The tube *H* was secured at its lower end to a hollow cast-iron sphere, *U*, which was, in its turn, in communication with two bronze spheres, *N N*, containing ether. By heating the ether within the spheres *N N*, by means of a gas flame, a high pressure could easily be generated within the spheres, and this pressure was communicated, by means of mercury, to the air in the tubes, *H* and *G*, and through this air to the mercury in the tube *F*, and so, ultimately, to the contents of the experimental tube within the flask *A*.

The magnitude of the pressure so produced was determined by observing the amount of compression experienced by the air within the gage-tubes, *G H*,

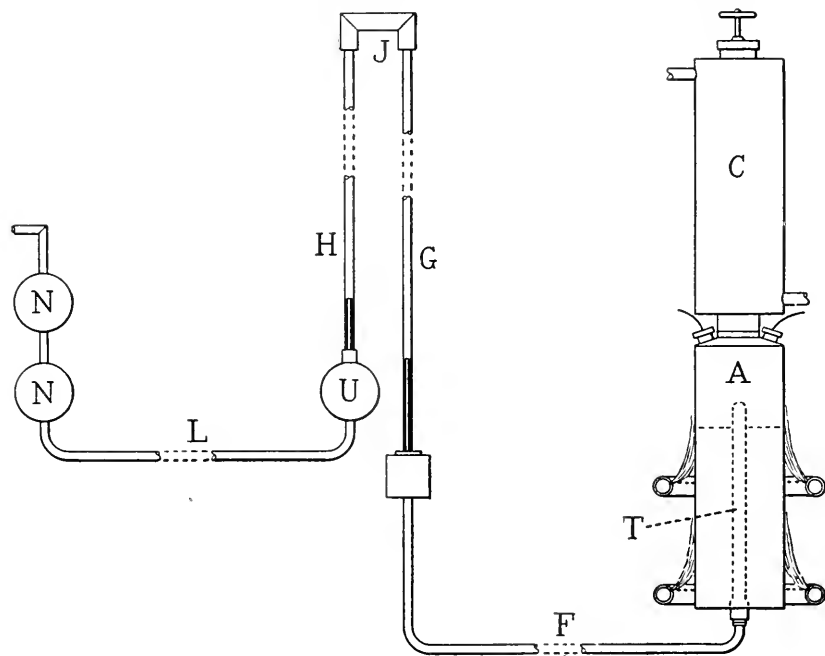

FIG. 2.—GENERAL ARRANGEMENT OF BATTELLI'S APPARATUS.

which were kept at the constant temperature 16° C., by means of glass jackets (not shown), containing water. (The general principle of the compressed-air pressure gage was explained in the third paper of this series, and hence it need not be repeated here. The data for correcting the readings of the gage for the inaccuracy of Boyle's law, for the higher pressures dealt with by Battelli in this memoir, are given by Amagat in the *Annales de Chimie et de Physique*, Series 5, Vol. 19, 1880, page 345.)

Battelli attempted to determine the temperature of the space surrounding the experimental tube *T*, in Fig. 1, by means of an air thermometer, whose bulb was situated within the flask, *A*. If we understand his language correctly, he did actually perform some of the experiments, at the lower pressures, in this manner; but he says that he found that as soon as the pressure within the flask

A became one atmosphere or so, it became impossible to keep the joint tight, where the stem of the air thermometer left the flask *A*. He was therefore impelled to make use of a thermoelectric couple for determining the temperature, in the greater part of the work. This couple consisted of an iron wire and a nickel wire, shown at *II'* in Fig. 1. These entered the flask *A* through two plugs, *P P*, which were ingeniously constructed, so as to combine strength and tightness with good insulation of the wires. The junction between the two wires rested against the experimental tube, save that a small pad of asbestos was interposed, for the sake of insulation. It might be thought that the mercury vapor in the flask *A* would affect the wires so as to impair the accuracy of the temperature-determinations; but Battelli assured himself that this was not the case. He also bore in mind the anomalous thermoelectric behavior of nickel, and considered that this did not influence his results prejudicially. The junction of the iron-nickel couple that rested against the experimental tube was the "cold" junction; the "hot" one being exposed continuously, throughout the experiments, to the vapor of boiling sulphur (about 446° C.). By way of checking his thermometry, Battelli measured the boiling points of several samples of mercury, of varying degrees of purity, both with his thermoelectric couple, and with the air thermometer; the maximum difference observed being 0.2° C.

Battelli carefully determined the volumes of the tubes *T* and *F*, and the volume of the gage tube *G*, up to each of its graduation marks. He also accurately measured the quantity of water introduced into the experimental tube, and the quantity of mercury included in the tubes *G*, *F*, and *T*. When the apparatus was cold and subject to no pressure, and the water in the top of the experimental tube was all in the liquid form, the height of the mercury in *G* was observed and recorded. Any increase in the volume of the water in the experimental tube would then cause the mercury in *G* to rise by a corresponding amount; and Battelli could therefore, at any stage of the work, determine the total actual volume occupied by the water (and steam) in the experimental tube, by noting the position of the mercury in the tube *G*. Of course it would be necessary to introduce corrections for the expansion of the mercury and the steel tubing under the influence of heat, and for the compressibility of mercury and the dilatation of the tubing under the influence of pressure. Battelli attended to all these matters, and in his original Italian memoir, he gives full information concerning the determination of these corrections.

Let us now consider the way in which the apparatus was used, in carrying out the experimental work. Evidently the water in the upper part of the experimental tube, *T* in Fig. 1, might exist there entirely in the form of liquid, or entirely in the form of vapor, or partly in one form and partly in the other; the latter case being suggested, in Fig. 1, at *s* and *τ*. In the apparatus used by Ramsay and Young, and in that used by Battelli himself at lower pressures, the experimental tube was made of glass, and the physical state of its contents could be observed by the eye, directly. In the apparatus here described, however, the experimental tube and the flask surrounding it were opaque, so that the physical state of the water within the tube had to be inferred by an indirect method.

Let us suppose the mercury, *M* in Fig. 1, to be kept boiling at a constant pressure, so that the tube *T* is thereby kept at a constant temperature, which is known by means of the thermoelectric couple, *II'*. The pressure within the experimental tube is then known by observing the volume of the air in the gage

tubes, *G H* in Fig. 2; and the volume occupied by the water and vapor in the experimental tube is known by observing the level of the mercury in the tube *G*. Keeping the experimental tube still at the same temperature, suppose an attempt is made to raise the pressure in this tube, by heating the bulbs *N N* more strongly. If the water in the tube *T* is all in the liquid form, it will be practically incompressible, and raising the temperature of the pressure-bulbs *N N* will therefore cause an immediate and very considerable rise in pressure, which will be indicated at once, and very plainly, by the pressure gage, *G H*; and this increase of pressure will take place without any material change in the level of the mercury in *G*. On the other hand, if the water in the experimental tube *T* is all in the state of superheated vapor, then an attempt to increase the pressure in the apparatus by raising the temperature of the pressure bulbs *N N* will result in an increase of pressure which will be readily observed, but which will be less in magnitude than before, and will be accompanied by a visible depression of the mercury level in *G*. Finally, if the water in the experimental tube is partly liquid and partly in the form of saturated vapor, an increase in the temperature of the pressure bulbs, *N N*, will merely cause some of the vapor in *T* to condense, and the level of the mercury in *G* will fall, without any sensible increase of pressure as indicated by the gage *H G*. In other words, the mercury in *G* will fall, while that in *H* will rise by an equivalent amount. It will be seen, therefore, that the behavior of the apparatus, during the experimental work, will show, at every moment, the physical condition of the water in the experimental tube; and when the tube *T* is kept at a known constant temperature, the pressure at which the water can exist partly as liquid and partly as vapor is the pressure of saturated steam corresponding to the known temperature of *T*.

In this way Battelli obtained an extensive series of experimental data, from which he deduced the results given in Table 1, respecting the pressure of saturated steam at the six given temperatures. These temperatures, it will be observed, are supposed to be on the scale of the air thermometer (though he does not say what kind of an air thermometer); for although they were measured, for the most part, by the thermoelectric couple, yet this couple had been itself compared with the air thermometer, so that its readings are on the air scale.

TABLE 1.—BATTELLI'S EXPERIMENTAL RESULTS RESPECTING THE PRESSURE OF SATURATED STEAM AT HIGH PRESSURES.

Temperature. (Centigrade.)	Pressure in Millimeters of Mercury.	Temperature. (Centigrade.)	Pressure in Millimeters of Mercury.
311.2°	79504.	361.9°	143471.
333.6	105015.	363.1	146688.
358.7	139116.	364.3	147900.

For the critical temperature of water, or the temperature beyond which there is no distinguishable difference between liquid water and steam (see THE LOCOMOTIVE for November, 1891, page 173), Battelli found 364.3° C.; the corresponding pressure being 147,900 millimeters of mercury (or 194.61 atmospheres), and the critical volume, or volume of one gramme of water (or

steam) at the critical temperature and pressure, 4.812 cubic centimeters. From a study of the graphical process by which Battelli reached these numerical results, it appears to the writer that Battelli's own method and observations indicate a critical temperature about one or two tenths of a degree lower than 364.3° . The difference is so trifling, however, that Battelli's estimate has been retained.

The experimental data obtained by Cailletet and Colardeau, with respect to the pressure and temperature of saturated steam at high pressures, will be found in a paper entitled "Nouvelle Méthode de Détermination du Point

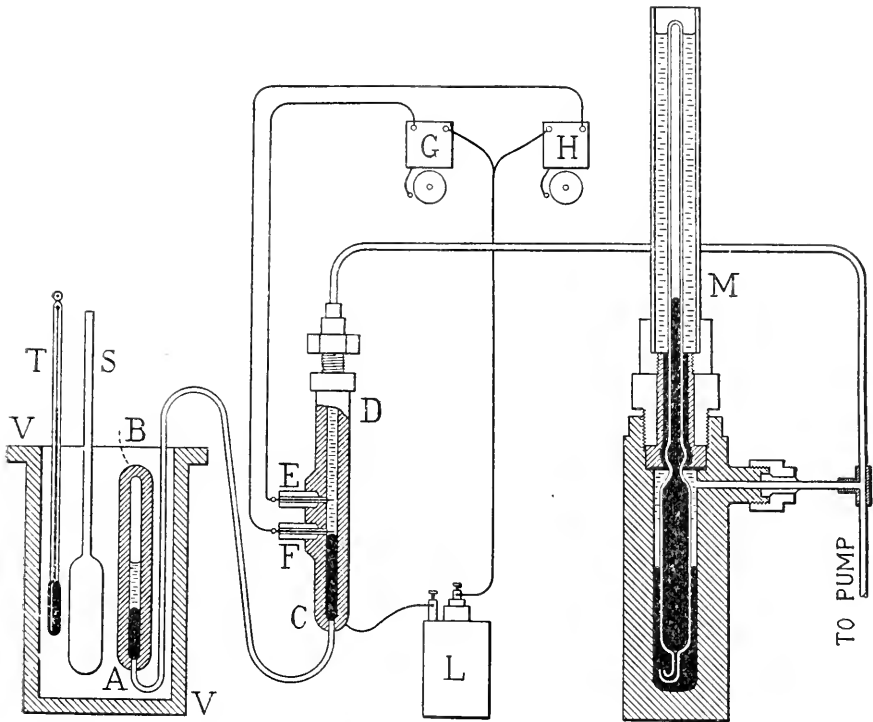

FIG. 3. — APPARATUS OF CAILLETET AND COLARDEAU.

Critique" ("New Method for the Determination of the Critical Point"), in the *Annales de Chimie et de Physique*, 6th Series, Vol. 25, 1892, page 519. A good, though brief, account of their work is also given in Preston's *Theory of Heat*, page 383.

The apparatus used by these experimenters is shown in Fig. 3. The water whose properties were to be investigated was enclosed in a steel tube or bulb, *A B*, which communicated with a similar and equal bulb, *C D*, by means of a thin, flexible steel tube filled with mercury. The upper part of the bulb *C D* communicated, by means of a second flexible steel tube containing water, with a pressure gage or manometer, *M*, in which the pressures were measured by noting the degree of compression experienced by a fixed quantity of hydrogen gas, enclosed in a glass tube, and kept at a constant temperature. A con-

nection was also provided, through which water could be introduced into the manometer by means of a pump. The hydrogen manometer served only as a convenient intermediary, in determining the pressures, for it was calibrated by direct comparison with the big mercurial column established at the Eiffel tower.

The bulb, *AB*, containing the water, was immersed in a bath, *I' I'*, whose contents could be heated, by means of a gas flame, to any desired temperature within the range of the experiments. At the lower temperatures, this bath was filled with mercury; but at the higher temperatures the mercury in the bath was replaced by a mixture of equal parts of sodium and potassium nitrates, which becomes fluid at 200° C., and can be used up to 400° C. The temperature of the bath was obtained by means of thermometers immersed within it; a mercurial thermometer being suggested at *T*, and an air thermometer at *S*. Cailletet and Colardeau give almost no information concerning their thermometry, their only reference to it being this passage: "We employed, in succession, an air thermometer, and two mercurial thermometers which were so constructed as to be capable of measuring temperatures higher than 400° C." The absence of more detail respecting this most important part of the work is to be regretted, as it detracts greatly from the value of their results.

Two insulated platinum wires were led into the steel bulb *CD*, as shown at *EF*; these wires being connected with a pair of electric bells, *GH*, in the manner indicated. In performing the experiments, the temperature of the bath, *I' I'*, was gradually raised, and the pressure was read from the hydrogen gage at frequent intervals, the temperature of the bath being taken also, in every case. As the pressure in the steel tube *AB* increased, mercury was forced over into the lower part of the bulb *CD*. This action was counteracted by forcing more water into the manometer by means of the pump; and the pump was operated until the mercury in *CD* was depressed to a point just below the wire *F*, a state of affairs that was indicated by the bell *H* ceasing to ring. The second bell, *G*, was used merely as a safeguard; for the sounding of this bell was taken as a signal that the mercury was about to be entirely expelled from the tube *AB*, and energetic measures to prevent this were at once taken, either by hastening the action of the manometer pump, or else by lowering the gas flame beneath the bath, *I' I'*.

Cailletet and Colardeau made some sixty experiments with this apparatus, at temperatures ranging from 225° C. up to and beyond the critical temperature. They do not give their actual experimental results, however. These were plotted carefully, on a large scale, and a smooth curved line was drawn as nearly as possible through the various points given by the experiments. The results that they give, and which are reproduced in Table 2, herewith, were obtained from this smoothed curve.

The determination of the critical point, by this method, depends upon the fact that at temperatures below the critical temperature, there is a definite relation between the pressure and temperature of saturated steam; while at temperatures higher than the critical temperature, there is no longer any such relation, since steam and water are then indistinguishable. Cailletet and Colardeau found that their experimental results were all consistent with one another, up to the temperature 365° C.; but that the results obtained at temperatures higher than this depended upon the quantity of water that was

present in the experimental bulb. They therefore concluded that the critical temperature of water is 365° C.; the corresponding critical pressure, according to their experiments, being 200.5 atmospheres. Their method does not afford any means of estimating the critical *volume*.

Cailletet and Colardeau do not describe the method adopted to ensure the purity of the water that they used. Presumably it was of satisfactory purity, but it would have been better to state what precautions were taken in this respect. They say that they had expected to be obliged to coat the interior of their steel experimental bulb with platinum, to guard against the possible decomposition of the water by the steel, at the high temperatures attained in their work; but they add that they looked carefully for evidences of such decomposition, and found none, so that no platinum coating was employed. The same question was raised by Battelli, but he dismissed the matter as unimportant, since Nadejdine, the Russian physicist, had investigated the subject,

TABLE 2.—PRESSURE OF SATURATED STEAM ACCORDING TO THE EXPERIMENTS OF CAILLETET AND COLARDEAU.

Temperature. (Centigrade.)	Pressure in Atmospheres.	Temperature. (Centigrade.)	Pressure in Atmospheres.
225°	25.1	300°	86.2
230	27.5	305	92.2
235	30.0	310	99.0
240	32.8	315	106.1
245	35.5	320	113.7
250°	39.2	325°	121.6
255	42.9	330	130.0
260	46.8	335	138.8
265	50.8	340	147.7
270	55.0	345	157.5
275°	59.4	350°	167.5
280	64.3	355	178.2
285	69.2	360	188.9
290	74.5	365	200.5
295	80.0

and concluded that there is no sensible decomposition under the conditions prevailing in the experimental apparatus.

In conclusion we wish to call attention to a series of experimental determinations of the pressure of saturated steam, extending from 180° C. up to the critical point, which are given by Charles T. Knipp in the *Physical Review*, Vol. 11, 1900, page 129, in an article entitled "The Surface Tension of Water above 100° C." The apparatus employed by Knipp was similar to that of Cailletet and Colardeau. He does not give very full details regarding that part of his work which has to do with the determination of the pressures of saturation; and the pressures that he gives, for the upper part of the range, are materially greater than those given, for the same temperatures, by either Cailletet and Colardeau or Battelli. For these reasons, and also because Knipp's work on the pressures of saturation was only incidental to the investigation of an entirely different subject, we do not quote his results.

Inspectors' Reports.

APRIL, 1907.

During this month our inspectors made 14,743 visits of inspection, examined 27,200 boilers, inspected 11,404 both internally and externally, and subjected 1,241 to hydrostatic pressure. The whole number of defects reported reached 14,704, of which 1,752 were considered dangerous; 55 boilers were regarded as unsafe for further use. Following is a summary of the work of the month, in detail:

Nature of Defects.	Whole Number.	Dangerous
Cases of deposit of sediment.	1,619	144
Cases of incrustation and scale.	3,694	154
Cases of internal grooving.	258	27
Cases of internal corrosion.	1,121	50
Cases of external corrosion.	934	64
Defective braces and stays.	225	66
Settings defective.	584	74
Furnaces out of shape.	641	31
Fractured plates.	359	60
Burned plates.	472	48
Laminated plates.	82	8
Cases of defective riveting.	275	53
Defective heads.	147	20
Leakage around tubes.	1,073	137
Cases of defective tubes.	896	408
Tubes too light.	169	20
Leakage at joints.	455	36
Water-gages defective.	306	63
Blow-offs defective.	420	142
Cases of deficiency of water.	28	11
Safety-valves overloaded.	112	34
Safety-valves defective.	88	29
Pressure-gages defective.	729	56
Boilers without pressure-gages.	15	15
Unclassified defects.	2	2
Total.	14,704	1,752

WE beg to announce the appointment of Mr. Thos. E. Shears as general agent of our (Western) Denver department, in place of Mr. Thomas F. Daly, resigned. The department, especially in view of the extended territory covered, now requires the constant and undivided attention and energy of a general agent, in order that the business may be properly conducted, and the interests of our patrons best conserved.

Mr. Shears will need no introduction to the people of Colorado, for he is now entering upon his twentieth year of continuous service with this company, and as chief inspector of the Denver department.

WE can still furnish copies of our little book entitled *The Metric System*. It is mailed, postpaid to any address, upon receipt of \$1.25 per copy. (An edition printed on bond paper may also be had, at \$1.50 per copy.) Remittances should be sent to the Hartford Steam Boiler Inspection and Insurance Company, Hartford, Conn.

Hartford Steam Boiler Inspection and Insurance Company.

ABSTRACT OF STATEMENT, JANUARY 1, 1907.

Capital Stock, \$500,000.00.

ASSETS.

	Par Value.	Market Value.
Cash in office and in Bank,		\$143,952.21
Premiums in course of collection (since Oct. 1, 1906),		173,449.47
Interest accrued on Mortgage Loans,		26,448.03
Loaned on Bond and Mortgage,		1,047,720.00
Real Estate,		9,450.00
State of Massachusetts Bonds,	\$100,000.00	92,000.00
County, City, and Town Bonds,	326,000.00	340,330.00
Board of Education and School District Bonds,	34,000.00	35,800.00
Drainage and Irrigation Bonds,	3,000.00	3,000.00
Railroad Bonds,	1,439,000.00	1,582,097.00
Street Railway Bonds,	62,000.00	62,250.00
Miscellaneous Bonds,	87,500.00	87,665.00
National Bank Stocks,	41,800.00	60,970.00
Railroad Stocks,	194,200.00	259,201.00
Miscellaneous Stocks,	65,500.00	53,920.00
	\$2,353,000.00	
Total Assets,		\$3,978,245.71

LIABILITIES.

Re-insurance Reserve,		\$1,931,847.29
Commissions and brokerage,		34,680.89
Losses unadjusted,		26,250.80
Surplus,	\$1,485,457.73	
Capital Stock,	500,000.00	
Surplus as regards Policy-holders,	\$1,985,457.73	1,985,457.73
Total Liabilities,		\$3,978,245.71

On December 31, 1906, the HARTFORD STEAM BOILER INSPECTION AND INSURANCE COMPANY had **95,310** steam boilers under insurance.

L. B. BRAINERD, Pres. and Treas. FRANCIS B. ALLEN, Vice-President.
 J. B. PIERCE, Secretary. C. S. BLAKE, 2d Vice-President.
 L. F. MIDDLEBROOK, Assistant Secretary.
 E. J. MURPHY, M. E., Consulting Engineer.
 F. M. FITCH, Auditor.

BOARD OF DIRECTORS.

FRANK W. CHENEY, Treas. Cheney Brothers Silk Manufacturing Co.	JOHN O. ENDERS, U. S. Bank, Hartford, Conn.
CHARLES M. BEACH, of Beach & Co.	LYMAN B. BRAINERD, President and Treasurer, Hartford Steam Boiler Inspection and Insurance Co.
GEORGE BURNHAM, Baldwin Locomotive Works, Philadelphia.	MORGAN B. BRAINARD, Asst. Treasurer Aetna Life Insurance Co.
PHILIP CORBIN, P. & F. Corbin, New Britain, Ct.	F. B. ALLEN, Vice-Prest., Hartford Steam Boiler Inspection and Insurance Co.
GEORGE A. FAIRFIELD, Ex-Prest. Hartford Machine Screw Co.	CHARLES P. COOLEY, Treas. The Fidelity Trust Company, Hartford, Conn.
J. B. PIERCE, Secretary Hartford Steam Boiler Inspection and Insurance Co.	ARTHUR L. SHIPMAN, Corporation Counsel, Hartford, Conn.
ATWOOD COLLINS, Prest. Security Co., Hartford, Conn.	GEORGE C. KIMBALL, Vice-Prest., Smyth Manufacturing Co., Hartford, Conn.
LUCIUS F. ROBINSON, Attorney, Hartford, Conn.	

Carnegie Library,
Pittsburgh, Pa.



Incorporated
1866.

Charter Per-
petual.

The Hartford Steam Boiler Inspection and Insurance Company

ISSUES POLICIES OF INSURANCE COVERING

ALL LOSS OF PROPERTY

AS WELL AS DAMAGE RESULTING FROM

LOSS OF LIFE AND PERSONAL INJURIES DUE TO STEAM BOILER EXPLOSIONS.

*Full information concerning the Company's Operations can be obtained at
any of its Agencies.*

Department.	Representatives.	Offices.
NEW YORK, . . .	C. C. GARDINER, JR., Manager, R. K. McMURRAY, Chief Inspector,	New York City, N. Y., 100 William St.
NORTHEASTERN, .	C. E. ROBERTS, Manager, F. S. ALLEN, Chief Inspector,	Boston, Mass., 101 Milk St. Providence, R. I., 29 Weybosset St.
PENNSYLVANIA, .	CORBIN & GOODRICH, Gen. Agents, WM. J. FARRAN, Chief Inspector,	Philadelphia, Pa., 432 Walnut St.
MARYLAND, . . .	LAWFORD & MCKIM, Gen. Agents, R. E. MUNRO, Chief Inspector,	Baltimore, Md., 13-14-15 Abell Bldg. Washington, D. C., 511 Eleventh St., N. W.
SOUTHEASTERN, .	W. S. HASTIE & SON, Gen. Agts., W. M. FRANCIS, Chief Inspector,	Charleston, S. C., 44 Broad St.
SOUTHERN, . . .	LOUIS V. CLARK & Co., Gen. Agents, H. E. STRINGFELLOW, Chief Inspector,	Birmingham, Ala., 214-216 N. 20th St.
GULF,	PETER F. PESCU, General Agent, R. T. BURWELL, Chief Inspector,	New Orleans, La., 818 Gravier St.
HOME,	E. H. WARNER, General Agent, H. C. LONG, Special Agent, F. H. WILLIAMS, JR., Special Agent, F. S. ALLEN, Chief Inspector,	Hartford, Conn., 650 Main St.
SOUTHERN CONN.,	W. G. LINEBURGH & SON, Gen. Agts.,	Bridgeport, Conn., 1 Sanford Building.
PITTSBURG, . . .	JAMES W. ARROTT, LTD., Gen. Agt., BENJAMIN FORD, Chief Inspector,	Pittsburg, Pa., 401 Wood Street.
NORTHERN OHIO,	C. A. BURWELL, General Agent, H. A. BAUMHART, Chief Inspector,	Cleveland, Ohio, 337 Superior Av., N. W.
NORTHWESTERN,	H. M. LEMON, Manager, JAMES L. FOORD, Chief Inspector,	Chicago, Ill., 169 Jackson St.
SOUTHWESTERN,	V. HUGO, Manager, V. HUGO, Chief Inspector,	St. Louis, Mo., 319 North Fourth St.
WESTERN,	THOS. E. SHEARS, General Agent, THOS. E. SHEARS, Chief Inspector,	Denver, Col., Room 2, Jacobson Bldg.
PACIFIC COAST, .	H. R. MANN & Co., General Agents, J. B. WARNER, Chief Inspector,	San Francisco, Cal., Merchants' Ex. Bldg.

The Locomotive

PUBLISHED BY THE HARTFORD STEAM BOILER INSPECTION AND INSURANCE COMPANY.

VOL. XXVI.

HARTFORD, CONN., OCTOBER, 1907.

No. 8.

Heat-Stresses and the Formation of Cracks.

An article bearing the foregoing title, and written by Mr. Carl Sulzer, appears in the issue of the *Journal of the German Engineers' Association (Zeitschrift des Vereines deutscher Ingenieure)* for July 27, 1907. It is too long to be reproduced in THE LOCOMOTIVE in full, but we have thought that some account of its contents would be of interest. Mr. Sulzer is a well-known German

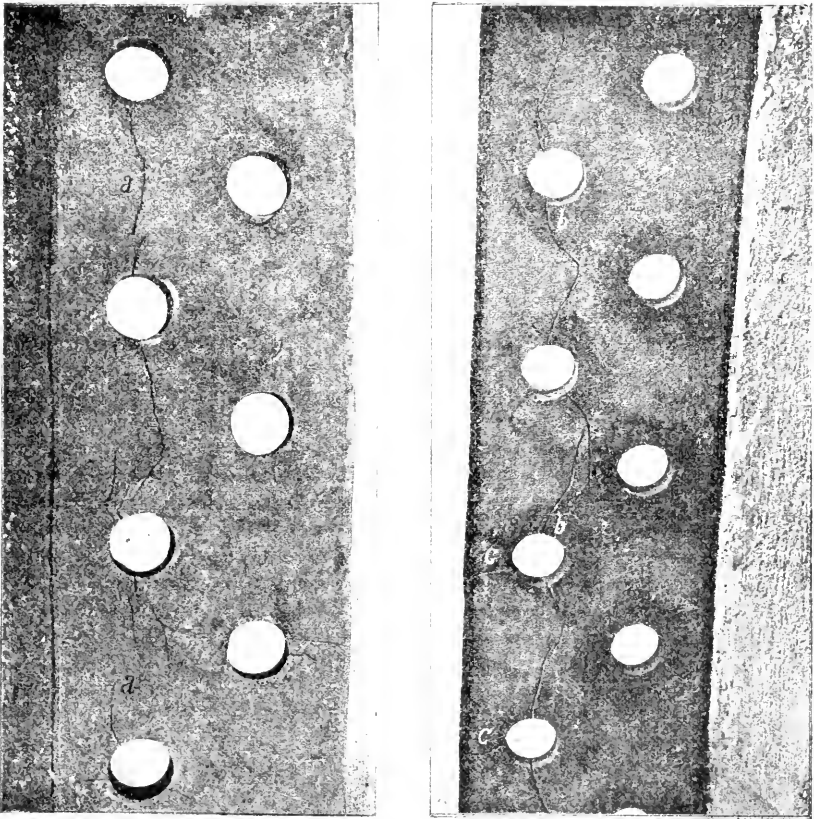

FIGS 1 AND 2. — SHOWING THE CRACKED LAPS OF THE GIRTH JOINT.

mechanical engineer, and what he has to say about the formation of cracks in boiler plates is well worthy of attention. Moreover, he takes as his text a special case which arose in his own practice; and he has taken the pains to investigate, with a thoroughness that is unfortunately rare, the properties of the material that was used in the boiler that he discusses. We therefore give, below, a paraphrase of the most important parts of his article, with which we have incorporated occasional remarks suggested by our own experience along the same lines.

Mr. Sulzer begins by considering the fractures that often occur in castings, on account of the stresses that are produced by the uneven shrinkage of the metal as it cools. Suppose, in the first place, that a bar of cast-iron is heated to 400° or 500° Fahr., and that while it is at this temperature it is placed in a rigid frame in such a way that its ends are held immovably, but yet without putting any stress upon the bar at the outset. The bar begins to cool at once, and if its ends were not fixed, it would contract at the same time, and grow shorter. It cannot shorten, however, because we have supposed its ends to be held in an absolutely fixed position by the frame to which it is secured. As a result, the bar is thrown into a state of tension, and the tension increases as the cooling progresses, and may even become great enough to rupture the bar, if the conditions of the experiment are right.

The method by which Mr. Sulzer calculates the stress that would be produced in such a bar by cooling is the same as that employed for a similar purpose in THE LOCOMOTIVE for March, 1893, page 42. It may be explained as follows: If a bar of metal that is not held at the ends be cooled by a given amount, it contracts and becomes shorter. Now after it has shortened in this manner, suppose we put it into a testing machine, and stretch it back to its original length, without altering its temperature. To do this we shall have to apply a certain amount of force; and we assume, as the basis of our calculation, that the force that is required to stretch it in this manner is equal to the force that we should have had to exert upon it in order to prevent it from shortening as it cooled. The properties of cast-iron are somewhat uncertain, but for the sake of illustration Mr. Sulzer makes certain reasonable assumptions as to these properties, and then calculates the amount of cooling that would be necessary to fracture the bar. He assumes that cast-iron contracts in cooling by 0.001 of its own length, when it falls in temperature by 180° Fahr., provided it is free to do so. On this basis, a bar of this material, free at the ends, would shorten by 0.0015 of its own length, upon being cooled by 270° Fahr. The stress that such an amount of cooling would produce in a bar rigidly held at the ends would therefore be equal (according to the principle explained above) to the stress that we should have to exert in a testing machine to stretch the cold bar by 0.0015 of its own length. But this is approximately equal to the ultimate extension that cast-iron can withstand without rupture; and hence Mr. Sulzer concludes that a bar of this material, held rigidly at the ends while it cools, will fracture when its temperature falls by about 270° Fahr.

Having given this example, our author rightly concludes that moderate differences of temperature may give rise to serious stresses, when the parts that are subjected to such differences are not free to expand and contract. This fact is familiar enough in the case of long lines of steam piping; but we are sometimes apt to overlook the importance of the principle that it involves, when its applicability is less obvious.

Stresses that are due to expansion and contraction arising from differences of temperature will produce cracks very quickly in cast-iron, if they are severe enough, but in mild steel, which is both stronger and more ductile, the cracks that arise from this cause are usually formed gradually, and only after the frequent repetition of the stresses to which they are due; the cracks slowly creeping into the material until the entire section that is affected is penetrated.

Following the foregoing general remarks upon the stresses and fractures that may arise by reason of changes in temperature, Mr. Sulzer enters upon the discussion of a particular case that recently came to his notice, in which a boiler, apparently irreproachable so far as material and workmanship are concerned, was seriously damaged by the development of cracks in its shell, along the girth joints.

The boiler in question was externally fired, and of the two-flue type. It was 23 ft. 7 in. long, and 78 $\frac{3}{4}$ in. in diameter, the shell being 0.52 in. (13 millimeters) in thickness. The flues were corrugated, and each was 33 $\frac{1}{2}$ in. in diameter externally, as measured over the corrugations, and 0.39 in. thick. The total heating surface was estimated at 775 sq. ft., and the grate surface at 25.83 sq. ft. The boiler was intended to work under a gage pressure of 7 atmospheres, or 103 lbs. per sq. in., and it was tested to 12 atmospheres, or 176 lbs. The shell was built in five courses, or rings, the longitudinal joints being of the double-strap butt type, while the circular (or girth) joints were of the lapped type, and double riveted. Particular note should be taken of the fact that the girth joints were *double* riveted, not only because this is essential to an understanding of the trouble that developed, and which will presently be described, but also because the boiler departed, in this respect, from current practice in the United States, where the girth joints are almost invariably single riveted. The diameter of the rivet holes was 0.866 in. (22 millimeters), and the pitch of the rivets in the girth joints was 3.35 in. (85 millimeters), the two rows being symmetrically staggered ("gleichmässig gegeneinander versetzt").

The boiler under consideration was built in 1899, by Sulzer Bros., of Winterthur, Germany; our author himself being a member of this firm (if we understand correctly), and hence being highly competent to describe correctly the methods of construction there employed. Siemens-Martin mild steel ("Flusseisen") of firebox quality was used throughout the boiler except for the rivets, which were of best wrought-iron ("Schweisseisen"). Five tests made at the rolling mill upon samples of the shell plates showed an average tensile strength of 52,541 lbs. per sq. in., and an elongation of 30.1 per cent.; the form of the test-pieces not being stated. Two corroborative tests, made upon samples of the same material at the Zurich testing institution, gave an average tensile strength of 48,786 lbs. per sq. in., and an elongation of 30.9 per cent. It will be noted that this tensile strength is lower than that obtained at the rolling mill; but Mr. Sulzer states that the tensile strengths determined at Zurich frequently show this peculiarity. The limit of proportionality of stress to strain ("Streckgrenze"), as found at Zurich, occurred at 36,127 lbs. per sq. in., and the observed contraction of area at fracture was 69 per cent.

Two chemical analyses were made at Zurich, of the material composing the boiler plate, with the following average results: Total carbon, 0.048 per cent.; silicon, 0.016 per cent.; manganese, 0.289 per cent.; sulphur, 0.040 per cent.; phosphorus, 0.016 per cent.

The foregoing tests, both chemical and physical, indicate that the material that was used in the shell was of excellent quality.

Regarding the workmanship, our author states that it was also of the highest character; Messrs. Sulzer Bros. being provided in all respects with the best tools and appliances for work of this sort. In their plant the shell-plates are bent cold, upon a special machine which ensures the proper curvature up to the edges of the plate, so that subsequent hand-work upon these edges is avoided. The circular edges and all calking edges are then worked up on special machines, and the ends of the several courses are brought to size by means of accurate steel measuring rings, so that the inner and outer courses may fit into each other so snugly that no subsequent adjustment will be necessary. All the holes are drilled from the solid plate, and the parts that are to fit are set together before the drilling, so as to ensure the holes coming absolutely opposite to one another. After the drilling, the parts are separated, and the burrs removed. Local heating during construction is rendered unnecessary by the use of double-strap riveting on the longitudinal joints. The riveting is performed upon a hydraulic riveter, the pressure of which can be adjusted according to the size of the rivet by means of an accumulator, the load upon which can be varied at will. The riveting machine is also provided with a device of approved character for closing the plates tightly together before driving the rivets. The calking is done, whenever the thickness of the plates makes this practicable, with pneumatic tools. "It may indeed be said," adds Mr. Sulzer, "that every imaginable precaution is taken, and that the best workmanship is ensured by these methods, which are in strong contrast with the inadequate or improper ones that are still in use in many other shops."

The boiler under discussion was built in accordance with the methods described above, and was installed for service in the early part of January, 1900. So far as can be established at the present day, it was in 1905 that trouble was first observed, in the form of a number of leaks along the rear girth joint of the second course of the boiler. These were calked. Serious leaks, especially along the circular joint next in front of the rear one, developed in January, 1906, and again in February, 1907, and these were also calked. In April, 1907, similar leaks were once more observed, and this time the trouble was so serious that calking would no longer serve, and the matter was called to the attention of the builders of the boiler. A closer investigation showed that cracks had developed around several of the circular joints, in both the inner and the outer plates; and it was found that these were serious enough to require a patching of the shell.

The nature of the cracks, as well as their position and direction, indicated that the boiler had been heated above its normal working temperature; and further inquiry disclosed the fact that the boiler had been pushed to its utmost capacity for a long period. Mr. Sulzer estimates, indeed, that the evaporative duty that it was actually forced to perform was approximately double that which should be expected, normally, from a boiler of this type; and he states that this was made possible by the fact that the chimney of the plant was made unusually large, with the idea of providing a sufficient draft to take care of additional boilers that might be added in the future. The demands upon the boiler that led to its being forced in this manner also limited the time that could be devoted to cleaning it, so that when it was shut down it was cooled off very quickly, and was fired up again as speedily as possible, in order that it might be placed in operation without delay. It does not appear that the boiler had ever been seriously troubled with scale, for, so far as could be learned, none had been

found within it having a thickness greater than a tenth of an inch or so (2 to 3 millimeters).

The cracks that Mr. Sulzer is discussing, it should be clearly observed, are those that occur along the *girth joints*,—the lap-joint crack that sometimes develops along the longitudinal joint, and which has been discussed in THE LOCOMOTIVE on several occasions, was not found in his boiler, and is here entirely omitted from consideration. The girth-joint cracks to which he confines his attention are of the three kinds that are illustrated in Figs. 1 and 2, which show sections of plate cut from one of the girth joints of the boiler described above; the section shown in Fig. 1 being cut from the inner course, or ring, while that shown in Fig. 2 was taken from the outer course. Three kinds of such cracks are to be distinguished.

First, cracks, like *a*, running circumferentially in the inner plate-ring, along the inner row of rivets thereof, and starting from the outer surface of the plate;

Second, cracks, like *b*, also running circumferentially, but lying in the outer plate-ring, along the outer rivet-row thereof, and starting from the outer surface of the plate; and

Third, cracks, like *c*, in the outer plate-ring, running in the general direction of the length of the boiler, from the outer row of rivet holes to the edge of the plate.

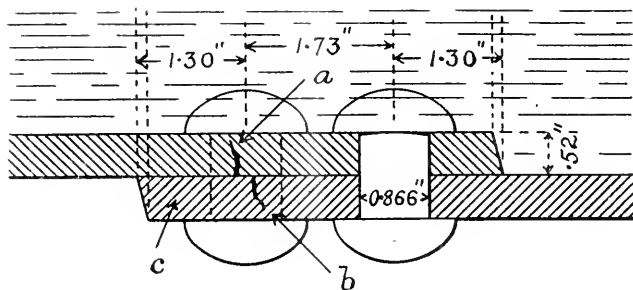

FIG. 3.—DIAGRAM OF THE AFFECTED GIRTH JOINT.

The cracks shown at *a* and *b* did not actually perforate the plate, but the cracks *c* ran through it from one surface to the other. The heavy caulking marks that are to be seen in the illustrations were not produced in the shop of the manufacturer, but were made subsequently by unskillful workmen, in the attempt to stop the leakage that had developed at these joints.

Mr. Sulzer points out that the cracks that he shows could not have been produced by the steam pressure in the boiler, because the longitudinal joints, which were subject to much greater stress from this cause, were entirely unaffected. He also says: "Nor can we properly regard them as ordinary fire-cracks, such as are formed when the heated shell is suddenly cooled in any way, so that the superficial layers of the material shrink, while the deeper ones, cooling more slowly, retain their original dimensions, and thereby cause the exposed surface of the plate to crack open. The cracks shown in the illustrations plainly originated on the surfaces of the two plates that were turned towards each other, where there was no possibility of a local cooling." He considers (and he is probably correct) that the real cause is to be sought for in the expansion and contraction of the strip of plate that lies between the two rows of rivet holes.

If we try to picture to ourselves how the temperature varies as we pass from one part of the affected girth joint to another, when the boiler is in operation under heavy duty, we shall arrive at something like the distribution shown in Fig. 4, where the intensity of the temperature is indicated, in a general way, by the depth of the shading; the darkest regions corresponding to the regions of highest temperature. The heat that passes from the furnace into the outer plate is carried away, in part, by conduction in this plate (towards the right in the illustration), and in part it is transmitted directly through the two plates (upward in the illustration) towards the water in the boiler, although there is considerable resistance opposed to its passage in this last-mentioned direction. The general effect is, that there is a sort of accumulation of heat in the outer plate, as is suggested in the diagram. It is to be noted, too, that the temperature of the inner lap of the joint is lower than that of the outer one, not only because the inner lap is nearer to the water, but also because a certain proportion of the heat that enters the outer one does not enter the inner one at all, passing away to the right by conduction through the outer sheet, as already explained.

To understand the effect of temperature-differences of this sort upon the

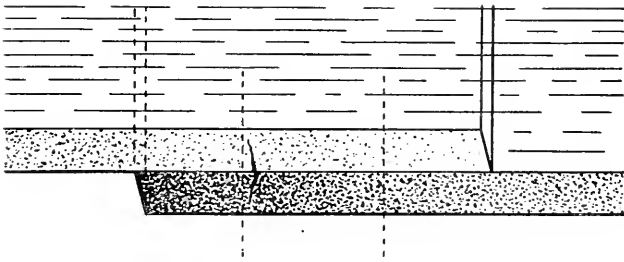

FIG. 4.—ILLUSTRATING THE DISTRIBUTION OF TEMPERATURE IN THE PLATES.

joint, let us consider the boiler, first, in the cold state, as it came from the builder. We will suppose that the rivets fitted the holes perfectly, and that there was no strain upon the shell at all, except such as might be due to the weight of the boiler and its contents. In fact, since the strains that are due to the weight of the boiler, and to the steam pressure, are small in comparison with those that are due to the differences of temperature, and are therefore of no importance so far as this particular discussion is concerned, we may as well omit them from consideration altogether; and we shall therefore speak of the boiler throughout what follows, as though the temperature stresses were the only ones to which it is subject.

The boiler being at the outset of a uniform temperature, and free from stress, let us see what will happen when it is fired up, and forced so hard that the outer lap of the girth joint becomes considerably hotter than the inner one. The outer lap, by reason of this difference of temperature, will tend to expand. The part of it which lies between the two rivet rows is not free to expand, however, because it is held in the length-wise direction by the two rows of rivets, while in the circumferential direction it is also confined by the consecutive rivets in the girth joint. The result will be, that the portion of the outer lap that lies between the rivet-rows will exert a pressure against the rivets, in a direction tending to separate the rows, and this means that the inner lap will

be subjected to a tension, and the outer one to a compression; and the stresses in the two laps will be most intense along the surfaces where the two plates are in contact.

It is impossible to calculate the magnitudes of the forces that thus arise in the plates, to any close degree of approximation, in the absence of accurate data concerning the temperatures of the plates, and their elastic properties; but by the method outlined in the early part of this article in connection with cast-iron, Mr. Sulzer arrives at the general conclusion that mild steel plates, having properties such as are found in practice, might be strained to their elastic limit, in the space between the rivet rows of the girth joint, if the outer lap were hotter than the inner one by as much as 180° Fahr. Such a difference of temperature is quite possible, when the boiler is forced; and hence we must conclude that the temperature stresses in the two laps may easily be great enough to strain them both to their elastic limit. If, now, the difference of temperature is greater than this difference which suffices to bring both laps to their elastic limit, it follows that each will take a permanent set, the outer one being compressed, and the inner one stretched; so that there will be a tendency to form the cracks shown at *a*, in Figs. 1 and 3.

When the boiler cools, so that the temperature-difference between the two laps disappears, the free shrinking of the outer lap (which has been permanently shortened by the compression) will be opposed by the resistance of the inner one (which has been stretched by the tension), and the conditions of stress will be reversed, with the result that there will be a tendency to form the cracks shown at *b*.

It will be seen, therefore, that the parts of the plates that lie near and between the two rows of rivets of the girth joints are subjected to stresses, alternately compressive and tensile, which are (or may be) severe enough to actually crack the plates; and which, when such cracks are once started, will cause them to creep gradually into the metal, until it is ultimately perforated or destroyed. Mr. Sulzer, however, speaks of the cracks in the outer lap as most likely to form along the outer row of rivet holes, and of those in the inner lap as most likely to form along the inner row. We do not quite see why, according to his theory, they are not equally likely to form along either row of holes, in either plate.

Similar relations prevail with respect to the girth-wise stresses. In the heated boiler the outer lap tends to expand in the circumferential direction, but this expansion being opposed by the rivets that unite the two plates, it follows that the outer plate is subjected to a compressive stress and the inner one to a tension, a permanent set occurring in each case if the difference of temperature of the two laps is great enough. The rivets themselves are thrown into tension at the same time, and in the Sulzer boiler a number of heads were found to be broken off, probably from this cause. When the boiler cools off again, the contraction of the shortened exterior lap is resisted by the inner lap, with the result that the outer plate is thrown into tension, and this, if severe enough, will give rise to the longitudinal cracks. *c*. (It should be observed that the girth-wise stress does not necessarily have the same intensity around the entire circumference of the boiler. It may vary from one rivet-space to the next; and as a matter of fact, the crack formation occurs only where the temperatures have obviously been highest.)

Specimens were cut from the Sulzer boiler, in the immediate vicinity of the cracks, and carefully investigated, to see if the properties of the material had sensibly changed in the seven years of service. One section of plate, including a crack, was ground and polished, and subsequently etched; but no signs of deterioration could be observed. A number of pieces were tested on the Zurich testing machine, with the following average results:

Property Determined.	Test Specimens perpendicular to Girth Joint.	Test Specimens parallel to Girth Joint.
Tensile strength (lbs. per sq. in.).....	47,079	48,075
Elastic limit ("Streckgrenze").....	34,563	29,730
Reduction of area (per cent.).....	61	66
Elongation (per cent.),	30.0	27.2

All the fractured surfaces were described as "finely fibrous."

A comparison of these results with the results obtained at Zurich (and therefore made by the same methods) from test-pieces taken from the material in its original condition show no very marked changes; the numerical differences being no greater than might perhaps be expected in the normal course of events, when a number of presumably identical specimens are tested.

It was found, also, that the plate, after its seven years of service, could be bent flat upon itself, either hot or cold, without fracture. Between two consecutive rivet-holes (the two end ones in Fig. 5) a hole was then drilled having a diameter (0.866 in.) equal to the diameter of the rivet holes themselves; and this test hole was then enlarged in the cold by driving a taper pin into it until the diameter had been increased 36 per cent. (namely, to 1.18 in.); but this treatment did not produce the smallest sign of a crack.

In view of these various facts, Mr. Sulzer's conclusion that the cracks are to be attributed to temperature-differences between the laps of the double-riveted girth joints, rather than to any imperfection or deterioration in the material, appears to be quite justified.

In conclusion, our author points out that the immediate cause of the trouble lay in forcing the boiler beyond its reasonable capacity; and he suggests (quite properly) that boiler inspectors take especial care to assure themselves that the boilers they examine are not being similarly forced. "It may also be asked," he says, "if metallurgical science cannot produce plates that shall be better able to resist the kind of stresses that we have described. The considerations advanced above indicate that the improvement should be in the direction of raising the elastic limit, or diminishing the modulus of elasticity. A lowering of the modulus of elasticity would mean the production of a material that would experience a given change of length by the application of a tensile or compressive force less than is required in the material now used."

In regard to the matter of design, he expresses himself as preferring a single riveted girth joint to the double riveted one, "whenever the strength of the single joint is sufficient." There is some satisfaction in noting this particular conclusion, as it is in accord with the practice that has prevailed in the United States for many years past.

In his final paragraph, Mr. Sulzer says: "The facts here narrated indicate that the calking of the inner plate-edge, that is in contact with the water, would be likely to make the joint more permanently tight than it can be expected to be when the calking is done on the outer edge, which is subjected to greater variations of temperature." We cannot entirely agree with him here. The internal edges of plates are sometimes calked in this country; but when this is done, the outer edges are usually calked also, for a variety of reasons. In the first place,

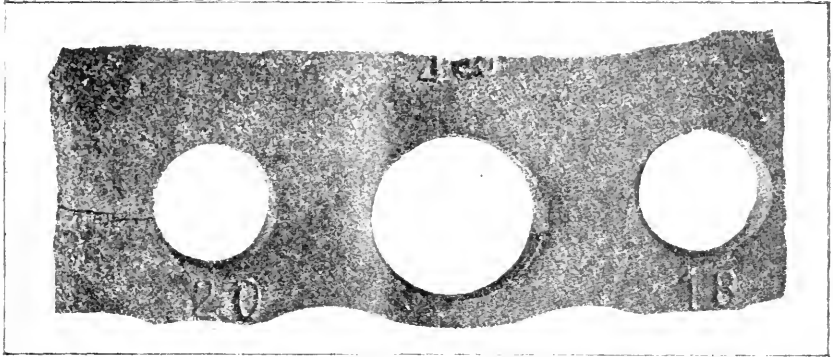

FIG. 5.—ILLUSTRATING THE TAPERED-PIN TEST.

if leakage develops at the joint from any cause, after the boiler is put in service, it is difficult to re-calk the inner edge of the plate, because it is almost inaccessible; and therefore the outer edge will have to be calked, anyhow, in case of such leakage developing. Again, leakage is sometimes due to the fact that certain of the rivets do not fill their holes perfectly, so that water finds its way under the heads of such rivets, and so into the space between the laps of the sheets; and a leakage of this nature obviously would not be prevented by internal calking alone.

Boiler Explosions

JUNE, 1907.

(197.)—A tube ruptured, June 1, in a water-tube boiler in the power station of the Philadelphia Rapid Transit Co., Second and Wyoming Sts., Philadelphia, Pa.

(198.)—A small hot water boiler exploded, June 3, in Jacob Miller Sons & Co.'s shirt factory, Philadelphia, Pa.

(199.)—A number of cast-iron headers fractured, June 3, in a water-tube boiler at the Semet Solvay Co.'s plant, Lebanon, Pa.

(200.)—On June 5 a tube ruptured in a water-tube boiler at the Milwaukee Coke & Gas Co.'s plant, Milwaukee, Wis. Fireman Ernest Zaeska was severely injured.

(201.)—The boiler of Matthew Van Kuren's sawmill exploded, June 6, near Warrensburg, N. Y. Arthur Van Kuren, a son of the owner, was killed. The property loss was estimated at about \$2,500.

(202.)—A boiler ruptured, June 7, at the Jacob Stickle plant of the Dayton Breweries Co., Dayton, Ohio.

(203.)—On June 8 a boiler exploded in Zulauf & Sons' flouring mill, Wilsonville, Neb. Engineer Lewis Foley was instantly killed, head miller Frank Armstrong was severely injured, and the mill was wrecked.

(204.)—A tube ruptured, June 9, in a water-tube boiler at the plant of the Bristol Gas & Electric Co., Bristol, Tenn.

(205.)—Several cast-iron headers ruptured, June 9, in a water-tube boiler at the Coronado Hotel, Coronado Beach, Cal.

(206.)—A boiler belonging to the Jennings Canal Co. exploded, June 11, at Jennings, La.

(207.)—A boiler exploded, June 11, at the water works and electric light plant, Shelbyville, Ind., wrecking the plant. Engineer William Ballard was killed.

(208.)—A tube exploded, June 11, in a water-tube boiler of the plant of the Combination Rubber Mfg. Co., Bloomfield, N. J. Joseph Kreeveda and Joseph Krolomuski were injured.

(209.)—On June 11 a tube ruptured in a water-tube boiler at the Milwaukee Coke & Gas Co.'s plant, Milwaukee, Wis. Charles Ammon and August Borowski were injured.

(210.)—A tube ruptured, June 12, in a water-tube boiler at the power station of the Brooklyn Heights Railroad Co., Third Ave. and Second St., Brooklyn, N. Y. Walter Brown, John Gillin, Joseph Brazier, William Lee, and Samuel McKenzie were injured. (See the next item.)

(211.)—On June 12 a tube ruptured in a water-tube boiler at the power station of the Brooklyn Heights Railroad Co., Third Ave. and Second St., Brooklyn, N. Y. José Romero was seriously scalded. (Compare the last item. The two explosions are counted separately, because they were quite distinct, with an interval of three-quarters of an hour between.)

(212.)—A blowoff pipe failed, June 12, at the Hanging Rock Iron Co.'s plant, Hanging Rock, Ohio.

(213.)—On or about June 13, a boiler exploded on the steamboat *Tanaza*, near Fairbanks, Alaska. Lane Lewis was killed, and James Galbreath was fatally injured.

(214.)—A boiler exploded, June 14, at the machine shop of the Westinghouse Company, Wilmerding, Pa. Frank Morgan, who was testing the boiler at the time, was injured so badly that he died on the following day.

(215.)—The boiler of a steam plow exploded, June 15, four miles west of Selby, S. Dak. Oscar Baker, Samuel Baker, and Washington Koehler were killed, and W. H. Carlo, owner of the outfit, was fatally injured.

(216.)—On June 15 a boiler exploded in Blakley's sawmill, three miles from Lyles, Tenn. Wade Bates, William Nelson, Race Goulden, and Mrs. Quillie Tidwell were seriously injured, and Monroe Nelson and Mr. Blakley (the owner) received injuries of lesser severity. The mill and machinery were wrecked.

(217.)—A blowoff pipe ruptured, June 17, in the plant of the United States Crushed Stone Co., McCook, Ill. Fireman Moses Van Ort was injured.

(218.)—A small boiler used for heating a roofing preparation exploded, June 17, at Niagara Falls, N. Y. Fire followed the explosion, and the loss was about \$1,500.

(219.)—A boiler exploded, June 17, at the planing mill plant of Colbert Brothers' Novelty Works, Andrews, Ind. William Mote was killed, and Phil Willets and William Gift were injured. The property loss was estimated at \$1,000.

(220.)—A small boiler, temporarily installed in the basement of the Peabody Hotel, Memphis, Tenn., exploded June 18.

(221.)—The boiler of the locomotive drawing freight train No. 1140, of the Denver & Rio Grande railway, exploded, June 19, one mile east of Florence, Colo. Engineer Thomas Ewing, fireman W. G. O'Brien, and head brakeman C. B. Gooch were instantly killed. The locomotive was completely demolished, the train was wrecked, and the track and road bed were torn up for several hundred feet.

(222.)—The boiler of locomotive No. 666, of the Cincinnati, New Orleans & Texas Pacific railway, exploded, June 19, at Boyce Station, near Chattanooga, Tenn. Fireman D. L. Haynes was fatally injured, and the locomotive was wrecked.

(223.)—On June 22 a tube ruptured in a water-tube boiler at the Pennsylvania Steel Co.'s blast furnace, Chester, Pa.

(224.)—The boiler of a locomotive on the Peoria, Pekin & Terminal railway exploded, June 22, near Peoria, Ill. Wilbur Melton was severely scalded, and several others received slight injuries.

(225.)—On June 24 a boiler exploded in H. Vandolah's sawmill, near Palmersville, Tenn. Charles Brooks was instantly killed, and Samuel Bostick, Blaine Biggers, and Mr. Vandolah (owner) were scalded. The property loss was estimated at \$5,000.

(226.)—A tube ruptured, June 24, in a water-tube boiler at the plant of the Penn American Plate Glass Co., Alexandria, Ind. Adam Landerdale was injured.

(227.)—A boiler exploded, June 24, in F. G. Maywald's grist mill, Plantersville, Tex. The building was wrecked, and Mr. Maywald and his son were scalded.

(228.)—On June 27 a tube ruptured in a boiler at the Halcomb Steel Co.'s plant, near Syracuse, N. Y. Anthony Avery was burned.

(229.)—A tube ruptured, June 28, in a water-tube boiler at the Seaview Ave. power house of the New York, New Haven & Hartford railroad company, Bridgeport, Conn. Martin Harrington was injured so badly that he died a few days later. W. A. Dow was also burned about the hands, while rendering assistance to Harrington.

(230.)—A boiler exploded, June 28, in Wittenmyer & Lovell's sawmill, at Benton Ridge, Ohio.

(231.)—A boiler exploded, June 28, on Nineteenth Ave., San Francisco, Cal. Fireman James Westbrook was badly burned.

(232.)—A boiler exploded, June 29, on Milton Stewart's oil lease, Cherry-tree township, Pa., demolishing the boiler house.

(233.)—A steam brick-hardening cylinder exploded, June 29, at the plant of the Schenectady Sandstone Brick Co., Schenectady, N. Y. John Curns and C. Wheland Servey were killed, and the plant was considerably damaged. It is said that the accident was due to the workmen starting to remove the cover of the tank, while the interior was still filled with steam at a heavy pressure.

JULY, 1907.

(234.)—A tube ruptured, July 4, in a water-tube boiler at the power station of the Buffalo Southern Railway Co., Buffalo, N. Y. (Compare the next item.)

(235.)—On July 4 a tube ruptured in a water-tube boiler at the power station of the Buffalo Southern Railway Co., Buffalo, N. Y. (This explosion is counted separately from the last, because the ruptured tube was in a different boiler.)

(236.)—A rendering tank exploded, July 6, in the Twin City Rendering Co.'s plant, Rock Island, Ill. Engineer Thomas Clinton was slightly scalded, and the building was badly damaged.

(237.)—A boiler ruptured, July 6, at the Federal Coal & Coke Co.'s plant, Grays Flats, W. Va.

(238.)—On July 9 a boiler exploded in the gas works at Pekin, Ill.

(239.)—On July 9 a boiler ruptured at the Sterling mine of the Consolidated Connellsville Coke Co., Uniontown, Pa.

(240.)—A tube collapsed, July 9, in a boiler at the paper mill and roofing factory of the Ford Mfg. Co., Vandalia, Ill. Cody Crotser was scalded.

(241.)—A boiler ruptured, July 10, on the United States tug *Pontiac*, some miles southeast of Montauk, Long Island.

(242.)—A boiler exploded, July 10, in the Garner flouring mill, at Iberia, Mo. The building was entirely wrecked.

(243.)—On July 10 a boiler ruptured in Charles F. Autz's ice factory, Jeffersonville, Ind.

(244.)—A tube ruptured, July 14, in a water-tube boiler at the power house of the Astoria Electric Co., Astoria, Ore. Engineer Jasper A. Pedersen and fireman Levy Larsen were injured.

(245.)—On July 14 a tube ruptured in a water-tube boiler at the Nazareth Cement Works, Nazareth, Pa. Fireman Michael McConnell was scalded.

(246.)—A blowoff pipe ruptured, July 16, in the yarn mill of the Riverside Mfg. Co., Anderson, S. C. Irving Payne was scalded.

(247.)—A cast-iron header fractured, July 16, in a water-tube boiler at the Pa-cagoula Street Railway Power Co.'s plant, Scranton, Miss.

(248.)—On July 17 the boiler of a Southern Pacific locomotive exploded on the main line of the Central Pacific railway, at Penryn, a small station 28 miles east of Sacramento, Cal. Engineer C. L. Deming and fireman D. W. Bryant were injured.

(249.)—A tube ruptured, July 18, in a water-tube boiler at the plant of the Kosmos Portland Cement Co., Kosmosdale, Ky.

(250.)—The boiler of locomotive No. 1642, of the Union Pacific railway, exploded, July 18, at Lathem, west of Rawlins, Wyo. An unknown man, who was riding with the crew, was instantly killed, and engineer Robert C. Aikins, fireman E. B. Berry, and head brakeman Charles Howard were seriously injured.

(251.)—A boiler exploded, July 19, at the Cleveland Twist Drill Co.'s plant, Cleveland, Ohio. Charles Hutchinson was injured

(252.) — A tube ruptured, July 22, in a water-tube boiler in the piano factory of the Krell-French Piano Co., Newcastle, Ind. Fireman T. J. Spears was slightly scalded.

(253.) — On July 23 a tube ruptured in a water-tube boiler at the Delaware & Hudson Co. iron works, Standish, N. Y.

(254.) — The crown sheet of a firebox boiler failed, July 23, at the No. 3 shaft of the Winona Copper Co., Winona, Mich.

(255.) — A boiler exploded, July 25, in the Wilson Brick & Tile Co.'s plant, New Haven, Ky. Wellington Brown was killed, and Dolan Halbert was fatally injured. Victor Bowling, Charles Mitchell, and David and Elmer Halbert were also injured more or less seriously, but not fatally. The plant was wrecked.

(256.) — On July 25 several cast-iron headers broke in a water-tube boiler at the plant of the McCullough Iron Co., Wilmington, Del.

(257.) — The boiler of a locomotive attached to a Wabash freight train exploded, July 26, one mile east of Simcoe, Ont. Engineer Benjamin Patterson and fireman James Calvert were instantly killed, brakeman Lewis Warton was fatally scalded, and conductor Buck was injured badly but not fatally. The locomotive was destroyed.

(258.) — The boiler of a Great Western locomotive exploded, July 27, at Bondurant, Iowa. Fireman Lee was killed.

(259.) — On July 28 a boiler accident occurred at the plant of the Southern Steel Co., Graves Mine, Jefferson Co., Ala.

(260.) — The boiler of a freight locomotive exploded, July 29, on the Southern Pacific railway, at West Berkeley, Cal. Engineer James McLaughlin and fireman Irving McAfee were seriously injured. The train was wrecked.

(261.) — A boiler exploded, July 30, in a sawmill near Custer, S. Dak., instantly killing the owner, Frederick Scofield. Theodore Shoemaker and R. J. Turner were also slightly injured.

(262.) — Walter A. Petrie, engineer at the North American Storage Co.'s plant at Paynesville, Minn., was seriously injured, July 30, by the blowing off of a manhole cover.

(263.) — The boiler of a fast freight locomotive exploded, July 30, on the Illinois Central railway, at Sitka, three or four miles south of Milan, Tenn. Five men were killed, nine others were seriously and perhaps fatally injured, and the property loss was heavy.

(264.) — On July 30 a boiler exploded in the plant of the Frost-Sibley Lumber Co., Lamison, Ala. Thomas Moore was instantly killed, Eustace Dumas and William Parnell were fatally injured, and Anthony Stewart was injured seriously but not fatally.

(265.) — The boiler of Burlington locomotive No. 21 exploded, July 31, about two miles east of Breckinbridge, Mo. Head brakeman M. Hall, fireman Patrick Brewer, and a student fireman, whose name we do not know, were killed, and engineer Samuel Roberts was fatally injured. The locomotive was wrecked.

The Locomotive.

A. D. RISTEEN, PH.D., EDITOR.

HARTFORD, OCTOBER 25, 1907.

THE LOCOMOTIVE can be obtained free by calling at any of the company's agencies.

Subscription price 50 cents per year when mailed from this office.

Bound volumes one dollar each. (Any volume can be supplied.)

THE People's Surety Company, of Philadelphia, has ceased writing steam boiler insurance, and has reinsured all of its business of this character in the Hartford Steam Boiler Inspection and Insurance Company.

THE present issue of THE LOCOMOTIVE completes the twenty-sixth volume. When the paper was published monthly, each volume included the twelve copies printed during the calendar year; but since January, 1904, it has been published quarterly, and each volume now runs through two years. Indexes and title pages may be had upon application to the Hartford office of this company. The volume may also be had in bound form, at the usual price of one dollar a copy.

THE Hartford Steam Boiler Inspection and Insurance Company has secured the services of Mr. W. R. C. Corson, as assistant to Mr. Frank S. Allen, in its mechanical engineering department. Mr. Corson was graduated from Yale in 1891, and in the fall of that year he entered the employ of the Eddy Electric Manufacturing Company, of Windsor, Connecticut, working first in the shop and then in the engineering department, after which he successively occupied the offices of engineer, superintendent, and secretary of the corporation. When the Eddy company was discontinued, Mr. Corson established himself as a consulting engineer at Hartford, and built up a large private practice. Among his clients are numbered many of Hartford's manufacturing concerns, for whom he has planned systems of power, lighting, or heating. The electric and power installation of the Groton & Stonington Street Railway, of Connecticut, and that of the Northern Electric Street Railway Company, of Scranton, Pennsylvania, were planned in his office. He was chief consulting engineer of the Berkshire Power Company, of Canaan, Connecticut, and he designed and constructed the new water supply system of the Windsor Water Company, Windsor, Connecticut.

Mr. Corson is a member of the Connecticut Society of Civil Engineers and the American Electro-Chemical Society, and an associate member of the American Institute of Electrical Engineers. He is also identified as a director or trustee with many of Hartford's institutions, among them the Ætna National Bank, the Wadsworth Atheneum, the Watkinson Library, the Retreat for the Insane, and the American School at Hartford for the Deaf.

Early History of the Mechanical Equivalent of Heat.

It is hard to realize that up to about a century ago, heat was almost universally believed, even among the most advanced physicists, to be a material substance, — subtler, indeed, than brick or stone, or even than air, but nevertheless a substance of some kind. Whether it possessed weight or not was a question upon which authorities were divided; and Count Rumford (see "An Inquiry Concerning the Weight of Heat," *Philosophical Transactions*, 1799) made careful but of course unsuccessful experiments to see if he could detect such weight; his general conclusion being that "all attempts to discover any effect of heat upon the apparent weights of bodies will be fruitless."

We cannot undertake to explain the old substantive, or "caloric" theory in full, but the fundamental idea of it was, that heat, or "caloric," is a subtle substance which can exist either in the free state (in which case it was supposed to be sensible to the touch and measurable by the thermometer), or in combination with grosser matter (in which case, being no longer sensible either to the touch or to the thermometer, it was said to be "latent"). When sensible heat was generated by chemical action, it was believed that some of the caloric that had previously been in combination with the substances that were concerned in the chemical reaction was set free: when a gas was warmed by compression, it was thought that some of the caloric that existed in the uncompressed gas in the combined or "latent" state was squeezed out by the act of compression; and when heat was apparently generated by friction, it was believed that caloric was rubbed out of the bodies that were concerned in the friction.

The theory of the nature of heat that we have just sketched in so crude a manner was believed to be true, by practically every man of science, up to the end of the eighteenth century. After that, different views came to be held by a few of the more advanced thinkers; but even in 1824 we find as great an authority as Carnot adhering, formally, to the caloric theory, although it appears from his private notes, published many years later, that he soon afterwards had grave doubts, in his own mind, of its correctness. It was not until the decade beginning with the year 1847, however, that men of science abandoned the old theory entirely and absolutely, and adopted the one that is now held.

According to our present views, which appear to be substantiated by an incalculable mass of experimental evidence, heat is not a material substance, any more than force or consciousness are. The caloric theory taught that heat could never be created nor destroyed; and when work was performed by a steam engine, the work was considered to be merely an accompaniment of the passage, in undiminished amount, of a certain quantity of caloric from a region of high temperature to a region of lower temperature (for example, from the boiler to the condenser, or from the boiler to the air). But according to our present view, the performance of work by a heat-engine is accompanied by an actual *destruction* of heat; so that for each foot-pound of mechanical work that is performed, a perfectly definite quantity of heat disappears, and actually ceases to exist in the form of heat. If we take, as our unit of heat, the quantity of heat that is required in order to raise the temperature of one pound of water from 59° to 69° Fahr., then we know, by experiment, that whenever heat is transformed into mechanical energy, or mechanical energy into heat, the transformation takes place in such a manner that for every such unit of heat that

ceases to exist as heat, there are some 780 foot-pounds of mechanical work performed by the engine; and conversely, for every 780 foot-pounds of mechanical energy that is converted into heat in any manner, whether by frictional processes or otherwise, there is generated precisely one unit of heat. This number (780 with the system of units here adopted), which shows how much mechanical energy is developed by the destruction of one unit of heat, is called the "mechanical equivalent of heat"; and the purpose of the present article is to review the circumstances attending the discovery of the existence of this equivalent.

In reading the papers that were written by experimenters and engineers previous to the middle of the nineteenth century, allowance must be made for the fact that certain highly convenient words, which are essential to a clear expression of physical ideas, had not at that time been introduced. Thus we find the early writers using the word "force" both in the sense in which it is now employed, and also to express the capacity of a body, or of a physical system of any kind, to perform mechanical work; the word "energy" being now used to express this latter idea. This double use of the word "force" led to great confusion, as might be shown by citations from as clear a thinker and as competent a physicist as Faraday. The word "energy" was suggested by Young, about 1807, but it was not adopted until nearly fifty years later. The English expressions "dynamical energy" and "statical energy" were introduced by Lord Kelvin in 1852; the first to signify the energy that a body has by reason of its being in motion, and the second to signify the energy that it has by reason of its being raised above the surface of the earth (like a clock weight), or by reason of its being in a state of stress (like a watch spring). These terms were afterwards abandoned by Kelvin in favor of the respective terms "actual energy" and "potential energy," that were introduced by Rankine; and in 1862 Kelvin and Tait made one more change, by substituting the expression "kinetic energy" for Rankine's phrase, "actual energy." Hence, today, we use the expression "kinetic energy" for the capacity of a body or system to perform mechanical work by reason of the fact that it is in motion, and the expression "potential energy" for its capacity to perform mechanical work by reason of its being in an elevated position, or in a state of stress. If these terms had been in use in the early part of the nineteenth century, much of the confusing language of the earlier writers could have been made clearer.

More than two centuries ago, Locke, the English philosopher, said that "Heat is a very brisk agitation of the insensible parts of the object, which produces in us that sensation from whence we denominate the object hot; so that what in our sensation is *heat*, in the object is nothing but *motion*." Francis Bacon had also previously expressed a similar thought in his *Novum Organum*. These speculations had no practical outcome, however, and they were merely stated by their originators, and were not developed in any manner. Daniel Bernoulli outlined the kinetic theory of gases in his treatise on hydrodynamics, published in 1738; but he did not treat of the nature of heat, which is more or less intimately connected with that theory. Lavoisier and Laplace, in their memoir on heat published in 1780, referred explicitly to the possibility that heat is due to molecular motions within the substance of the heated body; but they did not attempt to decide between this theory and the older caloric theory. Apparently it was Lavoisier who was responsible for the suggestion that heat might be merely a form of energy, for traces of this

idea are to be found in his treatise on chemistry, published in 1789. Moreover, Lavoisier was executed in 1794 (for political reasons), and in all that Laplace wrote in the years following this, he shows himself to be convinced of the correctness of the old, or "caloric" theory of heat.

The first really definite attempt to disprove the material nature of heat appears to have been made by Count Rumford in the military arsenal at Munich, Germany, in 1798. Interesting details concerning his experiments are given in the first chapter of Preston's *Theory of Heat*. He caused a blunt boring tool to revolve, under great pressure, against the bottom of a gun-metal cylinder, surrounded by a non-conducting covering of flannel; the cylinder being drilled with a small radial hole for the reception of a thermometer. When the apparatus had been in action for half an hour, the temperature of the metal cylinder had been raised from 60° Fahr. to 130° Fahr. The cylinder weighed 113 pounds, and the metallic dust removed by the boring tool was found to weigh only 837 grains, or less than two ounces. He calculated that the amount of heat produced would be sufficient to boil about five pounds of ice-cold water; and he was strongly of the opinion that such a quantity of heat could not be reasonably accounted for, either by supposing that it had been "rubbed out" of the metal, or by supposing that the quantity of "caloric" that was combined with the two ounces of metallic dust was less, by that amount, than the quantity that was originally combined with these same two ounces of metal, before they were removed from the cylinder by abrasion. Continuing his experiments, Rumford succeeded in boiling 2½ gallons of water (originally at 60° Fahr.), by the application of friction for two hours and a half. Rumford became satisfied, in his own mind, that heat is not a material thing; but, for reasons into which we cannot here enter, other philosophers did not regard his work as affording convincing proof of the falsity of the caloric theory.

In 1799 Davy succeeded in converting ice into water by rubbing two pieces of ice together. This really disposed of the objections that the calorists had raised against the experiments of Rumford; but the caloric theory had become so firmly rooted in scientific doctrine that Davy's experiments attracted but little attention, and Davy himself (then a young man of twenty) appears to have had less confidence in the new idea than Rumford had. In 1812, however, Davy, in his *Elements of Chemical Philosophy*, said that "The immediate cause of heat is motion, and the laws of its communication are precisely the same as the laws of the communication of motion." Of course the last part of this sentence is open to criticism; for if it is not incorrect, it is at all events hazy and indefinite. We shall not dwell further upon Davy's work, however, for while it doubtless influenced scientific thought, and bore fruit in later years, it had no immediate and obvious effect upon the progress of science, and his arguments "were even treated by some as wild and extravagant speculations."

It is said that one of the Montgolfier brothers (best known as the inventors of the balloon) favored the non-material theory of the nature of heat, about the beginning of the nineteenth century; but the writer has been unable to find where either one of them expressed such an opinion in print. A suggestion concerning the rôle played by Montgolfier is made below, however, in connection with the mention that is made of Séguin.

In 1824 Carnot published his *Reflections on the Motive Power of Heat* which was a most remarkable essay, and in which will be found, for the first

time, several conceptions that are of fundamental importance in modern science. As we have already said, Carnot still formally adhered to the materialistic theory of heat; but the extracts from his private papers that were subsequently published by his brother indicate that he was not entirely satisfied on this point, in his own mind. (See Thurston's translation of the *Reflections*, published by John Wiley & Sons, New York.) It is not unlikely that he would have established the true nature of heat, if he had lived a few years longer; but he died in 1832, at the age of thirty-six.

In 1837 Karl Friedrich Mohr, who is best known on account of his work in chemistry, wrote a short memoir (in German) entitled "On the Nature of Heat," in which he says: "Besides the known fifty-four chemical elements there exists in nature only one agent more, and this is called 'force' [i. e., 'energy,' according to the modern terminology]; it can under suitable conditions appear as motion, cohesion, electricity, light, heat, and magnetism." This memoir was sent to Poggendorff, for publication in the *Annalen der Physik*; but the manuscript was declined. A friend of Mohr then had it published, without Mohr's knowledge, in an obscure physical journal printed in Vienna (Baumgartner and von Holger's *Zeitschrift für Physik*, 1837, Vol. 5, page 419); and Mohr learned of its publication only at the end of 1864, after the lapse of twenty-seven years. Mohr had given an abstract of the paper, however, in Liebig's *Annalen der Pharmacie*, of which he was himself an editor. (See Vol. 24, 1837, page 141. Professor Tait published a translation of this abstract of Mohr's in the *Philosophical Magazine*, August, 1876, page 110.)

In 1839, Armand Séguin, in a work relating to the influence of railways ("Sur l'Influence des Chemins de Fer"), and dealing, in general, with the principles of political economy rather than with those of physics, raised the question of the nature of heat, and favored the view that heat is not a material substance, but merely a form of energy. Séguin's book is now quite rare; but Tyndall has reprinted the passages relating to the nature of heat, in the *Philosophical Magazine* for July, 1864, page 29. The fundamental ideas therein advanced were not original with Séguin, however (a fact which appears to be overlooked almost universally by those who refer to his writings), for he says, himself, that they were transmitted to him, a long time before, by his uncle, Montgolfier. (See *Comptes rendus*, 1847, Vol. 25, page 420.) As Montgolfier was a member of the French Academy of Sciences, and a man of education, it is not at all unlikely that he was familiar with Davy's treatise of 1812, to which reference has already been made, and also with Rumford's papers. We have no wish to do Montgolfier an injustice, but we feel that the possibility of this origin of the ideas commonly attributed to Séguin should be at least suggested.

To the names mentioned above, as forerunners of the modern theory of the nature of heat, many others might be added,—as, for example, Young, Oersted, Haldot, Morosi, Fresnel, Liebig, Grove, and Faraday. All of these men appear to have held ideas, of varying degrees of distinctness, that may be considered as foreshadowing the new theory of the relation of heat to mechanical energy. With the single apparent exception of Séguin, however, no writer that we have thus far mentioned made any attempt to state the definite numerical relation between heat and mechanical energy; nor did any even state in distinct terms a belief that an exact relation of this nature exists. Séguin, indeed, in his work already cited, gave a series of numbers which were at one

time held to constitute a valid estimate of the mechanical equivalent of heat. Tyndall, however, showed that Séguin's numbers cannot fairly be interpreted in that manner, and Joule and Tait both admitted, subsequently, that Séguin did not actually give a value of the mechanical equivalent. (See the *Philosophical Magazine* for 1864, July, page 20; August, page 150; and October, page 290.)

Many of the writers who treat of the early history of the mechanical equivalent fail to appreciate the fact that there had been a great deal of general speculation about the nature of heat, before either Mohr or Séguin had written a word on the subject. For example, the article on "Heat" in the *Encyclopedia Metropolitana* was probably written not later than 1835, and perhaps as early as 1830; and yet in its brief but very interesting sixth chapter the author (Rev. Francis Lunn) plainly shows that the scientific world was at that time divided as to the nature of heat. "Of the two principal theories," he says, "the one admits the materiality of heat; while the other, denying that it is a substance, considers it a property of matter, producing its effects by an actual vibration among the molecules of that matter." But the point to be observed is, that all of these speculations, up to the year 1842, had been more or less vague and hazy; and the real constructive period of the modern theory can hardly be said to have begun until the existence of the mechanical equivalent had at least been affirmed in the most unmistakable and unequivocal manner.

In May, 1842, an obscure German physician, Dr. Julius Robert Mayer, published, in Liebig's *Annalen der Pharmacie*, a short paper entitled "Remarks upon the Forces of Inanimate Nature," in which he distinctly states the equivalence between heat and mechanical energy, pronounces them to be mutually convertible in accordance with a perfectly definite law, and gives a numerical value of the mechanical equivalent of heat, as calculated by himself from what were probably the only experimental data then in existence from which such a value, having any pretension to accuracy, could be obtained by a logically defensible method. A rough value of the equivalent could have been obtained from Rumford's experimental data, as Joule showed in 1849 (Joule, *Scientific Papers*, Vol. 1, page 299); but in order to perform the calculations required, we have to simply guess at the quantity of mechanical work that was performed by the two horses that Rumford used to operate his apparatus. Mayer made no use of Rumford's experiments, and it is quite possible that he knew nothing about them, at the time his first paper was written. He chose, instead, data furnished by the experiments of Gay-Lussac and de la Roche and Bérard,—experiments that were made without the smallest reference to the new theory, and upon which no one would fix his attention, who was not thoroughly imbued with the fundamental principles of that theory. We do not need to discuss Mayer's work further in the present place, because the biographical article in our last issue covers the ground sufficiently.

The next contribution to the development of the modern theory consisted in a paper that was presented to the Royal Scientific Society of Copenhagen, in June, 1843, by the Danish civil engineer, A. Colding. As the more familiar works of reference are strangely silent with respect to this man, we may say that his full name was Ludvig August Colding, that he was born July 13, 1815, in Seeland, Denmark, and that he died March 22, 1888, at Copenhagen, in which city his life was mostly spent. His first paper was entitled "Theses Concerning Force," and in it he described the results of some 200 experiments made by

himself, upon the generation of heat by friction. It was favorably received by the society, which granted him a sum of money in order that he might carry his researches further. The results of the newer and more complete series were communicated to the Association of Natural Philosophers, at a meeting held in Copenhagen in 1847, and further papers by Colding, partly experimental and partly theoretical, were published in 1848, 1850, 1851, and 1856. His first paper, which is the only one of present interest, has never been translated, so far as we are aware, nor have we been able to obtain access to a copy in the original Danish. We are forced, therefore, to infer its general nature from the account that Colding has given of his own early work, in the *Philosophical Magazine* for January, 1864, page 56, under the title, "On the History of the Principle of the Conservation of Energy." So far as we can judge by this means, his original paper was markedly metaphysical (almost theological in places) in its nature, and the line of reasoning that he adopts is certainly not, in all respects, that which prevails in physics today. It is the experimental part, however, which is of special interest; and unfortunately we are unable to satisfy ourselves with respect to this, without seeing the original paper. Verdet and Helmholtz, in their discussion of the history of the mechanical equivalent, both place Colding next to Mayer, and before Joule, in the order of precedence as determined by publication; but the present writer is not sure that Colding really gave an actual determination of the mechanical equivalent, in his first paper. At all events, he does not make a definite statement to this effect, in his account of what he did. "If we look more nearly," he says, "at the figures given in my [first] treatise, which I only presented as a preliminary one, it will be seen that, independently of the materials by which the friction and the heat arose, an amount of mechanical work equal to 350 kilogram-meters should be able to raise the temperature of one kilogram of water 1° C." This corresponds, in English measure, to an equivalent of 638 foot-pounds per Fahrenheit degree; but it will be observed that Colding's language, here quoted, may be fairly construed to mean that no value of the equivalent was *actually given* in the original paper, but that his early measurements were *sufficient* to yield the value here quoted. We see no way of settling this point without examining the memoir itself. If some estimate of the equivalent (however imperfect) was not actually given in it, then Colding could hardly be considered as antedating Joule.

James Prescott Joule's first paper dealing with the convertibility of heat and mechanical energy was entitled "On the Calorific Effects of Magneto-Electricity, and on the Mechanical Value of Heat," and was read before one of the sections of the British Association at its meeting at Cork, on August 21, 1843. In this paper the theory that heat is a form of energy is distinctly enunciated, and while the various experimental results that are given are widely discrepant, the general conclusion is given that "The quantity of heat capable of increasing the temperature of a pound of water by one degree of Fahrenheit's scale is equal to, and may be converted into, a mechanical force capable of raising 838 pounds to the perpendicular height of one foot." Joule continued his experiments for the more accurate determination of the mechanical equivalent of heat, at intervals, for many years, and by various methods. In 1844 he obtained the value 823, in foot-pounds per Fahrenheit degree. In 1845 he published five new series of experiments, the mean of which gave 802

as the equivalent; and in June, 1847, he read a paper before the British Association, at Oxford, entitled "On the Mechanical Equivalent of Heat, as Determined by the Heat Evolved by the Friction of Fluids," in which the value concluded for the equivalent was 781.8. On June 21, 1849, he communicated to the British Association a more lengthy paper bearing the title, "On the Mechanical Equivalent of Heat," and it is here that we find the well-known value 772 given as the equivalent. In 1867, by an electrical method, he obtained the value 782.5, and the discordance between this and 772 led to a further and very careful investigation, by which Joule's final value, 772.55, was obtained in 1878. The exact value of the equivalent, according to the best modern measurements, cannot be stated intelligently without some discussion of the specific heat of water, and of the principles of thermometry; and hence this must be deferred to some future occasion, as we are here concerned merely with the earlier part of the history of the subject.

Following the early papers of Mayer, Colding and Joule, there were many contributions to the theory of heat, along the lines that these pioneer investigators had started. So far as the mechanical equivalent is concerned, these contributions consisted mainly in the re-determination of the equivalent by various methods, and in the verification of the doctrine of the conservation of energy from many points of view. In 1847 Helmholtz published his classical memoir entitled "On the Conservation of Energy" ("Ueber die Erhaltung der Kraft"), in which the modern theory of energy was developed, for the first time, as a complete science, and in all its generality. Ten years later, in 1857, Hirn gave a complete experimental verification of the conservation of energy, so far as it relates to the steam engine, by comparing the mechanical work performed by the engine with the quantity of heat delivered to it from the boiler, the quantity of heat rejected to the condenser, and the quantity lost by radiation; and for the numerical value of the mechanical equivalent, as obtained in this way by the direct study of the steam engine, he found the numbers 753 and 766, which must be admitted to be exceedingly good approximations to the results obtained by methods susceptible of greater accuracy.

The question as to whom the credit of the discovery of the mechanical equivalent of heat belongs has been discussed, acrimoniously and otherwise, upon many occasions, and by many men. In our biographical sketch of Mayer, published in the last issue of THE LOCOMOTIVE, we referred to the discussion between Joule and Mayer, in 1848-49. A much more extended controversy, confined chiefly to Tait and Tyndall, arose in 1862, as the outcome of Tyndall's lecture on "Force," delivered at the Royal Institution in that year. We cannot describe this controversy fairly, for want of space; but the interested reader will find most of it in the *Philosophical Magazine*. Some idea of the general spirit that pervaded it may be formed from the following passage from the article in which Tyndall replied to the first attack of Tait and Thomson (*Philosophical Magazine*, March, 1863, page 220): "Until the 20th of February," he says, "I was not aware of the existence of an article in the October number of a journal called *Good Words*, from the combined pens of the Professors of Natural Philosophy in Glasgow and Edinburgh,—Professor William Thomson and Professor Tait,—in which, though not mentioned by name, I am referred to in a manner which it might be expected would have come to my knowledge long ago. When, however, it is known that the other articles

in the number to which I refer bear such titles as 'The Childhood of Jesus,' 'The Trial Sermon,' 'The Bands of Love,' 'At Home in the Scriptures,' etc.. I think I may be excused if an article on Energy, in the scientific sense of the term, imbedded in such matter as those titles indicate, escaped my attention."

It appears to be reasonably clear that the idea of heat and mechanical energy being mutually convertible in a definite ratio, was a gradual growth, that it was grasped only indistinctly at first, and that it did not take the form of a definite and positive conviction until Mayer, Colding and Joule began the preparation of their first papers on the subject. Colding is usually omitted from serious consideration, in the attempt to assign the credit of the discovery, mainly because his papers were written in a language unfamiliar to the general mass of scientific students, and because they had but little influence upon the development of the modern theory of energy; but such a course can hardly be considered to be just.

As between Mayer and Joule, Tyndall's estimate appears to be eminently fair. "In reference to their comparative merits," he says, "I would say that as seer and generalizer, Mayer, in my opinion, stands first,—as experimental philosopher, Joule." The entire history of the subject is epitomized by Merz (*History of European Thought*, Vol. 2, page 137) as follows: "The first definite use of the new conceptions of power and of work, and of a scale of mechanical value, were contained in the writings of Poncelet and Sadi-Carnot, in France, during the first quarter of the century. The first philosophical generalizations were given by Mohr and Mayer; the first mathematical treatment was given by Helmholtz; the first satisfactory experimental verification by Joule, during the second quarter of the century. The practical elaboration of the whole system, following upon Joule's and Regnault's experiments, belongs, through Thomson and Rankine in this country [England], and through Clausius in Germany, to the third quarter of the century.

The Properties of Steam.

FIFTH PAPER.—EXACT DETERMINATIONS OF THE PRESSURE OF SATURATION.

We have now to consider two series of experiments that may fairly be placed in a class by themselves, on account of the extreme care with which they were made. In these two series the most minute attention has been paid every detail of the work, and an attempt has been made to secure rigid scientific accuracy, or to approach it as nearly as modern instrumental means will permit. Of course the measures that we are about to discuss cannot be truly "exact," but we have designated them by that term because it is a convenient one, even though it is not precise, to signify that they are presumably of a higher order of precision than any others that have yet been made. The two series in question are (1) a series by H. F. Wiebe, of the German Physikalisch-Technische Reichsanstalt, extending from 82° C. to 109° C. (189° to 212° Fahr.), and described in the *Zeitschrift für Instrumentenkunde*, Vol. 13, September, 1893, page 320, and (2) a series by M. Thiesen and K. Scheel, extending from -11° C. to +25° C. (12° to 77° Fahr.), and described in the same journal for June, 1901, Vol. 21, page 175, and more fully in the *Wissenschaftliche Abhandlungen* of the Reichsanstalt, Vol. 3, 1900, page 71. We understand that observations, intended to be of a similar order of accuracy, have been made by Chappuis;

but these have apparently not been published, and Wiebe, in the preface to his steam tables ("Tafeln über die Spannkraft des Wasserdampfes," Braunschweig, 1903), states that Chappuis has informed him in a personal letter that "they cannot yet be regarded as final, because they are probably affected by systematic errors."

We shall first take up Wiebe's experiments, in the execution of which he

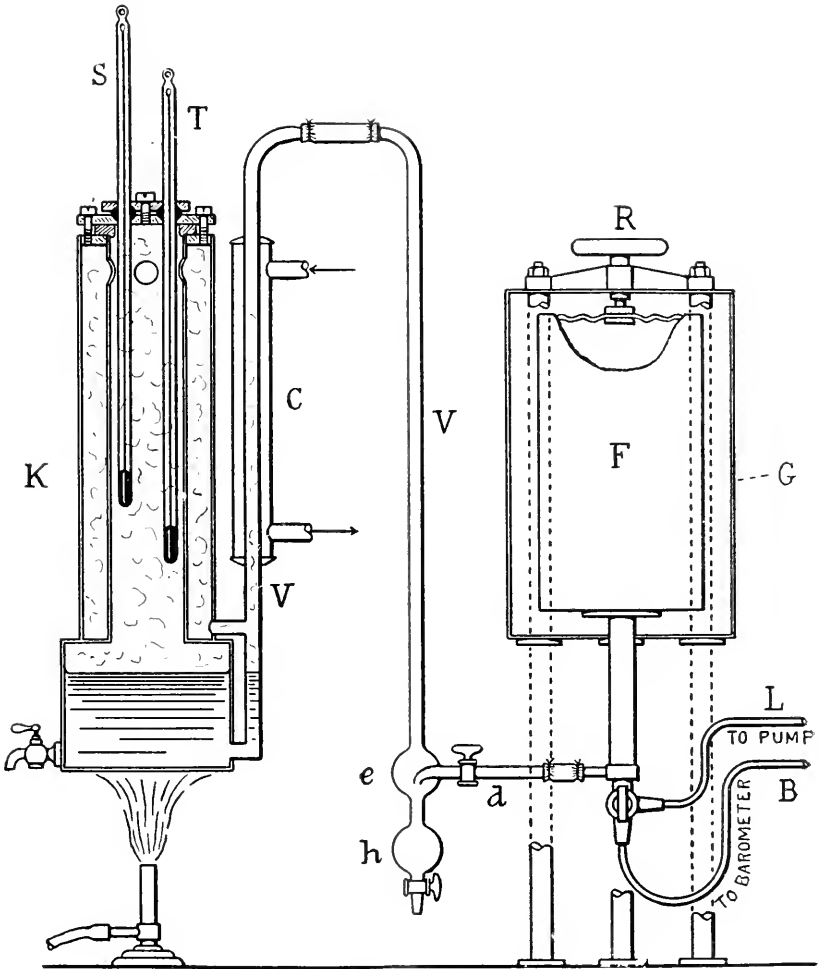

FIG. 1.—WIEBE'S APPARATUS.

was assisted by Fr. Grützmaier. Wiebe does not describe the apparatus that he employed, but we understand that it was substantially identical with that described by W. Pomplun in the *Zeitschrift für Instrumentenkunde* for January, 1891, Vol. 11, page 1, which had been constructed for the Reichsanstalt a short time previously, and with which Pomplun had already made some preliminary experiments. Wiebe may have made some minor changes in it, but as we find

no statement to this effect, the apparatus will be described in the form in which Pomplun used it.

It consisted essentially of two parts, (1) the steam-generating device, shown at *K* in Fig. 1, and (2) an air-reservoir, shown at *F* in the same illustration. The principle involved is identically the same as that underlying the apparatus of Regnault that is illustrated on page 92 of THE LOCOMOTIVE for July, 1906, and fully described in the same issue. The fundamental idea is, that the pressure upon the surface of the water in *K* can be adjusted at will, within reasonable limits, by compressing or rarefying the air in the reservoir *F*; and each experiment will then consist in determining, by means of the thermometers in *K*, the temperature at which water boils under the constant pressure that prevails in the reservoir *F*. To keep the temperature (and therefore the pressure) of the air in *F* as nearly constant as practicable, the reservoir *F* is surrounded by a vessel, *G*, that is filled with water; and when the apparatus is in action, the air reservoir is protected from radiation from the heated steam-generator by the interposition of a screen of asbestos. The pressure in the reservoir *F* is regulated approximately by pumping air into the reservoir, or out of it, through the tube *L*; and to obtain a more accurate adjustment of the pressure, the top of the reservoir is made in the form of a corrugated diaphragm, which can be moved in or out, within limits, by means of the adjusting screw *R*. The pressure in *F* being brought, by these means, approximately to some value that has been determined in advance, its *precise* value is measured by means of an accurate barometer, whose cistern communicates with the reservoir through the tube *B*.

When the water in *K* is caused to boil, the steam that is generated passes up around the thermometers *S* and *T* that are placed in the central cylinder, and then downward through the outer cylinder, to the tube *TT'*; the object of the outer cylinder being to jacket the inner one, and so prevent the possible loss of heat from the thermometers by radiation. A condenser, *C*, through which cold water is constantly flowing, surrounds the tube *T'*, so that the steam which enters *T'* becomes condensed, and flows back, in the form of water, into the lower part of *K*. The right-hand end of the tube *T'* terminates in a pair of bulbs, *e h*, the lower of which is intended to collect any water that may be distilled over, in spite of the condenser *C*. The upper one, *e*, receives the tube *d* that comes from the air-reservoir; the extremity of *d* being drawn out to a small diameter and pointed downward, to lessen the likelihood of any water finding its way into *F*. The cover of *K* is made of two circular plates, through which holes are drilled for the reception of the stems of the thermometers; these holes being conically enlarged on the sides of the plates that face each other, so that the opening through which each thermometer passes has the form, when the cover plates are in position, of a double cone, of the largest diameter of which comes between the plates. A similar double cone of soft rubber is placed upon the stem of each thermometer, so that when the upper plate is screwed down snugly, the joint around the thermometer stem is rendered steam-tight, so far as the pressures at which Wiebe worked are concerned.

The apparatus being arranged as shown, each experiment consisted in filling the reservoir *F* with air having the pre-determined pressure, and then boiling the water in *K*, and observing the temperatures recorded, under these conditions, by the thermometers *S* and *T*; the pressure within the reservoir *F* being

accurately determined, simultaneously with the reading of the thermometers, by means of the barometer that is connected with the tube *B*.

The two thermometers that were used were constructed of Jena glass, by R. Fuess, and the necessary corrections to be applied for their errors of caliber and of graduation, and for the inner and outer pressure, were determined with the greatest care. (In the experiments of Regnault, by this method, the thermometers were protected from the pressure of the steam by thin iron tubes; but as Wiebe's pressures did not exceed the pressure of the atmosphere in any case, he left the bulbs exposed directly to the steam, and eliminated the effects of variation of pressure by determining the "correction for outer pressure," as recorded above. This matter of pressure-corrections in accurate thermometry is explained in detail in Guillaume's *Thermometrie de Précision*.) The correction to be applied on account of the stems of the thermometers projecting out of the steam-generating apparatus was determined as exactly as possible by the aid of two little auxiliary thermometers, which were enclosed in glass tubes, and whose reservoirs extended from the lower surface of the cover of the apparatus to the upper extremity of the mercury threads in the main thermometers. The zero-points of the thermometers were also carefully determined, both before and after each series of observations, and precautions were taken to detect any distillation of mercury that might occur, within the thermometers, owing to the fact that their upper ends were cooler than their lower ends.

The barometer that was used was constructed with great care by R. Fuess, and its accuracy was carefully investigated before the experiments upon the pressure of the steam were begun. Four series of experiments were performed, in all, the results of which are given separately in Table I. In making the observations of each series, each observer made either two or four readings of each thermometer, and of the barometer; and these readings, either four or eight in number, were averaged together, and the result was regarded as a single observation. The pressure in the reservoir *F* was then changed, and an interval of at least fifteen minutes was allowed to elapse before the next observation was made, in order to afford time for the temperatures and pressures within the apparatus to become equalized under the new conditions. Of the four series of experiments, the first three were made with the pressures increasing,—that is, with each successive pressure in the reservoir *F* greater than the one immediately preceding it,—while the fourth was made with decreasing pressures.

Although mercury-in-glass thermometers were used in the actual work, their readings were all reduced to the scale of the air thermometer, by means of the corrections given in the *Zeitschrift für Instrumentenkunde*, 1890, page 246; so that the temperatures given in the table are expressed upon the scale of the "normal" air thermometer. The barometric heights, in terms of which the pressures are expressed, have also been reduced to the values they would have had if the experiments had been conducted at sea-level, in latitude 45°.

Wiebe makes no explicit statement as to the purity of the water with which his experiments were made, but it is doubtless safe to assume that proper precautions were taken in this respect, in view of the fact that his work was performed at the Reichsanstalt, where "water" means "water."

We give the temperatures as obtained from each of the two thermometers, in order that the order of accuracy of the thermometry may be evident; but

the average of the two, which is given under the heading "Mean Temperature," is to be taken as the temperature corresponding to the observed pressure given on the same horizontal line.

TABLE I.—PRESSURE AND TEMPERATURE OF SATURATED STEAM, AS OBSERVED BY WIEBE AND GRUETZMACHER.

OBSERVED TEMPERATURE (CENTIGRADE SCALE).			Observed Pressure. (Millimeters.)
By Thermometer No. 270	By Thermometer No. 341.	Mean Temperature.	
SERIES 1. July 3, 1893.			
82.162°	82.174°	82.168°	387.81
82.298	82.302	82.300	390.05
85.451	85.465	85.458	441.32
90.703	90.710	90.706	540.42
95.394	95.390	95.392	643.30
100.054	100.042	100.048	761.33
SERIES 2. July 6, 1893.			
82.164°	82.172°	82.168°	387.86
82.236	82.224	82.230	388.80
84.085	84.087	84.086	418.52
84.112	84.104	84.108	418.85
86.108	86.095	86.103	452.82
86.120	86.106	86.113	453.00
90.096	90.080	90.088	527.83
95.225	95.218	95.222	639.32
100.032	100.024	100.028	760.74
SERIES 3. July 7, 1893.			
82.170°	82.177°	82.174°	388.00
85.150	85.157	85.154	436.48
90.076	90.066	90.071	527.56
95.132	95.122	95.127	637.23
100.025	100.016	100.021	760.68
SERIES 4. July 7, 1893.			
100.018°	100.000°	100.009°	760.16
95.069	95.048	95.059	635.65
90.108	90.100	90.104	528.17
85.070	85.085	85.078	435.04
82.040	82.045	82.044	385.87

We pass, now, to the consideration of the experiments made by Thiesen and Scheel. These were executed with as much care as Wiebe's, but as they were limited to pressures which in no case exceeded the pressure due to a column of mercury one inch in height, they were carried out with a very different form of apparatus, which is shown, diagrammatically, in Fig. 2.

In this illustration *G* and *H* are a pair of glass bulbs, each about two inches in diameter; *G* containing the water whose vapor is to be studied, while *H* is partially filled with phosphorus pentoxide, which is a solid substance, not at all volatile at ordinary temperatures, but possessing a power-

ful affinity for the vapor of water. By means of an arrangement of glass tubing, which is shown in the diagram, and the purpose of which will be explained presently, the bulbs *G* and *H* are respectively connected with the two sides of a pressure gage *P*, which merits special description.

The gage *P* is rectangular in its general external form, and is divided into two equal chambers by a vertical partition, which is open at the bottom, as shown. Mercury is introduced into the gage as suggested at *M* and *N*, and to ascertain the difference in pressure between the two chambers we have only to observe the difference of level between the two mercury surfaces. It will be seen, therefore, that the gage employed by Thiesen and Scheel is in no wise different, in principle, from any other mercury gage. Its real dis-

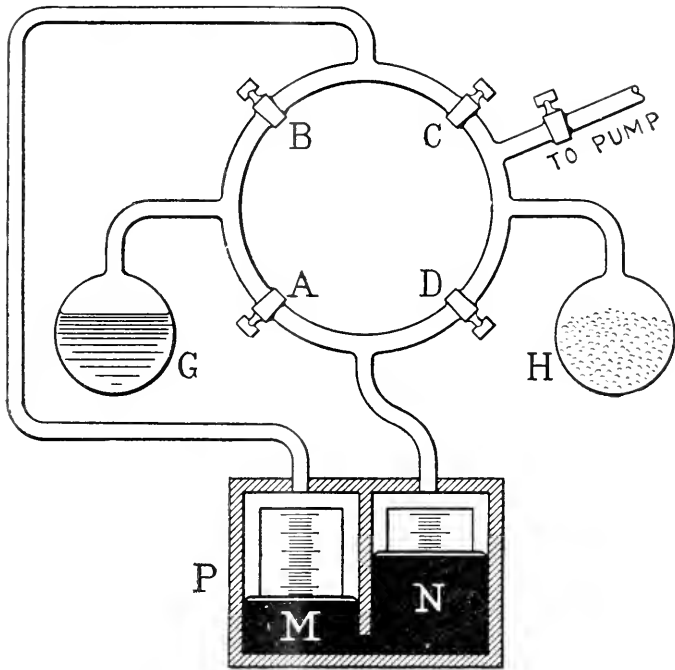

FIG. 2.—DIAGRAM OF THIESEN AND SCHEEL'S APPARATUS.

tinguishing feature is the means that are employed to measure the difference of level between *M* and *N* with a high degree of precision. For this purpose the front and back of each of the chambers is provided with a plate glass window, through which the interior of the gage can be observed. The back window in each chamber is accurately graduated, as suggested in Fig. 2, the graduation marks being horizontal, and spaced at a uniform interval of half a millimeter (one-fiftieth of an inch). The chambers were made of large diameter in order that the surface of the mercury might be sensibly flat, the curvature due to capillary action being practically confined to a narrow region around the walls of the chambers. The height of the mercury could be

estimated very closely by merely looking along the level surface, and noting, with the unaided eye, the position of this surface with reference to the graduation marks; but Thiesen and Scheel provided a far more delicate and accurate means of accomplishing this purpose. Each chamber was provided with a microscope, by means of which the mercury surface could be viewed horizontally, and in such a manner that the graduation marks and their images as reflected from the mercury surface could both be seen simultaneously, in the same field of view. Each microscope was provided with a micrometer eyepiece, by which the apparent distance between any given graduation mark and its reflected image could be accurately measured; and the actual level of the mercury surface was assumed to be half way between the mark and its image. In this way the level of the mercury in either chamber was determined with extreme precision, the measurements being carried out to the ten-thousandth part of a millimeter (the 250,000th part of an inch), although no claim is made that the results are actually correct to this order of refinement; and in quoting the experimental results that are given in Table 2, we have preserved only three places of decimals.

The arrangement of the tubing by which the bulbs *G* and *H* are connected with the mercury gage, *P*, is shown in Fig. 2. It consists of a closed ring of glass tubing from which branch tubes pass away, two of these leading to the respective bulbs *G* and *H* and two to the respective chambers of the pressure gage *P*, in the manner indicated in the diagram. By means of a fifth tube, the air is removed from the interior of the apparatus, before beginning the experiments, as perfectly as this can be done by means of a Töpler mercurial air pump. The circular tube is fitted with four valves, *A*, *B*, *C*, *D*, which are arranged alternately with the branch tubes that lead to the bulbs and the pressure gage, as shown; and a similar valve is provided in the tube that leads to the air pump. For the sake of simplicity in the illustration, these valves are all represented as though they were simple stop-cocks; but as a matter of fact they had the form indicated in Figs. 3 and 4, a valve of this character being known as a "barometric seal," or "mercury seal." The construction hardly needs explanation. The tube to be sealed is bent down, locally, into a *U*-shaped form, and from the bottom of the *U* a vertical tube extends downward to a distance of something more than thirty inches, its open lower end entering a larger tube, which serves as a sort of reservoir. Mercury is introduced as indicated in Figs. 3 and 4, and it is easy to see that if the vacuum in the *U* is perfect, the mercury in the small vertical tube (or in the *U* itself, as the case may be) will stand about thirty inches higher than that in the reservoir tube, on account of the pressure of the atmosphere upon the mercury in the latter. By raising the reservoir tube into the position shown in Fig. 3, the mercury will be caused to flow up into the *U*, thus effectually sealing it; while by lowering the reservoir tube, the mercury will be caused to leave the *U* entirely, thus bringing its two branches into free communication with each other, as shown in Fig. 4.

The apparatus being freed from air by means of the Töpler air pump, and the pump being then permanently sealed off from the rest of the apparatus by closing the mercury valve in the tube leading to it, the valves *A* and *C* are opened, while *B* and *D* remain closed. This puts the bulb *G* in free communication with the chamber *N* of the pressure gage, and the bulb *H* in similar communication with the chamber *M*. The chamber *N* and the upper part of

the bulb *G* will then be filled with water vapor having (so long as the pressure gage is not colder than the bulb *G*) the pressure that is due to the temperature of the water in *G*; while in the bulb *H* and the chamber *M* the pressure will be practically zero, since the phosphorus pentoxide in *H* will absorb any water vapor that may have existed in either *H* or *M*, or in the tube joining them. The exceedingly small amount of air that was not removed from the apparatus by the air pump will affect the pressure in both chambers of the pressure gage equally (or nearly so), so that the pressure as read from the gage will be the true pressure of the water vapor, corresponding to the temperature of the water in the bulb *G*.

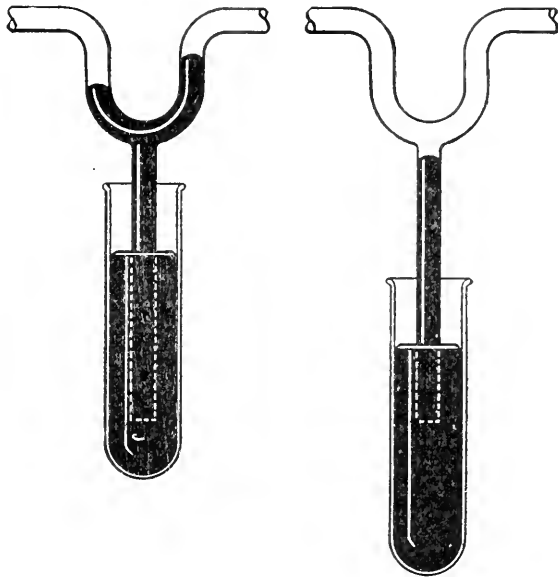

FIGS. 3 AND 4.—ILLUSTRATING THE "BAROMETRIC SEAL."

To guard against any constant error due to imperfect adjustment of the microscopes by which the gage is read, or to any other cause by reason of which perfect symmetry of action of the two sides of the gage might fail to be realized, the experiment is next repeated under precisely similar conditions, but with the valves *B* and *D* opened, and the valves *A* and *C* closed. This throws *G* into communication with *M*, and *H* into communication with *N*. The pressure as obtained with the valves arranged in this way is then averaged with that obtained under the first arrangement, and the result is assumed to be free from the effects of any error by reason of which either side of the gage might tend to give readings that are constantly too great or too small.

In the experiments that were made at the freezing point of water (namely, at 0° C.) the water bulb, *G*, was enclosed in a vessel some ten inches in diameter and twelve inches high, and chilled for some hours before any readings were taken, with a mixture of finely divided ice and distilled water; and at the termination of the experiments the purity of the ice that was used

was verified by examining the water into which it had melted. In the experiments that were made at temperatures above the freezing point, the vessel surrounding the bulb *G* was filled with water that was constantly stirred in order that its temperature might be kept uniform throughout, and the temperature was accurately determined by means of two high grade thermometers of Jena glass, whose corrections were determined with all the care already described in connection with Wiebe's work. The temperatures as given by Thiesen and Scheel, however, have been reduced to the scale of the *hydrogen* thermometer (instead of to that of the *air* thermometer, as in Wiebe's results).

It is well known that water can be cooled somewhat below the normal freezing point, without the occurrence of congelation, if it be kept perfectly quiescent. Thiesen and Scheel attempted to determine the pressure of the saturated vapor given off by such supercooled water, at about -6.5° C. and -11.3° C.: the bulb *G* being then surrounded by brine that was cooled by the agency of a freezing mixture.

The experimental result for the temperature 0° must be regarded as far more exact than that for any of the other temperatures, not only because the determination is intrinsically easier for this temperature, but also because the observers devoted far more time and attention to it. In fact, the result that is given for 0° was determined with so much care that it cannot be regarded as subject to correction, except as the result of some more careful series of experiments that may be executed in the future.

In conclusion we may say that Thiesen and Scheel satisfied themselves that the absorption of water vapor by phosphorus pentoxide is practically complete, even in a vacuum otherwise nearly perfect, by comparing, with this same apparatus, the vapor pressures of two moist samples of the pentoxide, one being at 0° C. and the other at 30° C. If the absorption of vapor were sensibly imperfect, a considerable difference of pressure might have been expected; but it was found that the pressure on the side of the warm bulb was only 0.0003 millimeter greater than on the side of the cool one. Moreover, a part of this difference was apparently due to other causes; and hence the conclusion appears safe, that the absorption by the pentoxide was practically perfect.

TABLE 2.—PRESSURE AND TEMPERATURE OF SATURATED STEAM, AS OBSERVED BY THIESEN AND SCHEEL.

Observed Temperature. (Centigrade.)	Observed Pressure. (Millimeters)	Observed Temperature. (Centigrade.)	Observed Pressure. (Millimeters.)
-11.334°	1.922	16.360°	13.919
-6.561^{\ast}	2.673 [∗]	19.840	17.362
0.000	4.579	19.844	17.341
+14.568	12.438	24.975	23.682
15.059	12.828	25.475	24.331

*Water in the bulb frozen.

Hartford Steam Boiler Inspection and Insurance Company.

ABSTRACT OF STATEMENT, JANUARY 1, 1907.

Capital Stock, \$500,000.00.

ASSETS.

	Par Value.	Market Value
Cash in office and in Bank,		\$143,952.21
Premiums in course of collection (since Oct. 1, 1906),		173,449.47
Interest accrued on Mortgage Loans,		26,448.03
Loaned on Bond and Mortgage,		1,047,720.00
Real Estate,		9,450.00
State of Massachusetts Bonds,	\$100,000.00	92,000.00
County, City, and Town Bonds,	326,000.00	340,330.00
Board of Education and School District Bonds,	34,000.00	35,800.00
Drainage and Irrigation Bonds,	3,000.00	3,000.00
Railroad Bonds,	1,439,000.00	1,582,090.00
Street Railway Bonds,	62,000.00	62,250.00
Miscellaneous Bonds,	87,500.00	87,665.00
National Bank Stocks,	41,800.00	60,970.00
Railroad Stocks,	194,200.00	259,201.00
Miscellaneous Stocks,	65,500.00	53,920.00

\$2,353,000.00

Total Assets, \$3,978,245.71

LIABILITIES.

Re-insurance Reserve,		\$1,931,847.29
Commissions and brokerage,		34,680.89
Losses unadjusted,		26,250.80
Surplus,	\$1,485,457.73	
Capital Stock,	500,000.00	

Surplus as regards Policy-holders, \$1,985,457.73

Total Liabilities, \$3,978,245.71

On December 31, 1906, the HARTFORD STEAM BOILER INSPECTION AND INSURANCE COMPANY had 95,310 steam boilers under insurance.

L. B. BRAINERD, Pres. and Treas. FRANCIS B. ALLEN, Vice-President.

J. B. PIERCE, Secretary. C. S. BLAKE, 2d Vice-President.

L. F. MIDDLEBROOK, Assistant Secretary.

E. J. MURPHY, M. E., Consulting Engineer.

F. M. FITCH, Auditor.

BOARD OF DIRECTORS.

FRANK W. CHENEY, Treas. Cheney

Brothers Silk Manufacturing Co.

CHARLES M. BEACH, of Beach & Co.

GEORGE BURNHAM, Baldwin Locomotive

Works, Philadelphia.

PHILIP CORBIN, P. & F. Corbin, New

Britain, Ct.

GEORGE A. FAIRFIELD, Ex-Prest.

Hartford Machine Screw Co.

J. B. PIERCE, Secretary Hartford Steam

Boiler Inspection and Insurance Co.

ATWOOD COLLINS, Prest. Security

Co., Hartford, Conn.

LUCIUS F. ROBINSON, Attorney,

Hartford, Conn.

JOHN O. ENDERS, U. S. Bank, Hart-

ford, Conn.

LYMAN B. BRAINERD, President and

Treasurer, Hartford Steam Boiler In-

spection and Insurance Co.

MORGAN B. BRAINARD, Treasurer

Aetna Life Insurance Co.

F. B. ALLEN, Vice-Prest., Hartford Steam

Boiler Inspection and Insurance Co.

CHARLES P. COOLEY, Vice Prest., Fi-

delity Trust Company, Hartford, Conn.

ARTHUR L. SHIPMAN, Corporation

Counsel, Hartford, Conn.

GEORGE C. KIMBALL, President Smyth

Manufacturing Co., Hartford, Conn.

Carnegie Library,
Pittsburgh, Pa.



Incorporated
1866.

Charter Per-
petual.

The Hartford Steam Boiler Inspection and Insurance Company

ISSUES POLICIES OF INSURANCE COVERING

ALL LOSS OF PROPERTY

AS WELL AS DAMAGE RESULTING FROM

**LOSS OF LIFE AND PERSONAL INJURIES DUE TO STEAM
BOILER EXPLOSIONS.**

*Full information concerning the Company's Operations can be obtained at
any of its Agencies.*

Department.	Representatives.	Offices.
NEW YORK, . . .	C. C. GARDINER, JR., Manager, R. K. McMURRAY, Chief Inspector,	New York City, N. Y., 100 William St.
NORTHEASTERN, . . .	C. E. ROBERTS, Manager, F. S. ALLEN, Chief Inspector,	Boston, Mass., 101 Milk St. Providence, R. I., 29 Weybosset St.
PENNSYLVANIA, . . .	CORBIN & GOODRICH, Gen. Agents, WM. J. FARRAN, Chief Inspector,	Philadelphia, Pa., 432 Walnut St.
MARYLAND, . . .	LAWFORD & MCKIM, Gen. Agents, R. E. MUNRO, Chief Inspector,	Baltimore, Md., 13-14-15 Abell Bldg. Washington, D. C., 511 Eleventh St., N. W.
SOUTHEASTERN, . . .	W. S. HASTIE & SON, Gen. Agts., W. M. FRANCIS, Chief Inspector,	Charleston, S. C., 44 Broad St.
SOUTHERN, . . .	LOUIS V. CLARK & Co., Gen. Agents, H. E. STRINGFELLOW, Chief Inspector,	Birmingham, Ala., 214-216 N. 20th St.
GULF, . . .	PETER F. PESCU, General Agent, R. T. BURWELL, Chief Inspector,	New Orleans, La., 818 Gravier St.
HOME, . . .	E. H. WARNER, General Agent, H. C. LONG, Special Agent, F. H. WILLIAMS, JR., Special Agent, F. S. ALLEN, Chief Inspector,	Hartford, Conn., 650 Main St.
SOUTHERN CONN.,	W. G. LINEBURGH & SON, Gen. Agts.,	Bridgeport, Conn., 1 Sanford Building.
PITTSBURG, . . .	JAMES W. ARROTT, LTD., Gen. Agt., BENJAMIN FORD, Chief Inspector,	Pittsburg, Pa., 401 Wood Street.
NORTHERN OHIO,	C. A. BURWELL, General Agent, H. A. BAUMHART, Chief Inspector,	Cleveland, Ohio, 337 Superior Av., N. W.
NORTHWESTERN,	H. M. LEMON, Manager, JAMES L. FOORD, Chief Inspector,	Chicago, Ill., 169 Jackson St.
SOUTHWESTERN,	V. HUGO, Manager, V. HUGO, Chief Inspector,	St. Louis, Mo., 319 North Fourth St.
WESTERN, . . .	THOS. E. SHEARS, General Agent, THOS. E. SHEARS, Chief Inspector,	Denver, Col., Room 2, Jacobson Bldg.
PACIFIC COAST, . . .	H. R. MANN & Co., General Agents, J. B. WARNER, Chief Inspector,	San Francisco, Cal., Merchants' Ex. Bldg.

17 Ar 40

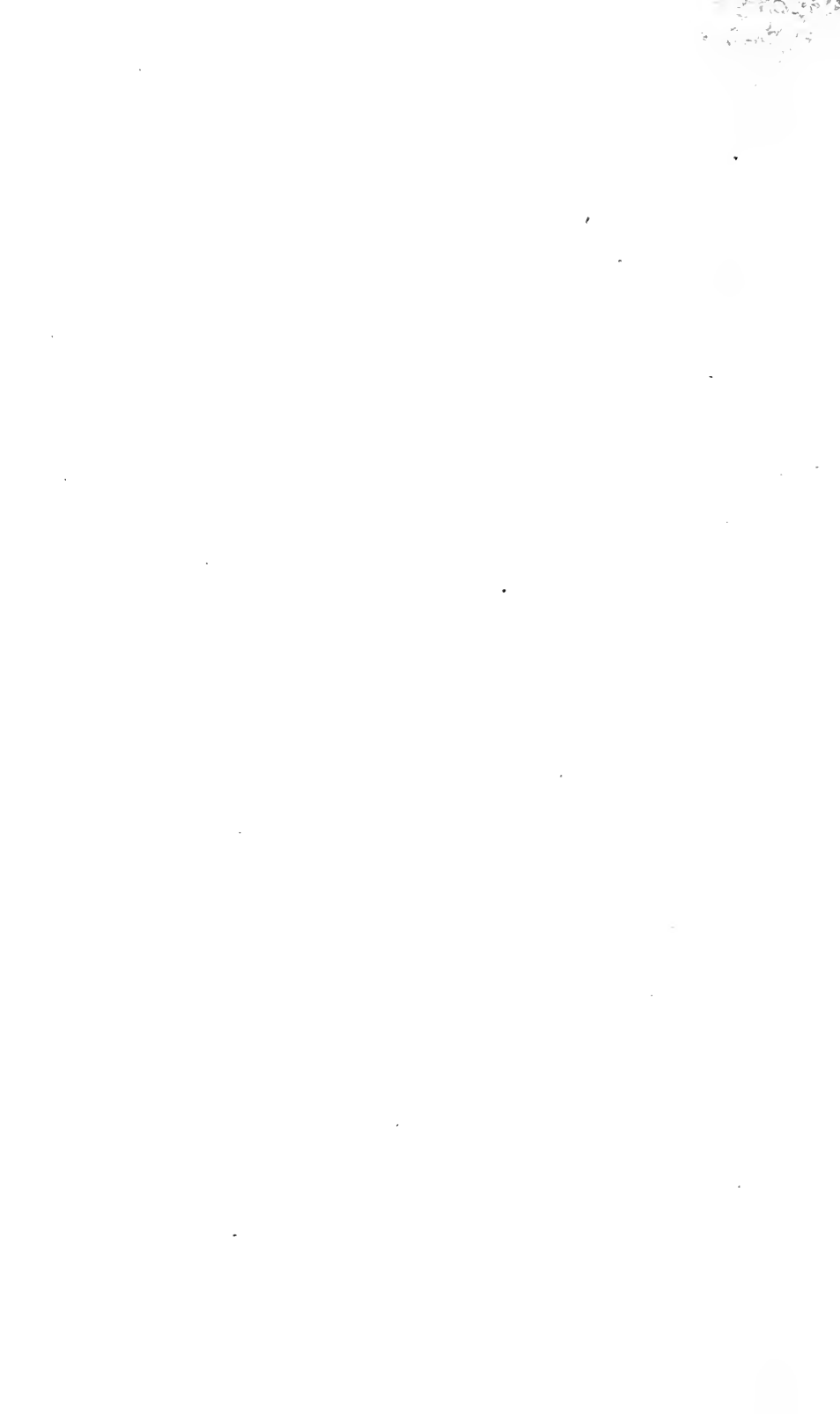

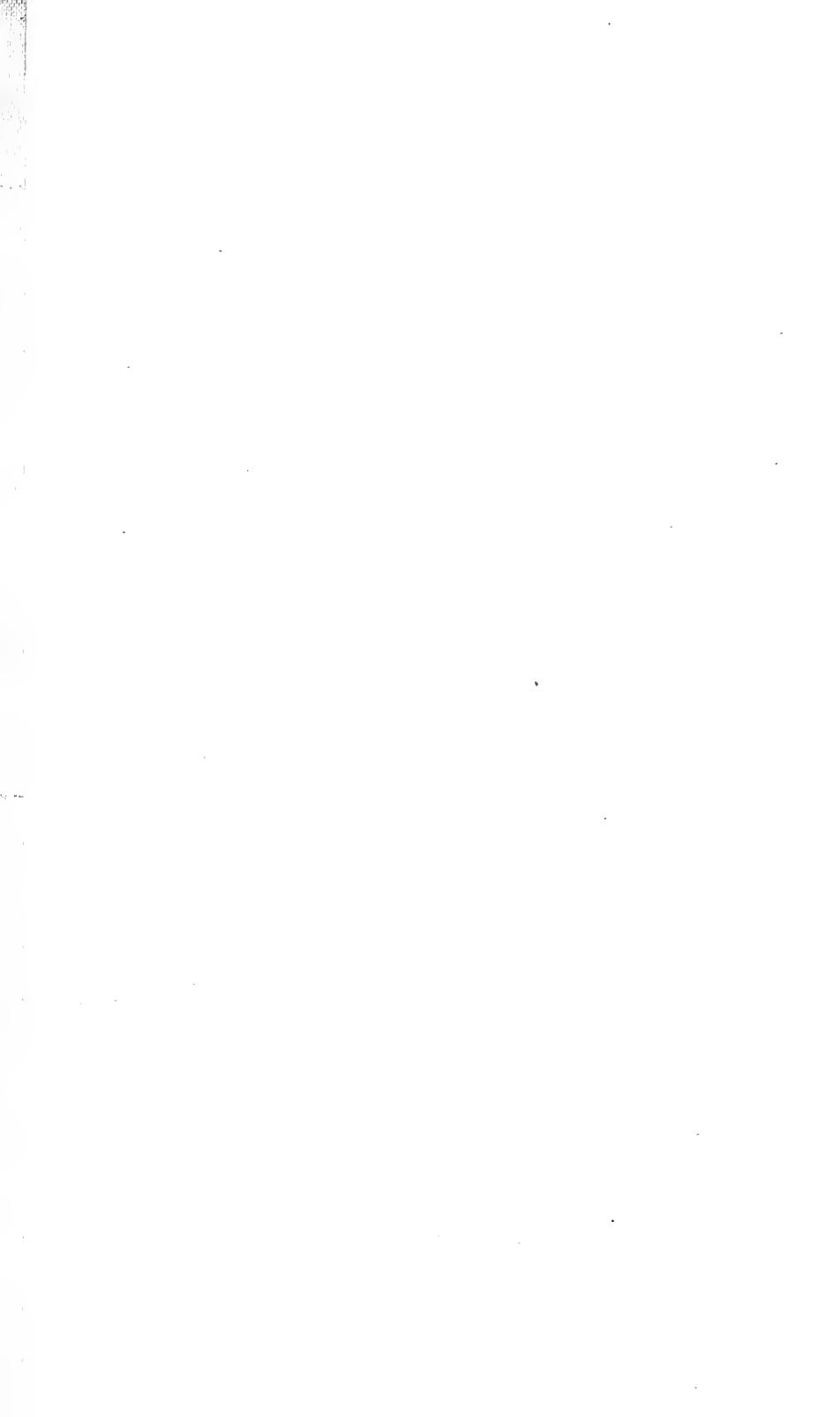

CARNEGIE LIBRARY OF PITTSBURGH



3 1812 04248 1300