



This is a digital copy of a book that was preserved for generations on library shelves before it was carefully scanned by Google as part of a project to make the world's books discoverable online.

It has survived long enough for the copyright to expire and the book to enter the public domain. A public domain book is one that was never subject to copyright or whose legal copyright term has expired. Whether a book is in the public domain may vary country to country. Public domain books are our gateways to the past, representing a wealth of history, culture and knowledge that's often difficult to discover.

Marks, notations and other marginalia present in the original volume will appear in this file - a reminder of this book's long journey from the publisher to a library and finally to you.

Usage guidelines

Google is proud to partner with libraries to digitize public domain materials and make them widely accessible. Public domain books belong to the public and we are merely their custodians. Nevertheless, this work is expensive, so in order to keep providing this resource, we have taken steps to prevent abuse by commercial parties, including placing technical restrictions on automated querying.

We also ask that you:

- + *Make non-commercial use of the files* We designed Google Book Search for use by individuals, and we request that you use these files for personal, non-commercial purposes.
- + *Refrain from automated querying* Do not send automated queries of any sort to Google's system: If you are conducting research on machine translation, optical character recognition or other areas where access to a large amount of text is helpful, please contact us. We encourage the use of public domain materials for these purposes and may be able to help.
- + *Maintain attribution* The Google "watermark" you see on each file is essential for informing people about this project and helping them find additional materials through Google Book Search. Please do not remove it.
- + *Keep it legal* Whatever your use, remember that you are responsible for ensuring that what you are doing is legal. Do not assume that just because we believe a book is in the public domain for users in the United States, that the work is also in the public domain for users in other countries. Whether a book is still in copyright varies from country to country, and we can't offer guidance on whether any specific use of any specific book is allowed. Please do not assume that a book's appearance in Google Book Search means it can be used in any manner anywhere in the world. Copyright infringement liability can be quite severe.

About Google Book Search

Google's mission is to organize the world's information and to make it universally accessible and useful. Google Book Search helps readers discover the world's books while helping authors and publishers reach new audiences. You can search through the full text of this book on the web at <http://books.google.com/>

Practical Photography: How to make lantern slides

Frank Roy Fraprie

Library
of the
University of Wisconsin

**TRANSFERRED TO
MEMORIAL LIBRARY**

Practical Photography No. 7

**HOW TO MAKE
LANTERN SLIDES**

Edited by

FRANK R. FRAPRIE, S.M., F.R.P.S.

Editor of American Photography

**American Photographic Publishing Co.
Boston, Mass.**

Copyright, 1918
by
AMERICAN PHOTOGRAPHIC PUBLISHING CO.

BEVERLY PRINTING CO.
BEVERLY, MASS.

301441

MAR -6 1926

WR

.9P88

$\frac{2}{7}$

How To Make Lantern Slides

What is a Lantern Slide?— In a *negative* we have the tones reversed, so that a white dress is black and a black object or a deep shadow is white. When we make our print from this, the tones are reversed again, this second reversal bringing them right. Such a print is a *positive*. We examine a print by *reflected* light, that is, the light falls on to the surface of the print and is thrown back or bent back. But if we make a print on glass, using for the purpose a dry plate, we still have a positive, but one which we must examine by looking *through* instead of *at*. Such a positive, because we can see through it, is often called a *transparency*. We examine it by transmitted light. Transparency, then, is a generic term for a positive picture on glass, or celluloid, or other transparent support. The support may even be of ground or opal glass, or the emulsion may have something added to it to give an opalescent or ground-glass effect, in which case it ceases to be transparent in the strict sense of the word, and is merely translucent, but it is still termed a transparency. Sometimes the expression "glass-positive" is used.

Such transparencies have various uses. They may be employed for window decoration, for lamp shades, for advertising purposes, and so on. They may be used for reproducing the original negative the same size, or larger or smaller. They may be made in small size

4 HOW TO MAKE LANTERN SLIDES

and put into the magic lantern and projected on to a white screen, in which case they are called lantern slides. The character of the transparency varies according to the purpose to which it is to be put. To be viewed in the window, and especially if of good size, it may be rich and strong, the highlights just removed from clear glass. For reproduction work, every part must show gradation, which means no clear glass and that the shadows must not be too strong, but the whole delicate and soft. For lantern slides, the highest lights may be clear glass, and the strength of the shadows and general vigor of the slide must depend on the light to be used for projection and the size of the projected image. Thus, the more powerful the light used in the lantern, the stronger may be the slide; and the larger the projected image, *i.e.*, the picture on the screen, the softer must be the slide. Obviously, if the slides are too strong for a given light and size of picture, it may sometimes be possible to effect an improvement by working to a smaller scale of projection, that is, a smaller picture on the screen. The beginner, however, will be well advised to get one or two really good slides from some firm supplying them, or from some first-class slide-maker, and to keep these as a guide in early experiments. Let us say, however, that the best test of a slide is to place a sheet of white blotting paper in a good light for writing and to hold the slide so that light from the blotting paper is thrown through the slide. In other words, look at the blotting paper through the slide. The slide should be sparkling and the shadows should show richness without any tendency to look clogged. If the slide is laid down film side against the blotting paper, the highlights should

show absolutely no *tint*. Another and perhaps better test for perfect clearness of highlights is to stand facing the window and hold the slide up so that one looks through it but at the dark shadow below the window-sill, not at the light. The image is illuminated, and most of it will appear grayish in tone, but if the highlights are perfectly clear glass, the shadow will be seen through them and they will appear black. This is the "dark ground" test.

It will be understood that this is the technically perfect slide. The pictorial worker may not want clear glass lights or rich deep shadows. The pianoforte gives a full gamut of tones — eight octaves — but many exquisite pieces of music may be played using only a fraction of these tones.

The size of the lantern slide (and therefore of the lantern plate) is $3\frac{1}{4} \times 4$ inches; the British size is $3\frac{1}{4} \times 3\frac{1}{4}$ inches, and it is well to remember this in the event of arranging exchanges of slides or the purchase of sets of British slides. The British size may be shown if a special carrier is used in the lantern, and this is inexpensive.

The Utility of Slides.— Slides are useful to the lecturer, teacher, and to the entertainer, for they enable a picture to be shown to a great number of people simultaneously. Slides prepared for the purpose may be used for advertising for the same reason, and often are so used, the image being projected on a screen set up in some suitable place — an empty shop-window, the side of a building, or the front curtain of a theatre. From this it follows that slides may be copies of printed matter, copies of diagrams, either white lines on black ground or black lines on white ground, copies of pictures

6 HOW TO MAKE LANTERN SLIDES

of all kinds, or made from direct original negatives of any kind of subject.

Although the production of a really fine slide — fine in subject, in gradation, strength, and color, in freedom from small mechanical defects, and so on — demands great skill and care at every stage of the work, slides for ordinary lecturing, teaching, and commercial purposes may be made by any careful worker with a little trouble and after a few preliminary experiments.

Where One Begins.— The starting point of the really fine slide is the negative from which it is made, and this is so to a much greater extent than in the case of a print, whether contact or enlarged. The clever manipulator may touch out defects, or scrape and pencil out objects in his negative and make good on his print, and practically defy detection of the work. Not so in the slide, where every touch is magnified possibly sixty or eighty times. If, therefore, one is preparing negatives with a view to making lantern slides of them, certain precautions are essential. A brand of plate should be chosen for its freedom from small mechanical defects. The camera and plate-holders, or changing-box must be kept scrupulously clean and free from dust. The developing and fixing solutions should be filtered, and, if possible, the plates fixed vertically in a grooved porcelain tank. Drying should be done in a dust-free atmosphere and at an even speed to prevent "drying marks." Any pinholes or spots which occur in spite of these precautions should be touched out by an expert spotter or retoucher by the aid of a magnifying glass. "These are the trifles that make for perfection, and perfection is no trifle," as the famous sculptor remarked. In a word, we want a *perfect negative* for super-excellent

slide-making; perfect in contrast, in gradation, and in freedom from blemishes. We can obtain good slides from average every-day negatives, but the super-excellent slide demands that little bit extra. Also, the greater the defining power of the lens, the better the image projected from the completed slide.

Methods of Slide Making.—From negatives or portions of negatives of suitable size, slides may be printed by contact; that is, the lantern plate is laid on the negative just as one lays down a sheet of bromide or gaslight paper, and the exposure is made in the usual way. This is the simplest method and it yields good results. Another method is to copy the negative in the copying camera, that is, to set up the negative so that it may be seen by transmitted light and photograph it, using a lantern plate and obtaining a positive. A third method is to use the enlarging lantern, though the principle is the same as when working with the camera. All three methods will be dealt with in turn. Which-ever method is employed, the development of the plates, fixation, and subsequent processes remain identical. We shall, therefore, give at the moment only two developers, one amidol and the other hydrochinon, so that the novice will not be confused. Either of these formulas will give a good black color on most of the plates obtainable.

AMIDOL DEVELOPER (ONE-SOLUTION)

| | |
|---------------------------------|------------|
| Amidol | 20 grains |
| Sodium sulphite (dry) | 120 grains |
| Potassium bromide | 10 grains |
| Water to | 10 ounces |

The sulphite should be dissolved first in, say, 6 ounces of water, then add the amidol and the bromide and bring the total bulk up to 10 ounces.

8 HOW TO MAKE LANTERN SLIDES

HYDROCHINON DEVELOPER (TWO-SOLUTION)

| | | |
|----|--|-----------|
| A. | Hydrochinon | 40 grains |
| | Potassium bromide | 60 grains |
| | Potassium metabisulphite | 40 grains |
| | Water to | 10 ounces |
| B. | Caustic potassium (or caustic soda), sticks | 80 grains |
| | Water to | 10 ounces |

For use, take equal parts of A and B.

The fixing bath may be made up with the addition of sodium metabisulphite or of sodium bisulphite, whichever is preferred.

FIXING BATH

| | |
|-------------------------------|---------------------|
| Sodium hyposulphite | 2 ounces |
| Sodium bisulphite | $\frac{1}{2}$ ounce |
| Water to | 10 ounces |

or

| | |
|------------------------------------|-----------|
| Sodium hyposulphite | 16 ounces |
| Water | 64 ounces |
| Dissolve and add | |
| Potassium metabisulphite | 1 ounce |
| Water | 16 ounces |

In a general way it is better to use the formulas given with the plates in use, but the above formulas work well with most plates, and we give the alternative in each instance in case the other reagent is not available.

A very clean porcelain dish is best for development, preferably large enough to take two plates side by side. Unless a grooved tank is used for fixing, a porcelain dish large enough to hold six or eight plates should be employed. Too small a dish causes loss of time when a batch of slides is being run off, and there is danger of hurrying fixation, which is fatal if after-processes are required, such as intensifying, reducing, or toning.

Printing, *i.e.*, the exposing of the lantern plate be-

hind the negative, is most conveniently done in an ordinary printing frame. In those cases where the slide is being made from a portion of a larger negative, say 5 x 7, it is wise to place a sheet of glass in the frame to support the negative and take the strain of the fairly firm pressure which is necessary to give good contact. This extra thickness, together with a felt pressure pad, renders it necessary to have a rather deep frame, and the point should be borne in mind when making a selection.

Almost any artificial light may be used. A weak light such as is given by a candle is not suitable to the gaslight type of lantern plate. Speaking generally, the denser and stronger the negative, the stronger should be the light to penetrate it, and though less light acting longer may be all right in many cases, this "reciprocity law" fails if the light is very weak relatively to the strength of the negative. For average negatives a kerosene lamp of the duplex type, a good gas burner, or a 50 candle power electric bulb will each answer well. Daylight is usable but artificial light is to be preferred because daylight varies in intensity even within a period of short duration.

In arranging the exposing light and printing frame, it is convenient to have a board with a sliding easel or support, and the lamp at one end of it. The printing frame may then be supported at any distance from the light and duplicate exposures made with certainty if the board is marked with 6-inch distances. Bear in mind that the "law of inverse squares" applies in this as in any other printing with artificial light; that is, *the strength of the light varies inversely as the square of the distance*. Thus, if the exposure should happen to be 30

10 HOW TO MAKE LANTERN SLIDES

seconds at a distance of 1 foot from the light, it will be 4 times as much, or 120 seconds, at a distance of 2 feet.

The following table gives the *relative* exposures:

| | |
|-------------------------|----|
| 1 foot from light..... | 1 |
| 1½ feet from light..... | 2¼ |
| 2 feet from light..... | 4 |
| 2½ feet from light..... | 6¼ |
| 3 feet from light..... | 9 |
| 3½ feet from light..... | 12 |
| 4 feet from light..... | 16 |

It may be asked why the distance should be varied. One reason is that with a very delicate negative the exposure might be somewhat inconveniently short if too near the lamp. Another is that most practical workers agree that with a thin negative, especially if rather soft in contrast, a little more vigor is obtained if the frame is kept at a good distance from the light. The suitable distance, however, is a matter which each worker must find for himself, depending as it does on the character of the plate, the strength of light, type of negative, and kind of slide required. Whatever light is used should be screened either by a sheet of ground glass or a piece of tissue or wax paper stretched over a light frame. This prevents irregularities and small defects in the negative and the glass in the printing frame from printing on the slide.

The Actual Manipulations.— Clean both sides of the sheet of glass in the printing frame and the back of the negative, and place them in the frame, the negative being film side up. Now turn out the white light and turn on the darkroom lamp with a good yellow light — a Kodak-Wratten filter, either Series 00 or Series 0, is admirable and gives an ample volume of safe light, or two thicknesses of canary fabric may be used. Open

HOW TO MAKE LANTERN SLIDES 11

the box of plates and take one out, lightly dust the film surface of the negative, and lay the lantern plate on it, film side down, in the proper position, and close the frame. It may be a little difficult at first to determine which is the film side, because the film of a lantern plate is somewhat inclined to be shiny. If the plate be breathed on, the back or glass side will show condensation at once; that is, the glass will look "steamed," while the film side will not show this. After the first few dozen slides have been made, the use of backed plates is to be recommended, and this difficulty will then not occur.

We are now faced with the important question: What exposure must be given? Probably the only guide will be some legend on the lid of the box, such as "Expose for 5 to 10 seconds to an ordinary batswing burner at a distance of 2 feet." The best plan, therefore, is to give our first plate a series of exposures, say of 2, 4, 8, and 16 seconds, keeping the frame 2 to 4

| | | | |
|---|---|---|---|
| 2 | 2 | 2 | 2 |
| | 2 | 2 | 2 |
| | | 4 | 4 |
| | | | 8 |

2 4 8 16 Total exposure

feet away from the light according to its strength. To do this, place a card in front of the frame, and then, when that is in position, withdraw the card entirely, exposing the whole plate for the 2 seconds. Then

12 HOW TO MAKE LANTERN SLIDES

instantly cover a strip of the lantern plate an inch in width and give another 2 seconds, covering another strip and giving 4 seconds, and an extra 8 seconds to the fourth or last strip. It will be seen that this gives exposures as shown on the table on page 13.

The strips need not be *exactly* an inch in width, of course, but the nearer equal they are the better. It is a good plan to make marks on the frame beforehand, so that the position to which the card is to be moved may be seen at a glance, because there must be absolutely no pause between the end of the exposure and the moving forward of the card. The slide maker should have a second's timer with large dial to enable him to make precise short exposures. It is not only necessary to do it with precision, but to be able to repeat the exposure which has been ascertained to be correct.

The development should be mechanical, that is, the solution should be poured over the plate and the dish rocked for 2 or $2\frac{1}{2}$ minutes, timed by the clock, after which the plate should be rinsed and fixed. The time of development will vary with the temperature, but we may take 2 minutes as an average time if the hydrochinon and caustic soda developer is used. Fixation is rapid, but the plate should not be examined till it is completely fixed. Then, after a short wash, the test slide may be examined.

The points to look for have already been indicated. Naturally some of the strips will be better than others, and the best one should be selected and another plate exposed for the time the selected strip received. Now note the advantage of "mechanical development," by which is meant the use of a standard solution for a definite time. The exposure can be repeated ac-

HOW TO MAKE LANTERN SLIDES 13

curately by timing, and the development can also be timed, and thus the complete exposure of the entire plate will yield a result exactly the same as the selected trial strip. It is quite possible that the slide may not be all that is desired when it is seen as a whole. It may be a little too strong or not quite strong enough. If a negative is in question, this merely indicates over-development or under-development. The same applies with the slide, but with this in addition, that the longer development *may* result in slightly veiled highlights, and the shorter development *may* result in the lighter tones showing no gradation. To guard against these contingencies it is often necessary to vary the exposure a little. Thus we may say:

Slide too vigorous — increase exposure slightly
and shorten development.
Slide too flat — decrease exposure slightly and
lengthen development.

These modifications are usually necessary when the negative is a little stronger or weaker than the average.

After fixation the slide is washed thoroughly, carefully rinsed under the tap, and gently wiped with a tuft of wet cotton-batting — absorbent cotton being best, as it is free from grit and woody particles, which would scratch the soft film.

The worker is advised to persevere in the making of such contact slides until from any decent negative he can produce a clean slide of good black color, proper strength and gradation, clear highlights, and transparent shadows. When a fair measure of success has been obtained, the plates may be obtained *backed*, and the improvement in quality will be noticed at once. No attempt should be made to remove the backing

14 HOW TO MAKE LANTERN SLIDES

before development, but after it has softened during the time the plate is in the developer, it may be sponged and rinsed off before fixation.

One other point should be mentioned. If a small negative is being used, such as a film smaller than the lantern plate, some mask must be employed to protect the margins of the plate from a flood of light which might degrade the lights over the entire slide. This mask should be placed under the negative and not between the negative and the lantern plate, and must even then be of the thinnest black paper it is possible to obtain, or it will interfere with the obtaining of contact.

Warm Tones.—The next step is the production of warm-toned slides by development. In the writer's opinion, slides so made are preferable to slides toned subsequently, and they are unquestionably more permanent. The key to the variation of color is that short exposures give cold or black tones, and longer exposures followed by suitably restrained development give warm tones. Such tones will range from warm black to red or orange. In general, the most pleasing tones are the olive-green blacks, the warm blacks, purple-browns and sepias, and, for some few subjects, red. In addition to the restraining of the developer, some formulas call for dilution, and frequently additions of ammonium carbonate should be made to it. In certain cases another formula or another reagent may be used. Thus very pleasant warm blacks and brown colors may be obtained on ordinary lantern plates by the use of pyro-ammonia. It is satisfactory to make this up in two stock solutions according to the formula on the next page.

HOW TO MAKE LANTERN SLIDES 15

PYRO-AMMONIA DEVELOPER

| | |
|----------------------------|------------|
| A. Pyrogallic acid..... | 30 grains |
| Sodium sulphite (dry)..... | 120 grains |
| Citric acid..... | 3 grains |
| Water to..... | 10 ounces |

In making up this solution, dissolve the sulphite and citric acid in about 6 ounces of water, and then add the pyro and bring total bulk up to 10 ounces.

| | |
|-------------------------------|-----------|
| B. Ammonium bromide..... | 40 grains |
| Liquor ammonia (S.G. .880)... | 30 minims |
| Water to..... | 10 ounces |

Take equal parts of A and B. If the color is not brown enough, add further ammonium bromide from a 10% stock solution, increasing exposure as may be necessary. In a general way, the above pyro formula will require 5 times the exposure given the plate for a black tone with either of the developers already given.

Probably the greatest range of tones can be obtained on the gaslight type of plate, and the following methods are particularly applicable to such plates, but they may be used effectively on practically any brand. The following developer is excellent:

A. METOL HYDROCHINON

| | |
|-----------------------------|------------|
| Water..... | 20 ounces |
| Metol..... | 20 grains |
| Sodium sulphite (dry)..... | 100 grains |
| Sodium carbonate (dry)..... | 400 grains |
| Hydrochinon..... | 20 grains |
| Potassium bromide..... | 20 grains |

Dissolve these ingredients in the order given.

B. RESTRAINER

| | |
|-------------------------|-----------|
| Ammonium carbonate..... | 1 ounce |
| Ammonium bromide..... | 1 ounce |
| Water to..... | 15 ounces |

This developer will yield slides ranging from black to red, according to the exposure, and the dilution and

16 HOW TO MAKE LANTERN SLIDES

restraining of the developer. Slight variations in the plate will sometimes affect the result, but the following is right for the majority of brands. The exposure for gaslight plates is approximately minutes where one would give seconds to the ordinary lantern plate, *i.e.*, sixty times as much exposure is required. As the negatives are usually thin and delicate when these plates are in use, the exposure for a cold black color will probably be about $\frac{1}{2}$ minute at a distance of a foot from an incandescent gas burner. When warm tones are required, exposures must be considerably increased and additions of B made, B not being required when cold blacks are wanted. The following table has been published by Wellington and Ward of Elstree, England, and should prove a valuable guide.

| Color | Exposure Normal | Developer | | Development Time at 65° F., in seconds |
|-----------------|---------------------|-----------|------------------|--|
| | | A | B | |
| | | Ounces | Drams | |
| Black..... | Normal | 1 | | 20 |
| Warm black..... | N. x $1\frac{1}{2}$ | 1 | + 2 | 30 |
| Brown..... | N. x 2 | 1 | + 2 | 40 |
| Warm sepia..... | N. x 3 | 1 | + $3\frac{1}{4}$ | 50 |
| Purple..... | N. x 4 | 1 | + 4 | 60 |
| Red..... | N. x 6 | 1 | + 5 | 70 |

It will be noticed that gaslight plates (in common with gaslight papers) require longer exposures than ordinary lantern plates (or bromide papers), but develop more rapidly. The method of working to time is again very valuable as tending to the production of uniform results, and if the temperature is not 65° F. the Watkins' factorial system may be used. With the above metol-hydrochinon developer a factor of 3 is right for results of average density, that is, if 10 seconds

elapses between pouring on the solution and the first appearance of the picture, 3 x 10 seconds will be the total time of development. The appearance of the slide during development is more deceptive when working for colors than when making cold black slides; that is, the image is less on the surface and more buried in the film. This constitutes an additional reason for the use of a time method of development. Slides made by this method will not only be uniform in color, but correct in gradation. If the results are too dense or too thin, it is a sign that the exposure has been too long or too short, as the case may be, and another slide should be made. If the development is prolonged or shortened to compensate for errors in exposure, the gradation will be altered and probably the quality of the slide will be poor. Correct exposure is a matter of judgment and experience, aided by the above table, but when the factorial method of development is employed, the worker may be certain his development is not at fault, and that the exposure needs to be altered, and he can act accordingly.

Copy Slides.—As slides are used so extensively by the teacher and lecturer, no manual on slide-making would be complete without some consideration of the making of slides from prints, book illustrations, and so on. A teacher may make a rough sketch or produce a machine or architectural drawing which he wishes to have in lantern-slide form. To get this it is necessary to photograph the drawing or book illustration, and such work is usually referred to as "copying." Educational photography of this kind, which is being increasingly used in England as well as in this country, demands convenient, and, in some cases, specially

18 HOW TO MAKE LANTERN SLIDES

designed apparatus, for the teacher who makes his own slides and does other educational photography is primarily a teacher, and, therefore, however much he may be interested in photography, must work quickly and regard it as a means to an end. Theoretically, it is only necessary to fix up the drawing or book illustration, which we shall uniformly refer to as the "original," set the camera opposite to it, truly square, etc., and make the exposure. In practice, the difficulties of getting this "truly square" adjustment, *i.e.*, the lens opposite the center of the original and the plate and original quite parallel, are so great that the work becomes impracticable in the absence of suitable apparatus. We shall deal later on with the "reduction" method of making slides, that is, the copying of a larger negative down to lantern size, so that the whole picture is included but on the smaller scale; and the apparatus may be so arranged that it is convenient for both pieces of work, that is, for copying originals by reflected light and for copying negatives by transmitted light.

The first essentials are a camera with the focusing movement at the back, mounted on a shallow box which may be slid along a stout board. At one end of this board an enlarging easel may be placed, or some similar arrangement such as a drawing board fixed at right angles by means of brackets. This arrangement is shown in side and end elevation in Figure 1. A rather large easel is required, at least large enough to take comfortably the average size of originals to be copied, though it is not wise to make the apparatus clumsily large for the sake of an odd "out-size" or two. The shallow box must be used in order to lift the lens opposite the center of this easel, and it is to be provided

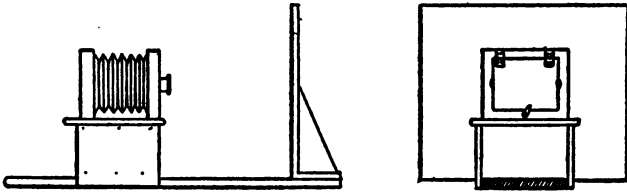

Figure 1

with runners so that it may be moved readily along the board nearer to or farther from the copy-board on which the original is pinned. Thus, the size of image may be varied as required by sliding the camera on its saddle along the board, and yet parallelism of the plate (or the ground glass focusing screen) and the original is maintained without any trouble or loss of time. Because of the focusing being from the back, no trouble arises in getting the desired scale of image. If the camera has front focusing, any attempt to focus disturbs both the conjugates, and so any attempt to secure definition disturbs the scale, and adjusting the scale disturbs the focus. Time is wasted and the worker is irritated.

Even with this arrangement it will be found advantageous to find the conjugate foci by calculation, these being the distances from lens to original and from lens to ground glass. This calculation is so simple that time will almost always be saved if it is made. It is necessary to know the focal length of the lens in use and the variation in the scale. Suppose a 5 x 7 print of any kind is being copied to lantern-slide size, so that the slide may be made by contact printing. The image will probably require to be $3\frac{1}{4}$ inches long. The rebate of the plate-holder, marginal defects, and so on, would

20 HOW TO MAKE LANTERN SLIDES

probably have reduced the size of the original to $6\frac{1}{2}$ inches in length, so that the copying reduction in size will be $\frac{1}{2}$ linear dimensions, or half-scale. Assume that the lens on the copying camera is of 6 inches' focal length. The following rule will be found simple and more easily grasped by many than a formula:

(a) Multiply the focal length of the lens by the times of reduction and add one focal length. This gives the shorter conjugate. Thus, $6 \times \frac{1}{2} = 3$ inches. $3 \text{ inches} + 6 \text{ inches} = 9 \text{ inches}$.

(b) Multiply the focal length by the times the original is bigger than the copy, and add one focal length. This gives the longer conjugate. Thus, the original is twice the size the new negative will be, so $6 \times 2 = 12$ inches. $12 \text{ inches} + 6 \text{ inches} = 18 \text{ inches}$.

Keep in mind that the conjugates always bear the same ratio as do the linear dimensions of the images. Thus, our new negative is *half* the size of the original, and 9 inches — the conjugate in the camera and on the new negative side of the lens — is *half* the other conjugate, that between the lens and the original.

This is just as easily worked out when the size of the new negative is not conveniently half, as in this case, provided fractions are used. Suppose the original is $5\frac{1}{2}$ inches long and we are copying to $3\frac{1}{4}$ as before.

The reduction is evidently $\frac{3\frac{1}{4}}{5\frac{1}{2}}$, and this we may

simplify by reducing to $\frac{1}{4}$'s — $\frac{\frac{13}{4}}{\frac{22}{4}}$. Cancel out the

4's, and we have $\frac{13}{22}$ as the scale of reduction.

HOW TO MAKE LANTERN SLIDES 21

Then $\frac{13}{22} \times 6$ inches = $\frac{78}{22}$ inches, or $3\frac{12}{22}$, to which add one focal length, *i.e.*, 6 inches, and we get $9\frac{12}{22}$ inches.

Turn the fraction over, for if $3\frac{1}{4}$ is $\frac{13}{22}$ of $5\frac{1}{2}$, it is clear $5\frac{1}{2}$ is $\frac{22}{13}$ of $3\frac{1}{4}$.

So that $\frac{22}{13} \times 6$ inches = $\frac{132}{13}$, or $10\frac{2}{13}$. Add 6 and we have $16\frac{2}{13}$ inches, the distance from lens to original.

Assuming that our measurement of the focal length is correct, and that we know exactly where the nodal points are, we could do our focusing without looking at the ground glass at all, and get perfect definition. But the nodes are not marked and there is probably a slight error in the focal length, either as marked by the maker or measured by oneself. The setting of the conjugates, therefore, will be approximately correct only, and a slight sliding movement of the camera or turn of the focusing screw will usually be necessary to get scale and definition quite correct. Nevertheless, the setting by measurement will often prove a saving of time, particularly when copying to a larger scale. With symmetrical lenses, whether rapid rectilinears or anastigmats, we may measure from the diaphragm position. The nodes are not very far apart and the diaphragm is generally between them. With some lenses of unsymmetrical construction this is near enough, but when the nodes are near the front surface of the front component, or even right outside the lens, it is better to find their positions or to inquire from the maker where the focal length should be measured from.

22 HOW TO MAKE LANTERN SLIDES

But it may be noted, chiefly as a matter of interest at the moment, that one conjugate is measured from the node of admission and the other from the node of emission, and with the ordinary rapid rectilinear lens these are separated by the inter-nodal space. The focal length of the lens, of course, is the conjugate between the image and the node of emission when a distant object is focused, and so the focal length is usually rather less than the measurement to the diaphragm under these conditions.

The copying apparatus should be set up on some stout bench or firm table so that a good light will reach the copy-board at an angle of 45° . Loose prints and drawings may be pinned to the board in a central position, holding the edges by strips of card through which alone the push pins pass, thus avoiding any damage to the original. When a print in a book is to be copied, it is usually necessary to pack up the book with others or with blocks of wood and to press the upper half flat against the copy-board by means of a sheet of stout plate glass securely tied to the board with stout string. Sometimes a large printing frame may be used, if the book is a thin one. In any case, care must be exercised to prevent distortion, that is, the original must be kept flat and parallel to the ground glass. If any valuable books are being copied from, use polished edge plate glass to avoid damage to the book. Reflections from the glass may be avoided by the use of a large black cloth hung up immediately in front of the camera, and through a hole in which the lens looks. Under ordinary circumstances and with proper 45° lighting, there should be no reflection of the source of illumination unless a very wide angle lens is being used,

and this course is to be deprecated from every point of view. If the lighting is too flat on the original, reflections may occur; and, on the other hand, if it is too much from the side, the texture of the paper of the original will be emphasized and a granular result obtained. There is little difficulty in evenly illuminating originals of moderate size, though when anything larger than 5 x 7 is being copied, the distance between window and original should be increased so as to get the illumination practically equal on both right- and left-hand sides. Really large originals are better copied out of doors, unless there is a studio with ample side and top light to work in.

The question of exposure is not a difficult one, provided some reliable actinometer is used. We have always found it best to make a simple measurement of the light and to expose in direct proportion to this under standard conditions. The stop and plate present no difficulties because their values are known. Subjects may be classified in a table. As the variations in scale are accompanied by variations in the conjugate foci, it is evident the real or actual value of the stop will never be its marked or nominal value. To avoid confusion, we refer to the stop at its nominal value, and give a "scale" table which shows the variations in exposure needed when copying to a larger or smaller scale. It is easy to make an allowance for intermediate variations in scale, if desired, though it is scarcely necessary, owing to the great latitude of modern plates, especially if backed. The starting point most convenient in copying is "same scale," and we have adopted this.

Let us assume we have a bromide print to copy and

24 HOW TO MAKE LANTERN SLIDES

that it is $5 \times 6\frac{1}{2}$ inches, which will be reduced to half scale for slide-making purposes. Assume the conjugates have been set and the final fine focusing has been done. Assume, too, that we are using a plate of about 65 Watkins and a Watkins Bee meter with the light ($\frac{1}{4}$ tint) dial. This must be hung up on the copy board close alongside the original, and the time the sensitive paper takes to match the painted tint carefully noted. Suppose such time to be 2 minutes. The exposure required, as shown by the following tables, will be 2 seconds, using the f : 8 (nominal) stop.

| Classification of Originals | Fraction of Meter Time* |
|--|-------------------------------|
| 1. Matt or semi-matt gaslight, bromide or platinum print, line drawing or pencil drawing, light steel engraving or wood-cut..... | $\frac{1}{30}$ |
| 2. Glossy purple P.O.P. or strong glossy bromide, black carbon, sepia platinum, black photogravure..... | $\frac{1}{18}$ |
| 3. Brown photogravure or etching, strong sepia toned bromides, red chalk prints... | $\frac{1}{8}$ |
| 4. Strong red chalk prints, black and brown gum prints, or bromoils..... | $\frac{1}{4}$ |

From this table it will be seen that the bromide print will require $\frac{1}{30}$ of the meter time, that is, $\frac{1}{30}$ of the 2 minutes, or 4 seconds, if we are copying same scale. As we are not, we must allow as shown in the following "scale table," giving half exposure because half scale.

Scale Table.— Calculate exposure for a same-scale copy, and then the ratios are:

| | Ratio | Exposure |
|---------------------------|------------------------|----------------|
| Same scale..... | (1 to 1) | 1 |
| Half size or about..... | ($\frac{1}{2}$ to 1) | $\frac{1}{2}$ |
| Quarter size or less..... | ($\frac{1}{4}$ to 1) | $\frac{1}{4}$ |
| Half as large again..... | (1 to $1\frac{1}{2}$) | $1\frac{1}{2}$ |
| Twice as large..... | (1 to 2) | $2\frac{1}{4}$ |

In all cases *linear* measurements are understood, that

is, 8 x 10 is twice the size, or scale, of 4 x 5, although actually four times the area.

The speed of plate mentioned, *i.e.*, Watkins 65, is suitable for any ordinary copying, but for line work, where a clean black and white result is required, it is better to use a "process" plate. This will probably be slower, but if its Watkins number is known, the exposure will be inversely proportional. That is, should the speed be Watkins 15, we should calculate exposure for the standard conditions, and then give four times as long.

In the same way, the exposure may be lessened if the plate is more rapid, as it may be if an orthochromatic plate is used for colored originals. There is a distinct advantage in using such plates with a yellow ray filter when brown and red prints are being copied. Such a combination enables the shadows of the print to be exposed without the lights being grossly over-exposed, with consequent loss of gradation.

Whatever plates are used, it is a great advantage to have them backed, or to back them as required in the darkroom. In line and diagram work this ensures clean, crisp lines, assuming the focusing to be done with precision. As we have already pointed out, the lantern plate should also be backed if the best results are desired.

Diagram Slides.— It will be apparent that the negative copied from a line diagram will show white lines on a black ground, and that the slide made from such a negative will repeat the original, showing black lines on a white ground. In the vast majority of cases it is quite unnecessary to go to this trouble of printing a slide from the negative, and the negative itself will serve admirably. Students are accustomed to the use

26 HOW TO MAKE LANTERN SLIDES

of chalk on a blackboard which gives white lines on a black ground. Such white-line slides, moreover, are pleasanter in use, as the volume of light reflected from the lantern screen to the eyes is much less than with a black-line slide. Lantern plates will usually give clean black and white results when used as negative plates for copying, but if any difficulty is found in so using them, process plates may be ordered in the $3\frac{1}{4} \times 4$ size, coated on thin glass. The plate is simply exposed in the copying camera in the usual way and developed with a clean-working developer which will give ample density. Probably the formula for hydrochinon and caustic soda is as good as anything. When focusing, care must be taken to get the subject in the exact center of the plate. This is readily done by the use of the rising and cross fronts with which the camera should be fitted, though it is often convenient to have these movements on the copy-board as well as, or instead of, on the camera. Unless such subjects are accurately centered, much time is lost in cutting special masks when binding up the slides, and as a rule these diagram slides have to be turned out very rapidly and often on the day they are required. A further advantage of the white line on black ground slide is that parts of the diagram may be colored as required. After the slide is dry, any of the lines may be washed over with a dye, thus obtaining white, green, red, or other colored lines as desired. The perfectly opaque black ground does not show the dye so that such coloring does not need any great expenditure of skill.

Dark-line or white-ground slides *may* be made in two or three colors, but the method is lengthy, involving the production of a negative for each color required.

Suppose a slide is required to show parts of the diagram in black, parts in red, and parts in blue. Three negatives are made and the parts to appear black and red are blocked out in one of these which is marked "blue;" in another, the parts to appear blue and black are blocked out and the negative marked "red;" and in the third, marked "black," the parts to be red and blue are stopped out. The three slides are then made, *not by contact*, but in the camera in the way we shall presently describe. It must be noted that the *black* one should be produced in the usual way, *i.e.*, the film of the copied line negative towards the film of the lantern plate, the lens and conjugate distances being between, of course. The *red* one made on a lantern plate requires the "red" negative to be turned round in its carrier so that the film is away from the lens. The *blue* one must be made on a film, choosing as slow a film as may be obtained, and for this it is immaterial whether the "blue" negative is reversed in the carrier or not. When all three are made, the black is left, the film is toned blue by the iron toning method, and the red is obtained by copper or uranium toning or by bleaching as for toning bromide prints and redeveloping with Schlippe's salts. The slide is bound up with the film sandwiched between the two plates, and as one plate will have its film towards the spectator and the other plate its film away from the spectator, the reason for making one of them reversed will be apparent. The preparation of such a slide involves precise working and takes up a good deal of time, but for certain work where effective and telling slides are required for important public lectures, diagrams or tabulated results so displayed are worth the trouble expended.

28 HOW TO MAKE LANTERN SLIDES

It may be well to point out here that whenever a slide is made in which the negative is used as the slide, the "spotting" of the slide (*i.e.*, the affixing of the white spots to indicate to the lantern operator how the slide is to be placed in the carrier of the lantern) will be on the opposite side to that when the slide has been made from a negative. This is obvious when one remembers that the negative has to be held up *film away* to see the image correctly, while the slide made in the ordinary way from a negative has to be held up *film towards* you to see the image correctly.

Portraiture.— Before leaving the question of copying, something must be said about portrait slides. A good deal of trouble is found on occasion in making slides from portrait negatives which have been retouched, the retouching appearing very definitely in the slide as such. What is necessary is to obtain a sufficient disturbance of definition to blend this grain or stipple of the retoucher without producing any more blur of the picture than possible. One method is to place a sheet of thin celluloid between negative and lantern plate when making the slide by contact. When reducing in the camera, a sheet of thin plate glass may be placed in front of the lens and swiveled during exposure. The thickness of the glass and the degree of swiveling needed must be matters of experiment. This method is useful when making slides from any more or less granular original, such as an autochrome. But we are dealing with the matter now because one solution of the problem is the making of a fine quality print on smooth paper, interposing celluloid if necessary, and doing any desired control work in printing such as "sunning_down," printing up the lighter tones when

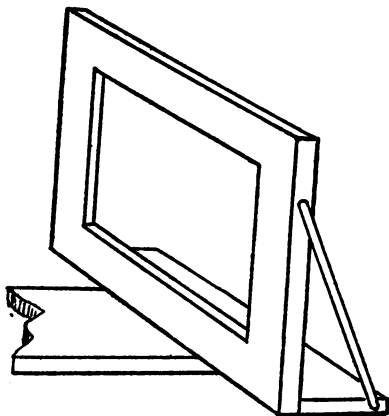

Figure 2

desirable, and so forth, and then copying this print to the size required and making the slide from the copied negative. Such a print may be made on some print-out gelatine paper, and, as we shall see presently, may be copied by a weak artificial light without going to the trouble of toning and fixing it — an obvious saving of time.

Slides by Reduction.— In the writer's opinion, the method of making slides in the camera is always superior to that by contact. The definition is better, for seldom is there absolute contact, whatever the pressure, in an ordinary printing frame. Further, when working by contact one often has to compromise and sacrifice some of the subject. There is less risk of mechanical injury to the lantern plate, and certainly less risk to the negative. For combining landscapes and skies, the camera method and projection in the enlarging lantern are both much more simple than contact

30 HOW TO MAKE LANTERN SLIDES

work. The camera as used for copying and the saddle carrying it, together with the board on which it slides, are satisfactory, but the copy-board requires to be replaced by a frame carrying a set of nested carriers. It is quite an easy matter to construct the copy-board and the negative carrier-board so that either may be clamped at the end of the long board on which the camera slides. Figure 2 will show this construction, and if the copy-board is made in the same way, either may be attached with a couple of ordinary U-clamps. When the negative is placed in the carrier, the various adjustments are precisely the same as when copying a print, but, of course, the negative must be illuminated by *transmitted* light. This may be done in various ways, and we may consider two methods for daylight first.

Where the workroom window gives a fairly open outlook, the use of a double diffuser is quite satisfactory, especially with the smaller sizes of negative. Thus we may pin a large sheet of white tissue paper to the window frame and place behind the negative (but 2 or 3 inches from it) a sheet of fine ground glass. The great advantage of this diffuser method is that the entire arrangement is inside the room and so one is not limited in any way by wind and rain or other bad weather conditions. If there is any choice of room it is well to select a north window so that the sun will not shine on the window and interfere with the equality of the illumination.

When equalizing the light over the negative by means of a reflector, it is often necessary to keep the window open unless it is glazed with plate glass, or a pane of the glass can be replaced by plate glass. Or a sheet of

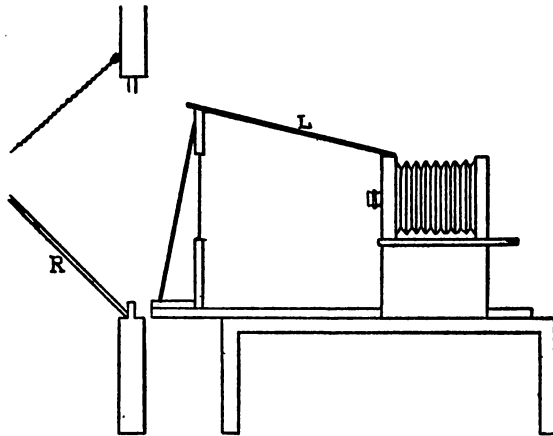

Figure 3

ground glass may be placed behind the negative, but this, with the window pane as well, absorbs a good deal of light and the increase of exposure is troublesome when slow chloride (*i.e.*, the gaslight type) plates are in use. Still, one must be guided by circumstances and often has to choose the lesser of two evils. Figure 3 is a diagrammatic sketch of the arrangement, the window being shown too small, of course. The reflector should be placed as at R, in Figure 3, extending from a point about 8 inches below the negative to such a height that direct illumination from the sky will not illuminate the upper part of the negative. The angle at which the reflector should be supported may be determined by inspection of the ground glass of the copying camera and should not be arbitrarily fixed at 45° from the vertical. It will usually need to be inclined a little more. An excellent reflector is made by an artist's canvas painted dead matt white. This is

32 HOW TO MAKE LANTERN SLIDES

light, easily cleaned, and repainted, and unaffected by a shower of rain. The matt white may be obtained by the addition of kerosene to a turpentine oil paint. If there is no risk of rain a washable distemper is possibly still more effective.

Whichever arrangement is adopted, it is necessary to close in the space between the negative and the lens so that the only light passing through the lens is that which has passed through the negative also. Otherwise the slide would be degraded by light reflected from the surface of the negative. This closing in may be conveniently done by laying a couple of laths or a light board across, as shown at *L*, Figure 3, and throwing over a focusing cloth.

Alternative Method with Two Cameras.—In all cases where a worker is producing large numbers of slides, whether for trade or professional purposes, or for one's own use as a teacher or lecturer, it is an advantage to have apparatus specially arranged in the way we have just described, and, in fact, we will go further than that and say that such an equipment carefully and accurately made and fitted with a scale reading in inches and fractions of an inch from the negative position backwards will very soon have paid for itself in time and material saved and improved quality of results. Further, the use of artificial light, arranged as we shall shortly describe, still further simplifies working, not only because it is always available, but because of its uniformity and the consequent time saved in arriving at the exposure. It may be well, however, at this point to suggest another very effective method of supporting the original negative and of closing in the space between negative and lens

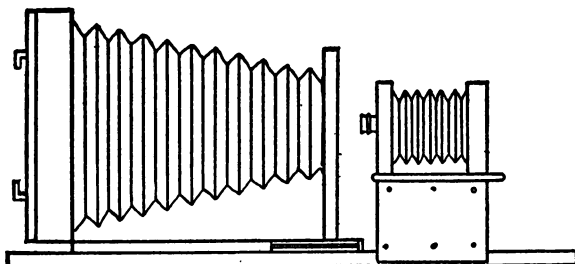

Figure 4

very efficiently. This is the use of two cameras facing each other, as shown in Figure 4. The smaller one is, of course, our old friend of the copying outfit, mounted on its saddle, and the other — the larger one — is another instrument, preferably focusing from the front. In all copying and slide making the working camera should focus from the back so that any alteration of the focus does not disturb the scale of image decided on. That is, with a back focusing camera it is possible to set the conjugate from lens to original — whether that is a print or a negative — and to focus as may be needed without disturbing this conjugate. A front focusing camera would, of course, disturb *both* conjugates every time focusing was attempted. But for simply holding the negative up against the light equalizer, whatever form of equalizer is adopted, the front focusing camera is to be preferred, if it can be obtained. Sufficient space, must be left between the two fronts to admit the hand for the manipulation of the stops, and usually it will be an advantage to take away the front board of the large camera. Some sort of reversing back should be fitted which will take the carrier for holding the negative, or it may be held in a

34 HOW TO MAKE LANTERN SLIDES

damaged plate-holder from which the central plate separator has been cut away. The space between the two cameras will do no harm unless there is bright light in the room from some other window, and in any case it may be covered over by throwing a thin focusing cloth across. Exposing may be done with the shutter release, if the lens is mounted in a shutter, or the hand may be inserted under the cloth, or a large sheet of black card may be placed behind the negative (on the equalizer side, that is), and the exposure made by removing that and replacing it. An old and somewhat dilapidated camera may often be purchased for a dollar or two, and will answer quite well for such work as this, and then there need be no hesitation in making any alteration, as it will be used exclusively for the slide-making work. Even a disused daylight enlarger of the fixed focus type may be employed, removing the septum carrying the lens and cutting the cone shorter, if necessary, so as to serve for average conditions. Whenever anything of a makeshift character in the apparatus is employed, the setting of the conjugate from lens to negative becomes more important, as after-adjustment may be difficult; and for those who do not care to work out the conjugates for themselves, we give the following table, worked out for reductions and enlargements in the smaller sizes. No one is likely to wish to enlarge more than 3 diameters in slide making, and seldom will a reduction to less than 1-3 be desired. In many cases the focal length of the worker's lens will not agree, and the degree of enlargement or reduction may not be quite the same, but the nearest figures must be taken and minor adjustments made as required.

| Focal length of lens | Reduction | | | | | | |
|----------------------|-------------|--------------------|--------------------|--------------------|--------------------|--------------------|--------------------|
| | 1-1 | $\frac{2}{3}$ size | $\frac{3}{4}$ size | $\frac{4}{5}$ size | $\frac{1}{2}$ size | $\frac{2}{5}$ size | $\frac{1}{3}$ size |
| | Enlargement | | | | | | |
| | 1-1 | 1-1 $\frac{1}{4}$ | 1-1 $\frac{1}{2}$ | 1-1 $\frac{3}{4}$ | 1-2 | 1-2 $\frac{1}{2}$ | 1-3 |
| 4 | 8 | 9 | 10 | 11 | 12 | 14 | 16 |
| 4 $\frac{1}{2}$ | 8 | 7 $\frac{1}{2}$ | 6 $\frac{3}{4}$ | 6 $\frac{1}{2}$ | 6 | 5 $\frac{3}{4}$ | 5 $\frac{1}{2}$ |
| 5 | 9 | 10 $\frac{1}{4}$ | 11 $\frac{1}{2}$ | 12 $\frac{3}{4}$ | 13 $\frac{1}{2}$ | 15 $\frac{1}{4}$ | 18 |
| 5 $\frac{1}{2}$ | 9 | 8 $\frac{1}{10}$ | 7 $\frac{1}{2}$ | 7 $\frac{1}{4}$ | 6 $\frac{3}{4}$ | 6 $\frac{3}{10}$ | 6 |
| 6 | 10 | 11 $\frac{1}{4}$ | 12 $\frac{1}{2}$ | 13 $\frac{1}{4}$ | 15 | 17 $\frac{1}{10}$ | 20 |
| 6 $\frac{1}{2}$ | 10 | 9 | 8 $\frac{3}{4}$ | 7 $\frac{3}{4}$ | 7 $\frac{1}{2}$ | 7 | 6 $\frac{1}{2}$ |
| 7 | 11 | 12 $\frac{3}{8}$ | 13 $\frac{3}{4}$ | 15 $\frac{3}{8}$ | 16 $\frac{1}{2}$ | 19 $\frac{1}{2}$ | 22 |
| 7 $\frac{1}{2}$ | 11 | 9 $\frac{1}{10}$ | 9 $\frac{1}{2}$ | 8 $\frac{1}{4}$ | 8 $\frac{1}{2}$ | 7 $\frac{1}{10}$ | 7 $\frac{1}{2}$ |
| 8 | 12 | 13 $\frac{1}{4}$ | 15 | 16 $\frac{1}{2}$ | 18 | 21 | 24 |
| 8 $\frac{1}{2}$ | 12 | 10 $\frac{3}{8}$ | 10 | 9 $\frac{3}{4}$ | 9 | 8 $\frac{3}{8}$ | 8 |
| 9 | 13 | 14 $\frac{3}{8}$ | 16 $\frac{1}{2}$ | 17 $\frac{1}{2}$ | 19 $\frac{1}{2}$ | 22 $\frac{1}{2}$ | 26 |
| 9 $\frac{1}{2}$ | 13 | 11 $\frac{1}{10}$ | 10 $\frac{3}{8}$ | 10 $\frac{3}{4}$ | 9 $\frac{3}{4}$ | 9 $\frac{1}{10}$ | 8 $\frac{3}{8}$ |
| 10 | 14 | 15 $\frac{3}{8}$ | 17 $\frac{1}{2}$ | 19 $\frac{1}{2}$ | 21 | 24 $\frac{1}{2}$ | 28 |
| 10 $\frac{1}{2}$ | 14 | 12 $\frac{3}{8}$ | 11 $\frac{3}{8}$ | 11 | 10 $\frac{3}{8}$ | 9 $\frac{3}{8}$ | 9 $\frac{1}{2}$ |

Each square contains the two conjugates. The lower conjugate will always be where the larger image is, *i.e.*, in copying 8 x 10 to 4 x 5 with a 6-inch lens, the smaller image is in the camera, so the shorter conjugate, viz. 9 inches, will be from lens to plate. The larger negative is the 8 x 10 negative (or print), and the longer conjugate, namely, 18 inches, will be from negative (or print) to lens. With longer foci the distances are proportional, *i.e.*, with 8-inch lens double those for a 4-inch lens.

Artificial Light.—The commercial worker, and those who make their slides for lecture purposes may rank as such, cannot afford to be dependent on the vagaries of the weather. There are so many methods available that the local conditions may be met without any difficulty. The simplest method perhaps is to use one of the paraboloid enlargers, which may be obtained in this country for use with any camera of suitable size. Of course, it must be remembered that it is the original negative that is to be illuminated. In the case of *enlarging*, probably a 4 x 5 or smaller negative is to be illuminated, but we are *reducing* and it may be that

36 HOW TO MAKE LANTERN SLIDES

we are working from negatives as large as 8×10 . These reflectors usually take the form of a paraboloidal surface, or set of mirrors, and the light source, an electric tungsten lamp or a Welsbach gas burner, is placed nearly at the principal focus of the curve. In some cases there are two lamps, one at each side, and, of course, two smaller parabolas forming a continuous curve. Duplex oil lamps may be used where gas is not at hand. A reflecting surface of matt white is much to be preferred to a polished one, or, as an alternative, a sheet of finely ground glass may be used to diffuse the reflected light.

By interposing two or three sheets of ground glass between a fairly powerful light and the negative, it is possible to illuminate evenly a small negative. The glasses should be at least an inch apart. If a powerful arc lamp is used and the distance between light and negative is considerable, negatives of greater size may be illuminated. A better light source, however, is a Cooper-Hewitt M tube, as the larger light source requires fewer diffusing glasses. A further advantage is that the heat evolved is much less than with arcs. These mercury-vapor lamps are powerful and therefore advantageous where slow plates are in use, such as chloride plates or collodio-bromide emulsion.

A method for which we have a distinct preference where the highest quality of slides is desired, is to throw a powerful light on to a flat white surface, such as a sheet of white blotting or cartridge paper or a smooth matt card. Figure 5 shows the arrangement, *R* being the white reflecting surface. The negative carrier, shown in Figure 2, should be used, but care must be taken that the margins are wide enough to keep all

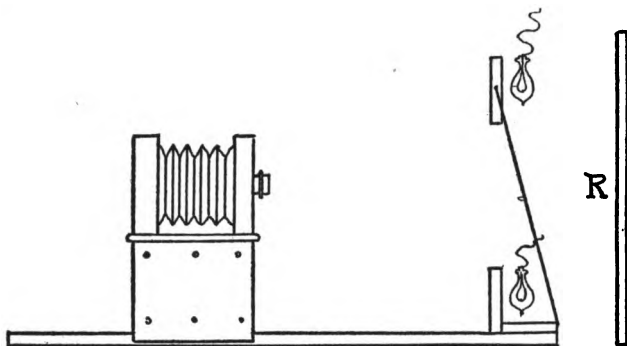

Figure 5

direct light from the lens. The negative also must be screened from direct light. In general this may be done by the use of a curved tin reflector of ample size on each lamp. Looking from the camera position and through the negative, nothing at all must be visible but the evenly lighted dead white flat reflector *R*. A couple of small enclosed arc lamps may be used, and by keeping the flat reflector at a fair distance, negatives up to 11 x 14 may be illuminated quite evenly. Some workers may prefer to use the nitrogen-filled tungsten lamps, and four of such lamps will readily light negatives of this size. They have the advantage over arcs that they are clean, ever ready, possibly cooler, and certainly quieter. For smaller negatives, say 8 x 10 and downwards, four lamps of 50 candlepower may be used, unless very slow plates are being employed. It must be borne in mind that, when enlarging, the light is distributed over a considerable area, while in slide making it is to some extent concentrated on a small one. Obviously, the same arrangement may be adopted with Welsbach mantles or with acetylene burners,

38 HOW TO MAKE LANTERN SLIDES

though a little contrivance is needed to place the lamps one above the other on each side, and four lamps are usually necessary unless the original is quite small.

Print Copying by Artificial Light.— It will be obvious that if we can illuminate evenly an area large enough to reflect through a negative, we can also illuminate a print of that size. Thus, with the arrangement shown in Figure 5, the negative and carriers may be removed, and the white reflecting surface also, and a print pinned to the board *R* will be properly lighted. The dual use of this arrangement is a great argument in its favor, particularly as the change from negatives to prints can be made so readily. In cases where Welsbach burners or 50 candlepower electric lamps are used, it is possible to copy untuned and unfixed printout paper prints. This enables "sunning down," double printing, and other control to be done in a daylight printing process and a new negative made embodying these modifications. From this new negative lantern slides or enlargements may be made as may be desired. The lighting of the original is even, and being from both sides is practically grainless. Some care is needed in the placing of the lights and the focal length of lens chosen, if we are to avoid surface reflections from the margins of the print. The determination of exposure when copying by these less powerful lamps is best done by working from a table based on a few experimental tests, as the use of the meter would be too slow for convenience. With arc lamps, of course, the meter is as sensitive as to good daylight.

Use of the Condenser.— Where the maximum size of negative worked from is not over 5 x 7, the cost of a condenser is not excessive, and, of course, for commer-

cial work it often pays to use a condenser for much larger sizes. Any of the more powerful concentrated lights may be employed, though the choice will usually be made from the arc, a high-power tungsten, or acetylene.

Arc Light.— The arc light is very intense and also highly actinic, particularly the enclosed arc, so that small stops may be used, dense negatives worked from, and very rapid exposures made — all rather important points in trade work, the use of small stops enabling rapid focusing at a large aperture, the stopping down ensuring critical definition. A drawback is that the light is subject to “flicker,” which is annoying and rather irritating to the worker’s eyes. The heat evolved is also considerable, and it is advantageous to hang the lamp in another room, building the condenser into the wall. Constant evenness of illumination may be secured by placing a sheet of ground glass between the lamp and the condenser, a course which also tends to protect the condenser from the danger of cracking.

The Tungsten Lamp.— Concentrated-filament, nitrogen-filled tungsten lamps have proved their value in the enlarger, and they are equally valuable in this reduction work. Though the maximum illumination is obtained with a condenser, very good results may be got by using the parallax condenser so long as the negatives are of moderate size only.

Acetylene.— The acetylene flame is concentrated and very intense, and as such is well suited to condensers. It is the ideal illuminant for the country man who has neither gas nor electricity in his house. If such a triple burner and reflector as that supplied in the Ingento enlargers can be secured, an unusually strong and even

40 HOW TO MAKE LANTERN SLIDES

illumination can be obtained. The use of what is called "compressed," but what is really *dissolved* acetylene, such as is used for automobile headlights, is to be preferred to generating one's own acetylene.

In all cases where the condenser is used, it will be found essential to employ some diffusing medium as well, usually a sheet of ground glass between the lamp and the condenser; and if the intensity of the light will allow of it, we like to have another sheet of acid-etched focusing-screen ground glass between the condenser and the negative, keeping the condenser and glass close to each other and the negative as far as may be from the ground glass, if possible a couple of inches. This prevents the grain of the ground glass from being in focus on the lantern slide. In cases where the size of negative taxes the covering power of the condenser, it may be necessary to dispense with the sheet of glass on the negative side and to place the negative close up to the condenser.

The Use of the Enlarging Lantern.— Subject to certain limitations, the enlarging lantern may be used for slide making. Clearly, it will seldom be available for large negatives, as the amateur rarely enlarges from anything above 5 x 7 and more often 4 x 5 is the largest negative provided for. At the same time, the worker whose enlarger is only for 4 x 5 probably does not work any larger camera. There is nothing to prevent slides being made by projection just as enlargements are made, provided the enlarger has sufficient focal capacity. Suppose we are enlarging from 4 x 5 to 5 x 7; that is, an enlargement of approximately $1\frac{1}{2}$ times, and that the apparatus is fitted with a $6\frac{1}{2}$ inch lens, the distances from lens to easel and lens to negative will be as may

be seen by reference to the table on page 35, $16\frac{1}{4}$ inches and $10\frac{5}{6}$ inches. That is, the focal capacity, or extension of the enlarger, must be at least $10\frac{5}{6}$ inches. Enlargers are designed so that the extension is sufficient for enlarging with the lens of average focal length. But for reduction the conjugates are reversed; that is, the longer conjugate is between lens and negative, and in many cases the extension is insufficient. Making a lanternslide from 4×5 means a reduction of, say, $\frac{2}{3}$, so that the same conjugates are used, only the distance from lens to negative is now $16\frac{1}{4}$ inches. Many enlargers will not give as much as this. Two courses are open: either to fit an extension cone or tube to the front, or to use a lens of shorter focal length. Thus, a 4-inch lens would give a major conjugate of 10 inches, but the minor conjugate would be only $6\frac{2}{3}$ inches, and this short distance renders it awkward to place the lantern plate on the easel and to do any manipulation which the open position would otherwise facilitate. Instead of focusing on the easel in enlarging fashion, the easel may have a $3\frac{1}{4} \times 4$ inch hole cut in it, and focusing may be done from the other side of the easel, on a piece of ground glass, replacing this by the lantern plate for the exposure. This, however, destroys certain definite advantages of the projection method, and the use of an extension cone is much to be preferred. The front of the lantern is large enough in most cases to allow of an extension — a sort of truncated pyramid — being fitted, and the length may be made in accordance with the degree of reduction required, the original extension of the enlarger, and the focal length of lens used. A quite effective extension may be made from a spare front lens board, a piece of thin hard wood for the front,

42 HOW TO MAKE LANTERN SLIDES

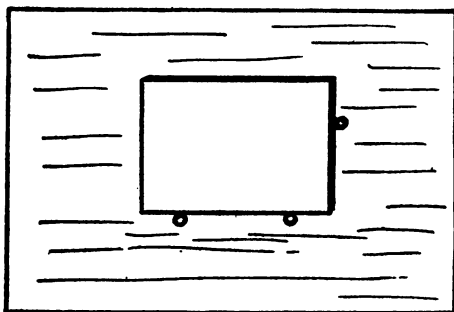

Figure 6

and stout card for the sides, the corners being bound with strips of linen and the whole covered with black paper. A spare flange will be needed for the front in preference to disturbing that on the enlarging front board.

Equipped in this way, and leaving ample space between lens and easel, one may turn out slides with great rapidity. A piece of smooth white paper pasted on a waste lantern plate forms the focusing screen; this is supported on two blanket pins, and its lateral position determined by a third, as shown in Figure 6. Glass-headed push pins, so admirable for most work, are not suitable here because light striking the polished glass is reflected on to the plate, causing fog. If the easel is covered with a piece of thick cork, or of cork carpet, these blanket pins may be pushed into it, as required, in a moment. The surface of the easel should be black, whether the lantern plates are backed or not. When working with the camera some time is occupied in adjusting the desired portion of the image centrally on the ground glass, but by the enlarger method the paper-covered plate is simply moved until it is seen that the

image is falling correctly on to it, and the three pins are then pushed into the easel so as to support it. The lens being capped, the focusing plate is replaced by the lantern plate and the exposure made. The whole of the time occupied in loading and unloading slides is saved, and in cases where, say, a dozen slides are required from a negative, they may be exposed as rapidly as are gaslight prints in a printing machine. The third blanket pin may be inclined very slightly towards the plate, and then, without casting any shadow on to the plate, it will prevent any tendency on its part to fall forward. This sideways inclination should be *very* slight, and the sharp edge of the glass grips the pin quite firmly. The method gives much facility to combination printing, particularly the adding of skies, as will be seen when that work is dealt with.

Collodio-Bromide Plates.—Although exceedingly fine slides may be made on commercial plates, some of the older methods of slide making give unsurpassed results. The albumen process we may dismiss because few would care to go to so much trouble nowadays when results of magnificent quality may be got more easily by other methods. Wet collodion is very useful for certain classes of commercial work, but it is probably rather too tricky for the amateur, and the constant handling of silver baths is likely to be objected to because it produces badly stained fingers. But the use of collodio-bromide may be recommended to the lantern-slide enthusiast who wishes to produce distinctive results. The plates must be prepared at home, so that another interest is given to the work. The methods are not complicated, but, as we have said, the process is one to be recommended to the enthusiast rather than to the

44 HOW TO MAKE LANTERN SLIDES

utility-slide maker. An enormous mass of literature on the process exists, Abney's "Photography with Emulsions" giving many alternative methods. But confusion always arises from a multitude of counselors, and the process has been admirably epitomized by G. T. Harris in "Practical Slide Making." We cannot do better than quote his instructions for preparing the plates and producing slides on them.

"The first consideration in collodion emulsion processes is the supply of pyroxyline. To make pyroxyline even on the small scale necessary for batches of collodion emulsion would be an injudicious proceeding for the lantern-slide worker, owing to the care and specialized knowledge demanded in its preparation. The only satisfactory way for the small consumer is to procure the most suitable cotton some reliable house can supply for the purpose. Fortunately, emulsion processes do not demand such extreme niceties in the preparation of the cotton as does collodion for wet-plate work. One of the best means of procuring a cotton of sound quality for emulsion work is to obtain a good commercial sample, dissolve it in cheap solvents, and precipitate it in water. The cotton thus prepared gives a particularly bright and limpid collodion, the improvement in quality being well worth the slight extra trouble involved in its precipitation.

"To prepare precipitated cotton, take 400 grains of ordinary commercial pyroxyline (guncotton) and dissolve it in equal parts of denatured or wood alcohol and ether, 10 ounces of each; the specific gravity is not of much importance. Let the collodion thus prepared stand for a couple of days, then filter it through muslin. Pour the filtrate from a height of 2 or 3 feet in a thin

stream into a vessel of cold water, stirring vigorously the while. The result of this is to precipitate the cotton in a spongy mass, which must be well washed with several changes of water, pressed as dry as possible in a clean cloth, and carefully dried in a hot water bath. Thus prepared, any ordinary commercial pyroxyline will give a cotton capable of producing satisfactory emulsions. The formula for preparing a washed emulsion is as follows:

| | |
|--------------------------------|------------|
| A. Pyroxyline..... | 60 grains |
| Alcohol, denatured or wood.... | 2¾ ounces |
| Ether .730..... | 2¼ ounces |
| B. Ammonium bromide..... | 63 grains |
| Water..... | 100 minims |
| Alcohol..... | 1 ounce |
| C. Silver nitrate..... | 100 grains |
| Water..... | 60 minims |

The pyroxyline is first dissolved in the alcohol and ether, then the ammonium bromide is dissolved in the hundred minims of water, heat being applied if necessary, and the alcohol added. This bromide solution is added little by little to the collodion (A) with vigorous shaking. The silver nitrate is now dissolved in the given quantity of water by the aid of heat, and, in the darkroom, added to the bromized collodion a little at a time with constant shaking. A creamy emulsion is the result, having a deep ruby color by transmitted light. This emulsion should now be set at one side for twenty-four hours to ripen, and when this has taken place, it is poured into a clean porcelain tray to allow the solvents to evaporate previous to washing. When the pellicle has so far set that it can be torn into firm shreds with a glass spatula, it is broken up into small pieces and put into a suitable

46 HOW TO MAKE LANTERN SLIDES

vessel filled with cold water, the water being frequently changed for about twelve hours.

"On the conclusion of washing operations the pellicle is collected in a clean cambric handkerchief, and as much water as possible is discharged by twisting the pellicle into a firm ball. It has now to be dried. My own way of doing this is to cover the pellicle twice with absolute alcohol. The pellicle being now thoroughly dried, it has to be redissolved in a mixture of 4 ounces of alcohol with 4 of ether. In my own work I use absolute alcohol .800 and methylated (or pure) ether of .730.

"Having redissolved the pellicle in the above-mentioned quantities of solvents, all that remains to be done before coating plates is to filter it through absorbent cotton loosely placed in a glass funnel, covering the funnel with a piece of glass during the operation to prevent as much as possible the evaporation of the solvents. To prepare the plates for coating, they are first washed in hot soda and water, then rinsed, and placed in an acid bath: sulphuric acid, 1 ounce; water, 10 ounces. From this bath they are well washed under the tap until the water drains off in a perfectly even manner, and when the surplus water has run from the plate, it is flowed over twice with the following solution, which should be well filtered:

| | |
|------------------|------------|
| Gelatine..... | 120 grains |
| Chrome alum..... | 5 grains |
| Water..... | 20 ounces |

The coated plates are placed upright in a rack to dry, taking care that no dust settles on them.

"An hour or two before coating the gelatinized plates the collodion emulsion is well shaken; the object of doing this some time previous to coating being to allow

any coarse particles that may be present to settle. A pool of emulsion is poured upon the center of the plate, flowed around as in the wet collodion process, and the surplus returned to a separate bottle for refiltering, the plate being gently rocked to prevent the formation of 'crapey' lines. When set, it may be placed in the drying box used for gelatine plates, to become perfectly dry, or it may be placed on a shelf in a light-tight cupboard, as drying occupies but a short time.

"The plates from this emulsion will be found very slow for camera exposures, and though 'organifiers' are not often used in conjunction with washed emulsion, they are to be recommended if the plates are to be used in the camera, from the additional sensitiveness they confer. Prepare a strong solution of freshly ground coffee and filter it. When the plate has been coated with the emulsion, place it in a dish of distilled water, wash it until all greasiness has disappeared, then flow over it several times the solution of coffee, and set it upright to drain and dry in the usual manner.

"To those who prefer an unwashed emulsion, the next formula may be commended. It has given the writer great satisfaction, and the color of the transparencies, when a coffee preservative is used, is a very nice warm brown. Of course, the designation 'unwashed emulsion' is not strictly correct, and may mislead the novice. The by-products are removed just as much in the case of an 'unwashed' emulsion as they are in the case of a 'washed,' but in the one case they are removed by washing the mass of emulsion, and in the other the plates are coated with the emulsion still containing the by-products, and these are washed away from the coated plates. It will be thus seen that by employing an un-

48 HOW TO MAKE LANTERN SLIDES

washed emulsion the drying of the pellicle and subsequent redissolving are done away with.

"If it is asked, wherein does the washed emulsion possess any advantage over the unwashed, it may be answered that, with the latter, unless used up at once, the by-products are liable to affect the sensitiveness and quality of the emulsion. In the case of the washed emulsion no such deterioration need be apprehended, and the emulsion remains in perfect condition for a long time, so that a supply is always at hand from which to coat what plates may be wanted. And it may be mentioned here that it is better to coat a limited quantity of plates and use them up within a reasonable time than to convert the whole stock of emulsion into plates sufficient to last for a year or more.

"The formula for an unwashed emulsion is:

| | |
|---------------------------------|-----------|
| Pyroxyline (precipitated)..... | 24 grains |
| Zinc bromide. | 38 grains |
| Ether (methylated or pure)..... | 2½ ounces |
| Alcohol (absolute)..... | 1½ ounces |

To sensitize the above, 30 grains of silver nitrate are dissolved in the smallest quantity of water possible, and 2 drams of boiling alcohol added. This is emulsified into the bromized collodion in the manner already described under washed emulsion. It is now set aside to ripen for 24 hours, when it is ready for coating on to the plates. The plates require the same previous treatment of cleaning and gelatinizing as already described.

"Coating the plates with the emulsion is, of course, done in the same way as with the washed emulsion, but when the emulsion has set on the plate it is placed in a tray and well washed in running water for about five minutes, when it is taken out, flooded several times with

the coffee preservative already mentioned, and placed in the drying box.

"Before the development of a collodio-bromide plate takes place, it should be given a preliminary soaking in a bath of alcohol and water (equal volumes of *absolute* alcohol and water, or undiluted *proof* spirit) to make the film sufficiently pervious for the developer to act upon it. Development may be effected by holding the plate in the hand, as is done with wet plates, or it may be placed in a dish, as is done with gelatine plates.

"The development of a collodio-bromide plate occupies an intermediate place between that of a gelatine and a wet plate. The image appears quicker and density is obtained sooner with the collodio-bromide than with the gelatine plate, but both are much slower than with a wet plate.

"Many formulas may be used for developing collodio-bromide plates — ferrous oxalate, practically any of the modern reducers (such as metol, amidol, hydrochinon, etc.), and, perhaps, best of all, pyro and ammonia. It must be observed that as collodion emulsions fog under the developer more easily than gelatine, any developer used must be considerably weaker than would be the case if used for gelatine.

"Lantern slides upon collodio-bromide plates have a good range of tone—from pure black to cherry red—depending upon the duration of exposure, but the color most readily got and eminently characteristic of a good collodio-bromide slide is a warm brown, which, in my opinion, is the one most suitable for lantern slides.

"For the production of black tones, I have used with much satisfaction an eikonogen developer made as formulated on the next page.

50 HOW TO MAKE LANTERN SLIDES

| | |
|--------------------------|------------|
| Sodium sulphite..... | 185 grains |
| Potassium carbonate..... | 77 grains |
| Eikonogen..... | 46 grains |
| Water..... | 4 ounces |

“Should the highlights of the slide after fixing show the least veil on placing the slide down upon a piece of white paper, add to the developer a few drops of 10 per cent bromide solution. After soaking the exposed plate in the alcohol bath mentioned above, wash it under the tap until all greasiness has disappeared; then, holding it between the finger and thumb, pour on about 1 dram of the eikonogen developer and rock the plate to and fro. The image will quickly appear, and the detail will keep appearing under the developer in a beautifully even manner until full density is obtained. The slide maker who knows only gelatine plates will require to be constantly on his guard at first against attaining excessive density with collodion plates. The image is never lost sight of with these as with gelatine plates, and as in the fixing bath they lose very little of the fictitious density given during development, it is only necessary to carry development slightly beyond what is wanted in the finished slide.

“Under-exposure is fatal to success with collodio-bromide, for nothing like forced development is permissible with these plates. The exposure must be such as will leave only the highest lights unreduced when development is finished. Considerable over-exposure can be quite successfully managed by washing off the developer as soon as the detail is out, and gaining density by re-development in the manner described further on.

“The developer I myself prefer contains ammonia, and is as formulated on the next page.

HOW TO MAKE LANTERN SLIDES 51

| | |
|-----------------------|------------|
| A. Pyrogallol..... | 36 grains |
| Sodium sulphite..... | 108 grains |
| Water..... | 3 ounces |
| B. Ammonia .880..... | 20 minims |
| Ammonium bromide..... | 30 grains |
| Water..... | 3 ounces |

Take half a dram of each to develop if the plate is held in the hand, more where a dish is used.

“The exposure with alkaline pyrogallol will be prolonged to quite three times that necessary for eikonogen, but the color of the slide will be wholly different — a purplish or warm brown of great beauty.

“If development shows the exposure to have been considerably greater than necessary, wash off the developer as soon as the detail has appeared, and apply the following to gain opacity:

| | |
|------------------|-----------|
| Pyrogallol..... | 20 grains |
| Citric acid..... | 40 grains |
| Water..... | 10 ounces |

Sufficient of this to cover the plate is poured into a clean measure, and a few minims of a 2 per cent solution of silver nitrate added. This intensifier is then applied to the plate until sufficient density is gained. By this means slides of great excellence may be produced.

“The fixing may be performed with potassium cyanide (25 grains to the ounce) or with sodium hyposulphite. Potassium cyanide is rather to be deprecated as a fixing agent, though several experienced collodio-bromide workers advise its use. It is certainly easier to intensify a plate after using cyanide; but, on the other hand, if the application of cyanide continues after the removal of the unaltered bromide, the halftones of the image will most certainly be attacked.

"The washing after fixing is a very simple affair compared with that necessary for gelatine plates. Five minutes under running water is ample, and the slides may be set up to dry spontaneously; or, if wanted in a hurry, can be dried over a spirit flame.

"With a properly made emulsion, slides absolutely free from any suspicion of veil in the highlights should be readily procured. Sometimes a slight opalescence is observable, which disappears if the slide is varnished. Should any veil be apparent after fixing, it may readily be removed by flowing over the slide before washing a weak solution of potassium ferricyanide (about $1\frac{1}{2}$ grains to the ounce), sufficient hyposulphite remaining in the film to effect the removal of the fog."

The Carbon Process.— Before passing on to the methods of toning lantern slides, we must deal with the carbon process, which will yield slides in various colors according to the color of the carbon tissue selected. Carbon printing requires daylight, or an open arc lamp. It is not sensitive enough for average artificial light, and the use of the enclosed arc leads to flat results unless negatives of enormous contrast are produced. On the whole, we recommend daylight. Special transparency tissue is made in a warm black, and this contains a very fine pigment, giving an image which is entirely free from any grainy or gritty tendency. The quantity of pigment also is rather in excess of what is used for paper print purposes. Possibly manufacturers would supply a band of tissue in any color with extra pigment in it, but no one but a trade worker would be likely to require so large a quantity.

Owing to the fact that the best results can only be obtained from negatives a good deal stronger than are

ordinarily made, the process is likely to be most useful in those cases where negatives of small size are specially taken for slide making, where originals — such as works of art, famous pictures, etc.— are copied specially, and where controlled prints are made from larger negatives and then copied as we have previously suggested. Given a supply of such negatives, carbon slides may be turned out fairly rapidly; that is, working on a commercial scale a good carbon printer should readily expose and develop from 400 to 600 slides in a day. This could only be done by working 4 or 6 negatives together in a frame, and developing the exposed piece of tissue on a large sheet of glass subsequently cut up to lantern-slide size. Probably this is the handiest method of working even in small quantities, though the negatives may be exposed singly and the tissue developed on glasses $3\frac{1}{4} \times 4$ straight away. Many slide makers, however, get into touch with others and exchange slides, and so it often happens that three or four slides are required from the same negative.

Suppose thin, good quality glass is cut to $6\frac{1}{2} \times 8$, which will give four slides, the tissue must be cut a shade smaller, say $6\frac{1}{4} \times 7\frac{3}{4}$, to allow for expansion when soaking and laying down on the glass. The four negatives should be equal in density, though they may sometimes be equalized by using *papier minerale* in the way practised in the old albumenized paper view printing days. At all events, the four negatives ought to print evenly together, for anything in the way of local development is not feasible. They should be safe-edged carefully *on the glass side*, and attached to a sheet of stout glass in a heavy 8 x 10 printing frame. As the sheet of $6\frac{1}{2} \times 8$ glass cuts exactly into the four slides,

54 HOW TO MAKE LANTERN SLIDES

the tissue must be placed on the negatives very accurately and laid down for development as carefully, so that the picture on each slide will be true as to its vertical lines and so on. It should, of course, be cut to the exact size after sensitizing and drying.

Sensitizing the Tissue.—The bath introduced by Henry W. Bennett some years ago is, on the whole, to be preferred to a plain solution of neutralized potassium bichromate. It will be found that the tissue is much less likely to show a veil — fatal in slide work — when sensitized in the Bennett bath; and, though slower in printing, greater contrast is obtained, which is very desirable. The vigor of the negative must be arranged in conjunction with the choice of sensitizing bath. The bath is made up as follows:

BENNETT'S CARBON SENSITIZING BATH

| | |
|--------------------------------|-----------|
| Potassium bichromate | 4 drams |
| Citric acid | 1 dram |
| Water | 25 ounces |

When dissolved, add liquor ammonia (.880) slowly, with frequent shaking of the bottle, till color changes from red to lemon yellow. The quantity required is usually about 3 drams. The tissue is immersed in this, in the usual way, for 2 minutes in hot weather and 3 minutes in cold (*i.e.*, when thermometer is below 55° F.). Then lay coated side down and squeegee lightly on a sheet of clean glass to remove surface moisture, lift off and pin up in the dark and dry as rapidly as possible. Slow, drying in a damp air, or drying in a gas-contaminated air, produces tissue with a veil, that is, an insoluble surface which varies in thickness according to conditions and increases in thickness with age. It is doubtful if any tissue sensitized in the ordinary way is ever quite

free from this thin insoluble surface, usually producing veil in the print or slide, but which still is removed by the mechanical action of the developing water when it is only very slight. The slide maker who uses Bennett's formula, and carefully exposes and develops his tissue within a couple of days of sensitizing, will not have any trouble with veiling.

Preparing the Glass.— It is possible, though not easy, to develop the tissue on plain glass. The use of a gelatine substratum is recommended. The Autotype Co. give the following:

| SUBSTRATUM | |
|--------------------|-----------|
| Hard gelatine..... | 1 ounce |
| Water..... | 50 ounces |

Swell the gelatine, heat to dissolve, and then add 60 grains of potassium bichromate dissolved in 3 ounces of hot water. Have the glass plates thoroughly clean and dry, and pour this solution over them as if varnishing a negative. Dry them and expose to light to render the substratum insoluble. A large number of plates may be prepared and stored, but it is as well to mark the backs by attaching a small bit of gum paper. They should be kept in a grooved box if possible, or with clean tissue paper between if stored in an ordinary plate box.

Printing the Tissue.— Printing should be done in a strong light, but perhaps not in direct sunlight. Probably the best actinometer is another negative of equal thickness and vigor with a piece of Solio behind it. About three successive Solio prints should be made to get sufficient transparency depth, but this must be taken as an approximate guide only. It will be seen that whereas in a print the light passes through the image twice, *i.e.*, once on its way to the surface of the paper

56 HOW TO MAKE LANTERN SLIDES

and again on its way back to the eye, in a transparency it only passes once, and that therefore the print image is very much more attenuated. This may be seen by stripping bits of the film of a gelatine-surfaced print, and explains why tissue for slide purposes needs to be exposed for a longer time.

In laying down the tissue, care must be taken to get it quite square with the edges of the glass. Care must also be exercised to keep from over-soaking it prior to laying it down. It should be laid on the glass before it has *quite* flattened out, so that the residue of absorptive power possessed by the gelatine of the tissue will entirely take up the film of water between the tissue and the substratum on the glass, which film it is impossible to squeegee out or get rid of by any pressure. This point, important in carbon printing of any kind, is doubly so when making slides.

Reticulation, or a frilling of the film producing the effect of a fine network, is likely to occur if the developing water is used at a temperature much above 100° to 110° F., and is much more prevalent when the tissue is a little stale. Fresh tissue and a careful avoidance of over-exposure will prevent trouble arising in these directions.

When development is complete, the plate is rinsed in cold water and set up to dry. Some workers give a 5 per cent alum bath for 5 minutes, but it is difficult to see why this is necessary.

The color of carbon slides will be quite regular provided the negatives are even in quality, but flattish negatives will not yield slides looking the same color as strong ones, although all are printed from the same band of tissue.

The worker should read up the carbon process in some manual devoted to it. The points we mention here are those where rather special care is necessary.

Combination Work.— We shall describe methods of adding skies, this being the form of combination printing most commonly required, but it will be obvious that either of the methods we give may be used according to circumstances when combining a foreground and middle distance, for example, or any other kind of work. In general, however, the addition of a sky is the only form of combination work likely to be attempted, though in many cases the distance, a glimpse of sea, or of distant hills, may be printed in with the sky, being on the sky negative and treated as a part of the sky from the manipulative standpoint. The first method is that of vignetting one part into the other, and is available in most cases where the landscape right up to the skyline is at least a little darker than the sky. If trees or any dark objects project into the sky, the added clouds will be printed over them, but the slight addition to their density is quite immaterial. When there are light objects against the sky, the second method is the most satisfactory, and if proper care is exercised, the masking is practically perfect. Method number one is most easily worked when using the enlarging lantern method, the lantern plate being open and with the image on it readily visible. The second method may be used with the enlarger or when working in the camera. If the sky negative is a film, it can be worked by contact in the printing frame, but the same precision is seldom obtained.

The Vignetting Method.— When one image is being vignettted into the other, the whole secret of success lies

58 HOW TO MAKE LANTERN SLIDES

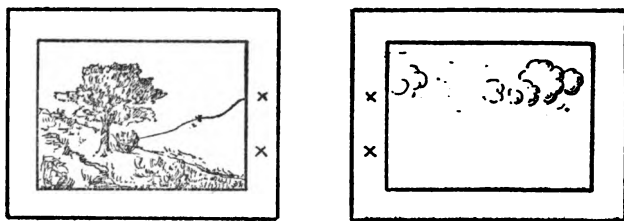

Figure 7

in using a considerable area for the blending. Suppose the size of the picture is $3\frac{1}{2} \times 2\frac{1}{2}$, the piece of black card should be moved between two positions at least half an inch apart, as shown in Figure 7. The edge of the shading card is kept moving between the two crosses, in the one case shading the upper half and in the other case the lower half. The card for shading the sky half of the landscape need not be cut to the outline of the distance, and if it were not for the tree in Figure 7, a straight card edge would answer quite well. In this case, of course, the card would be cut so as to allow the tree to print. If the negative were a strong one, with dense sky, or if the sky were blocked out, it would only be necessary to shade the distant hill very slightly, simply to prevent its being made too dark by the additional depth given when the sky is added. The average negative, however, allows a gray tint to print through the sky, and the shading is necessary to keep the sky portion free from deposit, which would degrade the brilliancy of the clouds. The clouds may be printed on the same plate as the landscape, or they may be printed on another plate which will serve as a cover glass. If on the cover glass, the sky negative must be reversed, of course. Some points regarding the depth of the image and its

color are common to both methods and so will be dealt with in considering the second method.

The Masking Method.— This method is well known to many advanced pictorial workers, and is used not only in slide work, but in the making of transparencies for enlarged negatives. It is undoubtedly the best all-round method of combination printing, and several attempts may be made, if necessary, without any great expense, as small plates may be used. Of course, in slide work the size will be the $3\frac{1}{4} \times 4$. The method, like the vignetting one just described, consists in using two plates in one of which the landscape is printed with a blank sky. This is used as a mask for the other plate upon which the clouds are printed. Then the two are bound up together in exact register, one serving as a cover glass for the other. In this method the sky portion of the landscape picture must be absolutely clear glass, and it is usually better to ensure this by shading or by blocking out the sky with opaque than to adopt any reduction method for removing the veil or deposit. If the subject be one with most of its tones several shades darker than the sky, the properly exposed and developed plate which will be bound up as the slide may be used as the mask; but in some cases where there are many objects light in tone, such as light-colored buildings strongly sunlit, it will be necessary to make a special mask, using another plate and giving a much longer exposure so that even the light buildings will appear dark and so have enough opacity to protect entirely all the landscape area on the sky plate. Sometimes, even on such a fully exposed mask, and usually on the ordinary plate used as a mask, it is necessary to dab opaque on the glass side over any lighter portions,

60 HOW TO MAKE LANTERN SLIDES

but this should never be done up to the skyline, or the perfection of fit will be lost. The sky negative is next placed in the carrier and the position judged best for the clouds is determined. If working in the camera this may be done by holding the mask plate against the $3\frac{1}{4} \times 4$ lines on the focusing ground glass. If working by enlarger, the mask plate is laid against the white focusing plate, and both together are rested on the blanket pins, taking great care that the edges of the plate are accurately coincident. When adjustments have been made, the mask plate is laid, film to film, in contact with an unexposed lantern plate, again taking care to keep the edges coincident, and it is wise to bind the two together with a couple of tiny bits of gummed paper. Then the sky is exposed *through* the clear glass portion of the mask, the landscape part of which effectively shields those portions of the plate from light action. Of course, for this exposure the focusing plate is removed from the easel. If working by camera, the two plates lightly bound together are placed in the dark slide as usual. After exposure the two plates are separated and the sky plate developed, taking care not to over-develop it, a very easy mistake to make. After fixing, washing, and drying, the two plates may again be laid in contact, and the sky and landscape should combine perfectly. Any adjustment of the relative depths by reducing or intensifying should be avoided as far as may be, though occasionally one or the other may be improved by a touch of reducer. But it should be noted that too much reduction of the sky or of the landscape in its lighter tones will often result in the eating away of the edges, so that when the two images are combined a white edging will appear between them, that

is, round the skyline. When binding up the slide it is usually necessary to attach the mask first to the landscape plate with one or two touches of fish glue. Then the sky plate may be adjusted in position, having first had dabs of glue on its margins, and in an hour or so the two will be firmly attached and it will be safe to affix the binding strips.

One difficulty may be found, namely, that of getting the color of the two plates exactly alike. Except for sunset effects, the sky may be a trifle cooler in color without the difference being noticeable. But if the exposures are made with accuracy, and the plates developed with identical developer at the same temperature, there should be little trouble so long as the colors are black and warm-black or brown. In this connection it is well to mention that slight reduction with the potassium ferricyanide reducer will often make the color slightly warmer, while a slide rather too warm may be cooled a little by toning with gold.

As the two plates are separated by the mask (though this is not inevitable, and the mask may be pasted on the outside of the slide), and as plates are never quite flat and therefore never absolutely in contact, some parallax effects may be seen when the slide is examined in the hand, but these will rarely show when the picture is thrown on the screen.

Intensification.— It is sometimes an advantage to be able to modify the strength of a slide. There may be no time to make another slide, or the original negative may be flat and no variation of exposure and development capable of giving sufficient contrast. Or a copy negative may be too soft, and intensifying it may enable slides to be obtained of good quality more readily.

62 HOW TO MAKE LANTERN SLIDES

It should be noted that most methods change the color, some very slightly and others, such as uranium, entirely. Conversely, several toning methods have an intensifying effect. As we have said, we prefer results obtained directly both as to strength and color, and we believe the more expert the slide maker becomes the less he will do in the way of after-treatment. With all methods of intensification *perfect fixation* of the slide is necessary for successful working.

1. **MERCURY.** Dissolve 1 ounce of mercuric chloride in 20 ounces of hot water. When cool, decant and add 20 minims pure hydrochloric acid. Use over and over again for bleaching, until the action becomes too slow. After bleaching the slide, wash thoroughly and reblacken in one of the following:

- (a) 10 per cent solution sodium sulphite, slightly acidified with citric acid. This gives slight additional density.
- (b) Pyro ammonia developer as given on page 15. This gives a brown color to the image.
- (c) Hydrochinon developer as given on page 8.
- (d) Ammonia .880 s.g., 20 drops (or minims) to the ounce of water. This gives considerable extra strength.

2. **CHROMIUM.** This gives much more permanent results and also avoids the use of the poisonous mercuric chloride. The process may be repeated, if it is desired to build up density. Prepare:

| | |
|-----------------------------------|---------------------|
| A. Potassium bichromate | 1 ounce |
| Water | 25 ounces |
| B. Hydrochloric acid | $\frac{1}{2}$ ounce |
| Water | 25 ounces |

Keep these separate until required for use. When required, take equal parts A and B, in quantity sufficient

for the work in hand, and bleach the slide thoroughly. Then wash out the yellow stain, leaving a clean buff-colored image. Then apply a strong amidol developer, which, however, must not contain any bromide.

3. SILVER. This requires a good deal of care in working and the utmost cleanliness. J. B. B. Wellington gives an improved formula as follows:

A preliminary bath of one part of formalin to 10 parts of water, for 5 minutes, is given the negative. This bath may be kept as a stock solution and used over and over again. After a few minutes' rinsing the negative is placed in either of the following for exactly 1 minute, the bichromate being recommended:

| | |
|-----------------------------|-----------|
| Potassium ferricyanide..... | 20 grains |
| Potassium bromide..... | 20 grains |
| Water..... | 20 ounces |

or

| | |
|---------------------------|-----------|
| Potassium bichromate..... | 1 grain |
| Potassium bromide..... | 20 grains |
| Hydrochloric acid..... | 60 minims |
| Water..... | 20 ounces |

Too long an immersion in either of these baths causes the image to bleach, which we wish to avoid if we desire to retain the original gradation. In the time prescribed, there is little apparent change; but the reducing agent has done its work and after a few minutes' rinsing the negative is ready for the intensifying solution.

This intensifier keeps well in stock solution:

| | |
|-------------------------------|--------------|
| A. Silver nitrate..... | 800 grains |
| Water (distilled) to..... | 20 ounces |
| B. Ammonium sulphocyanide.... | 1,400 grains |
| Sodium hyposulphite..... | 1,400 grains |
| Water to..... | 20 ounces |

Half an ounce of B is taken and to it is added $\frac{1}{2}$ ounce of A, stirring vigorously with a glass rod. The

64 HOW TO MAKE LANTERN SLIDES

result should be a clear solution; if the stirring is omitted it is apt to be turbid. To this is added 1 dram of a 10 per cent. solution of pyro preserved with sulphite, and two drams of 10 per cent. ammonia. The negative is laid in a chemically clean dish, and the silver solution poured over it. The deposition of the silver begins to take place in a minute or two, and the image gradually gains in strength. As soon as sufficient density is acquired, the negative is placed in an acid fixing bath, until the slight pyro stain is removed, and is then well washed as usual. It is well to rub the surface of the film with a tuft of absorbent cotton at some time during the washing, to remove a slight surface deposit which will be found upon it. The slide to be intensified by this process must have been thoroughly fixed in a clean, fresh hypo bath, and not merely have been left for some indefinite period in a stale or dirty solution of hypo that has been used on other occasions. The dishes must also be perfectly clean.

4. URANIUM. This gives a red image and is therefore often used as a toning agent. Prepare:

| | |
|--------------------------------|-----------|
| A. Uranium nitrate..... | 25 grains |
| Water..... | 3 ounces |
| B. Potassium ferricyanide..... | 25 grains |
| Water..... | 3 ounces |

For use, mix A and B in equal parts, and add 1 dram of glacial acetic acid for each ounce of the mixture. Be very sure the slide is free from hypo, rock in the bath till density, or color, or both are correct. Then rinse for a moment and wash in several changes of *still* water till yellow stain is gone. Running water gives uneven results. This intensification, and color, may be removed by a weak solution of ammonia or sodium carbonate

(not *bi*-carbonate). If the slide is to be intensified again, give five minutes in weak acetic acid to neutralize the acid, and then rinse.

5. **LEAD.** This is for line subjects where great opacity is desired, and is principally useful on the negatives from which line slides are to be printed.

| | |
|----------------------------------|-----------|
| Lead nitrate | 20 grains |
| Potassium ferricyanide | 30 grains |
| Acetic acid | 10 minims |
| Water | 1 ounce |

Keep in the dark. Bleach the negative in this, and then clear in 10 per cent. nitric acid. The film is now very tender and will readily disintegrate. Then wash in water and finally blacken in

| | |
|---|----------|
| Commercial (yellow fluid) ammonium sulphide | 1 part |
| Water | 15 parts |

or in

| | |
|----------------------------|-----------|
| Schlippe's salts | 45 grains |
| Ammonia (.880) | 3 drams |
| Water | 10 ounces |

In hot weather keep the whole of the solutions and wash waters as cool as possible (say 50° F.) by the aid of ice.

Reduction.— The most generally useful is the hypo and ferricyanide prepared in two solutions, though it is sometimes inclined slightly to alter the color of a slide. A reducer which does not affect the color is iodine and potassium cyanide, but this involves the use of a deadly poison and if possible should be avoided.

1. **HYP0 AND FERRICYANIDE.** Prepare:

| | |
|-------------------------------------|-----------|
| A. Hyposulphite of soda | 1 ounce |
| Water to | 10 ounces |
| B. Potassium ferricyanide | 1 ounce |
| Water to | 10 ounces |

Take sufficient of A for the work immediately at hand

and add a few drops of B, just enough to give a pale yellow color to the mixture. Apply to the slide in a white dish, so that the effect may be seen readily. Sometimes it is preferable to mop the reducer over the slide, or part of it, with a tuft of absorbent cotton. Too strong a reducer, or too long use of the mixture, will produce stains. The use of dirty hypo fixing bath will result in stains. If an acid fixing bath is used, this must be washed out of the film before any attempt is made to reduce.

For line slides the mixture may be used with more of the ferricyanide in it. This "cuts" out any veil on the lines almost at once.

2. IODINE AND POTASSIUM CYANIDE.

| | |
|-------------------------------|---------------|
| A. Potassium iodide..... | 40 grains |
| Iodine..... | 40 grains |
| Water..... | 1 ounce |
| B. Potassium cyanide..... | 40 grains |
| Water..... | 1 ounce |

Take 30 minims of A, 5 minims of B, and 1 ounce of water. This leaves no stain and does not alter the color of the image.

Clearing Bath.— Clearing should not be necessary if due care has been exercised at all stages of the work, but sometimes a slide may be cleared instead of being reduced if it is almost right. The following formula, given by B. J. Edwards, may be useful:

| | |
|---|--------------|
| A. Alum..... | 1 ounce |
| Citric acid..... | 1 ounce |
| Water..... | 15 ounces |
| B. Saturated solution of iron sulphate..... | 5 ounces |

Take for use, 1 part of B and 3 parts of A. A used alone has a slight reducing action on the slide.

Toning Slides.— Toning methods may be divided roughly into two groups — those which aim at the production of a totally different color, and those which may be employed to “cool” the color of a slide which is too warm. The latter use of toning is often advantageous in combination work, gold usually being employed.

1. **GOLD.** Combined bath for use directly after development.

| | |
|----------------------------------|-----------------------|
| Water | 6 ounces |
| Ammonium sulphocyanide | $\frac{1}{4}$ ounce |
| Hypo | $2\frac{1}{2}$ ounces |

When dissolved, add 4 grains of gold chloride in 4 ounces of water, and allow the bath to stand a day or two to ripen.

Separate gold bath for use after fixing and washing:

| | |
|-------------------------------------|-----------------------|
| A. Gold chloride | 15 grains |
| Distilled water | $7\frac{1}{2}$ ounces |
| B. Ammonium sulphocyanide | 40 grains |
| Water | 4 ounces |

To use, take 1 part of A and 4 parts of B. This bath will give blue-black and blue tones if toning is carried far enough.

RED TONES. (a) Use uranium, as under intensification. (b) Bleach the slide in:

| | |
|----------------------------------|-----------|
| Potassium bromide | 1 ounce |
| Potassium ferricyanide | 1 ounce |
| Water | 20 ounces |

Wash out the yellow stain, and redevelop in:

| | |
|---------------------------|---------------------|
| Schlippe's salt | $\frac{1}{2}$ ounce |
| Water | 10 ounces |

If instead of this the following is used, the color is a warm sepia with most plates:

| | |
|--------------------------------|---------------------|
| Pure sodium sulphide | $\frac{1}{2}$ ounce |
| Water | 10 ounces |

68 HOW TO MAKE LANTERN SLIDES

By mixing the two solutions in various proportions, intermediate colors may be obtained, but not with much certainty.

(c) *Copper toning.* This will give a red only if toning is pushed as far as possible. Shorter toning will give fine warm blacks, but the action must be stopped at the right moment.

| | | |
|----|-------------------------------------|------------|
| A. | Copper sulphate | 30 grains |
| | Neutral potassium citrate | 120 grains |
| | Water | 10 ounces |
| B. | Potassium ferricyanide | 25 grains |
| | Natural potassium citrate | 120 grains |
| | Water | 10 ounces |

Take equal parts of A and B, and an equal volume of water. The color changes slowly, and toning is best done in daylight as the color can then be judged better. Copper toning does not intensify.

BLUE TONES. This toning intensifies the slide. Prepare:

- A. 10 per cent. solution of ferric ammonium citrate.
- B. 10 per cent. solution of potassium ferricyanide.
- C. 10 per cent. solution of glacial acetic acid.

For toning, take half an ounce each of A and B, and 5 ounces of C. The slide must be thoroughly well washed to free it from hypo. Then immerse in the toning bath till the desired depth of color is obtained, and wash until the highlights are clear.

GREEN TONES. These may be obtained with vanadium as follows:

| | |
|--|-----------|
| Ferric chloride | 1 grain |
| Oxalic acid (saturated solution) | 60 minims |
| Vanadium chloride (pure) | 2 grains |
| Nitric acid | 5 minims |
| Water to | ½ ounce |

Then add, stirring the while:

| | |
|-----------------------------|---------|
| Potassium ferricyanide..... | 1 grain |
| Water to..... | ½ ounce |

Tone for from one to two minutes; the longer the toning the lighter the green. Wash for ten minutes, and then give a minute in the following hypo bath:

| | |
|-----------------|------------|
| Hypo..... | 2 ounces |
| Boric acid..... | 200 grains |
| Water to..... | 10 ounces |

Then wash for ten minutes.

BROWN TONES. These may be obtained by uranium, stopping sooner than for red tones; or by bleaching and redeveloping with sodium sulphide, both of which are given under red tones. Welborne Piper's method of haloid toning also gives brown tones. The slide is bleached in the potassium bichromate — hydrochloric acid bleacher as given under chromium intensification. Then rinse, place in 2 per cent. solution of potassium metabisulphite until the yellow stain is gone, wash and dry. Then expose to bright daylight for a day or two.

By a slight modification in the bleacher, brown tones may be had. Bleach in:

| | |
|---------------------------|-----------|
| Potassium bichromate..... | 10 grains |
| Potassium iodide..... | 5 grains |
| Nitric acid..... | 5 drops |
| Water..... | 1 ounce |

The treatment after bleaching is the same as before.

Finishing the Slide.— When all the required chemical processes have been completed, the slide is ready for varnishing and binding up. The varnish we prefer is a crystal positive varnish applied hot, but many workers prefer a cold varnish consisting of gum dammar dissolved in benzol. Our preference for the other varnish

is on account of its requiring the plate to be heated which ensures driving off all moisture from the gelatine film. Collodio-bromide slides do not need varnishing to protect them from moisture, but it is well to do so, taking care that the solvent of the varnish is not likely to dissolve the collodion film. A rack of slides may be placed in front of the fire where they will get thoroughly dried; yet not too hot to be comfortable if one be laid against the back of the hand. The varnish must be filtered through a good filter paper, and care taken that it is not too thick or it will produce streaky marks which will show on the screen. The bottle should be a "good pourer," as old ladies say of a teapot, and not more than half full. Varnishing is done just as with negatives. After varnishing, the slide should be returned to the rack and heated for an hour.

Retouching.— There should be nothing to retouch, but occasionally a tiny white speck may be seen, and each slide should be examined on the retouching desk and any such spots touched out with a hard pencil made needle-point sharp. Actually, a magnifying glass should be used to make sure of touching exactly the right place. Some workers may prefer to use a fine sable brush and water color. It may be noted that in spotting slides other than black the rule is: Have the color rather colder than the color of the slide. Thus, India ink on a sepia slide will not show, whereas sepia on a warm black slide would show badly. If a spot is spoiled, the paint may be removed with a clean moist brush, and a fresh start made. This is another reason for having the slide varnished.

Masking.— Commercial slides will be masked with masks of standard sizes. For special subjects, how-

ever, the keen worker will wish to cut his own masks, just as he trims his pictorial prints, in proportions and sizes to please himself. Masks may readily be cut from black paper, using a very sharp knife, and cutting on a sheet of strawboard. The corners of the opening must be cut clean, cutting up to the corner but not beyond it.

Titling.— This may be done by writing on the black paper mask with Johnston's Snow White, or white ink prepared as follows:

| | |
|------------------------|---|
| Picked gum arabic..... | 4 parts |
| Water..... | 120 parts |
| Zinc oxide..... | Add enough to give a brilliant white |

Or when one side of the mask is white, titling may be done in black ink. The title is best on the mask, as, if attached to the outside of the glass, it may come off and the identity of the slide be lost.

Binding.— This is the bugbear of the beginner. Girls in the trade houses will bind slides with incredible rapidity. To begin with, the easiest method is to put the binding strips on in pieces, cutting them a shade shorter than 4 inches or $3\frac{1}{4}$ inches. Though coated with an adhesive, they will stick better if moistened with Higgins' paste. Lay a strip down on a blotting pad, sticky side up, press slide and cover glass tightly together in the left hand, then take hold of it across the $3\frac{1}{4}$ inch width with the thumb of the right hand on one edge, the first finger on the end, and the other three fingers on the other edge. Press the bottom edge on to the pasted strip, *and press firmly*, so that the strip adheres to the edges of the two glasses. This is very important if permanent binding is desired. After pressing for a few seconds, grip the middle of the slide with the fingers and thumb of the left hand; turn it the other

way up, and then fold over the strip, pressing its edges down onto the sides of the slide. This folding over and pressing down is done with finger and thumb of the right hand. Repeat the process with the other end and then proceed to the sides. The essential points are:

- (a) The two glasses must be kept tightly together.
- (b) The binding strip must adhere to the *edges* of the slide.
- (c) The edges of the strip must stick firmly to the sides of the slide.

Pasting the strip has the advantage that it does not dry so quickly as moistened gum or dextrine, but too much paste should not be used, or the subsequent cleaning of the slide will be troublesome.

Waste plates form excellent cover glasses if the films are cleaned off in hot water, but cover glasses may be bought clean and ready for the final polish prior to use. For this polishing it is convenient to have a holder made by cutting a $3\frac{1}{4}$ inch x 4 inch hole in a sheet of strawboard, with a little thumb-hole at one end — a sort of semi-circular notch. This card is glued down on another sheet of stouter strawboard and kept under pressure till dry. The cover glass is laid down in the tray (just as a plate is laid in its "carrier") and may then be polished very thoroughly with a duster folded up into a pad or ball.

Spotting.— This is the final operation, and the spots are an indication to the lantern operator as to the position the slide must occupy in the lantern carrier. The way to fix them is to hold the slide up so that the picture appears the correct way on, and then to attach two little white patches or spots to the two top corners, just off the binding strip if possible, without encroaching on

the picture. The lanternist places the slide in the carrier upside down, with these spots towards the condenser, which usually means towards himself also.

MISCELLANEA

Plates for Diagram Slides.— Opaque plates on which diagram slides may be made are convenient to the lecturer and teacher. A fogged and developed lantern plate may be used, the diagram being drawn with an etcher's needle which will cut through the film to the glass.

Or, clean glasses may be coated with bitumen dissolved in benzol (not benzine), or, better still, toluol, and the drawing made in the same way.

Or, celluloid varnish stained with green or brown aniline dye may be used, again etching with the needle.

A fixed out, washed, and dried lantern plate may be used, drawing on it with India ink and an ordinary fine pen. The film should be washed over with prepared ox-gall to make the ink flow freely.

Coloring Lantern Slides.— The easiest method is to use transparent oil colors on the gelatine film. The colors are mixed with a little turpentine and mastic varnish. Drying is slow unless the slides are put in an oven to dry. Always work by daylight or by a light the same color as that which will be used in the lantern. Work with water-color brushes — sables, if possible. Judge colors by transmitted light, using a glass palette. The following colors are good and may be obtained in collapsible tubes. *Blues* — Prussian (d); indigo (d); Antwerp; French ultramarine. *Yellows* — Italian pink (d); yellow lake (d); *Browns* — Burnt sienna (d).

Reds—Crimson lake (d); madder lake. *Blacks*—Ivory black (d). The (d) means that the color has enough body to admit of dabbing, while the others are for brush work only. Prussian blue is useful for skies, and mixed with Italian pink gives a good green. Crimson lake and Italian pink give a good scarlet. Burnt sienna and Prussian blue give an olive-green for shadows in foliage.

For small areas the colors are laid on with a brush. Large areas are dabbed. The dabber is a short thin stick on the end of which is a tuft of cotton wool with a bit of kid glove tied tightly round. The color is applied with a brush and evened by dabbing, using the dabber like a light hammer and tapping over the required area.

Skies are the most difficult. Usually a little crimson lake or Italian pink may be used near the horizon and Prussian blue at the upper part, the two being blended with the dabber. When this can be done deftly, clouds may be inserted. Cut a penholder to a wedge shape, and stretch over it a piece of kid glove. This is the wiper, and with it the paint dabbed on the sky may be removed to give the effect of a white cloud. Cumulus clouds require the wiper to be used broadways, but stratus clouds may be produced by wiping edgeways and softening the line so made by dabbing gently. This wiper is also handy for cleaning up buildings which project into the sky and have been covered by the dabbing.

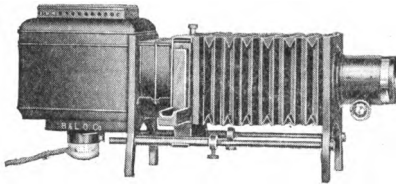

*Having transformed
your prints into lan-
tern slides the most
satisfactory means
of projecting them is
with a*

Bausch^{and} Lomb **BALOPTICON** THE PERFECT STEREOPTICON

Model B, here illustrated, is particularly adaptable to your purpose. It is compact, easily portable and moderate priced, yet — like all Bausch & Lomb products — optically and mechanically correct. Now equipped with new 400-watt, gas-filled Mazda Lamp, which gives much better illumination than the corresponding arc lamp on alternating current, and at less current expense. Besides, it is absolutely automatic in operation. You simply attach it to a lamp socket, turn the switch, and it runs itself. Can also be supplied with acetylene burner, when electricity is not available. **Price, \$26.50 up.**

Home Balopticon, for photo prints, post cards and other opaque objects, **\$35.00**; Combination model, for both forms of projection, **\$45.00.**

Write for illustrated circulars

Bausch & Lomb Optical Co.

NEW YORK WASHINGTON CHICAGO SAN FRANCISCO
LONDON ROCHESTER, N.Y. FRANKFORT

*Leading American Makers of Microscopes, Projection Lanterns
(Balopticons), Photographic and Ophthalmic Lenses, Bi-
noculars and other High-Grade Optical Products*

Please mention Practical Photography when writing Advertisers

Concerning

PRACTICAL PHOTOGRAPHY

From the Publisher to the Reader

THIS number of **Practical Photography** shows the aim of the Editors in publishing the series — to give in each volume the practical information needed to master a definite branch of photographic work. Useless, impractical theories are not included, the whole purport of the series being to give up-to-date, usable information that will be immediately helpful in the field or workroom. Illustrations are used wherever necessary to make the text entirely clear but not solely because of their artistic value. Whether in paper or cloth binding, the size will be uniform — handily fitting the pocket. In paper, per copy, twenty-five cents, or \$2.50 by subscription for twelve numbers. In cloth, per copy, fifty cents, or \$5.00 by subscription for twelve numbers.

No. 1. The Secret of Exposure. If exposure is correct, all other steps in the making of a good negative are purely mechanical. This number discusses exposure thoroughly and gives a complete system, with full directions, for obtaining correct exposure under all conditions, using any plate on the American market. Concluding with a clear discussion of the use of exposure meters, it is the most complete treatise on the subject ever written.

No. 2. Beginners' Troubles. This number contains an enormous amount of practical help for every worker, novice, or expert. Its primary purpose is to show the cause of common failures, but in general it is a manual of photographic work dealing with the production of a perfect negative and a print from it.

No. 3. How to Choose and Use a Lens. Every successful worker must know what his lens can do and how it may be used to best advantage. *He must.* This number explains the particular qualities of each type of lens now used in photography and deals particularly with the more modern types their differences and relative advantages. It not only answers the questions that the practical worker will ask, but it is recommended for the careful study of the man who is about to purchase a high-grade outfit and must understand the lens question if an intelligent choice is to be made.

No. 4. How to Make Prints in Colors. The desirability of making prints in colors led to the publishing of this number, a careful choice of the best methods being made for the guidance of our readers. The toning of a standard black and white print to every possible hue is explained, while the special manipulating processes and the latest developments in natural color photography are clearly described.

No. 5. How to Make Enlargements. No worker who advances beyond the plane of the tyro can produce consistently satisfying results without an enlarger. This volume tells the why of the enlarging process, and follows it with full and clear information regarding the practical side of enlarging, including the construction and use of different types of enlargers.

No. 6. How to Make Portraits. Making portraits in the home is a branch of photography of interest to every owner of a camera. This volume tells in detail how to make portraits of your family and friends, which will be more satisfactory to you than the conventional portrait made in a studio. You need no other source of information than this book to make portraits of any size, by contact or enlarging methods.

No. 7. How to Make Lantern Slides. An exhibit of slides from your own negatives is a treat for your family and friends. In this volume the subject of slide making is thoroughly covered. Slides in black and white, toned, or in natural colors can be made by any camera user. A copy of this book will tell you how to make them.

The books of this series may be had from dealers in photographic supplies, news stands, booksellers, or the publishers.

American Photographic Publishing Co.

221 Columbus Avenue

Boston, Mass.

Please mention **Practical Photography** when writing Advertisers

Lantern Slides
of
Exceptional Beauty
on
CENTRAL PLATES

HARD
BLACK

SEPATONE
SOFT

SOFT
BLACK

CENTRAL DRY PLATE CO.
ST. LOUIS, MO.

CHANGE THE SLIDES

That's all there is to "operating"

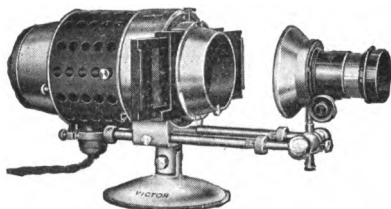

**THE VICTOR
PORTABLE
STEREOPTICON**

The original Victor features that a few years ago made possible the popular use of lantern slides, have been further improved. The same solid cast aluminum construction is used. Service and genuine satisfaction is guaranteed.

Write today for information on the variations of lenses and lamps that provide for every need.

Ask for "trial - before - purchase" terms.

Victor Animatograph Company

195 Victor Building
Davenport, Iowa, U.S.A.

Please mention Practical Photography when writing Advertisers

The Central Dry Plate Company

Announce their removal to their new fully equipped modern factory. Built for and devoted exclusively to the manufacture of

Standardized Photographic Plates

for Amateur, Professional, and Commercial Workers.

CENTRAL DRY PLATE COMPANY
BENAVIS, ST. LOUIS, MO.

Two Dimes Well Spent

Two practical little handbooks, just the kind you like to keep handy in the darkroom for reference when you need a special formula or help with a puzzling point in the making of a negative or print.

PRACTICAL DEVELOPMENT

HOW TO MAKE GOOD PRINTS

Each, one dime. And they are dime savers, too!

Our stock of these is running low. As you know, this series is being discontinued and there will be no reprints. Send us two dimes — while your money is good.

American Photographic Publishing Co.
221 Columbus Ave. Boston, Mass.

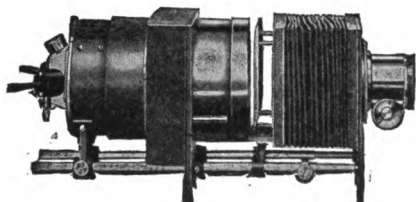

*"McIntosh Lanterns
are
Honest Lanterns"*

THIS IS THE SEASON

to make lantern slides of your good negatives and show them on the screen, life size, sharp, clear, vivid — projected by a sturdy McIntosh Lantern. (It can be used for enlarging, too, from the smaller negatives.)

YOUR FAMILY AND FRIENDS

will appreciate your pictures much more if they do not need to strain their eyes and crane their necks to see them. Slides are as easy to make as paper prints and heaps more fun.

McINTOSH STEREOPTICON COMPANY
460 ATLAS BLOCK - - - CHICAGO

**Write For This
1918 Camera
Catalog Today**

**The Book That
Chased Waste Out
of Camera Buying**

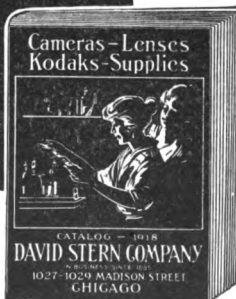

Please mention Practical Photography when writing Advertisers

The Alpha and Omega of Negative Making

IN THE BEGINNING

the exposure must be full, sufficiently so to produce detail in the shadows, and yet not exceeding the limit allowed by the latitude of the plate. A reliable exposure table such as the

AMERICAN PHOTOGRAPHY EXPOSURE TABLES

will enable you to correctly expose any plate or film on the American market, any time, any place, on any subject. It is a complete vest pocket book — one-eighth inch thick — giving, beside the tables, a complete treatise on exposure, and pages for making a record of exposures. Start the negative right; use the Tables.

IN THE END

you will stand no chance of spoiling a perfectly exposed negative, if you will develop it by the Thermo method, in which the strength and temperature of the developer, and the brand of plate or film, determine the length of time that should be allowed for development. This information is given on the

THERMO DEVELOPMENT CHART

which gives formulae, and time and temperature factors for developing all the plates and films listed in the Tables. Finish the plate right. The combination of Exposure Tables and Development Chart is the alpha and omega of negative making — you can make a perfect negative with every plate or film. The Tables, the Chart, price 25c each, from

American Photographic Publishing Co.
221 Columbus Ave. Boston, Mass.

Please mention Practical Photography when writing Advertisers

No photographic
equipment is
complete
without a

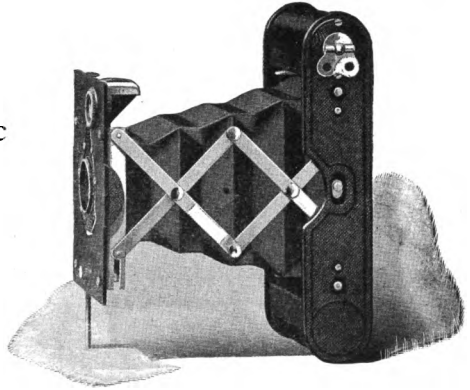

Vest Pocket Autographic Kodak

So small and compact that it fits pocket or handbag, the V. P. K. may always be carried where a larger Kodak might be an inconvenience.

So mechanically and photographically *right*, that good results follow as a matter of course.

Your dealer has the Vest Pocket Autographic Kodak at \$6.00 or with anastigmat lens at \$10.00.

EASTMAN KODAK COMPANY,
ROCHESTER, N. Y., *The Kodak City.*

Please mention Practical Photography when writing Advertisers

"The experience is in the tank."

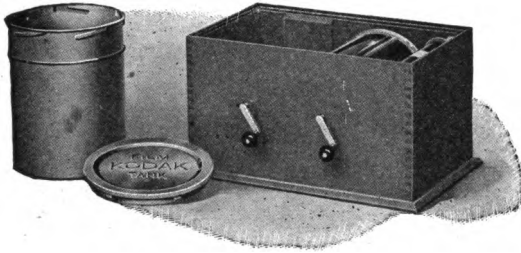

Day in and day out, the

Kodak Film Tank

will yield you fog-free negatives
possessing a snap and brilliancy
only possible in tank development.

No dark-room—daylight all the way.

EASTMAN KODAK COMPANY,
ROCHESTER, N. Y.

At your dealer's.

Please mention Practical Photography when writing Advertisers

With Eastman Flash Sheets and the

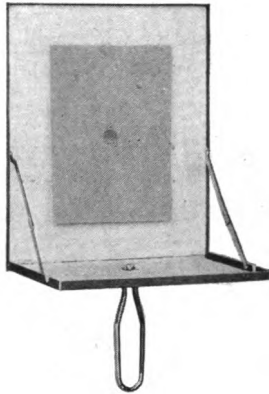

Kodak Flash Sheet Holder

the amateur is well equipped for successful flash light work. The flash sheets burn slowly giving a broad, soft light and the holder adds the element of convenience, allowing the amateur absolute control over his illumination.

The Kodak Flash Sheet Holder is of light metal and is provided with a saw tooth for holding the flash sheet in position. The sheet is ignited from the back of the holder so that a metal sheath protects the operator from the flash.

The price of the Kodak Flash Sheet Holder is \$1.00.

**EASTMAN KODAK COMPANY,
ROCHESTER, N. Y.**

At your dealer's.

Please mention Practical Photography when writing Advertisers

Digitized by Google

Keep a Photographic Diary

Pictures tell volumes in themselves and the autographic negatives make the record authentic.

Here are two albums either of which will most satisfactorily answer every requirement for a book of this kind.



The KODAK ALBUM

The prints are not pasted in but slipped in, pocket strips at the top and bottom of each page being provided for this purpose. Handsome grain leather cover and black leaves with linen finish.

The price ranges from \$2.25 to \$3.50 according to style and size.

The INTERCHANGE ALBUM

is an unusually long-lived album on the loose leaf principle. New leaves can be added as necessary. A special embossed leather cover with grain leather corners and back make it a real ornament to any library table.

The price ranges from \$2.50 to \$5.00 according to size and style.

EASTMAN KODAK COMPANY,
ROCHESTER, N. Y.

At your dealer's.

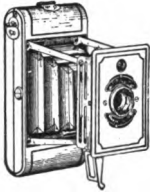

You can get a

**GRAFLEX—KODAK—
REXO—ANSCO—PREMO
OR SENECA CAMERA,
LENSES AND SUPPLIES**

of every description, new or used, at great saving prices. 3A Eastman

Folding Pocket Kodak, \$11.75; 1A Eastman Folding Pocket Kodak R.R. Type, \$9.25; 3A Compact Graflex, 5 x 7 Ic Tessar *f*:4.5 Lens, \$89.75. Send at once for our free

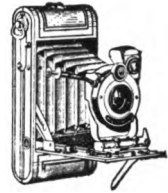

BARGAIN BOOK AND CATALOGUE

and convince yourself. We list hundreds of bargains. Thousands have been more than satisfied—we know we can please you, if given a trial. Every item listed is sold on our

TEN-DAY FREE TRIAL GUARANTEE

or money back in full if unsatisfactory. If you desire to exchange your outfit for some other, consult us. In business for past 18 years.

Central Camera Co.

Dept. AA1
124 So. Wabash Ave.
CHICAGO, ILLINOIS

LANTERN SLIDE MATS

TEN OPENINGS.

Samples and prices upon request

SIERRA PUBLISHING CO.

P.O. Box No. 3, Cranford, N.J.

Pictorial Landscape Photography

By **JOHN A. HODGES, F.R.P.S.**

Here is a useful book that gives the principles of landscape photography in a nutshell. The chances are that after reading it, you can study your pictures and make them more artistic by selective treatment. The illustrations will give you some standard by which you can judge your own efforts to see where they can be improved.

Bound in paper covers, 25c.

American Photography Company

221 Columbus Ave.

Boston, Mass.

Please mention Practical Photography when writing Advertisers

CHEMISTRY FOR PHOTOGRAPHERS

WM. R. FLINT.

As soon as the purely mechanical processes of making prints by contact and enlarging methods have been mastered, the photographer who is ambitious looks about him for new methods and mediums. It is safe to say that his success will be of a mediocre degree unless he understands the chemical laws and reactions which govern the processes by which a permanent image is produced on the photographic medium with which he is working.

The author of this volume is an expert photographic chemist. He has developed a logical series of experiments which cover the chemical reactions that take place in producing negative and print on all kinds of mediums. The reader who follows the experiments carefully — either actually conducting them or else studying the reactions given by the author — will have a thorough knowledge of the underlying chemical principles which govern all photographic processes. He will be in a position to work intelligently in any medium, and to conduct experimental photographic work.

The volume is a comprehensive treatise on photography from a chemical standpoint, but is complete with formulae for standard photographic solutions and emulsions, which are given at the same time as the chemical experiments so that their relation can be easily understood. The appendix is unusually informative, a large number of useful tables being added. The cross index is extensive.

Bound in red cloth; lettered in gold; two hundred pages. Price, \$2.00. For sale by

American Photographic Publishing Co.
221 Columbus Ave. Boston, Mass.

Please mention Practical Photography when writing Advertisers

Your Success In

PHOTOGRAPHY

EVERY reader of this volume is seriously interested in the success of his photographic efforts. Of this we feel assured — otherwise he would not have purchased this book to secure information that brings successful results. Information! That is the secret of good results — backed by experience. Information must be up-to-date, authentic, and to be valuable the useless facts must be weeded out from the practical “meaty” matter, and the net result presented to the reader. This is what the Editors are doing, not only in this series of books, but in our monthly magazine **AMERICAN PHOTOGRAPHY** as well. For more than twenty-five years this magazine has served the American photographic public, and endeavored to be all that its name implies — the standard American photographic magazine. It covers the whole field of photography, for amateur, professional and commercial workers, publishing each month forceful articles on the best current practice and latest advances in each of these classifications. The monthly departments include two monthly Competitions, with criticism of pictures; “Shop Notes;” “Exchange List,” for the exchange of prints; “Readers’ Forum,” for the general correspondence of readers; “The Market Place,” listing the most recent information as to firms buying pictures; “Notes and News” of clubs, new material, books and manufacturing activities. In short, we publish a readers’ magazine, and in addition place our Editorial Staff at the service of our friends, to help them with perplexing problems. This means you!

Does a magazine published along such lines meet your ideas of good service? We think it does, for we try to put ourselves in our readers’ positions when we consider a change in the makeup of the magazine. Join our steadily increasing circle of readers and friends. The subscription price is but \$2.00 per year, including personal Editorial help when you need it. Send your subscription today and look forward to twelve numbers of the best photographic literature that you have ever read.

American Photographic Publishing Co.
221 Columbus Avenue **Boston, Mass.**

Please mention *Practical Photography* when writing Advertisers

Optics for Photographers

Translated from the German of
HANS HARTING, Ph.D.
By **FRANK R. FRAPRIE, S.M., F.R.P.S.**

The writer of this book starts with the fundamental laws of the propagation of light, and carefully and logically carries the reader through the principles of geometrical optics to a complete explanation of the action of all types of photographic lenses, and a description of their qualities and defects. Only the simplest mathematics is used, and this sparingly. The book is brilliantly worked out and is indispensable in the photographic library, being the only modern and comprehensive work on the subject in English. The author is the calculator and inventor of a well-known series of high grade anastigmat lenses; he has the happy faculty of expressing himself in such clear, simple language that no one will have the least difficulty in understanding his exposition of the subject.

**220 pages, bound in red cloth,
numerous illustrations, \$2.00**

American Photographic Publishing Co.
221 Columbus Ave. Boston, Mass.

Please mention Practical Photography when writing Advertisers

89099358327



B89099358327A

**TRANSFERRED TO
MEMORIAL LIBRARY
STACKS**

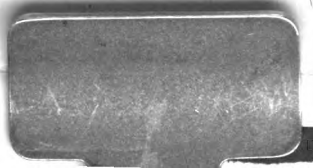
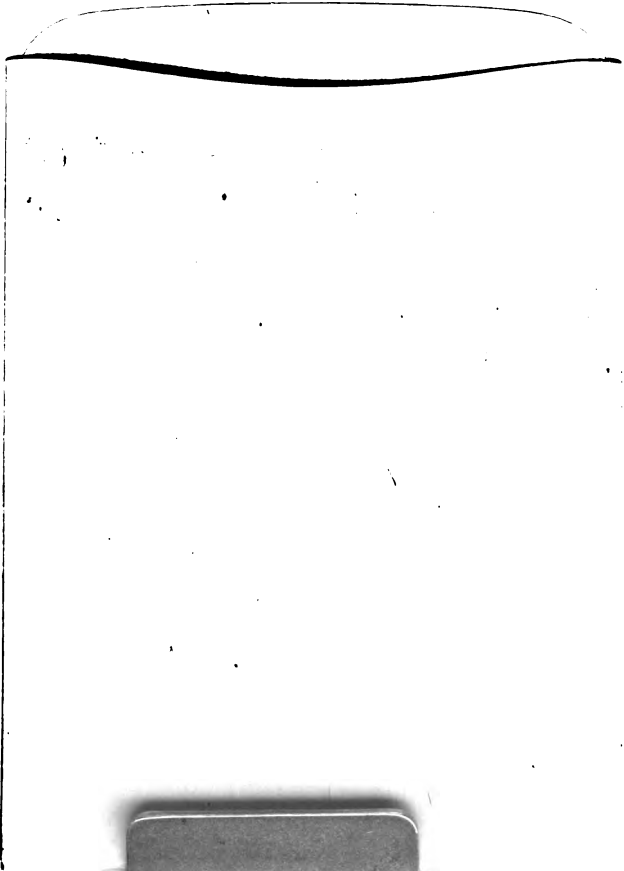

89099358327



b89099358327a