

T

353

.T52

SENIOR COURSE  
IN  
MECHANICAL DRAWING

---

THORNE









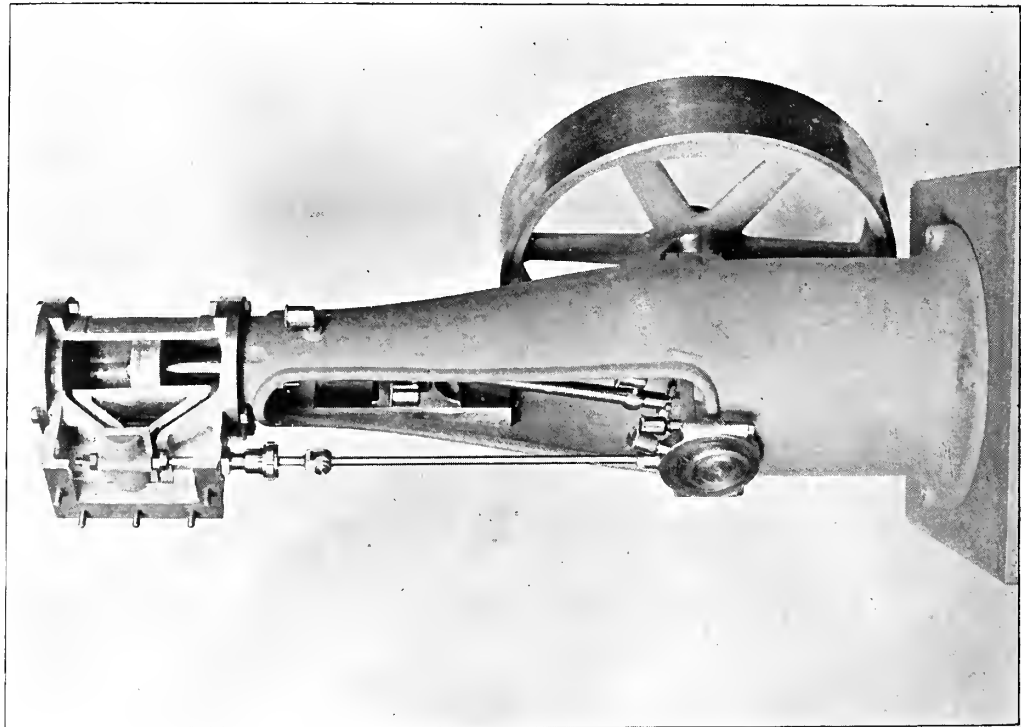

# SENIOR COURSE

IN

# MECHANICAL DRAWING,

COMPRISING

A Complete System of Working Drawings,

BY

WILLIAM H. THORNE,

DIRECTOR OF THE DRAWING SCHOOL OF THE FRANKLIN INSTITUTE, PHILADELPHIA,  
MEMBER OF THE AMERICAN SOCIETY OF MECHANICAL ENGINEERS.

---

PUBLISHED BY

WILLIAMS, BROWN & EARLE,

N. E. COR. CHESTNUT AND TENTH STREETS, PHILADELPHIA.

[1897].

L.



51352c22

Entered according to Act of Congress, in the year 1897, by  
WILLIAM H. THORNE,  
In the Office of the Librarian of Congress, at Washington.

T353  
.T52



## PREFACE.

This SENIOR COURSE in Mechanical Drawing is the result of my experience in making and directing the making of drawings for shop use, and in working and directing the work of others from such drawings, combined with that of teaching and superintending the instruction of the drawing classes of the Franklin Institute. It is essentially practical, without neglecting explanations of the principles involved, excepting the dynamical ones, which are beyond its scope.

Engineering-drawing has been selected as the type of mechanical drawing because it has been developed to greater perfection than any other. The working drawings of the steam engine are submitted as a model for shop-drawings, to be modified by special conditions and circumstances. The subject of Gearing has been treated on the basis of actual requirements, without complicating it by abnormal and impractical cases. The system of Involute Gear Teeth is presented with the hope that engineers will give it their thought, and consider the advisability of adopting some one standard for the shapes and proportions of teeth, so that, at some future day, a wheel cut in one establishment will gear properly with any wheel of the same pitch cut in another.

The student, beginning this course, should be impressed with the idea that the way to learn how to draw is to make drawings, and to make them understandingly, accurately, and in so finished a manner that the thing could be constructed from the drawing alone without any verbal explanation, and that anything less than this is not a mechanical drawing.

The Plates are reproductions by photographic process of drawings made in my usual style, in order not to dishearten the student by the delicacy and perfection of line to be found in steel or copper-plate engravings, and characters printed from type.

WM. H. THORNE.

GOWEN AVE., MOUNT AIRY,  
PHILADELPHIA, 1890.

## TABLE OF CONTENTS.

---

	PAGE		PAGE
Introduction, . . . . .	7	Engine Frame, Plate 33, . . . . .	47
List of Plates, . . . . .	6	Construction Drawing of Engine, Plate 34, . . . . .	48
Helix and Helicoid, Plate 21, . . . . .	11	Valve Motion, Plate 35, . . . . .	51
Conventional Representation of Screw-threads, . . . . .	18	Bilgram Valve Diagram, Plate 36, . . . . .	55
Bolts, . . . . .	20	Adjustable Connecting-rod and Eccentric-rod, Plate 37, . . . . .	65
Steam, Gas, and Water-pipe, . . . . .	25	Brass Globe Valve, Plate 38, . . . . .	66
Shop Drawings, . . . . .	26	Toothed Gearing, . . . . .	67
Vertical Engine, . . . . .	27	Involute Gear-teeth, Plate 39, . . . . .	75
Lists of Details, . . . . .	28	Approximate Involute Teeth, Plate 40, . . . . .	81
Bolts and Keys for Engine, Plate 22, . . . . .	32	Diametral Pitch, Plate 41, . . . . .	83
Piston-rod, Valve-rod, Pins and Rings, Plate 23, . . . . .	35	Proportions of Gear-wheels, . . . . .	85
Connecting-rod and Eccentric-rod, Plate 24, . . . . .	36	Cycloidal Gear-teeth, Plate 42, . . . . .	86
Crank-shaft, Plate 25, . . . . .	37	Bevel Gears, Plate 43, . . . . .	90
Piston, Shaft Brasses, Gland and Bushing, Plate 26, . . . . .	39	Conclusion . . . . .	95
Fly-wheel, Plate 27, . . . . .	40	Table of Decimal Equivalents, . . . . .	96
Slide Valve and Crosshead, Plate 28, . . . . .	41	Standard Proportions for Bolts and Nuts, . . . . .	97
Eccentric and Strap, Plate 29, . . . . .	42	Standard Dimensions of Wrought-iron Pipes, . . . . .	98
Brass Details, Plate 30, . . . . .	43	Table for Proportions of Teeth of Gears, . . . . .	99
Covers and Caps, Plate 31, . . . . .	44	Table for Approximate Shapes of Gear-teeth, . . . . .	100
Steam Cylinder, Plate 32, . . . . .	45	Index, . . . . .	101

## LIST OF PLATES.

---

	NO.		NO.
Helix, Helicoid, and Screw-threads, . . . . .	21	Engine Frame, . . . . .	33
Bolts and Keys, . . . . .	22	Construction Drawing of Engine, . . . . .	34
Piston-rod, Piston-rings, Valve-stem and Pins . . . . .	23	Valve Motion of Engine, . . . . .	35
Connecting-rod and Eccentric-rod, . . . . .	24	Bilgram Valve Diagram, . . . . .	36
Crank-shaft, . . . . .	25	Adjustable Connecting and Eccentric-rods, . . . . .	37
Piston, Gland, Bushing, and Brasses, . . . . .	26	Globe Valve, . . . . .	38
Fly-wheel, . . . . .	27	Involute Gear-teeth, . . . . .	39
Slide Valve and Crosshead, . . . . .	28	Approximate Involute Gear-teeth, . . . . .	40
Eccentric and Strap, . . . . .	29	Proportions for Gear-wheels, . . . . .	41
Brass Details, . . . . .	30	Cycloidal Gear-teeth, . . . . .	42
Covers and Caps, . . . . .	31	Bevel Gear-wheels, . . . . .	43
Cylinder, . . . . .	32		

## INTRODUCTION.

If the preceding Junior and Intermediate Courses have been understood and the drawings correctly made, the geometry and technicalities and the principles of projection should, by this time, be so familiar to the student as to render unnecessary any very detailed directions in relation to them.

The same outfit of tools and materials will be sufficient for this course, except that the  $5\frac{1}{2}$ " Compasses with the lengthening-bar will not describe an arc of much more than 12" radius, which is not sufficient for some of the examples of gearing. If Beam-Compasses are not available, these examples should be drawn to a reduced scale to bring them within the capacity of the  $5\frac{1}{2}$ " compasses.

### SCALES.

The use of different *scales* will now become an item of more importance, and a correct conception and manipulation of them at the start will prevent much of the awkwardness and loss of time so commonly seen in their handling. A full-size scale

is a ruler, graduated to units and fractions of the standard of measurement. In this country the standard is the *foot*, subdivided into 12 *inches*, and each inch is again subdivided into halves, quarters, eighths, and so on. The subdivisions of the inch, on scales for drawing purposes, need not be made smaller than  $\frac{1}{32}$ "', because a sixty-fourth, for instance, can be as accurately laid off half-way between two of the thirty-second marks as if the sixty-fourth mark was on the scale. These subdivisions of the inch, down to  $\frac{1}{32}$ ", should be on every inch throughout the entire length of the scale.

If a drawing is to be made *half-size*, every six inches measured on that drawing will be equal to one foot measured on the thing which is drawn, and to efficiently make this drawing, a scale should be used whose length was divided into nominal feet, each six inches long, and each nominal foot into 12 nominal inches, and each nominal inch into nominal halves, quarters, eighths, and sixteenths, throughout the entire length of the scale. Although these nominal graduations are only one-half the size of the real measurements which their names indicate, they should be read and thought of as though they were the full size. So with all other scales, one-eighth for instance, in which  $1\frac{1}{2}$ "' on the drawing is equal to 1 foot on the thing being drawn. Each  $1\frac{1}{2}$ "' on this scale should be marked a foot and considered as such and be subdivided into inches, and each inch into quarters. Although each  $\frac{1}{4}$ "' division of the scale actually measures only one-thirty-second of an inch, this fact should not be thought of, but the distance should be considered as a quarter of an inch.

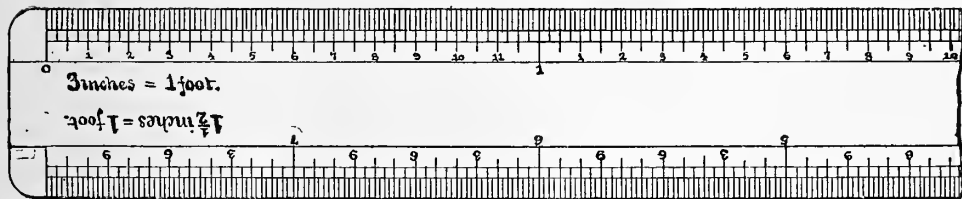

The importance of having the subdivisions of the inches graduated throughout the entire length can be appreciated, when the fact is considered, that a large proportion of the dimensions on a drawing have to be laid off so as to come half on one side and half on the other side of a centre-line or axis of symmetry, when, if only one foot of the scale is subdivided and the measurement exceeds a foot, the scale will have to be shifted. This is awkward and consumes time unnecessarily.

To illustrate the advantage of dividing the length of the scale into feet, and each foot into inches, instead of simply marking the inches consecutively throughout the length, suppose it is required to lay off the width of some object which is symmetrical about a centre-line, and that this width is  $2' 9\frac{1}{2}''$ . If each foot is designated, a foot mark can be placed upon the centre-line and the half distance,  $1' 4\frac{3}{4}''$ , be immediately laid off in both directions with a minimum of trouble and chance of error. Therefore, in selecting scales, never take any in which only the first foot is

subdivided, nor in which the inches are marked continuously without separation into feet.

### LINES.

The Plates in this Course are drawn with the same conventional lines as in the preceding ones; that is, the full lines and short dots represent lines of the object being drawn and are to be inked *black*, the long dots represent centre-lines and important bases and lines of reference and are to be inked *blue*, and the long-and-short dots represent construction lines used in obtaining the lines of the object, the preservation of which is desirable, and are to be inked *red*. All dimensions lines are *red*. All red and blue lines are to be full, not dotted. If, however, a tracing of the drawing is required for the purpose of obtaining Blue Prints, the lines should all be black and be distinguished as in the Plates.

The size of paper to be used is 21" by 16" with margin lines 20" by 15", the same as in the preceding Courses.



## HELIX AND HELICOID.

### PLATE 21.

If a Cylinder is rotated on its axis with a uniform velocity, and a stylus is given a uniform motion in a straight line parallel to this axis, the point of the stylus, if pressed against the cylinder, will trace a *helix* upon its surface. The distance which the point travels during one revolution of the cylinder, is the *pitch* of the helix.

Draw the top and front views of a cylinder 4'' diameter and 3'' long as shown in the Plate. If this is supposed to be rotated on its axis with a uniform velocity, and a point, starting at *a*, to be moved with a uniform velocity along the line *ab* so as to arrive at *b* at the same time that the cylinder has made one turn, the point will have drawn a *helix*, *acb*, of 4'' diameter and 3'' pitch.

As the velocities are uniform, it is evident that when the cylinder has made any given fraction of a revolution, the point will have moved the same fraction of the pitch, and to draw the projections of the helix it is only necessary to divide the circle, representing the circumference of the cylinder in the top view, into any number of equal parts, say 24, and the pitch *ab*, in the front view, into the same number of equal parts, and to project vertical lines from the former to intersect horizontal lines from the latter, when these intersections will be points of the helix.

An examination of the location of these points will show that they are symmetrically distributed to the right and left of the centre-line, and above and below the horizontal line passing through the point  $c$ , which is half the pitch, and that it is therefore only necessary to determine one-fourth of the curve.

In the present case divide the pitch  $ab$ ,  $3''$ , into four equal parts, each  $\frac{3}{4}''$ , and draw horizontal lines through these four points, then the helix will be at  $d$  at the end of the first quadrant, at  $c$  at the end of the second quadrant, at  $e$  at the end of the third quadrant and at  $b$  at the end of the complete turn, and the curve will be precisely the same in each of these four quadrants, only reversed.

Now divide the first quadrant into six equal parts and determine accurately six points of the helix. Select a portion of the edge of an *irregular curve* which will pass through as many of these points, from  $d$  towards  $a$ , as possible and draw a curve through them. Make marks on the irregular curve where it crosses the centre-line and outside of the cylinder and draw the same portion of the helix from  $d$  towards  $c$  by placing the irregular curve so as to have the same mark at  $d$ , and the mark which was at or near  $a$  to be at or the same distance from  $c$ . Then carry the marks over to the opposite side of the irregular curve and go through the same operation, using the opposite side, from  $e$  to  $c$  and from  $e$  to  $b$ . A small portion of the helix at  $a$ ,  $c$ , and  $b$ , can often be best made with the compasses.

To *develop* the helix, draw the line  $bb'$ , equal to the circumference of the cylinder,  $12.5664''$ , divide this line into 24 equal parts, erect perpendiculars at each of these

points and continue the horizontal divisions of the pitch to intersect these perpendiculars, when it will be found that the development of the helix is a straight line from  $a$  to  $b'$ . This must necessarily be so, as  $b b'$  represents a uniform revolution of the cylinder and  $a b$  a uniform translation of the point. The angle  $a b' b$  is the angle which a tangent to the helix makes with the plane of the base of the cylinder. This suggests a method of finding this angle trigonometrically from a table of natural tangents. The length of the circumference of the cylinder is to unity, as the pitch of the helix is to the natural tangent of the angle, hence, tangent of the angle =  $\frac{\text{pitch}}{\text{circumference}}$ . Make this division and find from the table of tangents the angle corresponding to the quotient. This angle will be  $13^{\circ} 25'$ .

This development of the helix also suggests a ready and useful method of determining any irregular curve that may be desired on the surface of a cylinder, as for the production of intermittent motion or varying velocities. The lengths of the divisions upon the development of the circumference represent the velocity of revolution in equal times, and the lengths of the vertical lines at these divisions represent the velocity of translation of the point in the same times. These can be made anything that may be desired and the points projected back to the cylinder.

Now, inside of this 4" cylinder, draw one  $3\frac{1}{8}$ " diameter, having the same axis and the same length, 3", and upon it draw a helix  $f, g, h$ , the development of which will be  $f h'$ , making an angle of  $17^{\circ}$  with the plane of the base. This helix has the same

pitch, 3'', as the former one, but the diameter being less, the helix will be steeper, that is, a tangent to it will make a greater angle with the plane of the base.

An examination of the top-view will show that each fraction of the circumference of the inside cylinder is on the same radial line as the corresponding fraction of the outside cylinder, while the front view will show that the corresponding fractions of the pitch are on the same horizontal lines. If an infinite number of radial lines could be drawn in the top-view, they would be projected in the front-view as horizontal lines and would constitute the elements of a warped surface called a *helicoid*, connecting the two helices. This is the surface of the ordinary *screw thread* and is an important one. The elements, or lines composing it, need not be perpendicular to the axis but can be at any angle. If they are perpendicular, the thread is called a *square thread*, if at an angle, a *V thread*. Therefore, *the warped surface of a screw thread, or a helicoid, is generated by a straight line (called the generatrix) moving uniformly along another straight line (called the directrix), and at the same time moving uniformly around it, and always making the same angle with it.*

The drawing thus far represents two cylinders, one 4'' and the other  $3\frac{1}{8}$ '' diameter, with the same base and axis, and with a helix of 3'' pitch on each, and with the space between these helices representing the surface of a screw-thread of this same pitch. The 4'' cylinder represents the *outside diameter* of the thread, and the  $3\frac{1}{8}$ '' cylinder, the *inside* or *root diameter*. It is now necessary to complete the thread, for as yet only an imaginary surface has been obtained. Before doing this, however,

an understanding of the purposes and nature of a screw-thread should be obtained. Its purpose is essentially to change continuous rotary motion into continuous linear motion; that is to say, if a shaft, having a screw-thread upon its surface, be rotated and the helicoidal surface of the thread be made to bear against any object, such object will be moved along the shaft in the line of its axis. The distance moved for each revolution of the shaft will equal the pitch of the thread. The surface of the object, which bears against that of the thread, should coincide with it to the greatest extent possible, hence it should be a similar thread wound on the *inside* of a cylinder, called a *nut*, of a diameter equal to the outside diameter of the screw. The nut can be given any desired length so as to contain as many turns of the thread as experience or experiment may determine to be necessary. The surface of the screw slides upon the surface of the nut in the manner of a spiral wedge, exerting pressure and causing motion axially. The greater the extent of this surface, the more will the pressure be distributed and the less will be the consequent wear. The greater the pitch of the screw, the greater will be the relative motion of the nut. The smaller the diameter of the thread, relatively to the pitch, or the greater the *pitch-angle*, the smaller will be the amount of sliding of the surfaces required to produce the motion, and consequently the less loss from friction. The more nearly perpendicular the generatrix of the screw surfaces is to the axis, the less the loss from friction, hence a square thread is the most efficient for producing motion, while a V thread is the most efficient for holding pieces firmly together, because the friction tends to prevent the thread from

slipping back after tightening. For screws designed to give motion, the pitch-angle should be large, but not more than  $45^\circ$ , while for those designed to hold pieces together, the pitch-angle should be small.

In the drawing of the 4'' screw, one of the helicoidal surfaces or one side of the thread was completed, and the next step is to draw the other side. In ordinary square thread screws, the width of the thread is made  $\frac{1}{2}$  the pitch, and the depth  $\frac{7}{16}$  the pitch, or  $\frac{2}{3}$  the width. In the present case, the depth has been taken as  $\frac{7}{16}$ '' , and therefore the width would be  $\frac{1}{2}$ '' , which would leave a space between the turns of  $2\frac{1}{2}$ '' . This space can be utilized by making two other similar threads in it, thus gaining three times the amount of wearing surface of a single thread in the same length. This will therefore be a screw of 3'' pitch with triple thread, each thread will be  $\frac{1}{2}$ '' wide and  $\frac{7}{16}$ '' deep, or the same as if the pitch was 1'' instead of 3'' . When there is more than one thread, the combined width of screw and space is called the *individual pitch*. This expression refers solely to the axial measurement of the thread and space, and must never be used in mistake for the real pitch, which is the axial distance traveled during one turn of the thread.

In drawing the helices already determined, an irregular curve was used and marked to facilitate the reproduction three times of one-fourth of the curve. Now lay off distances of  $\frac{1}{2}$ '' on lines parallel with the axis, from any points of the original helices, which will enable the irregular curve to be located the same as it was for them, and complete the curves for all the threads.

An examination of the drawing thus completed, of a square-thread screw, 4" diameter, 3" long and 3" pitch, triple thread, will show how unnecessary it is, after having made and understood a drawing of one screw, to go through the tedious operation of determining the front view of ordinary screw threads, and how little useful information such a view imparts. Now draw a continuation of the screw,  $1\frac{1}{2}$ " long, *in section* on the central plane. This will show clearly the shape of the thread and space, and their widths and depth, and needs only to be supplemented by the statement that the screw is 3" pitch, triple thread.

The true helices should, however, be carefully and accurately drawn full size in this example, in order to obtain a clear comprehension of the subject, because there are many cases in which an exact determination of the curves and surfaces is very important, as, for instance, in the screw propeller.

If the underlying principles are fully understood, but little difficulty need be anticipated with any helicoidal surface. The line in which a section in the plane of the axis cuts this surface is the generating line. This line intersects the axis, revolves uniformly around it, and travels uniformly along it the length of the pitch for each revolution. Every point of the line generates a helix of the same pitch, while the line generates a helicoid. The line may be at any angle with the axis, and the helix generated by any point of it can be readily projected and developed.

### CONVENTIONAL REPRESENTATION OF SCREW-THREADS.

Instead of drawing the true helices of an ordinary screw-thread, it is as clear, as useful, and almost always allowable to represent them by straight lines.

To illustrate this, draw as in Plate 21, six shafts, each 1" diameter and 4" long, to be threaded for 2" of their length with square thread. Let the thread on one pair be  $\frac{1}{4}$ " pitch, on the next pair  $\frac{1}{2}$ " pitch, double thread, and on the last pair  $\frac{3}{4}$ " pitch, triple thread. The width of the thread, being half the pitch of a single-thread screw, will be  $\frac{1}{8}$ ", and the depth will be  $\frac{7}{8}$  of this, or  $\frac{7}{64}$ ". Therefore the diameter at the root of the thread will be  $\frac{23}{32}$ ". Draw the root diameter. Then lay off  $\frac{1}{8}$ " spaces on the outside diameter. Each alternate one of these will be a thread, which will advance half the pitch in half a revolution. Therefore draw parallel straight lines, inclined an amount equal to half the pitch, as shown, to represent the outside helices on the front surface of the cylinder, and, in the spaces between the threads, draw portions of similar straight lines, inclined the same amount in the opposite direction, to represent what can be seen of the helices on the back surface.

By referring to the 4" screw, it will be noticed that the helices at the bottom of the square thread, begin opposite the beginning of the outside helices and disappear at the central plane, therefore draw straight lines from the central plane to these points, as shown.

Even this amount of work is generally considered superfluous in shop-drawings



and one of the three *conventional* methods shown is usually employed. The upper one, in which only a few threads at each extremity of the screw are indicated, and in which the root diameter is expressed by dotted lines, is the clearest. The bottom one is the simplest and is often sufficient, but in all cases of working drawings of square-thread screws, the pitch should always be given, no matter how the threads are drawn. The middle one is shown in section, the section representing *wrought iron* or steel by means of a wider space between each three of the lines. This is a conventional method of distinction from cast iron, in which the section lines are regularly spaced, as shown in the 4" screw. If the material is steel, this word should always be written upon the piece. Steel is often represented by dotting the middle one of the three lines, but the operation is tedious and the result sometimes uncertain. Thus far, the screws have all been right-handed, and a means must now be obtained by which a "*right-hand screw*" can always be identified. Take, in imagination, the blank end of a screw or the head of a bolt in the hand, with the screw pointing away from the person, insert the other end in a nut and revolve the screw so that the *top* surface moves to the *right*, then, if the inclination of the thread is such that the screw will advance into the nut, the screw is right-handed. A "*left-hand screw*" is the opposite of this. The word left-hand should always be written on the drawing, even if the direction is properly shown, as thus: *left-hand square thread, 3" pitch*. A thread is always presumed to be single and right-handed. If otherwise, the information should be written on the drawing to avoid mistakes.

It is customary to make the pitch of square-thread screws twice, or the number of threads per inch one-half that of standard bolts, as given in the Table on page 97. Therefore, a *standard square thread* is double the pitch of a standard bolt of the same diameter, the thickness of the thread is  $\frac{1}{2}$ , and the depth  $\frac{7}{16}$  its own pitch.

The sides of the threads of screws can be given any desired angle and depth, according to their purpose, but there are no universal standards except for bolt and gas-pipe threads (to be considered farther on), and for square threads, as above. Numerous local standards, such as sharp V threads, half V threads, bastard threads, hydraulic threads, etc., are used for special purposes, but it is only necessary to fully consider the standards for bolts and pipes, as universally adopted in the United States.

---

## BOLTS.

Bolts are round bars with a screw-thread on one end and a head on the other, and are used for holding pieces together. They are more largely and universally employed in engineering construction than any other single piece. Realizing the importance of a uniform system for their proportions, Mr. William Sellers, on April

21st, 1864, read before the Franklin Institute of Philadelphia, an "Essay on a System of Screw-Threads and Nuts," which gave the results of his experience, investigations and experiments, and the proportions which he recommended. This system has been adopted throughout the United States, and is known either as the Sellers, the Franklin Institute or the United States Standard proportions for Bolts and Nuts. The Table on page 97 gives these proportions for bolts from  $\frac{1}{4}$ " diameter up to 3" diameter.

The pitch of the screw is indicated by the number of threads or pitches in one inch of length, in order to avoid fractional measurements. A section of the screw in the plane of the axis will give what is called the shape of the thread. This shape is a V whose sides make an angle of  $60^\circ$  with each other. The top of the thread is cut off to make a flat equal to  $\frac{1}{8}$  the pitch and this same amount is filled in the bottom to make there an equal flat of  $\frac{1}{8}$  the pitch. This makes the depth of the thread equal to .65 pitch. Draw the section of a portion of this standard thread 2" pitch, as shown. The Bolt Heads and Nuts are made either hexagonal or square, according to their purpose. Their short diameter is equal to one and one-half times the diameter of the bolt plus one-sixteenth of an inch, and their thickness is equal to the diameter of the bolt minus one-sixteenth of an inch. By short diameter is meant the perpendicular distance between the sides of the hexagon or the square.

Unfortunately, at the time that this system was originated, the lack of manufacturing facilities seemed to render it advisable to make a different standard for finished

bolt-heads and nuts from that for black ones, in order that the former could be produced by cutting  $\frac{1}{32}$ " from each side of the latter, and the standard for the latter was made  $\frac{1}{16}$ " larger than the former to allow for this. The inconvenience of this error was soon discovered, and while Mr. Sellers and many other eminent engineers adopted and have always adhered to the finished sizes as the standard for both finished and black bolt-heads, very many others, including the U. S. Government, adopted the black sizes, with the result that as regards heads and nuts there are now two standards and consequently a wrench made at one place may be  $\frac{1}{16}$ " too large or too small for a nut made at another place.

Now draw a *Standard Bolt*, 1" diameter,  $4\frac{11}{16}$ " long, threaded to  $3\frac{1}{8}$ " from head, with hexagonal nut and with washer. Make, first, a front view, showing the diameter and length of the bolt, the short diameter and thickness of head and nut (which will so far be simply rectangles), the diameter and thickness of the washer (in section), and the standard thread dotted within the nut and with the helices represented by straight lines on the part outside of the nut, but do not dot these conventional helices within the nut. A good method of procedure, in drawing this standard V thread, is to mark off spaces equal to the pitch on one side of the cylinder and one mark on the opposite side equal to half the pitch or midway between any two of the former. Then draw parallel lines, with this inclination, across the cylinder to represent one of the outside helices. Lay off the root diameter, and draw lines for the root cylinder. Draw  $60^\circ$  lines from where the helices already drawn touch the outside cylinder to

the root cylinder, but only on one side of the thread. Then draw  $60^\circ$  lines for the other side of the thread, setting the triangle so that the lines will leave equal spaces at top and bottom of thread. This will give all the points for the completion of the rest of the conventional helices, those for the bottom of the threads having greater inclination than those for the top.

Next make an end view, showing the circles of the diameters of the washer and bolt. The root of the thread is conventionally shown by a circle of the root diameter, one-half of which is a full line and one-half dotted.

It now remains to complete the head and nut. These will be hexagonal prisms  $\frac{15}{16}$ " long with short diameter  $1\frac{9}{16}$ ". Draw the hexagon in the end view and from this the projections of the sides in the other views. The corners of the outside ends of the head and nut are not left sharp but are beveled off, or chamfered as it is called, and the resulting shape is that of the intersection of a hexagonal prism with a cone having the same axis.

To determine this cone, draw, in the front view, a line at  $45^\circ$  with the axis, that will cut off about  $\frac{1}{16}$ " from the corner of the nut. Where this line cuts the axis will be the apex of the cone. Draw its other side, project the apex to the top view and draw the cone there. The lines of intersection of the nut with the cone will be hyperbolas, which can be approximated by arcs of circles. The tops of these arcs will be determined by the intersection of the sides of the nut with the cone in the front view, and their extremities by the intersection of the corners of the nut with the cone in

the top view. Draw lines across both views from these intersections to determine the points of the arcs and find centres by trial from which to describe them.

The constant recurrence of bolts in Shop-drawings makes it desirable that they should be represented in as simple a manner as possible. This is accomplished by omitting the V of the thread entirely and merely drawing inclined, fine, parallel lines of about the proper inclination and at about the distance apart of the helices of one of the external edges of the thread, as shown. Only one view, showing the length of the bolt, is given, and that is on a plane perpendicular to two sides of the head. The chamfer of the head and nut is indicated by arcs, tangent to the extreme ends of the head and nut, described with a radius equal to about  $\frac{4}{5}$  their thickness. An end view, showing the hexagon, may be made, but is not essential. The washer should always be shown in section, as by this means the fact that it is a separate piece is emphasized.

Draw the same bolt in this manner, alongside of the other one, to demonstrate that this conventional method gives sufficient directions for the construction of a standard article which is being continually reproduced.

## STEAM, GAS, AND WATER PIPE.

Pipes are made by bending strips of wrought-iron into long cylindrical tubes and welding the seam by means of a special furnace and machinery. Screw-threads are cut on each end to fit corresponding threads on the inside of the fittings, but the cut is tapering, that is to say, the helices are described on a cone instead of a cylinder. This enables the screw to be easily entered in the nut, and at the same time permits a very tight joint to be made without great accuracy in their relative diameters. The thread is a sharp V, its outside diameter being smaller than that of the pipe at the extreme end. This diameter gradually increases and the thread disappears. The taper is  $\frac{3}{4}$ " to the foot, or, in other words, the cone, if produced, would increase  $\frac{3}{4}$ " in diameter for every foot of its length.

There is a great discrepancy between the nominal and actual inside diameters of wrought-iron pipes, due to a want of proper means of manufacture and of knowledge of their required strength, at the time when their use was begun. The standard for outside diameter and pitch of thread, which was first adopted, has been adhered to, in order to maintain interchangeability, while improvements in manufacture and a better understanding of the conditions have enabled thinner iron to be used, and the inside diameter has been correspondingly increased.

The Table on page 98 gives the standard proportions for pipes, as used in the United States.

## SHOP DRAWINGS.

Among all the constructive trades or mechanic arts, there is none in which the variety of operations, the multiplicity of detail, the accuracy of measurements, the mathematical calculations, the scientific requirements, and the harmony and unity essential in the work of a large number and variety of skilled mechanics and engineers, are so great as in machine construction, and the great secret of the efficiency of the modern machine shop in producing original and intricate machines at reasonable expense and with successful results, lies in the system of *working drawings* which is employed. The study, therefore, of such working drawings cannot fail to be of benefit to any one desiring to express and record mechanical ideas relating to any constructive art.

As the Steam Engine is an interesting machine and one whose parts are comparatively few and familiar, it has been selected for the purpose of making a complete set of such drawings, sufficient to enable every detail to be constructed and the whole to be assembled and erected. The type will be a small vertical engine with steam cylinder 6" diameter, having a piston stroke of 8", single eccentric, plain D slide valve, and all the parts as simple as possible. The subject will be approached, not with the view of designing the engine, nor of investigating the principles of steam engineering involved, but merely of making the drawings necessary for its construc-



tion. Therefore, it will be assumed, in the first place, that the proportions have been calculated, the form determined and the complete *construction-drawing* finished by a competent man, and placed in the hands of an apprentice for the purpose of having separate drawings made of every piece, which would enable a number of workmen to perform independently and at the same time harmoniously, the various operations necessary. When all the detail-drawings are finished, a construction-drawing will be made, such as would enable these details to be properly assembled and the complete engine to be erected.

---

## VERTICAL ENGINE.

When the designer has completed his construction-drawing, he should make lists of all the different pieces comprising the engine, giving to each piece a number and a definite name, by which it can always be identified. This will prevent the confusion which is sure to arise when any latitude is allowed in the naming of the details. One name, even if unsuitable, is preferable to two appropriate ones for the same piece.

The lists for the 6'' by 8'' Vertical Engine shown by Plate 34 are as follows :

## LISTS OF DETAILS.

## LIST OF IRON CASTINGS.

1-No. 1.—Frame, . . . . .	Plate 33	1-No. 13.—Back Cap, Crank Shaft, . . .	Plate 31
1- “ 2.—Cylinder, . . . . .	“ 32	1- “ 16.—Eccentric, . . . . .	“ 29
1- “ 3.—Steam Chest Cover, . . . . .	“ 31	1- “ 17.—Top Half of Eccentric Strap, . . .	“ 29
1- “ 4.—Cylinder Head, . . . . .	“ 31	1- “ 18.—Bottom Half Eccentric Strap, . . .	“ 29
1- “ 10.—Slide Valve, . . . . .	“ 28	1- “ 19.—Fly Wheel, . . . . .	“ 27
1- “ 11.—Piston, . . . . .	“ 26	1- “ 20.—Crosshead, . . . . .	“ 28
1- “ 12.—Front Cap, Crank Shaft, . . .	“ 31		

## LIST OF BRASS CASTINGS.

1-No. 5.—Gland in Cylinder, . . . . .	Plate 26	1-No. 22.—Lower Brass in Conn. Rod, . .	Plate 30
1- “ 6.—Bushing in Cylinder, . . . . .	“ 26	1- “ 23.—Bushing in Connecting Rod, . .	“ 30
1- “ 7.—Stuffing Box for Valve Stem, . . .	“ 30	3- “ 24.—Oil Cup with straight outlet, . .	“ 30
1- “ 8.—Nut on 7, . . . . .	“ 30	4- “ 25.—Oil Cup with side outlet, . . .	“ 30
1- “ 9.—Gland in 7, . . . . .	“ 30	7- “ 26.—Oil Cup Cover, . . . . .	“ 30
2- “ 14.—Front Brass for Crank Shaft, . .	“ 26	3- “ 27.—Oil Tubes, . . . . .	“ 30
2- “ 15.—Back Brass for Crank Shaft, . .	“ 26	4- “ 28.— $\frac{7}{16}$ Standard Brass Nut on	
1- “ 21.—Upper Brass in Conn. Rod, . .	“ 30	Valve Stem, . . . . .	“ 23

## LIST OF FORGINGS.

1—No. 500.—Crank Shaft, . . . . .	Plate 25	2—No. 510.—Stud Bolt in Cylinder, <i>Black</i> , Plate 22	
1— “ 501.—Connecting-Rod, . . . . .	“ 24	2— “ 511.—Round Head Bolt in Con.	
1— “ 502.—Eccentric Rod, . . . . .	“ 24	Rod, . . . . .	“ 22
1— “ 503.—Piston Rod, . . . . .	“ 23	10— “ 512.—Stud Bolt in Steam Chest,	
2— “ 504.—Piston Ring, . . . . .	“ 23	<i>Black</i> , . . . . .	“ 22
1— “ 505.—Valve Stem, . . . . .	“ 23	2— “ 513.—Stud Bolt for Cyl. Gland,	
1— “ 506.—Crosshead Pin, . . . . .	“ 23	<i>Black</i> , . . . . .	“ 22
1— “ 507.—Valve Stem Pin, . . . . .	“ 23	2— “ 514.—Round Head Bolt in Eccen-	
4— “ 508.—Stud Bolt for Caps to Frame,		tric Strap, . . . . .	“ 22
<i>Black</i> , . . . . .	“ 22	1— “ 515.—Steel Key in Eccentric, . .	“ 22
10— “ 509.—Bolt in Cylinder, . . . . .	“ 22	1— “ 516.—Steel Key in Fly Wheel, .	“ 22

In order to readily recognize forgings, their numbers begin at 500, and any number below 500 must therefore be a casting. These numbers should be put on the corresponding pieces in the Construction Drawing in *red* ink to aid in identifying the parts when the machine is assembled, and to be obviously distinct from the dimensions.

Having now the Construction Drawing and the Lists, it is required to make Detail Drawings, showing each piece separately. Good judgment and experience are required in selecting and distributing the pieces on such drawings, so as to keep together as much as possible those requiring similar operations to be performed upon

them, and thus avoiding demands for the same drawing from different persons at the same time.

The detail sheets should be of uniform size and not too large for convenient handling. The printed plates in this Course are the same size as in the preceding, namely, 5 inches by  $3\frac{3}{4}$  inches within the margin lines and should be drawn on sheets either  $10\frac{1}{2}$  inches by 8 inches, in which case the scale would be double, or 21 inches by 16 inches, in which case the scale would be four times that of the printed plates.

The lines should be inked in the same manner as heretofore, that is, all lines representing the pieces themselves should be *black*, the circles and curves being inked first and shaded at the same time, then all the fine and dotted lines and then the heavy shade lines. After all the black lines on the sheet are finished, the centre lines, represented by long dots in the plates, should be inked *blue* but not dotted, and then the dimensions lines made in *red*. All lettering and figuring should be *black*,

Put in the dimension lines and figures directly in ink without previous pencilling. This is readily accomplished, saves time, and avoids unnecessary erasures. Put the number of the Plate always in the same place and the title always in the lower right-hand corner of the sheet as it lies lengthwise. This enables any desired one to be readily found among a package of them, and is a great advantage over the bad method of placing the title wherever there happens to be room for it or where it will look the best. Never finish a drawing or even a sketch without putting your name and the date upon it, as these are never

useless and frequently are of great value in tracing the history of a machine and in establishing the priority of an invention.

The theory of orthographic projections, which has already been fully treated in the Junior and Intermediate Courses, must be strictly adhered to in the practical application which is now to be made of it, and the different views that are essential to a clear comprehension of an object must be arranged in accordance with this theory, and never misplaced for convenience in drawing when there is any risk of a consequent misunderstanding. Such conventionalities and abbreviations as are clear and unmistakable and the omission of such views as do not give additional necessary information, are not only allowable but also desirable. The purpose to be kept constantly in view is to give all information necessary to enable the thing to be constructed, with the least risk of causing misunderstandings and errors, and to give this information in the clearest and simplest manner possible.

The detail plates are arranged progressively, beginning with the smallest and simplest forgings and ending with the Engine Frame, so that every piece can be understood before the construction drawing of the Engine is made.

## BOLTS AND KEYS FOR ENGINE.

### PLATE 22.

Make a detail drawing of all the BOLTS and KEYS of 6" by 8" Engine shown on Plate 34.

The Caps over crank-shaft bearings are held by two  $\frac{3}{4}$ " *stud-bolts* for each cap. A stud-bolt has no head. It is threaded on both ends, one of which is screwed into the stationary piece a distance equal to one and one-half times its diameter and the other has a standard nut upon it for the purpose of holding the movable piece. Stud-bolts are used in places where through-bolts cannot be, and where the piece that is held by them has to be occasionally removed. They are preferable, for this purpose, to *Tap-Bolts*, as an ordinary bolt is called, which passes through the movable piece and is screwed into the stationary piece. A *through-bolt*, called simply a bolt, is one which passes through both pieces. When a bolt is required to fit accurately and thus prevent any possible lateral movement, the through-bolt is the best. When this cannot conveniently be used, the stud-bolt should be, because, when once fitted to place, it need never be removed and thus all wear and change of alignment is avoided. If, however, two pieces are bolted together permanently, the tap-bolt will serve the purpose.

Find the length of the  $\frac{3}{4}$ " Stud-Bolts required to hold the caps and draw one as

shown, with a nut on one end, the threads indicated, and the dimensions marked. No dimensions are required for the nut, as this is a standard article, presumed to be made in quantity and taken out of stock. The thread upon the end which screws into the casting is  $1\frac{1}{8}''$  long, or  $1\frac{1}{2}$  diameters, while that upon the other end is somewhat longer than the thickness of the nut, to allow draught. The total length of the bolt should always be given to save calculations in the shop, but the allowance for rounding and finishing the end should be left to be determined by the method of manufacture.

Draw, in like manner, the two  $\frac{5}{8}''$  stud-bolts in the cylinder. The length of these is made up of the distance to which they are screwed into the cylinder,  $1\frac{5}{8}''$ , the thickness of the flanges through which they pass,  $\frac{3}{4}''$ , and the thickness of the nut,  $\frac{9}{16}''$ —a total of  $2\frac{1}{4}''$ . As they do not fit the holes, there is no necessity of their being finished, and they should therefore be marked *black*. This is the only distinction required between a forging which is to be used as it comes from the smith and one which is to be tooled and finished all over. The drawing in both cases is the same. When no note is made the piece is to be finished all over, when marked *black* it is not to be finished at all. If certain parts of it are to be finished and the rest left black, put the letter *f* across the lines representing the finished surfaces or draw long-and-short dots parallel and close to these lines.

Now group together all the rest of the bolts and also the keys required for the Engine and draw them as shown on Plate 22. The bolts numbered 511 and 514

have round heads. The diameter of a round head is one and one-half times the diameter of the bolt. The thickness of the head is one-half its diameter, neglecting thirty-seconds.

The large number and variety of bolts required in building machines frequently make the drawing of them a very tedious operation and form an inducement to abbreviate as much as possible. Their standard character and the familiarity of the workman with their manufacture, render this abbreviation possible and desirable. In Plate 22, the end-views could be dispensed with altogether without detriment; or, instead of a drawing, a list could be made, giving the kind, diameter, and length of bolt, the kind, diameter, and thickness of head, the length of thread and the place where the bolt is to be used, as thus:

4—No. 508. *Stud Bolt*,  $\frac{3}{4}$ " dia.,  $2\frac{11}{16}$ " long, with ends cut  $1\frac{1}{8}$ " and  $\frac{7}{8}$ ". For Caps to Frame.

10—No. 509. *Black Bolt*,  $\frac{5}{8}$ " dia.,  $2\frac{1}{16}$ " long, with end cut to  $1\frac{5}{16}$ " from head. *Black Hex. Head*, 1" dia.,  $\frac{9}{16}$ " thick. In Cylinder.

2—No. 511. *Round Head Bolt*,  $\frac{5}{8}$ " dia.,  $3\frac{9}{16}$ " long, with end cut to  $2\frac{1}{16}$ " from head. *Round Head*  $\frac{1}{16}$ " dia.,  $\frac{1}{2}$ " thick. In Connecting Rod.

1—No. 516. *Steel Key*,  $\frac{1}{2}$ " square, 5" long, one end rounded. In Fly Wheel.

The pitch or number of threads of bolts need not be mentioned unless it differs from the standard.



## PISTON ROD, VALVE ROD, PINS, AND RINGS.

### PLATE 23.

Proceed now to make working-drawings of the forgings, beginning with the least complicated and arranging them judiciously, as shown in the Plate. Notice that there are no dimensions on the nuts, because they are standard and no information is required. They might be omitted entirely. The taper of the *Piston Rod* is indicated by giving the diameter of the large end only of the taper part and expressing the amount of reduction to be given the diameter per foot of length. The *Split Pin*, which is used to prevent the possibility of the nut backing off and releasing the Piston, need not be figured except for diameter, because it is a standard article of commerce. The small hole shown in the Valve Stem Pin is for a split-pin. The holes in the *Crosshead Pin* are for oil, the longitudinal one being tapped, 16 threads per inch, to receive an Oil Cup, No. 25. The *Piston Rings* are of the Ramsbottom type, made of steel, bored  $\frac{5}{32}$ " too large, and have the ends finished at an angle with the plane of the axis and sufficiently apart to permit of springing together and turning the outside diameter to fit the 6" bore of the Cylinder. They then possess enough elasticity to preserve a steam-tight fit without causing undue wear. The nuts on the *Valve Stem* are made of Brass to prevent them from rusting fast. They are standard and require no dimensions.

## CONNECTING ROD AND ECCENTRIC ROD.

## PLATE 24.

The *Connecting Rod* is of a very simple type. The crosshead end is spherical, bored to receive a brass bushing and faced off to fit the crosshead. The crank end has a flange with holes for the bolts to hold the brass boxes. It has a longitudinal oil hole drilled to meet a radial one which is tapped for an oil cup, No. 25. The axis of the radial oil hole is also the axis of a spherical swell made in the rod to add metal and strength. As there is not sufficient room on the paper for the entire length of the rod, the ends are drawn complete and the middle part is shown as though broken. This is a very useful device and possesses no disadvantages. Care must, however, be taken in drawing broken taper pieces, such as this one, to preserve the actual taper. No difficulty need be apprehended if it is remembered that a part has been taken out of the centre and the ends brought closer together.

The *Eccentric Rod* has its end in the form of a similar flattened sphere and is also shown broken at the centre.

These breaks are represented as an irregular fracture and are section-lined to represent wrought-iron; that is, with three lines at  $45^\circ$ , then a wide space and then three similar lines, and so on. A wide space between each set of three lines is the

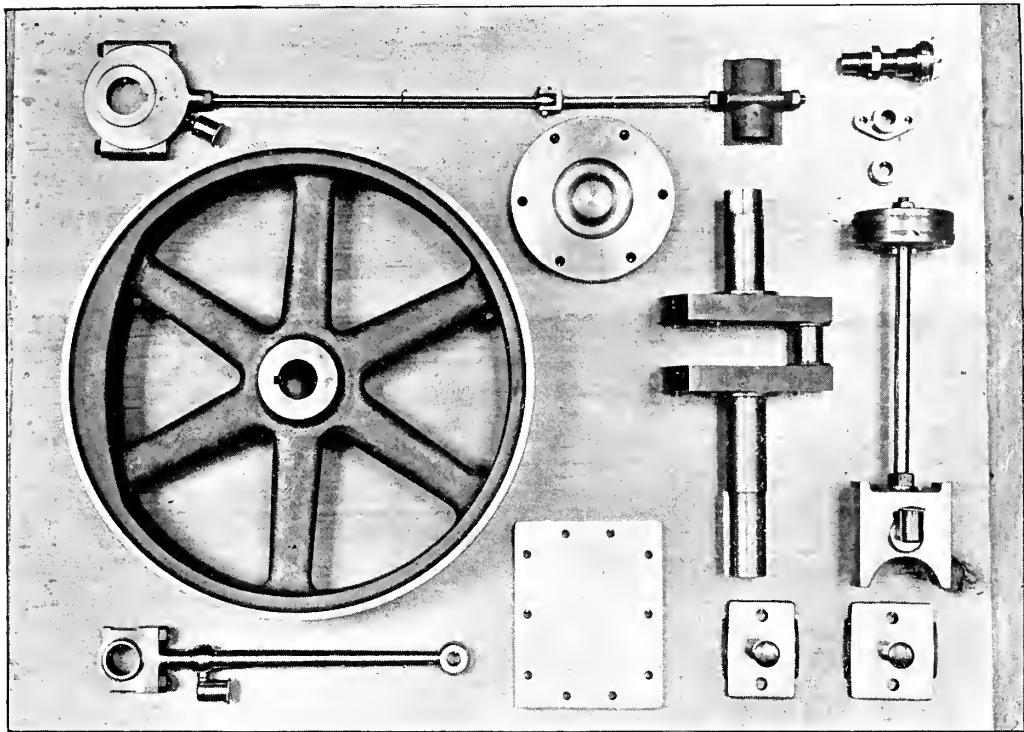



conventional method of representing wrought-iron and steel, but in all cases where steel is intended, the word *steel* should be added to the title of the piece.

---

## CRANK SHAFT.

### PLATE 25.

The *Crank Shaft* is of the type called double-crank, in which there are two arms, connected together by the crank-pin, and dividing the shaft into two portions, which are fitted to the bearings in the main frame or housing of the engine on both sides of the crank. The shafts, the ends of the arms, the bosses and the pin are turned, fillets being made at the junction of the pin with its bosses and at the junction of all the bosses with the arms. The arms are then planed and slotted to the required dimensions. The curves produced by the intersection of the flat edges and cylindrical ends of the arms with the fillets of the bosses are shown in the front view. These curves should not be guessed at but correctly obtained for the benefit of the practice to be derived from the process. To do this, pass through the bosses, in the front view, planes perpendicular to the axis, and draw the circles in the side-view of the traces of these planes on the circumferences of the bosses. Project the points, where these circles

cut the edge of the arm in the side view, to the corresponding planes already drawn in the front view, for the points of the curves. The fillets of the crank-pin are for strength, and those of the bosses for appearance and facility of cleaning. The object of extending the arms to the same distance below as above the axis and of making them tapering, is to obtain as much weight opposite the crank-pin as is possible, consistently with convenience of manufacture, for the purpose of counterbalancing the opposite parts of the crank together with the connecting rod and the reciprocating parts of the engine. Any additional counterbalance that may be desired can be placed in the Fly-wheel and will be shown farther on.

One extremity of the shaft is fitted to the Fly-wheel and the other to the Eccentric, *key-seats* of proper width and depth for the reception of the keys for holding these pieces being shown. These keys are not in the same plane, but their centre lines make the proper angle with each other to produce the required *angle of advance* of the Eccentric. This will be explained when the valve motion is investigated.

All the *forgings* having now been drawn, the *castings* will next be treated in the same manner; that is, each piece will be drawn separately and the several pieces grouped together on sheets.

## PISTON, SHAFT-BRASSES, GLAND AND BUSHING.

### PLATE 26.

The *Piston* is a disc of cast iron, 6" diameter and 2" thick, with two grooves in its circumference to receive the steel rings. These grooves are deeper than the thickness of the rings, to allow the latter to be free to move radially and keep in close contact with the bore of the cylinder. The sides of the rings should fit closely, without binding, to the sides of the grooves. The taper hole in centre of piston has its size marked only at the large end, the taper being given in the same way as has already been shown on the piston-rod.

The *Brass Bushing* is in the lower end of the cylinder and forms a rubbing surface for the piston-rod. The *Brass Gland* is used to compress the packing in the stuffing box to prevent leakage of steam around the piston-rod. These pieces are made of brass to avoid the rusting and sticking which would result if cast iron was used. They are shown in section and the kind of metal is indicated by the spaces between the 45° section lines, a wider space between each set of two lines indicating brass. The word *brass* should, however, always be used in addition to the characteristic section.

The *Brass Boxes* for crank shaft are made in halves in order to permit them to be brought together to take up any lost motion arising from wear. The top and

bottom boxes of each pair are alike, excepting that the top one has an oil hole ; therefore but one of each need be drawn if the fact of the holes is properly noted as shown on the Plate.

---

## FLY-WHEEL.

### PLATE 27.

The *Fly-Wheel* is a pulley with six arms and a hub bored to fit the crank shaft. The outside (called the face of the pulley), instead of being cylindrical, is in the form of two similar cones joined at their bases in the central plane of the wheel. The amount of taper of these cones is given as shown on the Plate, namely,  $\frac{3}{4}$ " reduction in diameter for each foot of length of the cone. This is called *high-face*, and is for the purpose of preventing the belt from slipping off sideways, and to cause it to track properly on the wheel. The inside face of the rim and the outside of the hub are similarly tapered to facilitate the withdrawal from the mould, of the pattern from which they are cast. The thick part of the rim does not extend the full width, in order that the part of it which will come opposite the crank-pin may be still further thickened to any desired amount for the purpose of a counterbalance, while the thin



part can be finished and made to coincide exactly with the plane of revolution. The key-seats in the crank-shaft and the fly-wheel must be so located in reference to the counterbalance that the centre of gravity of the latter will be exactly opposite the centre of the crank-pin.

---

## SLIDE VALVE AND CROSSHEAD.

### PLATE 28.

The *Slide Valve* is of box-shape with circular top and flanges at the edges. It has a boss extending its whole length with a hole cored through it for the valve-rod. The hole is elongated to allow for wear and refitting of the valve without disturbing the alignment of the rod. The functions and operation of this valve will be explained after the working drawings are completed.

The *Crosshead* is tapped to fit the piston-rod, the latter being prevented from backing out by a jam-nut. It is turned to fit the guides in the main frame, and is bored to receive the pin for the connecting-rod.

The sectional views represent cast-iron by means of equidistant lines at  $45^\circ$ .

## ECENTRIC AND STRAP.

### PLATE 29.

The *Eccentric* is a disc of cast-iron bored to fit the front end of the crank-shaft. The outside diameter is a cylinder whose axis is parallel with, but at a distance of  $\frac{5}{8}$ " from the axis of the bore. This distance is the eccentricity and twice this, or  $1\frac{1}{4}$ ", is the motion produced by one revolution, called the *throw* of the eccentric. An eccentric is really a crank-pin which is larger than the shaft. The outside cylinder has a groove at each edge to fit corresponding projections on the inside of the strap, in order to keep the latter in place. The key-seat must be exactly central with a line joining the two centres so that the angular advance can be correctly fixed by the proper location of the corresponding key-seat in the crank-shaft.

The *Eccentric Strap* is made in halves, held together by two close-fitting, round-head bolts and bored to fit the circumference of the eccentric. It is tapped to receive the eccentric rod and also an oil-cup, located at an angle with the vertical centre-line.

**BRASS DETAILS.****PLATE 30.**

The *Connecting-Rod Brasses* are made in halves, bolted together, bored and the corners rounded to fit the crank-pin. The bolts pass through the two boxes and the flange on the end of the connecting-rod. The oil hole in the upper brass coincides with the one in the rod. Another type of connecting-rod and eccentric-rod is given on Plate 35.

The *Stuffing-Box for Valve Stem* is bored to fit the stem, the bore being enlarged at one end to receive the packing and the gland for compressing it. A thread is cut on the outside of this end to receive a nut for forcing in the gland. The other end is turned and threaded to fit the hole in the steam chest into which it is screwed by means of a wrench fitting the hexagonal collar. It is made of brass, as are all the details on this Plate.

The *Gland* for stuffing-box has a flange to facilitate its removal.

The *Nut* on stuffing-box is threaded inside to fit the latter, and has notches on its outside circumference to enable a spanner-wrench to be used for screwing it up.

The *Bushing* in connecting-rod is forced tightly into the latter while its bore is made to work freely on the crosshead-pin. It prevents rubbing contact between two similar metals, and can be easily replaced when worn.

The *Oil Cups* with straight outlet are threaded to fit the holes they are intended for, and have hexagonal collars for a wrench. They are arranged for separate tubes to be driven in.

The *Oil Cups* with side outlet have round collars, as a wrench is not needed for screwing them in place. The tubes are of one piece with the cups.

The *Oil Cup Covers* are threaded to fit the inside of the cups. Their tops are portions of spheres.

---

## COVERS AND CAPS.

### PLATE 31.

The *Steam Chest Cover* is a flat plate with holes for the stud-bolts. These bolts are black, as already shown, and the holes are  $\frac{1}{16}$ " larger than the bolts, nicety of fit not being required. A piece of sheet-rubber, of the shape of the steam-chest flange, is placed between the cover and flange to make a steam-tight joint. The cover is made thicker and planed at this place, and is planed and polished on the outside face and edges for appearance.

The *Cylinder Head* is fitted to the counter-bore and flange of the Cylinder, and its flange is polished on the outside face and edge. Its bolt holes are also  $\frac{1}{16}$ " larger

than the bolts. The socket at the centre is to provide clearance for the nut on the end of the piston-rod.

The *Caps for Crank Shaft* are planed on two sides and two edges. On the other edges are segments of bosses, the centres of which coincide with the centre of the crank shaft. The bolt holes are the same size as the bolts, the latter being finished and acting as *Dowel-pins* to prevent lateral motion. Oil holes are drilled through the centre of the caps to match the holes in the brasses, and are tapped to receive oil-cups.

---

## STEAM CYLINDER.

### PLATE 32.

The *Cylinder* is the most intricate casting in the engine, and should be carefully drawn and thoroughly understood. The bore is 6'' diameter for a length equal to the stroke, 8'', plus the thickness, 2'', of the piston, minus an amount which will permit the piston-rings to slide a little over at each end of the stroke (in this case  $\frac{7}{8}$ '' ) to prevent a ridge being caused by wear. Beyond this length the bore is increased to  $6\frac{1}{8}$ '', for a distance at each end sufficient to allow  $\frac{3}{16}$ '' clearance between the piston and heads. At the bottom end this diameter is made by the core, while at the top

end it is bored to facilitate the entrance of the piston, and to fit the cylinder-head. The bottom end of the cylinder has a circular boss fitting a hole in the top flange of the main frame. This boss is continued in oval shape to make sufficient depth for the stuffing-box, and to receive the stud-bolts, No. 513, for the gland, No. 5. The stuffing-box is contracted next the bore of the cylinder to form a shoulder against which the flange of the bushing, No. 6, is forced. The steam chest is a rectangular box with flanges to match the cover, No. 3, in which flanges are tapped holes for the stud-bolts, No. 512. The chest is wide enough to receive the slide-valve, No. 28, and has finished strips matching the side edges of the latter, and has four bars forming the valve seat, to which the valve is accurately bedded to make a steam-tight joint. The central space between the two inside bars is the *exhaust port*, through which the steam passes to the atmosphere, while the spaces between the inside and outside bars are the *steam ports*, through which it passes to the ends of the cylinder. A boss is placed centrally on the side of the chest, having a hole communicating with the exhaust space and tapped for a 2" exhaust pipe, while a short boss on the top of the chest is tapped for a  $1\frac{1}{2}$ " pipe for the live steam. At the bottom of the chest is an internal boss, bored and tapped to receive the valve-stem stuffing-box, No. 7. The centre of this must be at such a distance from the centre of the bore of the cylinder as to bring it in line with the centre of the eccentric, when in position on the crank-shaft. Through-bolts hold the cylinder to the frame and the head to the cylinder, except where the steam-chest prevents their use and compels stud-bolts to be substi-



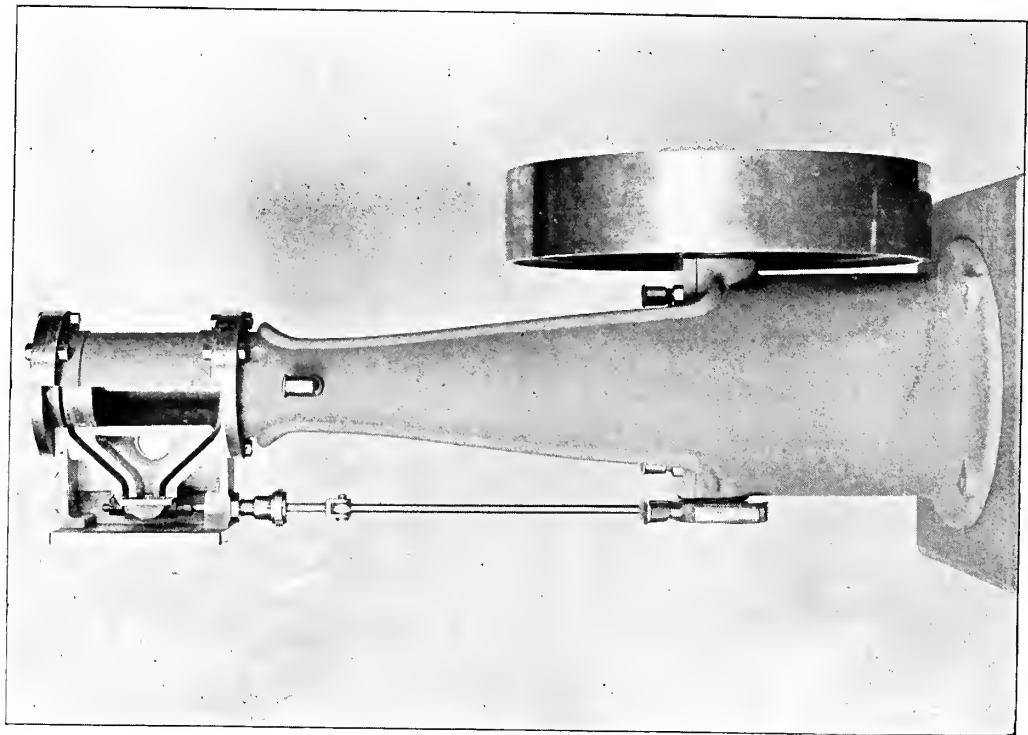



tuted. Holes for draining off the water of condensation are drilled and tapped for  $\frac{1}{4}$ " gas pipe at the bottom of the cylinder, the steam-chest and the exhaust space, and bosses are provided for this purpose, as shown in the Plate. The tapped holes are shown by drawing the V's to indicate the threads, the number of threads not being given, because they are all standard. The "section on line AB," which is shown in the Plate, might be dispensed with, as the only additional information which it conveys is that given by the vertical section through the inclined portion of the steam port, showing that the latter is straight and not curved, and this might be left to the discretion of the pattern maker.

---

## ENGINE FRAME.

### PLATE 33.

The *Frame* has a circular flange at the base and at the top. Its shell is bottle-shaped with a long opening in front and behind, to give access to the working parts inside. This opening has an external flange all around it, to add stiffness and improve the appearance. The seats for the crank-shaft bearings are planed to fit them and are tapped for the stud-bolts to hold the caps. The round bosses on the ends of these

seats are concentric with the axis of the shaft and match those on the caps. The seats are connected by ribs with an internal circular flange below them. The top flange is bored and faced to match the cylinder and bolt holes are drilled in it for the cylinder bolts. The guides for the crosshead are bored at the same time. Oil holes, for which bosses are provided, are drilled and tapped for Oil Cups No. 25, at the upper end of the guides. The shape of the curve of the shell is determined by the diameters at the several horizontal planes taken at the given distances apart. The widths of the openings are determined in the same manner. The flange around the openings projects  $\frac{5}{8}$ " from the exterior all around. The projections of these openings in the side elevation furnish a good opportunity for the student to utilize what he has already learned about projection.

---

## CONSTRUCTION DRAWING OF ENGINE.

### PLATE 34.

This is a drawing of the complete Engine. It is commonly called the *Construction Drawing* and is the original one made in designing the engine. The student should not simply copy it, but should construct the different parts in a logical, systematic manner, as nearly as possible in the natural sequence that would be followed



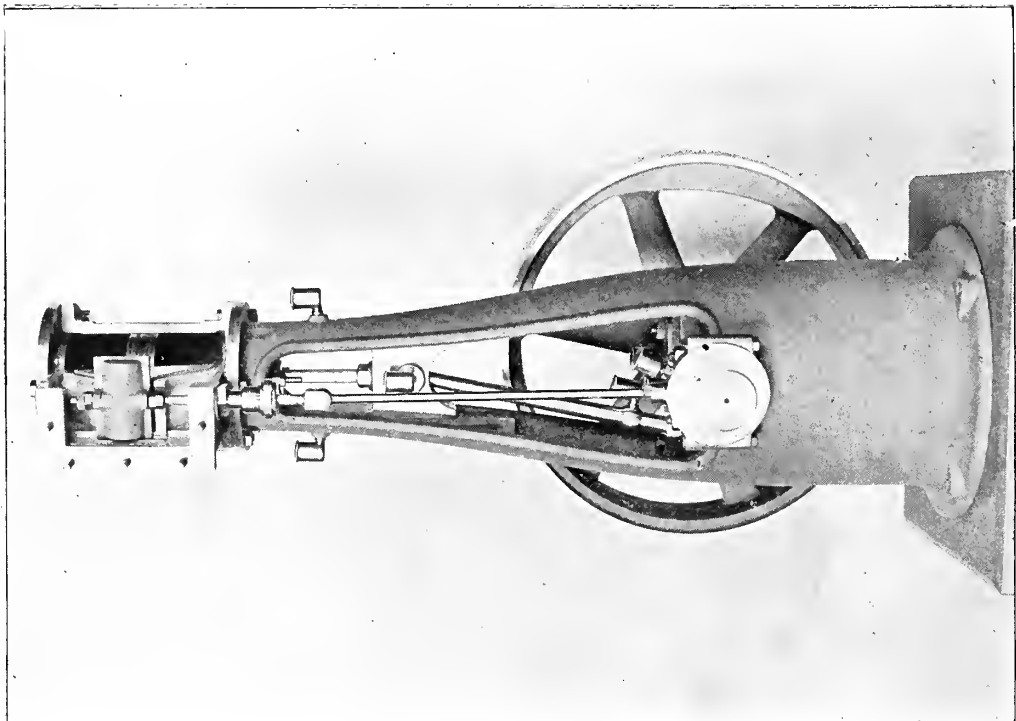

by the designer. The Plate is to a scale of  $\frac{3}{4}$ " to a foot, or one-sixteenth, and consequently many of the small parts and dimensions are obscure, so that in some cases reference will have to be made to the detail drawings.

It is preferable to use a scale of 6 inches to the foot (half size), if the student is provided with facilities for doing so. This would require a sheet of paper 42" by 32". A scale of 4" to the foot would require paper 28" by 21", while a scale of 3" to the foot would take 21" by 16", the standard size used in this and the preceding courses. The latter scale would not be objectionable if the others are impracticable.

Detailed instructions in the method of procedure would be very prolix and confusing, but a general outline may be given with advantage. In the sectional side-view, locate the bore of the cylinder with the piston at the top of its stroke, put in the flanges of cylinder and frame and the stuffing-box and piston-rod with its attachment to the crosshead. Locate the crosshead-pin and from its centre lay off the length of the connecting-rod to determine the centre of the crank-pin, from which lay off the throw of the crank for the centre of the crank-shaft. Draw in the crank and shaft complete and project them to the front view with the bearings and seats. Draw in the front-view of the crosshead and the length of the guides, proportioning them so as to clear the oscillations of the connecting-rod. Lay off, in the side-view, the thickness of the eccentric, the centre of which will determine the centre of the valve-stem, from which the plane of the valve-seat can be obtained. Lay off the steam and exhaust ports and then complete the three views of the cylinder and steam-chest, with covers,

stuffing-boxes, glands, and bolts. Draw in the slide valve so that its upper edge is  $\frac{1}{32}$ " below the edge of the steam port. This is called the *lead* of the valve and is the amount of opening for admission of steam at the moment the piston is commencing its stroke.

As will be explained later, when the valve is in this position the centre of the eccentric is on a radial line passing through the centre of the crank-shaft and making an angle with the horizontal plane of the axis of the shaft, which is called the *angle of advance* of the eccentric. Locate this eccentric-centre in the front-view. A line drawn from this to the centre of the valve-stem pin will be the centre-line on which the eccentric and rod are to be drawn. Project these to the side-view, and then draw the connecting-rod, fly-wheel, oil-cups, and all details complete.

Portions of the steam and exhaust pipes and the arrangement of the drip pipes should be drawn, although not shown on the plates.

After the completion of all the drawings, the student can exercise his inventive faculties by making modifications of it. For instance, the Frame can be altered in various ways to suit special requirements or different tastes, a disc-crank and outside bearing can be substituted, taper shoes can be added to the crosshead for taking up wear, the valve can be moved closer to the bore of the cylinder to reduce the clearance spaces and consequent waste of steam, by introducing a rocker-arm between the eccentric-rod and valve stem with the rock-shaft in a bearing bolted to the side of the frame, and many changes can be made which would be valuable practice for an

advanced student. An excellent exercise would be to change this vertical engine to a horizontal one, retaining the proportions of the principal parts.

---

## VALVE MOTION.

### PLATE 35.

Although it is hardly within the scope of the subject of mechanical drawing to discuss the valve motion of a steam-engine, it will nevertheless be of advantage to do so, as affording a good example of graphical analysis.

The diagrams on Plate 35 give partial sections of the steam-cylinder,  $\frac{1}{8}$  size, and the valve and seat,  $\frac{1}{4}$  size. Below these are shown circles representing the path of the crank-pin,  $\frac{1}{8}$  size, and the path of the centre of the eccentric,  $\frac{1}{4}$  size.

The relation of the valve-face to the *ports* in the seat can be understood best when the valve is in its central position as shown in Fig. 4, where it will be seen that the inner edges of the valve just close the steam ports by being exactly in line with the inner edges of the latter, while the outer edges of the valve extend beyond or lap over the outer edges of the steam ports  $\frac{9}{32}$ ". This is called the *outside* or *steam lap*. If the inner edges had more than covered the steam-ports, the excess would have been

*inside or exhaust lap*, and if they had not entirely covered the ports, the deficiency would have been *negative inside lap*.

The valve being moved by means of the revolution of the eccentric, it is evident that when the latter is on its top centre the former will be at the top of its motion, and when the latter is on its bottom centre the former will be at the bottom of its motion; consequently, when the valve is in its central position, the eccentric-centre will have moved half-way between top and bottom, and will be on the line  $ab$  at right angles to the axis of the cylinder. This central position of the valve is shown in Fig. 4, where it will be seen that the steam-ports are closed, that there is no inside lap and that there is  $\frac{9}{32}$ " outside lap on each end.

The function of lap will be understood after following the movement during one-half a revolution of the crank. Starting with the crank on its top centre and the piston at the top of its stroke, as shown in Fig. 1, it is evident that the valve must at this moment be in a position to permit steam to enter the cylinder above the piston. It has already been shown that when the valve is in its central position, it extends beyond the port an amount equal to the lap, and that the eccentric is at right angles to the axis of the cylinder. Now, in order to move the valve down sufficiently to begin opening the port, the eccentric must be rotated through an angle the sine of which is proportional to the desired motion. The amount of this motion is equal to the lap plus the required amount of opening of the port at this moment. This opening is called the *lead* of the valve, and in this instance is  $\frac{1}{32}$ ". Therefore the eccen-



tric must be rotated on the shaft through such an angle as will move the valve  $\frac{5}{16}$ ". This angle is called the *angle of advance* of the eccentric, and in this case is  $30^\circ$ .

Fig. 1 shows the crank on its top centre, *C*, the eccentric at *E*, the piston at the point of commencing its down-stroke and the upper steam-port open the amount of the lead. The arrow shows the direction of rotation of the crank. The eccentric is thus at an angle with the crank equal to  $90^\circ$  plus the angle of advance, laid off in the direction of rotation.

The piston now moves down and turns the crank, while the eccentric, being keyed to the crank-shaft, turns with it and draws down the valve, further opening the steam-port. The relative position of the parts when the eccentric has reached the end of its throw, is shown in Fig. 2, where the crank has turned through  $60^\circ$  and the valve has made its widest opening to the steam-port. From here the valve alters its direction and moves upward, reducing the port opening, and then arrives at the position shown in Fig. 3, where the steam-port is just closed and the steam shut off from the cylinder. This is called the *point of cut-off*, that is, the point at which the communication between the cylinder and boiler is shut and the force exerted upon the piston is due alone to the expansion of the steam confined behind it.

By again examining these three Figs. it will be seen that the port communicating with the cylinder-space below the piston has so far been always open, to a greater or less extent, to the interior of the valve, and thence, through the exhaust port, to the

atmosphere, so that the exhaust steam which has done its work in the preceding up-stroke, has had free exit.

With the further rotation of the crank, the valve moves upwards to the central position shown in Fig. 4, where it is on the point of exhausting the steam above the piston and has just closed the exhaust below. This is therefore the final point at which the *expansion* of the steam above the piston is fully utilized, and also the point at which the *compression* of the exhaust steam below the piston commences.

The remainder of the half-revolution of the crank results in opening the top port to the exhaust and in keeping the bottom port closed during the travel of the lap, thus making a period of compression during which the exhaust steam below the piston acts as a cushion to overcome the inertia of the moving parts of the engine, and is brought up to a pressure approximately equal to that in the boiler by the time the valve opens the bottom port to the live steam. When the crank arrives on its bottom centre, Fig. 5, the eccentric-centre is diametrically opposite its first position, Fig. 1, and the valve has opened the bottom port the amount of the lead,  $\frac{1}{8}''$ . The same relative movements will then occur during the up-stroke of the piston, the admission, expansion, and exhaust of the steam below and the exhaust and compression of that above occurring when the crank arrives at positions diametrically opposite those during the down-stroke.

## BILGRAM VALVE DIAGRAM.

### PLATE 36.

The inconvenience and tediousness of the preceding tentative method of analyzing the valve motion, has induced the invention of several diagrams, by means of which the throw of the eccentric and its angular advance and the amount of lap required for the valve, in order to produce such an amount of lead, expansion, and compression as may be desired (within the limitations of the case) can be readily determined by graphical means. The simplest of these is the one devised by Mr. Hugo Bilgram.

In order to get a clear comprehension of the Bilgram Valve Diagram, it will be advisable to first make a diagram of the actual relative motions of the crosshead, connecting-rod, crank, and eccentric centre.

For this purpose draw, upon a sheet 21" by 16", the vertical centre-line of the engine and intersect it by the horizontal centre-line of the crank-shaft, as shown in Fig. 1, Plate 36. About this intersection describe a circle, 8" diameter, scale  $\frac{1}{2}$ , for the path of the centre of the crank-pin. Above the bottom of this circle lay off 20", the length of the connecting-rod, and above this, 8", the movement of the crosshead, which is equivalent to the stroke of the piston. Divide this stroke into 10 equal parts

and subdivide each part. By setting the large dividers to 20'', they can be used for the connecting-rod and the percentage of the stroke through which the piston has traveled can be very closely approximated for any degree of the crank's revolution. Now, concentric with the crank-circle, draw another  $1\frac{1}{4}$ '' diameter, *double-size*, for the path of the eccentric-centre. Two different scales are used for convenience and clearness, half-size for the motions of the crank, connecting-rod and crosshead, because they are large, and double-size for the motion of the eccentric-centre because it is small and requires accuracy.

With the crank on its top centre, locate the eccentric-centre,  $e$ , at the given angle of advance,  $30^\circ$ , with the horizontal centre-line  $ab$  of the shaft. A perpendicular from  $e$  to  $ab$  will give the amount the valve has moved from its central position, which at this point must be equal to the amount of the lap, plus the lead. With a radius equal to the lap,  $\frac{9}{32}$ '', describe a circle about  $e$ , and then the distance between this circle and  $ab$  will be the amount of lead or the opening of the steam port. This circle is called the *lap-circle*, and the distance between it and  $ab$  will show the port opening for steam, in whatever position the eccentric-centre may be. As there is no lap on the exhaust portion of the valve, both ports are just closed to the exhaust when the valve is central or when the eccentric-centre is on  $ab$ , hence the perpendicular distance from  $e$  to  $ab$  will always show the port opening for exhaust.

If now the crank rotates in the direction shown by the arrow,  $e$  will recede from  $ab$ , increasing the opening of the steam-port, until it reaches the vertical centre line,

after which it will advance towards  $a b$ , diminishing the steam opening until the lap circle touches  $a b$ , when the steam will be cut off,  $e^1$  being the position of the eccentric-centre at this moment. To find the corresponding position of the crank, lay off  $e^1 o c^1$  equal to  $e o c$ , or  $120^\circ$ . The bottom exhaust port will at this time be open the amount of the steam-lap,  $\frac{3}{8}''$ , and will be closed when the eccentric-centre arrives at  $e^2$  and the crank at  $c^2$ ,  $e^2 o c^2$  being  $120^\circ$ . When the crank is at  $c^3$ ,  $c^4$  and  $c^5$ , the eccentric will be diametrically opposite  $e$ ,  $e^1$  and  $e^2$  and the port opening can be measured from  $a b$  as before.

One trial will be sufficient to show the awkwardness of this method, even when the throw, angular advance, and lap have been furnished, but its efficiency will be much less when these have to be determined. The trouble with this method is that, although the crank and eccentric bear a constant relation to each other, yet they both move in relation to the horizontal centre-line  $a b$ , which is the *base-line* from which the motion of the valve is determined.

The invention of Mr. Bilgram consisted in making the line of the crank a movable base-line and of locating a *fixed-point* in the path of the eccentric-centre so that the distances from this fixed-point to the line of the crank would be, for every position of the latter, the same as the distances from the real eccentric-centre, when in corresponding positions, to the line  $a b$ . This makes only one moving part to handle instead of two, and greatly simplifies the operation.

Now, alongside of the previous drawing, repeat the circles of the paths of the

crank and eccentric-centres and show the path of the crosshead-pin as before. If the fixed-point  $e$ , is located on the eccentric-circle so that a radial line through it makes an angle equal to the angle of advance,  $30^\circ$ , to the right of the vertical centre line, and the lap-circle is drawn, as shown in Fig. 2, it is evident that when the crank is on its top-centre, the distance from the line of the crank to the lap-circle will be the same as the distance from the lap-circle in Fig. 1 to the horizontal centre-line  $ab$  at right angles to the crank. Also, it is evident that, if the crank be moved through any angle, the perpendicular distance from its line in the new position to the fixed-point  $e$ , will be the same as that from the line  $ab$  to the corresponding position of the eccentric-centre in Fig. 1; because the line of the crank will have had precisely the same motion in relation to the fixed-point in the former case as the eccentric-centre had in relation to  $ab$  in the latter case.

Therefore, draw a radial line making an angle of  $30^\circ$  to the right of the vertical-centre line, and about the point  $e$ , where it cuts the eccentric-circle (which is the *fixed-point*), describe the lap-circle of radius equal to the lap,  $\frac{a}{32}''$ . Tangent to the lap-circle, draw a diameter,  $A A'$ , of the crank-circle, then  $A$  will be the position of the crank-pin when the top steam-port is on the point of opening and  $A'$  its position when the bottom steam-port is on the point of opening. Perpendicular to the radial line of the fixed-point, draw  $B B'$ , then  $B$  will be the crank-position when the top steam-port and bottom exhaust-port are at their widest opening, and  $B'$  its position when the bottom steam-port and top exhaust-port are at their widest opening. The

amount of the widest steam-opening is measured from the centre  $O$  to the lap-circle, and is equal to the throw of the eccentric,  $\frac{5}{8}''$ , minus the lap  $\frac{9}{32}''$ , and is therefore  $\frac{11}{32}''$ . The amount of the widest exhaust-opening is equal to the throw,  $\frac{5}{8}''$ . To find the port-openings for any position of the crank, it is only necessary to draw a diameter in the required position and a perpendicular from this diameter to the fixed-point  $e$ , when the length of this perpendicular to the lap-circle will be the steam-opening, and that to the fixed-point will be the exhaust-opening.

Now draw a diameter  $EE'$  tangent to the lap-circle, then  $E$  will be the position of the crank-pin when the top steam-port is just closed and  $E'$  when the bottom one is closed, thus fixing the points of *cut-off*. The exhaust opening at this moment will be equal to the radius of the lap-circle. A diameter,  $RR'$ , drawn through the fixed-point  $e$ , gives the positions of the crank when the valve is central and the confined steam at one end is about to be released and the exhaust steam at the other end about to be compressed. This fixes the points of *release* and *compression*.

We thus have a means of readily locating the crank for the important points of the valve's motion and of determining the port-openings for any position of the crank. The top-end of the cylinder has been open to steam from the commencement of the stroke until the crank arrived at  $E$ , where it is cut off and expansion begins. The expansion continues to  $R$ , where the steam is released on top and compression begins in the bottom-end.

The lap-circle governs the point of admission and the point of cut-off of the

steam, while the fixed-point  $e$ , governs the points of commencement of exhaust and compression. Hence the *lead* cannot be altered without changing the *cut-off*, and a change in either of these alters the exhaust and compression.

The angular motion of the crank is the same for admission, expansion, exhaust, and compression, during both the down and up-strokes, but the motion of translation of the piston is not the same on account of the action of the connecting-rod. In order to investigate this, take the length of the rod in the large dividers, place the needle-point at  $E$  and describe a small arc cutting the path of the crosshead-pin, which has been laid off in decimal parts of the stroke. It will be found that the piston has moved down .81 of its stroke when the steam is cut off. Then describe a similar arc from  $E'$  and it will be found that the piston has moved up only .74 of the stroke, showing a difference of 7 per cent. in the up and down strokes at the points of cut off, due to the *angularity of the connecting-rod*. Repeat the operation from  $R$  and  $R'$  and it will be found that the points of release and compression are at .945 down-stroke and at .918 up-stroke.

Without entering into a discussion of the advisability of equalizing the cut-off at the expense of equal leads, the utility of the Bilgram Diagram for the purpose will now be investigated.

Repeat (as in Fig. 3) the centre-lines, crank-circle, and eccentric-circle, and the path of the crosshead-pin divided decimally. Let it be required to alter the valve-motion so that the steam will be cut off at .73 of both strokes. Locate the position



of the crosshead-pin at these points and from them describe arcs (of radius equal to connecting-rod), cutting the crank-circle to determine the corresponding positions of the crank  $E$  and  $E'$ . Draw the crank-line for the point of admission at top-end,  $A$ , allowing a small lead, say  $\frac{1}{128}''$ , which can be closely approximated, although the fixed-point is not yet determined. It is now evident that the fixed-point will be on a line bisecting the angle formed by the crank-lines  $A$  and  $E$ . Draw the bisecting-line ( $R C$ ) and it will be found to be at an angle of  $34^\circ$  with the vertical centre-line. This will be the new *angle of advance* to which the eccentric is to be set. About the fixed-point describe a circle tangent to the crank-lines  $E$  and  $A$ , the radius of which will be  $\frac{1}{32}''$ . This is the new and increased steam-lap for *top-end* of valve. About the fixed-point describe a circle tangent to the crank-line  $E'$ , the radius of which will be  $\frac{3}{128}''$ . This is the new and diminished steam-lap for *bottom-end* of valve. The angular advance of the eccentric and the steam-laps of the valve have thus been changed to cause the cut-off to take place at 73 per cent. of the stroke of piston at both ends of the cylinder. This is called *equalizing the cut-off*.

A crank-line drawn tangent to the lap-circle for bottom end will give the position,  $A'$ , of the crank at point of admission, and the length of a perpendicular from the fixed-point  $e$ , to the vertical centre-line minus the lap ( $\frac{3}{128}''$ ) will give the bottom-lead,  $\frac{7}{64}''$ . This shows the effect upon the lead of equalizing the cut-off by making the lap at the bottom of the valve different from that at the top.

To equalize the release and compression, strike the connecting-rod-arc from  $R$

and  $C'$  and it will be found that one is at .926 down-stroke and the other at .90 up-stroke. Lay off .90 down-stroke and .926 up-stroke and find the corresponding crank-lines. Then a small circle, described about the fixed-point tangent to these lines, will have for its radius the amount of inside or exhaust-lap necessary to be given to the lower end of the valve in order to make the points of release and compression the same at both ends of the stroke.

There is one feature of this diagram which is a little puzzling until some familiarity has been obtained with the use of it, and that is, the identification of the opposite positions of the crank in relation to the lap-circles, but reference to the Figs. on Plate 36 will make this clear.

It will be noted that the valve as designed from Fig. 3 would give  $\frac{1}{16}$ " less port-opening at the top-end than originally. In order to overcome this, the eccentric-throw would have to be increased and the laps altered accordingly. To understand this, and for the purpose of reviewing the whole subject, draw a diagram as in Fig. 4 for the designing of a valve-motion for this same engine, which will give  $\frac{1}{32}$ " top port-opening, equalized cut-off at  $\frac{5}{8}$  or .625 stroke, and equalized exhaust and compression. From shaft-centre describe an arc of radius equal to the port-opening, locate the crank-lines for the points of admission and cut-off for the down-stroke, bisect the angle of these crank-lines for the angle-of-advance and find by trial a point on this line from which a circle can be drawn tangent to the crank-lines and to the arc which was drawn of radius equal to the port-opening. This point will be the fixed-point  $e$ , and

a circle described about the shaft-centre and passing through the fixed-point will be the eccentric-circle. Locate the crank-line for cut-off on up-stroke and draw the bottom steam lap-circle. Locate the crank-lines for release and compression and draw the bottom exhaust lap-circle. Measure the diagram for the angle-of-advance, the eccentric-throw, and the valve-laps. The utility of making this part double-size will then become apparent, and also a good idea of the possibilities and limitations of the plain slide-valve will be obtained.

There is a slight error in all these diagrams, due to the angularity of the eccentric-rod, but in ordinary cases the rod is so long in proportion to the throw of the eccentric that it is not taken into account.

The three diagrams give the following proportions, which are arranged symmetrically for the purpose of comparison :

FIG. 2.

Top Steam Lap— $\frac{9}{32}$ "'.  
 Top Exhaust Lap—0.  
 Movement of Valve— $1\frac{1}{4}$ "'.  
 Top lead— $\frac{1}{32}$ "'.  
 Cut-off at .810 down-stroke.  
 Compression at .945 down-stroke.  
 Release at .945 down-stroke.

Bottom Steam Lap— $\frac{9}{32}$ "'.  
 Bottom Exhaust Lap—0.  
 Angular advance— $30^\circ$ .  
 Bottom lead— $\frac{1}{32}$ "'.  
 Cut-off at .735 up-stroke.  
 Compression at .918 up-stroke.  
 Release at .918 up-stroke.

FIG. 3.

Top Steam Lap— $1\frac{1}{32}$ "  
 Top Exhaust Lap—0.  
 Movement of Valve— $1\frac{1}{4}$ "  
 Top lead— $\frac{1}{128}$ "  
 Cut-off at .734 down-stroke.  
 Compression at .90 down-stroke.  
 Release at .926 down-stroke.

Bottom Steam Lap— $\frac{31}{128}$ "  
 Bottom Exhaust Lap— $\frac{9}{128}$ "  
 Angular Advance— $34^{\circ}.21''$   
 Bottom lead— $\frac{7}{64}$ "  
 Cut-off at .734 up-stroke.  
 Compression at .893 up-stroke.  
 Release at .926 up-stroke.

FIG. 4.

Top Steam Lap— $\frac{79}{128}$ "  
 Top Exhaust Lap—0.  
 Movement of Valve— $1\frac{5}{16}$ "  
 Top lead— $\frac{1}{64}$ "  
 Cut-off at .625 down-stroke.  
 Compression at .838 down-stroke.  
 Release at .896 down-stroke.

Bottom Steam Lap— $\frac{61}{128}$ "  
 Bottom Exhaust Lap— $\frac{9}{64}$ "  
 Angular Advance— $41^{\circ}.7''$   
 Bottom lead— $\frac{5}{32}$ "  
 Cut-off at .625 up-stroke.  
 Compression at .853 up-stroke.  
 Release at .896 up-stroke.

## ADJUSTABLE CONNECTING ROD AND ECCENTRIC ROD.

### PLATE 37.

The Connecting-Rod and Eccentric-Rod already drawn for the 6" by 8" Engine possess the merit of simple construction but lack conveniences for taking up wear. Other types, which have such conveniences, are shown on Plate 37.

The crank-end of the connecting-rod is made rectangular and to it is fitted a wrought-iron strap which embraces the brass box (in halves) for the crank-pin. The strap is held in place by a gib and key, which pass through a slot, the gib bearing against one end of the slot in the strap and the key bearing against the other end of the slot in the rod. As the adjoining edges of gib and key are tapering, an adjustment of the strap on the rod can be obtained for the purpose of determining the distance apart of the two half-boxes and of drawing them together as they wear. A set-screw holds the key in the desired position.

The other end of the connecting-rod has a rectangular opening through it, into which are fitted two half-boxes for the crosshead-pin, a block, and a wedge, all of brass. The end box is put through from the front, there being no flanges on top and bottom at back, and is slipped to the end and kept in position by the end flanges.

The next box is then put through from the front. It has flanges on top and bottom of front only. The block is put through from the back. It has flanges on top and bottom of back only and has a vertical tongue which fits a groove in the adjoining box. The wedge fills up the remaining space and serves to adjust the distance apart of the boxes.

The eccentric-rod has a similar rectangular end and hole through it, but it has only the half-boxes without flanges, and the wedge, the forked end of the valve-stem being depended on to keep the parts in place side-ways.

---

## BRASS GLOBE VALVE.

### PLATE 38.

This is a drawing to a scale of 4" to the foot, or  $\frac{1}{3}$  size, of a 11 $\frac{1}{2}$ " Stop Valve for the steam-pipe of the 6" by 8" Engine. All the parts are brass, except the hand-wheel, which is cast-iron.

The valve-seat is in a circular plate,  $\frac{5}{16}$ " thick, concentric with the vertical axis, and in the plane of the horizontal axis of the spherical shell. The seat is conical, the angle of the cone being 90°, or 45° on each side, and extends half through the plate,

the remainder of the opening being cylindrical,  $1\frac{1}{2}$ " diameter. This circular plate is held in the centre of the globe by two cylindrical plates, one up and on the outlet side, and the other down and on the inlet side, each extending far enough around to meet a diagonal plate across the globe. By this means, if the opening in the plate is closed, the communication between the inlet and outlet is shut off. This closure is produced by the valve which fits the conical seat. The stem has a spherical end bearing against the interior of the valve to permit the latter to adjust itself to the seat. A gland is screwed into the valve for the collar on the stem to bear against when lifting. The stem has a square thread, 4 per inch, fitting a nut which is screwed into a cylindrical projection on the globe. This nut has an extension to afford a stuffing-box for preventing leakage of steam. The stuffing-box has a washer at the bottom to act as a seat for the packing and a gland and nut at the top to compress it. The inlet and outlet of the globe are tapped for  $1\frac{1}{2}$ " pipe.

---

## TOOTHED GEARING.

The transmission of motion from one shaft to another, which is parallel to it, is very largely accomplished by means of gear-wheels, which are cylinders with teeth upon their circumferences. In a pair of wheels the teeth of one engage with those of

the other so that the rotation of the one compels that of the other. It is very important that the relative velocities of the two wheels should be uniform, and that the transmission of the force from one to the other should be smooth and free from blows, and that the sliding of the teeth should cause as little loss from friction as possible. All these desirable qualities depend upon the nature and accuracy of the form given to the teeth.

In Fig. X let  $oo'$  be a portion of a line joining the centres of two cylinders  $A$  and  $B$ , arcs of whose circumferences are shown by  $PP, P'P'$ , touching each other at  $p$ , and let the diameter of cylinder  $A$  be one-fourth that of  $B$ . If the friction between these cylinders be sufficient to prevent slip, every movement of the circumference of  $A$  will cause an exactly similar movement of the circumference of  $B$ . This would be the perfection of transmission as regards uniformity of motion and absence of shock. The length of the circumference of  $A$  would move the same length of circumference of  $B$  at the same velocity and with perfect smoothness. As  $A$  is one-fourth the diameter of  $B$ , its circumference is one-fourth the length of that of  $B$ , and it would make four turns to one of  $B$ . This is called the *angular velocity ratio*, and if there is no slip or irregularities of any kind between the circumferences, the ratio is said to be *constant*. The want of sufficient friction between the surfaces, compels the use of teeth, and the problem is to so shape these teeth that they will transmit the required motion and force from one wheel to the other with a constant velocity ratio.



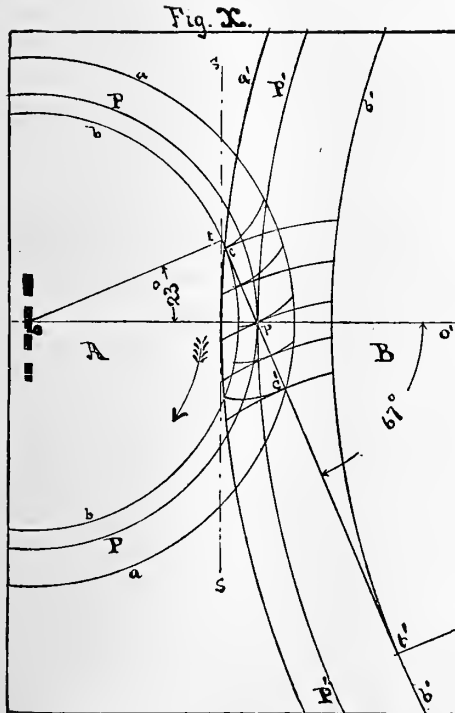

Now reduce the diameters of these cylinders proportionately—that is, so that one shall still be four times that of the other, as shown by  $b b$ ,  $b' b'$ . Wrap an inelastic cord around  $b b$  in the direction shown by the arrow, and then pass it down between the two and around  $b' b'$  in the opposite direction. Then the cord will leave the first cylinder at  $t$  and join the second at  $t'$ , and will cross the line of centres,  $o o'$ , at the original point of contact  $p$ . If either cylinder be now rotated it is clear that the cord will transmit the motion to the other cylinder at the same constant velocity ratio as originally. If a marking-point be fixed to this cord and the cylinders be rotated, the movement of the cord in passing from one cylinder to the other would cause the marking-point to trace an *involute* to each cylinder on a plane perpendicular to the axes, hence, if these two involute curves be used for the shape of

the teeth in the corresponding wheels, such teeth must produce a constant velocity ratio.

Referring to Fig. X, radii drawn from the centres of the wheels, perpendicular to the cord  $t t'$ , will touch the wheels at  $t$  and  $t'$ , the points of tangency of the cord. Suppose the marking-point to be at  $t$  and the wheel  $A$  to turn in the direction shown, then the point will travel along  $t t'$ , tracing an involute from the circle  $b b$ , called the *base-circle* of  $A$ , and at the same time tracing another involute toward the circle  $b' b'$ , called the *base-circle* of  $B$ . Several positions which would be occupied by this one pair of involutes during the movement are shown by the figure. They touch each other only on the line  $t t'$ , which is, therefore, called the *path of contact* or *line of action*, and which is normal to the curves in all positions, and which always passes through the point  $p$ , where the original friction cylinders touch each other. These cylinders,  $P P$ ,  $P' P'$ , are called the *pitch circles*, because the *pitch* of the teeth or the length of the arcs of these circles included between the side of one tooth and the same side of the next, is measured upon them. The point  $p$  is the *pitch-point* where the teeth touch each other on the line of centres.

The pitch is an arc of the pitch-circle which includes a tooth and a space. The tooth acts as a cantilever in transmitting the force from one wheel to the other, and its strength is dependent upon its form, its dimensions, and the material. By whatever system the form is produced it will vary with the radius of the wheel, the root of the tooth becoming smaller and consequently weaker as this radius diminishes.

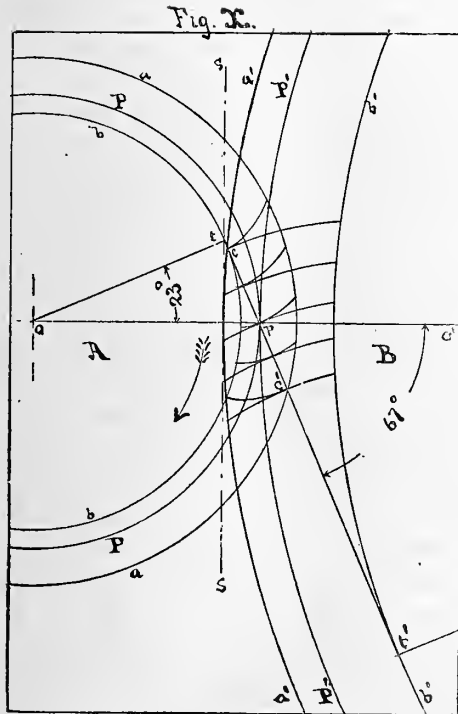

The thickness of the tooth on the pitch-line is necessarily one-half the pitch, less a sufficient amount to allow clearance in the adjoining space for the tooth of the other wheel. The distance which the tooth extends beyond the pitch-circle is called the *addendum*. It is that portion of a radius of the wheel included between the circles  $P$  and  $a$  or  $P'$  and  $a'$ . It determines the length of the cantilever, and should bear a fixed ratio to the pitch to insure interchangeability, uniformity, and convenience of manufacture.

The portion of the involute outside of the pitch-line constitutes what is called the *face* of the tooth, while that inside the pitch-line is the *flank*.

The selection of the best form for the tooth and proportion for the addendum has been subject for dispute from the time of Camus, who first scientifically investigated the subject in 1752, to the present day, but

the author is convinced that the *involute* form with an addendum equal to *three-tenths of the pitch*, and with the smallest number of teeth in any wheel limited to *twelve*, is superior to any other system.

In Fig. X, let the circumference of the pitch-circle,  $PP$ , be divided into twelve equal parts for the pitch, and the radius of the addendum-circle,  $aa$ , be made larger than that of the pitch-circle by an amount equal to  $.3$  pitch. As one tooth touches the other only upon the path of contact,  $t't'$ , it is evident that the action will commence at  $c$ , where  $a'a'$  cuts  $t't'$ , and will end at  $c'$ , where  $aa$  cuts it. If the diameter of  $aa$  were increased,  $c'$  would move further away from  $p$  and more of the involute of  $B$  would be brought into action. The distance,  $pc'$ , would reach its maximum when  $A$  became a rack or wheel of infinite size. So, in the case of  $B$ , an increase in the diameter, of  $a'a'$  ( $A$  remaining as in the Fig.) would move  $c$  from  $p$  until  $a'a'$  arrived at  $s$ , which would be the addendum-line of a rack, and the involutes would commence action at  $t$ , and end at  $c'$ . Hence the line of action of the smallest wheel (12 teeth), gearing into a rack, must pass through the pitch-point,  $p$ , and be tangent to the base-circle,  $bb$ , at the point where the addendum-line,  $ss$ , of a rack cuts it. To find this point,  $t$ , use the triangle, moving it so that one side of its right-angle is in contact with  $p$ , and the other with  $o$ , until the corner touches the line  $ss$ , and draw  $ot$ ,  $t't'$ . The angle,  $t, o, p$ , will be found to be about  $23^\circ$ . Calculation shows it to be  $23^\circ 21'$ , but as the difference will be practically inappreciable, take  $23^\circ$  as the standard angle. The base circles being drawn tangent to the line of action, their radii will be

Fig. 22.

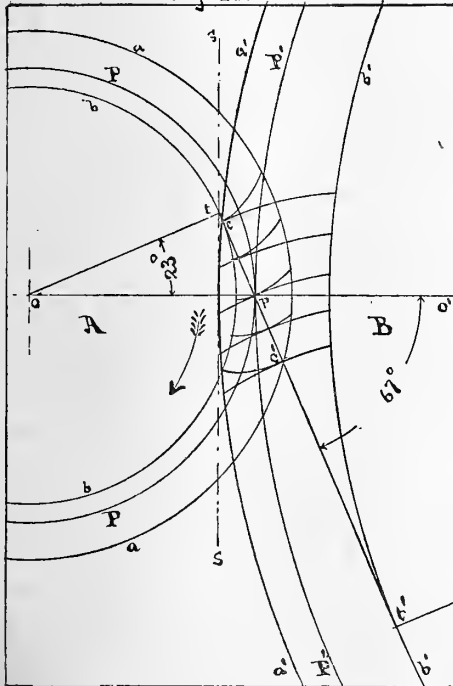

proportional to cosine  $23^\circ$  or  $.92$  radius of pitch-circle, and  $p t$  and  $p t'$  will be proportional to sine  $23^\circ$  or  $.39$  radius of pitch-circle. Hence, to draw this line of action, describe an arc of radius equal to  $.92$  pitch radius from the centre of the wheel and intersect it by an arc of radius equal to  $.39$  pitch radius from the pitch point.

The line of centres divides the path of contact into two parts,  $c p$  and  $p c'$ , and the arc of the pitch-circles which is equivalent to the movement of the point of contact from  $c$  to  $p$ , is called the *arc of approach*, while that equivalent to the movement from  $p$  to  $c'$  is called the *arc of recess*. The sum of these must always be greater than the pitch. Perpendiculars to the line of action, drawn from the points of tangency,  $t$  and  $t'$ , to the pitch-circles, will include the angle of action.

The thrust of the teeth of the wheel A,

upon those of  $B$ , is in the direction of the line of action,  $tt'$ . This is called the *obliquity of action* of the teeth, and the fear of its producing excessive friction in the journals of the wheels has hitherto prevented the adoption of a sensible and correct system of involute gearing. This fear has been induced by the statement, to be found in most works on the subject, that the angle of obliquity should not exceed  $15^\circ$ . With this angle, the number of teeth in the smallest wheel, which will act properly with those in a rack, becomes so great as to render the system useless, unless the faces of the teeth of the large wheels and racks are rounded off to prevent their interference with the flanks of the small wheels, a device which destroys much of the wearing surface and diminishes the length of the path of contact.

Increasing the angle of obliquity to  $23^\circ$  does not affect the efficiency of the gearing, except that it adds a trifling amount to the pressure on the journals, but this sidethrust is constant and steady, and not pulsating, as will be seen farther on to be the case with cycloidal teeth, and the obliquity is actually less than it is at the beginning and end of the arc of action of the latter.

## INVOLUTE GEAR TEETH.

## PLATE 39.

In order to get a clear understanding of the involute form of teeth, it will be well to now make a full-size drawing of the two extreme cases, a pinion of 12 teeth gearing into a rack and into a similar pinion, and also into a wheel of intermediate size, say of 32 teeth. The pitch should be made as large as the drawing facilities will permit. If the standard sheet, 16'' by 21'', is used, the pitch should be  $2\frac{1}{2}$ '', as shown in the Plate.

The pitch being the length of an arc of the pitch-circle included between the side of one tooth and the same side of the next, the pitch-circle will be made up of as many of these arcs as there are teeth; and its circumference will be equal to the product of the pitch by the number of teeth. The ratio of the diameter of a circle to its circumference being 3.1416, if we divide the former product by this number we will obtain the diameter of the pitch-circle, called the *pitch-diameter*. The addendum being .3 pitch, twice this, or .6 pitch, added to the pitch-diameter, will give the *outside-diameter* of the wheel. The depth of the space, below the pitch-line should be made from .35 pitch to .4 pitch. As we are only considering accurately-made teeth, the former amount will be sufficient, and .7 pitch subtracted from the pitch-diameter will give the inside or *root-diameter*.

If  $p$ =pitch,  $n$ =number of teeth,  $P$ =pitch-diameter,  $O$ =outside diameter,  $B$ =root-diameter, and  $\pi=3.1416$ , then.

$$P = \frac{pn}{\pi}, \quad p = \frac{P\pi}{n}, \quad n = \frac{P\pi}{p}.$$

$$O = P + .6p. \quad B = P - .7p.$$

For 12 teeth,  $2\frac{1}{2}''$  pitch,  $P = \frac{2.5'' \times 12}{3.1416} = 9.549''$ ,  $O = 9.549'' + 1.5'' = 11.049''$ , and  $B = 9.549'' - 1.75'' = 7.799''$ .

For 32 teeth,  $2\frac{1}{2}''$  pitch,  $P = \frac{2.5'' \times 32}{3.1416} = 25.465''$ ,  $O = 25.465'' + 1.5'' = 26.965''$ , and  $B = 25.465'' - 1.75'' = 23.715''$ .

With these dimensions, draw the pitch-circles, outside circles, and root circles of the pinions and wheel, and, below the pinion, draw the pitch-line, outside line, and root line for the rack-teeth.

If facilities are not at hand for measuring hundredths of an inch, use the Table of Decimal Equivalents, on page 96, to find the nearest sixty-fourth. For instance, the pitch diameter of the 32-tooth wheel is 25.465''. This will be found by the Table to be .003'' less than  $25\frac{1}{32}''$ .

Next draw the line of action and its normals (shown by heavy lines on the Plate), at angles of  $67^\circ$  and  $23^\circ$ , respectively, with the line of centres, and draw the base-circles tangent to the line of action. The pitch-point divides this line into two portions, the upper belonging to the pinion and the lower to the wheel. Each portion represents a flexible, inelastic cord, wound upon its respective base-circle. If the extremities of the two portions of the cord (represented by the pitch-point) be swung



in and out from the base-circles they will describe involutes which, as we have seen, will be correct shapes for the teeth of these wheels.

To plat these involutes, divide the line between the pitch-point and point of tangency into any number, say three, equal parts, and step off these distances on the base-circles as many times as will be necessary to produce enough involute for the tooth. The three steps taken on the base-circle from the point of tangency, reaching beyond the line of centres, measures where the end of the cord will be when swung in to the base-circle and is the point of origin of the involute. Draw tangents to the base-circle at each of the stepped points, and upon each tangent step the same number of spaces as its point of tangency is from the point of origin. A curve passed through the final points will be the involute required.

The involute for a tooth of any pitch and for a wheel of any size can be very closely approximated by two circular arcs having their centres on the line of action, one arc extending from the pitch-circle out and the other from the pitch-circle in. The length of the radii of these arcs for any number of teeth can be obtained by multiplying the constants given in the Table on page 100, opposite the required number of teeth, by the pitch in inches. In the present case, the radius of face of the 12-tooth pinion will be  $.950$  multiplied by  $2\frac{1}{2}$ , or  $2.375''$ , and the radius of flank will be  $.668 \times 2\frac{1}{2} = 1.67''$ . Describe the face-arc from the pitch-circle to the addendum-circle, and the flank-arc from the pitch-circle to the base-circle, keeping the centre from which each radius is struck always on the line of action. The flank from the base-

circle to the bottom of the space is a radial line. In order to strengthen the root of the tooth, a fillet is made in the corner. This is an arc of a circle tangent to the flank and to the root-circle, and on small wheels should be as large as can be made to clear the engaging tooth. The Table gives the maximum radii of these fillets for 1" pitch for any number of teeth. For any other pitch, multiply the figure in the Table by the given pitch in inches. The radius for this 12-t. pinion will be  $.15 \times 2\frac{1}{2} = .375''$  or  $\frac{3}{8}''$ .

In obtaining the radii for face and flank of the 32-t. wheel, it will be found that the nearest exact figures are for 33 teeth, hence the differences for one tooth, given at the foot of the Table, must be subtracted from the figures given for 33 teeth; thus, radius of face  $= (2.413 - .07) \times 2\frac{1}{2} = 5.858''$ , and radius of flank  $= (1.613 - .045) \times 2\frac{1}{2} = 3.920''$ . Make small circles around the centres on the line of action, from which the face and flank are struck, to facilitate finding them later on.

Now step the pitch around the pitch-circles, using a spring bow dividers with screw adjustment, in order to be able to gauge the alteration which trial may show to be necessary. Then mark the thickness of the teeth on the pitch-line, making it less than half the pitch to give side clearance in the space. This clearance is usually made .02 pitch for cut teeth, and .05 pitch for cast teeth, which makes the tooth and space respectively .49 and .51 pitch for cut teeth, and .475 and .525 pitch for cast teeth.

Having now spaced the teeth, describe circles from the centres of the wheels, pas-

sing through the centres from which the faces and flanks of one tooth have already been described, for the loci of the centres for the faces and flanks of all the other teeth.

The Rack, being a wheel of infinite size, its corresponding involute will be a straight line perpendicular to the line of action, therefore step off the  $2\frac{1}{2}''$  pitch and mark the thickness of the teeth on the pitch-line and, through these marks, draw straight lines making an angle of  $23^\circ$  in opposite directions for the faces and flanks of the teeth.

After completing all the teeth in the wheels, draw lines of action making the same angle,  $23^\circ$ , in the opposite direction from the former ones, in order to see the path of action if the wheels turned in the opposite direction.

Involute teeth in which the angle of action is other than  $23^\circ$  can be drawn in the same manner, by making the line of action at the required angle, drawing the base-circles tangent to it, and generating the involutes from these base-circles, if such teeth are required to meet prejudices which have been handed down, or to maintain systems already adopted, but care must be taken that the addendum-line of the wheel never intersects the base-circle of the pinion beyond the point of tangency of the line of action, as in this case there will be interference between the faces of the teeth of the wheel and the flanks of those of the pinion. To demonstrate this, draw a pinion with 12 teeth, gearing into a rack, with the angle of action  $15^\circ$ , the limit which has usually been assigned to it. Make a tracing of the rack and roll it upon

the pinion, keeping the pitch-lines tangent, and this interference can be seen. With an angle of  $15^\circ$ , the wheel cannot have less than 30 teeth to gear correctly with the rack. This fact destroys the usefulness of the  $15^\circ$  system, and the assertion that the angle should not exceed  $15^\circ$  has consequently prevented any general use of this shape of teeth.

The statement that an obliquity of action exceeding  $15^\circ$  produces an injurious amount of journal friction is an exaggeration, and no fear need be had of using  $23^\circ$  as here recommended. On the contrary, the teeth made on this system will be stronger, will run more quietly, and be more satisfactory in every respect than any other kind.

The greatest reason for the superiority of involute teeth is that they will work together equally well if the pitch-lines are not tangent to each other; that is, the centres of the wheels can be separated a little or be brought closer together without affecting the correct action of the teeth. For instance, if the centres of the pinion and wheel of Plate 39 were each moved  $\frac{1}{16}$ " , one to the right and the other to the left, the base-circles would remain the same in diameter, the pitch-point would stay at the same relative distances from the wheel centres, the pitch-diameters and angle of action would be slightly increased and the addenda decreased, but the velocity-ratio would remain constant and the same as it was before.

This is a very valuable property of involute teeth because it eliminates the bad effects of several errors which are very liable to occur in constructing gearing; namely, the obtaining of accurate diameters for the wheels, the production of cutters which

are correct in relation to the pitch-line, and the cutting of the spaces to the proper depth to bring the point of the curve intended to be at the pitch-line, precisely at it. In addition to these an error is apt to occur in boring the bearings for the journals of the wheels, by not getting them at exactly the correct distance apart.

---

## APPROXIMATE INVOLUTE TEETH.

### PLATE 40.

In drawing the preceding Plate, the exact involutes for one pair of teeth were first generated and the rest of the curves made by circular arcs of the radii given, when it was seen that there was scarcely a perceptible difference between the two. Practically, the error arising from the use of these arcs is less than would occur in attempting to make cutters of absolutely correct shape, except by means of a machine which would automatically generate the curves and form the cutters to them.

For the purpose of getting familiar with the use of the Table on page 100, and of seeing the shapes of teeth made on this system, make a full-size drawing showing a few teeth each in wheels having 12, 20, 27, 33, and 42 teeth of  $2\frac{1}{2}$ " pitch. Draw the line of centres and the pitch-circles, and through each pitch-point draw the line of

action, making an angle of  $67^\circ$  (the complement of  $23^\circ$ ), with the line of centres. Find from the Table, the radii of the flanks and faces for the several different numbers of teeth, and multiply them by the pitch,  $2\frac{1}{2}''$ , for the radii required. Strike the arcs from the pitch-point outward, for the faces, and inward for the flanks, keeping the centres always on the line of action. Lay off the pitches and thickness of teeth on the pitch-lines. From the centres of the wheels, describe circles passing through the centres on the lines of action from which the arcs were struck, and upon these circles take the centres for the arcs of all the other teeth in each wheel. This will be found a convenient, quick, and remarkably close approximation to the true involutes.

Of course, if any other angle of action than  $23^\circ$  is used, the figures in the Table will not apply.

It will be noted that these figures are not given for all numbers of teeth beyond 18. This is done to enable a complete set of wheels to be cut by a limited number of cutters, without any very serious error arising therefrom. Prof. Willis first suggested this, and proportioned the intervals so that the error, between the smallest and largest number of teeth in each interval would be the same. For instance, if a wheel with 49 or 72 teeth is made with a cutter of the proper shape for 58 teeth, the error will be the same as in a wheel with 37 or 48 teeth made with a cutter proper for 42.

If the exact radii for any of the intermediate numbers are required, they can be readily obtained by the use of the differences given at the foot of the Table. The radius of the face for 1'' pitch increases .07'' for each tooth, and of the flank .045''.

The locus of the centres of the radii of the faces is a straight line, as is also that of the flanks, but these lines are neither parallel to each other nor perpendicular to the lines of action.

By means of the following formulæ, in which  $R$ =radius of pitch-circle, the radii for teeth of 1" pitch can be obtained, when the angle of obliquity is  $23^\circ$ .

$$\text{Radius of Face} = .175 (R + 0.66'')$$

$$\text{Radius of Flank} = .113 (R + 1.14'')$$

## DIAMETRICAL PITCH.

### PLATE 41.

As the length of the circumference of the pitch-circle of a gear-wheel is the product of the pitch by the number of teeth, and as the ratio of this circumference to its diameter is 3.1416, it follows that if the pitch is an even measurement, the diameter will be decimal, and if the diameter is made even the pitch will become decimal. It also follows that the number of teeth is proportional to the diameter. If a wheel 5" pitch diameter has 20 teeth, one of 10" will have 40 teeth, and they will each

have 4 teeth for every inch of diameter, while the circumferential pitch will be  $\frac{3.1416}{4}$  or .7854''

This method of indicating the pitch, by specifying the number of teeth per inch of diameter, is often a convenience in making calculations, and in enabling the distance between the centres of the wheels to be made to coincide with the system of measurements in common use. The pitch is expressed as thus: 4 per inch, or No. 4 pitch. The Table on page 99 contains a column of diametral pitches with the corresponding actual pitches, arranged in proper order in relation to the usual pitches which contain vulgar fractions. It also gives the addendum outside and the depth inside the pitch-line, the former being .3 pitch and the latter .35 pitch.

A system is largely used in which the addendum is made equal to  $\frac{1}{\text{No. of teeth per inch of diam.}}$  For instance, the addendum for No. 4 pitch is  $\frac{1}{4}$ '', for No. 8 pitch,  $\frac{1}{8}$ '', and so on. This makes the addendum equal to  $\frac{1}{p}$  p, or .3173 pitch, which would necessitate an increase of the angle of action to  $24^\circ$ .

The advantage of using exclusively the diametral-pitch system has been very much overrated, for unless it is restricted to 16, 8, 4, 2 and 1 per inch, the vulgar fractions become troublesome and liable to cause mistakes in the shop, while its convenience is not much greater than that of the Table on Page 99. The fifth column in that Table gives figures which, multiplied by any given number of teeth of any pitch, will give the required pitch diameter, to which is to be added twice the adden-



dum, and from which is to be subtracted twice the depth (as found on the same horizontal line) for the outside and root diameters respectively.

The fear of decimal measurements for shop use is unfounded, because, with a little experience, they can be as conveniently and accurately made as the ordinary ones. It is much better to accept the decimals unconditionally, than to devise incorrect or mongrel systems of gearing in order to avoid them.

---

## PROPORTIONS OF GEAR WHEELS.

Plate 41 is to be drawn as an example of an arm-wheel, a plate-wheel, and a pinion, in order to become acquainted with a good conventional method of showing them, with the proportions to be given to the various parts, and with diametral pitch.

Draw the centre-lines, the pitch-circles, the outside-circles, and the root-circles for 80, 49, and 12 teeth, 8 per inch. Make the width of face of the wheels, in the top-view, from 2 to  $2\frac{1}{2}$  times the pitch or, in this case, 1". Make the top-view in section, presuming that the section does not cut the teeth, and show the pitch-lines and tops and bottoms of teeth as in the Plate. This is easier and very much clearer than attempting to find where the central plane would cut a tooth. In the front-view, make the pitch-circles blue, the root-circles dotted, and the outside-circles full, except

where they run together. Make the thickness of the rim below the bottoms of the teeth equal to about  $\frac{5}{8}$  the pitch, and the depth of the web below this about equal to the pitch, if the wheel has arms. Make the width of the arms at the web from  $1\frac{1}{2}$  to 2 times the pitch, according to the number of teeth, say  $1\frac{1}{2}$  times for 25 teeth, and 2 times for 100 teeth. Taper the width of the arms from  $\frac{1\frac{1}{8}}{4}$ " to  $\frac{3}{4}$ " per foot of length, and make their thickness equal to .4 their width. The thickness of the web is the same as that of the arms which join it. In plate-wheels, make the thickness of the plate about .6 pitch. Make the diameter of the hub from  $1\frac{3}{4}$  to 2 times the diameter of the shaft, and the length of the hub not less than  $1\frac{1}{4}$  times the diameter of the shaft.

Make this drawing full-size, marking the dimensions as shown, and giving the tooth-data in columns, apart from the lines of the drawing, for the sake of clearness.

---

## CYCLOIDAL GEAR TEETH.

### PLATE 42.

Although involute teeth, properly designed and constructed, possess decided practical advantages over the cycloidal, the action of the latter is perfect if their form and the coincidence of their pitch-lines are perfect. An understanding of this

form of tooth is, therefore, important, particularly as it is in more general use than the other.

If a circle is rolled on a straight line, a point on its circumference will trace a curve, which is called a *cycloid*. If rolled on the outside of another circle, the curve generated is called an *epicycloid*, and if rolled on the inside, it is called a *hypocycloid*.

Draw the pitch-lines of a pinion of 12 teeth gearing into a rack and also into a wheel of 32 teeth,  $2\frac{1}{2}$ " pitch, as shown in Plate 42. Draw the rolling-circles, of diameter equal to half that of the pinion, tangent to the pitch-circles, and to each other at the pitch-point. Imagine the wheels and rolling-circles to revolve about their fixed centres with a uniform velocity-ratio. Take the pitch-point as the marking point of the rolling-circle on the outside of the pinion and the inside of the wheel. This marking point will move along the circumference of the rolling-circle and, in doing so, will trace an epicycloid from the pitch-circle of the pinion outward, and a hypocycloid from that of the wheel inward. As these two curves are both generated by the same point, at the same time, they must be tangent to each other at every position in the path of the point, and as the velocity-ratio of all the circles is constant, that produced by the action of the two curves upon each other must also be constant. If this is true in one case, it is in all, and curves generated by this means are proper forms for the teeth of wheels.

As regards the correct action of the teeth of any individual pair of wheels, the diameter of the rolling-circles is a matter of indifference, provided the same circle is

used to generate the faces of the teeth of one wheel and the flanks of the other, but as interchangeability is desirable and essential, it is necessary that the same rolling-circle be used for all wheels whose teeth are of the same pitch.

If the rolling-circle is one-half the diameter of the wheel inside of which it rolls, the hypocycloid generated thereby will be a radial line. Experience has shown that the flanks of the teeth should never be made thinner than would be produced by radial lines; therefore, if a pinion with 12 teeth be taken as the smallest allowable wheel, a rolling-circle of half its diameter will make the flanks of its teeth radial and will be the proper one to use for all wheels of its pitch.

To describe the curves, set the spring bow dividers to any distance, say  $\frac{1}{2}$  pitch, and step this distance on the pitch-lines. Draw the paths of the centres of the rolling-circles, and draw normals to the pitch-lines from the stepped points, to intersect these paths. Strike arcs of the rolling-circles from the points thus found, and step back on each arc the distance from the pitch-point to the point of tangency of the arc with the pitch-circle, being careful that the original distance taken in the dividers has not been changed. Curves passed through the final-points will give the shape required. Then draw the outside and root-circles and mark off the pitch and thickness of teeth upon the pitch-lines. Use  $.3$  pitch for the addendum and  $.35$  pitch for depth as before.

To avoid the difficulty of repeating the cycloidal-curves for every tooth, find centres from which to strike circular arcs to approximate these curves and draw the

loci of these centres, from which the arcs of all the teeth can be quickly struck. Circular arcs will not approximate very closely to the true curves, but the accuracy is sufficient for purposes of drawing, and is much greater than is attained in teeth shaped by any "rule of thumb." Many systems have been devised for finding centres and radii for these arcs, the one in most general use being Professor Willis' Odontograph. Professor Renleaux's graphical method is also very good. The closest approximation, however, is obtained by constructing the cycloidal-curves for the several numbers of teeth of large pitch, and determining graphically the centres and radii of arcs to pass through three (the central and two extreme) points of the working-part of the curves.

The figures for cycloidal teeth in the Table on page 100 have been found in this manner, and from it can be obtained the distance *inside* of the pitch-line for the line of centres for the *faces*, and the distance *outside* of the pitch-line for the line of centres for the *flanks*, and also the radii of the faces and flanks, by multiplying the corresponding figures in the Table by the pitch in inches.

These arcs are flatter near the pitch-point and fuller near the addendum and root-points than the true curves, particularly for small numbers of teeth, and are not as close an approximation as those for involute teeth, while the nature of the former requires greater accuracy than that of the latter.

After completing this drawing (Plate 42) of cycloidal teeth, it will be seen that the path of contact, which comprises arcs of the opposite rolling-circles included within the two opposite addendum-lines, shown by heavy lines in the Plate, is inflexi-

ble, requiring exact coincidence of the pitch-lines and exact relation between the curves, radially, which is very difficult to attain. It will also be seen that the obliquity of action at the commencement and end of the path is as great as in the  $23^\circ$  involute. The weight of evidence, both from experience and analysis, is getting on the side of involute teeth, and it would be very desirable if the best possible system could be established and universally adopted.

---

## BEVEL GEARS.

### PLATE 43.

The cylindrical wheels, which have so far been considered, can be used for transmitting motion from one shaft to another, only when these shafts are parallel.

If the axes intersect, the pitch-surfaces must be *cones* instead of cylinders, the apices of the cones being at the point of intersection. Wheels having conical pitch-surfaces are called *bevel wheels*. The usual case is where the axes are at right angles, although the principle is the same in all cases.

The *pitch-cones* are sectors of a sphere, their axes intersect at the centre of the sphere, and their lines of tangency are elements of their surfaces, which all meet at the

intersection of their axes. Their velocity-ratio is independent of the diameter of the imaginary sphere ; that is to say, if the sphere is enlarged and the angles of the cones remain the same, the velocity-ratio will remain the same, because the diameters of the sectors will increase proportionately. These diameters are the pitch-diameters of the bevel wheels, and are calculated in the same way as for cylindrical wheels, so that the pitch-circles of bevel wheels are the circles of the sphere formed by the sectors or pitch-cones. If the pitch and thickness of the teeth be laid off on these circles, each pitch-point will be the extremity of an element of the conical surfaces, which all converge to the centre of the sphere. To produce bevel gears from these pitch-cones involves the same principles as have been investigated for the production of spur-wheels from their pitch-cylinders, but the operation becomes very much complicated, theoretically, from the fact that the rolling of the generating line for describing the teeth should be done upon conical surfaces instead of cylindrical. If, for instance, the teeth are to be cycloidal, their shapes should be generated by rolling a sector on the outside of one pitch-cone and on the inside of the other and *vice versa*, when the element of the surface of the rolling sector, which coincided with the pitch-point at the start, would generate cycloidal teeth, every element of which would converge to the centre of the sphere, the shape of the teeth appearing on the surface of the sphere, where their size would be the greatest, from whence it would diminish to a point at the centre.

The complication and difficulty of this treatment of the subject is avoided, with-

out any appreciable error, by substituting for the sphere cones tangent to it at the circles of the pitch-sectors, and then developing these cones and treating them the same as spur-wheels.

This will be best understood by making a drawing of a pair of bevel wheels  $1\frac{1}{4}$ " pitch, the pinion to have 15 teeth and the wheel 20.

Draw the axes of the wheels at right angles to each other, and lay off the pitch-diameters, 5.968" and 7.958", as shown in Plate 43. Connect the extremities of these diameters with the intersection of the axes, for the pitch-cones. On these lines, lay off the length of the teeth,  $2\frac{1}{2}$ ", and draw perpendiculars extending to the axes. These perpendiculars will represent the tangent-cones; that is, they will be tangent to the imaginary sphere and normal to the pitch-cones. The development of portions of these tangent-cones will result in arcs of circles, one pair for the outside end of the teeth, and the other pair for the inside end, which can then be treated precisely as pitch-circles of spur-wheels, and involute or cycloidal teeth be generated upon them by any system desired.

The actual production of theoretically correct teeth for bevel wheels is difficult, because every element of them should converge to the intersection of the axes. They can be produced by a reciprocating cutting point, one end of whose guide oscillates about the apex of the pitch-cone, while the other end is moved in the required path to produce the shape of the tooth. This was well illustrated by Mr. George H. Corliss' cycloidal bevel-gearing at the Centennial Exhibition of 1876, but is applica-



ble only to large teeth. Mr. Hugo Bilgram has discovered a principle, and invented a machine by which perfect involute teeth of small pitch can be cut. With ordinary machine-shop appliances, however, the best that can be done, in cutting teeth of bevels, is to make the flanks radial lines, and approximate the curve of the faces. This introduces another system of cycloidal teeth, which is equally applicable to spur-wheels when not required to be interchangeable.

It has been shown that, if the rolling-circle is half the diameter of the pitch-circle, the resultant hypocycloid will be a radial line, and also that the proper epicycloid to work with this should be generated by the same rolling-circle, hence, if we roll on the outside of the developed arc of the tangent cone of the pinion, a circle of half the diameter of the development of the tangent cone of the wheel, and *vice versa*, we will produce faces of proper cycloidal form to gear with the radial flanks.

Draw the developed arcs of the tangent-cones and the rolling-circles, lay off the pitches, and construct the shapes of the large end of the teeth as shown.

The path of contact of the teeth comprises the portions of the arcs of the rolling-circles included within the addendum-circles as before, and it will be noted that the obliquity of action is less than in the system formerly explained, but that the action is confined to a smaller surface of the tooth, thereby causing more concentrated wear and earlier distortion of the shape. The disadvantage of greater obliquity of action is more than counterbalanced by the additional wearing surface obtained by it.

After generating the face of one tooth, find by trial the radius and centre of a circular arc to approximate it, and complete several teeth.

The shape of the inside end of the teeth is produced in the same manner by developing the tangent-cones at that point. The pitch, addendum, depth, radius of approximate arc, and everything at the small end, are in the same proportion to those of the large end, as the distance from the apex to the pitch-point of the large end, is to the distance from the apex to the pitch-point of the small end. To find any of these, strike arcs from the apex as centre, tangent to both ends of the teeth, when any dimension laid off on the one, will be determined by a radial line cutting the other.

The developed arcs of the tangent cones are to be treated precisely the same as pitch-circles of cylindrical gears of the same diameters as these arcs, and not as pitch-diameters of the bevel-wheels. The shape of tooth is to be produced in the same manner, limited and governed only by possibilities of construction. The student should draw bevel-gears in which the ratio of the pitch-diameters are different, and also a pair in which the axes are not at right angles, one pair with involute teeth ( $23^\circ$ ), and one with cycloidal teeth with curved flanks, after which no difficulty need be apprehended in handling the subject.

Plate 43 is deficient in dimensions for shop use, both for turning the wheels and for cutting the teeth, although everything is fully determined as far as the drawing is concerned. For shop purposes there should be given the diameter of the outside corners and the angles of the outside and root of the teeth.

## CONCLUSION.

Any student who has carefully, accurately, and thoughtfully made the drawings of these Courses should, if he has had the advantage of any scientific or technical education, be capable of creditably handling any problem that might arise. The variety of these problems is infinite, but they can all be analyzed into comparatively simple details, and if the training derived from the examples which have been explained, tends to make the path easier in other or more difficult cases, the purpose of the books has been attained.

## DECIMAL EQUIVALENTS

OF 8THS, 16THS, 32DS, AND 64THS OF AN INCH.

FRACTION of an inch.	DECIMAL of an inch.	FRACTION of an inch.	DECIMAL of an inch.	FRACTION of an inch.	DECIMAL of an inch.	FRACTION of an inch.	DECIMAL of an inch.
$\frac{1}{64} =$	.015625	$\frac{17}{64} =$	.265625	$\frac{33}{64} =$	.515625	$\frac{49}{64} =$	.765625
$\frac{1}{32} =$	.03125	$\frac{9}{32} =$	.28125	$\frac{17}{32} =$	.53125	$\frac{25}{32} =$	.78125
$\frac{3}{64} =$	.046875	$\frac{19}{64} =$	.296875	$\frac{35}{64} =$	.546875	$\frac{51}{64} =$	.796875
<b>1-16</b> =	.0625	<b>5-16</b> =	.3125	<b>9-16</b> =	.5625	<b>13-16</b> =	.8125
$\frac{5}{64} =$	.078125	$\frac{21}{64} =$	.328125	$\frac{37}{64} =$	.578125	$\frac{53}{64} =$	.828125
$\frac{3}{32} =$	.09375	$\frac{11}{32} =$	.34375	$\frac{19}{32} =$	.59375	$\frac{27}{32} =$	.84375
$\frac{7}{64} =$	.109375	$\frac{23}{64} =$	.359375	$\frac{39}{64} =$	.609375	$\frac{55}{64} =$	.859375
<b>1-8</b> =	.125	<b>3-8</b> =	.375	<b>5-8</b> =	.625	<b>7-8</b> =	.875
$\frac{9}{64} =$	.140625	$\frac{25}{64} =$	.390625	$\frac{41}{64} =$	.640625	$\frac{57}{64} =$	.890625
$\frac{5}{32} =$	.15625	$\frac{13}{32} =$	.40625	$\frac{21}{32} =$	.65625	$\frac{29}{32} =$	.90625
$\frac{11}{64} =$	.171875	$\frac{27}{64} =$	.421875	$\frac{43}{64} =$	.671875	$\frac{59}{64} =$	.921875
<b>3-16</b> =	.1875	<b>7-16</b> =	.4375	<b>11-16</b> =	.6875	<b>15-16</b> =	.9375
$\frac{13}{64} =$	.203125	$\frac{29}{64} =$	.453125	$\frac{45}{64} =$	.703125	$\frac{61}{64} =$	.953125
$\frac{7}{32} =$	.21875	$\frac{15}{32} =$	.46875	$\frac{23}{32} =$	.71875	$\frac{31}{32} =$	.96875
$\frac{15}{64} =$	.234375	$\frac{31}{64} =$	.484375	$\frac{47}{64} =$	.734375	$\frac{63}{64} =$	.984375
<b>1-4</b> =	.25	<b>1-2</b> =	.5	<b>3-4</b> =	.75		

## STANDARD PROPORTIONS FOR BOLTS AND NUTS.

Diameter of Screw.	Threads per inch.	Diameter at Root of Thread.	Width of Flat.	Short Diameter of Head and Nut.	Long Diameter of Hexagon.	Thickness of Head and Nut.	Diameter of Washer.	Thickness of Washer.
1	20	.185	.0062	$\frac{7}{16}$	.505	$\frac{3}{16}$	$\frac{9}{16}$	$\frac{3}{32}$
$\frac{5}{16}$	18	.240	.0074	$\frac{17}{32}$	.613	$\frac{1}{4}$	$\frac{11}{16}$	$\frac{1}{8}$
$\frac{3}{8}$	16	.294	.0078	$\frac{5}{8}$	.722	$\frac{5}{8}$	$\frac{13}{16}$	$\frac{1}{8}$
$\frac{7}{16}$	14	.344	.0089	$\frac{23}{32}$	.830	$\frac{15}{8}$	$\frac{15}{8}$	$\frac{3}{8}$
$\frac{1}{2}$	13	.400	.0096	$\frac{13}{16}$	.938	$\frac{7}{8}$	$1\frac{1}{8}$	$\frac{3}{8}$
$\frac{9}{16}$	12	.454	.0104	$\frac{11}{8}$	1.046	$\frac{7}{4}$	$1\frac{1}{4}$	$\frac{3}{8}$
$\frac{5}{8}$	11	.507	.0113	1	1.154	$\frac{9}{8}$	$1\frac{3}{8}$	$\frac{3}{4}$
$\frac{3}{4}$	10	.620	.0125	$1\frac{1}{8}$	1.371	$\frac{11}{8}$	$1\frac{9}{8}$	$\frac{1}{2}$
$\frac{7}{8}$	9	.731	.0138	$1\frac{3}{8}$	1.587	$\frac{13}{8}$	$1\frac{11}{8}$	$\frac{1}{2}$
<b>1</b>	8	.837	.0156	$1\frac{9}{8}$	1.804	$\frac{15}{8}$	$2\frac{1}{8}$	$\frac{5}{16}$
$1\frac{1}{8}$	7	.940	.0178	$1\frac{7}{4}$	2.020	$1\frac{1}{2}$	$2\frac{1}{8}$	$\frac{5}{16}$
$1\frac{1}{4}$	7	1.065	.0178	$1\frac{5}{8}$	2.237	$1\frac{3}{8}$	$2\frac{9}{16}$	$\frac{5}{16}$
$1\frac{3}{8}$	6	1.160	.0208	$2\frac{1}{8}$	2.453	$1\frac{5}{8}$	$2\frac{3}{8}$	$\frac{5}{16}$
$1\frac{1}{2}$	6	1.284	.0208	$2\frac{5}{16}$	2.670	$1\frac{7}{8}$	$3\frac{1}{8}$	$\frac{5}{16}$
$1\frac{5}{8}$	$5\frac{1}{2}$	1.389	.0227	$2\frac{3}{8}$	2.886	$1\frac{9}{8}$	$3\frac{9}{16}$	$\frac{3}{8}$
$1\frac{3}{4}$	$5\frac{1}{2}$	1.491	.0250	$2\frac{11}{16}$	3.103	$1\frac{11}{8}$	$3\frac{9}{16}$	$\frac{3}{8}$
$1\frac{7}{8}$	5	1.616	.0250	$2\frac{6}{8}$	3.319	$1\frac{3}{4}$	$3\frac{3}{8}$	$\frac{3}{8}$
<b>2</b>	$4\frac{1}{2}$	1.712	.0277	$3\frac{1}{8}$	3.536	$1\frac{5}{8}$	$4\frac{1}{8}$	$\frac{3}{8}$
$2\frac{1}{4}$	$4\frac{1}{2}$	1.962	.0277	$3\frac{7}{16}$	3.969	$2\frac{3}{16}$	$4\frac{1}{8}$	$\frac{3}{8}$
$2\frac{1}{2}$	4	2.176	.0312	$3\frac{1}{2}$	4.402	$2\frac{7}{16}$	$5\frac{1}{8}$	$\frac{1}{2}$
$2\frac{3}{4}$	4	2.426	.0312	$4\frac{1}{8}$	4.835	$2\frac{11}{16}$	$5\frac{9}{16}$	$\frac{1}{2}$
<b>3</b>	$3\frac{1}{2}$	2.629	.0357	$4\frac{7}{16}$	5.268	$2\frac{13}{16}$	$6\frac{1}{16}$	$\frac{1}{2}$

# WROUGHT-IRON WELDED STEAM, GAS, AND WATER PIPE.

TABLE OF STANDARD SIZES AND DIMENSIONS.

Nominal Inside Diameter.	Actual Inside Diameter.	Actual Outside Diameter.	Thickness.	Internal Circumference.	External Circumference.	Length of Pipe per Square foot of Inside Surface.	Length of Pipe per Square foot of Outside Surface.	Internal Area.	External Area.	Length of Pipe containing One Cubic Foot.	Nominal Weight per cent of Length.	No. of Threads per inch of Screw.	Contents of One foot in Length.
Inches.	Inches.	Inches.	Inches.	Inches.	Inches.	Feet.	Feet.	Sq. Ins.	Sq. Ins.	Feet.	Pounds.		Gallons.
$\frac{1}{8}$	.27	.40	.07	.84	1.27	14.15	9.44	.06	.12	2500.	.24	27	.002
$\frac{1}{4}$	.36	.54	.08	1.14	1.69	10.50	7.07	.10	.22	1385.	.42	18	.002
$\frac{3}{8}$	.49	.67	.09	1.55	2.12	7.67	5.65	.19	.35	751.5	.56	18	.005
$\frac{1}{2}$	.62	.84	.10	1.95	2.65	6.13	4.50	.30	.55	472.4	.84	14	.010
$\frac{5}{8}$	.82	1.05	.11	2.58	3.29	4.63	3.63	.53	.86	270.	1.12	14	.023
1	1.04	1.31	.13	3.29	4.13	3.67	2.90	.86	1.35	166.9	1.67	11 $\frac{1}{2}$	.040
$1\frac{1}{4}$	1.38	1.66	.14	4.33	5.21	2.76	2.30	1.49	2.16	96.25	2.24	11 $\frac{1}{2}$	.063
$1\frac{1}{2}$	1.61	1.9	.14	5.06	5.96	2.37	2.01	2.03	2.83	70.65	2.68	11 $\frac{1}{2}$	.091
2	2.06	2.37	.15	6.49	7.46	1.84	1.61	3.35	4.43	42.36	3.61	11 $\frac{1}{2}$	.163
$2\frac{1}{2}$	2.46	2.87	.20	7.75	9.03	1.54	1.32	4.78	6.49	30.11	5.74	8	.255
3	3.06	3.5	.21	9.63	10.96	1.24	1.09	7.38	9.62	19.49	7.54	8	.367
$3\frac{1}{2}$	3.56	4.	.22	11.14	12.56	1.07	.95	9.83	12.56	14.56	9.00	8	.500
4	4.02	4.5	.23	12.64	14.13	.94	.84	12.73	15.90	11.31	10.66	8	.652
$4\frac{1}{2}$	4.50	5.	.24	14.15	15.70	.84	.76	15.93	19.63	9.03	12.34	8	.826
5	5.04	5.56	.25	15.84	17.47	.75	.62	19.99	24.29	7.20	14.50	8	1.02
6	6.06	6.62	.28	19.05	20.81	.63	.57	28.88	34.47	4.98	18.76	8	1.46
7	7.02	7.62	.30	22.06	23.95	.54	.50	38.73	45.66	3.72	23.27	8	2.00
8	7.98	8.62	.32	25.07	27.09	.47	.44	50.03	58.42	2.88	28.18	8	2.61
9	9.00	9.68	.34	28.27	30.43	.42	.39	63.63	73.71	2.26	33.70	8	3.30
10	10.01	10.75	.36	31.47	33.77	.38	.35	78.83	90.79	1.80	40.06	8	4.08
11	11.	11.75	.37	34.55	36.91	.34	.32	95.03	108.43	1.50	45.	8	4.93
12	12.	12.75	.37	37.70	40.05	.32	.30	113.09	127.67	1.27	48.98	8	5.87
13	13.25	14.	.37	41.62	43.98	.29	.27	137.88	153.94	1.04	53.92	8	6.89
14	14.25	15.	.37	44.76	47.12	.27	.25	159.48	176.71	.90	57.89	8	8.00
15	15.40	16.	.28	48.48	50.26	.25	.24	187.04	201.06	.77	66.00	8	9.18
16	16.40	17.	.30	51.52	53.41	.23	.23	211.24	226.98	.68	70.00	8	10.44
17	17.30	18.	.34	54.41	56.55	.22	.21	235.61	254.47	.61	75.00	8	11.79

## PROPORTIONS OF TEETH OF GEARS.

No. of Teeth per inch of Diam'ter	Pitch.	Addendum outside of Pitch Line (.3 pitch).	Depth inside of Pitch Line (.35 pitch).	Pitch Diam. equals No. of Teeth Multiplied by	No. of Teeth per inch of Diameter.	Pitch.	Addendum outside of Pitch Line (.3 pitch).	Depth inside of Pitch Line (.35 pitch).	Pitch Diam. equals No. of Teeth Multiplied by
	$\frac{1}{4}$	.075	.0875	.079577	3	1.0472	.314	.3665	$\frac{1}{3}$
12	.2618	.079	.0916	$\frac{1}{12}$		$1\frac{1}{8}$	.338	.3937	.358099
11	.2856	.086	.0999	$\frac{1}{11}$	$2\frac{3}{4}$	1.1424	.343	.3998	$\frac{4}{11}$
10	.31416	.094	.1099	$\frac{1}{10}$		$1\frac{1}{4}$	.375	.4375	.397887
9	.34906	.104	.1221	$\frac{1}{9}$	$2\frac{1}{2}$	1.25664	.377	.4398	$\frac{2}{9}$
	$\frac{3}{8}$	.113	.1312	.119366		$1\frac{3}{8}$	.413	.4812	.437676
8	.3927	.118	.1374	$\frac{1}{8}$		$1\frac{1}{2}$	.450	.525	.477465
7	.4477	.134	.1567	$\frac{1}{7}$	2	1.5708	.471	.5498	$\frac{1}{2}$
	$\frac{1}{2}$	.150	.175	.159155		$1\frac{3}{4}$	.525	.6125	.557042
6	.5236	.157	.1833	$\frac{1}{6}$		2	.600	.70	.63662
	$\frac{9}{16}$	.169	.1969	.179049	$1\frac{1}{2}$	2.0944	.625	.7330	$\frac{2}{3}$
	$\frac{5}{8}$	.188	.2187	.198944		$2\frac{1}{4}$	.675	.7875	.716197
5	.62832	.189	.2199	$\frac{1}{5}$		$2\frac{1}{2}$	.750	.875	.795775
	$\frac{3}{4}$	.225	.2625	.238732		$2\frac{3}{4}$	.825	.9625	.875352
4	.7854	.236	.2749	$\frac{1}{4}$		3	.900	1.05	.95493
	$\frac{7}{8}$	.262	.3062	.278521	1	3.1416	.942	1.0995	1
$3\frac{1}{2}$	.89714	.269	.3140	$\frac{2}{7}$		$3\frac{1}{4}$	.975	1.1375	1.034047
	1	.300	.35	.31831		$3\frac{1}{2}$	1.050	1.225	1.114085

*Table for the Shapes of Gear-Teeth of One Inch Pitch by Approximate Circular Arcs.*

**MULTIPLY THESE FIGURES BY THE PITCH IN INCHES.**

INTERVALS OF CUTTERS.		INVOLUTE.			CYCLOIDAL.				
		Centres on 23° Line of Action.		Maximum Radius of Fillet.	Faces.		Flanks.		
		Radius of Face.	Radius of Flank.		Radius.	Distance of centre inside of Pitch Line.	Radius.	Distance of centre outside of Pitch Line.	
Exactly correct for No. of Teeth.	Approximately correct for No. of Teeth.								
12		.950	.668	.15	.59	.016	∞	∞	
13		1.020	.713	.15	.62	.02	5.78	4.00	
14		1.090	.758	.125	.64	.02	4.38	2.70	
15		1.160	.803	.125	.66	.025	3.83	2.22	
16		1.229	.848	.125	.68	.03	3.40	1.80	
17		1.299	.893	.125	.685	.03	2.65	.93	
18		1.368	.938	.125	.695	.03	2.26	.83	
20	19- 21	1.508	1.028	.1	.70	.03	1.84	.56	
23	22- 24	1.717	1.163	.1	.72	.04	1.60	.41	
27	25- 29	1.995	1.343	.075	.73	.04	1.50	.34	
33	30- 36	2.413	1.613	.05	.76	.045	1.42	.30	
42	37- 48	3.040	2.017	.0375	.77	.05	1.25	.22	
58	49- 72	4.154	2.736	.0375	.83	.065	1.04	.13	
97	73-144	6.870	4.490	.0375	.90	.075	1.00	.12	
200	145-300	14.042	9.02	.0375	.91	.08	.96	.11	
Rack		∞	∞	.0375	.92	.09	.92	.09	

Differences of radii for each involute tooth,—face, .07; flank, .045.



# INDEX.

---

	PAGE		PAGE
Addendum, . . . . .	71, 75, 79, 99	Bolts, proportions for, . . . . .	21, 33
Admission of steam, . . . . .	50, 52, 59	“ round-head, . . . . .	34
Angle of action of gear-teeth, . . . . .	72, 74, 79	“ standard shape of thread of, . . . . .	21
“ “ advance of eccentric, . . . . .	38, 42, 50, 53, 56, 61	“ stud, . . . . .	32, 44, 46
“ “ obliquity of teeth, . . . . .	72, 79, 82, 90	“ tap, . . . . .	32
“ “ tangent of helix, . . . . .	13, 15	“ through, . . . . .	32, 46
“ “ crank, . . . . .	52, 60	Brass details, . . . . .	43
Angularity of connecting-rod, . . . . .	60	Broken length to accommodate paper, . . . . .	36
“ “ eccentric-rod, . . . . .	63	Bushing, . . . . .	39, 43, 46
Approximate shapes for gear-teeth, . . . . .	77, 81, 89, 100	Caps for bearings, . . . . .	45
Arc of approach of teeth, . . . . .	73	Cast-iron, section lines for, . . . . .	19
“ recess of teeth, . . . . .	73	Clearance for gear-teeth, . . . . .	78
Arms of gear-wheels, . . . . .	85	“ of steam piston, . . . . .	45
Base-circle of gear-wheels, . . . . .	70	“ space in steam cylinder, . . . . .	50
Base-lines, . . . . .	10, 57	Compression of steam, . . . . .	54, 59
Bevel gear-wheels, . . . . .	90	“ equalization of, . . . . .	61
Bilgram valve diagram, . . . . .	55	Connecting-rod, . . . . .	36, 43
Black forgings, . . . . .	33	“ adjustable, . . . . .	65
Blue Prints, . . . . .	10	“ angularity of, . . . . .	60
Bolts, . . . . .	20, 32	Construction drawing, . . . . .	27, 48
“ black, . . . . .	33	Counterbalancing reciprocating parts, . . . . .	38, 40
“ conventional drawing of, . . . . .	24	Covers for cylinder and steam-chest, . . . . .	44
“ list of, . . . . .	34	Crank-angle, . . . . .	52, 60

	PAGE		PAGE
Crank-shaft, . . . . .	37	Engine, crosshead for, . . . . .	41
Crosshead, . . . . .	41	“ cylinder for, . . . . .	45
Cut-off, . . . . .	53, 59	“ eccentric and strap for, . . . . .	42
“ equalization of, . . . . .	60	“ eccentric-rod for, . . . . .	36, 65
Cycloid, . . . . .	87	“ fly-wheel for, . . . . .	40
Cycloidal gear-teeth, . . . . .	86	“ frame for, . . . . .	47
Cylinder, . . . . .	45	“ gland, bushing and brasses for, . . . . .	39, 43
“ head, . . . . .	44	“ list of bolts for, . . . . .	29, 34
Decimal equivalents, . . . . .	76, 96	“ “ pieces for, . . . . .	28
Designing of valve motion, . . . . .	62	“ piston for, . . . . .	39
Details, names of, . . . . .	27	“ piston-rod and pins for, . . . . .	35
“ numbers for, . . . . .	28, 29	“ piston-rings for, . . . . .	35
“ scale of, . . . . .	30	“ slide-valve for, . . . . .	41
Development of helix, . . . . .	12	“ valve motion of, . . . . .	51, 55
“ “ tangent cones of bevel gears, . . . . .	92	Epicycloid, . . . . .	87
Diagram, valve, . . . . .	55	Equalization of cut-off, . . . . .	60
Diameter of wheels, pitch, . . . . .	75, 84, 91	“ “ exhaust, . . . . .	61
“ “ outside, . . . . .	75, 84	“ “ lead, . . . . .	60
“ “ root, . . . . .	75, 84	“ “ release and compression, . . . . .	61
Diametral pitch, . . . . .	83	Exhaust lap, . . . . .	52, 62
Directrix, . . . . .	14	Expansion of steam, . . . . .	54, 60
Dowel-pins, . . . . .	32, 45	Face of gear-teeth, . . . . .	71
Eccentric, . . . . .	42, 52, 56	“ “ width of, . . . . .	85, 92
“ angular advance of, . . . . .	38, 42, 50, 53, 56, 61	Fillet, . . . . .	37, 78, 100
“ throw, . . . . .	42, 59	Fixed point of Bilgram valve diagram, . . . . .	57
Engine, Bilgram valve diagram for, . . . . .	55	Finished forgings, . . . . .	33
“ bolts and keys for, . . . . .	32	Flank of gear-teeth, . . . . .	71, 77
“ brass details of, . . . . .	43	Fly-wheel, . . . . .	40
“ connecting-rod for, . . . . .	36, 43, 65	Gear-teeth, addendum of, . . . . .	71, 75
“ construction drawing of, . . . . .	27, 48	“ clearance for, . . . . .	78
“ covers and caps for, . . . . .	45	“ depth of, . . . . .	75, 99
“ crank-shaft for, . . . . .	37	“ diametral pitch of, . . . . .	83

	PAGE		PAGE
Gear-teeth, efficiency of, . . . . .	74, 80, 93	Gear-wheels, spur, pitch diameters of, . . . .	75, 84
“ errors liable to occur in cutting, . .	80	“ “ outside diameters of, . . . .	75, 84
“ face of, . . . . .	71, 77	“ “ root diameters of, . . . .	75, 84
“ fillets for, . . . . .	78, 100	“ proportions for, . . . . .	85
“ flank of, . . . . .	71, 77, 93	Generatrix, . . . . .	14, 17
“ for rack, . . . . .	76, 79	Gland, . . . . .	39, 43, 46
“ intervals of cutters for, . . . . .	82, 100	Globe valve, . . . . .	66
“ pitch of, . . . . .	70, 75	Helicoid, . . . . .	14
“ pitch point of, . . . . .	70, 77	Helix, . . . . .	11
“ width of face of, . . . . .	85, 92	“ pitch of, . . . . .	11, 15
“ cycloidal, . . . . .	86	“ angle of, . . . . .	13
“ “ approximate, . . . . .	89, 94, 100	“ development of, . . . . .	12
“ “ for bevel wheels, . . . . .	91	High face for fly-wheels, . . . . .	40
“ “ path of contact of, . . . . .	89	Hypocycloid, . . . . .	87
“ “ rolling circle for, . . . . .	87	Individual pitch of screws, . . . . .	16
“ “ to describe, . . . . .	88	Inking, . . . . .	10, 30
“ involute, . . . . .	70, 75, 77	Inside lap, . . . . .	52, 62
“ “ approximate, . . . . .	77, 81, 100	Intervals of cutters for teeth, . . . . .	82, 100
“ “ base circle for, . . . . .	70	Interchangeable gear wheels, . . . . .	81, 88
“ “ interchangeable, . . . . .	81	Involute, . . . . .	69, 77
“ “ line of action of, . . . . .	70, 76	“ point of origin of, . . . . .	77
“ “ locus of centres for arcs of, . . . . .	83	“ by approximate circular arcs, . . . .	77, 100
“ “ obliquity of action of, . . . . .	74	“ teeth for gear wheels, . . . . .	69, 75
“ “ path of contact of, . . . . .	70, 72, 79	Joint, rubber, . . . . .	44
“ “ reasons for superiority of, . . . . .	80, 90	Keys, . . . . .	32, 65
“ “ to describe, . . . . .	77	Key-seats, . . . . .	38, 41, 42
Gear-wheels, bevel, . . . . .	90	Lead of slide-valve, . . . . .	50, 52, 60
“ developed arcs of, . . . . .	92	Lap, exhaust, . . . . .	52, 62
“ “ pitch circles of, . . . . .	91	“ inside, . . . . .	52, 62
“ “ pitch diameters of, . . . . .	91	“ negative, . . . . .	52
“ “ tangent cones of, . . . . .	92	“ outside, . . . . .	51
“ spur, . . . . .	67	“ steam, . . . . .	51, 61

	PAGE		PAGE
Lap, circle, . . . . .	56, 59	Pitch of screw threads, . . . . .	11, 15, 16, 21
Left-hand screw threads, . . . . .	19	“ point, . . . . .	70, 77, 91
Lines, rules for inking, . . . . .	10, 30	Port, exhaust, . . . . .	46, 53
Line of centres of gear wheels, . . . . .	68	“ opening, . . . . .	56, 59, 62
“ action of teeth, . . . . .	70, 76, 79, 93	“ steam, . . . . .	46
Motion, valve, . . . . .	51, 55	Proportions for bolts, . . . . .	21
Multiple threads, . . . . .	16	“ “ gear wheels, . . . . .	85
Names for details, . . . . .	27	“ “ pipes, . . . . .	25, 98
Negative lap, . . . . .	52	“ “ square threads, . . . . .	16, 18, 20
Numbers for details, . . . . .	28, 29	Rack, teeth of, . . . . .	76, 79
Number of teeth in wheels, smallest, . . . . .	72, 74, 79, 88	Ratio, velocity, . . . . .	68
Nut for screw-thread, . . . . .	15	Release of steam, . . . . .	59
Nuts for bolts, . . . . .	21, 23, 33	Right-hand screw threads, . . . . .	19
Obliquity of action of gear teeth, . . . . .	74, 79, 82, 90, 93	Rim of gear wheels, thickness of, . . . . .	86
Oil holes, . . . . .	35, 36, 40, 42, 43	Rings for piston, . . . . .	35
“ cup, . . . . .	44	Rolling circle for cycloidal teeth, . . . . .	87
Paper, size of, . . . . .	10, 30, 49, 75	“ “ teeth of bevel wheels, . . . . .	91, 93
Path of contact, . . . . .	70, 72, 89, 93	Root diameter of gear wheels, . . . . .	75, 84
Pins for crosshead and valve stem, . . . . .	35	Scales, drawing, . . . . .	7, 9, 30, 49, 56
“ dowel, . . . . .	32, 45	Screws, efficiency of, . . . . .	15
“ split, . . . . .	35	Screw threads, conventional, . . . . .	18, 19, 24
Pipe threads, . . . . .	25	“ “ individual pitch of, . . . . .	16
Pipes, drain, . . . . .	46, 50	“ “ multiple, . . . . .	16
Piston, . . . . .	39	“ “ proportions of, . . . . .	16, 18, 20, 21, 97
“ rings, . . . . .	35, 39	“ “ right or left hand, . . . . .	19
“ rod, . . . . .	35	Section lines for brass, . . . . .	39
Pitch circle, . . . . .	70, 76	“ “ cast iron, . . . . .	19, 41
“ cone, . . . . .	90	“ “ wrought-iron and steel, . . . . .	19, 36
“ cylinder, . . . . .	70	Shop drawings, . . . . .	26
“ diameter, . . . . .	75, 84, 91	Slide-valve, . . . . .	41
“ diametral, . . . . .	83	Split pins, . . . . .	35
“ of gear teeth, . . . . .	70, 75	Steam chest, . . . . .	46

INDEX.

105

	PAGE		PAGE
Steam cylinder, . . . . .	45	Threads, bolt, . . . . .	21, 34
“ lap, . . . . .	51, 61	“ pipe, . . . . .	25
“ pipe, . . . . .	25, 46	“ screw, . . . . .	14, 16, 21
“ port, . . . . .	46, 53	Titles of drawings, . . . . .	30
Steel, . . . . .	19	Valve globe, . . . . .	66
Tangent of helix, . . . . .	13	“ rod, . . . . .	35
“ cones of bevel wheels, . . . . .	92	“ seat, . . . . .	46
Taper of arms, . . . . .	86	“ slide, . . . . .	41
“ fly-wheel face, . . . . .	40	“ motion, . . . . .	51, 55
“ hole, . . . . .	39	“ “ designing of, . . . . .	62
“ keys, . . . . .	65	Vertical engine, . . . . .	26 27
“ rods, . . . . .	35	Velocity ratio of gear wheels, . . . . .	68, 87, 97
Teeth of wheels, bevel, . . . . .	92	Washers, . . . . .	24
“ “ cycloidal, . . . . .	88	Working drawings, . . . . .	27
“ “ involute, . . . . .	70, 77		

# WILLIAMS, BROWN & EARLE,

N. E. Cor. TENTH & CHESTNUT STS., PHILADELPHIA,

IMPORTERS AND MANUFACTURERS OF

## Mathematical and Engineering Supplies

PHOTOGRAPHIC AND PROJECTION APPARATUS  
OF EVERY DESCRIPTION.

Special attention devoted to Draughting Outfits for Colleges and Technical Schools.

SOLE MANUFACTURERS OF

THE BERGNER DRAWING BOARD,

MARCY SCIOPTICON,

“LINAURA” BLUE PRINT LINEN

PUBLISHERS OF

THORNE'S COURSE IN MECHANICAL DRAWING.

THORNE'S MECHANICAL DRAWING STUDIES.

STEREOPTICONS AND EDUCATIONAL LANTERN SLIDES A SPECIALTY.

SEND FOR CATALOGUES.

PLATE 21





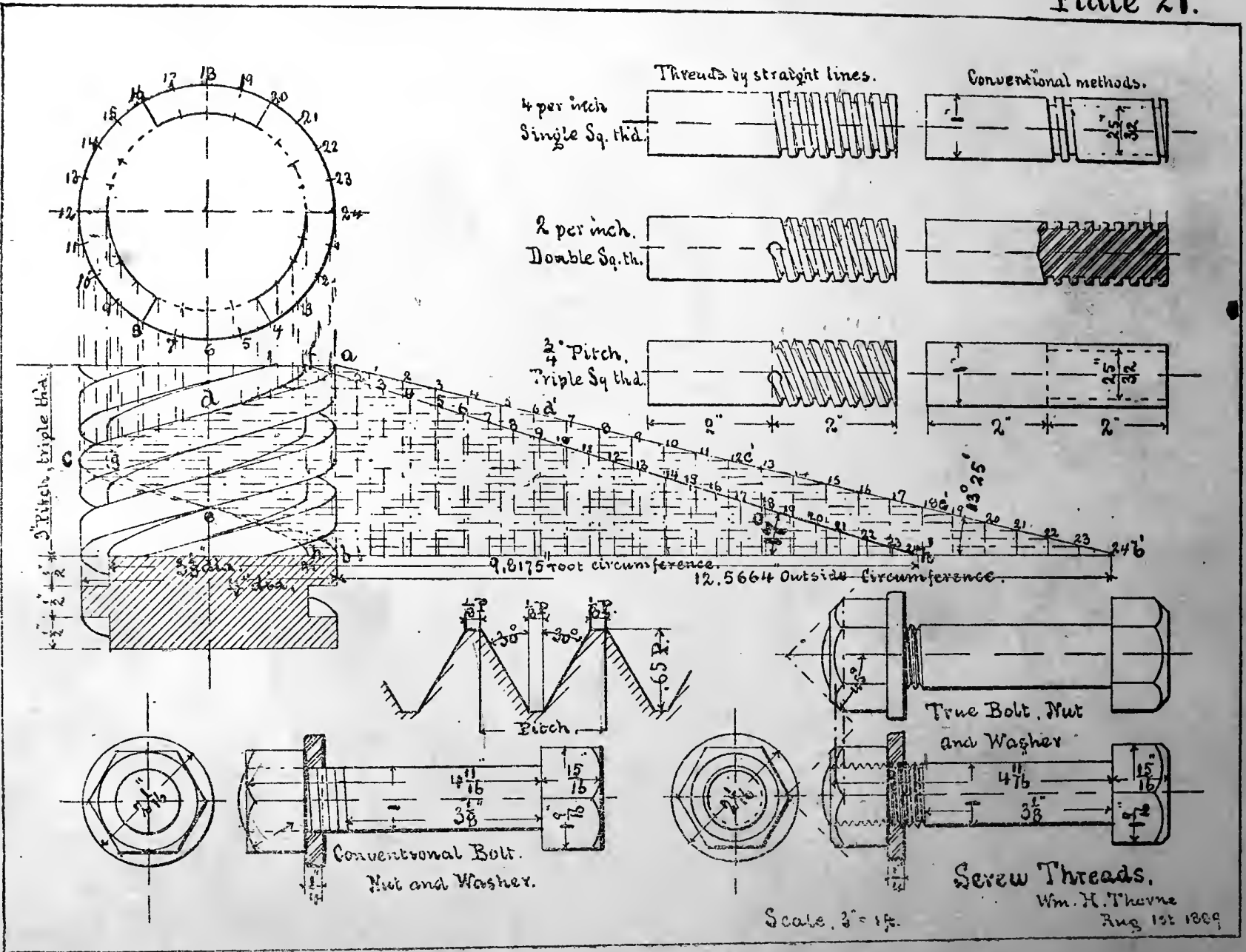
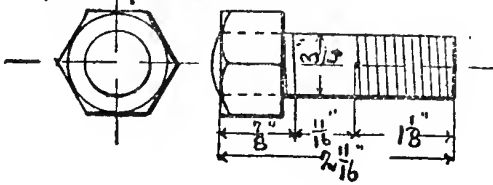



*PLATE 22*



4-No. 508, Stud Bolts.  
for Caps to Frame.



2-No. 510, Stud Bolts, Black.  
in Cylinder.

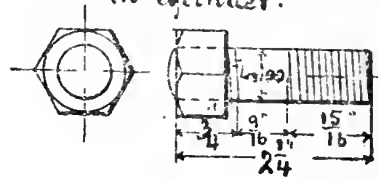

10-No. 509, Bolts, Black.  
in Cylinder.

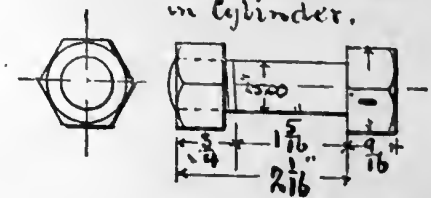

2-No. 511, Round Head Bolts.  
in Connecting Rod.

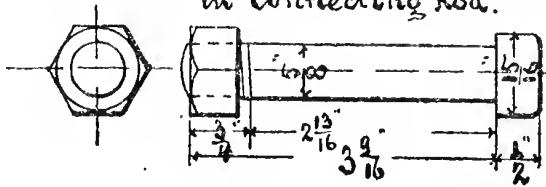

2-No. 513, Stud Bolts, Black.  
for Cylinder Gland.

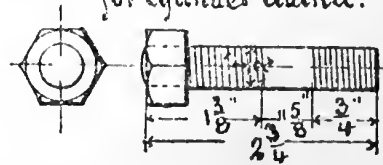

10-No. 512, Stud Bolts, Black.  
in Steam Chest.

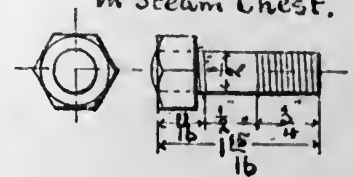

2-No. 514, Round Head Bolts.  
in Eccentric Straps.

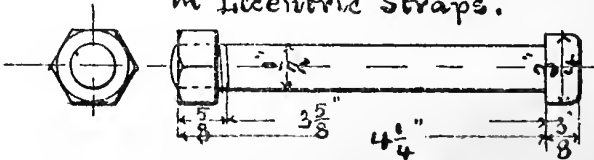

1-No. 516, Steel Key  
in Fly Wheel.

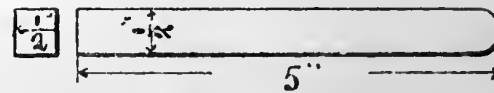

1-No. 515, Steel Key  
in Eccentric.

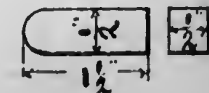

Scale. 3" = 1ft.

Forgings for 6" x 8" Vertical Engine,  
Wm. H. Thorne, Dec. 31st. 1884.



*PLATE 23*





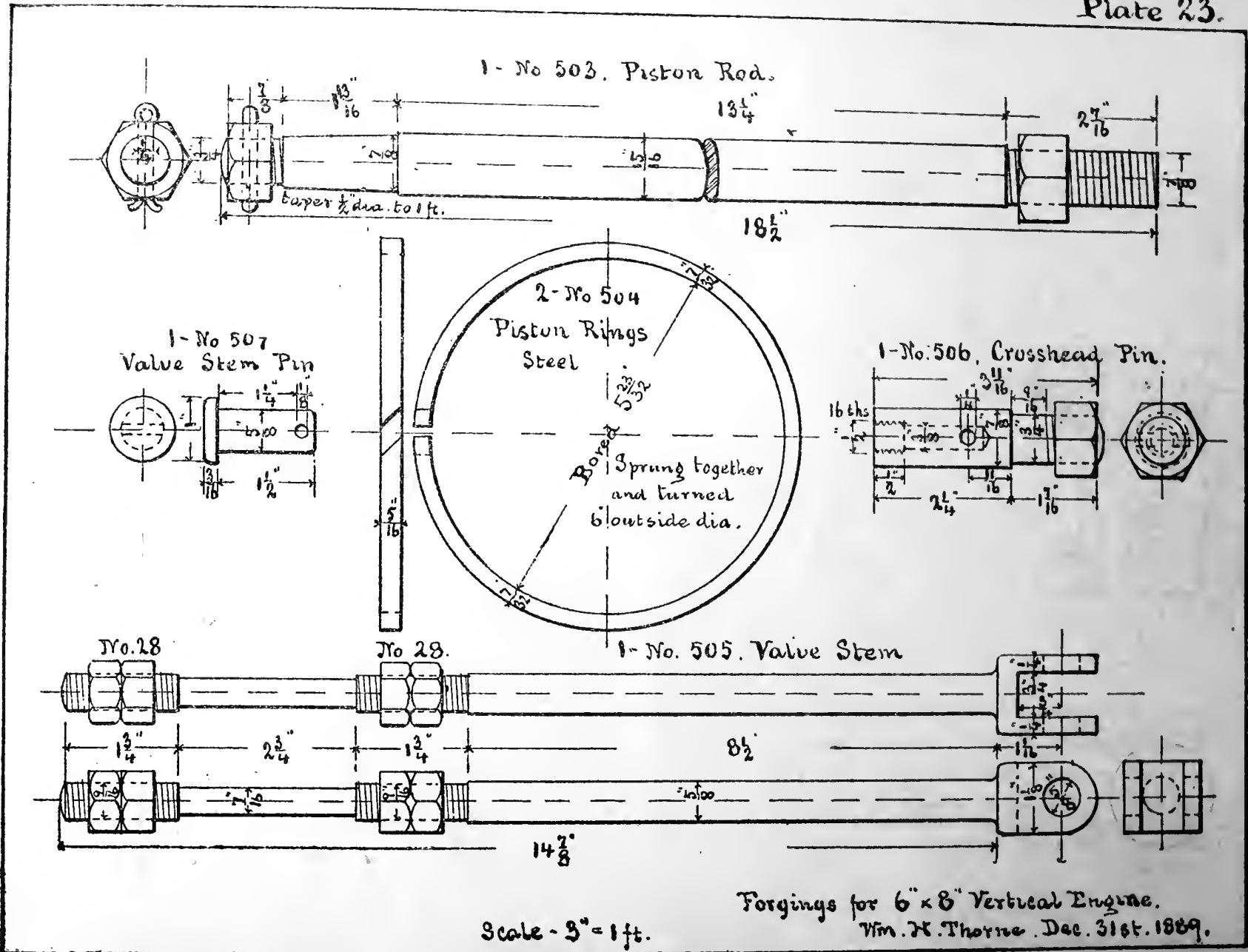

103 1-107 = C



*PLATE 24*



1-No 501, Connecting Rod.

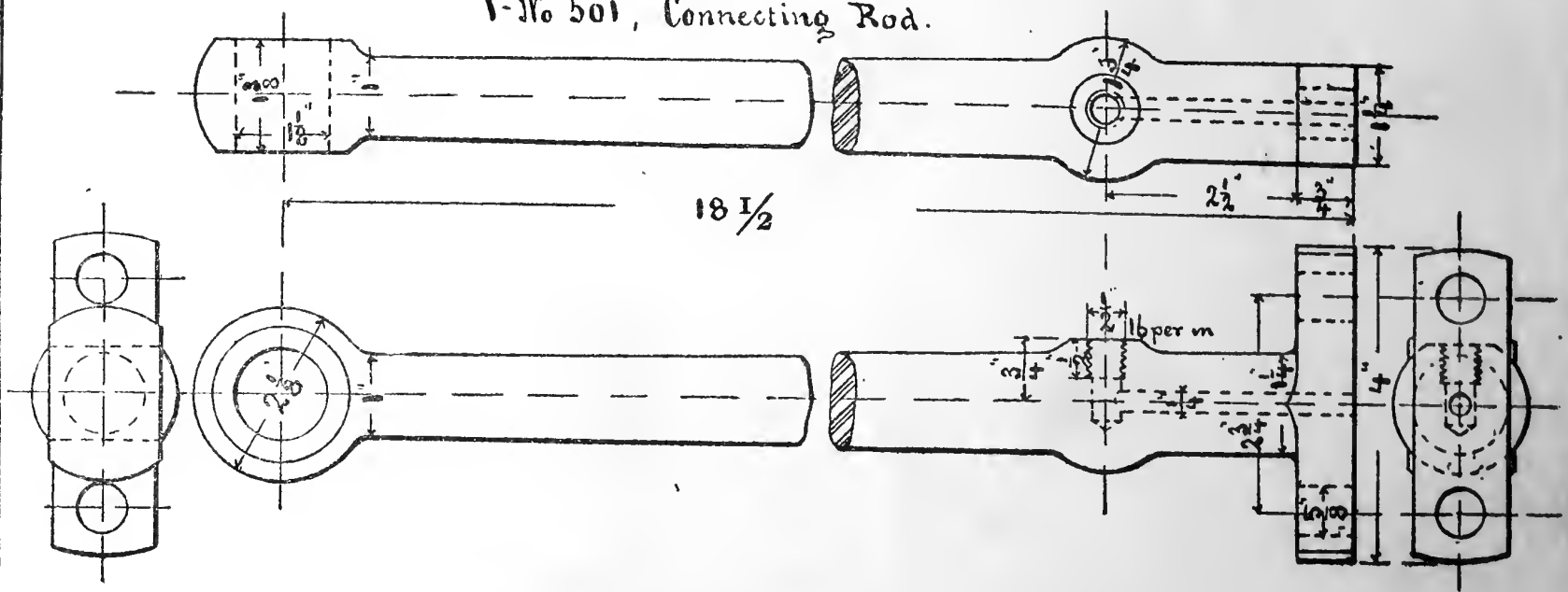

1- No. 502 Eccentric Rod.

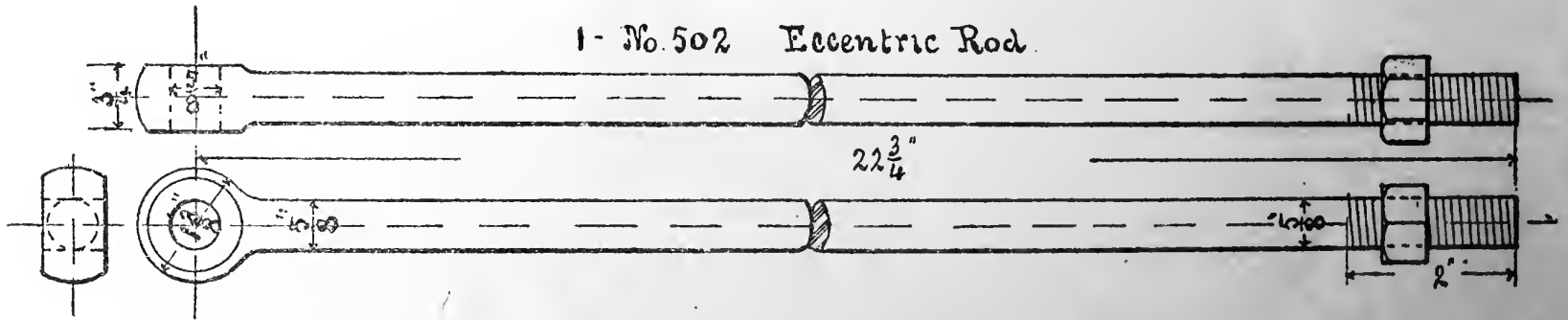

Forgings for 6 x 8 Vertical Engine.

Wm. H. Thorne, Dec. 31st. 1889.

Scale. 3" = 1ft

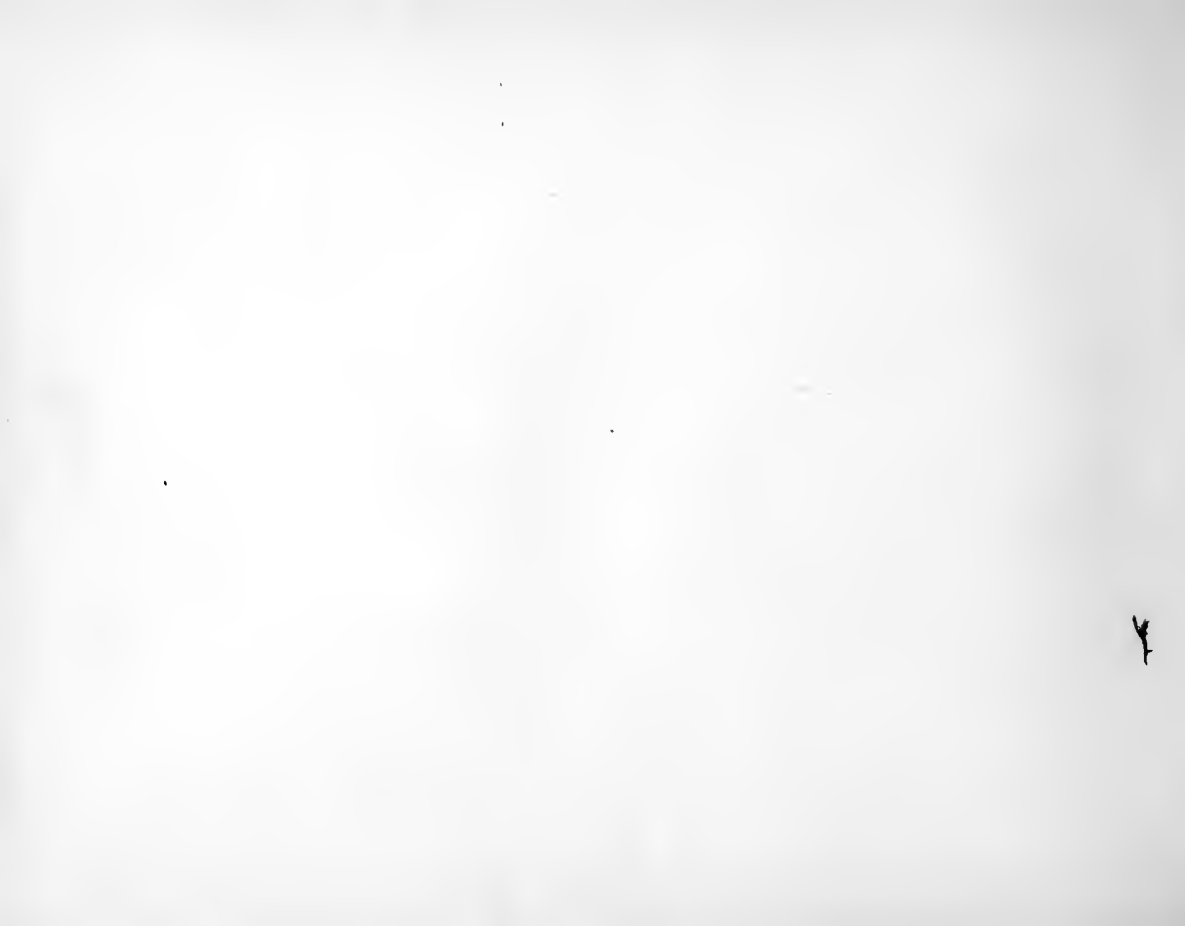

*PLATE 25*





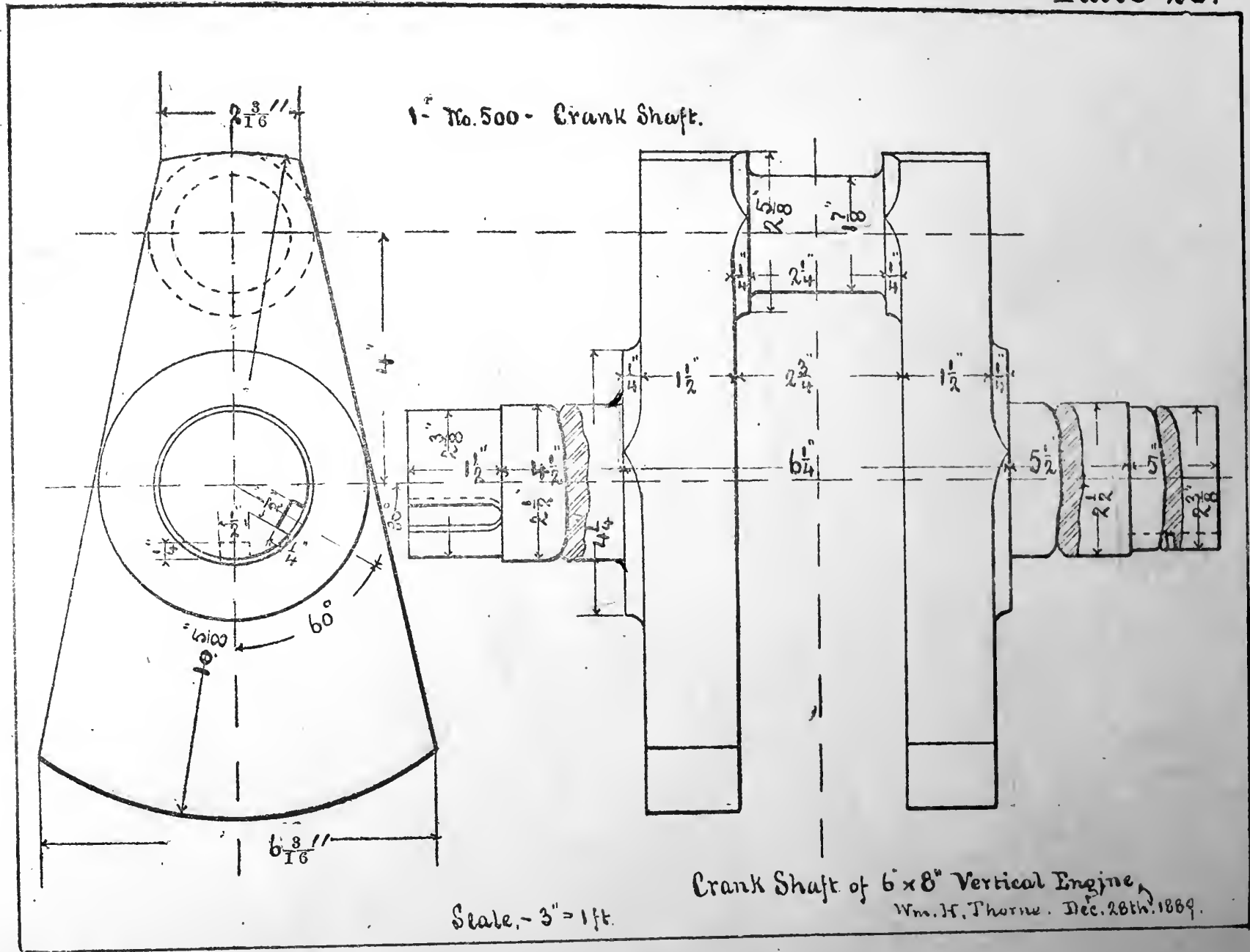
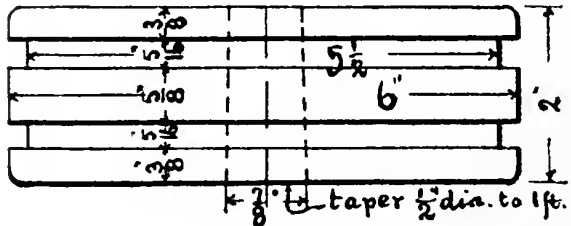
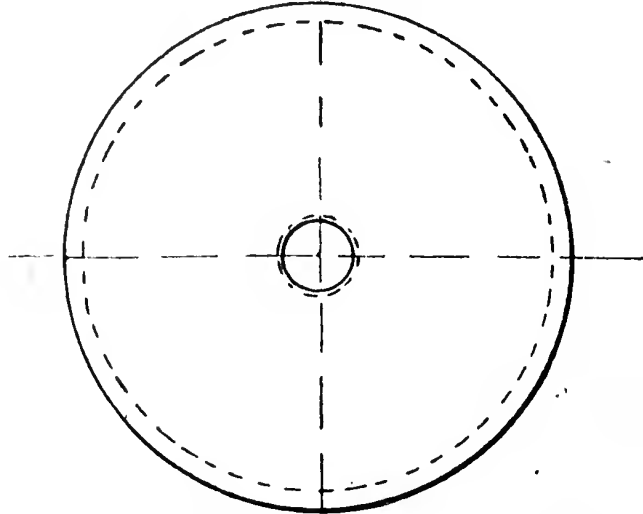



*PLATE 26*



1-#11 Piston.



1-#5, Brass Gland in Cylinder.

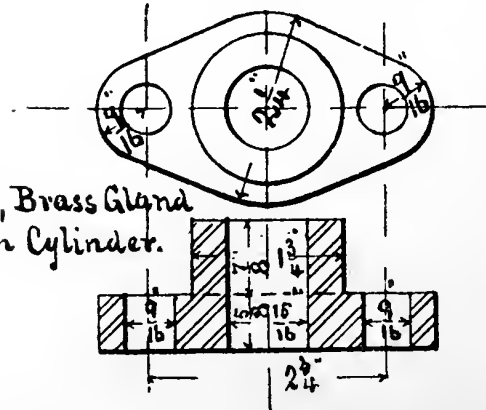

1-#6, Brass Bushing in Cylinder.

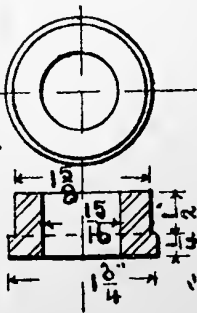

2-#15, Back Brass for Crank Shaft.

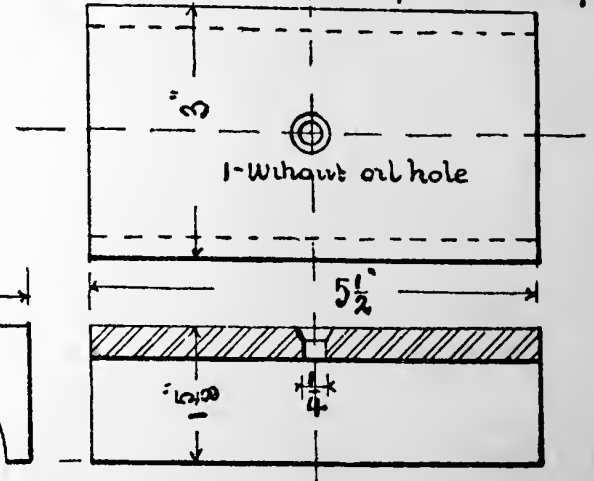

2-#14, Front Brass for Crank Shaft.

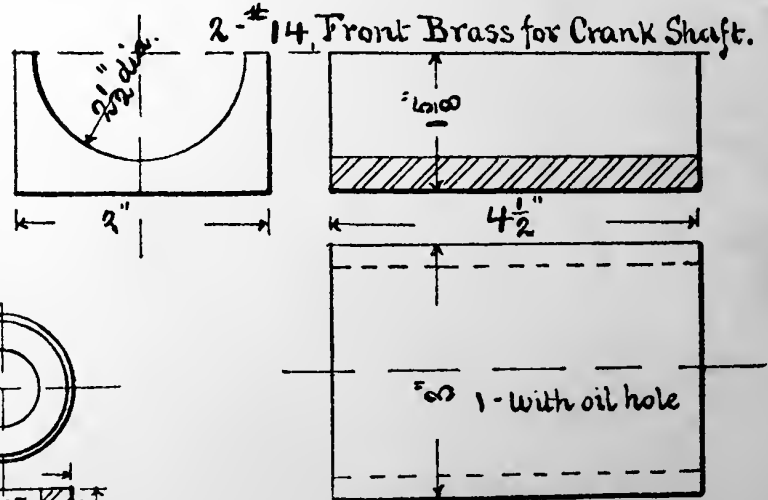

Details, - 6" x 8" Engine

Scale, 3" = 1ft.

Wm. H. Thorne, 10.28.89.

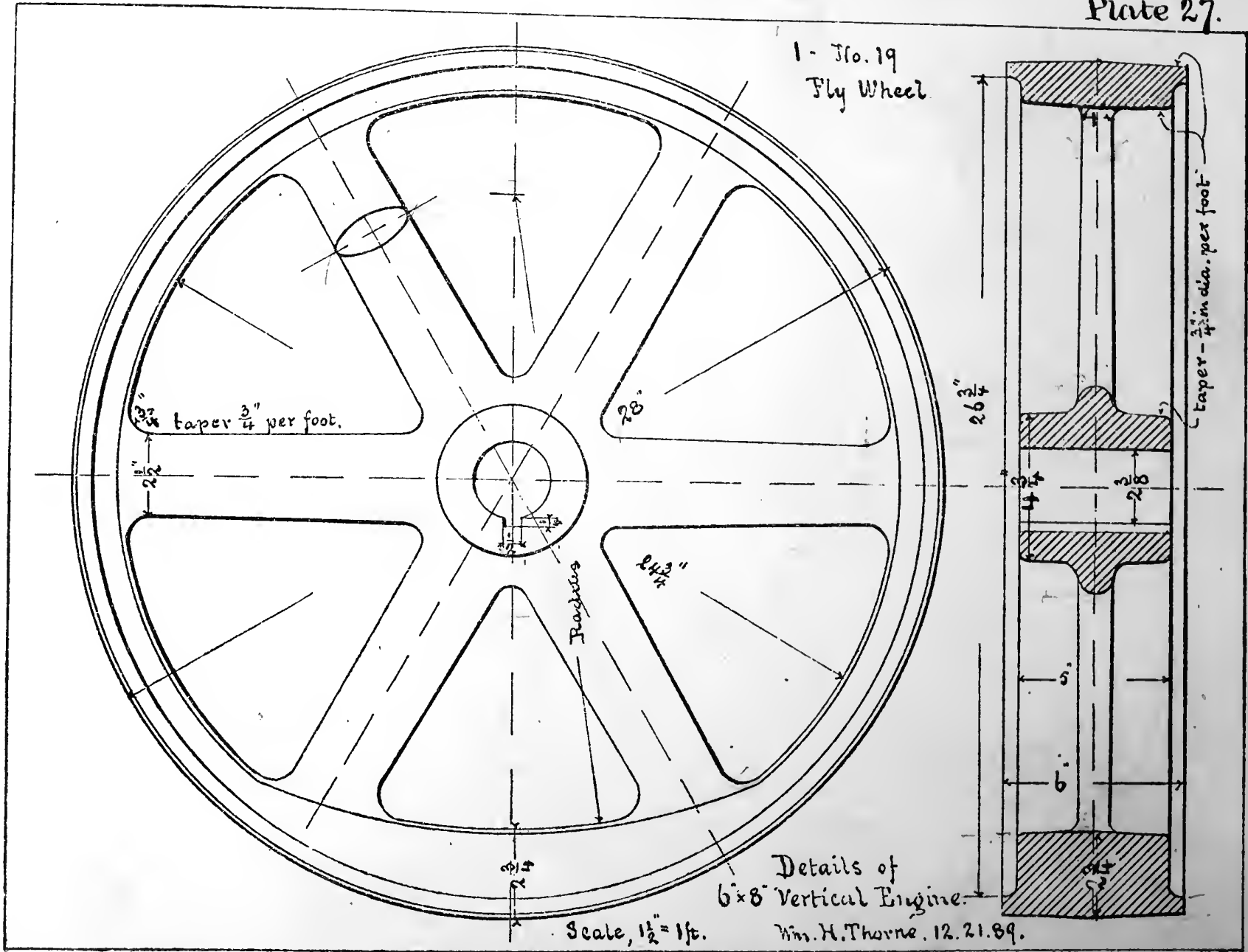

*PLATE 27*





1- No. 19  
Fly Wheel



$2\frac{3}{4}$ " taper  $\frac{3}{4}$ " per foot.

Spokes

$26\frac{3}{4}$ "

taper -  $\frac{3}{4}$ " in dia. per foot

Details of  
6x8 Vertical Engine.

Scale,  $1\frac{1}{2}$ " = 1ft.

Wm. H. Thorne. 12. 21. 89.



*PLATE 28*



1-No. 10. Slide Valve.

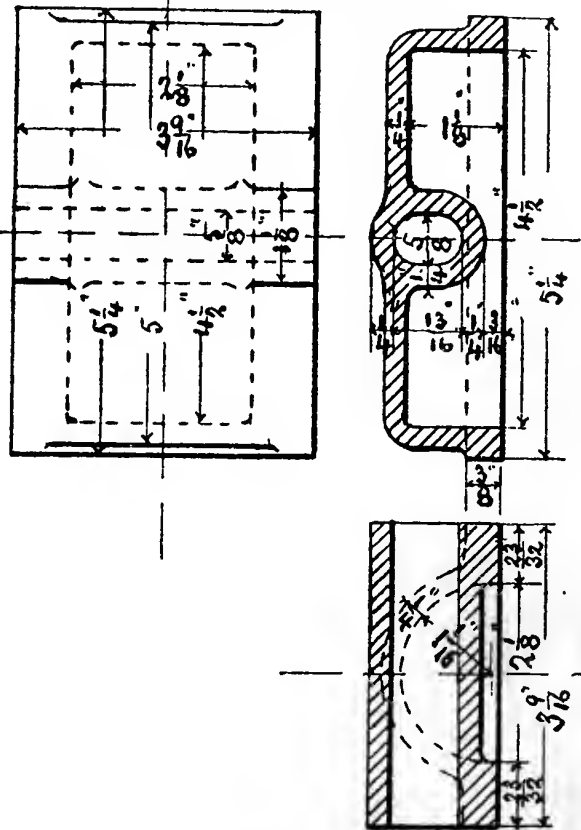

1-No. 20. Crosshead

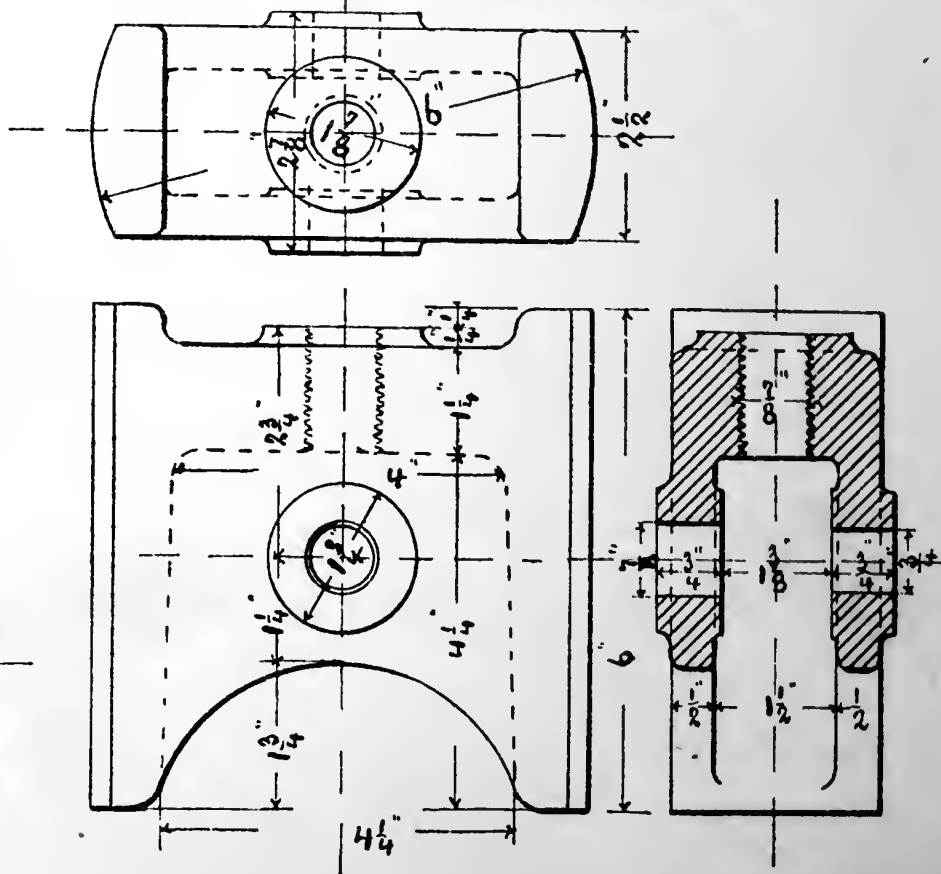

Scale, 3" = 1ft.

Details of 6x8" Vertical Engine.  
Wm. H. Thorne. Dec. 30th. 1889.

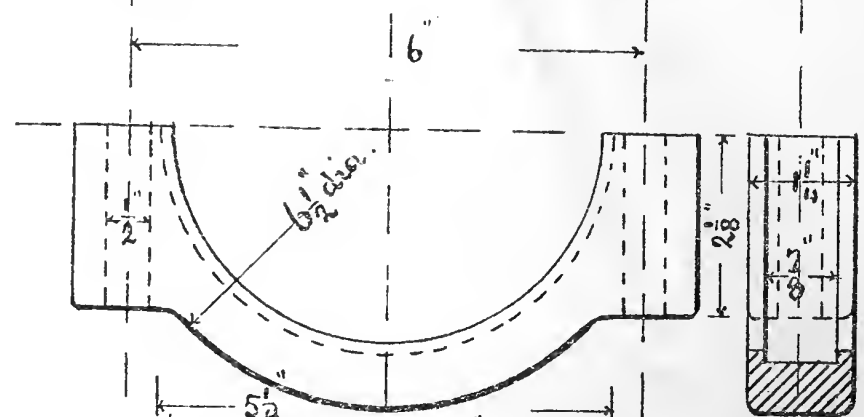
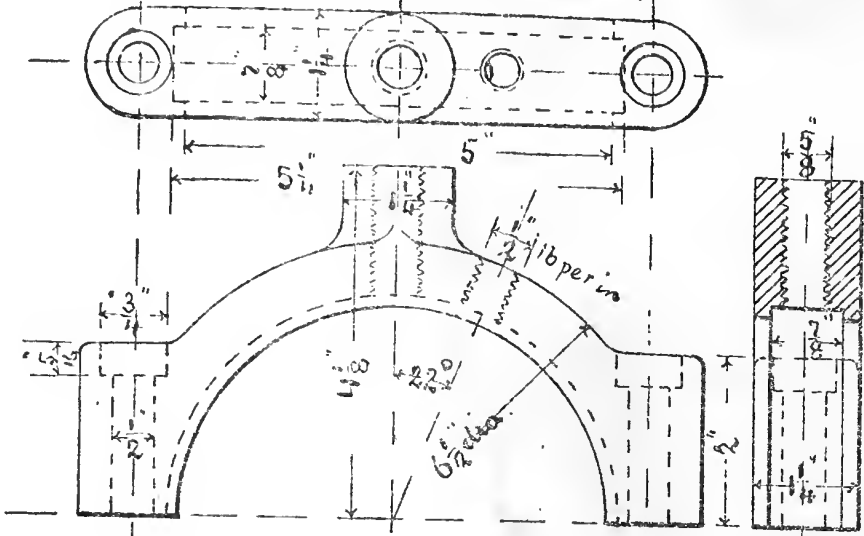

*PLATE 29*





1-No. 17, Top Half of Eccentric Strap.



1-No. 18, Bottom Half of Eccentric Strap.

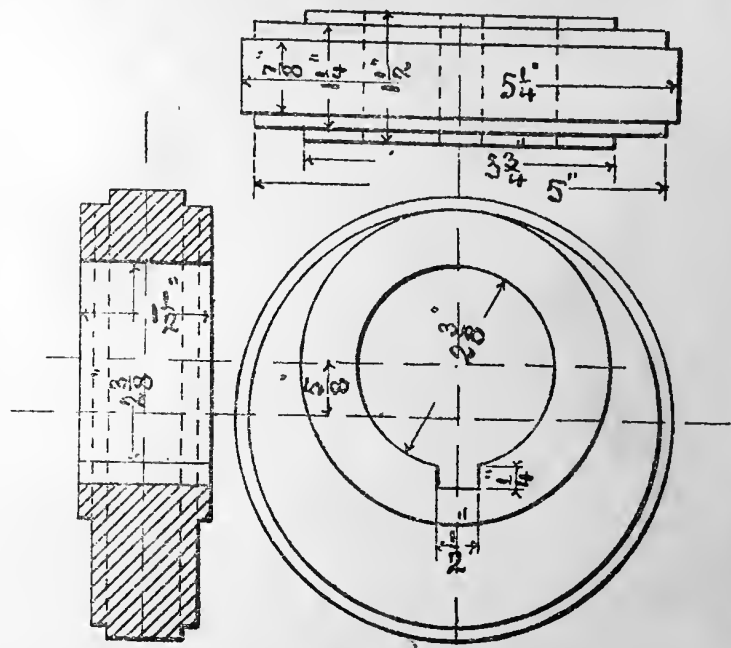
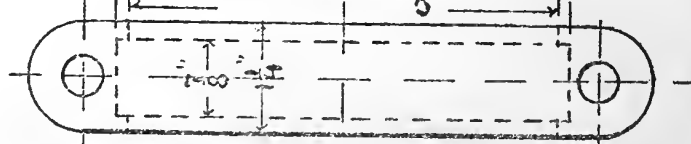

1-No. 16, Eccentric.

Details of 6" x 8" Vertical Engine.  
 Wm. H. Thorne, Dec. 30th. 1889.

1/4 size.



*PLATE 30*







*PLATE 31*



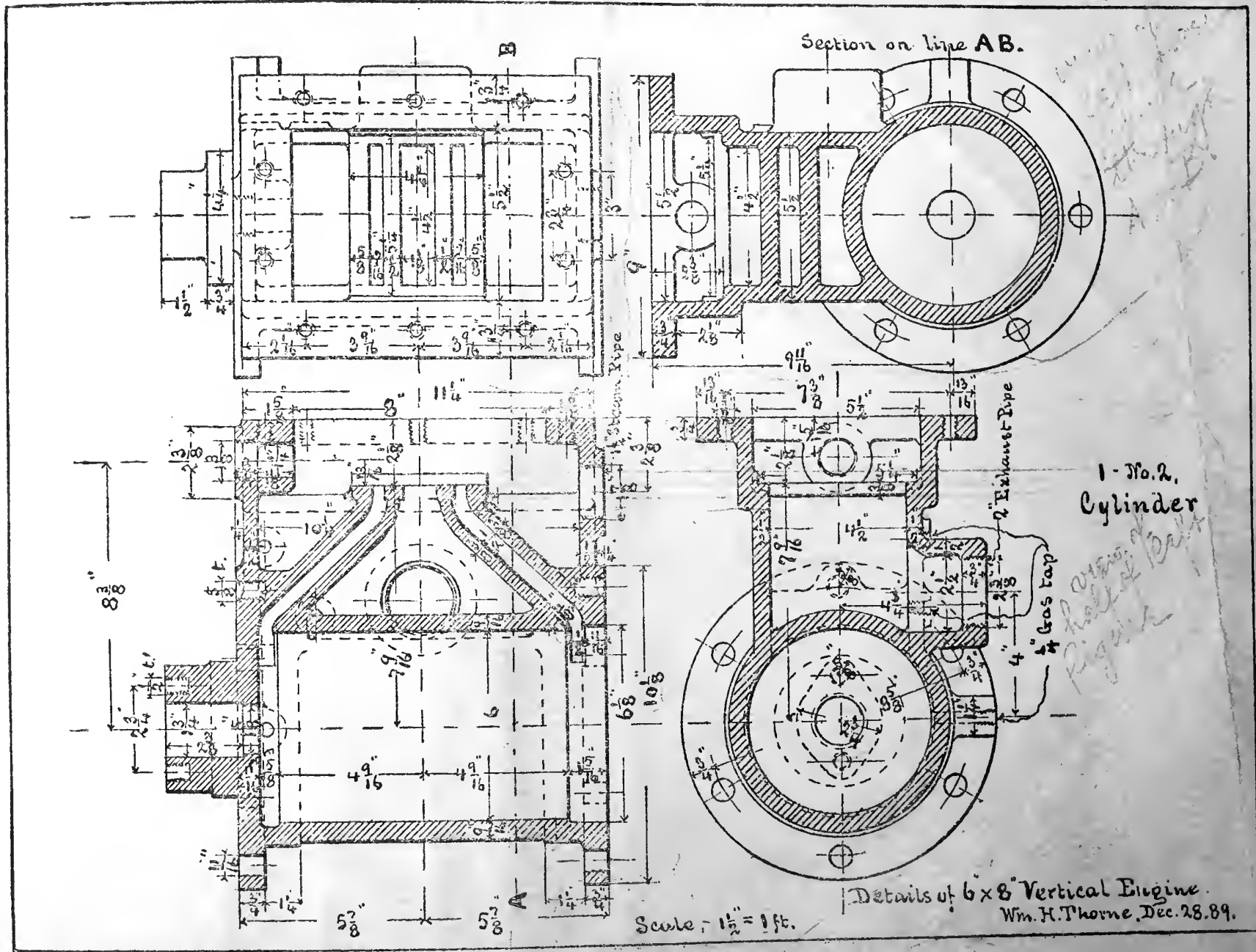





*PLATE 32*





Details of 6x8 Vertical Engine.  
 Wm. H. Thorne, Dec. 28. 89.

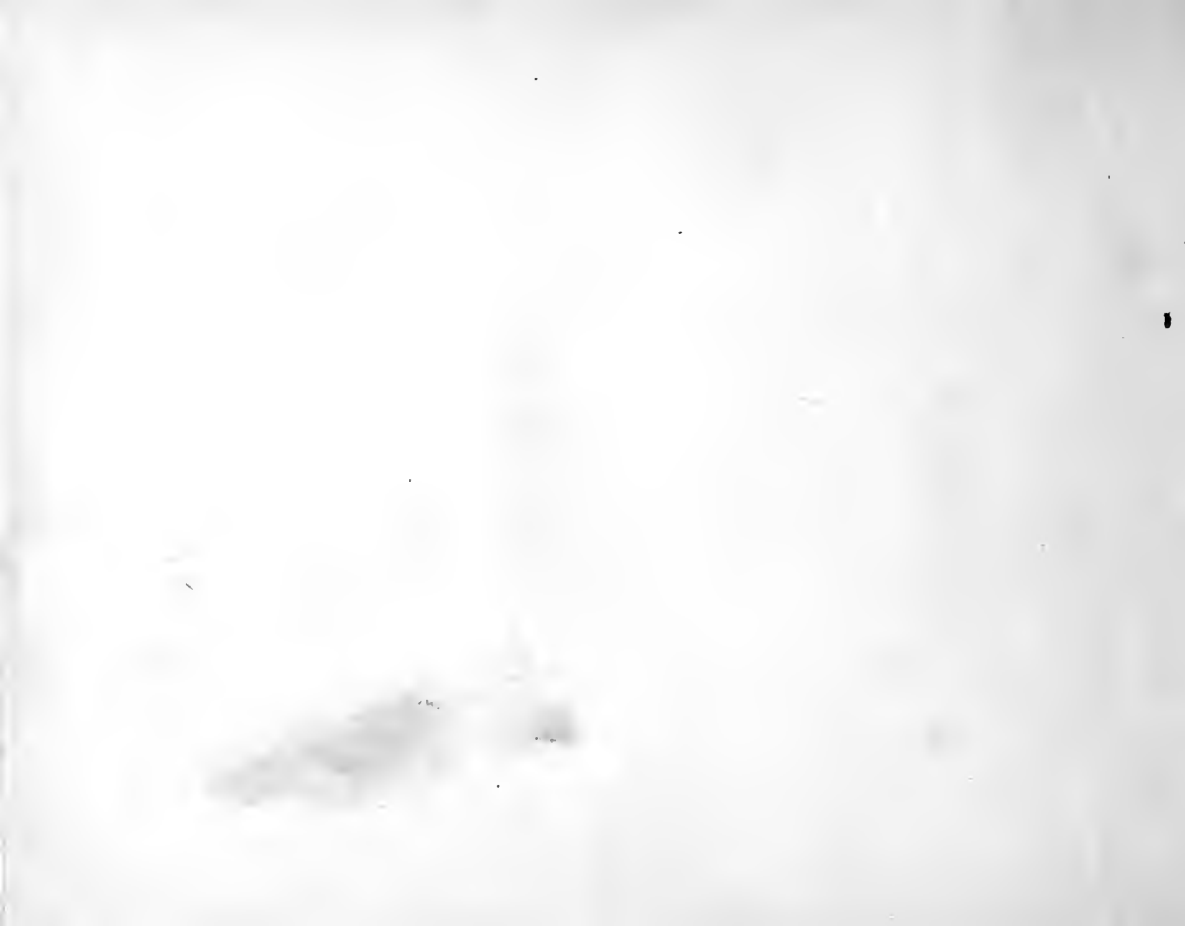
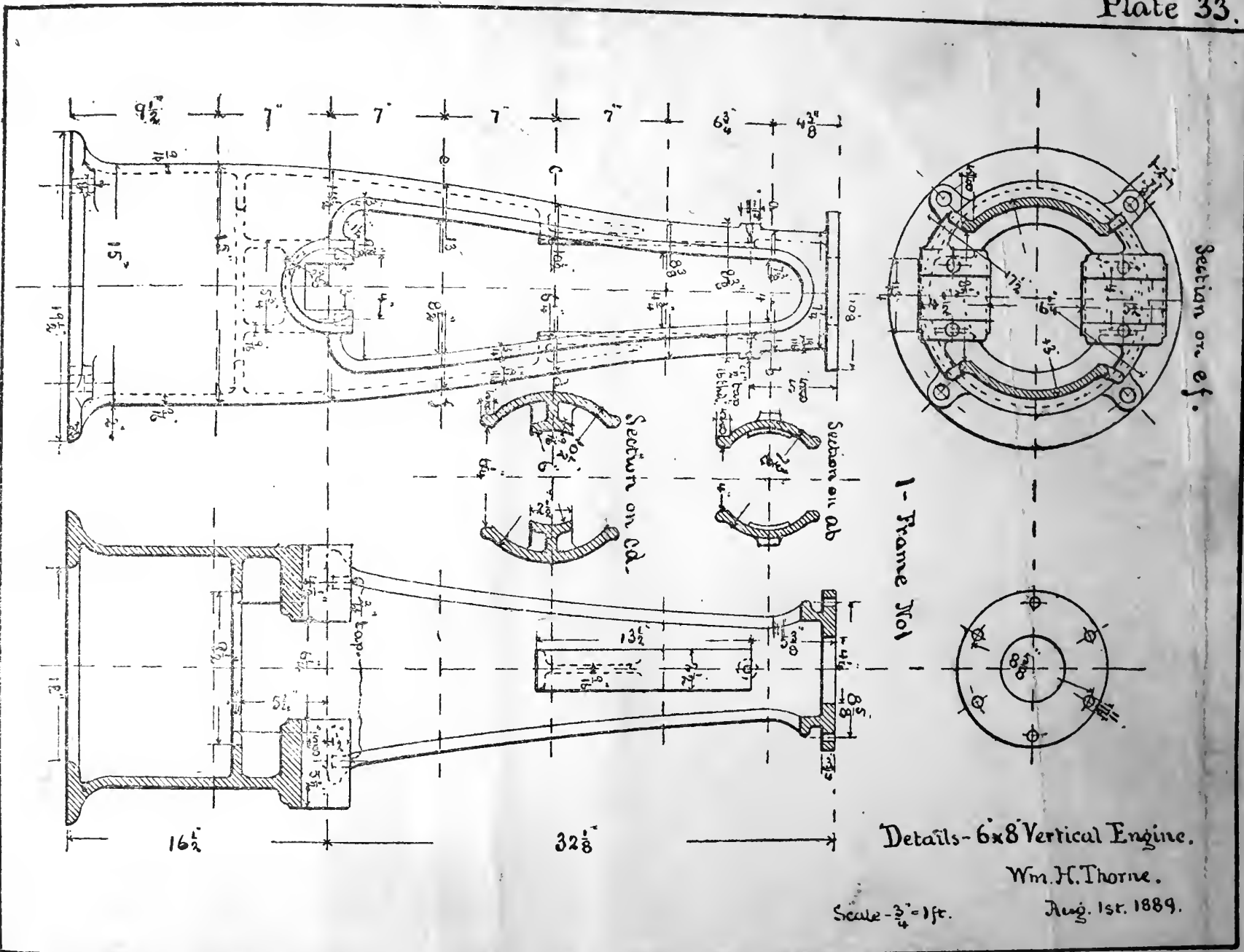

PLATE 33







Section on ef.

1-Frame Jol

Details-6x8 Vertical Engine.

Wm. H. Thorne.

Scale - 3/4" = 1ft.

Aug. 1st. 1889.



*PLATE 34*



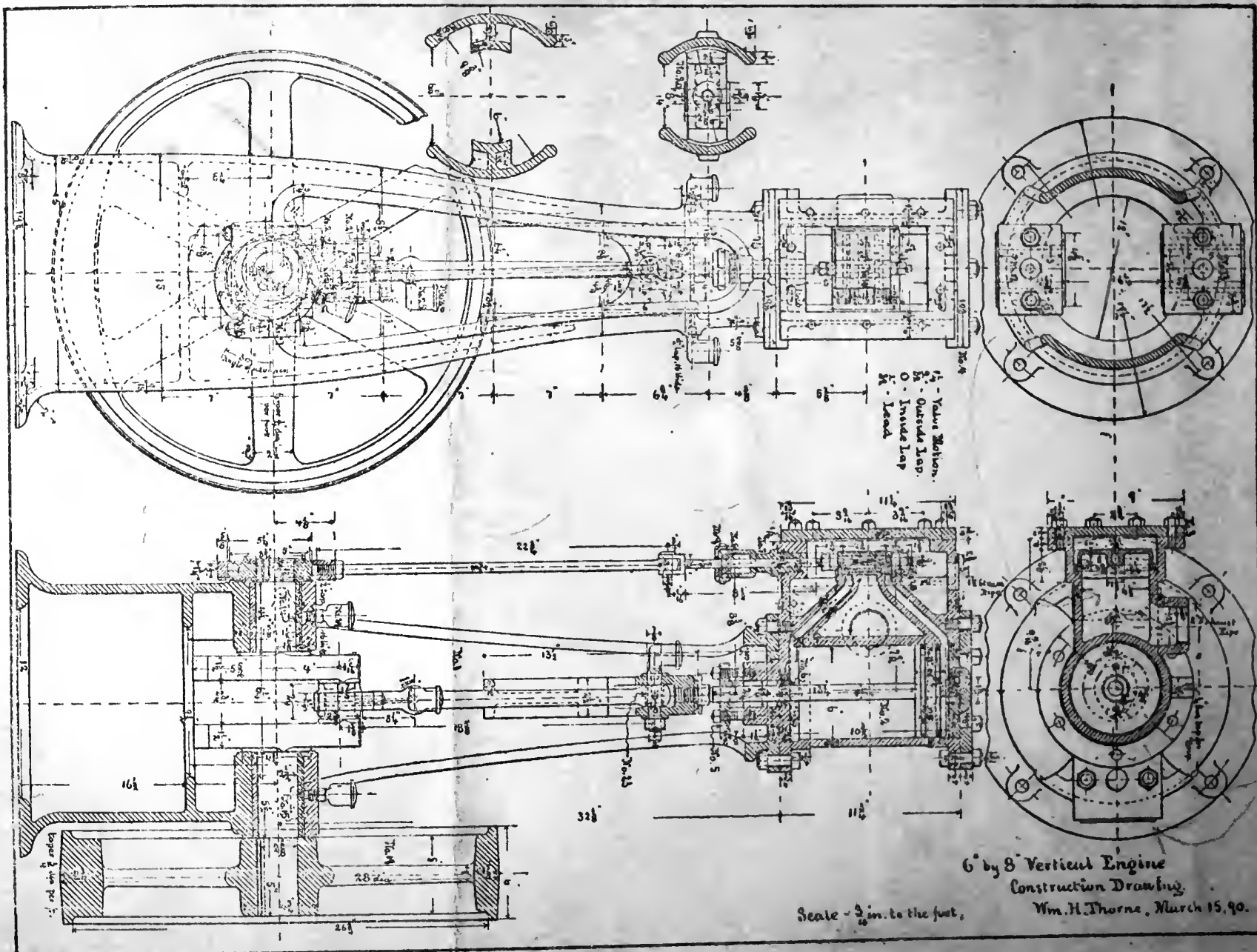

A - Valve Motion.  
 B - Outside Lap.  
 C - Inside Lap.  
 K - Lead.

6" by 8" Vertical Engine  
 Construction Drawing.  
 Wm. H. Thorne, March 15, 90.

Scale -  $\frac{3}{4}$  in. to the foot.



*PLATE 35*





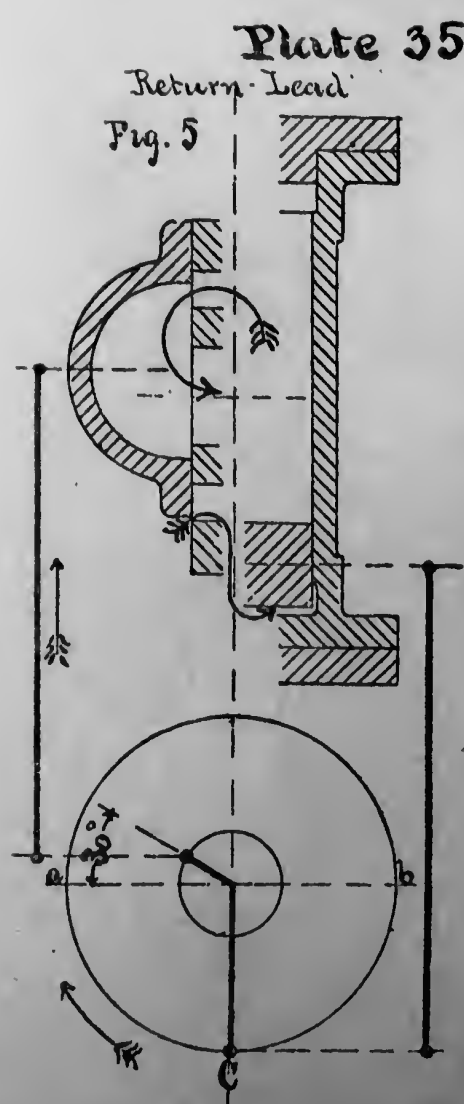
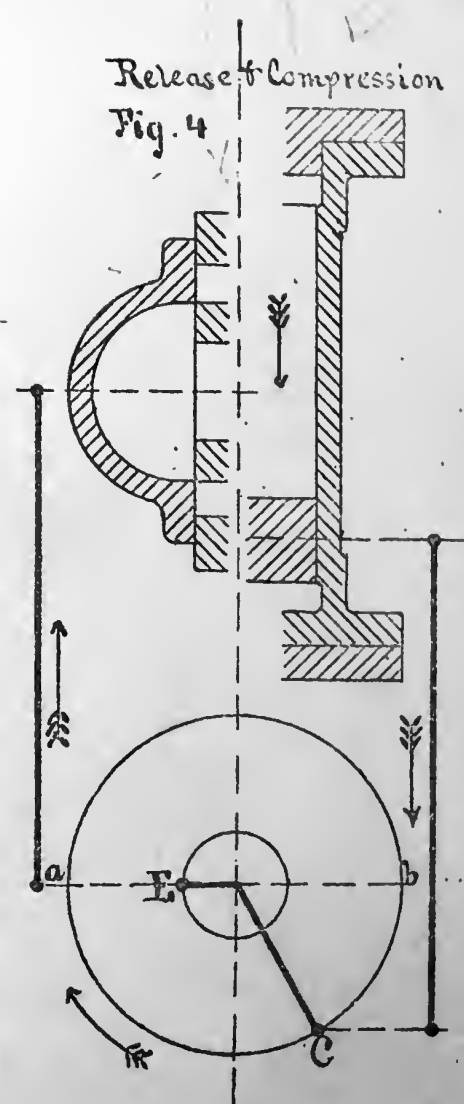
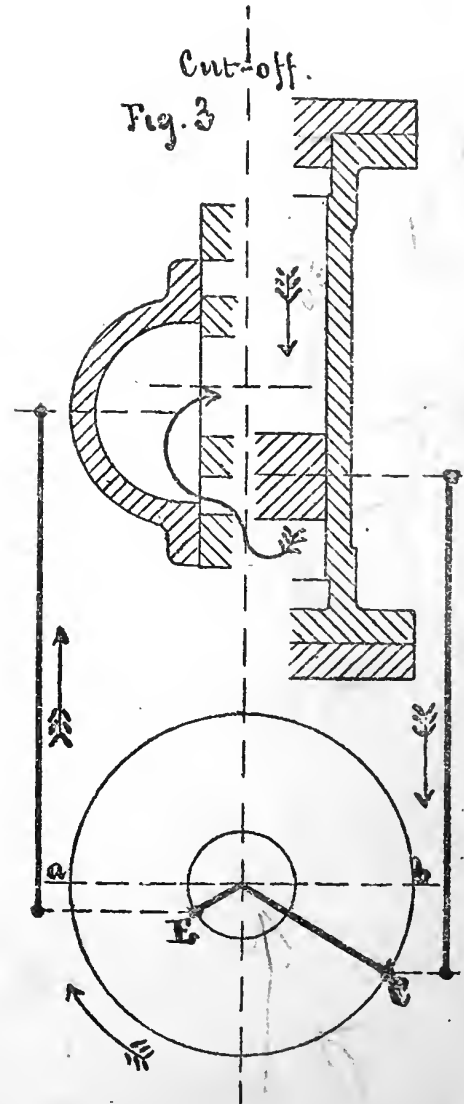
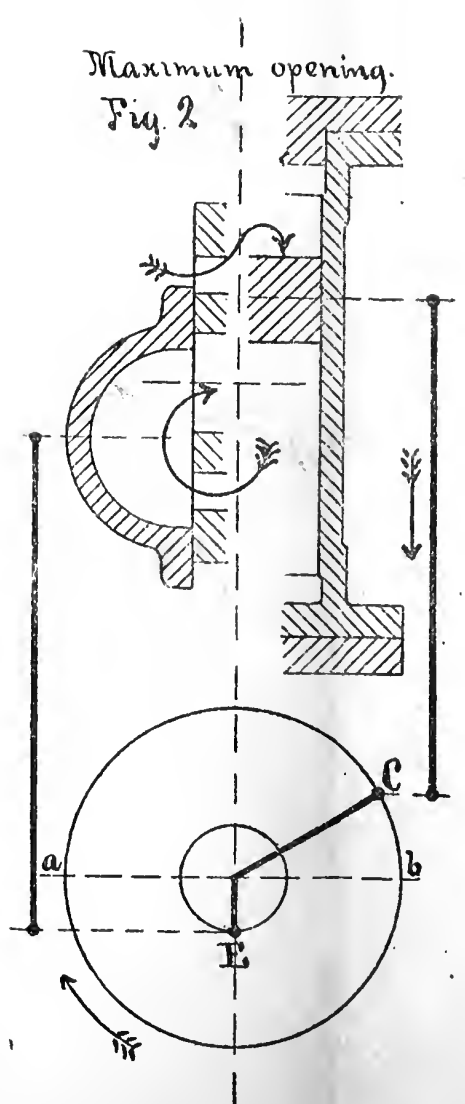
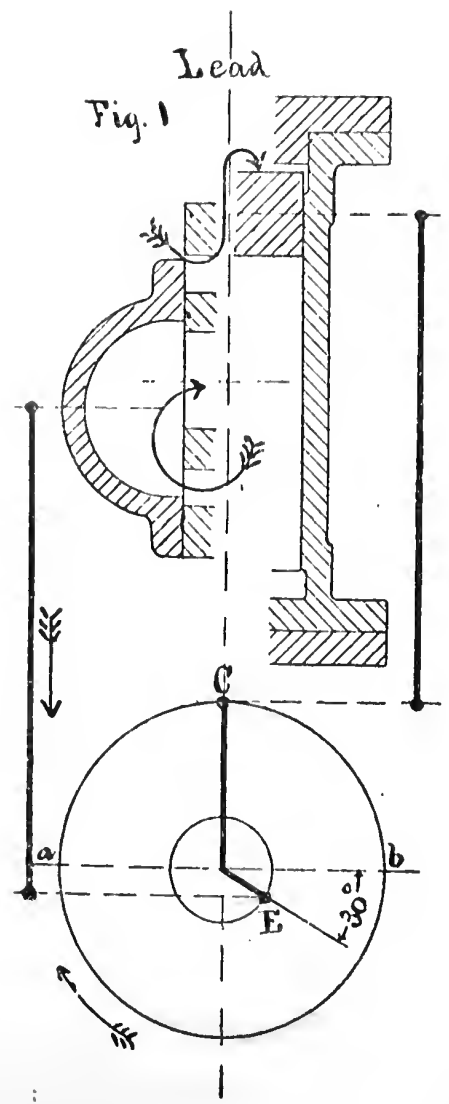

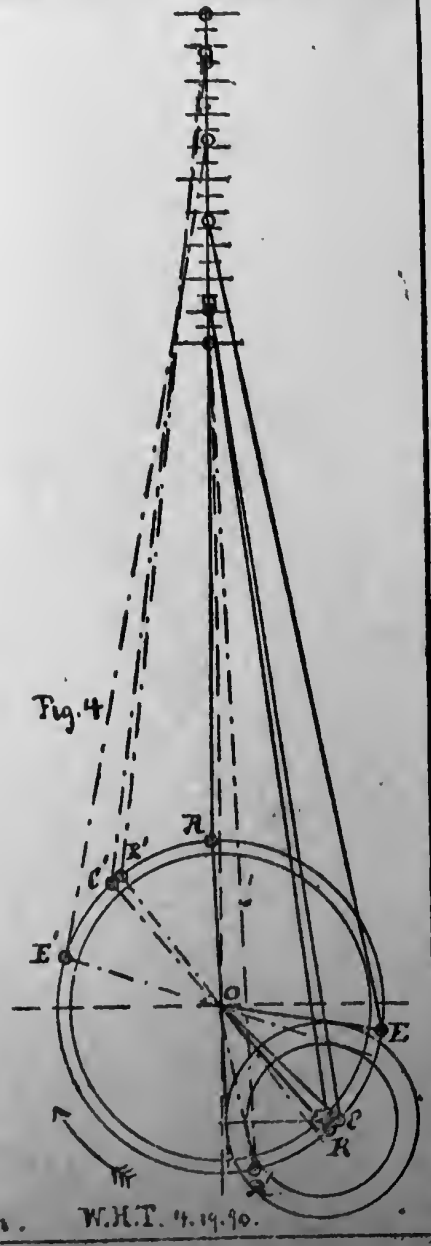
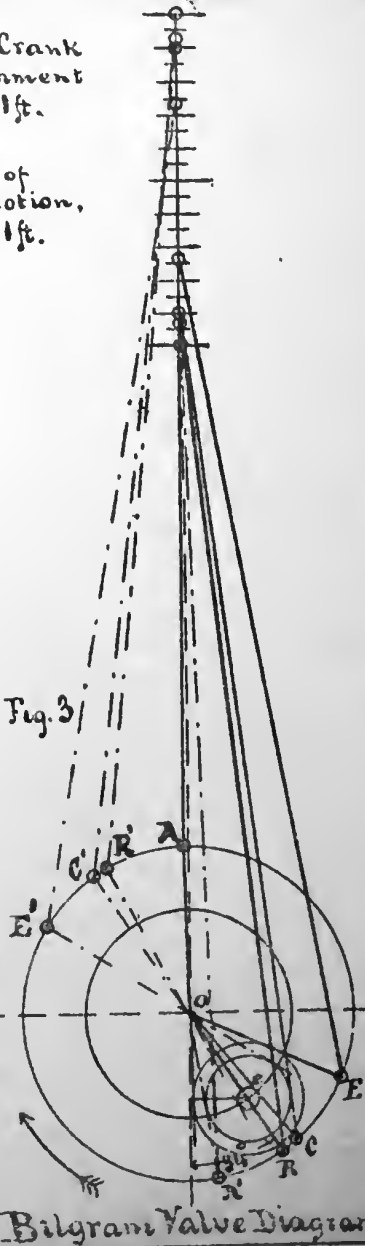
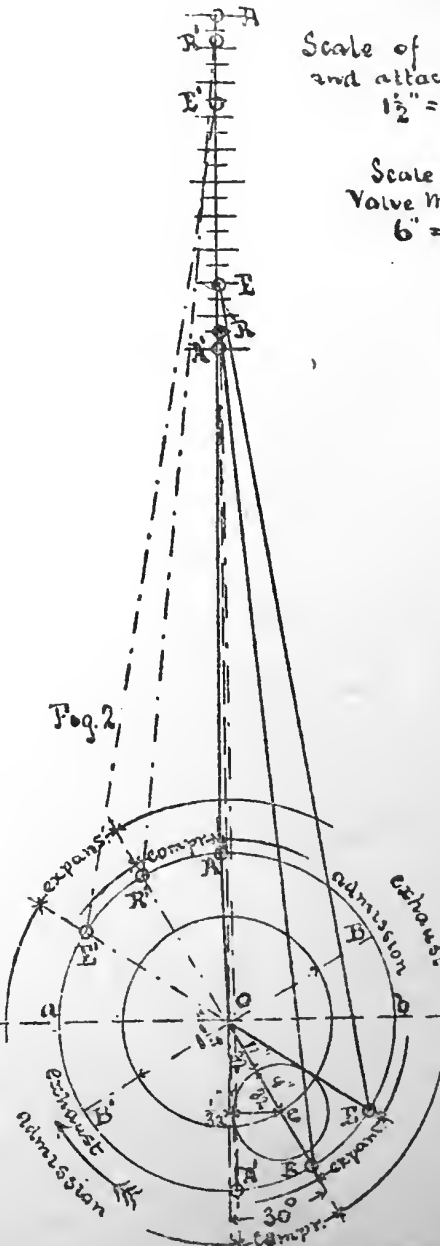
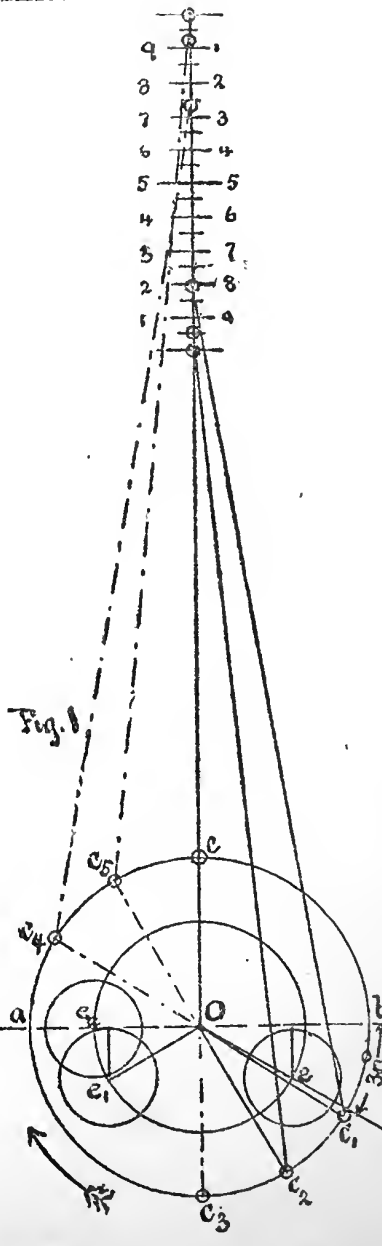

*PLATE 36*



Scale of Crank  
and attachment  
 $1\frac{1}{2}'' = 1\text{ft.}$

Scale of  
Valve Motion,  
 $6'' = 1\text{ft.}$



Bilgram Valve Diagram. W.H.T. 4.14.90.



*PLATE 37*









*PLATE 38*



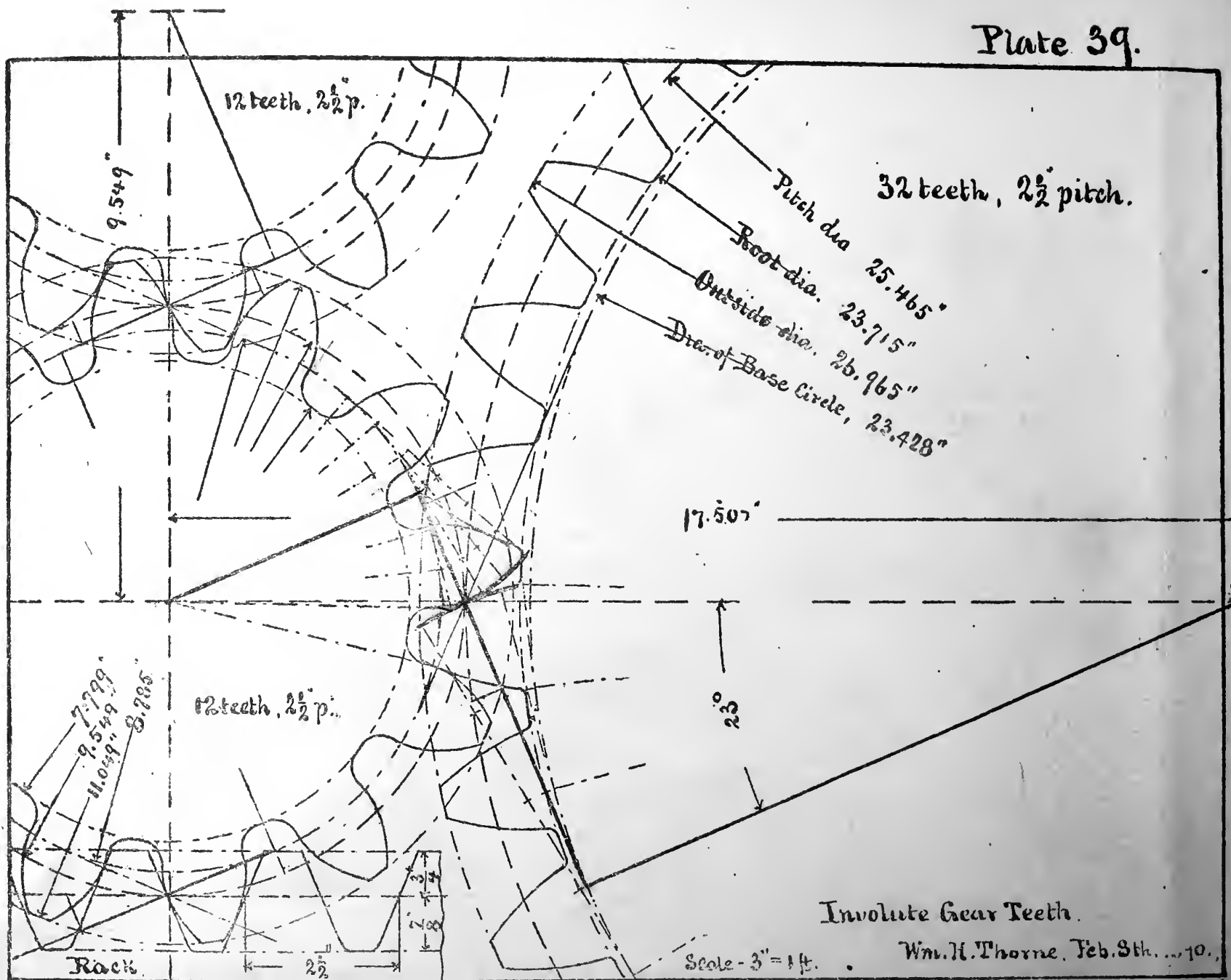



*PLATE 39*









*PLATE 40*



$2\frac{1}{2}$ " Pitch. Angle  $23^\circ$ .

42t.

33t.

27t.

20t.

12t.

$33.423"$   
P. dia.

$26.261"$   
P. dia.

$21.486"$   
P. dia.

$15.915"$   
P. dia.

$9.549"$   
P. dia.

$3\frac{1}{4}$   
 $7\frac{1}{8}$   
 $8$

$1\frac{1}{8}$

$1\frac{1}{16}$

$1\frac{1}{16}$

$1\frac{1}{8}$

$62^\circ$

$4.032"$

$3.357"$

$2.571"$

$23^\circ$

$5.047"$   
 $7.9"$

$6.032"$

$4.981"$

$3.771"$

$1.671"$   
 $2.375"$

Involute Teeth by Circular Arcs.

Scale,  $3" = 1ft.$

Wm. H. Thorne, Feb. 15th. 1890.

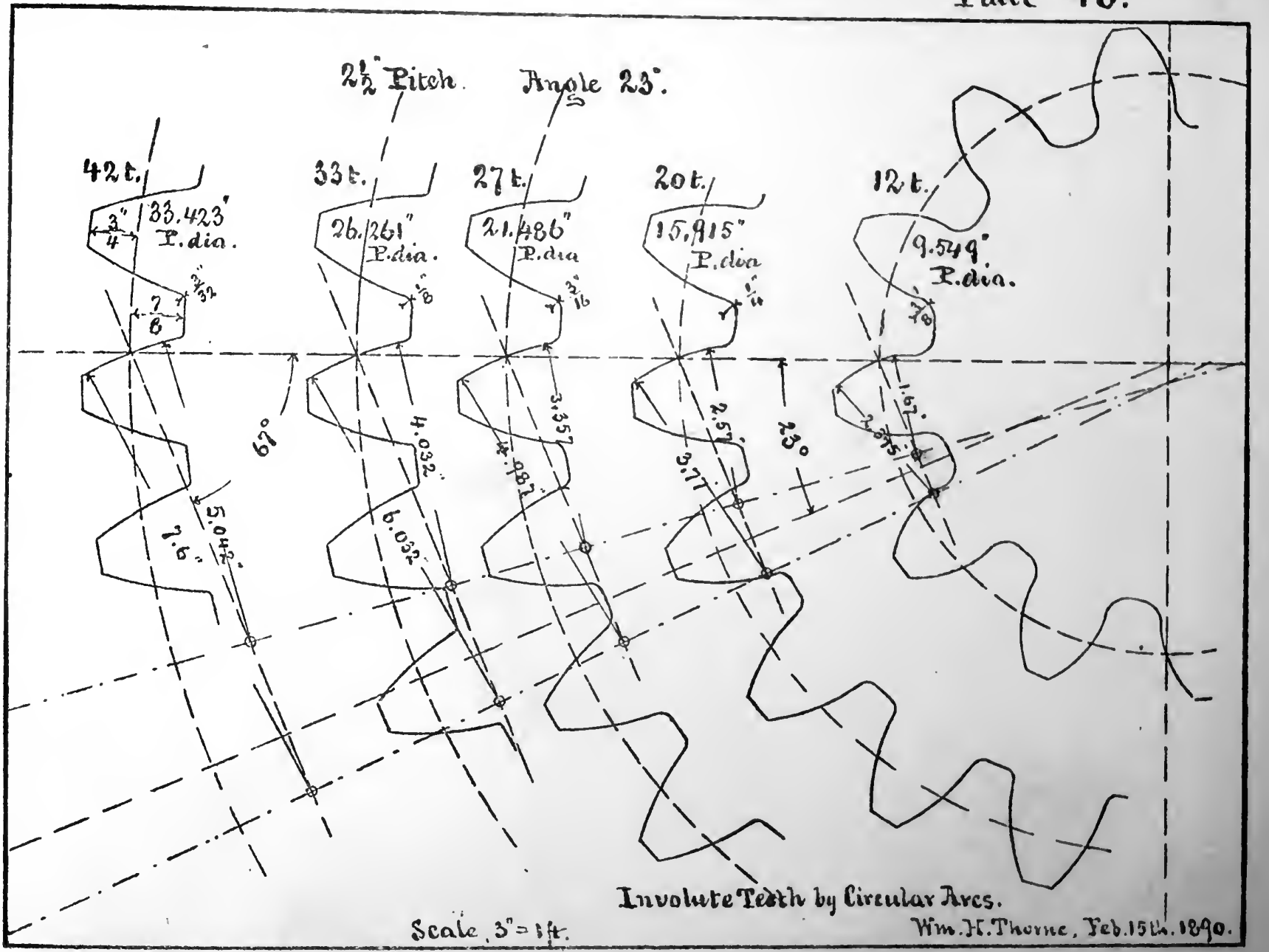
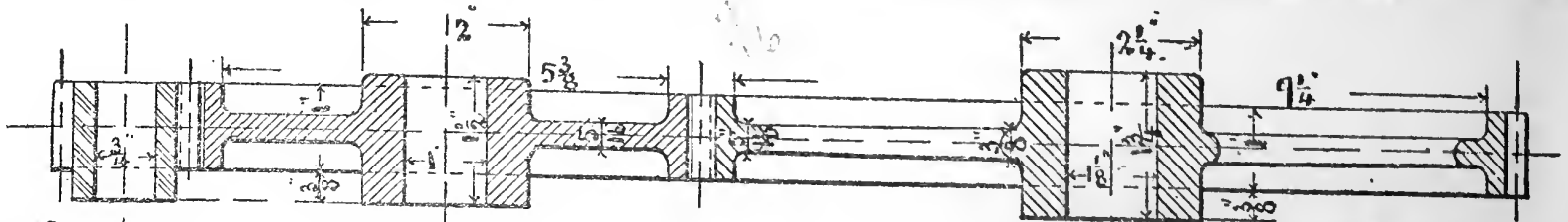



*PLATE 41*







12t. 8 per in.  
 $1\frac{1}{2}$ " Pitch dia.  
 1.735" Outside dia.  
 1.225" Root dia.

44t. 8 per in.  
 $6\frac{5}{8}$ " Pitch dia.  
 6.350" Outside dia.  
 5.850" Root dia.

80t. 8 per in.  
 10" Pitch dia.  
 10.235" Outs. dia.  
 9.725" Root dia.

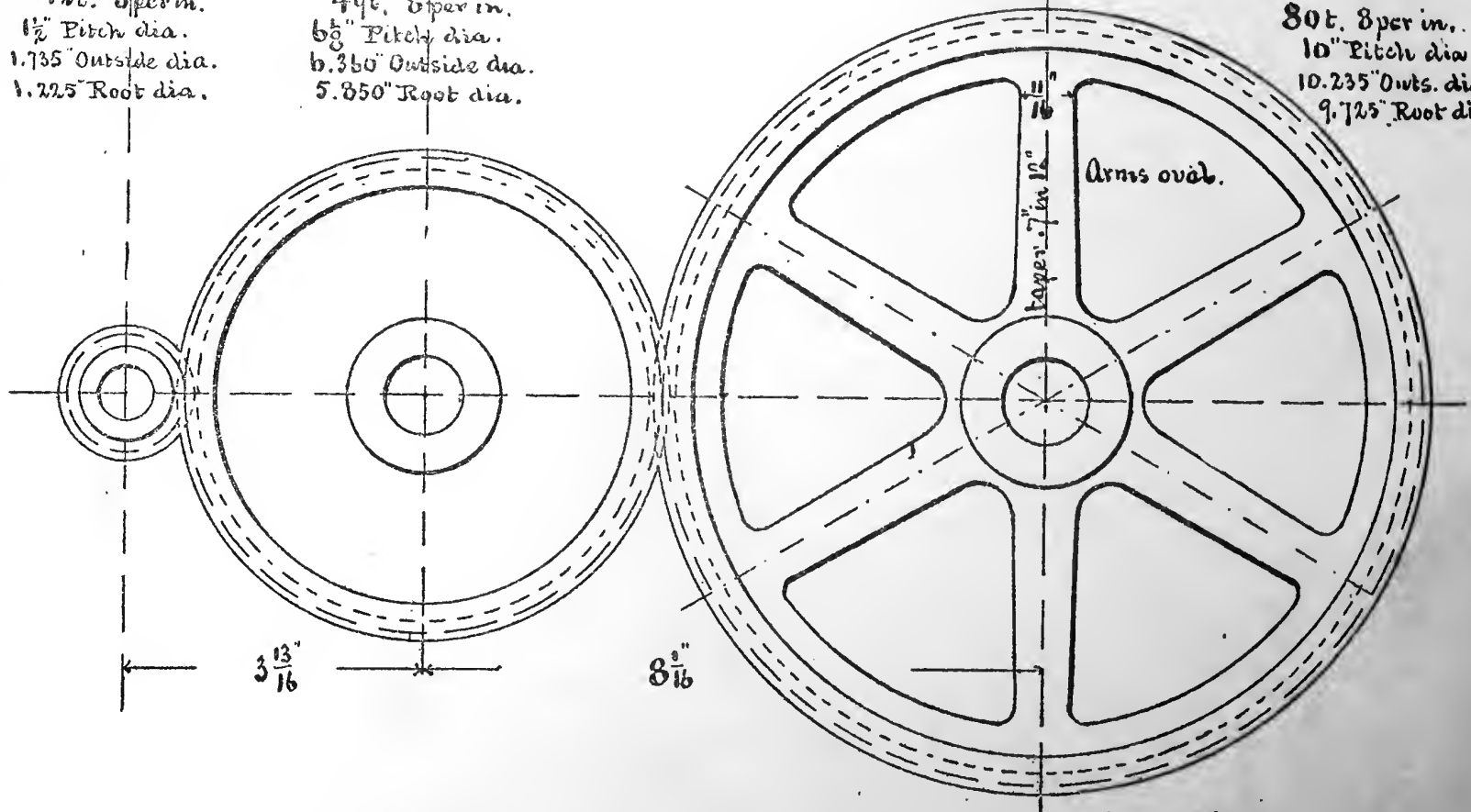

Scale, 3" = 1 ft.

Spur Wheels.  
 Wm. H. Thorne. 2.22.90.





*PLATE 42*



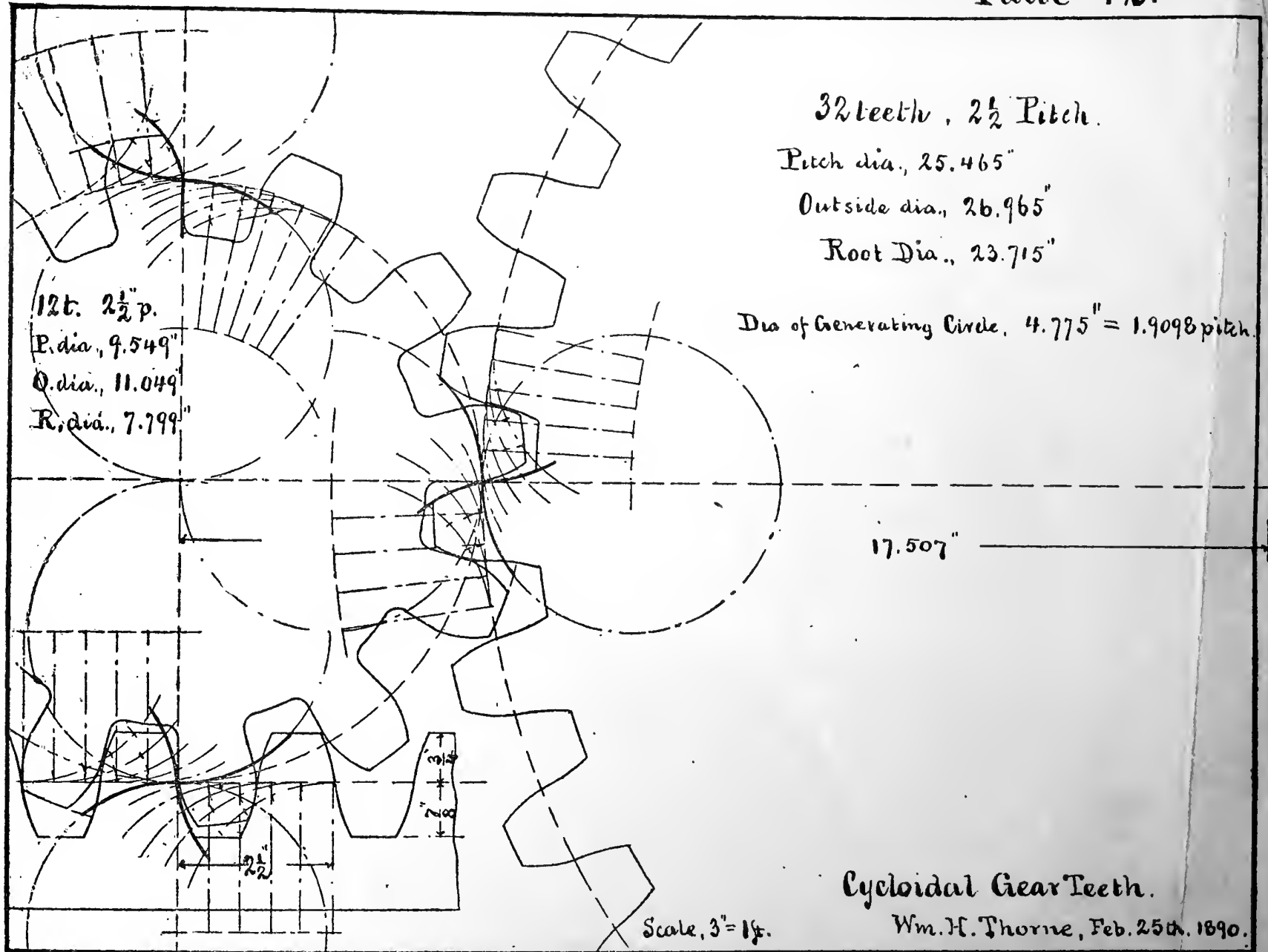
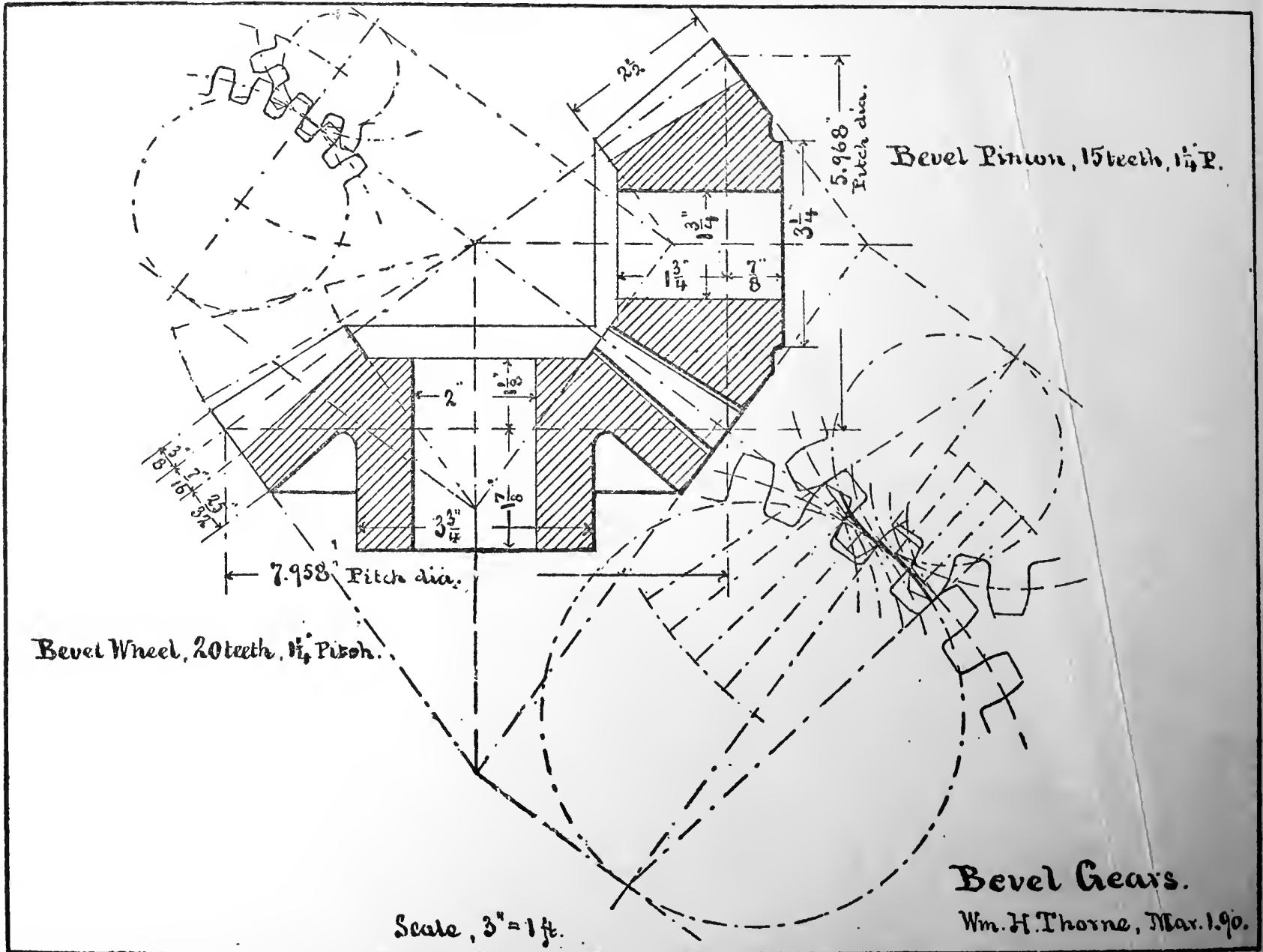



*PLATE 43*







Bevel Pinion, 15 teeth,  $1\frac{1}{4}$ " P.

Bevel Wheel, 20 teeth,  $1\frac{1}{4}$ " Pitch.

Bevel Gears.

Wm. H. Thorne, Mar. 1.90.

Scale, 3" = 1 ft.











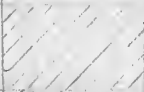

- 45° -

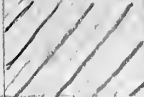
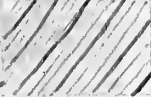
	Iron	Steel	Compositions such as. Brass and etc.
Cast.			
Wrot			

LIBRARY OF CONGRESS



0 019 973 603 6