

T353  
W6  
1912

A COURSE IN  
THE PRINCIPLES OF  
MECHANICAL DRAWING

---

WHITMORE



A COURSE IN  
THE PRINCIPLES OF  
MECHANICAL DRAWING

BY

JAMES B. WHITMORE

Superintendent of Drawing and Shop Courses in the West Technical High School, Cleveland, O.  
Formerly Head of Department of Drawing and Architectural Engineering  
Pennsylvania State College



THE CHAMPLIN PRESS  
COLUMBUS, OHIO  
1912

T 353  
W 6  
1912

Copyright 1911.  
Copyright 1912.

By

James B. Whitmore

01

## PREFACE

---

These notes are especially designed to meet the needs of the Department of Drawing and Architectural Engineering of the Pennsylvania State College, for a comprehensive course in the principles of Mechanical Drawing. In this subject, the large number of students which each instructor in the department is required to handle, prevents, to a large extent, the individual instruction which should supplement a text-book, if ultimate success is to be achieved. This difficulty is met, in the present instance, by outlining in detail, the fundamental steps necessary to perform each prescribed operation. Outlining the method of procedure also overcomes the difficulty

experienced by the average student in his attempt to gain in speed, by eliminating the large amount of time which he wastes in not going about his work in a systematic manner.

The author desires to express his thanks to Messrs. G. D. Barbey, H. M. Glazier, and W. P. Loomis, for much valuable help with the text. He also wishes to express his obligations to Theo. Altenecker & Co. and F. Weber & Co. for most of the instrument cuts in Chapter I.

J. B. W.

State College, Pa.  
Sept. 1, 1911.

# CHAPTER I.

## SELECTION OF DRAWING INSTRUMENTS AND MATERIALS

---

### Choice of Instruments.

**The Quality** of the drawing instruments, used by the student or professional man, determines, to a large extent the form, accuracy, speed, and the ultimate success of his work. The ease with which the student progresses to perfection in the manual dexterity of the draftsman's art, depends entirely upon the quality of his instruments as to material, design, construction, and finish. The ordinary student can turn out excellent drawings with the best of instruments but it takes the exceptional student to turn out the same kind of work with poor instruments. Since the engineering student will continue to make use of his drawing instruments thruout his active professional career, their first cost is secondary in comparison to their quality. The quality of the instruments should therefore be such that they will retain all of their original perfection thruout a lifetime of hard usage. It is true economy for the student to pay the first cost for perfection in these qualities, providing he is certain that he is obtaining them. The original investment of the student in drawing instruments, if wisely made, will never have to be duplicated.

While it is perhaps unnecessary to call the attention of professional draftsmen to the importance and advantage of using first class instruments, it is desirable, however, to warn the student, the apprentice, and the young engineer, against the purchase of cheap instruments. As the essential qualities of first class instruments are visible only to those experienced in their purchase, it is easy, for unscrupulous manufacturers to slight the finer details and turn out very poor instruments

which have every appearance of being first class. Such instruments will not stand up under even ordinary usage. To the student they will prove a constant source of vexation and delay in the execution of his work. The prospective buyer is induced to invest in these "just as good" kind of instruments on the strength of the large discounts offered, which, while making them appear as a desirable purchase, really enables the dealer to make more on their sale than he would on the sale of first quality instruments.

The following bulletin has been prepared, by the Department of Drawing, to set forth clearly the specifications concerning the purchase and use of drawing instruments by students in the several departments of the School of Engineering, which specifications were adopted by the Faculty of the School of Engineering, July, 1909.

### Kinds of Instruments Acceptable.

The various brands of instruments which are recognized by the Faculty of this school are:

Alteneader, manufactured by.....T. Alteneader & Son  
Gem Union, manufactured by.....E. Dietzgen & Co.  
Paragon, manufactured by.....Keuffel & Esser Co.  
Kern, manufactured by.....Kern & Co.  
Richter, manufactured by.....Richter.  
Riefler, manufactured by.....Riefler.  
Key Brand, manufactured by.....Keuffel & Esser Co.  
799A, manufactured by.....E. Dietzgen Co.

This list comprises the makes as recognized by the Faculty at the present time, and does not in any way cut out instru-

ments or materials of equally good characteristics as those here specified. There are, however, instruments on the market that are unsatisfactory, and the student is especially requested not to purchase any instruments without consultation with the Head of the Department of Drawing.

The student is also advised to purchase from dealers who are responsible and who will make good any imperfect sets or parts within a reasonable time after purchase.

Special care should be taken, by the purchaser, to see that every piece of each set of instruments purchased carries the imprint of the manufacturer's name or brand.

#### Instrument Sets.

The instruments shall be put up in full and partial sets. A full set of instruments shall consist of the following:

- 1—5" Hair Spring Dividers.
- 1—6" Compass, with Fixed Needle Point, Pen, Pencil Point and Lengthening Bar.
- 1—3½" Steel Spring Bow Dividers.
- 1—3½" Steel Spring Bow Compass.
- 1—3½" Steel Spring Bow Pencil.
- 1—4½" Drawing Pen with spring upper blade and Aluminum Handle.
- 1—5½" Drawing Pen with spring upper blade and Aluminum Handle.
- 1—German Silver Box of 5H Leads for the Compass.
- 1—Folding Flap or Bar Lock Case.

A partial set of instruments for students in Engineering, Mining and Chemistry Courses, shall consist of:

- 1—5" Hair Spring Dividers.
- 1—6" Compass, with Fixed Needle Point, Pen, Pencil Point and Lengthening Bar.
- 1—5½" Drawing Pen with spring upper blade and Aluminum Handle.

1—German Silver Box of 5H Leads for the Compass.

1—Folding Flap or Bar Lock Case.

A partial set of instruments for students in Agriculture shall consist of:

- 1—6" Compass, with Two Steel Points, Pen, Pencil Points, Needle Point and Lengthening Bar.
- 1—5½" Drawing Pen with spring upper blade and Aluminum Handle.

Students are advised to purchase the full set of instruments as above outlined; but, in case they do not feel able to purchase the full set outright, they are advised to purchase partial sets of the better grade instruments.

In case any student purchases a set of either of the last two brands listed in this bulletin, he will be expected to see that the Drawing Pen is of a quality included in one of the first six sets listed above, and as acceptable as one of those sets.

#### Drafting Materials.

Students are to supply themselves with the following materials:

- 1—20"x26" Drawing Board, not less than 9-16" nor more than 13-16" in thickness to be made of well seasoned, straight grained white pine, free from sap and knots, neither varnished nor shellaced, with end cleats of the same wood to be tongued and grooved to the ends of the board.
- 1—24" T-square, Mahogany blade Ebony lined, or Maple blade Xylonite lined.
- 1—French Irregular Curve, Xylonite.
- 1—45x45x8" Triangle, Xylonite.
- 1—30x60x10" Triangle, Xylonite.
- 1—Pencil Eraser.
- 1—Circular Ink Eraser.
- 1—Dozen Thumb Tacks, 5-16" stamped head.

- 1—Sand-paper Block Pencil Pointer.
- 1—Penholder.
- 1—2H Drawing Pencil.
- 1—5H Drawing Pencil.
- 4—No. 303 Gillott Pens.
- 4—No. 604 Gillott Pens.
- 4—No. 521 F. Leonard Company Ball Point Pens.
- 1—Metal Erasing Shield.
- 1—Bottle Higgins Waterproof Black Drawing Ink.
- 1—Strong Manila Envelope containing the following:
  - 6—Sheets of 15"x22" white drawing paper of grade equal to Keuffel & Esser Co., Normal Paper.
  - 6—Sheets of 15"x22" yellow detail drawing paper of grade equal to Keuffel & Esser Co., Duplex medium weight.
  - 6—Sheets of 15"x22" tracing cloth of grade equal to the Imperial Brand.
- 1—Box of Pounce.
- 1—Blotter.
- 1—Set of Lettering Plates.
- 1—Notes on Mechanical Drawing, 1912 edition.
- 1—Adams Descriptive Geometry, Parts One and Two.
- 1—Set of Descriptive Geometry Problem Plates.

Students will find it to their advantage not to purchase drawing instruments or supplies of any kind until they have attended their first scheduled exercise in the Department of Drawing, where they will receive more detailed instructions regarding the requirements of this department.

**BRANDS ON INSTRUMENTS.** The student, in order to protect himself, should make certain that each piece of his set of instruments is stamped with the brand of the maker. These brands will appear as follows:-

- Altener....."Altener" or "T. A. & Sons."
- Gem Union....."Gem Union" or "E. D. & Co."

- Paragon....."Paragon" or "K. & E."
- Kern....."Kern & Co."
- Riefler....."Riefler" or "F. W. & Co."
- Richter....."Richter."
- Key Brand....."Key" or a picture of a key.
- 799A....."799A."

Instruments which are not stamped with one of the above designations should not be purchased by the student. In the selection of the instruments, the student should pay particular attention to the prominent features of each, as described below. The catalogues of the large manufacturers will also furnish much additional information.

#### Instrument Sets.

The **Full Set** of instruments, which the specifications require for Engineering, Mining and Chemistry students is shown in Fig. 1. The instrument which is shown at the

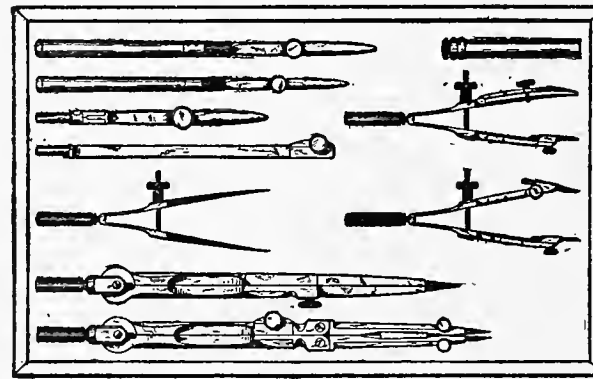

Fig. 1.—Full Set of Instruments.



bottom of the figure is the compass, which is followed by the dividers, the bow spacer, the lengthening bar and pencil point for the compass, and the small and large ruling pen, while to the right of these are shown the bow pencil, bow pen, and lead box respectively.

The **Partial Set** specified for these students, is the above set with the three bow instruments and small ruling pen

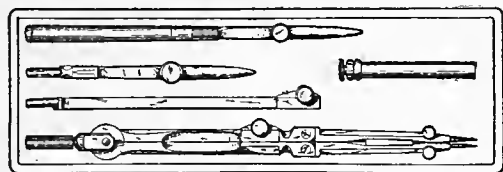

Fig. 2.—Partial Set of Instruments for Agricultural Students.

omitted. The partial set specified for the students in the Agricultural Courses is shown in Fig. 2.

**Professional Set.** After graduation, the student who takes up the career of the professional draftsman will undoubtedly desire to add the small compass pen, the small

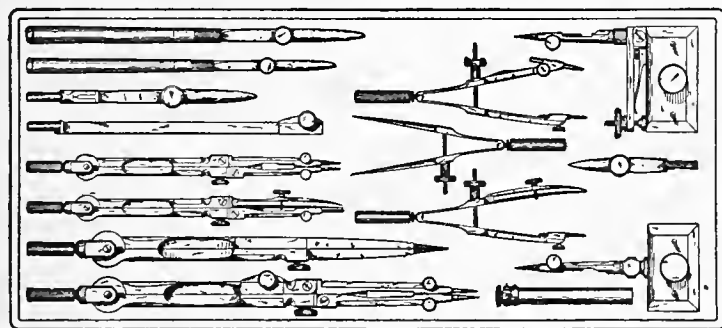

Fig. 3.—Professional Set of Instruments.

compass pencil, and the beam compass parts, to make the set shown in Fig. 3.

### The Compass.

**Instrumental Patterns.** The original instrument pattern is shown in A, Fig. 4. This original pattern has been modified in recent years to the round and flat patterns shown

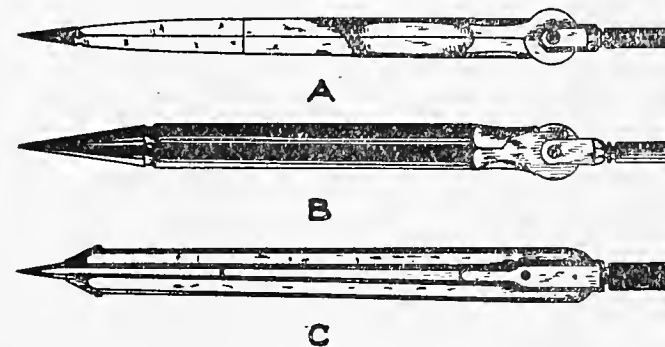

Fig. 4.—The Three Patterns of Instruments.

in B and C respectively. The pattern of instruments selected is more a question of personal preference than anything else, as the pattern with which a draftsman is the most familiar is the one that he will recommend. The A pattern finds the greatest favor among draftsmen and is the one adopted for the Alteneider, Gem Union, Paragon, Kern, Key, and 799A brands. The B pattern is next in favor and is the one adopted for the Rieffler and modified Kern brands. The C pattern is the one adopted for the Richter brand.

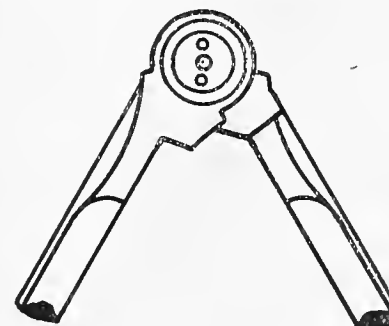

Fig. 5.—The Tongue Joint.

**The Tongue Joint.** The joints used to connect the various parts of each of the drawing instruments together have everything to do with their length of service and the ease of their manipulation. The original tongue joint, Fig. 5, used to join together the two legs of the compasses and dividers, is open to serious objection. The excessive amount of bearing surface between the parts of the tongue joint, makes it hard to operate, and the resultant wear, which takes place on this account, gives rise to lost motion which soon renders the instrument unfit for use.

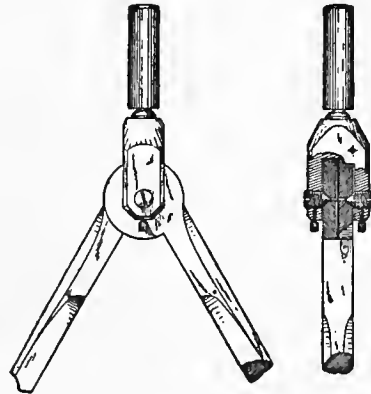

Fig. 6.—The Pivot Joint with Set Screws.

**The Pivot Joint.** The tongue joint was followed by the pivot joint, Fig. 6, in which set screws were used to

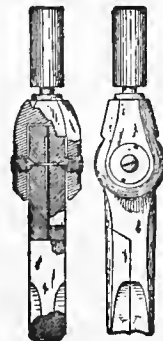

Fig. 7.—The Pivot Joint with Lock Nuts.

hold the pivot screws in place. Later there was designed the pivot point shown in Fig. 7, in which thin lock nuts were used to hold the pivot screws in place. The pivot joint overcomes all of the disadvantages inherent in the tongue joint. In choosing between the two methods of holding the pivot screws in place, the set screw method is to be preferred. In the set screw type the pivot screws can be accurately fastened in place without danger of changing their adjustment, while this is very difficult to accomplish in the lock nut type. As only a part of the instruments having the yoke handle are pivot joint instruments, care must be exercised in their selection.

**The Straightening Device,** shown in Fig. 8, is a flexible connection between the yoke and the legs of the compass or dividers, which serves to keep the handle on the yoke

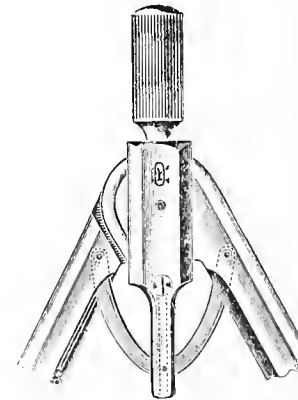

Fig. 8.—Straightening Device.

always in a vertical position as the opening between the legs of these instruments is changed. While this device is intended to add to the ease of manipulating these instruments, it only adds to the complication of the pivot joint and is not to be recommended for general use.

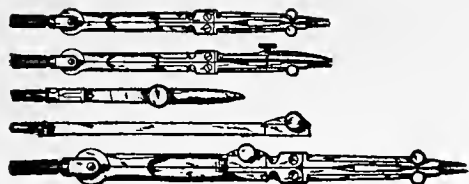

Fig. 9.—Compasses.

**The Compass**, Fig. 9, is made in two styles, the interchangeable and fixed. In the interchangeable style, shown by the large compass, the needle point leg is fixed to the instrument, while the pen, pencil, and lengthening bar parts are removable. In the fixed style, shown by the smaller instruments, both the needle point leg and the pen or pencil point legs are fixed in the instrument. The interchangeable variety is the one usually sold in the larger sizes. In the smaller sizes the fixed variety is to be preferred, although the small interchangeable instruments will also be found very convenient. Either of the smaller types can be used to advantage for the greater part of the work usually done with the bow instruments. The length of the compass, as well as of the dividers, is taken as the overall length exclusive of the yoke, i. e. a  $5\frac{1}{2}$ " compass is  $5\frac{1}{2}$ " long without the yoke.



Fig. 10.—Compass Leg Joints.

**Compass Leg Joints.** The joint, used in the compass leg for holding the interchangeable parts (pencil point, pen point, and lengthening bar) in place, is shown in its various styles in Fig. 10. In A is shown the insertion piece with pentagonal shank, which was modified to the half round shank shown in B. In both these styles the shank is held

in place by small set screws, which is open to the objection that any wear in the joint renders the set screw incapable of holding the parts rigidly in place. Part of this difficulty is overcome in the C type, by using a clamp screw in place of the set screw. The addition of the feather key, in combination with a slightly tapered round shank fitting into a tapered round socket and held in place by the clamp screw, has resulted in the almost perfect joint shown in D.

**The Pencil Leg** shown in Fig. 11, is not desirable since it is impossible to clamp a piece of hard lead in place tight enough to prevent its slipping up into the leg when the compass is in use. This defect proves very annoying to the careful draftsman. Fig. 12 shows the ideal method of holding the lead in the pencil leg, and is the type recommended. The proper design of needle point leg is also shown in Fig. 12.



Fig. 11.—Old Style Pencil Leg.

Fig. 12.—Improved Pencil Leg.

**The Pen Leg**, shown in Fig. 13, with the spring blade, is to be recommended over all types of pens with a hinge in the upper blade. The only objection to this pen is the trouble experienced in retaining the original setting of the pen when it is opened for cleaning. This difficulty, while not a serious one, has been overcome in the type shown in Fig. 14. Either style can be recommended for purchase.

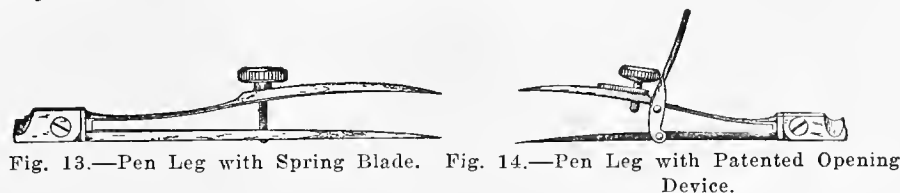

Fig. 13.—Pen Leg with Spring Blade. Fig. 14.—Pen Leg with Patented Opening Device.

The **Fixed Needle Point Leg** of the compass can be had either with or without the hair spring adjustment. This device, Fig. 15, is made by mounting the needle point leg upon a spring blade which is fixed to the compass. By means

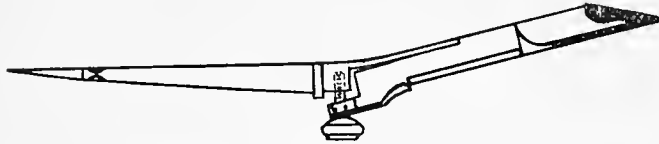

Fig. 15.—Section of Leg Showing Hair-spring.

of a thumb screw controlling the spring blade, the needle point can be moved thru a very small distance. In this manner, a perfect setting of the instrument can be made with greater ease than is possible without the use of the hair spring.



Fig. 16.—Needle Points.

**Selection of the Compass.** In the selection of the compass be sure that it has a pivot joint, with handle; that the best method is used for holding the insertion joints, the lead point, and the needle point; that both the pivot joint, as well as all the other joints, work smoothly; that the clamping screws have perfect threads; that the needle point is as shown in Fig. 16; that the interchangeable parts can be

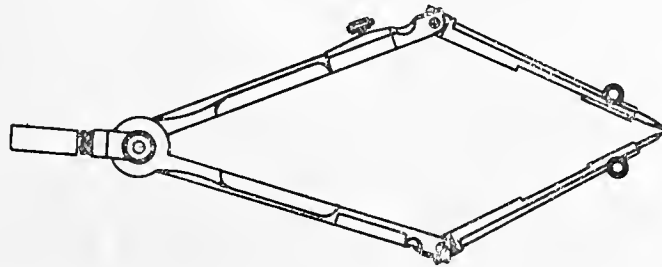

Fig. 17.—Compass in Position for Testing Alignment.

rigidly clamped into place; that the instrument, when opened as shown in Fig. 17, has the ends of the legs in perfect alignment. If they are not in perfect alignment reject the instrument.

### Dividers.

**Styles of Dividers.** Dividers are made in two styles. In Fig. 18, the first of the three instruments shown is the plain style, with stiff legs. The second of the instruments

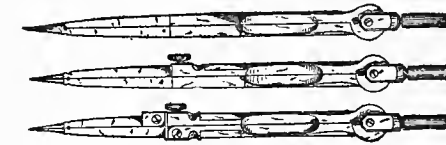

Fig. 18.—Styles of Dividers.

is equipped with one stiff and one hair-spring leg, called the hair-spring style. Either of these styles can be provided with a knuckle joint in each leg, as shown in the third instrument.

**Selection of Dividers.** In the use of the plain dividers difficulty is experienced in obtaining a fine setting between the needle points. This difficulty is overcome in the hair-spring dividers by the use of the thumb-screw adjustment, which allows of a very delicate setting of the instrument. For this reason the hair-spring type is recommended for all work. The dividers should have a pivot joint with yoke handle. The points should be extremely sharp and of the same length. They should also be circular in section instead of triangular as is sometimes the case.

### Bow Instruments.

**Styles of Bow Instruments.** There are three bow instruments:—the bow spacer, the bow pencil, and the bow pen. The original style of these three instruments is shown in Fig. 19. This style, with the outside thumb nut, has been modified



Fig. 19.—Bow Instruments with Outside Thumb Nut, (Original Style).

by placing the thumb nut between the legs as shown in Fig. 20. Another style is the hook-spring instrument, Fig. 21, with

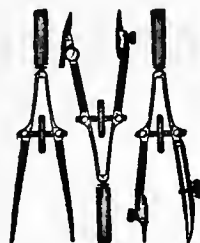

Fig. 20.—Bow Instruments with Inside Thumb Nut.

the thumb nut either inside or outside of the legs. The original style, Fig. 19, finds the most favor among professional draftsmen. These instruments may be secured in several sizes. The 3½" size is to be preferred for the general run of work.



Fig. 21.—Hook-spring type of Bow Instrument.

**Selection of the Bow Instruments.** Care should be taken to see that the thumb nut works easily on the screw; that the screw threads are perfect; that the spring legs are stiff enough to open the instrument to the full length of the screw; that the points of the bow spacer are sharp and of the same length; that the needle point provided in the bow pen and pencil is shouldered on both ends as shown in Fig. 16; and that the adjusting screw in the pen blade and the one in the lead holder work smoothly. Some draftsmen prefer to purchase a bow spacer and a 4½" standard compass with

pen, pencil, and lengthening bar, to take the place of the bow pencil and bow pen. The leads provided for the large compass and bow pencil should be 5H. It is the usual practice to supply very soft lead which is useless for good work.

### Ruling Pen.

**The Ruling Pen,** Fig. 22, requires considerable care in its selection, as it is almost impossible to turn out good drawings with a poor ruling pen. The aluminum handle is preferable to the usual ebony or bone handle because it does not break and thus render the instrument useless. The pen should also be of the type with spring upper blade as shown



Fig. 22.—Ruling Pen.



Fig. 23.—Spring Upper Blade of Ruling Pen.

in Fig. 23. Several devices, Fig. 24, have been patented, to enable the pen to be opened for cleaning purposes without disturbing the setting, but have not come into general use.

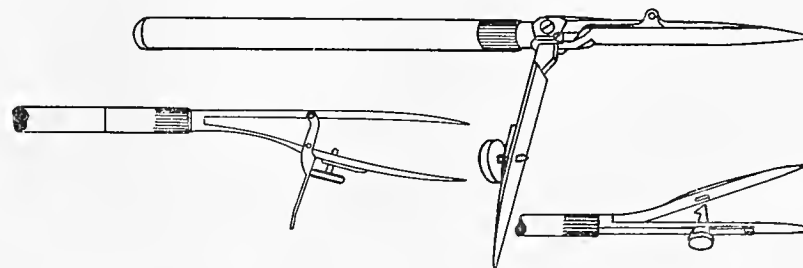

Fig. 24.—Ruling Pens with Special Device to Facilitate Cleaning.

Two sizes of ruling pens should be purchased, the large or 5½" size for ordinary work, and the small or 4½" size for complicated work. In selecting the ruling pen be sure that the points are of the same length and oval in shape.

The Case selected to contain the instruments can be of either the bar-lock or folding flap style. The former is the cheaper, but the latter gives better satisfaction in use. If the student does not desire to purchase a case of either type, he can very easily make his own wrapper for the instruments out of a piece of chamois skin, by sewing loops on one side to receive each of the instruments.

#### Drawing Materials.

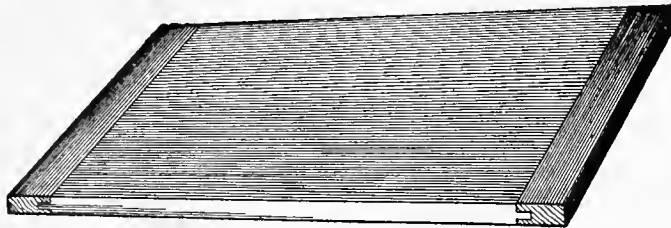

Fig. 25.—Drawing Board.

The Drawing Board, Fig. 25, should be selected with care and, in its main essentials, should closely follow the specifications. See that the board selected is very soft, as vexation and difficulty will be experienced in the insertion and withdrawal of thumb tacks from a board of hard wood. The short edges of the board should be straight and free from small elevations or depressions. Do not purchase a board which has cleats fixed to one face. The end cleated board is better, and at the same time, provides two sides for drawing purposes.

The T-Square, Fig. 26, comes in two styles. One has either a mahogany, maple, or pear wood blade, with an opaque

ebony edge, while the other has a blade of one of these materials with a transparent celluloid edge. In either of these styles, the blade can be had with the fixed or movable head. For

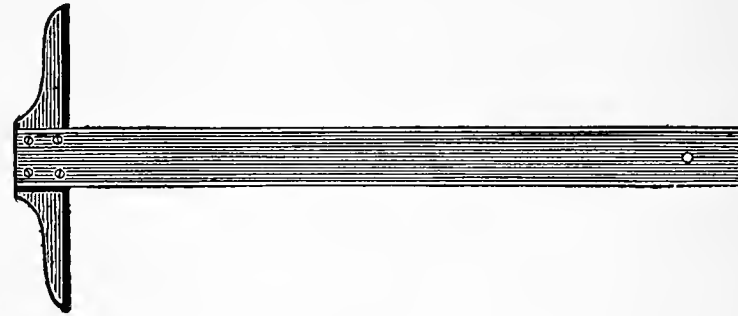

Fig. 26.—T-square with Fixed Head.

ordinary use, the T-square with fixed head, Fig. 26, is preferable, but at times it is desirable to make use of the T-square with a movable head, Fig. 27. The celluloid edged T-square

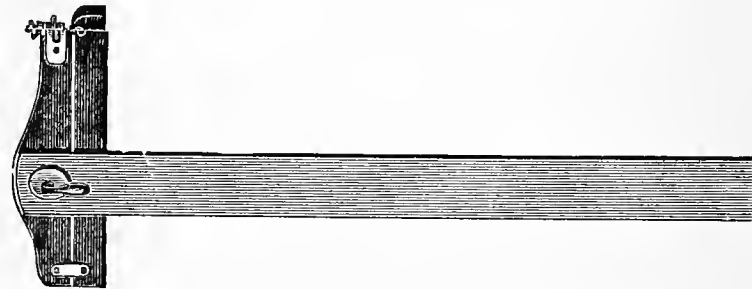

Fig. 27.—T-square with Movable Head.

gives the greatest satisfaction, because its transparent edge makes it easier to manipulate. It costs considerably more than the ebony edged T-square. Care should be exercised in the selection of a T-square to see that the edges of the blade are free from nicks; that they are perfectly straight; and that the blade is firmly fixed to the head. It is not essential that both edges of the blade be parallel, or that the blade be exactly perpendicular to the head. If a long T-square is desired, the

blade should be fixed to the head as shown in Fig. 28, that is, the blade is fastened below the center of the head. To test



Fig. 28.—English T-square.

the blade of the T-square for straightness, draw a fine line its full length, and then, by reversing the T-square, see if the same edge of the blade coincides with the line as drawn. If it does not, the blade is not straight, and the T-square should be rejected.

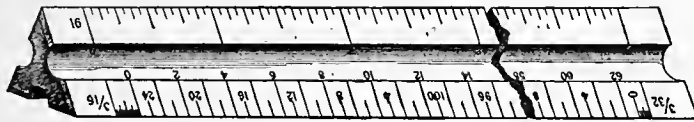

Fig. 29.—Architect's Scale.

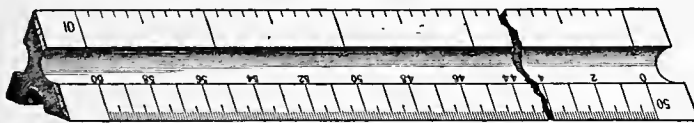

Fig. 30.—Engineer's Scale.

**The Scale** can be obtained in two types;—one the Architect's scale, Fig. 29, divided into proportional feet and inches, and the other, the Engineer's scale, Fig. 30, divided into tenths, twentieths, etc. of an inch. The Architect's scale is used in all Mechanical, Architectural, and Structural drafting, while the Engineer's scale is used in plotting surveys, drawing maps, etc., and in the solution of graphical problems in Mechanics

and Structures. The scales are usually made of boxwood, with or without a white celluloid edge, upon which the divisions are shown. The white edged scales are easier to read than those of plain boxwood. Metal scales are extremely hard on the eyes, and are not recommended. Each type of scale can be secured in the ordinary triangular shape, Fig. 29, with all the scale divisions placed on the same instrument; or flat shaped, Fig. 31, with one or more scale divisions placed on

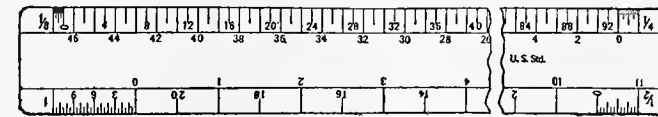

Fig. 31.—Flat Style of Scale.

each instrument. In selecting the flat type of scale, the reverse bevel edge type, Fig. 32, is preferable to the style shown in

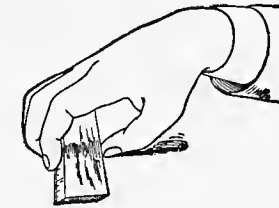

Fig. 32.—The Opposite Bevel Scale.

Fig. 31. For professional work it is best to select the flat scale with one set of scale divisions to each instrument, which requires six to eight scales for a complete set. For student work the triangular type is preferred, even with the difficulty experienced in getting the different scale divisions confused. This difficulty is easily overcome if care is exercised in the use of the instrument. The scales are furnished in different lengths, but the twelve inch length should be purchased. When selecting a scale, use care to see that the divisions are clear and sharp and that the edges of the scale are straight and free from nicks.





30-60 Degree Triangle.

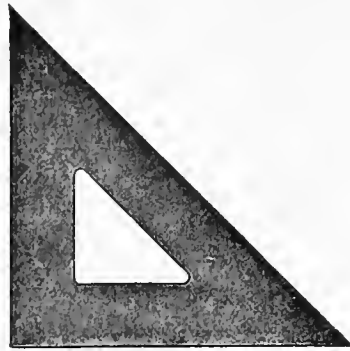

45-45 Degree Triangle.

Fig. 33.

**Triangles.** In Fig. 33 are shown the two forms of triangles in common use. The first is the 30-60 degree form, and the other is the 45-45 degree form. Transparent triangles, made of celluloid, should invariably be purchased, as the wooden or hard rubber variety are a constant source of trouble. The celluloid triangle should be at least 1-16" in thickness, the edges should be straight and true, and the angles should be accurate. Purchase only the better grades, as the cheaper kinds become opaque and then give the same difficulty in use as the wooden variety. To test the angles of a triangle, construct 30, 60, 45, and 90 degree angles geometrically, and test the corresponding angles of the triangle by means of these constructed angles.

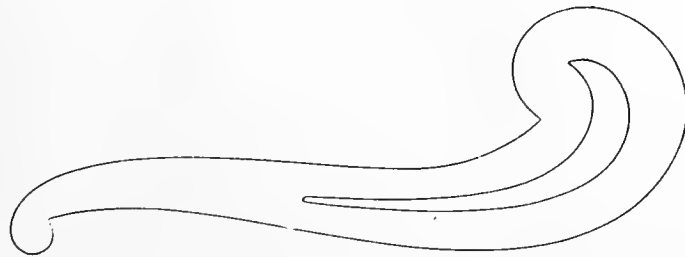

Fig. 34.—French Curve.

**The French Curve** selected should be of celluloid, 1-16" in thickness, and of the type shown in Fig. 34. Flexible curves are sometimes used. These are made from lead or soft copper wire and may be bent to fit any desired curve.

**The Drawing Pencils** are specially prepared for the service intended, and may be had in various degrees of hardness. The 6B grade is very soft and black, followed in order of hardness by 5B, 4B, 3B, 2B, B, HB, F, H, 2H, 3H, 4H, 5H, 6H, 7H, and 8H which is extremely hard. The grades below H are used for pencil sketching and Architectural work, while the grades from H up, are used in Mechanical drawing. The 5H and 6H are the best for ordinary detail work, while the H and 2H are the best for lettering and sketching. The Kohinor and Faber pencils are the finest in quality, and, while they cost more than the other varieties, they give increased satisfaction and length of service.

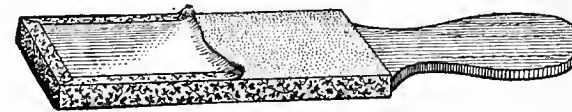

Fig. 35.—Pencil Sharpener.

**A Pencil Sharpener** is to be provided. This may be a block of very fine sand-paper, Fig. 35, or a fine flat file.

**Pens.** The assortment of pens for lettering should include the three following varieties:—coarse, F. Leonard ball point pen No. 521F; medium, Gillott No. 604; and fine, Gillott No. 303.

**The Penholder** should be provided with a cork grip. This grip should be small enough to enter the mouth of the ink bottle with ease, but not so small as to make it necessary to cramp the fingers when using the penholder.



**Ink.** The drawing ink selected is to be Higgins' black waterproof drawing ink, as it is the most satisfactory in every respect. The stick India ink is preferred to the prepared liquid ink for very fine drawings. It is used considerably in Architectural work but is not recommended for ordinary drafting, on account of the difficulty experienced in grinding the ink for use.



Fig. 36.—Solid Head Thumb Tack.

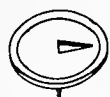

Fig. 37.—Thumb Tack with Point Stamped from Head.

**Thumb Tacks.** There are two varieties of thumb tacks, one with the point inserted in the head, Fig. 36, and the other with the point stamped from the head, Fig. 37. Select the latter, and take only those with sharp points and small heads. The first kind costs more but is easier on the T-square edge, provided that the circumference of the head of the tack is beveled to a sharp edge as shown.

**The Drawing Paper** is manufactured in several grades and colors, and in light, medium, and heavy weight. It can be purchased cut into sheets, or in large continuous rolls in any of the following widths—24, 30, 36, 42, 48, 54, and 60 inches. The medium weight yellow duplex detail paper is used for ordinary pencil drawings. White "Normal" paper is used for drawings to be inked. Whatman's cold pressed, hot pressed, or rough, is used for either ink or color work, for fine work, and for water color sketches, in the order named. Bristol board is a smooth white board used

for patent office drawings and for reproductions. In selecting a drawing paper, pay particular attention to its toughness and erasing qualities, and note that the cream, buff, or yellow papers are much easier on the eyes than the white. The cheaper manila papers are not to be tolerated for drawing purposes. For drawings that have to stand hard usage, the paper can be purchased mounted on cloth.

**The Tracing Cloth** purchased should be of the best. The Imperial brand is recommended. In handling tracing cloth, note that moisture or water, coming into contact with the surface of the cloth, will ruin it. Tracing papers are used in place of tracing cloth for duplicating purposes and for preliminary designs. The Alba brand is the best for all around service.

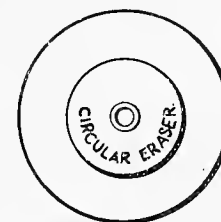

Fig. 38.—Circular Ink Eraser.

**Erasers.** Select a large pencil eraser of red rubber. Rubber manufacturers generally recognize red rubber as the best grade. A circular typewriter eraser, Fig. 38, is recommended in preference to all others. A steel ink eraser knife, Fig. 39, is a handy tool for the draftsman to possess.



Fig. 39.—Steel Eraser.

An **Erasing Shield**, Fig. 40, is a great time saver when complicated erasures are to be made. The metal shield is to be preferred to the celluloid variety.

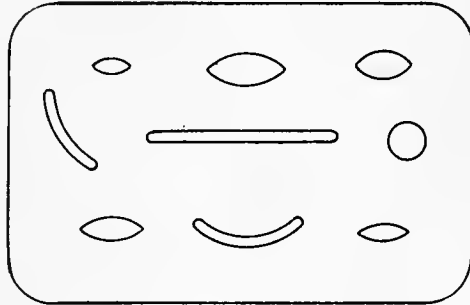

Fig. 40.—Eraser Shield.

A **Penwiper** of lintless cloth should always be available for wiping the pens, and two or three good absorbent blotters should always be on hand for cleaning the ruling pen.

#### Description of Special Instruments.

In addition to the instruments just specified, there are numerous other instruments which the draftsman will find desirable to add to his set as he takes up different lines of work.



Fig. 41.—Detail Pen.

**The Detail Pen.** In Fig. 41, is shown a detail pen which is very convenient for ruling long lines. The desirability of this pen is due to the large amount of ink which it will carry, necessitating less frequent filling than is the case with the ordinary pen.

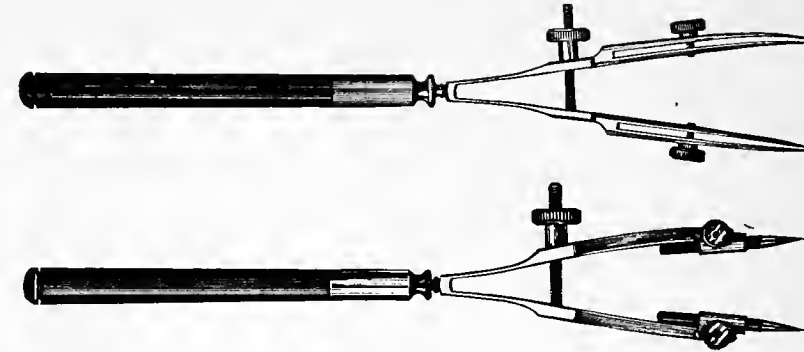

Fig. 42.—Railroad Pen and Pencil.

**The Railroad Pen** and pencil, shown in Fig. 42, is very essential for railroad work, or any other work requiring parallel lines drawn at a comparatively small distance apart. In using this style of pen, the space enclosed between the separate pens, as well as the pens themselves, can be filled with ink, which will permit the drawing of a single heavy line at one operation.



Fig. 43.—Contour Pen.

**The Contour Pen.** The contour or curve pen, Fig. 43, is essential for speed in inking contour lines in map work, and topographical drawing. The pen turns in the hand, and this, together with the peculiar shape of the pen, makes it possible to draw the most irregular curves with ease.

**Dotting Pens.** Various pens are available for inking dotted lines, and are occasionally desirable for making such lines on drawings for reproduction.

The **Drop Pen**, Fig. 44, is a very convenient instrument for drawing small circles, such as rivets on structural drawings. This instrument is to be preferred to the bow instruments for this class of work. The drop pen is not suitable for drawing circles of large diameter.

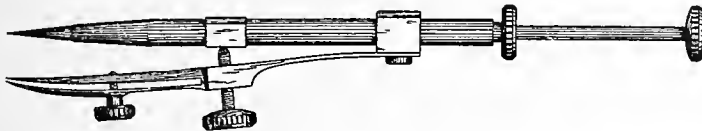

Fig. 44.—Drop Pen.

The **Prick Punch**, Fig. 45, is sometimes preferred to the drawing pencil for pointing off scale distances.



Fig. 45.—Prick Punch.

The **Protractor**, Fig. 46, is desirable for laying out angles which are not multiples of 15 degrees. This instrument

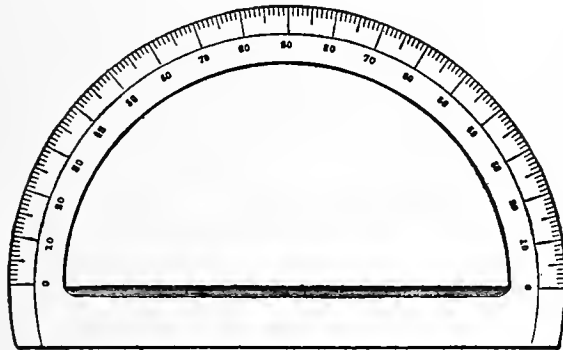

Fig. 46.—Protractor.

is put up in a more convenient shape for use, in the Brown and Sharp protractor, shown in Fig. 47, which has a vernier reading to minutes.

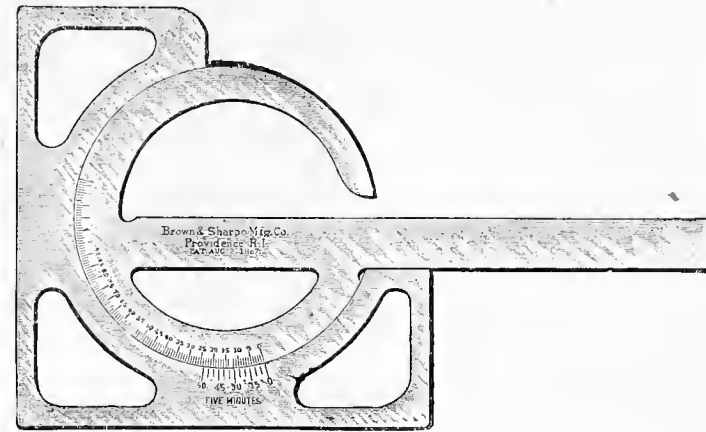

Fig. 47.—Brown and Sharpe Protractor.

The **Payzant Lettering Pen**, Fig. 48, can be obtained in six sizes, graded to draw lines varying in width from medium to very heavy. This pen will prove a valuable addition to the draftsman's outfit, as by its use, a large part of the difficulty in rendering free hand letters in ink is overcome.



Fig. 48.—Payzant Lettering Pen.

The **Beam Compass** is made in two styles, one for use on a wooden bar, Fig. 49, and the other with the needle, pencil, and inking attachment mounted on a metal bar, Fig.

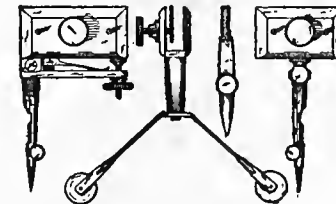

Fig. 49.—Beam Compass, Wooden Bar Type.

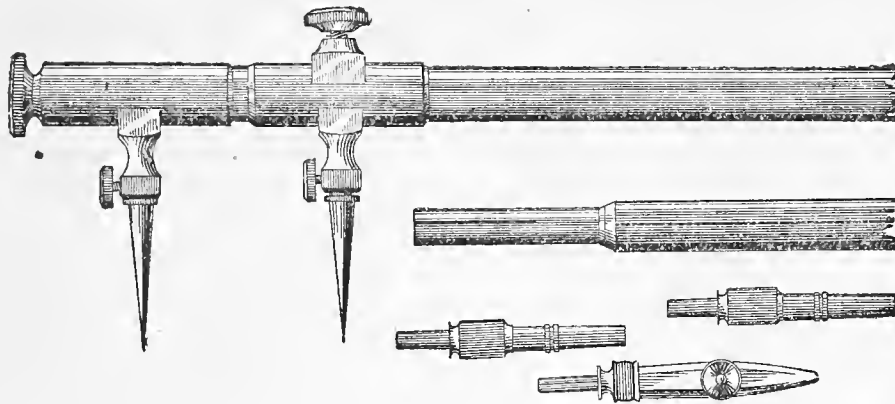

Fig. 50.—Beam Compass, Metal Bar Type.

50. Each style is desirable, with the preference in favor of the metal bar instrument, because the bar, which comes in sections, is always with the instrument when needed. In purchasing a beam compass of either type, be sure that a micrometer device is provided for the purpose of fine adjustment.

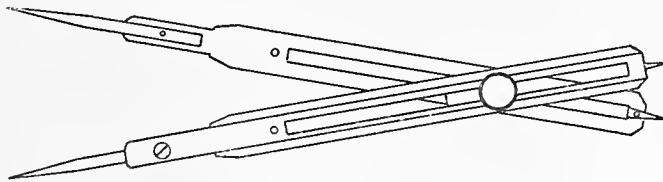

Fig. 51.—Proportional Dividers.

The **Proportional Dividers**, Fig. 51, are useful for reducing or enlarging drawings, as with their aid much time can be saved in transferring dimensions.

**Cross-Hatching Devices.** Various devices are in use to make cross-hatching less irksome, but at best their manipulation is not a time saver, altho their use results in

a greater regularity in the spacing of lines. However, a good draftsman can space cross-hatch lines almost perfectly without the aid of any special device.

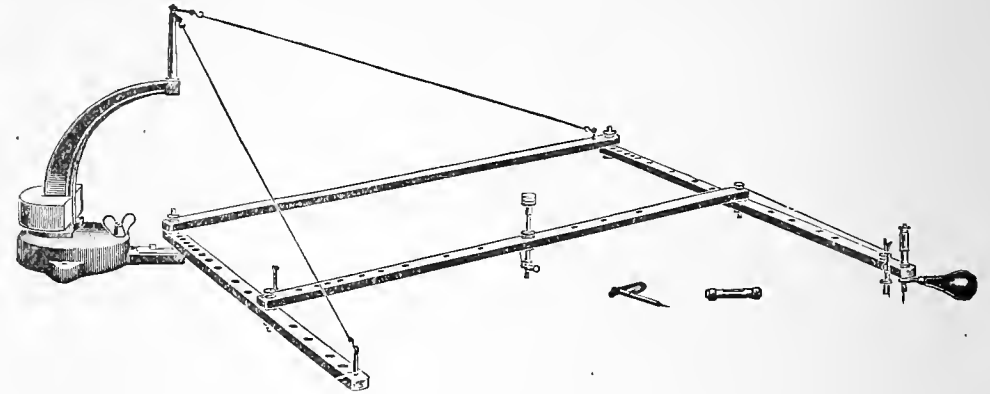

Fig. 52. Pantograph.

The **Pantograph**, Fig. 52, is used for reducing and enlarging drawings, and proves to be a very convenient instrument when a great amount of work is to be done.

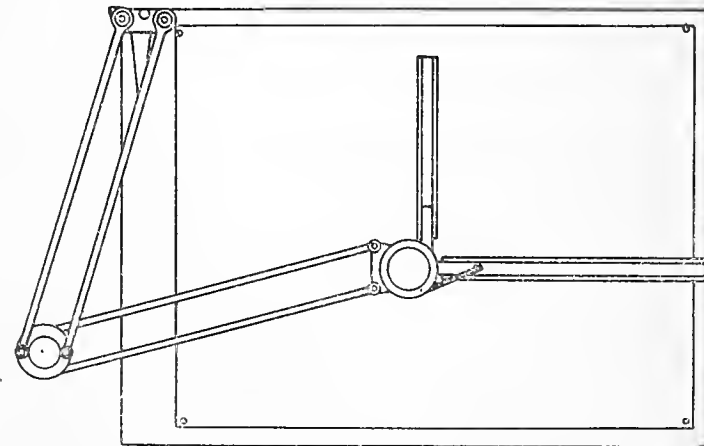

Fig. 53.—Universal Drafting Machine.

**Drafting Machines.** The Universal Drafting Machine, Fig. 53, is the best of a large number of devices on the market for relieving the draftsman of a considerable part of the manual labor required in drawing. This instrument combines the T-square, triangle, and scale, all in one movable arm, which can be made to cover all parts of the drawing board without the expenditure of any more effort on the draftsman's part than it takes to move the T-square about. The head carrying the horizontal and vertical arms is swiveled, which allows the placing of the arm in position to draw any size angle required. This machine is used in a large number of commercial drawing rooms, where it has shown a saving of from 25 to 50% of the time required by the old method of turning out drawings.

The **Steel Straight Edge**, is used in plotting surveys and in drawing long straight lines where greater accuracy is required than can be obtained with the ordinary T-square.

**Special Forms of Triangles** devised for the draftsman's use are illustrated in Fig. 54, known as the Kelsey; in Fig. 55, known as the Rondinella; and in Fig. 56, known as the Technology. There are also numerous other special triangles used for lettering purposes.

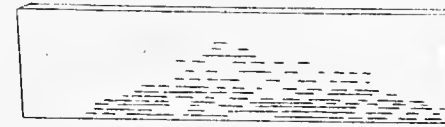

Fig. 57.—Oilstone.

**Oil Stones.** A good Arkansas oil stone Fig. 57, will prove convenient for the purpose of keeping the ruling and compass pens in good condition.

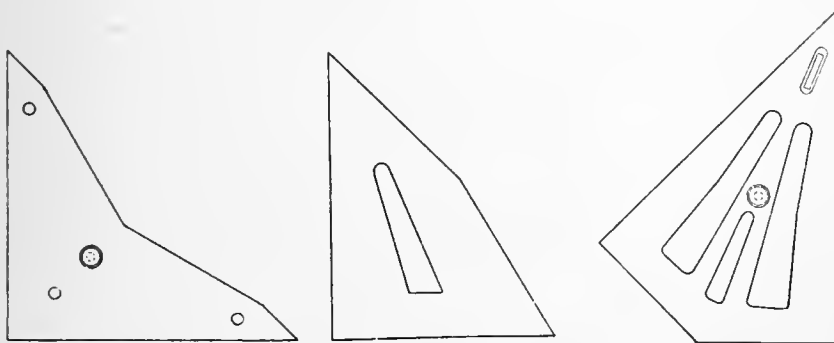

Fig. 54.—Kelsey Triangle.

Fig. 55.—Rondinella Triangle.

Fig. 56.—Technology Triangle.

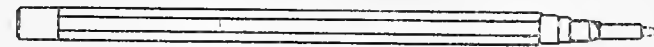

Fig. 58.—Pencil Holder.

The **Pencil Holder**, Fig. 58, with insertable leads, is preferred by some draftsmen to the ordinary drawing pencil. The leads for these holders come in 6" lengths and in all degrees of hardness.

## CHAPTER II.

### CARE OF THE INSTRUMENTS AND MATERIALS

---

**Good Form in Drawing.** Particular attention should be given in beginning the use of drawing instruments and materials to the various details which count for good form in drawing. It is quite essential that correct methods should be cultivated at the start, if one would become proficient in the draftsman's art. Bad form in drawing is very common among draftsmen. This is due mainly to carelessness and lack of knowledge in the essentials at the beginning, causing the formation of bad habits which are very hard to overcome. The habits formed at the very start are the ones that the student will carry out with him to his professional career. If they are habits, of carelessness, indifference, or laziness, they will cause him a vast amount of hardship. He will have to unlearn such habits some day or give way to the man who cultivated, at the start, the habit of always giving quiet, strict attention to the work at hand. In other words, it is necessary to concentrate on the thing to be accomplished, and to get it done with the least possible expenditure of time and energy.

**General Care.** The care of the instruments is the first requisite to good form. They should be kept clean and free from moisture, and always in first class working order. The compass should work freely in the joints without being either too tight or too loose. The same may be said of the dividers. The bow instruments should have a drop of oil placed upon the screw thread to facilitate the easy manipula-

tion of the adjusting thumb nut. The length of service of these instruments depends on the lasting qualities of the spring blade and upon the care taken of the screw thread. It is especially important that the tension on the spring blade be always released before placing the instrument aside. In regulating the thumb nut, be careful not to strip the threads or to damage them in any way. The ruling and compass pens should always be kept properly sharpened and scrupulously clean. The pen when in use should never be laid aside without first cleaning the ink from the blade with a blotter. When it is to be put away for any length of time, the points should be very carefully cleaned. The importance of keeping the pen clean is due to the fact that the ink corrodes the steel points and renders them unfit for use. The small adjusting thumb screws of the pen, compass, and dividers should have a drop of oil placed upon them to make them work easily and keep them from rusting. In laying a pen aside after use, always open the adjusting thumb screw to relieve the tension on the blades. In placing the drawing instruments away, always clean all finger marks, etc. from them. Do not keep the chamois skin, used in cleaning the instruments, in the case, as its property of absorbing moisture will cause the instruments to rust.

**Sharpening the Ruling Pen.** All first grade ruling pens come from the maker sharpened ready for use, and should not require resharpening for quite a while. If, how-

ever, at any time the pen does need resharpening, secure a fine grained Arkansas oil stone for the purpose. Fix clearly in mind the correct shape of the pen before starting to work. Do not grind the pen points on the inside, but do all the grinding on the outside of the blade. Do not grind the point off at a bevel, but grind the point for  $\frac{1}{2}$ " or more up the length of the blade. In grinding, first bring the points just together, without squeezing them any, and, with the stone at right angles with the axis of the pen, grind them to the correct oval shape, being sure that they are of the same length. After this is accomplished, open the pen and grind the outside of the point to a sharp edge. When the entire edge of the point is sharp, remove the burr from the inside of the point by rubbing it lightly over the stone. Be sure that the surface of the stone is in contact with the entire inner surface of the blade, and not merely bearing on the sharp point.

**Care of the Drawing Board, T-square, Etc.** The drawing board should be kept in a dry place. Care should be taken not to cut its surface full of grooved lines in trimming drawings upon it, or to dent its edges. The T-square should never be used to drive tacks, and the working or top edge of the blade should never be used as a straight edge to guide the knife when trimming drawings. Always use the bot-

tom edge of the blade for this purpose. Care should be taken not to jam the head of the T-square against anything, as when the head becomes loose the T-square is worse than useless. The triangles should be kept clean and the edges should never be used for trimming drawings. The scale should be well taken care of in order to keep the edges straight and free from nicks, and its graduations clear and sharp. The drawing paper and tracing cloth are very susceptible to moisture and should be kept in a dry place. Special care should be taken to prevent all forms of moisture from coming into contact with the tracing cloth, as it will render the cloth unfit for use by destroying its inking qualities and rendering it opaque. Drawing ink that has once been frozen is unfit for use. Ink that has become too thick for use should be thrown away and a new supply secured.

**Identification Mark.** Each instrument and piece of material of the student's outfit should have an irremovable identification mark placed upon it in a conspicuous place. This should be done before bringing the outfit into the drawing rooms. Attention given to this matter at the start will save much trouble from the loss of instruments or other supplies.

## CHAPTER III.

### LETTERING

---

One of the primary essentials for a successful rendering of drawings, is the ability of the draftsman to render the descriptive matter, dimension figures, and titles, in a neat, artistic, and finished manner. A poor quality of lettering has spoiled the business getting qualities of a large number of otherwise excellent designs. A fine quality of lettering, combined with the other details which make a drawing pleasing to the eye, has been the means of securing favorable consideration for a well rendered poor design, over better designs that were not so well rendered. It is extremely important that the student make a determined effort, at the outset of his professional career, to become proficient in the rendering of freehand lettering. The ability of a student to letter well depends wholly upon the amount of attention given to the principles underlying the formation of the several styles of letters, and to diligent practice in their construction until nothing short of perfection is attained. The ability of the student to write well or poorly has nothing whatever to do with his proficiency as a good letterer. Good lettering is not mechanical drawing, but is a question of design, or the balancing of black and white masses to produce a pleasing appearance. Some draftsmen insist, however, upon the use of such mechanically distorted letters as geometrical block letters and the shadow letters. These letters are not recommended for use upon any kind of mechanical drawing. Mechanical, structural, and topographical draftsmen are concerned prin-

cipally with the application of modern Roman and Gothic capitals, and the Roman small letters, which make up the descriptive matter and the necessary titles upon their respective type of drawings. The architectural draftsman will not have much use for the modern Roman letters, but will find much use for the old Roman letters.

**History.** Our present day letters are the result of a long evolution in the art of letter formation, leading back to the Egyptians, and coming down to us modified by Phoenician, Greek, and Roman influences. The old Roman style of letters reached their full development about two thousand years ago and are in existence to-day in the form of inscriptions made at that date. This old Roman style is the parent of all present day lettering, and is the one made the most use of by artistic designers at the present time. The capitals were the only letters known up to the beginning of the ninth century, at which time the first Roman small letters were introduced. This first type of small letters was modified during the eleventh century, into the form of the small letters as used to-day.

**Roman Capitals.** The characteristic features of the Roman capital letters consist in the squareness and circularity of their basic forms, and in the use of thin and thick lines in their composition. The use of the thin and thick lines in the formation of these letters, resulted from the manner in which the early Latin scribes held their reed pens in writ-



ing. The pen was held in such a position with respect to the paper, that a downward stroke of the pen, from left to right, gave the maximum width of line, while the downward stroke from right to left gave a very thin line. This feature of the pen-formed letters was later preserved when the letters were cut in stone.

**The Serif** is the horizontal hair-line stroke, used to finish the ends of the stems of all the Roman letters. The serif, in combination with the circular fillets used to join it to the stem, forms the so called spur. The rendering of these spurs exerts a large influence upon the general appearance of the finished letter. It is the usual custom to designate the heavy parts of the Roman capitals as heavy stems, and the thin parts as hair-line stems.

There are numerous variations of the modern Roman capitals extant. The alphabet given on Adams' letter plate 9 is well proportioned and shows a very admirable construction for these letters. The construction of such an alphabet depends essentially upon the height, the relative width, and the weight of the heavy and hair-line stems, and the relation existing between the enclosed white spaces and the black outlines of the letters. These general features are further modified by the different optical effects produced by the various letter forms. If the letters composed of two inclined stems meeting in a point, like the A and V, are made the same height as the other letters, they will appear to be smaller in height than the others. This optical defect can be overcome either by flattening off the sharp intersection to a width equal to that of the heavy stems, or else by extending the pointed end of the letters slightly beyond the height of the other letters, as is done on letter plate 9.

Letters composed of curved portions tangent to the horizontal guide lines, as in the C-G-J-O-Q-S-U, when made equal in height to the others will appear to be smaller in height than

the others. This defect is overcome by extending the top and bottom parts of such letters slightly beyond the horizontal guide lines and thus increasing their height.

Letters composed of two similar halves, as the B-E-R-S-X-Z, must have their top parts decreased both in horizontal and vertical width. This decrease in horizontal width is always made on the right side of the letters mentioned, except in the Z where it is made on the left side. If this difference in the size of the two halves of the letters were not made, they would appear top-heavy. This simple expedient, of making the top portions smaller than the lower portions, gives them an appearance of stability that is pleasing to the eye. This effect of stability is still further enhanced by making the upper spurs of the E-S-Z shorter than the corresponding lower spurs. The appearance of all the letters is also improved by allowing the serifs to extend beyond their points of tangency with the fillets, which join them to the main body of the letters. Especially note the horizontal hair-line in the A-B-E-F-H-P-R and the point of intersection of the diagonal stems in the K-X-Y.

**The Roman Small Letters** did not attain their distinctive proportions until after the invention of printing. Adams' letter plate 11 gives a very good example of this type of letter. It will be noticed that one half of the Roman small letters are merely counterparts of their corresponding capitals. There are three classes of small letters: first those that are equal in height to their corresponding capital letters as the b-d-f-h-l, and known as "ascenders;" second, those that are equal in height to their corresponding capitals but extend below the bottom horizontal guide line of the first class as the g-j-p-q-y, and known as "descenders;" third, those that are only  $\frac{5}{8}$  of the height of their corresponding capitals as the a-c-e-i-m-n-o-r-s-u-v-w-x-z, and known as "short letters." The t, while not as high as its corresponding capital,

belongs to the first class. For optical reasons the curved parts of all the letters, that come tangent to a horizontal guide line, extend a trifle above or below the guide line, as the case may be. The height of the short letters, a-c-etc., as well as the curved parts of the ascenders and descenders, is made equal to  $\frac{5}{8}$  of the height of the ascenders. The stems of the descenders extend, below the lower guide line for the short and ascending letters, a distance equal to  $\frac{3}{8}$  of the height of the ascenders.

**The Gothic Capitals** are an adaptation of the Roman. In their construction, all of the serifs attached to the extremities of the vertical, horizontal, and curved stems of the Roman letters are eliminated, and the weight of all of the stems is made uniform thruout. Adams' letter plate 7, shows the form and construction of the Gothic capitals. Since the thickness of the stems is uniform, their width should not be as great as that of the heavy stems of the Roman capitals. The changes introduced in certain letters of the Roman alphabet, to overcome optical defects, apply with equal force to the corresponding letters of the Gothic alphabet.

**The Gothic Small Letters** are derived from the Roman small letters by eliminating all of the straight and curved serifs and the bulbs and by making the outlines of the letters uniform in weight thruout. They are the simplest form of small letters and for this reason are very largely used for rendering most of the descriptive matter upon drawings. The letters in their simplest form are shown upon Adams' letter plates 18 and 19, lines 12 and 13. In studying the letters as given upon these plates, note the simplification of the a and g and also the difference existing between the g and the q.

**The Circle** is the basic part of the vertical small letters shown upon letter plate 18. This fact should be firmly

fixed in the mind as it will aid greatly in forming the nicely rounded letter, that is so pleasing to the eye in all professional lettering. Also keep this in mind, especially when changing from the vertical type of letters to the inclined type. In the inclined style the circle is changed into an ellipse with its major axis at an angle of 45 degrees, while the straight stems make an angle of between 60 and 75 degrees depending upon the taste of the draftsman.

**The Small Inclined Gothic** is used much more, than is the vertical, for the simple reason that it is easiest to construct rapidly and still preserve its uniform appearance. Any variation in the perpendicularity in the construction of the vertical letters shows up at once and spoils the pleasing effect of the entire line. In the inclined letters, however, there can be considerable variation in the slope of the various letters without its having any serious effect upon the resultant appearance of the finished line of letters. The student needs to practice constantly upon the Gothic small letters until he becomes very proficient in their speedy rendering. Remember that in letters, comparatively small in height, the best effect is obtained by making the letters wide and full in comparison to their height, and also by spacing them close together. The beginner will have to overcome a natural tendency to make the lower end of the curved stem of the h-m-n, slope in towards the bottom of the vertical stem. These stems must be kept parallel to the vertical stems. Their ends may be curved slightly in the opposite direction, in order to obtain the wide effect.

In the composition of the letters, study the order and direction of making the separate strokes for each of the letters, so that it will become a habit to render the strokes in their natural order and direction as given upon the letter plates 18 and 19.

In reading a line of words, the reader unconsciously derives the meaning by a recognition of words forms and not by reading each individual letter in each word. For this reason a line of words composed of small letters is easier to read than if the words are made up of capitals. Care must therefore be exercised to keep the construction of the letters uniform, to space them close together, and to space the words far enough apart to make them easily read. For legibility the words should be spaced a distance apart equal to the height of the letters making up the words. The inclination of the axes of the inclined letters is always forward.

**Numbers.** The essential characteristic of the Roman and Gothic capitals are retained in the construction of their corresponding numbers. The peculiar outline of the numbers requires that their widths be made somewhat smaller than the average width of the corresponding capitals. The numbers, as a general rule, are always made equal in height to the capital letters. Fractions are made somewhat higher, generally twice the height of the whole number preceding. The division line of the fraction is kept horizontal.

---

### STUDY PLATE 1.

**Plate Analysis.** This plate is designed to give practice in:

(a) The development of correct working methods in the use of the detail drawing paper, the white "Normal" paper, and the tracing cloth; in the preparation of the tracing cloth for tracing; in the use of the drawing board and T-square; in the drawing of a horizontal pencil line thru a given point; in the use of the thumb tacks, the

drawing pencil, and the ruling pen; in the ruling of an ink line; in filling the ruling pen; in ruling horizontal lines with either the drawing pencil or ruling pen; in the use of the scale, the pencil and ink erasers, the metal erasing shield and the steel erasing knife; in the lettering of drawings; in the use of the Gillott No. 303 pen, the ball point pen, the stub pen; and the placing of the plate notation.

(b) The placing and aligning of a drawing upon the drawing board, in the placing and the preparation of the tracing cloth, in the tracing of a border line, in the layout of a trimming line, in the layout and drawing of lettering guide lines.

(c) In tracing the elementary strokes as well as the finished letter forms of both the vertical and inclined Gothic capitals, numbers, and small letters, from printed letter plates.

**The Size of the Trimmed Plate** is to be  $10\frac{1}{4}'' \times 14\frac{3}{4}''$ .

**The Plate Requires** a finished tracing to be made of Adams' letter plates 18 and 19.

**The Equipment Required** consists of drawing board, T-square, Architect's scale, large ruling pen, bottle of black drawing ink, pen holder, Leonard No. 521F ball point pen, Gillott No. 303 fine point pen, 2H drawing pencil, pencil sharpener, thumb tacks, pen-wiper, blotter, box of Pounce, Adams' letter plates 18 and 19, and a  $15'' \times 22''$  sheet of tracing cloth.

**Working Methods.** It is particularly important for the student draftsman to give strict attention, at the beginning of his career, to the formation of correct habits in his working methods. He should study the best methods of performing each operation in the construction of a finished drawing, in order to gain speed, accuracy, and neatness as he progresses

in his work. The cost of upkeep for technical service in a drafting room or in any other part of an industrial plant is an expensive proposition under the most favorable conditions. Consequently the man at the head of any particular department, to make a good showing on the right side of the ledger, is compelled to weed out, from his force, the men with inefficient and slipshod methods of working. It is only by the constant repetition of the same thing that habits are formed, hence a piece of work cannot be done in a neat and orderly manner one time and in a slipshod don't-care way the next time without its having its effect in the formation of good habits.

A person, who has formed the habit of doing a thing in a certain way, will unconsciously act according to the habit formed each time he is required to do that particular thing, and it will take a very determined effort on his part to do the thing contrary to the habit that he has formed. In order, for the student to achieve ultimate success in any line of work, he will do well to remember that concentration on the thing to be done and doing it better than it has ever been done before, is the thing that counts most in winning out.

**The Yellow Detail Drawing Paper** is used for making pencil drawings which are to be traced. In making such drawings the preliminary or layout penciling should be done as lightly as possible, consistent with good work. When it is decided, which of the preliminary layout lines are to be incorporated into the final drawing they can be gone over again, with the pencil, and made sharp and black, in order that the drawing may be easily traced. The superfluous lines can then be erased without roughing up the fiber of the paper. Any use of the eraser upon the drawing paper tends to increase its tendency for collecting dirt. Never use a cheap detail paper as it is very poor economy. During the con-

struction of a drawing, exercise care to keep the parts of the drawing, not being worked upon, covered up in order to keep the drawing as clean as possible.

**The White Normal Paper** is used for making pencil drawings which are to be inked. In making such drawings the final, as well as the preliminary penciling, is to be done as lightly as possible, consistent with good work. A very poor ink drawing will be the result of attempting to ink over heavy pencil lines, or heavy lines which have been erased to make them light. Care should be exercised not to draw any extra pencil lines upon this type of drawing, in order that the minimum amount of erasing shall be required to clean the final inked drawing. In cleaning such a drawing, be careful not to rub over the inked lines any more than is absolutely necessary.

**The Tracing Cloth** is used to make inked tracings from pencil drawings, in order that reproductions of them may be made. A pencil drawing, when ready for tracing, must be complete in every detail, with all the pencil lines sharp and black. A great deal of difficulty will be experienced in tracing if the lead pencil lines are too light. After the tracing is completed it is used as a negative to make as many reproductions as required upon a sensitized paper. This paper may be sensitized and manipulated in such a way as to give white lines on a blue back-ground, blue lines on a white back-ground, black lines on a white back-ground, or white lines on a brown back-ground, etc. When a tracing is made, the original drawing may be destroyed because the tracing is filed away for reference and future use.

Tracing cloth is extremely susceptible to moisture, and great care must be exercised in its use. Its transparent qualities will be immediately destroyed whenever water, perspiration, or any other kind of moisture comes into contact with its surface. The condition of the weather has a large influence

on the working qualities of the cloth. A piece of tracing cloth, thoroughly stretched on a dry day, will take ink very readily and be easy to work upon; but if the air should become damp before the tracing is finished, the cloth will become loose on the board, necessitating restretching and destroying the easy working qualities of the cloth. For this reason, when a tracing has once been started it should be hurried to completion as rapidly as possible.

The tracing cloth is prepared for receiving ink, by first tightly stretching it with its dull side uppermost. A small quantity of the Pounce is then sprinkled over the cloth and thoroughly rubbed into the surface with the fingers. After the rubbing process is over, the excess Pounce must be thoroughly dusted off, otherwise difficulty will be experienced in inking.

**The Drawing Board** is to be placed on the drawing table with its long edges facing the student. The best face, and the best of the short edges of the board should have a pencil mark placed upon them, in order that they may be the ones always used for drawing purposes. The short edge of the board, as marked, should be at the student's left when the board is placed upon the drawing table. With the drawing board in the proper position for drawing, print your name in the upper right hand corner. Do not use the marked face of the board for anything but drawing purposes. In case it is desired to use the board for trimming plates, the back face of the board is to be used, so as not to damage the drawing face in any way.

**The T-square** is used for drawing parallel horizontal lines. It is placed upon the drawing board, Fig. 59, in such a position that its long part or blade lies flat upon the drawing face of the board, and the short part, or head rests against the left hand short edge of the board. The T-square is manipulated, Fig. 59, by grasping its head in the left hand. It is

extremely important that care be exercised to always hold the head of the T-square tightly against the edge of the board, in order that a line drawn with the square in one position will be exactly parallel to every other line drawn with the square in other positions. The top edge of the T-square blade is used for drawing lines, Fig. 60, and as a rest for the triangle, Fig. 61. Never use this edge of the blade as a straight edge to trim drawings, but always use the lower edge of the blade for this purpose. Be careful to keep the top

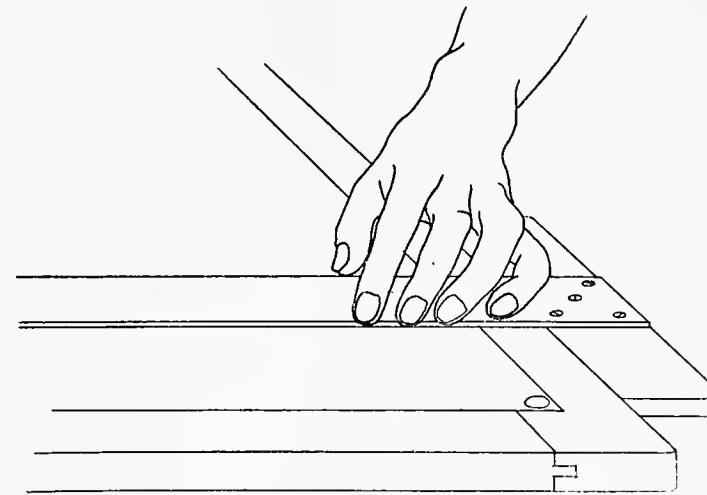

Fig. 59.—Front View—Showing Manipulation of T-square.

edge of the blade free from nicks, otherwise inaccuracy in the drawing will result. Never use a square whose blade is not perfectly straight and firmly attached to the head. In pencil drawings, the T-square is used only for drawing horizontal lines. It is never used for drawing vertical lines because the long edges of the drawing board cannot be depended upon as being at right angles to the left hand edge of the board. In tracing, however, the T-square can be used as

a straight edge for the inking of any straight line, whether horizontal, vertical, or diagonal. In using the T-square as a straight edge, keep its head away from the edges of the board, and make the top edge of the blade coincide with the line to be inked.

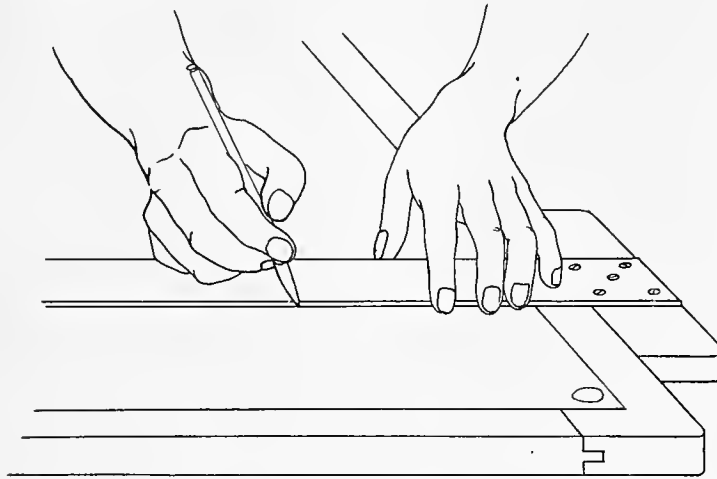

Fig. 60.—Front View—Ruling a Horizontal Pencil Line.

**To Draw a Horizontal Pencil Line Thru a Given Point,** Fig. 60, move the blade of the T-square until its top edge exactly coincides with the given point. With the T-square head held tightly against the left hand edge of the drawing board, and with the drawing pencil inclined slightly away from the body so as to bring its point close against the under side of the ruling edge of the blade, Fig. 61, proceed to draw the line, by moving the pencil away from the head of the T-square and inclining it slightly in the direction of motion. Never draw a horizontal line by moving the pencil towards the head of the T-square. In using the T-square as a straight edge for ruling pencil or ink lines, always draw along the blade from left to right. To trace a pencil line in ink, Figs. 66 and 67, the ruling edge of the

blade of the T-square must be kept away from the pencil line about  $\frac{1}{32}$  of an inch and parallel to it, Fig. 62. This is necessary in order to hold the ruling pen in the correct position, and also to prevent the edge of the T-square from coming in contact with the freshly inked line. Practice in the manipulation of the T-square until it becomes second nature to do it correctly.

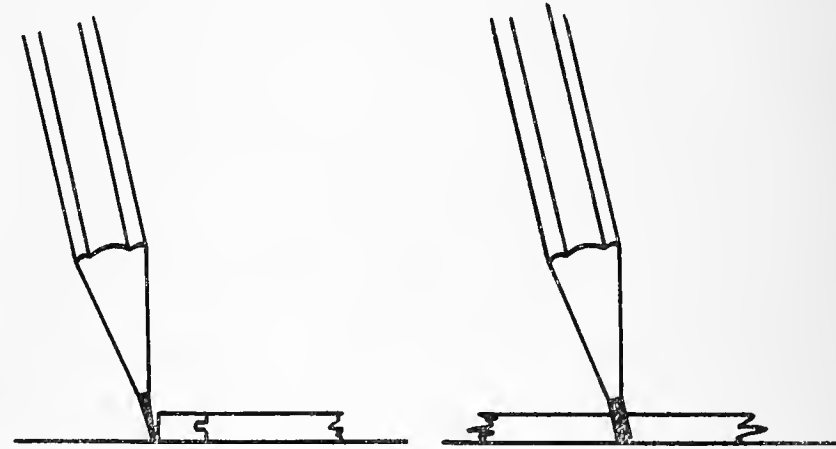

Fig. 61.—Correct Position of Pencil when Ruling a Line.

**The Drawing Pencil** is prepared for use by cutting back the wood from the end of the pencil, so as to leave about  $\frac{3}{8}$  of an inch of lead projecting Fig. 63. Do not cut the lead with the knife. It is customary to sharpen each end of the pencil, bringing one end to a round sharp conical point, and the other to a flat sharp chisel point. The Conical point, Fig. 64, is used for lettering and laying off distances. The chisel point, Fig. 65, is used for drawing. Sharpening both ends of the pencil will destroy the mark showing the hardness of the pencil. However, this difficulty may be overcome by cutting notches in the middle of the pencil to show whether the pencil is 2H, 5H, or some other grade. The chisel point has the advantage over the conical point for

ruling lines, in that its edge keeps sharp much longer than does the conical point when used for this purpose. A dull pencil indicates a lazy draftsman and should not be toler-

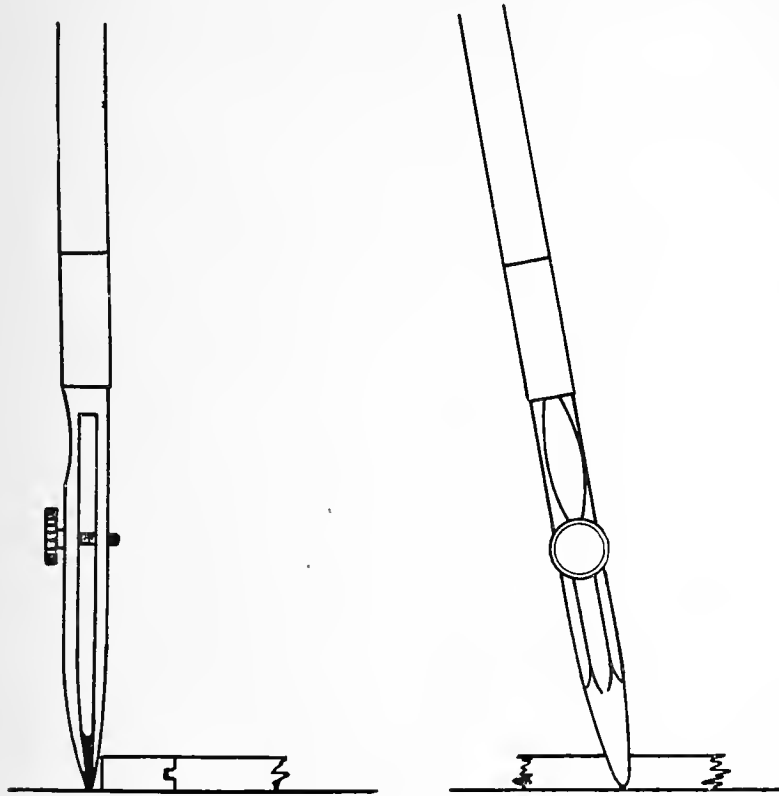

Fig. 62.—Correct Position of the Ruling Pen when Ruling a Line.

ated. Do not bear down upon the pencil in ruling a line, as this will cut a groove in the paper, which will be impossible to erase.

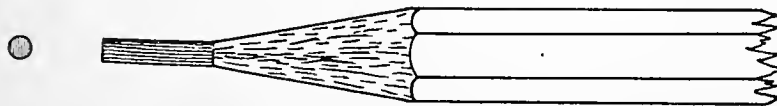

Fig. 63.—Preparation of Lead.

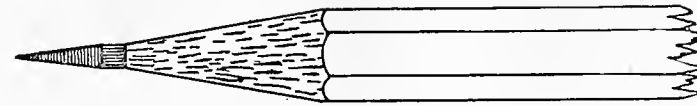

Fig. 64.—Conical Point.

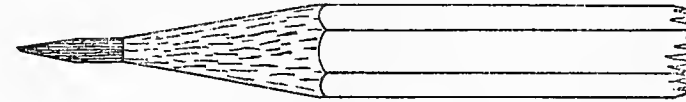

Fig. 65.—Chisel Point.

**Thumb Tacks** are used to attach the drawing paper and tracing cloth to the drawing board. For small sheets one tack is usually placed in each of the four corners, while for large sheets, extra tacks will have to be placed along their edges. Insert the thumb tacks so that their heads will come down tight against the board. A tack which is inserted with only a part of the head touching the board, will prove a source of annoyance to the careful draftsman. It will also catch against the working edge of the T-square blade and do considerable damage to it.

**The Ruling Pen** is probably the most used instrument of all, and for this reason must be of the best quality. Its correct manipulation requires considerable practice. The pen is held in the hand in a similar manner to that used for holding the drawing pencil. The set screw on the pen, Fig. 66, is held turned away from the body. The tip of the forefinger rests on the outside blade of the pen, just touching the set screw. The thumb and second finger rest in a natural position on the inner blade. None of the fingers should be cramped or



stiff, but should be kept as straight as possible. In ruling an inked line, Fig. 66-67, the axis of the pen should be kept perpendicular to the paper, with the rear blade in contact

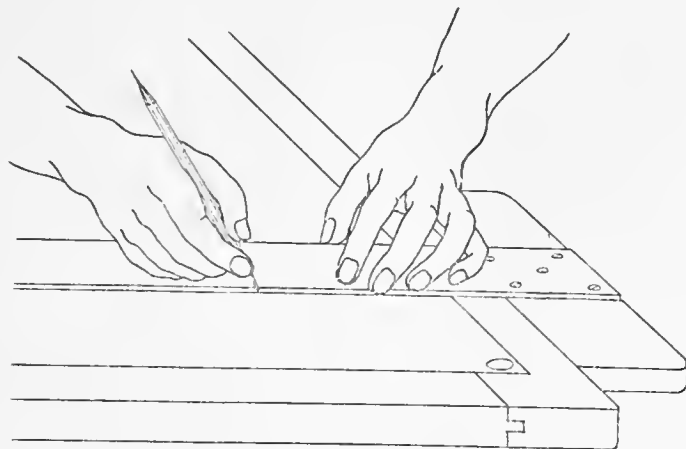

Fig. 66.—Front View—Ruling an Ink Line.

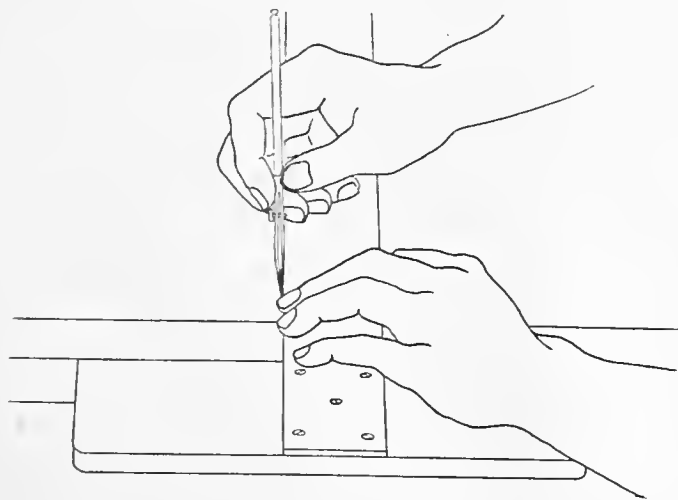

Fig. 67.—End View—Ruling an Ink Line.

with the straight edge. This position will throw both nibs of the pen into contact with the surface of the paper, and

at the same time, keep them away from the under side of the straight edge, Fig. 62. Always start the pen moving just as soon as it touches the tracing cloth, and keep it moving with the top of the pen inclined slightly in the direction in which the line is being drawn. Just before the end of the line is reached, the pen should be brought perpendicular to the cloth, and when the end of the line is reached it should be lifted from the cloth at once.

Always look ahead in drawing a line either with the pencil or the drawing pen. Be sure to fix in mind the location of the end of the line, and in this way prepare yourself to stop the pen as the line is finished. It is very poor form on the draftsman's part to start or stop a line at any other place than the exact end. In starting or stopping a line, whose ends touch another line, which has been inked, great care must be taken to make the intersection of the two lines sharp and distinct. At the junction of two lines, always move the pen without hesitation in order to avoid a blot at their intersection. Do not allow the pen to be stationary a single instant upon the tracing cloth in starting or stopping an ink line. If this precaution is not followed, a blot will be the result.

Never attempt to draw any line with the nibs of the pen tightly closed together. The thickness or thinness of the ink line is always determined by the opening between the nibs of the pen, provided that the pen is sharp, that the outside of the points are scrupulously clean, and that no dried ink has been allowed to accumulate on the inside of the nibs. In setting a pen to draw a certain width of line always test it by actually drawing a line on a separate piece of paper before using it on the drawing proper. In order to obtain the original setting of the pen after it has been opened for cleaning, while in use, it is extremely important to follow this precaution. A drawing which shows a non-uniformity in



the widths of similar lines, shows a lack of care with respect to this precaution. Do not bear down upon the pen in ruling a line.

**In Filling** the pen, do not dip it into the ink bottle, but use the quill attached to the bottle stopper to transfer the ink from bottle to pen. Place the end of the ink quill between the blades of the pen and allow the ink to run from the body of the quill into the pen. Do not fill the pen to more than  $\frac{1}{4}$ " in height for ordinary work, Fig. 63, until you become expert in its use. In drawing long lines, the pen should contain enough ink so that the entire line may be drawn without refilling. If the pen runs dry before the end of the line is reached, refill and by starting back along the part of the line already inked, taking care to follow it exactly a junction can be made that cannot be detected.

Each time the pen is laid aside, and occasionally while the pen is in use, a blotter should be run between the nibs to remove all the ink which may be left in the pen. Also after refilling the pen, and before starting to use it, rub off any ink which may have collected on the outside of the nibs. When thru using the pen, it should be immediately and thoroughly cleaned, inside and out.

**In Ruling Horizontal Lines** with either the drawing pencil or ruling pen, the lines should always be drawn from left to right. In ruling vertical lines the pencil or ruling pen should draw the line by moving away from the body of the draftsman, and never towards him. In ruling diagonal lines, if the line is inclined upwards to the right, when starting at the lower end, the drawing pen or pencil must move upward along the proposed line and away from the body. If the line slopes upward to the left, the line should be drawn by making the drawing pencil or pen move downward along the proposed line and towards the body. In the actual ruling of a line do not rest the entire hand upon the

straight edge but allow only the ends of the third and fourth fingers to slide lightly along the surface of the straight edge. Careful attention to this point will go a long way towards acquiring a command of the drawing pen and pencil.

**The Scale** is used only for laying off distances which may be done either by laying the scale on the drawing and pointing off the required distance with a sharp round pointed pencil, or prick punch, Fig. 68, or by holding the scale in the left hand and taking off the required distances with the dividers held in the other hand, Fig. 69. The first method will be treated here and the other later on. In laying off dimensions with the scale, by laying it upon the drawing and

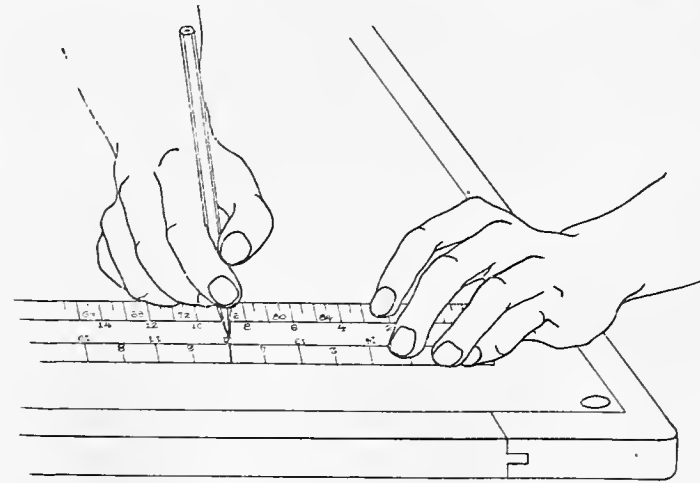

Fig. 68.—Front View—Taking off Scale Dimensions with Pencil.

pointing off the required distances, Fig. 68, always endeavor to point off as many dimensions as possible without changing the position of the scale. At the required scale division make a dot on the paper with a conical pointed pencil. In doing this always keep the axis of the pencil in line with the division line on the scale, and allow the point of the pencil to follow down the division groove until it comes into contact with the paper. Do not make a hole in the paper, or a

larger dot than is necessary to be plainly visible. It is difficult to draw a line accurately thru the center of holes and large dots. For the present, the twelve inch scale as divided into 1-16 inches, will be the only one used. By the use of the eye these divisions can be further subdivided into

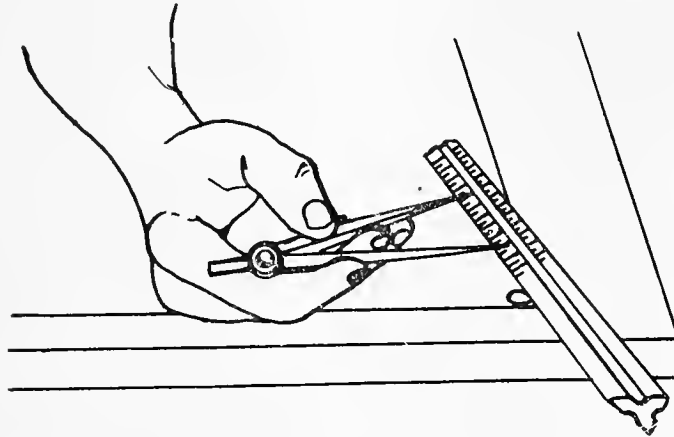

Fig. 69.—Front View—Taking off Scale Dimensions with Dividers.

1-32nds and 1-64ths of an inch. In laying off distances, be careful to lay down the exact distance and not something pretty close to it. Accuracy at this point in the drawing will save an immense amount of trouble in working upon complicated drawings. Do not use the scale as a straight edge for drawing lines.

**The Pencil and Ink Erasers** are valuable adjuncts to the draftsman's outfit. The draftsman, however, needs to be careful in their use, as otherwise he will get into a careless way of drawing, knowing that the wrong or unnecessary lines can be easily erased. A draftsman with the erasing habit loses time on nearly every line he draws. The

careful draftsman will have very little use for either kind of eraser, because he realizes that speed is not the result of erasing lines after they are once drawn. The use of an eraser on a drawing always increases the capacity of the drawing for collecting dirt. Hence in penciling a drawing, the lines which have to be erased, should be put in as lightly as possible. In using the ink eraser on the tracing cloth,

**Be Careful Not to Rub a Hole Thru the Cloth.** If a blot is formed upon the cloth at any time, do not attempt to blot it up by laying a blotter down upon it; but with one corner of the blotter pick up as much of the wet ink as possible, without bringing the blotter into contact with the cloth, and then allow the rest to dry. Be sure that the blot is dry before starting to erase. If the blot is by itself and plenty of room is available, proceed to erase the ink with a circular ink eraser. When the ink is removed rub the erased surface of the cloth with the back of the finger nail or a piece of soapstone to a good polish. Then rub a little Pounce into it. By the use of these precautions, the surface of the cloth can be brought to its original ink taking qualities.

**The Erasing Shield** is used in case it is necessary to erase a line, or a blot, located in a complicated part of the drawing. In using the shield, it is placed so that one of the holes provided in its surface comes over the part to be erased, while the rest of the shield protects the parts of the drawing immediately surrounding the part to be erased.

**The Steel Erasing Knife** is never used except in extreme cases. Great care must be exercised in its use, otherwise irreparable damage will be done to the drawing.

**The Lettering** upon a drawing consists of the main title for the drawing, the sub-titles for each part, the dimension figures, arrow heads, feet and inch marks, finish marks,

and all special notation and descriptive matter necessary to supplement the picture of the object as drawn. These various kinds of lettering require different styles of lettering pens for their correct rendering.

**The Gillott No. 303**, or fine pointed pen, is best for rendering the descriptive matter, dimension figures, feet and inch marks, finish marks, etc.

**The Ball Point Pen**, F, Leonard No. 521F, is best for rendering the main and sub-titles.

As some difficulty is experienced at times in breaking in a new fine pointed pen to do good work, the student should provide himself with a collection of pens of several kinds and sizes. He will then have a wide range from which to choose a pen which is just right. STUB PENS are not recommended, as it takes an expert to turn out good lettering with them. In manipulating the lettering pen do not bear down upon it, as this not only causes a varying width in the letter outline, but also causes the pen to dig into the surface of the drawing. In lettering always hold the penholder between the thumb and first finger. Keep the first finger straight and do not grip the penholder any tighter than is actually necessary to guide the pen. Do not rest any more of the hand on the surface of the drawing than is absolutely necessary.

The chief essential in good lettering is a whole arm movement rather than a finger and wrist movement. Always hold the pen in the same position when drawing horizontal, vertical, inclined, or curved strokes. Do not try to letter with too much ink upon the pen. When using the lettering pen, clean it frequently with a soft cloth, at the same time work the nibs back and forth to get the dried particles of ink out from between them. The student should practice with the lettering pen to secure an easy natural position of the body,

arm, and hand, as when such a position is once acquired one of the chief difficulties in turning out good lettering has been overcome.

**The Plate Notation**, Fig. 70, is to appear upon all study plates in exact accordance with the layout shown. The following course abbreviations are to be used:-

Agricultural (all courses) .....	Agr.
Architectural .....	Arch.
Chemistry .....	Chm.
Civil (all courses) .....	C. E.
Electrical .....	E. E.
Electrochemical .....	Echm.
Industrial Chemistry .....	I. Chm.
Industrial Engineering (all courses).....	I. E.
Mechanical (all courses) .....	M. E.
Mining (all courses) .....	M. M.
Physics .....	Phy.

Use vertical Gothic capitals for the plate number, and inclined Gothic capitals for the rest of the plate notation.

### Schedule of Operations.

#### Placing and Aligning the Drawing.

1. Place Adams' letter plate 18 upon the drawing board so that the long sides of the plate are parallel to the long edges of the board and the top and left hand edges of the plate are about one inch from the corresponding edges of the board and approximately parallel to them.

2. Insert a thumb tack in the center of the left hand edge of the plate as close to the edge of the plate as possible.

3. With the head of the T-square held tightly against the left hand edge of the drawing board adjust both the T-square and plate until some horizontal line upon the plate coincides with the top edge of the T-square.

TRIMMING LINE

BORDER LINE

PLATE NUMBER

PLATE

2 1/2"

KIND OF PLATE.	STOCK SIZE OF SHEET.	TRIMMED SIZE OF SHEET.	BORDER LINE DIMENSIONS.	MARGIN.
FULL SIZE DRAWING.	15 x 22	13 3/4 x 19 3/4	12 x 18	7/8
HALF .. ..	11 x 15	10 3/4 x 13 3/4	9 x 12	7/8
LETTER PLATES.	11 x 15	10 1/4 x 14 3/4	9 x 13 1/2	5/8

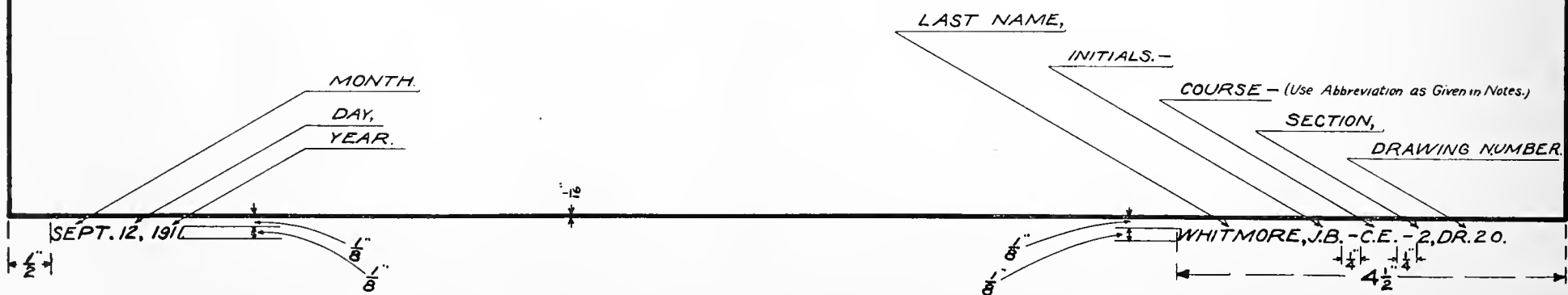

Fig. 70.—Plate Notation.

4. Insert a thumb tack in the center of the right hand edge of the plate as close to the edge as possible.

#### Placing and Preparing the Tracing Cloth.

5. Double a 15" x 22" sheet of tracing cloth together so that its short edges coincide. Smooth out the fold and slit the cloth along the same with a sharp pen knife. Keep one of the small 11" x 15" sheets out for use and put the other away.

6. Place the 11" x 15" sheet of tracing cloth over the letter plate. Keep the dull side uppermost and see that there is an equal margin of cloth outside of the border line all around. Keep the edges of the cloth parallel to this border line.

7. Insert a thumb tack in each of the four corners of the cloth. In inserting the tack, keep the point within  $\frac{1}{8}$  of an inch of the edge of the cloth. Be sure that the cloth is tightly stretched over the surface of the plate.

8. Sprinkle a small quantity of the Pounce over the surface of the cloth. Rub it in well and then brush off all of the excess.

**Border Line.** Follow the layout sheet, Fig. 71, as the remaining operations are performed.

9. Set the ruling pen to draw a line nearly 1-16" wide. Fill it with a  $\frac{1}{4}$ " column of back drawing ink. Practice drawing lines with it upon a separate piece of tracing cloth or drawing paper so as to become acquainted with its peculiarities.

10. With the drawing pen set and inked as in (9), with the head of the T-square held against the left hand edge of the drawing board and with the top edge of its blade parallel to and 1-32 of an inch below the top border line of the letter plate, proceed to ink the line upon the cloth. Start and stop the line exactly at each of its respective ends.

11. Allow the line just inked to dry. Then proceed to rule in the lower border line in the same manner.

12. Allow the line just inked to dry. Then proceed to ink the right hand border line. In doing this do not place the head of the T-square against the bottom edge of the board, but use the T-square blade as a straight edge, keeping it parallel to and 1-32 of an inch away from the line to be inked. Be very careful about starting and stopping the line, in order that its ends may neither fall short of, nor run past the ends of the two ink lines previously drawn. The ends of the lines should just touch in order to form a neat corner in the border line.

13. Repeat (12) for the left hand border line.

14. Clean the pen and put it away.

#### Trimming Line.

15. Using the scale and 2H pencil lay off a distance of  $\frac{5}{8}$ " from each end of the left hand border line. This distance is to be laid off at right angles to the border line and towards the outside edge of the sheet.

16. Proceed in a similar manner for the remaining three parts of the border line.

17. With the T-square and 2H pencil proceed to rule a light line the entire length of the sheet and thru the points laid off to the left of the left hand border line.

18. Proceed in a similar manner, to draw light pencil lines the entire length of the sheet thru the remaining respective pairs of points.

#### Drawing Lettering Guide Lines.

19. Using the edge of the scale, which is divided into 1-16ths of an inch, place its zero mark over the top border line and make the working edge of the scale coincide with the left hand border line of the plate.

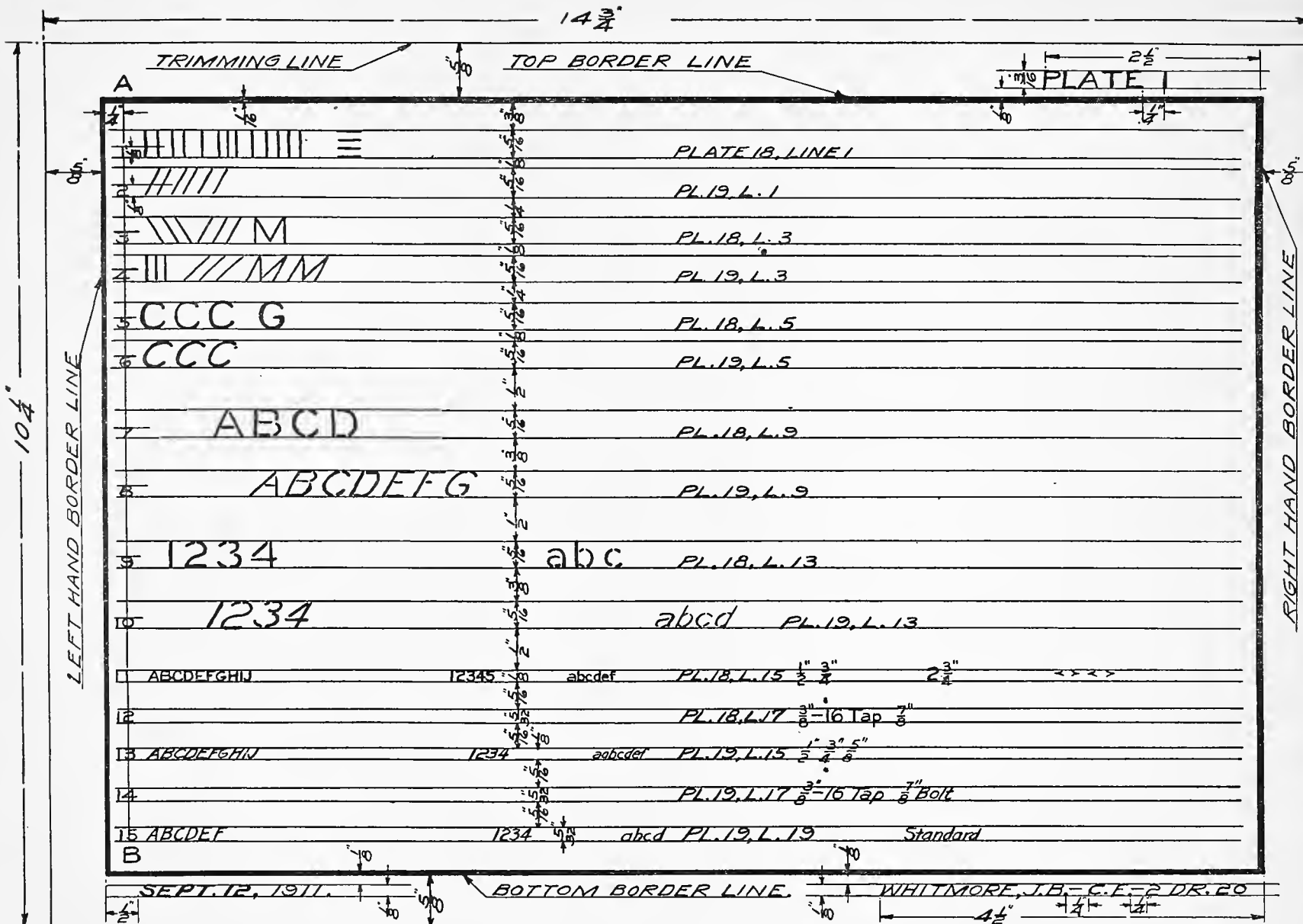

Fig. 71.—Layout Sheet for Study Plate 1.

20. Using a 2H conical pointed pencil, proceed to point off the distances called for on the layout sheet, Fig. 71, for the spacing of the horizontal guide lines shown thereon. Work from the top border line down, and do not move the scale until all of the distances have been pointed off. Make light pencil dots upon the tracing cloth to indicate the several distances.

21. With the T-square and the 2H chisel edged pencil, proceed to draw light horizontal guide lines thru each of the points of division. Do not extend the pencil lines beyond the end border lines of the plate.

22. With the scale and 2H pencil measure in  $\frac{1}{4}$ " from each end of the left hand border line, and draw lightly the vertical line A-B.

23. With the scale and 2H pencil measure up along this line a distance of  $\frac{1}{8}$ " from its point of intersection with each of the bottom horizontal guide lines, of each guide line set.

24. With the T-square and 2H pencil draw a light horizontal guide line about  $\frac{1}{4}$  of an inch long thru each of these points of division to extend  $\frac{1}{8}$ " on each side of the vertical line A-B.

25. With the ball point pen and black drawing ink, proceed to number each of the guide line sets as called for upon the layout sheet, Fig. 71. Make the last figure of each number fall upon the vertical line A-B. Be careful to keep each of the figures within the horizontal guide lines that were drawn to limit their heights. Follow line 12 of the letter plate underneath the tracing cloth for the actual drawing of the figures.

#### Tracing Adams' Letter Plate 18.

26. Remove the thumb tacks from the tracing cloth. Do not disturb the position of the letter plate. Move the tracing cloth to make the first set of horizontal guide lines on the

tracing cloth coincide with the imaginary horizontal guide lines of line No. "1," on letter plate 18. At the same time keep the left and right hand border lines on the tracing exactly over the corresponding border lines on the letter plate. In order to keep the tracing cloth in its proper place, place a thumb tack in each of its four corners. Keep the tack holes outside of the pencil trimming line. This procedure is to be followed each time a new line is to be traced from the letter plate underneath, upon the tracing cloth.

27. With the ball point pen proceed to trace in the first line of letter plate 18.

28. See (26) and trace line "3" of letter plate 18, into guide line set "3" on the tracing cloth.

29. See (26) and trace line "5" of letter plate 18, into guide line set "5" on the tracing cloth.

30. See (26) and trace line "9" of letter plate 18, into guide line set "7" on the tracing cloth. Do not trace the arrows which show the direction of the strokes, nor the figures which show the order in which the strokes are to be made. Do not join the strokes of the letters together but leave them as shown on the letter plate.

31. See (26 and 30) and trace line "13" of letter plate 18, into guide line set "9" on the tracing cloth.

32. See (26) and trace line "15" of letter plate 18, into guide line set "11" on the tracing cloth. Use Gillott No. 303 pen for this and also for (33).

33. See (26) and trace line "17" of letter plate 18, into guide line set "12" on the tracing cloth.

#### Tracing Adams' Letter Plate 19.

34. Remove the thumb tacks from both the tracing and the letter plate. See (1, 2, 3, 4) and attach Adams' letter plate 19 to the drawing board.

35. See (26) and trace line "1" of letter plate 19 into guide line set "2" on the tracing cloth. Use ball point pen.

36. See (26) and trace line "3" of letter plate 19 into guide line set "4" on the tracing cloth.

37. See (26) and trace line "5" of letter plate 19 into guide line set "6" on the tracing.

38. See (26 and 30) and trace line "9" of letter plate 19 into guide line set "8" on the tracing.

39. See (26 and 30) and trace line "13" of letter plate 19 into guide line set "10" on the tracing.

40. See (26) and trace line "15" of letter plate 19 into guide line set "13" on the tracing. Use Gillott No. 303 pen for (40, 41, and 42).

41. See (26) and trace line "17" of letter plate 19 into guide line set "14" on the tracing.

42. See (26) and trace line 19 of letter plate 19 into guide line set "15" on the tracing.

#### Plate Notation.

43. Using the scale and 2H conical pointed pencil measure down  $\frac{1}{8}$ " and  $\frac{1}{4}$ " respectively from the lower border line of the plate. See Figs. 70 and 71 for the plate notation.

44. Using the T-square and 2H chisel edged pencil, draw two light, horizontal guide lines the entire length of the plate.

45. Using the scale and 2H conical pointed pencil, lay off along these guide lines a distance of  $\frac{1}{2}$ " and 9", starting in each case from the lower, left hand corner of the plate border line. In the right hand corner of the plate, measure up from the top border line  $\frac{1}{8}$ " and 5-16" respectively.

46. Using the T-square and 2H chisel edged pencil, draw two light guide lines to extend 3" to the left, starting above the upper right hand corner of the border line.

47. Measure in a distance of  $2\frac{1}{2}$ " along these guide lines, starting from the point in (46).

48. With the ball point pen and drawing ink, proceed to render the word "PLATE 1" in vertical Gothic capital letters. Start at the point laid off in (47).

49. With the Gillott No. 303 pen and drawing ink, start from the  $\frac{1}{2}$ " distance, laid off on the two lower guide lines, and render the month, day, and year that the plate is finished, in inclined Gothic capital letters. This date is always that upon which the plate is due, as stated upon the posted work schedules.

50. Starting from the 9" distance, render the last name, initials, course abbreviation, section number, and catalogue number of the course in inclined Gothic capital letters. With the pencil eraser, erase the pencil guide lines used in the lettering of the plate notation.

51. Remove the thumb tacks from the tracing and letter plate. Trim the tracing cloth along the pencil trimming line drawn in (15, 16, 17 and 18). The trimmed tracing should measure  $10\frac{1}{4}$ " wide by  $14\frac{3}{4}$ " long. **HAND THE TRACING TO YOUR INSTRUCTOR PROMPTLY WHEN IT IS CALLED FOR AND DO NOT ROLL OR FOLD IT.**

---

#### STUDY PLATE 2.

**Plate Analysis.** This plate is designed to give practice in the rendering in ink upon drawing paper, of the elementary strokes of the vertical Gothic capitals, numbers, and small letters, in the combining of these elementary strokes in a certain numerical order to render the completed letter forms; in the rendering of arrow heads, feet and inch marks, and in the use of both fine and ball point pens.



**The Size of the Finished Plate** is to be 11" x 15½".

**The Plate Requires** an inked rendering of Adams' Letter Plate 18.

**The Equipment Required**, consists of drawing board, T-square, pen-holder, ball-point pen, fine point pen, bottle of ink, pen wiper, thumb tacks, architect's scale, 2H pencil, sand paper pad, pencil eraser, ink eraser, blotter and Adams' Letter plate 18.

### Schedule of Operations.

#### Placing and Aligning the Letter Plate.

1. Place Adams' letter plate 18 on the drawing board so that the long sides of the plate are parallel to the long edges of the board, and the top and left hand edges of the plate are about 1" from the corresponding edges of the board and approximately parallel to them. Insert a thumb tack in the upper left hand corner of the plate.

2. With the head of the T-square held tightly against the left hand edge of the drawing board, adjust both the T-square and the plate until some horizontal line upon the plate coincides with the top edge of the T-square.

3. Insert a thumb tack in each of the remaining corners of the letter plate.

#### Plate Notation.

4. Using the scale and 2H conical pointed pencil, measure down ¼" and ⅜" respectively from the lower border line of the plate. See Fig. 70 for the plate notation.

5. Using the T-square and 2H chisel edged pencil, draw two light horizontal guide lines the entire length of the plate.

6. Using the scale and 2H conical pointed pencil, lay off along these guide lines a distance of ½" and 9", starting in each case from the lower left hand corner of the plate border line.

7. Using the T-square and 2H chisel edged pencil, draw two light guide lines to project 1" to the right of the end of the plate number, as given at the top of the plate, and make these lines correspond to the imaginary guide lines of the word "Plate," as printed there.

8. Measure a distance of ¼" to the right of the figure "8," and using the ball point lettering pen and drawing ink, print in a vertical figure 2.

9. Using a Gillott No. 303 lettering pen and drawing ink, and starting from the ½" distance laid off on the two lower pencil guide lines, print in the month, day, and the year that the plate is finished, in inclined capital letters. This date is always that upon which the plate is due, as posted upon the work schedules.

10. Starting from the 9" distance, print in the last name, initials, abbreviation for course, section number and catalogue number of the course, in inclined capital letters. With the pencil eraser, erase the guide lines used in lettering; the plate notation.

#### Ink Rendering.

11. With the ball point pen and drawing ink proceed to ink line 2 of the letter plate to correspond to line 1.

12. Ink line 4 to correspond to line 3.

13. Ink line 6 to correspond to line 5.

14. Ink line 10 to correspond to line 8, using line 9 as a guide to indicate the direction and the order of inking the elementary strokes for each letter.

15. Ink line 14 to correspond to line 12, using line 13 as a guide to indicate the direction and the order of inking the elementary strokes for each letter.

16. Using the Gillott No. 303 pen and drawing ink, proceed to ink line 16 to correspond to line 15.

17. Ink line 17 to correspond to the first half of line 15.

18. Ink line 18 to correspond to the first half of line 15 and the last half of line 17.

19. With a pencil eraser, clean off the pencil guide lines and remove the thumb tacks.

20. HAND THE PLATE PROMPTLY TO YOUR INSTRUCTOR WHEN CALLED FOR, AND DO NOT ROLL OR FOLD IT.

---

### STUDY PLATE 3.

**Plate Analysis.** This plate is designed to give practice in the rendering in ink upon drawing paper of the elementary strokes of the inclined Gothic capitals, numbers, and small letters; in the combining of these elementary strokes in a certain numerical order, in order to render the completed letter forms; in the rendering of arrow heads, feet and inch marks, and in the use of both the fine and ball point pens.

**Size of the Finished Plate** is to be 11" x 15½".

**The Plate Requires** an inked rendering of Adams' letter plate 19.

**The Equipment Required** consists of drawing board, T-square, pen-holder, ball point pen, fine point pen, bottle of black drawing ink, pen wiper, thumb tacks, Adams' letter plate 19, architect's scale 2H pencil, sand paper pad, pencil eraser, ink eraser, and blotter.

**Schedule of Operations.**

1—7. For steps from 1 to 7 inclusive, follow the corresponding steps in the outline for study plate 2.

8. Measure a distance of ¼" to the right of the figure 9, and, using the ball point lettering pen and drawing ink, print in a vertical figure 3.

9—18. For steps from 9 to 18 inclusive, follow the corresponding steps in the outline for study plate 2.

19. Ink line 20 to correspond to line 19.

20—21. For steps 20 and 21 follow the corresponding steps in the outline for study plate 2.

---

### STUDY PLATE 4.

**Plate Analysis.** This plate is designed to give practice in:

(a) The development of correct working methods in the use of the triangles, in the drawing of a vertical line of a given length thru a given point, in the drawing of a vertical line with its lower end resting upon a previously drawn horizontal line, in the preliminary suggestion of large letters as an essential part of their complete rendering, in the suggestion of a letter drawn freehand, in the study of the fundamental masses of letters, and in the mechanical spacing of suggested letters.

(b) The placing and aligning of drawing paper, the layout of a pencil trimming line, the layout of a pencil border line, the inking of a pencil border line upon the drawing paper, the layout and ink rendering of the plate notation, the layout and drawing of horizontal pencil lettering guide lines, the construction of a mechanical spacing scale for lettering, the mechanical spacing of letters preliminary to their construction, and the drawing of both vertical and inclined letter spacing guide lines.

(c) The Pencil Suggestion of vertical Gothic capitals, numbers, and small letters; of inclined Gothic capitals, numbers, and small letters; of vertical Roman capitals, numbers, and small letters; and of inclined Roman capitals, numbers, and small letters.

(d) The completion of the suggested letters and their subsequent rendering in ink.

**The Size of the Finished Plate** is to be  $10\frac{1}{4}'' \times 14\frac{3}{4}''$ , when trimmed.

**The Plate Requires** a pencil and inked rendering to be made upon white normal paper from Adams' letter plates 4 and 5.

**The Equipment Required** consists of drawing board, sheet of  $15'' \times 22''$  white normal paper, thumb tacks, architect's scale, 2H pencil, ruling pen, bottle of ink, ball point pen fine point pen, pen holder, pen wiper, blotter, pencil sharpener, pencil eraser, 30 x 60 degree triangle, and one each of Adams' letter plates 4, 5, 7, 9, and 11.

#### Working Methods.

**The Triangles** are used in conjunction with the T-square for drawing all vertical pencil lines and most of the vertical ink lines upon a drawing or tracing. It is very essential that ease in the manipulation of the T-square—triangle combination be acquired as soon as possible, Fig. 72.

In using the triangle to draw vertical lines, Fig. 73, one of the edges which forms the right angle of the triangle,—usually the short one with the 30 x 60 degree triangle,—is always placed in contact with the top edge of the T-square blade. The rule which requires that all vertical lines be drawn upward and away from the body of the draftsman and never downward towards his body, makes it necessary to keep the vertical edge of the triangle always facing the head of the T-square. If the triangle is not placed with its verti-

cal edge facing the T-square head, but instead facing towards the right hand edge of the drawing board, the vertical line

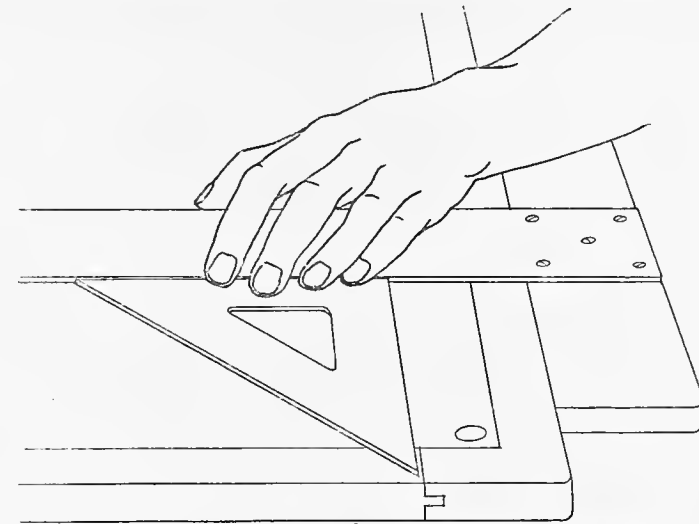

Fig. 72.—Front View—T-square Triangle Combination.

can be drawn only in a downward direction which is not only undesirable, but also very awkward. Never use the triangle in contact with the lower edge of the T-square blade.

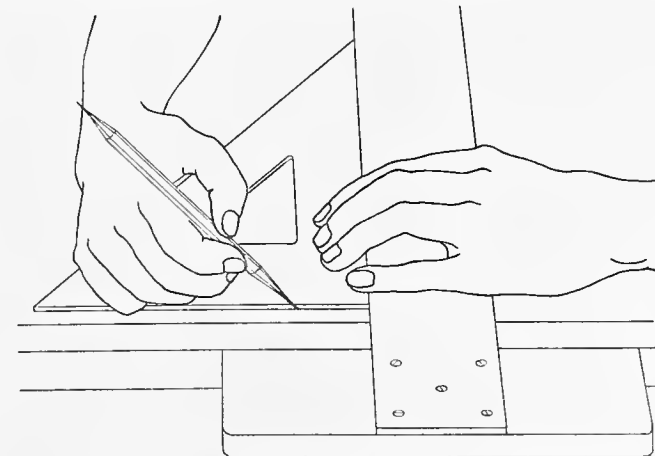

Fig. 73.—End View—Drawing Vertical Line.

**To Draw a Vertical Line of a Given Length Thru a Given Point, Fig. 73,** first place the ruling edge of the T-square a short distance from the lower end of the proposed line but never to intersect it, so that when the triangle is in position with one of its edges in contact with the ruling edge of the T-square, the other, or vertical edge, will coincide with as much of the line as possible. Second, place the triangle with the longest of its edges in a vertical position and exactly coinciding with the centre line of the point through which the line is to be drawn, at the same time keeping the horizontal edge of the triangle, in contact with the ruling edge of the T-square. With the left hand grasp both the T-square blade and the triangle as shown, keeping the head of the T-square tight against the edge of the drawing board and the lower edge of the triangle tight against the blade of the T-square.

With the pencil in the right hand, proceed to draw the required line, by always keeping the point of the pencil close against the vertical edge of the triangle, moving it away from the blade of the T-square and never towards it.

**To Draw a Vertical Line Which Shall Start From a Given Horizontal Line, Fig. 73,** first, place the ruling edge of the T-square a short distance below the horizontal line but never to coincide with it; second, place the triangle in the position described for drawing a vertical line thru a point and proceed to draw a line.

**Preliminary Suggestion of Large Size Letters as an Essential Part of the Complete Rendering.** The fundamental principle for success in any kind of freehand drawing requires that the main outline of the object be sketched in before attempting to render any part of the details and also that in sketching in the main outlines, no attempt be made to draw them full at first, but to suggest parts of the line and repeat the process until the entire line can be drawn in at a single stroke. The details are

suggested in a similar manner until finally they can be rendered in their entirety. These same principles apply with equal force to large freehand lettering.

**To Suggest a Large Freehand Letter,** as shown on Adams' letter plate 4, lines 5, 6, 13 and 14 and plate 5, lines 3, 7, 11, and 18, it is first necessary to draw two horizontal pencil guide lines to limit the top and bottom extremities of the letter. The width of the letter is then laid off upon these horizontal guide lines, usually with the eye and without the use of mechanical aids. Thru the points which were laid off to indicate the letter width, short vertical guide lines are drawn, to intersect the top and bottom horizontal guide lines. Both horizontal and vertical guide lines are to be drawn mechanically using the T-square and triangle. After the guide lines are drawn, the principal features of the outside outlines of the letter are suggested in pencil, then the thickness of the stems of the letter is indicated, by a partial suggestion of the inside outline. After the suggested letter has been corrected, the suggested parts of the outline are connected and completely rendered. The suggested portions of the inside outline of the letter are connected in the same manner and the inside outline completely rendered. When the outlines have been completely rendered, the space between the outlines is filled in and the letter completed as a whole.

**The Fundamental Masses** of the letters as shown on letter plate 4, lines 3, 4, 11, 12 and letter plate 5, lines 2, 6, 10 and 17 must be firmly fixed in the mind, otherwise the various letters cannot be successfully suggested. The formation of the letters from their elementary masses is shown on letter plate 4, lines 7, 8, 15 and 16, and letter plate 5, lines 4, 8, 12 and 19. These various lines should be carefully studied in detail by the student before he attempts to suggest any of the letters.

The Spacing of the Suggested Letters is largely a matter of judgment in the equalizing of the white spaces between adjacent letters with the black fundamental masses of the letters themselves. Hence the added importance of intimate knowledge of the fundamental mass of each of the letters.

### Schedule of Operations.

#### Placing and Aligning Drawing Paper.

1. Fold a 15" x 22" sheet of white "Normal" paper so that its 15" edges coincide. Smooth the fold and slit with a sharp knife. Keep one of the 11" x 15" sheets out for use and put the other away. Place the 11" x 15" sheet of drawing paper upon the drawing board, so that the long sides of the plate are parallel to the long edges of the board and the top and left hand edges of the plate are about one inch from the corresponding edges of the board and approximately parallel to them. Insert a thumb tack in each corner of the plate, keeping the point of the tack within 1-8" of the edges of the sheet.

#### Drawing Trimming Line.

2. With the T-square and 2H chisel edge pencil, draw a light horizontal line the entire length of the plate within  $\frac{1}{4}$ " of its top edge. See layout sheet, Fig. 74.

3. With the T-square, 30 x 60 degree triangle and 2H pencil, draw a light vertical line the entire width of the plate and within 1-8" of its left hand edge.

4. Using the edge of the scale which is divided into 1-16ths, with its zero mark, placed at the point of intersection of the top and left hand trimming lines drawn in (2) and (3), proceed to lay off a distance of  $14\frac{3}{4}$ " along the top trimming line and  $10\frac{1}{4}$ " along the left hand trimming line.

5. With the T-square and 2H pencil, draw a light, horizontal line the entire length of the plate, thru the last point laid off in (4).

6. With the T-square, 30x60 degree triangle and 2H pencil, draw a light vertical trimming line the entire width of the plate thru the first point laid off in (4). If the trimming lines, as drawn, do not fall entirely upon the plate, place the plate so that they will and redraw them.

#### Drawing Border Line.

7. With the scale and 2H pencil, measure in a distance of  $\frac{5}{8}$ " from and perpendicular to each of the four trimming lines just drawn.

8. With the T-square and 2H chisel edged pencil, draw light horizontal lines thru each of the points laid off perpendicular to the top and bottom trimming lines respectively. Start and stop these lines within 1-2" of each of the end trimming lines.

9. With the T-square, 30x60 degree triangle, and 2H chisel edged pencil, draw light vertical lines thru each of the points laid off perpendicular to the end trimming lines. Start and stop these lines upon the bottom and top horizontal lines drawn in (8).

#### Inking Border Line.

10. Using the T-square and with the ruling pen set for a line 1-16" wide and filled with black drawing ink, proceed to ink the top border line. Start and stop the line exactly upon the two pencil border lines at each end of the plate.

11. In like manner ink in the lower border line.

12. Using the T-square as a straight edge, with its head adjacent to the lower edge of the drawing board, but not touching it, proceed to ink in the right hand border line. Start and stop the line exactly at the respective ends of the horizontal border lines previously inked, in order to make the corners sharp.

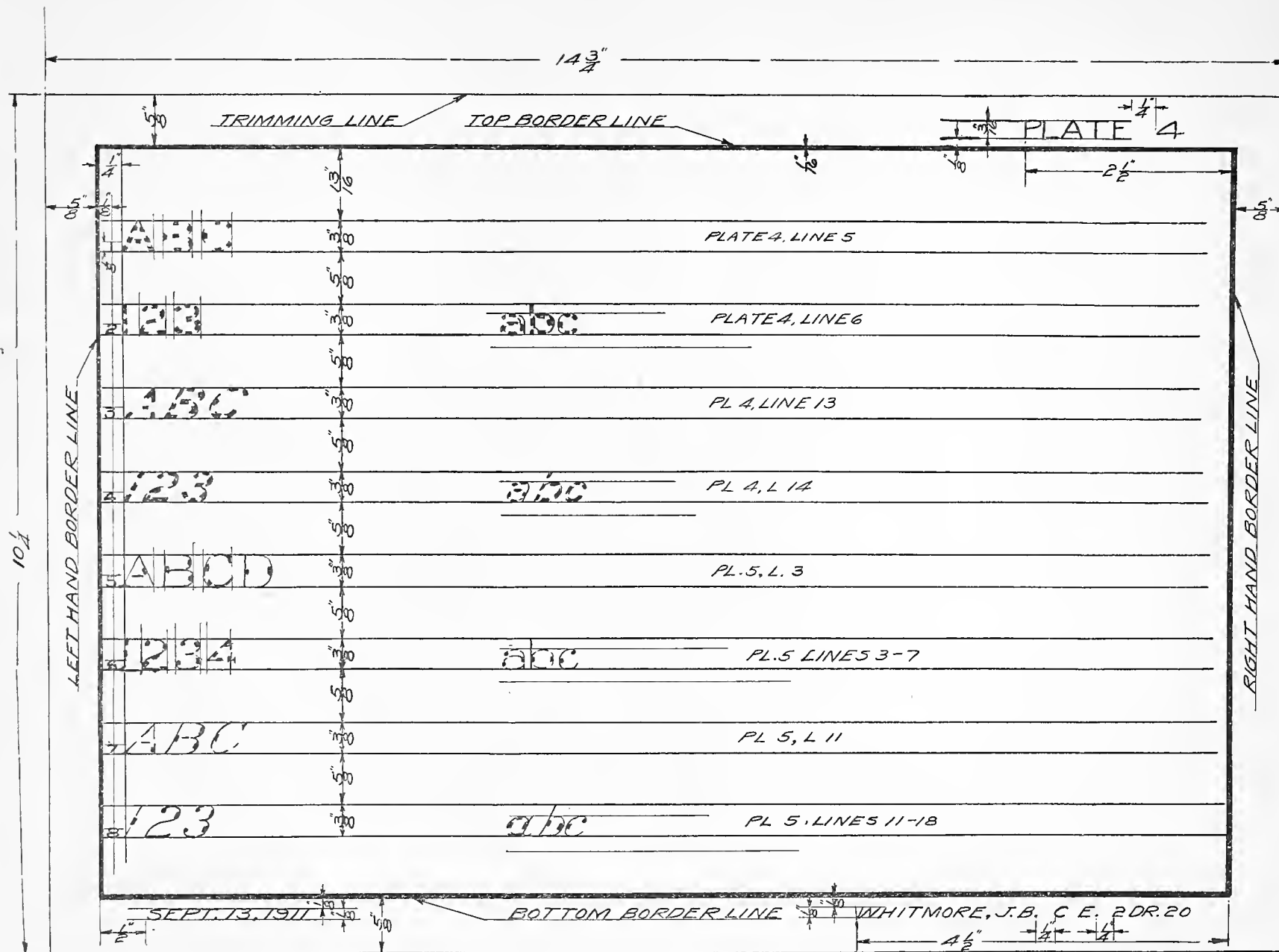

Fig. 74.—Layout Sheet for Study Plate 4.

13. In like manner ink in the left hand border line.
14. Clean the pen and put it away.

#### Plate Notation.

15. With scale, 2H pencil and T-square, proceed to draw in the horizontal guide lines in the top and bottom margins of the plate for the plate notation. Follow the layout sheet, Fig. 74.

16. With the ball point pen, ink in the plate number, which is "4."

17. With the Gillott 303 pen, ink in the due date of the plate, the name, etc.

#### Drawing Horizontal Pencil Guide Lines For Lettering.

18. Using the 2H conical pointed pencil and with the zero of the scale placed over the upper left hand corner of the border line, point off along the left hand border line the dimensions given on the layout sheet, Fig. 74, for the spacing of the horizontal lettering guide lines. Work from the top of the sheet downward and point off as many divisions as possible without moving the scale. Exercise care to get the divisions exactly as called for.

19. Using the T-square and the pencil with a sharp chisel edge, proceed to draw thru these several points of division, light horizontal guide lines the full length of the sheet, as included between the two vertical lines forming part of the border line.

20. With the scale, measure in 1-8" from the left hand border line and draw a light vertical line to intersect all of the horizontal guide lines drawn.

21. Measure up along this vertical line from its point of intersection with the bottom line of each guide line set a distance of  $\frac{1}{8}$ ".

22. With the T-square and pencil, draw a light horizontal line  $\frac{1}{4}$ " long thru each of these points, starting the line in each case at the left hand border line.

23. With the conical pointed pencil, print in the number of each guide line set from 1 to 8 inclusive. The top guide line set is to be numbered 1. Use vertical figures and keep their axes upon the vertical line drawn in (20) and their top and bottom parts in contact with the guide lines drawn in (22) and the bottom horizontal guide line of each guide line set. This will make the figures 1-8" in height.

24. With the scale, measure in  $\frac{1}{4}$ " from the left border line and draw a light vertical line to intersect all the horizontal guide lines. Use the T-square and 30x60 degree triangle to do this. This line represents the starting point for each line of letters.

#### Construction of Mechanical Spacing Scale.

25. Upon the edge of a separate, small piece of drawing paper, measure off the exact distance,  $\frac{3}{8}$ ", which is equal to the height of the proposed letters. With a sharp pencil, proceed to divide this distance as laid off, into 8 equal parts, or units.

#### Mechanical Spacing of Letters Preliminary to Their Construction.

26. The figures given under each letter and each space between two adjacent letters on Adams' letter plate 7, lines 1 and 2 represent the number of units which must be laid off to give the width of the letter or of the space.

27. Starting from the vertical line, as drawn in (24), lay off in succession along the bottom horizontal guide line of guide line set 1, the distances representing the widths of the letters and the spaces between them, as given for the Gothic alphabet of capital letters on Adams' letter plate 7, lines 1 and 2. Use the paper scale of (25) to measure these distances.



Thus with the zero of the scale over the vertical line drawn in (24), lay off 8 units, or the whole length of the scale, to represent the width of the "A", then move the scale along until its zero point is over the last point laid off, and lay off  $2\frac{3}{4}$  units of the scale to represent the space between the A and the B. From this point, lay off 7 units to represent the width of the "B" and proceed in the same way for the remaining letters of the alphabet up to and including the "Z", but not the "&". These distances will have to be laid off in an accurate manner, as otherwise the line of letters will project beyond the right hand border line of the plate, in which case the line must be respaced until it does come wholly within the end border lines without touching them.

28. With the T-square, 30-60 triangle, and chisel edged pencil, draw a short, light, vertical guide line thru each of these points of division to intersect both the top and bottom horizontal guide lines of each of the guide line sets 1 and 5. At the same time draw a line not more than 1-16" long to intersect the bottom horizontal guide line of each of the guide line sets 3 and 7. Use the triangle so that each time the vertical guide line is drawn for guide line set 1, the short vertical guide line, and the two short intersection lines can be drawn for the guide line sets 5-3-7 respectively. To do this, it will be necessary to place the short side of the triangle in contact with the T-square, leaving the long side available for drawing the vertical lines.

29. Starting from the vertical line again, lay off in succession along the bottom horizontal guide line of guide line set 2, the distances representing the widths of the Gothic numbers from 1 to 0 inclusive and the spaces between them, as given on Adams' letter plate 7, line 2. Use the paper scale to measure the distances in an accurate manner. At the end of the "0", space  $2\frac{1}{4}$  units to the right and follow this by the

width of the "&" as given in line 2, letter plate 7. Then space 8 units more to the right.

30. Starting from the last point laid off in (29), lay off in succession along the bottom guide line of guide line set 2, the distances representing the spacing of the center lines of the Roman small letters from "a" to "z" inclusive, as given in line 1, Adams' letter plate 11. If the line runs beyond right hand border line, respace until it does not.

31. With the T-square, 30-60 triangle, and chisel edged pencil, draw a short, light, vertical line thru each of these points of division, to intersect both the top and bottom horizontal guide lines of each of the guide line sets 2 and 6. At the same time draw a line not more than 1-16" long to intersect the bottom horizontal guide line of the guide line sets 4 and 8. Use the triangle so that each time the vertical guide line is drawn for guide line set 2, the short vertical guide line and the two short intersection lines can be drawn for the guide line sets 6-4-8 respectively.

32. Below both the top and bottom horizontal guide line of guide line sets 2-4-6-8, lay off three of the paper scale divisions.

33. With the T-square and pencil, draw light horizontal guide lines thru these points. These lines are to extend only the length of the small letter alphabet as previously laid off, and are not to extend under that part of the guide lines drawn for the number.

34. With the T-square, 30-60 triangle and pencil, proceed to draw thru the points of division indicated upon the bottom horizontal guide line, of guide line sets 3, 4, 7, and 8, light guide lines inclined at an angle of  $60^\circ$  with the horizontal guide lines, and to intersect the extreme top and bottom horizontal guide line of each set. In drawing the inclined lines, place the short  $90^\circ$  edge of the triangle in contact with the



ruling edge of the T-square so that the inclined edge of the triangle will face the head of the T-square. This position of the triangle will admit of the inclined guide lines being drawn upwards from left to right, which is the desired direction.

#### **Pencil Suggestion of Vertical Gothic Letters and Numbers.**

35. Using Adams' letter plate 4 as a model, and with the pencil sharpened to a conical point, proceed to construct in guide line set 1, the suggested vertical Gothic capitals as given on Adams' letter plate 4, line 5. The horizontal top and bottom, and the vertical spacing guide lines are the only mechanically drawn lines that are to be used. The suggestion of the alphabet is to be done free hand in order to train the hand and eye and also to fix clearly in the mind the characteristic features of each letter. Pay particular attention to the primary black masses of the letters as given in line 3 of the letter plate, and also to the way in which the letter 'i' is formed from its primary mass as shown in line 7.

36. In guide line set 2, suggest the vertical Gothic numbers and small letters as given on Adams' letter plate 4, line 6. Note especially the primary masses, line 8. Include the suggested form of the "&" in its proper space.

#### **Pencil Suggestion of Inclined Gothic Letters and Numbers.**

37. In guide line set 3, suggest the inclined Gothic capitals as given on Adams' letter plate 4, line 13. Pay particular attention to the primary masses and to the development of the letters from their primary masses, lines 11 and 15 respectively.

38. In guide line set 4 suggest the inclined Gothic numbers and small letters as given on Adams' letter plate 4, line 14. Include the suggested form of the "&" in its proper space. Note especially the primary masses and the develop-

ment of the letters from their primary masses, lines 12 and 16 respectively.

#### **Pencil Suggestion of Vertical Roman Letters and Numerals.**

39. In guide line set 5, suggest the vertical Roman capitals as given in line 3 letter plate 5, from A to Z inclusive. See letter plate 9 for the relation existing between the Roman letters and their vertical guide lines.

40. In guide line set 6, suggest the vertical Roman numbers from 1 to & inclusive, followed by the small letters as given in lines 3 and 7 respectively, of letter plate 5.

#### **Pencil Suggestion of Inclined Roman Letters and Numbers.**

41. In guide line set 7, suggest the inclined Roman capitals from A to Z inclusive as given in line 11 letter plate 5.

42. In guide line set 8, suggest the inclined Roman numbers from 1 to & inclusive, line 11, followed by the small letters as given in line 18 of letter plate 5.

#### **Ink Rendering of Suggested Letters.**

43. Using the Gillott 303 pen and drawing ink, completely render in ink the letters A-D-I-M-Q-U-Y in guide line set 1, as given in line 1, letter plate 4.

44. Completely render in ink, the numbers and letters 1-5-9-b-f-j-n-r-v-z in guide line set 2, as given in line 2 letter plate 4.

45. Completely render, in ink, the letters B-F-J-N-R-V-Z in guide line set 3, as given in line 9 letter plate 4.

46. Completely render in ink, the numbers and letters 2-6-0-c-g-k-o-s-w in guide line set 4, as given in line 10, letter plate 4.

47. Completely render in ink, the letters C-G-K-O-S-W in guide line set 5, as given in line 1, letter plate 5.

48. Completely render in ink, the numbers and letters 3-7-&-d-h-l-p-t-x in guide line set 6, as given in lines 1 and 5 respectively, of letter plate 5.

49. Completely render in ink, the letters D-H-L-P-T-X in guide line set 7, as given in line 9, letter plate 5.

50. Completely render in ink, the numbers and letters 4-8-a-e-i-m-q-u-y in guide line set 8, as given in lines 9 and 15 respectively, of letter plate 5.

51. With the pencil eraser, clean off all pencil lines in the margin of the plate, between the border and trimming lines. Do not erase any of the construction lines inside of the border line.

52. Remove the thumb tacks from the plate. Trim it with a sharp knife along the trimming line by using the back of the drawing board to cut upon, and the lower edge of the T-square blade as a guiding edge for the knife in following the pencil trimming line of the plate. **HAND THE PLATE PROMPTLY TO YOUR INSTRUCTOR WHEN CALLED FOR AND DO NOT ROLL OR FOLD.**

---

### SPACING OF LETTERS.

The spacing of the letters in the alphabet is as much a problem in artistic design as is the construction of the letters themselves. In the construction of the letters the relations that exist between their height and width and between their black outlines and the enclosed white spaces must be so proportioned as not to cause any particular letter to stand out any more prominently than the rest. In the actual construction of an alphabet of letters, not only must the above relations be correctly balanced, but also the relation that exists between the black outlines of each two adjacent letters and the white space enclosed between them. This is necessary in order to

make the alphabet, when viewed as a whole, present a uniform and pleasing appearance to the eye.

The same principle holds true in the formation of letters into words, and of words into sentences, with the added requirement that the resulting combination can be easily read without eye fatigue.

There are three methods of spacing: first, the equal area method; second, the equal space method; and third, a combination of the two.

The **Equal Area Method** of spacing letters, requires that the white space enclosed between the black outline of two adjacent letters must be equal to a similar area enclosed between any other two adjacent letters of the alphabet or word as the case may be. In the use of this method, difficulties are encountered in the spacing of the A-F-J-L-T-V-W-X-Y-Z with the other letters of the alphabet.

The **Equal Space Method** of spacing letters requires that equal spaces be kept between the extreme projections of two adjacent letters. The same difficulty is experienced in the use of this method as was experienced in the use of the equal area method, as it gives good results only for certain letter combinations. However, this method does correct some of the difficulties experienced in the use of the first method, and therefore indicates that a combination of the two methods will give better results than the exclusive use of either one.

The **Combination of the Equal Area With the Equal Space** method of spacing letters, gives excellent results in a majority of the letter combinations, but at the same time it cannot be laid down as a hard and fast rule. Those peculiar letter combinations to which the above rules do not apply must be spaced so that they will present a harmonious appearance with the remainder of the letters composing the particular word in which they occur. It is very essen-

tial for the draftsman to study the forms of the various letters and practice to become proficient in their spacing by eye rather than by the use of mechanical aids. In spacing letters it is the tendency of the beginner to make the spaces between his letters too large. A much better appearance will result from a close spacing.

### Mechanical Spacing.

The **Mechanical Spacing** of letters is often desirable. Especially is this the case in the construction of titles and also in the construction of a line of words that is to fit into a certain specified distance.

In devising a system of mechanical spacing it is necessary to keep in mind the fundamental principles underlying the construction and the spacing of the letters, in order to make the system available for general use. Obviously a mechanical spacing system which applies to a particular style of alphabet, will not apply to a different style. The mechanical method must in every instance give as good results in practice as the expert draftsman is able to obtain without its use. The task of devising such a system can be appreciated when it is remembered that the 26 letters of the alphabet give 676 possible letter combinations each of which must be actually tested out in order to render the system of any practical use.

The mechanical spacing tables I, II, and III, are given for use in the spacing of the Roman capitals, small letters and numbers, as shown upon Adams' letter plates 9 and 11. Tables IV and V are given for use in the spacing of the Gothic numbers and capitals as shown upon Adams' letter plate 7.

The **Standard of Comparison** used upon the above letter plates for the detailed construction of the letters is

also used as the standard of reference for the spacing tables. This standard of reference, as previously mentioned, is the height of the letter, or the vertical distance included between the horizontal guide lines which limit the top and bottom parts of the letters. In order to make the standard really serviceable, it is necessary to divide it into a number of equal parts, just as it is necessary to divide an inch into 1-8ths, 1-16ths, etc. As our most familiar unit of measure is the inch, the division of the lettering standard into equal parts is made to conform to its characteristic divisions. The standard is therefore divided into eight equal parts. One of these equal parts, that is 1-8th of the height of the letters, is taken as the **PRINCIPAL UNIT OF MEASURE** instead of the entire height of the letters. All dimensions required in the actual construction of the letters are given both upon the letter plates and in the mechanical spacing tables, as whole or fractional parts of the **PRINCIPAL UNIT OF MEASURE**.

**In Spacing Roman Capitals, Followed by Small Letters,** use the spacing distances as given in table VI. The method of using the mechanical spacing tables is taken up under the working methods for study plate 5, and also in the paragraph on the use of the tables as given in connection with them.

### The Use of the Mechanical Spacing Tables.

The first table of the two given under Tables I and V together with Tables II, III, IV, and VI, shows the spacing distances between adjacent letters and numbers, as shown upon Adams' letter plates 7, 9, and 11. In using these tables to find the proper spacing distances between two letters or numbers, look in the vertical column at the left of the table for the first of the two letters or numbers, and across the top of the table for the second. Find where the horizontal line con-

Letters	A	BDE FHIK LMN PRU	CG OQ S	J	T	V	W	X	Y	Z
A	$1\frac{1}{4}$	$2\frac{3}{4}$	2	$\frac{3}{4}$	0	$\frac{3}{8}$	$\frac{3}{4}$	$1\frac{1}{4}$	$\frac{1}{4}$	$1\frac{1}{2}$
BDGR	$2\frac{1}{4}$	$3\frac{1}{4}$	$2\frac{1}{2}$	$1\frac{1}{2}$	$1\frac{1}{4}$	$2\frac{1}{4}$	$2\frac{3}{4}$	$1\frac{1}{2}$	$\frac{3}{4}$	$1\frac{3}{4}$
CEOQS	2	3	$2\frac{1}{4}$	$1\frac{1}{4}$	1	2	$2\frac{1}{2}$	1	$\frac{1}{2}$	2
H I J M N U	$2\frac{3}{4}$	4	3	2	$2\frac{1}{4}$	$2\frac{3}{4}$	$3\frac{1}{4}$	$3\frac{1}{2}$	$2\frac{3}{4}$	$2\frac{3}{4}$
K	$1\frac{1}{4}$	$2\frac{5}{8}$	2	$\frac{3}{4}$	$\frac{3}{8}$	1	$1\frac{1}{4}$	$1\frac{1}{4}$	$\frac{1}{2}$	1
L	$1\frac{1}{4}$	$1\frac{1}{2}$	$\frac{1}{2}$	$\frac{1}{2}$	$-\frac{1}{4}$	$-\frac{1}{4}$	$\frac{3}{8}$	$1\frac{1}{4}$	$-\frac{3}{8}$	$\frac{1}{2}$
P	$\frac{3}{8}$	$2\frac{1}{2}$	$1\frac{3}{4}$	0	$\frac{1}{2}$	$1\frac{1}{2}$	2	$\frac{1}{2}$	$\frac{1}{4}$	$1\frac{1}{2}$
FT	0	$2\frac{1}{4}$	1	$-\frac{1}{4}$	$\frac{1}{2}$	$\frac{1}{2}$	$1\frac{1}{4}$	$1\frac{1}{4}$	$1\frac{1}{4}$	$\frac{1}{2}$
V	$\frac{3}{8}$	$2\frac{3}{4}$	2	0	$1\frac{1}{4}$	$1\frac{1}{4}$	$2\frac{1}{4}$	$1\frac{1}{4}$	$1\frac{1}{4}$	$1\frac{1}{4}$
W	$\frac{3}{4}$	$3\frac{1}{4}$	$2\frac{1}{2}$	$\frac{3}{8}$	$1\frac{1}{4}$	$2\frac{1}{4}$	3	2	$1\frac{1}{4}$	2
X	$1\frac{1}{4}$	$3\frac{1}{2}$	2	$\frac{3}{4}$	$1\frac{1}{4}$	$1\frac{1}{4}$	2	$1\frac{1}{2}$	1	1
Y	$-\frac{1}{4}$	$2\frac{3}{4}$	$1\frac{1}{2}$	0	$1\frac{1}{4}$	$1\frac{1}{4}$	$1\frac{1}{4}$	$1\frac{1}{4}$	$1\frac{1}{4}$	1
Z	$1\frac{1}{2}$	$2\frac{3}{4}$	2	$\frac{3}{4}$	$\frac{1}{2}$	$1\frac{1}{4}$	2	1	1	$\frac{1}{4}$

Letter Widths For Letters on ADAMS' LETTER PL9			
A	8	N	7
B	7	O	$7\frac{1}{2}$
C	$7\frac{1}{2}$	P	7
D	7	Q	$7\frac{1}{2}$
E	$7\frac{5}{8}$	R	7
F	$7\frac{3}{8}$	S	7
G	$7\frac{1}{2}$	T	$8\frac{3}{4}$
H	7	U	7
I	$1\frac{1}{4}$	V	8
J	$5\frac{1}{2}$	W	$10\frac{1}{2}$
K	7	X	8
L	7	Y	8
M	$9\frac{3}{8}$	Z	7

Table I  
Mechanical Spacing Table for Roman Capital Letters.  
\*See "Use of the Mechanical Spacing Tables".

LETTERING—MECHANICAL SPACING TABLES

Letters	ac de oq s	bfh km np ru	g	il	j	t	v w x y z
a	$7\frac{1}{4}$	8	$7\frac{1}{4}$	$5\frac{1}{2}$	$4\frac{1}{4}$	$6\frac{1}{4}$	7
beops	$6\frac{1}{2}$	$7\frac{1}{4}$	$6\frac{3}{4}$	$4\frac{3}{4}$	4	$6\frac{1}{4}$	$6\frac{1}{4}$
c	6	$6\frac{3}{4}$	$6\frac{1}{4}$	$4\frac{1}{4}$	$3\frac{1}{2}$	$5\frac{3}{4}$	$5\frac{3}{4}$
dqu	$7\frac{1}{4}$	$8\frac{1}{4}$	$7\frac{1}{2}$	$5\frac{3}{4}$	$4\frac{3}{8}$	$6\frac{3}{4}$	7
*f	$4\frac{1}{8}$	* $4\frac{1}{2}$	$4\frac{3}{8}$	$2\frac{1}{4}$	$\frac{1}{4}$	$3\frac{3}{8}$	$4\frac{1}{8}$
g	$7\frac{1}{8}$	$7\frac{7}{8}$	$7\frac{3}{8}$	$5\frac{3}{8}$	$4\frac{3}{4}$	$6\frac{1}{2}$	$6\frac{1}{2}$
*hmn	7	$7\frac{5}{8}$	$7\frac{1}{4}$	$5\frac{1}{8}$	$4\frac{1}{8}$	$6\frac{1}{2}$	$6\frac{3}{4}$
*i	5	6	$5\frac{3}{8}$	3	$1\frac{7}{8}$	4	$4\frac{3}{8}$
*j	7	$7\frac{7}{8}$	$7\frac{1}{4}$	$5\frac{1}{8}$	$4\frac{3}{8}$	6	$6\frac{1}{2}$
k	$6\frac{7}{8}$	$7\frac{5}{8}$	$7\frac{1}{8}$	$5\frac{1}{8}$	4	$6\frac{1}{4}$	$7\frac{1}{4}$
r	6	$6\frac{3}{4}$	$6\frac{1}{4}$	$4\frac{1}{4}$	$2\frac{1}{2}$	$4\frac{5}{8}$	$5\frac{1}{2}$
*t	4	* $5\frac{1}{4}$	$4\frac{1}{2}$	3	$1\frac{1}{2}$	4	4
vwxYZ	$6\frac{1}{4}$	7	$6\frac{1}{2}$	$4\frac{3}{8}$	3	$5\frac{5}{8}$	$7\frac{1}{4}$

Table II  
Mechanical Spacing for Roman Small Letters.  
\*For Exceptions See "Use of the Mechanical Spacing Tables".

taining the first of the two letters or numbers intersects the vertical column containing the second. The number given at their intersection, shows the distance in units that the two letters or numbers must be spaced apart. The second of the tables under Tables I and V gives the number which represents the widths of the letters.

The unit for spacing and for the widths of the letters is taken as 1-8 of the height of the letters. The numbers given in the tables and the dimensions given upon Adams' letter plates 7, 9, and 11 are given as whole or fractional parts of this unit.

The spacing dimensions taken from Tables I, III, IV, and V show the distance in units that the vertical guide lines, for adjacent Roman and Gothic capitals and numbers, (see Adams' letter plates 7 and 9), are to be spaced apart in order to give the proper spacing between adjacent letters and numbers.

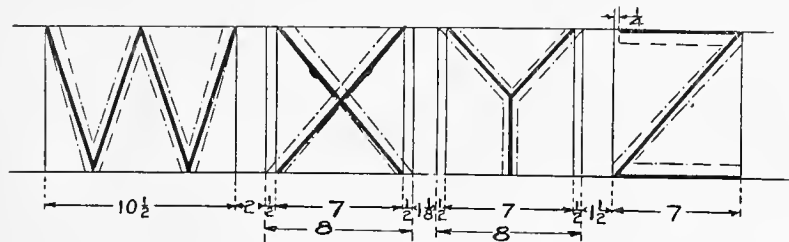

Fig. 75.—Modified Spacing Guides for X and Y.

The spacing dimensions taken from Table II show the distance in units that the vertical centre lines, for the Roman small letters (see Adams' letter plate 11) are to be spaced apart in order to give the proper spacing between two adjacent letters.

The spacing dimensions taken from Table VI show the distance in units that the vertical centre line of a Roman small letter must be spaced from the vertical guide line of the preceding Roman capital to give the proper spacing between the two letters.

In spacing the Gothic and Roman X and Y in letter combinations, the vertical spacing guides for these two letters are to be moved out and drawn thru the extreme horizontal projections of the letters, Fig. 75, instead of as shown upon Adams' letter plates 7 and 9.

The numbers given in the spacing tables for these two letters, together with the numbers given in the second of the tables, under Tables I and V for the widths of these letters, are based upon this change.

In spacing the Roman small letters, f-g-j-m-t-w and z, the spacing guides are to be taken as shown in Fig. 76, in place of the way shown on Adams' letter plate 11. The Roman small "i" and "l" are to be spaced according to their vertical centre lines in place of the way shown upon letter plate 11. In spacing the Roman small "w" and "m" in letter combinations, the distance between either and a preceding letter is measured from the centre line of the preceding letter to the centre line drawn thru the first half of these letters; while the spacing distance of a letter following either of these letters is measured from the centre line of the last half of these letters to the centre line of the following letter. In spacing the Roman small "u" after the "t", make the centre line distance between the two equal to  $4\frac{3}{4}$ . In spacing the Roman small "f", when followed by m, n, p, r or u, make the



Fig. 76.—Modified Center Line Spacing Guides for the Roman Small Letters Shown.

LETTERING—MECHANICAL SPACING TABLES

Numerals	Width of Numerals AD.LT.PL.9.	AD.LT.PL.9.					
		1	2-3	4	5	6-8 9-0	7
1	$4\frac{3}{4}$	$4\frac{1}{8}$	$3\frac{1}{2}$	2	3	$3\frac{5}{8}$	2
2	$6\frac{1}{2}$	$3\frac{3}{8}$	$1\frac{7}{8}$	$1\frac{3}{8}$	2	$2\frac{1}{8}$	$\frac{7}{8}$
4	6	$4\frac{1}{8}$	$2\frac{7}{8}$	3	3	3	2
5	$6\frac{1}{2}$	$3\frac{3}{8}$	$2\frac{1}{8}$	$1\frac{3}{8}$	2	$2\frac{3}{8}$	$\frac{7}{8}$
3 6 8 9 0	$6\frac{1}{2}$	$3\frac{5}{8}$	$1\frac{7}{8}$	$1\frac{5}{8}$	2	$2\frac{1}{8}$	1
7	$6\frac{1}{2}$	$2\frac{5}{8}$	$1\frac{5}{8}$	$\frac{5}{8}$	$1\frac{7}{8}$	$\frac{5}{8}$	$1\frac{7}{8}$
&	$8\frac{3}{4}$						

Table III  
Mechanical Spacing Table for Roman Numbers.  
See "Use of the Mechanical Spacing Tables".

Numerals	Width of Numerals AD.LT.PL.7.	AD.LT.PL.7.					
		1	2-3	4	5	6-8 9-0	7
1	$4\frac{3}{4}$	2	$1\frac{3}{4}$	1	$1\frac{1}{2}$	$1\frac{3}{4}$	1
2	$6\frac{1}{2}$	$1\frac{5}{8}$	$\frac{7}{8}$	$\frac{5}{8}$	1	1	$\frac{1}{2}$
4	6	2	$1\frac{1}{4}$	$1\frac{3}{4}$	$1\frac{1}{2}$	$1\frac{3}{4}$	$1\frac{3}{4}$
5	$6\frac{1}{2}$	$1\frac{5}{8}$	1	$\frac{5}{8}$	1	$1\frac{1}{8}$	$\frac{1}{2}$
3 6 8 9 0	$6\frac{1}{2}$	$1\frac{3}{4}$	1	$\frac{3}{4}$	1	1	$\frac{1}{2}$
7	$6\frac{1}{2}$	$1\frac{1}{4}$	$\frac{3}{4}$	$\frac{1}{4}$	$\frac{7}{8}$	$\frac{7}{8}$	$\frac{1}{4}$
&	$8\frac{3}{4}$						

Table IV  
Mechanical Spacing Table for Gothic Numbers.  
See "Use of the Mechanical Spacing Tables".

LETTERING—MECHANICAL SPACING TABLES

Letters	A	BDE FHIK LMN PRU	CG OQ S	J	T	V	W	X	Y	Z
A	$\frac{5}{8}$	$1\frac{3}{8}$	1	$\frac{3}{8}$	$-\frac{1}{4}$	0	$\frac{3}{8}$	$\frac{1}{4}$	$-\frac{1}{2}$	$\frac{3}{4}$
BDGR	$1\frac{1}{8}$	$1\frac{5}{8}$	$1\frac{1}{4}$	$\frac{3}{4}$	$\frac{5}{8}$	$\frac{1}{8}$	$1\frac{3}{8}$	$\frac{3}{4}$	$\frac{3}{8}$	$\frac{7}{8}$
CEOQS	1	$1\frac{1}{2}$	$1\frac{1}{8}$	$\frac{5}{8}$	$\frac{1}{2}$	1	$1\frac{1}{4}$	$\frac{1}{2}$	$\frac{1}{4}$	1
HIJMNU	$1\frac{3}{8}$	2	$1\frac{1}{2}$	1	$1\frac{1}{8}$	$1\frac{3}{8}$	$1\frac{5}{8}$	$1\frac{3}{4}$	$1\frac{3}{8}$	$1\frac{3}{8}$
K	$\frac{5}{8}$	$1\frac{1}{4}$	$\frac{3}{4}$	$\frac{3}{8}$	0	$\frac{1}{2}$	$\frac{5}{8}$	$\frac{1}{4}$	0	$\frac{1}{4}$
L	$\frac{1}{4}$	$\frac{3}{4}$	$\frac{1}{4}$	$\frac{1}{4}$	$-\frac{5}{8}$	$-\frac{1}{2}$	0	$\frac{1}{4}$	$-\frac{7}{8}$	$\frac{1}{4}$
P	0	$1\frac{1}{4}$	$\frac{7}{8}$	$-\frac{3}{8}$	$\frac{1}{4}$	$\frac{3}{4}$	1	$\frac{1}{4}$	$\frac{1}{8}$	$\frac{3}{4}$
FT	$-\frac{3}{8}$	$1\frac{1}{8}$	$\frac{1}{2}$	$-\frac{1}{2}$	$\frac{1}{4}$	$\frac{1}{4}$	$\frac{1}{2}$	$\frac{1}{4}$	$\frac{1}{4}$	$\frac{1}{4}$
V	0	$1\frac{3}{8}$	1	$-\frac{1}{4}$	$\frac{1}{4}$	$\frac{5}{8}$	$1\frac{1}{8}$	$\frac{1}{2}$	$\frac{1}{4}$	$\frac{5}{8}$
W	$\frac{3}{8}$	$1\frac{5}{8}$	$1\frac{1}{4}$	0	$\frac{1}{2}$	$1\frac{1}{8}$	$1\frac{1}{2}$	1	$\frac{1}{2}$	1
X	$\frac{1}{4}$	$1\frac{3}{4}$	1	$\frac{3}{8}$	$\frac{1}{4}$	$\frac{1}{2}$	1	$\frac{3}{4}$	$\frac{1}{2}$	$\frac{1}{2}$
Y	$\frac{1}{2}$	$1\frac{3}{8}$	$\frac{3}{4}$	$\frac{3}{8}$	$\frac{1}{4}$	$\frac{1}{4}$	$\frac{1}{2}$	$\frac{1}{2}$	$\frac{1}{4}$	$\frac{1}{2}$
Z	$\frac{3}{4}$	$1\frac{3}{8}$	1	$\frac{3}{8}$	$\frac{1}{4}$	$\frac{5}{8}$	1	$\frac{1}{2}$	$\frac{1}{2}$	$\frac{1}{4}$

Letter Widths For Letters on ADAMS' LETTER PL7			
A	8	N	7
B	7	O	$7\frac{1}{2}$
C	$7\frac{1}{2}$	P	7
D	7	Q	$7\frac{1}{2}$
E	7	R	7
F	7	S	7
G	$7\frac{1}{2}$	T	$8\frac{3}{4}$
H	7	U	7
I	$\frac{3}{4}$	V	8
J	$5\frac{1}{2}$	W	$10\frac{1}{2}$
K	7	X	8
L	7	Y	8
M	$8\frac{3}{4}$	Z	7

Table V  
Mechanical Spacing for Gothic Capital Letters.  
See "Use of the Mechanical Spacing Tables".



LETTERING—MECHANICAL SPACING TABLES

Letters	ac de oq s	bfh km np ru	il	t	g	j	vW XY Z
A	$3\frac{1}{2}$	$4\frac{5}{8}$	$2\frac{3}{4}$	$2\frac{3}{4}$	$3\frac{7}{8}$	$1\frac{3}{8}$	$3\frac{1}{2}$
BDGR CEOQS	$4\frac{1}{8}$	$4\frac{5}{8}$	$2\frac{1}{4}$	$3\frac{3}{8}$	$4\frac{1}{4}$	$1\frac{5}{8}$	4
HIJMNU	$4\frac{1}{2}$	$5\frac{1}{2}$	$3\frac{3}{4}$	4	$5\frac{5}{8}$	$1\frac{1}{2}$	5
K	$3\frac{3}{4}$	$4\frac{3}{4}$	$2\frac{3}{4}$	$2\frac{3}{4}$	$3\frac{7}{8}$	1	$4\frac{1}{4}$
L	$3\frac{1}{2}$	$4\frac{1}{2}$	$2\frac{1}{4}$	$3\frac{1}{4}$	$4\frac{3}{4}$	$2\frac{3}{8}$	4
P	$2\frac{3}{4}$	$4\frac{5}{8}$	$2\frac{1}{8}$	2	$4\frac{1}{2}$	$2\frac{5}{8}$	$3\frac{3}{4}$
FT	$2\frac{7}{8}$	$4\frac{1}{8}$	$1\frac{5}{8}$	$2\frac{5}{8}$	$3\frac{3}{4}$	$1\frac{7}{8}$	$3\frac{3}{4}$
VWY	$2\frac{7}{8}$	$5\frac{3}{8}$	$2\frac{3}{4}$	$2\frac{7}{8}$	3	$2\frac{1}{8}$	3
XZ	$3\frac{7}{8}$	$5\frac{3}{8}$	$2\frac{7}{8}$	$2\frac{1}{2}$	$4\frac{7}{8}$	$2\frac{3}{4}$	$4\frac{3}{4}$

Table VI  
Mechanical Spacing Table for Roman Capital Letters in Combination with Roman Small Letters.

See "Use of the Mechanical Spacing Tables."

spacing distance from the centre line of the "f" to the centre line of the following letter equal to 4 1-8. The vertical guide lines for the Roman capitals E, F and M are to be taken thru the outside of the vertical heavy stems instead of thru their centres, as given on Adams' letter plate 9.

In every instance when a spacing number is given with a minus sign before it, the spacing distance for the following letter is to be laid off to the left of the spacing guide for the preceding letter. All the rest of the spacing distances are to be laid off to the right of the spacing guide for the preceding letter.

In spacing the Roman capitals and numbers, remember that the vertical spacing guides do not pass thru the extremities of the horizontal serifs, but through the extremities of the main body of the letter.

### Word Spacing.

**In Spacing Individual Words,** or lines of words, the principles governing the spacing of the letters are to be applied. In most cases it is, however, sufficient to make the space between the words equal to the height of the letters. For words that are separated by commas, increase this distance by two units of height. The distance between the last letter of one sentence and the first letter of the next should be twice the distance used for spacing the adjacent words of either of the sentences. In spacing lines of words in a vertical direction, it is necessary, for legibility, to make the distance between the lines greater than the distance used between the words of each line. A good minimum distance is  $1\frac{1}{4}$  times the height of the letter.

### Titles.

**Preliminary.** Every drawing or sketch, as soon as it is made, should have a title placed upon it, in order to convey

to every person, who has occasion to make use of it, a concise description of what it represents. The cost of the title should be adjusted to the elaborateness and importance of the drawing upon which it is placed. Large display maps and proposal drawings should have fine appearing titles, while shop drawings should have titles that are easily read as well as cheaply constructed.

**The Title** should consist of:

(a) The name of the particular kind of representation which the drawing is intended to show; as "Assembly" or "Detail Drawing"; "The Plan"; "The Front"; "The Side"; "The Rear Elevation"; "First"; "Second"; or "Third Floor"; "Longitudinal" or "Transverse Section"; "Contour"; "Topographic" or other map; etc.

(b) The name of the specific object which the drawing represents.

(c) The name of the individual for whom the drawing is made.

(d) The name of the individual who filled the order.

(e) The address of the individual who filled the order.

(f) The date of finishing the drawing.

(g) The scale to which the drawing is made.

(h) The name of the draftsman, the authorizer, and the approver of the drawing.

(i) The contract number and the number of the drawing. These items may be rearranged to suit the particular needs of each case, and the number of items to be included can be increased or decreased as desired. But in all instances, items (a-b-c-d-f-g) are to be included somewhere in the main title. Items (h-i) may be placed either as a part of the main title or separated from it, and placed in any other convenient part of the drawing.

**The Position of the Title** on the drawing is a matter of individual judgment. It must, however, be placed

in a natural position so as to easily attract the eye of the observer.

**The Preliminary Make Up For a Title** requires:-

(a) That a concise description of the subject matter of the drawing be written down following the outline as previously given.

(b) That the description be separated into lines and arranged in some logical order, keeping in mind the amount of space available for the title.

(c) That the lines to be emphasized should be placed either near the top or the center of the proposed title.

(d) That the lines be arranged to as to make the final appearance of the title pleasing. This requires that the height as well as the length of each of the lines of words be modified to suit their particular locations in the title.

**A Pleasing Appearance** can generally be obtained by making the title so that it can be enclosed in a diamond or elliptical shaped figure. In the preliminary design of a title the space available for it should be enclosed in some such outline as mentioned. The lengths of the various lines of words composing the title can then be measured, and the proper height of letters obtained which must be used to give the length of line required as explained under "Working Methods in Study Plate 5." The enclosing rectangle for each line of words can then be placed in its proper location, and the whole title balanced for a pleasing effect before a letter is drawn. Fig. 77, shows the preliminary design for the title plate, Fig. 79, for study plate 5. Roman letters should be used for the particular parts of the title which are to be emphasized.

### STUDY PLATE 5.

**Plate Analysis.** This plate is designed to give practice in:-

(a) The development of correct working methods, in the mechanical determination of the overall length of a line

of letters when the height of the letters is given, and in the mechanical determination of the height of a line of letters when the length of the line is given.

(b) In the placing and aligning of the drawing paper, in drawing the trimming and border lines, in inking the border line, and in the rendering of the plate notation.

(c) In the drawing of pencil guide lines for lettering, and in the construction of mechanical letter spacing scales.

(d) In the preliminary determination of the line lengths of a series of words composed either of Roman capitals, of Roman capitals and small letters, of Gothic capitals, or of Roman numbers.

(e) In the subsequent placing of the calculated length of line central with the centre line of the proposed title, the mechanical spacing of the letters and words, the preliminary suggestion of the letters, and the final rendering of their outline in pencil.

(f) In the finished rendering in ink of the letters, as outlined in Pencil, with the Gillott 303 and ball point pens.

**The Size of the Finished Plate** is to be  $13\frac{3}{4}'' \times 19\frac{3}{4}''$ .

**The Plate Requires** a finished rendering in ink upon white "Normal" paper of the title shown in Fig. 79.

**The Equipment Required** consists of drawing board, T-square, 15"x22" sheet of white "Normal" paper, thumb tacks, 5H drawing pencil, architect's scale, pencil sharpener, bottle of ink, 30 x 60 degree triangle, ruling pen, fine point pen, ball point pen, pen holder, pen wiper, blotter, pencil eraser, ink eraser, and Adams' letter plates 7, 9 and 11.

**Working Methods.****To Determine the Overall Length of a Given Line of Words When the Height of the Letters is Fixed.**

- (a) Decide upon the style of letters to be used.
- (b) Turn to the mechanical spacing table given for the style of letter chosen.
- (c) Write down the letters composing the line of words upon a sheet of paper. Do not join the letters together but leave a space of approximately  $\frac{1}{4}$ " between each letter, and double this space between each of the words.
- (d) Opposite each of the letters as written down, write down the number, representing their respective widths, taken from the proper mechanical spacing table.
- (e) Opposite each of the spaces between the letters and between the words, write down the number, representing their respective widths, as taken from the proper spacing table. Keep this line of numbers separated entirely from the line of numbers written in (d).
- (f) Add up the numbers, representing the widths of the letters, and write down their sum at the end of the line.
- (g) Add up the numbers, representing the widths of the spaces between the letters, and write down their sum at the end of the line.
- (h) Add the sum of the spaces to the sum of the letter widths, and write down the total sum. This last sum represents the total length of the line in units of height.
- (i) The exact length of the line can be found in inches by using the equation:

$$\frac{H \times S}{8}$$

where L equals length, in inches, of the word or line of words.

H equals the distance, in inches, included between the horizontal guide lines, which limit the tops and bottoms of the letters composing the words.

S equals the total number of units in the complete word or line of words, as found by summing up the numbers representing the letter widths and the spaces between the letters.

Example: It is required to find the length of the first line "A COURSE IN" of the title on study plate 5, constructed of Roman capital letters, as called for upon the preliminary design sheet, Fig 77. The overall height of the letters is to be  $\frac{1}{2}$ ", which is the distance included between horizontal guide lines, limiting the tops and bottoms of the letters. The following procedure agrees with the above outline:

- (a) Roman capitals required.  
 (b) See Mechanical Spacing Table I.

(c)	(d)	(e)
A		8
C	$7\frac{1}{2}$	$2\frac{1}{4}$
O	$7\frac{1}{2}$	3
U	7	4
R	7	$2\frac{1}{2}$
S	7	3
E	$7\frac{5}{8}$	8
I	$1\frac{1}{4}$	4
N	7	
	<hr/> 59 $\frac{7}{8}$	<hr/> 34 $\frac{3}{4}$
		<hr/> 49 $\frac{5}{8}$

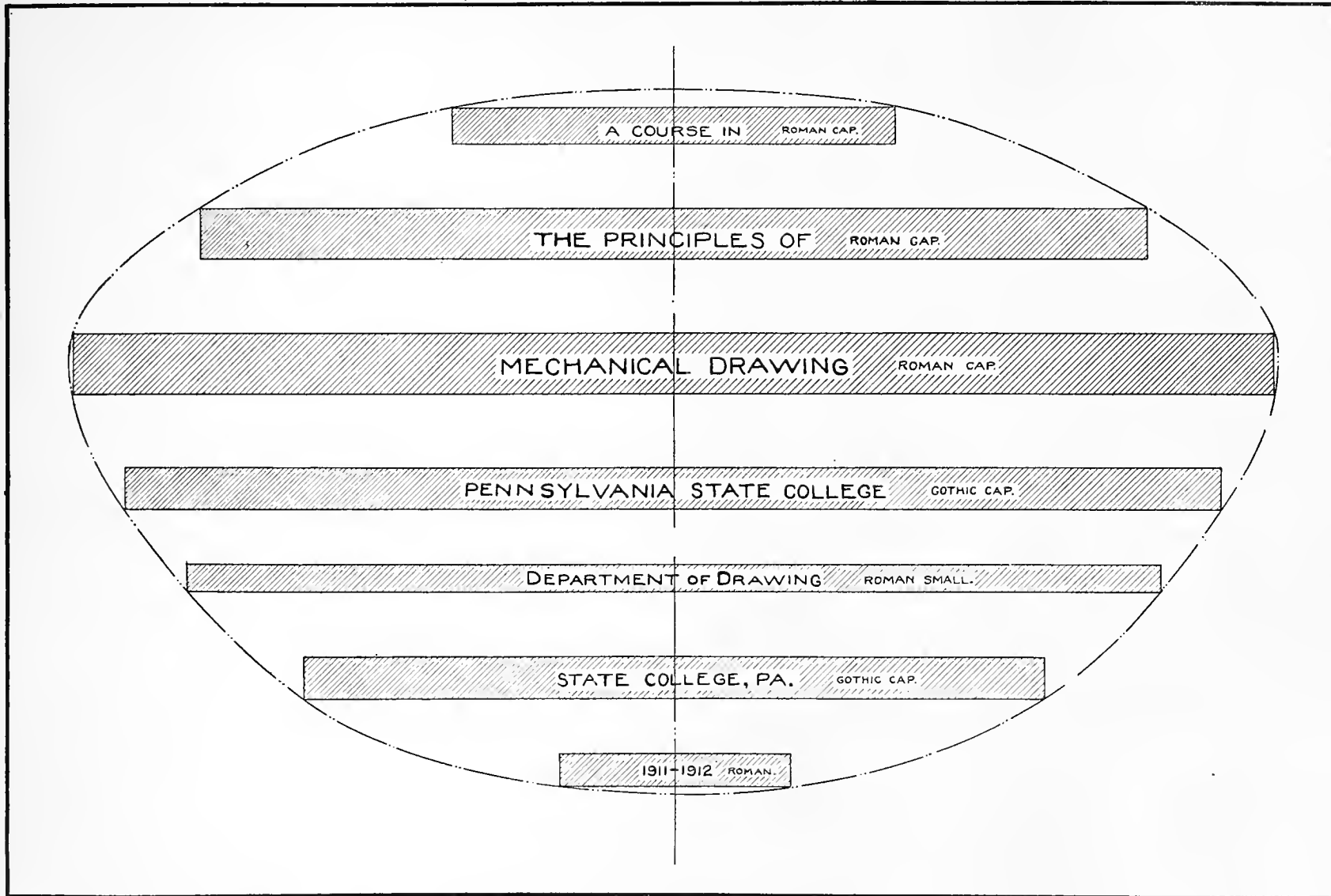

Fig. 77.— Preliminary Design Sheet for Study Plate 5.

- (f)  $59\frac{7}{8}$  units total in the letters.  
 (g)  $34\frac{3}{4}$  units total in the spaces.  
 (h)  $94\frac{5}{8}$  units total in the entire line.

$$(i) L = \frac{H \times S}{8}$$

$$L = \frac{\frac{1}{2} \times 94\frac{5}{8}}{8}$$

$$L = 5.91" \text{ or } 5\frac{7}{8}" \text{ long.}$$

**To Determine the Height of a Given Line of Words When the Length of the Line is Fixed.**

(a) to (h). Follow steps (a) to (h) inclusive as given in the preceding problem, "To find the length of a given line of words when the height of the letters is fixed".

(i) The exact height of the letters, or in other words, the distance that the horizontal guide lines, which limit the top and bottom parts of the letters, are to be spaced apart, can be found from the equation:

$$H = \frac{8 \times L}{S}$$

where H equals height of the letters in inches.

L equals length of the line of words in inches.

S equals total number of units in the line of words as found by summing up the numbers representing the letter widths, and spaces between the letters.

Example: It is required to find the height of the first line "A COURSE IN" of the title on study plate 5, constructed of Roman capital letters as called for on the preliminary design sheet, Fig. 77. The overall length of the line is to be  $57\frac{7}{8}$ ".

The following procedure agrees with the above outline:

- (a) Roman capitals required.  
 (b) See Mechanical Spacing Table I.

(c)	(d)	(e)	
A	8	8	
C	$7\frac{1}{2}$	$2\frac{1}{4}$	
O	$7\frac{1}{2}$	3	
U	7	4	
R	7	$2\frac{1}{2}$	
S	7	3	
E	$7\frac{5}{8}$	8	
I	$1\frac{1}{4}$	4	
N	7		
	$59\frac{7}{8}$	$34\frac{3}{4}$	$94\frac{5}{8}$

- (f)  $59\frac{7}{8}$  units total in the letters.  
 (g)  $34\frac{3}{4}$  units total in the spaces.  
 (h)  $94\frac{5}{8}$  units total in the entire line.

$$(i) H = \frac{8 \times L}{S}$$

$$H = \frac{8 \times 5.875}{94.625}$$

$H = .49" \text{ or } \frac{1}{2}"$  the required height of the line of letters.

**Schedule of Operations.****Placing and Aligning the Drawing Paper.**

1. Place the 15" x 22" sheet of "Normal" paper on the board, and with its long edges parallel to the long edges of the board, and with its top and left hand edges about 1" away from the corresponding edges of the board and approximately parallel to them. Insert a thumb tack in each of the four corners.

**Drawing Trimming Line.**

2. With the T-square and drawing pencil, draw a light horizontal line the entire length of the plate, about  $\frac{1}{4}$ " below its top edge. See layout sheet, Fig. 78.

3. With the T-square, 30-60 degree triangle, and drawing pencil, draw a light vertical line the entire width of the plate and about 1" from its left hand edge.

4. Using the edge of the scale which is divided into 1-16ths, with its zero mark, over the point of intersection of the top and left hand trimming lines drawn in (2) and (3), lay off a distance of  $19\frac{3}{4}$ " along the top trimming line, and  $13\frac{3}{4}$ " along the left hand trimming line.

5. With the T-square and drawing pencil, draw a light horizontal trimming line the entire length of the plate thru the last point laid off in (4).

6. With the T-square, 30-60 degree triangle, and drawing pencil, draw a light vertical line the entire width of the plate thru the first point laid off in (4).

**Drawing Border Line.**

7. With the scale and drawing pencil, lay off a distance of  $\frac{7}{8}$ " perpendicular to and inside of each of the four trimming lines just drawn.

8. With the T-square and drawing pencil, draw light horizontal lines thru each of the points laid off perpendicular

to the top and bottom trimming lines respectively. Start and stop these lines inside of the end trimming lines.

9. With the T-square, 30-60 degree triangle, and drawing pencil, draw light vertical lines thru each of the points laid off, perpendicular to the end trimming lines. Start and stop these lines upon the top and bottom horizontal lines drawn in (8).

**Inking Border Line.**

10-14. For steps 10 to 14 inclusive, follow the corresponding steps in the outline for study plate 4.

**Plate Notation.**

15-17. For steps 15 to 17 inclusive, follow the corresponding steps in the outline for study plate 4, and note that this plate is number 5.

**Drawing Horizontal Pencil Guide Lines for Lettering.**

18. With the zero of the scale, placed over the upper left hand corner of the border line, point off along the left hand border line the dimensions given on the layout sheet Fig. 78, for the spacing of the horizontal lettering guide lines. Work from the top of the sheet downward and point off as many divisions as possible with one setting of the scale. Exercise care to get the distances exactly as called for.

19. With the T-square and the 5H chisel edged pencil, proceed to draw thru these several points of division light horizontal guide lines the full length of the plate included between the two vertical lines forming part of the border line.

20. With the scale lay off the point which will divide the bottom border line into two equal parts.

21. With the T-square, 30-60 degree triangle, and 5H pencil, draw a light vertical line thru the point laid off in (20) the full width of the plate between the top and bottom border

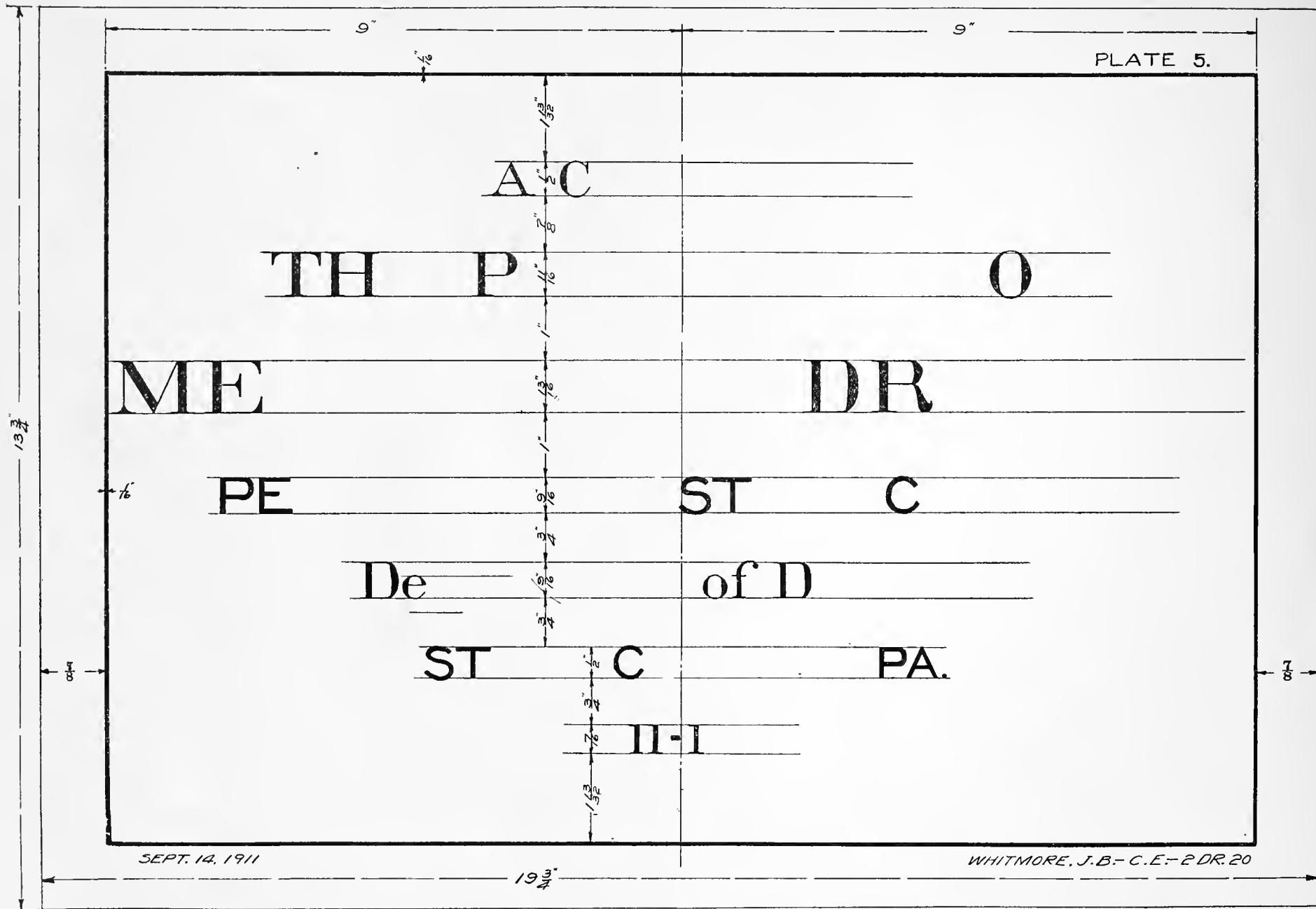

Fig. 78.—Layout Sheet for Plate 5.



lines. This line will be the vertical center line of the plate and also of the title.

#### Construction of Mechanical Spacing Scales.

22. Upon the edge of a small piece of drawing paper, lay off the exact distance  $\frac{1}{2}$ " , included between the horizontal guide lines for the top line of the title. With a very sharp pencil, carefully divide the distance laid off on the paper scale into 8 equal parts. Write upon the paper scale when finished, "For lines 1 and 6 of the title". Be very careful not to lose the paper scale.

23. Proceed as in (22) to construct a paper scale for the second line of the title, which is to be 11-16" between horizontal guide lines. When finished, write upon it, "For line 2 of the title".

24. Proceed as in (22) to construct a paper scale for the third line of the title, which is to be 13-16" between horizontal guide lines. When finished, write upon it, "For line 3 of the title".

25. Proceed as in (22) to construct a paper scale for the fourth line of the title, which is to be 9-16" between horizontal guide lines. When finished, write upon it, "For lines 4 and 5 of the title".

26. Proceed as in (22) to construct a paper scale for the seventh line of the title, which is to be 7-16" between horizontal guide lines. When finished, write upon it, "For line 7 of the title."

**The Preliminary Determination of the Line Length of a Series of Words Composed of Roman Capital Letters, the Subsequent Placing of the Calculated Line Length Central With the Center Line of the Title, the Mechanical Spacing of the Letters and Words, the Preliminary suggestion of the Letters and the Final Rendering of Their Outline in Pencil.**

27. Upon a separate sheet of paper, set down in a line the letters composing the words of the first line of the title, Fig. 79.

28. Using the Mechanical Spacing Table I, for the Roman capital letters, and following the outline given in the working methods for finding the length of a line of letters when the height is given, proceed to determine the exact length of the first line of the title in inches, as written down in (27). Leave a space of 8 units between the right hand vertical guide line of the last letter of the preceding word and the left hand vertical guide line of the first letter of the next word for all words composed of Roman capital letters.

29. With the scale, lay off to the left of the vertical centre line of the plate and along the bottom horizontal guide line for the first line of the title, a distance equal to one half of the length of this particular line as determined in (28) or  $2\frac{1}{8}$ ".

30. Using the paper scale as constructed in (22), for the first line of the title, and starting the line at the point laid off in (29), proceed to lay off to the right along the bottom horizontal guide line the distances called for upon the separate sheet upon which the letter widths and spacing distances were first written down (27). This will have to be done very carefully and accurately as otherwise the line as laid off will come out longer than the calculated length. If this is the case, respace until it comes out within 1-8" of the distance as calculated.

31. With the T-square, triangle, and drawing pencil, draw short, light, vertical guide lines thru the points of division in (28), to intersect both of the horizontal guide lines

A COURSE IN  
THE PRINCIPLES OF  
MECHANICAL DRAWING  
PENNSYLVANIA STATE COLLEGE  
Department of Drawing  
STATE COLLEGE, PA.  
1911-1912

for the first line of the title. Along the first vertical guide line as drawn, lay off a distance of four units with the paper scale, measuring from the bottom horizontal guide line up towards the top horizontal guide line. With the T-square and pencil, draw a light, horizontal center line thru this point the entire length of the line of words as laid off, but not the entire length of the plate.

32. Using Adams' letter plate 9 as a guide, proceed to first suggest the letters in the first line of the title and then to render their finished outline. Make a judicious use of the paper scale to keep uniform the widths of the stems, the lengths of the serifs, and all other details of the various letters which can be laid off by its use. Remember that all of the dimension figures given upon the letter plate can be laid off from the paper scale. Do not make the pencil outlines any heavier than absolutely necessary for good work. Do not fill in the heavy stems or spurs. In order to successfully render the letters in ink, these precautions must be observed. Follow the notes as given in connection with the Spacing Table I, as well as the letter plate 9, in the actual construction of the letters. Note that the top of the A, and the top and bottom of the C-O-S extend beyond the horizontal guide lines.

33. Proceed according to steps (27) to (32) inclusive, and draw in the pencil outlines for the second line of the title. Use the spacing scale, as constructed in (23), in laying off the letter widths and the spacing distances. The heights of the letters are to be 11-16". Note that the top and bottom of the C-O-S extend beyond the horizontal guide lines.

34. Proceed according to steps (27) to (32) inclusive, and draw in the pencil outlines for the third line of the title. Use the spacing scale, as constructed in (24), in laying off the letter widths and the spacing distances. The heights of

the letters are to be 13-16". Note that the top of the A, and the top and bottom of the C and G, extend beyond the horizontal guide lines. Unless the paper scale for this line is very accurately constructed, and the distances laid off from it in an accurate manner, it will be difficult to keep this line of the title from extending over the right hand border line.

**The Preliminary Determination of the Line Lengths of a Series of Words Composed of Gothic Capital Letters, the Subsequent Placing of the Calculated Line Letters Central With the Center Line of the Title, the Mechanical Spacing of the Letters and Words, the Preliminary Suggestion of the Letters, and the Final Rendering of Their Outline in Pencil.**

35. Proceed according to steps (27) to (32) inclusive, and draw in the pencil outlines for the fourth line of the title. Use the spacing scale as constructed in (25) in laying off the letter widths and the spacing distances. The height of the letters is to be 9-16". As this line is to be constructed of Gothic capitals, use Adams' letter plate 7 in conjunction with the Mechanical Spacing Table V, in place of the letter plate and spacing table for the Roman letters as called for in the above steps. Note that the top of the A, the bottom of the V, and the top and bottom of the S-C-O-G extend beyond the horizontal guide lines. The spacing distance between words constructed of Gothic capitals, is to be six units in place of the eight units called for in the above steps for the Roman letters. In the actual drawing of the letters be careful not to get the vertical guide lines confused when two adjacent letters have a negative spacing. In summing up the total units in the length of the line of words, be sure to subtract the sum of the negative numbers from the sum of the positive numbers to get the net actual length of the line in units.

36. Proceed according to steps (27) to (32) inclusive, and draw in the pencil outlines for the sixth line of the title. Use the spacing scale as constructed in (22) in laying off the

letter widths and spacing distances. The height of the letters is to be  $\frac{1}{2}$ ". As this line is to be constructed of Gothic capitals, use Adams' letter plate 7 in conjunction with Mechanical Spacing Table V, instead of the letter plate and spacing table for the Roman letters as called for in the above steps. Note those letters that extend beyond the horizontal guide lines. Space the words "State College" 6 units apart, and space the word "Pa." 8 units from the word "College". The comma and period are to be 2 units respectively from the ends of the preceding words. In drawing the actual letters, and also in finding the net actual length of the line, watch out for the negative spacing of some of the letter combinations.

**The Preliminary Determination of the Line Lengths of a Series of Words Composed of Roman Small Letters, the Subsequent Placing of the Calculated Line Length Central With the Center Line of the Title, the Mechanical Spacing of the Letters and Words, the Preliminary Suggestion of the Letters and the Final Rendering of Their Outline in Pencil.**

37. Upon a separate sheet of paper, set down on a line the letters composing the words of the fifth line of the title, Fig. 79.

38. Using the Mechanical Spacing Table I, for the Roman capital letters, write down underneath the first letters of the words "Department" and "Drawing" their respective widths.

39. Follow the numbers written down in (38), with the spacing distance for the right hand vertical guide line of the capital letter to the center line of the next following small letter in each of the words mentioned in (38). This distance is to be taken from Mechanical Spacing Table VI.

40. Using the Mechanical Spacing Table II, for the Roman small letters, proceed to set down the center line spacing distances for each pair of adjacent letters in succession.

Note that the table gives the spacing for the Roman small letters to their center lines in every case, and in this respect does not strictly adhere to the method for spacing some of these letters as given on letter plate 11. When the last letter of the first word is reached, write down, immediately following the center line spacing for that letter, the width ( $1\frac{1}{2}$ ) of the letter "t" from its center line to its right extremity Fig. 76. Follow this by the arbitrary width ( $5\frac{1}{2}$ ) for the space between the end of the "t" and the beginning of the "o" in "of" then by the width ( $2\frac{5}{8}$ ), letter plate 11, of the space from the left extremity of the "o" to its center line, then by the width ( $7\frac{1}{4}$ ) of the space between the center lines of the "o" and the "f", Table II, then by the width ( $1\frac{1}{2}$ ) of the space between the center line of the "f" and its right extremity, Fig. 76, then by the arbitrary width ( $5\frac{1}{2}$ ) from the right extremity of the "f" to the left vertical guide line of the capital "D" of "Drawing". Proceed with the rest of the letters in the regular way up to the center line of the "g", then add the width ( $2\frac{7}{8}$ ), letter plate 11, of the space between the center line of the "g" and its right extremity.

41. Add up the spacing numbers as written down in (40), to obtain the total units in the line.

42. Using the equation  $L = \frac{H \times S}{8}$ , as given in the working methods, find the length of the line in inches.

43. Follow procedure in step (29).

44. Using the paper scale as constructed in (25), for the fifth line of the title, and starting the line at the point laid off in (43), proceed to lay off to the right, along the bottom horizontal guide line, the distances called for on the separate sheet upon which the spacing distances were written down, see (37) to (40) inclusive.

45. With the T-square, triangle, and drawing pencil, draw short light vertical guide lines, thru the points of divi-

sion in (44), to intersect both of the horizontal guide lines for the fifth line of the title. Along the first vertical guide line as drawn, lay off distances of 3 units, with the paper scale, measuring down from the top and bottom horizontal guide lines in each instance. Then with the T-square and drawing pencil, draw a horizontal guide line thru each of these points the entire length of the line of words as laid off, but not to extend the entire length of the plate. The horizontal line 3 units below the top horizontal guide line is used to limit the tops of the small letters as well as the curved parts of both the "ascenders" and "descenders". The horizontal line 3 units below the bottom horizontal guide line is used to limit the bottoms of the "descenders".

46. Using Adams' letter plate 9 as a guide, suggest the capital letter "D" of the first and last words, and then render their finished outline in pencil. Do not fill in their stems.

47. Using Adams' letter plate 11 as a guide, suggest the small letters in pencil. Make a judicious use of the paper scale in order to keep uniform the widths of the letters, the widths of the stems, the extensions of the serifs, and all other details which can be laid off by its use. Follow the notes, given in connection with the use of the mechanical spacing tables, very closely as the actual construction of the letters progresses.

**The Preliminary Determination of the Line Lengths of a Series of Roman Numbers, the Subsequent Placing of the Calculated Line Length Central With the Center Line of the Title, the Mechanical Spacing of the Numbers, the Preliminary Suggestion of the Numbers, and the Final Rendering of Their Outline in Pencil.**

48. Proceed according to steps (27) to (32) inclusive, and draw in the pencil outlines for the seventh line of the

title. Use the spacing scale as constructed in (26) in laying off the number widths and spacing distances. The height of the numbers is to be 7-16". Use the Mechanical Spacing Table III instead of the one called for in the above steps for the Roman capitals. Leave a distance of 10 units between the "1911" and "1912", comprising the line. The dash is to be 2 units long and placed just above the horizontal center line of the numbers, and in the exact center of the space between the "1911" and "1912".

**The Finished Rendering in Ink of the Letters as Already Outlined in Pencil.**

49. With the Gillott 303 pen and black drawing ink, proceed very carefully, to outline the letters in the first line of the title. Do not attempt to fill in either the stems or the spurs, until the letter outlines for the entire line have been inked completely, and are thoroughly dry. Then with the ball point pen proceed to fill in the stems. Do not use an excess of ink, but only enough to give a uniform black appearance to the whole letter.

50. Proceed according to (49) for the second line.

51. Proceed according to (49) for the third line.

52. Proceed according to (49) for the fourth line.

53. Proceed according to (49) for the fifth line.

54. Proceed according to (49) for the sixth line.

55. Proceed according to (49) for the seventh line.

56. With the pencil eraser, proceed to clean very carefully all the white parts of the drawing. Do not under any conditions rub the eraser over the inked letters, as their sharp black appearance will be seriously marred.

57. Remove the thumb tacks from the plate. Trim the plate along the pencil trimming line. **HAND IT TO YOUR INSTRUCTOR WHEN CALLED FOR, AND DO NOT ROLL OR FOLD.**

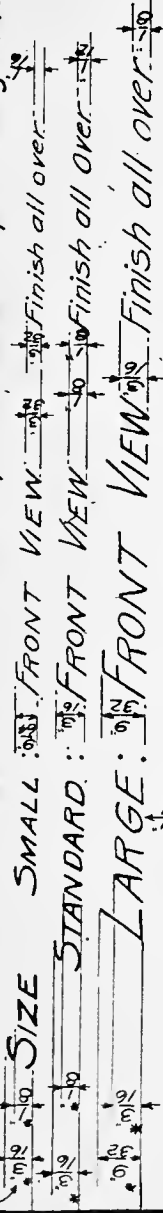

PLATE 6

LETTERING-LINE NOTATION-DIMENSIONING

CAPITAL LETTERS: Are used for headings and titles.

SMALL LETTERS: Are used for all descriptive matter except headings and titles



LINE NOTATION

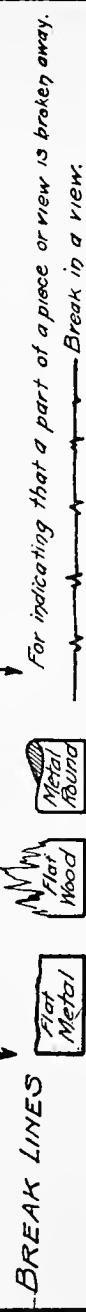
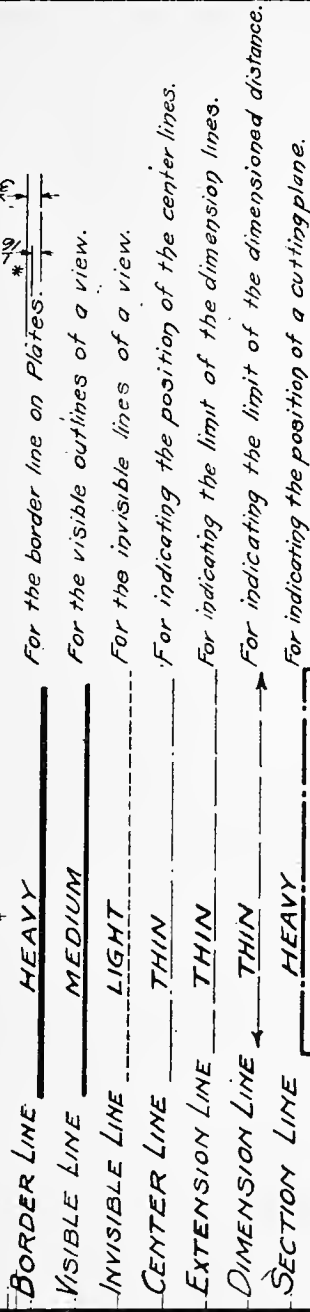

The lines shown are for pen work. The relative widths of the lines must be kept the same, while the actual widths may be varied always in the same proportion to accommodate the style and size of the drawing. In pencil work the center line should be a thin full line. It is not necessary to preserve the line contrast in penciling as required in inking and tracing. In placing extension and dimension lines, the broken character of these lines should be used to avoid direct intersections. The extension lines should not touch the outline from which it is projected. Extension lines for the same dimension line must always be drawn parallel to each other and perpendicular to the line or surface whose dimension is to be shown. Dimension lines must always be drawn parallel to the line or surface whose measurement is to be shown.

DIMENSIONING

Working or mechanical drawing is made up of three parts, viz: picture, dimensions and written matter. The picture shows various views of the object. The first requisite of the views of the object is to show its exact shape and design; second, to serve as a means for setting forth its dimensions. Both of these requisites are equally important.

In dimensioning, the draftsman must anticipate the needs of the shop, and give every necessary dimension in such a manner that it will not be necessary for the shop to add or subtract in order to get the dimension desired. Arrange the views so that the dimensions may be placed in their most natural position, without crowding, and wherever possible outside of the view itself. Do not repeat dimensions given in one view in another view, unless the repetition will make the drawing easier to read. Give all dimensions less than 24" in inches, and allow 24" in feet and inches. Never place a dimension upon a center line or upon any other line which is a part of the view being dimensioned. Where the dimension for any distance is composed of several short dimensions, always give the overall dimension outside of the series of short dimensions. Dimension figures always read in the direction of the dimension line and not at right angles to it. Every dimension must show clearly the points between which the measurement is made. Stop the extremities of the dimension line upon the extension lines which limit it. No dimension figure should be upside down when reading the drawing from the bottom, and right hand edge of the sheet. Place feet and inch marks at a reversed slope to that of the figures. Show horizontal separating line between figures representing feet and inches. Show similar line between numerator and denominator of fractions.

JANUARY 25, 1912. WHITMORE. J.B. C.E. I-DR. 20.

\* Dimensions Are Full Size And Are Not to Appear on Student's Plate.

10 1/4



DETAILS  
35'-0" SPAN ROOF TRUSS

Scale: 1"=1'-0"

$\frac{3}{4}$ " Rivets.  $\frac{13}{16}$ " Holes

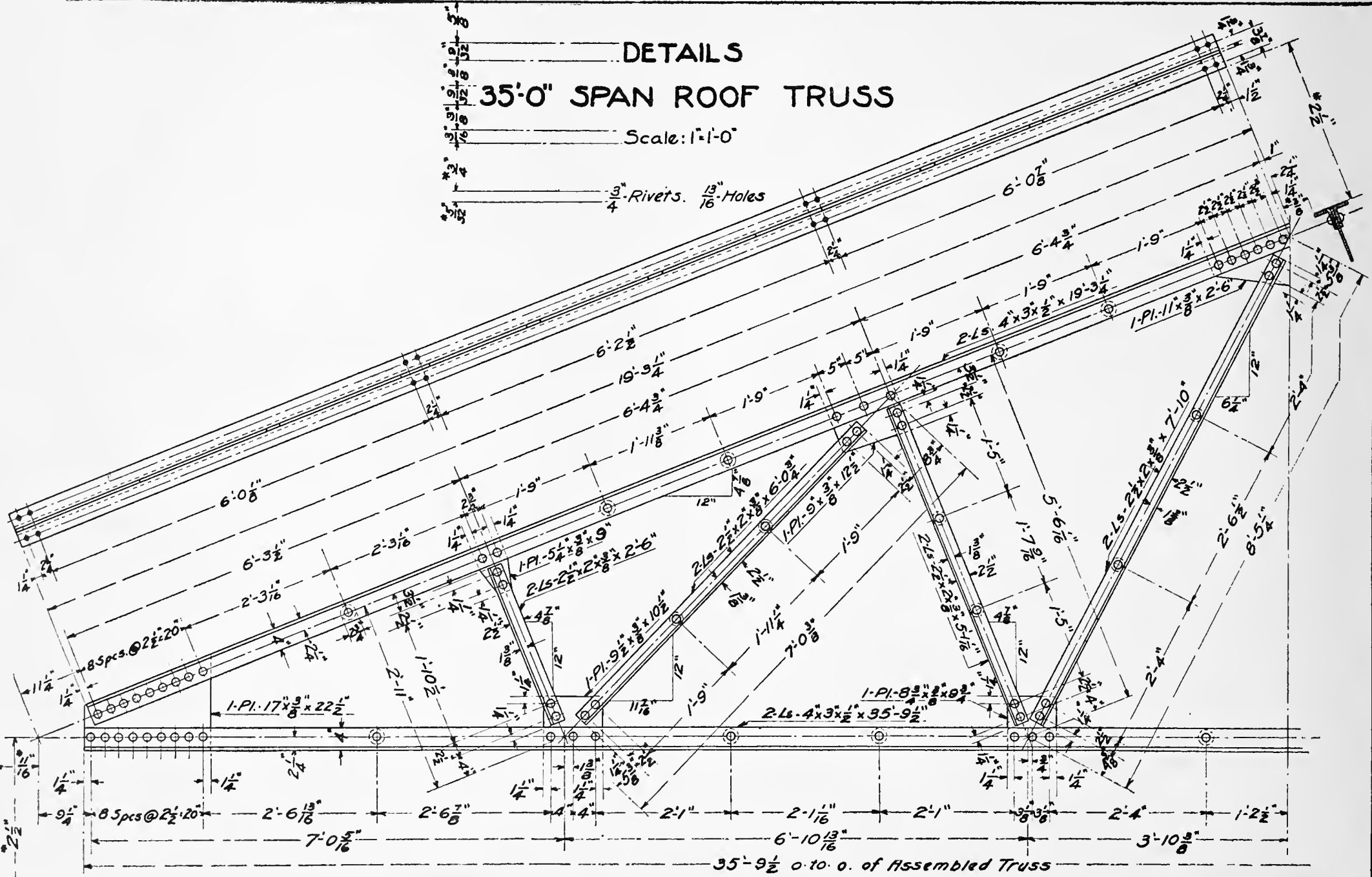

\* Dimensions Are Not To Show On Students Plate.

JULY 15, 1912.

WHITMORE, J.B. - C.E. - 1-DR. 21.

WSM



\*Dimensions are full size and are not to appear on the Student's plate.

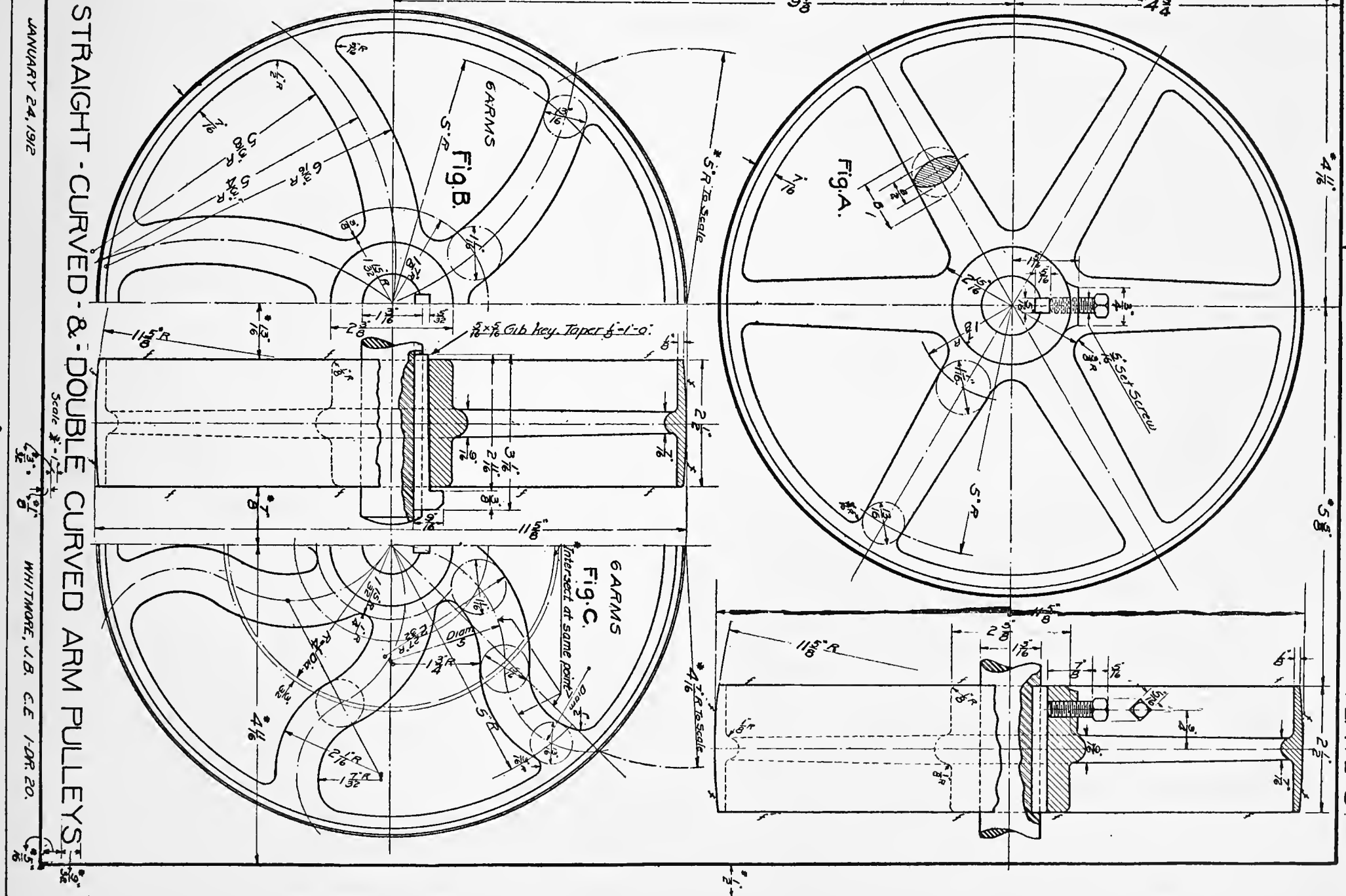

PLATE 8

# GEOMETRICAL CONSTRUCTION

PENNSYLVANIA STATE COLLEGE

DEPARTMENT OF DRAWING

Full Size.

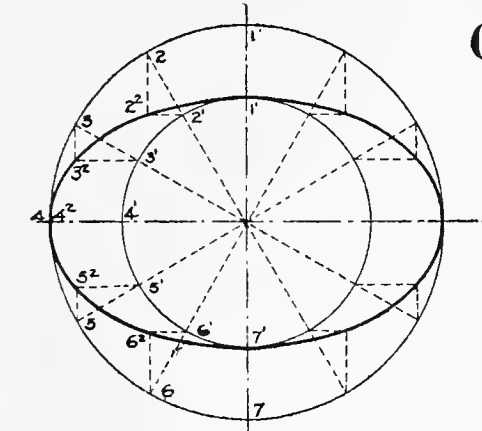

ELLIPSE

A B C

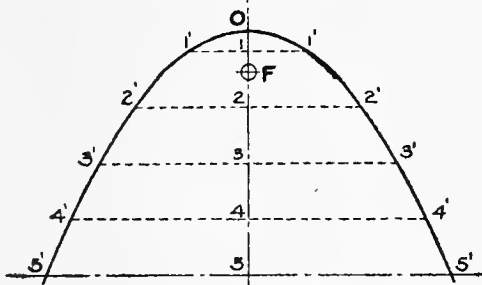

PARABOLA

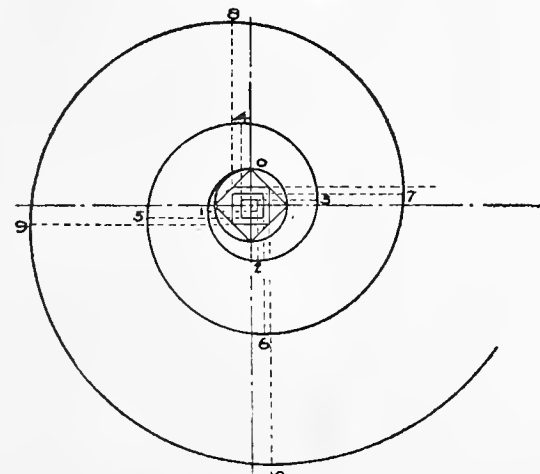

VARIABLE SPIRAL

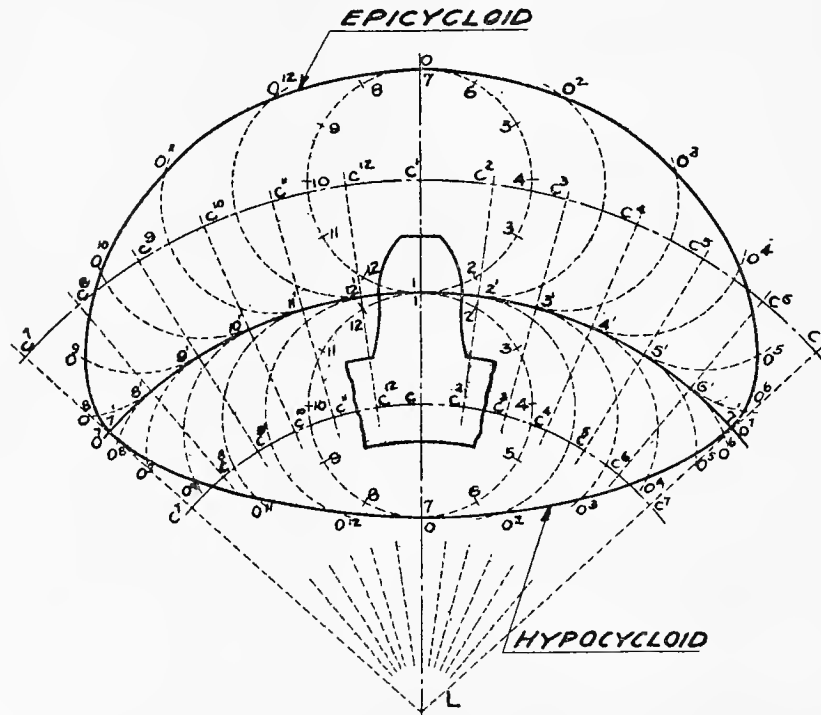

EPICYCLOID

HYPOCYCLOID

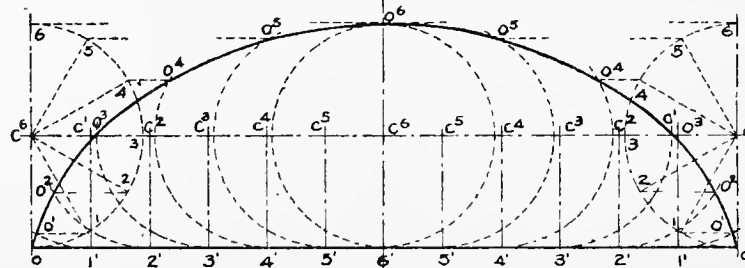

CYCLOID

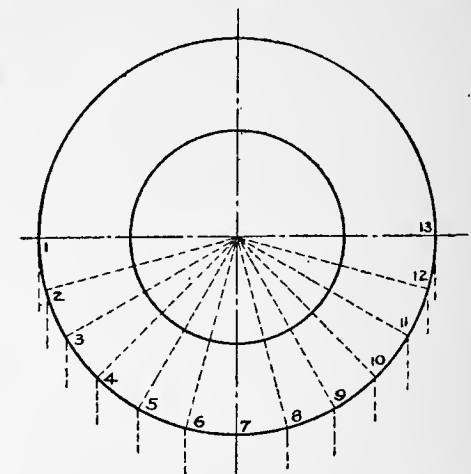

HELIX

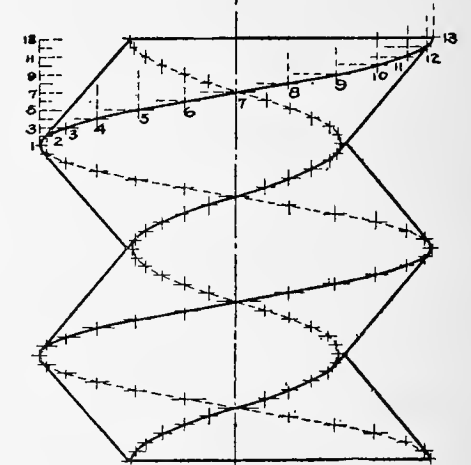

INVOLUTE

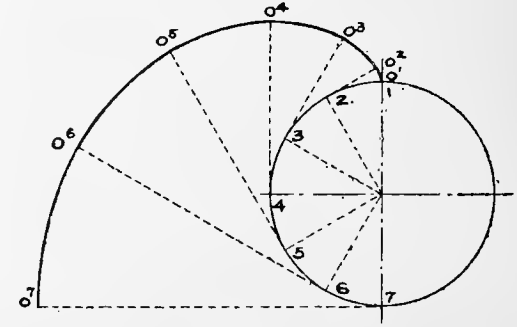

WSH

WHITMORE · J.B. · C.E. · 1-DR. 21.

JULY 15, 1912.

PLATE 9A

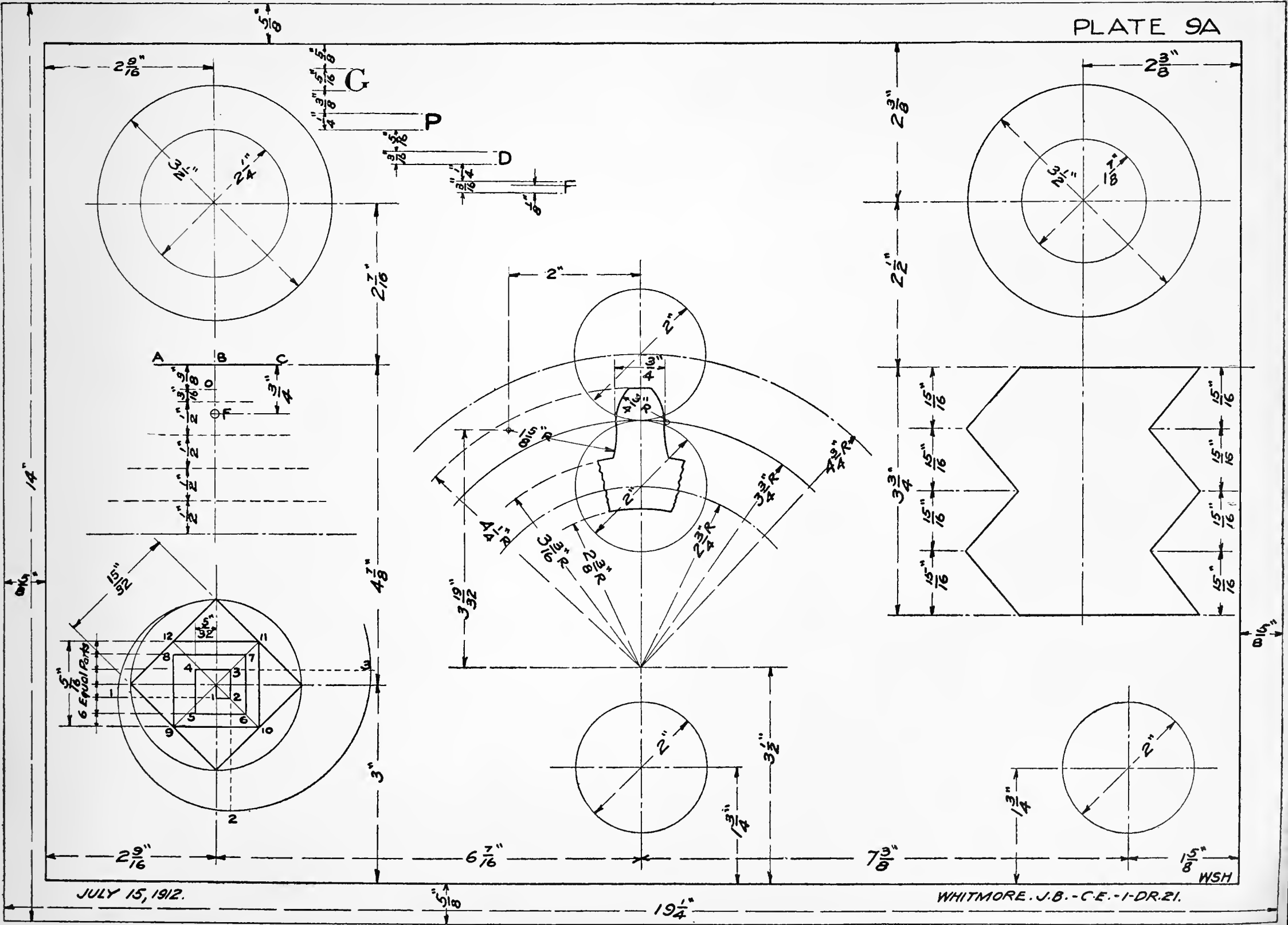

JULY 15, 1912.

WHITMORE, J.B. - C.E. - 1-DR. 21.

WSH

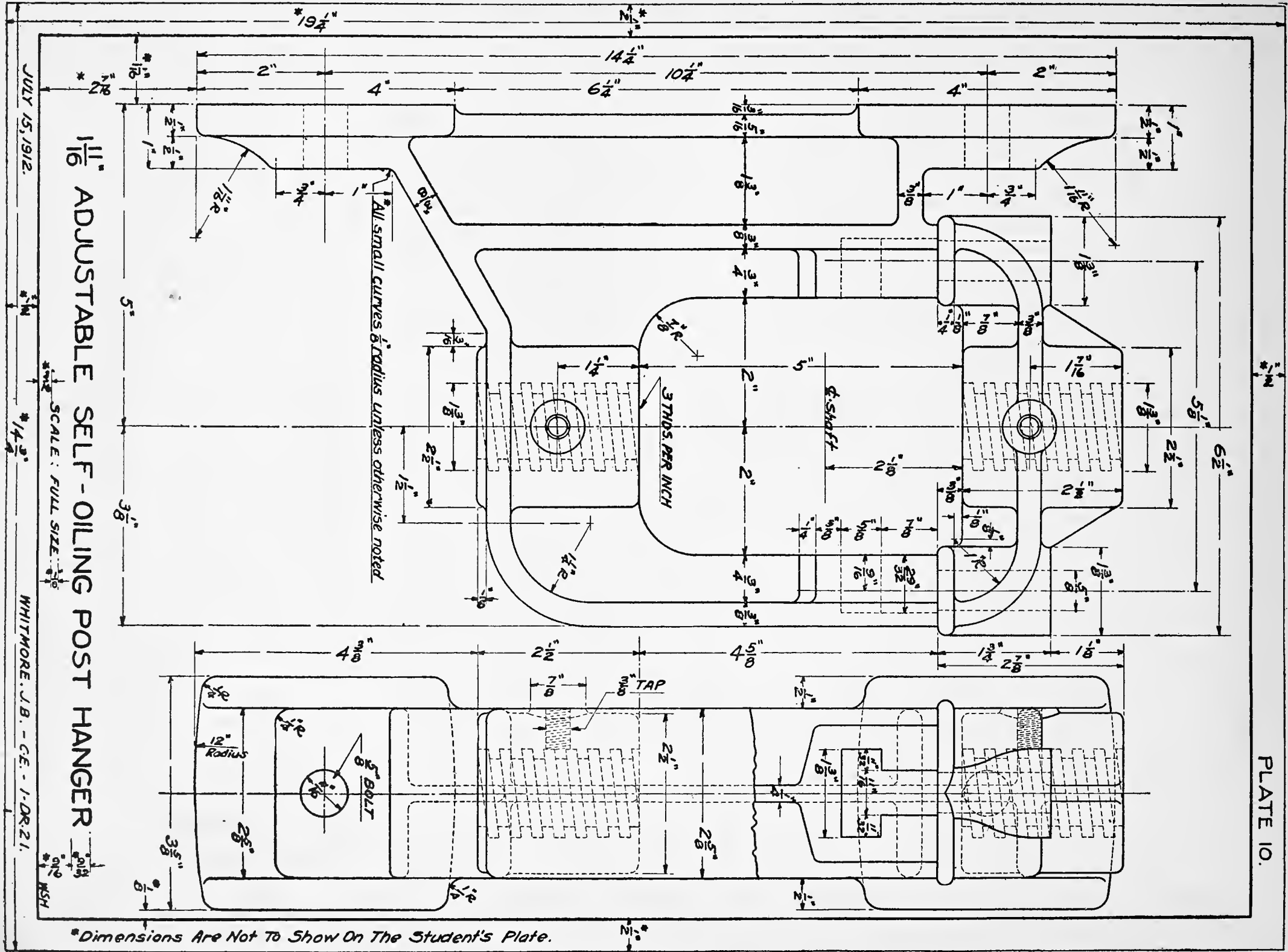

PLATE 10.

All small curves  $\frac{1}{8}$  radius unless otherwise noted

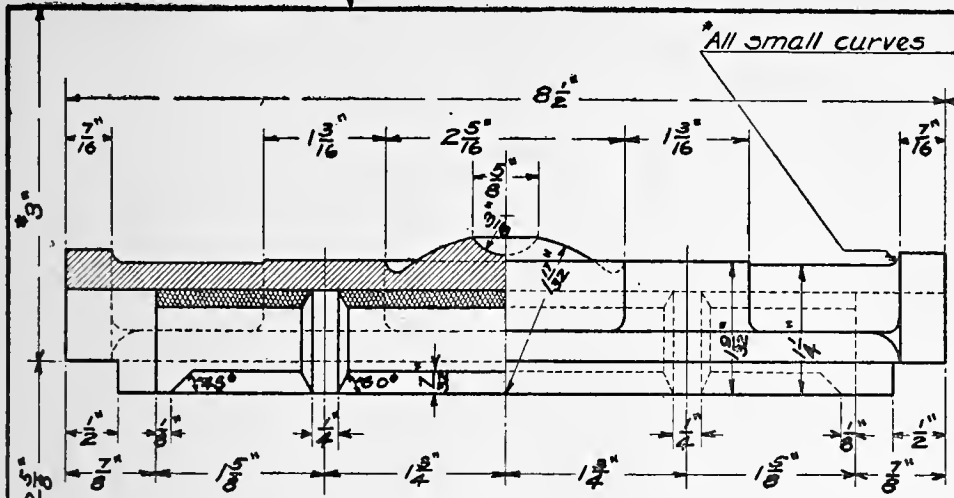

Fig. A

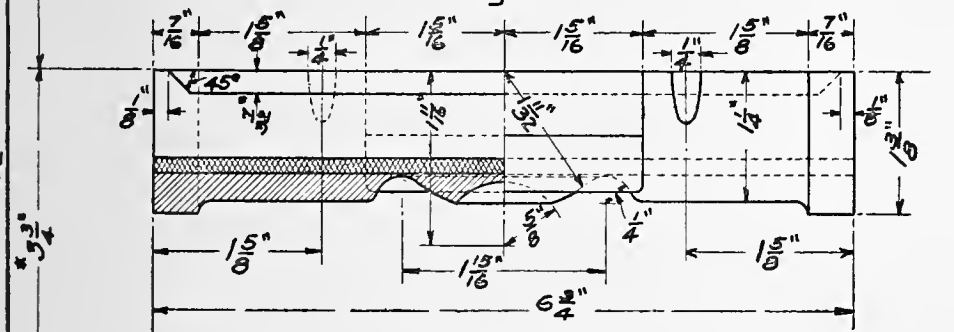

Fig. B

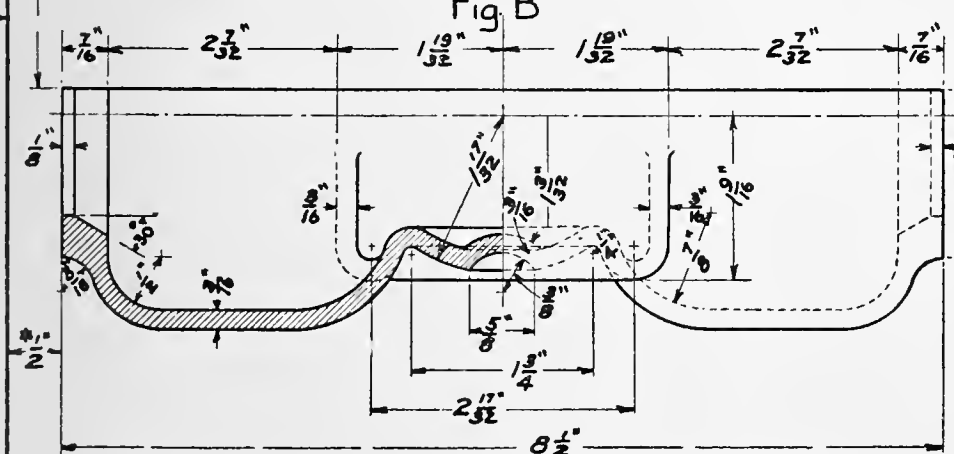
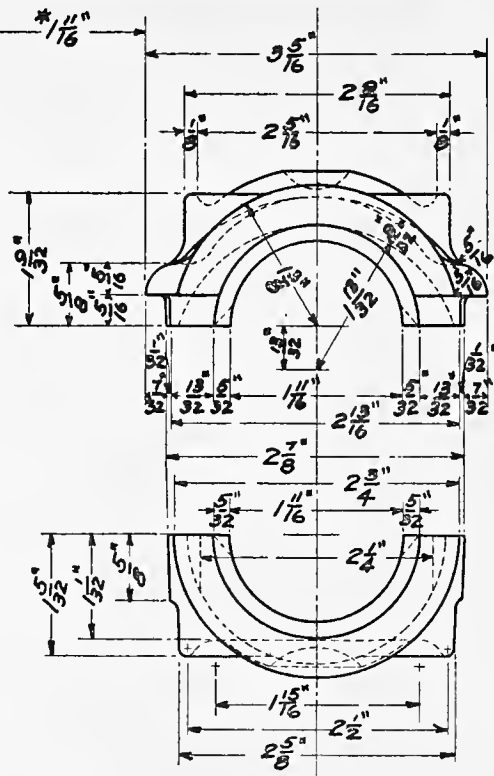

Fig. C



Full Size

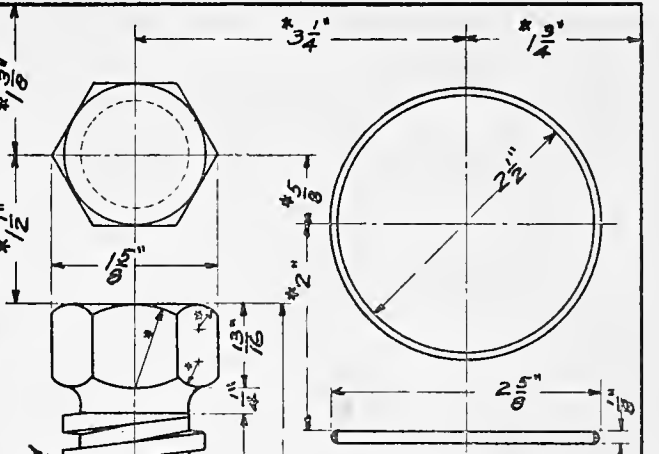
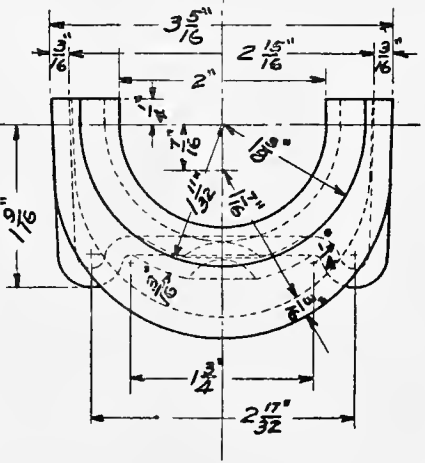

Fig. E

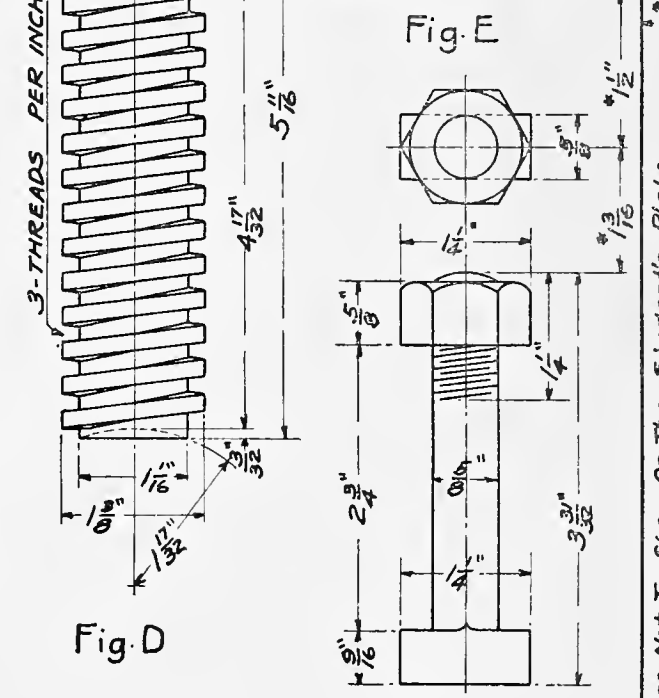

Fig. F

3-THREADS PER INCH

$1\frac{11}{16}$  ADJUSTABLE SELF-OILING POST HANGER

JULY 15, 1912.

WHITMORE, J.B.-CE.-1-DR. 21.

Dimensions Are Not To Show On The Student's Plate.

W.S.H.

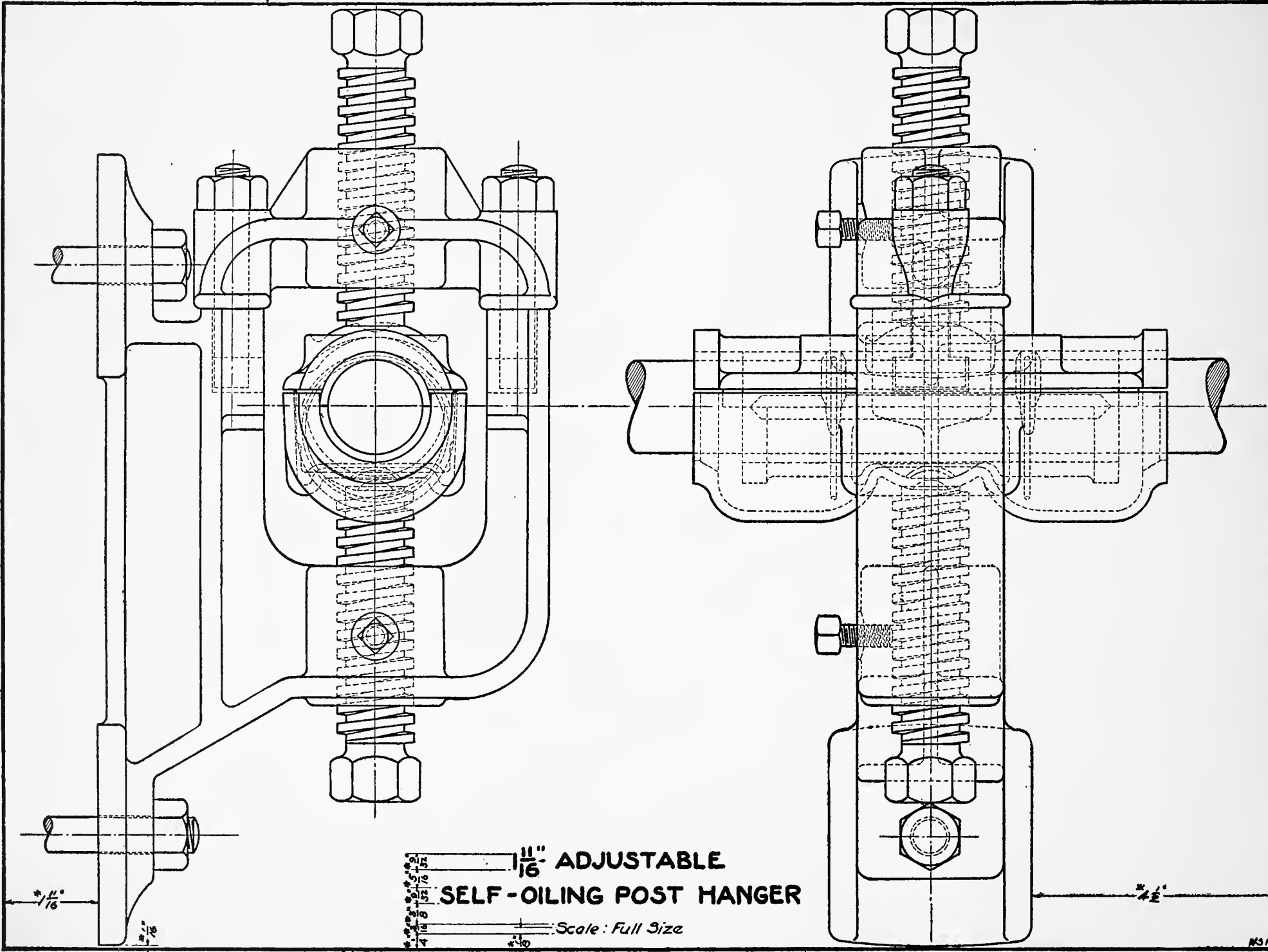

**1 11/16" ADJUSTABLE  
SELF-OILING POST HANGER**  
Scale: Full Size

\*Dimensions Are Not To Appear on Student's Plate

JULY 15, 1912

WHITMORE . J.B. - CE - 1-DR. 21.

N3H



OCT 26 1912





LIBRARY OF CONGRESS



0 019 973 647 4