

# MACHINERY'S REFERENCE SERIES

EACH NUMBER IS A UNIT IN A SERIES ON ELECTRICAL AND  
STEAM ENGINEERING DRAWING AND MACHINE  
DESIGN AND SHOP PRACTICE

NUMBER 97

## OPERATION OF MACHINE TOOLS

By FRANKLIN D. JONES

SECOND EDITION

### MILLING MACHINES—PART II

#### CONTENTS

Compound Indexing—Differential Indexing	-	-	3
Cutting Spur Gears in a Milling Machine	-	-	11
Helical or Spiral Milling	-	-	16
The Vertical Milling Machine	-	-	31
Lincoln and Planer-type Milling Machines	-	-	43

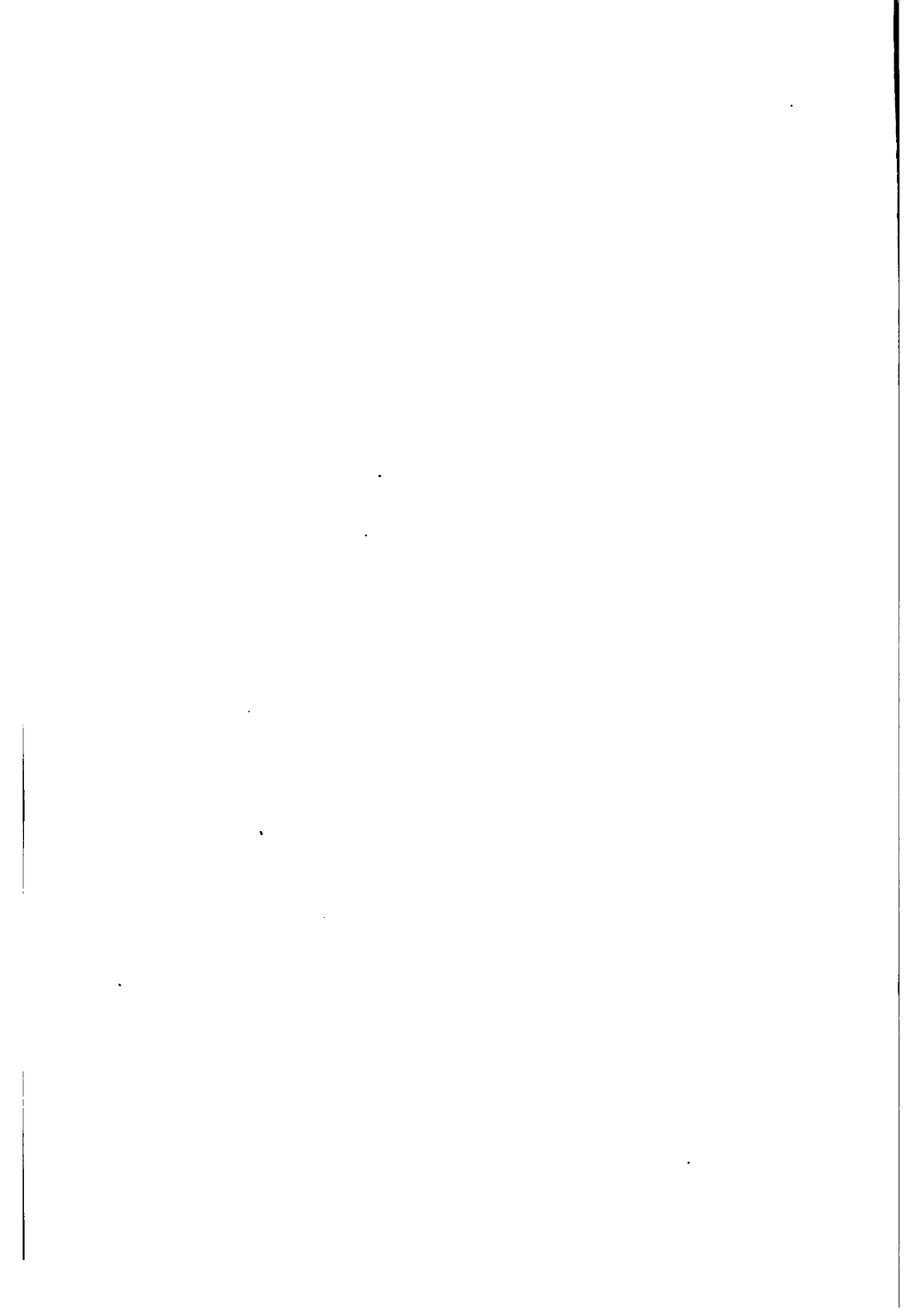

## CHAPTER I

### COMPOUND INDEXING—DIFFERENTIAL INDEXING

Ordinarily, the index crank of a spiral head must be rotated a fractional part of a revolution, when indexing, even though one or more complete turns are required. As explained in Part I of this treatise, this fractional part of a turn is measured by moving the latch-pin a certain number of holes in one of the index circles; but occasionally, none of the index plates furnished with the machine, has circles of holes containing the necessary number for obtaining a certain division. One method of indexing for divisions which are beyond the range of those secured by the direct method, is to first turn the crank a definite amount in the regular way, and then the index plate itself, in order to locate the crank in the proper position. This is known as compound indexing, because there are two separate movements which are, in reality, two simple indexing operations. The index plate is normally kept from turning, by a stationary stop-pin at the rear, which engages one of the index holes, the same as the latch-pin. When this stop-pin is withdrawn, the index plate can be turned.

To illustrate the principle of the compound method, suppose the latch-pin is turned one hole in the 19-hole circle and the index plate is also moved one hole in the 20-hole circle and in the same direction that the crank is turned. These combined movements will cause the worm (which engages the worm-wheel on the spiral head spindle)

to rotate a distance equal to  $\frac{1}{19} + \frac{1}{20} = \frac{39}{380}$  of a revolution. On the other

hand, if the crank is moved one hole in the 19-hole circle, as before, and the index plate is moved one hole in the 20-hole circle, *but in the*

*opposite direction*, the rotation of the worm will equal  $\frac{1}{19} - \frac{1}{20} = \frac{1}{380}$

revolution. By the simple method of indexing, it would be necessary to use a circle having 380 holes to obtain these movements, but by rotating both the index plate and crank the proper amount, either in the same or opposite directions, as may be required, it is possible to secure divisions beyond the range of the simple or direct system.

To illustrate the use of the compound method, suppose 69 divisions were required. In order to index the work  $\frac{1}{69}$  revolution, it is necessary

to move the crank  $\frac{40}{69}$  of a turn ( $40 \div 69 = \frac{40}{69} = \frac{40}{1} \times \frac{1}{69} = \frac{40}{69}$ ), and this

would require a circle having 69 holes, if the simple method of indexing were employed, but by the compound system, this division can be

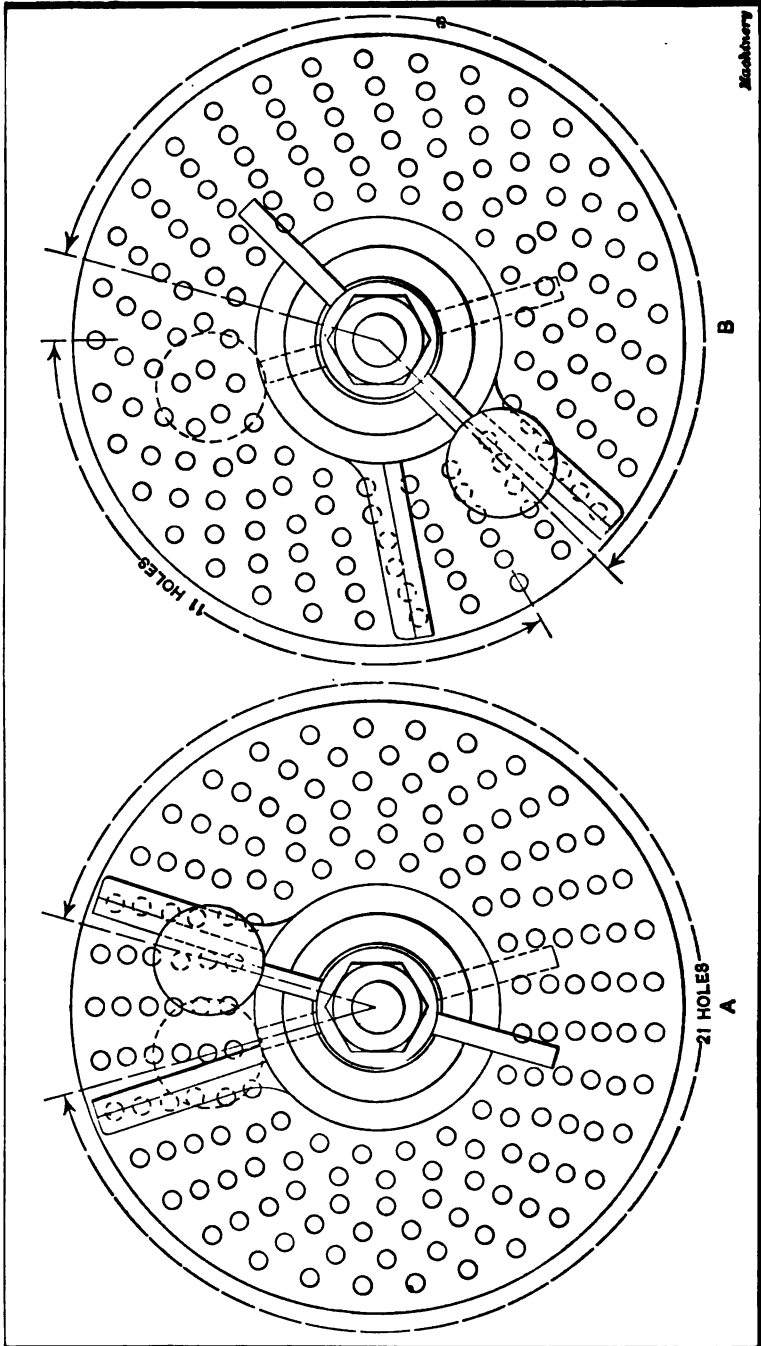

Fig. 1. Diagrams illustrating the Principle of Compound Indexing

obtained by using the 23- and 33-hole circles, which are found on one of the three standard plates furnished with Brown & Sharpe spiral heads. The method of indexing  $\frac{1}{69}$  revolution by the compound system

is as follows: The crank is first moved to the right 21 holes in the 23-hole circle, as indicated at *A* in Fig. 1 and it is left in this position; then the stop-pin at the rear, which engages the 33-hole circle of the index plate, is withdrawn, and the plate is turned backward, or to the left, 11 holes in the 33-hole circle. This rotation of the plate also carries the crank to the left, or from the position shown by the dotted lines at *B*, to that shown by the full lines, so that after turning the plate backward, the crank is moved from its original position a distance  $x$  which is equal to  $\frac{21}{23} - \frac{11}{33} = \frac{40}{69}$  which is the fractional part of a

turn the crank must make, in order to index the work  $\frac{1}{69}$  of a revolution.

One rule for determining what index circles can be used for indexing by the compound method, is as follows: Resolve into its factors the number of divisions required; then choose at random two circles of holes, subtract one from the other, and factor the difference. Place the two sets of factors thus obtained above a horizontal line. Next factor the number of turns of the crank required for one revolution of the spindle (or 40) and also the number of holes in each of the chosen circles. Place the three sets of factors thus obtained below the horizontal line. If all the factors above the line can be cancelled by those below, the two circles chosen will give the required number of divisions; if not, other circles are chosen and another trial made.

To illustrate this rule by using the example given in the foregoing, we have:

$$\begin{array}{r}
 69 = 3 \times 23 \\
 33 - 23 = 10 = 2 \times 5 \\
 \hline
 40 = 2 \times 2 \times 2 \times 5 \\
 33 = 3 \times 11 \\
 23 = 23 \times 1
 \end{array}$$

As all the factors above the line cancel, we know that the index plate having 23- and 33-hole circles can be used. The next thing to determine is how far to move the crank and the index plate. This is found by multiplying together all the uncanceled factors below the line; thus:

$2 \times 2 \times 11 = 44$ . This means that to index  $\frac{1}{69}$  of a revolution, the

crank is turned *forward* 44 holes in the 23-hole circle, and the index plate is moved *backward* 44 holes in the 33-hole circle. The movement can also be forward 44 holes in the 33-hole circle and backward 44 holes in the 23-hole circle, without affecting the result. The move-

ments obtained by the foregoing rule are expressed in compound indexing tables in the form of fractions, as for example:  $+\frac{44}{23}-\frac{44}{33}$ . The

numerators represent the number of holes indexed and the denominators the circles used, whereas, the + and - signs show that the movements of the crank and index plate are opposite in direction. These fractions can often be reduced and simplified so that it will not be necessary to move so many holes, by adding some number to them algebraically. The number is chosen by trial, and its sign should be opposite that of the fraction to which it is added. Suppose, for example, we add a fraction representing one complete turn, to each of the fractions referred to; we then have:

$$\begin{array}{r}
 +\frac{44}{23}-\frac{44}{33} \\
 -\frac{23}{23}+\frac{33}{33} \\
 \hline
 +\frac{21}{23}-\frac{11}{33}
 \end{array}$$

If the indexing is governed by these simplified fractions, the crank is moved forward 21 holes in the 23-hole circle and the plate is turned backward 11 holes in the 33-hole circle, instead of moving 44 holes, as stated. The result is the same in each case, but the smaller movements are desirable, especially for the index plate, because it is easier to count 11 holes than 44 holes. For this reason, the fractions given in index tables are simplified in this way. Ordinarily, the number of circles to use and the required number of movements to make when indexing, is determined by referring to a table as this eliminates all calculations, and lessens the chance of error.

Sometimes the simple method of indexing can be used to advantage in conjunction with the compound system. For example, if we want to cut a 96-tooth gear, every other tooth can be cut first by using the simple method and indexing for 48 teeth, which would require a movement of 15 holes in an 18-hole circle. When half of the tooth spaces

have been cut, the work is indexed  $\frac{1}{96}$  of a revolution by the compound

method, for locating the cutter midway between the spaces previously milled. The remaining spaces are then finished by again indexing for 48 divisions by the simple system.

Compound indexing should only be used when necessary, because of the chances of error, owing to the fact that the holes must be counted when moving the index plate. As previously explained, the number of holes that the crank is turned, is gaged by a sector. This counting also requires considerable time and, because of these disadvantages, the compound system is not used to any great extent; in fact, the more

modern spiral heads are so arranged that divisions formerly obtained by this system, can now be secured in a more simple and direct way.

### Differential Indexing

One of the improved indexing systems, which is applied to the universal milling machines built by the Brown & Sharpe Mfg. Co., is

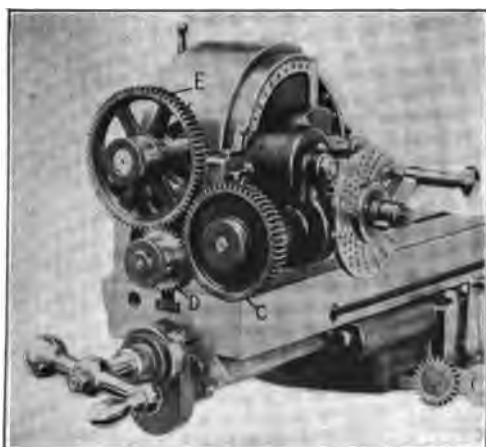

Fig. 2. Index Head geared for Differential Indexing

known as the differential method. This system is the same in principle as compound indexing, but differs from the latter in that the index plate is rotated by suitable gearing which connects it to the spiral-head spindle, as shown in Figs. 2 and 3. This rotation or differential motion of the index plate takes place when the crank is turned, the plate moving either in the same direction as the crank or opposite to it,

as may be required. The result is that the *actual* movement of the crank, at every indexing, is either greater or less than its movement with relation to the index plate. This method of turning the index plate by gearing instead of by hand, makes it possible to obtain any division liable to arise in practice, by using one circle of holes and simply turning the index crank in one direction, the same as for plain indexing. As the hand movement of the plate and the counting of holes is eliminated, the chances of error are also greatly reduced.

The proper sized gears to use for moving the index plate the required amount, would ordinarily be determined by referring to a table which accompanies the machine. This table (a

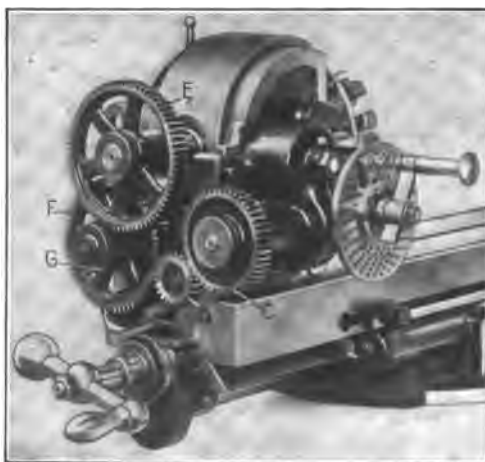

Fig. 3. Index Head equipped with Compound Gearing for Differential Indexing





reduced because the total movement of the crank, for each indexing, is equal to its movement relative to the index plate, *plus* the movement of the plate itself when (as in this case) the crank and plate rotate in the same direction. If they were rotated in opposite directions, the crank would have a total movement equal to the amount it turned relative to the plate, *minus* the plate's movement.

Sometimes it is necessary to use compound gearing, in order to move the index plate the required amount for each turn of the crank. Fig. 3 shows a spiral head equipped with compound gearing for obtaining 319 divisions. The gears given in the table are as follows: Gear *O* on the worm, 48 teeth; first gear *F* placed on the stud, 64 teeth; second gear *G* on the stud, 24 teeth; gear *E* on the spindle, 72 teeth; and one idler gear *D*, having 24 teeth.

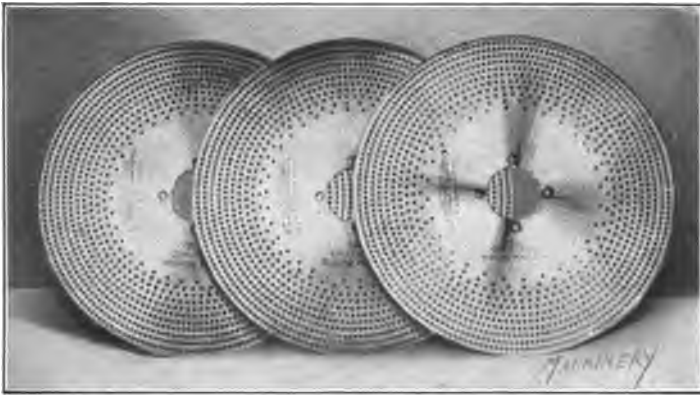

Fig. 5. Index Plates for obtaining a Large Number of Divisions by Simple Indexing

The following example is given to illustrate the method of determining the index movements and change gears to use for differential indexing: Suppose 59 divisions were required, what circle of holes and gears should be used? First assume that we are to index for 60

divisions by the simple method, which would require a  $\frac{2}{3}$  movement

of the crank. Now, if the crank is indexed  $\frac{2}{3}$  of a revolution, 59 times,

it will rotate in all,  $59 \times \frac{2}{3}$  or  $39 \frac{1}{3}$  revolutions, which is  $\frac{2}{3}$  of a revolution less than the 40 required for one complete revolution of the work. Therefore, the index plate must be geared so that it will move forward  $\frac{2}{3}$  of a turn, while the work is revolving once. Hence, the

ratio of the gearing must be  $\frac{2}{3}$  to 1. Gears are next selected from those

provided with the machine, which will give this ratio, as for example, gears having 32 and 48 teeth, respectively. The small gear is placed on the spindle, in this case, because the index plate is to make only  $\frac{2}{3}$  of a turn, while the spindle makes one complete revolution. One idler gear is also interposed between the gears, because it is necessary for the plate to gain  $\frac{2}{3}$  of a turn with respect to the crank; therefore, the movements of the index plate and crank must be in the same direction.

The differential method cannot be used for helical or spiral milling, because the spiral-head is then geared to the lead-screw of the machine, as explained in Chapter III.

#### High-number, Reversible Index Plates

The dividing heads furnished with Cincinnati milling machines, are equipped with comparatively large index plates. This increase in diameter gives room for more circles and a larger number of holes than the smaller plates, and the range is further increased by making the plate reversible, each side having different series of holes. Therefore, the number of divisions that can be obtained directly from one of these plates is greatly increased. The standard plate regularly supplied can be used for indexing all numbers up to 60; all even numbers and those divisible by 5 up to 120, and many other divisions between 120 and 400. If it should be necessary to index high numbers not obtainable with the standard plate, a high number indexing attachment can be supplied. This consists of three special plates (see Fig. 5), which have large numbers of holes and different series on each side. They can be used for indexing all numbers up to and including 200; all even numbers and those divisible by 5 up to and including 400. Owing to the range of the standard plate, the high-number attachment is only needed in rare instances, for ordinary milling machine work.

## CHAPTER II

### CUTTING SPUR GEARS IN A MILLING MACHINE

Spur gears are ordinarily cut in special gear-cutting machines, but the milling machine is often used in shops not equipped with special machines, or for cutting gears of odd sizes, especially when only a small number are required. Fig. 6 illustrates how a small spur gear is cut in the milling machine. The gear blank is first bored and turned to the correct outside diameter and then it is mounted on an arbor which is placed between the centers of the dividing head. An arbor having a taper shank which fits the dividing-head spindle, is a good form to use for gear work. If an ordinary arbor with centers in both ends is employed, all play between the driving dog and faceplate should be taken up to insure accurate indexing.

#### Cutter for Spur Gears

The type of cutter that is used for milling the teeth of spur gears, is shown in Fig. 7. This style of cutter is manufactured in various sizes for gears of different pitch. The teeth of these cutters have the same shape or profile as the tooth spaces of a gear of corresponding pitch; therefore, the cutter to use depends upon the pitch of the gear to be cut. The number of teeth in the gear must also be considered, because the shape or profile of the teeth of a small gear is not exactly the same as that of the teeth of a large gear of corresponding pitch.

The cutters manufactured by the Brown & Sharpe Mfg. Co. for cutting gears according to the involute system, are made in eight different sizes for each pitch. These cutters are numbered from 1 to 8 and the different numbers are adapted for gears of the following sizes. Cutter No. 1, for gears having teeth varying from 135 to a rack; No. 2, gears with from 55 to 134 teeth; No. 3, from 35 to 54 teeth; No. 4, from 26 to 34 teeth; No. 5, from 21 to 25 teeth; No. 6, from 17 to 20 teeth; No. 7, from 14 to 16 teeth; and No. 8, from 12 to 13 teeth.

If we assume that the diametral pitch of the gear illustrated in Fig. 6 is 12 and the required number of teeth, 90, a No. 2 cutter of 12 diametral pitch would be used, the No. 2 shape being selected because it is intended for all gears having teeth varying from 55 to 134.

#### Setting the Cutter Central

After the cutter is mounted on an arbor, it must be set over the center of the gear blank, as otherwise the teeth will not be milled to the correct form. One method of centering the cutter is illustrated by the diagram, Fig. 8. A true arbor is placed between the dividing head and foot-stock centers, and the table of the machine is first adjusted to locate the arbor in any convenient position outside of and somewhat below the cutter as at A. The graduated dial of the cross-

feed screw is next set to zero. The arbor is then moved to position *B* and it is adjusted to barely touch or pinch a thin tissue paper "feeler" *f* held between the arbor and the corner of the cutter. The dial of the elevating screw is now set at zero, and the horizontal distance between positions *A* and *B* should be noted by referring to the cross-feed dial. For convenience, this will be called dimension No. 1, as indicated by the illustration. The arbor is next lowered and returned to position *A*, horizontally, the vertical position not being particular. The arbor is then raised until the elevating screw dial is again at zero, after

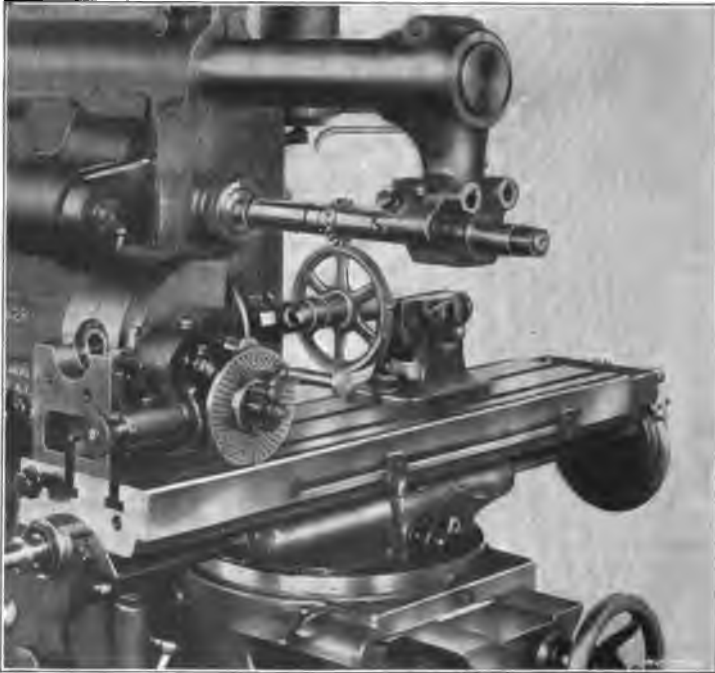

Fig. 6. Cutting the Teeth of a Spur Gear in a Universal Milling Machine

which it is moved to position *C*, or until it just touches a tissue paper "feeler" as before. The horizontal dimension No. 2 is next noted by referring to the cross-feed dial; this is added to dimension No. 1 and the sum is divided by 2 to get dimension No. 3. The arbor is then returned to position *A* (as far as the horizontal location is concerned) after which it is lowered far enough to clear the cutter and then moved inward a distance equal to dimension No. 3, which is the central position. This operation can be performed more quickly than described. When making the adjustments, all dial readings should be taken at the end of the inward or upward movements, to avoid errors due to backlash or lost motion in the elevating or feed screws.

A method of testing the location of a gear cutter, when considerable accuracy is required, is as follows: First mill a tooth space in a

trial blank having the same diameter as the gear blank, and then, without changing the position of the cutter, remove the blank from the work arbor and turn it end for end. The blank should be loose on the arbor to permit feeding it back so that the cutter will enter the tooth space previously milled. The cutter is then revolved slowly by hand, in order to mark its position in the slot. If it is set exactly central, the second cut will follow the first, but if it is not central, some metal will be removed from the top of the space on one side and the bottom on the other. In order to center the cutter, it should be moved laterally toward that side of the tooth from which stock was milled at the top. Another trial cut is then taken and the test repeated.

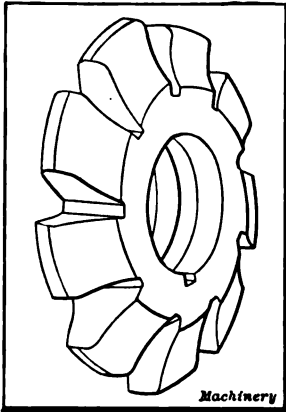

Fig. 7. Cutter for Milling the Teeth of Spur Gears

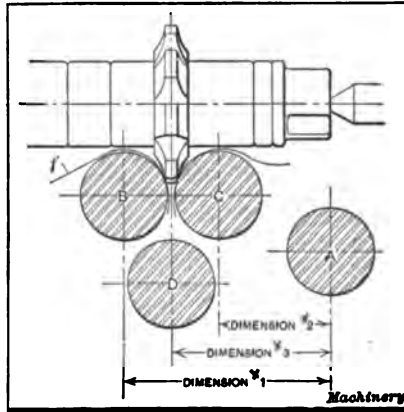

Fig. 8. Method of setting Cutter Central with Arbor

When the cutter is centrally located, the saddle should be clamped to the knee to hold it rigidly in position.

#### Setting the Cutter to Depth—Milling the Teeth

The next step is to set the cutter for milling tooth spaces of the proper depth. If the outside diameter of the gear blank is accurate, this can be done by first adjusting the blank upward until the revolving cutter just grazes its surface. The dial of the elevating screw is then set at zero, after which the blank is moved horizontally, to clear the cutter, and then vertically the required amount, as shown by the micrometer dial. This vertical adjustment should equal the total depth of the tooth space, which can be found by dividing the constant 2.157 by the diametral pitch of the gear. For example, if the diametral pitch

is 12, the depth of the tooth space =  $\frac{2.157}{12} = 0.179$  inch. After the

blank has been raised this amount, the gear teeth are formed by feeding the blank horizontally and indexing after each tooth space is milled. About one quarter of the teeth have been milled in the gear blank shown in Fig. 6. The accuracy of the gear, assuming that the

cutter is properly made, will depend largely upon setting the cutter central and to the proper depth. When the depth is gaged from the outside of the blank, the diameter of the latter should be accurate, as otherwise the teeth will not have the correct thickness. This diameter can be found by adding 2 to the number of teeth and dividing by the diametral pitch. The special vernier, gear-tooth caliper shown in Fig. 9, is sometimes used for testing the thickness of the first tooth milled. This test is especially desirable if there is any doubt about the accuracy of the outside diameter. A trial cut is taken at one side of the blank and then the work is indexed for the next space, after

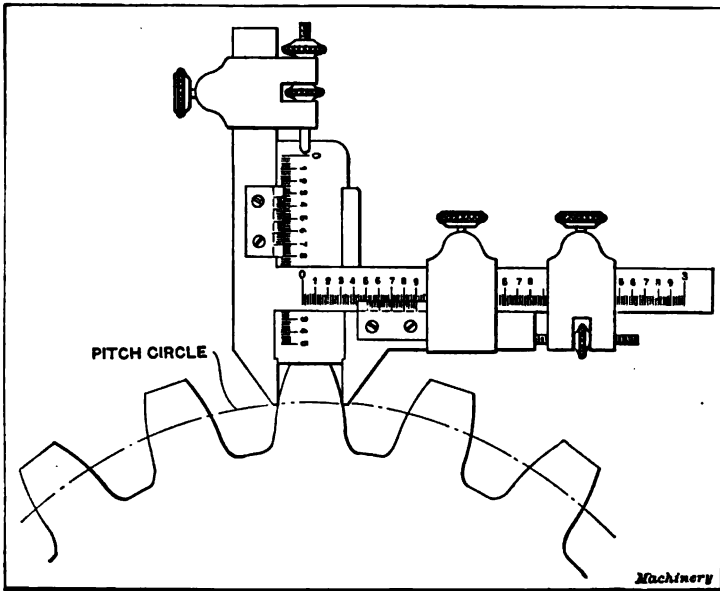

Fig. 9. Vernier Caliper for measuring the Thickness of Gear Tooth at the Pitch Circle

which another trial cut is taken part way across the gear. The vertical scale of the caliper is then set so that when it rests on top of the tooth (as shown in the illustration), the lower ends of the caliper jaws will be at the height of the pitch line. The horizontal scale then shows the thickness of the tooth at this point. The height from the top of the tooth to the pitch line equals the circular pitch multiplied by the constant 0.3183. The thickness of the tooth at the pitch line, for any gear, can be determined by dividing the circular pitch by 2, or the constant 1.57 by the diametral pitch. With a diametral pitch of 12,

the thickness would equal  $\frac{1.57}{12} = 0.131$  inch. The two trial cuts for

determining the tooth thickness, should not extend across the blank, as it is better to simply gash one side; then if an adjustment is necessary, all the tooth spaces will be milled from the solid; whereas, if

trial cuts were taken clear across the blank, very little metal would be removed from these spaces by the final cut and the thickness of the tooth between them would differ somewhat from the other teeth in the gear.

When a gear tooth is measured as shown in Fig. 9 it is the chordal thickness  $T$  (see Fig. 9a) that is obtained, instead of the thickness along the pitch circle; hence when measuring teeth of coarse pitch, especially if the diameter of the gear is quite small, dimension  $T$  should be obtained if accuracy is required. It is also necessary to find the height  $x$  of the arc and add it to the addendum  $H$  to get the corrected height  $H_1$ , in order to measure the chordal thickness  $T$  at the proper point on the sides of the tooth.

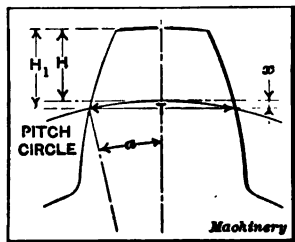

Fig. 9a. When measuring Large Gear Teeth, the Chordal Thickness  $T$  should be determined

To determine dimension  $T$ , multiply the pitch diameter of the gear by the sine of the angle  $\alpha$  between the center and radial lines shown. Expressing this as a formula we have  $T = D \sin \alpha$ , in which  $D$  equals the pitch diameter. To find angle  $\alpha$ , divide 90 degrees by the number of teeth in the gear. The height  $x$  of the arc is found as follows:  $x = R(1 - \cos \alpha)$ , in which  $R$  equals the pitch radius. That is,  $x$  equals 1 minus the cosine of angle  $\alpha$  multiplied by the pitch radius of the gear. The corrected height  $H_1$  is

found by adding  $x$  to the distance  $H$  from the top of the tooth to the pitch circle. If much gear cutting is done, it is well to secure a table giving the chordal thickness  $T$  and the corrected height  $H_1$ , for various pitches and numbers of teeth.

When milling the teeth, a space is cut by feeding the blank in such a direction that it moves against the rotation of the cutter. After a space is milled, the cutter is returned to its starting point and the

blank is indexed  $\frac{1}{90}$  of a revolution (as the gear is to have 90 teeth)

for milling the next space. This operation is repeated until all the teeth are milled.

When milling gear teeth that are coarser than 6 or 7 diametral pitch, it is advisable to first rough mill all the teeth and then take finishing cuts. Special "stocking" cutters are often used for rough milling very coarse gears, preparatory to finishing by a regular cutter. The speed for cutting gear teeth depends on the pitch of the teeth, the kind of material being milled, and the rigidity of the work and machine.

When the diameter of a gear is referred to, it is understood to mean the pitch diameter or diameter of the pitch circle, and not the outside diameter. The diametral pitch is the number of teeth to each inch of pitch diameter, and the circular pitch is the distance from the center of one tooth to the center of the next, measured along the pitch line.

## CHAPTER III

### HELICAL OR SPIRAL MILLING

The spiral head is not only used for indexing or dividing, but also in connection with the milling of spiral grooves. When a spiral is being milled, the work is turned slowly by the dividing head as the table of the machine feeds lengthwise. As the result of these combined movements, a spiral groove is generated by the milling cutter. The principle of spiral milling, is illustrated by the diagrams shown in Fig. 10. If a cylindrical part mounted between centers, as at *A*, is rotated and, at the same time, moved longitudinally at a constant rate, past a revolving cutter *c*, a helical or spiral groove will be milled as indicated by the curved line. Strictly speaking, a curve generated in this way upon a cylindrical surface, is a helix and not a spiral, although such curves will be referred to as spirals in this treatise, because of the universal use of this term at the present time.

Evidently, the lead *l* or distance that this spiral advances in one revolution, will depend upon the ratio between the speed of rotation and the longitudinal feeding movement. If the speed of rotation is increased, the lead of the spiral will be diminished, and *vice versa*, provided the rate of the lengthwise travel remains the same. If the cylinder traverses a distance equal to its length while making one revolution, the dimension *l* (sketch *A*) would equal the lead of the spiral generated, but, if the speed of rotation were doubled, the lead *l*, (sketch *B*), would be reduced one-half (assuming that the rate of lengthwise movement is the same in each case), because the cylinder would then make two revolutions while traversing a distance equal to its length.

#### Change Gears for Spiral Milling

The method of varying the speed of rotation on a milling machine, for obtaining spirals of different leads, will be seen by referring to Fig. 11 which shows an end and side view of a spiral head mounted on the table of the machine and arranged for spiral milling. The rotary movement of the spindle *S* and the work, is obtained from the feed-screw *L*, which also moves the table longitudinally. This feed-screw is connected to shaft *W* by a compound train of gears; *a*, *b*, *c* and *d*, and the movement is transmitted from shaft *W* to the worm-shaft (which carries the indexing crank) through the spiral gears *e*, *f*, and spur gearing (not shown) which drives the index plate, crank, and worm-shaft. When a spiral is to be milled, the work is usually placed between the centers of the spiral head and foot stock, and change gears *a*, *b*, *c* and *d* are selected to rotate the work at whatever speed is needed to produce a spiral of the required lead. The proper gears to use for obtaining a spiral of given lead, are ordinarily determined



by referring to a table which accompanies the machine, although the gear sizes can easily be calculated, as will be explained later.

As an example of spiral milling, suppose we have a cylindrical cutter blank  $3\frac{1}{4}$  inches in diameter in which right-hand spiral teeth are to be milled, as indicated in Fig. 12, which shows the cutter after the teeth have been milled. The blank is first mounted on an arbor which is placed between the centers with a driving dog attached. The arbor should fit tightly into the hole of the blank so that both will rotate as one piece, and it is also necessary to take up all play between the driving dog and faceplate. The spiral head is next geared to the feed-screw. If a table of change gears is available, it will show what gears

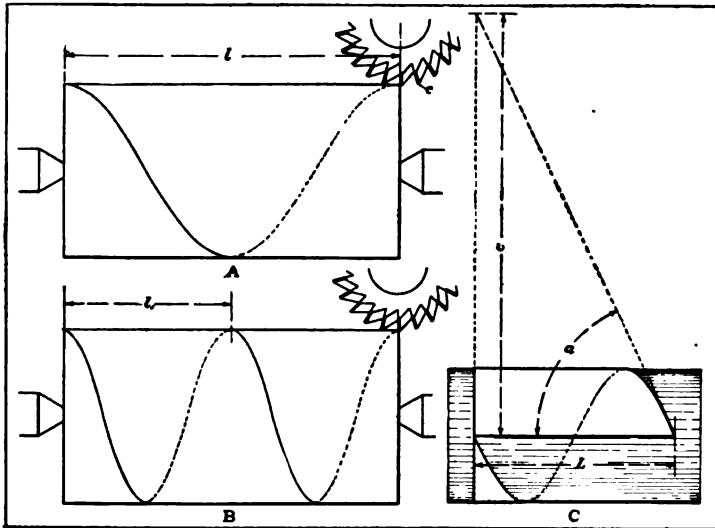

Fig. 10. Diagrams illustrating the Principle of Helical or Spiral Milling

are needed, provided the lead of the spiral is known. A small section of one of these tables is reproduced herewith (see Fig. 13) to illustrate the arrangement. Suppose the lead given on the drawing is 48 inches; then this figure (or the nearest one to it) is found in the column headed, "Lead in Inches," and the four numbers to the right of and in line with 48, indicate the number of teeth in the four gears to be used. The numbers opposite 48 are 72, 24, 64 and 40, respectively, and the position for each of these gears is shown by the headings above the columns. As 72 is in the column headed "Gear on Worm," a gear *d* (see also Fig. 11) of this size is placed on shaft *W*. The latter is referred to as the "worm-shaft," although, strictly speaking, the worm-shaft *W*, is the one which carries the indexing crank and worm. The first gear *c* placed on the stud *E*, has 24 teeth, as shown by the table, and the second gear *b* on the same stud has 64 teeth, whereas gear *a* on the screw has 40 teeth.

After these gears are placed in their respective positions, the first

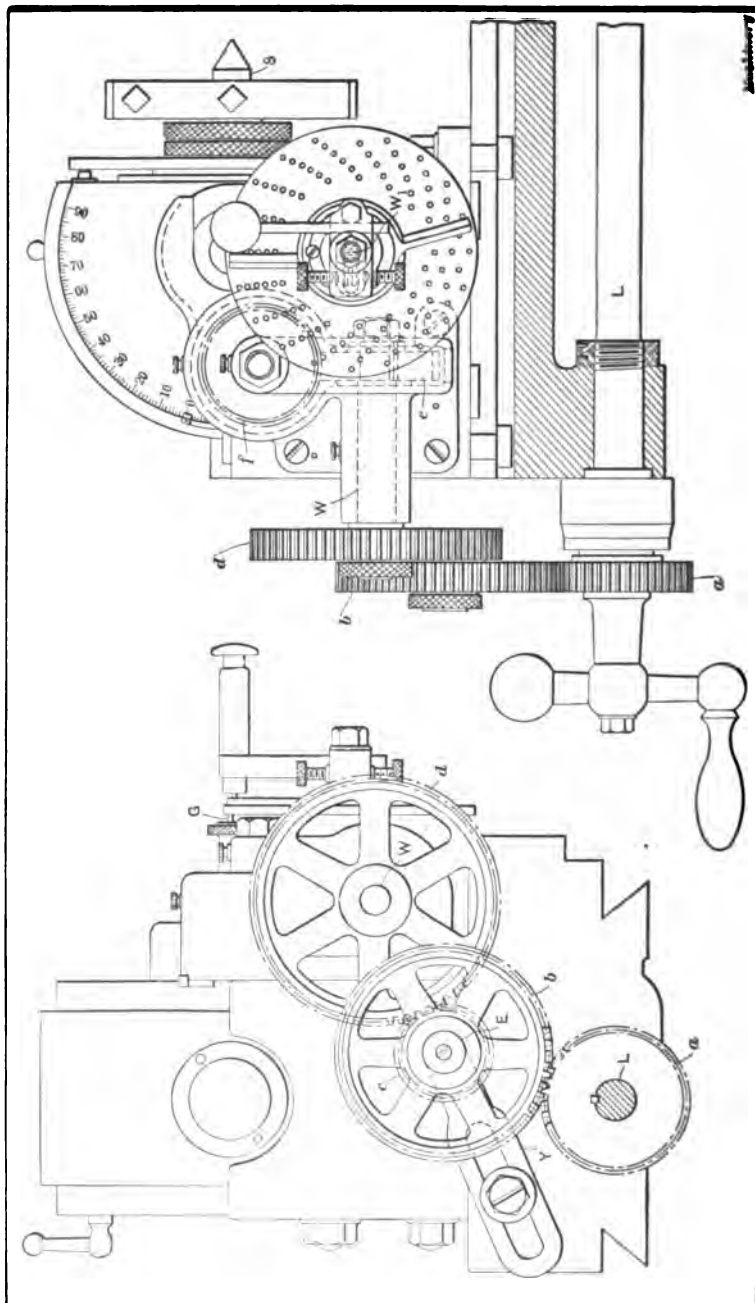

Fig. 11. The Indexing or Spiral Head of a Universal Milling Machine

and second gears *c* and *b* on stud *E* are adjusted to mesh properly with gears *a* and *d* by changing the position of the supporting yoke *Y*. As a right-hand spiral is to be milled, which means that it advances by twisting or turning to the right, an idler gear is not used with the design of spiral head shown. When milling a left-hand spiral, it is necessary to insert an idler gear in the train of gears (as at *j* in Fig. 17) in order to rotate the work in a reverse direction; this idler has no effect, however, on the ratio of the gearing. When the change gears are in place, evidently any longitudinal movement of the table effected by turning feed-screw *L*, will be accompanied by a rotary movement of the spiral head spindle. As connection is made with the worm-shaft *W*., Fig. 11, through the index plate and crank, the stop-pin *G* at the rear must be withdrawn for spiral milling, so that the index plate will be free to turn.

#### Form of Cutter Used and its Position

The next thing to consider is the kind of cutter to use. If we assume that the grooves are to have an angle of 60 degrees, evidently the cutter must have teeth which conform to this angle. The type used for forming teeth of spiral mills, is shown at *A* in Fig. 14. The teeth have an inclination with the axis, of 48 degrees on one side and 12 degrees on the other, thus giving an included angle of 60 degrees for the tooth spaces. This form of cutter is used in preference to the single-angle type shown at *B*, for milling spiral teeth, because the 12-degree side will clear the radial faces of the teeth and produce a smooth surface. The single-angle cutter *B* is used for milling grooves that are parallel with the axis. The cutter is mounted on an arbor, and it is set in such a position that when the groove is cut to the required depth, the 12-degree side will be on a radial line, as shown by the sketch; in other words, it should be set so that the front faces of the teeth to be milled, will be radial.

#### Setting the Cutter

A method of setting a double-angle cutter, for milling the teeth in spiral mills, which is simple and does not require any calculations, is, as follows: The pointer of a surface gage is first set to the height of the index head center and then the work is placed in the machine. The cutter is next centered with the blank, laterally, which can be done with a fair degree of accuracy by setting the knee to the lowest position at which the cutter will just graze the blank. The blank is then adjusted endwise until the axis of the cutter is in line with the end of the work, as shown by the side and plan views at *A*, Fig. 15. One method of locating the cutter in this position (after it has been set approximately) is to scribe a line on the blank, a distance from the end equal to the radius of the cutter. The blade of a square is then set to this line, and the table is adjusted lengthwise until the cutter just touches the edge of the blade. The cutter can also be centered with end (after it is set laterally) by first moving the blank endwise from beneath the cutter, and then feeding it back slowly until a tissue

paper "feeler" shows that it just touches the corner of the blank. The relation between the cutter and blank will then be as shown at *A*.

The table is next set to the angle of the spiral (as explained later) but its lengthwise position should not be changed. The surface gage, set as previously described, is then used to scribe lines which represent one of the tooth spaces on the end of the blank where the cut is to start. This is done by first drawing a horizontal line as at *B*. This line is then indexed downward an amount equal to one of the tooth

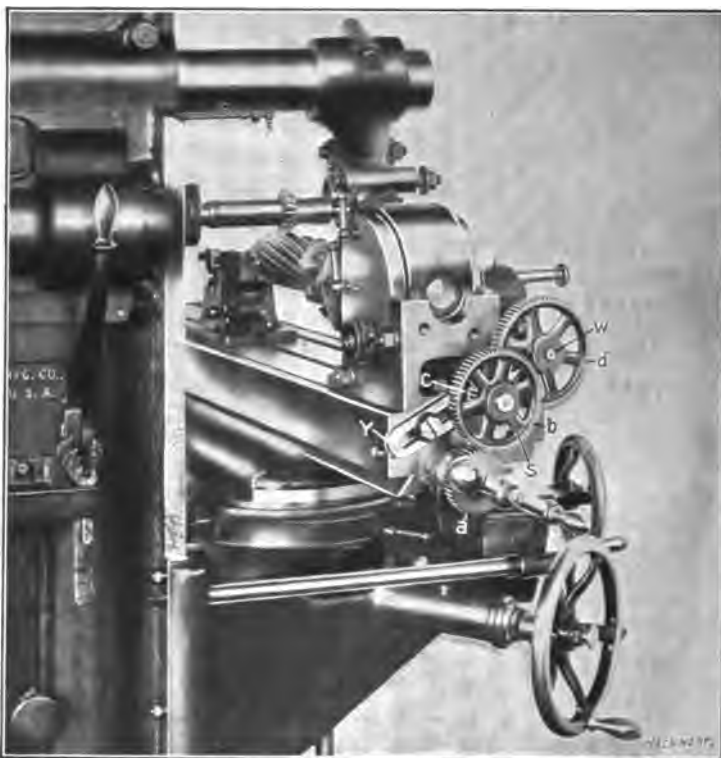

Fig. 12. Universal Machine arranged for Spiral Milling

spaces, and another horizontal line is drawn as at *C*. The last line scribed is then indexed  $90 + 12$  degrees, which locates it parallel with the 12-degree side of the cutter, as at *D*. The work is then adjusted laterally, and vertically by elevating the knee, until the cutter is so located that the 12-degree side cuts close to the scribed line, and, at the same time, the required width of land *w* (see sketch *E*) is left between the top edge of the groove and the line representing the front face of the next tooth. After the cutter is centered, as at *A*, the longitudinal position of the blank should not be changed until the cutter is set as at *E*, because any lengthwise adjustment of the work would be accompanied by a rotary movement (as the spiral head is geared to

the table feed-screw) and the position of the lines on the end would be changed.

**Setting the Table to Angle of Spiral and Milling the Grooves**

The table of the machine must also be set to the same angle that the spiral grooves will make with the axis of the work. This is done by loosening the bolts which normally hold the saddle to the clamp-bed, and swinging the table around to the right position, as shown by the degree graduations on the base of the saddle. The reason for setting the work to this angle is to locate the cutter in line with the spiral grooves which are to be milled by it. If the cutter were not in line with the spiral, the shape of the grooves would not correspond with

	DRIVER	DRIVER	DRIVER	DRIVER		DRIVER	DRIVER	DRIVER	DRIVER		DRIVER	DRIVER	DRIVER	DRIVER
LEAD IN INCHES	GEAR ON WORM	GEAR ON STUD	GEAR ON STUD	GEAR ON SCREW	LEAD IN INCHES	GEAR ON WORM	GEAR ON STUD	GEAR ON STUD	GEAR ON SCREW	LEAD IN INCHES	GEAR ON WORM	GEAR ON STUD	GEAR ON STUD	GEAR ON SCREW
42.00	72	24	56	40	48.00	72	24	64	40	56.31	86	24	44	28
					48.38	86	32	72	40	57.14	100	28	64	40
42.23	86	28	44	32	48.61	100	24	56	48	57.30	100	24	44	32
42.66	100	28	86	72	48.61	100	24	28	24	57.33	86	24	64	40
42.78	56	24	44	24	48.86	100	40	86	44	58.33	100	24	56	40
42.86	100	28	48	40	48.89	64	24	44	24	58.44	100	28	72	44
42.86	72	24	40	28	49.11	100	28	44	32	58.64	86	24	72	44
43.00	86	32	64	40	49.14	86	28	64	40	59.53	100	24	40	28
43.00	86	28	56	40	49.27	86	24	44	32	59.72	86	24	40	24
43.00	86	24	48	40	49.77	100	24	86	72	60.00	72	24	64	32
43.64	72	24	64	44	50.00	100	28	56	40	60.00	72	24	56	28
43.75	100	32	56	40	50.00	100	24	48	40	60.00	72	24	48	24
43.98	86	32	72	44	50.00	72	24	40	24	60.61	100	24	64	44
44.44	64	24	40	24	50.00	100	32	64	40	61.08	100	32	86	44
44.64	100	28	40	32	50.17	86	24	56	40	61.43	86	28	64	32
44.68	86	28	64	44	50.26	86	28	72	44	61.43	86	24	48	28

Fig. 13. Part of Table showing Gear Combinations to use for obtaining Spirals of Different Lead

the shape of the cutter. The angle to which the table should be set, or the spiral angle, varies according to the diameter of the work and lead of the spiral. As the diameter, in this case, is 3 1/4 inches and the lead of the spiral is 48 inches, the angle is 12 degrees. The direction in which the table is turned, depends upon whether the spiral is right- or left-hand. For a right-hand spiral the right-hand end of the table should be moved toward the rear, whereas if the spiral is left-hand, the left-hand end of the table is moved toward the rear.

After the table of the machine is set to the required angle and the saddle is clamped in position, the work is ready to be milled. The actual milling of the spiral grooves is practically the same as though they were straight or parallel to the axis. When a groove is milled, it is well to either lower the table slightly or turn the cutter to such a position that the teeth will not drag over the work, when returning for another cut, to prevent scoring or marring the finished groove. If the work-table is lowered, it is returned to its original position by referring

to the dial on the elevating screw. After each successive groove is cut, the work is indexed by turning the indexing crank in the regular way. This operation of milling a groove and indexing, is repeated until all the teeth are finished. It should be mentioned that the differential method of indexing cannot be employed in connection with spiral work, because with this system of indexing, the worm-shaft of the spiral head is geared to the spindle. When milling spiral grooves, the position of the cutter with relation to the work, should be such that the rotary movement for producing the spiral, will be toward that side of the cutter which has the greater angle. To illustrate, the blank *A*, Fig. 14, should turn (as shown by the arrow) toward the 48-degree side of the cutter, as this tends to produce a smoother groove.

#### Calculating Change-gears for Spiral Milling

As was explained in connection with Fig. 10, the lead of a spiral cut in a milling machine depends on the relation between the rotary speed

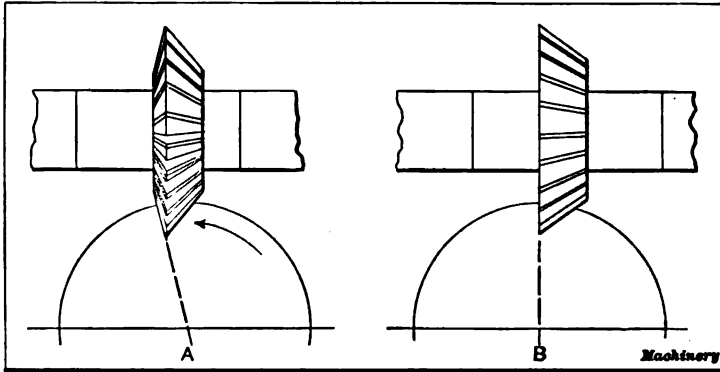

Fig. 14. Double- and Single-angle Cutters

of the work and its longitudinal movement, and these relative speeds are controlled by the change-gears *a*, *b*, *c* and *d*, Fig. 11, which connect the table feed-screw *L* with shaft *W*. If the combination of change-gears is such that 20 turns of screw *L* are required for one revolution of spindle *S*, and the screw has four threads per inch, the table will advance a distance equal to  $20 \div 4 = 5$  inches, which is the lead of the spiral obtained with that particular gearing. Now the proper gears to use for producing a spiral of any given lead, can easily be determined if we know what lead will be obtained when change-gears of equal diameter are used. Suppose gears of the same size are employed, so that feed-screw *L* and shaft *W* rotate at the same speed; then the feed-screw and worm-shaft *W*, will also rotate at the same speed, if the gearing which forms a part of the spiral head and connects shafts *W* and *W*, is in the ratio of one to one, which is the usual construction. As will be recalled, 40 turns of the worm-shaft are required for each revolution of spindle *S*; therefore with change-gears of the same diameter, the feed-screw will also make 40 turns, and assuming that it has

four threads per inch, the table movement will equal  $40 \div 4 = 10$  inches. This movement, then, of 10 inches, equals the lead of the spiral that would be obtained by using change-gears of the same size, and it is known as the *lead of the machine*.

If we wanted to mill a spiral having a lead of 12 inches and the lead of the machine is 10, the compound ratio of the gears required would be  $\frac{12}{10}$  or  $\frac{\text{lead of spiral}}{\text{lead of machine}}$ . The compound ratio, then, may be represented by a fraction having the lead of the required spiral as its numerator and the lead of the machine or 10 as its denominator. In

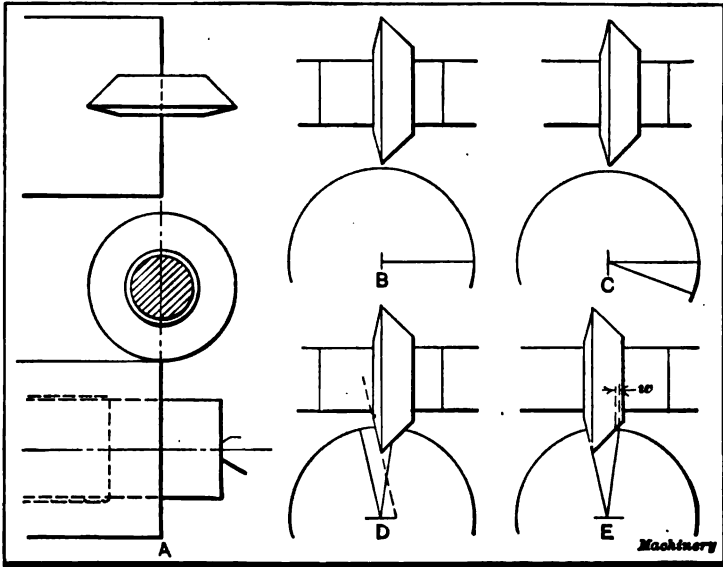

Fig. 15. Setting a Double-angle Cutter for Milling Teeth of a Spiral Mill

order to find what size gears to use, this ratio is revolved into two factors as follows:

$$\frac{12}{10} = \frac{3}{2} \times \frac{4}{5}$$

Each factor is then multiplied by some number which will give a numerator and denominator that corresponds to numbers of teeth on change-gears furnished with the machine. Suppose both terms of the first factor are multiplied by 24; we would then have,

$$\frac{3}{2} \times \frac{24}{24} = \frac{72}{48}$$

The second factor is also raised to higher terms in the same way; that is by using some multiplier which will give a new fraction, the numer-

ator and denominator of which equals the numbers of teeth in available gears. Suppose 8 is chosen for the second multiplier; we then have,

$$\frac{4}{5} \times \frac{8}{8} = \frac{32}{40}$$

The set of fractions obtained in this way, that is  $\frac{72}{48}$  and  $\frac{32}{40}$ , represent

the gears to use for milling a spiral having a lead of 12 inches. The numerators equal the number of teeth in the driven gears, and the denominators the number of teeth in the driving gears. If numbers occurred in either fraction which did not correspond with the number of teeth in any of the change-gears available, the fraction should be multiplied by some other trial number until the desired result is obtained.

#### Relative Positions of the Change-gears

When the gears for cutting a given spiral are known, it remains to place them in the proper place on the machine, and in order to do this, the distinction between *driving* and *driven* gears should be understood. The gear *a* (Fig. 11) on the feed-screw is a driver and gear *b*, which is rotated by it, is driven. Similarly, gear *c* is a driver and gear *d* is driven. As the numerators of the fractions represent driven gears, one having either 72 or 32 teeth (in this instance) should be placed on shaft *W*. Then a driving gear with either 40 or 48 teeth is placed on stud *E* and the remaining driven gear is afterwards mounted on the same stud. The other driving gear is next placed on the screw *L* and yoke *Y* is adjusted until the gears mesh properly. The spiral head will then be geared for a lead of 12 inches, the gear on the worm having 72 teeth, the first gear on the stud having 40 teeth, the second gear having 32 teeth, and the gear on the screw having 48 teeth. Either the driving or driven gears could be transposed without changing the lead of the spiral. For example, the driven gear with 32 teeth could be placed on shaft *W* and the one having 72 teeth could be used as a second gear on the stud, if such an arrangement were more convenient. As previously stated, a reverse or idler gear is inserted in the train when cutting left-hand spirals, but it does not affect the ratio of the gearing.

#### Determining the Angle of the Helix or Spiral

When the change-gears for a given spiral have been selected, the next step is to determine the angle to which the table of the machine must be set in order to bring the milling cutter in line with the spiral. This angle equals the angle that the spiral makes with its axis and it depends upon the lead of the spiral and the diameter of the cylindrical part to be milled. The angle of a spiral can be determined graphically by drawing a right-angle triangle as shown by sketch *C*, Fig. 10. If the length *e* of one side equals the circumference of the cylinder on which the spiral is to be generated, and the base *L* equals the lead, the angle *a* will be the spiral angle. If such a triangle is wrapped around



the cylinder, the hypotenuse will follow a helical curve, as the illustration indicates.

Another way of determining the angle of a spiral is to first get the tangent of the angle by dividing the circumference of the work by the lead of the spiral. When the tangent is known, the corresponding angle is found by referring to a table of natural tangents. For example, if the circumference  $c$  is 12 inches, and the lead  $L$  is 48 inches, the

tangent equals  $\frac{12}{48} = 0.25$  and the angle  $a$  corresponding to this tangent

is about 14 degrees. Evidently, if the circumference is increased or

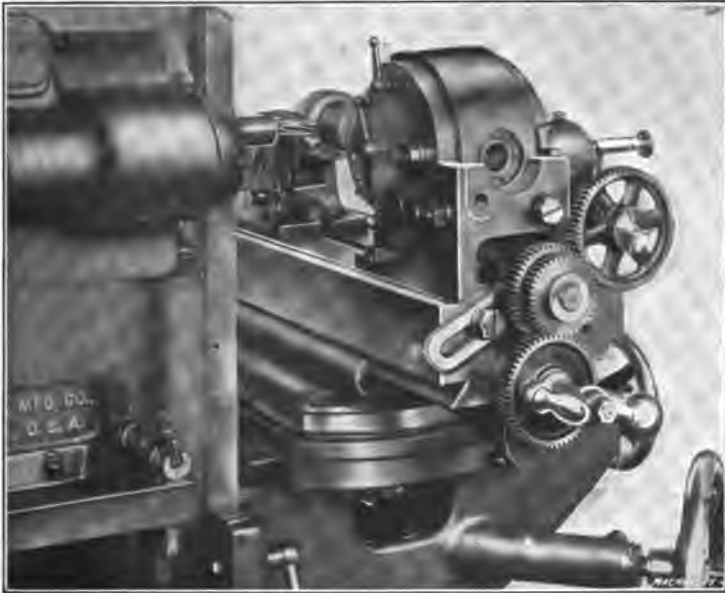

Fig. 16. Milling a Spiral Groove with an End Mill

diminished, there will be a corresponding change in angle  $a$  provided the lead  $L$  remains the same. For that reason, the outer circumference is not always taken when calculating the spiral angle. The angle for setting the table when cutting spiral gears in a milling machine, is determined by taking the diameter either at the pitch circle, or at some point between the pitch circle and the bottoms of the teeth, rather than the outside diameter, in order to secure teeth of the proper shape.

#### Cutting Spiral Grooves with an End Mill

When a spiral groove having parallel sides is required it should be cut with an end mill as illustrated in Fig. 16. If an attempt were made to mill a groove of this kind by using a side mill mounted on an arbor, the groove would not have parallel sides, because the side teeth of the mill would not clear the groove; in other words, they would cut away

the sides owing to the rotary movement of the work and form a groove having a greater width at the top than at the bottom. This can be overcome, however, by using an end mill. The machine is geared for the required lead of spiral, as previously explained, and the work is adjusted vertically until its axis is in the same horizontal plane as the center of the end mill. With the machine illustrated, this vertical adjustment can be obtained by moving the knee up until its top surface coincides

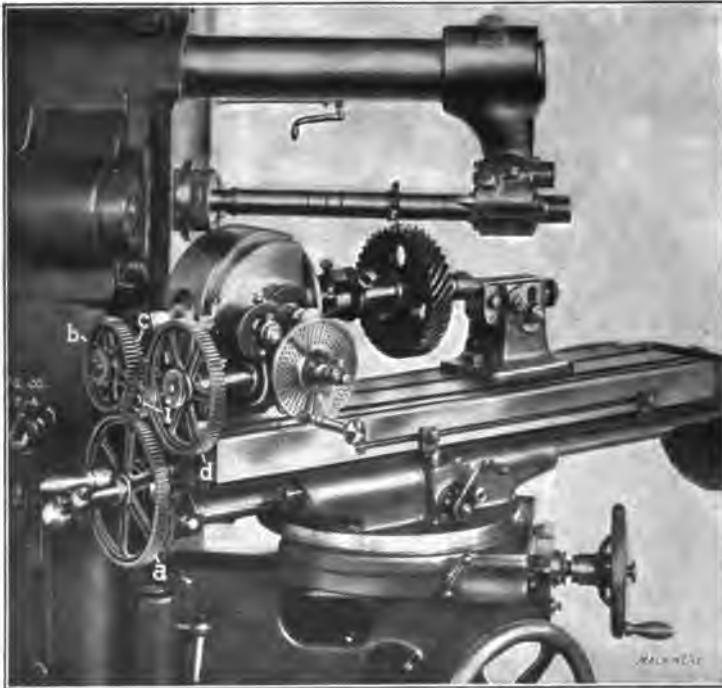

Fig. 17. Cutting the Teeth of a Spiral Gear in a Universal Milling Machine

with a line on the column marked *center*; the index head centers will then be at the same height as the axis of the machine spindle.

#### Cutting a Spiral Gear in a Universal Milling Machine

The teeth of spiral gears are often cut in universal milling machines, as indicated in Fig. 17, although special gear-cutting machines are used ordinarily where spiral gears are constantly being made, because the special machines are more efficient. As the teeth of a spiral gear are inclined to the axis and follow helical or "spiral" curves, they are formed by milling equally-spaced spiral grooves around the periphery of the blank, the number of the grooves corresponding, of course, to the number of teeth in the gear. From this it will be seen that a spiral gear is similar to a multiple-threaded screw, except that the teeth do not correspond in shape to screw threads; in fact, this type of gearing is sometimes referred to as screw gearing.

## Cutter to Use for Spiral Gears

Because of the inclination of the teeth, the cutting of spiral gears is quite different from the method followed for spur gears, as far as the arrangement of the machine and the selection of the cutter is concerned. The spiral head must be connected to the table feed-screw by change gears that will give a spiral of the required lead, and the proper cutter to use depends upon the number of teeth in the gear, their pitch and the spiral angle. Just why the inclination of the teeth to the axis of the gear is considered when selecting a cutter will be more clearly understood by referring to the diagrammatical view of a spiral gear shown in Fig. 18. The circular pitch of the teeth is the distance  $c$  measured along the pitch circle at one end of the gear, or in a plane at right angles to the axis.

As will be seen, the circular pitch in the case of a spiral gear is not the shortest distance between the adjacent teeth, as this minimum distance  $n$  is along a line at right angles to the teeth. Hence, if a cutter is used having a thickness at the pitch line equal to one-half the circular pitch, as for spur gearing, the spaces between the teeth would be cut too wide and the teeth would be too thin. The distance  $n$  is referred to as the normal circular pitch, and the thickness of the cutter at the pitch line should equal one-half this pitch. Now, the normal pitch varies with the angle of the spiral, which is equal to angle  $\alpha$ ; consequently, the spiral angle must be considered when selecting a cutter.

If a gear has thirty teeth and a pitch diameter of 6 inches, what is sometimes referred to as the *real* diametral pitch is  $5$  ( $30 \div 6 = 5$ ) and in the case of a spur gear, a cutter corresponding to this pitch would be used; but if a 5-pitch cutter were used for a spiral gear, the tooth spaces would be cut too wide. In order to secure teeth of the proper shape when milling spiral gears, it is necessary to use a cutter of the same pitch as the normal diametral pitch.

The normal diametral pitch can be found by dividing the real diametral pitch by the cosine of the spiral angle. To illustrate, if the pitch diameter of the gear shown in Fig. 17 is 6.718 and there are 38 teeth having a spiral angle of 45 degrees, the real diametral pitch equals  $38 \div 6.718 = 5.656$ ; then the normal diametral pitch equals 5.656 divided by the cosine of 45 degrees, or  $5.656 \div 0.707 = 8$ . A cutter, then, of 8-diametral pitch is the one to use for this particular gear.

This same result could also be obtained as follows: If the circular pitch  $c$  is 0.5554 inch, the normal circular pitch  $n$  can be found by multiplying the circular pitch by the cosine of the spiral angle. For example,  $0.5554 \times 0.707 = 0.3927$ . The normal diametral pitch is next found by dividing 3.1416 by the normal circular pitch To illustrate,

$$\frac{3.1416}{0.3927} = 8, \text{ which is the diametral pitch of the cutter.}$$

Of course, in actual practice, it is not generally necessary to make such calculations, as the pitch of the gear, the lead and angle of the spiral, etc., is given on the drawing, and the work of the machinist is confined to setting up the machine and cutting the gear according to

specifications. It is much easier, however, to do work of this kind when the fundamental principles are understood.

As previously explained in Chap. II, the proper cutter to use for spur gears depends not only upon the pitch of the teeth, but also upon the number of teeth in a gear, because the teeth of a small gear do not have the same shape as those of a much larger size of the same pitch. Therefore, according to the Brown & Sharpe system for spur gears having involute teeth, eight different shapes of cutters (marked by numbers) are used for cutting all sizes of gears of any one pitch, from a 12-tooth pinion to a rack. The same style of cutter can be used

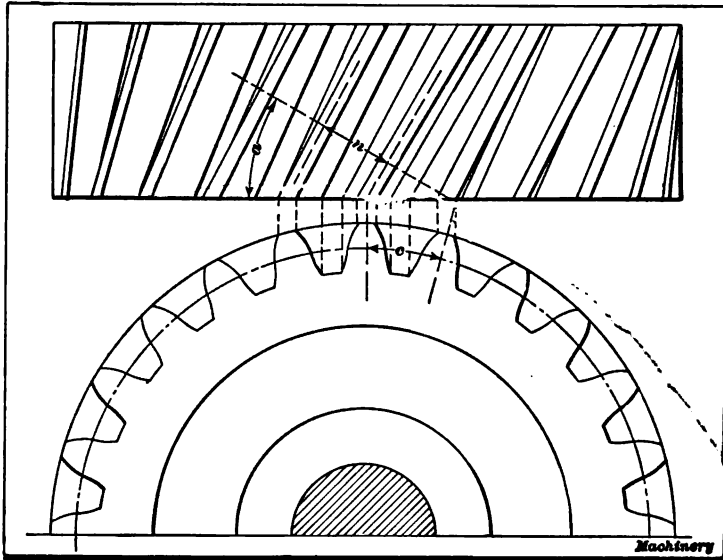

Fig. 18. The Circular Pitch of a Spiral Gear is the Distance  $c$  and the Normal Pitch, Distance  $n$

for spiral gearing, but the cutter is not selected with reference to the actual number of teeth in the gear, as with spur gearing.

By referring to the list of cutters given on page 11, Chapter II, it will be seen that a No. 3 would be used for a spur gear having 38 teeth. A spiral gear with 38 teeth, however, might require a cutter of some other number, because of the angular position of the teeth. If the actual number of teeth in a spiral gear is divided by the cube of the cosine of the tooth angle, the quotient will represent the number of teeth for which the cutter should be selected, according to the system for spur gears. If we assume that a gear is to have 38 teeth cut at an angle of 45 degrees, then the cutter to use would be determined as

follows: The cosine of 45 degrees is 0.7071 and  $38 \div 0.7071^3 = \frac{38}{0.3535} = 107$ . The list of cutters previously referred to calls for a No. 2 cutter for spur gears having any number of teeth between 55 and

134; hence, that is the cutter to use for a spiral gear having 38 teeth and a tooth angle of 45 degrees. It will be understood that this number has nothing to do with the pitch of the cutter, which is determined as previously explained; it is simply that one of the eight cutters (according to the B. & S. system) which is made for milling gears having numbers of teeth between 55 and 134.

The number obtained by the foregoing rule is much larger than the actual number of teeth in the spiral gear. This is because a line at right-angles to the teeth, along which the normal pitch is measured, has a larger radius of curvature than the pitch circle of the gear (although, strictly speaking, the term radius is incorrectly used, as this line is a helix and not a circle) and the curvature increases or diminishes for corresponding changes in the spiral angle. Therefore, the number of teeth for which the cutter is selected depends upon the angle of the spiral, as well as the actual number of teeth in the gear. As the angle becomes smaller, the difference between the normal and circular pitches also diminishes until, in the case of spur gears, the normal and circular pitches are equal.

#### Gearing Machine—Position of Table

The change gears *a*, *b*, *c* and *d*, Fig. 17, connect the spiral head and table feed-screw and rotate the gear blank as the table feeds lengthwise, in order to produce the spiral teeth. The relative sizes of these gears depend upon the lead of the spiral or the distance that any one tooth would advance if it made a complete turn around the gear. When calculating the sizes of spiral gears, the diameter and angle of the teeth is usually made to suit conditions; consequently, the lead of the spiral is sometimes an odd dimension that cannot be obtained exactly with any available combination of change gears, although some combination of the gears furnished with a universal milling machine will generally give a lead which is close enough for all practical purposes.

The gear shown in Fig. 17 has left-hand spiral teeth. Therefore it is necessary to place an idler gear *I* in the train of gears in order to reverse the rotation of the gear blank. Without this idler, the rotation would be in the opposite direction and a right-hand spiral would be milled.

Before the teeth of a spiral gear can be milled the table of the machine must be set to the spiral angle. This is done so that the cutter will produce grooves and teeth of the proper shape. As previously explained, the angle of a spiral depends upon the lead *L* (see Fig 10), and the circumference *e* of the cylindrical surface (which may be either real or imaginary) around which the spiral is formed. The smaller the circumference, the smaller the angle  $\alpha$ , assuming that the lead *L* remains the same. The angle, then, that the teeth of a spiral gear make with the axis, gradually diminishes from the tops to the bottoms of the teeth, and if it were possible to cut a groove right down to the center or axis, its angle would become zero. Hence, if the table of the machine is set to the angle at the top of a tooth, the cutter will not be in line with the bottom of the groove, and,

consequently, the teeth will not be milled to the correct shape. It is a common practice to set the table to the angle at the pitch line, which is nearly halfway between the top and bottom of the tooth, although some contend that if the angle near the bottom of the groove is taken, teeth of better shape will be obtained.

Whatever the practice may be the angle is determined by first getting the tangent and then the corresponding angle from a table of tangents. For example, if the pitch diameter of the gear is 4.46 and

the lead of the spiral is 20 inches, the tangent will equal  $\frac{4.46 \times 3.1416}{20}$

= 0.700, and 0.700 is the tangent of 35 degrees, which is the angle to which the table is set from the normal position at right angles to the spindle.

The table is adjusted by loosening the bolts which ordinarily hold it to the clamp-bed and swiveling it around until the 35-degree graduation on the circular base coincides with the stationary zero mark. Before setting the table to the spiral angle, the cutter should be located directly over the center of the gear blank. An accurate method of centering a cutter of this kind was described in connection with Fig. 8, Chapter II.

#### Milling the Spiral Teeth

The teeth of a spiral gear are proportioned from the normal pitch and not the circular pitch. The whole depth of the tooth, that is the depth of each cut, can be found by dividing the constant 2.157 by the normal diametral pitch of the gear; the latter, as will be recalled, corresponds to the pitch of the cutter. The thickness of the gear at the pitch-line equals 1.571 divided by the normal diametral pitch. After a cut is completed the cutter should be prevented from dragging over the teeth when being returned for another cut. This can be done by lowering the blank slightly or by stopping the machine and turning the cutter to such a position that the teeth will not touch the work. If the gear has teeth coarser than 10 or 12 diametral pitch, it is well to cut twice around; that is, take a roughing and a finishing cut.

When pressing a spiral gear blank on the arbor, it should be remembered that spiral gears are more likely to slip when being cut than spur gears. This is because the tooth grooves are at an angle and the pressure of the cut tends to rotate the blank on the arbor.

## CHAPTER IV

### THE VERTICAL MILLING MACHINE

When an end mill is driven directly by inserting it in the spindle of a milling machine of the horizontal type it is often difficult to do satisfactory work, especially if much hand manipulation is required, because the mill operates on the rear side where it cannot readily be seen when one is in the required position for controlling the machine. Moreover, it is frequently necessary to clamp the work against an angle-plate to locate it in a vertical position or at right-angles to the end mill, when the latter is driven by a horizontal spindle. In order to overcome these objectionable features special vertical milling attachments are used to convert a horizontal machine temporarily into a vertical type. These vertical attachments are very useful, especially when the shop equipment is comparatively small and a horizontal machine must be employed for milling a great many different parts, but where there is a great deal of work that requires end milling, it is better to use a machine having a vertical spindle.

A vertical milling machine is shown in Fig. 19. The part to be milled is attached to table *T* and the cutter is driven by the vertical spindle *S*, so that it is always in plain view. This is particularly desirable when milling an irregular outline, or any part that requires close attention.

The table of this machine has longitudinal, crosswise, and vertical movements, all of which can be effected either by hand or by the automatic power feeds. The spindle and the slide which supports the lower end can also be fed vertically, within certain limits, by hand or power. It should be mentioned that milling machines of this type do not always have vertical movements for both the spindle and table. In some designs the table, instead of being carried by a sliding knee *K*, is mounted on a fixed part of the base which extends forward beneath it; whereas other machines have a table that can be moved vertically, but a spindle that remains fixed, as far as vertical movement is concerned.

The particular machine shown in Fig. 19 is driven by a belt pulley *P*, which transmits power through gears and shafts to spindle *S*. This belt pulley is connected or disconnected with the driving shaft by vertical lever *M*, which serves to start and stop the machine. The speed of the spindle is varied by levers *A*, *B*, *C*, and *D*. Levers *A* and *B* operate a tumbler-gear through which four speeds are obtained. This number is doubled by lever *C*, and lever *D* doubles it again, thus giving a total of sixteen speeds. The direction of rotation is reversed by lever *H*.

The power feeds for the table are varied by the levers seen attached

to the feed-box *F*. The feed motion is transmitted to a reversing box on the side of the knee, by a telescoping shaft, the same as with a horizontal machine. Lever *R* may be used to start, stop or reverse the automatic table feeds; lever *V* controls the vertical movement of the knee and table; and lever *N* the cross-movement. The table is reversed by lever *L* at the front, the reversing lever *R* not being used for this

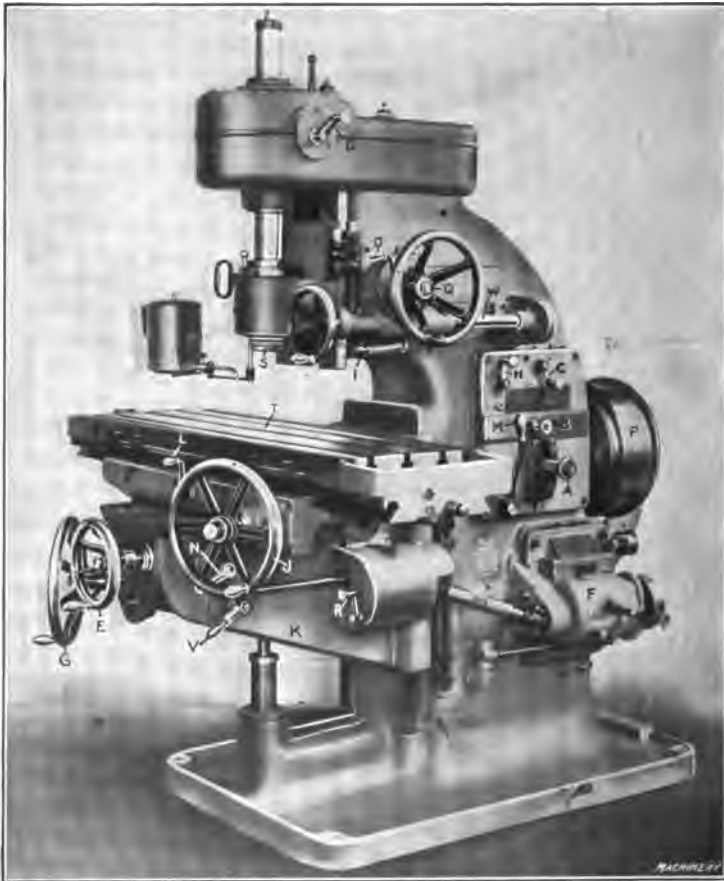

Fig. 19. Brown & Sharpe Vertical-spindle Milling Machine

purpose. The handwheel *G* is for raising and lowering the table, and the smaller wheel *E* is for the transverse adjustment. By means of handwheel *J* the table can be given a fast or slow movement, or the wheel can be disconnected entirely, a clutch in the center of the hub being used to make these changes. The handwheels *E* and *G* can also be disengaged from their shafts by knobs in the center of each wheel. This is done to prevent the table from being shifted after an adjustment is made, in case the workman should accidentally turn one of the wheels.



The vertical feed for the spindle head is also varied by the mechanism at *F*, the required motion being transmitted to the top of the machine by a chain and sprockets which drive worm-shaft *W*. This worm-shaft is connected with the upper sprocket through a clutch controlled by lever *I*. This same clutch is also operated by adjustable stops clamped into T-slots in the side of the spindle-head, for automatically disengaging the vertical feed at any predetermined point. Shaft *W* transmits the feeding movement to the spindle, through worm gearing, and a pinion shaft *Q*, and lever *O* engages or disengages the worm-wheel with this pinion shaft. When the worm-wheel is disengaged, the large handwheel at the side of the column may be used to raise or lower the spindle rapidly, and, at other times, the small hand-wheel at the front gives a slow feeding movement.

#### Circular Milling Attachment

The vertical milling machine is often used for milling circular surfaces or slots. In order to do this it is necessary to impart a rotary movement to the piece being milled. This is done by means of a circular milling attachment which is bolted to the main table of the machine, as shown in Fig. 21. The table of the attachment can be revolved by handwheel *A* or automatically. The power feed is derived from the splined shaft which drives the longitudinal feed-screw of the table, this shaft being connected by a chain and sprockets to shaft *B* which transmits the movement to the attachment. When the attachment is in use the table feed-screw is disconnected from the splined shaft, so that the feeding movement is transmitted to the circular table only. For adjusting the longitudinal table, when using the circular attachment, a crank is applied to the squared end of the screw at the left end of the table. The circular attachment has automatic stops for disengaging the feed at any point, which are held in a circular T-slot cut in the periphery of the table. The circumference of the table is also graduated in degrees, so that angular adjustments can be made when necessary.

#### Vertical Milling Operations

The vertical milling machine illustrated in Fig. 19 is shown at work in Fig. 20. The casting *C*, which is being milled, is the saddle of a milling machine, and the operation is that of finishing the dovetail ways for the table. The ways on the under side have already been milled and this finished part is placed against a plate or fixture *F*, having a slide similar to the knee upon which the saddle will be mounted when assembled.

The cutter used for this job has radial end teeth for milling the flat or bottom surfaces, and angular teeth for finishing the dovetail. The cutter revolves in a fixed position, and the slide is milled by feeding the table endwise after it is adjusted to the proper vertical and crosswise positions. The fixture is made in two parts, and the top section can be swiveled slightly so that the dovetail can be milled tapering on one side for the gib which is afterward inserted. The top part of the fixture is located in the proper position when milling

either the straight or taper side, by a pin which passes through the upper and lower plates.

#### Milling a Circular T-slot

The operation illustrated in Fig. 21, as previously intimated, requires the use of a circular attachment, as it is necessary to mill a circular T-slot. The casting in which this slot is being cut, is the wheel-stand slide of a cylindrical grinder and the slot receives the



Fig. 20. Example of Milling on Vertical Milling Machine

heads of clamping bolts. As the T-slot must be concentric with a hole previously bored in the casting, it is necessary to locate this hole in the center of the circular table. This is done by placing an arbor in the central hole of the table, having a bushing which just fits the hole in the casting. The latter is held to the circular table by a clamp and the bolts shown.

The T-slot is formed by two operations: A plain, rectangular slot is cut first by using an ordinary end-mill, and then the enlarged T-section at the bottom is milled by a special T-slot cutter. This particular view was taken after the T-slot cutter had completed about one-quarter of the groove. The cutter rotates in one position and the circular

groove is milled as the casting is slowly fed around by the circular attachment. The shape of the finished slot is clearly shown to the left, and the plain rectangular slot cut by the first operation is shown to the right.

#### Examples of End and Edge Milling

Fig. 22 shows how a vertical machine is used for milling the bearing brasses of an engine connecting-rod. These brasses are cast with



Fig. 21. Milling a Circular T-slot on a Vertical Machine

flanged sides which must be finished to fit the strap which holds the brasses in position on the rod. An end-mill is used for this work. The end or radial teeth finish the bottom of the groove, while the cylindrical part of the mill finishes the groove to the required width. The brasses are clamped to a special box-shaped angle-plate, and four sets are milled at one passage of the tool. For finishing the opposite sides, the milled surfaces are "bedded" on a cylindrical rod to align them with the table. In this way both sides are finished parallel.

Work of this kind is often done in the shaper, but these small brasses can be finished more rapidly by milling, as the bottom of the

grooves and the sides of the flanges are milled simultaneously, whereas, with the shaper it would be necessary (with a single-pointed tool) to cut down each side and plane the horizontal surface at the bottom of the groove, separately. Furthermore, it is easier to mill these brasses to a uniform size than to plane them in a shaper. When milling, the width between the flanges is governed by the diameter of the cutter, but if a shaper were used, this width would depend on the adjustment of the tool, which might not always be set in exactly the



Fig. 22. Milling Connecting-rod Bearing Brasses on Becker Vertical Machine

same position. The vertical milling machine used for this operation, is not the same as the one previously illustrated, although its construction is very similar and it is used for the same class of work.

The vertical milling machine is often used for finishing the edges of straight or circular parts, and irregular shapes can also be worked out by using the longitudinal and cross feeds alternately, as may be required. Of course, if an irregular outline is to be followed, the machine is fed by hand. At A, Fig. 23, is shown an odd-shaped steel forging, the rough end and sides of which are finished by milling, as indicated at B. The straight sides and part of the circular hub are

first milled as shown in this illustration. As the hole through the hub has already been bored, this is used for locating the forging in a central position, the bored hub being placed over a close-fitting cylindrical piece that is clamped to the table as shown. The work is held by a bolt and heavy washer at the top, and it is kept from turning by a small angle-plate which is set against the flanged end.

As the illustration shows, the edge is finished by a spirally-fluted end-

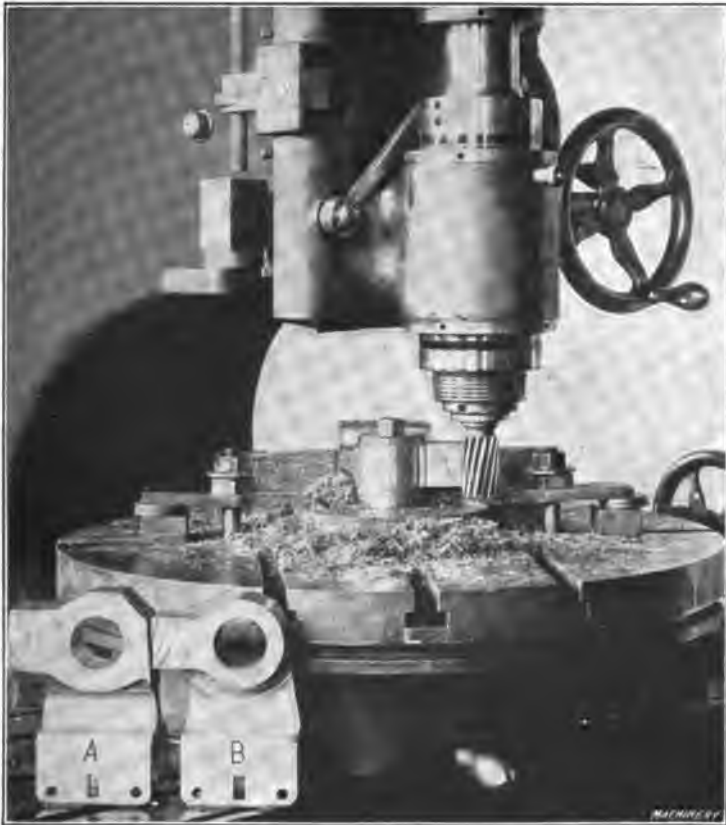

Fig. 23. Milling the Edge of a Steel Forging

mill. The table of the machine is fed longitudinally for milling the straight part, and then the circular attachment is used for finishing the circular hub, around as far as the projecting flanged end will permit. The circular end of the hub is then completed (as shown in Fig. 24) by using a different type of cutter which rounds that part of the hub next to the projecting end and gives a finished appearance to the work. This cutter, which is called a "rose mill," has a spherical end that forms a fillet as it feeds around.

This particular forging may require a little handwork for finishing

one or two rough, uneven spots left by milling, but this is very slight at the most. Without a milling machine, however, it would be necessary to trim up this part by hand, and to make a neat job of it would require considerable time. In fact, before the milling machine came into use, vise or handwork was done on a much more extensive scale than at the present time, and, incidentally, the amount of handwork in connection with the fitting and erecting of machinery, is gradually



Fig. 24. Finishing a Circular Fillet with a Rose Milling Cutter

diminishing, owing to the high degree of accuracy with which parts can be finished, not only by milling but by modern machines and methods generally.

When milling edges in the vertical machine, the depth of the cut is sometimes limited by the spring of the cutter arbor, although when quite wide edges have to be milled, the arbor is sometimes supported at the lower end by a bracket which is attached to the column of the machine. This prevents the cutter from springing away from the work, and enables fairly heavy cuts to be taken.

## Surface Milling in the Vertical Machine

While the vertical milling machine is especially adapted for milling straight or curved edges or surfaces of irregular shape, it is also very efficient for finishing plain, flat surfaces on certain classes of work. Frequently the top of a casting or forging and its sides or edges, can be milled at one setting, which not only saves time but insures accuracy. When a flat, horizontal surface is milled in a vertical machine,

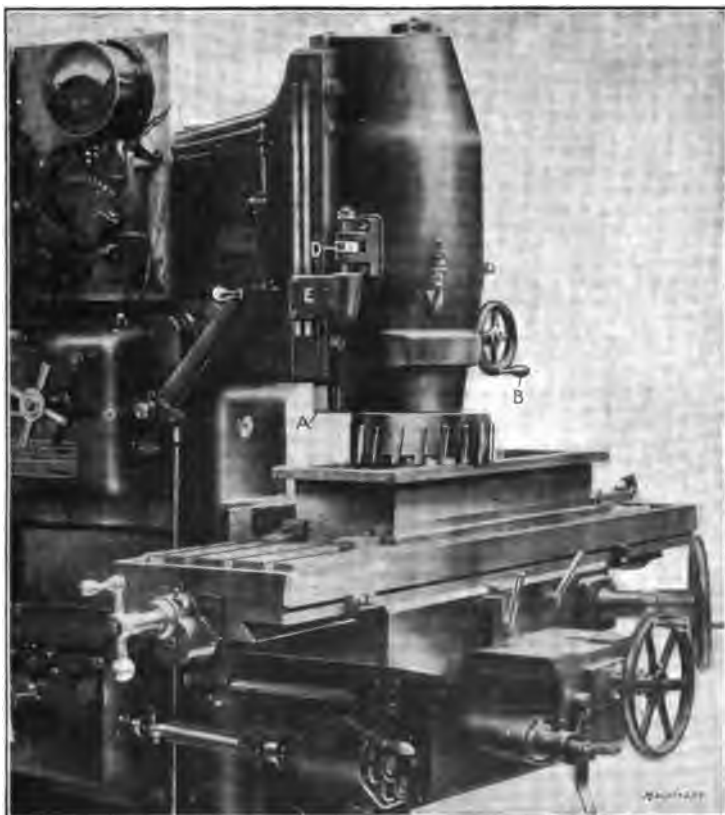

Fig. 25. Finishing Top Surface of a Casting on a Cincinnati Vertical Machine

a face cutter is used, as shown in Fig. 25. This cutter, which is over 12 inches in diameter, is screwed to the end of the spindle and the flange around the casting *C* is milled by the ends of the inserted teeth or blades. This cutter is large enough to mill both sides of the casting in one cut. The over-all dimensions of this part are 12 by 36 inches, and the width of the flanges on each side is 2 inches.

The machine shown in this illustration is a powerful, rigid design especially adapted for work of this kind. It is similar in many respects to the plain horizontal machine described in Chapter I, Part I,

of this treatise, excepting, of course, the changes necessary on account of the vertical location of the spindle. The part to be milled is bolted directly to the table, and, before milling the first casting, the knee is elevated, so that the spindle slide *A* will not need to extend much below its bearing when the cutter is at work. The spindle and cutter are then lowered for the right depth of cut by using the fine hand-feed which is operated by the small wheel *B* at the right of the spindle. After rough milling the surface by traversing the table longitudinally, the feed is reversed and a finishing cut 0.010 of an inch deep is taken, as the table feeds in the opposite direction.



Fig. 26. Machine equipped with Two Work-holding Fixtures so that One Casting can be chucked while the Other is being Milled

The micrometer stop *D* which engages an arm *E* bolted to the side of the column, makes it possible to set the cutter to the same vertical position, when milling a number of castings of the same height. This same casting can also be milled by using a smaller cutter which covers a flange on one side only, instead of the entire casting. When the smaller cutter is employed, it is made to follow the rectangular flange by using the longitudinal and cross feeds, alternately.

The example of vertical face milling shown in Fig. 26 illustrates a modern method of chucking castings and operating the machine, when large numbers of duplicate parts have to be milled. There are two independent work-holding fixtures mounted on the table, and the cutter moves from one casting to another. First a roughing cut is taken about  $\frac{3}{16}$  inch deep, with the table feeding  $7\frac{1}{4}$  inches per minute. When the working side of the cutter reaches the end of the casting, the feed is reversed and increased to 20 inches per minute for



the return or finishing cut. Meanwhile, another casting is placed in the other fixture, and when the cutter reaches it, the feed is reduced to  $7\frac{1}{4}$  inches. While this roughing cut is being taken, a new piece is chucked in the other fixture, and so on, one casting being chucked while the other is being milled, so that the milling operation is practically continuous. Of course, this method of handling the work, cannot be employed unless it is possible to clamp the part in the proper position in a comparatively short time. The fixtures shown in this illustration are made like milling machine vises and have special jaws

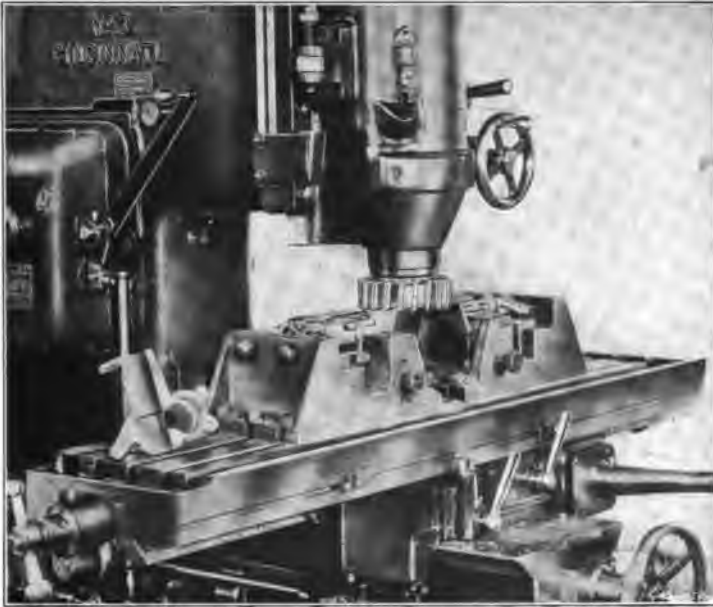

Fig. 27. Another Milling Operation Employing Two Fixtures

with angular faces which hold a casting firmly against the base of the vise.

Fig. 27 shows a continuous milling operation similar to the one just referred to, as far as the method of chucking the work is concerned. There are two independent fixtures, as before, and the castings are inserted in each fixture alternately; that is, one is being chucked while the other is being milled. The machine is fitted with an automatic reverse, and the table travels back and forth without stopping. Two cuts are taken across each piece; first a roughing cut and then a finishing cut on the return movement of the table. One of the finished castings is shown on the left end of the table. The material is malleable iron and the milled surface has an over-all dimension of 6 by 7 inches. From  $1/16$  to  $3/32$  inch metal is removed, and the table feeds  $12\frac{1}{2}$  inches per minute.

**Continuous Circular Milling**

The continuous method of face milling is also done in connection with a circular attachment. The parts to be milled are held in a fixture near the edge of the table, and, as the latter revolves, one casting after another is fed beneath the revolving cutter. An example of continuous circular milling is shown in Fig. 28. The operation is that of milling sad-irons. These are held in a fixture having a capacity for fourteen castings. The table makes one revolution in from three to four minutes when doing this particular work. As the finished cast-

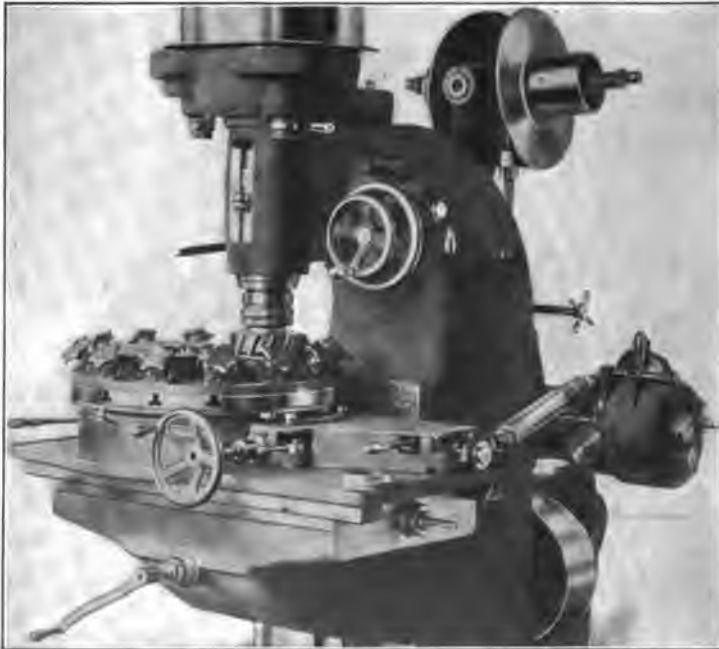

**Fig. 28. Becker Vertical-spindle Machine for Continuous Circular Milling**

ings come around to the front they are removed and replaced by rough ones, without stopping the machine so that the milling operation is continuous. From two thousand to three thousand castings can be milled per day by this method, the number depending on the kind of material. The fixture has star-shaped clamping nuts which make it possible to quickly release a finished casting or clamp a rough one in position. This machine is not a regular vertical milling machine of the standard type, but is especially designed for continuous circular milling. The table is without cross adjustment but can be fed longitudinally for straight surface milling. Continuous circular milling is also done on standard vertical machines by using the circular milling attachment, as previously mentioned.

## CHAPTER V

### LINCOLN AND PLANER-TYPE MILLING MACHINES

The milling machine shown in Fig. 29 is intended especially for manufacturing; that is, it is not adapted to a great variety of milling operations but is designed for machining large numbers of duplicate parts. The construction is very rigid but comparatively simple, and,

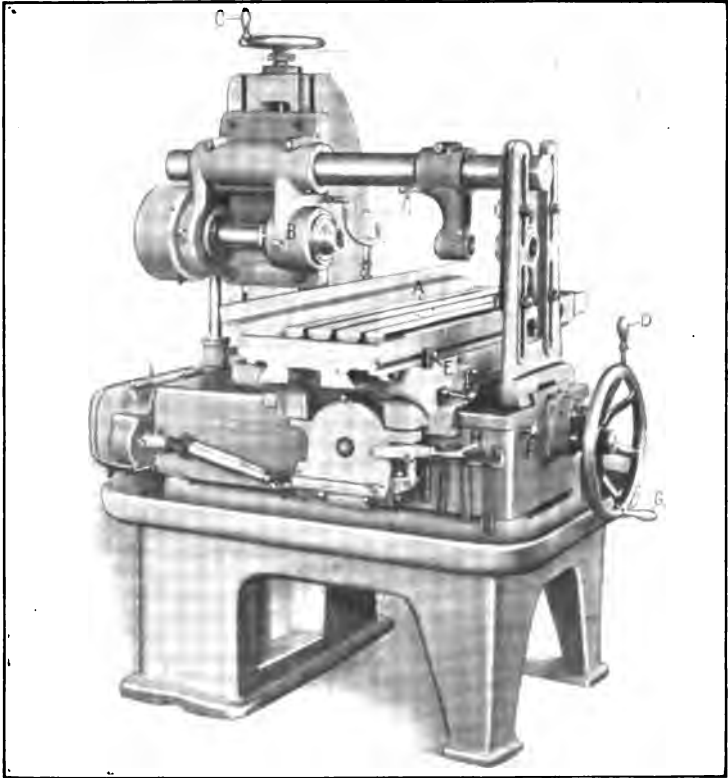

Fig. 29. Brown & Sharpe Plain Milling Machine of the Lincoln Type

therefore, this style of machine is preferable to the more complicated designs for work within its range. Milling machines having the same general construction as the one illustrated, are often referred to as the Lincoln type. As will be noted, the work-table *A*, instead of being carried by an adjustable knee, is mounted on the solid bed of the machine and the outer arbor-support is also bolted directly to the bed. This connection gives a very rigid support both for the work and cut-

ter. The work is usually held in a fixture or vise attached to the table, and the milling is done as the table feeds longitudinally.

The table is not adjustable vertically, but the spindle-head *B* with the spindle, can be raised or lowered as may be required. This vertical adjustment of the spindle-head is effected by turning handwheel *C* which has a graduated collar reading to thousandths of an inch. After the spindle has been adjusted vertically, the head is clamped to the upright by the four bolts shown. The spindle is driven from a pulley at the rear which transmits the motion through shafting and gearing.

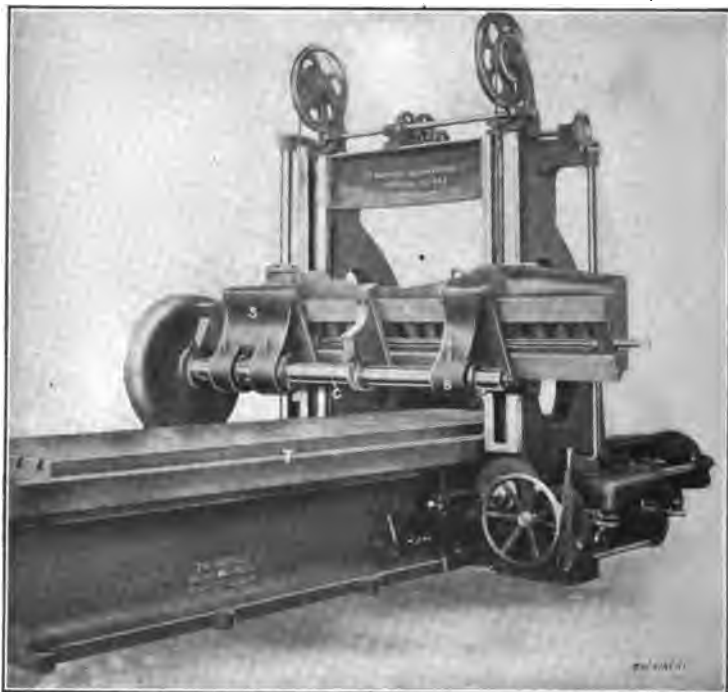

Fig. 80. Ingersoll Horizontal or Planer-type Milling Machine

A friction clutch is located in this driving pulley and provides means for starting and stopping the machine. This clutch is operated by the hand-lever *D*.

The table has a longitudinal power feed in either direction, which can be varied to suit requirements. This power feed can be automatically disengaged at any point by setting the adjustable stops *E* in the proper position. The direction of the feed can also be reversed by operating reverse-rod *F*. The large handwheel *G* can be used for adjusting the table lengthwise or crosswise. Normally this handwheel is in position for traversing the table lengthwise. When a transverse movement is required in order to locate the work with reference to the cutter, the handwheel is pushed inward, which engages it with the cross-feed

screw. Before using the hand traverse, the worm-gearing of the power feed mechanism should be disengaged by operating lever *H*. The variations in both spindle speeds and table feeds are obtained, on this particular machine, by means of change gears. As machines of this kind are frequently used for a long time on one class of work, it is not necessary to make speed or feed changes very often.

This machine has a maximum longitudinal feed for the table of 34 inches; a transverse adjustment of 6 inches, and a vertical adjustment for the spindle of 12 inches. The variety of milling that can be done on a machine of this type is small as compared with the column-and-knee machines, but it is intended for milling operations that are of the

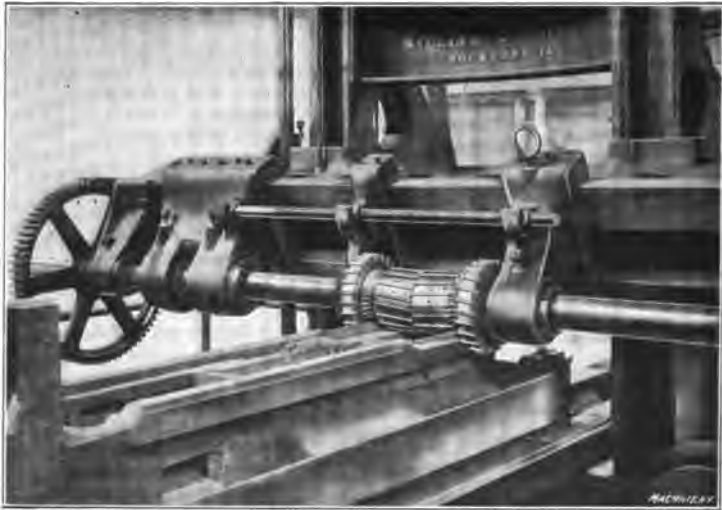

Fig. 31. Milling the Ways of a Turret Lathe Bed on a Horizontal Machine

same general character, so that a great capacity or "range" is not needed. The Lincoln type is used very effectively in connection with the manufacture of firearms, sewing machines, electrical instruments and many other kinds of machinery.

#### Horizontal Milling Machines of the Planer Type

The machine illustrated in Fig. 30 is designed for heavy milling operations. This style of milling machine is sometimes referred to as a planer or slab type; as the illustration shows, it is built somewhat like a planer. The work-table *T* is mounted on a long bed, and the cutter arbor *C* is carried by a cross-rail *A* which, in turn, is attached to vertical housings. The cutter arbor is driven by gearing at the left end, and it can be adjusted longitudinally by traversing the main saddle *S* along the cross-rail. The outer end of the arbor is supported by a bearing *B*, and there is also an intermediate support. The work-table has an automatic feeding movement along the bed, and it can be traversed rapidly by power, in either direction, when the position

needs to be changed considerably. The power feed can be automatically disengaged at the end of the cut by a tappet which is shifted along the side of the bed to the required position. The cross-rail can be raised or lowered to locate the cutter at the required height, and

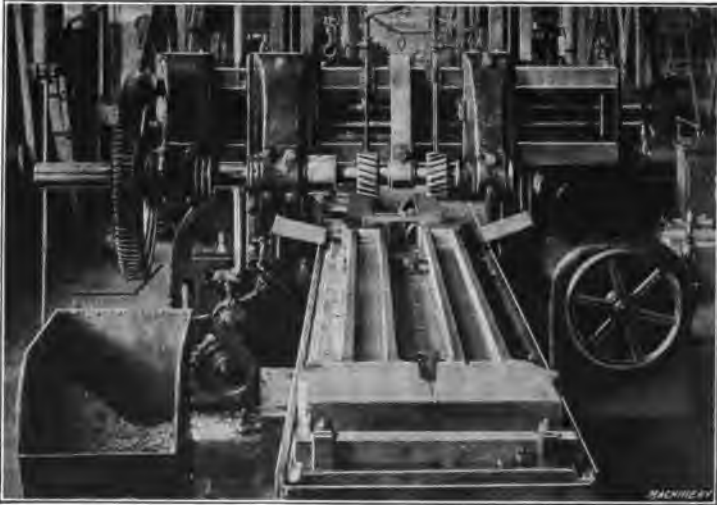

Fig. 32. Channeling the Sides of Locomotive Main-rod on Horizontal Machine

it is counterbalanced by weights attached to wire ropes that pass over the pulleys at the top of the housings.

Fig. 31 shows how a horizontal machine of this kind is used for milling a large casting. The particular part illustrated is the bed of a turret lathe, and the operation is that of milling the V-shaped ways,



Fig. 33. Cutters used for Channeling Main-rod

the flat surfaces inside these ways and the outer sides or edges. The arrangement of the gang of eight cutters is clearly shown by the illustration. The bed has been moved away from the cutters somewhat, in order to show the shape of the milled surfaces. The V-shaped ways are milled by angular cutters and the flat inner surfaces by cylindrical cutters, while the edges are trued by large side mills. This gang of

cutters rotates to the right, as viewed from the operating side of the machine, and the table feeds toward the rear or against the cutter rotation.

The great advantage of machining a casting in this way is that all the surfaces are milled to shape at one passage of the work. This same casting could be machined in a planer, which is true of practically all work done on large horizontal milling machines, but whether a planer or a milling machine should be used is a question that is often difficult to decide. The number of parts to be milled and the general character of the work, must be considered. To illustrate, it

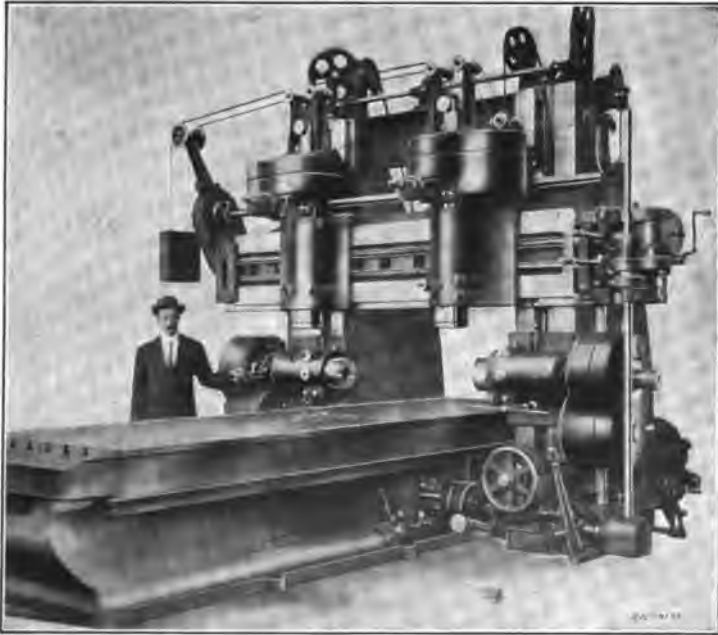

Fig. 34. Ingersoll Four-head Milling Machine

might be possible to finish a casting by milling much more rapidly than by planing. It does not necessarily follow, however, that milling will be more economical than planing. In the first place, milling cutters are much more expensive than the single-pointed planer tools which can be forged to shape by a blacksmith or toolsmith, and more time is also required to set up a milling machine than a planer, especially when a gang of cutters must be arranged for milling several surfaces simultaneously. Hence, if only a few parts are required and the necessary milling cutters are not in stock, the cost of the cutters, and the time for arranging the machine, might much more than offset the time gained by the milling process. On the other hand, when a large number of duplicate parts are required, milling is often much more economical than planing. It must not be inferred from this that

the planer should always be used for small quantities of work, and the milling machine when there is a large number of parts, although the quantity of work to be done, frequently decides the question. Sometimes planing is preferred to milling, because the surface left by a planing tool is more desirable, in certain cases, than a milled surface.

When castings or forgings are quite long and narrow, two parts are sometimes clamped side by side on the bed and milled at the same time by separate cutters. Fig. 32 illustrates a job of this kind. The two steel forgings on the machine are the main rods of a locomotive, the sides of which have been channeled or grooved to form an I-beam section. This lightens the rod considerably but leaves it strong enough to resist the various stresses to which it is subjected. This view was taken after the channels on one side were milled. These channels are milled from the solid, and the cutters used for this work are shown on an enlarged scale in Fig. 33. They have inserted spiral teeth which incline in opposite directions to neutralize the endwise thrust. They are  $8\frac{1}{4}$  inches in diameter and their width is  $4\frac{1}{2}$  inches, which corresponds to the width of the channel. When milling, these cutters revolve 36 revolutions per minute, giving a peripheral speed of 82 feet per minute. The channel or groove is  $1\frac{1}{4}$  inches deep, and it is milled in two cuts, each having a depth of  $\frac{7}{8}$  inch. A constant stream of lubricant pours on each cutter through the hose and vertical pipes seen attached to the cross-rail. When setting up work for an operation of this kind, it must be held securely against endwise movement, because the pressure of such heavy milling cuts is very great. In this case, the rods rest against a heavy steel block which is fastened across the end of the table to resist the endwise thrust of the cut.

#### Multiple-head Milling Machine

Horizontal machines are built in many different designs which are modified to suit different classes of work. Fig. 34 shows a machine which, instead of having a single cutter-arbor, is equipped with four heads. Two of these heads are carried by the cross-rail and the other two are attached to the right and left housings. The cross-rail heads have vertical spindles and the side-heads, horizontal spindles, so that the sides and top surfaces of castings can be milled simultaneously. The side-heads can be adjusted vertically on the housings, and the vertical heads laterally along the cross-rail. This particular machine will drive face mills up to 20 inches in diameter.

Machines of the same general design are also built with three heads, one being on the cross-rail and two on the housings, and there are various other modifications. With the multiple-spindle machines, the number of spindles used at one time depends, of course, on the nature of the work. For some jobs it is necessary to use the horizontal spindles, whereas other parts are milled by using the horizontal and vertical spindles in combination. This type of machine is very efficient for certain kinds of milling.



- No. 45. Drop Forging.—Lay-out of Plant; Methods of Drop Forging; Dies.
- No. 46. Hardening and Tempering.—Hardening Plants; Treating High-Speed Steel; Hardening Gages.
- No. 47. Electric Overhead Cranes.—Design and Calculation.
- No. 48. Files and Filing.—Types of Files; Using and Making Files.
- No. 49. Girders for Electric Overhead Cranes.
- No. 50. Principles and Practice of Assembling Machine Tools, Part I.
- No. 51. Principles and Practice of Assembling Machine Tools, Part II.
- No. 52. Advanced Shop Arithmetic for the Machinist.
- No. 53. Use of Logarithms and Logarithmic Tables.
- No. 54. Solution of Triangles, Part I.—Methods, Rules and Examples.
- No. 55. Solution of Triangles, Part II.—Tables of Natural Functions.
- No. 56. Ball Bearings.—Principles of Design and Construction.
- No. 57. Metal Spinning.—Machines, Tools and Methods Used.
- No. 58. Helical and Elliptic Springs.—Calculation and Design.
- No. 59. Machines, Tools and Methods of Automobile Manufacture.
- No. 60. Construction and Manufacture of Automobiles.
- No. 61. Blacksmith Shop Practice.—Model Blacksmith Shop; Welding; Forging of Hooks and Chains; Miscellaneous.
- No. 62. Hardness and Durability Testing of Metals.
- No. 63. Heat Treatment of Steel.—Hardening, Tempering, Case-Hardening.
- No. 64. Gage Making and Lapping.
- No. 65. Formulas and Constants for Gas Engine Design.
- No. 66. Heating and Ventilation of Shops and Offices.
- No. 67. Boilers.
- No. 68. Boiler Furnaces and Chimneys.
- No. 69. Feed Water Appliances.
- No. 70. Steam Engines.
- No. 71. Steam Turbines.
- No. 72. Pumps, Condensers, Steam and Water Piping.
- No. 73. Principles and Applications of Electricity.—Static Electricity; Electrical Measurements; Batteries.
- No. 74. Principles and Applications of Electricity.—Magnetism; Electro-Magnetism; Electro-Plating.
- No. 75. Principles and Applications of Electricity.—Dynamos; Motors; Electric Railways.
- No. 76. Principles and Applications of Electricity.—Electric Lighting.
- No. 77. Principles and Applications of Electricity.—Telegraph and Telephone.
- No. 78. Principles and Applications of Electricity.—Transmission of Power.
- No. 79. Locomotive Building.—Main and Side Rods.
- No. 80. Locomotive Building.—Wheels; Axles; Driving Boxes.
- No. 81. Locomotive Building.—Cylinders and Frames.
- No. 82. Locomotive Building.—Valve Motion.
- No. 83. Locomotive Building.—Boiler Shop Practice.
- No. 84. Locomotive Building.—Erecting.
- No. 85. Mechanical Drawing.—Instruments; Materials; Geometrical Problems.
- No. 86. Mechanical Drawing.—Projection.
- No. 87. Mechanical Drawing.—Machine Details.
- No. 88. Mechanical Drawing.—Machine Details.
- No. 89. The Theory of Shrinkage and Forced Fits.
- No. 90. Railway Repair Shop Practice.
- No. 91. Operation of Machine Tools.—The Lathe, Part I.
- No. 92. Operation of Machine Tools.—The Lathe, Part II.
- No. 93. Operation of Machine Tools.—Planer, Shaper, Slotter.
- No. 94. Operation of Machine Tools.—Drilling Machines.
- No. 95. Operation of Machine Tools.—Boring Machines.
- No. 96. Operation of Machine Tools.—Milling Machines, Part I.
- No. 97. Operation of Machine Tools.—Milling Machines, Part II.
- No. 98. Operation of Machine Tools.—Grinding Machines.
- No. 99. Automatic Screw Machine Practice.—Operation of the Brown & Sharpe Automatic Screw Machine.
- No. 100. Automatic Screw Machine Practice.—Designing and Cutting Cams for the Automatic Screw Machine.
- No. 101. Automatic Screw Machine Practice.—Circular Forming and Cut-off Tools.
- No. 102. Automatic Screw Machine Practice.—External Cutting Tools.
- No. 103. Automatic Screw Machine Practice.—Internal Cutting Tools.
- No. 104. Automatic Screw Machine Practice.—Threading Operations.
- No. 105. Automatic Screw Machine Practice.—Knurling Operations.
- No. 106. Automatic Screw Machine Practice.—Cross Drilling, Burring and Slotting Operations.
- No. 107. Drop Forging Dies and Die-Sinking.—A Complete Treatise on Die-Sinking Methods.
- No. 108. Die Casting Machines.
- No. 109. Die Casting.—Methods and Machines Used; the Making of Dies for Die Casting.
- No. 110. The Extrusion of Metals.—Machines and Methods Used in a Little-known Field of Metal Working.
- No. 111. Lathe Bed Design.
- No. 112. Machine Stops, Trips and Locking Devices.—Also includes Reversing Mechanisms and Clamping Devices.

ADDITIONAL TITLES WILL BE ANNOUNCED IN MACHINERY FROM TIME TO TIME

# MACHINERY'S DATA SHEET SERIES

MACHINERY'S Data Sheet Books include the well-known series of Data Sheets originated by MACHINERY, and issued monthly as supplements to the publication; of these Data Sheets over 500 have been published, and 6,000,000 copies sold. Revised and greatly amplified, they are now presented in book form, kindred subjects being grouped together. The price of each book is 25 cents (one shilling) delivered anywhere in the world.

## CONTENTS OF DATA SHEET BOOKS

**No. 1. Screw Threads.**—United States, Whitworth, Sharp V. and British Association Threads; Briggs Pipe Thread; Oil Well Casing Gages; Fire Hose Connections; Acme, Worm and Metric Threads; Machine, Wood, Lag Screw, and Carriage Bolt Threads, etc.

**No. 2. Screws, Bolts and Nuts.**—Fillister-head, Headless, Collar-head and Hexagon-head Screws; Standard and Special Nuts; T-nuts, T-bolts and Washers; Thumb Screws and Nuts; Machine Screw Heads; Wood Screws; Tap Drills.

**No. 3. Taps and Dies.**—Hand, Machine, Tapper and Machine Screw Taps; Taper Die Taps; Sellers Hobs; Screw Machine Taps; Straight and Taper Boller Taps; Stay-bolt, Washout, and Patch-bolt Taps; Pipe Taps and Hobs; Threading Dies.

**No. 4. Reamers, Sockets, Drills and Milling Cutters.**—Hand Reamers; Shell Reamers and Arbors; Pipe Reamers; Taper Pins and Reamers; Brown & Sharpe, Morse and Jarno Taper Sockets and Reamers; Drills; Wire Gages; Milling Cutters; Setting Angles for Milling Teeth in End Mills and Angular Cutters, etc.

**No. 5. Spur Gearing.**—Diametral and Circular Pitch; Dimensions of Spur Gears; Tables of Pitch Diameters; Odontograph Tables; Rolling Mill Gearing; Strength of Spur Gears; Horsepower Transmitted by Cast-iron and Rawhide Pinions; Design of Spur Gears; Epicyclic Gearing.

**No. 6. Bevel, Spiral and Worm Gearing.**—Rules and Formulas for Bevel Gears; Strength of Bevel Gears; Design of Bevel Gears; Rules and Formulas for Spiral Gears; Diagram for Cutters for Spiral Gears; Rules and Formulas for Worm Gearing, etc.

**No. 7. Shafting, Keys and Keyways.**—Horsepower of Shafting; Strength of Shafting; Forcing, Driving, Shrinking and Running Fits; Woodruff Keys; Standard Keys; Gib Keys; Milling Keyways; Duplex Keys.

**No. 8. Bearings, Couplings, Clutches, Crane Chain and Hooks.**—Pillow Blocks; Babbitted Bearings; Ball and Roller Bearings; Clamp Couplings; Flange Couplings; Tooth Clutches; Crab Couplings; Cone Clutches; Universal Joints; Crane Chain; Crane Hooks; Drum Scores.

**No. 9. Springs, Slides and Machine Details.**—Formulas and Tables for Spring Calculations; Machine Slides; Machine Handles and Levers; Collars; Hand Wheels; Pins and Cotter; Turn-buckles.

**No. 10. Motor Drive, Speeds and Feeds, Change Gearing, and Boring Bars.**—Power required for Machine Tools; Cutting Speeds and Feeds for Carbon and High-speed Steel; Screw Machine Speeds and Feeds; Heat Treatment of High-speed Steel Tools; Taper Turning; Change Gearing for the Lathe; Boring Bars and Tools.

**No. 11. Milling Machine Indexing, Clamping Devices and Planer Jacks.**—Tables for Milling Machine Indexing; Change Gears for Milling Spirals; Angles for setting Indexing Head when Milling Clutches; Jig Clamping Devices.

**No. 12. Pipe and Pipe Fittings.**—Pipe Threads and Gages; Cast-iron Fittings; Bronze Fittings; Pipe Flanges; Pipe Bends; Pipe Clamps and Hangers.

**No. 13. Boilers and Chimneys.**—Flue Spacing and Bracing for Boilers; Strength of Boiler Joints; Riveting; Boiler Setting; Chimneys.

**No. 14. Locomotive and Railway Data.**—Locomotive Hollers; Bearing Pressures for Locomotive Journals; Locomotive Classifications; Rail Sections; Frogs, Switches and Cross-overs; Tires; Tractive Force; Inertia of Trains; Brake Levers.

**No. 15. Steam and Gas Engines.**—Saturated Steam; Steam Pipe Sizes; Steam Engine Design; Volume of Cylinders; Stuffing Boxes; Setting Corliss Engine Valve Gears; Condenser and Air Pump Data; Horsepower of Gasoline Engines; Automobile Engine Crankshafts, etc.

**No. 16. Mathematical Tables.**—Squares of Mixed Numbers; Functions of Fractions; Circumference and Diameters of Circles; Tables for Spacing of Circles; Solution of Triangles; Formulas for Solving Regular Polygons; Geometrical Progression, etc.

**No. 17. Mechanics and Strength of Materials.**—Work; Energy; Centrifugal Force; Center of Gravity; Motion; Friction; Pendulum; Falling Bodies; Strength of Materials; Strength of Flat Plates; Strength of Thick Cylinders, etc.

**No. 18. Beam Formulas and Structural Design.**—Beam Formulas; Sectional Moduli of Structural Shapes; Beam Charts; Net Areas of Structural Angles; Rivet Spacing; Splices for Channels and I-beams; Stresses in Roof Trusses, etc.

**No. 19.—Belt, Rope and Chain Drives.**—Dimensions of Pulleys; Weights of Pulleys; Horsepower of Belting; Belt Velocity; Angular Belt Drives; Horsepower transmitted by Ropes; Sheaves for Rope Drive; Bending Stresses in Wire Ropes; Sprockets for Link Chains; Formulas and Tables for Driving Chain.

**No. 20. Wiring Diagrams, Heating and Ventilation, and Miscellaneous Tables.**—Typical Motor Wiring Diagrams; Resistance of Round Copper Wire; Current Densities for Various Contacts and Materials; Centrifugal Fan and Blower Capacities; Hot Water Main Capacities; Decimal Equivalents, Metric Conversion Tables, Weights and Specific Gravity of Metals, Drafting-room Conventions, etc.

MACHINERY, the leading journal in the machine-building field, the originator of the 25-cent Reference and Data Books. Published monthly. Subscription, \$2.00 yearly. Foreign subscription, \$3.00.

The Industrial Press, Publishers of MACHINERY,  
49-55 Lafayette Street, New York City, U. S. A.

