

MACHINERY'S REFERENCE SERIES

EACH NUMBER IS ONE UNIT IN A COMPLETE LIBRARY OF MACHINE DESIGN AND SHOP PRACTICE REVISED AND REPUBLISHED FROM MACHINERY

No. 40

FLY-WHEELS

CONTENTS

Fly-wheels, their Purpose, Calculation and Design, by C. H. BENJAMIN and WILLIAM BURLINGHAM	3
Fly-wheel Tests	21
Safe Speed for Fly-wheels	27
Size, Weight and Capacity of Fly-wheels for Punches, by FRANK B. KLEINHANS	30
Simplified Methods for Fly-wheel Calculations, by R. J. WILLIAMS	41
Fly-wheels for Motor-driven Planers, by W. OWEN	46

MACHINERY'S REFERENCE SERIES

This treatise is one unit in a comprehensive Series of Reference books, originated by MACHINERY, and including an indefinite number of compact units, each covering one subject thoroughly. The whole series comprises a complete working library of mechanical literature in which the Mechanical Engineer, the Master Mechanic, the Designer, the Machinist and Tool-maker will find the special information he wishes to secure, selected, carefully revised and condensed for him. The books are sold singly or in complete sets, as may be desired. The price of each book is 25 cents, and it is possible to secure them on even more favorable terms under special offers issued by MACHINERY'S circulation department and sent to any one on request.

The success of the Reference Series was instantaneous and copies are now widely distributed in machine shops and metal working plants everywhere.

CONTENTS OF REFERENCE BOOKS

No. 1. WORM GEARING.—Calculating Dimensions for Worm Gearing; Hobs for Worm-Gears; Location of Pitch Circle; Self-Locking Worm Gearing; etc.

No. 2. DRAFTING-ROOM PRACTICE.—Drafting-Room System; Tracing, Lettering and Mounting; Card Index Systems.

No. 3. DRILL JIGS.—Elementary Principles of Drill Jigs; Drilling Jig Plates; Examples of Drill Jigs; Jig Bushings; Using Jigs to Best Advantage.

No. 4. MILLING FIXTURES.—Elementary Principles of Milling Fixtures; Collection of Examples of Milling Fixture Design, from practice.

No. 5. FIRST PRINCIPLES OF THEORETICAL MECHANICS.—Introduces theoretical mechanics in a manner suited to the practical man.

No. 6. PUNCH AND DIE WORK.—Principles of Punch and Die Work; Suggestions for the Making and Use of Dies; Examples of Die and Punch Design.

No. 7. LATHE AND PLANER TOOLS.—Cutting Tools for Planer and Lathe; Boring Tools; Shape of Standard Shop Tools; Forming Tools.

No. 8. WORKING DRAWINGS AND DRAFTING-ROOM KINKS.—Principles of Making Working Drawings; Drafting Tools; Draftsmen's Kinks.

No. 9. DESIGNING AND CUTTING CAMS.—Drafting of Cams; Cam Curves; Cam Design and Cam Cutting; Suggestions in Cam Making.

No. 10. EXAMPLES OF MACHINE SHOP PRACTICE.—Cutting Bevel Gears with Rotary Cutters; Making a Worm-Gear; Spindle Construction.

No. 11. BEARINGS.—Design of Bearings; Causes of Hot Bearings; Alloys for Bearings; Ball Bearings; Friction of Roller Bearings.

No. 12. MATHEMATICS OF MACHINE DESIGN.—Compiled with special reference to shafting and efficiency of hoisting machinery.

No. 13. BLANKING DIES.—Making Blanking Dies; Blanking and Piercing Dies; Construction of Split Dies; Novel Ideas in Die Making.

No. 14. DETAILS OF MACHINE TOOL DESIGN.—Cone Pulleys and Belts; Strength of Countershafts; Tumbler Gear Design; Faults of Iron Castings.

No. 15. SPUR GEARING.—First Principles of Gearing; Formulas for Spur Gearing; Design and Calculation of Gear Wheels; Strength of Gear Teeth.

No. 16. MACHINE TOOL DRIVES.—Speeds and Feeds of Machine Tools; Geared or Single Pulley Drives; Drives for High Speed Cutting Tools.

No. 17. STRENGTH OF CYLINDERS.—Formulas, Charts, and Diagrams for Thick Hollow Cylinders; Design of Thick Cylinders; Cast Iron Cylinders.

No. 18. SHOP ARITHMETIC FOR THE MACHINIST.—Tapers; Change Gears;

MACHINERY'S REFERENCE SERIES

EACH NUMBER IS ONE UNIT IN A COMPLETE
LIBRARY OF MACHINE DESIGN AND SHOP
PRACTICE REVISED AND REPUB-
LISHED FROM MACHINERY

NUMBER 40

FLY-WHEELS

CONTENTS

Fly-wheels, their Purpose, Calculation and Design, by C. H. BENJAMIN and WILLIAM BURLINGHAM - - -	3
Fly-Wheel Tests - - - - -	21
Safe Speed for Fly-wheels - - - - -	27
Size, Weight and Capacity of Fly-wheels for Punches, by FRANK B. KLEINHANS - - - - -	30
Simplified Methods for Fly-wheel Calculations, by R. J. WILLIAMS - - - - -	41
Fly-wheels for Motor-driven Planers, by W. OWEN -	46



CHAPTER I

FLY-WHEELS, THEIR PURPOSE, CALCULATION AND DESIGN

The object of all fly-wheels is to equalize the energy exerted and the work done, and thereby prevent great or sudden changes of speed. The extent to which speed changes may take place is the determining factor in all fly-wheel design. The application and use of fly-wheels will, however, be more readily perceived if we examine some concrete practical examples.

In a shear press or punch the energy of the driving belt remains practically constant, but the work done by the jaws varies from practically nothing at the return stroke to the full power of the machine when cutting. In an engine, on the other hand, the work done by the belt wheel may be constant, or nearly so, while the energy exerted by the steam on the piston varies throughout each stroke. Furthermore, in any engine using a connecting-rod and crank, the energy exerted on the crank pin, tending to turn the shaft, varies from nothing at the end of the stroke to its greatest value near mid-stroke. A steam engine without a fly-wheel would, therefore, be useless and could hardly make one single revolution.

Now in what way can a fly-wheel help to overcome this difficulty? If such a wheel of large diameter and with a heavy rim were mounted on ball bearings to reduce the friction, it would even then be found difficult to set it in motion or increase its speed suddenly, on account of its inertia. To give to it any particular increase of speed would require a certain amount of work or energy put into it. Having once acquired speed it would be capable of doing the same amount of work on any opposing body by virtue of this stored energy.

So the fly-wheel of the engine or press, as long as the energy exerted is greater than the work being done, will turn faster, the inertia of its rim absorbing excess of energy. On the other hand, if the energy becomes less than the work, the wheel turns slower and slower, giving up its stored energy to supply the deficiency. The heavier the rim, and the greater its velocity, the less the change of speed for a given storage of energy.

In the steam engine these changes of speed occur twice in every revolution, the wheel moving most slowly near one-quarter stroke and most rapidly near three-quarters stroke, the exact times being dependent on the point of cut-off and the connecting-rod ratio. The use of the fly-wheel is often confused with that of the governor. The fly-wheel can only average the speed during one revolution and prevent violent changes in that time. It has no control over the number of revolutions per minute. On the other hand, no ordinary governor

works quickly enough to regulate the speed in one revolution. The governor prevents any permanent change in speed by adapting the amount of steam admitted to the amount of work to be done. A governor will prevent an engine from running away; a fly-wheel cannot.

Elementary Calculations of Fly-wheels for Steam Engines

In order to determine the weight of rim of a fly-wheel, it is necessary to know the probable excess and deficiency of energy in each stroke and the per cent of variation in speed that can be tolerated. The earlier the cut-off of the engine the greater the variation in energy and the larger the fly-wheel that will be required. The weight of the reciprocating parts and the length of the connecting-rod also affect the variation. The following table from Rankine's "Steam Engine" shows about what may be expected.

TABLE I. CONDENSING ENGINES

Fraction of stroke at which steam is cut off.....	1/3	1/4	1/5	1/6	1/7	1/8
Factor of energy excess.....	0.163	0.173	0.178	0.184	0.189	0.191

TABLE II. NON-CONDENSING ENGINES

Steam cut off at.....	1/2	1/3	1/4	1/5
Factor of energy excess.....	0.160	0.186	0.209	0.232

To obtain the excess of energy from this table it is only necessary to find the average work in foot-pounds done by the engine in one revolution and multiply this by the decimal given in the table. We will call this excess of energy E . The allowable variation in speed depends upon the use to which the engine may be put. In modern engines an allowance of from 1 to 2 per cent is usual.

The following formula is used for computing the weight of the fly-wheel rim:

Let W = weight of rim in pounds,

D = mean diameter of rim in feet,

N = number of revolutions per minute,

1

— = allowable variation in speed (from 1/50 to 1/100),

n

E = excess and deficiency of energy in foot-pounds,

c = factor from Tables I and II,

$H.P.$ = indicated horse-power.

Then, if the indicated horse-power is given:

$$W = \frac{387,587,500 \times cn \times H.P.}{D^2 N^3} \quad (1)$$

If the work in foot-pounds is given, then:

$$W = \frac{11,745 n E}{D^2 N^2} \quad (2)$$

E is calculated as before explained. From these formulas it will be seen that increasing the diameter or the speed of a wheel diminishes

the necessary weight of rim very rapidly. To make clear the use of these formulas, we will work out two examples, such as might arise in practice.

Example 1.—A non-condensing engine of 150 indicated horse-power makes 200 revolutions per minute, with a variation of 2 per cent. The average cut-off is at one-quarter stroke, and the fly-wheel is to have a mean diameter of 6 feet. Required the necessary weight of rim in pounds.

From Table II we find $c = 0.209$, and from the data given we evidently have:

$$H. P. = 150; N = 200; \frac{1}{n} = 1/50 \text{ or } n = 50; D = 6.$$

Substituting these values in equation (1) we have:

$$W = \frac{387,587,500 \times 0.209 \times 50 \times 150}{36 \times 200 \times 200 \times 200}$$

or $W = 2,110$ pounds, nearly.

Example 2.—A condensing engine, 24 x 42 inches, cuts off at one-third stroke and has a mean effective pressure of 50 pounds per square inch. The fly-wheel is to be 18 feet in mean diameter and make 75 revolutions per minute with a variation of 1 per cent. Required, weight of rim.

The work done on the piston in one revolution is equal to the pressure on the piston multiplied by the distance traveled or twice the stroke in feet. The area of the piston in this case is 452.4 square inches, and twice the stroke is 7 feet. The work done on the piston in one revolution is, therefore: $452.4 \times 50 \times 7 = 158,340$ foot-pounds. From Table I, $c = 0.163$, and therefore:

$$E = 158,340 \times 0.163 = 25,810 \text{ foot-pounds.}$$

From the data given we have: $n = 100$; $D = 18$; $N = 75$. Substituting these values in equation (2):

$$W = \frac{11,745 \times 100 \times 25,810}{18 \times 18 \times 75 \times 75} = 16,650 \text{ pounds, nearly.}$$

Dimensions of Rim

In the above formulas, D , the mean diameter of the rim, is really twice the so-called radius of gyration, and would be found by squaring the outer and inner diameters, adding them together, dividing by two and extracting the square root. In symbols this would read:

$$D = \sqrt{\frac{D_1^2 + D_2^2}{2}}$$

It is usually accurate enough to take $D = \frac{D_1 + D_2}{2}$, or the arithmetical mean.

To illustrate, we will assume $D_1=8$, $D_2=9$, then:

$$D = \sqrt{\frac{64 + 81}{2}} = 8.514$$

But the mean of 8 and 9 is 8.5, which is accurate enough in practice. The number of cubic feet in the rim may be found by dividing the weight in pounds by 450 for cast iron or 480 for steel.

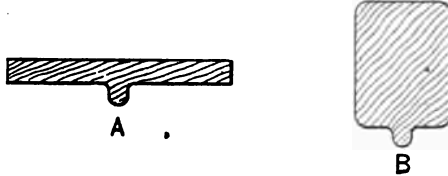

Fig. 1. Types of Fly-wheel Rim Sections

For instance, the rim in the first example given above would contain:

$$\frac{2,110}{450} = 4.69 \text{ cubic feet of cast iron,}$$

and the one in the second example would contain:

$$\frac{16,650}{450} = 37 \text{ cubic feet.}$$

The area of the cross section of the rim may be found approximately by dividing the cubic contents by the circumference corresponding

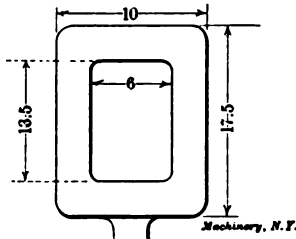

Fig. 2. Hollow Fly-wheel Rim

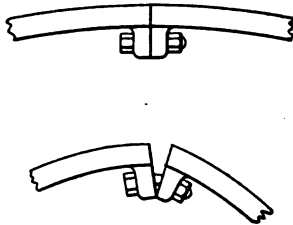

Fig. 3. Manner in which Bolts in Fly-wheel Joints are Stressed

to the mean diameter D . This area, in the first example, would be:

$$\frac{4.69}{6 \times 3.1416} = 0.2487 \text{ square feet} = 35.83 \text{ square inches,}$$

and in the second example:

$$\frac{37}{18 \times 3.1416} = 0.654 \text{ square feet} = 94.2 \text{ square inches.}$$

The shape of the cross-section is determined by the use to be made of the wheel. If it is a belt wheel the width of rim is determined by the width of belt, and the section is usually something like A, Fig. 1.

If the wheel is to be simply a fly-wheel, it is better to adopt a stronger form of section and one easier to fasten at the joints. A common form in such cases is like *B*. In very large wheels it is better to make the rim hollow, as it is easier to cast and easier to put together. To illustrate the above principles, we will assume that the wheel in the first example is to carry a double leather belt sufficiently wide to transmit the desired horse-power. We will say that under the given conditions a belt 18 inches wide would be sufficient.

We may then assume that the rim should be a little wider than this, or say 19 inches.

The thickness will then be:

$$t = \frac{35.83}{19} = 1.88 \text{ inch.}$$

On the other hand, if we assume the wheel in the second example to be used solely as a fly-wheel, we can take any proportions which

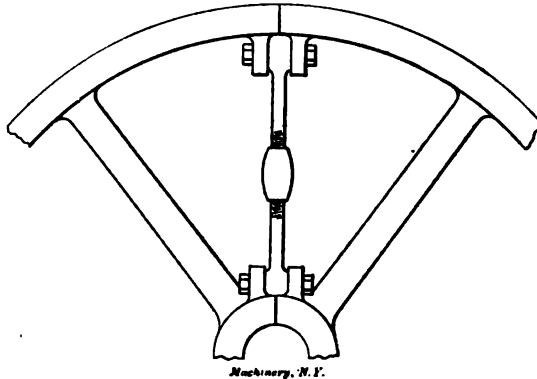

Fig. 4. Fly-wheel Joint Reinforced by Tension Rod

may be convenient. If a width of eight inches is chosen, the depth will be:

$$\frac{94.2}{8} = 11\frac{3}{4} \text{ inches, nearly,}$$

and the wheel will be about 19 feet in outside diameter.

If it is decided to make the rim hollow and a thickness of two inches is adopted, the proportions would be about as in Fig. 2.

Joints in Rims

Wheels less than 8 feet in diameter are usually cast solid. Wheels from 8 to 16 feet in diameter may be cast in halves to facilitate transportation. Wheels larger than 16 feet are usually cast in several pieces, the hub being a separate piece. Each arm may have a segment of the rim cast with it, but in the larger sizes of wheels the segments of the rim are bolted to the arms as well as to each other. The bolts must be kept as snug to the rim and as far from the lower edge of the flange as possible.

Until quite recently it has been customary to join the segments of the rims of belt pulleys by internal flanges and bolts, the joint coming midway between the arms. Theory and experiment both show this to be a very unsafe arrangement, the strength of the joint being only from one-fifth to one-third that of the solid rim. When the wheel is running at a high speed, the pressure of the centrifugal force bends the joint out and opens it as shown in Fig. 3, thus throwing a great additional stress upon both bolts and flanges. If a joint of this type is adopted, it should be strengthened by wrought iron or steel tension rods, running from the flanges to the hub, and preventing the rim from bending at the weak point. (See Fig. 4.) Mr. James Stanwood has suggested placing such a joint at a point one-quarter way from the arm, where the bending is practically nothing. Most engine builders of late have put the joints in the rim directly over the arm. In any case, the bolts should be located as close to the rim as practicable.

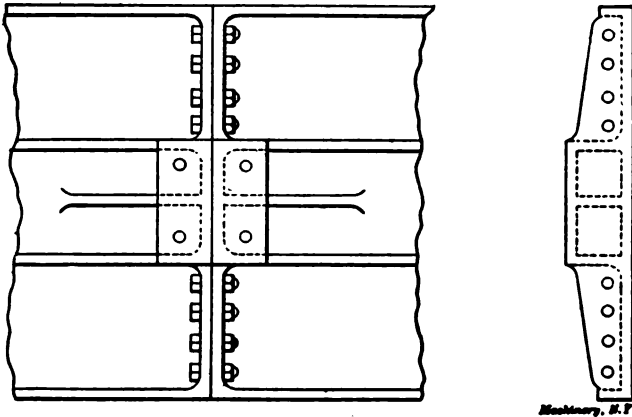

Fig. 5. Joint in Fly-wheel with Wide Face

Fig. 5 shows a joint in a belt wheel rim as made by a well-known firm of engine builders. This is a wheel 24 feet in diameter, with a 64-inch face intended for two belts. The flanges are well braced by the internal ribs, and the bolts which hold the arms also assist in strengthening the rim joint. If a rim of this kind is very wide, the centrifugal force tends to stretch the outer edges of the rim and to crack the cross flanges near the arms. In such cases it were better to use two sets of arms or two separate wheels.

A much safer and better rim, where it can be used, is the narrow and deep form. The tendency of bending between the arms, due to centrifugal force, is then resisted by the great depth of metal. The links or bolts which form the joint can be placed nearer the center of the rim, where the bending will not affect them. Two common forms of such joints are shown in Figs. 6 and 7. The links or prisoners, as they are sometimes called, are let in on the two opposite sides of the rim and occasionally on the inside face as well. They are

usually put in hot and allowed to shrink into place, drawing the joint firmly together.

Experiments made at the Case School of Applied Science, Cleveland, Ohio, have shown that a joint of this kind may have a strength two-thirds that of the solid rim. If the section of the rim is slightly increased where the link is inserted, the strength will be greater. (See Fig. 7.)

In a paper read before the American Society of Mechanical Engineers, Mr. John Fritz has called particular attention to the advantages of the hollow rim and arms in fly-wheel construction. Fig. 8 is a sketch of a joint in such a wheel. The coring of the rim insures a sounder casting and also makes it possible to get a stronger joint, by thickening the metal at that point. The links are made of different lengths so that the heads will not all come at the same point.



Fig. 6



Fig. 7

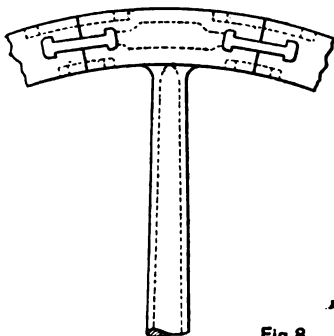

Fig. 8

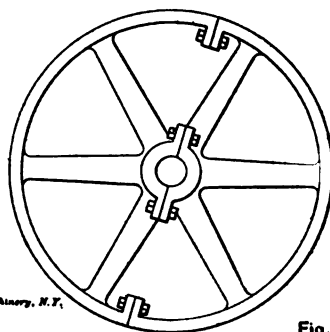

Fig. 9

Figs. 6 to 9. Types of Fly-wheel Rim Joints

It is not possible to give any definite rule for determining the width and thickness of fly-wheel arms, there being so many disturbing factors. The thickness of the metal should be as uniform as possible, and where the arm joins the rim, if cast on, the change of thickness should be gradual, to avoid cooling strains. Increasing the number of arms will strengthen the rim by diminishing the bending between the arms. Under ordinary circumstances the stresses on the arms of a fly-wheel are slight, but when started or stopped suddenly, as in rolling-mill work, it is difficult to calculate how great they may be.

Experiments made on ordinary belt pulleys have shown that the bending due to belt tension is not evenly distributed among the arms, but is almost twice as great on the arm which happens to be nearest to the tight side of the belt at any instant. This difference is probably less in fly-wheels, on account of their stiffer rims, but even here it would be preferable to design the arms for about twice the average moment.

Examples

Example 3.—It is required to design an internal flange joint for a fly-wheel rim 3 inches thick and 18 inches wide, the wheel being 10 feet in diameter and built in two halves.

A simple design in such a case is to part the wheel on a diameter which shall pass near two of the arms, as in Fig. 9. The distance from the joint to the center of the arm should not be more than one-quarter the space between the arms. The flanges should be of approximately the same thickness as the rim. We will use steel bolts having a tensile strength of 75,000 pounds per square inch. If the metal in the rim has a tensile strength of 18,000 pounds per square inch, the

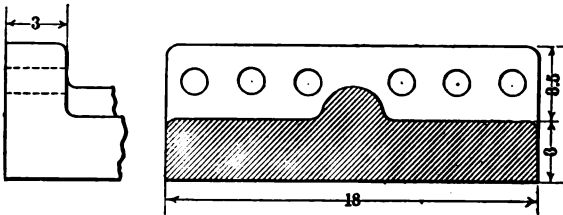

Fig. 10

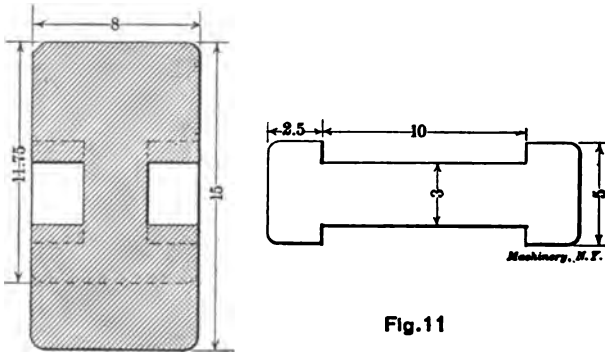

Fig. 11

Figs. 10 and 11. Fly-wheel Rim Joints

total tensile strength of the rim is $3 \times 18 \times 18,000 = 972,000$ pounds. It will be found difficult to make the strength of joint more than one-third this, or 324,000 pounds.

$$\frac{324,000}{75,000} = 4.32 \text{ square inches of bolt area required.}$$

Six $1\frac{1}{4}$ -inch bolts will have a combined area at the root of thread of $6 \times 0.89 = 5.34$ square inches.

With bolts even as large as this, the flange will probably break before the bolts. The joints would have the appearance shown in Fig. 10. The bolts should be kept as snug to the rim and as far from the lower edge or flange as possible.

Example 4.—Let it be required to design a link joint for the rim of

the wheel in Example 2, supposing the rim to be solid, 8 inches wide and 11.75 inches deep.

Assuming the tensile strength of the cast iron as 18,000 pounds per square inch, the total strength of rim is:

$$8 \times 11.75 \times 18,000 = 1,692,000 \text{ pounds.}$$

If the tensile strength of the steel used for links is taken as 75,000 pounds per square inch, and we try to make the joint two-thirds as strong as the rim, we shall need:

$$\frac{2}{3} \times \frac{1,692,000}{75,000} = 15 \text{ square inches.}$$

If we adopt the form of joint shown in Fig. 7 and use two links,

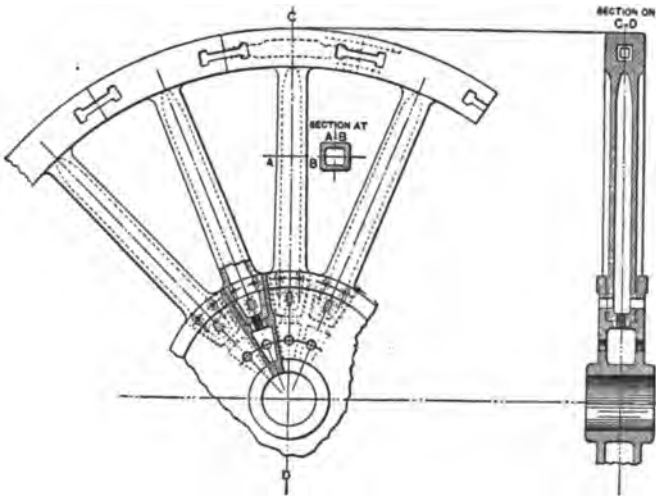

Fig. 12. Fly-wheel for Rolling Mill Service

the area of cross-section of each link will be 7.5 square inches, or 2.5×3 inches. Fig. 11 shows the proportions of such a joint. As the heads of the links will remove $2 \times 2.5 \times 5$, or 25 square inches of metal from the cross-section of the rim, it will be necessary to add this amount by increasing the depth at the joint to about 15 inches.

Types of Fly-wheels

The ordinary fly-wheel used in this country is built of cast iron; many serious accidents from the bursting of these wheels have occurred because of bad design, hidden flaws, or because the wheels were run at higher than their designed speed.

The fly-wheel recommended by Mr. John Fritz, and already referred to, is shown in detail in Fig. 12. This wheel is the outgrowth of the demands of rolling-mill practice, where the duty of fly-wheels is exceptionally severe.

Referring to the illustration, it will be seen that the segment is cast hollow, and also the arms, which are made at the ends to compare

in thickness to the segment, so as to relieve them of strains which might occur if the segments were cast solid. The holes in the segments are small at the ends, so as to make up for the metal taken out for the tees. The links, or tees, are of different lengths, so that the strain on the segments will not come all at one place, and by using oil-tempered steel in the links, or double tees, the rim will be practically as strong at the joints as it is elsewhere. There are no abrupt changes in the thickness of the castings, thus avoiding as much as possible the liability of strains.

It will be noticed that there is a space in the center of about one-quarter inch in the front and rear side of each arm. This is filled with oakum and driven hard, after the wheel is finished and in place, to keep the arm from yielding in the direction of the strain, and at the same time it greatly lessens the work of fitting up the wheel. The one and three-quarter inch round holes through the center and arm are reamed out and steel pins made and turned so that they will drive in snugly.

Sixty-ton Fly-wheel

A 19-foot fly-wheel of special and interesting construction, which was built in 1905 by the Nordberg Engineering Co., Milwaukee, Wis., for a mine pumping engine operated by the Calumet & Hecla Mining Co., is shown in detail in Fig. 13. The wheel weighs 120,000 pounds and is designed to run at 107 revolutions per minute which means a peripheral speed of nearly 6,400 feet per minute. A reasonable factor of safety for this speed requires a construction considerably stronger than possible with the usual plain form of cast iron fly-wheel. The nominal safe speed limit for cast iron wheels is put at about 5,000 feet per minute but the jump to 6,400 feet means that the bursting stress is increased in the ratio of 2.5 to 4.1. It might be argued that reversing rolling-mill fly-wheels which are subjected to tremendous shocks by reason of constant reversals are made of plain cast iron construction and stand up to the work with very few failures, but this argument would be made without taking into consideration the great increase of centrifugal force incident to increasing the speed even as little as 10 per cent. Between the reversing rolling-mill fly-wheel running at say 4,000 feet per minute and this wheel running at 6,400 feet per minute, the centrifugal stress, which increases as the square of the velocity, as is evident in the formula for centrifugal force, $F = 0.000341 WRN^2$, changes the factor of disruptive stress in the ratio of 1.6 to 4.1. The stress on the reversal does not directly affect the integrity of the rim, but does throw a heavy bending stress on the spokes, hence the part of a reversing fly-wheel which is most affected at reversing is the spokes and not the rim. Therefore, the comparison between the plain reversing mill fly-wheel and the reinforced wheel forming the subject of this description should be made on the basis of speed alone and not with reference to the effect of reversal.

The Calumet & Hecla wheel is made up of two cast iron segments forming the wheel center. These segments are held together by two

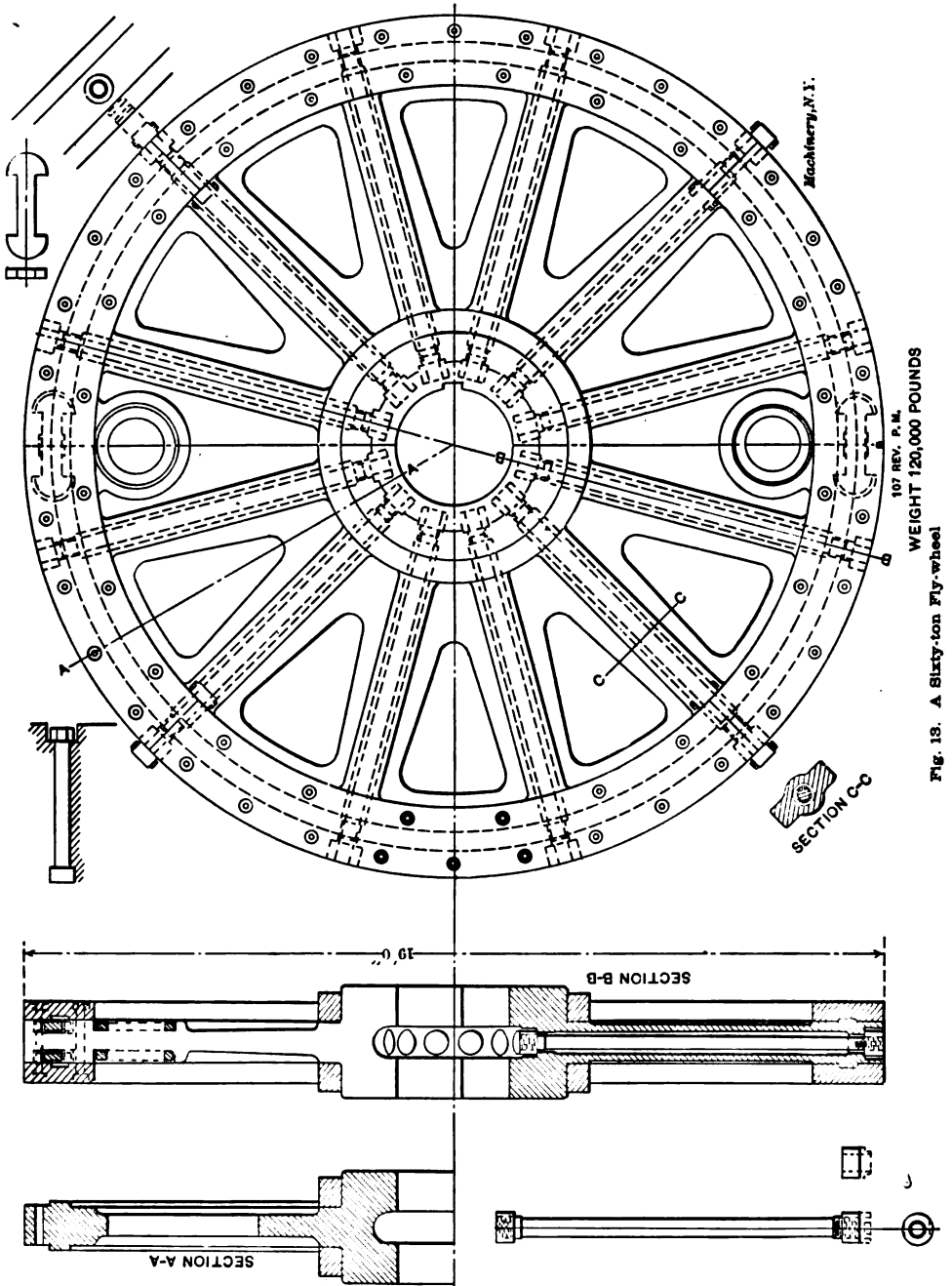

steel shrink rings on the hub, four shrink rings under the rim and two steel rim rings made in halves and secured to the sides of the cast iron rim of the wheel center by 58 bolts 2 inches diameter and 18 inches long. In addition the halves of the wheel center are bound together by four T-head steel links set in the pockets underneath the rim rings and shrunk on in the usual manner. The spokes are cast hollow and 12 open-hearth steel bolts 5 inches diameter are set radially therein, being secured at the ends by round nuts fitting in counter-sunk seats. These bolts are warmed up before being put in place and the nuts are screwed up tightly before cooling, thus getting a heavy compression effect on the spokes due to the contraction of the bolts, the intention of the designer being to relieve the cast iron parts of all tensional strain due to centrifugal force. The spokes of the cast iron

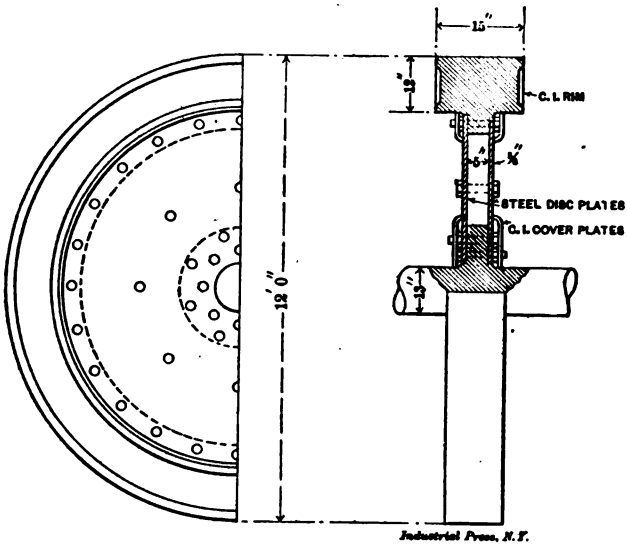

Fig. 14. An Unusual Fly-wheel Design

wheel center have an open space between each pair save at the junction of the halves where the web is made solid, having a thickness of 7 inches next the hub. A boss is cast on each side under the rim in which an annular seat is machined with a boring bar for four steel shrink rings which bind the two halves together, as mentioned. The rim rings are steel castings and provided with lugs for bolting together for the boring and facing operations in the boring mill. After being bolted to the sides of the cast iron center, the lugs are chipped off, leaving a smooth surface.

Fig. 14 shows a novel type of wheel suitable for the severe work of a traction plant. It is used on a 600 kilowatt set for power and lighting in the works of Messrs. Workman, Clark & Co., Ltd., Belfast. The diameter is 12 feet and the advantages claimed for it, which seem correct, are as follows:

The rim is continuous, and the strength maintained, therefore, practically to the full. The number of bolts in the rim being much more numerous than spokes, the stresses that occur, due to the bending of the rim between the points of support, are correspondingly less. The steel disks connecting the rim with the hub are made very strong to resist the great torques of sudden changes of speed, a very important matter in a fly-wheel for electric traction. It is exceedingly cheap to make. The stresses in the arms, due to the cooling and shrinkage of a cast iron wheel are absent from a wheel of this type.

If a larger wheel of this type were made, it could be made with the rim in sections, when all the above advantages would obtain, except the first. Another type of wheel, claimed to have been originated by Prof. Sharp, is shown to the left in Fig. 15.

Steel wire of great tensile strength is wound around the periphery

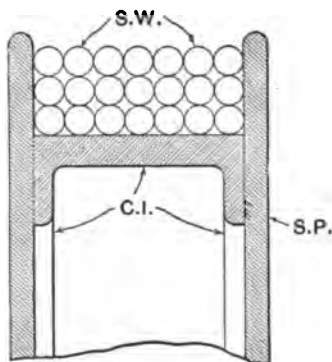

CROSS SECTION
 S.W. — Steel Wire
 S.P. — Steel Plates
 C.I. — Cast Iron

Fig. 15. Fly-wheel having a Steel Wire Rim

of the wheel. With a well-made wheel of this type it is practically safe to run it at three times the velocity of an ordinary cast iron wheel. Hence it would store nine times the energy for the same weight, at the same radius of gyration, as a cast iron wheel.

A wheel of this type is used at the Mannsmans Tube Works. About 70 tons of steel wire was wound on the wheel with a tension of about 50 pounds. The fly-wheel was 20 feet in diameter and ran at 240 revolutions per minute, equal to a peripheral speed of about 250 feet per second. The speed of a cast-iron wheel of the same diameter would be about 100 feet per second.

Danger of Fly-wheels Bursting

As regards the danger of fly-wheels bursting, Professor Barr states that it is not realized how dangerous they are, and mentions a case in point. It was on an experimental engine. The makers of the fly-wheel, on which an experimental brake was used, had, contrary to his

wishes, and entirely on their own responsibility, made the fly-wheel with a hub solid with the arms and rim. One evening, during the run, a report like a gunshot was heard and the observers noticed that the flywheel was running out of true. The rim of the wheel was just warm, about as warm as one's hand. The engine was stopped and they found three of the arms out and six broken. The middle one was open about $\frac{3}{32}$ of an inch. There must therefore have been an enormous initial stress in the arms. There were two fly-wheels on the engines and the makers were told that they must replace both. They said they would replace the broken one with a new one having a split boss and cut the boss of the other wheel in two. They were warned as to what would happen, but they put the wheel in a slotting machine, and before they had cut half way through one side of the boss, the stresses of the wheel completed the job in a manner astonishing to the man running the slotter.

Great care must be taken regarding test specimens, as a test specimen cast from the same melting as the wheel does not necessarily indicate the same strength as that in the wheel. Test specimens vary also according to the way they are cast, so that a high factor of safety must be allowed in all cast wheels—say from 12 to 15.

Mr. C. A. Matthey, Scotland, says that, considering the ultimate strength of British cast iron as 16,000 pounds, it is safe to assume a factor of safety of 8, with a speed of 140 feet per minute, the arms to be cast with the rim but without the hub, thus avoiding cooling stresses, the hub being conscientiously fitted afterwards. This involves entering the arms sideways and not radially into pockets in the hub. He thinks that the attachment of the arms to the rim, when separate from solid rims, should be such as to drive the rim around without pulling it in toward the center. Let the rim support itself by its own tensile strength without radial pressures at a number of points.

The strength necessary in the arms of a fly-wheel has little if anything to do with the centrifugal force, and their sections should be proportioned to the driving moments they exert in storing up energy in the rim and in re-delivering it to the shaft. In certain kinds of engine service a good rule is to make the fly-wheel arms strong enough to pull up the wheel from full speed to a dead stop in one revolution.

From Mr. Marshall Downie's paper in *Transactions of the Institute of Engineers and Shipbuilders* (Scotland), the following is quoted: "The combined cross-sectional area of the arms in well designed wheels of the type used for electric traction, etc., is generally from two to three times the cross section of the rim. The strength of the arms as beams, fixed at the inner end and loaded at the outer end, with the force required to produce an acceleration, either plus or minus, in the mass of one segment, while changing the velocity through the limits specified in the time elapsing between two consecutive points of coincidence of actual and mean crank effort lines, should also be considered; and this, together with the resistance to shearing by the same load, should not tax the material above one-eighth of its ultimate load."

The fixing of the arms to the hub is usually by means of bolts or

cotters and their strength in double shear should be equal to that of the arm in shear or tension, whichever is greater.

Fly-wheel Rim Joints

Several forms of rim joints are in use for fly-wheels. Among the principal ones are the following: (a) flanged and bolted; (b) dowel plate and cotters; (c) arrow-headed bolts; (d) links and lugs. As illustrated in Fig. 16, the following points must be observed:

(a.) In flanged and bolted joints, the bolts should be as near the rim as possible, consistently with getting a deep flange. The bolts should be carefully fitted at each end and cleared in the center, so that the stress on them should be tensile rather than shearing. They should all be initially stressed by screwing up, if possible to the same amount.

(b.) The accurate machining and fitting of the dowel plate and cot-

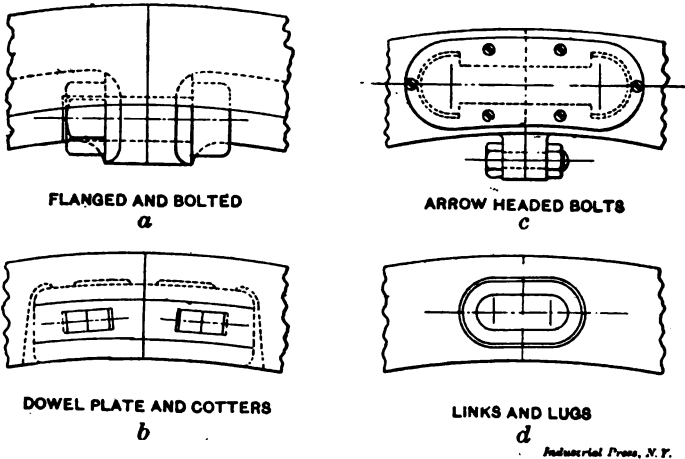

Fig. 16. Additional Types of Rim Joints

ter joint is most important. It should be so designed that the strength of the cast-iron, cotters and portion of the dowel plate in shear is equal to the strength of the portion of the dowel plate in tension. The accuracy with which the initial stress in this form of joint can be adjusted is an important feature in its favor.

(c.) The arrow-headed bolt joint is a shrunk joint, and is open to the objection that the initial stress on the bolts due to the shrinkage is a more or less unknown quantity and the ultimate stress, therefore, indeterminate. The points to be attended to in its construction are accurate machining between the lugs on the bolts and rim, and provision for clearance at the center, for the same reason as noted in (a).

(d.) The link and lug joint is also a shrunk joint and subject to the same objections as (c) on that score. If made with the lug projecting, as shown in the figure, it has the advantage that the section of the rim is not diminished at the joint. The increase of weight, however,

which such a form necessitates, is a good reason for removing the position of the joint nearer one arm. From the experiments of Prof. C. H. Benjamin reported in the *Proceedings of the American Society of Mechanical Engineers* and from the workings of the engines of the Metropolitan Street Railway, Dr. Downie has drawn the following conclusions:

A good average value for the energy necessary to be stored in fly-wheels for electric lighting purposes is 2.9 foot-tons per electric horsepower; and in traction plants, 4 foot-tons.

Where practicable, cast-iron fly-wheels should have one-piece rims, but when jointed the best form is the link and lug type, where such can be adopted without inconvenience, and the next best is the dowel plate and cotter. Flanged and bolted joints should be avoided and the best place for a joint is near one arm.

One-piece rim cast iron fly-wheels may be run at a peripheral speed of 100 feet per second with the certain knowledge that the factor of safety is not under 12, and link-jointed wheels may also be run at that speed and have a factor of safety of 8. A lower factor of safety should not be used, and flange-jointed wheels should not be run above 70 to 75 feet per second. Built steel wheels may be run up to 130 feet per second. Arms should be joined to rim with large fillets and their fixing to the hub should be carefully fitted.

The best material of its kind should be used in the construction and homogeneity should be insured as far as practicable by having test bars from each segment cast and examined.

Stresses in Fly-wheel Rims

The stress tending to cause rupture in a fly-wheel rim depends solely on the rim velocity, and is independent of the radius of the fly-wheel. This can be proved in the following manner:

The sum of the centrifugal (radial) forces of the whole rim of a fly-wheel is

$$F = \frac{W v^2}{g R} = \frac{4 W \pi^2 R r^2}{3600 g} = 0.000341 W R r^2,$$

where F = centrifugal force, in pounds,

W = weight of rim in pounds,

v = velocity of rim in feet per second,

g = 32.16,

R = mean radius of rim in feet,

r = revolutions per minute.

The resultant of half of this force tends to disrupt one-half of the rim from the other half. The rupture is resisted by the two sections of the rim at each end of the diameter. The resultant of half the radial forces is to the sum of half of the radial forces as the diameter of the fly-wheel is to half its circumference, or

$$\frac{\text{resultant}}{\text{sum of half the radial forces}} = \frac{1}{\frac{1}{2} \pi};$$

$$\text{resultant} = \frac{2}{\pi} \times \text{sum of half of the radial forces} = \frac{2}{\pi} \times \frac{0.000341 W R r^2}{2}$$

$$= 0.00010854 W R r^2.$$

As this resultant force is resisted by the section at each end of the diameter, each section must resist a force

$$S = \frac{0.00010854 W R r^2}{2} = 0.00005427 W R r^2.$$

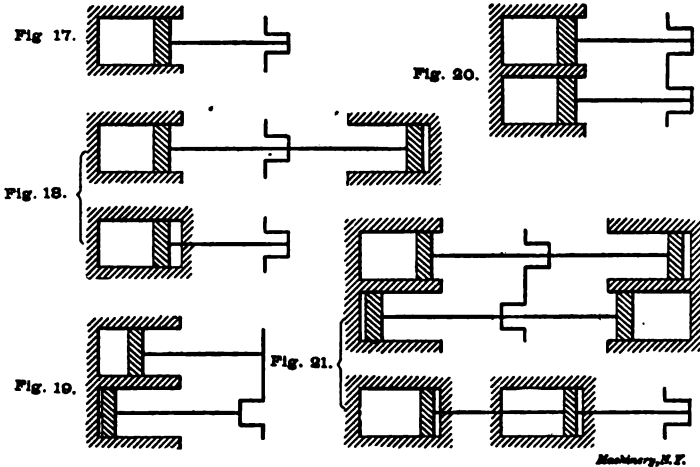

Figs. 17 to 21. Diagrams of Different Types of Gas Engines

The weight of a rim of cast iron, one square inch in section, is $2 \pi R \times 3.125 = 19.635 R$ pounds, R being in feet. Consequently

$$S = 0.00005427 \times 19.635 R \times R r^2 = 0.0010656 R^2 r^2.$$

But as $v = \frac{2 \pi R r}{60}$, and $v^2 = \frac{4 \pi^2 R^2 r^2}{3600}$, we have

$$S = \frac{0.0010656 v^2 \times 3600}{4 \pi^2} = 0.0972 v^2.$$

Thus the stress S in the fly-wheel rim is independent of the radius and depends only on the rim velocity.

Formula for Gas Engine Fly-wheels

The following formula for the calculation of fly-wheels for gas engines is applied by Mr. R. E. Mathot to all classes of engines. If, in the formula,

- P = the weight of the rim (without arms or hub) in tons;
- D = diameter of the center of gravity of the rim in meters;
- a = the amount of allowable variation;
- n = the number of revolutions per minute;
- N = the number of brake horse-power;
- K = coefficient varying with the type of engine:

then, $P = K \frac{N}{D^2 a n^3}$.

If D is transformed to feet, the formula will read:

$$P = K \frac{10.75 N}{D^2 a n^3}$$

The coefficient K , which varies with the type of engine, is determined as follows:

$K = 44,000$ for Otto-cycle engines, single-cylinder, single-acting, (Fig. 17.)

$K = 28,000$ for Otto-cycle engines, two opposite cylinders, single-acting, or one cylinder double-acting. (Fig. 18.)

$K = 25,000$ for two cylinders single-acting, with cranks set at 90 degrees. (Fig. 19.)

$K = 21,000$ for two cylinders, single-acting. (Fig. 20.)

$K = 7,000$ for four twin opposite cylinders, or for two tandem cylinders, double-acting. (Fig. 21.)

The factor a , the allowable amount of variation in a single revolution of the fly-wheel is as follows:

- For ordinary industrial purposes..... 1/25 to 1/30
- For electric lighting by continuous current..... 1/50 to 1/60
- For spinning mills and similar machinery..... 1/120 to 1/130
- For alternating current generators in parallel..... 1/150

The total weight of the fly-wheel may be considered as equal to $P \times 1.4$.

CHAPTER II

FLY-WHEEL TESTS

Fly-wheels do not often break from faults of construction or material, but from a sudden increase of speed due to some accident. Most fly-wheels that fail are really sound and safe under ordinary conditions. The fact that a defective wheel may run for years and then suddenly burst, shows that the immediate cause was not the defects, but some change from the normal condition under which the wheel had been running. Wheels do not often fail from torsional stress or from twisting action in pulling their load, because enough material can be put in the wheel to resist successfully any load required of the engine. There is, however, no possible way to overcome the centrifugal force due to speed. Increasing the thickness of the rim of the wheel does not strengthen it so far as centrifugal force is concerned, because the weight added also increases the centrifugal force, leaving the wheel no stronger than before. There is, therefore, a definite speed at which any wheel, however sound, will explode, regardless of the amount of material it contains.

For cast iron wheels sound theory borne out by good practice has fixed *a mile a minute* as the danger limit for the rim speed. Most wheels are run at or near this speed. The normal speed, however, is only of incidental consideration, as an accident may at any moment allow the speed to get beyond the normal. As the stress in the rim due to centrifugal force increases with the *square of the speed*, disruption quickly follows even a slight increase in speed. If the speed should be accidentally tripled, for example, the stress in the rim would become *nine times* as great as before, and the wheel would have exploded long before it had attained that speed. As a matter of fact, the percentage of fly-wheels that explode is 33 per cent greater than the percentage of boilers that explode.

Fly-wheel Tests at the Case School of Applied Science

For several years tests have been conducted at the Case School of Applied Science, Cleveland, Ohio, to find the relative strength of fly-wheels of different designs and proportions, and the results of these form the best data we have upon the strength of such wheels at the present time. The tests were made upon small model wheels, 15 inches to 2 feet in diameter, run at enormously high speeds by means of a steam turbine, until they finally burst. Apparatus was provided for recording the speed at the time of bursting. At the annual meeting of the American Society of Mechanical Engineers in 1898, Prof. C. H. Benjamin gave the results of the tests made up to that time and drew the following conclusions:

- 1.—Fly-wheels with solid rims, of the proportions usual among engine

builders, and having the usual number of arms, have a sufficient factor of safety at a rim speed of 100 feet per second, if the iron is of good quality and there are no serious cooling strains. In such wheels the bending due to centrifugal force is slight and may be safely disregarded.

2.—Rim joints midway between the arms are a serious defect, and reduce the factor of safety very materially. Such joints are as serious mistakes as would be a joint in the middle of a girder under a heavy load.

3.—Joints made in the ordinary manner, with internal flanges and bolts, are probably the worst that could be devised for the purpose. Under the most favorable conditions they have only about one-fourth the strength of the solid rim and are particularly weak against bending. In several joints of this character on large fly-wheels, calculation shows a strength less than one-fifth that of a solid rim.

4.—The type of joint having the rim held together with links is probably the best that could be devised for narrow rimmed wheels not intended to carry belts, and possesses, when properly designed, a strength about two-thirds that of the solid rim.

At the 1901 meeting of the society, Prof. Benjamin gave some additional data, deduced from experiments conducted since 1898. Wheels with solid rims were again tested, to afford a standard for comparison by which wheels with jointed rims of various designs could be judged. These burst at a rim speed of 395 feet per second, corresponding to a centrifugal tension of about 15,600 pounds per square inch.

Four wheels were tested with joints and bolts inside the rim, after the familiar design ordinarily employed for band wheels, but with the joints located at points one-fourth of the distance from one arm to the next, these being the points of least bending moment, and, consequently, the points at which the deflection due to centrifugal force would be expected to have the least effect. The tests, however, did not bear out this conclusion. The wheels burst at a rim speed of 194 feet per second, corresponding to a centrifugal tension of about 3,750 pounds per square inch. These wheels, therefore, were only about one-quarter as strong as the wheels with solid rims, and burst at practically the same speed as wheels in the previous series of tests in which the rim joints were midway between the arms. This is doubtless due to the fact that the heavy mass of the flanges and bolts locates the bending moment near them. In these wheels the combined tensile strength of the bolts in the flange joints was slightly less than one-third the strength of the rim, which is about the maximum ratio possible with this style of joint.

Another type of wheel with deep rim, fastened together at the joints midway between the arms by links shrunk into recesses, after the manner of fly-wheels for massive engines, gave much superior results. This wheel burst at a speed of 256 feet per second indicating a centrifugal tension of about 6,600 pounds per square inch.

Tests were made on a band wheel having joints inside the rim, midway between the arms, and in all respects like others of this

design previously tested, except that tie rods were used to connect the joints with the hub. It burst at a speed of 225 feet per second, showing an increase of strength of 30 to 40 per cent over similar wheels without the tie rods. Several wheels of special design, not in common use, were also tested, the one giving the greatest strength being an English wheel, with solid rim of I-section, made of high-grade cast iron and with the rim tied to the hub by steel wire spokes. These spokes were adjusted to have a uniform tension by "tuning," and the wheel gave way at a rim speed of 424 feet per second, which is slightly higher than the speed of rupture of the solid rim wheels with ordinary style of spokes.

The Bursting of a Four-foot Fly-wheel

At the December, 1904, meeting of the American Society of Mechanical Engineers, Prof. Benjamin read a paper regarding further fly-wheel tests. This time the tests were made on fly-wheels four feet in diameter. To insure safety to the students and to the building of the Case School of Applied Science, these tests were conducted outdoors, in consequence of which they nearly proved disastrous to the neighbors. The fly-wheels were run in a casing of steel castings, located in a pit lined with brick. The flanges of the lower half rested on brick piers and were bolted in place. The entire upper half of the casing could be hoisted up, giving access to the interior for hoisting or removing the wheels. Two wheels were broken successfully, but the third one burst through its bounds and carried the casing with it many feet in the air. Fortunately, every precaution for safety had been taken, all the observers being located far away from the plane of rotation of the wheel.

In carrying out these experiments, the shaft supporting the wheel to be tested turned in bearings bolted to angle irons on the lower halves of the side plates, and was connected to the driving mechanism just inside the building by a flexible sleeve coupling. After the wheel was in place, the casing was lined with wooden blocks to absorb the momentum of the flying fragments. Instead of using a steam turbine as in former experiments, the fly-wheel shaft was speeded up by means of a Reeves variable speed countershaft, interposed between line-shaft and driving-shaft.

The first wheel to be experimented on was a well-proportioned cast-iron pulley, such as is used on shafting for transmitting power. This pulley was 48 inches in diameter, had six arms and weighed 194 pounds. The rim was whole and was $8\frac{1}{2}$ inches wide and about $\frac{3}{8}$ inch thick, finished on the outside. The arms were elliptical in section, $3\frac{1}{4}$ inches by $1\frac{1}{16}$ inch at the hub, and 2 inches by $\frac{3}{4}$ inch at the rim. On the whole the wheel was well-designed and showed no signs of shrinkage strains. It had, however, been balanced in the customary manner by riveting a cast-iron washer inside the rim at the lighter side, and this proved its undoing. The combination of a thin place in the rim, a rivet hole and heavy mass of cast iron is enough to wreck any wheel.

As has been shown by previous experiments on whole rim wheels of cast-iron, a bursting speed of 400 feet per second may be reasonably expected. The circumference of a four-foot wheel being about $12\frac{1}{2}$ feet, such a wheel should burst at about 32 revolutions per second, or 1,920 revolutions per minute. The pulley in question burst at 1,100 revolutions per minute, as recorded by a tachometer connected to the driving-shaft. The balance weight weighed $3\frac{1}{2}$ pounds, and its center was approximately 23 inches from the axis of rotation. At 1,000 revolutions per minute the centrifugal force of the balance weight alone would be 2,760 pounds. Add this radial pressure at a weak point between the arms to that due to the weight of the rim itself, and the low bursting speed is easily accounted for. The linear speed of the rim at rupture was 230 feet per second. As 100 feet per second is considered the limit for belt speed, this pulley would have a working factor of safety of $(2.3)^2$ or 5.3. But suppose the rim had been a little thinner and consequently a bigger weight had been put on with a larger rivet?

Wheel No. 2 was a cast-iron pulley of the same general style and dimensions as No. 1, but with a split hub and rim. The balance-weight was present here as in the former case, but was obliged to yield the palm to its rival, the flanged joint. The wheel had been cast in one piece, as is usual in such cases, with cavities cored at the joints of rim and hub. After finishing, it had been broken apart by wedges, making a fracture joint. The flanges, being located midway between the arms and bolted at some little distance inside the rim, were in the worst possible position to withstand the bending action due to centrifugal force, and their own weight only aggravated the difficulty. The flanges weighed with their bolts $7\frac{1}{2}$ pounds. This wheel burst at less than 700 revolutions per minute, the tachometer not recording below this speed. It was estimated that the speed was only about 600 revolutions per minute. At this speed the centrifugal force of the flanges on one side would have been 1,680 pounds. At 600 revolutions per minute the linear speed of rim would be only 125 feet per second. At the very common belt speed of 4,500 feet per minute the factor of safety would be but 2.8, which is altogether too low, considering the nature of the material and the shocks to which a pulley may be exposed.

It was reserved for wheel No. 3 to develop the most dramatic series of incidents of any yet experimented upon, big or little. This wheel measured 49 inches in external diameter and weighed about 900 pounds. The rim was $6\frac{3}{4}$ inches wide and $1\frac{1}{8}$ inch thick, and was built of ten segments, the material being steel casting. Each joint was secured by three prisoners of an I-section on the outside face, by link prisoners on each edge, and by a dove-tailed bronze clamp on the inside, fitting over lugs on the rim. The arms were of phosphor bronze, twenty in number, ten on each side, and were a cross in section. These arms came midway between the rim joints and were bolted to plane faces on the polygonal hub. The rim was further reinforced by a system of diagonal bracing, each section of the rim being sup-

ported at five points on each side, in such a way as to relieve it almost entirely from bending. The braces, like the arms, were of phosphor bronze, and all bolts and connecting links of steel. This wheel was designed by a Baltimore firm as a model of a proposed 30-foot fly-wheel.

On account of the excessive air resistance it was found necessary to enclose the wheel at the sides between sheet-metal disks, before any great speed could be attained. Even then repeated trials failed to reach a speed of more than 800 or 900 revolutions per minute on account of the great inertia of the wheel, and the consequent slipping of belts. By putting on more and wider belts, and by a liberal use of "Cling-Surface" and with the aid of a $7\frac{1}{2}$ horse-power electric motor belted on in parallel, it was found possible to get a speed of 1,650 revolutions per minute, and after the wheel had been run at this speed it was stopped and examined.

The inspection showed fracture of several of the I-shaped prisoners on the outer surface of the joints and a slight opening of the joints themselves, to the extent of perhaps one or two hundredths of an inch. On June 2, 1903, the casing was closed for the last time, and the combination of driving mechanisms set to work. The observers were all well protected by the thick piers of the building, while other spectators were kept at a safe distance and well away from the plane of rotation. Two of the observers watched the pointer of the tachometer through opera glasses, another kept the time, while a fourth manipulated the driving levers.

As the hand of the speed counter reached and slowly passed the 1,600 mark, the feeling of suspense on the part of those watching reached the acute stage. The pointer crept slowly on and when it quivered on the mark of 1,775, there was a sudden crash, a sound of rending and tearing, and the observers saw the countershaft inside writhing on the floor like a wounded snake. On stepping outside they were saluted by a shower of falling splinters and fine debris, and were surprised—putting it mildly—to note the disappearance of the greater part of casing and wheel.

The steel rim of the casing was broken about six inches below one of the flanges, and the entire upper half weighing half a ton was projected about 75 feet into the air and landed some hundred feet away on the campus. On its way up it carried away part of the cornice of the building, and this collision was probably what caused it to deviate so much from a vertical path. The hub and main spokes of the wheel remained nearly in place, but parts of the rim were found two hundred feet away, while one large fragment landed on the roof of the building.

This sudden failure of the rim casing was unexpected, as it was thought the flange bolts were the parts to give way first. The tensile strength of the casing at the point of fracture was about 1,200,000 pounds, or about four times the strength of the wheel rim at a solid section. Examination of the break in the casing showed a clean, bright fracture, with almost no imperfections.

The failure of the wheel itself was due to a gradual opening of the joints, occasioned by the fracture of the outside prisoners, and to flaws in the bronze castings of the arms near their junction with the rim. On putting the pieces of the wheel together in their original order it was easy to locate the joint which first gave way, on account of the symmetry of the breaks either side of a diameter through this point. It is but fair to the builders of the wheel to say that the fractures showed uniformity of strength and of workmanship, since there was hardly a member or a joint which did not fail in one part of another of the wheel.

One thousand seven hundred and seventy-five revolutions per minute means a linear speed of rim of 22,300 feet per minute, or 372 feet per second would be 645,000 foot-pounds. Further assuming that none of rim of good design, but it is greater than the speed of any sectional or jointed rim which has been tested. The tensile stress due to the centrifugal force at this speed is 13,800 pounds per square inch. This shows that the joints were much weaker than the solid rim. On the whole, the test of this particular wheel was disappointing, since its strength was not sufficient to repay one for the expense of the design.

It is interesting to compare the kinetic energy of the rim of the wheel at the recorded speed with the work of destruction. Assuming the rim with its lugs, flanges, etc., to weigh 300 pounds, which is a reasonable estimate, the kinetic energy at a speed of 372 feet per second would be 645,000 foot-pounds. Further assuming that none of the energy was dissipated in heat, and that the combined mass of wheel and casing projected into the air weighed 1,500 pounds, we find the height of projection to be 430 feet.

CHAPTER III

SAFE SPEED FOR FLY-WHEELS

The following is an abstract from an article by Mr. William H. Boehm, in the *Monthly Bulletin of the Fidelity and Casualty Company*. It is a well understood fact that while an engine pulley or fly-wheel can be designed to successfully resist the torsional stresses due to any load required of the engine, there is no possible way to overcome the centrifugal force due to speed. For a given material there is a definite speed at which disruption will occur regardless of the amount of material used. This is not an uncertain theory, but a mathematical truth easily demonstrated, and is expressed by the following formula:

$$V = 1.6 \sqrt{\frac{S}{W}}$$

in which V is the velocity of the rim of the wheel in feet per second at which disruption will occur, W the weight of a cubic inch of the material used, and S the tensile strength per square inch of the material.

In words the formula means that if we divide the tensile strength of the material by its weight per cubic inch, extract the square root of the quotient and then multiply this by 1.6, the result will be the rim speed in feet per second at which disruption will occur. If instead of the ultimate strength of the material we take its safe strength, the result will be the rim speed in feet per second at which the wheel may be run with safety; the supposition so far being, however, that the rim is made solid in one piece of homogeneous material and free from shrinkage strains.

Applying the formula to determine the safe rim speed for cast iron wheels made in one piece, we would assume that, if the ultimate strength of small test bars were 20,000 pounds per square inch, we could depend upon having 10,000 pounds in large castings. Using a factor of safety of 10 on this would give 1,000 pounds per square inch as the safe strength of this material. The weight of a cubic inch of cast iron is approximately 0.26 pounds, so that we have for cast iron wheels:

$$V = 1.6 \sqrt{\frac{S}{W}} = 1.6 \sqrt{\frac{1000}{0.26}} = 99.2$$

per second; so that 100 feet per second may be regarded as a safe rim speed for cast-iron wheels made in one piece. This corresponds to about 1.15 miles per minute, but as such wheels are likely to contain shrinkage strains, it is not considered good practice to run them faster than a mile a minute.

If the wheel is made in halves, or sections, the efficiency of the rim joint must be taken into consideration. For belt wheels with flanged and bolted rim joints located between the arms, the joints average only one-fifth the strength of the rim, and no such joint can be designed having a strength greater than one-fourth the strength of the rim. If the rim is thick enough to allow the joint to be reinforced by steel links shrunk on, as in heavy balance wheels, one-third the strength of the rim may be secured in the joint, but this construction cannot be applied to belt wheels having thin rims.

Applying the formula to wheels made of steel casting having an ultimate strength of 60,000 pounds per square inch, or a safe strength of 6,000 pounds per square inch, and weighing 0.28 pound per cubic inch, we have:

$$V = 1.6 \sqrt{\frac{S}{W}} = 1.6 \sqrt{\frac{6000}{0.28}} = 234.3$$

per second; so that a steel casting wheel made in one piece and free from shrinkage strains could be run with perfect safety at a rim speed of 234 feet per second, corresponding to 2.66 miles per minute.

It will perhaps surprise some mechanics to learn that wheels made of wood may be run at a higher speed than those made of cast iron. Wood, however, is one of the very best materials that can be used for fly-wheel construction, and many large wheels have been constructed of this material and are giving satisfactory results. Applying the formula to hard maple having a tensile strength of 10,500 pounds per square inch, and weighing 0.0283 pound per cubic inch, we have, using a factor of safety of 20, and remembering that the strength is reduced one-half because the rim is built up of segments,

$$V = 1.6 \sqrt{\frac{S}{W}} = 1.6 \sqrt{\frac{262.5}{0.0283}} = 154.1$$

per second; so that a well-made maple wheel may be run with perfect safety at a rim speed of 154 feet per second, which corresponds to 1.75 miles per minute. Or comparing two wheels of the same diameter, one of cast iron, the other of maple, the number of revolutions per minute for the maple wheel may be 54 per cent greater than for the cast iron wheel. One hundred and fifty-four feet per second would not, however, be a safe rim speed for the wood wheel if made in halves or sections, on account of the weakness of rim joints.

Of late years wheels for large electric plants have been built up of steel plates riveted together, and wheels for special work or unusually high speed have been specially designed. It is questionable, however, whether the complicated built-up steel construction is profitable for wheels of standard steam engines as commercially built. When an engine runs fast enough to burst a well-made cast iron wheel it is doubtful whether anything would save it. The small amount of time required for the additional acceleration necessary to burst a steel wheel at that stage would be little, and when the crash did come, it would be all the more disastrous.

From the above formulas it will be seen that the stress in the rim of a wheel increases with the square of the speed, or, to put it in other words, the factor of safety on speed is always the square root of the factor of safety on strength. If the speed be tripled, for example, the stress in the rim becomes nine times as great as before; that is, with a factor of safety of nine on strength, there is a factor of safety of only three on speed. It will be understood from this that the stress increases enormously for even a slight increase in speed.

Let us consider the usual cast iron, sectional, belt wheel having flanged and bolted rim joints located between the arms. As pointed out above, such joints average a strength of only one-fifth the strength of the rim, and no joint of this kind can be designed that will have a strength greater than one-fourth the strength of the rim. If this wheel had at normal speed a factor of safety of 12 in the rim, then with joints of maximum strength the factor of safety in the joint would be only 3 on strength or 1.73 on speed. That is, an increase in speed of 73 per cent would burst the wheel. The wide gulf in this case between the apparent factor of safety of 12 on strength and the real factor of safety of 1.73 on speed is appalling. This is, however, only another warning that things are not always as they seem.

As a matter of fact, few wheels have a margin of safety of 73 per cent on speed. In the accident of the Amoskeag Mills, in which a 30-foot wheel wrecked the building, killed two girls and badly injured the assistant engineer, the evidence proved that an increase in speed of only 20 per cent caused the disaster. Many wheels in use to-day are running on a narrower margin than this. It will now be understood why racing is so frequent a cause of fly-wheel accidents. Some slight accident to the governor or valve gear of the engine occurs, and away goes the wheel, causing a costly if not fatal wreck. The stress in the rim increases so rapidly with increase of speed that sound wheels amply safe at normal speed, go to pieces without warning, and apparently without cause.

CHAPTER IV

SIZE, WEIGHT AND CAPACITY OF FLY-WHEELS FOR PUNCHES

In this chapter will be given a method of determining the size, weight and capacity of a fly-wheel to punch a given size hole through a given thickness of metal.

Effect of Relative Size of Punch and Die, and Shape of Punch

To begin with, there are a number of things which affect the effort that is required to punch a certain size hole through a given thickness of metal. In Fig. 22, P is the punch, A is the diameter of the punch, and $A + x$ is the diameter of the hole in the die. For the regular run of work, and for a $\frac{3}{4}$ -inch punch, the hole in the die would be about $\frac{1}{32}$ inch larger than the punch. If we reduce the

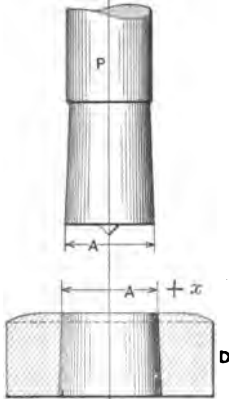

Fig. 22

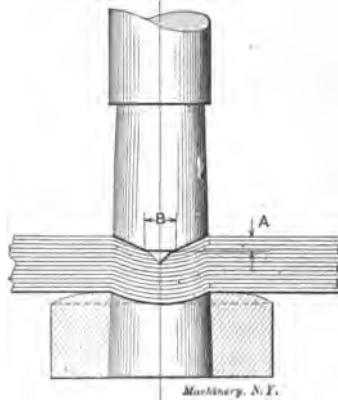

Fig. 23

size of the hole, the effort necessary to punch the hole will be greatly increased, and the life of the punch will be short, but if we increase the size of the hole, within certain limits, the effort required to punch the hole will be less, and the life of the punch will be greatly increased. The use of a large hole in the die causes a cone-shaped hole in the sheet, which is always more or less objectionable, and, therefore, one cannot get too far away from the standard proportions used by punch makers. The punching effort required will also be decreased by the use of a punch which has something of a shearing action, as shown at A , Fig. 23. The flat portion, B , enters the sheet first and probably presents no more than one-fourth the total cutting circumference of the punch. By the time the whole punch has entered into the sheet, which would represent the greatest effort required, the

metal under *B* is nearly sheared away. Through the remainder of the stroke there is a shading off of the effort required to remove the metal. The shape of the punch with reference to the diameter of the end and of the body also has some effect upon the effort.

Fig. 24 shows a regular flat punch. The sides of *S* are tapered off gradually from $\frac{3}{4}$ inch at the bottom to $1\frac{11}{16}$ inch at the top. Fig. 25 shows a similar punch with the sides parallel, but flaring off at the bottom for a distance of $\frac{3}{16}$ inch. There is little difference in the effort required in using either of these punches when both are new. But when they become worn the side pressure against the punch is considerable. It is this wearing off of the sides which causes the greatest trouble in punching. The style shown in Fig. 25 is used a

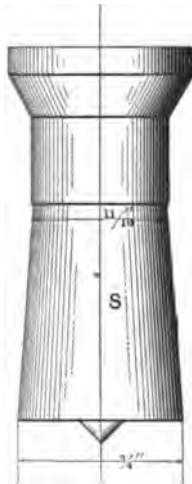
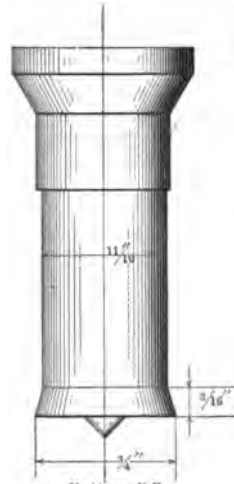

Fig. 24



Machinists, N. F.
Fig. 25

great deal in structural work, and seems to give less trouble from side friction than the punch shown in Fig. 24.

Punching Effort Proportional to Area Sheared

In calculating the size fly-wheel which will be necessary to punch a given hole, a flat punch only will be considered, and it will be assumed that the punches are kept in fairly good condition. Also, the calculations will be based upon punching wrought iron and steel, such as boiler plate, angles, tees, bars, etc.

The area sheared off in punching a 1-inch hole through a $\frac{3}{4}$ -inch plate is the circumference of a 1-inch circle, times the thickness of the sheet. The circumference of a 1-inch circle is 3.1416 inches.

Let *A* = area to be sheared = $3.1416 \times \frac{3}{4} = 2.3562$ square inches, or say, for all practical purposes, = 2.36 square inches.

For ordinary run of work, we will use a shearing resistance stress of 60,000 pounds per square inch. In working with harder or softer material, this shearing stress will have to be taken higher or lower, depending upon the shearing stress of different metals.

Let P = the push required to punch the hole, or the shearing effort,
 S = shearing stress per unit of area = 60,000 pounds per square
 inch.

We then have

$P = A \times S$, and for the case considered = $2.36 \times 60,000 = 141\,600$
 pounds = effort required to punch a 1-inch hole through $3/4$ inch plate.

In order to punch such a hole, a large amount of energy will be required for a brief period of time, as one can infer from the crank circle shown in Fig. 26, in which the punching is represented as being all done through the small portion T of the circumference. This distance represents the distance that the crank-pin passes through while removing the metal, D being the diameter of the crank-pin circle. It will be seen from the case shown that T represents about one-tenth of the crank circle. The energy required for punching would have to be given out in about one-tenth revolution of the eccentric

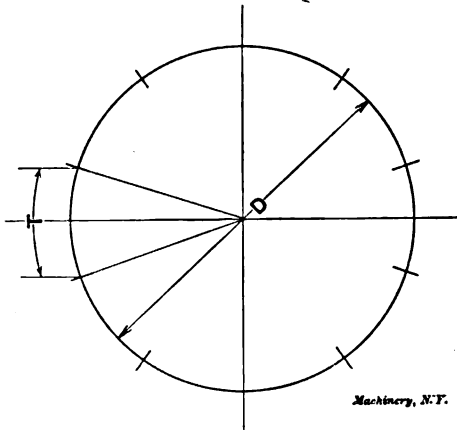

Fig. 26. Diagram of Crank-Pin Circle

shaft. During the meantime the machine can pick up energy through the other nine parts of the circumference. If the fly-wheel is properly proportioned, and if the energy applied to the machine is sufficient, the fly-wheel will pick up through these nine parts of the circumference sufficient energy to do the punching while the crank-pin is passing through the tenth part of the circumference.

Design of Fly-wheel and its Function

A good design of fly-wheel is shown in Fig. 27. The ledge L inside the fly-wheel extends from arm to arm, which makes very strong connection between the arm and rim. The outside diameter D of the fly-wheel as well as the sides are machined. The hub H should never be less than two diameters of the shaft. A good deal depends upon the strength of this hub, and as the extra metal required to increase the size of the hub is small in proportion to the size of the fly-wheel, it is good practice to make the hub, say, from $2\frac{1}{2}$ to 3 times the diameter of the shaft.

In order that the fly-wheel shall give out energy, it must slow down in speed. If the fly-wheel is not large enough, the energy required will be greater than the capacity of the fly-wheel, and the change in speed will be great. In some cases a machine might even be stopped owing to the fly-wheel not having energy enough. If a fly-wheel is properly designed it will perform its work and slow down in speed a certain percentage, but this must not be so great that the machine cannot pick up again for the next stroke. The amount that the fly-wheel can be slowed down by taking its energy away from it is a matter of experiment. For ordinary punch and shear work we can take this drop in speed to be about 20 per cent while the machine is doing the work. This would have to be regained through the belt or

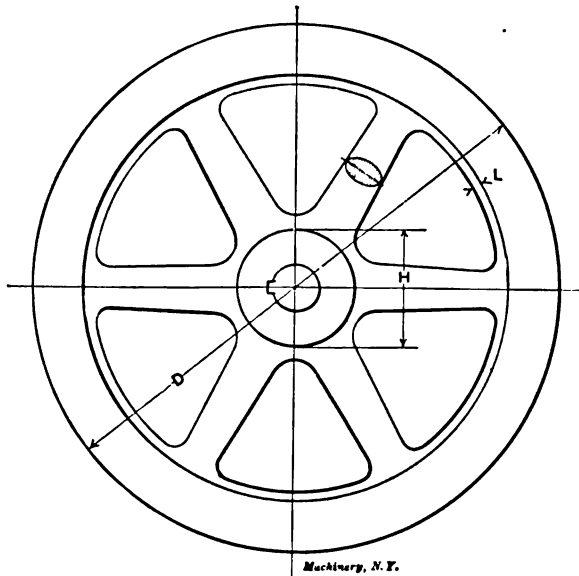

Fig. 27. Design of Fly-wheel

through the motor during the remaining portion of the stroke so that the fly-wheel would be up to speed again for punching the next hole.

There are many belted punches which are running along and doing their work satisfactorily which are not at all up to this standard of requirement. The reason for this is that these machines punch a hole only "once in a while." The drop in speed is very much greater than one-fifth, being probably one-third. If one should take such a machine with the rated capacity of 1 inch through $\frac{3}{4}$ -inch plate, and punch one hole after the other without missing a stroke, the machine would stop. In this connection, therefore, it will be noted that there is a chance for a great variation in the size of fly-wheel and the horse-power required to drive a punch. In these calculations the fly-wheel will be so proportioned as to punch its rated capacity for every stroke for continuous working.

To Calculate the Potential Energy of a Fly-wheel for a Given Reduction of Velocity

Let V = velocity of center of gravity of fly-wheel rim at normal speed before punching, in feet per second,

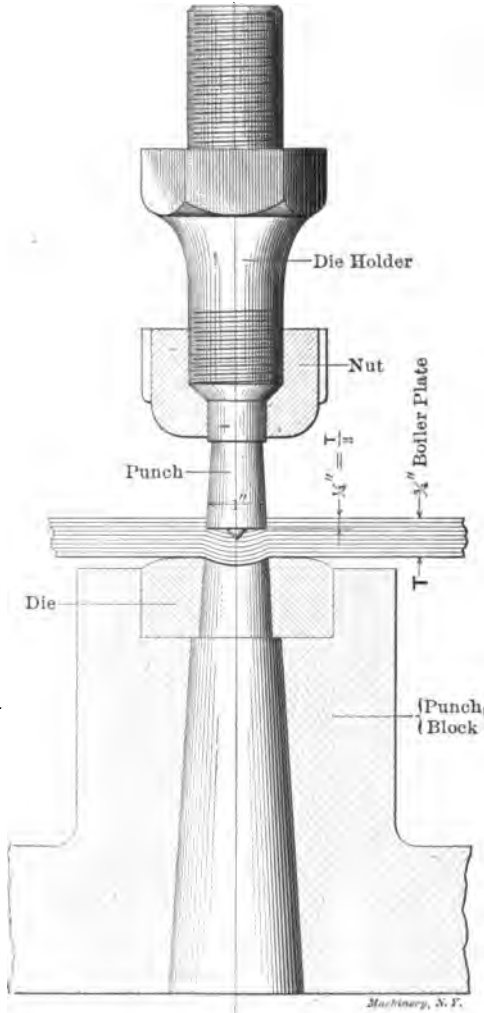

Fig. 28. Diagram Illustrating Part of Stroke Offering Maximum Resistance to Punching

- E = the energy delivered to the fly-wheel or given out by the fly-wheel for one stroke.
- W_r = weight of the rim,
- W_a = weight of the arms,
- $g = 32$ (approximately) = acceleration due to gravity,

V_1 = velocity of mean periphery of fly-wheel rim after punching, in feet per second.

$$\text{Then } E = (W_r + \frac{1}{3} W_a) \left(\frac{V^2 - V_1^2}{2g} \right) \quad (1)$$

In this expression W_a represents the weight of the arms. This is a very small percentage of the total weight of the fly-wheel, and for all purposes we can neglect this item.

Neglecting item $1/3 W_a$, we have for (1)

$$\begin{aligned} E &= W_r \frac{V^2 - V_1^2}{2g} \\ &= W_r \frac{V^2 - V_1^2}{64} \end{aligned} \quad (2)$$

To Calculate the Weight of the Fly-wheel

E also equals the energy necessary to punch a 1-inch hole through a $\frac{3}{4}$ -inch plate. Experiments show that when a punch has entered about one-third way through the sheet, see Fig. 28, the material is all sheared off, or in other words, when the punch has passed one-third way through the sheet, the hole is punched, and it then only remains to push the punching out through the die.

Let T = thickness of plate = $\frac{3}{4}$ -inch; we then have

$$\begin{aligned} E &= P \times \frac{1/3 T}{12} \\ &= \frac{P \times 1/3 \times \frac{3}{4}}{12} \\ &= \frac{141,600}{4 \times 12} \end{aligned}$$

= 2,950 foot-pounds = energy required per stroke.

By transposing equation (2), we have

$$W_r = \frac{E \times 64}{V^2 - V_1^2} \quad (3)$$

In order to determine the size of the fly-wheel, we must know the speed of the fly-wheel, and we must assume a diameter which in our judgment would be approximately correct. We will take for the present case a single-ended punch, as shown in Fig. 29, with bottom drive, with tight and loose pulleys and with a single fly-wheel F running at a normal speed of 175 R. P. M. before punching and falling off 20 per cent during the actual punching operation. This machine should take a fly-wheel about 36 inches outside diameter, or say about 30 inches diameter at center of gravity of rim. The velocity in feet per second would be

$$\begin{aligned}
 V &= \frac{\text{dia.} \times \pi}{12} \times \frac{175}{60} \\
 &= 23 \text{ feet. Substituting in (3) we get} \\
 W_r &= \frac{E \times 64}{V^2 - V_1^2} = \frac{2950 \times 64}{23^2 - 18.4^2} \\
 &= 992 \text{ pounds, weight of fly-wheel.}
 \end{aligned}$$

This fly-wheel would be made of cast iron and the section of the rim would be obtained thus:

Let B = the face of the fly-wheel (see Fig. 30) = $6\frac{3}{4}$ inches,
 H = the average thickness of the rim. We then have

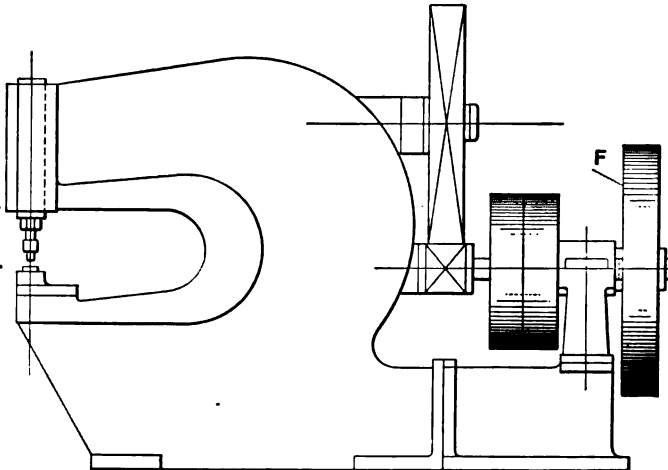

Fig. 29. Single-ended Punch

Machinery, N.F.

$W_r = 6\frac{3}{4} \times H \times 30 \times \pi \times 0.26$, and transposing

$$\begin{aligned}
 H &= \frac{W_r}{6\frac{3}{4} \times 30 \times \pi \times 0.26} \\
 &= \frac{992}{6\frac{3}{4} \times 30 \times \pi \times 0.26} \\
 &= 6 \text{ inches depth of rim.}
 \end{aligned}$$

The fly-wheel, therefore, should be 36 inches outside diameter with a rim $6\frac{3}{4}$ inches face by 6 inches thick.

Effect of Frame Elasticity in Reducing Efficiency

There is another thing which should be mentioned in connection with the size of a fly-wheel which would be required to do a certain amount of work. If the machine is not stiff in the frame or shafting, a large amount of energy will disappear, and there is apparently nothing to show for it. This can best be explained by referring to Fig. 31, which shows a double-ended punch. If the shaft S is small

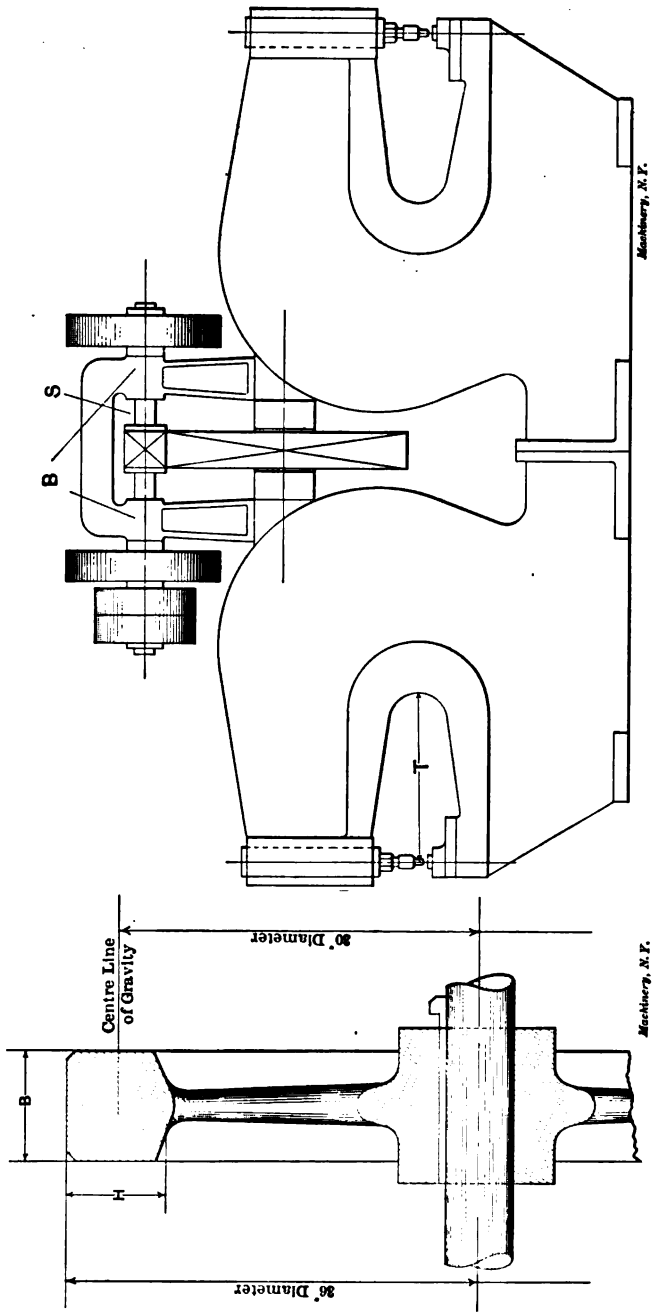

Fig. 81. Double-ended Punch

Fig. 80

Machinery, N. Y.

Machinery, N. Y.

in diameter, or if the distance between the bearings *B* and *B* is great, this shaft will spring, and the result or the effect of the fly-wheel is "deadened." Also, if the eccentric shaft is very long and is small in diameter, it will have the same effect, hence the great importance of a solid machine for punching. It is remarkable what capacity the upright punching press has, but this is largely due to the very solid construction. The metal in the upright is in direct tension, therefore the spring or stretch is small. With a regular punching machine,

TABLE III. DIMENSIONS OF FLY-WHEELS FOR PUNCHES

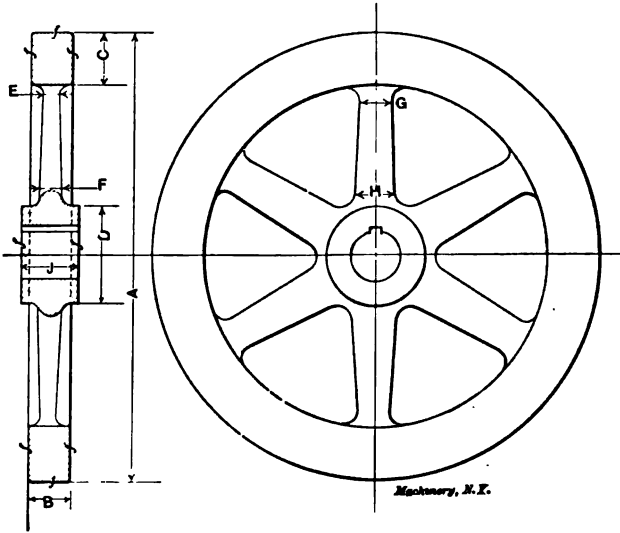

A	B	C	D	E	F	G	H	J	Max. R.P.M.
24	3	3½	6	1½	1½	2½	3½	3½	955
30	3½	4	7	1½	1½	3	3½	4	796
36	4	4½	8	1½	1½	3½	4½	4½	687
42	4½	4½	9	1½	2	3½	4½	5	557
48	4½	5	10	1½	2	3½	4½	5½	478
54	4½	5½	11	2	2½	4	5	6	480
60	5	6	12	2½	2½	4½	5½	6½	382
72	5½	7	13	2½	2½	5	6½	7	318
84	6	8	14	3	3½	5½	7½	8	278
96	7	9	15	3½	4	6	9	9	239
108	8	10	16½	3½	4½	6½	10½	10	212
120	9	11	18	4	5	7½	12	12	191

however, there are a number of chances for spring, and each cuts down the fly-wheel effect.

With a short throat punch there is not much spring in the frame, but with a deep throat punch the spring is considerable in amount. A spring of 1/8 to 3/16 inch at the dies is a very common thing. A deep throat machine will punch far beyond its rated capacity if the tie-

rods are placed close up to the head. This stiffens the machine and concentrates the work of the fly-wheel on the metal being punched. A short throat punch is usually rated higher in capacity than a deep throat punch of the same pattern. In figuring the size fly-wheel, therefore, it should be made large enough to do the work of a short throat punch.

When a double-end punch is required, as in Fig. 31, one or two fly-wheels may be used. Frequently, on account of the limited space, two fly-wheels must be used. This wheel or wheels, as the case may be, should be calculated to do the continuous work of both ends of the machine. It will be noted in equation (2) that E varies with the square of the velocity of the fly-wheel; we can take advantage of this fact sometimes, where a punch has a fly-wheel that is somewhat too light. The machine can be speeded up, which will give the fly-wheel more energy, and in this way will punch up to the capacity of the machine.

Limitations of Fly-wheel Size and Speed

In practise there are a number of things which limit the diameter and speed of a fly-wheel, and in such cases the weight must be gotten by either increasing the face and thickness of the rim or else putting on two fly-wheels. Table III, on the previous page, gives the dimensions of fly-wheels. The last column gives the maximum R. P. M. at which a cast iron fly-wheel should be run. There are cases where very high speeds of fly-wheels cannot be avoided, but as far as possible the tendency is to use a heavy fly-wheel at moderate speed and one or two runs of heavy gears.

If a punch is fitted with a proper size fly-wheel, and the motor or pulleys are too small when running on continuous work, the machine will slow down and stop. In the case of a belted machine, the belt will break or slide off the pulley, and in the case of motor drive, the motor probably will be so overloaded as to cause it to burn out after running awhile.

Calculation of Horse-Power Required for a Punch, and Width of Belt

We can determine the horse-power necessary to run a punch in the following manner: Take the case of a 1-inch diameter by ¼-inch punch, running 30 strokes per minute; we have

$$E = 2,950 \text{ foot-pounds energy per stroke,}$$

Let $H. P.$ = horse-power,

N = number of strokes per minute.

We then have

$$H. P. = \frac{E \times N}{33,000} \tag{4}$$

$$= \frac{2,950 \times 30}{33,000}$$

= 2.7 H. P. for a single machine, or $2 \times 2.7 = 5.4$ H. P. for a double machine with both sides running continuously.

A machine of this size would most likely be run with a single belt which would be considered to exert a pull of 40 pounds per inch width of belt. We will assume a certain diameter for the pulley, and figure the face to suit the required horse-power.

Let D = the diameter of the pulley in inches = 20 inches,

x = face in inches,

n = 175 R. P. M. of pulley,

$$H.P. = \frac{D \times \pi}{12} \times \frac{40 \times x \times n}{33,000}, \text{ and transposing we get}$$

$$x = \frac{H.P. \times 12 \times 33,000}{D \times \pi \times 40 \times n} \text{ for single machine} \quad (5)$$

$$= \frac{2.7 \times 12 \times 33,000}{20 \times \pi \times 40 \times 175} = 2.45 \text{ inches belt width,}$$

= say, 3 inches belt face of pulley for single punch.

For a double punch we would require twice the power, or assuming 30 inches diameter for the pulley and substituting in (5), we get

$$x = \frac{H.P. \times 12 \times 33,000}{D \times \pi \times 40 \times n}$$

$$= \frac{5.4 \times 12 \times 33,000}{30 \times \pi \times 40 \times 175} = 3.25 \text{ inches belt width.}$$

= say $3\frac{1}{4}$ inches belt face of pulley for double machine.

If these machines were to be motor driven, the single machine would require at least a 3-horse-power motor and the double machine from 5 to $7\frac{1}{2}$ horse-power motor. A 5-horse-power motor would in all probability be all right, as a double machine would hardly be run so as to use every stroke. It is always best, however, to have a motor that is a little larger than is required, as punching is very severe work on the motor, especially when the motor is geared to the fly-wheel shaft through cut spur gears. The variation in speed jars the motor, and this tells on the windings, etc. The variation of the speed in the fly-wheel has less effect on the motor if it is belted, or if it is connected to the machine through a slip gear or a friction clutch.

CHAPTER V

SIMPLIFIED METHODS FOR FLY-WHEEL CALCULATIONS

In the previous chapter the customary methods and formulas have been given relating to the design of fly-wheels and the size of motor required for giving out a certain amount of energy per stroke of the machine under consideration. In this chapter a method of calculation will be given, whereby the work of finding the desired results may be considerably shortened.

In shears of large size cutting short pieces, where the maximum effort may be required almost continuously, it is of great importance that motor and fly-wheel be of sufficient capacity to perform their work properly. Since the amount of energy to be given out by the fly-wheel depends upon the size of the motor, this should always be determined first. Let

E = total energy required per stroke,

E_1 = energy given up by motor during cut,

E_2 = energy given up by fly-wheel,

T = time in seconds per stroke,

T_1 = time in seconds in which E_1 is given up,

T_2 = time in seconds in which E_2 is restored to fly-wheel,

V_1 = initial velocity of fly-wheel in feet per second,

V_2 = velocity after cut in feet per second,

R_1 = initial revolutions per minute of fly-wheel,

R_2 = revolutions per minute after cut,

R_n = revolutions per minute after n cuts,

W = weight of fly-wheel rim in pounds,

D = mean diameter of fly-wheel rim in feet,

H_1 = horse-power required to cut every stroke,

H_2 = horse-power actually used,

a = width of fly-wheel rim,

b = depth of fly-wheel rim,

$g = 32.16$,

n = number of cuts shear will make for a total given reduction in speed.

In the previous chapter this formula for the horse-power required was given:

$$H. P. = H_1 = \frac{EN}{33,000},$$

and since $N = \frac{60}{T}$ we have

$$H_1 = \frac{E}{550T} \quad (1)$$

$$H_1 = \frac{E_1}{550 T_1}$$

$$E_1 = 550 T_1 H_1 = \frac{550 E T_1}{550 T} = \frac{E T_1}{T}$$

$$E_2 = E - \frac{E T_1}{T} = E \left(1 - \frac{T_1}{T} \right) \quad (2)$$

Having now the energy that must be given out by the fly-wheel, we can proceed as follows:

We know that $E_2 = \frac{W}{2g} (V_1^2 - V_2^2)$ and that

$$V_1^2 = \left(\frac{D \times \pi \times R_1}{60} \right)^2 = 0.00274 D^2 R_1^2$$

$$V_2^2 = \left(\frac{D \times \pi \times R_2}{60} \right)^2 = 0.00274 D^2 R_2^2$$

$$V_1^2 - V_2^2 = 0.00274 D^2 (R_1^2 - R_2^2)$$

$$E_2 = \frac{W}{64.82} \times 0.00274 D^2 (R_1^2 - R_2^2)$$

$$E_2 = 0.0000426 W D^2 (R_1^2 - R_2^2) \quad (3)$$

$$W = \frac{E_2}{0.0000426 D^2 (R_1^2 - R_2^2)} \quad (4)$$

Making $0.0000426 (R_1^2 - R_2^2) = C R_1^2$ we have

$$E_2 = C W D^2 R_1^2 \quad (5)$$

$$W = \frac{E_2}{C D^2 R_1^2} \quad (6)$$

In cast iron fly-wheels it is usual not to exceed a speed which represents a fiber stress of more than 1,000 pounds per square inch of rim cross section. The stress in pounds due to centrifugal force equals $0.0972 V_1^2$ for cast iron, and for fly-wheels having a maximum stress of 1,000 pounds per square inch, we can develop the following formulas:

$$0.0972 V_1^2 = 1,000; V_1 = 101.5.$$

But $V_1 = \frac{D \pi R_1}{60}$, therefore we have

$$101.5 = \frac{D \pi R_1}{60}$$

$$R_1 = \frac{101.5 \times 60}{D \pi} = \frac{1,940}{D} \quad (7)$$

$$D = \frac{1,940}{R_1} \quad (8)$$

Squaring (7) we have $R_1^2 = \frac{1,940^2}{D^2}$

Substituting this in (6) we have

$$W = \frac{E_2}{C D^2 \frac{1,940^2}{D^2}} = \frac{E_2}{1,940^2 C}$$

Making $1,940^2 C = C_1$, and $\frac{1}{C_1} = C_2$ we have

$$W = \frac{E_2}{C_1} = C_2 E_2 \quad (9)$$

The following are the values of C , C_1 , and C_2 for different reductions in speed:

Per cent. Reduction.	C	C_1	C_2
2½	0.00000213	8.00	0.1250
5	0.00000426	16.00	0.0625
7½	0.00000617	23.20	0.0432
10	0.00000810	30.45	0.0328
12½	0.00001000	37.60	0.0266
15	0.00001180	44.50	0.0225
20	0.00001535	57.70	0.0173

Size of Rim

Let us assume that the depth of rim equals 1.22 times the width. We have then these formulas for size of rim:

$$a = \sqrt{\frac{W}{12 D}} \quad (10)$$

$$b = 1.22 a \quad (11)$$

These two formulas can be changed to suit any required ratio of depth to width of rim.

Let y = required ratio,

$$a = \sqrt{\frac{1.22 W}{12 D y}} \quad (12)$$

$$b = ya \quad (13)$$

Effect of Changing Size of Motor

Let us now suppose that we do not wish to use a motor large enough to cut continuously, and desire to find how many cuts the machine would make continuously without drifting down more than a certain percentage of the original speed. Transposing (3) we have

$$R_1^2 - R_2^2 = \frac{E_2}{0.0000426 W D^2}$$

$$\text{Let } \frac{E_2}{0.0000426 W D^2} = K.$$

$K = R_1^2 - R_2^2$, and

$$R_2 = \sqrt{R_1^2 - K}$$

$$R_2 = \sqrt{R_1^2 - nK + (n-1)K \frac{H_2}{H_1}} \quad (14)$$

After several reductions we have

$$n = \frac{\frac{H_1 (R_1^2 - R_2^2)}{K} - H_2}{H_1 - H_2}$$

and since $K = R_1^2 - R_2^2$ we have

$$n = \frac{\frac{H_1 (R_1^2 - R_2^2)}{R_1^2 - R_2^2} - H_1}{H_1 - H_2} \quad (15)$$

The time now required to bring the fly-wheel up to full speed again after n cuts will be

$$T_2 = \frac{E_2}{550 H_2} \quad (16)$$

Examples

We will now work out some examples illustrating the use of these formulas.

Example 1.—A hot slab shear is required to cut a slab 4 × 15 inches which, at a shearing stress of 6,000 pounds per square inch, gives a pressure between the knives of 360,000 pounds. The total energy re-

quired for the cut will then be $360,000 \times \frac{4}{12} = 120,000$ foot-pounds. The shear is to make 20 strokes per minute, and with a six-inch stroke the actual cutting time is 0.75 seconds, and the balance of the stroke is 2.25 seconds.

The fly-wheel is to have a mean diameter of 6 feet 6 inches and is to run at a speed of 200 R. P. M.; the reduction in speed to be 10 per cent per stroke when cutting.

$$H_1 = \frac{120,000}{8 \times 550} = 72.7 \text{ horse-power.}$$

$$E_2 = 120,000 \times \left(1 - \frac{0.75}{8}\right) = 90,000 \text{ foot-pounds.}$$

$$W = \frac{90,000}{0.0000081 \times 6.5^2 \times 200^2} = 6570 \text{ pounds.}$$

Assuming a ratio of 1.22 between depth and width of rim,

$$a = \sqrt{\frac{6,570}{12 \times 6.5}} = 9.18 \text{ inches,}$$

$$b = 1.22 \times 9.18 = 11.2 \text{ inches,}$$

or size of rim, say, 9 × 11½ inches.

Example 2.—Suppose we wish to make the fly-wheel in Example 1 with a stress of 1,000 pounds, due to centrifugal force, per square inch of rim section.

$$C_2 \text{ for 10 per cent} = 0.0328,$$

$$W = 0.0328 \times 90,000 = 2,950 \text{ pounds,}$$

$$R_1 = \frac{1940}{D} \quad \text{If } D = 6 \text{ ft., } R_1 = \frac{1910}{6} = 323 \text{ R. P. M.}$$

$$a = \sqrt{\frac{2950}{12 \times 6}} = 6.4 \text{ inches}$$

$$b = 1.22 \times 6.4 = 7.8 \text{ inches,}$$

or size of rim, say, $6\frac{1}{4} \times 8$ inches.

Example 3.—Let us now suppose that in Example 1 we wish to use a 50 H. P. motor, and wish to find how many cuts the shear will make continuously without drifting down more than 20 per cent in speed? And what time must be allowed for the motor to restore the fly-wheel to its original speed?

$$R_1^2 - R_2^2 = 200^2 - 160^2 = 14400$$

$$R_1^2 - R_2^2 = 200^2 - 180^2 = 7600$$

$$\frac{72.7 \times 14400}{7600} - 50$$

$$n = \frac{\quad}{72.7 - 50} = 8.86 \text{ cuts}$$

Allowing the shear to make 4 cuts we have

$$R_2 = \sqrt{200^2 - 4 \times 7600 + 8 \times 7600 \times \frac{50}{72.7}} = 159 \text{ R. P. M.}$$

$$E_2 = 0.0000426 \times 6570 \times 6.5^2 \times (200^2 - 159^2) = 175,000 \text{ foot-pounds, about.}$$

$$T_2 = \frac{175000}{550 \times 50} = 6.4 \text{ seconds.}$$

Example 4.—Let us now suppose that in Example 2 we wish to use a 50 H. P. motor under the same conditions as in Example 3.

$$R_1^2 - R_2^2 = 323^2 - 258^2 = 37750$$

$$R_1^2 - R_2^2 = 323^2 - 291^2 = 19650$$

$$\frac{72.7 \times 37750}{19650} - 50$$

$$n = \frac{\quad}{72.7 - 50} = 4 \text{ cuts, nearly.}$$

$$E_2 = 0.0000426 \times 2950 \times 6^2 \times (323^2 - 258^2) = 170,000 \text{ foot-pounds, about.}$$

$$T_2 = \frac{170,000}{550 \times 50} = 6.2 \text{ seconds.}$$

These examples show the possibilities of the formulas as time-savers for the designer, by reducing the calculations to the smallest possible number, and at the same time reducing the possibility of error.

CHAPTER VI

FLY-WHEELS FOR MOTOR-DRIVEN PLANERS

The question of motor drive for high-speed planing machines brings forward many interesting problems, among which the ascertaining of the correct dimensions for the flywheel is not the least. The primary function of a fly-wheel is here not so much the preservation of a constant speed as the relieving of the motor from excessive shock at the instant of reversal.

A shunt-wound motor tends to keep the same speed at all loads, but must necessarily slow down for a moment, however large the fly-wheel at the instant of reversal, thus tending to spark. Of course, the larger the motor, the greater the store of energy in the armature, consequently the smaller the drop in speed and less tendency to sparking. A compound-wound motor, on the other hand, will drop slightly in speed under heavy loads, the percentage of drop, of course, depending upon the amount of compounding. It is this property of the compound motor which enables the fly-wheel to perform its work satisfactorily. A correctly designed fly-wheel will, at the moment of reversal, keep up the speed of the motor slightly higher than that corresponding to the load on the motor at that instant, thus eliminating all possibility of sparking.

Now the determining of the dimensions of the fly-wheel before the machine is made, to fulfill these conditions, necessitates close scrutiny of the engineering press, so as to be continually cognizant of tests taken at different times on high-speed planing machines. A better method, where practicable, is to test the machine before deciding upon either the motor or the fly-wheel.

A machine recently tested under the latter condition gave the following: Average horse-power, cutting, 19; average horse-power, backing, 11. At the instant of reversal to backing stroke the ammeter needle jumped to 190 on a 220-volt circuit, showing maximum horse-power to be about 55, and the time taken up from the table-striking the dog to the attainment of maximum backing speed was 3 seconds. It was decided to drive this machine by a 30 B. H. P. motor at 500 revolutions per minute, compounded so as to give a maximum variation of about 12 or 14 per cent. Allowing a 40 per cent momentary overload on the motor would bring the maximum horse-power allowable on reversal to 42, and the additional 13 horse-power would have to be supplied by the fly-wheel. The dimensions of the wheel were obtained in the following manner:

As energy in a moving body varies directly as V^2 , where V = velocity in feet per second, it is clear that the best place for the fly-wheel is upon the shaft having the greatest number of revolutions per minute, which, of course, is the motor shaft. From the figures given,

it will be seen that the wheel must be capable of parting with sufficient energy to develop 13 horse-power during the time of reversal, viz., 3 seconds, and its drop in speed must not exceed 10 per cent, so as to keep the actual variation slightly below that allowed by the motor.

$$\text{Energy to be given out by the fly-wheel} = \frac{13 \times 33,000 \times 3}{60}$$

Now assume M to be the store of energy in foot-pounds in this fly-wheel when it makes one revolution per minute; then, as the energy varies as V^2 , and V varies as the revolutions per minute, the store of energy in the wheel when making 500 revolutions per minute = $M \times 500^2$.

As the drop of speed of the wheel = 10 per cent of speed of wheel, the speed of the wheel at the end of three seconds = 500 — 10 per cent of 500 = 450 revolutions per minute, and the store of energy then in the wheel = $M \times 450^2$.

Thus the energy given up by the wheel in being reduced from 500 to 450 revolutions per minute = $M (500^2 - 450^2)$.

$$\text{But the energy given up must} = \frac{13 \times 33,000 \times 3}{60}, \text{ as already shown;}$$

$$\text{therefore } M (500^2 - 450^2) = \frac{13 \times 33,000 \times 3}{60}$$

$$M = \frac{13 \times 33,000 \times 3}{60 (500^2 - 450^2)}$$

$$= \frac{13 \times 33,000 \times 3}{60 \times 47,500}$$

$$M = 0.45 \text{ foot-pounds.}$$

Therefore, the store of energy in the fly-wheel when making 1 revolution per minute = 0.45 foot-pounds.

The limit of peripheral speed of plate fly-wheels generally allowed in machine tool practice is about 7,000 feet per minute, which quantity will enable us to find the outside diameter of the wheel thus:

$$\frac{7,000}{3.1416 \times 500} = 4.4 \text{ feet.}$$

$$\text{As the energy in a revolving wheel} = \frac{W V^2}{2g}, \text{ where } V = \text{velocity in}$$

$$\text{feet per second at center of area of rim, } \frac{W V^2}{2g} \text{ must equal 0.45 when}$$

$$\text{the wheel makes 1 revolution per minute. Therefore } \frac{W V^2}{2 \times 32.2} = 0.45.$$

Velocity of wheel in feet per second when wheel makes 1 revolution

per minute = $\frac{4 \times 3.1416}{60}$; the diameter of the wheel to center of area,

it will be seen, is taken as 4 feet, 4.4 feet being the outside diameter; thus

$$\frac{W \times 4 \times 4 \times 3.1416 \times 3.1416}{2 \times 32.2 \times 60 \times 60} = 0.45.$$

$$W = \frac{0.45 \times 2 \times 32.2 \times 60 \times 60}{4 \times 4 \times 3.1416 \times 3.1416}; W = 660 \text{ pounds.}$$

Thus, knowing the outside diameter and the weight of the wheel, the other dimensions are very easily ascertained.

Cutting Speeds; Feeds; Indexing; Use of Formulas and Tables of Sines and Tangents.

No. 19. USE OF FORMULAS IN MECHANICS.—Mathematical Signs and Formulas; Strength of Materials; Graphical Methods; Levers; Center of Gravity.

No. 20. SPIRAL GEARING.—Calculating Spiral Gears; Rules, Formulas, and Diagrams for Designing Spiral Gears; Efficiency of Spiral Gearing, etc.

No. 21. MEASURING TOOLS.—History and Development of Standard Measurements; Special Callipers; Compasses; Micrometer Tools; Protractors, etc.

No. 22. CALCULATION OF ELEMENTS OF MACHINE DESIGN.—Factor of Safety; Strength of Bolts; Riveted Joints; Keys and Keyways; Toggle-joints.

No. 23. THEORY OF CRANE DESIGN.—Jib Cranes; Calculation of Shaft, Gears, and Bearings; Force Required to Move Crane Trolleys, etc.

No. 24. EXAMPLES OF CALCULATING DESIGNS.—Charts in Designing; Punch and Riveter Frames; Shear Frames; Billet and Bar Passes; etc.

No. 25. DEEP HOLE DRILLING.—Methods of Drilling; Construction of Drills.

No. 26. MODERN PUNCH AND DIE CONSTRUCTION.—Construction and Use of Sub-press Dies; Modern Blanking Die Construction; Drawing and Forming Dies.

No. 27. LOCOMOTIVE DESIGN, Part I.—Boilers, Cylinders, Pipes and Pistons.

No. 28. LOCOMOTIVE DESIGN, Part II.—Stephenson Valve Motion; Theory, Calculation and Design of Valve Motion; The Walschaerts Valve Motion.

No. 29. LOCOMOTIVE DESIGN, Part III.—Smokebox; Exhaust Pipe; Frames; Cross-heads; Guide Bars; Connecting-rods; Crank-pins; Axles; Driving-wheels.

No. 30. LOCOMOTIVE DESIGN, Part IV.—Springs, Trucks, Cab and Tender.

No. 31. SCREW THREAD TOOLS AND GAGES.—Screw Thread Systems; Thread Tools; Making Thread Gages; Measuring Screw Thread Diameters.

No. 32. SCREW THREAD CUTTING.—Change Gears; Thread Tools; Kinks.

No. 33. SYSTEMS AND PRACTISE OF THE DRAFTING-ROOM.—Standard Drafting-room Methods; Suggestions in Making Drawings; Drafting-room Kinks.

No. 34. CARE AND REPAIR OF DYNAMOS AND MOTORS.

No. 35. TABLES AND FORMULAS FOR SHOP AND DRAFTING-ROOM.—The Use of Formulas; Solution of Triangles; Strength of Materials; Gearing; Screw Threads; Tap Drills; Drill Sizes; Tapers; Keys; Jig Bushings, etc.

No. 36. IRON AND STEEL.—Principles of Manufacture and Treatment.

No. 37. BEVEL GEARING.—Rules and Formulas; Examples of Calculation; Tooth Outlines; Strength and Durability; Design; Methods of Cutting Teeth.

No. 38. GRINDING AND LAPPING.—Grinding and Grinding Machines; Disk Grinders; Bursting of Emery Wheels; Kinks; Lapping Flat Work and Gages.

No. 39. FANS, VENTILATION AND HEATING.—Fans; Heaters; Shop Heating.

No. 40. FLY-WHEELS.—Their Purpose, Calculation and Design.

No. 41. JIGS AND FIXTURES, Part I.—Principles of Jig and Fixture Design; Drill and Boring Jig Bushings; Locating Points; Clamping Devices.

No. 42. JIGS AND FIXTURES, Part II.—Open and Closed Drill Jigs.

No. 43. JIGS AND FIXTURES, Part III.—Principles of Boring Jig Design; Boring, Reaming and Facing Tools; Milling and Planing Fixtures.

No. 44. MACHINE BLACKSMITHING.—Systems, Tools and Machines used.

No. 45. DROP FORGING.—Lay-out of Plant; Methods of Drop Forging; Dies.

No. 46. HARDENING AND TEMPERING.—Hardening Plants; Treating High-Speed Steel; Hardening Gages; Case-hardening; Hardening Kinks.

No. 47. ELECTRIC OVER-HEAD CRANES.—Design and Calculation.

No. 48. FILES AND FILING.—Types of Files; Using and Making Files.

The Industrial Press, Publishers of MACHINERY

49-55 Lafayette Street

**Subway Station,
Worth Street**

New York City, U.S.A.

