

# MACHINERY'S REFERENCE SERIES MACHINERY'S

EACH NUMBER IS ONE UNIT IN A COMPLETE LIBRARY OF MACHINE DESIGN AND SHOP PRACTICE REVISED AND REPUBLISHED FROM MACHINERY

No. 36

## IRON AND STEEL

PRINCIPLES OF MANUFACTURE, STRUCTURE, COMPOSITION  
AND TREATMENT

### CONTENTS

|  |    |
|--|----|
| Principles of Iron and Steel Manufacture                               | 3  |
| Steel Castings   | 10 |
| Steel Hardening Metals   | 13 |
| Development and Use of High-Speed Steel                                | 19 |
| Hardening Steel, by E. R. MARKHAM                                      | 30 |
| Case-Hardening   | 35 |
| The Brinell Method of Testing the Hardness of Metals,<br>by ERIK OBERG | 41 |

## MACHINERY'S REFERENCE SERIES.

This treatise is one unit in a comprehensive Series of Reference books originated by MACHINERY and announced in the publication for the first time on January 1st, 1908. The plan comprehends an indefinite number of compact units, each covering one subject thoroughly in the practical manner characteristic of MACHINERY, and sold singly, or in complete sets, as may be desired. The whole Series will comprise a complete working library of mechanical literature in which the Mechanical Engineer, the Master Mechanic, the Designer, the Machinist and Toolmaker will find the special information he wishes to secure, selected, carefully revised and condensed for him. It is the aim of this Reference Series to present the very best that has been published in MACHINERY on machine design, construction and operation during the past fourteen years, amplified wherever necessary, classified and carefully edited by MACHINERY'S staff.

Each book measures 6 x 9 inches, standard size, and contains from 32 to 56 pages, depending upon the amount of space required to adequately cover its subject. The books are first-class in every respect—printed from new type and engravings, on good paper, with wide margins to allow for binding the books in sets, should this be desired. The price of each book is only 25 cents, and it is possible to secure them on even more favorable terms under special offers issued by MACHINERY'S Circulation Department, and sent to any one on request.

The success of this Reference Series was instantaneous, and copies of the books that have been published so far are now widely distributed in machine shops and metal-working plants everywhere. The first editions of some of the treatises were exhausted in a few weeks, and second editions of 10,000 copies have been printed.

### CONTENTS OF REFERENCE BOOKS.

No. 1. WORM GEARING.—Calculating Dimensions for Worm Gearing; Hobs for Worm-Gears; Location of Pitch Circle; Self-Locking Worm Gearing; etc.

No. 2. DRAFTING-ROOM PRACTICE.—Drafting-Room System; Tracing, Lettering and Mounting; Card Index Systems.

No. 3. DRILL JIGS.—Elementary Principles of Drill Jigs; Drilling Jig Plates; Examples of Drill Jigs; Jig Bushings; Using Jigs to Best Advantage.

No. 4. MILLING FIXTURES.—Elementary Principles of Milling Fixtures; Collection of Examples of Milling Fixture Design, from practice.

No. 5. FIRST PRINCIPLES OF THEORETICAL MECHANICS.—Introduces theoretical mechanics in a manner suited to the practical man.

No. 6. PUNCH AND DIE WORK.—Principles of Punch and Die Work; Suggestions for the Making and Use of Dies; Examples of Die and Punch Design.

No. 7. LATHE AND PLANER TOOLS.—Cutting Tools for Planer and Lathe; Boring Tools; Shape of Standard Shop Tools; Forming Tools.

No. 8. WORKING DRAWINGS AND DRAFTING-ROOM KINKS.—Principles of Making Working Drawings; Drafting Tools; Draftsmen's Kinks.

No. 9. DESIGNING AND CUTTING CAMS.—Drafting of Cams; Cam Curves; Cam Design and Cam Cutting; Suggestions in Cam Making.

See inside back cover for additional titles.

# MACHINERY'S REFERENCE SERIES

EACH NUMBER IS ONE UNIT IN A COMPLETE  
LIBRARY OF MACHINE DESIGN AND SHOP  
PRACTICE REVISED AND REPUB-  
LISHED FROM MACHINERY

NUMBER 36

## IRON AND STEEL

PRINCIPLES OF MANUFACTURE, STRUCTURE, COMPOSITION  
AND TREATMENT

### CONTENTS

|  |           |    |
|--|-----------|----|
| Principles of Iron and Steel Manufacture                               | - - -     | 3  |
| Steel Castings   | - - - - - | 10 |
| Steel Hardening Metals   | - - - - - | 13 |
| Development and Use of High-Speed Steel                                | - -       | 19 |
| Hardening Steel, by E. R. MARKHAM                                      | - - - -   | 30 |
| Case-Hardening   | - - - - - | 35 |
| The Brinell Method of Testing the Hardness of Metals,<br>by ERIK OBERG | - - - - - | 41 |



## CHAPTER I.

### PRINCIPLES OF IRON AND STEEL MANUFACTURE.

The principles of iron and steel manufacture as outlined in the present chapter were originally given in an article by Mr. George Schuhmann in *The Pilot*, and republished in the August, 1907, issue of *MACHINERY*.

Commercial iron and steel are metallic mixtures, the chief ingredient of which is the element "iron," that is, pure iron, of which they contain from 93 per cent to over 99 per cent. The difference between iron and steel is principally due to the composition and proportion of the remaining ingredients.

Iron ore is an oxide of iron (iron rust) containing from 35 per cent to 65 per cent of iron; the balance is oxygen, phosphorus, sulphur, silica (sand), and other impurities. The ore is charged in a blast furnace, mixed with limestone as a flux, and melted down with either charcoal, coke, or anthracite coal as fuel; the resulting metal is what is commercially known as pig iron, containing about 93 per cent of pure iron, 3 to 5 per cent of carbon (pure coal), some silicon, phosphorus, sulphur, etc. This pig iron is used in foundries for the manufacture of iron castings, by simply remelting it in a cupola without materially changing its chemical composition; the only result is a closer grain and somewhat increased strength.

#### The Puddling Process.

In the manufacture of wrought iron the pig iron is remelted in so-called puddling furnaces, by charging about  $\frac{1}{2}$  ton in a furnace; while in a molten state, the iron is stirred up with large iron hooks by the puddler and his helper, and kept boiling, so as to expose every part of the iron bath to the action of the flame in order to burn out the carbon. The other impurities will separate from the iron, forming the puddle cinder.

The purer the iron the higher is its melting point. Pig iron melts at about 2,100 degrees F., steel at about 2,500 degrees, and wrought iron at about 2,800 degrees. The temperature in the puddling furnace is high enough to melt pig iron, but not high enough to keep wrought iron in a liquid state; therefore, as soon as the small particles of iron become purified they partly congeal (come to nature), forming a spongy mass in which small globules of iron are in a semi-plastic state, feebly cohering with fluid cinder filling the cavities between them. This sponge is divided by the puddler into lumps of about 200 pounds each; these lumps or balls are taken to a steam hammer or squeezer, where they are hammered or squeezed into elongated blocks (blooms), and while still hot, rolled out between the puddle rolls into bars 3 to 6 inches wide,  $\frac{3}{4}$  inch thick, and 15 to 30 feet long. These

bars are called puddle bars or muck bars, and, owing to the large amount of cinder still contained therein, they have rather rough surfaces. The muck bars are cut up into pieces from 2 to 4 inches long, and piled on top of each other in so-called "piles" varying from 100 to 2,000 pounds, according to the size product desired. These piles are heated in heating furnaces, and when white hot, are taken to the rolls to be welded together and rolled out into merchant iron in the shape of either sheets, plates, bars, or structural shapes, as desired. When cold, this material is sheared and straightened, and is then ready for the market.

After leaving the puddling furnace, wrought iron does not undergo any material change in its chemical composition, and the only physical change is an expulsion of a large portion of the cinder; the small cinder-coated globules of iron are welded together and the subsequent rolling back and forth will elongate these globules, giving the iron a fibrous structure, and the reheating and rerolling will drive these fibers closer together, thus increasing the strength and ductility of the metal.

#### Classes and Kinds of Steel.

The word steel, nowadays, covers a multitude of mixtures which are very different from each other in their chemical as well as physical qualities. The ingredient that exerts most influence on these variations is carbon. High grade razor steel contains about  $1\frac{1}{4}$  per cent of carbon, springs 1 per cent, steel rails from  $\frac{1}{2}$  to  $\frac{3}{4}$  per cent, and soft steel boiler plate may go as low as  $\frac{1}{16}$  per cent of carbon. Steel which is very low in carbon can easily be welded, but it cannot be tempered; when carbon is above  $\frac{1}{3}$  per cent, welding is more difficult and can only be done by the use of borax or some other flux, or by electric or thermit welding. Steel with carbon above  $\frac{3}{4}$  per cent can be tempered, that is, when heated to red heat and then quenched in water or other liquid, it becomes very hard and can be used for tools of various kinds, such as saws, files, drills, chisels, cutlery, etc. In tool steel other ingredients are sometimes used to influence its hardness, such as nickel, manganese, chrome, tungsten, etc., the last named playing an important part in so-called "high-speed steels," that is, tool steels that will cut metal at a high speed without losing their temper or hardness.

As stated above, pig iron and cast iron contain about 4 per cent of carbon, and wrought iron only a trace of it, while steel is between these two extremes. The manufacture of steel, therefore, refers principally to getting the right proportion of carbon. One method is to take pig iron and burn the carbon out of it, as in the Bessemer and open-hearth processes, and the other method is to take wrought iron and add carbon to it, as in the cementation and crucible processes.

#### The Bessemer Process.

In the Bessemer process the molten pig iron is put into a large pear-shaped vessel, called the converter, the bottom of which is double, the inner one being perforated with numerous holes, called tuyeres,

to admit air to be forced in under pressure. The molten iron (from 10 to 15 tons at a time) is poured into the converter while the latter is lying on its side; then the compressed air is turned into the double bottom as the converter rises to a vertical position. The air has sufficient pressure (about 20 pounds per square inch) to prevent the molten metal from entering the tuyeres. The air streams pass up through the molten metal (piercing it like so many needles), burning out the carbon, silicon, etc., accompanied by a brilliant display of sparks and a flame shooting out of the mouth of the converter. The 15 tons of molten pig iron contain nearly  $\frac{3}{4}$  of a ton of carbon, and since this carbon is all burned out in less than ten minutes, this rapid rate of combustion increases the heat of the metal very much; it does not cool it, as one would suppose at first thought. The flame, therefore, at first red, becomes brighter and brighter, until it is finally so white that it can scarcely be looked at with the naked eye. A "blow" generally lasts about nine to ten minutes, when the sudden dropping of the flame gives notice that the carbon is all burned out. The metal in the converter is then practically liquid wrought iron, the converter is then laid on its side again, the blast shut off and a certain amount of spiegeleisen or ferromanganese is added in a liquid form so as to give the steel the proper amount of carbon and manganese to make it suitable for the purpose desired. The liquid steel is then poured out into so-called "ingot molds," and the resulting "ingots," while still hot, but no longer liquid, are rolled out into blooms, billets, or rails without any additional reheating except a short sojourn in so-called "soaking pits." In some steel works, where the molten pig iron is taken in large ladle cars direct from the blast furnace to the converter, it is possible to produce rails without adding any fuel to that contained in the molten pig iron, so that the red-hot rail just finished still contains some of the heat given it by the coke in the blast furnace.

#### The Open-hearth Process.

The open-hearth process, sometimes called "the Siemens-Martin process," is similar to the puddling process, but on a much larger scale. The furnaces generally have a capacity of from 40 to 50 tons of molten metal (in some exceptional cases as high as 200 tons); they are heated by gas made from bituminous coal (oil and natural gas have also been used). The gas and the air needed for its combustion are heated to a high temperature (over 1,000 degrees) before entering the combustion chamber, by passing them through so-called regenerative chambers. Owing to this preheating of the gas and the air, a very high temperature can be maintained in the furnace, so as to keep the iron liquid even after it has parted with its carbon. The stirring up of the molten metal is not done by hooks as in the puddling furnace, but by adding to the charge a certain proportion of ore, iron scale, or other oxides, the chemical reaction of which keeps the molten iron in a state of agitation. While in the Bessemer process only pig iron is used, in the open-hearth furnace it is practicable to

use also scrap of wrought iron or steel, as the high temperature in the furnace will readily melt it. When the pig iron or scrap contains too much phosphorus, burnt lime is added to the charge; the resulting slag will absorb the phosphorus, thus taking it out of the metal. This dephosphorization by means of burnt lime is called the basic process in contradistinction to the acid process, where no lime is used, but where care must be taken that the metal charged is low in phosphorus. In this country, the basic process is at present used only in connection with open-hearth furnaces, while in Europe it is also used in many Bessemer plants producing the so-called "basic Bessemer steel."

#### Producing Tool Steel.

Crucible steel or tool steel, formerly called cast steel, is made by using high grade, low phosphorus wrought iron and adding carbon to it. The oldest method is the so-called "cementation process" in which the iron bars are packed in air-tight retorts, with powdered charcoal between the bars. The filled retorts are put into a cementation furnace, where they are heated to a red heat and kept at that temperature for several days, during which time the iron will absorb about  $1\frac{1}{2}$  per cent of its own weight of carbon. The process is similar to the case-hardening process familiar to many blacksmiths. The carbonized bars, called "blister steel," are then cut into small pieces, remelted in a crucible, and from there poured into molds, forming small billets, which are afterward hammered or rolled into the desired shapes. The newer method is to put the small pieces of wrought iron direct into an air-tight crucible mixed with the proper amount of powdered charcoal, and melt down; the iron will absorb the carbon much quicker while in a molten state than when only red-hot, as in the cementation furnace. The other ingredients, such as chrome, tungsten, etc., are also added in the crucible.

#### Malleable and Steel Castings.

Malleable castings are produced in the reverse way from the blister steel referred to above, that is, instead of taking wrought iron and adding carbon, castings made of cast iron are made malleable by extracting the carbon. The castings are packed into retorts similar to the cementation retorts, but, instead of charcoal, an oxide of iron, generally in the shape of hematite ore, is packed with them, and kept in a red-hot state for several days. The oxygen of the ore will absorb the carbon in the iron, giving the latter a somewhat steely nature.

Steel castings used to be produced in the same manner, but now, steel castings are cast direct from the ladle containing molten steel, which is generally melted in an open-hearth furnace, although small Bessemer converters are also sometimes used for this purpose.

#### Difference between Wrought Iron and Low Carbon Steel.

While chemically there is not much difference between wrought iron and low carbon steel, there is considerable difference in their physical structures. Owing to the globules of pure iron being coated with



cinder in the puddling furnace, the subsequent rolling and reworking, while expelling a large portion of this cinder, always leaves a trace of it behind which gives wrought iron the fiber. Steel having been produced in a liquid form, where the cinder all floated to the top and was removed, the metal is homogeneous, that is, without any grain or fiber. When subjected to many vibrations, or strains due to frequent expansion and contraction, wrought iron will generally yield gradually and give warning to the inspector, while steel is more liable to snap off suddenly. Wrought iron being composed of many fibers, the fibers can break one at a time without directly affecting its neighbor (like the strings in a rope), while a rupture once started in steel will extend more rapidly. Wrought iron will also resist corrosion and pitting longer than steel, no doubt due to higher resisting power of the enclosed cinder, which also causes the acid to deflect endwise, thus weakening its action by diffusing it over a larger area and preventing deep pitting. Stay bolts and boiler tubes for locomotives have proved more satisfactory when made of wrought iron than of steel. Thin sheets, tin plate, corrugated iron covering, wire fencing, pipes, oil well casings, etc., have also proved much more durable when made of wrought iron than when made of steel. On the other hand, in rails, tires, guns, armor plate, etc., steel has proved far superior to iron, owing to its greater strength and hardness; corrosion is also here of minor importance, owing to the rails, etc., generally being worn out long before corrosion has a chance to affect them seriously. When structural steel or iron is used for bridges, etc., it is necessary to protect the metal from serious corrosion by frequent and careful painting; in the skeletons of high office buildings and other skyscrapers, when completely covered with concrete, etc., so as to thoroughly exclude air or moisture, steel as well as iron will last indefinitely.

Where material is buried in the ground, or exposed to the weather without the careful protection of paint, or where moisture has access to it by other channels, as in the interior of pipes, for instance, wrought iron will outlast steel by a good margin.

#### Graphical Illustration of the Metallurgy of Iron.

The diagram Fig. 1 illustrates graphically the metallurgy of iron from the mine to the market and affords an interesting means of tracing out the different processes and showing the kind of steel or iron which each process produces. What has been said in the previous part of this chapter is, in a way, summarized in this diagram. Thus we see that the ore may, by the direct process, be changed at once to wrought iron in which form it is placed upon the market. The ore may go direct to the blast furnace or, if volatile substances are contained in the ore, it is first roasted, by which method these substances are removed and the ore made ready for the blast furnace. In the blast furnace the ore is changed to pig iron of various grades which may be placed directly upon the market or it may be then treated by any one of several processes. If treated by the Bessemer

process the pig iron is changed to ingot iron, in which form it is placed upon the market. If treated by the open-hearth process it is also changed to ingot iron. If, however, the pig iron is sent to the foundry it is made into cast iron and placed upon the market in the form of castings. In the puddling furnace the pig iron is changed to marketable wrought iron or it may be treated by the cementation process, in which it is changed to blister steel, from which, by the crucible process, we obtain tool steel.

#### Uniform Nomenclature of Iron and Steel.

At the Brussels Congress of the International Association for Testing Materials held in September, 1906, a report was presented on "The Uniform Nomenclature of Iron and Steel." The following definitions of the most important forms of iron and steel are given:

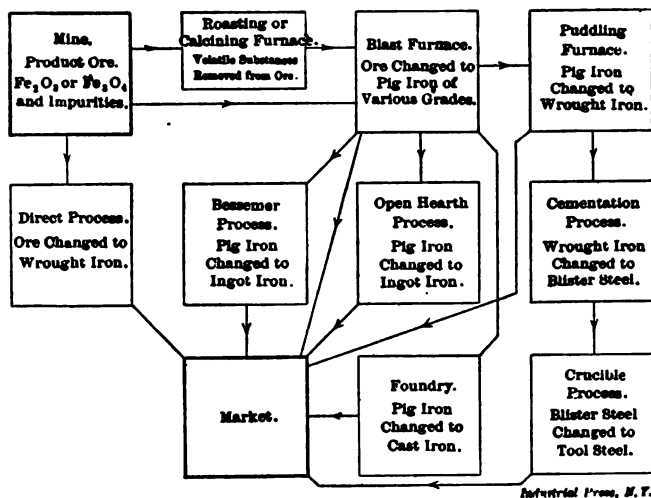

Fig. 1. Chart Illustrating the Metallurgy of Iron.

**Alloy cast irons:** Iron which owe their properties chiefly to the presence of an element other than carbon.

**Alloy steels:** Steels which owe their properties chiefly to the presence of an element other than carbon.

**Basic pig iron:** Pig iron containing so little silicon and sulphur that it is suited for easy conversion into steel by the basic open-hearth process (restricted to pig iron containing not more than 1.00 per cent of silicon).

**Bessemer pig iron:** Iron which contains so little phosphorus and sulphur that it can be used for conversion into steel by the original or acid Bessemer process (restricted to pig iron containing not more than 0.10 per cent of phosphorus).

**Bessemer steel:** Steel made by the Bessemer process, irrespective of carbon content.

**Blister steel:** Steel made by carburizing wrought iron by heating it in contact with carbonaceous matter.

**Cast iron:** Iron containing so much carbon or its equivalent that it is not malleable at any temperature. The committee recommends drawing the line between cast iron and steel at 2.20 per cent carbon.

**Cast steel:** The same as crucible steel; obsolete, and to be avoided because confusing.

**Converted steel:** The same as blister steel.

**Charcoal hearth cast iron:** Cast iron which has had its silicon and usually its phosphorus removed in the charcoal hearth, but still contains so much carbon as to be distinctly cast iron.

**Converted steel:** The same as blister steel.

**Crucible steel:** Steel made by the crucible process, irrespective of carbon content.

**Gray pig iron and gray cast iron:** Pig iron and cast iron in the fracture of which the iron itself is nearly or quite concealed by graphite, so that the fracture has the gray color of graphite.

**Malleable castings:** Castings made from iron which when first made is in the condition of cast iron, and is made malleable by subsequent treatment without fusion.

**Malleable iron:** The same as wrought iron.

**Malleable pig iron:** An American trade name for the pig iron suitable for converting into malleable castings through the process of melting, treating when molten, casting in a brittle state, and then making malleable without remelting.

**Open-hearth steel:** Steel made by the open-hearth process irrespective of carbon content.

**Pig iron:** Cast iron which has been cast into pigs direct from the blast furnace.

**Puddled iron:** Wrought iron made by the puddling process.

**Puddled steel:** Steel made by the puddling process, and necessarily slag-bearing.

**Refined cast iron:** Cast iron which has had most of its silicon removed in the refinery furnace, but still contains so much carbon as to be distinctly cast iron.

**Shear steel:** Steel, usually in the form of bars, made from blister steel by shearing it into short lengths, piling, and welding these by rolling or hammering them at a welding heat. If this process of shearing, piling, etc., is repeated, the product is called "double shear steel."

**Steel:** Iron which is malleable at least in some one range of temperature, and in addition is either (a) cast into an initially malleable mass; or, (b) is capable of hardening greatly by sudden cooling; or, (c) is both so cast and so capable of hardening.

**Steel castings:** Unforged and unrolled castings made of Bessemer, open-hearth, crucible or any other steel.

**Washed metal:** Cast iron from which most of the silicon and phosphorus have been removed by the Bell-Krupp process without removing much of the carbon, so that it still contains enough carbon to be cast iron.

**Weld iron:** The same as wrought iron; obsolete and needless.

*White pig iron and white cast iron:* Pig iron and cast iron in the fracture of which little or no graphite is visible, so that their fracture is silvery and white.

*Wrought iron:* Slag-bearing, malleable iron, which does not harden materially when suddenly cooled.

## CHAPTER II.

### STEEL CASTINGS.

The present chapter consists of an abstract published in the June, 1903, issue of *MACHINERY* of an article which originally appeared in the journal of the *American Society of Naval Engineers*, February, 1903.

The raw materials that usually enter into the making of steel castings are steel scrap, pig iron and iron ore. The scrap consists of the crop ends of plates, shapes and forgings and the borings and turnings from the machine shop. The bulk of the furnace charge is scrap, the proportion of pig being about one-fifth at the beginning of a run—that is, immediately after a furnace has been rebuilt—and increasing up to nearly three-tenths at the end of the run, when the furnace lining and brick work generally are getting so slagged and burnt out as to require renewal. These proportions are for acid steel, basic steel using larger quantities of pig. The amount of iron in the ore is a secondary consideration, the ore being used chiefly for its oxygen, which comes into play in oxidizing the metalloids carbon, silicon, sulphur, and phosphorus. The proportions of ore required in a charge depends upon the character of the other ingredients; ordinarily in an acid furnace from one to two, or two and a half per cent would be used. There have been cases where scrap could not be procured, and the charge has been made up, of necessity, entirely of pig and ore, over three-fifths being pig. Hematite ore is the variety most used, and is obtained in large quantities in the Lake Superior region in this country and Canada; much of it is also imported from Cuba, Spain and elsewhere.

The amount of carbon combined with iron makes one difference between wrought iron and steel and between steel and cast iron. A second and equally important difference is the method of manufacture and the resulting properties and character. Wrought iron is soft and fibrous; cast iron is hard, crystalline and brittle; steel comes in anywhere between.

Basic steel is used in making castings, but not so generally as the acid product. Cheaper raw materials can be used in making basic steel, and phosphorus, the element chiefly objected to, can be nearly eliminated. It is more expensive than acid steel, however, and fewer

heats per run of furnace can be turned out. With acid steel the number of heats will reach nearly three for each twenty-four hours, depending upon the size of furnace and character and quantity of work.

#### Open-hearth Furnaces.

The raw materials are melted down in a reverberatory furnace with gaseous fuel distilled from special bituminous coals in gas producers. Under each end of the furnace is a pair of regenerators—one for air, one for gas—which communicate with the furnace on one side and on the other with flues leading to the sources of supply of gas and air to the chimney. Reversing valves are located at the point where the flues meet, and about every twenty minutes, while the furnace is in operation, the valves are shifted and the currents of air and gas turned in the opposite direction. Each regenerator is nearly filled with fire brick built up in such an open checker-board manner that the air and gas find their way among and through them, absorbing heat from them on their way to the hearth, and, when spent, giving up heat to those in the opposite regenerators.

With this type of furnace a temperature of 4,000 degrees Fahrenheit can be attained, but as the supply of gas and air is at all times under control, the temperature can be made whatsoever may be desired. The process in the furnace will be acid or basic according to the character of the furnace lining—basic linings and additions being used in one case, and an acid lining, such as ordinary fire brick and fire clay, in the other.

#### Tests on Steel Castings.

Castings requiring annealing are placed in annealing furnaces, where they are gradually and uniformly heated up to temperatures depending upon the composition of the metal and varying between 1,200 and 1,600 degrees Fahrenheit, kept soaking at the maximum temperature for a time determined by their size, and allowed gradually to cool without exposure to the air. When cold the necessary test specimens are cut from them and machined accurately to required size. These specimens are then broken or bent in an approved testing machine according to the specifications prescribed. The Bureau of Steam Engineering of the Navy Department prescribes the following regarding the testing of steel castings: Sound test pieces shall be taken in sufficient number to thoroughly exhibit the character of the metal in the entire piece from each of the following castings, *viz.*: Shaft struts or brackets, main cylinder or valve-chest liners, main pistons and followers, eccentric, reversing and rocker shaft arms, cross-heads, bedplates, columns of main engines and main air pumps, shaft couplings, and all large castings weighing over 200 pounds. All other castings may be tested by lots, as follows: A lot shall consist of all castings from the same heat, annealed in the same furnace charge. From each lot two or more tensile and one or more bending test pieces shall be taken, and the lot passed or rejected on the results shown by the tests. Large castings shall be suspended and hammered all

over with a hammer weighing not less than  $7\frac{1}{2}$  pounds. No cracks, flaws, defect or weakness shall appear after such treatment.

The tensile strength of high-class steel castings varies from 65,000 pounds to 80,000 pounds per square inch. The percentage of elongation in two inches varies from 15 to 18 per cent, and the reduction of area from 20 to 25 per cent.

#### Uses of Steel Castings.

Steel castings are used for cylinder and valve-chest covers, for pistons, crosshead guides and slippers, bearing caps and shoes, eccentric sheaves and straps, rocker arms, thrust-bearing boxes and collars, bedplates and housings and other parts of main and auxiliary machinery; for boiler headers, manifolds, drum ends, dry pipes, manhole and handhole doors and other parts of boilers; anchors, anchor davits, hawse pipes, chocks, mooring and towing bits, stems, stern posts, stern tubes, shaft brackets, manhole covers and other parts of ships' hulls, gun mounts, parts of dynamos and motors. Their use in ship construction and aboard ship is thus seen to be a large and important matter.

The cast-steel girders for the 16-inch U. S. army gun carriage measure 35 feet by 17 feet by 5 feet, and will weigh 100,000 pounds apiece; the carriage presents problems in transportation from the foundry to the arsenal at Watervliet on account of size and weight. A large casting turned out in the eastern part of Pennsylvania for a hydraulic forging press to be set up in the western part of the same State required about 320,000 pounds of metal from six open-hearth furnaces to pour it.

#### Reliability of Steel Castings.

A forged or rolled object is worked down from a billet which previously was hammered or pressed down from an ingot or part of an ingot, and during these stages of manufacture the metal is more or less thoroughly squeezed and pressed and caused to flow upon itself in various directions, and all parts, inside and out, receive some heat and power treatment, so that the impression grows in the minds of those who manipulate the forgings and of those who witness the manipulation that the accepted objects are free from weakening defects; the assurance of their trustworthiness is positive.

In the case of castings no such certainty or confidence is created. A steel casting may come out of the final cleaning process a thing of beauty, the physical and chemical tests may gladden the heart, the required machining may not show any flaws, yet the fear remains that below its surface somewhere a treacherous cavity or other weakness may some day show up—a day when most dependence is necessarily placed upon the casting, when most damage may result from its failure to do its duty.

## CHAPTER III.

### STEEL HARDENING METALS.

In the 1904 issue of "Mineral Resources of the United States," published by the U. S. Geological Survey, a paper appeared written by Mr. Joseph Hyde Pratt, on the Steel Hardening Metals. An abstract of this was published in the May, 1905, issue of MACHINERY.

There are included under the head of steel-hardening metals, nickel and cobalt, chromium, tungsten, molybdenum, vanadium, titanium, and uranium, which are named in the order of the importance of their production and use for steel-hardening purposes.

The special steels resulting from these additions vary among themselves, having individual properties of tensile strength and elastic limit, of conductivity for heat and electricity, of magnetic capacity and of resistance to impact, whether as shell or as armor plate. It was only about twenty years ago that the first of these metals, nickel, began to be used to any extent for the purpose of hardening steel, but since their introduction their use for this purpose has continued to increase steadily. Experiments are still being carried on with some of these metals in order to determine their actual commercial value with regard to the qualities that they impart to steel. In the arts it is the ferro-alloy of these various metals that is first prepared and is then introduced in the required quantity into the manufactured steel, but this ferro-alloy is never added to the molten mass during the manufacture of the steel. All these metals give characteristic and distinct properties to steel, but in all cases the principal quality is the increase in the hardness and the toughness of the resulting steel. Some of the metals—as nickel, chromium and tungsten—are now entirely beyond the experimental stage and are well established in the commercial world as definite steel-hardening metals, and new uses are being constantly devised for the different steels, which are causing a constant increase in their production. Others, as molybdenum and vanadium, though they have been proved to give certain positive values to steel, have not been utilized to any large extent as yet in the manufacture of molybdenum or vanadium steel, partly on account of the high cost of the ores containing these metals. Titanium and uranium are still in the experimental stage, and, although a good deal has been written as to the value of titanium as an alloy with steel, there is at the present time very little if any of it used in the manufacture of a commercial steel.

Since the introduction of the electric furnace and the consequent methods that have been devised for reducing ores, it has become possible to obtain these ferro-alloys directly from the ores by reducing them in the electric furnace, and hence experiments have been conducted on a much larger scale than formerly.

### Manganese Steel.

Besides the use of ferromanganese for the chemical effect which it produces in the manufacture of steel in eliminating injurious substances, it is also used in the production of a special steel which possesses to a considerable degree combined hardness and toughness. Such steel contains from 0.8 to 1¼ per cent of carbon and about 12 per cent of manganese and is known as "Hadfield manganese steel." If only 1.5 per cent of manganese is added, the steel is very brittle, and the further addition increases this brittleness until the quantity of manganese has reached 4 to 5.5 per cent, when the steel can be pulverized under the hammer. With a further increase, however, of the quantity of manganese, the steel becomes ductile and very hard, reaching its maximum degree of these qualities with 12 per cent of manganese. The ductility of the steel is brought out by sudden cooling, a process the opposite of that used for carbon steel. These properties of manganese steel make it especially adapted for use in the manufacture of rock-crushing machinery, safes, and mine car wheels.

### Nickel Steel.

Nickel finds its largest use in the manufacture of special nickel and nickel-chromium steels, and the use of these steels for various purposes in the arts is constantly increasing. The greatest quantity of nickel steel is used in the manufacture of armor plate, either with or without the addition of chromium. There is probably no armor or protective deck-plate made which does not contain from 3 up to 5 per cent of nickel. Nickel steel is also used for the manufacture of ammunition hoists, communication tubes, and turrets on battleships, and for gun shields and armor.

The properties of nickel steel or nickel-chromium steel that make it especially adapted for these purposes are its hardness and great tensile strength, combined with great ductility and a very high limit of elasticity. One of the strongest points in favor of a nickel steel armor plate is that when it is perforated by a projectile it does not crack. The Krupp steel, which represents in composition about the universal armor-plate steel, contains, approximately, 3.5 per cent of nickel, 1.5 per cent of chromium, and 0.25 per cent of carbon.

Another use for nickel steel that is gradually increasing is the manufacture of nickel steel rails. During 1903 there were over 11,000 tons of these rails manufactured, which were used by the Pennsylvania, the Baltimore & Ohio, the New York Central, the Bessemer & Lake Erie, the Erie, and the Chesapeake & Ohio railroads. These orders for nickel steel rails resulted from the comparison of nickel steel and carbon-steel rails in their resistance to wear during the five months' trial of the nickel steel rails that were used on the Horseshoe Curve of the Pennsylvania Railroad. The advantages that are claimed for the nickel steel rail are its increased resistance to abrasion and its higher elastic limit, which increases the value of the rail as a girder. On sharp curves it has been estimated that a nickel steel rail will outlast four ordinary rails.



Nickel steel has also been largely adopted for forgings in large engines, particularly marine engines, and it is understood that this is now the standard material for this purpose in the United States navy. There is now a very great variety of these forgings and drop forgings, including the axles and certain other parts of automobiles, shafting and crank-shafts for government and merchant-marine engines and stationary engines, and locomotive forgings, the last including axles, connecting-rods, piston-rods, crank-pins, link-pins, and pedestal cap bolts, and for sea-water pumps.

Another important application that is being tried with nickel steel is in the manufacture of wire cables, and during the last years such cables have been made by the American Steel and Wire Co., but no comparison can as yet be made between them and the ordinary carbon-steel cables with respect to their wearing qualities.

In the manufacture of electrical apparatus nickel steel is beginning to be used in considerable quantity. The properties of this steel which make it especially valuable for such uses are, first, its high tensile strength and elastic limit, and, second, its high permeability at high inductions. Thus steel containing from 3 to 4 per cent of nickel has a lower permeability at low inductions than a steel without the nickel, but at the higher inductions the permeability is higher. A notable instance of the use of this material is in the field rings of the 5,000 H. P. generators built by the Westinghouse Electric and Manufacturing Co. for the Niagara Falls Power Co. These field rings require very high tensile strength and elastic limit, and in order to reduce the quantity it is desirable that they have high permeability at high inductions. This result was secured by using a nickel steel containing approximately 3.75 per cent of nickel. Steel containing approximately 25 per cent of nickel is nonmagnetic and has a very low resistance temperature coefficient. This property is occasionally of value where a nonmagnetic material of very high tensile strength is required. The high electrical resistance of nickel steel of this quality, together with its low temperature coefficient, makes it valuable for electrical resistance work where a small change in the resistance due to change in temperature is desirable. The main objection to using nickel steel for this purpose is the mechanical defects that are often found in wire that is drawn for this quality of nickel steel.

For rock drills and other rock-working machinery nickel steel is used in the manufacture of the forgings which are subjected to repeated and violent shocks. The nickel content of the steel used in these forgings is approximately 3 per cent, with about 0.40 per cent of carbon. The rock drills or bits are made for the most part of ordinary crucible cast steel which has been hardened and tempered. There is a field for investigation here in respect to the value of some of the special drills in the manufacture of rock-drill steels or bits. A nickel-chrome steel is now being made which is used to some extent in the manufacture of tools.

Nickel steel in the form of wire has been used quite extensively and for many purposes—for wet mines, torpedo defense netting, elec-

tric lamp wire, umbrella wire, corset wire, etc.—where a non-corrosive wire is especially desired. When a low coefficient of expansion is desired—as in the manufacture of armored glass, in the mounting of lenses, mirrors, level tubes, balances for clocks, weighing machines, etc.—nickel steel gives good satisfaction. For special springs, both in the form of wire and flats, a high carbon nickel steel has been introduced to a considerable extent. Nickel steel is also being used in the manufacture of dies and shoes for stamp mills, for cutlery, table ware, harness mountings, etc.

Nickel steels containing from 25 to 30 per cent nickel are used abroad to a considerable extent for boiler and condenser tubes and are now being introduced into this country. The striking characteristic of these steels is their resistance to corrosion either by fresh, salt, or acid waters, by heat, and by superheated steam. The first commercial manufacture of high nickel steel tubes began in France in 1898, and was followed in Germany in 1899; but it was not until February, 1903, that these tubes were made in the United States. Since then, however, Mr. Albert Ladd Colby states:

“The difficulties of their manufacture have been so thoroughly overcome that the 30 per cent nickel-steel, seamless, cold-drawn marine boiler tubes, now a commercial proposition, are made in practically the same number of operations, and with but a slightly greater percentage of discard than customary in the manufacture of ordinary seamless tubes, and, furthermore, the finished 30 per cent nickel-steel tube will stand all the manipulating tests contained in the specifications of the Bureau of Steam Engineering, United States Navy Department, for the acceptance of the carbon-steel seamless cold-drawn marine boiler tubes now in use. In addition, the nickel-steel tubes have a much greater tensile strength.”

Although the first cost of the nickel steel tubes for marine boilers is considerably in excess of the carbon-steel tubes, yet, on account of the longer life of the nickel-steel tubes, they are in the end cheaper than the others. At the present time 30 per cent nickel-steel tubes cost from 35 cents to 40 cents per pound, as compared with 12 cents to 15 cents per pound for the corresponding mild carbon-steel tubes. Thus their initial cost, when used in the boilers of torpedo-boat destroyers, is 2.13 times as great as the other kind and 2.43 times as great when used in the boilers of battleships, but the nickel steel tubes will last two-and-one-third times longer than those made of the carbon steel, and when finally taken from the boilers they can be sold not only for the market price of steel-tubing scrap, but also at an additional price of 20 cents per pound for their nickel content. Thus it is seen that 30 per cent nickel-steel boiler tubes are really more economical to purchase than carbon-steel boiler tubes.

In addition to marine boilers, high nickel-steel tubes can be used to advantage for stationary boilers, automatic boilers, and locomotive safe ends. It is the higher elastic limit of the 30 per cent nickel-steel boiler tubing that will prevent the leaks that are constantly being formed where the mild carbon-steel tube is used. The leaks are due

to the expansion of the flue-sheets when heated, which compress the tubes at the points where they pass through the flue-sheets, and cause in the case of the mild carbon-steel tube a permanent deformation. This results in leakage and necessitates the frequent expanding of the tubes. In the high nickel-steel tubes this difficulty is overcome by their higher elastic limit. This deformation and the resulting leakage are especially true of locomotive boilers. For automobile tubular boilers a 23 to 25 per cent nickel-steel tubing is used, each coiled section being made from one long piece of nickel-steel tubing, which, by a special heat treatment, is enabled to withstand this bending without cracking.

Nickel-steel tubing containing 12 per cent of nickel has been used in France since 1898 in the manufacture of axles, brake beams, and carriage transoms for field artillery wagons, and the desired result in the reduction of weight has been obtained without loss of strength and stiffness of the wagons. A 5 per cent nickel-steel tubing has been used in the manufacture of bicycles since 1896.

#### Chromium Steel.

The largest use of chromium is in the manufacture of a ferro-chromium alloy which is used in the manufacture of chrome steel. In the manufacture of armor plate ferro-chrome plays a very important part, and, although it is sometimes used alone for giving toughness and hardness to the armor plate, it is more commonly used in combination with the nickel, making a nickel-chromium-steel armor plate. Other uses of chrome steel are in connection with five-ply welded chrome steel and iron plates for burglar-proof vaults, safes, etc., and for castings that are to be subjected to unusually severe service, such as battery shoes and dies, wearing plates for stone crushers, etc. A higher chromium steel which is free from manganese will resist oxidation and the corrosive action of steam, fire, water, etc., to a considerable extent, and these properties make it valuable in the manufacture of boiler tubes. Chromium steel is also used to some extent as a tool steel, but for high-speed tools it is being largely replaced by tungsten steel, which is especially adapted to this purpose.

The percentage of chromium that is used in the chromium steels varies from 2.5 to about 5 per cent and the carbon from 0.8 to 2 per cent. The hardness, toughness and stiffness which are obtained in chromium steel are very essential qualities, and are what make this steel especially beneficial for the manufacture of armor-piercing projectiles as well as of armor plate. For projectiles, chromium steel has thus far given better satisfaction than any of the other special steels, and is practically the only steel that is used for this purpose. The value of chromium steel for this purpose is well brought out by Mr. R. A. Hadfield, manager of the Hecla Works, Sheffield, England, who states that a 6-inch armor-piercing shot made by this firm was fired at a 9-inch compound plate, which it perforated unbroken. It was then fired again from the same gun and perforated a second plate of the same thickness, the shot still remaining unbroken.

### **Tungsten Steel.**

Tungsten steel is used to some extent more generally abroad than in the United States, in the manufacture of armor plate and armor-piercing projectiles. For this purpose it is used in combination either with nickel or chromium, or with both of these metals. The use, however, for which tungsten steel is best adapted is in the manufacture of high-speed tools and magnet steels. The property that tungsten imparts to the steel is that of hardening in the air after forging and without recourse to the usual methods of tempering, such as immersion in oil, water, or some special solution. For high-speed tools tungsten steel is especially adapted, as it retains its hardness and cutting edge even at the temperature developed in the use of these high-speed tools. The value of tungsten steel for permanent magnets is on account of it retaining comparatively strong magnetism and of the permanence of this magnetism in the steel. This property makes the tungsten steel particularly desirable in instrument work where the calibration of the instrument depends upon the permanence of the magnet used. For compass needles, tungsten steel has been used with entire satisfaction.

### **Molybdenum.**

The use of molybdenum steel continues to increase, and hence there is an increasing demand for the ores of this metal. The main use of ferromolybdenum is in the manufacture of tool steel. The properties which molybdenum gives to steel are very similar to those given by tungsten, the main difference being that it requires a smaller quantity of molybdenum than of tungsten to acquire the same results. Ferromolybdenum is produced, like ferrotungsten, by reducing it from the ore in an electric furnace. There are now two molybdenum-nickel alloys being produced, one of which contains 75 per cent molybdenum and 25 per cent nickel, and the other 50 per cent molybdenum and 50 per cent nickel. Besides these constituents the alloy contains from 2 to 2.5 per cent iron, 1 to 1.5 per cent carbon, and 0.25 to 0.50 per cent silicon. The molybdenum steel which is made from these alloys is recommended for large cranks and propeller-shaft forgings, for large guns, rifle barrels, and for wiring and for boiler plates. The molybdenum increases the elongation of steel very considerably, and for wire drawing such an increase at a comparatively small cost is important.

### **Vanadium Steel.**

On account of the extremely high price and scarcity of vanadium ores, the metal has thus far been employed very little in the manufacture of ferrovanadium for use in the production of vanadium steel. It is claimed by many that the beneficial properties imparted to steel by vanadium exceed those of any of the other steel hardening metals. These are exaggerated statements, but it may be found that smaller quantities of vanadium will give in some cases the same results that are obtained by comparatively large quantities of the other metals. One property claimed for vanadium steel is that it acquires its maxi-

imum of hardness not by sudden cooling, but by annealing at a temperature of from 1,300 to 1,470 degrees F. This property would be particularly advantageous for high-speed tool steel and for points of projectiles.

#### Titanium.

The actual commercial value of titanium as a steel-hardening metal has not been thoroughly demonstrated. Experiments have shown that from 0.5 to 3 per cent of titanium increases the transverse strength and the tensile strength of steel to a very remarkable degree. Until the development of the electric furnace it was practically impossible to produce either titanium or an alloy of iron and titanium, but since the introduction of this furnace, ferrotitanium can be produced directly from the ores. It is to the manufacture of a special cast iron that ferrotitanium seems to be especially adapted. The titanium in the iron gives greater density to the metal, greatly increases its transverse strength, and gives a harder chill or wearing quality to a wheel made from such an iron. For the manufacture of car wheels it would seem that the titanium iron would be especially useful.

## CHAPTER IV.

### DEVELOPMENT AND USE OF HIGH SPEED STEEL.

The following discussion on high-speed steel and tools made from this material was published in *MACHINERY* in the December, 1904, issue, and is an abstract of a paper read by Mr. J. M. Gledhill before the Iron and Steel Institute, of Great Britain, October, 1904.

The high-speed steels of the present day are combinations of iron and carbon with: (1) Tungsten and chromium, (2) Molybdenum and chromium, (3) Tungsten, molybdenum and chromium.

#### Influence of Carbon.

A number of tool steels were made by the Armstrong Whitworth Co. with the carbon percentage varying from 0.4 per cent to 2.2 per cent, and the method of hardening was to heat the steel to the highest possible temperature without destroying the cutting edge, and then rapidly cooling in a strong air blast. By this simple method of hardening it was found that the greatest cutting efficiency is obtained where the carbon ranges from 0.4 per cent to 0.9 per cent, and such steels are comparatively tough. Higher percentages are not desirable because great difficulty is experienced in forging the steels, and the tools are inferior. With increasing carbon contents the steel is also very brittle, and has a tendency to break with unequal and intermittent cutting.

#### **Influence of Chromium.**

Having thus found the best carbon content to range from 0.4 per cent to 0.9 per cent, the next experiments were made to ascertain the influence of chromium varying from 1.0 per cent to 6.0 per cent. Steels containing a low percentage are very tough, and perform excellent work on the softer varieties of steel and cast-iron, but when tried on harder materials the results obtained were not so efficient. With an increased content of chromium the nature of the steel becomes much harder, and greater cutting efficiency is obtained on hard materials. It was observed that with an increase of chromium there must be a decrease in carbon to obtain the best results for such percentage of chromium.

Mention may here be made of an interesting experiment to ascertain what effect would be produced in high-speed steel by substituting vanadium for chromium. The amount of vanadium present was 2.0 per cent. The steel readily forged, worked very tough, and was hardened by heating to a white heat and cooling in an air blast. This tool when tried on medium steel stood well, but not better than the steel with the much cheaper element of chromium in it.

#### **Influence of Tungsten.**

This important element is contained in by far the greater number of the present high-speed steels in use. A number of experiments were made with the tungsten content ranging from 9.0 per cent to 27.0 per cent. From 9.0 per cent to 16.0 per cent the nature of the steel becomes very brittle, but at the same time the cutting efficiency is greatly increased, and about 16.0 per cent appeared to be the limit, as no better results were obtained by increasing the tungsten beyond this figure. Between 18.0 per cent and 27.0 per cent it was found that the nature of the steel altered somewhat, and instead of being brittle, it became softer and tougher, and whilst such tools have the property of cutting very cleanly, they do not stand up so well.

#### **Influence of Molybdenum.**

The influence of this element at the present time is under investigation, and the experiments with it have so far produced excellent results; it has been found that where a large percentage of tungsten is necessary to make a high-speed steel, a considerably less percentage of molybdenum will suffice. A peculiarity of these molybdenum steels is that in order to obtain the greatest efficiency they do not require such a high temperature in hardening as do the tungsten steels, and if the temperature is increased above 1,800 degrees F. the tools are inferior, and the life shortened.

#### **Influence of Tungsten with Molybdenum.**

It was found that the presence of from 0.5 per cent to 3.0 per cent molybdenum in a high tungsten steel slightly increased the cutting efficiency, but the advantage gained is altogether out of proportion to the cost of the added molybdenum.

### Influence of Silicon.

A number of high-speed steels were made with silicon content varying from a trace up to 4.0 per cent. Silicon sensibly hardens such steels, and the cutting efficiency on hard materials is increased by additions up to 3.0 per cent. By increasing the silicon above 3.0 per cent, however, the cutting efficiency begins to decline. Various experiments were made with other metals as alloys, but the results obtained were not sufficiently good by comparison with the above to call for comment.

An analysis of one of the best qualities of high-speed steels produced by the author's firm (Armstrong, Whitworth Co.) is as follows: "A.W." Steel.—Carbon, 0.55 per cent; Chromium, 3.5 per cent; Tungsten, 13.5 per cent.

What may be said to determine a high-speed steel, as compared to an ordinary tool steel, is its capability of withstanding the higher temperatures produced by the greatly increased friction between the tool and the work due to the rapid cutting. An ordinary carbon steel containing, say, 1.20 per cent carbon when heated slightly above the critical point and rapidly cooled by quenching in water becomes intensely hard. Such a steel gradually loses this intense hardness as the temperature of friction reaches, say, 500 degrees F. The lower the temperature is maintained the longer will be the life of the tool, so that the cutting speed is very limited. With rapid cutting steels the temperature of friction may be greatly extended, even up to 1,100 degrees F. or 1,200 degrees F., and it has been proved by experience that the higher the temperature for hardening is raised above the critical point and then rapidly cooled, the higher will be the temperature of friction that the tool can withstand before sensibly losing its hardness. The high degree of heating (almost to the melting point, in fact) which is necessary for hardening high-speed steel, forms an interesting study in thermal treatment and is indeed a curious paradox, quite inverting all theory and practice previously existing. In the case of hardening ordinary carbon steels very rapid cooling is absolutely necessary, but with high-speed steels the rate of cooling may take a considerably longer period, the intensity of hardness being increased with the quicker rate of cooling.

### Heat Treatment of High-Speed Steel.

Turning now to some points in the heat treatment of high-speed steel, one of the most important is the process of thoroughly annealing it after working into bars. Accurate annealing is of much value in bringing the steel to a state of molecular uniformity, thereby removing internal strains that may have arisen, due to casting and tilting, and at the same time annealing renders the steel sufficiently soft to enable it to be machined into any desired form for turning tools, milling cutters, drills, taps, threading dies, etc. The annealing of high-speed steel is best carried out in muffle furnaces designed for heating by radiation only, a temperature of 1,400 degrees F. being maintained from twelve to eighteen hours according to the section of the bars of steel dealt with. Further advantage also results from

Careful annealing by minimizing risks of cracking when the steel has to be reheated for hardening. In cases of intricately-shaped milling tools having sharp square bottom recesses, fine edges, or delicate projections, and on which unequal expansion and contraction are liable to operate suddenly, annealing has a very beneficial effect toward reducing cracking to a minimum. Increased ductility is also imparted by annealing, and this is especially requisite in tools that have to encounter sudden shocks due to intermittent cutting, such as planing and slotting tools, or others suddenly meeting projections or irregularities on the work operated on.

In preparing high-speed steel ready for use the process may be divided principally into three stages: forging, hardening, and grinding. It is, of course, very desirable that high-speed steel should be capable of attaining its maximum efficiency and yet only require treatment of the simplest kind, so that an ordinarily skilled workman may easily deal with it, otherwise the preparation of tools becomes an expensive and costly matter, and materially reduces the advantages resulting from its use. Fortunately, the treatment of high-speed steel as produced by leading firms is of the simplest; simpler in fact than of ordinary carbon steels or of the old self-hardening steels. Great care has to be exercised in the heating of the latter steels, for if either are heated above a blood-red heat, say 1,600 degrees F., the danger of impairing their efficiency by burning is considerable; whereas with the high-speed steel, heating may be carried to a much higher temperature, even to the melting point, it being practically impossible to injure it by burning. The steel may be raised to a yellow heat for forging, say 1,850 degrees F., at which temperature it is soft and easily worked into any desired form, the forging proceeding until the temperature lowers to a good red heat, say 1,500 degrees F., when work on it should cease and the steel be reheated.

In heating a bar of high-speed steel preparatory to forging (which heating is best done in a clear coke fire) it is essential that the bar be heated thoroughly and uniformly, so as to ensure that the heat has penetrated to the center of the bar, for if the bar be not uniformly heated, leaving the center comparatively cold and stiff, while the outside is hot, the steel will not draw or spread out equally, and cracking will probably result. A wise rule in heating is to "hasten slowly."

It is not advisable to break pieces from the bar while cold, the effect of so doing tending to induce fine end cracks to develop which ultimately may extend and give trouble; but the pieces should be cut off while the bar is hot, then be reheated as before and forged to the shape required, after which the tool should be laid in a dry place until cold.

The temperature for hardening high-speed steel varies somewhat according to the class of tool being dealt with. When hardening turning, planing, or slotting tools, and others of similar class, the point or nose of tool only should be gradually raised to a white melting heat, though not necessarily melted; but no harm is done even if the point of the tool becomes to a greater or less extent fused or melted.



The tool should then be immediately placed in an air blast and cooled down, after which it only requires grinding and is then ready for use. Another method, which may be described, of preparing the tools is as follows: Forge the tools as before, and when quite cold grind to shape on a *dry* stone or *dry* emery wheel, an operation which may be done with the tool fixed in a rest and fed against the stone or emery wheel by a screw, no harm resulting from any heat developed at this stage. The tool then requires heating to a white heat, but just short of melting, and afterward complete cooling in the air blast. This method of first roughly grinding to shape also lends itself to cooling the tools in oil, which is specially efficient where the retention of a sharp edge is a desideratum, as in finishing tools, capstans and automatic lathe

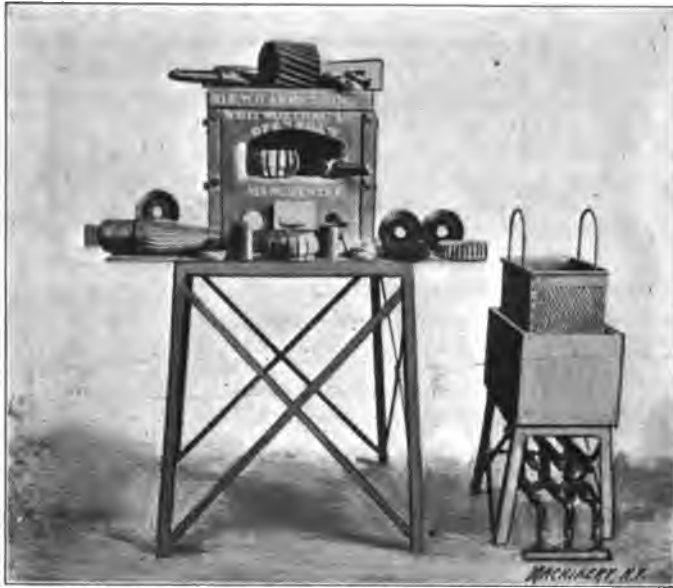

Fig. 2. Muffle Furnace for Hardening Milling Cutters made of High-Speed Steel; also Tank and Dipping Cage for Tempering them in Oil.

tools, brass-workers' tools, etc. In hardening where oil cooling is used, the tools should be first raised to a white heat, but without melting, and then cooled down either by air blast or in the open to a bright red heat, say 1,700 degrees F., when they should be instantly plunged into a bath of rape or whale oil, or a mixture of both.

Referring to the question of grinding tools, nothing has yet been found so good for high-speed steels as the wet sandstone, and the tools ground thereon by hand pressure, but where it is desired to use emery wheels it is better to roughly grind the tools to shape on a dry emery wheel or dry stone *before* hardening. By so doing the tools require but little grinding after hardening, and only slight frictional heating occurs, but not sufficient to draw the temper in any way, and thus the

cutting efficiency is not impaired. When the tools are ground on a wet emery wheel and undue pressure is applied, the heat generated by the great friction between the tool and the emery wheel causes the steel to become hot, and water playing on the steel while in this heated condition tends to produce cracking.

With regard to the hardening and tempering of specially formed tools of high-speed steel, such as milling and gear cutters, twist drills, taps, threading dies, reamers, and other tools that do not permit of being ground to shape after hardening, and where any melting or fusing of the cutting edges must be prevented, the method of hardening is as follows:

A specially arranged muffle furnace heated either by gas or oil is employed, and consists of two chambers lined with fire-clay, the gas and air entering through a series of burners at the back of the furnace, and so under control that a temperature up to 2,200 degrees F. may be steadily maintained in the lower chamber, while the upper chamber is kept at a much lower temperature. Before placing the cutters in the

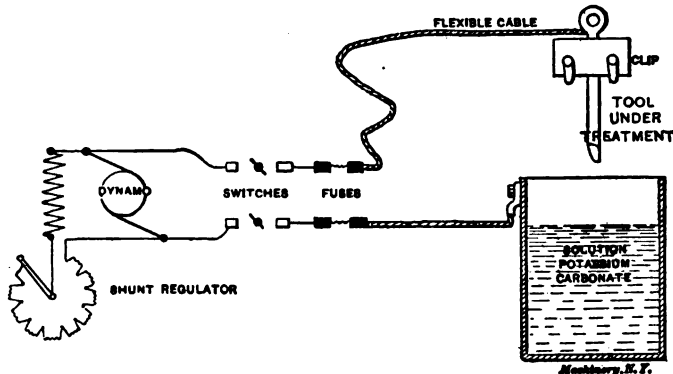

Fig. 3. Apparatus for Hardening Tools Electrically in a Bath of Potassium Carbonate.

furnace it is advisable to fill up the hole and keyways with common fire-clay to protect them. The cutters are first placed upon the top of the furnace until they are warmed through, after which they are placed in the upper chamber, Fig. 2, and thoroughly and uniformly heated to a temperature of about 1,500 degrees F., or, say, a medium red heat, when they are transferred into the lower chamber and allowed to remain therein until the cutter attains the same heat as the furnace itself, *viz.*, about 2,200 degrees F. and the cutting edges become a bright yellow heat, having an appearance of a glazed or greasy surface. The cutter should then be withdrawn while the edges are sharp and uninjured, and revolved before an air blast until the red heat has passed away, and then while the cutter is still warm—that is, *just* permitting of its being handled—it should be plunged into a bath of tallow at about 200 deg. F. and the temperature of the tallow bath then raised to about 520 degrees F., on the attainment of which the cutter should be immediately withdrawn and plunged in cold oil.

Of course there are various other ways of tempering, a good method being by means of a specially arranged gas-and-air stove into which the articles to be tempered are placed, and the stove then heated up to a temperature of from 500 degrees F. to 600 degrees F., when the gas is shut off and the furnace with its contents allowed to slowly cool down.

#### Heating Steel by Electrical Means.

Another method of heating tools is by electrical means, by which very regular and rapid heating is obtained, and where electric current is available, the system of electric heating is quick, reliable, and economical. A brief description of this kind of heating may be of interest. One method adopted of electrically heating the points of tools, and the arrangement of apparatus, is shown in Fig. 3. It consists of a cast-iron tank, of suitable dimensions, containing a strong solution of potassium carbonate, together with a dynamo, the positive cable from which is connected to the metal clip holding the tool to be heated, while the negative cable is connected direct on the tank. The tool to be hardened is held in a suitable clip to ensure good contact.

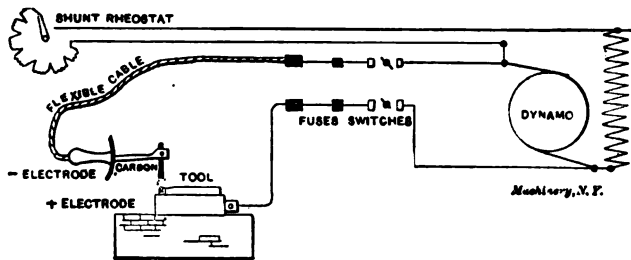

Fig. 4. Apparatus for Heating Tools by the Electric Arc.

Proceeding to harden the tool the action is as follows: The current is first switched on, and then the tool is gently lowered into the solution to such a depth as is required to harden it. The act of dipping the tool into the alkaline solution completes the electric circuit and at once sets up intense heat on the immersed part. When it is seen that the tool is sufficiently heated the current is instantly switched off, and the solution then serves to rapidly chill and harden the point of the tool, so that no air blast is necessary.

Another method of heating the point of tools is by means of the electric arc, the heating effect of which is also very rapid in its action. The general arrangement and form of the apparatus here employed is as illustrated in Fig. 4. The tool under treatment and the positive electrode are placed on a bed of non-conducting and non-combustible material and the arc started gradually at a low voltage and steadily increased as required, by controlling the shunt rheostat, care being taken not to obtain too great a heat and so fuse the end of the tool. The source of power in this case is a motor generator consisting of a continuous-current shunt-wound motor at 220 volts, coupled to a continuous-current shunt-wound dynamo at from 50 to 150 volts. Arcs

from 10 to 1,000 amperes are then easily produced and simply and safely controlled by means of the shunt rheostat.

#### Tempering.

Electricity is also a very efficient and accurate means of tempering such forms of tools as milling, gear, hobbing and other similar cutters, also large hollow taps, hollow reamers, and all other hollow tools made of high-speed steel, where it is required to have the outside or cutting portion hard, and the interior soft and tenacious, so as to be in the best condition to resist the great stresses put upon the tool by the resistance of the metal being cut, and which stresses tend to cause disruption of the cutter if the hardening extends too deep. By means of the apparatus illustrated in Fig. 5 this tempering or softening of the interior can be perfectly and quickly effected, thus bringing the cutter into the best possible condition to perform rapid and heavy work.

Tempering of hollow cutters, etc., is sometimes carried out by the insertion of a heated rod within the cutter and so drawing the temper,

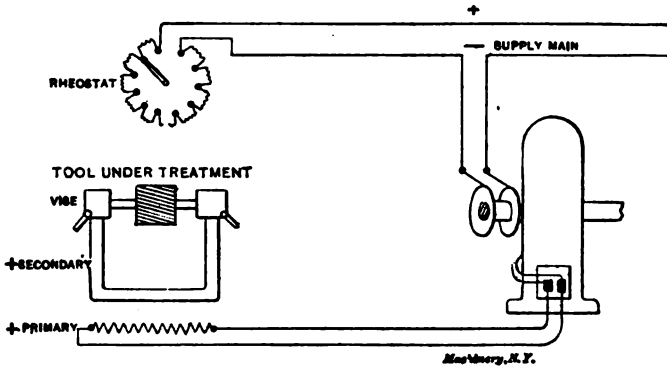

Fig. 5. Apparatus for Tempering Milling Cutters Electrically.

but this is not entirely satisfactory, or scientific, and is liable to induce cracking by too sudden heat application, and further because of the difficulty of maintaining the necessary heat and temperature required, and afterward gradually lowering the heat until the proper degree of temper has been obtained. In electrical tempering these difficulties are overcome, as the rod is placed inside the cutter quite cold, and the electric current gradually and steadily heats up the rod until the correct temperature is reached. Then it can be held at such temperature as long as is necessary, and the current can be gradually reduced until the articles operated on are cold again, and consequently the risk of cracking by too sudden expansion and contraction is reduced very greatly. The apparatus used is very simple, as will be seen by reference to Fig. 5. It consists of a continuous-current shunt-wound motor directly coupled to a single-phase alternating-current dynamo of the revolving field type giving 100 amperes at 350 volts, 50 cycles per second, the exciting current being taken from the works supply main. The power from the alternator is by means of a stepdown transformer,

reduced to current at a pressure of 2 volts, the secondary coil of the transformer consisting of a single turn of copper of heavy cross-section, the extremities of which are attached to heavy copper bars carrying the connecting vises holding the mandrel upon which the cutter to be tempered is placed. The secondary induced current, therefore, passes through a single turn coil, through the copper bars and vises and mandrel. Although the resistance of the complete circuit is very low, still, owing to the comparatively high specific resistance of the iron mandrel, the thermal effect of the current is used up in heating the mandrel which gradually attains the required temperature, slowly imparting its heat to the tool under treatment until the shade of the

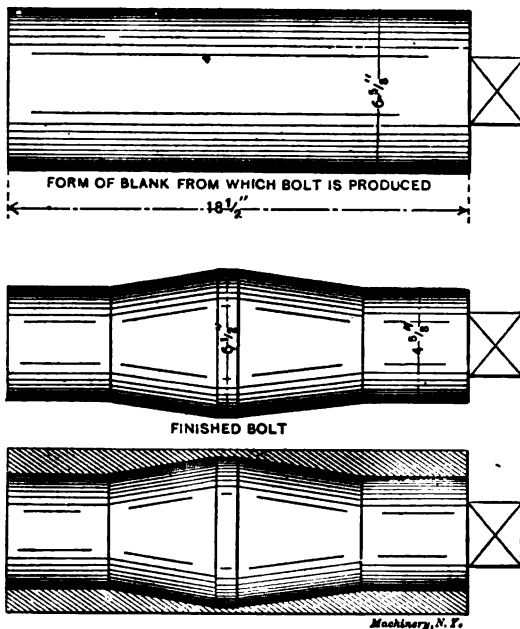

Fig. 6. Armor Bolt Turned at a Cutting Speed of 100 Feet per minute; Feed, 1-32 inch; Mean Depth of Cut, 3-4 inch.

oxide on the tool satisfies the operator. The method adopted to regulate the heat of the mandrel is by varying the excitation current of the alternator by means of the rheostat. An extremely fine variation and perfect heat control is easily possible by this arrangement.

#### Some Results of the Use of High-Speed Steel.

That great economy is effected by the use of high-speed steel is beyond all doubt, from whichever point of view the question is looked at; for it is not only rapidity of cutting that counts, but the output of machines is correspondingly increased, so that a greater production is obtained from a given installation than was possible when cutting at low speeds with the old tool steel, and the work is naturally produced

at a correspondingly lower cost, and of course it follows from this that that in laying down new plant and machines the introduction and use of high-speed steel would have considerable influence in reducing expenditure on capital account. It has also been proved that high-speed cutting is economical from a mechanical standpoint and that a given horse-power will remove a greater quantity of metal at a high speed than at a low speed, for although more power is naturally required to take off metal at a high than at a low speed (by reason of the increased

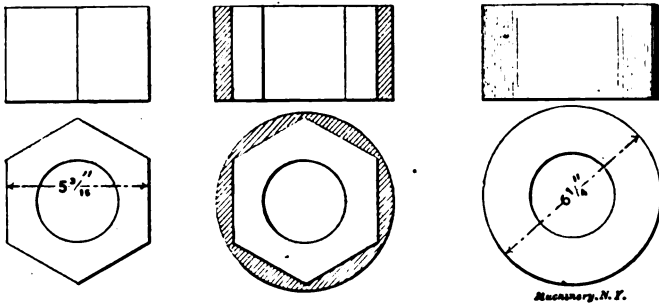

Fig. 7. Examples of Work Milled with a Cutting Speed of 150 Feet per Minute; Maximum Depth of Cut, 1 1-2 inch.

work done) the increase of that power is by no means in proportion to the large extra amount of work done by the high-speed cutting, for the frictional and other losses do not increase in anything like the same ratio as a high-cutting speed is to a low-cutting speed. A brief example of this may be given in which the power absorbed in the lathe was accurately measured, electrically.

Cutting on hard steel, with  $3/16$ -inch depth of cut,  $1/16$ -inch feed and speed of cutting 17 feet per minute, a power of 5.16 horse-power was

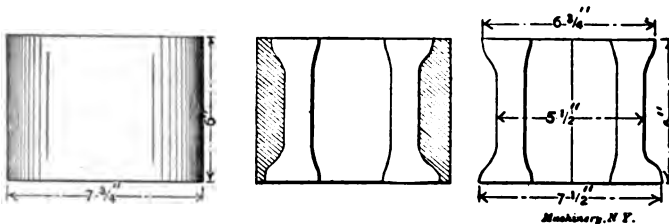

Fig. 8. Sleeves for Armor Bolts Turned with a Cutting Speed of 150 Feet per Minute; Feed,  $1/32$  inch; Maximum Depth of Cut,  $1 1/8$  inch.

absorbed, and increasing the cutting speed to 42 feet per minute, the depth of cut and feed being the same, there was a saving in power of 19 per cent for the work being done. Another experiment with depth of cut  $3/8$  inch and traverse  $1/16$  inch compared with  $1/16$  inch traverse and  $3/16$  inch depth of cut, showed a saving in power of as much as 28 per cent, and still proceeding with a view of increasing the weight of metal removed in a given time the feed was doubled (other conditions being the same) and a still further saving of power resulted.

In a word, as in the majority of things, so it is with rapid cutting, the more quickly work can be produced the cheaper the cost of production will be.

Again, as regards economy, there is not only a saving effected on the actual machine work, but since the advent of high-speed cutting it is now possible, in many instances, to produce finished articles from plain rolled bars, instead of following the old practice of first making expensive forgings and afterward finishing them in the machine. By this practice not only is the entire cost of forging abolished, but the machining on the rolled bar can be carried out much quicker and cheaper in suitably arranged machines, quicker even than the machining of a forging can be done.

A remarkable sample of the gain resulting from the use of high-



Fig. 9. Making Hexagon Nuts from Rolled Bars with Cutters made from High-Speed Steel. Ninety Nuts Produced in a Day of Ten Hours.

speed cutting from rolled bars is illustrated in Fig. 6, the articles in this case being securing-bolts, made by the author's firm, for armor plates. Formerly where forgings were first made and then machined with ordinary self-hardening steel, a production of eight bolts per day of ten hours was usual. With the introduction of high-speed steel, forty similar bolts from the rolled bar are now produced in the same time, thus giving an advantage of five to one in favor of quick cutting, and also in addition abolishing the cost of first rough forging the bolt to form; in fact, the cost of forging one bolt alone amounted to more than the present cost of producing to required form twelve such bolts by high-speed machining. The cutting speed at which these bolts are turned is 160 feet per minute, the depth of cut and feed being respectively  $3/4$  inch and  $1/32$  inch, the weight of metal removed from each

bolt being 62 pounds, or 2,480 pounds in a day of ten hours, the tool being only ground once during such period of work; from such an example as this it will be at once apparent what an enormous saving in plant and costs results. On the same principle the sleeves (see Fig. 8) of these bolts are produced from bars, sixty being made in one day of ten hours, this being even a greater saving on the old system than the bolt example shows.

Equally remarkable results are obtained by operating on stock bars with high-speed milling cutters, and one example among many, may be cited, which is shown in Fig. 7. Here hexagon nuts for  $3\frac{3}{8}$  inches diameter bolts are made from rolled bars, the cutting speed of milling being 150 feet per minute, giving a production of ninety nuts per day, against thirty formerly. More than ninety nuts could have been produced had the machine been more powerful.

## CHAPTER V.

### HARDENING STEEL.

Every shop has one or more men who are considered authorities on hardening. In many cases the man is really an expert, is careful, and uses good judgment in heating the steel and in quenching in the bath: and if the piece is of sufficient size, he is sure to take the strains out by reheating directly after taking from the bath. In some cases, however, the success of one operation is measured by the failure of others. Then if the work passes through the fiery ordeal with enough of it left intact to do the work it is considered a *successful operation*; if not, the fault *must* be in the steel. A manufacturing concern once changed the brand of tool steel they were using three times in less than a year, because the man doing the hardening reported adversely on each make, after attempting to harden it. The article furnished was from three of the leading makers of tool steel. After receiving repeated complaints in regard to the man's inability to harden the steel successfully, one of the makers advised the manufacturers to let some expert in hardening try the steel. Some milling machine cutters were made from each brand of the rejected article and sent to the steel makers. They all came back hard enough, without cracks, proving that the trouble was not in the steel.

#### Kind of Steel Used.

An expensive steel is not necessarily a satisfactory investment, and a "cheap" brand may be *very expensive*. It is necessary to understand just what is needed in a steel for a given purpose. Some makers have different grades of steel for different purposes—one for taps and similar tools, another for milling machine cutters, etc.—while others put out a steel that is very satisfactory for most purposes. Each has a good



argument in favor of his particular method of manufacture. In some shops it is thought advisable to use a grade of steel adapted to each individual class of tool; while in other shops, where detail is not followed as closely, this would cause no end of confusion. That part of the subject must be left to the judgment of the individual shop. But the treatment of the steel in the fire and the bath, in order to be successful, must be along certain lines. The successful hardener is he who finds out what particular quality is needed in the piece he is to harden; whether extreme hardness, toughness, elasticity, or a combination of two of these qualities. Then he must know the method to use in order to produce the desired result. The shape of the piece, the nature of the steel, the use to be made of the article, must all be taken into consideration. He must also be governed somewhat by the kind of fire he is to use.

#### Heating the Steel.

Some brands of steel will not stand, without injury, the range of heat that others will; some require more heat than others in order to harden at all. When hardening, no steel should be heated hotter than is necessary to produce the desired result. With some brands that give off their surface carbon very readily it is not advisable to heat them in an open fire, exposed to the action of the blast and outside air, as the products of combustion extract the carbon to such an extent that the surface will be soft even when the interior is extremely hard. While this might not materially affect a tool that is to be ground, it would spoil a tap, a formed cutter, or similar article, whose outside surface could not be removed. In hardening anything of this nature in an open fire, it should be placed in a piece of tube or some receptacle, so that the fire cannot come in contact with it while heating. There are a number of gas and gasoline hardening furnaces made which have a muffler to receive the work. The fire circulates around the muffler but does not come in contact with the steel. Very excellent results may be obtained when one of these furnaces is used. The front can be closed by means of a door, thus keeping all outside air away from the work. It will be found a great advantage if several large holes are drilled in the door, these being covered with isinglass, to enable the operator to see the work without opening the door.

Taking carbon from the steel is not the only injury done to a high grade of steel when heated in an ordinary blacksmith's forge by a careless operator. Most inexperienced men are apt to use a small fire, particularly if they find one ready built. It may be mostly burned out, but the operator will not care to take the time to get fresh coal, and get the fire to the proper heat; so he puts on the blast and endeavors to heat the work. After a time the piece has all kinds of heats, ranging from a low red to a white heat. The operator thinks it *averages* well, and dips it in the bath. If it comes out in one piece he is fortunate.

Heating in a small fire is dangerous business, as the work not only comes in contact with the surrounding air, but with the cold air from the blast, which will cause minute surface cracks, making the steel

look as though full of hairs. It will also fill the steel with "strains," causing ends of projections to crack and drop off in the bath.

If obliged to use the blacksmith's forge, use plenty of good charcoal. Make a large, high fire if the piece to be hardened is of any size; keep it up well from the blast inlet, using only blast enough to keep the fire lively, and bring the piece to the proper heat, burying it well in the fire to keep it from the air. The lowest heat that will give the desired result should be used. This varies in different makes of steel, and must also be varied somewhat according to size and shape of the work. The teeth of a milling machine cutter will harden at a lower heat than a solid piece of the same size made from the same bar. Most steelmakers in their instructions advise to harden at a low cherry red. To the average man this is a very uncertain degree; his cherries may be of a different hue from some other fellow's. Most of the leading brands of tool steel in small sizes, however, give the best results when hardened just after the black has disappeared from the center of the piece, provided we were heating slowly so as to get a uniform heat. In no case should steel be dipped when there is a trace of black in it.

The higher a piece of steel is heated—to a certain degree—the harder it will be; but if it is heated higher than to this degree the grain is opened, making it coarse and brittle, and it will be very liable to flake off under strain. For this reason, in the case of cutting tools, it is best to harden at as low a heat as possible. If the work gets too hot, yet not to a point where it is burned, it is always best to allow it to cool until the red has entirely disappeared, then reheat to the proper degree and harden, and the grain will be fine; but if allowed to cool to the proper hardening heat and dipped, it would be as coarse as if hardened at the high heat, and would also be very liable to crack.

#### Annealing.

In hardening, a great deal depends on the annealing. It is as necessary to understand how to anneal properly as it is to know how to harden right. As generally understood, the purpose of annealing is to soften the steel, which is all right, so far as the party is concerned who works it to shape; but its relation to hardening is another matter. It removes all strains in the steel, incident to rolling and hammering in the steel mill and forging in the blacksmith shop. Experience teaches the hardener that it is necessary to anneal any odd-shaped piece or one with a hole or impression in it, after it has been blocked out somewhere near to shape, a hole somewhat smaller than finished size being drilled in it, and all surface scale being removed. The most satisfactory method to pursue is to pack in an iron box with granulated charcoal, not allowing any of the pieces to come within one inch of the box at any point. This box should then be placed in the furnace and kept at a bright red heat for a length of time dependent on the size of the steel. Pieces one inch in diameter should be kept at a red heat for one hour after the box is heated through; larger pieces should be kept hot correspondingly longer, allowing the work to cool off as slowly as possible. An annealing heat should be higher than a heat for hardening the same piece. The proper heat for annealing, in order that

all strains may be overcome, should be nearly as high as for forging the same piece; in other words, the work should be heated to a bright red and kept so long enough to overcome any strain or tension liable to manifest itself when the piece is hardened. Tool steel for annealing should never be packed in cast-iron chips or dust, as this extracts the carbon to such an extent that there will be trouble when hardening is attempted. Packing too near the walls of the annealing box will have the same effect to a less extent, but will be more troublesome, as the carbon will be extracted from the surfaces nearest the box, and not affected anywhere else, making the hardening very uneven.

If not situated so that this method can be used, very satisfactory results may be obtained by heating in a large charcoal fire to a uniform forging heat. Put two or three inches of ashes in the bottom of an iron box; on this place a piece of soft wood board, put the work on it, cover with another piece of board, and fill the box with ashes. The boards will char and smolder, keeping the work hot for a long time. Some blacksmiths use a box of cold ashes, while others use cold lime; either way is liable to chill the piece, making it harder than if allowed to cool in the air, and if either material is used it should be hot to get good results. Excellent results may be obtained by heating in a muffle oven, as a very uniform heat of any degree may thus be obtained. It can be run any length of time, but when a piece is heated through in this way it takes a long time to cool.

#### Hardening Baths.

Hardening a piece of steel is generally accomplished by heating to a low red, and plunging in some cooling bath. As so much depends on the bath, it is quite necessary to understand the effects of the use of the different kinds. The one most commonly used is clear cold water, though many use salt and water or brine. For hardening small articles that must be extremely hard, the following will be found very satisfactory: One pound citric acid crystals dissolved in one gallon of water. For very thin articles a bath of oil is necessary. For hardening springs, sperm oil is very satisfactory; when hardening cutting tools, raw linseed oil is excellent. There are hundreds of formulas for hardening compounds, some of which are excellent for certain classes of work. Some hardening solutions are poisonous, and are dangerous to have around; but for ordinary work the ones mentioned are sufficient.

Many successful hardeners use water that has been boiled, claiming better results from its use than from fresh water. Small odd-shaped pieces are not so liable to crack nor to harden unevenly when the water is slightly warmed.

#### Examples of Hardening

We will now consider a few pieces of work to be hardened by the open-fire method. If we have a muffle furnace, so much the better, as with this it is easier to get certain results; but with care very satisfactory work can be done when the blacksmith forge is used. If it is a small tap, reamer, counterbore, or similar article we are to harden,

it is best to heat it in a tube, bring it to a low red, and plunge it in slightly warm water, or in the citric acid solution. If it is a hollow mill, with a hole running part way through it, we should dip it in the bath with the hole up, or the steam will keep the water from entering the hole, leaving the inside walls soft. The steam would also have a tendency to crack the piece; but with the hole up when dipping, by working the piece up and down well in the bath, the steam can escape, and the water can get at the work. Much bother may be saved the hardener if attention is paid to the steam likely to be generated, and some way provided to prevent its keeping the water from the work. Brine does not steam as readily as clear water; neither do the different acid solutions used by many.

In hardening a milling machine cutter, it is best to have a large high fire, to bury the cutter well in the fire, and to use only blast enough to bring the work to the required heat, which should be uniform throughout. If the piece has not been annealed after drilling a hole through it, remove it from the fire when red hot, then allow it to cool off slowly until the red has entirely disappeared, when it can be again placed in the fire and slowly brought to the required heat; it is then plunged in a bath of tepid water or brine and worked around well until it stops "singing." At this point it should be removed and instantly plunged in an oil bath, and left there until it is cool, when the strain should be removed by holding it over the fire until it is warm enough to snap when touched with the moistened finger. It can then be laid aside, and the temper drawn at leisure. In hardening punch press dies we can treat them the same; if there are any screw holes for stripper or guide screws they should be plugged with fire clay or graphite.

Metal slitting saws can be hardened nicely between iron plates whose surfaces are kept oiled. The saws should be heated in such a manner that the fire does not come in contact with them. It is best to heat on a flat plate, as the tendency to warp is much less than if laid on an uneven surface. When the saw is properly heated, place it on the lower oiled plate, placing the other one on it as quickly as possible; hold the upper plate down hard until the saw is cool. If there are many such pieces to harden, a fixture can be made so that one man can handle the saws and fixture alone; otherwise it requires two operators.

If there is no other means of drawing temper, the work may be brightened and drawn by color; but, if possible, do the drawing to temper in a kettle or crucible of oil over the fire, gaging the heat by a thermometer. Much more satisfactory results can be obtained by this latter method; and if very many pieces are to be done, it will be found much cheaper. A very light yellow is 430 degrees; a straw color is 460 degrees; a brown yellow, 500 degrees; a light purple, 530 degrees. A milling machine cutter for ordinary work should be drawn to 430 degrees; a punch press die to 500 degrees; the punch to 530 degrees, and metal-slitting saws to 530 degrees.

## CHAPTER VI.

### CASE-HARDENING.

The present chapter contains an abstract published in **MACHINERY**, August, 1905, of a paper read by Mr. David Flather before the Cycle Engineers' Institute, Birmingham, England.

The term "case-hardening" naturally implies the hardening of the skin of an article, and in order to fully understand the process and its object we must briefly consider the facts and laws upon which it is founded. Carbon has a very great affinity for iron and combines with it at all temperatures above faint red heat. Advantage is taken of this fact in the production of steel by cementation—in fact, the process of case-hardening is in reality incomplete cementation followed by water or oil hardening.

For many purposes in machine work we require articles to have a perfectly hard surface and yet be of such a nature that there is no chance of their breaking in use. In many instances this result can be obtained with high-class crucible steel, but for axles, cups, cones, and many similar parts, it is extremely difficult to obtain perfect hardness combined with great resistance to torsional, shearing, or bursting strains. For such purposes nothing can meet these requirements so fully as articles which have been case-hardened. The greatest risks in the employment of all steel often occur during its treatment by the consumer, and whether it be the finest cast steel or only common Bessemer, it is of first importance that it should be carefully and properly treated with a view to the work it has to do.

Both iron and mild steel have been employed as material for case-hardening; but this is the "steel age," and iron has long passed its day. The steel employed should be prepared, selected, and controlled from the beginning with the object of suiting it to its requirements. There are, of course, many points relating to its composition and treatment by the producer which can only be gained by long experience and by study of the requirements. Suffice it to say that the steel used should be low in carbon and capable of absorbing more carbon with great uniformity when heated under proper conditions; it should contain a minimum of deleterious impurities, and be perfectly sound and free from mechanical faults or weaknesses caused by overheating during the manufacturing processes.

#### The Case-Hardening Furnace and Muffles.

The furnace should be so constructed as to be capable of being raised to a full orange heat (1,830 degrees F.), and maintained at that heat with great regularity. It should be so constructed that neither the fuel nor the direct flame can come in contact with the charge. The flames should uniformly impinge on the sides and roof of the muffle

in such a manner as to raise them to a high temperature, thus heating the contents of the muffle by radiated and not by direct heat. A furnace designed on this principle not only gives the best result but is also most economical in the matter of fuel. The muffle chamber and flues must, of course, be constructed of firebrick, and the doors should fit closely and also be lined with firebrick. It is important that there should be a small peep-hole in the door, with a cover plate; a hole  $1\frac{1}{2}$  inch diameter is quite large enough. This latter is really a most important detail, as it provides against the need of opening the doors in order to judge the heat, and is indeed the most accurate means of estimating the temperature by the eye. The furnace must be fitted with a reliable damper plate or other effectual means of controlling the draft.

Fig. 10 shows a furnace which may be useful as a guide for the erection. The upper chamber in this furnace is not necessary for case-hardening, but it may be found useful to have such a chamber and employ it for annealing small articles while case-hardening is being done. This will add only very slightly to the amount of fuel used.

Hardening pots are made in both cast and wrought iron, the former being cheaper in first cost, but the latter bear reheating so many times that they are cheaper in the end. The pots should not be of too large dimensions, or there is great risk of articles in the middle of a charge not being carbonized to a sufficient depth. No pot should be above 18 by 12 by 11 inches for such parts as cycle axles, pedal pins, and the like; while for small articles like cups, cones, etc., 12 by 10 by 8 inches is large enough. The pots should each have a plate-lid fitting closely inside.

The carbonizers in general use at the present day are animal charcoal, bones, and one or two other compositions sold under various names, consisting of mixtures of carbonaceous matter and certain cyanides or nitrates. For very slight hardening, cyanides alone are still found very useful, but no great depth of casing is ever attempted with these. Theoretically, the perfect carbonizer should be a simple and pure form of carbon, and good charred leather gives the most certain and satisfactory results. Care should be taken to avoid poorly charred leather or that made from old boots, belting, etc.

#### Clay.

As clay must be used for a luting around the pot lid, and is also frequently used for stopping off portions to be left soft, it is important to see that a good clay is used, and that it is free from grease. Clay contaminated with grease in any way will cause irregularity in the product.

#### Reheating Muffles.

As all case-hardened articles have to be reheated before quenching, it is important that a suitable furnace should be employed for the purpose. It is not advisable that the reheating should be done in the case-hardening muffle, unless it is run specially for the purpose and

at a lower heat. If possible a small gas muffle should be used for reheating, and indeed for all hardening work. A properly-constructed gas muffle can be regulated with great exactness, and this is very important in all hardening.

**Packing the Muffles.**

The carbonizer having been thoroughly dried and reduced to a fine powder, a layer of not less than  $1\frac{1}{2}$  inch in depth is placed in the

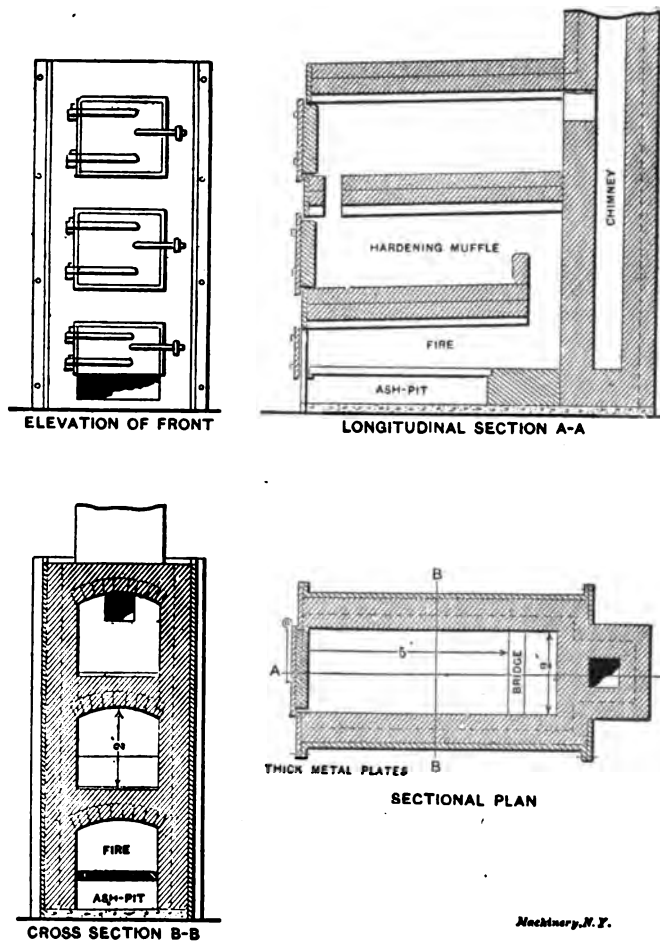

*Noelchery, N. Y.*

**Fig. 10. Plan and Elevation of Flather Case-hardening Furnace.**

hardening pot and well pressed down. Upon this are placed the articles to be hardened. Care must be taken to leave sufficient space all around each piece to prevent its touching the others or the walls of the pot; a space of  $1\frac{1}{2}$  inch should be sufficient. Another layer of carbonizer is then put in and well pressed down, taking care not to dis-

place any of the articles already packed, continuing until the pot is nearly full, and then finishing off with another layer of  $1\frac{1}{2}$  inch at the top. The object in view must be to make the contents of the pot as compact as possible, consistent with a sufficiency of carbonizer in contact with the articles. The more solidly a pot is packed the more complete is the exclusion of air. The lid is then put on, and the joint all around well luted with clay. By the time the proper number of pots have been filled, the furnace must have been raised steadily to the full working heat.

#### Furnace Heat.

The proper heat for case-hardening is about 1,800 degrees F., or a full orange heat and this should be maintained with great regularity throughout the operation. The length of time occupied in carbonizing is regulated by the depth of casing required, and indirectly by the dimensions of the article. At the close of the carbonizing period the pot is withdrawn from the furnace and placed in a dry place, where it is allowed to become quite cold. It is then opened, the articles taken out and brushed over to remove all adhering matter. If the pot has been properly packed, and luted up, the articles should be quite white, or at least have only a slight film or bloom of a deep blue color; the denser and more inclined to redness is the surface, the more imperfect has been the packing and sealing of the pot.

#### Reheating and Hardening.

The carbonized articles are now placed in a muffle furnace and steadily raised to a good cherry red (1,470 degrees F.), and then quenched in cold or tepid water or oil, according to the purpose of the articles required. They should remain in the cooling liquid until they are quite cold right through the body of the metal, thus completing the process.

Although the proper temperature for case-hardening is about 1,830 degrees F., this temperature may be modified to suit the purpose in view. The absorption of the carbon commences when the steel reaches a low cherry-red heat (1,300 degrees F.); it begins, of course, at the outer surface and gradually spreads until the whole of the steel is carbonized. The length of time this requires depends upon the thickness of the metal being treated. The percentage of carbon absorbed is governed by the temperature, and although the increase of carbon is not in uniform proportion to the rising temperature throughout, it is perhaps sufficient for our present purpose to note that at 1,300 degrees F., iron, if completely saturated, can contain no more than about 0.50 per cent carbon; at 1,650 degrees F., about 1.5 per cent carbon; and at 2,000 degrees F., about 2.5 per cent. These results, however, are only obtainable when the whole section of the iron has received all the carbon it is capable of absorbing at the given temperature, and is therefore in a state of equilibrium. From this it will be seen that if the process is stopped before the action is complete, the central parts of the iron must contain less carbon than the outside, and upon this fact the process of casehardening is founded.



If we take two pieces of  $\frac{5}{8}$  inch diameter round mild steel, and heat one of them with a carbonizer at a cherry-red heat, and the other at a bright orange heat, for six hours, the first will be cased to a depth of about 1-32 inch, and the other to a depth of nearly 1-16 inch, while the amount of carbon taken up will be about 0.50 and 0.80 per cent respectively. So that, so far as regards the hardness of the skin, the piece carbonized at the higher temperature gives the best result. From this we learn that a temperature of 1,830 degrees F. will give us sufficient hardness of case.

We have next to find which temperature has the least harmful effect on the mild steel core, and this can best be found by heating pieces of the mild steel at varying temperatures at and above the selected one for the same length of time, using lime or other inert substance in the pot instead of a carbonizing material, and afterward reheating and quenching in water. Suppose, for example, we take three pieces, heating at 1,830, 2,370 and 2,730 degrees F., or full orange, white and bright white respectively. We shall find that those at 2,370 and 2,730 degrees break very short and have lost nearly all their original tenacity, while that at 1,830 degrees appears tougher and altogether stronger than before.

Having arrived at a knowledge of the right temperature, it remains now to inquire as to the length of time requisite to yield a sufficient depth of case. At a full orange heat a bracket cup of ordinary dimensions should in two hours be hardened 1-32 inch deep, and a bracket axle 11-16 inch diameter in 6 hours would have a case 1-16 inch deep. From this it will be seen that the speed of penetration is not in exact proportion to the time of heating.

#### Results of Hardening Without Reheating.

We now arrive at that part of the process where a most important improvement has been made—*i. e.*, the final hardening by quenching in water. It formerly was customary at the end of the carbonizing period to open the pot and fling the contents headlong into a tank of cold water. Here and there some of the more careful workers took each article separately, but direct from the pot, and plunged it into water. These latter obtained better results, but even they had a great deal of trouble in the way of breakages and want of regular hardness. Finding that axles taken singly from the pot and quenched were better than those quenched in bulk, and that if allowed to cool down to cherry red they were better still, an application of the old rule to harden on a rising heat led to the now established principle of allowing the pot and its contents to become quite cold, afterward reheating to cherry red and quenching with water. By this means we obtain a case of great hardness with a very tough core—that is, of course, provided a suitable steel is employed.

To understand the reason of this improved method of working we must remember that the exterior of the steel is now of about 0.80 per cent carbon, and that steel of all kinds raised to and maintained at the high temperature employed for case-hardening will, unless subjected

to mechanical work, show evidence of overheating, being very brittle and liable to easy fracture; and though quenched in water, and consequently hardened, the metal has little or no cohesion and readily wears away. Steel so hardened breaks with a very coarse crystalline fracture, in which the limits of the case are badly defined. It is known that when steel is gradually heated there is a certain point at which a great molecular change takes place, and that perfect hardness can only be obtained by quenching at this critical point. If quenching takes place below the critical temperature, the steel is not sufficiently hard; if above, though full hardness may be obtained, strength and tenacity are lost in part or completely, according as the critical temperature is exceeded by much or by little. This critical point lies between 1,380 and 1,470 degrees F., or cherry-red color heat. It may be asked why it is not sufficient, when taking the article out of the pot, to allow it to cool down to cherry red and then quench it. To this the answer is that the high temperature has already created a coarsely crystalline condition in the steel, and that until it has become quite cold and has again been heated up to the critical temperature, a suitable molecular condition cannot be obtained. When steel is cooled, whether slowly or not, it bears in its structure a condition representative of the highest heat it was last subjected to. From this it will be quite clear that in case-hardening, as in all other methods of hardening, steel must be quenched on a rising heat.

## CHAPTER VII.

### THE BRINELL METHOD OF TESTING THE HARDNESS OF METALS.

The method of testing the hardness of metals devised by Mr. J. A. Brinell has received very favorable attention from metallurgists in this, as well as in other countries. In 1900 Mr. Brinell, then chief engineer and technical manager of the Fagersta Iron and Steel Works in Sweden, first made public his method of testing the hardness of iron and steel, by submitting it to the Society of Swedish Engineers in Stockholm. At the meeting of the *Congrès International des Méthodes d'Essai des Matériaux de Construction* in Paris the same year the method attracted general attention, and its merits were duly acknowledged by awarding the inventor with a personal *Grand Prix* at the Paris Exposition. The method was first described in the English language by Mr. Axel Wahlberg in a paper before the Iron and Steel Institute in 1901. Since then, the practical value of this method has been amply substantiated on various occasions by means of comprehensive tests and investigations undertaken by several distinguished scientists in different countries. In working out his method, Brinell kept in view the necessity of taking into account the requirements that the method must be trustworthy, must be easy to learn and apply, and capable of being used on almost any piece of metal, and particularly, to be used on metal without in any way being destructive to the sample.

#### Principle of Method for Testing Hardness of Metals.

The Brinell method consists in partly forcing a hardened steel ball into the sample to be tested so as to effect a slight spherical impression, the dimensions of which will then serve as a basis for ascertaining the hardness of the metal. The diameter of the impression is measured, and the spherical area of the concavity calculated. On dividing the amount of pressure required in kilogrammes for effecting the impression by the area of the impression in square millimeters an expression for the hardness of the material tested is obtained, this expression or number being called the *hardness numeral*. In order to render the results thus obtained by different tests directly comparable with one another, there has been adopted a common standard as well with regard to the size of ball as to the amount of loading. The standard diameter of the ball is 10 millimeters (0.3937 inch) and the pressure 3,000 kilogrammes (6,614 pounds) in the case of iron and steel, while in the case of softer metals a pressure of 500 kilogrammes (1,102 pounds) is used. Any variation either in the size of the ball or the amount of loading will be apt to occasion more or less confusion without there being any advantage to compensate for such inconvenience. Besides, making any comparisons between results thus obtained

in a different manner would be more or less troublesome, and complicated calculations would be required.

The diameter of the impression is measured by means of a microscope of suitable construction, and the hardness numeral may be obtained without calculation directly from the table given herewith, worked out for the standard diameter of ball and pressures mentioned. The formulas employed in the calculation of this table are as follows:

$$y = 2\pi r (r - \sqrt{r^2 - R^2}) \quad (1)$$

$$H = \frac{K}{y} \quad (2)$$

in which formulas

$r$  = radius of ball in millimeters,

$R$  = radius of depression in millimeters,

$y$  = superficial area of depression in square millimeters,

$K$  = pressure on ball in kilogrammes,

$H$  = hardness numeral.

Suppose, for instance, that the radius of the ball equals 5 millimeters (0.1968 inch), and that the test is undertaken on a piece of steel, the pressure consequently applied being 3,000 kilogrammes (6,614 pounds). Assuming that we found the radius of the depression equal to 2 millimeters (0.07874 inch) by measurement, we have:

$$2\pi \times 5 (5 - \sqrt{25 - 4}) = 13.13 = y,$$

and

$$\frac{3,000}{13.13} = 228 = H,$$

which as we see agrees with the figure given in our table for a 4 millimeters diameter of impression.

#### Relation Between Hardness of Materials and Ultimate Strength.

It has been pointed out by Mr. Brinell himself that this method of testing hardness of metals offers a most ready and convenient means of ascertaining within close limits the ultimate strength of iron and steel. This, in fact, is one of the most interesting and important results of this method of measuring hardness. In order to determine the ultimate strength of iron and steel, it is only necessary to establish a constant coefficient determined by experiments which serves as a factor by which the hardness numerals are multiplied, the product being the ultimate strength. Rather comprehensive experiments were undertaken with a considerable number of specimens of annealed material obtained from various steel works for the purpose of establishing the coefficient by the present director of the Office for Testing Materials of the Royal Technical Institution at Stockholm. The results obtained were as follows:

For hardness numerals below 175, when the impression is effected transversely to the rolling direction, the coefficient equals 0.362; when the impression is effected in the rolling direction, the coefficient equals 0.354.

For hardness numerals above 175, when the impression is effected

TABLE OF HARDNESS NUMERALS.  
Steel ball of 10 millimeters diameter.

| Diameter of Impression, mm. | Hardness Numeral, Pressure, kg. |     | Diameter of Impression, mm. | Hardness Numeral, Pressure, kg. |     | Diameter of Impression, mm. | Hardness Numeral, Pressure, kg. |      | Diameter of Impression, mm. | Hardness Numeral, Pressure, kg. |      |
|-----------------------------|---------------------------------|-----|-----------------------------|---------------------------------|-----|-----------------------------|---------------------------------|------|-----------------------------|---------------------------------|------|
|                             | 3000                            | 500 |                             | 3000                            | 500 |                             | 3000                            | 500  |                             | 3000                            | 500  |
| 2.00                        | 946                             | 159 | 3.00                        | 418                             | 70  | 4.00                        | 238                             | 38   | 5.00                        | 148                             | 28.8 |
| 2.05                        | 898                             | 150 | 3.05                        | 402                             | 67  | 4.05                        | 233                             | 37   | 5.05                        | 140                             | 28.8 |
| 2.10                        | 857                             | 148 | 3.10                        | 387                             | 65  | 4.10                        | 317                             | 86   | 5.10                        | 187                             | 22.8 |
| 2.15                        | 817                             | 136 | 3.15                        | 375                             | 63  | 4.15                        | 313                             | 85   | 5.15                        | 184                             | 23.8 |
| 2.20                        | 782                             | 130 | 3.20                        | 364                             | 61  | 4.20                        | 307                             | 84.5 | 5.20                        | 181                             | 21.8 |
| 2.25                        | 744                             | 124 | 3.25                        | 351                             | 59  | 4.25                        | 303                             | 83.6 | 5.25                        | 188                             | 21.5 |
| 2.30                        | 718                             | 119 | 3.30                        | 340                             | 57  | 4.30                        | 196                             | 82.6 | 5.30                        | 186                             | 21   |
| 2.35                        | 683                             | 114 | 3.35                        | 332                             | 55  | 4.35                        | 192                             | 82   | 5.35                        | 184                             | 20.6 |
| 2.40                        | 652                             | 109 | 3.40                        | 321                             | 54  | 4.40                        | 187                             | 81.2 | 5.40                        | 181                             | 20.1 |
| 2.45                        | 627                             | 105 | 3.45                        | 311                             | 52  | 4.45                        | 183                             | 80.4 | 5.45                        | 118                             | 19.7 |
| 2.50                        | 600                             | 100 | 3.50                        | 303                             | 50  | 4.50                        | 179                             | 29.7 | 5.50                        | 116                             | 19.8 |
| 2.55                        | 578                             | 96  | 3.55                        | 293                             | 49  | 4.55                        | 174                             | 29.1 | 5.55                        | 114                             | 19   |
| 2.60                        | 555                             | 93  | 3.60                        | 286                             | 48  | 4.60                        | 170                             | 28.4 | 5.60                        | 113                             | 18.6 |
| 2.65                        | 532                             | 89  | 3.65                        | 277                             | 46  | 4.65                        | 166                             | 27.8 | 5.65                        | 109                             | 18.2 |
| 2.70                        | 513                             | 86  | 3.70                        | 269                             | 45  | 4.70                        | 163                             | 27.2 | 5.70                        | 107                             | 17.8 |
| 2.75                        | 495                             | 83  | 3.75                        | 263                             | 44  | 4.75                        | 159                             | 26.5 | 5.75                        | 106                             | 17.5 |
| 2.80                        | 477                             | 80  | 3.80                        | 255                             | 43  | 4.80                        | 156                             | 25.9 | 5.80                        | 105                             | 17.2 |
| 2.85                        | 460                             | 77  | 3.85                        | 248                             | 41  | 4.85                        | 153                             | 25.4 | 5.85                        | 101                             | 16.9 |
| 2.90                        | 444                             | 74  | 3.90                        | 241                             | 40  | 4.90                        | 149                             | 24.9 | 5.90                        | 99                              | 16.6 |
| 2.95                        | 430                             | 73  | 3.95                        | 235                             | 39  | 4.95                        | 146                             | 24.4 | 5.95                        | 97                              | 16.2 |

,36 x 170 = 61.2  
 ,33 x 142.3 = 47.0

transversely to the rolling direction, the coefficient equals 0.344; when the impression is effected in the rolling direction, the coefficient equals 0.324.

If the hardness numerals are multiplied by these coefficients, the result obtained will be the ultimate tensile strength of the material in kilogrammes per square millimeter. It is evident that coefficients can easily be worked out so that if the hardness numerals be multiplied by these the strength could be obtained in pounds per square inch.

Suppose, for instance, that a test of annealed steel by means of the Brinell ball test gave an impression of a diameter of 4.6 millimeters. Then the hardness numeral, according to our table, would be 170, and the ultimate tensile strength consequently  $0.362 \times 170 = 61.5$

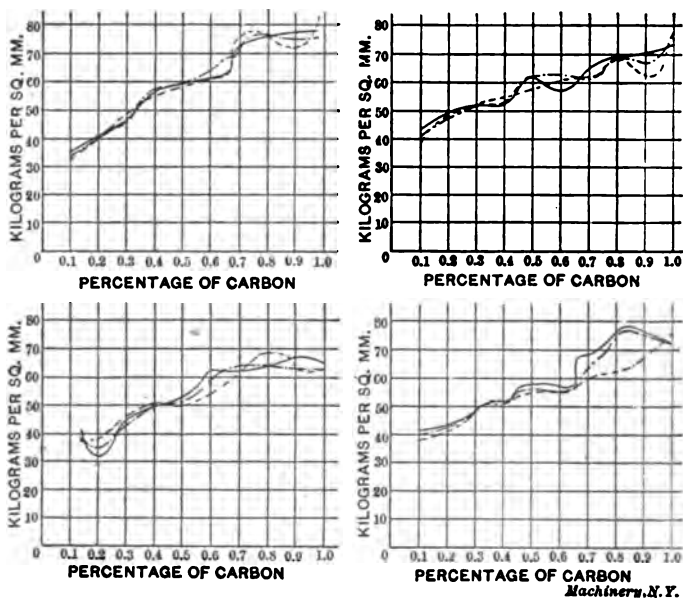

Fig. 11. Diagrams Showing Relation Between Results Obtained by Various Methods for Ascertaining the Ultimate Strength of Materials.

kilogrammes per square millimeter, provided the impression was effected transversely to the rolling direction.

In Fig. 11 are shown a number of diagrams which indicate the results obtained at the tests undertaken to ascertain the coefficients given. In these diagrams the full heavy line indicates the tensile strength of the material, as calculated from the ball tests in the rolling direction. The dotted lines indicate the strength as calculated from the ball tests in a transversal direction, and the "dash-dotted" lines show the actual tensile strength of the material as ascertained by ordinary methods for ascertaining this value. It is interesting to note how closely the three curves agree with one another, and considering

the general uncertainty and variation met with when testing the same kind of material for tensile strength by the ordinary methods, it is safe to say that the ball test method comes nearly as close to the actual results as does any other method used. Especially within the range of the lower rates of carbon, or up to 0.5 per cent, or in other words, within the range of all ordinary construction materials, the coincidents are, in fact, so very nearly perfect as to be amply sufficient to satisfy all practical requirements.

In the case of any steel, whether it be annealed or not, that has been submitted to some further treatment of any other kind than annealing, such as cold working, etc., or in the case of any special steel, there would be other coefficients needed which would then also be ascertained by experiments. The same coefficient, however, will hold true for the same kind of material having been subjected to the same treatment. Thus, the ball testing method for strength is equally satisfactory, and far more convenient, in all cases where the rupture test would be applied. One of the greatest advantages of the Brinell method is that in the case of a large number of objects being required to be tested, each one of the objects can be tested without demolition, and without the trouble of preparing test bars.

#### **Application of the Brinell Ball Test Method.**

Summarizing what has been said in the previous discussion, and adding some other important points, we may state the various uses for which the Brinell ball test method may be applied, outside of the direct test of the hardness of construction materials and the calculation from this test of the ultimate strength of the materials, as follows:

1. Determining the carbon content in iron and steel.
2. Examining various manufactured goods and objects, such as rails, tires, projectiles, armor plates, guns, gun barrels, structural materials, etc., without damage to the object tested.
3. Ascertaining the quality of the material in finished pieces and fragments of machinery even in such cases when no specimen bars are obtainable for undertaking ordinary tensile tests.
4. Ascertaining the effects of annealing and hardening of steel.
5. Ascertaining the homogeneity of hardening in any manufactured articles of hardened steel.
6. Ascertaining the hardening power of various quenching liquids, and the influence of temperature of such liquids on the hardening results.
7. Ascertaining the effect of cold working on various materials.

#### **Machines used for Testing the Hardness of Metals by the Brinell Method.**

The method of applying the Brinell ball test was at first only possible in such establishments where a tensile testing machine was installed. As these machines are rather expensive, the use of the ball test method was limited. For this reason a Swedish firm, Aktiebolaget Alpha, Stockholm, Sweden, has designed and placed on the market a

compact machine specially intended for making hardness tests. This machine, as shown in Fig. 12, consists of a hydraulic press acting downward, the lower part of the piston being fitted with a 10-millimeter steel ball *k* by means of which the impression is to be effected in the surface of the specimen or object to be tested. This object is placed on the support *s* which is vertically adjustable by means of the

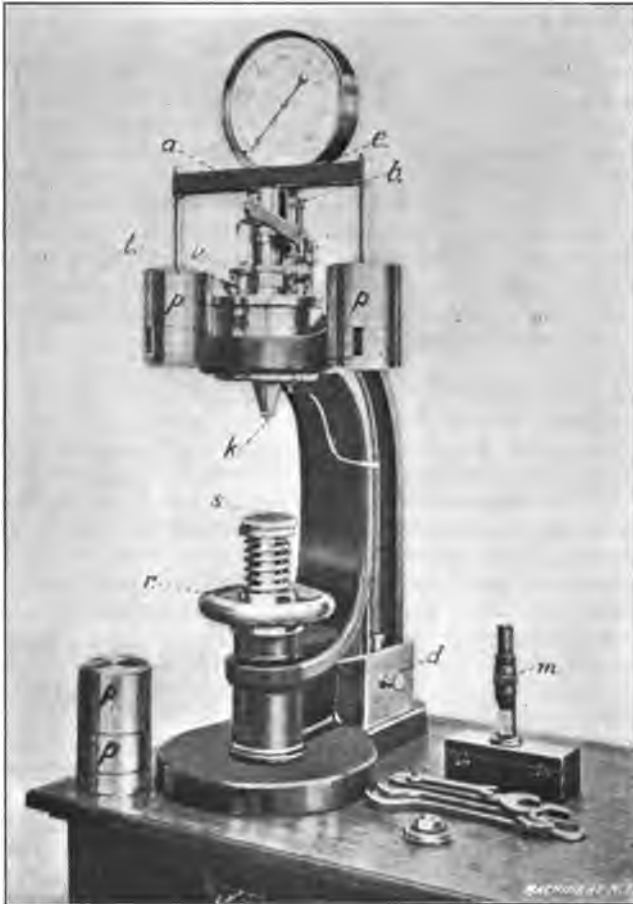

Fig. 12. Aktiebolaget Alpha's Machine for Testing Hardness of Materials.

hand-wheel *r*, while at the same time it can be inclined sideways when this is needed on account of the irregular shape of the part tested. The whole apparatus is solidly mounted on a cast iron stand. The pressure is effected by means of a small hand pump, and the amount of pressure can be read off directly in kilogrammes on the pressure gage mounted at the top of the machine.

In order to insure against any eventual non-working of the mano-



meter, this machine is fitted with a special contrivance purporting to control in a most infallible manner the indications of that apparatus, while at the same time serving to prevent any excess of pressure beyond the exact amount needed according to the case. This controlling apparatus consists of a smaller cylinder, *a*, directly communicating with the press-cylinder. On being loaded with weights corresponding to the amount of pressure required, the piston in this cylinder will

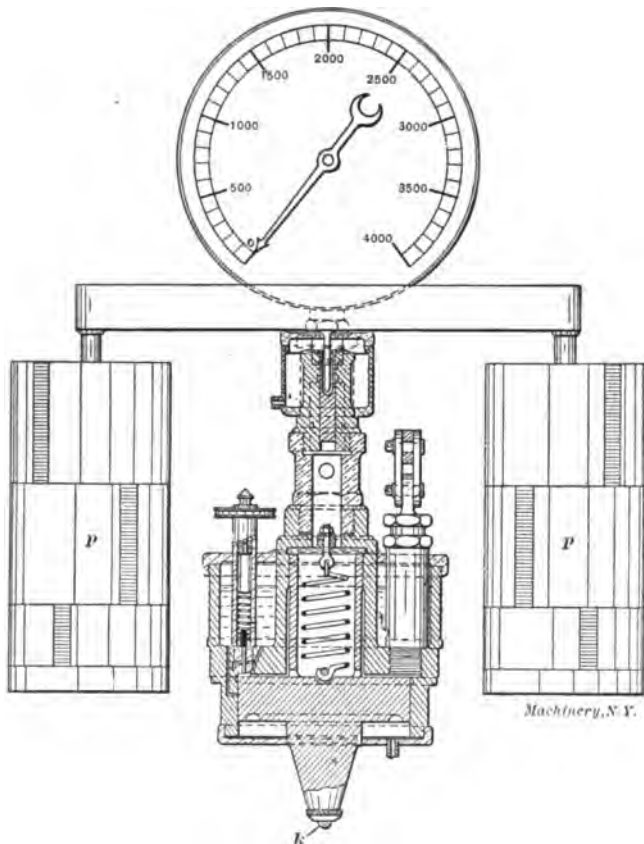

Fig. 13. Section of Press Cylinder of Machine in Fig. 12.

be pushed upward by the pressure effected within the press-cylinder at the very moment when the requisite testing pressure is attained. Owing to this additional device, there can thus be no question whatever of any mistake or any errors as to the testing results, that might eventually be due to the manometer getting out of order.

#### Method of Performing the Ball Test.

The test specimen must be perfectly plane on the very spot where the impression is to be made. It is then placed on the support *s*, Fig.

12, which, as mentioned, is adjusted by means of the hand-wheel *r* so as to come into contact with the ball *k*. A few slow strokes of the hand pump will then cause the pressure needed to force the ball downward, and a slight impression will be obtained in the object tested, but as soon as the requisite amount of pressure has been attained, the upper piston is pushed with the controlling apparatus upward, as previously described. On testing specimens of iron and steel, the pressure is maintained on the specimen for 15 seconds, but in the case of softer materials for at least half a minute. After the elapse of this time, the pressure is released, and the contact between the ball and the sample will cease. A spiral spring fitted within the cylinder, and being just of sufficient strength to overcome the weight of the press piston, pulls the same upward into its former position, while forcing the liquid back into its cistern. The diameter of the impression effected by the ball is then measured by the microscope *m*, which is specially constructed for this purpose, the results obtained by this measurement being exact within 0.05 millimeter (0.002 inch). Fig. 13 shows a cross-section through the cylinder and piston part of the machine. Another type of machine is designed for special tests in which very high pressures are required. The ball in this machine is 19 millimeters (0.748 inch) in diameter, and the pressures employed vary from 3 to 50 tons. The construction and operation are otherwise exactly the same as that of the smaller machine in Fig. 12.

No. 10. **EXAMPLES OF MACHINE SHOP PRACTICE.**—Cutting Bevel Gears with Rotary Cutters; Making a Worm-Gear; Spindle Construction.

No. 11. **BEARINGS.**—Design of Bearings; Causes of Hot Bearings; Alloys for Bearings; Ball Bearings; Friction of Roller Bearings.

No. 12. **MATHEMATICS OF MACHINE DESIGN.**—Compiled with special reference to shafting and efficiency of hoisting machinery.

No. 13. **BLANKING DIES.**—Making Blanking Dies; Blanking and Piercing Dies; Construction of Split Dies; Novel Ideas in Die Making.

No. 14. **DETAILS OF MACHINE TOOL DESIGN.**—Cone Pulleys and Belts; Strength of Countershafts; Tumbler Gear Design; Faults of Iron Castings.

No. 15. **SPUR GEARING.**—First Principles of Gearing; Formulas for Spur Gearing; Design and Calculation of Gear Wheels; Strength of Gear Teeth.

No. 16. **MACHINE TOOL DRIVES.**—Speeds and Feeds of Machine Tools; Geared or Single Pulley Drives; Drives for High Speed Cutting Tools.

No. 17. **STRENGTH OF CYLINDERS.**—Formulas, Charts, and Diagrams for Thick Hollow Cylinders; Design of Thick Cylinders; Cast Iron Cylinders.

No. 18. **SHOP ARITHMETIC FOR THE MACHINIST.**—Figuring Tapers, Change Gears, Cutting Speeds and Feeds, Indexing Movements, etc.; Use of Formulas; Square and Square Root; Use of Tables of Sines and Tangents.

No. 19. **USE OF FORMULAS IN MECHANICS.**—Mathematical Signs and Formulas; Strength of Materials; Graphical Methods; Levers; Center of Gravity.

No. 20. **SPIRAL GEARING.**—Calculating Spiral Gears; Rules, Formulas, and Diagrams for Designing Spiral Gears; Efficiency of Spiral Gearing, etc.

No. 21. **MEASURING TOOLS.**—History and Development of Standard Measurements; Special Calipers, Compasses, Micrometer Measuring Tools, Protractors, etc.

No. 22. **CALCULATION OF ELEMENTS OF MACHINE DESIGN.**—Factor of Safety; Strength of Bolts; Riveted Joints; Keys and Keyways; Toggle-joints.

No. 23. **THEORY OF CRANE DESIGN.**—Jib Cranes; Calculation of Shaft, Gears, and Bearings; Force Required to Move Crane Trolleys, etc.

No. 24. **EXAMPLES OF CALCULATING DESIGNS.**—Charts in Designing; Punch and Riveter Frames; Shear Frames; Billet and Bar Passes; etc.

No. 25. **DEEP HOLE DRILLING.**—No. 26. **MODERN PUNCH AND DIE CONSTRUCTION.**—No. 27. **LOCOMOTIVE DESIGN, Part I, Boiler and Cylinders.**—No. 28. **LOCOMOTIVE DESIGN, Part II, Valve Motion.**—No. 29. **LOCOMOTIVE DESIGN, Part III, Smokebox, Frames, and Driving Machinery.**—No. 30. **LOCOMOTIVE DESIGN, Part IV, Springs, Trucks, Cab and Tender.**—No. 31. **SCREW THREAD TOOLS AND GAGES.**—No. 32. **SCREW THREAD CUTTING.**—No. 33. **SYSTEMS AND PRACTICE OF THE DRAFTING-ROOM.**—No. 34. **CARE AND REPAIR OF DYNAMOS AND MOTORS.**—No. 35. **TABLES AND FORMULAS FOR SHOP AND DRAFTING-ROOM.**—No. 36. **IRON AND STEEL.**—No. 37. **BEVEL GEARING.**—No. 38. **GRINDING AND LAPPING.**—No. 39. **FANS, VENTILATION AND HEATING.**—No. 40. **FLY-WHEELS.**

The foregoing books, up to and including No. 26, were published and in stock in November, 1908. The remainder will go to press as rapidly as practicable. The complete plan of the series, as stated, is to cover the whole field of mechanical practice, and the editors are preparing the additional titles, which will, from time to time, be announced in MACHINERY.

The Industrial Press, Publishers of MACHINERY,

49-55 Lafayette Street

Worth Street  
Subway Station

New York City, U.S.A.

