

MACGILLIBRY'S
REFERENCE SERIES

No. 2.

DRAFTING ROOM
PRACTICE

LIBRARY EDITION

621.75
D78
RC

MACHINERY'S REFERENCE SERIES

EACH NUMBER IS ONE UNIT IN A COMPLETE
LIBRARY OF MACHINE DESIGN AND SHOP
PRACTICE REVISED AND REPUB-
LISHED FROM MACHINERY

NUMBER 2

DRAFTING-ROOM PRACTICE

SECOND EDITION

CONTENTS

Drafting-Room System, by RALPH E. FLANDERS	- -	3
Tracing, Lettering and Mounting, by I. G. BAYLEY	-	17
Card Index Systems, by A. L. VALENTINE, J. S. WATTS and A. B. HOWK	- - - - -	34



CHAPTER I

DRAFTING-ROOM SYSTEM*

The drafting-room may be said to bear a double relation to the shop. It is the place where designs are originated, and so in a sense it is the head of the shop, furnishing it with the ideas which the machinist turns into concrete forms in iron and steel. On the other hand, the drafting-room may be the servant of the rest of the establishment, doing its calculating and its routine work of testing, etc., lessening the tax on the memory, and leaving the minds of the workmen and foremen free to the task of getting out the product. In different shops, the use which is made of these two functions varies—one or the other of them may be neglected. It is safe to say, however, that there are scores of shops where the drafting-room is looked upon as an almost unnecessary evil, and every cent which is spent in its salaries and supplies begrudged, when this part of the plant might be the servant of the whole, making the work go more smoothly and easily all along the line, from office to shipping-room, if the men in charge understood how to get from it its full value. It is this second function which is, perhaps, least understood. In the following, attention will be called to some of the different ways in which the drafting-room may lighten the labors of the workmen, lessen the strain on the foreman, and grease the wheels of industry generally. We will neglect entirely the matter of design, therefore, and consider the routine office work of a typical shop. All the ideas which will follow have been put into practical and satisfactory use, some of them for years in the largest establishments in the country.

Systems will vary greatly in such widely varying lines as fire-arms, electrical apparatus and milling machines, but in order to take a case which will be most suggestive, suppose it is required to equip with all necessary drawings, lists and records, a small shop building a line of machine tools.

Numbering the Parts

We should have to start with a layout of the machine in hand, done to accurate scale, made either as a new design or a copy of a machine already being produced. The first question to consider is that of numbering the parts and arranging the detail drawings. A good way to number the parts, drawings, etc., is to give to each variety of tool produced a distinctive letter, such as "A" for universal, "B" for plain, and "C" for vertical milling machines, "D" for shaper, and so on. Attached to this is a number distinguishing the size. "B2" is No. 2 plain miller, "L24" might be 24-inch lathe, and so on. The men in the shop and office alike soon fall into the way of calling the machines

* MACHINERY, March, 1905.

by these nicknames. Then each separate part is given a serial number. Thus "L20-49" might mean the head cone gear for a 20-inch lathe. This designation would be marked on the pattern and serve as a pattern number as well.

The arrangement of the parts in order for numbering depends on whether the parts are to be manufactured and fitted in assembling, or fitted each to the other in the process of making. We may take it for granted that the shop is trying at least to do business in a profitable way, so the arrangement will be considered from a manufacturing standpoint. The parts should then be grouped in such manner that pieces having similar operations involved will be detailed on the same sheets. First will come the large castings, like the beds, legs, tables, heads, etc.; after, come the other small castings, involving milling and drilling mostly, as the brackets, levers, braces, gear guards,

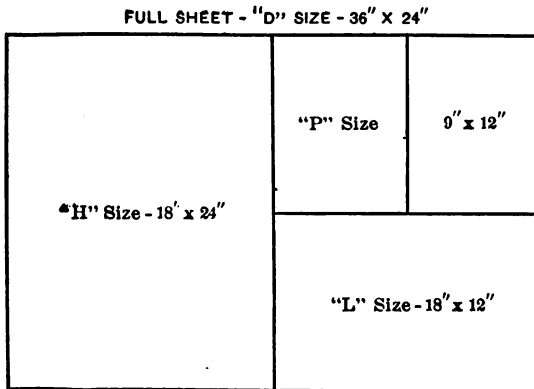

Machinery, N.Y.

Fig. 1. Standard Size Drawing Sheets

etc.; then the castings which are finished mostly by turning, like pulleys, gears, and bronze bushings. Next comes the group which includes the turned parts made from stock or forgings, such as spindles, shafts, steel gears, etc.; followed by a group of the small parts made on the screw machine. The last class contains the parts made by milling and drilling from flat and rectangular stock. If the parts are numbered and arranged on the drawings in some such order as this, the workman who makes a specialty of certain operations will have all his work conveniently grouped together on the sheets.

Standard Drawing Sizes

To obtain the greatest simplicity in handling and indexing in the drawing office, it is necessary to have a single standard size for the sheets. In the shop, however, big blueprints are a nuisance, and the sheets should be no larger than is needed to show a convenient number of the parts in the group being detailed. It is possible to satisfy the requirements of both shop and office by making the tracings of a

standard size, and cutting the prints up afterward into as many smaller sheets as may be necessary. Fig. 1 shows how the convenient 36-inch by 24-inch "D" size sheet may be cut up into the other smaller sizes; thus it may make two "H" sheets, or four "L" sheets, or eight "P" sheets, or two "L" sheets and four "P" sheets, and so on. The smaller size is especially suitable for the parts made on the screw machine. If an extra large sheet is needed for an assembly, or a full-size view of a large casting, a 36-inch by 48-inch sheet, or larger, may be made, folded into the standard sheet dimension, and filed with the rest.

Detailing

Starting in the order in which the parts have been grouped, detail them out on large sheets, sub-divided to suit the case in hand. Don't

B-3	LOT	113 - 130	CHANGES 2-17-04 R.E.F. 6-11-04 A.W.B. 6-17-04 A.W.B.
GEARS IN FEED MECHANISM. N ^o 3 PLAIN MILLING MACHINE. — SMITH MACHINE Co. — BOSTON, MASS.			
DRAWN. R.E.M.		TRACED A.W.B.	
CHECKED. S.A.L.		DATE. JAN. 3, 1904	
B3 - 97 - 130			
<small>MACHINERY N.Y.</small>			

Fig. 2. Lower Right-Hand Corner of Drawing

try to crowd them, but give plenty of room for changes and additions, and leave space in each drawing for adding other parts of a similar group, if this should be required in the future. The lower right-hand corner of each section is ruled off into a title as shown in Fig. 2, containing on the top line the symbol of the machine, in this case B3, which means No. 3 plain miller, then the lot number, which is filled in on the print, and lastly, the list of part numbers included on that drawing. The second line contains in large letters a title descriptive of the contents of that drawing; the next names the machine, and after that comes the firm name and the space for initials and dates. The column at the right, headed "Changes," will be explained later on.

In assigning numbers to the parts, leave a few numbers out at the start to give to the assembled drawings when they are made. Begin by numbering the column, say, No. 15. Leave out two or three numbers, to give leeway, if it is desired to add any new details to that sheet later on, and then number the knee and saddle, for instance, if they come next, 19 and 20. The first sheet then would include Nos. 15 to 18, and so 15-18 would be printed in the proper space in the top line. The drawing with the knee and saddle, containing only these

two details might be numbered 19-23, and so on. In the same manner, if the first group ends at 60, begin the next group at 100; that might end at 271 and the next begin at 300, and so on. Thus parts and drawing will be numbered in a flexible way which will make additions easy without deranging the list of parts. In the margin at the lower right-hand corner of the sheets should be placed the numbers inclusive of all the details on all the drawings of that sheet, as shown in the sample title, Fig. 2. This is for convenience in filing the tracings.

Dimensioning

In detailing, the way in which the parts are dimensioned, the completeness of the information given by the dimensions and the notes,

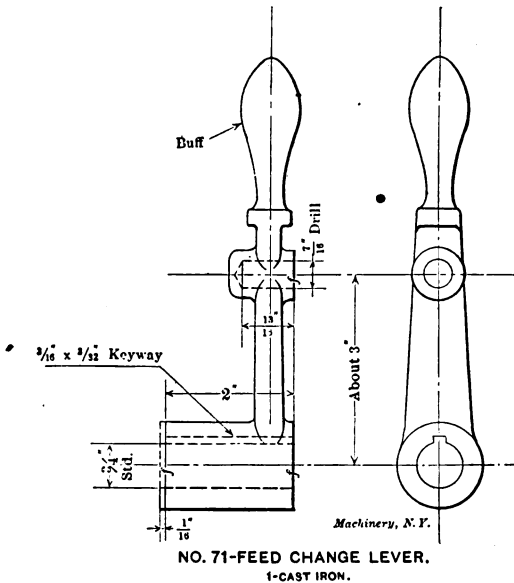

Fig. 8. Detail Drawing

and the clearness of the drawing itself, all these points together make the difference between help and hindrance. Much has been written in mechanical papers, and much more said in the shop, profanely and otherwise, about the dimensioning of drawings. The draftsman must keep in his mind's eye the whole course of the manufacture of the piece, and give the dimensions in such manner that the workman will not have to add or subtract or multiply or divide this and that to obtain the measurement he requires. Of course no scaling of drawings is allowed in the shop. The ideal to be kept in mind is that of a drawing having information so completely given that the wayfaring man, though a fool, need not ask questions, but take the blueprint, follow it in blind confidence, and turn out work all completed save for

the little squaring up of shoulders that may be needed in fitting it in place in the machine. In Figs. 3 and 4 are shown detail drawings, which more or less completely illustrate this idea.

Fig. 3 shows a cast-iron lever. The handle is not turned, but buffed, as noted. Since the body part has no finish given, it is painted to correspond with the rest of the machine. The ends of the hub and the face of the boss are marked "f," which means "finish." This idea is sometimes carried out more completely by making f^g , for instance, mean a ground surface, f^s , a filed surface, f^t , a smooth-turned, but it is much less confusing to write out in plain English whatever finish may be required other than that left by the cutting tool. Do not be afraid of putting on the drawing any notes which will aid the operative. "Finish" is often indicated by a red line about 1/16 inch outside of the finished surface and parallel with it. This is the best and clearest way on paper drawings, and blueprints as well, when the red lines print well, but it takes good paper and careful printing.

The dimension from the center line of the hub to that of the boss is marked "about 3 inches." This means that the centralizing of the holes in the casting is of more importance than the actual dimension given. The hole in the hub is marked $\frac{3}{4}$ -inch "std.," or "standard," which means that it is to be reamed to fit a standard plug gage. The hole in the hub is marked "drill," which shows that it is not to be reamed or fitted, but left as the drill leaves it. It will be noticed that a "fit" of 1/16 inch is indicated at one end of the hub. The workman who squares up the casting at this point must leave 1/16 inch for the fitter to remove in putting the machine together. In the same way "fit" is indicated on the drawings of all shafts, etc., where it is necessary to square up a shoulder to make an end fit. This relieves the lathe hand of all speculation as to where his fits come. Under the detail are placed the part number, the name, the material of which it is to be made, and the number wanted for each machine.

There are no casting or pattern dimensions given in the detail. It is an unmitigated nuisance to have the shop drawings obscured by a maze of dimensions which are never used but once, when the pattern is made. These pattern figures may be placed on the paper drawing from which the tracing is taken, or they may be put in with a yellow pencil on a blueprint taken specially for that purpose. Of course, when it is necessary for a finished surface to bear a definite relation to a rough surface, dimension lines may be drawn from that point, but otherwise the shop should have to do only with the finished surfaces.

The detail drawings for the patternmaker should show the draft plainly wherever it is required, show the manner in which a finish cut terminates in the rough casting, and, in general, give a true picture of the piece as it will look when finished in cold metal. This relieves the patternmaker of all guesswork as to whether he ought to add or take off the draft, and, when combined with careful pattern-making, furnishes a record of the exact shape of the castings, which will be useful in estimating clearances in future changes.

Fig. 4 shows a sample detail of a steel pinion and shaft. Limits

are shown for all the diameters. The determination of limits calls for good judgment on the part of the draftsman. It is very natural for him to put the standard much too high, while the shop often complains of the closeness called for, not realizing that by the old cut-and-fit method much closer work was done than is needed or called for under the limit system. Limits may be expressed in two ways. For instance, a running fit on a shaft to go in a $1\frac{1}{4}$ -inch standard hole in a bronze box may be marked $1\frac{1}{4}$

—0.001 max.
—0.0015 min.

or it may be expressed

0.249
0.2485

The first way may be best for shops where the workmen have not yet become acquainted with their micrometers, but it savors strongly of the " $\frac{7}{8}$ inch plus $\frac{1}{32}$ inch less $\frac{1}{2}$ of $\frac{1}{64}$ inch" of our forefathers.

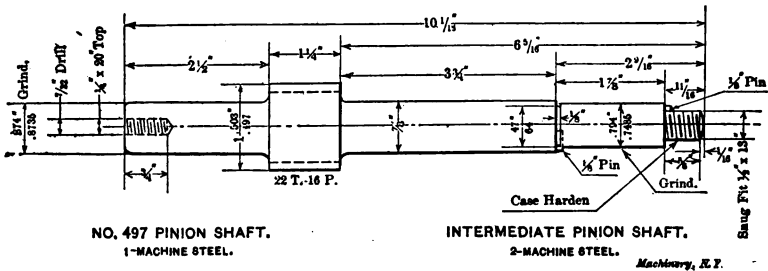

Fig. 4. Another Example of Detail Drawing

In the better shops of the country the very errand boys learn to use the micrometer with ease and skill, so it would seem that the second method of marking the size ought not to puzzle the workmen very long. In either case the larger dimensions should be on top, to catch the eye first. In places where there are no limits given, of course it is understood that good, accurate scale measurement will do.

On the drawing, the tap drill size and the depth of a tapped hole are shown. The two journals are marked "Grind," which means "grind to size"; the one into a plainly shown recess, the other, where the box does not come within $\frac{1}{2}$ inch of the shoulder, up to the fillet. In general it is intended that the dimensions shall be so arranged that the lathe hand will be able to use them as they stand, without bothersome calculation. On work made from the round or rectangular bar, finish marks are omitted. If it is desired that the piece be left rough at any point, the words "stock size" may be applied to the figures describing that dimension. For instance, on a $1\frac{1}{4}$ -inch cold-rolled shaft turned up for a short distance at each end, the central part would be dimensioned $1\frac{1}{4}$ -inch "stock size." This particular piece is used twice in the construction of the machine, and in different localities, so it is given two names under the same part number.

Part Lists

Two lists are required: A list of detailed parts, and a list of stock parts. Every single item of a given machine must be recorded somewhere, either on the blueprints or in the list of screws, washers and other sundries taken from the stock-room or purchased outside. A page heading for the list of parts in the casting group is shown, upper sketch, Fig. 5. The first column gives the part number; then comes the name, then the number wanted, the material of which they are cast, and lastly, two columns marked "castings ordered" and "order filled." These spaces may be conveniently checked by the one who orders the castings, and he will thus have a good idea at any time of what progress is being made in supplying the needed material. This does not, of course, take the place of whatever foundry order system may now be in use. The page heading of the parts made from the bar and rod are also self-explanatory, the last two columns being filled in with the dimensions of the rough stock needed to make each piece. It will be remembered that numerous blank spaces were left

CASTING PARTS.	PART No.	NAME	No. WANTED	MAT'L.	CASTINGS ORD. NO.	ORDER FILLED
	115	<i>Use Body</i>	1	C. I.		
	116	<i>Use Suvvel Base</i>	1	C. I.		
	117					
	118					
	119	<i>Table Stop Blamps</i>	2	C. I.		
120	<i>Table Stop Abutment</i>	1	C. I.			

BAR STOCK PARTS.	PART No.	NAME	No. WANTED	MAT'L.	SECTION.	LENGTH OF BLANK
	411					
	412	<i>Vertical Feed shaft</i>	1	M. S.	$1\frac{1}{8}$ " Diam.	13 $\frac{1}{4}$ "
	413	<i>Elevating Hand Wheel shaft</i>	1	C. P. S.	$1\frac{1}{8}$ " Diam.	17 $\frac{1}{16}$ "
	414	<i>Telescope shaft</i>	1	M. S.	$1\frac{1}{8}$ " Diam.	15 $\frac{1}{2}$ "
	415	<i>Telescope Axle</i>	1	STEEL Tubing.	$1\frac{1}{2}$ " x $1\frac{1}{4}$ " Diam.	12 $\frac{1}{8}$ "

MACHINERY N.Y.

Fig. 5. List of Detailed Parts

in numbering the parts, to give room for future changes. Similar gaps should be left in the list of parts.

The "List of Stock Parts," of which two sample headings are shown, Fig. 6, covers everything not otherwise provided for, and gives all the information necessary for ordering. Leave plenty of room here, as well, for additions and alterations. These lists may be done in ink on printed and ruled blanks of thin bond paper, or they may be type-written for blueprinting in the following manner: Do the work in a good strong manufacturing machine with a new black ribbon. A piece of carbon paper should be placed in back of the sheet with the face against it. This prints the back of the sheet as well as the front, and makes characters heavy enough to make good blueprints.

If these lists are printed, clipped together in tough paper covers, and distributed generally among those who have any use for them, they will save a vast amount of useless mental strain. Before a new lot of machines is ordered, the stock-keeper can go through the list and see

that he has got every screw and washer on hand that is needed. The man who orders the castings can look over the supply on hand and govern himself accordingly. The man who has charge of the bar stock can keep himself supplied with the necessary material, and cut it off of the proper cross-section to the proper length, as fast as it is needed. The foremen in the shop can assure themselves that nothing has been forgotten, that everything is coming along as it is wanted, and have in general a constant reminder at hand of what is required of them.

Assembly Views

After all this has been done, we may make the necessary assembly views, working entirely from our detail views and stock part list. If the parts all go together as required, it is an indication that the job will check up well. On these drawings, at least, and perhaps on the details, it is a good plan to use some simple method for distinguishing the various classes of materials by cross-sectioning. It is

LIST OF SQ. HEAD SET SCREWS.

NAME OF SCREW.	NO. WANTED	DIAM.	LGTH.	MAT'L.	FINISH.	POINT.
To hold Dog # 89 on Shaft # 417	4	$\frac{3}{8}$ " x 10"	1 $\frac{3}{4}$ "	Steel.	C.H.	Cup.
" " Rod # 468 on Bracket # 111	1	$\frac{3}{8}$ " x 16"	1 $\frac{3}{4}$ "	Steel.	C.H.	Cup.
" " Star # 126 on Shaft # 439	2	$\frac{3}{8}$ " x 16"	1 $\frac{3}{4}$ "	Steel.	C.H.	Cup.
" " Stud # 488 in Holder # 97	5	$\frac{3}{8}$ " x 18"	1 $\frac{3}{4}$ "	Iron.	Soft.	Oval.
" " Rod # 512 on Pivot # 542	12.	$\frac{3}{8}$ " x 18"	1 $\frac{3}{4}$ "	Iron.	Soft.	Oval.

LIST OF FURNISHINGS.

DESCRIPTION	AMT PER MACH.
Single Belting - made Endless - First Qual. - 1 $\frac{1}{2}$ " Wide.	13 Ft. - 7 In. Endless
Single Belting - First Quality - 1" Wide.	49 Ft.
Round Belt - $\frac{1}{4}$ " Diam - Furnished with Couplings.	3 Wanted - 11 Ft. each
"Cosmolubric" Oil.	2 $\frac{1}{2}$ Gall's

Fig. 6. List of Stock Parts

MACHINERY N. Y.

good enough to have one style for steel and wrought iron, one for brass, bearing metals, etc., and one for cast and malleable iron.

Tracings

Next comes the tracing. If the machine is a new one, never built before, it is a good plan to shellac the paper drawings and send them out into the shop for the first lot. This will make the inevitable changes easier to handle than when blueprints are used from the start. As soon as the machine is well in hand, the drawings may be recalled, cleaned with alcohol, and traced. It is of great importance to use the very best grade of tracing cloth. Not every well-advertised brand will stand the rubbing and scrubbing for a draftsman who has the fever of improvement seething in his brain. It costs much less to get the best tracing cloth at the start than it does to have to make new tracings on account of having cloth that will not stand erasure.

Checking

The checking may now be done. It is best to delay this until after the tracings are completed, and then it is done once for all; and it

can best be done by some one other than the man who did the detailing. If, however, it be gone over in some orderly, systematic way, it may be as well done in a one-man drafting-room as in some large establishments, where the drawings are examined and initialed by every one in sight, from the engineer in charge down to the tracer.

Think over beforehand every direction in which a mistake is liable to occur, and make a table covering these chances of errors and tack it in plain sight on the wall over the desk. For such a system as that we are considering, the following list might be appropriate:

1. General design.
2. Finish.
3. Dimensions; sufficiency and arrangement.
4. Dimensions; compared for accuracy.
5. Compare with list of parts.
6. Compare with list of stock parts.
7. Pattern number.
8. Notes.
9. General title.

That is to say, beginning with the first part in the list of detailed parts, we would examine it first for points in its general design. 1. Is it well proportioned, strong enough, and in general harmony with the lines of the rest of the machine? Could it be changed so as to require less machining, or to make it cheaper to mold (if a casting)? 2. Is there any unnecessary finish, and has the needed finish been properly indicated? 3. See that the dimensions are sufficiently full, and arranged in such manner that the workman will know, without figuring, the dimensions he needs. 4. Compare the dimensions of the detail in hand with those of every single contiguous and related piece in the whole machine, whether detailed or given in the list of stock parts. This is the important item in the list, and if it is faithfully carried out, it will double-check every dimension, as each part is thus checked up once individually, and again in the checking of other related parts. 5. Compare titles and stock dimensions with entries in the list of detailed parts. 6. See that every stock part which is related to the detail being considered is properly entered on its list. 7. If the detail is a casting which has no pattern of its own, but uses that of some other part of the same or another machine, see that the proper pattern number is given under the title. 8. Be sure that notes are given, to supply the workman with all the information he needs as to fit, finish, etc. Otherwise he will worry the foreman with fool questions. 9. After the details have been checked, as above, see to it that the title of the drawing is correct as to part numbers, names, etc.

In the same manner the lists must be gone over, checking every name, number, note and dimension.

Printing, Mounting, Etc.

The tracings may now be blueprinted, cut up into the proper sections, and mounted on suitable boards. Do not send them out rolled up, to get defaced and torn, and refuse to lie flat in the files, when

they are returned. When mounted, they are distributed to whoever needs them. With the details intelligently grouped as described above, and with not too many on a drawing, one set of detail prints ought to suffice to put through a single lot in the shop. Be generous with the lists, however, and put them wherever they can be of any service. Stamp each print, in red, with the date when it was printed, and keep a record of prints made and delivered to the shop. This record will be found very valuable when making changes as described below.

Changes

In a shop which is alive, the product is in constant process of improvement, so it is necessary to make a full provision for this state of affairs in a good drafting-room system. In the first place, the men in the shop should on no condition be allowed to make an erasure or addition of any kind to the shop prints and drawings. If an error is discovered or an improvement found advisable, let it be reported at once to the draftsman, who should stand ready to make any needed change with promptness and good grace. In general practice, however, it will be found best, from the drafting-room standpoint and that of cheapness of production as well, to delay radical changes until a new lot is begun. In some places the foremen and other prominent men are furnished with stub books in which they write suggestions for the improvement of the different lines of machinery. The leaf is filled out in duplicate with the stub, and sent to the drafting-room, where it is considered either immediately or when a new lot is ordered, according to the urgency of the case. This scheme gives the draftsman the advantage of having all the suggestions in a tangible form, for ready reference, and also gives the credit to the men who hold the duplicate stubs.

In the same manner as was done when checking, it will be found advisable to make out a list of everything which might require attention in making alterations of any kind. The following table would cover about everything. This ought also to be printed and nailed on the wall in plain sight of the draftsman:

1. Detail tracings.
2. Assembly tracings.
3. List tracings.
4. All prints (detail, assembly and lists).
5. Patterns.
6. Special tools.
7. Record of changes.

In making a change, if it is at all elaborate, it is safest to sketch it out on detail paper before making changes on the tracing. In erasing tracings, use any smooth sand eraser which has been approved by experience, and place under the part being treated a sheet of some smooth hard substance like celluloid, sheet metal, or a round-edged piece of glass. This will remove the ink without giving the rubber a chance to deeply abrade the cloth itself. Cases sometimes occur in which a comparatively simple change, like shortening the over-all

length of a complicated casting, would entail a considerable amount of labor. To avoid this, the dimensions only may be changed, and then a small heavy circle drawn around each dimension. If on a paper drawing, draw the circle with red ink; if on a tracing, use black ink. This gives notice to whomsoever it may concern that the dimensions are out of scale, so that the drawing will not measure correctly. Where the change is one of $1/32$ inch or less, it is not advisable to alter the lines of the detail or circle the figures.

The assembled drawings should be kept up to date if they are to serve any purpose at all. In some cases it might be permissible to introduce circled dimensions on these tracings as well, where an otherwise small change would require much erasing. The lists also must be corrected, of course.

There are two ways of changing the blueprints, where the change is so small as to make a new print inadvisable. One way is to use the "soda solution" which acts chemically on the paper itself. This gives the most permanent results, but requires some skill in handling, as the lines do not appear until some time after the liquid has been applied. Chinese white, ground in water, can be used like ink, and easily removed when desired—so easily, in fact, that it is best to shellac the changed portion of the print to preserve the lines. With either method it is best to draw in the new lines first, and then obliterate the old ones with a blue pencil, this being the only known method of erasing on a blueprint. Be sure that every print of each tracing is changed—the list of prints changed should take care of this. If new copies of a print are required on a change, destroy the old ones; do not leave them lying around, to cause trouble.

Patterns and special tools must be looked up for each individual case, and duplicate written orders made out for changes, one to go to the toolmaker or patternmaker, and the other to be kept in the office as a record until the work is reported finished.

Referring again to Fig. 2, there is shown at the right of the title a column headed "Changes." After each change is completed and checked up, the person making the change should enter here his initials and the date, in small legible characters. A "Record of Changes" book should be kept. Under the date signed in the "Changes" column there should be entered a brief description of the alterations, giving exact dimensions, and perhaps the reason for them as well. A separate book should be kept for each line of machines manufactured. By comparing the last change date on a print with that on a tracing, it can immediately be determined whether or not the print is up to date. By referring to the given date in the "Record of Changes," the exact scope of the alteration can be found at any time. This will be found a great convenience.

In cases where an error has been made in the shop on a machine, and a deviation from the drawings in that particular case will save a large amount of costly labor and material, such change may be made; but it must be recorded, for convenience in making future repairs and attachments. It is the proper thing to number the machines of a

given kind and size serially, beginning, for instance, by numbering the first 20-inch lathe built, No. 1, the next one No. 2, and the one hundred and seventy-eighth one No. 178, and so on, as long as the machines are built. This number should be stamped in a prominent place, and attention called to it in the catalogues and other printed matter of the firm. A book for a "Record of Machines Shipped" should be kept, with a page for each individual machine. This page is numbered with the tool's serial number, and contains name of person or firm to whom the machine was sold, a record of the inspector's tests, a description of any change from the standard drawings used on other machines in the same lot, and a record of all attachments furnished, repair parts sent, complaints from user, etc. It is easy to see the value of such a record as this in furnishing new parts, remedying defects, and estimating the values of various designs.

After each lot of machines has been approved ready to ship, all the prints—detail, assembly, and lists—should be returned to the office. A complete set should be taken from them and the duplicates destroyed. File this set of blueprints away in a folio the size of the "H" sheet, doubling the "D" size to do this. As far as the work done in the home shop is concerned, this, with the office book, will furnish a record of each individual machine for all time, no matter whether it goes to Klondyke, or stays in the town where it was made. These folios should be kept indefinitely.

Drawings for Jigs and Fixtures

It is not feasible to try to make the tool drawings of jigs, special cutters, etc., on full-size sheet, even though divided, as the standard parts are. These should be made on a suitable standard size of a good grade of detail paper in a quick, sketchy way, shellaced, and sent into the shop. Number these drawings with the symbol and part number of the detail for whose manufacture they are used, adding a serial number as well. This serial numbering is common to all tools made, no matter for what purpose, and is to be given them in the order the drawings come from the office. Thus if L 22-75 is the part number for the spindle of the No. 4 vertical miller, the finishing taper reamer for the hole in the same might be numbered L 22-75-193. If A 4-267 is the index worm-wheel for the No. 4 universal miller, and the next tool drawing made is a hob for same, it would be numbered A 4-267-194. These numbers should be stamped or etched on the different tools as soon as they are made.

A book should be ruled up for a "List of Tools." A sample page heading is shown for this in Fig. 7. The tools are entered serially as fast as drawn. The first column gives the date when drawn, the main part of the page, the description. Next is a space for a list of parts for which this tool is used other than the one it was made for. As changes are made, old numbers are crossed off from here and new ones added, so plenty of space must be allowed. For convenience in finding the drawing, the last column gives the standard size of sheet on which the tool was drawn. It will be noted that one tool is marked "None."

This tool was made in the shop off-hand, without any drawing to go by, but it was entered on the list, and its tool number marked on it, to give it a local habitation and a name. These tools and jig sheets should be filed in a drawer of their own, divided into compartments of suitable size, and all arranged with serial numbers in order, the lowest at the bottom. The jigs and tools themselves are best arranged with the serial numbers in order, since they will avoid constant rearranging as the stock increases. To find them readily, an index list should be prepared, giving the standard machine parts in numerical order, and listing under each one all the special tools used in its production, whether those tools were originally used for it or not. Of course much of this system of keeping track of special tools is required only in shops where they are used in large numbers, but that may be taken for granted, if the concern is in earnest about doing a profitable business on a large scale.

Special Machines and Attachments

In cases of special machines or outside work of any kind, which does not come under the head of standard product, the same system may

DATE.	TOOL No.	NAME.	USED ALSO FOR.	SHEET.
2-17-04	H14-76-276	.498" Rose Reamer for bushing holes in <i>dog clide</i>	(H7-96) (K1-72) (L14-472)	None
2-17-04	82-28-277	Jig for bushing holes in <i>Sear Box</i>		D
2-18-04	82-28-278	Boring Bar for bushing holes in <i>Sear Box</i>	(G2-49) (H6-82) (L17-24)	L
2-20-04	L17-480-279	Trang Rack Cutter for <i>Trid Rack</i>	(L20-480) (L24-480)	P

MACHINERY, N. Y.

Fig. 7. List of Tools

be followed as a whole, with the exception of the symbol for the machine, which should be given a serial number instead of the letter and size number of the regular product. A record of these serial numbers should be kept in the office, and the drawings filed away, if the job is important, in the same manner as the standard blueprints. Attachments to regular machines, made up separately, may follow the entire system for standard parts. The symbol describing them may be formed by adding a letter to the symbol letter of the machine. Thus AA-3 would be "Vertical Milling Attachment for No. 3 Universal Miller"; BD-4 would be "Rack Cutting Attachment for No. 4 Plain Miller," etc.

In place of the record books suggested, it might be better to use loose leaves, with punched holes, held in suitable binders. These leaves could then have proper entries made on them on the typewriter,

and thus save hand work. It will be noted that in no case are there any forms used in such numbers as to require the use of printed matter, so the initial expense is small. Printed forms, index systems, etc., may be evolved as the shop grows.

Summary of Advantages of System Outlined

In recapitulation, a drawing office managed in some such way as this will give the firm the benefit of the following advantages:

Complete tracings and blueprints, easily filed and indexed, and made in such a way as to give the fullest, clearest information possible to the workman.

Complete list of parts as a convenience in tracing the progress of the work and keeping up the supply of raw material.

Complete list of all stock parts, for the benefit of the assembling foreman and the stock-keeper.

A list of all tools used for any given part, and ready means for finding the same, also means for ordering duplicate tools by number from the original drawings.

Means for making all changes entailed by changes in the product in a simple, comprehensive way, and for making a permanent record of same.

A record of the suggestions made in the shop and office, for the drafting-room in making changes, and for the firm in determining the relative value of their employes.

A full individual history, by means of the office record and the filed prints, of each machine built, useful in many obvious ways.

There are many men to whom the suggestions given above will seem the veritable A B C of the business; on the other hand, there are dozens of places where the suggestion of doing things in some such way as this would be considered a dangerous and revolutionary proposition. But practically all the work covered by a good system has to be done by someone, some time, and if it is not done decently and in order, it will be done in vexation of spirit, and with waste of time and money.

CHAPTER II

TRACING, LETTERING AND MOUNTING *

While the previous chapter has dealt with the system of the drafting-room in its relation to the shop, and outlined its functions in a general, although comprehensive, manner, the present chapter is intended to deal with the small details of performing the work in the drafting-room, at the same time as many valuable hints are included with special reference to the young draftsman. In fact, the present chapter has, in particular, been addressed to the beginner, although it has general application.

At the commencement of a drawing-office career only a few tools may be purchased, adding others as they are needed. Careful selection is necessary, and good instruments pay for themselves in the end. A set of drawing instruments comprising a straight pen or two—one for black and one for red ink—a spring-bow pen, bow pencil, and dividers, a six-inch compass with fixed needle-points and interchangeable pen, pencil, and lengthening bar, will suffice. T-square, triangles, pencils, rubbers, erasers, and pens are usually provided by the office. Each man should keep his own instruments, and have a private mark on his triangles, scales and T-square for identification in case they become exchanged.

Small instruments should be put away each night, as in cleaning up the office they are easily lost. A drawer or cupboard with trays or boxes for the various tools is very necessary for the draftsman. A large clean rag duster or brush to wipe the board and T-square occasionally should be provided, as the least particle of dust getting into the pen will clog the ink, causing a poor line to be drawn. In case the eraser must be used (a thing to avoid as much as possible) rub a little French chalk or soapstone well into the part erased. A little of this prepared chalk should always be kept on hand; it can be procured from any artists' material store. A piece of rag, cheesecloth or chamois skin hung by a thumb-tack at the end of the drawing board comes in handy for wiping the pens. A sand-paper pencil sharpener and an oil stone completes the list.

Inks

Too much cannot be said about the inks used, as I believe to a certain extent a great many bad tracings can be laid to the bad quality of ink used in the various drawing offices visited by the author, in this country and abroad.

Good ink is indispensable, and no one should attempt to make a tracing until he has it. Some offices, to save (?) expense, resort to many ingenious ways of making ink by wholesale. A large bottle

* MACHINERY, September, October, November, 1906.

with a ground-glass stopper is provided. A quantity of broken ink (which can be purchased by the pound and much cheaper than buying by the stick or cake) is put into the bottle; a quart or so of ammonia is then poured over the ink. The bottle is then put in a warm place, shaken every now and then until the ink is dissolved, or partly so (the latter usually being the case) when it is supposed to be ready for use. This is the cheapest and worst way of making ink. Some drawing offices buy the ink ready mixed, put up in pint or quart bottles. For shop tracings, either of these methods may be resorted to. But for neat work it is almost impossible to get along with either; the only way is to mix the ink fresh each morning, washing out the pallet every day. When purchasing the ink stick, the very best should be bought; it can be recognized by a pleasant odor which cannot be mistaken and is perceptible when grinding it in the saucer. The saucer, or pallet, should be spotlessly clean, and the water clear. Do not use too much water at first; more can be added as the ink is mixed. A little vinegar in the ink will keep away the flies. In many offices in warm climates they are a great nuisance; the writer has seen whole views completely eaten away by these pests in a very short time. Commence by rubbing a little Prussian blue in the saucer; this is not absolutely necessary, but it improves the ink somewhat and helps to thicken it quicker. Saucers made of slate with ground-glass covers are the best. The ink stick should be held firmly, but do not bear too hard upon it while grinding, or else, when mixed, the ink will be gritty. Grind until the bottom of the saucer cannot be seen when blowing down into the ink; this is a good test, and one can also see if the ink looks gritty. Try it on the edge of the tracing cloth or paper to see if it gives a clear black line. The cover should always be kept over the ink to keep it from evaporating and free from dust. In cold weather, if the ink should thicken, hold it before the fire or heater, when it will run easily and will not clog the pen.

Ordinary scarlet ink is used by some draftsmen for making red lines, although it is much better to use a mixed ink of crimson lake color, adding a little ox-gall to make it run. The prepared ox-gall in tiny jars can be procured from artists' material stores. In the absence of this, a little soap rubbed into the color will answer the purpose. Bichromate of potash dissolved in the water before mixing the ink will help to keep away flies.

It sometimes happens that draftsmen are troubled with sweaty hands which mark the tracing as the work proceeds. This can be avoided by putting half a teaspoonful of ammonia in the water used for washing the hands.

Truing up the Instruments

As the pens are constantly used they will become blunt, which can be seen by holding them against the light and looking down upon the nibs. Every draftsman should be able to set his own instruments. There should be an oil stone in every office for this purpose. Let it lie flat on the window sill or a table near to the light. Screw up the

nibs tight, and, holding the pen in an upright position between the finger and thumb, move it backward and forward, as shown in Fig. 8, along the stone as indicated by the arrows, tilting it from side to side as shown by the dotted lines.

In this way a round and even surface is given to the nibs. They will be of the same length and true with each other. Now, holding the pen in a slanting position of about 30 degrees, rub the nibs upon the stone in a circular direction, as indicated in Fig. 9, rolling the pen as it were between the thumb and finger, turning it over and grinding both nibs alike. Hold the pen to the light occasionally to see if the nibs are level, and look down upon the points to see if the flat sur-

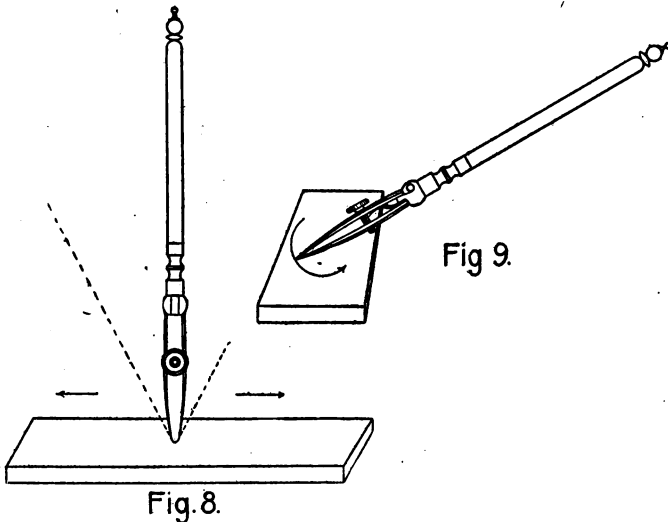

Figs. 8 and 9. Truing the Point of the Pen

faces have been taken out. If sharpened correctly, one will not be able to see anything, the same as when looking down upon the edge of a razor.

The thumbscrew must now be taken out and the inside edge of the pen be rubbed across the oil stone several times. Thoroughly clean the pen from any grit or oil and try it upon the edge of the tracing. If too sharp, it will have a tendency to run away from the T-square or straight-edge, in which case it should be rubbed on the stone again, as in Fig. 8, though with care, as all pens should be fairly sharp. The bow pen is trued up in the same way, with the exception that a thin slip of stone is passed between the nibs to take off any rough parts, as the nibs of the bow pen do not hinge; and when straight pens are made in the same way, they should also be treated in the same manner. All instruments should have the best of care. When not in use for some time they should be kept clean and free from rust by wiping them on a piece of chamois leather greased with vaseline.

Tracing Paper

Tracing paper is much used in architects' offices and occasionally by engineers for pencil sketching. When it is used for permanent work, the best quality should be had. But although it is possible to purchase paper capable of standing fairly rough usage, it is by no means as good as cloth.

A narrow strip of tracing cloth tacked along the lower edge protects the paper from being torn while leaning over the board. Either thumb-tacks, copper tacks, or small carpet tacks may be used to hold down the paper; a small magnetized hammer can be used for the latter, picking the tacks up very quickly, so that whichever plan is adopted, it takes about the same time. In case the tracing will be worked on for some time, or if there is any coloring to be done, the paper must be mounted on the board as described later.

Tracing Cloth

For permanent work tracing cloth should by all means be used. Cloth is either glazed or unglazed, the foreign make being by far the best. With proper care a tracing may be taken up when complete, as clean as when cut from the roll. All shop or working tracings should be made on the unglazed or dull side of the cloth, as this side will take pencil lines nicely, and when erasing has to be done it will not mar the surface so perceptibly. But for show or estimate tracings, where much finer and neater work is required, the glazed side must be used. The lines will be sharper, and the work will stand out much better. In either case the cloth should be laid down in the same manner as the paper. It should then be rubbed down with pulverized chalk.

Laying Down the Tracing

The drawing to be traced is squared up with the board and wiped down with a dry cloth or duster. The roll of tracing cloth is run down the board and cut off to correct size. The edges at either side are then torn off quickly and the cloth is laid down correct side up. A tack is put in the center of the top edge; the flat of the hand is drawn firmly but gently down to an opposite point at the lower edge, the fingers spread apart, while another tack driven between them holds that edge. Run the flat of the hand gently to the one side, driving in a tack; then to the opposite, stretching it well and securing it by another tack. The four corners and all intermediate spaces are then held down in the same manner.

With a dry rag or piece of chamois skin rub some pulverized chalk (or chalk scraped from the stick) all over the tracing cloth, dusting it off with a dry rag or brush. This will cause the pen to bite much better, especially in the case of show tracings where the glazed side is used. Some draftsmen use a little ox-gall in their ink for this purpose, but unless the exact quantity is used, the ink will be very sensitive.

Tracing

Everything is now ready for tracing. Try to understand the work as you proceed. If the job is likely to last long, work on one view

and complete it, as sometimes the temperature of a room will change over night, causing the cloth to become quite flabby, and although it may be stretched again by holding it near the radiator or in the sun, yet it very seldom goes back to its correct position. But when making a smaller tracing which can be completed in a day, put in all the black lines first, the red or blue lines next (when making show tracings), the printing or lettering next, and finally the border and cutting-off lines. Although as a rule red and blue lines are put in last, there are a few exceptions, as, for instance, when tracing a number of bolt or rivet heads in bridge or girder work; if a red line is run

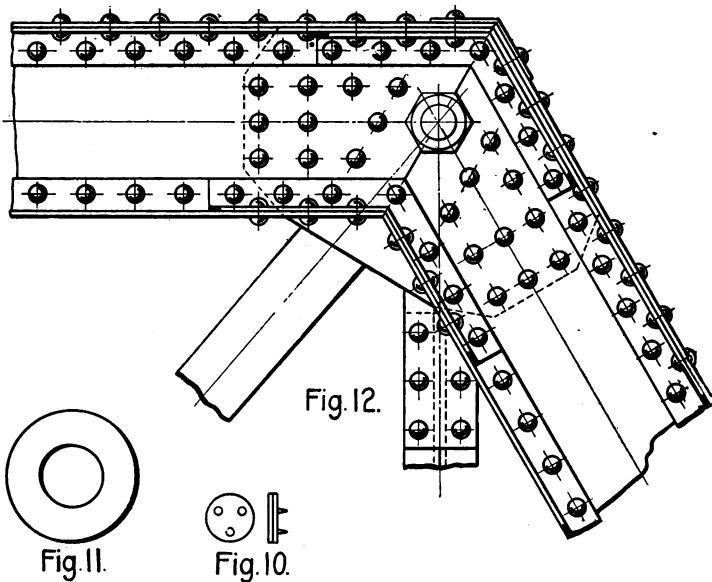

Figs. 10, 11 and 12. Horn Center, and Examples of Shading

right through the heads, it will be easier to get them all exactly true and in line; otherwise they are apt to be put in a very zig-zag way.

If the drawing is crowded, the best plan is to stick to the rule and put red lines in last, as otherwise they will make the drawing hard to read by covering up work not yet traced. As a general rule, commence with the circles and curves first, joining the straight lines onto the curves, and not *vice versa*. When a number of circles and curves are struck from the same center, always commence with the smallest or inner one first, while the center is good.

Sometimes a horn center, shown in Fig. 10, is used to protect centers from which a number of curves or circles are struck, as in gear wheels, for instance. These horn centers are circular pieces of horn with three needle points. Some draftsmen glue a small piece of hard wood or horn over the centers. The pens should be tried upon the edge of the tracing to see what thickness of line they make, and when once set

they should not be moved; for this reason some pens have small lock nuts on the thumbscrews. They should be wiped and the ink put in without again adjusting the screw. This particularly applies when making heavy lines. In this way all lines will be of the proper thickness. The pens can be filled with an ordinary writing pen or dipped in the ink sideways.

Working Tracings

Working tracings or shop tracings are usually made a little heavier than others. The lines should be all of the same thickness. No red or blue lines need be used, but all black, and although the tracings should be neat, especial care being given to the figures and dimension lines, yet such care need not be taken as when making a show or estimate tracing. The figures should be plain and simple and might be made a little large. The arrow points should be true and go exactly to their intended position. The figures should be checked before handing in the tracing so that as few mistakes as possible will come back to the tracer.

Show Tracings

Estimate or show tracings should have a little more time expended upon them. The lines need not be so heavy and as a general rule are shaded, *i. e.*, the lines furthest from the light, which is supposed to come from the top left-hand corner, should be heavier than the others; this is clearly shown in Fig. 12. Shade lines can be made by going over the lines again or adjusting the screw of the pen, causing the ink to make a heavier line. When dark-lining a circle the radius is kept, but the center changed slightly, as shown in Fig. 11; or the same center and radius may be kept, going over the dark or shaded side several times with the pen.

The letters, figures and dimension lines should be made neatly, the arrow points evenly made. Some draftsmen put in the arrow heads with their spring bow pen, and since they can be put in just as quickly this way and look much neater it would be well to practice this method. Dotted lines should be finer than full ones. The dots and spaces should be made the same length—about one-thirty-second to one-sixteenth inch in length. In shading rivet heads sometimes a small half circle is made inside the first, as shown in Fig. 12. It should be heavier than the outline of the rivet head.

The heading or title should be neat and attractive and a fancy border line might be made. All notes or stray words should have a neat red line drawn under them. Bolt heads should be neatly made and all small work carefully executed. Threads of bolts should be parallel and equally spaced, and may be accurately drawn or indicated, as shown in Fig. 13, *c*, *d* and *e*. Dotted work can be shown to advantage if the dots forming the apex and root of the threads are united, as shown at *e*. These may seem trifles, but they all tend to make a neat tracing.

Holding the Instruments

The author has been more than surprised at the rough and unsteady way which some draftsmen have of holding their instruments. The

bow pen should be held lightly at the top between the thumb and first two fingers, resting the little finger upon the tracings to steady the instrument while finding the position for the point. This being found, the little finger should be lifted and the bow pen cleverly spun between the thumb and first finger. It is good practice when at leisure to see how quickly one can make a number of small circles; in this way one will get into the knack of cleverly spinning the bow pen as described, instead of holding it in an awkward manner. The straight pen should be held in a slightly inclined position, the thumb-screw on the side away from the T-square or straight-edge, and with the second finger resting upon the screw to adjust if necessary.

Sectioning

Sections are shown in several ways. For working tracings line sectioning is by far the better. Plates and sections in wrought iron or

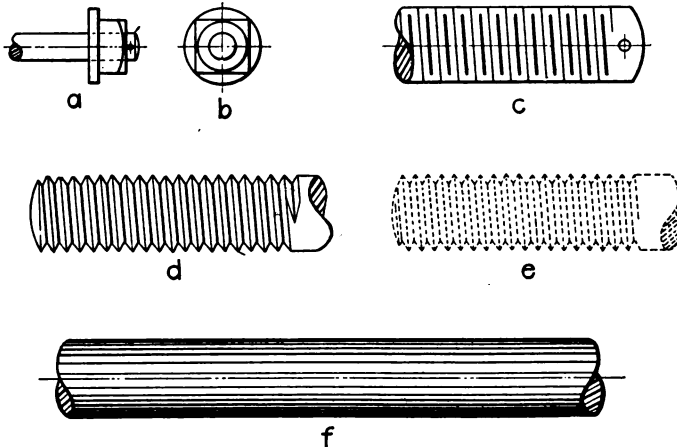

Fig. 13. Screw Threads and Shading

steel work may be blackened, as shown in Fig. 23. A narrow white space should be left between two pieces, as shown in Fig. 21.

A pretty way of showing sections, especially in the case of show tracings, is to represent the various metals, wood, etc., by broken and full lines, as shown in Fig. 14. These conventions are in common use, but in case there should be any doubt as to whether they will be generally understood it would be well to make a small note to one side, naming the material.

A neat little tool for section lining is easily made from a slip of wood a little thicker than the triangle or set square used by the draftsman, as illustrated in Fig. 15. The notch cut in one side is a little longer than the side of the triangle. Resting the thumb upon the T-square, the first finger upon the sectioner and the second finger (all of the left hand) upon the triangle, they are alternately slipped along each time a line is drawn with the pen. With a little practice, sectioning can be done quicker than by using a triangle and T-square

only, trusting to the eye for correct spacing. Section lining done this way looks very neat and even. Another section liner, shown in Fig. 16, can be made to fit triangles having a recess in the center.

Views in section are sometimes colored, generally on the back, turning the tracing over and tacking it down again; or, where there is much coloring to be done, the tracing should be mounted as described under that head at the end of this chapter; otherwise the color will

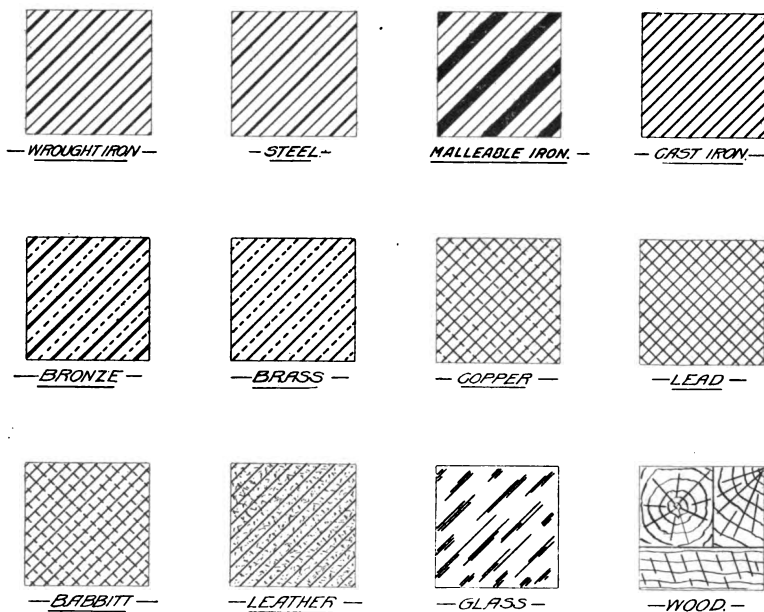

Fig. 14. Cross-Sectioning *

cause the tracing to buckle, giving it a very untidy appearance. Having stretched the tracing, one may be mixing the colors while it thoroughly dries. The colors should be rather thin, and to make them run evenly a little prepared ox-gall should be mixed in well with them. This should not be omitted, as otherwise the colors will present a very smudgy appearance. Some draftsmen use a small piece of soap in place of the ox-gall.

By trying the colors upon a scrap piece of tracing cloth or paper and turning it over, the proper shade may be obtained.

* There is no universally adopted standard for cross-sectioning for the purpose of indicating different materials. The chart above does not agree fully with the charts given in any of a number of text-books on mechanical drawing, but as these at the same time do not agree with one another it has been assumed that the chart above represents as good practice as those in the text-books. A chart, similar to this, but differing in a few instances, and more extensive, was given in MACHINERY'S Data Sheet No. 15, December, 1902. There being no recognized standard, however, cross-sectioning alone should never be depended upon for indicating materials to be used. Written directions should also be given, or a small chart placed in a corner of the drawing, indicating the conventions used in designating the various materials.

Following is a list of representative colors used in many offices:

- Cast iron.....Payne's gray.
- Wrought iron.....Prussian blue.
- SteelCrimson lake and small quantity of blue.
- BrassYellow.
- CopperCrimson lake and yellow.
- BrickCrimson lake.
- WoodBurnt sienna.
- EarthDaubs of ink, Payne's gray, etc.

In the absence of Payne's gray, a pale wash of India ink in which has been mixed a little Prussian blue may be substituted. Very neat

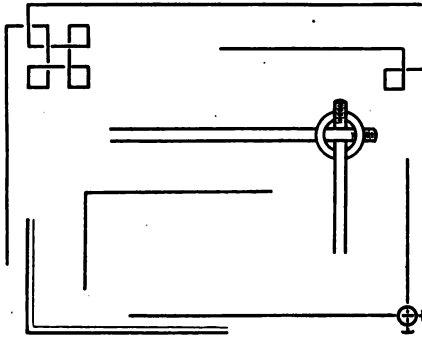

Fig. 18.

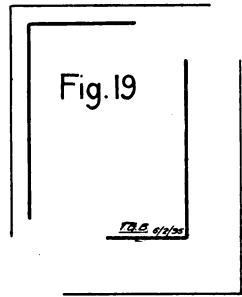

Fig. 20.

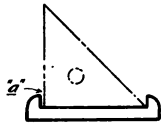

Fig. 15.

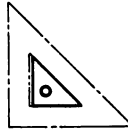

Fig. 16

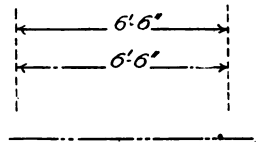

Fig. 17.

Figs. 15 to 20

sectioning can be made with crayons, toning them down with a soft rubber.

Dimensions and Center Lines

Working tracings should have the dimension lines, center lines and all lines black ink, the idea being to make a neat, distinct tracing for use only, whereas a show or estimate tracing should be made with greater care. It is a well-known fact that many contracts have been awarded on the merits of a well-executed piece of-work by the draftsman. The time and expense spent upon making a neat show tracing is never lost. Make the center lines of red ink or color, a fine long dash and dot line; make dimension lines either one continuous line broken only where the figures come, or a dash and dot line, as in Fig. 17.

Border and Cutting-off Lines

Simple as these may seem, yet many well-executed tracings have been spoiled by either neglecting a border line or making a very poor one. A one-line border is perhaps the best and its thickness should match the work in hand, together with the size of the sheet. There should be plenty of margin between the border line and the work. A fancy border line, of which a few samples are given in Fig. 18, may be put around estimate or show tracings. The cutting-off line should not be too near the border line, say, from $\frac{3}{4}$ inch to 1 inch. Nothing looks worse than to see a good tracing spoiled by cut-



Fig. 21.



Fig. 22

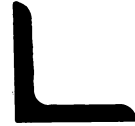

Fig. 23.



Fig. 24



Fig. 25

Figs. 21 to 25

ting off within a quarter of an inch of the border line (compare Figs. 19 and 20). The initials of the draftsman and date tracing was made should not be omitted.

Miscellaneous Directions

Attention to details is perhaps the true secret of making a neat tracing. No matter how trifling a detail may seem, it should be made as neatly as the rest of the work. Channels, angles, etc., in section, should be made accurately, as in Fig. 23. Do not make them, as is so often done, like Fig. 22.

When tracing a blueprint, the tracing should be tacked down with few tacks, as it will have to be lifted quite often to see the work distinctly; in fact, in many cases it would pay to make a drawing from the blueprint and trace it. Drawings which are faint or unfinished should by all means be made clear before attempting to trace them, thereby sav-

ing much patience, but in particular the eyesight. In tracing from another tracing, a clean sheet of white drawing paper underneath will make it stand out clearly. If the draftsman understands what he is tracing, the work will be much easier and he will not be likely to make so many mistakes as he would if tracing a number of meaningless lines.

The tracing should be wiped down occasionally with a clean, dry duster or cloth. Cotton sleeves are sometimes used to protect the coat. A sponge-rubber or piece of bread may be used to clean a tracing, but if proper care has been taken, a tracing can be taken up as clean and neat as when tacked down. A greased, soiled tracing shows

POSITION OF CYLINDERS.
STARBOARD ENGINES.
QUADRUPLE EXPANSION ENGS.
24-36-51½-74 × 42. NOS. 218-19-20-21.
THE GLOBE IRON WORKS CO.
CLEVELAND, OHIO.
SCALE $\frac{3}{4}$ "=1'-0" JUNE 6TH 1890.

Fig. 26. Example of Lettering a Drawing Title

a bad workman. In some offices it is the practice to sponge the tracings down with benzine. Waterproof ink must be used by all means if this plan is adopted. When the tracing is complete, the draftsman should look over it carefully, trying to detect any errors, as all such count against him. The shop hands, as a rule, are only too pleased to point out any trifling mistake coming from the drawing office. Accuracy, as well as neatness and quickness, is desirable.

Lettering

No matter how neatly or carefully the working lines of a tracing are made, if the lettering and figures are not satisfactory the tracing will look poor in every sense of the word. The young draftsman should, therefore, take especial care to get into a neat way of lettering, and should devote a little of his spare time each day to this end if he wishes to excel as a neat draftsman. Neat letterers are in demand and are always sure of a position. Many cases are known, for instance, where a good letterer has been employed in his spare time to put on the figures and letters of other men's work, and although a poor tracing can be improved by neat lettering, to excel in both should be everyone's desire.

A good instruction book on this subject is difficult to find. Most alphabet books are ridiculous in the extreme; it would take longer to make the letters they describe than the whole tracing. The tracings would look insignificant in comparison with the wonderful lettering. The letters and figures must conform to the other work—neither should be more conspicuous than the other. For this reason it is

preferable for each man to complete his own tracing. It is an easy matter to tell who made the various tracings in most drawing offices by the peculiar characteristics of each draftsman—this one by its poor lettering or that by a beautiful harmony of lines, letters and figures, the whole standing out in correct proportion, fine lines having small neat figuring, lettering, and narrow points to match, or heavy lines *vice versa*. Nothing looks more uniform, neater, or is quicker done than good, plain, one-line lettering, even for the titles, though perhaps a little display may be given to them.

A few samples are here given. The small letters are for the general working parts of the tracings, notes, etc. Headings should be a little

The following alphabets are used in most offices employing mechanical or structural draughtsmen. The student should practice these until he gets into a free and easy way of lettering. He should practice making the letters larger and smaller than here shown also.

ABCDEFGHIJKLMN OPQRSTUVWXYZ
(Capital letters for titles and headings)

abcdefghijklmnopqr stuvwxy z. 1234567890

— GENERAL PLANS —
— BLAST FURNACES & ROLLING MILLS. —
— COLUMBLA IRON COMPANY. —
— Scale 1"=100 Feet. —
— Smith Jones & Company —
— Engineers —
— Feb. 6th 1906. —

266

Fig. 27. Examples of Lettering

larger, and the title, which will be referred to later, should be distinguished from the rest of the work by using large letters, either blocked out, or capital letters made with a heavier pen. Figures should be made plain and simple, without the use of flourish or tail-piece. Fractions should be made with one figure immediately over the other, instead of to one side. The vertical system of figuring is preferable to the slanting, especially with shop tracings.

For lettering, have plenty of black ink, but not too thick. The best kind of pen points are Esterbrook's No. 333, or Gillot's 303 for fine work. A heavier pen must be used for titles. Make the letters and figures with one stroke of the pen; do not go over them again, but get the required thickness, even with titles, by bearing on the pen

more. A pen can be tempered, when new, by holding it in the flame of a match, though pressing it on the thumbnail is generally sufficient.

Headings or Titles

The heading or title should be in a conspicuous place, and as far from anything which may tend to crowd it as possible. The bottom right-hand corner of the sheet is a good place. A heading sometimes looks better without lines drawn underneath, as shown in Fig. 26.



Fig. 28. Alphabets for Lettering on Drawings

This is entirely optional, however; if lines are put under they should not be too close to the letters. Black letters are sometimes used, which can be made by drawing six pencil lines equally spaced, as shown in Fig. 24. The T-square and triangle are used, and the letters can be made quite rapidly. They should afterwards be filled in, or one edge of the letters made heavier, according to the nature of the work in hand. Sloping letters can be made in the same way by using an adjustable-headed T-square or a special triangle made for that purpose.

Stenciling

Sometimes headings, letters, figures and corner pieces are put on by means of stencil plates cut out of tin or copper sheets. A stiff, short stencil brush is used. The brush is moistened with water, not using too much, and is then rubbed along the stick of ink until it cannot absorb any more. Particular attention is called to this, as here is where so many fail in making clean and clear stencil work; the brush should never be dipped into a saucer of ink, or the ink applied with a pen.

The position for the title having been settled, pencil lines should be drawn on the cloth as a guide for the stenciling. Sometimes the title or heading is stenciled upon a spare piece of cloth or paper first, then slipped into place under the tracing and the stencil work done over it. This is a good plan, as the correct position may thus be obtained. If this is not done, the only way is to make a pencil tick mark after each letter to indicate the position of the next, as, of course, the stencil plate will hide all beneath it except the letter being stenciled. Then the letters must each be filled in, as shown in the first two letters of Fig. 25.

Even when the stencil guide referred to is made and slipped into place under the tracing cloth, a pencil guide line should be drawn and all letters stenciled exactly to it. The pencil lines and ticks are then erased. If the brush becomes dry, it may be moistened on the tongue without again rubbing it on the ink stick. Draftsmen sometimes cut their own stencil plates out of stiff drawing paper, applying a coat of varnish on the upper surface.

Round Writing

When referring to alphabet books, the writer should have made one exception at least, and that is the round writing system. It is easily learned and not soon forgotten. Letters and figures of all sizes and shapes can be made by using different graded pens. Books of instruction and an assorted box of pens may be had from any stationery store of importance.

Mounting Tracing Paper

Tracings likely to be in hand a long time should be mounted to the drawing board, for several reasons. They will be protected from getting torn and will not shift on account of the sudden change of temperature of the room which may take place; they can also be cleaned more safely than if held by a few tacks. The paper should be cut large enough to allow for sticking the edges to the board, and should it be intended to color the tracing with liquid colors, twice the allowance should be made, as the paper will be cut after the tracing is made, and mounted the second time. The drawing to be traced should be laid down square with the board perfectly flat and level, then thoroughly dusted down to remove all obstructions, as these cannot be removed after the tracing paper is mounted.

A long, flat straight-edge with a couple of weights for each end is needed. Having cut the paper, dampen it slightly with a wet sponge, going over it very evenly and working quickly, so that it may be attached to the board before quite dry. The damp side must be up. The straight-edge is placed an inch outside of the cutting-off line and the weights put on, one at each end. Turn up the edge of the tracing paper, as shown in Fig. 29, and apply the mucilage or paste brush, pressing the edge down firmly with a straight-edged ruler or paper knife. The opposite side of the tracing paper is treated in the same way, and then the two remaining sides, care being taken to stretch

the paper carefully by pulling the edge of the paper gently with the tips of the fingers, before the weights are put on the straight-edge. Any superfluous water may be removed with a blotter. The whole operation, as before stated, should be done very quickly, as in a warm room the paper soon dries.

Mounting Paper for Coloring

Should there be any wash coloring to be done after the tracing is made, it is usually done on the back. The tracing is therefore taken up, cutting close to the pasted edge, so as to leave as much margin as possible for the second mounting. The drawing paper is also taken off the board and a clean white sheet, not so large, put in place of it. The tracing paper, being turned over, is again mounted to the board as previously described, care being taken to get no paste inside the cutting-off line, which should have been distinctly marked. While the

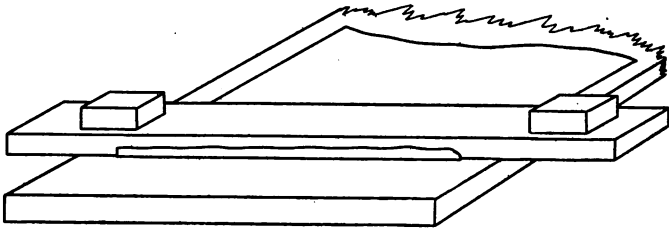

Fig. 29. Mounting Tracing Paper

paper is drying the colors can be mixed. Allow the coloring to thoroughly dry before cutting off the tracing, which should be done with a sharp knife, following the cutting-off line very carefully.

Mounting Cloth for Tracing or Coloring

The process described above is for paper tracings only. Cloth can be mounted in the same way, except that on no account should a damp sponge touch it, but it may be stretched without dampening it at all, though not so satisfactorily. If the tracing cloth is put in a cold or slightly damp place over night it can be stretched very nicely, using a thin glue instead of paste. When one edge is firmly fixed, the other should be pulled very tight and extra weights put on the straight-edge to hold it in place while applying the glue brush. Mounting for coloring is done the same way, it being, of course, understood that the coloring is done only on the dull side of the cloth. Very satisfactory results can be obtained by not mounting tracing cloth at all, but simply using a number of iron tacks driven with a magnetized hammer, as elsewhere described.

Mounting Blueprints, Maps, Etc.

Blueprints, maps, drawings, old tracings, etc., are often mounted on linen or cotton to preserve them. The linen or cotton should be cut larger by several inches than the blueprint, and a drawing board about the same size used. Soak the linen well in water, wringing it out between the hands until all the superfluous water is squeezed out,

when it should be unfolded and shaken out. Lay it across the board and commence tacking one edge, beginning at the center and pulling gently; place a tack about every two inches along the edge of the board, as shown in Fig. 30. The other half of the same edge must be done in the same manner. The opposite edge is done next, stretching the linen well each time before a tack is driven; commence at the middle as before and work toward each end. The two remaining edges are done in exactly the same manner, and all is now ready for the paste, which should be prepared for use before the linen is stretched. The paste can be made either of starch or flour. A sufficient quantity is mixed in cold water to about the thickness of cream. Hot water is then poured over it, gently stirring it meanwhile; the whole is then put in a saucepan on the fire and stirred until it begins to boll over, when it is lifted from the fire, poured back again into the basin, and is ready for use. An apron of some kind is fastened around the neck, reaching to the knees, to protect the clothes from

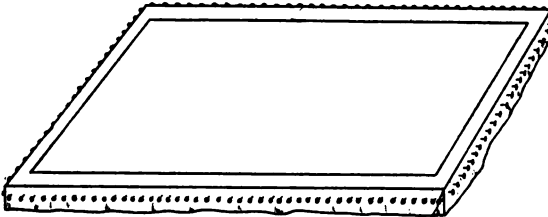

Fig. 30. Mounting Blue-prints and Maps on Linen

getting soiled. Taking some of the paste in the hand, slap it over the board, rubbing it well into the linen with both hands, using more paste if required, until the whole surface is covered. Now, commencing at the lower edge and at the left-hand end, holding the tips of the fingers close together push the superfluous paste along to the center of the board as you travel along from left to right. Go to the opposite side of the board and do the same thing, forming a ridge of paste along the middle of the board, which is scraped off with the hand into the basin. With both hands go all over the board again until the paste is nicely and evenly spread all over the linen.

An assistant is now required. The blueprint is dampened on the back with a sponge and placed gently in correct position on the linen. One-half is to be pasted at a time. The assistant holds it up by the two corners at an angle of about 30 degrees, while with a large blotter in one hand held to the print you rub gently but firmly over it, the assistant letting the print gently yield to the pressure you bring to bear upon it. Passing over to the other half, it is lifted from the board and then treated in the same way. Wherever an air bubble appears it can be pricked with a needle, and the blotting pad placed over it, while with a circular sweep of the other hand you press it firmly to the board. Should any obstruction unfortunately have been left between the print and the linen a slit can be made in the former and the obstruction removed when it is again pressed to the board.

The whole should thoroughly dry before any attempt is made to tear it from the board. Often this is not done till the following day. Cut through the print and linen with a sharp knife along the cutting-off line all around the board. Then, lifting the corner, pull gently but firmly in a slanting direction. The tacks and trimmings are then removed and the board cleared away. The case of a blueprint has been taken. Maps, drawings, etc., are done in precisely the same manner. Before the print is taken up, a coat or two of clear copal varnish is sometimes applied to preserve it still more.

Mounting Paper on Drawing Board

A quick and very satisfactory way of mounting drawing paper to the board, instead of using tacks, is resorted to by many draftsmen in the following manner: The paper is laid flat on the board, right side up. A moderate sized sponge filled with water is wiped all over the surface of the paper within an inch or so of the edge all around. The superfluous moisture is mopped up with the sponge, and the edges then dampened. One half of the sheet is turned precisely over the other half, edge for edge. With a well-filled mucilage brush go quickly around the three edges of the upturned half of sheet, and turning it over again, press the edges firmly to the board with the thumb or a flat, thin stick. Turn the other half of the sheet over the first and proceed in the same way. When thoroughly dry, the paper will stretch very satisfactorily.

Still another way of mounting paper is to lay the sheet down *wrong side* up and with a small glue brush dipped in liquid glue go all around the edge of the paper at once. Quickly sponge all over the surface with plenty of water, keeping clear of the glued edge. Having mopped up the superfluous moisture with a dry sponge, turn the paper completely over and stretch it to the board by going over the surface with the flat of the hand or a clean, dry duster, working from the center to the edges, pressing the latter all around firmly to the board with the flat of the thumb or a thin, flat stick or ruler. Either of these methods has been successfully used in many offices, especially architects', but for important work the method described under the head of "Mounting Tracing Paper," and illustrated in Fig. 29, should be resorted to.

CHAPTER III

CARD INDEX SYSTEMS

It is evident that the index system suitable for one drawing-room may not be exactly what is wanted in another, where a different product of manufacture, and different conditions in general, call for some individual modifications. It is therefore necessary to assume, perhaps, that the index systems outlined in the following may not be directly applicable to a majority of drafting-rooms, but the general principles involved will be, and ought to be, used as guides in devising any drawing-room card index system.

Index System for Drafting-Room With a Great Variety of Work *

The greatest difficulty in devising a satisfactory index system is met with in shops having to deal with a great variety of work. For drafting-rooms in shops where the product is limited to only a few

Drawing No. A-612	Date March 6 1905
Drawn by M. C-r	Checked by Potter
Casting Detail:	
	Special head for #2
Brown & Sharpe Milling Machine.	
Piece No. 656	
Remarks: For construction see A-109.	
For milling hexagon nuts.	

Fig. 31. Index Card for Shop Drawing

standard machines, or articles, which are turned out in great quantities, the problem is a comparatively easy one. But in the case where, even if the shop be comparatively small, the accumulation of drawings, sketches, patterns, and such tools as the drafting-room is often expected to take care of, becomes of a vast scope even in a few years, on account of the variety of work, a more detailed system becomes necessary.

The system indicated in the following may, at first glance, seem somewhat elaborate, but a little extra expense added in the beginning will more than repay itself in the long run. The main factor to be taken in consideration when planning a system is, of course, the rapidity with which a thing looked for can be found. The somewhat

* MACHINERY, September, 1905.

greater care needed to keep up a complete system will hardly amount to anything compared with the time wasted in trying to locate things looked for in an incomplete and patched up card index system.

The words, "drawing," "shop sketch" and "customer's sketch" referred to below are defined in this system thus:

Drawing.—Any tracing or drawing for machines, tools and devices manufactured by the firm as a standard article or used in the shop.

Shop sketch.—Any drawing, made in the drawing-room, of special tools that are ordered in small quantities by customers.

Customer's sketch.—Any drawing, tracing, sketch or blueprint that has been sent to the firm by outside parties or customers.

The drawings are indexed on cards (see Fig. 31) on which is stated:

1. Number and letter of drawing (the letter indicating the size of the drawing).
2. When made.
3. By whom made.
4. By whom checked.
5. Complete title of the drawing.
6. Piece number (if a casting, this is also the pattern number).
7. Remarks.

These cards are numbered, when they are blank, with the drawing numbers in rotation, and are kept in numerical order. As soon as a drawing is made, the first blank card is filled out and its number stamped on the drawing. The card is then placed in the index, according to the following rules: In the first place, tools and machines should be indexed in general classes, and all general attachments to the machines should be indexed under the heading of the machine with which they are used. For example, cutters of every description should be indexed under the word "Cutter," and sub-headings should be provided in the index if the number of cutters of different descriptions make a sub-division necessary. Again, for example, "Dividing head for milling machine" should be indexed under "Milling Machine" and sub-divided under "Head." Fig. 32 of an index arranged in this manner will make further explanations unnecessary.

Jigs and fixtures that are to be used for certain operations in manufacturing parts of standard machines and tools are indexed in the same divisions as the parts on which the operation is to be performed are indexed under; for example, a fixture for boring head for milling machine is indexed under "Head" for "Milling Machine." In cases where it is found difficult to decide under which heading to place a certain tool or fixture, it is advisable to make out two or even more cards under such headings where they are most likely to be looked for. The files for the cards should be kept in the most accessible place in the drafting-room, where everybody having to use them can do so with convenience.

The drawings are filed in drawers in the drawing-room, but a "record blueprint" of each ought to be kept in a fireproof safe or vault; of course one must be very particular about replacing these "record blueprints" every time a change is made on the original tracing or drawing.

Sketches, as a rule, being used only a very limited number of times, ought not to be traced, but drawn either in copying ink or copying pencil, and copied in a special copybook used for the purpose. The sketch is marked with the page number of the copybook where it is copied. These sketches could, of course, be indexed on the index pages of the copybook, but when one copybook after another is filled out it would be a waste of time to have to go through the index of each

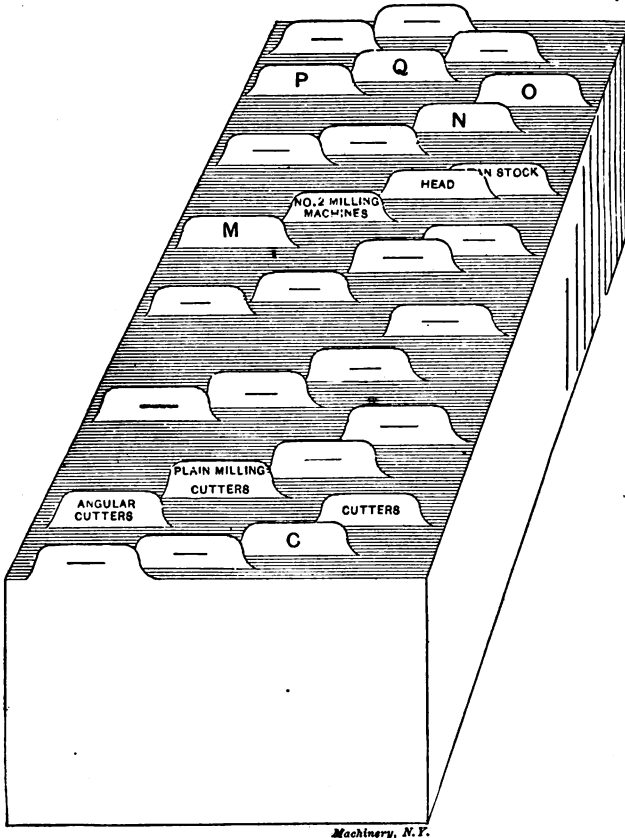

Fig. 32. Arrangement of Index Cards in File

one in order to find what is wanted; therefore a card index is provided for these sketches also, where the cards are put in order according to the names of the customer.

There is also an additional card index for these sketches where the cards are put in order, not with reference to name of customer, but according to name and kind of tool drawn on sketch. Customer's sketches are not listed in any card index, but are kept in proper order in a common letter-file.

There is no need of providing for a card index for the patterns, as

the pattern numbers are always marked, not only on the drawing itself, but also on the index card for the drawing in question. However, it is both convenient and necessary in many cases to be able to tell from the number of the pattern what machine or tool this pattern applied to; therefore a book is provided with pattern numbers in rotation, where the patterns are entered as soon as a drawing is made.

It is not only necessary to keep a good record of drawings or pat-

No. of copybook 6 Page 314 Date March 12 1905	
Drawn by G. R.	Checked by Potter
Customer's name: American Tool Works Co., Cincinnati, Ohio.	
Tool: Taper Reamer.	
Remarks: For Brass--made to their sketch.	

Fig. 33. Card in Index Arranged According to Name of Customer

terns that have been made, but equally as important to have a complete record of blueprints, sketches, patterns, etc., when in use. All blueprints given out from the drawing-room must be charged to the person for whose use it is furnished, whether he be some one in the shop or an outside party. For this purpose there is a special set of cards, one card for each drawing, this card being provided with the drawing number; these cards are kept in numerical order. When a

No of Copybook 6 Page 314 Date March 12 1905	
Drawn by G. R.	Checked by Potter
Tool: Taper Reamer.	
Customer's name: American Tool Works Co., Cincinnati, Ohio.	
Remarks: For brass--made to their sketch.	

Fig. 34. Card in Index Arranged According to Class of Tool

blue-print is given out by the drafting-room, the name of the person for whose use the blue-print was given out, is recorded on the card with the same number as the drawing. This enables anyone to find at a glance where every blueprint of a certain drawing can be found.

When sketches are sent out in the shop, it is noted in the copybook itself on corresponding page, to whom and on what date, sketch was given out. As these sketches have to go from one department to another, each department foreman is expected to keep a record of

when and to whom he sent the sketch, when he was through with it. When the work is finished, the sketch is returned to the drafting-room and the date when it was returned is noted down in the copybook on page number corresponding with sketch. Customer's sketches are never sent out in the shop, but are kept as records and for reference in the letter-file mentioned above.

A system laid out and made up in accordance with the principles above will prove itself very satisfactory, not to say necessary, for the drafting-room in a shop having a great variety of work to do.

Card Index in the Jobbing Shop *

The index system of the drafting-room in a general jobbing and repair shop also offers difficulties. The system for such a drafting-

NAME	BROWN & Co -					
ORDER NO.	NAME OF MACHINE	SIZE	HAND	MACHINE NO.	DWG NO.	
1157	HORIZONTAL ENGINE	12x12	L-H	231	52-A.	
1678	HOIST-ELECTRIC	200HP	R-H	273	12-A.	
132	BOILER-HORIZONTAL RT	48x12-0		325	46-A.	
3745	VERTICAL MARINE	42x17-0	L-H	700	722-A.	
427	SPLIT PULLEY	66x27		1172	7237-B.	
233	ROPE PULLEY & SHAFT	12-0		328	1023-C.	
3881	PORTABLE BOILER	48x12-0	R-H	7280	61-F.	
3873	BOILER-SCOTCH	36x10-0		2122	72-F.	

Fig. 35

room, as outlined below, has been devised by a man in charge of a shop doing a general line of repair work and some building of new machinery, in a place where there is little scope to take up any standard line of work or even to make the same machine twice without alteration. To avoid endless confusion, he has found it necessary to evolve some system of keeping records of the machines and parts of machines sent out, as well as of the drawings, and his experience undoubtedly will prove useful to others having to work under similar conditions.

In most shops of this kind a part of the work is done to blueprints or sketches supplied by the customer, and part to drawings made by the firm's own staff; and the patterns are sometimes the customer's property and sometimes the firm's. The remainder of the work is repairs, overhauling, refitting, etc., of which no record need be kept. The problem resolves itself into these requirements: First, to be able to find at any time the drawing to which any part of any machine was made, given the customer's name. Second, to have a complete

* MACHINERY, June, 1907.

index to all patterns, drawings, foreign blueprints, etc., to save duplication of any of these where they can be worked in on another order.

On receipt of an order from a customer it is written out on a form, a copy of which goes to the drawing office, pattern shop, boiler shop and machine shop, or such of these departments as have work to do on that order.

We will suppose that this order is for a machine to be made to the firm's own drawings. The drawing office then, on receipt of this order, makes out a production sheet on bond paper forms, giving name and number required of each part, drawing number, pattern number if a casting, and material of which it is made. This production sheet should include everything required, bolts, nuts, oil-cups, gaskets, split pins, name-plate and every detail, no matter how small. In the case

P. S. NO.	DESCRIPTION	ASSEMBLY DAS. NO.
51.	BOILER-VERTICAL - 39" x 5'-9" - 200 LBS	55A
52.	" " " " - 40" x 5'-6" - 125	20A
21.	" " " " - 42" x 7'-0" - 90	10A
5.	" " " " - 44" x 6'-7" - 125	15A
17.	" " " " - 48" x 7'-0" - 160	10A
46.	" " " " - 52" x 8'-0" - 150	49A
4.	" " " " - 60" x 9'-0" - 160	76A
33.	" " " " - 72" x 10'-0" - 140	30A
49.	" " " " - 78" x " " - 150	53A

Fig. 36

of forgings, it should give, in addition to drawing number, the length and size of bar required to make it. The required number of prints should then be made from the production sheet, and the order number, name of customer, date issued and number of machines required (the production sheet should always be made out for one machine only) put on the prints, and not on the original, as this may be used again later, on other orders. One print should then be sent to the stores department, to order the material from, and one to each of the different departments having work to do on that order, the pattern shop having to issue the patterns and orders to the foundry department. Also one print should be filed away as a record under the order number, preferably in an envelope, together with any special specification or other matter referring to that order only; these will be kept in numerical order and should be stored in a fireproof vault, but in a convenient place for reference. The original can now be altered to suit any future orders or improvements in design without affecting our record of that order. Any alterations to the drawings for subsequent orders

are also made in such a way that there is a record of the original dimensions.

Now, to duplicate any part of an old order, we have a card index of the production sheet prints that are filed under their order numbers. These cards are indexed alphabetically under the customer's name; a copy of the card is shown in Fig. 35. This card is filled out for each order for that firm and filed away in the index cabinet. Therefore, given the customer's name, we can, by consulting this index, find the order number under which his machine was built, and by getting out the production sheet print for that order number we get the drawing numbers we require.

The columns for size and hand save us the necessity of looking up two or three production sheet prints, as, for instance, if we get an order for a set of grate bars, same as supplied by us with a 48-inch

DWG. NO.	DESCRIPTION
701-B	ROPE PULLEY - 1'-4"
402-B	- 6'-0" - 2 ¹⁵ / ₁₆ BORE.
1-C	- - - 3 ¹ / ₁₆ "
111-B	- - - 4' "
1-C	- - - 4 ⁸ / ₈ "
103-B	- - - 6' "
12-C	- 12'-0" - 1 ¹ / ₄ ROPE.
23-C	- - - 1 ⁵ / ₈ "

Fig. 37

boiler for Brown & Co., we look under Brown for Brown & Co.'s card, and then down that card till we come to a 48-inch boiler, which will give us the order number, and from the production sheet print for that order number we can get the pattern number and number required. If we had not the size on the card we might have any number of boilers built by us for that firm to look up in the production sheet prints before we found the 48-inch size.

The Machine No. column is used in case a customer sells his machine to some one else, the number being stamped on the name-plate of the machine.

The Drawing No. column gives the assembly drawing number, and may save time if one wanted only an assembly drawing, but it is primarily intended for orders such as stacks, smoke connections, etc., which require only one drawing. No production sheet is made for such orders, a bill of material on the drawing giving all information required.

Limiting the Volume of the Card Index *

While the card index has proven a valuable aid in facilitating the drawing-room work, it is, however, apt to become rather voluminous if the business is a growing one, and even though one may add all the card index guides possible, dividing the index into classes and sub-divisions, there will invariably be some sub-divisions that will contain more cards than are convenient to look through every time a drawing is to be found.

For this reason a system based upon a principle of classification, as described below, will make the index less voluminous, and at the same time permit a saving of time when looking up a drawing. It is the usual practice to make one card for each drawing indexed. This is, however, not necessary as long as there will always be a certain number of drawings of the same kind of tools or articles that can conveniently be listed on the same card. The card depicted in Fig. 39 shows

CLASS Milling Machine Fixtures.				
SUBDIVISION Fixtures for parts of Multi-spindle Drills.				
FIXTURES FOR FEED RACKS.				
No. of Drawing.	Date Issued.	Draftsman..	Description.	Date Superseded
2716	6 13-1904	Smith	For 4-spindle drill, 1 $\frac{3}{8}$ center-distance.	12-31-1905
3563	9-27-1905	Leland	For 3-spindle drill, 1 $\frac{3}{8}$ center-distance.
4716	12-30-1905	Leland	For 4 spindle drill, 2 $\frac{1}{2}$ center-distance.
4719	12 31-1905	Leland	For 4-spindle drill, 1 $\frac{3}{8}$ center-distance.

Fig. 39. Index Card Adopted to Save Space

plainly the principle employed in regard to using the index guides, having first guides for general classes, and then for sub-divisions. On the third line of the card is given the general name of the class of articles for which the drawings on this card are made. The remainder of the card can be used for filling out from time to time additional drawings belonging to this same general description. It will be seen that by means of this system the card index can be easily reduced to a fraction of its original volume. As the draftsman is well aware, the average life of a drawing is rather short, and still, as superseded drawings have often to be referred to, it is well to systematize the drawing-room so that the superseded drawings are kept on file right with the regular ones, but marked "superseded," and with the date the reissue took place. In order to save unnecessary delay in looking up a drawing, the date when the drawing was superseded should also be marked on the card in the index. With the exception of these remarks, the picture of the card will explain its purpose, and

* MACHINERY, September, 1906.

its general usefulness. Systems of this character have proved a time-saving suggestion to many drawing-rooms that used to work under difficulties with rapidly expanding card-index systems.

Blue-Print Record Card *

A firm whose line of work is such that improvements and changes of designs and details are constantly being made, must by necessity devise some system of properly keeping track of the blue-prints in the factory. In an establishment where there are several hundred prints in twenty to twenty-five different departments, it is very necessary that there be some good system of keeping in touch with every blue-print, in order that the proper ones may be corrected when a change is made.

The card shown in Fig. 40 is one used to great advantage by The Garford Co., to keep track of all blue-prints issued from the drafting-

DRAWER NO.	NAME	TYPE BLUE PRINT NO.				RETURNED	REMARKS
27	CRANK SHAFT	G-4 5681					
DELIVERED	DEPT.	CONDITION	CHANGED	CHANGED	CHANGED	CHANGED	
3/120 07.	PURCH.	UNMOUNTED					
		DROP FORGE	✓	✓	✓	✓	
3/120 07.	PURCH.	UNMOUNTED	✓	✓	✓	✓	FOR ESTIMATE
		DROP FORGE	✓	✓	✓	✓	2 RUGH FING.
3/125 07.	EXPER.	UNMOUNTED	✓	✓	✓	✓	CARD. OUTSIDE
		MACHINE	✓	✓	✓	✓	
4/13 07.	PURCH.	UNMOUNTED					
		DROP FORGE	✓	✓	✓	✓	ORD. D.F. DIES.
5/1 07	10	MOUNTED	✓	✓	✓	✓	
		MACHINE	✓	✓	✓	✓	
5/1 07	12	MOUNTED	✓	✓	✓	✓	
		MACHINE	✓	✓	✓	✓	
5/3 07.	16.	MOUNTED	✓	✓	✓	✓	
		MACHINE	✓	✓	✓	✓	
5/18 07.	20.	MACHINE	✓	✓	✓	✓	

Fig. 40. Blue-Print Record Card

room. Each detail is drawn on a separate standard sheet, and mounted on pressboard for the shop. Each department has a complete book of blue-prints for each type of machine. When a change is made on a drawing, a new blue-print is made to supersede each blue-print in the factory. On issuing a blue-print from the drafting-room, a card like that in Fig. 40 is filled out. The name of the piece is entered in the place marked "Name." Blue-print number and drawer number (which is the drawer where the tracing is filed) are placed on with a stamp in their proper places. In the column marked "Delivered" the date is entered, and the department number placed in the column marked "Dep't." Under the heading "Condition," the mounting and kind of the blue-print is noted, either mounted or unmounted, machine, drop-forge or pattern drawing. For this, a rubber stamp is used. When a change is made in the tracing, by looking on the proper card.

* MACHINERY, August, 1907.

it is readily seen where the blue-prints are, and which ones are to be changed. In the column "Changed," the date when the new blue-print is delivered and the old one is returned, is noted. If for any reason it is not necessary to change the blue-print in some departments, a check or some other mark is placed in the space instead of the date, and a similar check or mark placed on the back, and the reason noted. If, for instance, the piece is a casting and some drilled hole were changed from one-quarter inch to three-eighths inch, it would not be necessary to change the blue-print in the pattern shop. Each department has its own blue-prints, and they are never delivered from one department to another without first going through the drawing-room. When a department is through with the blue-print, it is returned to the drawing-room, and the date entered in the column marked "Returned."

Card Index for the Draftsman's Individual Records *

While in the up-to-date drafting-room the card index found early acceptance, and has become a necessary adjunct for the keeping of

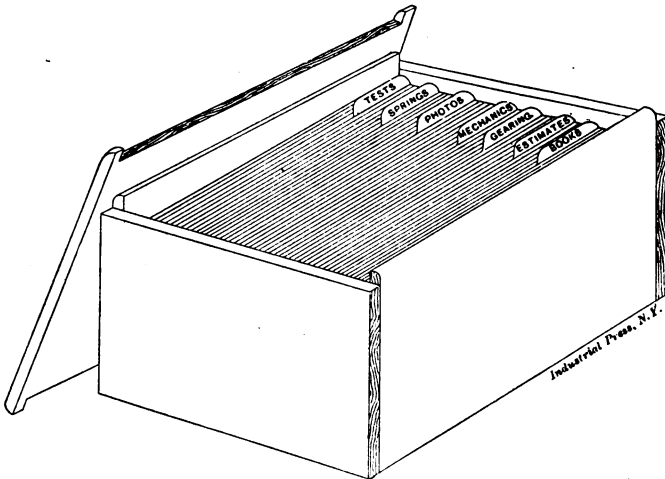

Fig. 41. Card Index for the Draftsman's Individual Records

records of various kinds, there is, however, a place in the drafting-room for the card index where it has yet to be more generally adopted, and that is as an individual adjunct to each draftsman's outfit. Years ago Nyström said: "Every engineer should make his own pocketbook, as he proceeds in study and practice, to suit his particular business," and there is no better way of compiling a pocketbook than by the use of the card index. Outfits for the purpose may be purchased in all styles and prices, from the trial outfit of 3 x 5 cards, in a pasteboard case and costing about 75 cents, up to the most elaborate cases and trays for the 5 x 8 cards.

* MACHINERY, November, 1903.

Fig. 41 is a sketch of a very cheap and serviceable index box that can be readily put together in the pattern shop, and is in some ways better suited to this particular purpose than those purchased of the regular dealers in such goods. Being made of $\frac{1}{2}$ -inch pine, planed down to about $\frac{3}{8}$ inch, it is very light and much more easily handled than the regular cases, which are usually made of oak. Another point in its favor is that it can be made much shorter than any of the regular trays which come in lengths of from 12 to 14 inches, and are, therefore, of a size that would prove unhandy upon a draftsman's board. A package containing 100 index cards of medium weight measures a little less than an inch in thickness, so that a box 4 or 5 inches deep will hold a sufficient number of cards to cover a long period of the average draftsman's experience. The object should be to compress

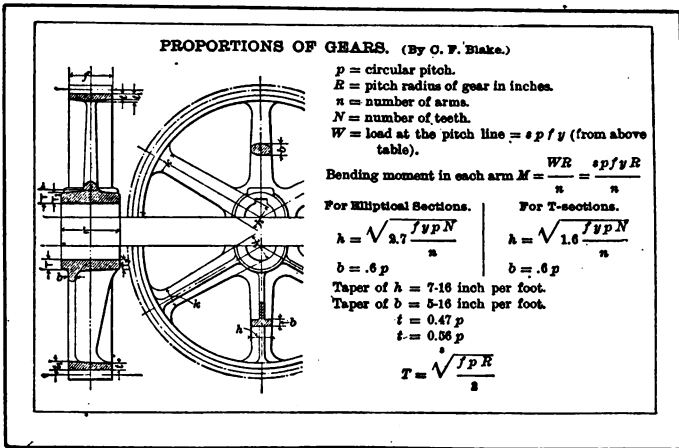

Fig. 42. The Card Index used for Clippings

the entire outfit into size and weight which shall not greatly exceed that of an ordinary reference book.

Cards for these outfits are provided mainly in 3 x 5-, 4 x 6-, and 5 x 8-inch sizes, but if the index is to be put to all of the uses which are mentioned later, the cards should not be less than the 4 x 6-inch size. Either of the two larger sizes, if used in a short, light tray, will be found fully as convenient to handle as the ordinary tray for the smaller cards when it is of the usual length and constructed of oak. The cards chosen should be of sufficient size to allow of fairly lengthy computations, and for mounting complete tables and similar data clipped from periodicals. If home-made cards are to be used they can be easily cut from manila or stiff white drawing paper, and will answer the purpose very satisfactorily. Guide cards are cut from the same material and labeled to suit the matter to be indexed. In the case illustrated no provision whatever is made for locking the cards in, as none is considered necessary. When it is desired to refer constantly to a certain card or cards they may be easily slipped out and placed

on the drawing board for the time being, and any device which makes it necessary to lock and unlock in order to do this, or to remove and add cards, will, after a short trial, be found to be more of an objection than an advantage.

The uses to which the index can be put will suggest themselves to each draftsman as the requirements of his work present them. In the first place there are certain tables to which every draftsman must constantly refer, and these should form a foundation of the index system. Such data as decimal equivalents, squares and cubes, trigonometrical functions, etc., furnish the most natural beginning. These are to be found in the handbooks in common use, such as Kent and Nyström, but when only one table is needed for a particular use, the convenience of drawing out a single card over the necessity of handling the whole book, will at once be apparent. Often several tables

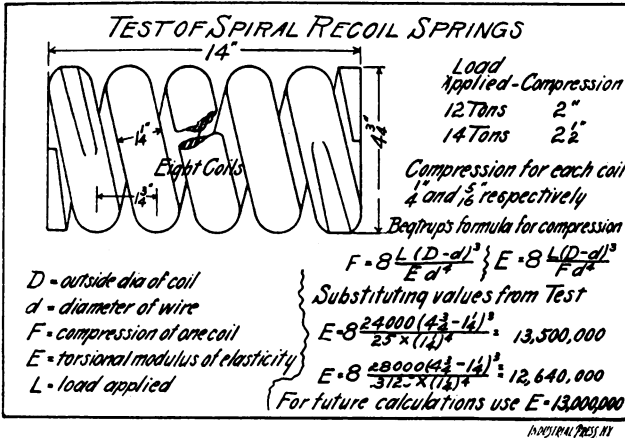

Fig. 43. The Card Index used for Record of Tests

are used at the same time, and then the pages of the book must be turned back and forth, or, perhaps, two or more books must be referred to. With the index system any number of cards may be placed side by side where the draftsman may refer to them without trouble. Having started with the tables most commonly used the index will grow with considerable rapidity. If any unfamiliar table or data is to be consulted, much time may be lost in searching for it through the different handbooks, but if, when found, it is copied on to an index card, it is then ready for immediate use if again needed. Clippings from periodicals have before been referred to, and the value of a year's subscription to any good technical publication will be wonderfully increased if all of the data that is published pertaining to one's particular line of work is placed upon the cards. Fig. 42 is an illustration of a data card upon which is mounted one of the tables taken from a MACHINERY data sheet.

Reviews of all technical books that the owner reads should find a

place upon these cards. To thoroughly digest any book there is no better plan than to make notes and extracts as the reader proceeds, and if these are afterward placed in his index, they will often prove of the greatest value.

In many drawing-rooms the draftsman is provided with a note book in which to record all calculations, estimates, and other computations that may arise in connection with his work. After one of these books has been in use for several months, and a mass of calculations has accumulated therein, it is a most tedious job to search them over for the figures applying to the matter in hand. If, however, the calculations are made upon index cards and filed under appropriate headings, they may be found at a minute's notice.

A draftsman is often called upon to design certain pieces of mechanism in which the strength of the material must be taken from general

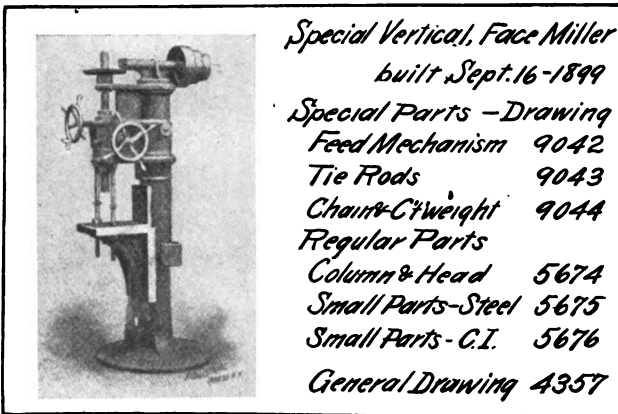

INDUSTRIAL PRESS, N.Y.

Fig. 44. The Card Index used for Record of Special Machines

data and may vary considerably from the strength of the material actually used. In such a case it may be practical to make subsequent tests and from these to obtain definite data. The card shown in Fig. 43 is taken from an index compiled by a designer for the purpose of recording such data, and serves to illustrate the way in which the results of such tests can be kept for ready reference. The problem in this case was to design a spring that should stand a load of about 25,000 pounds and to determine its deflection when loaded. The spring was designed and the compression figured by Begtrup's formulas, in which the modulus of elasticity is given as from 10,000,000 to 14,000,000, and the exact modulus to be used is left to the judgment of the designer. After these springs were made they were tested, with the results shown on the card, and substituting the actual deflection for given loads we are able to determine a modulus of elasticity, in this case about 13,000,000, which can be regarded as comparatively exact data for use in designing springs that are to be made of the same

material and to perform similar duty. If similar comparisons be made of castings and forgings of various kinds, we soon accumulate a quantity of very reliable information that applies more closely to our particular cases than any published data which must, at best, be only general in its nature.

Photographs of machines built, and data connected with them, will prove valuable additions to the index. Fig. 44 shows a record of a special vertical milling machine, and explains just which parts were special and which regular, and provides a complete record of the drawings used and any information that would be of aid to the draftsman if called upon to design a similar machine at some future time.

