

MACHINERY'S REFERENCE SERIES

EACH NUMBER IS A UNIT IN A SERIES ON ELECTRICAL AND
STEAM ENGINEERING DRAWING AND MACHINE
DESIGN AND SHOP PRACTICE

NUMBER 105

AUTOMATIC SCREW MACHINE PRACTICE

PART VII

KNURLING OPERATIONS ON THE BROWN & SHARPE
AUTOMATIC SCREW MACHINES

By DOUGLAS T. HAMILTON

CONTENTS

Cross-slide Knurling Operations	- - - - -	3
Turret Knurling Operations	- - - - -	19
Special Knurling Operations	- - - - -	33



CHAPTER I

CROSS-SLIDE KNURLING OPERATIONS

In designing a set of cams for knurling operations on the Brown & Sharpe automatic screw machines, it is desirable that as little experimental work as possible be required. The following formulas and data will prove of value in this connection. Before presenting these data and formulas, however, the different tools and appliances necessary for knurling will be briefly reviewed.

A very solid and rigid rear cross-slide knurl-holder is shown in Fig. 1. It is held by means of the cap-screw *B* on the outside face *A* of the cross-slide tool-holder. This screw also holds the circular cut-off tool in position. The holder allows the knurl to pass over the work, and re-

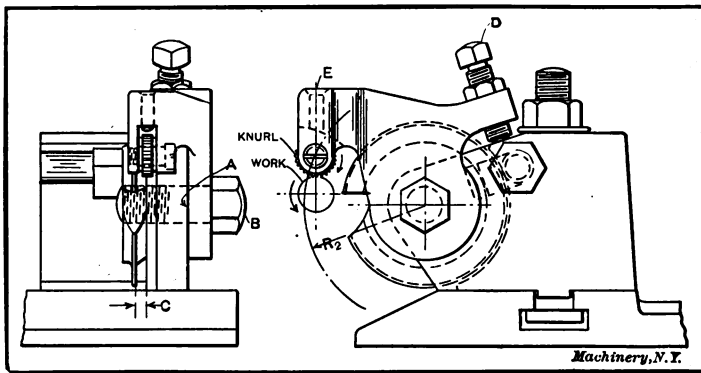

Fig. 1. Rear Cross-slide Knurl-holder

turns it after the piece has been cut off. It is simple and cheap, and covers a wide range of work, as the distance *C* to the circular cut-off tool can be changed so that the work will be cut off closer or further away from the knurl, as desired. The set-screw *D* rigidly supports the knurl-holder, and also provides means for adjusting. The oil hole *E* permits a good supply of oil to reach the knurl for removing all chips. This holder, however, can be used only on the tool-holder which carries the cut-off tool, because the finished piece must be severed from the bar before the knurl can return.

Universal Cross-slide Knurl-holder

The knurl-holder shown in Fig. 1 is limited in its range, but the one shown in Fig. 2, while more expensive and complicated, is also more efficient and universal. This holder eliminates the cross-slide tool-post, and carries the circular cut-off tool *A* in the same way as it would be held in the ordinary tool-post. It can also be used in conjunction with either circular form or cut-off tools on the front cross-slide. The knurl

can operate at any desired position on the work by moving the arm *C* along the bar *D* and then clamping it by means of the cap screw *E*. The holder *F* which carries the knurl can be moved in or out to any position to suit the different diameters of stock being knurled, and is adjusted by means of adjusting nuts *H* and *J*. The nut *G* is adjusted to insure a good working fit of the holder, and also prevents side movements. When the knurl passes over the stock the nut *H* is brought up against the face *B* of the arm *C*, and also puts a tension on spring *K*,

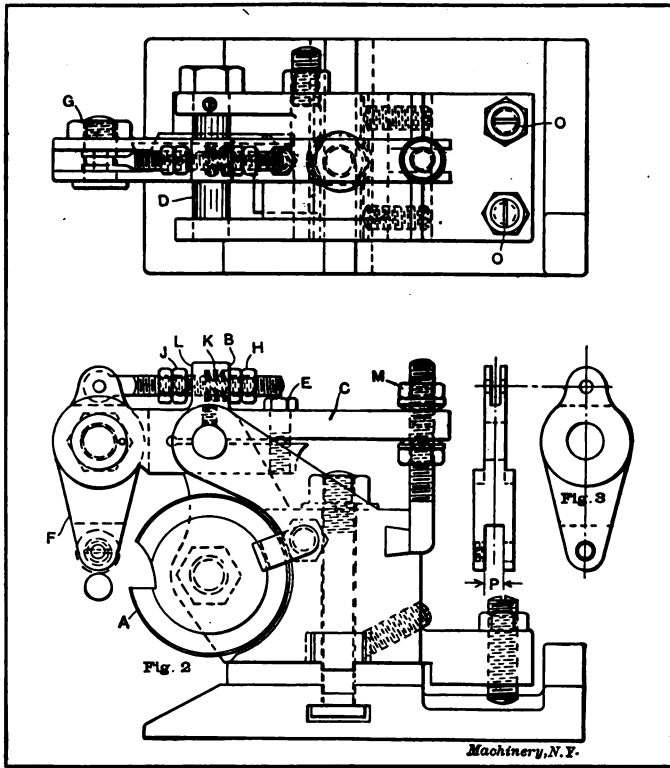

Figs. 2 and 3. Universal Cross-slide Knurl-holder

so that when the knurl has passed over the work and the pressure on the spring is released, the spring forces the nut *J* up against the face *L* and permits the knurl to clear the work when passing back over the stock. The nuts *M* permit the arm *C* to be raised or lowered for different diameters of stock. The washers are convex, as shown, so that the arm is held firmly even when at an angle to the face of the nuts *M*. Screws *O* tend to steady the holder.

In Fig. 3 the knurl-holder proper is shown in detail. It will be seen that knurls of different widths may be used by making the distance *P* to suit.

Straight Knurls

Straight knurls, as shown in Fig. 4, are generally cut in the milling machine with a cutter of the desired angle. The greatest difficulty is met with in selecting a suitable angle for the teeth for knurling different materials. A blunt knurl will work better on soft materials than one with a more acute angle. The following angles are satisfactory for the materials specified below:

- Brass and hard copper.....90 degrees.
- Gun screw iron80 degrees.
- Norway iron and machine steel.....70 degrees.
- Drill rod and tool steel.....60 degrees.

When laying out a set of cams for knurling operations, it is necessary to know the depth of the tooth in the knurl.

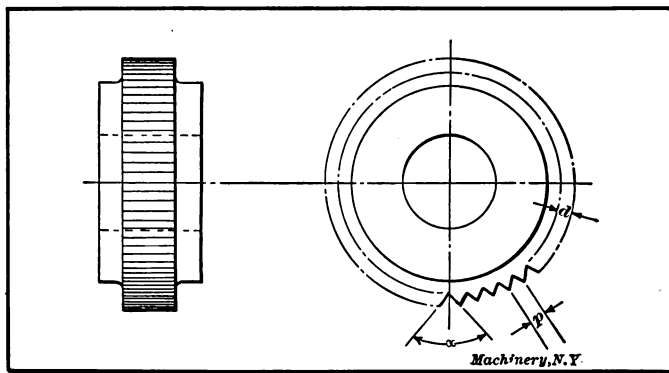

Fig. 4. Straight Knurl

- If d = depth of tooth in knurl,
- p = circular pitch of knurl,
- P = "pitch of knurl" = number of teeth in one inch of the circumference = $\frac{1}{p}$,
- a = included tooth angle of knurl,

then, for all practical purposes, the depth may be calculated as follows:

When

$$a = 90 \text{ degrees, } d = \frac{p}{2},$$

$$a = 80 \text{ degrees, } d = \frac{p}{2} \times \tan 50 \text{ degrees,}$$

$$a = 70 \text{ degrees, } d = \frac{p}{2} \times \tan 55 \text{ degrees,}$$

$$a = 60 \text{ degrees, } d = \frac{p}{2} \times \tan 60 \text{ degrees.}$$

The values of d for different pitches ranging from 16 to 62 teeth per inch of circumference have been calculated from these formulas and are given in Table I.

Concave Knurls

The designing of a concave knurl which will work satisfactorily is, in most cases, a difficult problem, as the radius of the knurl cannot have the same radius as the piece to be knurled. It will be seen in Fig. 5 that if the knurl and the work are of the same radius, the material compressed by the knurl will be forced down on the shoulder A

TABLE I. DEPTH OF TEETH IN KNURLS

P = number of teeth in one inch of circumference p = circular pitch a = included angle of tooth d = depth of tooth					
P	p	$a = 90^\circ$	$a = 80^\circ$	$a = 70^\circ$	$a = 60^\circ$
		d	d	d	d
16	0.0625	0.0812	0.0871	0.0445	0.0540
18	0.0555	0.0277	0.0330	0.0395	0.0480
20	0.0500	0.0250	0.0297	0.0357	0.0438
22	0.0454	0.0227	0.0260	0.0324	0.0398
24	0.0416	0.0208	0.0247	0.0297	0.0360
26	0.0384	0.0192	0.0228	0.0274	0.0332
28	0.0357	0.0178	0.0212	0.0254	0.0308
30	0.0333	0.0166	0.0199	0.0237	0.0287
32	0.0312	0.0156	0.0185	0.0222	0.0270
34	0.0294	0.0147	0.0175	0.0209	0.0254
36	0.0277	0.0138	0.0164	0.0197	0.0239
38	0.0263	0.0131	0.0156	0.0187	0.0226
40	0.0250	0.0125	0.0148	0.0178	0.0216
42	0.0238	0.0119	0.0142	0.0169	0.0206
44	0.0227	0.0113	0.0134	0.0161	0.0195
46	0.0217	0.0108	0.0128	0.0154	0.0187
48	0.0208	0.0104	0.0124	0.0148	0.0180
50	0.0200	0.0100	0.0119	0.0142	0.0173
52	0.0192	0.0096	0.0114	0.0137	0.0166
54	0.0185	0.0092	0.0109	0.0131	0.0159
56	0.0178	0.0089	0.0106	0.0127	0.0154
58	0.0172	0.0086	0.0102	0.0122	0.0148
60	0.0166	0.0083	0.0099	0.0118	0.0143
62	0.0161	0.0080	0.0096	0.0114	0.0138

and will consequently make a poor looking job. The writer, having met with this difficulty, devised an empirical formula which gives satisfactory results.

A design of a concave knurl is shown in Fig. 6, and all the important dimensions are designated by letters. To find these dimensions, the pitch of the knurl required must be known, and also, approximately, the throat diameter B . This diameter, of course, must suit the knurl holder used, and be such that the circumference contains an even number of teeth with the required pitch. When these dimensions have been decided upon all the other unknown factors can be found from the formulas given in the following.

- Let R = radius of piece to be knurled,
 r = radius of concave part of knurl,
 C = radius of cutter or hob for cutting the teeth in the knurl,
 B = diameter over concave part of knurl (throat diameter),
 A = outside diameter of knurl,
 d = depth of tooth in knurl,
 P = pitch of knurl (number of teeth per inch circumference),
 p = circular pitch of knurl.

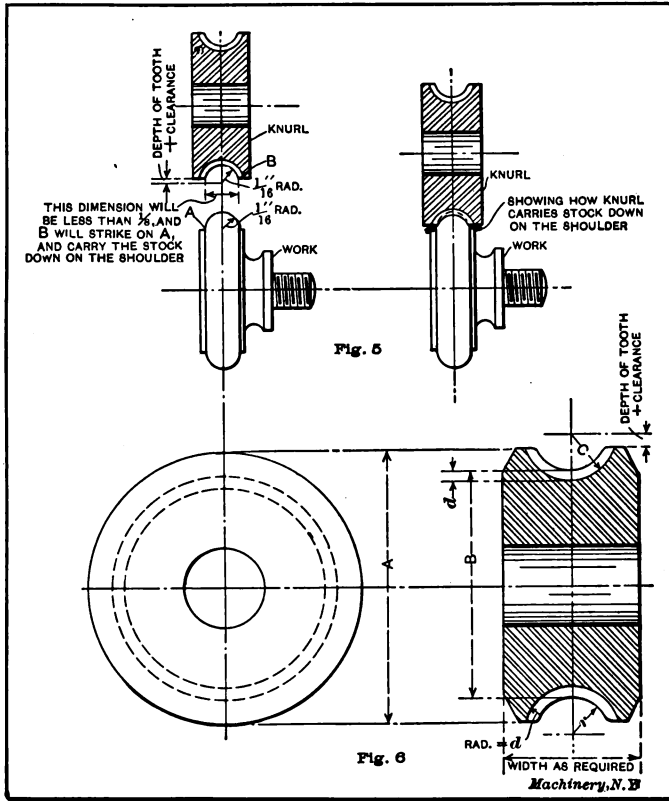

Figs. 5 and 6. Concave Knurls

$$\begin{aligned} \text{Then, } r &= R + \frac{1}{2} d, \\ C &= r + d, \\ A &= B + 2r - 3d + 0.010 \text{ inch.} \end{aligned}$$

As the depth of the tooth is very slight, the outside circumference will be accurate enough for all practical purposes for calculating the pitch, and it is not necessary to take into consideration the pitch circle as is done when calculating gears.

Example:—Assume that the pitch of a knurl is 32, that the throat diameter B is 0.5561 inch, that the radius R of the piece to be knurled

is $1/16$ inch, and that the angle of the teeth is 90 degrees; find the dimensions required for making the knurl.

Using the same notation as above, we have:

$$p = \frac{1}{P} = \frac{1}{32} = 0.03125 \text{ inch,}$$

$$d = 0.0156 \text{ inch (see Table I),}$$

$$r = \frac{1}{16} + \frac{0.0156}{2} = 0.0703 \text{ inch,}$$

$$C = 0.0703 + 0.0156 = 0.0859 \text{ inch,}$$

$$A = 0.5561 + 0.1406 - 0.0468 - 0.010 = 0.6399 \text{ inch.}$$

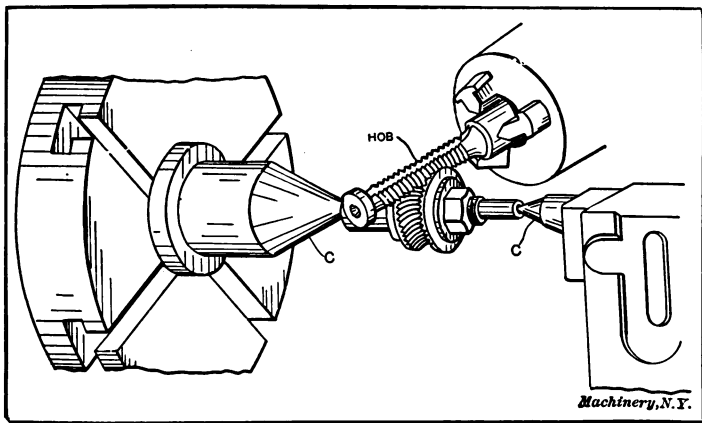

Fig. 7. Cutting a Concave Knurl by a Hob in the Milling Machine

Straight concave knurls, when very small, are generally made with a master convex knurl. When the knurls are large enough, a milling cutter with the proper radius is used for cutting the teeth. As it is very difficult to make a concave knurl when the radius is very small, and as the knurl in most cases is not required to be absolutely straight, the method described in the following for spiral knurls can be used for making straight concave knurls on the milling machine with teeth in planes practically parallel with the axis of the knurl.

Spiral Concave Knurls

It is, in general, very difficult to cut spiral concave knurls, especially when the radius of the knurl is very small. In Fig. 7 is shown a method which has worked very satisfactorily, and which is also easily accomplished. A hob as shown in Fig. 8 is used, the included angle of the threads of which is made to suit the material to be knurled. The hob is fluted similarly to a master tap, except that the flutes are not as deep and a greater number of flutes is used. The lead of the hob governs the angle of the spiral on the knurl, and the angle formed by cutting hobs with different leads can be derived, approximately, by means of the following formula:

Let a = angle required,
 B = one-half the lead of the thread of the hob,
 D = diameter of the hob.

$$\text{Then } \frac{B}{1.5 D} = \tan a.$$

Example:—If a hob has a double thread, the lead of which is $\frac{1}{8}$ inch, and the diameter of the hob is $\frac{1}{4}$ inch, find the angle a .

$B = \frac{1}{2}$ of the lead = $\frac{1}{16}$, and, therefore, $\tan a = \frac{1}{16} \div \frac{3}{8} = 0.1667$; $a = 9\frac{1}{2}$ degrees.

Cutting a Spiral Concave Knurl in the Milling Machine

It will be seen from Fig. 7 that when cutting a concave knurl in the milling machine, the knurl is held on an arbor shown in detail in Fig.

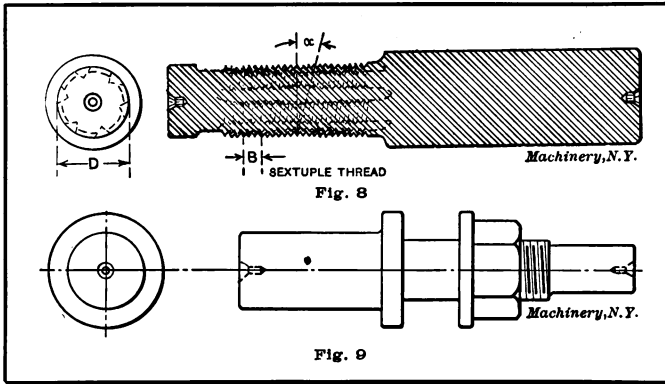

Fig. 8. Hob used for Cutting Concave Knurls in the Milling Machine
 Fig. 9. Arbor for Cutting Concave Knurls in the Milling Machine

9. This arbor rotates freely on the centers C , the knurl being held tightly against the shoulder on the arbor by the nut shown. When the knurl has been tightened, the arbor is put between the centers and the table of the milling machine is raised so that the hob comes in contact with the knurl. The machine runs slowly at the start so that the hob will not be forced, but will space the teeth equally. The speed can be increased after the hob has started to cut properly. The hob is held in a chuck provided with a shank fitting the socket in the milling machine spindle. The work should be fed slowly at first, and care should be taken that the arbor rotates freely on the centers, as otherwise the knurl will not follow the lead of the hob properly, and a well-shaped tooth will not be produced. Care should also be taken to have the diameter of the concave knurl the correct size so that it will contain an even number of teeth, as required by the circular pitch. When the knurl has been cut, the corners should be removed as shown in Fig. 6; then no ragged edges are left on the work, as is the case if the corners are not removed. The table of the milling machine should not be set over when cutting knurls in this manner, but should be left straight.

Designing and Cutting Diamond Knurls

The general methods of using diamond knurls are as follows:

1. When a knurl-holder, as shown in Fig. 10, can be used, a pair of spiral knurls are used, one right- and one left-hand.
2. When a cross-slide knurl-holder, as shown in Fig. 1, is used, only one knurl can be used, being cut both right- and left-hand. A knurl cut in this manner would produce a female knurl on the work; so if a male knurl is required on the work, the first knurl is used as a master knurl in cutting the second knurl which will produce a male knurl on the work.

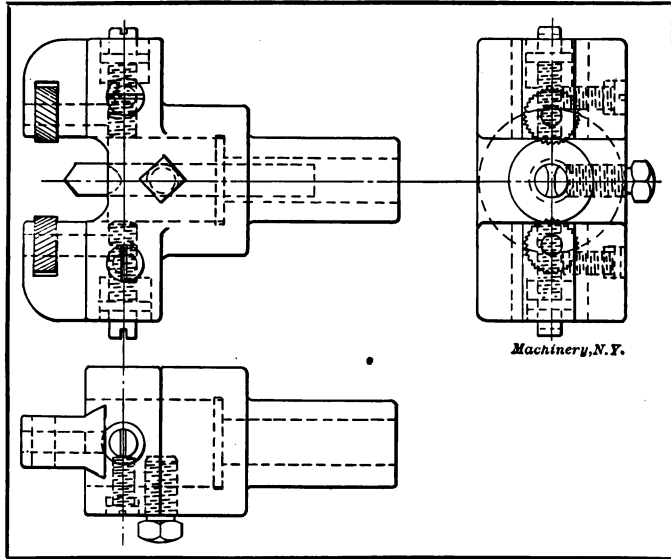

Fig. 10. Turret Knurl-holder for Brown & Sharpe Automatic Screw Machines

When only the pitch of the knurl required and the angle at which the teeth are cut, as indicated in Fig. 11, are known, then the number of teeth in the knurl must be found and also the spiral lead, as this governs the selection of the change gears used when cutting the knurl.

To Find the Number of Teeth on the Circumference of the Knurl

When the knurl is to form diamond shapes, as shown in Fig. 11, and the included angle is 60 degrees, the number of teeth can be found in the following manner. Let 22 be the normal pitch of the knurl. Then the circular pitch will be $0.0455 \text{ inch} \div \cos 30 \text{ degrees} = 0.0525 \text{ inch}$, and the outside circumference divided by 0.0525 inch will be the number of teeth of the knurl.

To Find the Lead of the Spiral

To find the lead of a spiral of the knurl mentioned multiply the circumference of the knurl by the cotangent of 30 degrees. Assume

that the knurl is 0.752 inch in diameter. Then the circumference equals $0.752 \times 3.1416 = 2.3625$ inches. The knurl has a circular pitch of 0.0525 inch, and the number of teeth therefore equals $2.3625 \div 0.0525 = 45$ teeth. The lead equals $2.3625 \times \cot 30 \text{ degrees} = 4.09$ inches.

Speeds and Feeds for Knurling

When the knurl has been designed, the next thing to consider, before laying out the cams, is the speed and feed for knurling. This is a subject upon which very little has ever been published. As a general rule, a knurl can be worked at the same speed as the circular form and cut-off tools. It is good practice to feed the knurl gradually to the center of the work, starting to feed where the knurl touches the

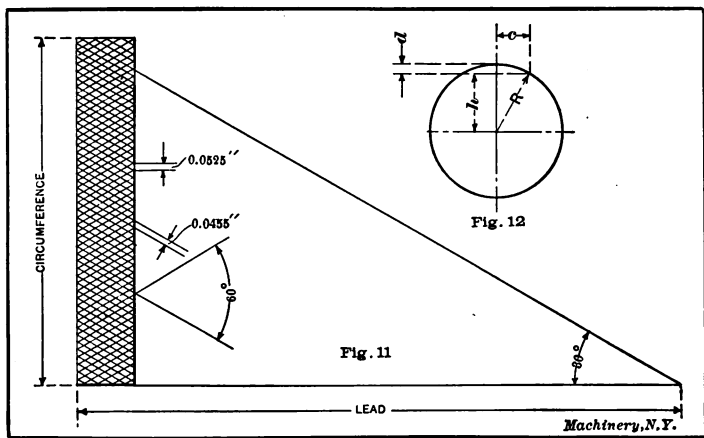

Fig. 11. Diagram for Finding Circular Pitch and Lead of Spiral Knurls
Fig. 12. Diagram for Calculations Relating to the Feeds of Knurls

work as is shown by the distance c in Fig. 12, and then to pass off the center of the work with a quick rise on the cam. The knurl should also dwell for a certain number of revolutions, depending on its pitch, and the nature of the material being worked upon. Some advocate the knurl being brought into position on the center of the work on the quick rise of the cam, and then being allowed to dwell for a certain number of revolutions; but the writer has found that this does not work satisfactorily, and cannot be depended upon. It might work when using a knurl which has a very fine pitch, on large stock, but under general conditions it will be found that gradually feeding the knurl to the center of the work will work better.

The feed required for a knurl is governed by the nature of the material being knurled, the diameter of the material, and the width and pitch of the knurl.

The surest and most practical way to find the feed required for a knurl on a certain kind of material is by experimenting. The writer has collected the results of different experiments and compiled them in Table II. This table covers practically all the different materials

specified in this article, as the angle of the teeth in the knurls varies in accordance with the hardness of the material on which the knurl is used. In that case the feeds given in the table will be practically the same for all the materials previously specified. These feeds are only applicable when knurling from the cross-slide.

TABLE II. FEEDS FOR KNURLING

Diam. of Stock, Inches	Width of Knurl, Inches							
	$\frac{1}{8}$	$\frac{1}{4}$	$\frac{3}{8}$	$\frac{1}{2}$	$\frac{5}{8}$	$\frac{3}{4}$	$\frac{7}{8}$	1
	Feed per Revolution, Inches							
$\frac{1}{16}$	0.0010	0.0005
$\frac{1}{8}$	0.0014	0.0009	0.0005
$\frac{3}{16}$	0.0018	0.0012	0.0010	0.0005
$\frac{1}{4}$	0.0022	0.0016	0.0014	0.0010	0.0005
$\frac{5}{16}$	0.0026	0.0020	0.0018	0.0013	0.0010	0.0005
$\frac{3}{8}$	0.0030	0.0025	0.0023	0.0017	0.0015	0.0010	0.0005
$\frac{7}{16}$	0.0034	0.0029	0.0026	0.0021	0.0018	0.0015	0.0010	0.0005
$\frac{1}{2}$	0.0039	0.0032	0.0030	0.0025	0.0022	0.0020	0.0014	0.0008
$\frac{5}{8}$	0.0042	0.0036	0.0034	0.0029	0.0028	0.0024	0.0017	0.0012
$\frac{3}{4}$	0.0046	0.0040	0.0038	0.0033	0.0031	0.0028	0.0020	0.0016
$\frac{7}{8}$	0.0050	0.0045	0.0042	0.0037	0.0034	0.0031	0.0023	0.0020
1	0.0054	0.0049	0.0048	0.0041	0.0038	0.0034	0.0026	0.0023
$\frac{1}{16}$	0.0059	0.0052	0.0052	0.0045	0.0042	0.0037	0.0029	0.0026
$\frac{1}{8}$	0.0062	0.0058	0.0055	0.0049	0.0045	0.0040	0.0033	0.0029
$\frac{3}{16}$	0.0068	0.0062	0.0058	0.0052	0.0048	0.0042	0.0037	0.0032
$\frac{1}{4}$	0.0070	0.0065	0.0060	0.0055	0.0050	0.0045	0.0040	0.0035

Under these conditions the depth of the tooth and the feed per revolution will govern the number of revolutions required to knurl. If in Fig. 12, R is the radius of the stock, d is the depth of the tooth, c is the distance the knurl travels at a given feed per revolution, and h equals $R - d$, then $c = \sqrt{R^2 - (R - d)^2}$.

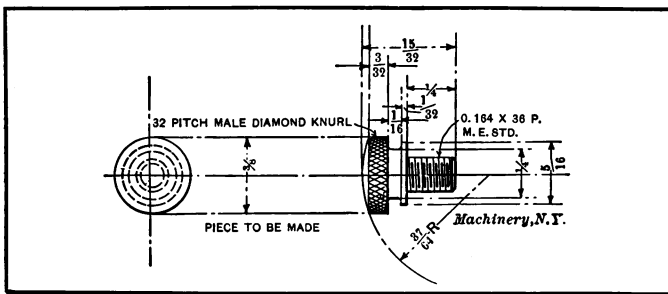

Fig. 13. Thumb-screw to be Knurled

Let $R = 0.125$ inch and $d = 0.0164$ inch; then $h = 0.1086$ inch. Therefore $c = \sqrt{0.125^2 - 0.1086^2} = 0.062$ inch = rise required.

Revolutions Required to Knurl

Assume that it is required to find the number of revolutions to knurl a piece of gun screw iron, $\frac{1}{4}$ inch in diameter, with a knurl $\frac{1}{8}$ inch

TABLE III. DIMENSION A, FIG. 15, FOR DIFFERENT ANGLES OF CUT-OFF TOOLS

Thickness of Tool	$\beta = 10$ deg.		$\beta = 15$ deg.		$\beta = 18$ deg.		$\beta = 20$ deg.		$\beta = 23$ deg.	
	A	2 A	A	2 A	A	2 A	A	2 A	A	2 A
	0.080	0.0052	0.0105	0.0080	0.0160	0.0097	0.0195	0.0109	0.0218	0.0127
0.085	0.0061	0.0123	0.0093	0.0187	0.0118	0.0227	0.0127	0.0255	0.0148	0.0296
0.040	0.0070	0.0140	0.0107	0.0214	0.0130	0.0260	0.0145	0.0291	0.0169	0.0339
0.045	0.0079	0.0158	0.0120	0.0241	0.0146	0.0292	0.0163	0.0327	0.0190	0.0381
0.050	0.0088	0.0176	0.0134	0.0268	0.0162	0.0325	0.0182	0.0364	0.0212	0.0424
0.055	0.0096	0.0193	0.0147	0.0294	0.0178	0.0357	0.0200	0.0400	0.0233	0.0466
0.060	0.0105	0.0211	0.0160	0.0321	0.0195	0.0390	0.0218	0.0436	0.0254	0.0508
0.065	0.0114	0.0228	0.0174	0.0348	0.0211	0.0422	0.0236	0.0473	0.0275	0.0551
0.070	0.0123	0.0246	0.0187	0.0374	0.0227	0.0455	0.0254	0.0509	0.0296	0.0598
0.080	0.0140	0.0281	0.0214	0.0428	0.0260	0.0520	0.0291	0.0582	0.0339	0.0678
0.090	0.0158	0.0316	0.0241	0.0483	0.0292	0.0585	0.0327	0.0655	0.0381	0.0763
0.100	0.0176	0.0352	0.0268	0.0536	0.0325	0.0650	0.0364	0.0728	0.0424	0.0848
0.110	0.0193	0.0387	0.0294	0.0589	0.0357	0.0715	0.0400	0.0800	0.0466	0.0932
0.115	0.0202	0.0404	0.0308	0.0616	0.0378	0.0747	0.0418	0.0837	0.0487	0.0975
0.120	0.0211	0.0422	0.0321	0.0643	0.0390	0.0780	0.0436	0.0873	0.0508	0.1017
0.125	0.0220	0.0440	0.0335	0.0670	0.0406	0.0812	0.0455	0.0910	0.0530	0.1060

wide of 36 pitch. The included angle of the tooth for gun-
screw iron is 80 degrees. The circular pitch is 0.277, and,
referring to Table I, the depth of the tooth is 0.0164; the
distance c, as worked out in the previous example, is 0.062
inch. Then, referring to Table II, the feed per revolution
for a knurl 1/8 inch wide, knurling on 1/4-inch stock, is
0.0016 inch per revolution. Therefore, total revolutions
required = 0.062 ÷ 0.0016 = 38.7 or, approximately, 39
revolutions. In some cases the feeds given in Table
Fig. 1,

II can be increased 50 per cent. and still give good
results.
Let us now assume an example of a knurling opera-
tion on the No. 0 Brown & Sharpe automatic screw
machine, and find the principal dimensions of the cam
for performing same. A thumb-screw, as is shown at
Fig. 13, is to be knurled with a 32-pitch knurl, 1/8 inch
wide, using a cross-slide knurl-holder as shown in
Fig. 1,

Total Rise on Cam

It is required to find the total rise on the cam to complete the knurling, and also to cut the finished piece from the bar. The total rise can be found by means of the following formulas, derived by the aid of the diagram in Fig. 15. This shows the knurl in position on the center of the work, and the circular cut-off tool is also shown in its relative position to the work and the knurl.

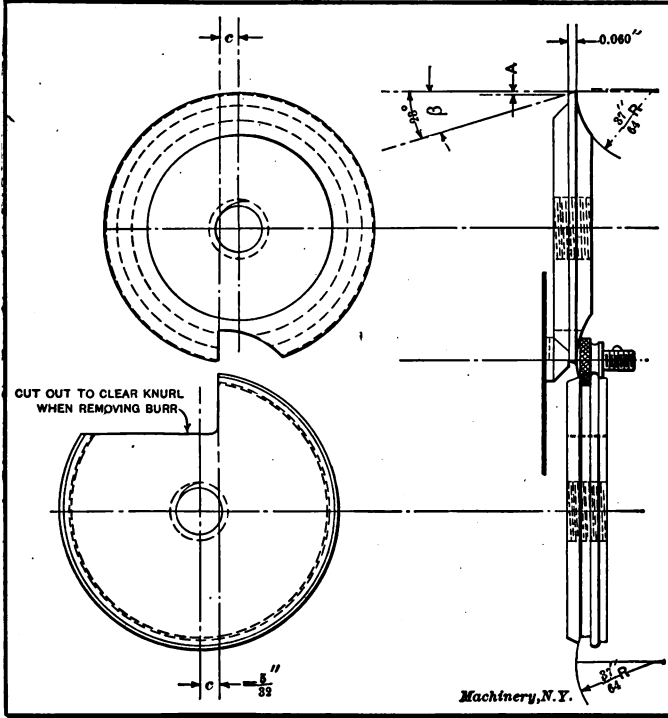

Fig. 14. Circular Forming and Cut-off Tools for Making Thumb-screw shown in Fig. 13

- Let T = total rise on the cam,
 N = rise required to knurl,
 S = radius of stock to be cut off,
 A = distance of bevel on cut-off tool as given in Table III,
 C = total rise required to cut-off = $S + 0.010$ inch (to approach) +
 0.005 inch (to pass center of stock) + A ,
 E = distance from center of circular tool to edge as shown, when
 tool is cut down below the center,
 a = radius of knurl to outside diameter,
 b = radius of stock minus depth of tooth in knurl,
 c = distance from cutting face to center of circular tool,
 $h = a + b + c$,
 X = distance from center of cut-off tool to center of knurl, when
 it is in position on the center of the stock,

R = radius of stock,
 r = radius of knurl,
 R_1 = radius of cut-off tool,
 R_2 = radius of knurl holder shown in Fig. 1,
 F = distance between the knurling and cut-off operations. Then
 $E = \sqrt{R_1^2 - c^2}$; $X = \sqrt{R_2^2 - h^2}$;
 $N = \sqrt{R^2 - (R-d)^2}$ (See Fig. 12).

$$F = X - (S + E); T = N + F + C,$$

For example, let it be required to design a set of cams to make the thumb-screw shown in Fig. 13, the material being $\frac{3}{8}$ -inch round brass rod, and on which is cut a 32-pitch knurl. For the knurling operation we will use a cross-slide knurl-holder, as shown in Fig. 1. R is 0.1875

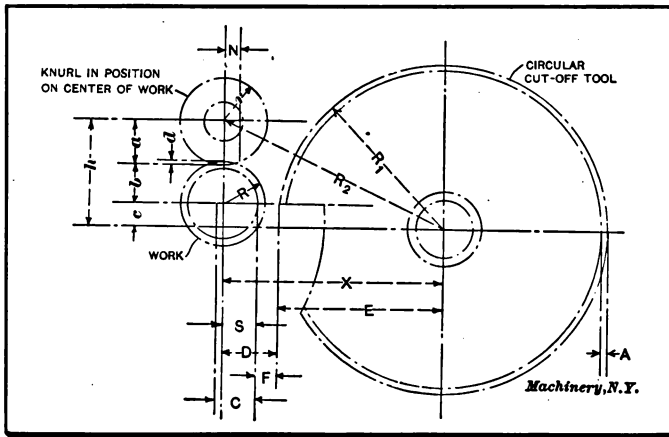

Fig. 15. Diagram for Finding Total Rise of Cam for Knurling Operation

inch, r is 0.375 inch, R_1 is 1.125 inch, R_2 is 1.625 inch; d is 0.0156 inch, angle on cut-off tool is 23 degrees, and the width of the cut-off tool is 0.060 inch; then, referring to Table III, A is 0.0254 inch. The cut down below the center on the circular tool c is $\frac{5}{32}$ inch. Then, $a = 0.375$; $b = 0.1875 - 0.0156 = 0.1719$; $c = 0.1562$; $h = 0.7031$.

$$E = \sqrt{(1.125^2 - 0.1562^2)} = 1.114,$$

$$X = \sqrt{(1.625^2 - 0.7031^2)} = 1.465,$$

$$N = \sqrt{0.1875^2 - (0.1875 - 0.0156)^2} = 0.075,$$

$S = 0.1562$ inch, which is the radius of the shoulder left by the circular form-tool,

$$C = 0.1562 + 0.010 + 0.005 + 0.0254 = 0.1966,$$

$$F = 1.465 - (0.1562 + 1.114) = 0.1948,$$

$$T = 0.075 + 0.1948 + 0.1966 = 0.4664 \text{ inch, which is the total rise required on the cam, for the knurling and the cut-off operations.}$$

Having determined the total rise required on the cam, we will consider briefly the other operations. The order of the various operations

is given in the layout chart on page 20, and the position and type of tools used in the turret are shown in Fig. 16. As all the various operations are shown plainly on the chart very little explanation will be required.

Before starting to design the cams, the drawings of the tools suitable for performing the various operations are collected, using standard tools as much as possible. Then, after selecting the various tools, a lay-out of the circular form and cut-off tools, as shown at Fig. 14, is made. After having drawn the circular tools, and also laid out the turret operations as shown in Fig. 16, the order of the various opera-

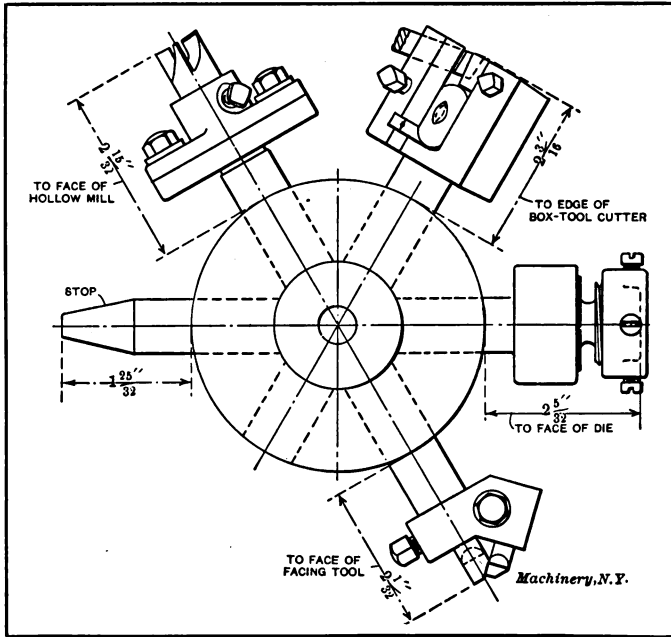

Fig. 16. Arrangement of Tools in the Turret

tions is considered. Referring to the plan of operations shown in the chart, the work proceeds in the following order: Feed stock to stop and chuck, revolve turret, and rough turn with the hollow mill shown in Fig. 16; while the hollow mill is turning down the work, the circular form tool is brought in and forms the head; the form tool retreats so that it will clear the face of the hollow mill; then the turret is revolved and the finishing box-tool turns down the portion which is to be threaded. Now the turret is revolved and the die-holder is brought into position, and the work is threaded. By referring to Fig. 20, it will be seen that the highest portion of the lobe for the die is cut down equal to two threads, or 0.0554; this allows the die holder to draw out, and the spindle reverses on the tension of the spring (when a draw die-holder is used), which makes the die work easier, and does not

crowd it on the work. After the die comes off the work, clearance is allowed between the knurling tool and the die holder, which should be ample so that the tools will not come in contact with each other. Then the knurl travels onto the work, and dwells for 0.01 of the circumference (which in this case is equal to 4.2 revolutions of the spindle), when on the center of the work. It is then forced off the work by the rise shown in Fig. 20, on the back cam. The circular form tool is now brought in again and removes the burr thrown up by the knurl; the form tool is cut away to clear the knurl. Finally, the back cross-slide travels in, and the circular cut-off tool shown in Fig. 14 starts to cut off the piece, but while the piece is being cut off, the pointing tool shown in Fig. 16 is brought in and removes the burr that has been

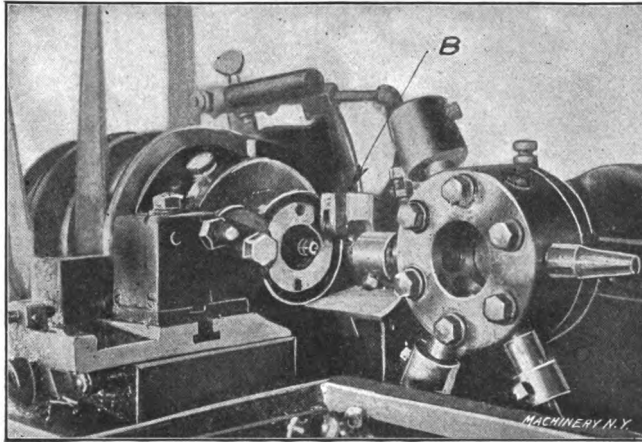

Fig. 17. Machine set up and ready for Making Thumb-nuts

thrown up by the die on the end of the screw; the piece is then severed from the bar, and clearance is allowed to let the cut-off tool return before the stock is fed out again.

Cutting the Cams

After the cam blanks have been laid out, they are roughed out by drilling a series of holes about 1/8 inch or 3/16 inch away from the finishing line or by punching, which is performed on an ordinary punch-press. Then the cam is put onto a circular milling attachment. A vertical milling attachment is used in connection with the circular attachment, and a mill of the required diameter, which depends on the size of the roll on the automatic screw machine, is used for cutting the cam. The circular attachment is graduated in degrees and minutes, and it is, therefore, necessary to find the number of minutes in the number of hundredths on the lobe of the cam to be milled.

The surface of the cam is divided into one hundred equal parts, and since there are 360 degrees in a circle, one-hundredth equals 3.6 degrees, or $3.6 \times 60 = 216$ minutes.

To find the number of minutes which is equal to 0.001 inch rise, divide the total number of minutes contained in the lobe by the total number of thousandths rise. When cutting the cam, the platen of the milling machine is moved till the cutter comes in contact with the edge or face of the cam; then the cutter is fed in 0.001 inch, and the circular attachment is turned the required number of minutes, which is equal to 0.001 inch rise. The milling operation is continued in this way until the lobe is completed. Milling the cam in this manner leaves

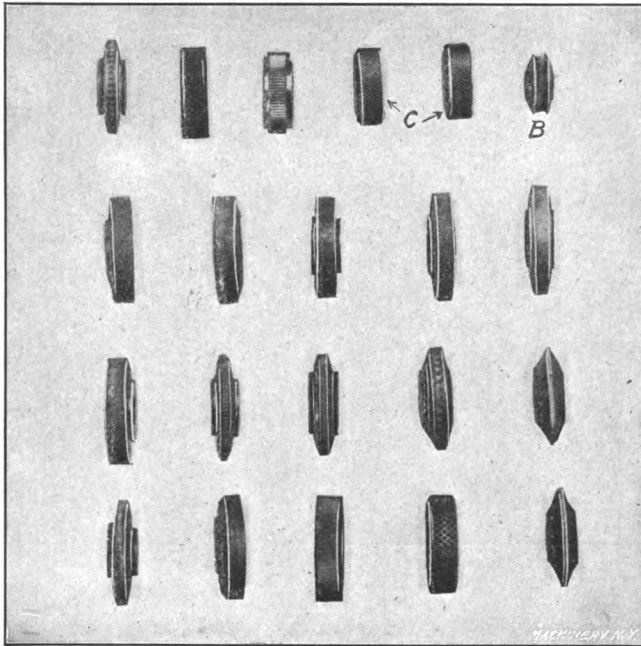

Fig. 18. A Collection of Knurls of Different Types

a series of little steps, or rises, which can be removed with a file, and in this way a true surface is obtained.

In the half tone, Fig. 17, are shown, in position, the tools used in making a knurled thumb nut. The cross-slide knurling tool illustrated in Fig. 1 is shown at *B* in position on the back cross-slide. In Fig 18 is shown a variety of knurls; at *B* is shown a concave knurl made by the method illustrated in Fig. 7, and at *C* is shown a pair of knurled pieces which will produce a diamond knurl as shown in Fig. 11, when they are used in the knurl-holder shown in Fig. 10.

CHAPTER II

TURRET KNURLING OPERATIONS

The previous chapter deals particularly with cross-slide knurling operations, while the present takes up knurling from the turret, and special knurling operations. An adjustable knurl-holder for turret knurling is shown in Fig. 19. This holder can be used for either spiral or straight knurling, as the knurl-holders *A* can be swiveled to any angle. The illustration shows the holders set with the zero mark opposite 30 degrees, in which position the knurls would produce a diamond knurl, as shown on the piece *A* in Fig. 21. The

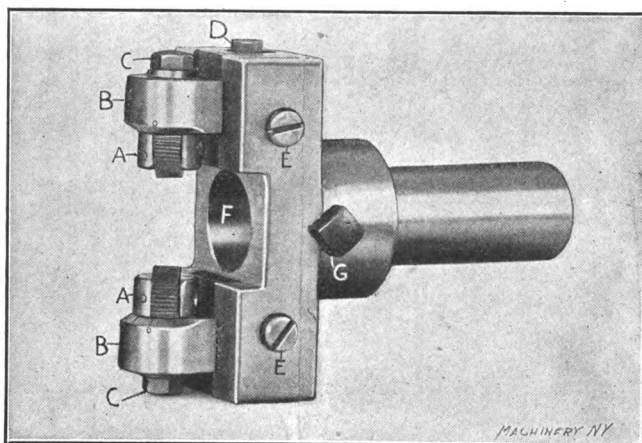

Fig. 19. Brown & Sharpe Adjustable Turret Knurl-holder

knurl-holders *A* are held in the lugs *B* by collar nuts *C* which are screwed onto the threaded shank of the holders. Lugs *B* are graduated at 5-degree intervals, so that the knurls can be easily set to the desired angle. These lugs project into the body of the holder and fit in beveled slots cut to receive them. The lugs are adjusted in and out by means of collar-head screws *D*, only one of which is shown in the illustration. These collar-head screws are locked by means of small brass shoes, operated on by the headless screws *E*.

This knurl-holder can also be provided with bushings which fit in the hole *F* for holding centering tools or other internal cutting tools, so that other operations can be performed at the same time as the knurling operation. The cutting tools are held in position in the bushing by means of the set-screw *G*. The chief advantage of this knurl-holder is that straight knurls can be used for spiral as well as for straight knurling. This is an important feature, as straight knurls

NAME Knurled Thumb Screw

MADE ON No 0 B & S AUTO. SCREW MACHINE

MATERIAL USED 3/8" Round Brass Rod

SPINDLE SPEEDS 1800 RPM FORWARD, 1800 RPM BACKWARD.

1 PIECE 14 SECONDS, 2571 PIECES GROSS PRODUCT IN 10 HRS

No 60 GEAR ON DRIVING SHAFT, No 28 GEAR ON WORM SHAFT.

No " " 1st STUD. No " " 2nd STUD.

CHUCKING.

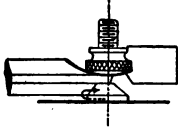

DESIGNER'S INITIALS D.T.H.
DATE, May 11, 1909

DWG. NO	TOOL NO	REV.	HUND.	START	FINISH	RISE	FEED	OPERATIONS PERFORMED.
		21.	5	0	5			Feed stock to stop and chuck
		25.2	6	5	11			Revolve turret
		50.4	12	11	23	0.240"	0.00476"	Rough turn (with hollow mill)
		37.8	9	6	15	0.062"	0.00184"	Form (dwell 0.01)
		25.2	6	23	29			Revolve turret
		29.4	7	29	36	0.250"	0.0099"	Finish turn (with Box-Tool; dwell 0.01)
		25.2	6	36	42			Revolve turret
		11.55	2 3/4	42	44 3/4	0.320"	0.164 x 36 P	Die on
		11.55	2 3/4	44 3/4	47 1/2	0.320"	0.164 x 36 P	Die off } Reverse Spindle
		18.9	4 1/2	47 1/2	52			Clearance
		29.4	7	52	59	0.075"	0.00255"	Knurl on rise
		4.2	1	59	60			Dwell with knurl while removing burr and pass over Center; rise 0.008
		16.8	4	60	64	0.020"	0.00158"	Remove burr (with form tool) dwell 0.01
		4.2	1	64	65	0.114"		Rise to cut-off
		21.	5	70	75	0.095"	0.00207"	Point Dwell 0.01 while cutting off
		88.2	21	65	86	0.156"	0.00175"	Start cut-off
		42.	10	86	96	0.040"	0.0009"	Finish cut-off } Revolve turret twice
		16.8	4	96	100			Clearance
		CAMS.						Lead, Front, Back

TOTAL REVS. TO PRODUCE ONE PIECE 420

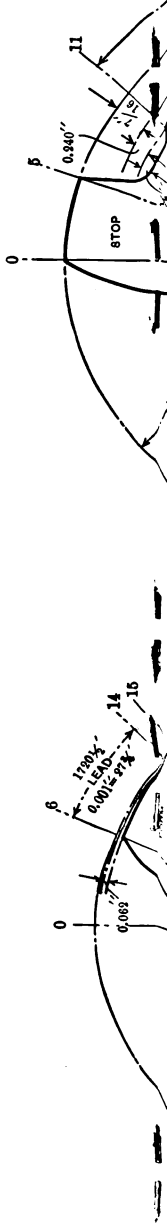

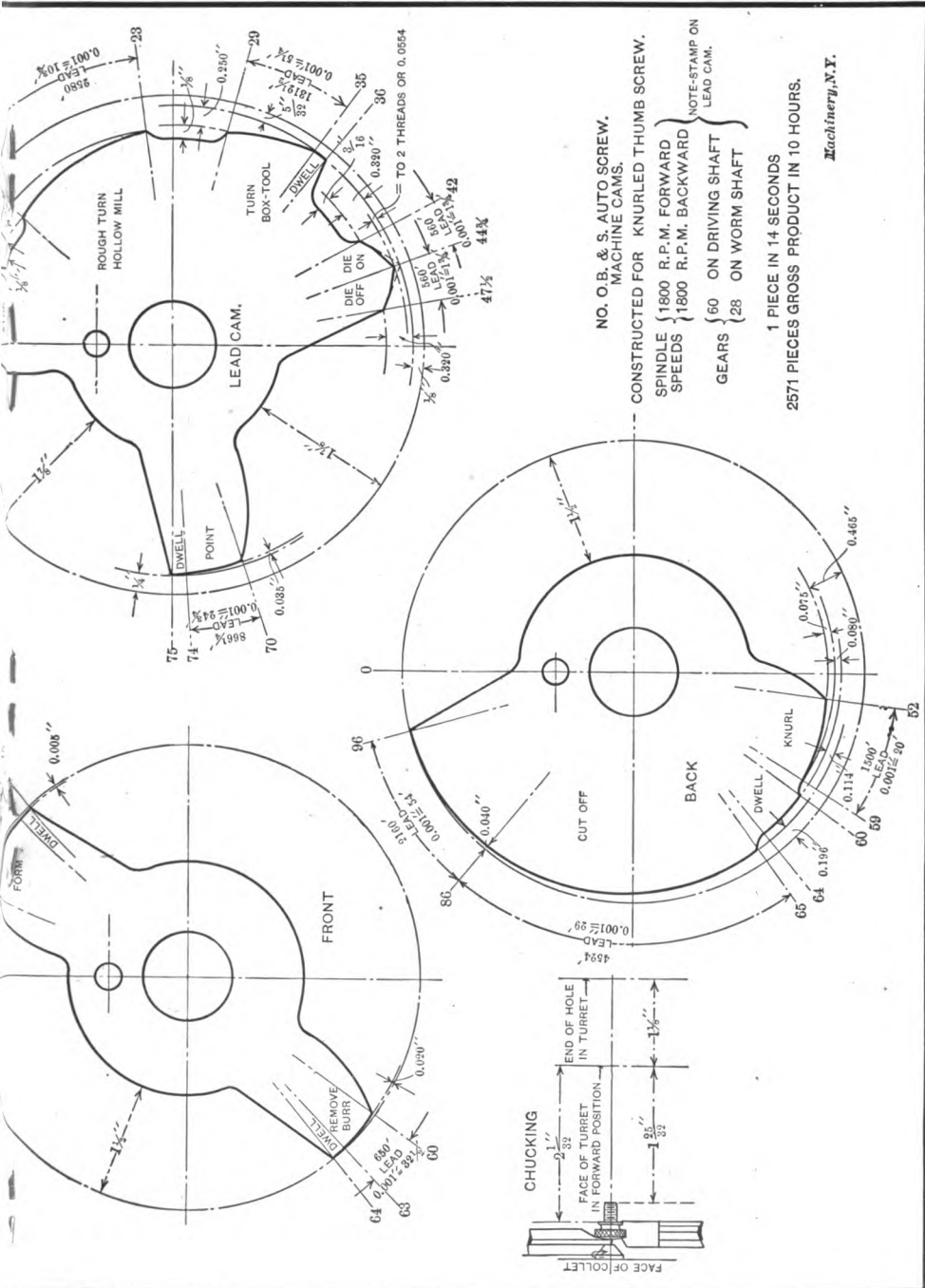

Fig. 20. Chart of Operations and Lay-out of Cams used for Making Thumb-screw shown in Fig. 13

are more easily and quickly cut than spiral knurls, and also produce better results.

Opening Knurl-holder

The range of the knurl-holder shown in Fig. 19 is somewhat limited, in that it is impossible to knurl work a distance away from the end, when the diameter to be knurled is smaller than or of the same size as the part preceding it. For this class of work it is necessary to bring the knurl-holder onto the work, and then force the knurls in to the depth required so that the work can be knurled in any desired position without passing over the whole surface. A knurl-holder which can be used for this class of work is shown in Fig. 22. This type is used especially for work similar to that shown at *B* and *C* in

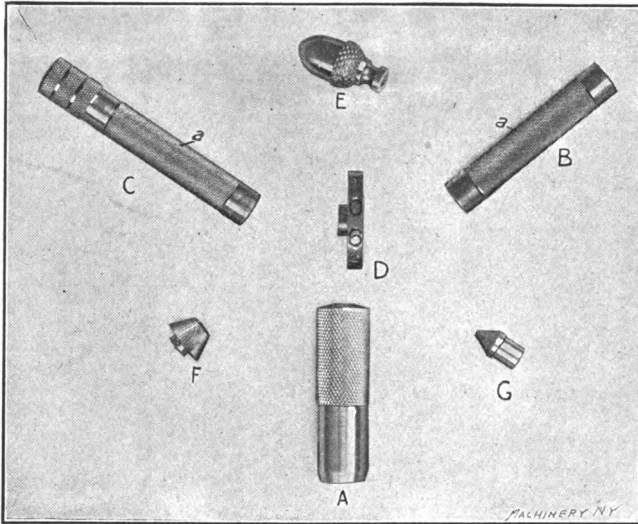

Fig. 21. Samples of Knurled Work

Fig. 21, where, as can be seen, the knurled portions *a* are practically in the center of the work.

The knurl-holder shown in Fig. 22 is made on the "swing" principle, and consists mainly of two swinging members *A*, in which the knurl-holders *B* are held by set-screws *C*. Rectangular holes are provided in the swinging members *A*, into which these knurl-holders *B* fit. As these two swinging members have to work together, it is necessary to connect them. This is accomplished, as shown in the illustration, by two connecting links *D*, attached to a stud *E* held in the main body of the holder *F* by the nut *G* which is screwed onto the shank of the stud.

In operation, the rising block, held on the cross-slide, presses against the point *a* of the screw *H*, and forces the right swinging member *A* in the direction of the arrow. This revolves the stud *E* in the direction of the arrow, which action, in turn, draws in the left swinging arm.

These members are held apart by coll spring *I* pressing against two spring plungers *J*, which, in turn, press against two pins *K* held in the swinging members. These pins *K* project into the main body of the holder, and are stopped by means of two headless screws *L*, which are tapped into the holder. The swinging members *A* are, as plainly shown, attached to the main body of the holder in the same manner as

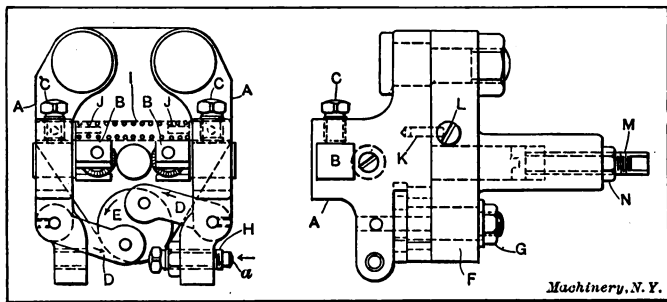

Fig. 22. Brown & Sharpe Opening Knurl-holder

an ordinary swing tool. The knurl-holders in this case, however, cannot be set to any desired angle, but are held rigidly, so to speak, in the swinging members. The forward ends of these holders are offset so that a straight knurl is held at an angle of 30 degrees with the axis of the holder for producing diamond knurling. However, the knurl-holder proper can be used for straight knurling or other knurling from

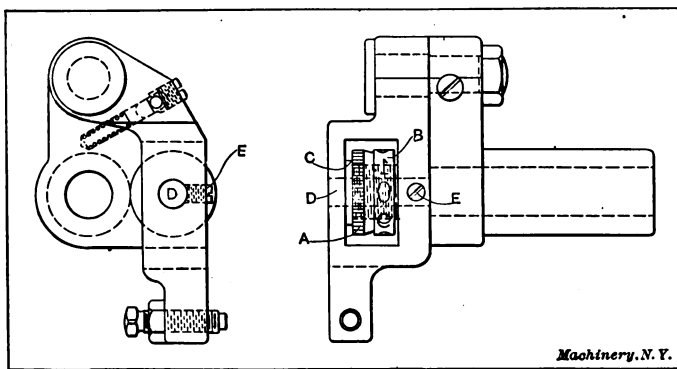

Fig. 23. Numbering Tool of the Swing Type

the turret, by supplying it with knurl-holders *B* of the desired shape to suit conditions.

This knurl-holder is provided with a stop *M*, similar in shape to an ordinary fillister-head screw, which is tapped into the shank of the holder. The screw is flattened on the end projecting from the holder, so that a wrench can be used for adjusting it, the nut *N*, of course, being used for locking when the stop is set in the desired position.

The advantage of this stop is that when all the holes in the turret are full and it is necessary to feed the stock out again, the holder will act as a stop when the stock is fed out into it. The rise on the lead cam is, of course, used to govern the position of the knurls on the work.

Numbering Tool

In Fig. 23 is shown a swinging knurl-holder which was used for rolling figures in a wheel for a cash register. The method of rolling

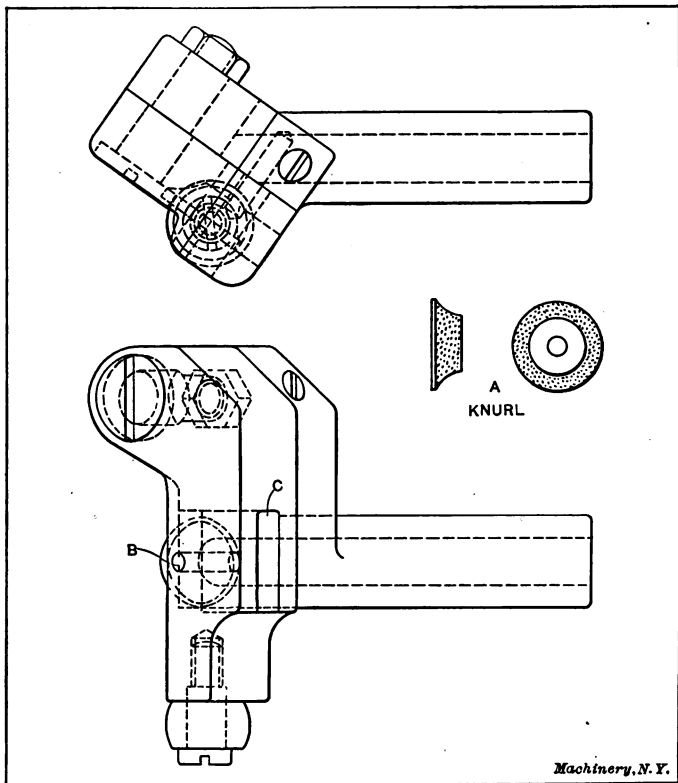

Fig. 24. Knurl-holder for Concave and Convex Knurling

the figures on the wheels is interesting. The knurl *A* and the numbering wheel *B* are made separately, and are screwed onto a sleeve *C* which, in turn, is held on a pin *D*. This pin is driven into the swinging member of the holder, and is held by a headless screw *E*.

The diameter of the knurl *A* is slightly larger than the diameter, over the figures, of the numbering wheel, so that the knurl comes in contact with the work first. The object of this is to provide a drive for the numbering wheel, so that it will not slip and "chew up" the figures which are being rolled in the work. The knurled portion is

removed, after the letters have been rolled, by a circular form tool operated from the cross-slide, which operation leaves the work in the condition shown at *D* in Fig. 21. This idea of using a knurl to drive the numbering tool is worth noting, as the same principle could be used in a number of cases for performing work of similar character..

Knurl-holder for Concave and Convex Knurling

At *E* in Fig. 21 is shown an acorn nut, a portion of which is knurled as indicated. This operation would be difficult to perform with a cross-slide knurl-holder, owing to the fact that the knurl could not be brought in straight—that is, having its axis parallel to the axis of the spindle—as the knurl would have a tendency to glide off. This, however, was accomplished by knurling from the turret with a knurl-holder operated by a rising block held on the cross-slide.

The knurl-holder for performing this operation, and the knurl used, are shown in Fig. 24. This knurl-holder is of the swing type, and is

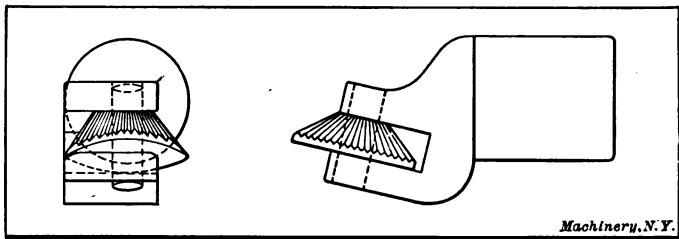

Fig. 25. Bevel Knurl-holder used in the Turret

offset as shown. The manner of holding the swinging member is that commonly used and needs no description. The angle to which the knurl-holder is offset is such that the knurl can be held with its axis parallel to the face of the work to be knurled. The face of the work in this case, however, is convex, so that the axis of the knurl is held parallel to an imaginary line, joining the smallest and largest diameters of the knurled portion. Forcing this knurl-holder in at an angle, makes it necessary to provide a roller on the swinging member, so that the pressure can be directed in a straight line and still deflect the swinging member to the required angle without cramping. The knurl *A* is held on a pin *B* driven into the swinging member of the holder, and a rectangular hole *C* is cut in the swinging member into which the knurl fits.

Holders for Bevel Knurling

At *F* in Fig. 21 is shown a piece which is beveled and knurled, and in Fig. 25 is shown the knurl and holder which were used to perform the knurling operation. The holder is of simple design and will not need further explanation. The knurl is held, as shown, at the desired angle with the work, on a pin driven into the knurl-holder. This simple knurl-holder performed the operation successfully.

At *G* in Fig. 21 is shown a piece somewhat similar to that at *F*, but it is smaller in diameter, and the included angle of the tapered por-

tion is less. This piece was not knurled from the turret, however, but was operated on by a cross-slide knurl-holder of the type shown in Fig. 26. The body *A* of this holder is cylindrical in shape, while the shank *B* is of rectangular section, and is held in the cross-slide holder used for holding straight forming tools. This holder can be furnished for the Brown & Sharpe automatic screw machine when so desired. The knurl *C* is made with a shank, which passes into the body of the holder *A* and is held in the holder by a pointed set-screw *D* fitting in an annular groove cut in the shank of the knurl. As the thrust

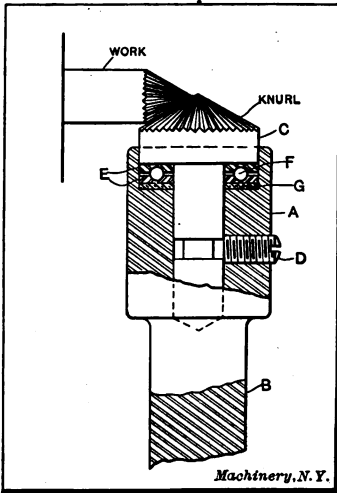

Fig. 26. Bevel Knurl-holder used on the Cross-slide

exerted on the knurl when in operation is considerable, it is necessary to provide this knurl-holder with roller bearings to reduce the friction. Two steel washers *E* act as retainers for the ball bearings *F*, and an additional bronze washer *G* is provided to separate the body of the holder from the tool-steel retainers. These retainers *E* are hardened, as is also the knurl *C*.

Turret Knurl-holder for End Knurling

It is sometimes necessary, when using special turret tools, especially those of the generating type, to knurl the end of the work so that the tool in the turret can be kept in step with the work. The knurl-holder, and knurl for performing this class of work are shown in Fig. 27.

The knurl *A* is held in the holder at an angle with the horizontal center line. The angle *a* at which the knurl is held should be from 15 to 30 degrees; about 20 degrees, however, is ordinarily used. The shank of the knurl *A* passes into the body of the holder and fits in a bronze sleeve *B*, the sleeve being driven into the holder. An oil groove is cut in this sleeve to supply oil to the shank of the knurl. A hardened steel washer *C* and a bronze washer *D* are also provided to reduce the friction. The knurl is held up against these washers *C* and *D* by a collar *E*, which is fastened to the shank of the knurl with a pin *F*.

This type of knurl-holder is also used for assembling operations. The piece to be assembled on the work in the chuck is put in place, and the knurl-holder is brought in, upsetting the end so that the part assembled cannot be taken off. A hole is usually drilled in the end of the knurl, as shown, to facilitate the cutting of the teeth.

Laying out Cams for Turret Knurling Operations

Knurling from the turret differs from knurling from the cross-slide, in that the turret knurl-holder cannot be taken off the work on the

quick drop of the cam. If this were done, the knurls would "chew up" the knurling which has been made on the forward travel of the knurls. The method of laying out the rise on the lead cam for knurling from the turret is shown in Fig. 28. This is the lay-out of a set of cams for making a Brown & Sharpe micrometer sleeve, shown at A in Fig. 21. The other machining operations on this sleeve, however, are not within the scope of this article, so we will turn our attention to the lobe which performs the knurling operation. This lobe is shown at A on the lead cam. It will be noted that the part of the lobe for the forward travel of the knurls covers a greater number of hundredths of the cam surface than does the part of the lobe used for backing the knurls off the work. As a rule, the part of the lobe used in backing the knurl off the work should contain about half the number of hundredths used for feeding the knurl onto the work, or, in other words,

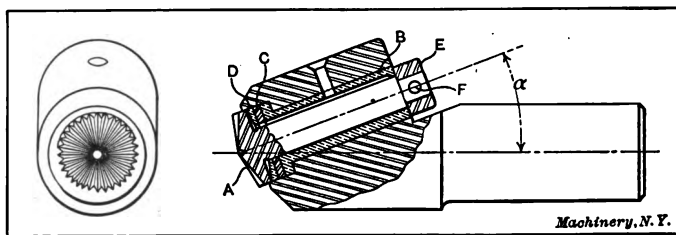

Fig. 27. Turret Knurl-holder for End Knurling

the feed used for backing-off should be about twice that used for feeding on.

Designing and Cutting Bevel and End Knurls

The making of bevel knurls differs from the making of bevel gears only in that the pitch circle of the knurl is not taken into consideration.

In Fig. 29 is shown the ordinary method of designing a bevel knurl. Angle α , of course, is made to conform to the face angle on the work. The face angle β on the knurl can be found by the following formula:

First find $\tan \eta$, which is equal to $\frac{d}{A}$ ($d =$ depth of tooth, and $A =$ length of face cone radius of knurl). The diameter of the knurl, D , is made to suit the requirements.

Then

$$\beta = \alpha + \eta$$

The included angles of the teeth for the knurls used in knurling different materials were given in the previous chapter, together with a table giving the depth of teeth for various included angles.

In Fig. 30 is shown a method of designing an end knurl. The bottom of the tooth in the knurl should be at right angles to the center line of the spindle when the knurl is held in the position shown, so that the face of the teeth on the knurl projects past the perpendicular,

thus forming the teeth in the work deeper at the outer circumference than at the center. In cutting the knurl, when the angle θ at which the knurl is held in the holder is known, the setting of the knurl in the milling machine is, of course a simple problem. The face angle of the

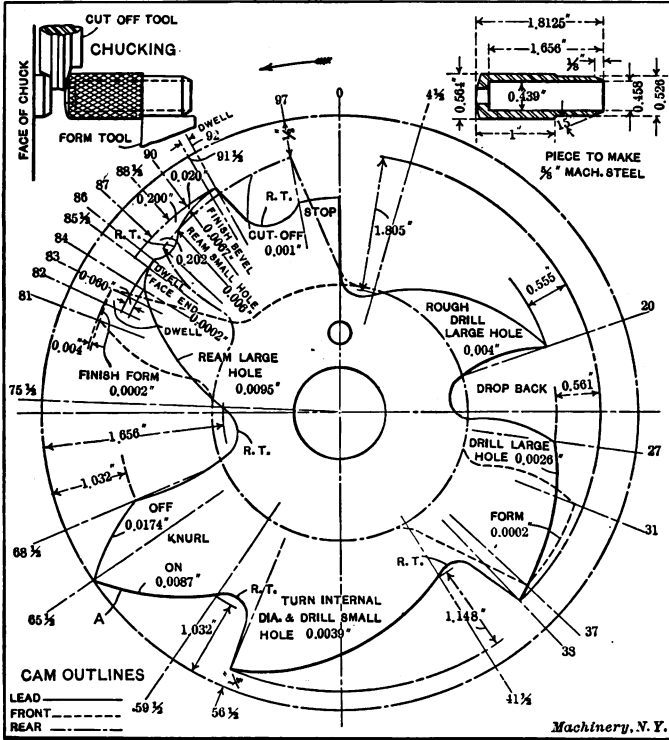

Fig. 28. Cams for Making Brown & Sharpe Micrometer Sleeve, showing Method of Laying out Lobe for Turret Knurling

knurl has to be found, however, before the knurl can be made. This angle can be found by the aid of the following formulas, in which

- θ = angle of inclination of axis of knurl,
- δ = angle of bottom of tooth with axis of knurl,
- γ = tooth angle,
- ϕ = face angle of knurl,
- R = radius of knurl, made to suit requirements,
- R_1 = distance from vertex to circumference at bottom of tooth,
- R_2 = distance from vertex to circumference at face of tooth,
- d_1 = depth of tooth.

$$\delta = 90 \text{ degrees} - \theta$$

$$R_1 = \frac{R}{\cos \theta}$$

$$R_2 = R_1 - (d_1 \times \tan \theta)$$

$$\tan \gamma = \frac{d_1}{R_2}$$

$$\phi = \theta - \gamma$$

For example, assume that it is required to design an end knurl with the following data:

- Angle $\theta = 20$ degrees ,
- Depth of tooth, $d_1 = 0.027$ inch,
- Radius of knurl, $R = 0.375$ inch.

Then

$$R_1 = \frac{0.375}{\cos 20 \text{ deg.}} = \frac{0.375}{0.9397} = 0.399 \text{ inch.}$$

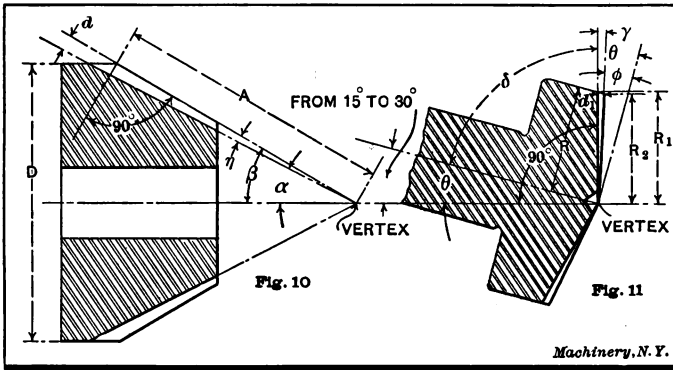

Fig. 29. Method of Finding the Cutting Angle of Bevel Knurls

Fig. 30. Method of Finding the Face Angle of End Knurls

$$R_2 = 0.399 - (0.027 \times \tan 20 \text{ deg.}) = 0.399 - 0.0098 = 0.389 \text{ in.}$$

$$\delta = 90 \text{ deg.} - 20 \text{ deg.} = 70 \text{ deg.}$$

$$\tan \gamma = \frac{0.027}{0.389} = 0.0694, \text{ the tangent of } 3 \text{ deg. } 58 \text{ min.}$$

$$\phi = 20 \text{ deg.} - 3 \text{ deg. } 58 \text{ min.} = 16 \text{ deg. } 2 \text{ min.}$$

For some classes of work it may be necessary to have the diameter of the knurl tapering, so that the circumference is at an angle of 90 degrees or less to the face of the knurl. This, however, decreases the strength of the teeth at the circumference, and promotes chipping of the teeth.

Rise on Lead and Cross-slide Cams for Turret Knurling

Knurling operations performed from the turret can be divided into five distinct groups as follows:

1. Spiral or diamond knurling, when the knurl-holder is operated on entirely by the lead cam.

2. Spiral or diamond knurling, when the knurl is operated on by both the lead and cross-slide cams.
3. Bevel knurling, when the knurl is operated entirely from the turret.
4. Bevel knurling, when the knurl is operated on by both the lead and cross-slide cams.
5. End knurling, when the knurl is operated on entirely from the turret.

The rise on the cam for knurling from the turret, subject to the conditions above stated, can be found by referring to Fig. 31. At A is shown the diagram for spiral or straight knurling when the knurl

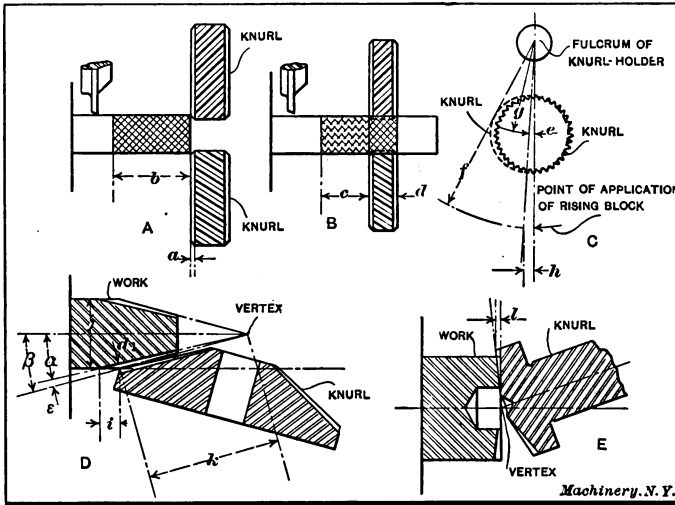

Fig. 31. Diagrams for Finding Rise on Lead and Cross-slide Cams for Turret Knurling

is operated on entirely from the turret. The rise on the lead cam for this operation would be $b + a$. The value a takes into consideration the bevel on the knurl, which is necessary to prevent the corners from chipping.

For spiral or straight knurling when the knurl is operated on by both the turret and cross-slide cams, the diagrams shown at B and C are used. Here the lead cam brings the knurls onto the work into the position shown, by the quick-rise of the cam. A dwell is then made on the lead cam, and the cross-slide cam forces the knurls in to the proper depth. The lead cam then advances, while a dwell is made on the cross-slide cam. The rise on the lead cam is equal to c , or the length of the knurled portion, minus the thickness d of the knurl. The rise h on the cross-slide cam is found by the following formula:

$$h = \frac{e \times f}{g}$$

The value e is equal to the depth of the tooth. This value is slightly greater than the rise on the cam required for knurling, as the material is displaced. However, the depth of the tooth, e , is near enough for all practical purposes.

The method of obtaining the rise on the cam for bevel knurling when the knurl is operated on entirely by the lead cam, is shown at D , where i equals the rise required on the cam. The rise i is obtained by means of the following formulas, where

k = face cone radius of work,

j = diameter of work,

TABLE IV. FEEDS FOR TURRET KNURLING

Pitch of Knurl	Brass Rod, Feed per Revolution	Gun Screw Iron, Feed per Revolution	Machine Steel, Feed per Revolution	Tool Steel, Feed per Revolution
16	0.0100	0.0080	0.0060	0.0040
18	0.0105	0.0084	0.0063	0.0042
20	0.0110	0.0088	0.0065	0.0044
22	0.0115	0.0092	0.0068	0.0046
24	0.0118	0.0096	0.0070	0.0048
26	0.0123	0.0100	0.0072	0.0050
28	0.0128	0.0103	0.0074	0.0051
30	0.0135	0.0106	0.0076	0.0052
32	0.0140	0.0110	0.0078	0.0053
34	0.0145	0.0115	0.0080	0.0054
36	0.0150	0.0120	0.0082	0.0056
38	0.0153	0.0125	0.0084	0.0057
40	0.0158	0.0128	0.0086	0.0058
42	0.0164	0.0132	0.0088	0.0059
44	0.0168	0.0136	0.0090	0.0061
46	0.0173	0.0140	0.0092	0.0062
48	0.0178	0.0143	0.0094	0.0063
50	0.0182	0.0145	0.0098	0.0064
52	0.0185	0.0148	0.0103	0.0065
54	0.0189	0.0150	0.0108	0.0066
56	0.0193	0.0153	0.0111	0.0067
58	0.0195	0.0156	0.0115	0.0068
60	0.0198	0.0158	0.0118	0.0069
62	0.0200	0.0160	0.0120	0.0070

i = rise required on cam,

α = angle of bottom of tooth with axis of work,

β = angle of face with axis of work,

e = tooth angle,

d_1 = depth of tooth.

$$k = \frac{j}{2 \sin \beta}; \sin \epsilon = \frac{d_1}{k}; \alpha = \beta - \epsilon$$

Then

$$i = \frac{d_1}{\sin \alpha} + 0.010 \text{ to } 0.015 \text{ inch.}$$

The method used for obtaining the rise on the cross-slide cam for bevel knurling when the knurl is operated on by both the lead and

cross-slide cams, is the same as that shown at *C* in Fig. 31. The holder in which the knurl is held is offset, so that the face of the knurl is held parallel with the face of the work when being fed in. The depth of the tooth, therefore, is used for obtaining the rise on the cross-slide cam, by the aid of the diagram shown at *C*. No rise is required on the lead cam, as the knurl is brought to the correct position on the work by the quick-rise of the cam, and then allowed to dwell until the knurling is completed.

The method of obtaining the rise on the lead cam for end knurling is shown at *E*, where it can be seen that the rise l equals the depth of the tooth. To dimension l should be added from 0.010 to 0.015 inch for the approach.

Speeds and Feeds for Knurling

Knurls, as a rule, can be operated at about the same speed as circular forming tools, if the proper feed is given and the knurl is provided with a copious supply of good lard oil. However, it may be advisable in some cases, especially when knurling tool steel or drill rod, to decrease the speed somewhat.

Definite information cannot be given for feeds for turret knurling, as it is impossible to take into consideration all the various conditions under which a knurl will be operated. When two knurls are employed for diamond or spiral knurling, the knurls can be operated at a higher rate of feed for producing a spiral than they can for producing a diamond knurl. The reason for this is that in the first case the two knurls would be working in the same groove, whereas in the latter case the two knurls are working independently of each other, so that each has to do its own share of the work. Another condition encountered is end knurling where the knurl only has to be fed in to the depth of the tooth. Here the feed varies, of course, from that used for spiral or diamond knurling; so it is obvious that no definite rule can be laid down which will cover all conditions. The diameter of the work is also a determining factor, making the problem still more difficult. Feeds for turret knurling are given in Table IV for knurling different materials. The feeds here given are applicable particularly to spiral and diamond knurling, but can also be used, with judgment, for bevel or end knurling. The diameter of the work is not taken into consideration, and allowance should be made for this when using the feeds given. The feeds to be used for backing the knurls off the work should be as follows: For brass, screw stock and machine steel, twice the feeds given in the table; and for tool steel, three times the feeds given in the table.

CHAPTER III

SPECIAL KNURLING OPERATIONS

The knurling operations dealt with in the previous chapters are what might be called "standard," and are met with frequently in automatic screw machine practice. The following examples are of a more special nature, and illustrate unusual applications of knurls. The data which follows should be of suggestive value to the designer of screw machine tools, inasmuch as it presents commendable methods of applying knurls to the work under varying conditions.

Bevel Knurling Tools operated from the Turret

The simple bevel knurling tool shown in Fig. 33 is provided with a tapered shank and is held in a standard floating holder in the tur-

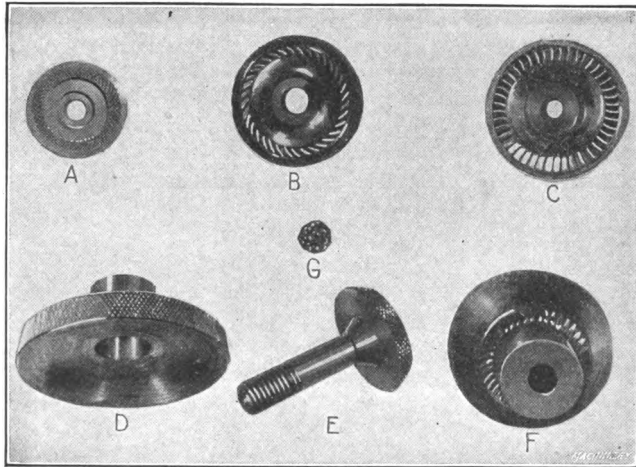

Fig. 32. Examples of Work Requiring Special Knurls and Knurl-holder Applications

ret. The piece to be knurled, A, is a small German silver button which has a convex face, but as the curvature is slight, a straightface diamond knurl can be used. In applying the knurl to the work, the center line *BC* of the knurl should be at right angles to that portion of the work it is required to knurl. This particular holder was used in a No. 00 Brown & Sharpe automatic screw machine, which was operated at a spindle speed of 1492 R. P. M., and with a feed to the knurl of 0.0023 inch per revolution of the work.

Another example of end-knurling from the turret is shown in Fig. 34. The piece to be knurled is shown at A, and also at F in Fig. 32. The knurl is presented from the turret under the body of the work,

and produces a single spiral knurl, the teeth of which are at an angle of 25 degrees with the axis of the work. The holder is held in a No. 2 Brown & Sharpe automatic screw machine, and the work is rotated at

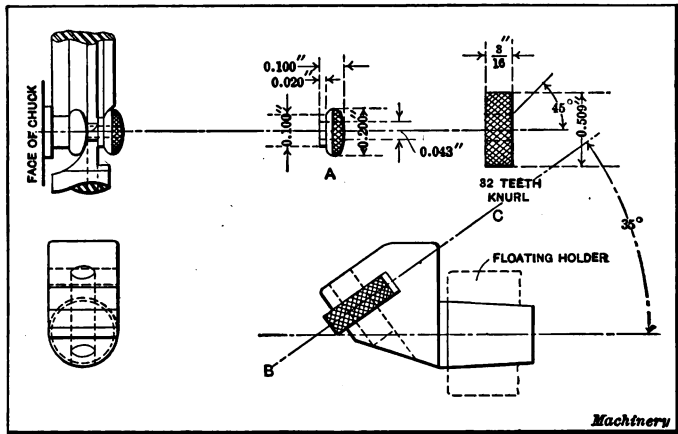

Fig. 33. End-knurling Tool held in Floating Holder

1200 R. P. M., with a feed to the knurl of 0.0024 inch per revolution.

The knurl holder consists of a shank B which fits the hole in the turret, and a holder C held to the body B by a screw, and located by a tongue and groove. The hole for screw D in holder C is larger than

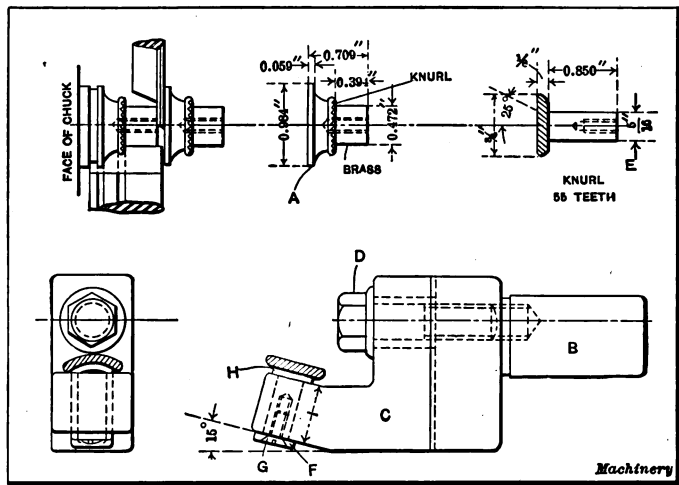

Fig. 34. End-knurling Tool held in Turret and Operated at an Angle

the body diameter of the screw, to provide for adjustment. The knurl which is shown detailed at E is provided with a shank which is a running fit in the hole in holder C. It is retained by a washer F and screw G and rotates on a hardened washer H. The distance I on the

knurl shank is slightly greater than the width of the holder, so as to allow the knurl and washer *G* to rotate freely.

The knurl *B* and the knurl holder *D* shown in Fig. 35 are used to produce a ratchet form of radial teeth in the shoulder of the piece

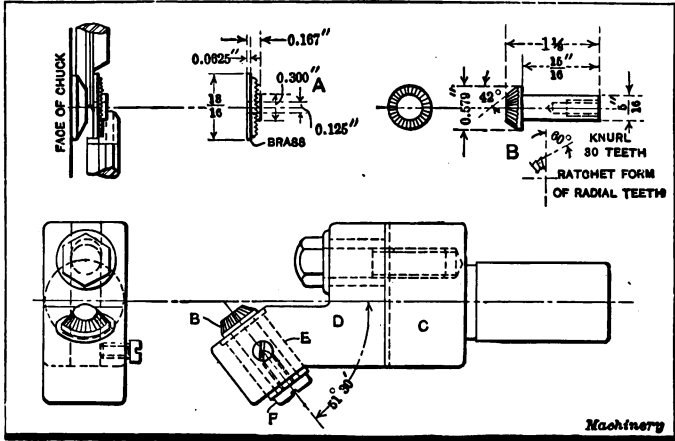

Fig. 35. Knurl and Knurling Tool-holder for producing Ratchet Form of Radial Teeth

shown at *A*, and also at *C* in Fig. 32. The teeth in the knurl are cut at an angle of 60 degrees and are radial. The work is rotated at 1216 R. P. M., and a feed of 0.0008 inch is given to the knurl per revolution of the work.

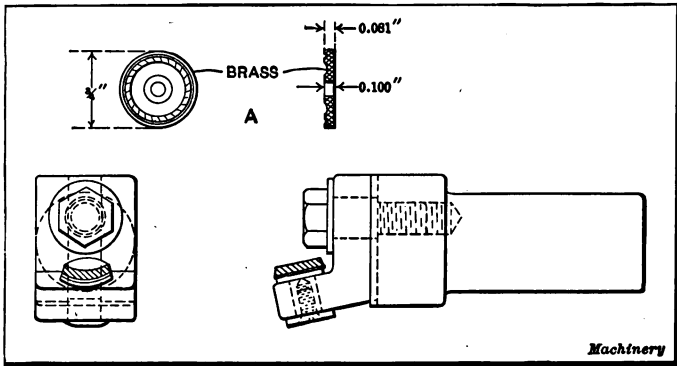

Fig. 36. Knurl and Holder for producing "Tangential" Form of Knurl

This holder is held in the turret of a No. 2 Brown & Sharpe automatic screw machine, and consists of a body and shank *C* to which the holder *D* is held by a screw. The knurl *B* rotates in a phosphor-bronze bushing which is prevented from turning by a screw. The knurl is retained in the bushing by a large-headed screw *F* provided with a shoulder. There is sufficient end play to allow the knurl to

rotate freely. It should be noted that in presenting the knurl to the work, the bottom of the teeth in the knurl should be at right angles to the center line of the holder or of the work.

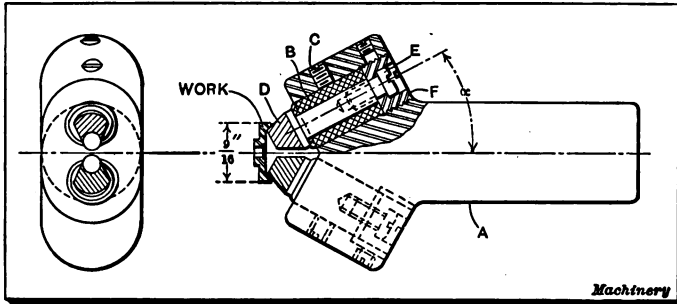

Fig. 37. Special Knurls and Holder for Internal Bevel Knurling

A knurl-holder bearing a marked similarity to that shown in Fig. 35 is illustrated in Fig. 36. In this case, however, the knurl is used for producing "tangential" teeth, as shown on the piece B, Fig. 32, and consequently it is provided with spiral teeth. It is not inclined at so small an angle with the center line of the holder, and approaches,

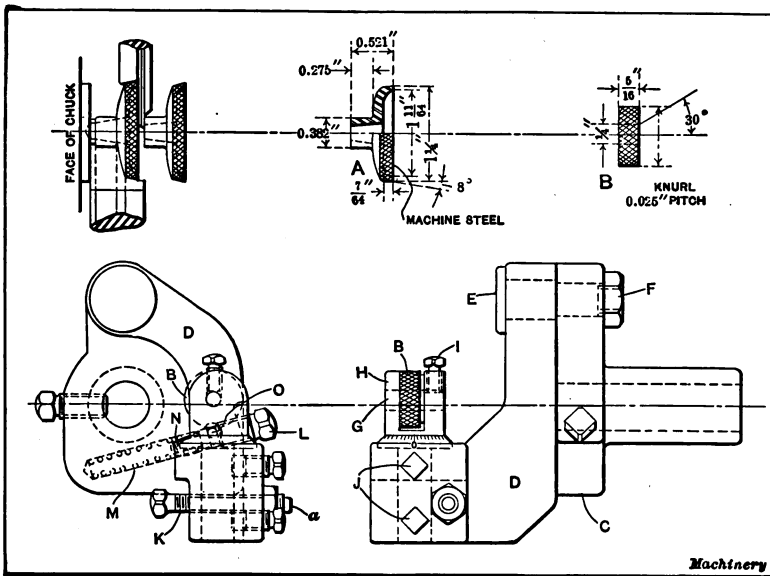

Fig. 38. Swing Type of Turret Knurl-holder for Knurling at Various Angles when in operation on the work, as closely as conditions will permit, the action of a helical gear in mesh.

Internal Turret Knurl-holder

A special application of two bevel spiral knurls to the work is shown in Fig. 37. Here the portion of the work to be knurled is beveled at

an included angle of approximately 90 degrees, and as shown at A in Fig. 32, a diamond-shaped knurl is to be produced. This operation can be more easily accomplished in this case with two spiral knurls than would be possible with one diamond knurl. Under these conditions it is advisable to have the angle α slightly less than half the angle on the work, so that it will be possible to use a bevel knurl, as a straight knurl would not work freely when operated from either the turret or cross-slide.

The holder A, Fig. 37, which is held in the turret, is made from a machine steel forging and is supplied with two lugs, bored to receive the phosphor-bronze bushings B, these being retained in the holder by

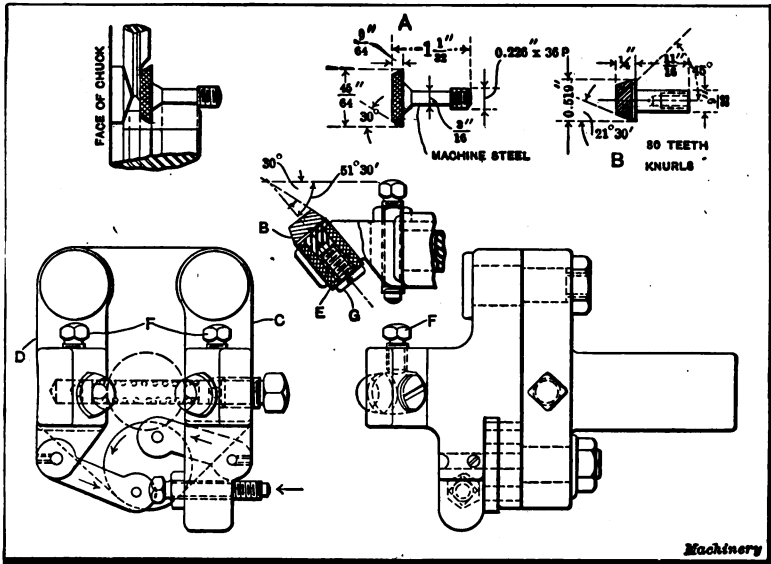

Fig. 39. Opening Type of Turret Knurl-holder for Bevel Knurling

screws C. The knurls D are provided with shanks and are retained in bushings B by screws E, which rotate with the knurls. The end thrust of the knurls in this holder is considerable, so that it is necessary to back up the bushings B with screws F.

Special Swing Knurl-holder

A special knurl holder which is held in the turret and operated from the cross-slide by a rising block under the front tool-post, is shown in Fig. 38. The work is shown at A, and also at D-in Fig. 32. It will be noticed that the work is considerably greater in diameter than suitable for the ordinary capacity of the No. 2 Brown & Sharpe automatic screw machine, thus requiring the use of a special outside feeding attachment, the ordinary feed tube being removed. The work is revolved at 240 R. P. M., and the knurl holder advanced at the rate of 0.00077 inch per revolution of the work. This is the speed at which

the swinging arm *D* is moved, so that the actual feed to the knurl will be somewhat less than this amount.

The main body of holder *C* is provided with a shank held in the turret, and the swinging member *D* is held to its front face by a bolt *E* and nut *F*. The knurl *B* is held on pin *G* retained in the swivel holder *H* by screw *I*. The holder *H* is provided with angular graduations reading to degrees, so that the knurl can be set to the desired angle with the work. In the illustration the knurl is set straight, but in actual operation it is set around at an angle of 8 degrees. The shank of holder *H* is retained in the swinging member *D* by two set-screws *J*, which operate on bronze shoes to prevent marring the shank.

In operation, the rising block on the cross-slide comes in contact with the point *a* of the adjusting screw *K*, forcing the knurl into the work. The swinging member is returned to adjustable stop-screw *L* by a spring *M*, plunger *N* and pin *O*, the latter being driven into the swinging member and operating in an elongated hole in the holder *C*.

Special Opening Knurl-holder

An opening type of knurl-holder of a design almost identical with that shown in Fig. 22, is shown in Fig. 39. Two bevel knurls *B* are held in the swinging arms *C* and *D* in the manner shown in the sectional view. These arms are provided with offset lugs bored to receive the phosphor-bronze bushings *E*, which are prevented from turning by set-screws *F*. The knurls *B* are provided with shanks and are retained in the bronze bushings by screws *G*. The type of holder shown gives better results on the piece shown at *A*, and also at *E* in Fig. 32, than would a holder held on the cross-slide which would force the knurl straight into the work. The reason for this is that in operating a bevel knurl from the cross-slide on a tapered piece of work, the knurl has a tendency to glide off and produce an imperfect form of knurl. The opening type of holder obviates this difficulty to a considerable extent, as the power can be applied, so to speak, at right angles to the surface knurled. The knurls are brought into position by the turret and then fed into the work by the rising block on the cross-slide.

OUTLINE OF A COURSE IN SHOP AND DRAFTING-ROOM MATHEMATICS, MECHANICS, MACHINE DESIGN AND SHOP PRACTICE

Any intelligent man engaged in mechanical work can acquire a well-rounded mechanical education by using as a guide in his studies the outline of the course in mechanical subjects given below. The course is laid out so as to make it possible for a man of little or no education to go ahead, beginning wherever he finds that his needs begin. The course is made up of units so that it may be followed either from beginning to end; or the reader may choose any specific subject which may be of especial importance to him.

Preliminary Course in Arithmetic
JIG SHEETS 1A to 5A:—Whole Numbers: Addition, Subtraction, Multiplication, Division, and Factoring.

JIG SHEETS 6A to 15A:—Common Fractions and Decimal Fractions.

Shop Calculations

Reference Series No. 18. SHOP ARITHMETIC FOR THE MACHINIST.

Reference Series No. 52. ADVANCED SHOP ARITHMETIC FOR THE MACHINIST.

Reference Series No. 53. USE OF LOGARITHMIC TABLES.

Reference Series Nos. 54 and 55. SOLUTION OF TRIANGLES.

Data Sheet Series No. 16. MATHEMATICAL TABLES. A book for general reference.

Drafting-room Practice

Reference Series No. 2. DRAFTING-ROOM PRACTICE.

Reference Series No. 8. WORKING DRAWINGS AND DRAFTING-ROOM KINKS.

Reference Series No. 33. SYSTEMS AND PRACTICE OF THE DRAFTING-ROOM.

General Shop Practice

Reference Series No. 10. EXAMPLES OF MACHINE SHOP PRACTICE.

Reference Series No. 7. LATHE AND PLANER TOOLS.

Reference Series No. 25. DEEP HOLE DRILLING.

Reference Series No. 38. GRINDING AND GRINDING MACHINES.

Reference Series No. 48. FILES AND FILING.

Reference Series No. 32. SCREW THREAD CUTTING.

Data Sheet Series No. 1. SCREW THREADS. Tables relating to all the standard systems.

Data Sheet Series No. 2. SCREWS, BOLTS AND NUTS. Tables of standards.

Data Sheet Series Nos. 10 and 11. MACHINE TOOL OPERATION. Tables relating to the operation of lathes, screw machines, milling machines, etc.

Reference Series Nos. 50 and 51.

PRINCIPLES AND PRACTICE OF ASSEMBLING MACHINE TOOLS.

Reference Series No. 57. METAL SPINNING.

Jigs and Fixtures

Reference Series Nos. 41, 42 and 43. JIGS AND FIXTURES.

Reference Series No. 3. DRILL JIGS.

Reference Series No. 4. MILLING FIXTURES.

Punch and Die Work

Reference Series No. 6. PUNCH AND DIE WORK.

Reference Series No. 13. BLANKING DIES.

Reference Series No. 26. MODERN PUNCH AND DIE CONSTRUCTION.

Tool Making

Reference Series No. 64. GAGE MAKING AND LAPPING.

Reference Series No. 21. MEASURING TOOLS.

Reference Series No. 31. SCREW THREAD TOOLS AND GAGES.

Data Sheet Series No. 3. TAPS AND THREADING DIES.

Data Sheet Series No. 4. REAMERS, SOCKETS, DRILLS, AND MILLING CUTTERS.

Hardening and Tempering

Reference Series No. 46. HARDENING AND TEMPERING.

Reference Series No. 63. HEAT TREATMENT OF STEEL.

Blacksmith Shop Practice and Drop Forging

Reference Series No. 44. MACHINE BLACKSMITHING.

Reference Series No. 61. BLACKSMITH SHOP PRACTICE.

Reference Series No. 45. DROP FORGING.

Automobile Construction

Reference Series No. 59. MACHINES, TOOLS AND METHODS OF AUTOMOBILE MANUFACTURE.

Reference Series No. 60. CONSTRUCTION AND MANUFACTURE OF AUTOMOBILES.

Theoretical Mechanics

Reference Series No. 5. FIRST PRINCIPLES OF THEORETICAL MECHANICS.

Reference Series No. 19. USE OF FORMULAS IN MECHANICS.

Gearing

Reference Series No. 15. SPUR GEARING.

Reference Series No. 37. BEVEL GEARING.

Reference Series No. 1. WORM GEARING.

Reference Series No. 20. SPIRAL GEARING.

Data Sheet Series No. 5. SPUR GEARING. General reference book containing tables and formulas.

Data Sheet Series No. 6. BEVEL, SPIRAL AND WORM GEARING. General reference book containing tables and formulas.

General Machine Design

Reference Series No. 9. DESIGNING AND CUTTING CAMS.

Reference Series No. 11. BEARINGS.

Reference Series No. 56. BALL BEARINGS.

Reference Series No. 58. HELICAL AND ELLIPTIC SPRINGS.

Reference Series No. 17. STRENGTH OF CYLINDERS.

Reference Series No. 22. CALCULATIONS OF ELEMENTS OF MACHINE DESIGN.

Reference Series No. 24. EXAMPLES OF CALCULATING DESIGNS.

Reference Series No. 40. FLY-WHEELS.

Data Sheet Series No. 7. SHAFTING, KEYS AND KEYWAYS.

Data Sheet Series No. 8. BEARINGS, COUPLINGS, CLUTCHES, CRANE CHAIN AND HOOKS.

Data Sheet Series No. 9. SPRINGS, SLIDES AND MACHINE DETAILS.

Data Sheet Series No. 19. BELT, ROPE AND CHAIN DRIVES.

Machine Tool Design

Reference Series No. 14. DETAILS OF MACHINE TOOL DESIGN.

Reference Series No. 16. MACHINE TOOL DRIVES.

Crane Design

Reference Series No. 23. THEORY OF CRANE DESIGN.

Reference Series No. 47. DESIGN OF ELECTRIC OVERHEAD CRANES.

Reference Series No. 49. GIRDERS FOR ELECTRIC OVERHEAD CRANES.

Steam and Gas Engine Design

Reference Series Nos. 67 to 72, inclusive. STEAM BOILERS, ENGINES, TURBINES AND ACCESSORIES.

Data Sheet Series No. 15. HEAT, STEAM, STEAM AND GAS ENGINES.

Data Sheet Series No. 13. BOILERS AND CHIMNEYS.

Reference Series No. 65. FORMULAS AND CONSTANTS FOR GAS ENGINE DESIGN.

Special Course in Locomotive Design Reference Series No. 27. BOILERS, CYLINDERS, THROTTLE VALVE, PISTON AND PISTON ROD.

Reference Series No. 28. THEORY AND DESIGN OF STEPHENSON AND WAL-SCHAERTS VALVE MOTION.

Reference Series No. 29. SMOKE-BOX, FRAMES AND DRIVING MACHINERY. Reference Series No. 30. SPRINGS, TRUCKS, CAB AND TENDER.

Data Sheet Series No. 14. LOCOMOTIVE AND RAILWAY DATA.

Dynamos and Motors

Reference Series No. 34. CARE AND REPAIR OF DYNAMOS AND MOTORS.

Data Sheet Series No. 20. WIRING DIAGRAMS, HEATING AND VENTILATION, AND MISCELLANEOUS TABLES.

Reference Series Nos. 73 to 78, inclusive. PRINCIPLES AND APPLICATIONS OF ELECTRICITY.

Heating and Ventilation

Reference Series No. 39. FANS, VENTILATION AND HEATING.

Reference Series No. 66. HEATING AND VENTILATING SHOPS AND OFFICES.

Data Sheet Series No. 20. WIRING DIAGRAMS, HEATING AND VENTILATION, AND MISCELLANEOUS TABLES.

Iron and Steel

Reference Series No. 36. IRON AND STEEL.

Reference Series No. 62. TESTING THE HARDNESS AND DURABILITY OF METALS.

General Reference Books

Reference Series No. 35. TABLES AND FORMULAS FOR SHOP AND DRAFTING-ROOM.

Data Sheet Series No. 12. PIPE AND PIPE FITTINGS.

Data Sheet Series No. 17. MECHANICS AND STRENGTH OF MATERIALS.

Data Sheet Series No. 18. BEAM FORMULAS AND STRUCTURAL DESIGN.

Data Sheet Series No. 20. WIRING DIAGRAMS, HEATING AND VENTILATION AND MISCELLANEOUS TABLES.

