

LIBRARY
OF THE STATE
COLLEGE

MACHINERY'S REFERENCE SERIES

EACH PAMPHLET IS ONE UNIT IN A COMPLETE
LIBRARY OF MACHINE DESIGN AND SHOP
PRACTICE REVISED AND REPUB-
LISHED FROM MACHINERY

No. 10—EXAMPLES OF MACHINE SHOP PRACTICE

By H. P. FAIRFIELD

CONTENTS

Cutting Bevel Gears with a Rotary Cutter	- - -	3
Making a Worm-Gear	- - - - -	17
Spindle Construction	- - - - -	33

WASU
STATE AG INT
303.100

G21.834
Y16

copy

CHAPTER I.

CUTTING BEVEL GEARS WITH A ROTARY CUTTER.

Pictures are a great help in understanding a machine shop operation. It is often possible, with a few half-tones, to convey ideas that would require many pages of written matter to express them. In the present pamphlet advantage has been taken of this facility of the photograph to express ideas, so that a long story has been told in comparatively few words.

While the process of forming the teeth of a bevel gear, by milling them with a rotary cutter, is not easy to describe without telling how to make a drawing of the blank, it seems best to leave the designing and drawing for a treatise more particularly dealing with this subject alone. The average apprentice approaches the problems of the ma-

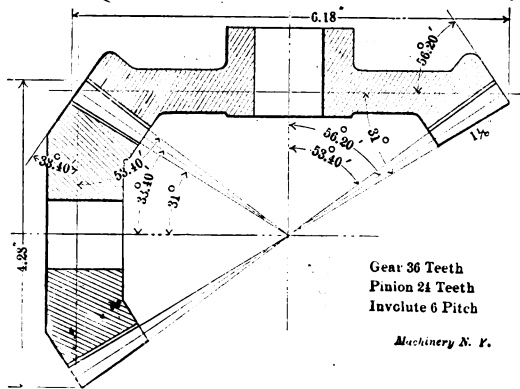

Fig. 1. Essential Dimensions of the Gear to be Cut.

chine shop with hardly enough knowledge of the art of making drawings to enable him to read them, to say nothing of making them.

The Drawing.

Fig. 1 represents the drawing of a bevel gear and its pinion, as it is given to the workman. It is to be noted that draftsmen are not all bound by the same conventions, but this drawing is as it would be made by at least one large firm who cuts many bevel gears. All dimensions other than those necessary to our description have been omitted to avoid confusion. The description will, therefore, be confined to those operations bearing upon the subject at hand, and will show what, in the author's estimation, should be the best order of operation to insure accuracy, convenience, and speed. In machining

34795

EXAMPLES OF SHOP PRACTICE

the blank to the required angles and dimensions, use is made of an engine lathe fitted with a compound tool-slide, and the tooth-cutting operations are made in a milling machine fitted with a universal index head, with graduated dials on its feed screws.

In the drawing Fig. 1 are stated the angles needed to turn up

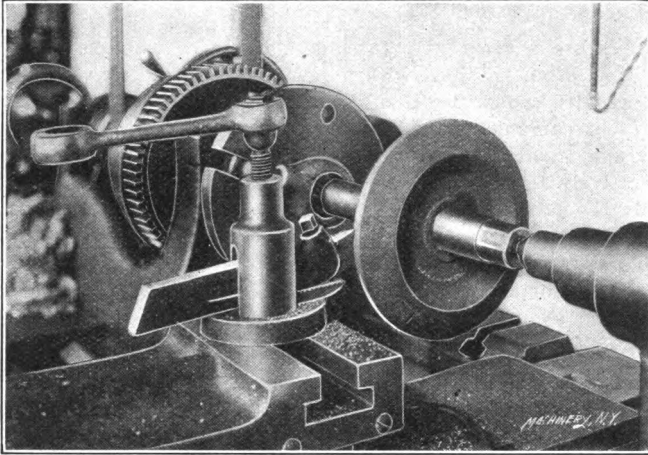

Fig. 2. Sizing the Outside Diameter of the Blank.

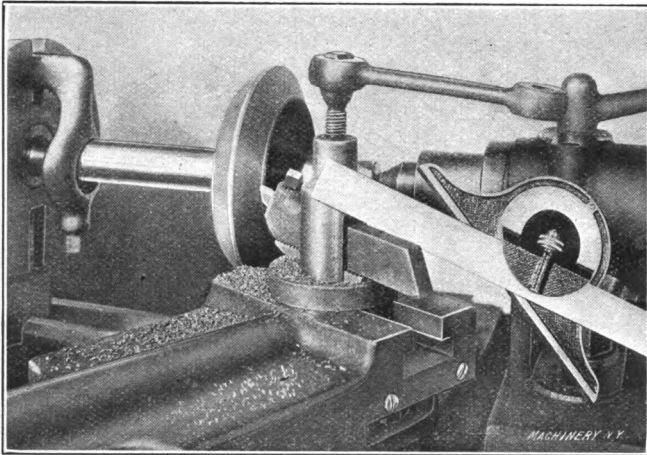

Fig. 3. Turning the Face.

the blank, and those needed when cutting the teeth. Those angles which are to be worked out in the lathe, using the compound slide, are given from a line normal to, or at right angles to, the center line of the blank. When given in this way, they conform to the graduations on the compound slide of the lathe, and all calculations by the workman in the shop are avoided. The cutting angle is figured from

the center line to conform with the graduations upon the milling machine. The diameter of the gear, as drawn, is 6.18 inches, and operation No. 1 is to size the blank to this diameter. While some draftsmen in bevel gear work give the outside diameter to thousandths of an inch, the nearest hundredth is sufficiently accurate.

Turning the Blank.

Fig. 2 shows operation No. 1, sizing the outside diameter, which leaves a flat surface easy to caliper.

Operation No. 2, shown in Fig. 3, is the turning of the face angle. As given on the drawing, this angle is 31 degrees, and the compound slide, as shown in the cut, is set to conform to this. In setting the slide, the nearest quarter degree is all that is needed. A sufficient

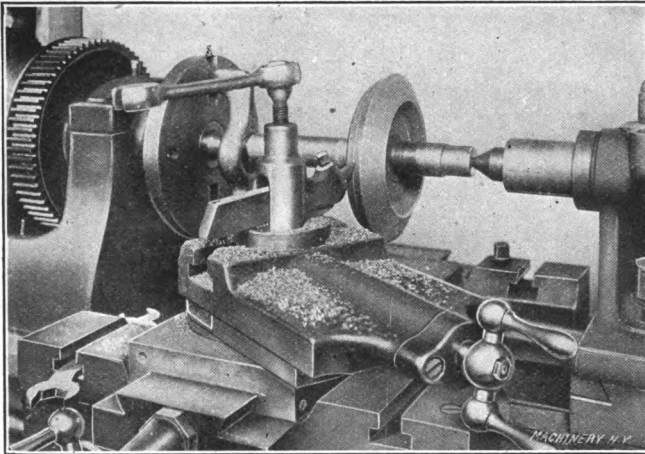

Fig. 4. Turning the Outer Edge.

amount of stock is removed by this operation to leave a well-finished surface for the tops of the teeth.

Fig. 4 shows operation No. 3, which is the forming of the back angle, or angle of edge. As given, this is 56 degrees 20 minutes, and the compound rest is reset to read to the required angle. In this operation, sufficient stock is removed to bring this surface up to an edge with the one previously formed. Note that in all the operations the tool is adjusted normal to the surface operated on, to obtain the maximum cutting efficiency.

Fig. 5 shows operation No. 4, the finishing of the inner ends of the teeth. As these are parallel to the outer ends, the compound slide remains as set for operation No. 3. Sufficient stock is removed to make the teeth of the length required on the drawing (that is, $1\frac{1}{8}$ inch), and an ordinary steel rule obtains this measurement with sufficient accuracy. Filing or scraping the surfaces puts the blank in readiness, so far as the teeth are concerned, for the milling operations. If the performed operations have been done on a reliable lathe, and care

has been taken in reading the figures on the drawing and the graduations on the compound slide, the blank must agree with the drawing. It is well, however, to check the angles with a protractor, and Fig. 6 shows this. While the blank and the tool would ordinarily be held in the hands when making this test, for convenience in photographing they are placed as shown.

With the drawing dimensioned as shown, and the operations followed as numbered, it will be noted that so far the greatest simplicity has resulted in the setting of the machine and in the measurements made.

Selecting the Cutter.

The tooth cutting operations are made in the milling machine, but the points to be brought out will apply to gear-cutting machines as

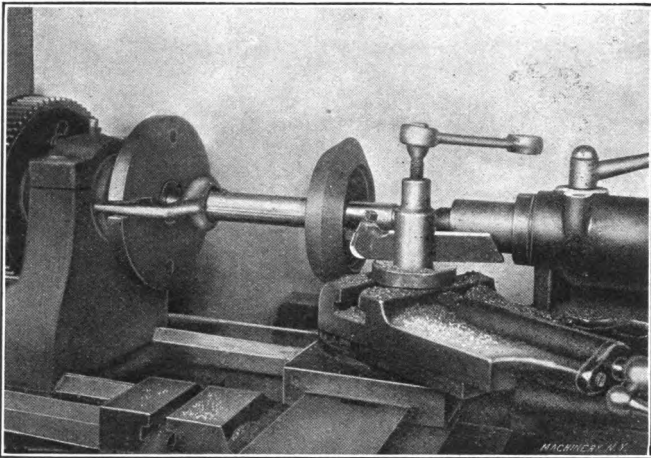

Fig. 5. Turning the Inner End of the Teeth.

well, with slight modifications due to the different mechanism. There are in use at least four different methods by which the machines may be used to form the teeth, and as all bevel gears cut with a rotary cutter must be in error, some latitude as to means can be allowed the workman. For the pair of gears shown, the diametral pitch at the large end of the tooth is 6, since the gear has 36 teeth, or 6 teeth for each inch of the largest pitch diameter. At the inner end of the gear the pitch diameter is much less. The number of teeth is the same, however, and thus the pitch is finer; or, in other words, there are a greater number of teeth per inch of pitch diameter. Suppose, for example, that the pitch diameter at the inner end of the teeth is four inches, then the number of teeth per inch would be nine, and the pitch would therefore be nine, or, as it is commonly written, 9 P.

In choosing a cutter with which to form the teeth, it will thus be seen that if it is the right pitch for one end of the teeth, it must be in error for the other, and it is for this reason that all bevel gear teeth cut by milling are at the best a compromise for the true shape.

As noted above, there are four methods of compromising, but the one chosen for illustration here is that usually termed the "rolling method," meaning that the gear is rolled to and fro for adjustment with the cutter.

To choose a cutter for spur gear cutting, the pitch and number of teeth being given, is a simple matter if the table below, taken from the catalogue of the Brown & Sharpe Mfg. Co., is used. To choose a cutter for milling bevel gears, however, the method given below, and illustrated in the diagram, Fig. 7, is used. Instead of taking a cutter for the number of teeth which one wishes to cut, it may have to be for a much larger number. While this rule is not universally followed and has its limitations, it covers most cases better than any other,

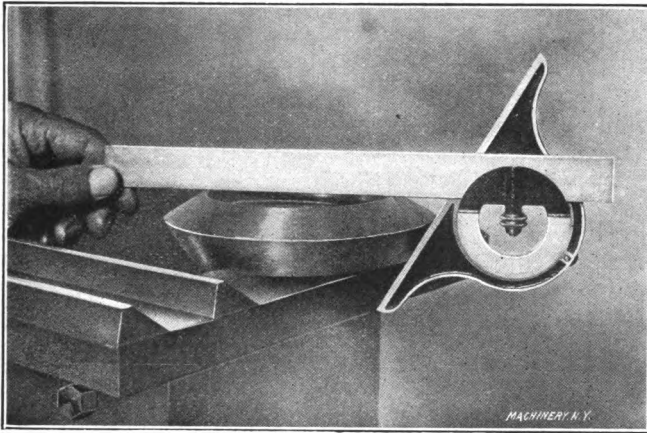

Fig. 6. Testing the Accuracy of the Angles.

and a cutter chosen by this method is the correct curvature for the teeth at the extreme large end, though it cannot have the right curve for the rest of the tooth. It must, also, be so chosen as to be at least as thin as the width of space at the inner end of the teeth. This

RANGE OF CUTTERS IN STANDARD INVOLUTE SERIES.

No. 1	will cut wheels from 135 teeth to a rack.		
" 2	"	55	134 teeth.
" 3	"	35	54 "
" 4	"	26	34 "
" 5	"	21	25 "
" 6	"	17	20 "
" 7	"	14	16 "
" 8	"	12	18 "

makes it necessary to use special cutters, somewhat thinner at the pitch line than those used for spur gears. The method is as follows.

Measuring the dimension in the drawing, Fig. 7, and doubling it, which corresponds to the line *a b*, Fig. 7, and doubling it, gives a length of $10\frac{3}{4}$ inches, nearly. This dimension is, however, not indicated in Fig. 1. Multi-

plying this by the pitch, gives the number of teeth for which the cutter must be chosen, or sixty-four, approximately. In the table on the previous page, a No. 2 cutter is listed to cut from 55 to 134 teeth, and is the one selected. When it is inconvenient to measure the back cone radius, use is made of the following formulas, taken from Brown & Sharpe Mfg. Co.'s catalogue (see Fig. 7 for notations):

$$\tan \alpha = \frac{N_a}{N_b} \quad (1)$$

$$\text{No. of teeth for which to select cutter for gear} = \frac{N_a}{\cos \alpha} \quad (2)$$

$$\text{No. of teeth for which to select cutter for pinion} = \frac{N_b}{\sin \alpha} \quad (3)$$

If the gears are miters, or alike, only one cutter is needed. If one is larger than the other two cutters may be needed.

Setting-Up the Work for Trial Cuts.

The cutting angle of the gear is 53 degrees 40 minutes, given from the center line of the gear, which corresponds to the center line of

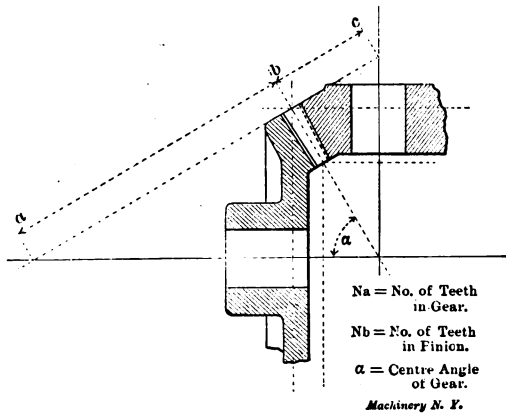

Fig. 7. Diagram Showing Method of Selecting Cutters for Bevel Gears.

the index centers. The index head is therefore swiveled in the vertical plane to the position shown in Fig. 8, or through an arc of 53 degrees 40 minutes by the graduations. The cutter is placed in cutting position upon the milling machine arbor, which must run true. Fig. 9 shows how the cutter and the index center are brought into alignment by adjusting the cross slide. Most makes of cutters have a center line scribed on the tops of the teeth, or on the back face, to set the center to in making this adjustment. Be sure that the center runs true. It is best to try it with a test indicator. The gear blank, as shown in Fig. 10, is mounted firmly on a special true-running arbor, with a taper shank to fit the index head.

Fig. 8 also shows the index pin and adjustable sector set for spacing

thirty-six teeth on the blank. Although use can be made of the printed table which comes with the milling machine to learn the turns and parts of turns to make when indexing, a very simple calculation gives it, when the number of revolutions which must be made with the index crank to give the work a complete turn is known. In most milling machine index heads, this number is 40, as they have a

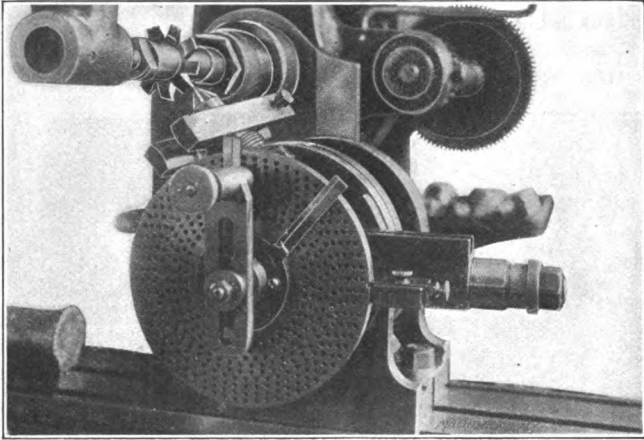

Fig. 8. Spiral Head Set for Proper Cutting Angle and Indexing.

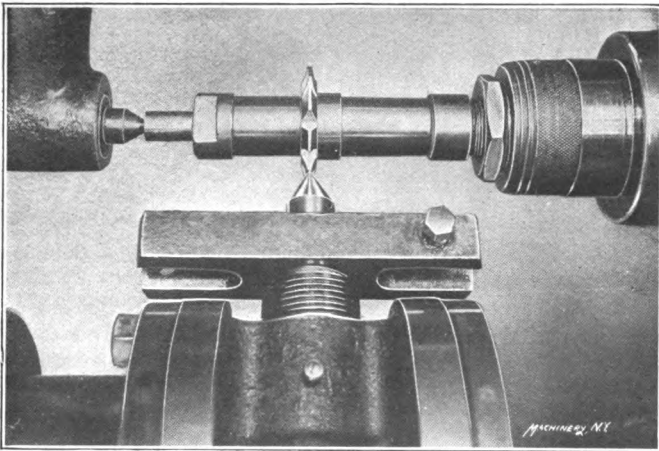

Fig. 9. Setting the Cutter Central with the Work Spindle.

40-toothed worm gear and a single-thread worm; 40, then, is the numerator of a fraction, the denominator of which is the required spacing; or, in other words, dividing forty by the number of spaces required gives the number of turns and parts of a turn of the index crank. In this case, $40/36 = 1 \frac{4}{36} = 1 \frac{1}{9}$ revolutions, or one turn and one-ninth of a turn. Six holes in the 54-hole circle is taken to give

the one-ninth of a turn required. Any circle of holes evenly divisible by nine, can, of course, be used.

With the blank set to the required cutting angle, the next step is to make a line on its back edge showing, as in Fig. 10, the depth of the teeth at this point. This is done with a "depth of gear tooth" gage of the proper pitch. Such gages may be bought in different sizes for different pitches. Be careful to hold it parallel to the back edge of the blank when scribing the line.

Fig. 11 shows the machine and work completely set up, and adjusted for the trial cut. This cut must not be so carelessly made as to be

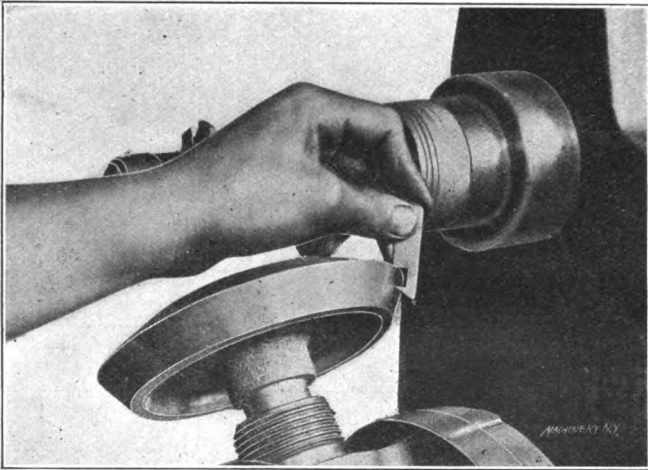

Fig. 10. Marking the Depth of Tooth with Depth Gage.

deeper than the tooth depth line marked out in Fig. 10, and several trial cuts, each deeper than the other, may well be made in getting the required depth for the first space.

Approximating the Correct Tooth-Form by Rolling.

Fig. 12 shows the first space cut to depth. The work is then indexed for another cut. Fig. 13 shows the trial tooth left by the two trial cuts completed. It is noticeable that the tooth is much wider on the pitch line than it should be, at the outer end. This may also be true of the inner ends at the pitch lines, and is certain to be true of the inner ends above the pitch line when the gear is finished, unless this part of the tooth is afterward filed somewhat. The coarser the pitch and the longer the tooth face, the more this latter shows. The rolling method of approximating the true tooth shape starts by making several central cuts, such as shown in Fig. 14, giving teeth which may be used to test adjustments by as they are made. With the cross feed index set at zero, the table is moved off center toward the column of the machine a trial distance, and then clamped immovably. By means of the index crank, the work blank is rotated or "rolled" back toward the cutter again to just admit it to the space at the inner end of the

teeth. Do not disturb the adjustable sector when doing this, but leave it to mark the hole which is correct for the central position.

Rolling the gear is equivalent to swiveling the tooth about the apex of the cone, and allows the cutter to take a heavier shaving or chip

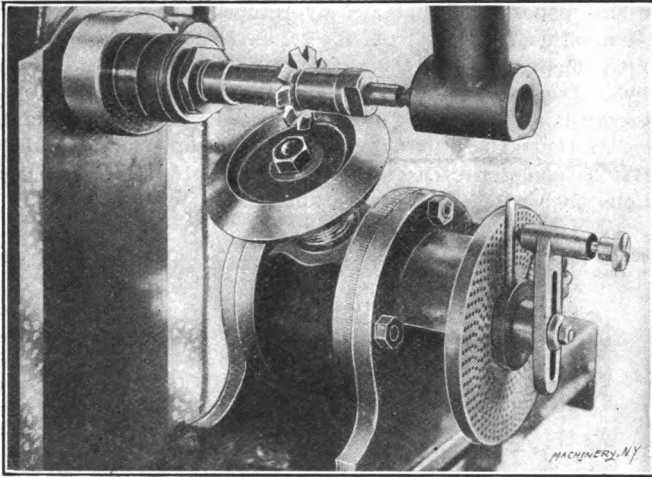

Fig. 11. Work in Place on Machine, Ready for Trial Cut.

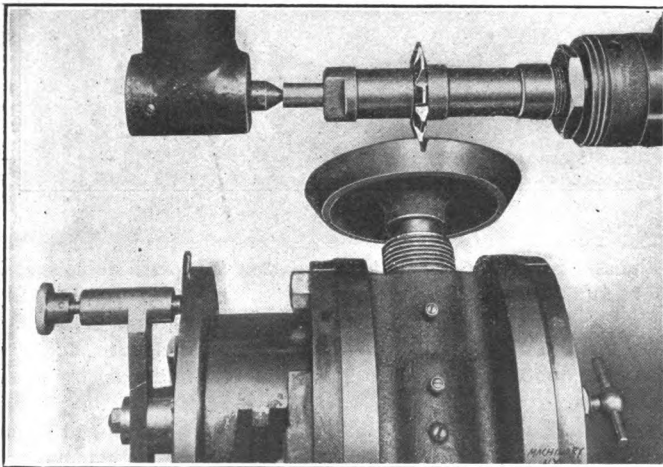

Fig. 12. Trial Cut Completed.

at the outer end of the tooth than it does at the inner end. The greater the adjustment off center and the more the blank is rolled, the greater this difference.

If, for example, the cutter leaves the trial teeth accurate in thickness at their inner ends, the blank would be rolled, when making adjustments, to allow the cutter to just enter the trial cut at that

end without thinning the teeth. Exceptions to this will be noted further along.

After the trial cut has been taken upon one side of the tooth, the index pin and the cross slide should be returned to their original central position, and the blank indexed one tooth, to bring the cutter to the side opposite to that already thinned off. Afterward set the cross slide off center *away* from the column, and roll the blank toward the cutter again, the same amount as before, until the cutter just enters the space at the inner end. Thin off this side. If the larger end of the tooth is still too thick, it shows that the cross slide was not set off from its central position a great enough distance, and another trial cut must be made on each side of the tooth, carefully duplicating the operations just noted, but giving additional movement to the cross

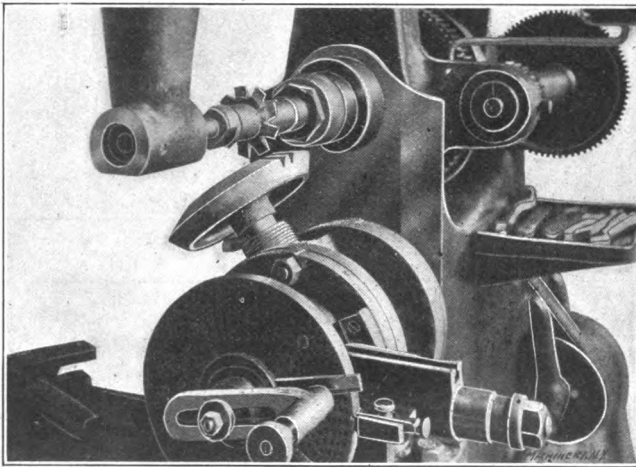

Fig. 13. Trial Tooth Formed by Two Trial Cuts.

slide and the rolling of the blank, repeating this until the gage shows the right thickness at the outer end of the teeth as in Fig. 14. The gage shown is one of a form common in gear cutting practice. The notch in the end of it has a depth equal to the addendum, and a width equal to the tooth thickness of the pitch for which it is intended—6 in this case.

As previously stated, all this has been done on the supposition that the thickness of the cut left the space and teeth at their inner ends the right width. If the cutter is too thin to do this, the teeth must be shaved on their sides at the smaller as well as at the larger ends. It is then necessary to observe that neither end is cut too narrow, and the cross-slide adjustments, as well as the rolling of the blank, must allow for shaving the tooth its entire length.

In the gear shown, the cutter was considerably thinner, and the tooth was shaved its entire length. In making the trial cut, the cross

slide was offset 0.010 inch, and the blank rolled four holes in the 54-hole circle, and the trial tooth shaved upon both its sides. These amounts were afterward increased to an offset of the cross slide to 0.015 inch each side of the zero line, and seven holes in the 54-hole circle. This gave a tooth that gaged up as desired at its inner and outer ends on the pitch line.

If the teeth of the pinion are not to be filed at their inner end above the pitch line to bring that portion of the tooth more nearly to correct shape than the cutter will leave it, it may be necessary to widen the space at the inner ends of the gear to give additional room. On the finer pitches, the cutter leaves the teeth so nearly correct that they need not be filed; but in the coarser pitches, filing is quite necessary.

Cutting the Teeth.

Having established the amount off center, and the angle to roll the blank, proceed to cut the rest of the teeth. If the pitch is rather

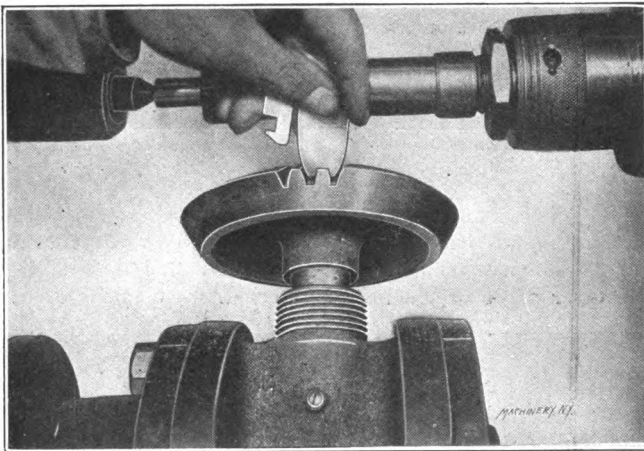

Fig. 14. Testing Accuracy of Settings for Approximating the true Tooth Form.

coarse, three cuts may be necessary all the way around each blank. In the finer pitches, however, two cuts around are sufficient. In the case of three cuts, the first is a central cut made as already shown with the standard cutter, all the way around, and then the two thinning cuts follow. Some gear-makers use a so-called "stocking cutter" in making the central cuts, afterward thinning the teeth with a standard cutter as noted. This undoubtedly leads to less sharpening of the standard cutter.

If the pitch allows two cuts around the blank to be sufficient, the first is, of course, made with the table offset and the work rolled to shape one side of the teeth, and the second, with the machine and work set to shape the opposite side, each cut going all around the blank.

Figs. 16, 17 and 18 show the cross-feed screw index dial, as adjusted for the central cuts, and afterward the thinning cuts.

Fig. 15 shows the amount that the space is wider than the cutting edge of the cutter; and Fig. 19 is a general view of the entire machine as set up.

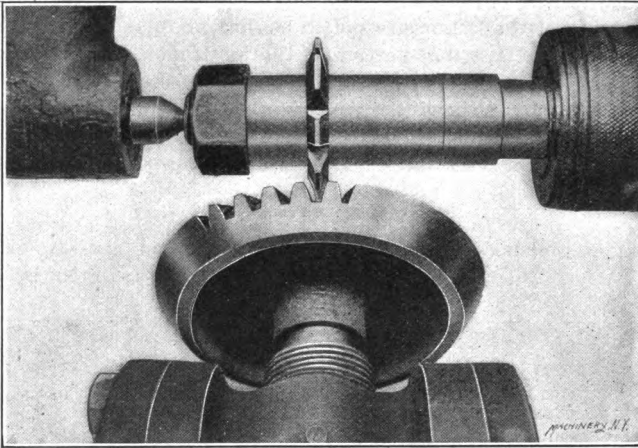

Fig. 15. Cutter Completing the Tooth, Showing Widened Tooth Space.

General Directions.

In closing, it may be well to note some precautions: Mounting the work as shown, with all "overhangs" as short as possible, still leaves the outer end unsupported. Care must therefore be taken to have the taper arbor in the index head well fitted and driven firmly

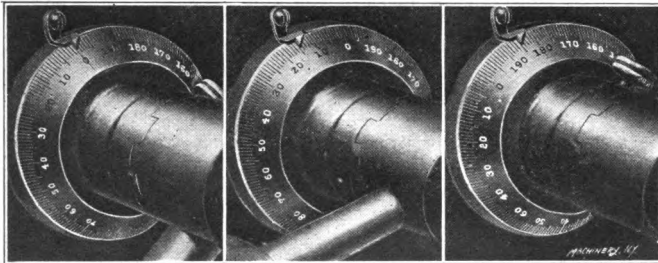

Fig. 16. Cross-feed Dial when Work Spindle is Set Central.

Fig. 17. Cross-feed Dial Set for Cutting Outer Side of Tooth.

Fig. 18. Cross-feed Dial Set for Cutting Inner Side of Tooth.

in place; the work must also be mounted upon the outer end of the arbor so that it will not slip under the action of the cutter.

The cutter must be carefully ground sharp, with each cutting edge radial and exact, relative to the center hole. The cutter must also be in coincidence with the center line of the index centers or the teeth will "hook," relative to the apex of the cone as well as to the radius.

In making adjustments of the cross-slide or with the index pin, see that the final motions are always in the same directions. This prevents errors of adjustment due to lost motion or backlash. For example, in Fig. 16 the zero setting was made by moving the cross-feed handle to the right until the dial read to the zero mark. That shown in Fig. 17 was a continuation of this motion, and in Fig. 18

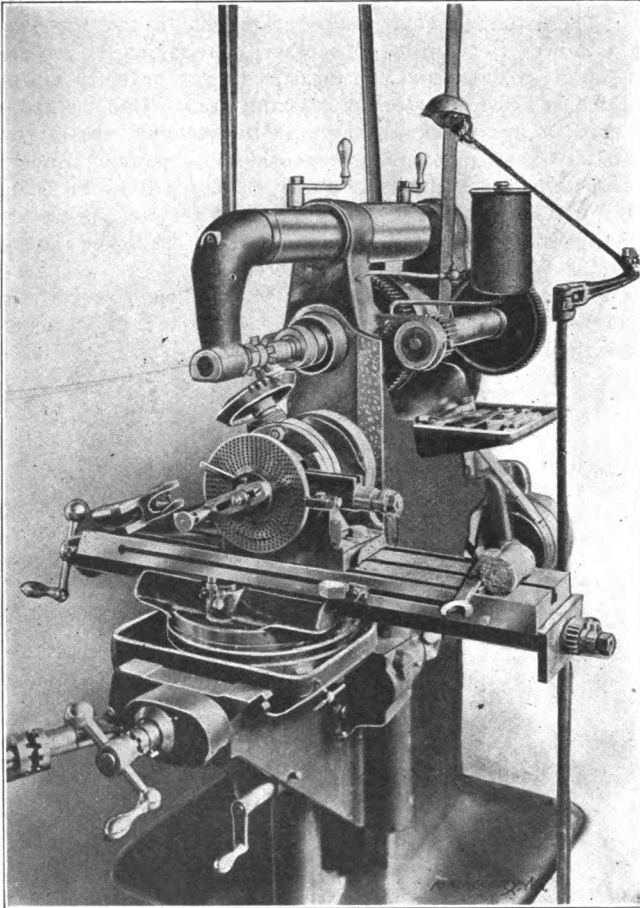

Fig. 19. General View of Machine as Arranged for Cutting Bevel Gears.

the handle was reversed at least a half revolution, and then turned in a right-hand direction to the required graduation. All milling machines and index heads are provided with means of clamping the several sides and swivels, and these should always be tightened while the cut is being made, and, of course, loosened when adjusting. After the indexing for a cut, place the counting sector in readiness, as shown in the cuts, for the next adjustment.

In turning up the blanks, machine an extra one to use as a "dummy" for setting the machine. This dummy may be used until cut up. Finally, settle upon a regular order of operations, follow it until a habit is formed, and fewer errors will result.

As has been intimated, the method of cutting bevel gears just described, is only an approximate one. There is no possible way of cutting them to the theoretically perfect shape with formed milling cutters. There are probably more gears cut in the way we have described, however, than by any other method, as it requires the simplest outfit of tools, and can be done in any ordinary milling machine which is provided with an indexing head. This method should not be used on large gears—especially those which are to run at a high rate of speed and transmit considerable power. Under these conditions, bevel gears cut with rotary cutters will be inefficient and noisy, and will be far from durable. For such service, the teeth should be planed by some one of the various machines made for the purpose, either by the templet or generating processes.

There are so many gears cut with this method, however, that the ability to use it should be a part of the training of all machinists who class themselves as "all around" workmen.

CHAPTER II.

MAKING A WORM-GEAR.

The machinist is apt to concern himself but little with the steps taken by others to produce the castings which he is given to finish into machine parts. He seldom gives the designer or draftsman a thought,

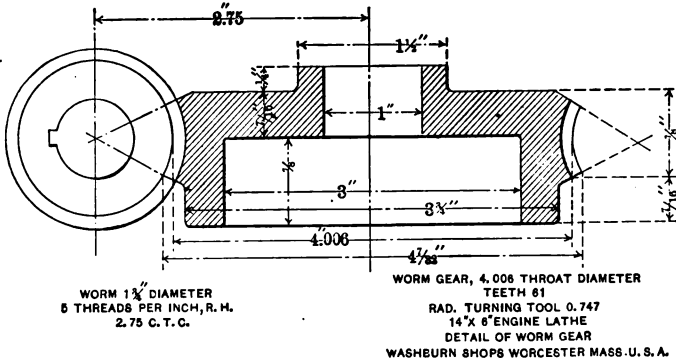

Fig 20. Drawing of the Worm-Gear to be Made.

and the patternmaker or molder gets less. It may therefore be of interest to follow along the path a piece has taken from its first inception in the designer's brain, to the point where it becomes a finished

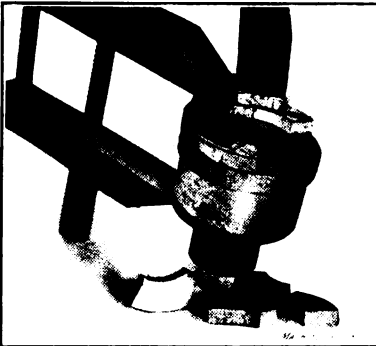

Fig. 21. Gluing Up the Pattern for the Worm-Gear.

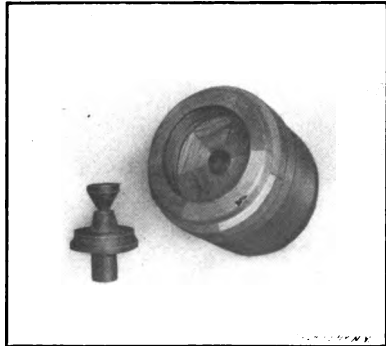

Fig. 22. The Hub and Finished Face of the Pattern.

part of a useful machine, and to count the footsteps. Take, for example, a worm-gear such as that shown in Fig. 20, which is part of a friction feed mechanism. Topsy "just grew," but this is not true

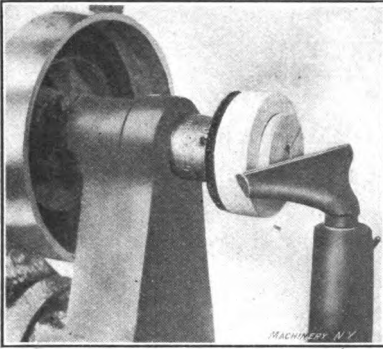

Fig. 23. Turning the Wood Chuck.

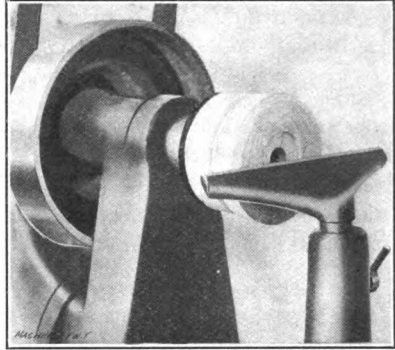

Fig. 24. Turning the Seat for the Hub.

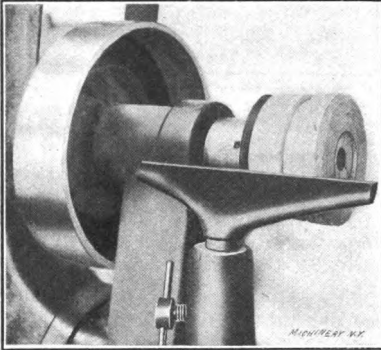

Fig. 25. The Seat Completed.

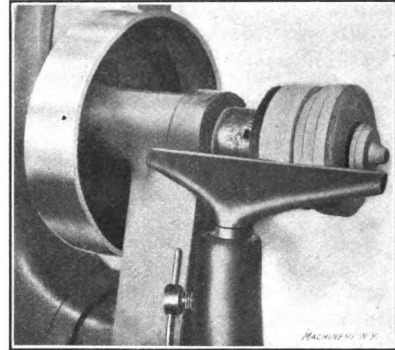

Fig. 26. Trying in the Hub.

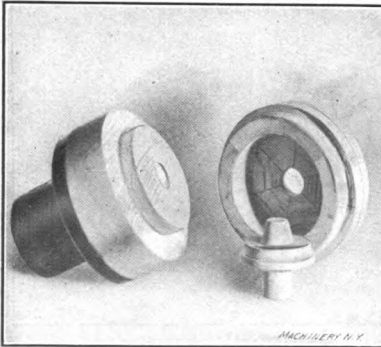

Fig. 27. The Completed Body and Hub.

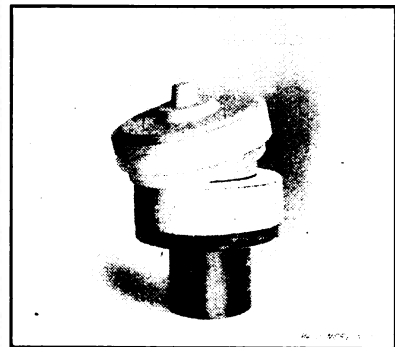

Fig. 28. The Assembled Pattern.

of a machine part, either in design or workmanship, and even so simple a piece as the one shown represents thought by the designer, patternmaker and foundryman. The designing draftsman should be

something of a patternmaker, foundryman and machinist, in addition to his ability to assign proper values to form, strength, velocity ratios, position, etc. On the work of the draftsman depends largely the possibility of economic production in the shop, and if the machine

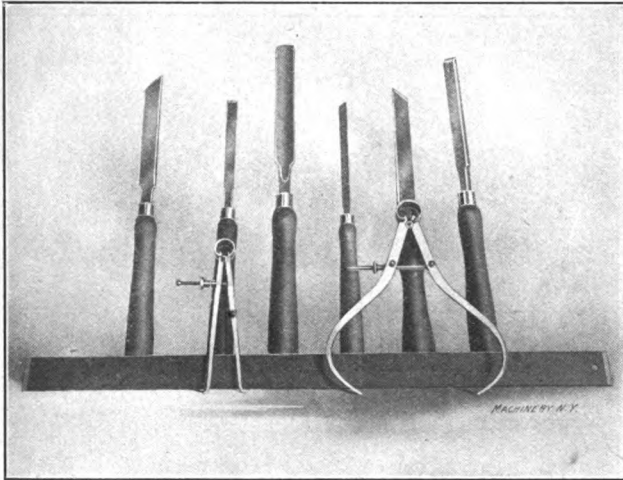

Fig. 29. Tools Used by Patternmaker.

details he designs cannot be easily and cheaply made, it is, in most cases, his lack of proper understanding of shop processes, which is to blame for this condition.

The patternmaker is concerned with questions of shrinkage and warping of the materials used in making the pattern. He is also

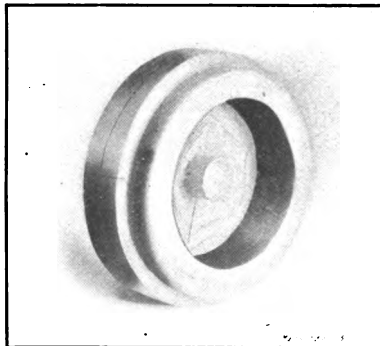

Fig. 30. Pattern Finished and Shellacked.

concerned with the foundry and machine shop problems of shrinkage, draft, finish, ease of molding and machining Fig. 21 shows the best method of gluing up a pattern to provide for uniform shrinkage, prevent serious change of form by warping, and give strength.

Such a pattern finishes nicely under the cutting tool, as shown in Fig. 22. The core print and hub are, however, turned from the solid and afterward glued into place.

Wood mounted on a face-plate and afterward used to hold work by gluing, shouldering, recessing or any similar manner is termed a

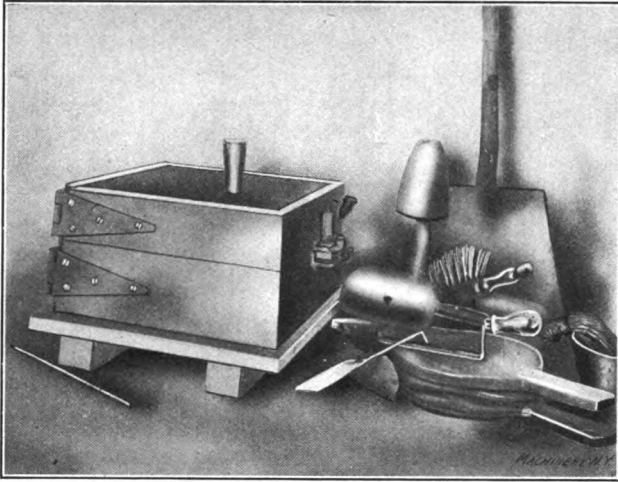

Fig. 31. The Mold and the Molder's Tools.

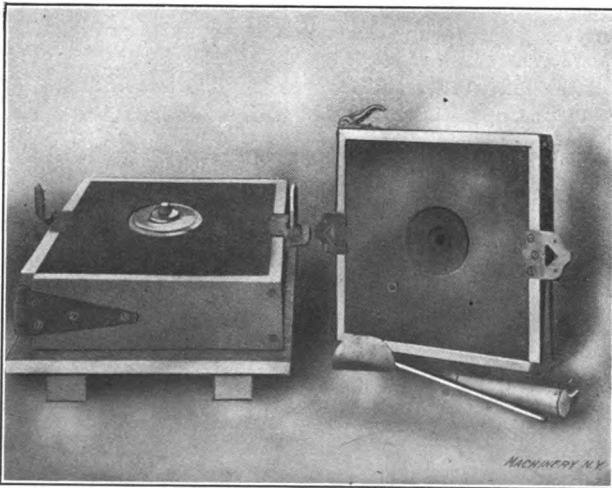

Fig. 32. Ready to Draw the Pattern.

wood chuck, and Fig. 23 shows the turning of the wood chuck to fit the recess in the pattern. The pattern is held to the wood chuck by strips of paper glued between the face of the chuck and the pattern; this permits the pattern to be removed after the turning of the seat for the hub, which operation is shown in Fig. 24.

Fig. 25 shows the tool rest swung to a position that allows the hub to be tried into the recess, as in Fig. 26. Fig. 27 is the pattern removed from the chuck with the hub and core prints ready for gluing into place. This is done in Fig. 28, and in Fig. 30 the pattern is shellacked

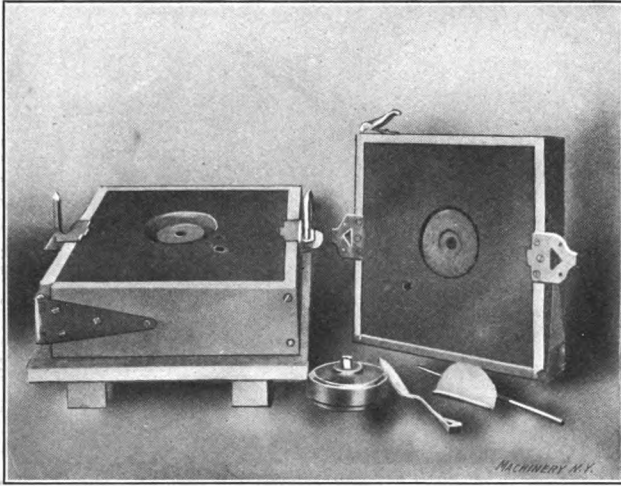

Fig. 33. The Pattern Drawn.

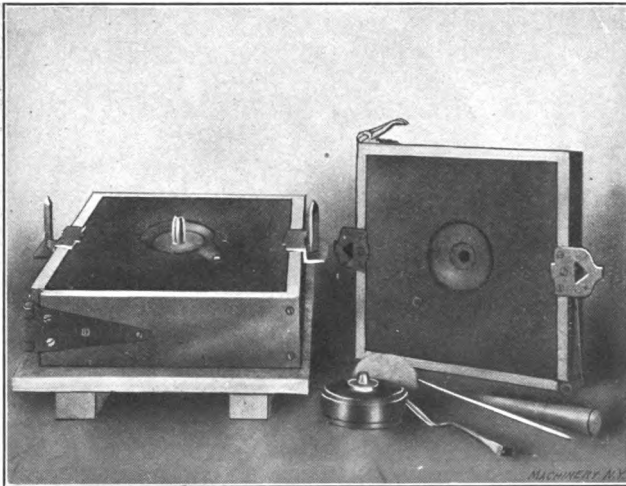

Fig. 34. The Core in Place, ready for the Cope.

ready for molding. The tools used by the patternmaker appear in Fig. 29.

Considered from the viewpoint of the foundryman, a pattern is a useful but not an indispensable tool, and with it he can more easily

produce the required castings. Such a pattern as the one shown makes a simple molding job, if a molding job of any sort can be termed "simple." In Fig. 35 are the two parts of a flask made hinged so as to be snapped open by the molder to remove them from the sand mold,

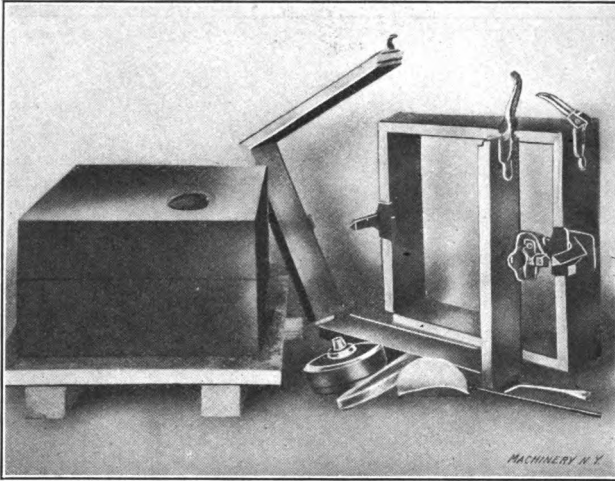

Fig. 35. The Completed Mold.

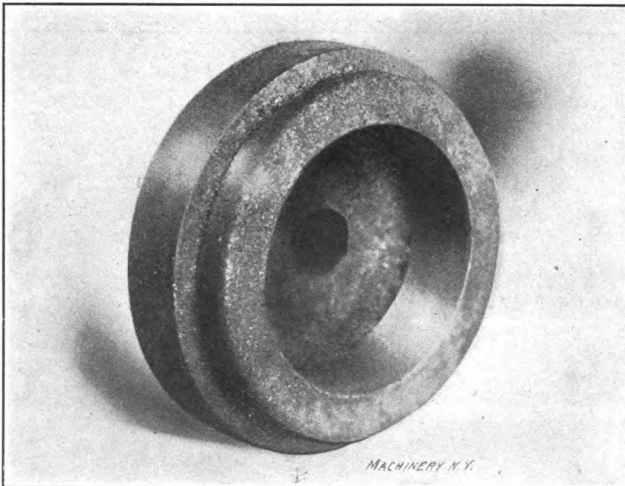

Fig. 36. The Rough Casting.

and in Fig. 31 is the sand mold complete with the taper plug that forms the gate in place. Some of the tools used by the molder are shown in this view. For convenience in handling the upper and lower parts of the flask—termed the *cope* and *nowel*—as much of the pattern as its shape will allow is bedded into the nowel, as in Fig. 32.

With the pattern withdrawn as in Fig. 33, a cavity is left for filling with the melted metal. As a portion of the cavity is in the cope, the flask needs to be closed when poured. To lead the metal into the cavity made by the pattern, a gate is cut beside it out to that left

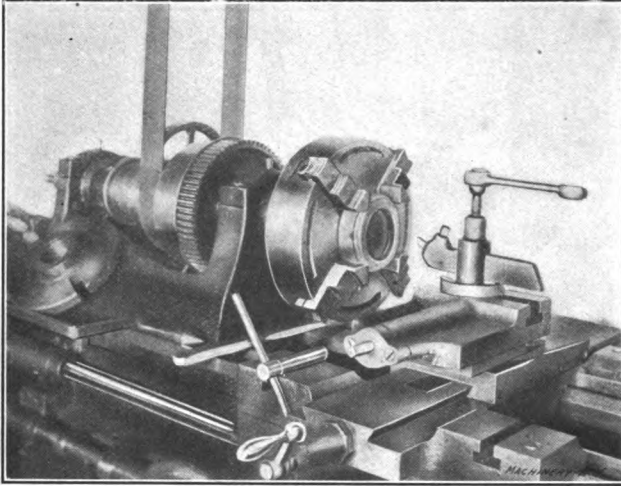

Fig. 37. Truing Up the Casting in the Chuck.

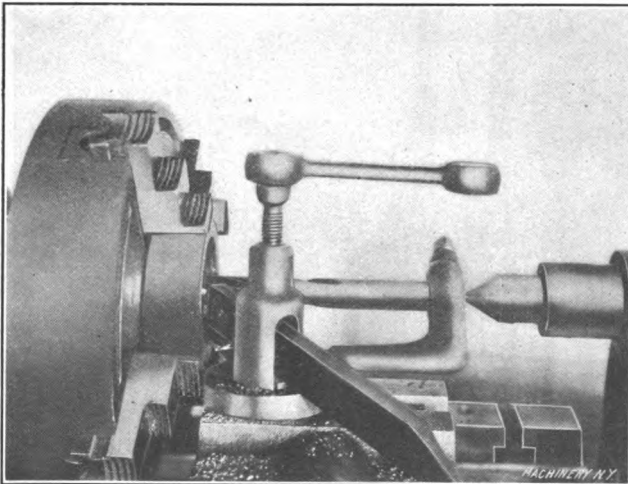

Fig. 38. Drilling Out the Hole.

by the tapered plug. This is shown in Fig. 34. To form a hole in the center of the casting, a sand core is placed in that part of the cavity left by the core prints, and the mold is closed and the flask removed. The mold now presents the appearance of Fig. 35, and is ready for

pouring. It will be seen from this figure that the outer part of the gate has been enlarged to form a basin into which the molten metal can be conveniently poured. After the mold is poured, the sand is broken apart, and the casting is allowed to cool until it is ready to be

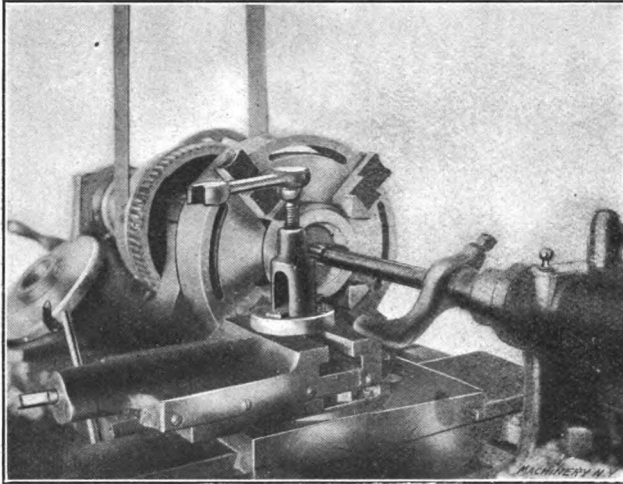

Fig. 39. Reaming the Bore.

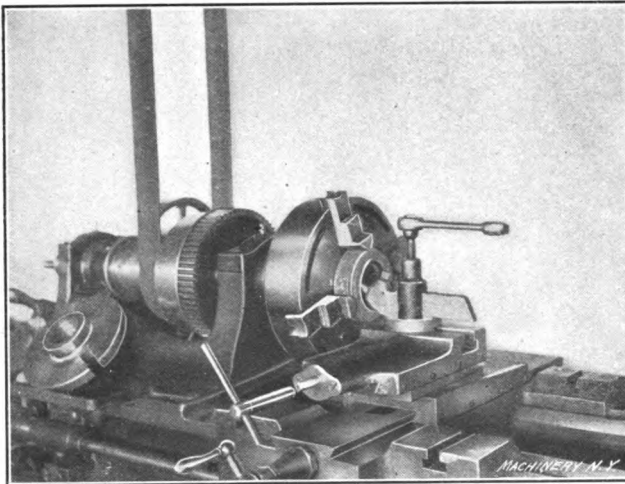

Fig. 40 Roughing the Bottom of the Recess.

placed upon the pickling bed and prepared for the machine shop processes, and appears as in Fig. 36.

The first operation on the casting in the machine shop is to true it up in a lathe chuck and finish out the hole. To insure a satisfactory hole three tools are used; a drill, lathe reamer, and hand reamer, in

the order named, each tool leaving the correct amount of stock for the succeeding one. To indicate the position of eccentricity when truing up the piece in a chuck, either chalk or a lathe tool may be used. Fig. 37 shows the piece ready to be drilled and lathe reamed, Fig. 38 and

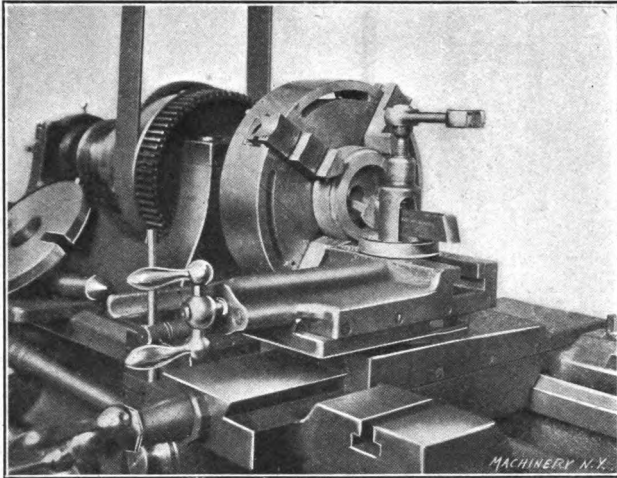

Fig. 41. Finishing the Recess.

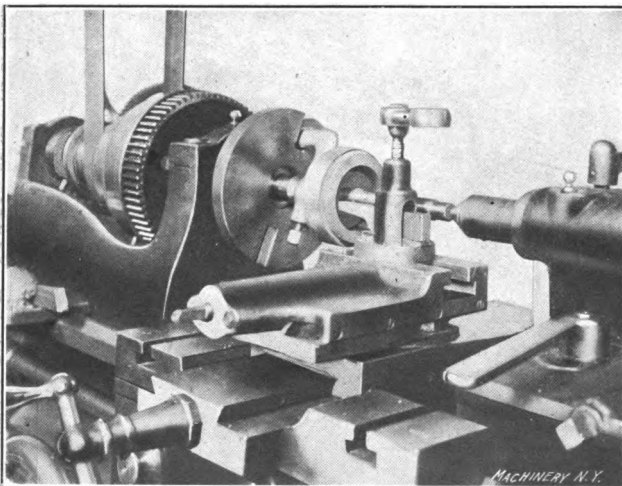

Fig. 42. Finishing the Inner Circumference.

Fig. 39 completing the operation. If the drill tends to wobble when it is being started, the butt end of a lathe tool held as in Fig. 38 steadies it. The bottom surface of the recess can be more easily finished when held in the chuck than afterward. Figs. 40 and 41 show this being

done. The outer edge is squared first for convenience in scaling the depth of the recess.

Fig. 42 illustrates the finishing of the internal circumference true with the hole. While it would be good enough practice to rough out

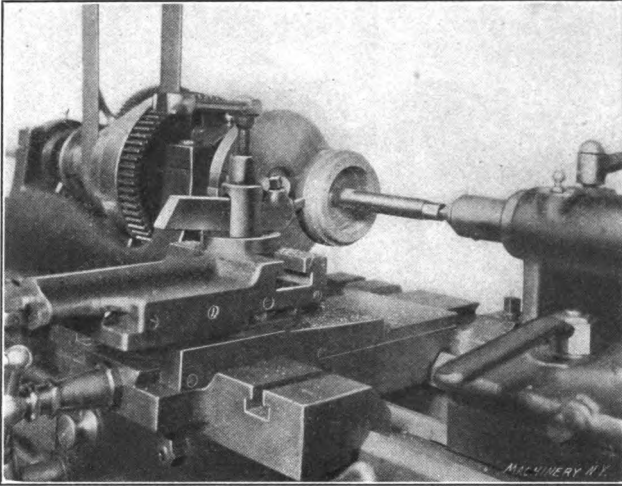

Fig. 43. Rough Turning the Outside Diameter.

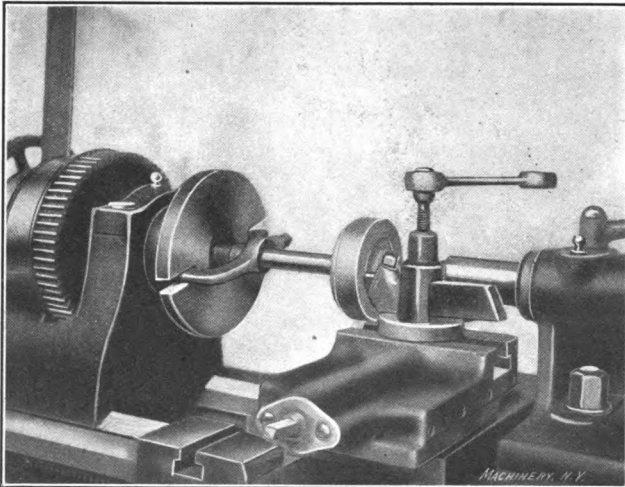

Fig. 44. Roughing the Outer Face.

and finish this surface while the piece was held in the chuck, in order to introduce the method employed for work where a high degree of accuracy is required, this operation has been shown carried out with the work on a true running mandrel.

In roughing out and finishing the outer circumference, as in Fig. 43, the concaved surface for the teeth is left as the roughing tool leaves it. Roughing the outer worm-gear face, as shown in Fig. 44, is best done by feeding from the outside toward the center, as the hard skin

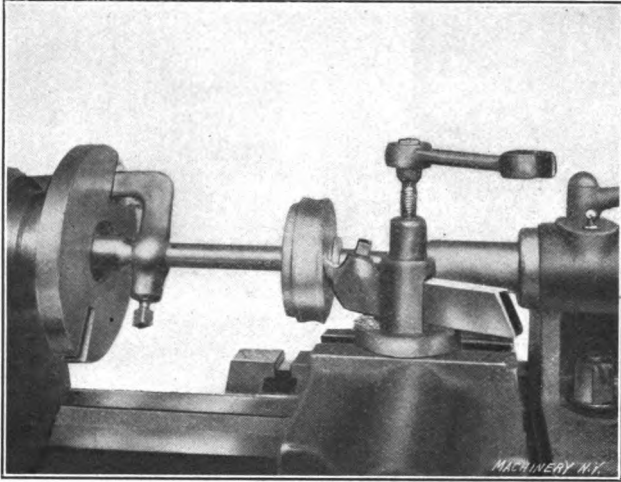

Fig. 45. Finishing the Face with a Scraping Cut.

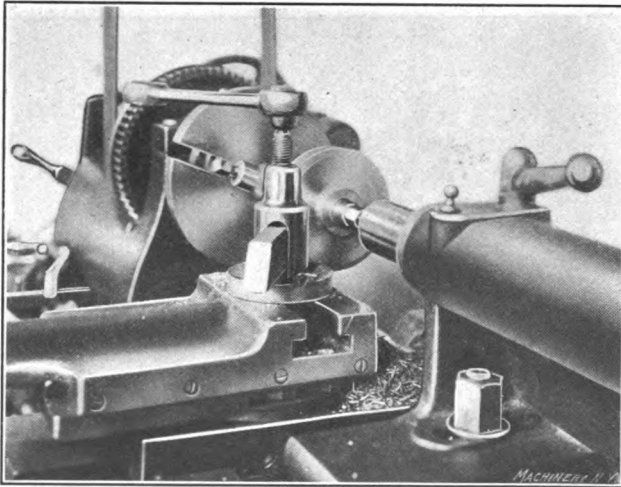

Fig. 46. The Finished Surface.

or scale of the casting is pried off or crumbles ahead of the cutting edge. Finishing this surface is done by lathe scraping, which leaves a smooth, polished surface. For this purpose the tool is fed in the reverse direction from that of roughing, or from the center outward. Fig. 45 shows the method and Fig. 46 the results.

The concave surface upon which the teeth are cut is easily made, as in the illustration, Fig. 47, by means of a radius tool. If a comparatively slow speed is used and a firm, steady feed, the tool will not give trouble by chattering. The fact that such a tool removes actual

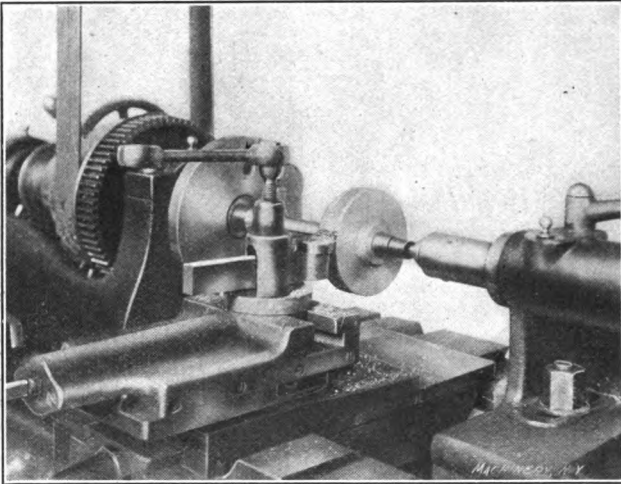

Fig. 47. Radius Tool for Tooth Surface.

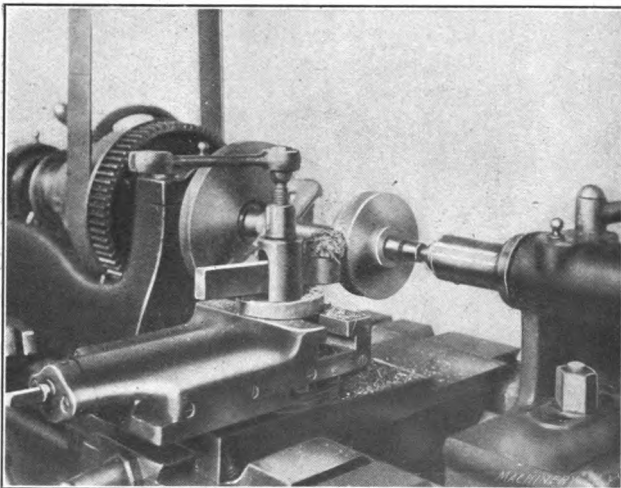

Fig. 48. Chips made by Radius Tool.

shavings when properly used is clearly shown in Fig. 48. When the corner has been beveled or chamfered, as in Fig. 49, the piece is ready to have the teeth cut on its circumference. Before doing this it may be well to consider briefly the way in which the teeth *may* be cut.

Worm-gears used as adjustments do not need to have other than line contact between the teeth of the worm and gear, and suitable teeth may be formed by using a single cutter of the proper curvature. This is very clearly shown by the Brown & Sharpe Mfg. Co., in their treatises

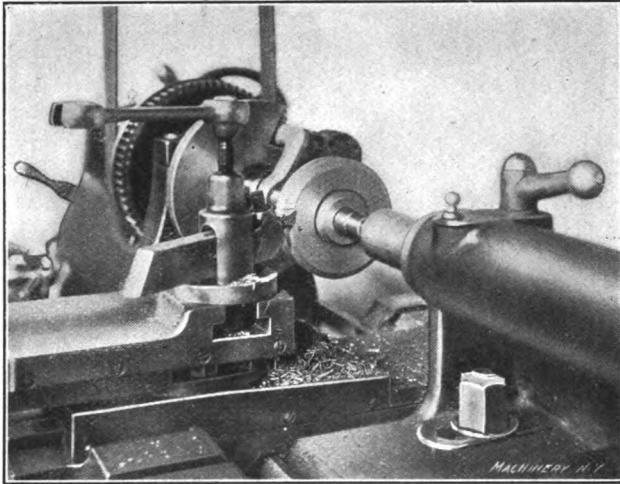

Fig. 49. Chamfering the Corner.

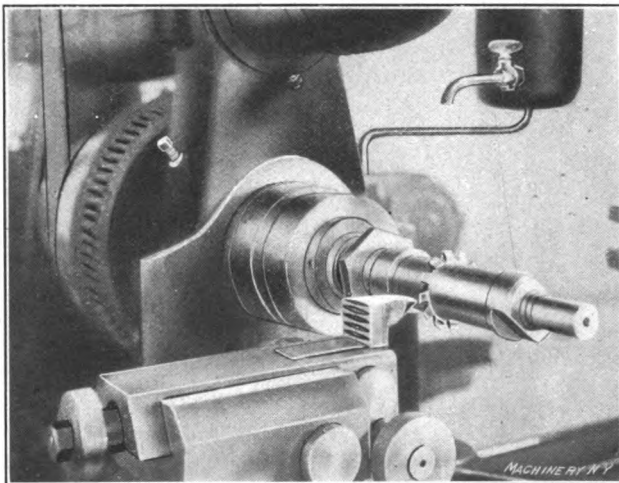

Fig. 50. Centering the Gashing Cutter.

on gears and the milling machine. Where, however, the worm and gear are used to move a load, as in the case of a feed worm drive, surface contact between the teeth is made necessary. To obtain this, they are formed by a cutting tool termed a "hob," and the operation

is called "hobbing." If the hob is allowed to space the teeth without previous "gashing" it will cut a larger number of teeth than is desired upon the given circumference. Gashing prevents this, and can be done by using any cutter that will leave enough stock upon the sides of

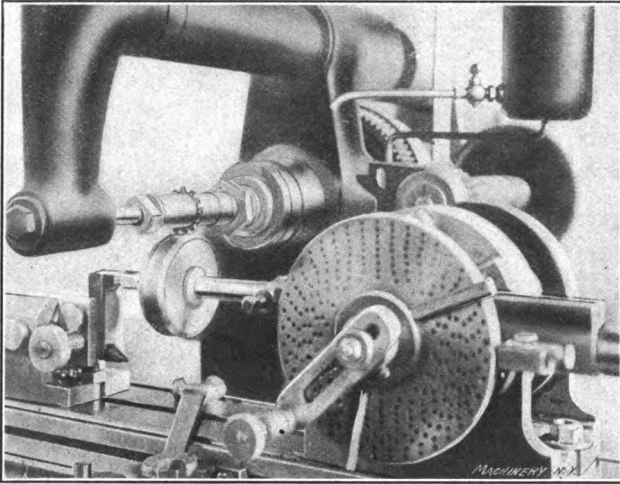

Fig. 51. The Cutter Located with Reference to the Blank.

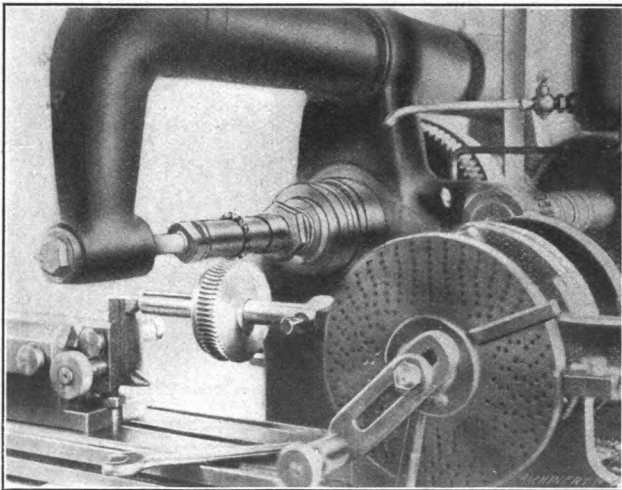

Fig. 52. Gashing the Worm-Wheel.

the teeth to permit finishing by the hob. The gashing cutter may be set central, as illustrated in Figs. 50 and 51. Gashing after the cutter is properly set is a question of indexing the required number of spaces and of feeding the work vertically against the cutter to

give the allowed depth. The worm-gear being a portion of the back section of a nut, its teeth will have a *left-handed* angularity if the worm is *right-handed*. The work table should be swiveled to give this when the blank is gashed, and afterward set to zero when hobbing the

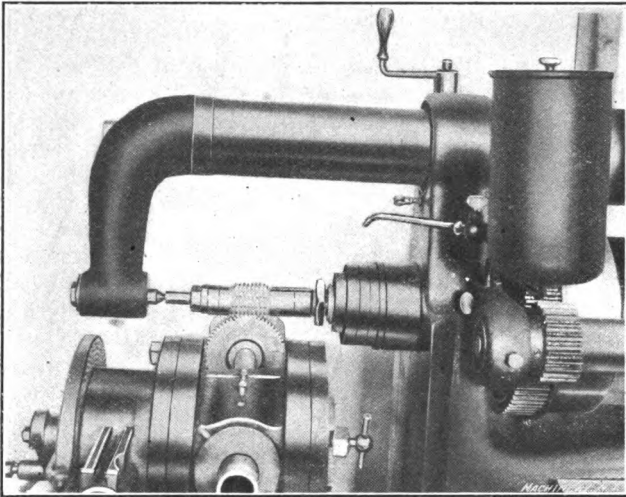

Fig. 53. The Hob in Place.

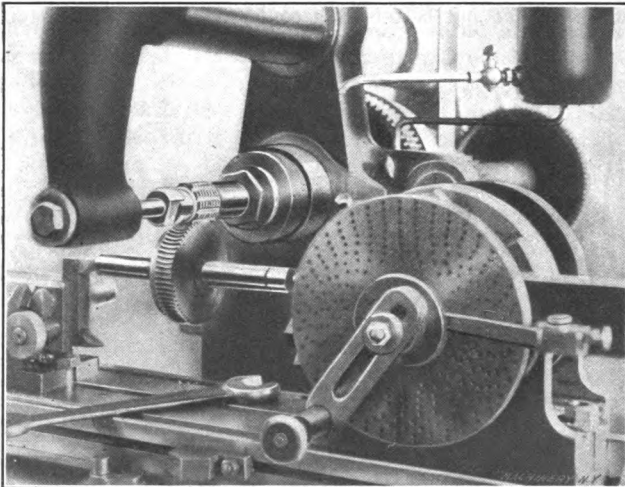

Fig. 54. The Finished Worm-Gear.

teeth. After the spaces have all been indexed as in Fig. 52, the dog is removed from the mandrel and the hob placed in position, as shown in Fig. 53. In this position, and mounted as shown, the hob forms up the teeth and rotates the blank. The feed is vertical as for gash-

ing, and to such a depth as necessary to give the required distance "center to center" of worm and gear. The finished job is shown in Fig. 54, and a general view of the machine in Fig. 55.

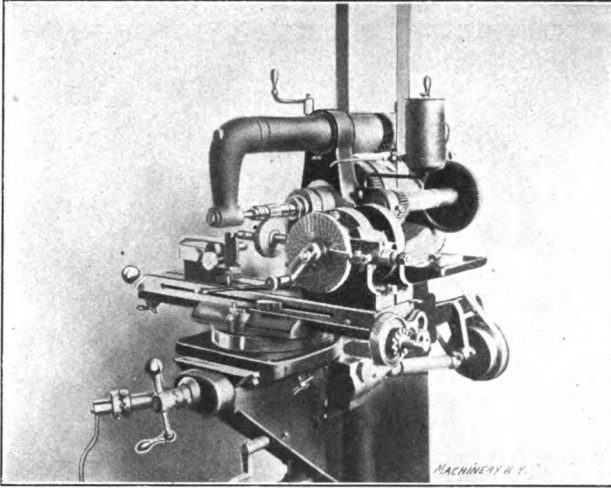

Fig. 55. Milling Machine Set Up for Hobbing.

In the foregoing only a mere outline of the operations has been given in words, the half-tones being depended upon to tell the story of the work carried out better than could an elaborate description.

CHAPTER III.

SPINDLE CONSTRUCTION.

The spindles used in boring mills, drill presses, milling machines, and lathes are usually fitted with a threaded nose, and a tapered hole to hold a collet, an arbor, or a pointed center. Milling machine and lathe spindles are also made with a hole throughout their entire length in addition to the other features. This hole is a convenience in many ways, as it is possible to pass stock to be operated upon through the hole. In the flat turret lathe and in the different makes of screw machines this is the principal method of feeding stock to the several tools held in the turret of the machine.

The spindles of the above-mentioned machines are either made from a good bar of machine or 20-point carbon steel, or they are made from crucible steel forgings of about 50-point carbon, and are commonly spoken of as hammered crucible steel spindles. High carbon or tool steel is used at times for spindle work, but this can be classed as special spindle work, and its use is rare. The requirements of spindle construction are that the spindle be perfectly straight, that the journals be round, straight, and true running, that the nose be threaded to run true with the journals, and that the tapered center hole also run perfectly true with the journals. The spindles in any of the first-class machines are constructed to fulfill all these requirements to a remarkable degree. Several makers, for example, test the truth of the tapered hole with a test bar of at least one foot in length, and allow a vibration of less than 1-1000 of an inch from truth at the outer end of this test bar, a severe test when one considers that these are not special machines, but are regular commercial products.

Tools Used in Spindle Boring.

The producing of holes throughout the length of spindles and shafts has led to the devising of machines and appliances for deep drilling that are peculiar to such work. To commercially drill spindles at a profit requires that the maximum feed be maintained. It is a matter largely of furnishing a free cutting tool, amply lubricated and cooled, and keeping the hole free from the cuttings or chips. No method that does not fulfill the above conditions can be said to be a complete success. Where, however, but few spindles are to be drilled, and when the number does not warrant the purchase or construction of special spindle drilling machinery, the engine lathe or a drill press can be used to do the work. Owing, however, to the difficulty of keeping the hole freed from chips when the work is held vertical, the lathe is the tool or machine mostly used for this drilling job. The drills used in deep drilling of this kind are the ordinary twist drill, Fig. 56, the oil tube twist drill, Fig. 57, the straight flute or "Farmer" drill, Fig. 58,

the half-round drill or hog nose drill, Fig. 60, and the special hollow drill, shown in Fig. 59. This last drill is used in a special drilling machine, as a rule, and not in ordinary lathe drilling.

Where only a few spindles or shafts are to be drilled, the common twist drill, shown in Fig. 56, or the straight fluted drill, shown in Fig. 58 are used. As they are ordinarily made of much shorter lengths than the hole to be drilled is likely to be, some means must be used to lengthen them sufficiently to allow of the reach desired. This can be accomplished by first turning the shank end of the drill below size. The stem or shaft to lengthen the drill can be a piece of cold rolled steel of the same diameter as the drill. A hole is made in one end of this stem of a size that will closely fit the reduced shank of the drill. The turned down shank of the drill is then "tinned" with solder and some of the soldering acid is dropped into the hole in the stem. To

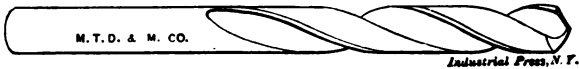

Fig. 56.



Fig. 57.

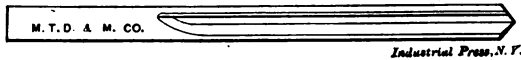

Fig. 58.

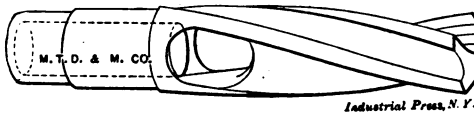

Fig. 59.

Figs. 56 to 59. Tools Used in Spindle Boring.

put the two parts together, grasp the drill next to the reduced end with a pair of gas pipe pliers, and by holding the tinned end of the drill and the drilled end of the stem in a Bunsen flame, they can, when heated sufficiently to make the solder run, be forced together. When cool they will be capable of withstanding great stress. This process is termed in the shop "sweating in" a drill.

Where the hole which is to be drilled is of such a depth relative to its diameter as to make the length of shaft or stem so great that it will be too slender to use when the hole is first started, several stems of varying lengths may be provided. The process of sweating on these stems is so simple that one stem when used to its depth can be unsoldered and another and longer one sweated into its place. The holding of the drill in a hand vise or pipe pliers when soldering insures keep-

ing the flutes cool beyond the part so held and the hardness of the cutting parts is not disturbed. In deep drilling with this tool it is necessary to withdraw the drill as often as the flutes are filled with chips, to allow of their removal and also to lubricate the cutting edges. As this is time consuming, when many spindles are to be drilled in the lathe, the oil tube drills shown in Fig. 57 are better for the purpose. The oil tubes are joined at the rear end or shank of the drill and are covered by some form of hollow bushing. This bushing is tapped upon, its circumference to take a short piece of gas pipe. A hose connection between this short piece of gas pipe and the oil pump allows the oil to be forced through the oil tubes to the cutting lips.

To allow the chips and oil to force out, two straight grooves are milled on opposite sides of the stem or shaft and connecting with the helical or twisted flutes. To break up the chips and insure their being forced out by the oil, notches or steps are ground in the cutting lips of the drill. These notches must always be of a greater depth than the distance the drill advances per revolution. If the drill is sharpened upon a drill grinding machine, each lip will cut evenly, and chips should come away evenly from each cutting edge. Drill grinders, however, are designed to leave the end of the drill of such a form as will allow it to just clear the bottom of the hole being drilled. As the

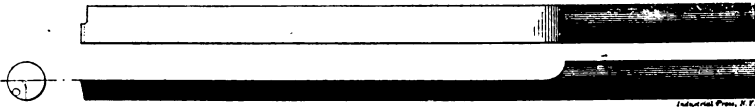

Fig. 60. Half Round, or "Hog-nose" Drill.

oil tubes end in this surface, the oil is prevented by this small clearance from flowing to the full capacity of the tubes, and it is necessary to grind off the back edge of the flute squarely up to the end of the oil tube. This weakens the cutting edge somewhat, but does not do so to an extent worth considering and allows of a free flow of oil.

The half round or hog nose drill shown in Fig. 60 can be used in either the engine lathe for drilling, or in a special drilling machine designed for drilling spindles. It is commonly used, in fact, in the special drilling machines of one well-known machine tool company, for all holes under one and one-quarter inches. In its smaller sizes the hog nose drill is usually made of tool steel and the cutting end cleared and hardened the same as a lathe tool. In the larger sizes the drill is made of machine steel, and a tool steel cutting blade is fitted to the leading end. The edge of this drill is also notched to break up the chips as in the drills spoken of above. This drill, when correctly made, ground, and started, will, if well lubricated, leave as round, true, and finished a hole as any other drill.

Drilling the Hole in Spindles.

In Fig. 61 is shown an engine lathe set up for drilling the lengthwise hole in a spindle. In this case, as the spindle is rather slender and liable to spring while it is being worked upon, the tapered center

hole is made the last operation in the construction, the bearings being ground just previous. This order should always be followed for slender spindles to insure the truth of the tapered hole with relation to the bearings. The spindle is first roughed to a finishing allowance, and short bearings are turned upon the ends to a high degree of accuracy

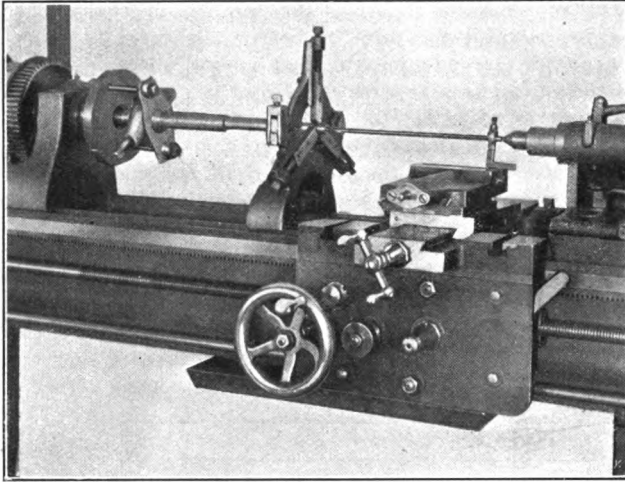

Fig. 61. Lathe Arranged for Spindle Drilling.

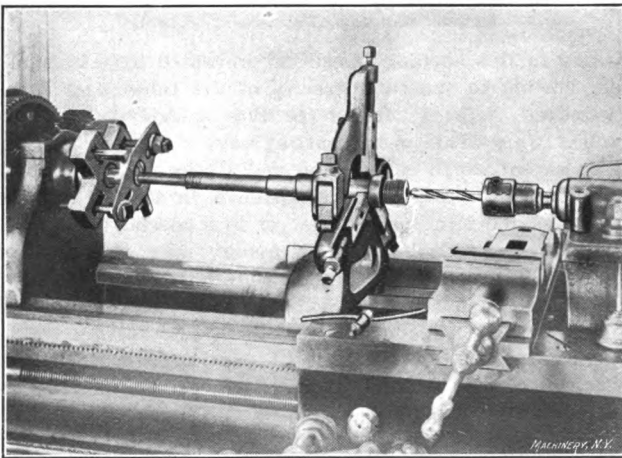

Fig. 62. Drilling for the Taper Hole.

for center rest support. The larger end or nose of the spindle is placed upon the live center, which is supposed to be trued up nicely, and is held in place on the center by a "hold back" as shown. The smaller, or what will finally be the back end, is run in a center rest, and is drilled into a short distance with a drill somewhat smaller in

diameter than the drill to be finally used. An inside boring tool held in the lathe toolpost is then used to enlarge the small hole to a size that will allow the drill it is intended to use to just slip in without shaking. The drill is in this manner started in its cut perfectly con-

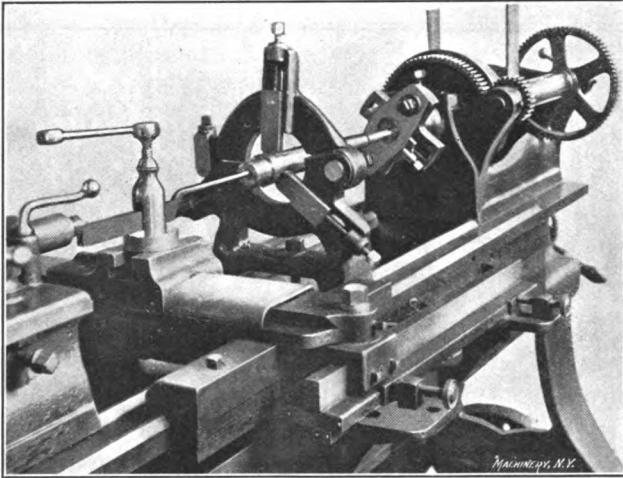

Fig. 63 Boring the Taper Hole.

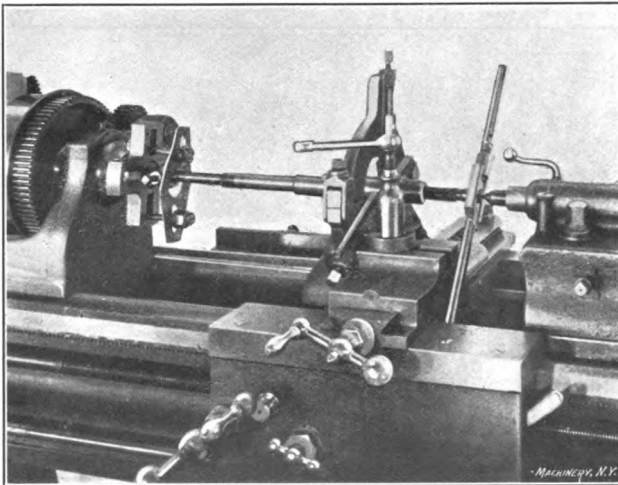

Fig. 64. Reaming the Taper Hole.

centric with the center line of the work. Drills sweated into shanks or stems of varying lengths are used to drill the hole to a depth sufficient to meet the tapered center hole when it is machined. This leaves the center hole in the face-plate end of the spindle untouched until all operations are finished. Before removing the spindle from

the center rest, the edges of the hole are chamfered to an angle of 60 degrees and to a sufficiently broad surface to form a bearing for the centers when finishing and grinding. If the spindle is stiff enough to warrant finishing the tapered center hole before grinding and finishing the spindle, it must be held with the small end trued up in

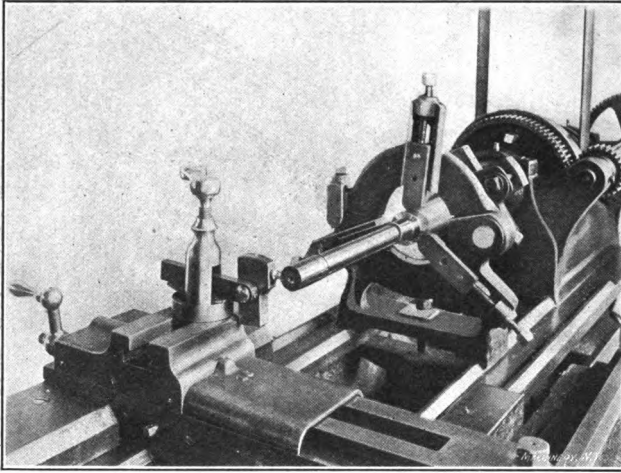

Fig. 65. Use of Test Bar and Indicator.

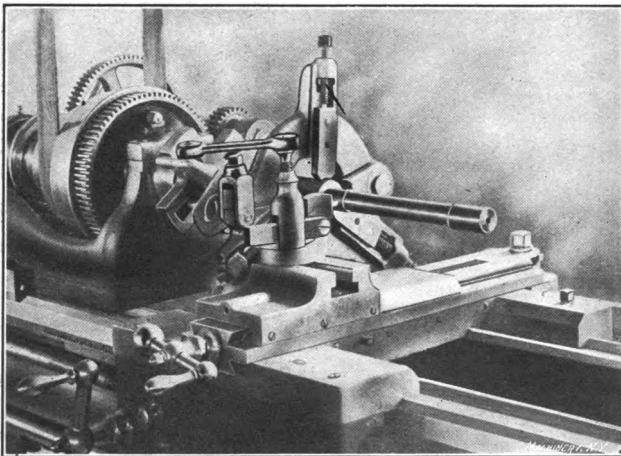

Fig. 66. Testing at the Inner End of Bar.

a chuck instead of on the live center. This brings the work in the reverse of the position shown. The nose is held in the center rest, a true-running bearing having been turned where it is to bear in the center rest. As said before, the spindle is roughed to a finishing size before drilling. The hole is then started true and is drilled as before.

If the hole is large enough, however, and the spindle stiff enough, the hole may be drilled by using some of the oil tube drills mentioned above.

Machining the Tapered Hole.

Fig. 62 shows the spindle mounted ready to have the tapered center hole machined. The drill used to rough the hole is slightly smaller in diameter than the finished hole is to be in its smallest part. After the hole is drilled, a roughing reamer like the one shown in Fig. 71 is used to fully rough out the hole. This leaves the hole of an approximate size and taper. To true the hole to perfect concentricity, it is bored out with an inside boring tool held in the lathe toolpost, as in Fig. 63. A lathe having either a compound toolpost or a taper attachment must be used for this job. The first setting of the taper will scarcely be more than an approximation, and alterations must be made after each cut until the tapered hole is like the gage used. A plug, as shown

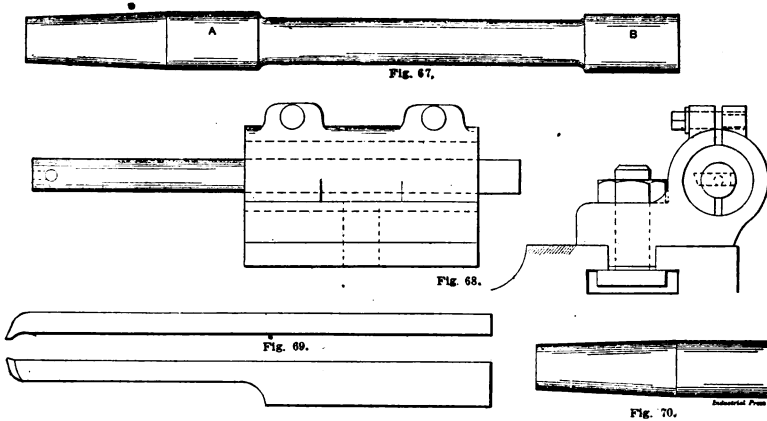

Figs. 67 to 70. Tools for Spindle Boring and Testing.

in Fig. 70, may be provided for a gage, or the finishing reamer, Fig. 72, may be used to try the taper with. Fig. 63 is a back view of the lathe and shows the taper attachment arranged to bore the tapered center hole. The hole is bored in this manner to the right diameter and finished smooth by scraping out a few thousandths with the finishing reamer held as shown in Fig. 64. If all the operations have been carefully carried out, the hole will be true when tested with the bar shown in Fig. 67. This test bar is of tool steel, hardened and ground upon the tapered surface and at the diameters A and B. Its length outside the tapered part may vary from seven inches to fifteen inches, and it must be known to be perfectly straight and round. To use this bar the tapered hole is carefully wiped out, so that no chips or oil be present. The bar is then inserted and pressed home with a slightly twisting pressure. A Bath indicator can then be held in the tool post of the lathe with its feeling point touching the test bar as in Fig. 65. The work is rotated at a medium speed and the bar is

tried at both *A* and *B*. If the error shown by the indicator is greater than the limit set for the job, a light cut with the boring tool and another light reaming may be necessary. If, however, the hole is only slightly out of true, the high side of the hole can be marked, and a light scraping with the finishing reamer upon that side will true it up. Not much stock must be removed in this way, as the result of scraping upon one side only is to make the hole oblong instead of round. When the hole has been bored and reamed very carefully, the bar will not usually run out on the first trial more than 0.001 inch in 10 inches, and a touch of scraping will put this error right. The inside boring

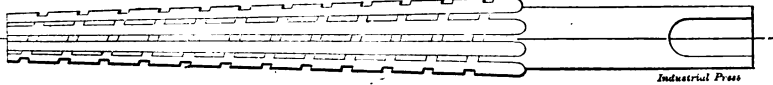

Fig. 71. Roughing Taper Reamer.

tool shown held in the toolpost in Fig. 63 is the common forged tool, and its usual form is shown in Fig. 69. Where shallow holes are to be turned out this is a good tool and is cheaply made. The tool and holder shown in Fig. 68 is, however, a better form when much work is to be done. The bar that holds the tool can be revolved to bring the tool point into any desired relation to the hole. By the use of suitable bushings, bars of any diameter may be used, and the length of bar can be easily suited to the length of the hole it is to be used upon. This holder takes several shapes or forms in different shops, and is well worth its cost. When large holes are to be started in the

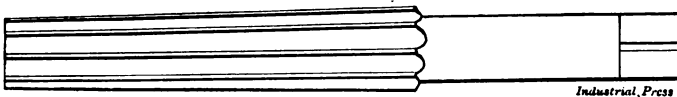

Fig. 72.

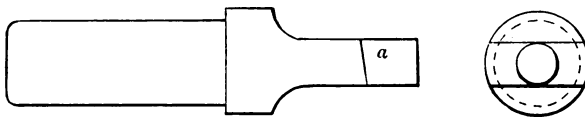

Fig. 73.

Figs. 72 and 73. Finishing Reamer and Counter-bore.

end of the spindle, a small drill may be used to drill a shallow hole. The shallow hole can then be turned concentric with an inside boring tool, as stated above, and finally enlarged to the diameter of the drill to be used by counterboring with the tool shown in Fig. 73. The teat or leader *a* is a nice fit in the smaller concentric hole, and leads the cutting edges straight with the center line. A depth sufficient to admit the sizing drill beyond its cutting edges is all that needs to be made with the counterbore.

Taper reamers have a tendency to draw into the work when in use. To counteract the drawing-in action, it is common practice to cut a

left-hand helix upon the reamer. Finishing reamers are, however, seldom treated in this manner, as their use is just to scrape the hole to a perfect surface.

It may be mentioned here that there are several errors that one is apt to make in finishing a tapered hole in a spindle. 1. If the spindle is slender, care must be taken that the hold-back or clamp does not spring the work by being tightened up too hard. Anything more than enough to hold the work to the center is too much. 2. In turning out the hole with the boring tool, set the cutting point at the height of the center line of the lathe spindle to get a true tapered hole. 3. Be sure that the

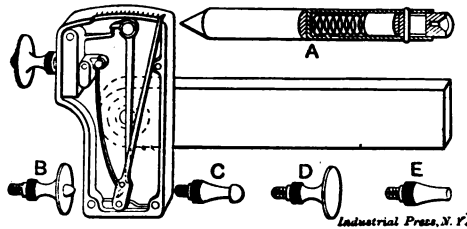

Fig. 74. Bath Test Indicator.

center line of the work and the live and dead centers are coincident with the center line of the spindle. Fig. 74 shows the interior of the Bath indicator and the several feeling points used. This is a very sensitive tool. A movement of 1-2000th inch of the feeling point moves the indicator finger a distance of 1-12th inch.

Boring Crucible Steel Forging Spindles.

Crucible steel forgings for lathe spindles, as delivered to the workman, are usually somewhat crooked and may be enough so as to require straightening, but there is usually an excess of stock to finish, and if the centers are located with judgment, the forging will finish

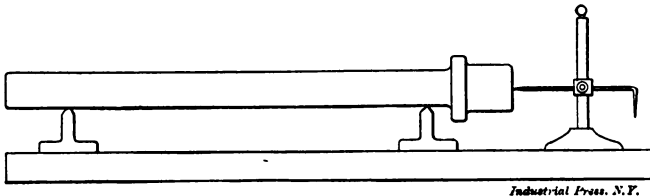

Fig. 75. Simple Method for Locating Centers.

out. Various ways of locating the centers are in use in different shops. The cut, Fig. 75, illustrates the method in use in one shop. Two "ways," similar to those used in balancing pulleys, are provided, and the forging is laid across these. Care must be exercised to have the "ways" placed so that the center of what is to be the journal bearing is central with them. The journals are, of course, the most important parts of the spindle and must clean out when to size. The forging is rolled into several positions on the "ways," and is scribed across each end with a scratch block or a surface gage, and the center

located with a center punch. The center drilling and reaming is afterwards done under a drill press, and the forging is ready for the reduction lathe. With high-speed steel tools the forgings are roughed to approximate sizes and shapes at a rapid rate. A feed of $1/16$ inch per revolution is a common standard, with a depth of cut

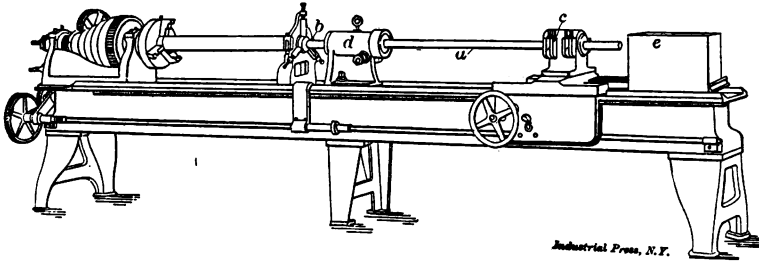

Fig. 76. Spindle Boring Lathe.

of $1/8$ -inch and a surface speed of one hundred and twenty-five to two hundred feet per minute. While coarser feeds and depths of cut are possible, it is not usual to push the tool much beyond those given, on work of this size.

From the reduction lathe, where the roughing is done, the spindle goes to the special spindle drilling lathe illustrated in Figs. 76, 77,

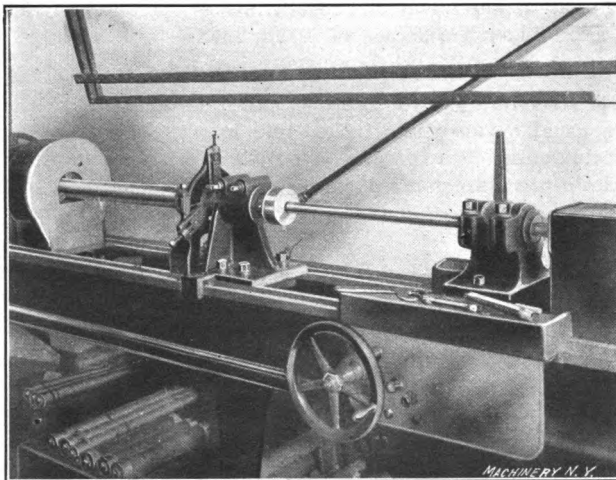

Fig. 77. Drilling the Hole through the Spindle.

and in section in Fig. 82, in which latter cut the drill appears in connection with its extension tube. In Fig. 84, c, is shown a drill with straight flutes and in Fig. 83 one with spiral flutes. Either of these drills may be used as tools in the drilling lathe shown.

In Fig. 76, *a* is the tubular extension of the drill *b*. The tool clamp *c* is held upon an ordinary lathe carriage and is fed to the work in the

same manner as a lathe tool in regular turning operations; d is a center rest or guide and serves two purposes. It centers the drill and steadies it to its work, and it also furnishes a reservoir through which oil is pumped to the drill as it cuts its way through the blank. As shown in Figs. 76 and 78, d is drawn back from the drilling position to

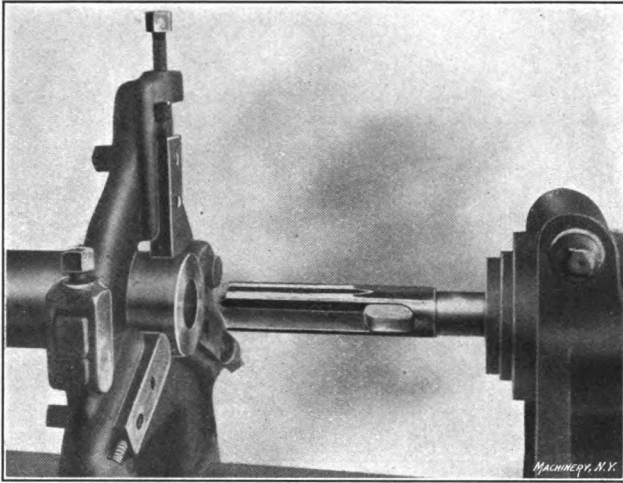

Fig. 78. Showing the Guide Drawn Back to Expose the Drill.

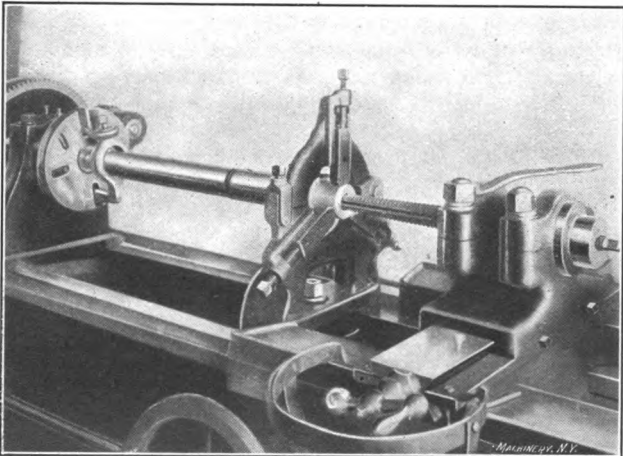

Fig. 79. Roughing Out the Tapered Hole.

show the drill more clearly. In use it is close to the end of the spindle or embraces the end as shown in Figs. 77 and 82. The tank e is attached to the carriage by a hook and is towed by it. The oil and chips fall into this tank as they are forced through the tube a by the pump pressure. The front end of the tank is made of wire netting.

and this allows the oil to drain to the lathe bed, the chips being held back by the netting. The lathe bed is fitted with a bottom for holding oil, and is furnished with a pump to force the oil to the cutting edges of the drill.

By comparing Fig. 83 and Fig. 84, c, it will be seen that the oil

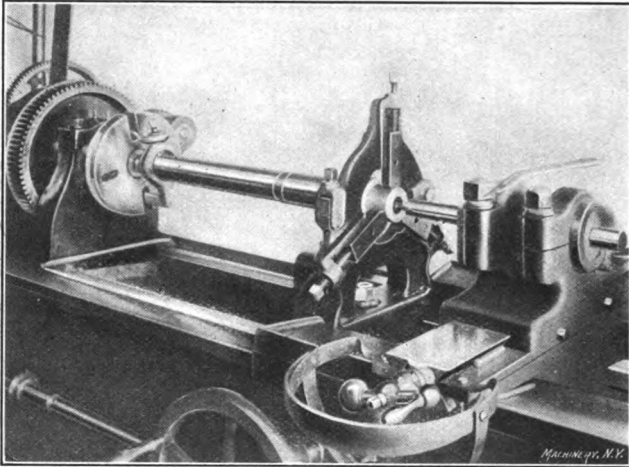

Fig. 80. Truing the Hole in the End of the Spindle with Boring Tool.

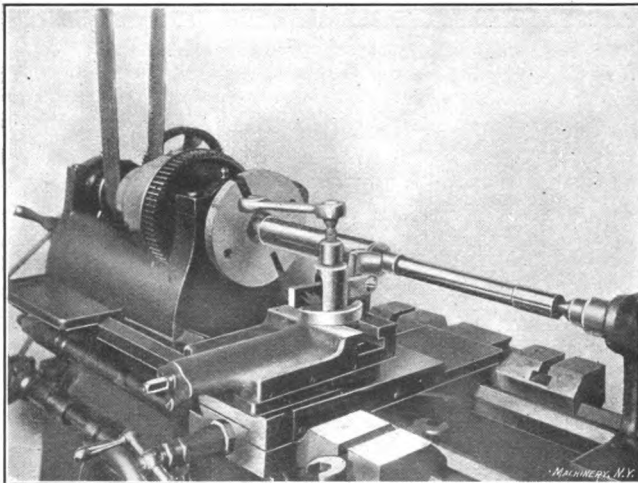

Fig. 81. Accurate Method of Testing Hole in Spindle.

from the pump strikes the outside of the drill at the rear end of the flutes and is forced along the flat channels on the outer surface until it reaches the cutting end of the drill. The oil then returns by the deep grooves to the hole, where the grooves meet, and thus enters the tube *a*, passing to the tank *e*, taking along at the same time the chips

as they are cut from the stock. To ensure a free flow of oil past the cleared end of the drill, the backing at the end of the flute must be ground sharply away, as previously mentioned. Small grooves are ground or milled along the cutting lips to break the chips to a size that can be made to force out with the oil. While Fig. 76 and Fig. 82 show details of the several parts, Fig. 77 is from a photograph of a spindle drilling lathe in actual use.

Finishing the Spindle.

When the drilling is completed, several methods of finishing the spindle are in vogue, and some of these methods may be of interest.

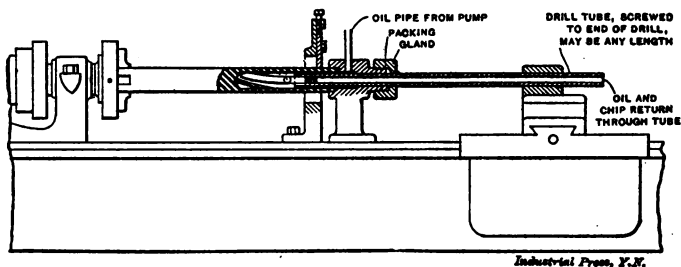

Fig. 82. Section of Drill Showing Means for Oil Circulation.

When the hole through the spindle is completed, the spindle should be laid aside for a time, so that all the strains may be relieved. If it is desired that the tapered or center hole be finished before the spindle is ground to dimensions, a hardened and ground plug with a true running center is driven into the rear of the spindle, and it is then mounted in a center rest as shown in Fig. 79. The roughing reamer is shown in position to begin roughing the hole to an approximate size and taper. The holder for the roughing reamer is a sleeve with the back end tapped to take an adjustable threaded center. The shank of the roughing reamer is made to fit loosely in the cylindrical holder and is kept



Fig. 83. Drill with Channels for Oil.

from turning by a pin through the holder and the reamer shank. The rear center hole of the reamer is held upon the threaded center, and the reamer is as free to adjust itself as possible, the pin preventing its slipping off the center, and also preventing it from turning. The hole is afterward bored to perfect concentricity by using an inside boring tool held as in Fig. 80. To finish the hole, a tapered finishing reamer is held rigidly in the tool block and is used to scrape the hole smooth. As little stock as possible is removed by this last operation. The plug in the rear end of the hole is next driven out, and the rear end of the spindle is countersunk by using the tool shown at *d*, Fig. 84. This

tool is a combined countersink and pilot and is furnished with sleeves that fit nicely into the longitudinal hole.

The test bar shown in Fig. 67 is placed in the tapered hole and the spindle and bar are held on centers in a lathe as in Fig. 81. If now it is found that the test bar shows eccentricity at the front end of the spindle, the rear reamed center is scraped until the test bar re-

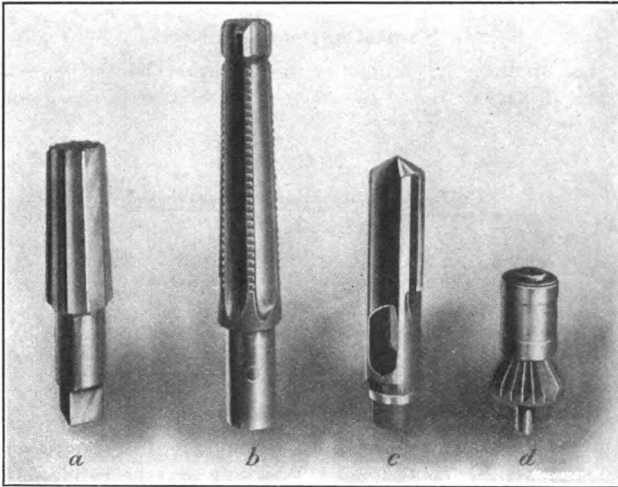

Fig. 84. Tools used in Machining the Spindle Hole.

volves true when tested with the "indicator." When this is attained it is sure that the center reaming in the rear end is true with the finished tapered hole, and when a true running plug is centered in the tapered hole the spindle is in readiness to be threaded, keyseated, and ground to fit the several gears, pulleys, bearings, etc., that are placed on it. If after these operations are completed the spindle does not test up true, there has been carelessness in some of the operations.

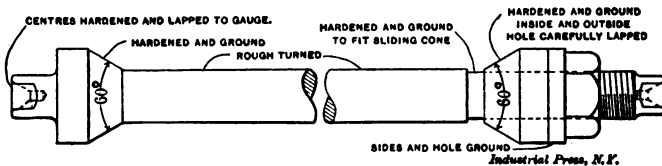

Fig. 85. Arbor used when Grinding Spindle

When the face gear next to the front bearing is keyed into place, it is necessary to countersink it lightly, and then stake down the shoulder on the spindle hard enough to prevent the gear slipping along the spindle when the lathe center is driven out. While staking this gear on, frequent tests should be made to see that the spindle is not thrown out of truth. The method of finishing that follows is another good way of completing the spindle.

After the long hole is drilled, the edges of the hole at each end are chamfered to a 60 degree bearing, using as before the special countersink shown in Fig. 84, *d*, and the spindle is turned to leave 0.007 of an inch on all diameters for grinding, and all keyways and threads are cut except the thread on the nose of the spindle. An arbor such as the one shown in Fig. 85 is then passed through the spindle and tightened into place by the nut shown. This arbor being a standard upon which many pieces may be ground, no pains should be spared to make sure that all surfaces are square and true with the center line. All the grinding is done with the spindle mounted upon this arbor, and as the centers in the arbor are lapped to as near perfection as possible, and are so hard that the wear is small, this method would seem to give very perfectly ground surfaces. The tapered hole is finally finished by holding the spindle upon the live center and in a center rest, as formerly described. The truth of the tapered hole can be tested with the "Bath" indicator as in Fig. 65, or the indicator point may be used against the inside of the tapered hole if it is de-

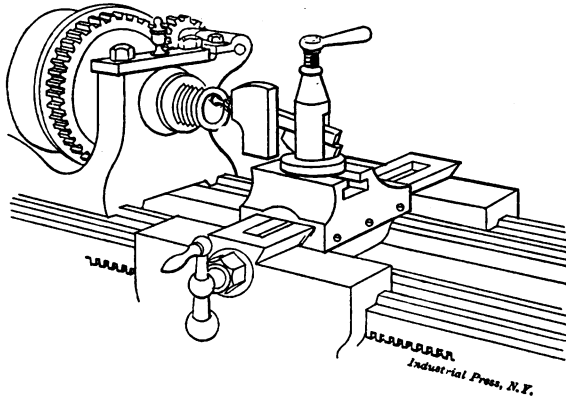

Fig. 86. Method of Testing Taper Hole.

sired. This latter method of testing is shown in Fig. 86, but the one shown in Fig. 65 is to be preferred if the greatest accuracy is desired.

Still another method is to rough-ream the center hole, and then grind the several bearings upon plugs driven into the ends of the spindle. When the gears and the cone pulley are in place, the spindle is scraped and fitted into its bearings. After this is done the headstock is mounted on the bed of the machine, and the tapered center hole is bored out true with a tool held in the tool block, and then reamed lightly and tested as before until it is true running within the limit of error set. This method is a very good one if the spindle has not changed after it was ground. It is quite likely, however, that some changes have taken place when the gears were keyed on, and the spindle is out of true. If the center hole is then bored with the spindle in its bearings the center hole is true with an imperfect and twisted spindle. Using the lathe tends to relieve the strains put into

the spindle by keying and staking on the gears, and it assumes its original truth as ground. This throws the tapered center hole out of line with the lathe, and results in a poor running live center and one that can only by accident be replaced and run true. By the first two methods for finishing the center hole and the surface of the spindle true with each other, any changes made when setting up can be detected and remedied at the time of their occurrence.

The spindles made by the above described methods are usually of sixty point carbon and are unhardened. If greater wearing qualities are desired in the spindle bearings than such spindles will give, low carbon steel is often used for the spindle, and the bearings are then casehardened. The casehardening is done just before the grinding and fitting and is from 1/32 inch to 1/16 inch deep, and only on the surfaces used for the bearings. To accomplish this, the parts it is desired to retain soft are copper-plated before treating the surfaces it is desired to harden. This copper-plating prevents the action of the casehardening compound upon these surfaces, and the unplated surfaces only are hardened.

In grinding spindles with a long keyway in the surface, as for instance a drill press spindle, it is usual to fit a strip of hard wood into the keyway, and then shape the wood to the circumference of the spindle. When grinding spindles it is desirable to have two grinding machines so set as to have the workman between the two. One machine will have a coarser wheel mounted and will bring the spindles to within 0.001 of an inch of size; they can then be finished upon the second machine with a finer wheel, leaving a surface that does not need polishing. A feed of from one-quarter to three-eighths inch per revolution should be maintained when grinding, and the spindle should be amply supported by back rests.

