

ANIMAL AND VEGETABLE
FIXED OILS, FATS, BUTTERS,
AND WAXES.

ANIMAL AND VEGETABLE
FIXED OILS, FATS, BUTTERS,
AND WAXES:

THEIR PREPARATION AND PROPERTIES,

AND THE

Manufacture therefrom of Candles, Soaps, and
other Products.

BY

C. Knoll
C. R. ALDER WRIGHT,

D.Sc. (LOND.), B.Sc. (VICT), F.R.S.,

LECTURER ON CHEMISTRY IN ST. MARY'S HOSPITAL MEDICAL SCHOOL, LONDON; EXAMINER IN
"SOAP" TO THE CITY AND GUILDS OF LONDON INSTITUTE.

With 144 Illustrations.

LONDON:
CHARLES GRIFFIN & COMPANY, LIMITED;
EXETER STREET, STRAND.

1894.

[All Rights Reserved.]

P R E F A C E .

The complete discussion of the Sources, Production, and General Technology of the numerous substances included in the term *Oils*, and of the intimately associated *Fats*, *Butters*, and *Waxes* (all of which are practically oils when melted), would require far more space than is compatible with the limits of the present work; it has accordingly been found indispensable to make a selection from this wide field, as the result of which the subjects now dealt with are narrowed down to the Animal and Vegetable Fixed Oils and allied substances; whilst Mineral Oils, Products of Distillation, Essential Oils, and various analogous materials are only discussed in so far as they are associated with the Fixed Oils in their technological applications. For the same sufficient reason minute details respecting the various special tests employed in the practical examination of oils, &c., for adulterations have, as a rule, been omitted; as also have the descriptions of the distinctive properties and qualities of the individual oils and fats, excepting in a comparatively small number of typical cases. In short, the object aimed at has rather been to give general descriptions of the methods whereby Animal and Vegetable Oils and Fat are obtained from natural sources, of their leading practical applications and uses, and of their chief physical and chemical properties and reactions, than to enter into special details, and to discuss minutely the analytical tests and processes applicable in each separate case for the detection of adulteration.

The literature relating to the chemistry and technology of fixed oils and fats is already voluminous, and yearly increases considerably in magnitude, being mostly dispersed throughout the pages of numerous scientific and technical serials. Amongst the periodicals of this description consulted for the purpose of gathering together to some extent these scattered results and items may be more particularly mentioned:—

The Journal of the Society of Chemical Industry.

The Journal of the Society of Arts.

The Journal of the Chemical Society.

The Analyst.

The Chemical News.

Zeitschrift für angewandte Chemie.

Berichte der Deutschen Chemischen Gesellschaft.

Dingler's Polytechnisches Journal.

Biedermann's Technisch-Chemisches Jahrbuch.

Moniteur Scientifique.

Bulletin de la Société Chimique de Paris.

Comptes rendus.

Besides many others in which papers bearing on the matters in hand appear from time to time. Various text-books and technical dictionaries previously published in this country or abroad have also been freely consulted with the object of rendering the present work as complete as possible, with due regard to the limits of space. In particular the author desires to express his indebtedness to the following works:—

Schädler, *Technologie der Fette und Oele*.* Berlin, 1883.

Allen, *Commercial Organic Analysis*, vol. ii., Second edition. London, 1886.

Schädler, *Untersuchungen der Fette und Oele*.* Leipzig, 1889.

Benedikt, *Analyse der Fette und Wachsarten*, Second edition. Berlin, 1892.

* Whilst the present book was in the press the two works by Schädler above mentioned have been incorporated into a single volume, edited by P. Lohmann after the decease of the original author.

To the firm of Rose, Downs, & Thompson, of Hull, the author is greatly indebted for numerous illustrations of the most recent and effective forms of oil mill machinery, as well as for valuable information concerning their use in oil extraction generally. In similar fashion he desires to thank Messrs. Neill & Sons, of St. Helens, for a variety of specially made drawings of appliances used in soap manufacture; Messrs. S. H. Johnson, of Stratford, for drawings of the newest forms of filter presses; and Messrs. E. Cowles & Co., of Hounslow, for cuts of improved candlemaking machines.

C. R. ALDER WRIGHT.

LONDON, *October*, 1893.

TABLE OF CONTENTS.

§ 1. General Composition and Nature of Oils, Butters, Fats, Waxes, and Allied Substances.

	PAGE		PAGE
CHAPTER I.			
THE SOURCES AND GENERAL NATURE OF NATURAL AND ARTIFICIAL OILS.		Glycerol, Glycerides, Hydrolysis of Glycerides,	7
Meaning of the Terms "Oil," "Fat," "Butter," and "Wax,"	1	Fatty Alcohols, Ethylic Series, &c.,	13
Sources and General Nature of Oils,	2	Glycols,	18
Nature of Saponification Changes,	3	CHAPTER III.	
Classification of Oils, Fats, Waxes, &c., according to Chemical Composition,	5	ACID SAPONIFICATION PRODUCTS OF OILS, FATS, WAXES, &C.	
CHAPTER II.		<i>Fatty Acids</i> —Acetic Family,	18
ALCOHOLIFORM SAPONIFICATION PRODUCTS OF OILS, FATS, WAXES, &C.		Oleic Family,	24
		Linolic Family,	30
		Linolenic Family,	36
		Glycollic Family,	37
		Ricinoleic Family,	39
		Oxystearic Acids,	43

§ 2. Physical Properties of Oils, Fats, Waxes, &c.

CHAPTER IV.		Determination of Specific Gravity,	77
GENERAL PHYSICAL CHARACTERS.		Construction of Tables of Errors for Hydrometers and Hydrostatic Balances,	82
Physical Texture and Consistency; Cohesion Figures,	47	Hydrometer Scales,	84
Taste, Odour, and Colour,	49	Relative Densities of the Principal Oils, Fats, &c.,	86
Action of Polarised Light; Refractive Index,	50	Classification of Oils, Fats, &c., according to their Relative Densities,	89
Solubility of Oils, Fats, &c., in various Solvents,	53	Variation of Density of Oils, &c., with Temperature,	92
Thermometric Scales,	57	Viscosimetry; Mechanical Testing Arrangements,	94
Methods used in the Determination of Fusing and Solidifying Points,	60	Efflux Viscosimeters,	95
Freezing and Melting Points of Oils, &c.,	68	Standards of Efflux Viscosity,	101
CHAPTER V.		Relative Viscosity of Oils, &c.,	102
SPECIFIC GRAVITY AND VISCOSITY.		Determination of Viscosity in Absolute Measure,	107

§ 3. Chemical Properties of Oils, Fats, Butters, and Waxes.

	PAGE		PAGE
CHAPTER VI.			
PROXIMATE CONSTITUENTS AND THE METHODS USED FOR THEIR EXAMINATION AND DETERMINATION.		Action of Sulphuric Acid on Oils and Fats; Turkey Red Oils, . . .	143
Compound Nature of Oils, Fats, and Waxes; Variations in Composition with Circumstances of Natural Formation, . . .	110	Maumené's Sulphuric Acid Thermal Test, . . .	147
Methods Employed for Separating Constituents, . . .	112	Various Colour Reactions, . . .	151
Determination of Free Fatty Acids; Free Acid Number, . . .	116	Sulphur Chloride Reaction; Vulcanised Oils, . . .	154
Determination of Unsaponifiable Constituents, . . .	119	CHAPTER VIII.	
Determination of Water, . . .	122	QUANTITATIVE REACTIONS OF OILS.	
Adulteration of Fats with suspended Matters, . . .	123	Kœttstorfer's Test—Total Acid Number, . . .	157
Sulphurised and Phosphorised Constituents, . . .	123	Classification of Oils, &c., according to their Saponification Equivalents, . . .	159
CHAPTER VII.			
CHEMICAL REACTIONS OF OILS, FATS, &C., AND THEIR USES AS TESTS OF PURITY, &C.		Practical Determination of Saponification Equivalents of Glycerides, &c., . . .	159
Effect of Heat on Oils, &c.; Flashing Point, . . .	125	Proportion of Fatty Acids formed by Saponification, . . .	163
Characteristic Oxidation Products, . . .	128	Helmer's Test; Insoluble Acid Number, . . .	166
Spontaneous Oxidation of Oils, Fats, &c.; Effect of Light thereon, . . .	129	Practical Determination of the amount of Fatty Acids formed on Saponification, . . .	167
Spontaneous Combustion, . . .	132	Corrections for Anhydro Derivatives, Free Acids, and Unsaponifiable Matters, . . .	170
Film Test; Livache's Test, . . .	133	Mean Equivalent of Fatty Acids contained in Soap, . . .	172
Chemical Changes occurring during drying of Oils, . . .	134	Reichert's Test and Modifications thereof, . . .	173
Elaidin Reaction; Legler's Consistency Tester, . . .	137	Bromine and Iodine Absorption; Bromine Process, . . .	176
Nitric Acid Test, . . .	139	Iodine Process; Hübl's Test, . . .	179
Zinc Chloride Reaction and Colour Test; Action of Zinc Chloride on Oleic Acid, . . .	141	Iodine Numbers of Oils, Fats, &c., . . .	180
		Acetylation Test; Benedikt and Ulzer's Test, . . .	186
		Methyl Iodide Test; Zeisel's Test, . . .	191
		Tabulated results of the various Quantitative Tests, . . .	194

§ 4. Processes Used for Extracting, Rendering, Refining, and Bleaching Oils, Fats, &c.

CHAPTER IX.			
EXTRACTION OF OILS FROM SEEDS, &C., BY PRESSURE OR SOLVENTS.		Elbow, Wedge, and Screw Presses, . . .	202
Earlier forms of Press, . . .	199	Hydraulic Press, . . .	207
		Composition of Oilcake, . . .	213
		Oil Mill Plant; "Unit" Mill, . . .	214

PAGE	PAGE
Crushing Rolls and Edge	under ordinary Atmospheric
Runners, 218	Pressure, 247
Kettle; Moulding Machine, 221	Rendering under Increased
Paring Machine; Supplementary	Pressure, 250
Appliances, 223	Extraction of Fat from Bones, 251
Decortication, 224	
Filter Presses, 226	CHAPTER XI.
Separation of Solid Stearines from	REFINING AND BLEACHING ANIMAL
Oils, &c., 229	AND VEGETABLE OILS, FATS,
Manufacture of Lard Oil, and	WAXES, &c.
Allied Products, 231	Suspended Matters, 254
Extraction of Oil from Seeds, Oil-	Dissolved Matters, 256
cake, &c., by Solvents, 231	Sulphuric Acid Process for
Extraction of Grease from Engine	Refining Oils, &c., 259
Waste, &c., 236	Alkaline Refining Processes, 260
Determination of Fat in Seeds,	Utilisation of "Foots," 261
&c., 237	Clarification, 262
Proportion of Fatty Matter Con-	Bleaching Oils and Fats, 263
tained in Seeds, &c., 241	Wax Bleaching, 268
	CHAPTER XII.
CHAPTER X.	RECOVERY OF GREASE FROM
ANIMAL FATTY TISSUES: EXTRACT-	"SUDS," &c.
ION OF OILS AND FATS	Modes of Treating Soap Suds, 270
THEREFROM.	Analysis of Yorkshire Grease, 273
Rendering of Fatty Tissues by	Distilled Grease, 277
Dry Fusion, 246	Engine Waste Grease, 279
Rendering of Fatty Tissues by	
Heating with Water or Steam	

§ 5. Classification and Uses of Fixed Oils, Fats, Waxes, &c.; Adulterations.

CHAPTER XIII.	,, VIII. Vegetable Butters,
CLASSIFICATION.	Fats, Waxes, &c., 295
Classification according to Text-	Lesser Known Vege-
ure, Sources, and Essential	table Butters, &c., 296
Chemical Nature. 281	,, IX. Animal Fats—Tallow,
CLASS I. Olive (Almond) Class;	Lard, and Butter Class, 298
Vegetable Expression	,, X. Animal Oils — Sperm
Oleines, 282	Oil Class, 299
,, II. Rape (Colza) Class, 284	,, XI. Vegetable Nonglyce-
,, III. Castor Class, 284	ridic Waxes, 301
,, IV. Animal Non-Drying	,, XII. Beeswax and Sperma-
Oils—Lard Oil Class, 285	ceti Class, 301
,, V. Sesamé or Cotton Seed	CHAPTER XIV.
Class — Vegetable	PRINCIPAL USES OF OILS AND
Semidrying Oils, 286	FATS, &c.
Lesser Known Vege-	Classification according to Uses, 302
table Oils, 287	Edible and Culinary Uses of Oils,
,, VI. Drying Oils — Linseed	Fats, &c., 303
Oil Class, 290	Cotton Seed Stearine; Vegetable
,, VII. Train, Liver, and Fish	Lards, 305
Oils, 292	

	PAGE		PAGE
Manufacture of Hog's Lard,	306	CHAPTER XV.	
Manufacture of Artificial Lard and Butter,	305	ADULTERATION OF OILS AND FATS.	
Utilisation of Fatty Matter from an Ox,	311	Methods employed in Detecting Adulterations,	340
Lamp Oils,	312	Relative Values of Oils,	342
Drying Oils used in making Paints and Varnishes,	313	General Characters of Olive Oil and Tests for Adul- terations thereof,	342
Blown Oils- Oxygen Process,	319	„ Rape Seed and Colza Oil,	348
Miscellaneous Uses of Oils, Fats, &c.; Manufacture of Lubri- cants,	321	„ Linseed Oil,	349
Analysis of Lubricating Oils and Greases,	323	„ Sperm Oil,	353
Turkey Red Oils; Analysis,	330	„ Tallow,	354
Carrier's Grease, Sol Oils, and Dégram,	336	„ Beeswax,	357
Manufacture of Lanolin,	337	„ Spermaceti,	359

§ 6. The Candle Industry.

CHAPTER XVI.			
MATERIALS USED IN CANDLE- MAKING.			
Origin of Candles; Combustible Materials,	362	Hydrolysis of Glycerides by Water only,	385
Manufacture of "Stearine;" the Chevreul-Milly Process,	364	Utilisation of Red Oils,	386
Composition and Analysis of "Rock,"	371	CHAPTER XVII.	
Milly-Autoclave Process,	373	MANUFACTURE OF CANDLES, TAPERS, AND NIGHT LIGHTS.	
Analysis of Red Oils, Separation Cake, and Similar Products,	378	Basted and Drawn Wax Candles, Tapers, &c.,	388
Sulphuric Acid Process,	380	Dip Candles; Dipping Machinery, Wicks; Wick Pickling,	390 394
		Moulded Candles; Handmade, Continuous Moulding Machines, Night Lights and Medicated Candles,	395 398 406

§ 7. The Soap Industry.

CHAPTER XVIII.		CHAPTER XIX.	
MATERIALS USED IN THE MANU- FACTURE OF SOAP.		SOAPMAKING PLANT.	
Fatty Matters; Alkalies,	408	Heating Appliances; Free-fired Soap Coppers,	426
Causticising Process,	411	Morfit's Steam Twirl,	429
Valuation of Alkalinity of Leys,	414	Steam-heated Soap Coppers, Curb and Fan,	432 433
Corrections for Impurities,	419	Soap Pumps,	434
English, French, and German Degrees,	420	Soap Frames,	434
Calculations,	421	Barring and Slabbing,	437
Formule,	425	Crutching,	438

PAGE	PAGE
Toilet Soap Machinery; Remelt- ing,	441
Stamping,	444
Transparent Soaps,	445
Milling,	446
Plotting,	448
CHAPTER XX.	
MANUFACTURE OF SOAP.	
Soapmaking Processes; Direct Neutralisation,	449
Calculations,	454
Processes in which the Free Gly- cerol is retained; Cold Process Soaps,	456
Soft, Hydrated, and Marine Soaps,	459
Calculations,	464
Processes in which the Glycerol is separated; Curd Soaps,	466
Graining,	469
Fitted and Mottled Soaps,	470
Special Varieties of Soap; Rosin Soaps, Silicated Soaps, &c.,	473
Toilet and Fancy Soaps; Milled Soaps,	478
Transparent Soaps, &c.,	481
Neutralised Soaps,	483
CHAPTER XXI.	
GENERAL CHEMISTRY OF SOAP— SOAP ANALYSIS.	
General Properties of Soaps; Hydrolysis of Soap Solutions,	484
Reaction of Soap Solution or of Fused Soap on Inorganic and other Salts,	488
Methods Used in the Analysis of Soap,	492
General Scheme for Analysis,	506
Composition of Manufacturers', Laundry, and Toilet Soaps, &c.,	508
Classification of Toilet Soaps according to amount of Free Alkali present,	512
CHAPTER XXII.	
GLYCEROL EXTRACTION—MANU- FACTURE OF GLYCERINE.	
Sources of Glycerol; Extraction,	513
Valuation of Commercial Glycer- ine; Estimation of Glycerol in Watery Solution,	516
Glycerol in Soap Leys,	522
INDEX,	525

LIST OF ILLUSTRATIONS.

FIG.	PAGE
1. Cohesion Figures,	48
2. Capillary Tubes used for determining Fusing Points,	60
3. Mode of attachment to Thermometer,	61
4. Mode of heating the arrangement in Water,	61
5. Another Mode,	62
6. Olberg's Water Bath,	62
7. Bensemann's Tubes,	63
8. Pohl's Method,	64
9. Cross and Bevan's Method,	63
10. Læwe's Method,	65
11. Mohr's Hydrostatic Balance,	78
12. Westphal's do.,	79
13. Lefebvre's Oleometer,	80
14. Hot Air Bath for use with Westphal's Hydrostatic Balance,	81
15. Ambuhl's Arrangement,	81
16. Schübler's Viscosimeter (Efflux Method),	95
17. Schmid's do.,	96
18. Redwood's do.,	97
19. Do. do.,	98
20. Allen's Modification of Viscosimeter,	98
21. Engler's Viscosimeter,	99
22. Hurst's do.,	100
23. Redwood's Chart of Viscosity of Oils,	103
24. Do. do. do.,	104
25. Lepenau's Leptometer,	107
26. Traube's Apparatus,	109
27. Chattaway's Tubes,	120
28. Abel's Flashing Point Apparatus,	126
29. Pensky's Modification of same,	127
30. Legler's Consistency Tester,	139
31. Apparatus for Maumené's Test,	147
32. Jean's Thermeleometer,	151
33. Benedikt and Grüssner's Apparatus for Zeisel's Test,	193
34. Elbow Press,	202
35. Wedge Press, Front Elevation,	203
36. Do. Side do.,	203
37. Do. Longitudinal Section,	204
38. Screw Press (English),	205
39. Do. (German),	206
40. Hydraulic Press (German, empty),	208
41. Do. (after the ram has risen),	209
42. Do. (English, Handworked),	210
43. Do. (Anglo-American System),	211

FIG	PAGE
44. Hydraulic Press, Plan and Longitudinal Section of Plate,	212
45. Do. Cross Section of Plate,	212
46. Oil Mill Plant; Ground Plan of 16-press Installation,	216
47. Crushing Rolls,	218
48. Edge Runners,	219
49. Kettle,	220
50, 51. Envelopes,	221
52. Paring Machine,	222
53. Decortication of Cotton Seeds,	224
54. „ of Castor Beans,	224
55. Disintegrator and Elevator,	225
56. Filter Press,	226
57. Do., Front Elevation of Plates,	226
58. Do., Sectional do.,	226
59. Do., with Pyramid Drainage Surfaces,	227
60. Do., do. do.,	228
61. Do., Small Handworked,	229
62. Apparatus for Oil Extraction by Solvents,	233
63. Heyl's Distillation Apparatus,	234
64. Deitz's Extraction Apparatus,	235
65. Plant for Cleansing Engine Waste,	237
66, 67. Soxhlet's Tube (two forms),	238
68. Allihn's Reflux Condenser,	239
69. Frühling's form of Soxhlet Tube,	239
70. Reservoir for same,	240
71. Laboratory Extraction Apparatus,	240
72. Honig and Spitz's Apparatus,	240
73. Wilson's Digester,	250
74. Barrel Digester for Extracting Fat from Bones,	252
75. Leuner's Apparatus,	253
76. Free-fired Pan for Boiling Oil,	316
77. Steam-heated Oil Kettles,	317
78. Open Pan used in manufacturing Stearine,	366
79, 80. Crystallising Pans,	367
81. Hot Press,	368
82. Plant for Saponification by Open Pan Process,	369
83. Plant for Hydrolysis of Fats by means of Sulphuric Acid,	381
84. Knab's Apparatus for Distillation by Superheated Steam,	382
85. Plant for Hydrolysis of Glycerides by Superheated Steam,	386
86. Basting Wheel,	388
87. Drawing Tapers,	389
88. Knife for Cutting off Butt Ends,	390
89. Rotating Candle Dipper,	390
90. Edinburgh Wheel,	391
91. Wick-holder,	392
92, 93. Dipper with Movable Cauldron,	393

FIG.	PAGE
94. Candle Mould,	396
95. Hand Moulding Frame,	396
96. Mode of fixing Wick,	396
97, 98. Improved Moulding Frame,	396
99. Royan's Continuous Wick Moulding Machine,	397
100. Camp's Moulding Wheel,	398
101. Piston of Moulding Machine,	399
102. Moulding Machine and Nippers,	400
103. Self-fitting Butt End,	402
104. Machine for Moulding Self-fitting Butt End Candles,	403
105. Turnover Machine,	404
106. Polishing Machine,	405
107. Soap Tank for holding Ley,	412
108. Free-fired Soap Pan,	427
109. Another form of do.,	427
110. Steam-heated Pan,	428
111. Morfit's Steam Twirl,	429
112. Soap Copper,	430
113. Morfit's Steam Series,	430
114. Modern form of Steam-heated Pan,	431
115. Plan of same,	432
116. Fan,	434
117. Rotary Soap Pump,	434
118. Mode of building up Wooden Frames,	435
119. Galvanised Iron Frames,	435
120. Improved form of Steel Soap Frame,	436
121. Cutting Soap,	437
122. Looped Wire used for cutting,	437
123. Scribe,	438
124. Slabbing and Barring Machine,	439
125. Padded Frame,	440
126. Hand Crutch,	440
127. Crutching Machine,	440
128. Jacketted Crutching Machine,	440
129, 130. Series of Crutching Pans,	442
131, 132. Neill and Son's Remelter,	443
133. Hand Tablet Stamping Machine,	444
134, 135. Steam Stamping Machine,	445
136. Rutschmann's Stripping Machine,	446
137. Soap Mill,	447
138. Beyer's Plotting Machine,	448
139. Steam Jacketted Pan and Agitator,	452
140, 141. Hawes' Boilers for Cold Process Soaps,	457
142. Dunn's Plant for making Hydrated Soaps under Pressure,	463
143. Alder Wright's Chart of Hydrolysis of Soap Solutions,	488
144. Gerlach's Vaporimeter,	518

§ 1. General Composition and Nature of Oils, Butters, Fats, Waxes, and Allied Substances.

CHAPTER I.

THE SOURCES AND GENERAL NATURE OF NATURAL AND ARTIFICIAL OILS, &c.

AMONGST the alchemists the term "oil" had a somewhat wider range of application than is usual at the present day, including various inorganic substances, such as "oil of vitriol." Similarly "butter of antimony" and "butter of tin" were metallic derivatives entirely dissimilar from cow's butter in constitution, although resembling it in physical consistency. Even when such wholly inorganic compounds are excluded, the term "oil" has still an extremely elastic meaning, being employed to designate a very large variety of liquid substances, natural and artificial, which have but few features in common beyond the fact that, being all organic in character, they are capable of burning with more or less facility under suitable conditions; whilst with but very few exceptions they are practically insoluble in water, so as to be incapable of permanent solution therein; being as a rule lighter than water, when agitated therewith an emulsion forms, from which the water and oil gradually separate on standing, the latter usually floating as a separate layer on the former.

The term "fatty matter," or more shortly "fat," is applied to substances which are more or less of a soft solid character at the ordinary temperature, but on gently heating pass to liquids closely resembling fluid oils in general characters; "butters" being specially soft varieties of such fats possessing the peculiar physical texture of cow's butter at the atmospheric temperature of temperate climates. "Waxes," on the other hand, possess a somewhat different and much firmer texture at the ordinary temperature, but when heated melt to fluids which closely resemble ordinary liquid oils and melted fats in their general physical characters.

Oils proper are derived from animal, vegetable, and mineral sources, being mostly precontained in the tissues, seeds, or strata, &c., from which they are obtained by simple mechanical processes, such as pressure or pumping, or by means of solvents, or by volatilisation; certain products of destructive distillation, however, are also ranked amongst oils—*e.g.*, the “light oils,” “creosote oils,” &c., obtained during the rectification of coal tar; and “shale oils,” “bone oil” (Dippel’s oil, or bone tar), “paraffin oils,” “rosin oils,” and similar substances formed by the breaking up of more complex organic matters under the influence of heat. Somewhat similar substances (fusel oils) are produced by analogous decompositions occurring during fermentative changes.

Oils capable of being converted into vapour by the application of heat without suffering material decomposition (*volatile oils*) are for the most part either artificial products of destructive distillation, natural mineral oils (petroleum, very probably formed underground by the long-continued action of intra-terrestrial heat on subterranean organic matter), or “essential” oils—*i.e.*, volatile odorous matters extracted from numerous vegetable sources, usually by distillation along with water. *Fixed oils*, on the other hand, are substances not volatile without decomposition, and are essentially of animal and vegetable origin; as also are butters, fats, and waxes (which practically become fixed oils on slightly raising the temperature), with the exception of the so-called waxes of mineral origin, paraffin wax, ozokerite, cerasin, &c.*

From the point of view of general chemical composition, oils, fats, butters, and waxes may be divided into two leading classes—*viz.*, those consisting of carbon and hydrogen only (*hydrocarbons*); and those containing carbon, hydrogen, and oxygen. Oils, &c., of the former class are practically all volatile without decomposition; those of the second class are in some cases volatile without change (*e.g.*, oxidised essential oils), but, as a rule, are “fixed,” undergoing destructive distillation when heated, so that the vapours emitted are produced in consequence of decomposition.

Hydrocarbon oils include a large number of “essential oils” (in which oxidised substances are often present along with hydrocarbons); paraffin and petroleum oils, including the lightest and most volatile distillates of the “benzoline” class, “burning oils” (kerosenes, &c.) of medium volatility, “lubricating oils” of higher boiling point, and paraffin waxes, &c.; coaltar oils of

* The terms “fat” and “butter” are not confined to the fatty matters obtainable from the adipose tissues of animals and the milk of mammalia; thus, various vegetable fats and butters are known, *e.g.*, *Dika fat*, *Palm butter*, *Shea butter*, *vegetable tallow*, &c. Similarly, whilst animal waxes are the best known products of the wax class, various forms of vegetable wax occur in nature (*e.g.*, *Japanese wax* and *Carnauba wax*).

various kinds; and other analogous products of destructive distillation, from which various "closed chain" hydrocarbons (benzene, naphthalene, anthracene, &c.) are isolable, along with many other kinds of hydrocarbons, some of the "saturated" class (paraffins, indicated by the general formula C_nH_{2n+2}), some of the "unsaturated" classes (C_mH_{2n} , where n is not greater than m).

Oxidised oils (including fats, butters, and waxes), from the point of view of chemical constitution, are divisible into two classes—viz., those that are, and those that are not, of the nature of "compound ethers," or substances capable of undergoing changes of the character of that known as "saponification." Oils of the first class are again divisible into two groups—viz., *Glycerides*, or oils, &c., developing glycerol by saponification; and *Non-glycerides*, or oils not developing glycerol by saponification, but giving rise instead to some other alcoholiform product. As examples of these two groups may be mentioned, olive oil, coker* butter, mutton tallow, cow's butter, Japanese wax, linseed oil, colza oil, cod liver oil, and whale oil, essentially glyceridic in character; and oil of wintergreen (chiefly methyl salicylate), beeswax (mainly myricyl palmitate), spermaceti (chiefly cetylic palmitate), and sperm and doegling oils, essentially non-glyceridic in character.

Oils, &c., of the second class (non-saponifiable) include various oxidised essential oils belonging to different organic families—*e.g.*, *aldehydes*, such as oil of bitter almonds (benzoic aldehyde); *ketones*, like oil of rue (methyl nonyl ketone) and oil of tansy (methyl octyl ketone); *alcohols*, such as oil of geranium (geraniol); *camphor analogues*, such as oil of wormwood (absinthol); and *resinoid constituents*. Various alcoholiform substances are also contained in the free state in natural oils, greases, &c.; thus woolgrease contains *cholesterol*, and ambergris an allied body *ambreol*; whilst similar substances are found in small quantity in many vegetable oils. Higher alcohols (*e.g.*, *cetylic alcohol*) are often present in the free state in marine cetacean oils; whilst *phenol* and its homologues are present in coaltar oils and other products of destructive distillation.

SAPONIFICATION.

Originally the term "Saponification" was used to designate the chemical changes taking place when soap is prepared by the action of alkalis on fixed oils and fats; but subsequently it

* Although the spelling "coker" at first sight looks inelegant, it is convenient to employ it instead of "cocoa," in order clearly to distinguish the product of the cokernut palm (*Cocos nucifera*) from that of the cacao (chocolate plant yielding the beverage cocoa) and the *coca* (yielding the alkaloid cocaine).

Oils proper are derived from animal, vegetable sources, being mostly precontained in the tissues, &c., from which they are obtained by simple processes, such as pressure or pumping, or by means or by volatilisation; certain products of destruction, however, are also ranked amongst oils—*e.g.*, the “creosote oils,” &c., obtained during the rectification and “shale oils,” “bone oil” (Dippel’s oil, or bone oils), “rosin oils,” and similar substances formed by the decomposition of more complex organic matters under the influence of heat. Somewhat similar substances (fusel oils) are produced by the analogous decompositions occurring during fermentation.

Oils capable of being converted into vapour by the action of heat without suffering material decomposition are for the most part either artificial products of distillation, natural mineral oils (petroleum, &c., formed underground by the long-continued action of terrestrial heat on subterranean organic matter), or volatile oils—*i.e.*, volatile odorous matters extracted from numerous natural sources, usually by distillation along with water. Fixed oils, on the other hand, are substances not volatile under ordinary decomposition, and are essentially of animal and vegetable origin: as also are butters, fats, and waxes (which become fixed oils on slightly raising the temperature). The exception of the so-called waxes of mineral origin, ozokerite, cerasin, &c.*

From the point of view of general chemical composition, fats, butters, and waxes may be divided into two leading classes—*viz.*, those consisting of carbon and hydrogen only (hydrocarbons); and those containing carbon, hydrogen, and oxygen (oils, &c., of the former class are practically all volatile under ordinary decomposition; those of the second class are in some cases volatile without change (*e.g.*, oxidised essential oils), but in general, *viz.*, are “fixed,” undergoing destructive distillation when heated, so that the vapours emitted are produced in consequence of decomposition.

Hydrocarbon oils include a large number of “essential oils” (in which oxidised substances are often present along with the hydrocarbons): paraffin and petroleum oils, including the lightest and most volatile distillates of the “benzoline” class, “burning oils” (kerosenes, &c.) of medium volatility, “lubricating oils” of higher boiling point, and paraffin waxes, &c.; coal-tar

* The terms “fat” and “butter” are not confined to the fatty matters obtainable from the adipose tissues of animals and the milk of mammals; thus various vegetable fats and butters are known, *e.g.*, *Dika fat*, *hemp butter*, *Sassa butter*, *vegetable tallow*, &c. Similarly, whilst animal waxes are the best known products of the wax class, various forms of vegetable wax occur in nature (*e.g.*, *Japanese wax* and *Carnauba wax*).

of glyceridic char-
f *palmitic glyceride*,

al oils also consist
thus oil of winter-
of *methyl salicylate*,
) of *octyl acetate* ;

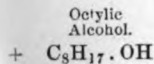
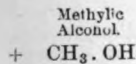

lic alcohols on
amongst natural
are ; carnauba

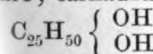

like those of
tients of oils
et more com-
C₆H₈(OH)₆,
ent of vege-
olives ; but
e contained

S, &c.,
ON.

n of the
nce with
ents :—

and the pro-
osene oils,
shale oils,

&c.) or
allied

SAPONIFICATION.

"Saponification" was used to designate
changes taking place when soap is prepared by
fixed oils and fats ; but subsequently it

"color" at first sight looks inelegant, it is con-
in order clearly to distinguish the
Cocaine (yielding the alkaloid
the coca (yielding the alkaloid
to distinguish
of the coca is
(yielding quinine).

... it is con-
... tinguish the
... cacao (choco-
... alkaloid
... cacao (choco-
... quinine
... it is con-

has been extended to include a large number of parallel changes occurring where various classes of "compound ethers" are broken up under the influence of alkalis or other bases, so as to give rise, on the one hand, to the metallic salt of an organic acid, and, on the other, to an alcoholiform complementary product. The following equations represent typical reactions of saponification, according as the alcoholiform product is an alcohol of the monohydric, dihydric, trihydric, or tetrahydric class:—

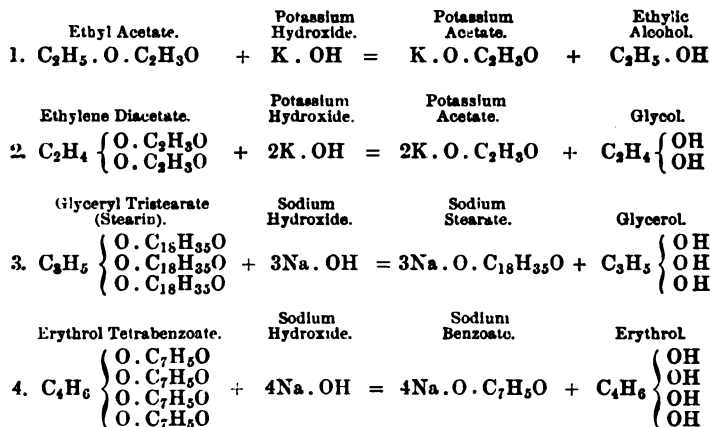

The majority of saponification changes occurring with natural fixed oils and fats, &c., belong to the third class; *i.e.*, these substances are chiefly "glycerides," or compound ethers furnishing glycerol on saponification; some liquid fixed saponifiable oils, however, are of non-glyceridic character, undergoing saponification changes of the first kind; thus sperm oil largely consists of *cetylic physetoleate* and homologous substances, broken up by saponification, thus—

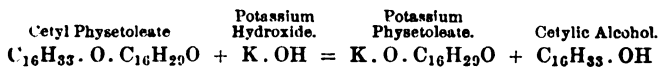

Most waxes possess an analogous constitution; thus the chief constituents of beeswax and spermaceti are respectively *myricyl palmitate* and *cetyl palmitate*, decomposable by saponification, thus—

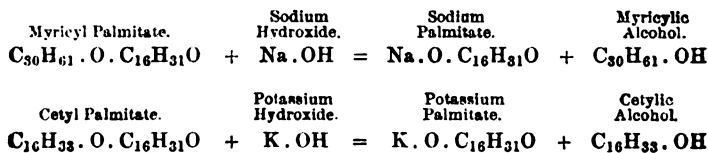

Some few vegetable waxes, however, are of glyceridic character, *e.g.*, Japanese wax, chiefly consisting of *palmitic glyceride*, $C_3H_5(O.C_{16}H_{31}O)_3$.

A considerable number of oxidised essential oils also consist mainly of compound ethers of the first class; thus oil of winter-green (*Gaultheria procumbens*) mainly consists of *methyl salicylate*, and oil of cow parsnep (*Heracleum spondylium*) of *octyl acetate*; respectively saponified, thus—

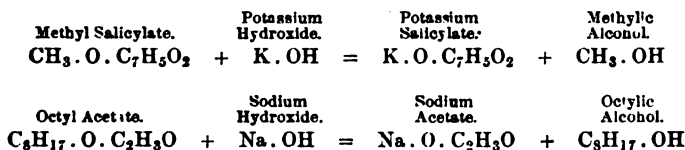

Compound ethers of Class II. (furnishing dihydric alcohols on saponification), although not absolutely unknown amongst natural products of the oil, fat, and wax class, are very rare; carnauba wax has been found to yield (*inter alia*) a glycol, $C_{25}H_{50} \begin{cases} OH \\ OH \end{cases}$ on saponification (p. 18). Tetrahydric ethers, like those of erythrol, have not as yet been recognised as constituents of oils and fats, &c.; and the same remark applies to the yet more complex pentahydric and hexhydric ethers; mannitol, $C_6H_8(OH)_6$, a hexhydric alcohol, has been found as a constituent of vegetable fruits, &c., accompanying oil—*e.g.*, in unripe olives; but neither mannitol nor any ethers thereof appear to be contained in purified expressed olive oil.

CLASSIFICATION OF OILS, FATS, WAXES, &c., ACCORDING TO CHEMICAL COMPOSITION.

The following table indicates a rough classification of the principal varieties of oils, fats, and waxes in accordance with the general chemical character of their leading constituents:—

DIVISION I.—HYDROCARBONS.

1. Natural essential oils, mostly of vegetable origin.
2. Natural mineral oils (petroleum), including the crude oils, and the products thence obtained by distillation, &c. (benzoline, kerosene oils, lubricating oils, &c.)
3. Artificial products of destructive distillation (paraffin oils, shale oils, bone oils, coaltar oils, &c.)
4. Solid hydrocarbons obtainable from natural products (earthwax, &c.) or isolated from the two previous sources—*e.g.*, paraffin wax and allied substances largely used in candle-making.

DIVISION II.—CONTAINING OXYGEN.

A.—Saponifiable.

1. *Essentially compound ethers of monohydric alcohols.*
 - a. Various natural essential oils mostly of vegetable origin.
 - b. Certain animal fixed oils, especially those of cetacean origin (sometimes termed "liquid waxes").
 - c. Most animal and vegetable solid waxes (waxes proper).
 - d. Certain artificial essential oils—*e.g.*, various compound ethers used for perfumery and flavouring purposes.
2. *Essentially glycerites, or compound ethers of glycerol.*
 - a. The majority of animal and vegetable fixed oils, fats, and butters.
 - b. Some few vegetable waxes.

B.—Not Saponifiable.

- a. Various essential oils, consisting of aldehydes, ketones, camphoraceous bodies, &c.
- b. Alcoholiform constituents of natural animal and vegetable oils (cholesterol, phytosterol, cetylic alcohol, &c.)
- c. Alcoholiform bodies formed by fermentation (fusel oils).
- d. Phenoloid bodies formed by destructive distillation and contained in coaltar, &c. (phenol, cresol, &c.)
- e. Products formed by oxidation of hydrocarbons—*e.g.*, "Sanitas oil" (formed by the atmospheric oxidation of oil of turpentine).

In the present work a large number of the various substances thus coming into the general category of oils, fats, butters, and waxes are necessarily excluded from minute consideration, fixed animal and vegetable oils and fats, &c., all practically belonging to Division II., Sections 1 and 2. Certain hydrocarbons, however, are intimately connected with the subjects dealt with, more especially mineral oils and products of destructive distillation employed as adulterants of animal and vegetable fixed oils, and as ingredients in lubricating mixtures, &c.; and mineral waxes (paraffin wax, ozokerite, and similar substances) employed as candle materials. Various essential oils, moreover, are in use as ingredients in certain kinds of fancy (toilet) soaps as perfuming agents, and in some kinds of sanitary soaps (*e.g.*, eucalyptus oil); as also are certain products of destructive distillation (*e.g.*, carbolic acid and its higher homologues).

For further classifications of fixed oils, fats, waxes, &c. (apart from other kinds of oils), based either on their physical characters and the chemical nature of their main ingredients, or on their leading technical uses, *vide* Chap. XIII.

CHAPTER II.

SAPONIFICATION PRODUCTS OF OILS, FATS,
WAXES, &c.

ALCOHOLIFORM PRODUCTS.

A SAPONIFIABLE oil, &c., as above stated, gives rise to two products under the influence of alkalies—*viz.*, an alcoholiform organic substance (which in practice is either glycerol or some kind of monohydric alcohol), and the alkali salt of an organic acid. Under suitable conditions (more especially heating under pressure in contact with water) parallel decompositions can be brought about by means of water, the products of the “hydrolysis” thus effected being the alcoholiform body and a free “fatty acid.” Thus in the cases of the glyceride of oleic acid and of cetyl palmitate the hydrolytic actions take place in accordance with the following equations:—

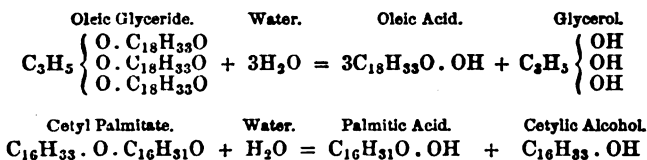

Similar reactions occur in many other parallel cases, the nature of the alcoholiform body and of the fatty acid developed only differing in each instance.

TRIHYDRIC ALCOHOLS FORMED BY SAPONIFICATION (GLYCEROL).

Glycerol, the most frequently occurring alcoholiform saponification product of fixed oils and fatty matters, solidifies, when pure, to a crystalline mass by long continued chilling,* the melting point being about + 22° C.; its great hygroscopic character renders it extremely difficult to obtain absolutely free from water, in consequence of which values varying from 1.262 to 1.2653 have

* Passing a few bubbles of chlorine into concentrated glycerol will often make it crystallise (Werner). Chilled glycerol usually crystallises when stirred up with a few crystals of the previously solidified substance, a method utilised in manufacture (Chap. XXII.)

CHAPTER I - INTRODUCTION

1 - INTRODUCTION

The present work is a study of the various substances that come under the general category of oils, fats, butters, and waxes and is necessarily confined to an outline consideration, fixed oils and vegetable oils and fats, all practically belonging to Division III, Sections 1 and 2. Certain hydrocarbons, however, are intimately connected with the subjects dealt with, more especially mineral oils and products of destructive distillation employed as substitutes of animal and vegetable fixed oils, and as ingredients in perfuming mixtures, &c.; and mineral waxes, paraffin wax, ceresine, and similar substances, employed as coloring materials. Various essential oils, moreover, are in use as ingredients in certain kinds of fancy toilet soaps as perfuming agents, and in some kinds of salinary soaps (e.g., eucalyptus oil); as also are certain products of destructive distillation (e.g., carbonic acid and its higher homologues).

1 - INTRODUCTION

The present work is a study of the various substances that come under the general category of oils, fats, butters, and waxes and is necessarily confined to an outline consideration, fixed oils and vegetable oils and fats, all practically belonging to Division III, Sections 1 and 2. Certain hydrocarbons, however, are intimately connected with the subjects dealt with, more especially mineral oils and products of destructive distillation employed as substitutes of animal and vegetable fixed oils, and as ingredients in perfuming mixtures, &c.; and mineral waxes, paraffin wax, ceresine, and similar substances, employed as coloring materials. Various essential oils, moreover, are in use as ingredients in certain kinds of fancy toilet soaps as perfuming agents, and in some kinds of salinary soaps (e.g., eucalyptus oil); as also are certain products of destructive distillation (e.g., carbonic acid and its higher homologues).

In the present work a more detailed study of the various substances that come under the general category of oils, fats, butters, and waxes are necessarily confined to an outline consideration, fixed oils and vegetable oils and fats, all practically belonging to Division III, Sections 1 and 2. Certain hydrocarbons, however, are intimately connected with the subjects dealt with, more especially mineral oils and products of destructive distillation employed as substitutes of animal and vegetable fixed oils, and as ingredients in perfuming mixtures, &c.; and mineral waxes, paraffin wax, ceresine, and similar substances, employed as coloring materials. Various essential oils, moreover, are in use as ingredients in certain kinds of fancy toilet soaps as perfuming agents, and in some kinds of salinary soaps (e.g., eucalyptus oil); as also are certain products of destructive distillation (e.g., carbonic acid and its higher homologues).

For further classifications of fixed oils, fats, waxes, &c. (apart from other kinds of oils) based either on their physical characters and the chemical nature of their main ingredients, or on their leading technical uses, *vide* Chap. XIII.

sh) the
[t does
finitely
to it,
ly pro-

CHAPTER II.

SAPONIFICATION PRODUCTS OF OILS, FATS,
WAXES, &c.

absor-
n any

ALCOHOLIFORM PRODUCTS.

A SAPONIFIABLE OIL, &c., as above stated, gives rise to a series of products under the influence of alkalis — such as the soap, a substance which in practice is either a mixture of monovalent alcohol, and the alkali salt of the corresponding conditions (more especially in the case of olive oil in contact with water) parallel to the above, but brought about by means of water, the products being thus effected being the alcoholiform acids. Thus in the cases of the palmitic acid palmitate the hydrolytic actions are represented by the following equations:—

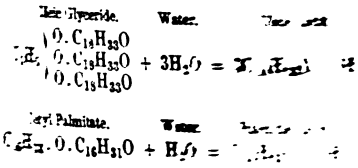

Similar reactions occur in many other cases of the alcoholiform bodies, and are all differing in each instance.

TRIHYDRIC ALCOHOLIFORM PRODUCTS.

Glycerol, the most important of these products, is a pure, to a certain extent, point being that it extremely conspecific

rely
as a
st it
e of
ol;
lily
de,

it,
of
to
n-
re
ce
pe
an
lat
n;
to
ase

been stated as its specific gravity at 15°. When heated gently under the ordinary atmospheric pressure it volatilises without decomposition, but at higher temperatures it splits up into water and *acrolein*, thus—



In *vacuo* it boils at about 180° C.

By cautious oxidation with alkaline permanganate it yields oxalic acid in sufficiently accurate proportions for quantitative estimation. By treatment with potassium dichromate and sulphuric acid it similarly forms CO₂ and water; by treatment with acetic anhydride it forms triacetin, the saponification of which furnishes another means of quantitative determination (*vide* Chap. XXII.) In the absence of substances carbonised by sulphuric acid, an excellent qualitative test is to heat cautiously to 120° or a little higher a mixture of two drops glycerol, two of fused phenol, and about as much sulphuric acid; a brown solid mass forms, which after cooling dissolves in ammonia with a beautiful carmine red colour (Reichl); if substances becoming carbonised are present they produce a dark brown colouring matter which hides the red tint.

Polyglycerols.—Glycerol heated in contact with hydrochloric acid or certain other dehydrating substances is capable of undergoing reactions of dehydration and condensation, expressible by the general equation :—



Thus when $n = 2$ and $m = 1$, *diglycerol* results.

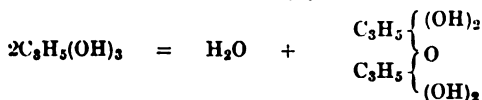

And when $n = 3$ and $m = 2$, *triglycerol* is produced.

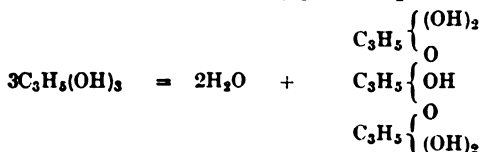

It has been supposed by some chemists that bodies of this class are sometimes contained in commercial "glycerines," more especially those formed under high pressure in autoclaves, or purified by distillation; such glycerine, when slowly evaporated at a temperature of about 160° C.,* leaves a non-volatile organic

* Lewkowitsch, *Year Book of Pharmacy*, 1890, p. 380.

residue, from the weight of which (after deducting ash) the proportion of polyglycerols present may be deduced. It does not appear, however, that the residue thus left has been definitely proved to have the character and composition assigned to it, although the formation of polyglycerols is, *a priori*, highly probable.

Natural Triglycerides.—As a very general, if not absolutely invariable, rule, *only one acid radicle* is contained in any given substance—*i.e.*, substances of the types

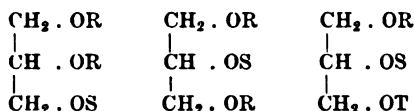

(where R, S, and T are not the same) are only extremely rarely met with. Cow's butter, however, not improbably contains a mixed glyceride of one or other of these classes; for whilst it forms butyric acid on saponification, no butyrin (triglyceride of butyric acid) can be dissolved out from it by means of alcohol; whereas mixtures of butyrin and other triglycerides readily yield the former to that solvent; hence a mixed glyceride, *oleo palmito butyric glyceride*,

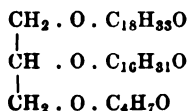

(or some analogous substance) has been supposed to be present, breaking up on saponification into glycerol, with formation of salts of oleic, palmitic, and butyric acids.

Some few other fats have been supposed, on similar grounds, to contain analogous mixed glycerides; but, as a general rule, whenever an oil or fat yields on saponification the salts of two or more different fatty acids, it can be shown that the original substance is a mixture of two or more triglycerides of the ordinary type (*i.e.*, each containing only one acid radicle); thus, by chilling an oil yielding palmitic and oleic acids on saponification, a solid fat usually separates, yielding only palmitic acid on saponification; whilst the liquid portion is substantially olein, giving rise to oleic acid only on similar treatment, the reaction in each case being indicated by the general equation:—

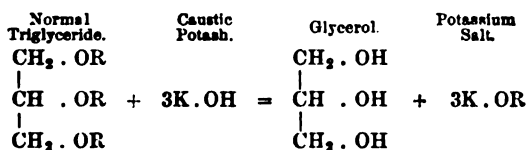

the effect of the alkali being always the same, the only differences in different cases being due to the variation in the nature of R.

Hydrolysis of Glycerides.—As a general rule, pure triglycerides are acted upon by water only at an elevated temperature, treatment with superheated steam blown through the mass, or digestion with water under considerable pressure being requisite; under such circumstances, the glycerol set free is often more or less decomposed by secondary reactions. With crude unpurified oils continued standing at the ordinary temperature often suffices, the action in such cases being largely due to changes of a fermentative character taking place in the mucilaginous or albuminous extractive matters present as impurities; in extreme cases the action goes on to such an extent as to hydrolyse the larger portion of the glycerides present, so that upwards of 50 per cent. of the mass is free fatty acid. Changes of this description are almost invariably accompanied by the production of bye-products of unpleasant taste and smell, so that the development of "rancidity" by this action greatly deteriorates the value of the oil, &c., for many purposes, more especially culinary and edible ones.

In all probability the formation of a free fatty acid and glycerol from a glyceride by hydrolytic action takes place in three stages, giving rise to two kinds of intermediate products, *diglycerides* and *monoglycerides* respectively; thus, if R be a fatty acid radicle—

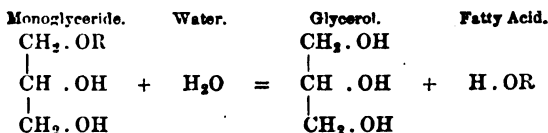
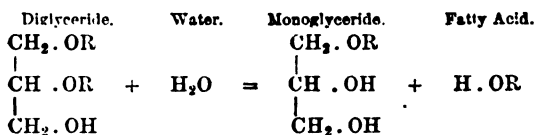
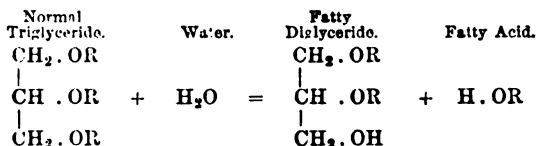

The final action may consequently be expressed by the equation—

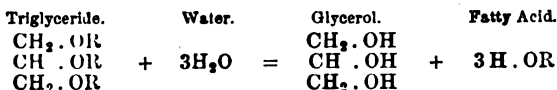

which may be written somewhat more compactly—

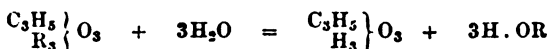

The formation of the intermediate substances by gradual hydrolysis has not been much studied as yet; in the case of rape oil, however, it has been shown that whilst fresh oil contains the triglyceride *erucin*,

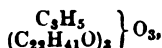

the corresponding diglyceride *dierucin*,

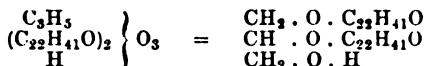

is sometimes contained in old oil,* probably formed as above by partial hydrolysis. On the other hand, the reverse reactions leading to the successive building up from glycerol of monoglyceride, diglyceride, and triglyceride are well known laboratory operations: thus—

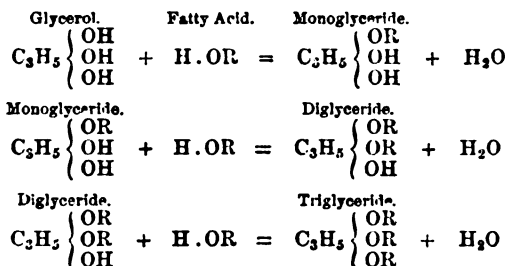

In many cases, when it is desired to obtain triglycerides in a state of purity, it is more easy to saponify an oil, separate and purify the resulting fatty acids, and convert them into glycerides in this way than it is to separate the original glycerides themselves contained in the oil.

The following boiling and melting points are possessed by some pure triglycerides prepared synthetically in this way:—

	Melting Point.	Boiling Point.
Butyrin, C ₂ H ₅ (O · C ₄ H ₇ O) ₃	Fluid	285°
Laurin, C ₃ H ₅ (O · C ₁₂ H ₂₃ O) ₃	45°	...
Myristin, C ₃ H ₅ (O · C ₁₄ H ₂₇ O) ₃	55	...
Palmitin, C ₃ H ₅ (O · C ₁₆ H ₃₁ O) ₃	62	...
Stearin, C ₃ H ₅ (O · C ₁₈ H ₃₅ O) ₃	71·5	...
Olein, C ₃ H ₅ (O · C ₁₈ H ₃₃ O) ₃	solidifies at - 6°	...

* Reimer and Will (*Berichte der Deut. Chem. Ges.*, 1886, xix., p. 3320) found that a deposit which had slowly formed in a quantity of colza oil was not the triglyceride usually obtained under such conditions, but the diglyceride melting at 47°.

When oils that have become hydrolysed through rancidity are refined by treatment with alkalis (Chap. xi.), the free acids are removed and neutral oils left; but other kinds of refining processes do not affect the free acids, which accordingly are apt to be found in commercial oils to varying extents, sometimes only inconsiderable amounts, and sometimes very large percentages being present. According to Thum the free acids do not consist solely of oleic acid, as is often supposed, but of a mixture in exactly the same proportions as that in which they exist in the undecomposed glycerides. Thus palm oil and olive kernel oil containing much free acid yield as much solid free acids relatively to oleic acid when the free acids are removed by agitation with a cold alkaline ley, as are yielded by the neutral unsaponified fats present.

Just as the glyceridic compound ethers of fatty acids are apt to be hydrolysed under appropriate conditions, so are their alkaline salts (soaps) split up by water with the formation of basic substance (free alkali) and an acid salt (*vide* p. 23).

It is a remarkable fact that although a somewhat considerable number of monohydric alcohols are known to be formed by the saponification of fixed oils, essential oils, and similar substances, only one trihydric alcohol, viz., glycerol, has ever been found to be produced from such sources.

Isoglyceride Theory.—Theoretically the existence is possible of various substances possessing the composition of a trihydroxylated propane, $C_3H_5(OH)_3$, but not identical with glycerol: these substances would naturally form compound ethers isomeric with ordinary glycerides containing the same acid radicles. Amongst such hypothetical bodies, the compound ethers of *ortho-propionic acid*, indicated by the general formula—

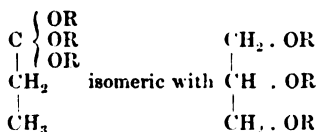

have been supposed by some chemists to be present in certain fatty matters, notably cow's butter; but the experimental proofs of this supposition are singularly wanting in clearness and cogency. Such compound ethers on saponification should neutralise four instead of three equivalents of alkali, generating an alkaline propionate instead of glycerol; thus—

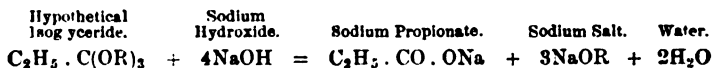

MONOHYDRIC ALCOHOLS FORMED BY SAPONIFICATION.

Numerous families of alcohols (monohydroxylated hydrocarbons) are known to the chemist, derived successively from saturated hydrocarbons of the series $C_n H_{2n+2}$, and from the other series of hydrocarbons containing less hydrogen, by the replacement of hydrogen by hydroxyl: thus *inter alia* the following families of alcohols are known:—

Ethylic alcohol homologues; general formula,	$C_n H_{2n+1} \cdot OH$
Allylic " " " "	$C_n H_{2n-1} \cdot OH$
Phenol " " "	$C_n H_{2n-7} \cdot OH$
Cinnamic alcohol " " "	$C_n H_{2n-9} \cdot OH$

Although representatives of several such families of alcohols are found amongst products of destructive distillation (coal-tar oils, &c.), and in essential oils and the allied balsams and other aromatic bodies, and in small quantities as natural constituents of fixed oils of various kinds (occurring there in the free state), yet compound ethers derived from alcohols of the first and second of the above families appear to be the only kinds naturally occurring in fixed oils and waxes, &c.; and of these by far the most frequently occurring substances belong to the first class.

Ethylic Series of Alcohols.—The table on next page indicates the leading alcohols of this family (general formula $C_n H_{2n+1} \cdot OH$) derived from fixed and essential oils and similar sources; besides those mentioned numerous isomeric modifications of many of them exist, obtainable artificially by laboratory reactions.

The higher alcohols of this series, when fused with alkalis, evolve hydrogen with formation of the alkali salt of the corresponding fatty acid;* thus—

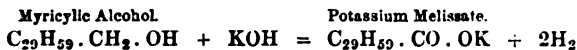
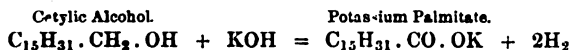

They are readily converted into compound ethers by treatment with organic anhydrides (*e.g.*, acetic anhydride), and in some cases by heating with the acids alone, water being evolved.

* C. Hell (Liebig's *Annalen*, pp. 223, 269) has based a method for the quantitative determination of higher alcohols on this reaction, the substance to be examined being heated to 300°-310° in contact with soda lime, and the evolved hydrogen collected and measured. At higher temperatures there is a possibility of hydrogen being also evolved by the action of caustic alkalis on oleic acid (p. 24). This method has been found useful in the examination of beeswax which, when genuine, furnishes about 54 per cent. of myricylic alcohol.

Name.	Formula.	Boiling Point	Melting Point.	Sources.
Methylic alcohol,	$\text{CH}_3 \cdot \text{OH}$	66°C.	...	Saponification of oil of winter-green; wood distillation products.
Ethylic alcohol,	$\text{C}_2\text{H}_5 \cdot \text{OH}$	78°	...	Fermentation of saccharine matter.
Propylic alcohol,	$\text{C}_3\text{H}_7 \cdot \text{OH}$	97°	...	Fermentation fusel oils.
Isopropylic alcohol,		84°	...	Isopropylic iodide from glycerol and hydriodic acid.
Normal Butylic alcohol,	$\text{C}_4\text{H}_9 \cdot \text{OH}$	117°	...	Heavy oils from brandy.
Isobutylic alcohol		107°	...	Potato and beet fusel oils.
Amylic alcohols (several isomeric modifications),	$\text{C}_5\text{H}_{11} \cdot \text{OH}$	127°-133°	...	Fusel oils from grain spirit, &c. Saponification of oil of Roman Chamomile.
Hexylic alcohols (several modifications),		$\text{C}_6\text{H}_{13} \cdot \text{OH}$	147°-157°	...
Normal Primary Heptylic alcohol,	$\text{C}_7\text{H}_{15} \cdot \text{OH}$	176°	...	Brandy fusel oils. Hydrogenation of <i>anethol</i> from castor oil.
Octylic alcohols,	$\text{C}_8\text{H}_{17} \cdot \text{OH}$	180°-192°	...	Saponification of oil of <i>Heraclium spondylium</i> and <i>H. giganteum</i> . Action of hot alkali on castor oil.
Nonylic alcohols,	$\text{C}_9\text{H}_{19} \cdot \text{OH}$
Normal Primary Decylic alcohol,	$\text{C}_{10}\text{H}_{21} \cdot \text{OH}$	119° at 15 millims. pressure.	7°C.	Hydrogenation of capric aldehyde.
Secondary Hendecylic alcohol,	$\text{C}_{11}\text{H}_{23} \cdot \text{OH}$	229°	...	Hydrogenation of oil of rue.
Dodecylic alcohols,	$\text{C}_{12}\text{H}_{25} \cdot \text{OH}$	143° at 15 millims. pressure.	24°	Hydrogenation of lauric aldehyde.
		19°	Saponification of sperm oil.	
Tridecylic alcohols,	$\text{C}_{13}\text{H}_{27} \cdot \text{OH}$
Normal Primary Tetradecylic alcohol,	$\text{C}_{14}\text{H}_{29} \cdot \text{OH}$	167° at 15 millims. pressure.	38°	Hydrogenation of myristic aldehyde.
	
Pentadecylic alcohols,	$\text{C}_{15}\text{H}_{31} \cdot \text{OH}$
Normal Primary Hexadecylic alcohol,	$\text{C}_{16}\text{H}_{33} \cdot \text{OH}$	189°·5 at 15 millims. pressure.	40°·5	Hydrogenation of palmitic aldehyde.
Cetylic alcohol,		188°-193° at 15 mm. pressure.	49°·2	Saponification of spermaceti.
Heptadecylic alcohols,	$\text{C}_{17}\text{H}_{35} \cdot \text{OH}$
Normal Primary Octodecylic alcohol,	$\text{C}_{18}\text{H}_{37} \cdot \text{OH}$	210°·5 at 15 millims. pressure.	59°	Hydrogenation of stearic aldehyde. Saponification of spermaceti (in small quantity).
Cerylic alcohol,	$\text{C}_{27}\text{H}_{55} \cdot \text{OH}$...	79°	{ Chinese wax. Carnauba wax. Wax of <i>Ficus gummiiflua</i> .
Isocerylic alcohol,			62°	
Myricylic alcohol,	$\text{C}_{30}\text{H}_{61} \cdot \text{OH}$...	85°	Beeswax.
Isomyricylic alcohol?			72°	

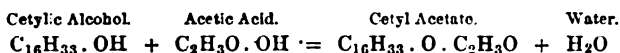
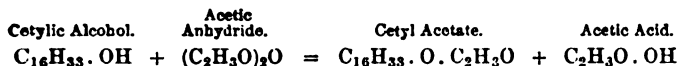

The compound ethers thus produced are, in turn, readily saponified by alcoholic potash, and from the amount of potash neutralised during the operation the molecular weight of the alcohol is deducible, due corrections being made for unsaponifiable matters, &c., if present (Chap. VIII.)

Allylic Series of Alcohols.—Alcohols of the series $\text{C}_n\text{H}_{2n-1} \cdot \text{OH}$, derived from the olefine family of hydrocarbons of formula C_nH_{2n} , are only sparsely represented amongst the derivatives from natural products. Acrolein (acrylic aldehyde), $\text{C}_2\text{H}_3 \cdot \text{CHO}$, by hydrogenation yields *allylic alcohol*, $\text{C}_2\text{H}_3 \cdot \text{CH}_2 \cdot \text{OH}$ (also obtainable in various other ways), existing as a thiocyanic ether in the oils of black mustard seed, horse radish, and garlic; whilst higher homologues are probably contained amongst the alcohols of the previous series obtained on saponifying sperm oil, since in certain cases a deficiency of hydrogen is observed on analysis, coupled with a strongly marked tendency to combine directly with iodine, indicating the presence of unsaturated compounds. These higher alcohols, however, have not as yet been isolated from the other bodies accompanying them in a state of sufficient purity to admit of their formulæ being exactly determined. *Borneol*, $\text{C}_{10}\text{H}_{19} \cdot \text{OH}$, occurs in the camphor of *Dryobalanops camphora*, and to a small extent in oil of valerian and oil of rosemary.

Alcohols of the series $\text{C}_n\text{H}_{2n-3} \cdot \text{OH}$, derived from the $\text{C}_n\text{H}_{2n-2}$ (acetylene) series of hydrocarbons, are found to some extent in certain essential oils—*e.g.*, *geraniol*, $\text{C}_{10}\text{H}_{17} \cdot \text{OH}$, in Indian geranium oil. This appears to be a true analogue of ethylic and allylic alcohols, being capable of yielding by oxidation an aldehyde and a monobasic acid (*geranic acid*) $\text{C}_9\text{H}_{15} \cdot \text{COH}$ and $\text{C}_9\text{H}_{15} \cdot \text{CO} \cdot \text{OH}$ respectively: no substances of analogous character have as yet been isolated from fixed oils and fats, &c.

Phenol and its Homologues.—Alcohols derived from hydrocarbons still poorer in hydrogen are occasionally met with as constituents of natural products of the resinous class, or as substances formed by destructive distillation; thus the hydrocarbons of the benzene family, $\text{C}_n\text{H}_{2n-6}$, give rise to two such classes of alcohols, both indicated by the general formula $\text{C}_n\text{H}_{2n-7} \cdot \text{OH}$ and derived from the same parent body, *phenol*, $\text{C}_6\text{H}_5 \cdot \text{OH}$. In the one class (*phenols proper*) the hydroxyl group is situated in connection with the "benzene nucleus" of 6 carbon atoms; and in the other (*benzylic alcohol series*) the hydroxyl group is not situated in the benzene radicle, but in one of the "side chains"

introduced by the methylation of benzene so as to develop homologous hydrocarbons ; thus—

Phenols.		
Phenol (carbolic acid),	. . .	$C_6H_5 \cdot OH$
Cresol (methyl phenol),	. . .	$C_6H_4 \left\{ \begin{array}{l} CH_3 \\ OH \end{array} \right.$
Xylenol (dimethyl phenol),	. . .	$C_6H_3 \left\{ \begin{array}{l} CH_3 \\ CH_3 \\ OH \end{array} \right.$
Phlorol (ethyl phenol),	. . .	$C_6H_4 \left\{ \begin{array}{l} C_2H_5 \\ OH \end{array} \right.$
Benzylic Alcohol Series.		
Benzylic alcohol,	. . .	$C_6H_5 \cdot CH_2 \cdot OH$
Xylylic alcohol,	. . .	$C_6H_4 \left\{ \begin{array}{l} CH_3 \\ CH_2 \cdot OH \end{array} \right.$
Benzylic carbinol,	. . .	$C_6H_5 \cdot CH_2 \cdot CH_2 \cdot OH$

Alcohols of the phenol class are mostly contained in the tars derived from the destructive distillation of coal, wood, &c. : *benzylic alcohol* is contained as such in the volatile oil of cherry laurel, and in the form of a compound ether in Balsam of Peru and Liquid Storax ; a higher homologue, *syccocerylic alcohol*, $C_{18}H_{29} \cdot OH$, is similarly found as an acetic compound ether in the resin of *Ficus rubiginosa* : α -*lactucerosol* and β -*lactucerosol* are two isomerides thereof contained as acetic ethers in lettuce juice. *Quebrachol* (from Quebracho bark), and *cupreol* and *cinchol* (from Cinchona barks) are analogous substances isomeric with one another and indicated by the higher homologous formula, $C_{20}H_{33} \cdot OH$; whilst *Phasol* (from *Phaseolus vulgaris*) is a lower homologue, $C_{15}H_{23} \cdot OH$. All these substances are closely akin to *cholesterol*, *isocholesterol*, *phytosterol* and *paraphytosterol*, alcoholiform substances belonging to the family derived from the hydrocarbons, C_nH_{2n-6} , and occurring in various fixed oils as normal constituents dissolved in the glycerides, &c., constituting the bulk of the oils. It is extremely probable that other analogous substances are also similarly contained in oils, &c., but as yet this has not been demonstrated to be the case. In the husks of *Phaseolus vulgaris* both *paraphytosterol* and *phasol* are present ; when such substances occur in the vicinity of oil-containing tissues, obviously any process applicable for the extraction of the oil is extremely likely to dissolve out more or less of the accompanying alcoholiform substances, as well as any other substances soluble in oil that may happen to be contained in the seeds, &c., operated upon.

Cholesterol Series and Analogues.—Cholesterol and its isomerides appear to be homologues of *cinnamic alcohol*, $C_9H_9 \cdot OH$ (contained in storax as cinnamic ether), indicated by the formula $C_{26}H_{43} \cdot OH$; some (cholesterol—long known as a bile constituent

—and isocholesterol) chiefly occur in oils, &c., of animal origin, such as whale and fish oils and woolgrease; others (phytosterol and isophytosterol) are similarly found in vegetable oils, such as olive oil. *Ambergris* and *castoreum* (from the Castor beaver) also appear to contain related substances (*ambreol* and *castorol* respectively). All these bodies, like the sycocerylic alcohol and its homologues above mentioned, are of alcoholiform character readily yielding acetic and benzoic compound ethers (often of highly crystalline character, and readily purified in consequence), the melting points of which are characteristic. Thus, cholesterol heated with benzoic anhydride (preferably in a sealed tube at 200°) forms a compound ether almost insoluble in boiling alcohol, but crystallisable from ether in right-angled tables, melting at 150°–151°. The following table illustrates some of the differences between cholesterol and its isomerides:—

	Melting Point.	Action on Polarised Light	Melting Point of Benzoic Ether.
Cholesterol, . .	147°	Lævogyrate.	150°-151°
Isocholesterol, .	137°-138°	Dextrogyrate.	190°-191°
Phytosterol, . .	132°-133°	Lævogyrate.
Paraphytosterol,	149°-150°	Dextrogyrate.

When dissolved in chloroform and treated with an equal volume of sulphuric acid, cholesterol yields a blood red coloration, soon becoming cherry red and purplish, permanent for several days; the acid underlying the chloroform solution exhibits a strong green fluorescence. Phytosterol gives a similar coloration, becoming a bluish red on standing some days; whilst isocholesterol gives no colour at all. On treatment with acetic anhydride, compound ethers are produced in each case, the "acetyl number" of which is 135·5 (parts of caustic potash, KOH, neutralised by the acetic acid developed by the saponification of 1,000 parts of compound ether, Chap. VIII.); the corresponding values for the similar compound ethers obtained from cetylic, cerylic, and myricylic alcohols being respectively 197·5, 128·1, and 116·7.

Another substance closely akin to phytosterol has been isolated from the seeds of *Lupinus luteus*, i.e., *lupeol*,* probably indicated by the formula $C_{26}H_{42}O$, containing less hydrogen than phytosterol; this melts at 204°, is dextrorotatory, and forms benzoic and acetic ethers melting respectively at 250° and 230°; dissolved in chloroform and treated with acetic anhydride and sulphuric acid, it gives a reddish coloration, becoming intensely violet red on standing. Several other substances of analogous character appear to be contained in various vegetable products—e.g., *hydro-*

* *Likiernik, Berich'e Deut. Chem. Ges.*, 1891, xxiv., pp. 183 and 187.

carotin (carrots), *paracholesterol* (*Ethalium septicum*), &c., &c.; but their occurrence in oil-bearing seeds, and the oils thence obtainable, has not yet been substantiated.

GLYCOLS.

It has been shown by Stürke * that when carnauba wax is saponified, and the alcoholiform constituents thus set free fractionated by means of petroleum, a glycol is obtained melting at 103·5 to 103·8, and giving numbers on analysis agreeing with the formula $C_{25}H_{52}O_2$, or $C_{23}H_{46} \left\{ \begin{array}{l} CH_2 \cdot OH \\ CH_2 \cdot OH \end{array} \right.$; this product evolves eight hydrogen atoms on fusion with caustic alkalies, forming an acid of the oxalic series, thus—

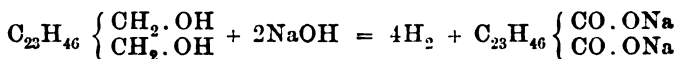

just as cerylic alcohol and similar bodies evolve four hydrogen atoms (p. 13), forming an acid of the stearic series, thus—

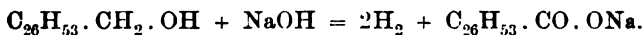

CHAPTER III.

SAPONIFICATION PRODUCTS OF OILS, FATS, WAXES, &c.

FATTY ACIDS.

It is a remarkable fact that all known compound ethers contained in natural fixed oils and fats, &c., invariably give rise on saponification to *monobasic* acids only, dibasic acids (like oxalic acid), and acids of still higher basicity being conspicuous by their absence from the products thus formed, although in many cases readily obtainable from these products by simple operations in the laboratory.

At least six different families of monobasic acids are represented amongst the saponification products of fixed oils, &c., four of which are included in the general formula, $C_m H_{2m+1} \cdot CO \cdot OH$; according as $m = n$, or $n + 1$, $n + 2$, or $n + 3$, this general formula represents the following families:—

Formula of Acid.	Family.
$C_m H_{2m+1} \cdot CO \cdot OH$	Acetic (or stearic) series.
$C_m H_{2m-1} \cdot CO \cdot OH$	Acrylic (or oleic) series.
$C_m H_{2m-3} \cdot CO \cdot OH$	Propiolic (or linolic) series.
$C_m H_{2m-5} \cdot CO \cdot OH$	Linolenic series.

* *Annalen der Chemie*, pp. 223-283; also in abstract, *Journal Soc. Chem. Industry*, 1884, p. 448.

Two other families are more highly oxidised, being included in the general formula $C_m H_{2n} \left\{ \begin{array}{l} OH \\ CO \cdot OH \end{array} \right.$; according as $m = n$ or $= n + 1$ the following two families result :—

Formula of Acid.	Family.
$C_m H_{2m} \left\{ \begin{array}{l} OH. \\ CO \cdot OH. \end{array} \right.$	Oxyacetic (oxystearic or glycollic) series.
$C_m H_{2m-2} \left\{ \begin{array}{l} OH. \\ CO \cdot OH. \end{array} \right.$	Oxyacrylic (oxyoleic or ricinoleic) series.

In addition to these six leading families of monobasic acids, representatives of several others are obtainable by saponification from various essential oils and allied products; whilst by gentle oxidation processes or other reactions several different kinds of more oxidised monobasic acids are readily formed from the normal "fatty acids" derived from natural fixed oils, &c. Thus for example :—

Formula of Acid.	Family.	Examples and Sources.
$C_m H_{2m-7} \cdot CO \cdot OH$	Benzoic series	{ Benzoic and toluic acids, &c.; from gum benzoïn, balsam of Tolu, dragon's blood, storax, oil of bitter almonds, &c.
$C_m H_{2m-9} \cdot CO \cdot OH$	Cinnamic series	{ Cinnamic acid; from oil of cinnamon, cassia, storax, balsam of Tolu, &c.
$C_m H_{2m-8} \left\{ \begin{array}{l} OH \\ CO \cdot OH \end{array} \right.$	Oxybenzoic (salicylic) series	{ Salicylic acid; from gaul- theria oil, &c.
$C_m H_{2m-1} \left\{ \begin{array}{l} OH \\ OH \\ CO \cdot OH \end{array} \right.$	Glyceric (dioxystearic) series	{ Oxidation of oleic acid and isomerides and homologues thereof.
$C_m H_{2m-2} \left\{ \begin{array}{l} (OH)_3 \\ CO \cdot OH \end{array} \right.$	Erythroglucic (tri-oxystearic) series	{ $C_{18}H_{36}O_5$; from oxidation of ricinoleic acid and its iso- merides.
$C_m H_{2m-3} \left\{ \begin{array}{l} (OH)_4 \\ CO \cdot OH \end{array} \right.$	Tetroxystearic series	{ $C_{18}H_{36}O_6$ (sativic acid); from oxidation of linolic acid.
$C_m H_{2m-5} \left\{ \begin{array}{l} (OH)_6 \\ CO \cdot OH \end{array} \right.$	Hexoxystearic series	{ $C_{18}H_{36}O_8$ (linusic acid); from oxidation of linolenic acid.

ACETIC FAMILY OF FATTY ACIDS.

The following table denotes the leading acids of the acetic family (general formula $C_n H_{2n} O_2 = C_m H_{2m+1} \cdot CO \cdot OH$) derived from fixed oils, waxes, essential oils, and similar sources: in addition numerous isomeric modifications of many of the acids are known, obtained artificially by synthetic and other laboratory operations :—

Formula.	Name of Acid.	Boiling Point.	Melting Point.	Source.
CH ₂ O ₂ C ₂ H ₄ O ₂	Formic, Acetic,	101°C 118°	8°C 17°	Ants; nettles. Acetous fermentation; oil of cow parsnep, and various other essential oils.
C ₃ H ₆ O ₂	Propionic or Tritylic,	140°	...	Oxidation of propylic alcohol from fermented fusel oil.
C ₄ H ₈ O ₂	Normal Butyric, Isobutyric,	162° 153°	-3° ...	Cow's butter; perspiration; oil of cow parsnep. Oxidation of isobutylic alcohol from fusel oil; Roman chamomile oil.
C ₅ H ₁₀ O ₂	Valeric or Pen- toic,	175°-185°	...	Several isomerides known. Valerian root; Isovaleric acid from fat of <i>Delphinium Phocena</i> .
C ₆ H ₁₂ O ₂	Caproic or Hexoic,	200°	-9°	Isohexoic acid (isobutyl-acetic acid) from cow's butter and cokernut oil.
		205°	-1°·5	Normal hexoic acid, as octylic ether in oil of <i>Heracleum</i> .
C ₇ H ₁₄ O ₂	Enanthic or Heptoic,	222°	-10°·5	Normal acid by oxidation of enanthol from castor oil; wine fusel oil.
C ₈ H ₁₆ O ₂	Caprylic or Octoic,	238°	15°	Isoprimary acid from cokernut oil and butter; Limburg cheese.
C ₉ H ₁₈ O ₂	Pelargonic or Ennoic,	254°	13°	Normal acid from oil of <i>Pelargonium roseum</i> ; and oxidation of oil of rue and beetroot fusel oil.
C ₁₀ H ₂₀ O ₂	Capric or Decoic,	269°	30°	Butter; cokernut oil; grape fusel oil.
C ₁₁ H ₂₂ O ₂	Hendecic or Undecylic,	228° at 160 millims. pressure.	28°·5	Hydrogenation of Hendecenoic acid from distillation of castor oil.
		...	35°	Cocinic acid (?) in cokernut oil.
		...	Near 23°	Umbellulic acid (?) from chaulmoogra oil.
C ₁₂ H ₂₄ O ₂	Lauric or Dode- coic,	225° at 100 millims. pressure.	44°	Laurel butter (<i>Laurus nobilis</i>); Pichurim bean fat; cokernut oil; palm kernel oil.
C ₁₃ H ₂₆ O ₂	Tridecoic,	Supposed to be contained in cokernut oil; doubtful.
C ₁₄ H ₂₈ O ₂	Myristic,	250° at 100 millims. pressure.	54°	Nutmeg butter; cokernut oil; dika fat; croton oil; spermaceti.
C ₁₅ H ₃₀ O ₂	Pentadecoic,	...	55°	(?) Oil of <i>Jatropha curcas</i> .

Formula.	Name of Acid.	Boiling Point.	Melting Point.	Sources.
$C_{15}H_{30}O_2$	Pentadecic,	...	53°·5	Cetic acid (?) from spermaceti.
			53°	Benomargaric acid (?) from oil of Ben. Stillistearic acid (?) from <i>Stillingia sebifera</i> .
$C_{16}H_{32}O_2$	Palmitic,	271°·5 at 100 millims. pressure.	62°	Palm oil. One of the constituents of most animal fats. Spermaceti; beeswax; Japan wax.
$C_{17}H_{34}O_2$	Margaric,	...	60°	From cetyl cyanide; formerly supposed to be contained in certain fats.
	Daturic,	...	55°	From oil of <i>Datura Stramonium</i> .
$C_{18}H_{36}O_2$	Stearic,	291° at 100 millims. pressure.	69°·2	Tallow, lard, and most animal solid fats; Shea butter; Illipé fat.
$C_{19}H_{38}O_2$	Enneadecic,	...	66°	From stearyl cyanide (?) obtained along with artificial margaric acid.
$C_{20}H_{40}O_2$	Arachic (or Arachidic); Butic,	...	75°	Earthnut oil (<i>Arachis hypogea</i>); butter (?) (Heintz).
$C_{21}H_{42}O_2$	72°·5	Medullic acid (?) from beef marrow.
$C_{22}H_{44}O_2$	Benic or Benistearic,	...	76°	Oil of Ben; black mustard seed oil; rape oil.
$C_{23}H_{46}O_2$
$C_{24}H_{48}O_2$	Lignoceric,	...	81°	Earthnut oil; beechwood tar.
	Carnaubic,	...	72°·5	Carnauba wax.
	46°	Paraffinic acid (?) from paraffin wax and nitric acid.
$C_{25}H_{50}O_2$	Hyænic,	...	78°	Hyæna fat.
$C_{26}H_{52}O_2$	Geoceric acid (?) from distillation of brown coal.
$C_{27}H_{54}O_2$	Cerotic,	...	78°	Beeswax; Carnauba wax; Chinese wax.
$C_{28}H_{56}O_2$
$C_{29}H_{58}O_2$
$C_{30}H_{60}O_2$	Melissic,	...	88°	Oxidation of myricylic alcohol from beeswax.
$C_{31}H_{62}O_2$
$C_{64}H_{128}O_2$	Theobromic,	...	72°	Cacao butter.

The formulæ ascribed to several of the acids named in the preceding table can hardly be regarded as established with perfect

certainly; thus the *cocinic acid*, $C_{11}H_{22}O_2$, formerly supposed to be contained in cokernut oil, appears from later researches to be in all probability only a mixture of other acids of the series; and the same remark applies to the *tridecoic acid*, $C_{13}H_{26}O_2$, from the same source, which appears to be simply a mixture of lauric and myristic acids. Similarly, *cetic acid*, $C_{15}H_{30}O_2$, and the isomeric (?) *benomargaric* and *stillistearic* acids are very doubtful bodies; the last has been stated by later observers to be simply palmitic acid, and benomargaric acid to be a mixture of palmitic and myristic acids. The *margaric acid*, $C_{17}H_{34}O_2$, formerly regarded as present in animal fats, has been since shown to consist of a mixture of stearic and palmitic acids and more or less oleic acid.* Again, the compositions ascribed to *medullic acid*, $C_{21}H_{42}O_2$; *hyænic acid*, $C_{25}H_{50}O_2$; *geoceric acid*, $C_{26}H_{52}O_2$; and *theobromic acid*, $C_{64}H_{128}O_{27}$ † require confirmation as regards the individual character and purity of these substances. Of those acids where the carbon present lies between C_{10} and C_{27} , it is noticeable that those of most frequent and widely-spread occurrence, and of which the compositions are ascertained with certainty, always contain an even number of carbon atoms; so that it has been supposed by some chemists that acids containing an odd number of carbon atoms do not actually occur as glycerides amongst the natural oils and fats, and that the bodies supposed to possess such a composition are really either mixtures of glycerides with even numbers of carbon atoms, or substances rendered otherwise impure. *A priori*, however, there seems no reason for doubting the possibility of the existence in nature of glycerides of acids containing an odd number of carbon atoms.

In the case of butter fat, cokernut oil, and some few other substances, fatty acids of low molecular weight (*i.e.*, where n in the general formula $C_nH_{2n}O_2$ is of low value), are present to some notable extent; but, as a general rule, natural oils and fats rarely yield fatty acids of this description where n has a smaller value than 12. Inasmuch as the lower members of the acetic acid family are comparatively easily volatile (especially along with water vapour), whilst the higher ones are almost non-volatile with ordinary steam, this practically means that the fatty acids from most fats and oils *will not readily distil by the aid of moist steam*, whilst a certain proportion of more easily volatile acids is contained in the mixture of acids obtained from butter fat and cokernut oil, &c. This distinction is utilised in certain cases as a means of testing the quality of such substances

* The margarine or oleomargarine used as a butter substitute is essentially a mixture of the glycerides of stearic and palmitic acids with sufficient olein to give it its soft texture.

† Graf was unable to find any theobromic acid in Cacao butter (*Arch. Pharm.*, 1888, 26, p. 830).

as regards adulteration and admixture with cheaper forms of fatty matter (Reichert's test, *vide* Chap. VIII.)

The fatty acids of the acetic series differ considerably in their respective degrees of solubility in water; the lowest members—formic, acetic, propionic, and butyric acids—are miscible with water in all proportions; the highest members, including myristic acid and all above it, are quite insoluble in water; the intermediate acids exhibit a degree of solubility the greater the lower the molecular weight; thus caprylic acid dissolves in 400 parts of boiling water, and capric acid in about 1000 parts, both mostly separating out again on cooling; whilst lauric acid is almost insoluble in cold water, though sparingly dissolved by boiling water.

Alcohol, especially when warm, readily dissolves even the highest members of the series; inasmuch as the glycerides of these acids are, as a rule, almost insoluble in alcohol, this property affords a method of separating the free fatty acids contained in natural oils, &c., from the glycerides, the oil being simply agitated with alcohol and allowed to stand so as to separate the alcoholic solution of fatty acids from the unaffected glycerides. Alcohol containing only a minute quantity of a free fatty acid exhibits an acid reaction to phenolphthalein, and can accordingly be readily titrated volumetrically by means of a weak standard alkaline solution in presence of that indicator: on this also is based the general method of determining the amount of fatty acid salt formed on saponifying a glyceride or other compound ether by an alkali (Chap. VIII.) The highest acids of the series are not extremely soluble in cold alcohol, so that they are readily crystallisable from that menstrum.

The normal salts of acids of the acetic family are indicated by the general formula $C_nH_{2n+1}.CO.OM$, where M is a monad metal: acids salts of formula $C_nH_{2n-1}O_2M$, $C_nH_{2n}O_2$ can in some cases be produced—*e.g.*, sodium diacetate, $C_2H_3NaO_2$, $C_2H_4O_2$; potassium distearate, $C_{18}H_{35}KO_2$, $C_{18}H_{36}O_2$. Salts of this kind when dissolved in hot alcohol react acid with phenolphthalein, and behave toward alkaline solutions on titration with that indicator precisely as mixtures of the free acid and the neutral salt.

In certain cases the neutral alkali salts are partly hydrolysed by solution in water with formation of acid salt and caustic alkali; thus with neutral sodium stearate.

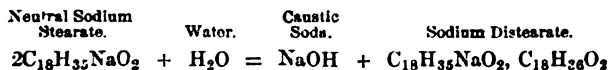

By adding common salt to the fluid, the latter compound and the unaltered neutral salt are thrown out of solution; on collec-

tion by filtration and solution in alcohol and titration an amount of acidity is registered precisely equivalent to the alkalinity of the watery fluid. On the occurrence of this phenomenon depends a good deal of the cleansing properties of soaps, the action being also observable with the alkali salts of oleic and ricinoleic acids to approximately the same extent as with those of palmitic and stearic acids (Chap. XXII.)

ACRYLIC (OLEIC) FAMILY OF FATTY ACIDS.

The total number of acids of general formula $C_nH_{2n-1}.CO.OH$ now known is somewhat considerable; as with the acetic family, only a comparatively small number of them are contained in natural fats, &c., and of these but few are of relatively low molecular weight so as to be readily volatile. The table on page 25 exhibits the more important acids of this class.

As in the case of the acetic family of acids, the existence of certain members mentioned in the table is not yet established with perfect certainty; thus *damaluric acid* is a substance the existence of which requires confirmation; and similarly with the *aldepalmitic acid* recently stated by Wanklyn to be a constituent of cow's butter.* The existence of hypogæic acid has been denied by Schön, who found the only acid of the acrylic series present in earthenut oil to be oleic acid. Similarly, moringic acid has been stated by more recent experimenters to be simply impure oleic acid; and the same kind of thing is said by Schädler to apply to doeglic acid this being regarded by him as simply impure physetoleic acid.

The unsaturated nature of the hydrocarbons from which this group of fatty acids are derived leads to their possession of some peculiar features; thus, when heated with fused alkali (caustic potash), there is a tendency to undergo a change indicated by the general equation:—

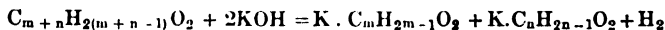

the potassium salts of *two acids of the acetic family* being formed along with free hydrogen. In virtue of this tendency, oleic acid, when thus treated, forms palmitic and acetic acids, a circumstance utilised in practical manufacture.

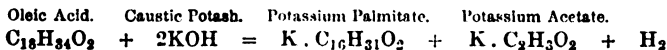

Again, inasmuch as the unsaturated hydrocarbons have a more or less marked tendency to combine directly with halogens (and

* *Journ. Soc. Chem. Ind.*, Feb. 1891, p. 89.

so pass into the series of substitution derivatives of the saturated hydrocarbons), the same tendency is shared by the fatty

Formula.	Name of Acid.	Boiling Point.	Melting Point.	Sources.
$C_3H_4O_2$	Acrylic,	140°C.	8°C.	Oxidation of acrolein from glycerol.
$C_4H_6O_2$	Crotonic,	185°	72°	From cyanide of allyl (derived from oil of mustard).
$C_5H_8O_2$	Angelic,	185°	45°	Angelica root. Sumbul root resin.
	Tiglic,	196°	64°	Oil of Chamomile. Croton oil.
$C_6H_{10}O_2$	Pyroterebic,	210°	...	Action of heat on terebic acid from oil of turpentine and nitric acid.
$C_7H_{12}O_2$	53°	Damaluric acid? (from cow's and horse's urine).
$C_8H_{14}O_2$	Octenoic,
$C_9H_{16}O_2$	Ennenic,	...	liquid.	Enanthol (from castor oil) and acetic anhydride.
	Phoronic,	...	169°	Oxidation of sodium camphor.
$C_{10}H_{18}O_2$	Decenoic,	242°-269°	10°-86°	Several isomeric modifications known; all of artificial origin.
$C_{11}H_{20}O_2$	Hendecenoic,	275°	24°-5	Castor oil distilled under diminished pressure.
	Petroleumic,	250°-260°	...	Contained in petroleum.
$C_{12}H_{22}O_2$	Dodecenoic,	...	liquid.	Artificial.
$C_{13}H_{24}O_2$	Tridecenoic,
$C_{14}H_{26}O_2$	Tetradecenoic,
$C_{15}H_{28}O_2$	Moringic,	...	0°	Oil of Ben.
	Cimicic,	...	44°	Fætid oil from <i>Raphigaster punctipennis</i> .
$C_{16}H_{30}O_2$	Physetoleic,	...	30°	Sperm oil.
	Hypogæic,	...	34°	Earthnut oil (<i>Arachis hypogæa</i>).
			50°	Aldepalmitic acid (?) from butter.
$C_{17}H_{32}O_2$	Heptadecenoic,
$C_{18}H_{34}O_2$	Oleic,	286° at 100 millims. pressure.	14°	Contained as glyceride in most animal fats and many vegetable oils.
	Isoleic,	...	44°-45°	Distillation of oxystearic acid.
	Stearidic,	...	35°	Action of water on silver bromostearate.
$C_{19}H_{36}O_2$	Doeglic,	...	A little above 0°	Oil from doegling (bottle-nose whale).
$C_{20}H_{38}O_2$
$C_{21}H_{40}O_2$
$C_{22}H_{42}O_2$	Erucic,	254°-5 at 10 millims. pressure.	34°	Colza, grape seed, and mustard oils.

acids derived from them; thus the hydrocarbon ethylene, as has long been known, combines directly with chlorine forming an oily fluid,* originally known as "Dutch liquid," the reaction being

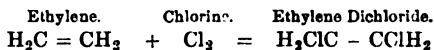

In the same kind of way, oleic acid and its congeners, being derivatives of ethylene of general formula $\text{R} \cdot \text{CH} = \text{CH} \cdot \text{S}$, will directly combine with bromine or iodine in parallel fashion, forming dibromo-, or diiodosubstitution derivatives of acids of the acetic family of form $\text{R} \cdot \text{CHBr} - \text{CHBr} \cdot \text{S}$; thus—

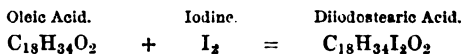

This reaction is utilised as a convenient method of distinguishing from one another acids derived respectively from saturated hydrocarbons, and from unsaturated hydrocarbons of the olefine series, the former not combining with halogens, and the latter uniting therewith in the proportion of one molecule of fatty acid to two atoms of halogen. Accordingly, the measurement of the quantity of iodine or bromine thus fixed ("iodine absorption equivalent," or "bromine absorption equivalent") often gives useful information as to the nature of the fatty acid or acids present; and the same remark equally applies to the glycerides themselves, which also combine with halogens in parallel fashion, *e.g.* :—

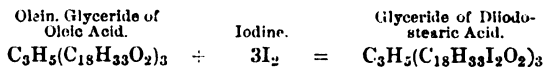

In just the same kind of way certain acids of the acrylic family can directly combine with nascent hydrogen produced under appropriate conditions, becoming thereby converted into acids of the acetic family, the general reaction expressing the change being—



Thus oleic acid forms stearic acid, when heated in a sealed tube with fuming hydriodic acid and phosphorus. By reversing the process, an acetic acid becomes transformed into an acrylic acid. In practice the direct removal of hydrogen after this fashion is difficult to accomplish; but in certain cases it may be effected by acting on the acid of the acetic family with chlorine or iodine or bromine, so as to produce a monochloro-, iodo-, or bromosubstitution derivative; by treating this with alkalis, &c.,

*Whence the old name *olefiant gas* for ethylene, signifying "oil making" gas.

the elements of HCl, HI, or HBr are eliminated, leaving an acid of the acrylic series.

Thus acrylic acid itself is formed from iodopropionic acid thus,

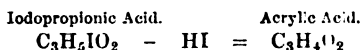

the elimination of the elements of hydriodic acid being brought about by treatment with sodium ethylate, lead oxide, or similar basic substances.

In other cases a dibromo- or dichlorosubstitution derivative of an acid of the acetic family is acted upon with zinc dust, or other substance having a strong tendency to combine with halogens; thus dibromopropionic acid and zinc dust form acrylic acid.

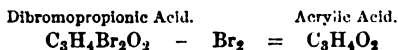

In this way the dibrominated and diiodised products obtained by adding Br_2 or I_2 to the higher acrylic acids can be made to reproduce the original acid. This reaction is utilised in the examination of oils, &c., containing the glycerides of unsaturated acids; bromine addition products are formed and separated from one another by crystallisation, &c., and then debrominated so as to reproduce the original acids, which can thus be indirectly separated from one another in a fashion usually impracticable with the actual acids themselves.

Acrylic acids, at any rate in certain cases, combine directly with sulphuric acid, forming saturated compound sulphuric acids analogous to ethylsulphuric acid (sulphovinic acid); thus—

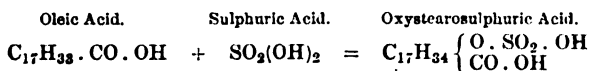

By the action of water, &c., on the compounds thus formed, hydrolysis is brought about, with the formation of sulphuric acid and an acid of the oxyacetic (glycollic) family; thus—

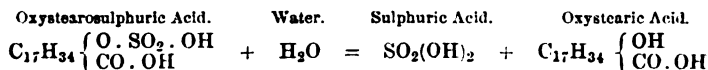

These reactions, especially the first, are utilised in the production of certain kinds of "Turkey red oils;" obviously the sum of the two changes is equivalent to the addition to an acrylic acid of the elements of water.

The dibromides of acids of the oleic series, when treated with silver hydroxide, &c., form silver bromide together with glyceric acids—*i.e.*, dioxy acids of the acetic series:—

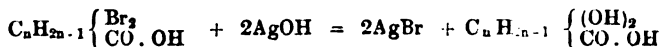

By the regulated action of caustic potash, they lose successively HBr and 2HBr, forming in the one case *bromoleic acid* or a homologue thereof, and in the other case a propiolic acid—

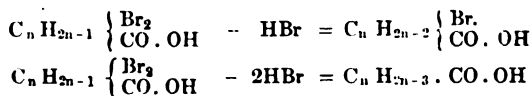

A remarkable property possessed by many acids of the oleic family is that contact with certain reagents, more especially nitrous acid, converts them into isomeric modifications of higher fusing and boiling points, so that acids liquid at the ordinary temperature become transferred into solids. This effect is also produced with the natural glycerides of these acids, forming a reaction largely utilised in testing the purity of certain oils (Chap. VII). Oleic acid, liquid at ordinary temperatures, thus becomes *elaidic acid*, melting at 45°, by contact with nitrous acid; and its glyceride, olein, fluid at 0°, is similarly converted into *elaidin*, melting at 32°; whence the term "Elaidin reaction" applied to this nitrous acid test. In similar fashion erucic acid, melting at 34°, is changed into *brassaidic* or *brassic* acid*, fusing at 60°; whilst parallel changes are undergone by hypogæic and phytetoleic acids.

Elaidic acid and the similarly altered other acids of this class can be distilled unchanged under diminished pressure, not being thereby converted back again into the original acids; for a given pressure the boiling point is always slightly higher than that of the original acid: thus Kraft and Noerdlinger † obtained the following numbers. (See Table, p. 29.)

The nature of the chemical change ensuing during the elaidin reaction is somewhat uncertain. By fusion with caustic potash both oleic and elaidic acids yield acetate and palmitate; on the other hand, by oxidation with alkaline permanganate they form two different dioxystearic acids, melting respectively at 136·5 (solidifying at 119°) and 99°-100° (solidifying at 85°-86°—Saytzeff). Similarly erucic and brassic (brassaidic) acids give rise to two different dioxybenic acids on oxidation, as well as different derivatives of other kinds.

* The term "brassic acid" (*brassica säure*) was originally applied to the acid, $C_{22}H_{42}O_2$, obtained from various species of *Brassica*, there being at that time some doubt whether "erucic acid" obtained from other analogous sources was or was not identical therewith. Later on the identity was established, and the term "brassaidic acid" (*brassidin säure*) was applied to the product of nitrous acid on erucic acid, to indicate its analogy with elaidic acid (Haussknecht, *Annalen der Chem. and Pharm.*, 1867, 143, p. 55). Of late years the term "brassic acid" has been mostly substituted in English chemical literature for "brassaidic acid" (e.g., Morley and Muir's *Dictionary of Chemistry*, vol. i., p. 631, article *Brassic Acid*).

† *Berichte der Deut. Chem. Ges.*, 1889, vol. xxii., p. 819.

Millimetres of Mercury.	Oleic Acid.	Elaidic Acid.
100	285.5—286	287.5—288
50	264	266
30	249.5	251.5
15	232.5	234
10	223	225
	Erucic Acid.	Brassic Acid.
30	281	282
15	264	265
10	254.5	256

From Erucic Acid.

	Melts at
Dioxybenic acid,	132°-133°
Dibromide of erucic acid,	42°-43°
Dichloride,	46°
Methylester from dichloride,	30°-5°

From Brassic Acid.

	Melts at
Isodioxybenic acid,	58°-99°
Dibromide of brassic acid,	54°
Dichloride,	65°
Methylester from dichloride,	42°-5°

According to recent researches* the isomerism of erucic and brassic acids is of the *stereochemical* order—i.e., the “structures” of the two bodies, when expressed in space of three dimensions, are not superposable; a difference only imperfectly expressible on a flat surface by the formulæ—

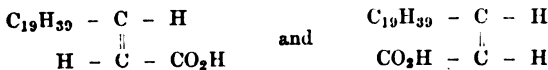

Isomerides of Oleic Acid.—Besides elaidic acid (formed from oleic acid by contact with nitrous acid), two other acids isomeric with oleic acid are known, viz., *isoleic* and *stearidic* acids; in addition, other isomerides of the anhydride character exist.

Isoleic acid is obtained by acting on oleic acid with sulphuric acid; combination takes place with the formation of *oxystearo-sulphuric* acid (probably two different modifications), thus—

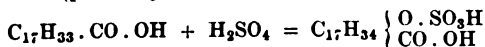

By hydrolysis the product forms *oxystearic acid* (again, probably more than one modification), which on distillation under diminished pressure becomes dehydrated, furnishing a mixture of ordinary oleic acid and a solid isomeride, *isoleic acid*.

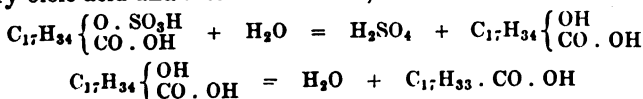

* A. Holt, *Berichte der Deutsch. Chem. Ges.*, 1891, vol. xxiv., 4120.

By converting the acids into zinc salts and heating with alcohol a solution is obtained from which zinc isooleate separates on cooling, the other zinc salt remaining in solution. The acid obtained from the pure zinc salt by decomposition by a mineral acid, crystallises from ether; it melts at 45°, but is not identical with elaidic acid which fuses at nearly the same temperature: like oleic and elaidic acids it forms acetate and palmitate on fusion with caustic potash; but the dibromide formed by combination with bromine when treated with silver hydroxide forms a dioxy-stearic acid melting at 77°-78° and solidifying at 65°-66°, the same substance being also formed by oxidising isooleic acid with alkaline permanganate; whereas the dioxystearic acids obtained by oxidising oleic and elaidic acids in the same way melt at 136°·5 and 99°-100°, and solidify at 119° and 85°-86° respectively.*

Isoleic acid combines with hydriodic acid, forming an iodo-stearic acid reducible to ordinary stearic acid by means of nascent hydrogen, and reconverted into isooleic acid by alcoholic potash. The dibromide of isooleic acid similarly reproduces isooleic acid on treatment with zinc and hydrochloric acid.

Stearidic Acid.—By the action of water on bromostearic acid (from bromination of stearic acid) Oudemans† obtained an acid isomeric with oleic acid, together with silver bromide. This product distilled unchanged: melting point 35°.

Two anhydrides of oxystearic acids are also known, isomeric with oleic acid; viz., *stearolactone*, γ -oxystearic "inner" anhydride (p. 39); and the body formed by the action of hydrochloric acid on α -oxystearic acid, regarded as—

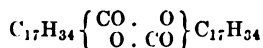

PROPIOLIC (LINOLIC) FAMILY OF FATTY ACIDS.

But few members of the family of acids of general formula $C_nH_{2n-3} \cdot CO \cdot OH$ have been as yet isolated from oils and fats, &c., the best known example being *linolic acid*, $C_{17}H_{31} \cdot CO \cdot OH$, contained in various drying oils, notably linseed oil; several other members, however, have been produced from acids of the oleic series by employing the method founded on the same principle as that by means of which oleic acids are obtainable from acids of the acetic acid series—viz., by conversion into a chloro- or bromoderivative of an acetic acid and removal of the elements of HCl or HBr by the action of a base. Thus oleic acid combined with Br_2 and the product treated with alcoholic potash furnishes *stearolic acid*—

* M. C. and A. Saytzeff, *J. prakt. Chem.*, 1888, 37, p. 269.

† *J. prakt. Chem.*, 89, p. 193.

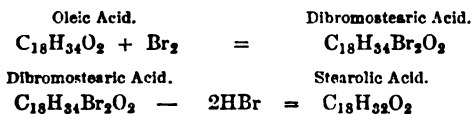

In similar fashion other homologues of stearolic acid (*c.g.*, *hendecolic*, *palmitolic*, and *benolic* acids) are obtainable from the corresponding homologues of oleic acid, the general reaction being—

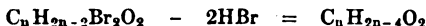

In certain cases propiolic acids may be directly obtained from acids of the acetic family by treatment with chlorine or bromine, so as to produce dichloro- or dibromoderivatives of formula $\text{C}_n\text{H}_{2n-2}\text{Br}_2\text{O}_2$, which are then acted upon with alkalis so as to remove the elements of 2HBr , in accordance with the above equation; the total change produced being therefore equivalent to the removal of H_4 . In this way, for instance, myristic acid, $\text{C}_{14}\text{H}_{28}\text{O}_2$, forms *myristolic acid*, $\text{C}_{14}\text{H}_{24}\text{O}_2$.

An analogous result is brought about with monochloro- or monobromoderivatives of acids of the acrylic series by similar treatment, the elements of HCl or HBr being removed, thus—

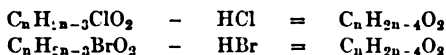

For instance, chlorocrotonic acid, $\text{C}_4\text{H}_5\text{ClO}_2$, gives rise by this treatment to *tetrollic acid*, $\text{C}_4\text{H}_4\text{O}_2$.

The table on p. 32 includes the chief acids of this series:—

Just as one molecule of an acrylic acid will combine with I_2 or Br_2 , so will one of a propiolic acid unite with Br_4 or I_4 , this action being substantially the reverse of that above described, where a dibromoacetic acid loses 2HBr and becomes a propiolic acid; this reaction is utilised in the practical testing of oils (Chap. VIII.) Conversely, by the action of nascent hydrogen, zinc dust, and similar dechlorinising agents, the tetrabrominated or tetraiodised bodies thus formed become again reduced to the original propiolic acids; thus linolic acid can be separated from accompanying acids (obtained by saponifying the mixture of glycerides contained in linseed oil, &c.) by combining with bromine, separating by crystallisation the tetrabrominated derivative, $\text{C}_{18}\text{H}_{32}\text{Br}_4\text{O}_2$ (melting at $114^\circ\text{--}115^\circ$), and reproducing linolic acid by removing the bromine.

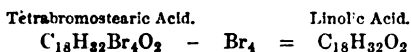

These propiolic acids that are formed by the bromine reaction above described (loss of 2HBr from dibromoderivatives of acids of the acetic family) possess the power of directly combining with oxygen (from suitable oxidising agents), forming saturated

Formula.	Name of Acid.	Melting Point.	Boiling Point.	Sources.
$C_3H_2O_2$	Propiolic,	Chloropropiolic acid, C_3HClO_2 , is formed by the action of potash on dichloracrylic acid, $C_2H_2Cl_2O_2$.
$C_4H_2O_2$	Tetrolic,	76·5°	203°	Chlorocrotonic acid and caustic potash.
$C_5H_6O_2$	Pentolic,
$C_6H_8O_2$	Sorbic,	Liquid at 15°	221°	Mountain ash berries.
$C_7H_{10}O_2$	Parasorbic, Benzoleic (Hydrobenzoic),	134·5°	...	Hydrogenation of benzoic acid.
$C_8H_{12}O_2$	Diallyl acetic,	Liquid	227°	Artificial.
$C_9H_{14}O_2$
$C_{10}H_{16}O_2$	Camphic,	Formed together with borneol by heating camphor with alcoholic soda.
	Campholenic,	...	Near 260°	Dibromcamphor and sodium amalgam.
$C_{11}H_{18}O_2$	Hendecolic (Undecolic or Hendecinoic),	59°·5	...	From undecylenic (hendecenoic) acid by bromine reaction.
$C_{12}H_{20}O_2$
$C_{13}H_{22}O_2$
$C_{14}H_{24}O_2$	Myristolic,	12°	...	From myristic acid by chlorination and action of alcoholic potash.
$C_{15}H_{26}O_2$
$C_{16}H_{28}O_2$	Palmitolic,	42°	...	From hypogæic acid by bromine reaction.
$C_{17}H_{30}O_2$	Elæomargaric,	48°	...	"Wood oil" from <i>Elæococca Vernicia</i> .
	Elæostearic,	71°	...	
$C_{18}H_{32}O_2$	Stearolic,	48°	...	From oleic acid by bromine reaction.
	Linolic,	Fluid	...	Linseed and other drying oils.
	Ricilinolic,	Fluid	...	Dehydration of ricinoleic acid.
	Tariric,	50°·5	...	Seeds of tariri (genus <i>Picramnia</i>).
$C_{19}H_{34}O_2$
$C_{20}H_{36}O_2$...	Fluid	...	(?) Higher homologue of linolic acid, supposed to be contained in some drying oils.
$C_{21}H_{38}O_2$
$C_{22}H_{40}O_2$	Behenolic (or Benolic),	57°·5	...	From erucic acid, by bromine reaction.

compounds by the addition of two oxygen atoms instead of four bromine atoms, thus—

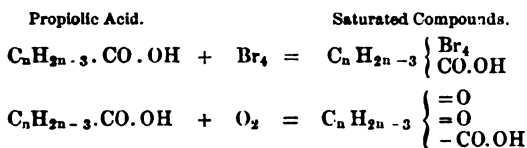

In this way stearolic acid, $C_{18}H_{32}O_2$, forms *stearoxylic* acid, $C_{18}H_{32}O_4$; and similarly with palmitolic and benolic acids. The general character of the action is indicated by the equation:

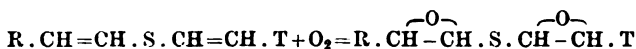

Linolic Acid.—The earlier researches on the acids derivable from the chief glycerides contained in linseed and other drying oils led to the conclusion that they were identical, and indicated by the formula $C_{16}H_{28}O_2$, and to this body the name *linoleic acid* was applied; but later experiments have shown conclusively that a considerably higher molecular weight is possessed by the acid obtained from linseed oil, and have rendered it not improbable that different homologous acids exist (related as myristic, palmitic, and stearic acids, for example), and that different drying oils are not always identical as regards the leading acid of this series present. Linolic acid was originally obtained by Schüler by saponifying linseed oil with caustic soda, salting out, dissolving in water, and precipitating with calcium chloride. The precipitate was treated with ether, whereby calcium linolate was dissolved out, leaving other substances undissolved; by agitating the ethereal solution with hydrochloric acid, and evaporating at a low temperature in an atmosphere of hydrogen, crude linolic acid was obtained. This was purified by treatment with alcoholic ammonia, precipitating as barium salt, and regenerating the acid as before. The analysis of the acid and its salts by Schüler, and subsequent investigators, led to the formula $C_{16}H_{28}O_2$.

On the other hand, the Koettstorfer values (Chap. VIII.) for linseed oil and other drying oils obtained by most of the later experimenters lead to the conclusion that the mean molecular weight of the fatty acids contained therein, is sensibly higher than 252, the value corresponding with $C_{16}H_{28}O_2$; the saponification equivalents for linseed, poppy, and hemp oils thus deduced mostly lie between 285 and 300, giving an average of 293 or thereabouts for the glycerides, and consequently of about 280 for the fatty acids thence derivable ($C_{18}H_{32}O_2 = 280$). Further, various later analyses of linolates and other derivatives corro-

borate this formula; whilst Peters* obtained *stearic acid* (of melting point 69°) by acting on linolic acid with strong hydriodic acid and phosphorus, so as to hydrogenise it.

Still higher molecular weights result from the observations of some chemists. Thus A. H. Allen † found that whilst the linolic acids isolated from several different samples of linseed oil possessed mean equivalent weights varying between 282 and 295, another specimen, prepared with great care in an atmosphere of coal-gas, gave 307·2 ($C_{20}H_{36}O_2 = 308$). Norton and Richardson ‡ found that linolic acid from linseed oil, when distilled at about 290° under a pressure of 89 mm., gave a colourless distillate, constituting about three-quarters of the whole; this was capable of being redistilled unchanged. It consisted of an acid of specific gravity ·9108 at $\frac{15^\circ}{4}$ giving numbers on analysis corresponding with the formula $C_{20}H_{36}O_2$; the vapour density was found to be 153, this formula representing 154. Moreover, on heating with hydriodic acid it did not form stearic acid, melting at 69°, as in the case of Peter's product, but an acid of considerably higher melting point—83° (arachic acid, $C_{20}H_{40}O_2$, melts at 75°).

Reformatsky§ on repeating the experiments of Schüler, obtained from linseed oil freshly expressed in the laboratory a crude linolic acid that did *not* distil unchanged at 292° under 100 mm. pressure. It contained a considerable amount of oleic acid, yielding dioxystearic acid on oxidation with permanganate; by heating with alcohol and gaseous hydrochloric acid, *ethyl linolate* was ultimately obtained, distilling at 270-275 under 180 mm. pressure; from this by saponification linolic acid was regenerated in a state of comparative purity; *e.g.*, giving the iodine number 172·65 to 180·3, that calculated being 181·4. When dissolved in glacial acetic acid the product thus prepared formed two compounds on addition of bromine—viz., a tetrabromide (addition product), $C_{18}H_{32}O_2Br_4$, as a viscid oil; and a crystallisable hexabrominated substance, regarded by him as a bromosubstitution derivative of the tetrabromide, $C_{18}H_{30}O_2Br_6$, melting at 177°-178° and solidifying at 175°. Oxidation with alkaline permanganate yielded tetroxystearic (*sativic*) acid and a little azelaic acid.

Whilst it appears exceedingly probable from the preceding results that more than one homologous acid of the series $C_nH_{2n}O_2$ exists in ordinary drying oils, it is more than doubtful whether any single substance in a state of purity was examined by

* *Monatsh. f. Chemie*, 1886, 7, p. 552.

† *Commercial Organic Analysis*, vol. ii., 1886, p. 117.

‡ *Berichte d. Deut. Chem. Ges.*, 1887, xx., p. 2735.

§ *Journ. Soc. Chem. Industry*, 1890, p. 744: from *J. prakt. Chem.*, 1890, 41, p. 529.

any of the various observers, inasmuch as purification by recrystallisation of a well marked crystalline derivative was not found readily practicable. On the other hand, Hazura and Grüssner obtained from hemp seed oil* a mixture of fatty acids which on solution in acetic acid and treatment with bromine gave more than one brominated product of crystallisable character, as well as noncrystalline ones. One of the crystallisable products was found to melt at 177°-178°, and to have the composition $C_{18}H_{30}O_2Br_6$; another melted at 114°-115°, and had the composition $C_{18}H_{32}O_2Br_4$; from this latter by the action of zinc and alcoholic hydrochloric acid the bromine was removed, producing linolic acid, $C_{18}H_{32}O_2$, free from admixture with other acids. It was found impracticable to brominate the bromine compound, $C_{18}H_{32}O_2Br_4$, so as to obtain from it any substitution derivative, $C_{18}H_{30}O_2Br_6$; whence it appears that the hexabrominated body, melting at 177°-178°, was *not* formed by the further substitutive action of bromine on the tetrabrominated addition product (as supposed by Reformatsky), but must have been produced by the direct combination of Br_6 with an acid, $C_{18}H_{30}O_2$, contained along with linolic acid, &c., in the original mixture; this acid, *linolenic acid*, is in fact easily reproduced from the hexabromide by treatment with zinc and alcoholic hydrochloric acid so as to remove the bromine (p. 27); conversely, it is again converted into the original hexabromide by direct combination with Br_6 .

The linolic acid thus obtained from the tetrabromide of fusing point 114°-115°, $C_{18}H_{32}O_2Br_4$, reproduced that substance by combination with bromine; and similarly combined with I_4 , but did not form a hexabrominated derivative; on oxidation with alkaline permanganate it formed a tetroxystearic acid, *sativic acid*, $C_{18}H_{36}O_6 = C_{17}H_{31} \left\{ \begin{array}{l} (OH)_4 \\ CO \cdot OH \end{array} \right.$, together with a little azelaic acid and other secondary products, but no linusic acid (p. 37). *Sativic acid* fuses at 170°;† on heating with hydriodic acid and phosphorus, it forms an iodised acid, reduced to *stearic acid* by means of zinc and hydrochloric acid; it dissolves in 1000 parts of *boiling* water, and is readily soluble in alcohol, but is insoluble in *cold* water and in ether; by acetylation it forms a tetracetyl derivative, $C_{17}H_{31} \left\{ \begin{array}{l} (O \cdot C_2H_5O)_4 \\ CO \cdot OH \end{array} \right.$; hence it obviously possesses the constitution of a quadruply hydroxylated stearic acid. On further oxidation it does not form linusic acid, but produces *azelaic acid*, $C_7H_{14}(CO \cdot OH)_2$.

Isomerides of Linolic Acid.—*Stearolic acid*, obtained by combination of oleic acid with Br_2 , and removing the elements of

* *Journal Soc. Chem. Industry*, 1888, p. 506: from *Monatsh. d. Chemie*, ix., p. 180.

† According to earlier observations, at 160°-162°.

2HBr from the product, fuses at 48°. By oxidation with alkaline permanganate, this forms *stearoxylic acid*, $C_{18}H_{32}O_4$, melting at 84°-86°, together with some *suberic acid*, $C_6H_{12}(CO.OH)_2$, produced by the further oxidation of the stearoxylic acid first formed (Hazura). Nitric acid also directly oxidises it to stearoxylic acid, with formation also of *azelaic acid*, $C_7H_{14}(CO.OH)_2$ (Overbeck), and of *pelargonic* (ennoic) acid (Limpach).

Tariric Acid.—A. Arnaud has recently described* an acid isomeric with linolic acid contained as triglyceride in the seeds of "tariri," a shrub common in Guatemala; it melts at 50°-5 C., and unites with bromine, forming a tetrabromide, $C_{18}H_{32}Br_4O_2$, melting at 125°.

Ricilinolic Acid.—This name may be conveniently applied to the acid obtained by Krafft, † by heating ricinoleic acid under diminished pressure (15 mm.), when an acid distilled, liquid at ordinary temperature, but solidifying on chilling; this boiled at 230° at 15 mm.; and gave numbers indicating that it was an isomeride of linolic acid, ‡ produced by the dehydration of ricinoleic acid, which might be expected *a priori* to take place, thus—

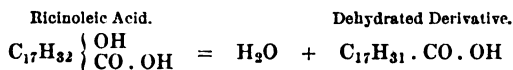

LINOLENIC FAMILY OF FATTY ACIDS.

The existence in drying oils of two isomeric acids of formula $C_nH_{2n-5}.CO.OH$ (where $n = 17$) in the form of glycerides has been rendered extremely probable, if not conclusively substantiated, by Hazura and various collaborateurs. When the fatty acids isolated from such oils—*e.g.*, hempseed or linseed oil—are dissolved in acetic acid, at least three different brominated compounds are obtainable by the addition of bromine—*viz.*, crystallisable *linolic acid tetrabromide*, $C_{18}H_{32}O_2Br_4$, melting at 114°-115°, and the crystallisable hexabromide, $C_{18}H_{30}O_2Br_6$, melting at 177°-178° above described (p. 35), together with a non-crystallisable liquid bromide, apparently containing an isomeric hexabromide, $C_{18}H_{30}O_2Br_6$. As already stated, the crystallisable hexabromide loses Br_6 by the action of zinc and alcoholic hydrochloric acid, forming *linolenic acid*, $C_{18}H_{30}O_2$, from which the same hexabromide can be reproduced by bromination; by oxidation with alkaline permanganate no sativic acid is pro-

* *Comptes rendus*, 114, p. 79.

† *Berichte d. Deut. Chem. Ges.*, 1888, p. 2730.

‡ By heating ricinoleic acid in vacuo, Norton and Richardson obtained an acid closely resembling linolic acid, regarded by them as $C_{20}H_{36}O_2$ (*Berichte d. Deut. Chem. Ges.*, 1887, xx. p. 2735).

duced, but, instead, *linusic acid*, a hexoxystearic acid, $C_{17}H_{29} \left\{ \begin{array}{l} (OH)_6 \\ CO.OH \end{array} \right.$. This last melts at 203° - 205° , and furnishes a hexacetyl derivative, $C_{17}H_{29} \left\{ \begin{array}{l} (O.C_6H_5O)_6 \\ CO.OH \end{array} \right.$. Hence the pre-existence of linolenic acid in the original mixture of acids, as the source of the crystallisable hexabromide, would seem to be pretty clearly demonstrated.

The existence of an isomeric modification of linolenic acid, *isolinolenic acid*, is inferred from the fact of a noncrystalline hexabromide being apparently produced by the addition of bromine to the original mixed acids, together with the circumstance that on oxidising the mixture by alkaline permanganate there are formed (in various relative proportions, according to the kind of drying oil operated on) not only *dioxystearic acid* (due to oleic acid contained), *sativic acid* (tetroxystearic acid, due to linolic acid, $C_{18}H_{32}(O_2)$), and *linusic acid* (due to linolenic acid), but also another hexahydroxylated stearic acid, *isolinusic acid*, isomeric with linusic acid; this melts at 173° - 175° , and furnishes a hexacetyl derivative, $C_{17}H_{29} \left\{ \begin{array}{l} (O.C_6H_5O)_6 \\ CO.OH \end{array} \right.$, resembling that obtained from linusic acid, but less soluble in ether.

OXYACETIC (GLYCOLLIC) FAMILY OF FATTY ACIDS.

The members of this family (general formula, $C_mH_{2m} \left\{ \begin{array}{l} OH \\ CO.OH \end{array} \right.$) hitherto recognised as normal constituents of fats, oils, waxes, &c., are but few in number. Carnauba wax has been found by Stürcke* to contain a small quantity of a substance simultaneously possessing the properties of an alcohol and an acid, indicated by the formula $C_{19}H_{38} \left\{ \begin{array}{l} CH_2.OH \\ CO.OH \end{array} \right.$; when this is heated with soda lime, it forms an acid of the oxalic family with evolution of hydrogen.

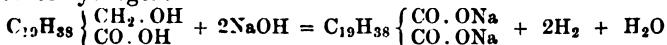

The essential oil of *Angelica Archangelica* contains (probably as some form of compound ether) an acid which appears to be *oxymyristic acid*,† $C_{13}H_{26} \left\{ \begin{array}{l} OH \\ CO.OH \end{array} \right.$, fusing at 51° , and yielding a *benzoyl oxymyristic acid* $C_{13}H_{26} \left\{ \begin{array}{l} O.C_6H_5O \\ CO.OH \end{array} \right.$, fusing at near

* *Annalen der Chemie.*, 223, p. 283; also *Journal Soc. Chem. Industry*, 1884, p. 448.

† R. Müller, *Berichte Deut. Chem. Ges.*, 1881, vol. xiv., p. 2476.

68°. An oxymyristic acid apparently identical with this is obtainable from myristic acid by brominating and treating the resulting monobromomyristic acid with caustic soda.

By similar processes palmitic acid yields *oxypalmitic acid* and stearic acid, *oxystearic acid*. Of this latter body, moreover, more than one isomeric modification is known; thus M. C. & A. Saytzeff found* that α -*oxystearic acid* is obtained when isoleic acid (m.p. 45°) is combined with hydriodic acid so as to form an iodostearic acid, and the product treated with silver hydroxide; while β -*oxystearic acid* is similarly obtained from ordinary oleic acid; the reaction in each case being expressed by the equations

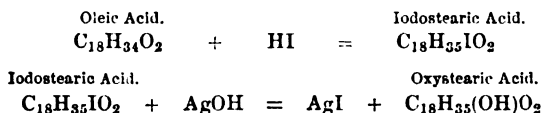

α -oxystearic acid melts at 80°-82° and distils unchanged; whilst β -oxystearic acid breaks up on heating into water and ordinary oleic acid—



The same two acids are also obtainable by treating isoleic acid with sulphuric acid, when combination takes place as the formation of two isomeric oxystearosulphuric acids, which by the hydrolytic action of water are decomposed into sulphuric acid and oxystearic acids, thus—

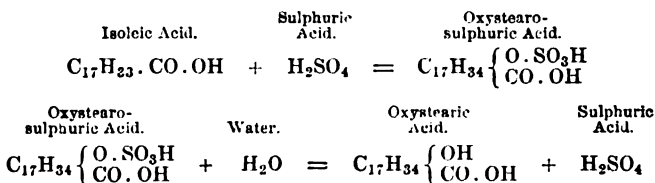

the two reactions jointly are consequently tantamount to the addition of water on to isoleic acid—

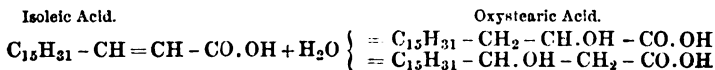

The α or the β acid thus results according as the hydroxyl group becomes added to the penultimate or antepenultimate carbon.

Geitel finds† that when ordinary oleic acid is thus treated

* *Jahresbericht*, 1888, p. 1916: from *Journal pr. Chemie*, [2] 37, p. 269.
† *Journal Soc. Chem. Industry*, 1888, p. 218; from *Journal f. prakt. Chemie*, [2] 37, p. 53.

with sulphuric acid, besides the α -oxystearic acids above described a γ -oxystearic acid, $C_{14}H_{20} - \text{CH} \cdot \text{OH} - \text{CH}_2 - \text{CH}_2 - \text{CO} \cdot \text{OH}$, is produced, which readily forms an "inner" anhydride, *stearo-*

lactone, $C_{14}H_{20} - \overbrace{\text{CH} - \text{CH}_2 - \text{CH}_2 - \text{CO}}^{\text{O}}$. This anhydride is produced whenever a salt of γ -oxystearic acid is decomposed by a mineral acid; if the acid solution be cautiously neutralised in the cold by an alkali, the stearolactone remains unaltered, and may be obtained by dissolving out with ether or benzoline, and thus separated from any other accompanying fatty acids set free by the mineral acid, but retained by the subsequent addition of alkali. When boiled with alcoholic potash, however, potassium γ -oxystearate is produced.



Processes for detecting and estimating stearolactone in mixture with free fatty acids, &c., are founded on these reactions. Stearolactone is readily soluble in alcohol, ether, and light petroleum spirit; it crystallises in needles melting at 51° ; it is formed in somewhat large quantity when oleic acid is heated with zinc chloride and the product treated with water (Benedikt), probably by reactions analogous to those taking place under the influence of sulphuric acid (*vide* Chap. VII.)

An anhydride isomeric with stearolactone is derived from α -oxystearic acid by the action of hydrochloric acid thereon (C. and A. Saytzeff) in accordance with the equation—

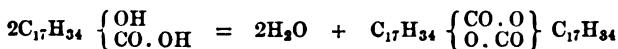

This substance is fluid at the ordinary temperature and does not solidify on chilling; it combines with neither bromine nor iodine (Hübl's reagent), but on heating with caustic potash becomes wholly converted into potassium oxystearate; on acidifying the product α -oxystearic acid is set free, and not an anhydride, as in the case of stearolactone.

OXYACRYLIC (RICINOLEIC) FAMILY OF FATTY ACIDS.

The acids of general formula $C_mH_{2m-2} \left\{ \begin{array}{l} \text{OH} \\ | \\ \text{CO} \cdot \text{OH} \end{array} \right.$ obtained by the saponification of fixed oils, &c., are not very numerous, *ricinoleic acid*, $C_{17}H_{32} \left\{ \begin{array}{l} \text{OH} \\ | \\ \text{CO} \cdot \text{OH} \end{array} \right.$, being the only one as yet known

with certainty; castor oil, and to a lesser extent some other oils, contain ricinolein, the glyceride of ricinoleic acid. To isolate the acid, castor oil is saponified with concentrated caustic potash solution, and the resulting soap decomposed by heating for a short time with hydrochloric acid; the separated acids are washed with water several times, and then cooled to 0° , or somewhat lower; the mass solidifies and is subjected to pressure, first gentle then stronger, so as to squeeze out liquid matters, the temperature being gradually raised to 10° - 12° . If any considerable quantity of unsaponified oil is mixed with the free fatty acids, their solidification by chilling is greatly hindered, a result also brought about by the presence of bye-products formed by the action of the air on the free fatty acids; wherefore the saponifying and decomposing operations, &c., should be conducted as rapidly as possible. Thus purified ricinoleic acid fuses at 16° - 17° , the phenomenon of superfusion being strongly shown by the liquid acid, which usually does not solidify again until considerably chilled.

When castor oil is heated, the ricinoleic acid present therein as glyceride breaks up into α -nanthol and hendecenoic acid, thus—

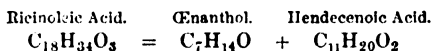

Free ricinoleic acid, however, when heated does not split up in this way at all, neither does it distil unchanged even under greatly diminished pressure—below 15° mm. An acid distillate passes over at about 250° , which on rectification furnishes an acid boiling at about 230° at 15 mm.; and giving numbers corresponding with the formula $\text{C}_{18}\text{H}_{32}\text{O}_2$ (p. 36), whence it would seem that water is thus split off from ricinoleic acid yielding a linolic acid isomeride. Hydriodic acid and phosphorus convert ricinoleic acid into stearic acid; heating with caustic potash forms a secondary decylic alcohol, $\text{C}_{10}\text{H}_{21}(\text{OH})$, and sebacic acid, $\text{C}_8\text{H}_{16}(\text{CO}\cdot\text{OH})_2$, from which reactions the structure would seem probable $\text{CH}_3 - (\text{CH}_2)_5 - \text{CH}\cdot\text{OH} - \text{CH} = \text{CH} - (\text{CH}_2)_8 - \text{CO}\cdot\text{OH}$. Alkaline permanganate oxidises ricinoleic acid to trioxystearic acid (Dieff and Reformatsky).

By the action of nitrous acid ricinoleic acid is converted into *ricinelauidic acid* melting at 52° - 53° ; on heating under diminished pressure, this is decomposed much more slowly than ricinoleic acid. Oxidation by means of nitric acid readily converts it into normal *heptolic acid*, whilst alkaline permanganate forms trioxystearic acid. According to Hazura and Grüssner, two different trioxystearic acids are formed when ricinoleic acid is thus oxidised, respectively melting at 140° - 142° (*trioxystearic acid*), and at 110° - 111° (*isotrioxystearic acid*); from which they infer the presence in castor oil of two isomeric acids

(*ricinoleic* and *isoricinoleic* acids respectively). Both of these trioxy acids form triacetyl derivatives, $C_{17}H_{32} \left\{ \begin{array}{l} (O \cdot C_2H_3O)_3 \\ CO \cdot OH \end{array} \right.$; and both are reducible to ordinary stearic acid by means of hydriodic acid; the latter is present to the extent of about twice as much as the former.

Isomerides of Ricinoleic Acid.—On heating barium ricinoleate Krafft obtained a residue from which an acid termed by him *ricinic acid* was isolated,* apparently isomeric with ricinoleic acid; this melted at 81° , and distilled unchanged at 250° - 252° under 15 mm. pressure; by oxidation it yielded normal heptoic acid.

Rapic Acid.—Reimer and Will have obtained from colza oil a liquid acid, $C_{18}H_{34}O_3$, differing considerably from ricinoleic acid, especially in not forming a solid elaidic acid with nitrous acid† and in not yielding sebacic acid on fusion with potash. This is isolated by means of the zinc salt which is soluble in ether, whereas zinc erucate is insoluble therein; by decomposing the recrystallised salt (melting at 78°) by tartaric acid, and well washing with water, rapic acid is obtained as a fluid mass, not solidifying even when considerably chilled.

Oxyoleic Acid.—When the dibromide of oleic acid (dibromostearic acid) is treated with silver hydroxide it forms oxyoleic acid, apparently in consequence of the removal of the elements of HBr, forming bromoleic acid, and the action thereon of silver hydroxide, thus—

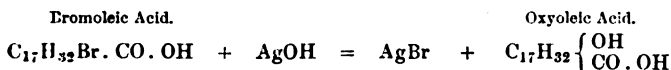

The same product results by first converting the dibromide into bromoleic acid by means of potash and then acting upon this with silver hydroxide (Overbeck). Oxyoleic acid is a thick liquid at ordinary temperatures but solidifies on chilling; by boiling with caustic potash it takes up water, forming a *dioxy-stearic acid*, melting at 126° .‡

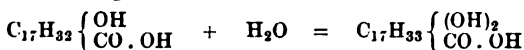

In similar fashion, *oxyhypogæic acid*, $C_{15}H_{28} \left\{ \begin{array}{l} OH \\ CO \cdot OH \end{array} \right.$, is formed when the dibromide of hypogæic acid is treated with silver hydroxide (Schröder); as with oleic dibromide, the action probably takes place in two stages, the elements of HBr being

* *Berichte d. Deut. Chem. Ges.*, 1888, vol. xxi., p. 2730.

† *Berichte d. Deut. Chem. Ges.*, 1887, vol. xx., p. 2385.

‡ Later experiments by Saytzeff indicate that this acid is identical with the dioxystearic acid melting at 136.5 , obtained by him by oxidation of oleic acid by alkaline permanganate (p. 30).

first removed, forming bromohypogæic acid, $C_{16}H_{29}BrO_2$, and this being then converted into the oxyacid, thus—

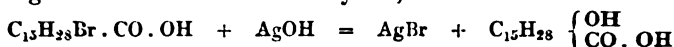

It melts at 34° , and by boiling with caustic potash solution takes up the elements of water forming *dioxy palmitic acid*,

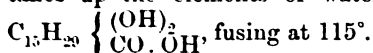

When oleic acid is heated to 200° and a stream of air blown through (as in the preparation of "blown oils," it absorbs oxygen and becomes largely converted into an *oxyoleic acid* (Benedikt and Ulzer). The relationships of the oxidised oleins and similar substances contained in blown oils to ricinoleic glyceride (castor oil) have not been fully studied, but apparently there is a considerable degree of similarity between them. The same remark applies to the oxidised acids formed when oils and fats are kept for long periods of time, so as to absorb oxygen largely from the air spontaneously. On the other hand, when drying oils are exposed to the air in thin films, so as to "dry" up to solid varnishes, they absorb oxygen; when the absorption attains its maximum, the increment in weight is tolerably close to that corresponding with the weight of iodine capable of being taken up by the original oil, whilst the capacity for absorbing iodine decreases *pari passu* with the oxidation. It would, therefore, seem that the tendency of atmospheric oxidation of drying oils is to produce less "unsaturated" oxidation products than the original substances; whence by analogy in the case of oleic glyceride, it would seem probable that saturated acids are formed thus, rather than unsaturated acids like oxyoleic acid. A product has been recently introduced into the market under the name of "oxyoleate," for use as a "Turkey red oil," obtained by the action of sulphuric acid on certain oils, and decomposition of the compound sulphuric acid formed by heat (*vide* Chap. VII.) The precise chemical nature of this substance does not seem to have been closely investigated as yet; presumably it chiefly consists of an oxystearic, rather than an oxyoleic acid, since by hydrolysis the former and not the latter results from the sulphuric acid compound of oleic acid (*supra*, p. 38).

Anhydrodioxy stearic Acid.—When dioxystearic acid (melting point 136.5°) is distilled under diminished pressure (100 to 180 mm.) it breaks up into water, and a monobasic acid, isomeric with ricinoleic acid, melting at $77-79^\circ$, and solidifying at $66-69^\circ$.* From its mode of formation this product is obviously indicated by the formula, $C_{17}H_{33} \begin{cases} =O \\ -CO.OH \end{cases}$, being a saturated compound, not containing alcoholiform hydroxyl like ricinoleic acid.

* A. Saytzeff, *J. prakt. Chem.* [2], vol. xxxiii., p. 300.

It is not improbable that the rapic acid above mentioned has an analogous constitution, since the low acetyl number possessed by colza oil renders it unlikely that any large quantity of a glyceride of a hydroxylated acid is present therein (Chap. VIII.)

POLYHYDROXYLATED STEARIC ACIDS.

A number of acids are known, related to stearic acid in that they are derived therefrom by the replacement of two or more hydrogen atoms by hydroxyl groups—i.e., by a further continuance of the action by means of which oxystearic acids may be regarded as derived from stearic acid. These polyhydroxylated derivatives are all expressed by the general formula,



When $n = 1$, some modification of oxystearic acid results; when $n = 2$, a dioxystearic acid (higher homologue of glyceric acid); similarly, when $n = 3, 4$, or 6 , trioxy-, tetroxy, and hexoxy-stearic acids respectively result.

The following table gives the principal sources and melting points of these acids, the usual mode of production being gentle oxidation of the acid serving as source with alkaline permanganate:—*

Name.	Formula.	Source.	Melting Point.	Solidifying Point.
Dioxystearic acid,	$C_{17}H_{33}(OH)_2.CO.OH$,	Oleic acid,	136°·5	119°-122°
Isodioxystearic acid,	Do.,	Elaidic acid,	99°-100°	85°-86°
Do.,	Do.,	Isoleic acid,	77°-78°	64°-66°
Trioxystearic acid,	$C_{17}H_{31}(OH)_3.CO.OH$,	Castor oil,	140°-142°	...
Isotrioxystearic acid,	Do.,	Do.,	110°-111°	...
β -isotrioxystearic acid,	Do.,	Ricinelaiddic acid,	114°-115°	...
Sativic acid (Tetroxystearic acid),	$C_{17}H_{29}(OH)_4.CO.OH$,	Linolic acid,	173°	...
Linusic acid (Hexoxystearic acid),	$C_{17}H_{25}(OH)_6.CO.OH$,	Linolenic acid,	203°-205°	...
Isolinusic acid (Isohexoxy-stearic acid),	Do.,	Hemp seed oil, &c., (supposed isolinolenic acid),	173°-175°	...

* A dioxystearic acid (melting point 136°) is also obtainable in small quantity by the action of silver hydroxide on the dibromide of oleic acid (p. 30); also by the hydration of oxyoleic acid (p. 41). Oxyhypogæic acid

A remarkable rule is uniformly followed in all cases where unsaturated fatty acids are thus oxidised—viz., that a *number of hydroxyl groups is always taken up sufficient to form a saturated polyoxy acid*.* Thus in the case of the oxystearic acids, unsaturated acids of form $C_{17}H_{33} \cdot CO : OH$ (oleic, isoleic, and elaidic acids), take up *two* hydroxyl groups forming three dif-

ferent dioxystearic acids, $C_{17}H_{33} \left\{ \begin{array}{l} (OH)_2 \\ CO \cdot OH \end{array} \right.$; similarly ricinoleic

and ricinelaidic acids of form $C_{17}H_{32} \left\{ \begin{array}{l} OH \\ CO \cdot OH \end{array} \right.$ take up 2 hy-

droxyl groups, producing two trioxystearic acids, $C_{17}H_{32} \left\{ \begin{array}{l} (OH)_3 \\ CO \cdot OH \end{array} \right.$

In the same way hendecenoic, hypogæic, and erucic acids take up 2 hydroxyl groups giving rise to dioxyhendecic, dioxypalmitic, and dioxybenic acids respectively. On the other hand, linolic acid, $C_{17}H_{31} \cdot CO \cdot OH$, takes up 4 hydroxyl groups, producing

sativic (tetroxystearic) acid, $C_{17}H_{31} \left\{ \begin{array}{l} (OH)_4 \\ CO \cdot OH \end{array} \right.$; whilst linolenic

acid, $C_{17}H_{29} \cdot CO \cdot OH$, takes up 6 groups, producing linusic (hexoxystearic) acid, $C_{17}H_{29} \left\{ \begin{array}{l} (OH)_6 \\ CO \cdot OH \end{array} \right.$

The above rule appears to be only a particular case of a considerably wider principle applying also to hydrocarbons and alcohols, &c., of unsaturated character, which may be put in the form of the following theorem:—

With substances containing the group - CH = CH - (or certain groups thence derived, - CR = CH, - and - CR = CS -, where R and S are monad alkyl radicles), the effect of oxidising agents of not too energetic a character is to cause the addition of two hydroxyl radicles so as to form the group - CH.OH - CH.OH - (or the derived group - CR.OH - CS.OH -), this action occurring twice over if two groups - CH = CH - are present, thrice over if three groups are present, and so on.

Thus Wagner has found* that olefines are readily transformed into glycols by means of potassium permanganate in virtue of this reaction; alcohols of unsaturated character (allylic series) similarly become glycerols; hydrocarbons containing the group - CH = CH - twice (*e.g.*, diallyl) become erythrols, and so on. Glycerol itself is thus obtainable from allylic alcohol.

(from dibromide of hypogæic acid) behaves similarly, forming a *dioxy-palmitic acid*, melting point 115°. A dioxypalmitic acid was obtained by Gröger (*inter alia*) by the direct oxidation of palmitic acid with alkaline permanganate. Two *dioxybenic acids* are known, respectively derived from the dibromides of erucic and brassic acids (p. 29), and melting at 132°-133° and 98°-99°.

* Hazura & Grüssner, *Journal Soc. Chem. Industry*, 1888, p. 506; from *Monatsh. Chem.*, vol. ix., p. 180.

† *Berichte. d. Deut. Chem. Ges.*, 1888, 21, pp. 1230 and 3343.

In all probability the first action taking place is the direct combination of oxygen in the same way as the combination of bromine or iodine, thereby forming a substance containing the group

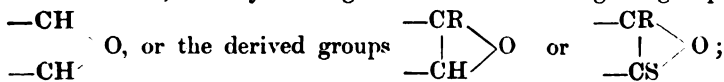

this product then assimilating water whilst nascent.

Thus, for example, oleic acid, $\text{C}_{17}\text{H}_{33} \cdot \text{CO} \cdot \text{OH}$, may be supposed to combine with oxygen, forming $\text{C}_{17}\text{H}_{33} \left\{ \begin{array}{l} =\text{O} \\ -\text{CO} \cdot \text{OH} \end{array} \right.$; by taking up water this immediately produces dioxystearic acid,

$\text{C}_{17}\text{H}_{33} \left\{ \begin{array}{l} \text{OH} \\ \text{OH} \\ \text{CO} \cdot \text{OH} \end{array} \right.$; whilst linolic acid, $\text{C}_{17}\text{H}_{31} \cdot \text{CO} \cdot \text{OH}$, similarly first forms $\text{C}_{17}\text{H}_{31} \left\{ \begin{array}{l} =\text{O} \\ =\text{O} \\ -\text{CO} \cdot \text{OH} \end{array} \right.$, which by taking up $2\text{H}_2\text{O}$

forms tetroxystearic acid (sativic acid), $\text{C}_{17}\text{H}_{31} \left\{ \begin{array}{l} \text{OH} \\ \text{OH} \\ \text{OH} \\ \text{OH} \\ \text{CO} \cdot \text{OH} \end{array} \right.$

In the case of the stearolic acid and its homologues obtained from acrylic acids by the bromine reaction (addition of Br_2 and removal of 2HBr , p. 31), the effect of oxidation stops short at the first stage, 2 atoms of oxygen being added on forming a saturated compound which does *not* take up water. Thus stearolic acid, $\text{C}_{17}\text{H}_{31} \cdot \text{CO} \cdot \text{OH}$, forms *stearoxylic acid*, $\text{C}_{17}\text{H}_{31} \left\{ \begin{array}{l} =\text{O} \\ =\text{O} \\ -\text{CO} \cdot \text{OH} \end{array} \right.$

melting at $84^\circ\text{-}86^\circ$, by the direct action of nitric acid (Overbeck),* or by means of alkaline permanganate (Hazura & Grüssner). Similarly palmitolic acid (from hypogæic dibromide), gives the

analogous *palmitoxylic acid*, $\text{C}_{15}\text{H}_{27} \left\{ \begin{array}{l} =\text{O} \\ =\text{O} \\ -\text{CO} \cdot \text{OH} \end{array} \right.$, melting at 67° (Schroëder); and benolic acid (from erucic dibromide) gives *ben-*

oxylic acid † melting at $90^\circ\text{-}91^\circ$, $\text{C}_{21}\text{H}_{39} \left\{ \begin{array}{l} =\text{O} \\ =\text{O} \\ -\text{CO} \cdot \text{OH} \end{array} \right.$ (Haussknecht).

* Overbeck (*Annalen. Chem. Pharm.*, 1866, 140, p.39) found that the stearoxylic acid thus prepared would not combine with bromine, and concluded that the 4 affinity units which in stearolic acid are capable of combining with Br_2 , are saturated by oxygen when stearolic acid is converted into stearoxylic acid.

† Termed "dioxibenolic acid" by its discoverer.

By the action of heat (distillation in vacuo) dioxystearic acid (melting at 136°), loses water forming an anhydro derivative still possessing the characters of a monobasic acid (Saytzeff); obviously thus—

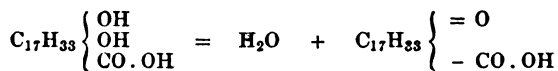

the reaction being the converse of the second stage in the hydroxylation of unsaturated acids as above.

§ 2. Physical Properties of Oils, Fats, Waxes, &c.

CHAPTER IV.

GENERAL PHYSICAL CHARACTERS.

PHYSICAL TEXTURE AND CONSISTENCY.

THE physical consistency of a fixed oil—butter, fat, or wax—depends entirely upon the temperature; when this is sufficiently raised all are fluid oils; but at lower temperatures, according to the nature of the substance, more or less complete solidification is brought about. In many cases, natural fixed oils, &c., are mixtures of different glycerides, &c., the melting points of which are different; accordingly, at temperatures somewhat below the melting point of the least fusible constituent, this more or less completely solidifies, whilst the other constituents remain liquid, thus giving rise to pastiness or buttery texture. Substances of practically uniform composition (*i.e.*, consisting essentially of only one kind of compound) generally exhibit a fairly sharply defined melting point when the temperature is sufficiently raised; but this is not the case with mixtures; accordingly, considerably different temperatures will be registered as the fusing points of such substances if different methods be employed, depending, for instance, in one case, upon the production of a considerable degree of softness only; in another, upon the complete liquefaction of all the constituents; and so on (*vide* p. 61, 63).

Even the most fluid oils possess to a greater or lesser extent the property of *viscosity*, or resistance to flow, due to the greater or lesser degree of cohesion between the constituent particles of the liquid. When the smooth surfaces of two solids are smeared or wetted with a viscous fluid and applied to one another, a varying degree of force will be requisite, according to circumstances, in order to enable one surface to glide over the other. The amount of force requisite in any given case largely depends on the viscosity of the fluid employed; to diminish this force is the

main object of *lubrication* in the case of machinery, and in consequence the determination of the relative lubricating powers of different materials (lubricating oils, &c.) is an important point in the valuation for such purposes of different fixed oils, mixtures of these and mineral oils, and such like substances employed for the purpose. It is found that the rate at which a given fluid flows through an orifice of standard dimensions is in many cases a fair measure of its lubricative powers; whence the determination is frequently made of the rate of efflux of lubricating oils, &c., as compared with that of a standard fluid (such as rape oil), similarly examined in the same apparatus at the same temperature, the value deduced being generally (but by no means correctly) spoken of as the *relative viscosity* of the fluid examined (*vide* Chap. v.)

Cohesion Figures.—When a drop of oil is allowed to fall gently on the surface of water in a basin or large plate, it often

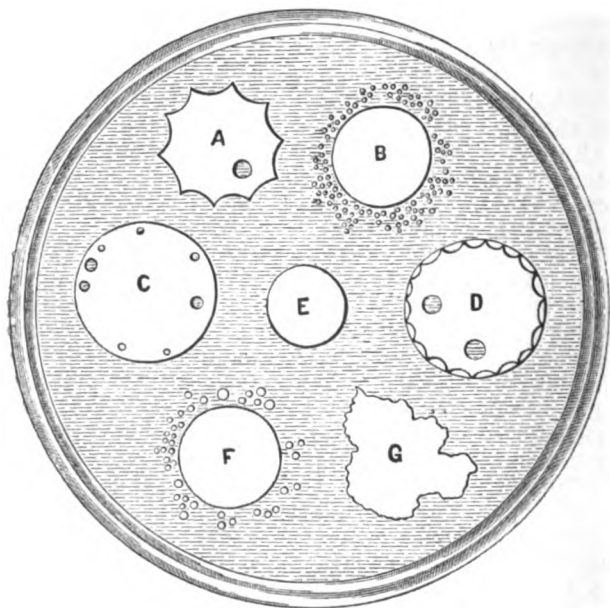

Fig. 1.

behaves in a characteristic way, usually first spreading out into a thin film and then retracting again. It has been suggested that the particular forms assumed by films of various kinds (*cohesion figures*) are sufficiently well defined and characteristic to be of service in the examination of oils with a view to

detecting adulteration; but as yet little success has attended experiments in this direction. Olive oil thus treated gives a fairly characteristic result, which is more or less modified by various admixtures, especially sesamé oil. Fig. 1 (Schädler) represents the different cohesion figures exhibited by colza oil (A, *Brassica rapa*; B, *Brassica napus*); poppy seed oil (C and D); sesamé oil (E); arachis oil (F); and olive oil (G).

Taste and Odour.—When in a state of absolute purity, fixed oils have usually little or no odour or taste; but as met with in commerce, in most cases traces of sapid or odorous matters accompany the oil, so as give a more or less characteristic flavour or smell thereto. Essential oils of the oxidised class, on the other hand, are frequently possessed of most powerful scent, although the hydrocarbons therein contained, when completely separated from all traces of oxidised matter (by heating with sodium or other similar means), are generally odourless or practically so. As regards the edible oils and fats, a considerable amount of their value depends on the delicacy and purity of the flavour; thus *genuine* olive oil is esteemed far more highly by connoisseurs than refined cotton seed oil, groundnut oil, and similar substances with which the ordinary commercial article is often largely intermixed, although, from the nutritive point of view, these latter are probably quite equal in value to the pure product of the olive. Similarly, the commercial value of butter is largely affected by its flavour and freedom from all trace of rancidity or rankness; and analogous remarks apply to lard. The difficulty of removing all matters communicating unpleasant odour or taste to many varieties of fatty or oily matter often prevents these being used for dietetic purposes to any considerable extent, at any rate by civilised nations; in the case of some materials—*e.g.*, cod liver oil—such removal is practically impossible without more or less interfering with the special characters and qualities of the substance. Palm oil has generally a peculiar smell, recalling that of violets, and for certain purposes the possession of this odour is valuable—*e.g.*, in the preparation of certain kinds of scented soaps. The development of “rancidity” in fixed oils on keeping is in most cases due to the presence in small quantity of mucilaginous or albuminous matters which undergo chemical changes (oxidation, or decomposition, &c.) in the course of time; accordingly, the purification and refining of crude oils, &c., for the purpose of removing these ingredients is often a highly important operation.

Colour.—Expressed vegetable fixed oils sometimes possess a greenish shade, due to the presence of chlorophyll; as a general rule, coldpressed oils of all kinds, prepared from fresh substances, are almost white; whilst oils subsequently expressed by the aid of heat, especially from materials that have been stored some time, are generally darker in tint, the hue varying from a

light straw yellow to a light or even dark brown. Palm butter usually contains a dark orange red colouring matter, different from chlorophyll; similar substances appear to be present in smaller quantity in many other oils, leading to the necessity for bleaching them for certain purposes. The refining processes, whereby mucilaginous extractive matters, &c., are removed, usually serve to lighten the colour also.

The addition of coloured vegetable expressed oils (containing chlorophyll, &c.) to animal oils, such as sperm oil, may sometimes be detected by means of the absorption spectroscopé* when such adulteration has been practised.

The phenomenon of *fluorescence* does not appear to be exhibited by refined vegetable or animal oils free from substances possessed of fluorescent properties (such as æsculin, occasionally found in horse-chestnut oil); on the other hand, products of destructive distillation (coaltar and rosin oils, &c.) often exhibit this peculiarity, so that admixtures of such hydrocarbons with more expensive vegetable and animal oils may sometimes be thus detected.

Action of Polarised Light.—The majority of the oils and fats in common use have so little action of a marked character on polarised light that little, if any, definite information of practical value is, as a rule, obtainable by means of such light; on the other hand, adulteration with strongly active hydrocarbons (such as some kinds of rosin oils) may sometimes be detected by means of the polariscope.

Bishop has obtained the following values for a length of 200 mm. of various oils in a Laurent polarimeter; the other figures annexed are from Schädler:—

		Bishop.	Schädler.
		Degrees.	Degrees.
Lævogyrate,	Linseed oil, . . .	- 0·3	- 0·2
	Nut oil, . . .	- 0·3	...
	Apricot oil,	- 0·2
	Arachis oil, . . .	- 0·4	- 0·1
	Sweet almond oil, . . .	- 0·7	- 0·2
	Colza oil, . . .	- 1·6 to - 2·1	- 0·3
Neutral, or nearly so,	Cotton seed oil,	0
	Poppy seed oil, . . .	0	+ 0·1
	Seal oil,	0
Dextrogyrate,	Olive oil, . . .	+ 0·6	+ 0·2
	Cod liver oil,	+ 0·5 to + 0·7
	Cold pressed sesamé oil, . . .	+ 3·1	} + 1·0 to + 1·1
	Hot " " . . .	+ 7·2	
	Castor oil,	

* A special form of absorption spectrum colorimeter for this sort of examination has been devised by T. L. Paterson; *vide Journ. Soc. Chem. Industry*, 1890, p. 36.

Peter finds most vegetable oils to be slightly lævogyrate, olive oil being an exception, so that admixtures of other oils may sometimes be detected by the rotation being left handed instead of right handed. Croton oil and castor oil, however, are comparatively powerfully dextrogyrate, giving values exceeding + 40°.

Refractive Index.—The differences in refractive power exhibited by different oils are in most cases hardly sufficiently marked to render this property of much value in discriminating one from the other, or in detecting admixtures, excepting in the case of a few oils and fats, such as olive oil and cow's butter; thus Strohmer gives the following values for the D line at 15°, and Abbé the annexed values at 20°, water being taken as 1.3330:—

	Strohmer.	Abbé.
Olive oil,	1.4698 to 1.4703	1.4690
Almond oil,	1.4810
Sesamé oil (new),	1.4748	...
„ nine years old,	1.4762	...
Walnut oil,	1.491
Cotton seed oil,	1.4732 to 1.4752	{ Crude, 1.4732 Refined, 1.4748
Rape and colza oil,	1.4720 to 1.4757	1.472 to 1.475
Beechnut oil,	1.5000
Cold drawn castor oil,	1.4795	} 1.490
Hot pressed „	1.4803	
Cold drawn linseed oil,	1.4835	1.4780
Poppy seed oil,	1.4783	1.4670
Cod liver oil,	1.4800 to 1.4852	1.4800
Whale oil,	1.483
Sperm oil,	1.470

From which it appears that olive oil has a sensibly lower refractive index than the others, whilst drying oils and castor oil exhibit the highest values. For the direct determination of the refractive index of oils and other substances, Abbé and Pulfrich have devised special “refractometers.”

Amagat and Jean* have also constructed an “oleorefractometer,” whereby the refractive power of a given oil is determined by differential comparison with a sample of genuine oil taken as standard, a positive reading denoting increased refractive index and *vice versâ*; the following comparative differential values have been obtained by de Bruijn and von Leent and by Jean in this way, from which results they infer that the refractive powers of

* *Comptes rendus*, 1889, 109, p. 616; see also *Journ. Soc. Chem. Industry*, 1890, pp. 113 and 218.

oils, when thus tested, are capable of giving more information as to admixture than is usually supposed. The oil to be examined should be previously shaken with alcohol to dissolve out free fatty acids; the standard of comparison was a sample of the purest olive oil obtainable:—

	de Bruijn and v. Leent.	Jean.
	Degrees.	Degrees.
Horse foot oil,	- 12
Sperm oil,	- 12
Neat's foot oil,	- 3
Sheep's trotter oil,	0
Olive oil,	0 to + 2	+ 1.5 to + 2
Almond oil,	+ 7	+ 6
Arachis oil,	+ 3 to + 4	+ 4 to + 5
Colza oil,	+ 15 to + 18	+ 16.5 to + 17.5
Sesamé oil,	+ 45	+ 17
Cotton seed oil,	+ 20
Maize oil,	+ 27
Poppy seed oil,	+ 30
Whale oil,	+ 30.5
Hemp seed oil,	+ 33
Castor oil,	+ 37 to + 46	+ 40
Linseed oil,	+ 49 to + 54	+ 53
Cod liver oil,	+ 42
Whale oil,	+ 30.5

Holde has obtained the following average results with this instrument,* the temperature of the testing-room being close to 20° throughout:—

	Limits of Index of Refraction.	Mean Index.
Refined rape oil,	1.4722 to 1.4736	1.4735
Crude rape oil,	1.4735 ,, 1.4760	1.4744
Olive oil,	1.4670 ,, 1.4705	1.4698
Mineral oil,	1.4776 ,, 1.4980	1.4923
Resin oil,	1.5274 ,, 1.5415	1.5344

The presence of rape oil in olive oil can thus be detected when any considerable amount of adulteration has been made.

In the case of butter, Jean claims that the oleorefractometer is capable of rendering useful service in the laboratory. Even if butter is not sufficiently constant in refractive power to enable a decision to be always arrived at as to the genuineness or other-

* *Journ. Soc. Chem. Industry*, 1891, p. 166.

wise of a given sample without further tests, still the oleo-refractometer indications at least enable a rough classification of a variety of samples to be made, viz., those undoubtedly spurious, those doubtful, and those probably genuine. The normal butter deviation is regarded by him as -29° to -31° , averaging -30° ; if higher values (32° - 36°) are observed, admixture with palm or cokernut oil is probable; slightly lower ones (25° - 29°) correspond with doubtful qualities; margarine and oleomargarine give much lower figures, 13° - 17° .^{*} Genuine butters have been found that give values materially below the normal deviation, but the cause of this is considered by Jean to be that the cows have been fed on oilcake, unaltered oil from which finds its way into the secreted milk in quantity large enough to affect the refraction, though too small to produce any marked effect either on the saponification equivalent, or the Reichert-Meissl-Wollny figure for volatile acids (Chap. VIII.)

Various British analysts also regard the oleo-refractometer as useful in preliminary butter examination, but other chemists consider its value in this respect to be overrated; thus de Bruijn and von Leent obtained very discordant results with Dutch butters, whilst H. O. G. Ellinger found † that genuine Danish butters gave deflections varying between 23° and 35° , according to the season of the year.

Electrical Conductivity.—In general, but little information is obtainable by examining the relative electrical conductivities of different oils. Olive oil, however, has a much lower conducting power than most other oils of ordinary occurrence, and hence, attempts to utilise this property as a means of detecting adulteration of olive oil have been made, notably by Palmieri, who has constructed a special instrument, or *diagonometer*, for the purpose; as yet, however, this method does not seem to have come into practical use to any considerable extent.

SOLUBILITY OF OILS, FATS, &c., IN VARIOUS SOLVENTS.

The immiscibility of "oil and water" is proverbial; but some few oils are known where the solubility in water, although far from perfect, is not entirely inconsiderable; thus the fusel oils of fermentation, and certain oxidised volatile essential oils, and products of distillation (*e.g.*, phenol), dissolve in water to the

^{*} *Journ. Soc. Chem. Industry*, 1892, p. 945; from *Monit. Scient.*, 1892, 6, p. 91.

† *The Analyst*, 1891, p. 197; from *Journ. f. prakt. Chemie*, [2] 44, p. 157.

extent of a few per cents. by weight at ordinary temperatures. As a general rule, however, fixed oils and hydrocarbons are, for practical purposes, entirely insoluble in pure water; in some few cases dilute alkaline solutions dissolve them somewhat more freely than pure water; in others the presence of acids slightly promotes solubility; but, as a rule, when neutral salts are present to any extent, their presence prevents the solution of the oil, &c.; so that on agitating an aqueous solution with solid common salt or with sodium sulphate, as the mineral matter goes into solution, the dissolved oil is more or less thrown out of solution. The same phenomenon is observed with the potash and soda salts of most of the fatty acids, so that when an aqueous solution of such salts (soaps) are treated with neutral saline matters, the organic salts are thrown out of solution; this property is largely utilised in the ordinary process of soap boiling.

Strong alcohol does not exert any great degree of solvent action in the cold on most fixed oils, solid fats, or waxes; whereas, many essential oils, whether hydrocarbons or of oxidised nature, are extremely freely soluble therein. Similarly, resins and free fatty acids are, generally speaking, moderately soluble in alcohol, especially when almost anhydrous and warm. Some few fixed oils, too, are exceptional as regards solubility in alcohol, more especially *castor oil* and *croton oil*, and to a lesser extent coker-nut oil, cow's butter, and linseed oil.

Girard finds that absolute alcohol at 15° dissolves the following proportions of various oils:—

Rape oil, }	1·5 to 2·0 per cent.
Colza oil, }	
Mustard seed oil,		2·7 ,,
Hazelnut oil,		3·3 ,,
Olive oil,		3·6 ,,
Almond oil,		3·9 ,,
Sesamé oil,		4·1 ,,
Apricot kernel oil,		4·3 ,,
Nut oil,		4·4 ,,
Beechnut oil,		4·4 ,,
Poppy seed oil,		4·7 ,,
Hemp seed oil,		5·3 ,,
Cotton seed oil,		6·4 ,,
Arachis oil,		6·6 ,,
Linseed oil,		7·0 ,,
Camelina oil,		7·8 ,,

Schädler gives the following Table representing the quantities of alcohol, of specific gravity '800, required to dissolve 1 part of oil or fat:—

	Cold.	Boiling.
	Parts.	Parts.
Almond oil,	60	15
Cacao butter,	4
Cotton seed oil,	75	...
Croton oil,	36	...
Camelina oil,	68	...
Cod liver oil,	45	6
Hemp oil,	30	Soluble in all proportions.
Japan wax,	3
Linseed oil,	40	5
Lard (hog's),	27
Madia oil,	30	6
Nut oil (walnut),	100	60 alcohol to 100 of oil.
Nutmeg oil,	4
Poppy seed,	25	6
Tallow (sheep),	45
Suet (ox tallow),	40
Whale oil (bottlenose),	1

As a general rule, fixed oils are very freely soluble in *carbon disulphide*, *chloroform*, *carbon tetrachloride*, *ether*, *benzene*, *light petroleum distillate* (mostly consisting of pentane and hexane with their homologues), and *oil of turpentine*; and on this property are based various methods of extracting oleaginous matters from natural and other sources. Castor oil, however, is almost insoluble in light petroleum spirit; whilst drying oils, when oxidised to some considerable extent, generally become either quite insoluble in these various solvents, or nearly so, the decrease in solubility usually being the more marked the greater the degree of oxidation. The action of nitrous acid on an oil (conversion into elaidin, Chap. VII.) usually diminishes the solubility of the oil thus affected.

Glacial acetic acid has been found by Valenta to be a convenient solvent for certain oils, &c., as a means of separation from one another. Thus, when equal volumes of acid and oil are intermixed, the oil being previously warmed, complete solution, even when cold, occurs with *castor oil*, *rosin oil*, and *olive kernel oil*, whilst *rape oil*, *mustard seed oil*, and *wild radish seed oil* are not completely dissolved even at the boiling point of the mixture. Most other oils give a clear fluid whilst hot, which on cooling becomes turbid, owing to the lesser solubility of the oil in the acetic acid at lower temperatures. It has been proposed* to make use of the temperature at which turbidity is thus brought about as a distinguishing test for oils of various kinds; but the figures obtained by different authorities who have repeated

* Valenta, *Dingler's Polytech. Journal*, 252, p. 296; also, *Journal of the Chemical Society*, 46, p. 1078.

Valenta's experiments, exhibit so much discrepancy as to render it very doubtful whether the results can be relied upon at all, as affording indications of adulteration or otherwise. Thus, the following values, amongst others, have been obtained by A. H. Allen* and G. H. Hurst:—†

Oil.	Valenta.	Allen.	Hurst.
	°C.	°C.	°C.
Olive (green),	85	...	} 28-76
„ (yellow),	111	...	
Almond,	110
Arachis,	112	87	72-92
Apricot kernel,	114	102	...
Neat's foot,	102	65-85
Sesamé,	107	87	...
Melon seed,	108
Cotton seed,	110	90	53-63
Niger seed,	49	...
Linseed,	57-74	36-41
Cod liver,	101	79	65
Menhaden,	64	...
Shark liver,	105	95
Porpoise,	40	...
Sperm,	98	85
Bottlenose,	102	74-84
Whale,	38-86	48-71
Palm,	23	83	Not turbid at 13
Laurelberry,	26-27	40	...
Nutmeg butter,	27	39	...
Cokernut,	40	7-5	Not turbid at 13
Palm kernel,	48	32	...
Bassia fat (Illipé),	64-5
Cacao butter,	105
Beef tallow,	95
Pressed tallow (M.P., 55-8),	114
Tallow oil (cold pressed),	47
Hog's lard,	96-5	...
Lard oil,	69-76
Butter fat,	61-5	...
Oleomargarine,	96-5	...

The practical value of the test, as shown by the above numbers, is obviously not very great; it is still further diminished by the circumstance that comparatively slight differences in the strength of the glacial acetic acid considerably influence the temperature of turbidity, as also does the presence or otherwise of free fatty acids; after an extended examination, Allen concludes that the results are too variable and indefinite to be of service in

* *Commercial Organic Analysis*, vol. ii., p. 26.

† *Journ. Soc. Chem. Industry*, 1887, p. 22.

discriminating the quality of oils ; an opinion also arrived at by G. H. Hurst, by Ellwood,* and by Thomson and Ballantyne,† the latter of whom obtained the following numbers, *inter alia*, with glacial acids of different strengths :—

Name of Oil.	Percentage of Free Acid present (calculated as Oleic Acid).	Temperature of Turbidity with Glacial Acetic Acid of		
		Sp. gr. 1054·2	Sp. gr. 1055·2.	Sp. gr. 1056·2.
		°C.	°C.	°C.
Olive (Syrian), . . .	23·88	42
„ (Gioja), . . .	9·42	65	80	91
Same sample freed from free acid, . . .	None.	87
Arachis oil (commercial),	6·20	76	96	112
„ (French refined),	·62	96	114	} Not completely dissolved.
Rape oil, . . .	4·54	105	} Not completely dissolved.	
„ . . .	2·43	110		„
Linseed oil (Baltic), . .	3·74	42	59	71
„ (River Plate), . . .	1·21	56
„ (East India), . . .	·79	57

In some few cases, however, the comparatively solubility in glacial acetic acid may afford a useful indication—*e.g.*, in detecting the presence of rape seed oil in linseed oil, and more especially of hydrocarbons in animal and vegetable saponifiable oils ; thus, mineral oils are but sparingly soluble in glacial acetic acid, so that on agitating with that solvent a mixture of mineral oil and other substances freely soluble in acetic acid, the latter are dissolved, leaving the former undissolved ; in this way the presence of rosin oil is easily detected in paraffin and petroleum distillates.

FUSING AND SOLIDIFYING POINTS.

It most unfortunately happens that several different thermometric scales are in use in different countries ; of these the Celsius or Centigrade scale is by far the most convenient, and is accordingly used almost exclusively for scientific purposes. In England, however, the highly inconvenient Fahrenheit scale is still largely in use for technical and general purposes ; whilst in some parts of the Continent the Réaumur scale is similarly employed. The following formula gives the means of translating the temperature expressed on any one of these systems to the

* *Pharmaceutical Journal*, 3, xvii., p. 519.

† *Journ. Soc. Chem. Industry*, 1901, x., p. 233.

corresponding value expressed on either of the others, **F** being the value on the Fahrenheit scale, **C** that on the Centigrade scale, and **R** that on the Réaumur scale :—

$$\frac{F - 32}{9} = \frac{C}{5} = \frac{R}{4}.$$

This formula is based on the system of construction of the three scales respectively ; the distance between the “ice melting point” (sometimes termed the “freezing point”) and the “steam point” (or “boiling point”—under normal atmospheric pressure) being divided into 180 degrees on the Fahrenheit scale,* 100 on the Centigrade, and 80 on the Réaumur scale ; so that the relative values of the degree in each scale respectively are— $\frac{1}{180}$: $\frac{1}{100}$: $\frac{1}{80}$; or $\frac{1}{9}$: $\frac{1}{5}$: $\frac{1}{4}$. The Réaumur and Centigrade scales, however, begin with the ice melting point as 0, so that the steam point is at 80° and 100° on the two scales respectively ; whilst the Fahrenheit zero is 32° F. below the ice melting point ; † whence that point is 32°, and the steam point 32 + 180 = 212°, on the Fahrenheit scale.

From the above formula are derived the following equations, whereby, when requisite, a Centigrade temperature may be translated into the corresponding Fahrenheit value, and so on :—

$$C = \frac{5}{9} (F - 32).$$

$$= \frac{5}{4} R.$$

$$F = \frac{9}{5} C + 32.$$

$$= \frac{9}{4} R + 32.$$

$$R = \frac{4}{5} C.$$

$$= \frac{4}{9} (F - 32).$$

* This particular number is said to have been selected on account of some hazy idea on the part of the inventor that the temperature-range between freezing and boiling of water had some connection with the number of degrees in a semicircle, or two right angles !

† Presumably because M. Fahrenheit noticed that the temperature of a mixture of snow and salt was 32 of his degrees below the freezing point of water, and concluded, for some unknown reason, that this must be the initial temperature, or absolute zero.

The following table affords a yet simpler means of effecting the translation :—

Centigrade.	Réaumur.	Fahrenheit.	Centigrade.	Réaumur.	Fahrenheit.	Centigrade.	Réaumur.	Fahrenheit.
- 40	- 32	- 40	+ 7	+ 5·6	+ 44·6	+ 54	+ 43·2	+ 129·2
- 39	- 31·2	- 38·2	+ 8	+ 6·4	+ 46·4	+ 55	+ 44	+ 131
- 38	- 30·4	- 36·4	+ 9	+ 7·2	+ 48·2	+ 56	+ 44·8	+ 132·8
- 37	- 29·6	- 34·6	+ 10	+ 8	+ 50	+ 57	+ 45·6	+ 134·6
- 36	- 28·8	- 32·8	+ 11	+ 8·8	+ 51·8	+ 58	+ 46·4	+ 136·4
- 35	- 28	- 31	+ 12	+ 9·6	+ 53·6	+ 59	+ 47·2	+ 138·2
- 34	- 27·2	- 29·2	+ 13	+ 10·4	+ 55·4	+ 60	+ 48	+ 140
- 33	- 26·4	- 27·4	+ 14	+ 11·2	+ 57·2	+ 61	+ 48·8	+ 141·8
- 32	- 25·6	- 25·6	+ 15	+ 12	+ 59	+ 62	+ 49·6	+ 143·6
- 31	- 24·8	- 23·8	+ 16	+ 12·8	+ 60·8	+ 63	+ 50·4	+ 145·4
- 30	- 24	- 22	+ 17	+ 13·6	+ 62·6	+ 64	+ 51·2	+ 147·2
- 29	- 23·2	- 20·2	+ 18	+ 14·4	+ 64·4	+ 65	+ 52	+ 149
- 28	- 22·4	- 18·4	+ 19	+ 15·2	+ 66·2	+ 66	+ 52·8	+ 150·8
- 27	- 21·6	- 16·6	+ 20	+ 16	+ 68	+ 67	+ 53·6	+ 152·6
- 26	- 20·8	- 14·8	+ 21	+ 16·8	+ 69·8	+ 68	+ 54·4	+ 154·4
- 25	- 20	- 13	+ 22	+ 17·6	+ 71·6	+ 69	+ 55·2	+ 156·2
- 24	- 19·2	- 11·2	+ 23	+ 18·4	+ 73·4	+ 70	+ 56	+ 158
- 23	- 18·4	- 9·4	+ 24	+ 19·2	+ 75·2	+ 71	+ 56·8	+ 159·8
- 22	- 17·6	- 7·6	+ 25	+ 20	+ 77	+ 72	+ 57·6	+ 161·6
- 21	- 16·8	- 5·8	+ 26	+ 20·8	+ 78·8	+ 73	+ 58·4	+ 163·4
- 20	- 16	- 4	+ 27	+ 21·6	+ 80·6	+ 74	+ 59·2	+ 165·2
- 19	- 15·2	- 2·2	+ 28	+ 22·4	+ 82·4	+ 75	+ 60	+ 167
- 18	- 14·4	- 0·4	+ 29	+ 23·2	+ 84·2	+ 76	+ 60·8	+ 168·8
- 17	- 13·6	+ 1·4	+ 30	+ 24	+ 86	+ 77	+ 61·6	+ 170·6
- 16	- 12·8	+ 3·2	+ 31	+ 24·8	+ 87·8	+ 78	+ 62·4	+ 172·4
- 15	- 12	+ 5	+ 32	+ 25·6	+ 89·6	+ 79	+ 63·2	+ 174·2
- 14	- 11·2	+ 6·8	+ 33	+ 26·4	+ 91·4	+ 80	+ 64	+ 176
- 13	- 10·4	+ 8·6	+ 34	+ 27·2	+ 93·2	+ 81	+ 64·8	+ 177·8
- 12	- 9·6	+ 10·4	+ 35	+ 28	+ 95	+ 82	+ 65·6	+ 179·6
- 11	- 8·8	+ 12·2	+ 36	+ 28·8	+ 96·8	+ 83	+ 66·4	+ 181·4
- 10	- 8	+ 14	+ 37	+ 29·6	+ 98·6	+ 84	+ 67·2	+ 183·2
- 9	- 7·2	+ 15·8	+ 38	+ 30·4	+ 100·4	+ 85	+ 68	+ 185
- 8	- 6·4	+ 17·6	+ 39	+ 31·2	+ 102·2	+ 86	+ 68·8	+ 186·8
- 7	- 5·6	+ 19·4	+ 40	+ 32	+ 104	+ 87	+ 69·6	+ 188·6
- 6	- 4·8	+ 21·2	+ 41	+ 32·8	+ 105·8	+ 88	+ 70·4	+ 190·4
- 5	- 4	+ 23	+ 42	+ 33·6	+ 107·6	+ 89	+ 71·2	+ 192·2
- 4	- 3·2	+ 24·8	+ 43	+ 34·4	+ 109·4	+ 90	+ 72	+ 194
- 3	- 2·4	+ 26·6	+ 44	+ 35·2	+ 111·2	+ 91	+ 72·8	+ 195·8
- 2	- 1·6	+ 28·4	+ 45	+ 36	+ 113	+ 92	+ 73·6	+ 197·6
- 1	- 0·8	+ 30·2	+ 46	+ 36·8	+ 114·8	+ 93	+ 74·4	+ 199·4
0	0	+ 32	+ 47	+ 37·6	+ 116·6	+ 94	+ 75·2	+ 201·2
+ 1	+ 0·8	+ 33·8	+ 48	+ 38·4	+ 118·4	+ 95	+ 76	+ 203
+ 2	+ 1·6	+ 35·6	+ 49	+ 39·2	+ 120·2	+ 96	+ 76·8	+ 204·8
+ 3	+ 2·4	+ 37·4	+ 50	+ 40	+ 122	+ 97	+ 77·6	+ 206·6
+ 4	+ 3·2	+ 39·2	+ 51	+ 40·8	+ 123·8	+ 98	+ 78·4	+ 208·4
+ 5	+ 4	+ 41	+ 52	+ 41·6	+ 125·6	+ 99	+ 79·2	+ 210·2
+ 6	+ 4·8	+ 42·8	+ 53	+ 42·4	+ 127·4	+ 100	+ 80	+ 212

In the following pages, whenever a temperature is expressed as a number without the scale used being mentioned, it is always to be understood that the *Centigrade value* is intended.

Determination of Fusing and Solidifying Points.—Inasmuch as most natural oils and fats, &c., are not chemically pure single substances, but generally consist of one or more main ingredients with smaller quantities of other allied bodies, as a general rule no sharply defined temperature exists characteristic of the fusing or solidifying point of any given variety, although in many cases pure unadulterated specimens, even though of widely various origin, do not differ largely in these respects. For the same reason, the point at which incipient solidification on chilling first becomes manifest, often differs considerably from the temperature at which the mass, when once rendered solid by cold, exhibits incipient fusion on gradual heating. Further, a given substance, if heated considerably above its melting point and then cooled quickly so as to solidify it again, will often melt for the second time at a temperature materially different from that at which it first fused, although the normal melting point is more or less regained on standing for some time; accordingly, if the fusing point of a solid fat that has been once melted is to be determined, a sufficient time must be allowed to elapse to enable the normal physical structure to be re-assumed. In practice, it is generally necessary first to melt the substance and then clarify it by subsidence, or, better, by filtration through dry paper, in order to remove suspended matters and, more particularly, water; so that the purified material, after cooling and solidification, must be allowed to stand some time (at least an hour or two, but preferably a much longer period, say till the next day) before further examination.

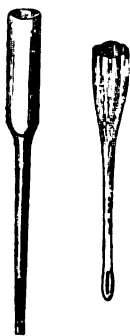

Fig. 2.

In order to determine the fusing point of a solidified specimen, several different methods are in use, the results of which are not always comparable with one another; so that, if an accurate comparison of two substances is requisite, it is indispensable that *both must be examined by the same process, side by side*. One of the most frequently used methods consists in preparing a capillary tube by drawing out in a flame a short piece of quill tubing (Fig. 2); the fine end is sealed up, and when cool, the solid to be examined is cut into very fine fragments or pulverised, and a little dropped in and shaken down into the capillary tube. This is then bound by wire, string, or an india-rubber ring to the stem of a thermometer (Fig. 3), so that the centre of the bulb is about level with the substance; the whole is then placed in a small vessel of water (or, for higher temperatures,

melted paraffin wax) which is very slowly raised in temperature, either by means of a small flame underneath (Fig. 4), or, preferably, by placing it inside a much larger similar vessel; a large flask with the neck cut off and a small beaker answer well (Fig. 5). Olberg employs for this purpose the circulatory arrangement shown in Fig. 6; this is filled with water or oil, the heat being applied at the base of A.

If circumstances permit, two such capillary tubes (or more) should be provided, one being used to obtain a first rough



Fig. 3.

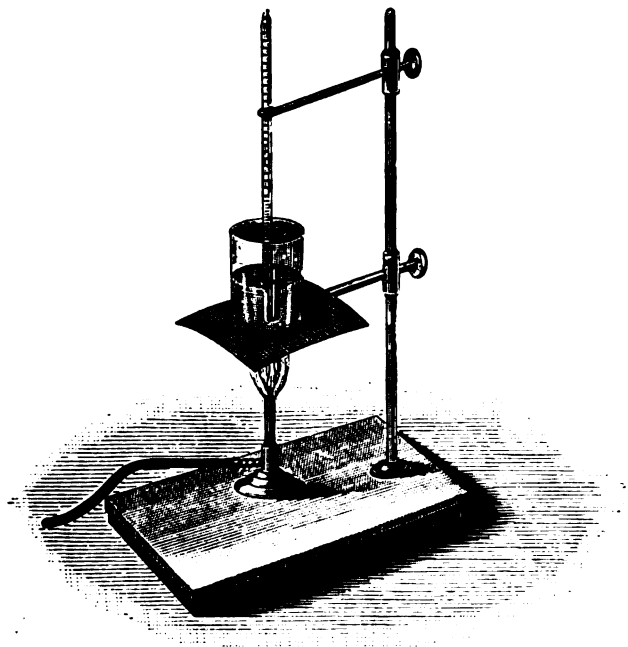

Fig. 4.

approximation to the melting point, and the others used subsequently to obtain a nearer result, the bath being previously slightly cooled below the first approximate value, and then very slowly heated again, so that several minutes are requisite to produce a rise in temperature of 2° or 3° C. The thermometer and attached tube are used as a stirrer during this heating, and the temperature noted when the fragments first show signs of melting. Frequently this temperature (*softening point*) is measurably below that requisite to cause the fragments to liquefy entirely, and run down to the bottom of the capillary tube as a clear fluid (*temperature of complete fusion*).

Instead of a capillary tube sealed up at the end, one bent into a U or V shape may be employed, the solid particles being shaken down to the bend or angle. Bensemann* modifies the tube by drawing it out as represented in Fig. 7. A drop or two

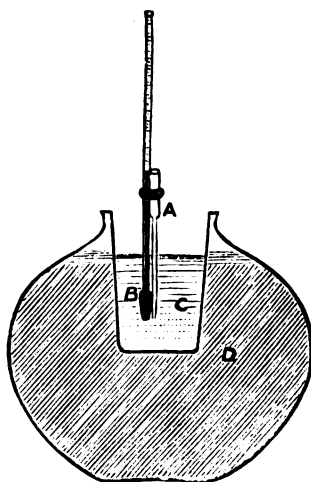

Fig. 5.

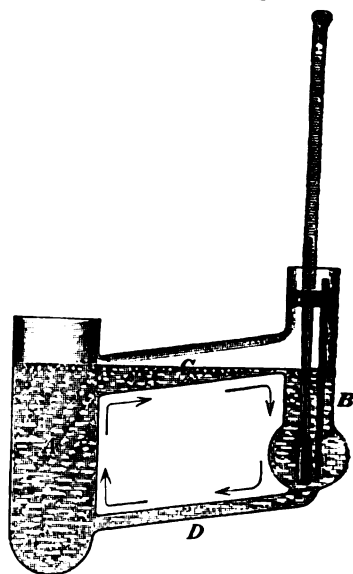

Fig. 6.

of melted substance is introduced into the bulbous portion of the tube, A, and fused as indicated by *a*. After standing for a sufficient time, the tube is placed in water, the temperature of which is very slowly raised; the temperature of incipient liquefaction is readily observed when the material softens and begins to run; at a little higher temperature it all runs down as indicated by *b*; when the turbid liquid becomes completely clear, the temperature of complete fusion is attained.

Another method of operating consists in drawing out the capillary tube as before, but *without* sealing up the narrow end; this end is then dipped into the molten substance to be examined and withdrawn, so that half an inch or so of the capillary tube is filled up with the material. After standing at least an hour, but preferably till next day, the capillary tube is attached to the thermometer and placed in the bath as before; when the temperature rises to the softening point so as to produce incipient fusion, the plug of solid matter in the capillary tube becomes softened where it touches the glass, and is consequently

* *Journ. Soc. Chem. Industry*, 1885, iv., p. 535; from *Rep. Anal. Chem.*, 11, p. 165.

forced upwards by the hydrostatic pressure of the fluid in the bath; when this occurs the temperature is noted. The former process, as a rule, is to be preferred, not only because it gives both the softening point and the temperature of complete liquefaction, but also, because by withdrawing the source of heat and allowing the completely fluid mass to cool slowly, the temperature at which re-solidification occurs can be more or less accurately determined. With some kinds of mixed substances, the sealed-up capillary tube process enables three different temperatures to be ascertained, viz. :—First, the temperature of incipient fusion when the most fusible constituent commences to melt; second, a temperature when this constituent has become so far melted that

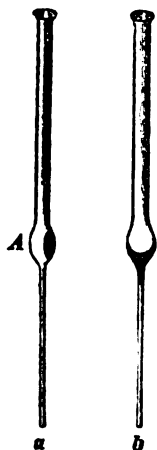

Fig. 7.

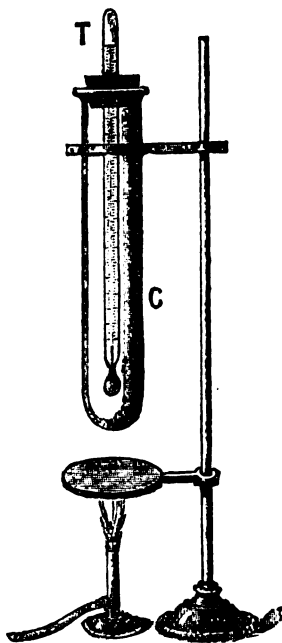

Fig. 8.

the solid fragments run down visibly; and third, a still higher temperature *when the whole mass becomes clear and limpid*, showing that the whole of the less fusible constituents have also become completely melted. With certain mixtures of free fatty acids, &c., the difference between the lowest and highest fusion temperatures thus determined may amount to upwards of 5° C.

A convenient method of determining the softening point in certain cases consists in dipping the bulb of the thermometer into the melted material to be examined, and causing a small light

glass bulb or float to adhere to the thermometer, cemented thereto by the substance as it solidifies. After waiting a sufficient time to enable the mass to attain its normal physical structure, the thermometer and bulb are placed in a bath, which is gradually heated; when the temperature attains the softening point, the float becomes detached and rises up in the fluid. Instead of a float, a thick coating of the substance itself may be applied to the thermometer by dipping the latter in the just-melted substance for an instant, taking out again until the adherent film has solidified, and repeating the operation two or three times so as finally to obtain a sufficiently thick coating. Fig. 8 represents Pohl's form of bath for the purpose, consisting of a wide test-tube, C, through the cork in the mouth of which passes the thermometer, T, the heat being applied by means of a small flame impinging on a flat metal disc, supported a little distance below the test-tube, so as to furnish an ascending current of warm air. Obviously a vessel of warm water may be substituted for the disc and flame. A modification of this plan has been suggested by Messrs. Cross and Bevan,* where a thin

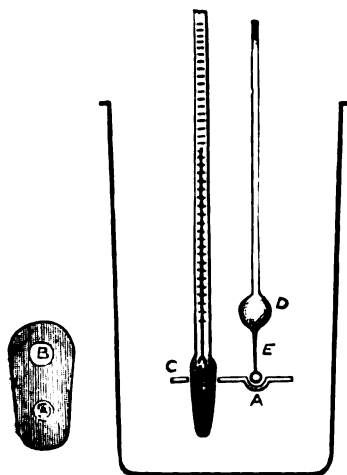

Fig. 9.

piece of sheet iron (ferrotype plate) is cut into the shape shown in Fig. 9, about $\frac{3}{4}$ inch long and $\frac{3}{8}$ or $\frac{1}{2}$ inch across; at A the plate is hammered so as to form a minute saucer or depression, and at B a hole is cut of such size as to allow the plate to fit on to the bulb (conical) of a thermometer. The float is made by blowing a bulb on the end of a thin piece of tubing, and fixing a bit of platinum wire therein, bent into an L shape. A drop of melted substance is put in the saucer, and the end of the wire dipped therein, the stem being supported in a vertical position until the substance solidifies, and so holds it firmly. The thermometer and float are

placed in a bath of water, &c. (preferably mercury), and when the temperature rises to the softening point, the float becomes detached and rises to the surface.

In many cases the temperatures of incipient fusion and of complete liquefaction may be easily determined by placing small fragments or pinches of powder of the substance examined on the

* *Journal of the Chemical Society*, vol. xli. (1882), p. 111.

surface of a bowl of perfectly clean mercury, the temperature of which is gradually raised, a thermometer being placed therein. When complete fusion is effected, the substance becomes a minute drop of clear fluid, which usually spreads out film-wise over the surface of the mercury. An ingenious modification of this method has been proposed by J. Læwe,* where the substance is first applied to the end of a platinum wire (by dipping into the just-fused substance), so as to cover it completely; the coated wire is then supported by means of an insulating holder of glass, just below the surface of the mercury, and connected with one pole of a small galvanic cell, whilst the mercury is connected with the other pole. As long as the substance is unmelted no contact takes place between the platinum wire and mercury; but as soon as fusion takes place contact is brought about, and an electric bell included in the circuit is made to ring. Fig. 10 represents

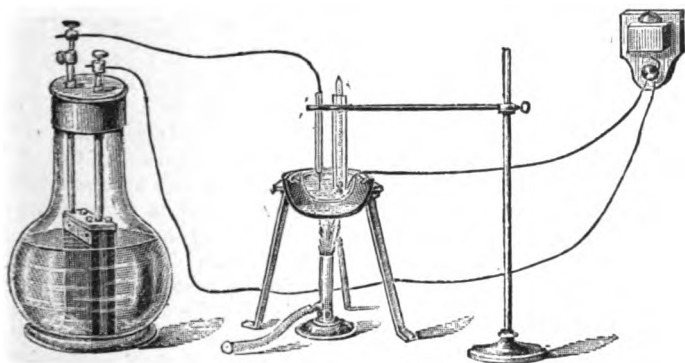

Fig. 10.

the general arrangement employed, the mercury being placed in a capsule heated over a small water bath, and the temperature ascertained by means of a thermometer plunged therein. Instead of a platinum wire coated with the substance examined, Christomanos† employs a drawn-out capillary tube into which the melted substance is sucked or poured, a platinum wire being imbedded in the material. After solidifying and standing sufficiently long to attain the normal texture of the substance examined, the capillary tube is heated in a mercury bath, electrical connections being applied to the bath and platinum wire, so that when the substance fuses contact is made and a bell rung. A similar arrangement is in use in the Paris Municipal Laboratory, the substance tested being placed in the bend of a U-shaped tube with a platinum wire in each limb, together with some mercury, which runs down and makes contact when fusion occurs.

* *Dingler's Polytechnisches Journal*, 201, p. 250.

† *Journal Soc. Chem. Industry*, 1890, p. 894; from *Berichte d. Deut. Chem. Ges.*, 1890, p. 1093.

If the fusing point of a fluid oil that has been solidified by chilling is to be determined, the bath used must be itself cooled down below the fusing point, and gradually allowed to rise in temperature. Strong brine, glycerol diluted with a little water, or calcium chloride solution may be conveniently used for temperatures below 0° . When the solidification point of a fluid oil or melted fat is to be determined, a rough approximation may often be obtained by placing some in a small narrow test-tube, or dipping into the fluid a loop of platinum wire so as to cause a small drop to adhere, and immersing in a bath of water, brine, &c., which is being cooled down by an external application of broken ice or snow and salt, &c., noting the temperatures when transparency first ceases, and when visible solidification of the whole mass has ensued. In most cases, however, the temperatures thus ascertained are too low, because superfusion is extremely apt to occur with oils and fats. If, however, a moderately large quantity of substance be used (15 to 20 grammes at least), it frequently occurs that as soon as solidification begins a more or less considerable rise in temperature of the mass takes place, just as when water cooled down below 0° in a dustless still atmosphere rises to 0° whenever freezing actually commences; or just as the temperature of a supersaturated solution of Glauber's salt (sodium sulphate) rises when the fluid sets to a crystalline mass. The higher temperature thus indicated is permanent for a time as solidification goes on, and is usually much more nearly exact than the lower one attained before solidification commenced; but even this higher one is often several degrees below the temperature of incipient fusion (and *a fortiori* below that of complete fusion) indicated when the mass has been solidified completely, allowed to stand some time, and then re-melted in a sealed-up capillary tube.

Differences of this description are more usually observed when the substances in question are mixtures of different constituents melting at different temperatures; on the other hand, a single substance in a state of moderate purity (*e.g.*, a well purified sample of a given fatty acid, such as stearic acid) usually shows but little difference between the temperatures of incipient fusion and of complete fusion in a closed capillary tube, and those where the limpid fused mass first shows signs of turbidity, and where visible complete solidification occurs, on slightly cooling the melted substance.

With some kinds of oils, *time* is an important factor in the determination of the temperature at which solidification takes place on chilling, inasmuch as frequently no solidification at all is visible on cooling for a short time to a given temperature (*e.g.*, -15° C.), whereas more or less complete solidification takes place on keeping for several hours at a temperature not so low by several degrees (*e.g.*, -5°). In most cases, if a fragment of

oil, previously solidified by chilling, be dropped into a specimen of cooled oil, solidification is brought about much sooner, the particle introduced acting as a "nucleus" and facilitating crystallisation in the well-known way observed with other bodies (*e.g.*, supersaturated solution of sodium sulphate; superfused metals; glycerol; monohydrated sulphuric acid; water chilled down whilst at rest below 0°, &c.). For determinations of this kind, baths of fairly constant low temperatures, capable of being maintained for considerable periods, are requisite; Hoffmeister uses for this purpose various saline solutions cooled externally by a freezing mixture; by suitably choosing the saline substance and the strength of its solution, baths of constant temperature are obtainable so long as any liquid remains unsolidified or any solid unmelted. Thus the following temperatures correspond with solutions of the respective strengths:—

Temperature.	Solution.
Degrees C.	
0	Distilled Water.
- 2·85 to - 3·0	Potassium nitrate, . 13 parts per 100 of water.
- 5·0	{ Potassium nitrate, . 13 " "
	{ Sodium chloride, . 3·3 " "
- 8·7 to - 9·0	Barium chloride, . 35·8 " "
- 15·4 to - 15·0	Ammonium chloride, 25 " "

Chilling baths of this description are more especially of use in the examination of lubricating oils with respect to their congealing temperatures.

The following table, mostly derived from Schädler's *Technologie der Fette und Oele*, exhibits the average melting and solidifying points of many of the more commonly occurring fats and oils:—

FREEZING AND MELTING POINTS OF OILS, &c.

Name.	Melting Point after Solidification.	Solidifying Point when Cooled (after Fusion, if Solid).
	Degrees.	Degrees.
Arachis oil,	- 3 to - 4
Almond oil,	- 20
Bassia fat (Galam butter),	28 to 29	21 to 22
Beechnut oil,	- 16·5 to - 17·5
Ben oil,	About 0
Belladonna seed oil,	- 16
Butter,	29 to 35	20 to 30
Bone grease,	44 to 45	35
Cacao butter,	33 to 34	20·5
Castor oil,	- 18
Cokernut oil,	24·5	20 to 20·5
Colza oil,	- 6
Cotton seed oil,	- 2
Cress seed oil,	- 15

FREEZING AND MELTING POINTS OF OILS, &c.—*Continued.*

Name.	Melting Point after Solidification.	Solidifying Point when Cooled (after Fusion, if Solid).
	Degrees.	Degrees.
Croton oil,	- 16
Goa butter (<i>Brindonia indica</i>),	40	32
Goose grease,	26	18
Grape seed oil,	- 16
Gourd seed oil,	- 15
Hazelnut oil,	- 17 to - 18
Hemp seed oil,	- 27 to - 23
Japanese wax,	53 to 54	40 to 41
Laurel berry fat,	38	30
Linseed oil,	- 19
Madia oil,	- 15
Nut oil,	- 28
Nutmeg butter,	43·5 to 44	33
Oleic acid,	- 6
Olive oil,	2 to 4
Poppy oil,	- 16 to - 18
Palm oil,	30 to 41	21 to 37
Pine oil,	- 18
Rape seed oil (<i>Brassica napus oleifera</i>),	- 3
Radish seed oil,	- 4
Sesamé oil,	- 5
Spindel oil (<i>Euonymus europæus</i>),	- 10
Sunflower seed oil,	- 16
Tallow,	46 to 50	36 to 40
Tobacco oil,	- 25
Train oil,	0 to - 2
Virola fat (<i>Virola sebifera</i>),	45	40
Wax,	62 to 64	About 60
Whale oil,	0 to - 2
Weld oil,	Below - 15

WIMMEL.

	Melts at	Becomes Turbid at	Temperature rises during Solidification to
	Degrees.	Degrees.	Degrees.
Sheep's tallow (fresh),	47	36	40 to 41
" (old),	50·5	39·5	44 to 45
Ox tallow (fresh),	43	33	36 to 37
" (old),	42·5	34	38
Hog's lard,	41·5 to 42	30	32
Butter (fresh),	31 to 31·5	19 to 20	19·5 to 20·5
Cacao butter,	34 to 35·5	20·5	27 to 29·5
Coker butter,	24·5	20 to 20·5	22 to 23
Palm butter (fresh),	30 to 36	21 to 24	21·5 to 35
" (old),	42	38	39·5
Nutmeg butter,	43·5 to 44	33	41·5 to 42
Beeswax,	62 to 62·5
Spermaceti,	44 to 44·5

RÜDORFF.

	Melts at	Solidifies at
	Degrees.	Degrees.
Yellow wax,	63·4	61·5 to 62·6
White wax,	61·8	61·6
Spermaceti,	43·5 to 44·3	43·4 to 44·2
Japanese wax,	50·4 to 51	...
Cacao butter,	33·5	...
Nutmeg butter,	70 to 80	...
Sheep's tallow,	46·5 to 47·4	32 to 36
Ox tallow,	43·5 to 45·0	27 to 35

The foregoing fusing and solidifying points of various solid fats are given by Wimmel and Rüdorff respectively.

The fusion point of a pure glyceride, or mixture of glycerides, is often materially altered if, as is often the case, any considerable amount of hydrolysis has taken place, either through development of "rancidity" through fermentative changes taking place on account of the presence of mucilaginous or albuminous matters, or by the agency of acids during refining, or otherwise. Hence, the numbers obtained with various samples of otherwise pure oils (*i.e.*, unadulterated with cheaper ones) are apt to vary. More nearly concordant figures are obtained if the whole of the glyceride is saponified by means of alkalis (*e.g.*, alcoholic potash), and the fatty acids separated from the resulting soap by evaporating off alcohol, dissolving the residue in hot water, acidulating with a mineral acid in excess, thoroughly agitating till all the soap is decomposed, and finally allowing to cool, and removing the cake of solidified fatty acids that separates and forms on standing.

By determining the fusing point of the fatty acid cake thus produced side by side with that similarly prepared from a sample of oil of known purity, or from a mixture of known character, useful indications as to purity or otherwise are often attainable; for example, the fatty acids from genuine olive oil usually fuse at from 22° to 26° C., and those from refined cotton seed oil at 35° to 40°, so that any considerable admixture of cotton seed oil with olive oil will usually result in yielding a cake of notably raised fusing point. The amount of rise, however, does not give any very clear indication of the amount of admixture, because, as a general rule, mixtures of different substances fuse at a temperature lower than that calculable arithmetically from the relative amounts and fusing points of the ingredients (*vide p. 73*).

The following table represents the melting and solidifying points of the mixed fatty acids obtained from various oils and fats, as given by Schädler :—

Name of Oil, &c.	Melting Point.	Solidifying Point.
	Degrees C.	Degrees C.
Apricot kernel,	4·5	0
Almond,	14	5
Arachis,	32 to 33	29 to 30
Butter,	37	33
Cacao butter,	49·5	46·5 to 47
Castor,	13	3
Charlock,	18 to 19	13
Chinese tallow,	57	52
Cotton seed,	37 to 38	32·5
Cokernut,	24 to 25	20 to 20·5
Colza,	20 to 21	14 to 14·5
Galam butter,	35·5	30
Hemp,	19	15
Lard,	38 to 39	35
Linseed,	17	13·5
Lallemantia (Gundscht),	11 to 12	...
Malabar tallow,	56·5	54·8
Margarine,	42	39·4
Nutmeg,	42·5	40
Nut (Walnut),	20	16
Olive,	26·5 to 28	21·5 to 22
Poppy,	20·5	16·5
Palm,	45 to 46	42 to 43
Rape,	21	16
Suet (Ox),	45·5	43
Sesamc,	35 to 36	31·5 to 32
Spermaceti,	13·5	...
Sunflower,	23	17
Tacamahac,	36·5	31
Tallow (Sheep),	49	46
Unguadia,	19	10
Wool grease,	41·8	40

Slightly different values have been given by other observers, the variations arising partly from differences between the particular specimens examined and partly from differences in the mode of observation. Thus the figures below given by Hübl are respectively the temperatures of complete liquefaction (as noticed by melting in a narrow test-tube, stirring with a thermometer, and noting the temperature when turbidity disappeared), and of incipient solidification (as noticed by cooling down after complete melting, and noticing when cloudiness commenced); whilst those of Bensemann are (A) the temperature of complete liquefaction, when all turbidity disappears, as determined in the above described form of capillary tube, and (B) the somewhat lower temperature when the substance was sufficiently liquefied to run down in the capillary tube, but was not thoroughly fused to a limpid fluid:—

	Fusing Point.				Solidifying Point.		
	Hübl.	Bensemann.		Allen.	Hübl.	Bach.	Allen.
	Degr. C.	A	B.	Degr.	Degr.	Degr.	Degr.
Olive oil, . . .	26·0	26 to 27	23 to 24	26·0	21·2	22·0	21·0
Almond oil, . .	14·0	5·0
Arachis oil, . .	27·7	34 to 35	31 to 32	29·5	23·8	31·0	28·0
Rape oil, . . .	20·1	21 to 22	18 to 19	19·5	12·2	15·0	18·5
Cotton seed oil, .	37·7	42 to 43	39 to 40	35·0	30·5	35·0	32·0
Sesamé oil, . .	26·0	29 to 30	25 to 26	23·0	22·3	32·5	18·5
Linseed oil, . .	17·0	24·0	13·3	...	17·5
Poppy oil, . . .	20·5	16·5
Hemp seed oil, .	19·0	15·0
Walnut oil, . .	20·0	16·5
Castor oil, . . .	13·0	3·0	2·0	...
Palm oil, . . .	47·8	50·0	42·7	...	45·5
Cokernut oil, .	24·6	24·0	20·4	...	20·5
Japan wax,	56·0	53·0
Myrtle wax,	47·5	46·0
Lard,	44·0	...	42	39·0
Tallow,	45·0	43 to 50	44 to 49	...
Shea butter, . .	39·5	38·0

The following tables by Heintz * represent the melting points of various definite mixtures of fatty acids :—

MIXTURES OF MYRISTIC AND LAURIC ACIDS.

Melting Point.	Solidification Point.	Percentage of	
		Myristic Acid.	Lauric Acid.
Degrees C.	Degrees C.		
58·8	...	100	0
51·8	47·3	90	10
49·6	44·5	80	20
46·7	39·0	70	30
43·0	39·0	60	40
37·4	35·7	50	50
36·7	33·5	40	60
35·1	32·3	30	70
38·5	33·0	20	80
41·3	36·0	10	90
43·6	...	0	100

* *Poggendorff Annalen*, 92, p. 588.

MIXTURES OF PALMITIC AND MYRISTIC ACIDS.

Melting Point.	Solidification Point.	Percentage of	
		Palmitic Acid.	Myristic Acid.
Degrees C.	Degrees C.		
62·0	...	100	0
61·1	58·0	95	5
60·1	55·7	90	10
58·0	53·5	80	20
54·9	51·3	70	30
51·5	49·5	60	40
47·8	45·3	50	50
47·0	43·7	40	60
46·5	43·7	35	65
46·2	44·0	32·5	67·5
46·2	43·7	30	70
49·5	41·3	20	80
51·8	45·3	10	90
53·8	...	0	100

MIXTURES OF STEARIC AND PALMITIC ACIDS.

Melting Point.	Solidification Point.	Percentage of	
		Stearic Acid.	Palmitic Acid.
Degrees C.	Degrees C.		
69·2	...	100	0
67·2	62·5	90	10
65·3	60·3	80	20
62·9	59·3	70	30
60·3	56·5	60	40
56·6	55·0	50	50
56·3	54·5	40	60
55·6	54·3	35	65
55·2	54·0	32·5	67·5
55·1	54·0	30	70
57·5	53·8	20	80
60·1	54·5	10	90
62·0	...	0	100

MIXTURES OF STEARIC AND MYRISTIC ACIDS.

Melting Point.	Percentage of	
	Stearic Acid.	Myristic Acid.
69·2	100	0
67·1	90	10
65·0	80	20
62·8	70	30
59·8	60	40
54·5	50	50
50·4	40	60
48·2	30	70
47·8	20	80
51·7	10	90
53·8	0	100

MIXTURES OF STEARIC AND LAURIC ACIDS.

Melting Point.	Percentage of	
	Stearic Acid.	Myristic Acid.
69·2	100	0
67·0	90	10
64·7	80	20
62·0	70	30
59·0	60	40
55·8	50	50
50·8	40	60
43·4	30	70
38·5	20	80
41·5	10	90
43·6	0	100

These tables amply illustrate the peculiarity above referred to in cases where mixtures are heated—viz., that the melting point of the mixture is almost invariably lower than that calculated from the relative proportions and fusing points of the ingredients, and in certain cases falls below the melting point of the most

MIXTURES OF PALMITIC AND LAURIC ACIDS.

Melting Point.	Percentage of	
	Palmitic Acid.	Lauric Acid.
62.0	100	0
59.8	90	10
57.4	80	20
54.5	70	30
51.2	60	40
47.0	50	50
40.1	40	60
38.3	30	70
37.1	20	80
41.5	10	90
43.6	0	100

fusible of the ingredients. Thus, in the case of a mixture of myristic and lauric acids containing equal quantities (50 per cent.) of each, since the ingredients melt respectively at 58°.8 and 43°.6 C., the melting point of the mixture would *a priori* be expected to be $\frac{58.8 + 43.6}{2} = 51.2$; whereas it actually is 37°.4, or 13°.8 lower than the calculated temperature, and 6°.2 lower than the fusing point of the most fusible ingredient.

Dalican's Method.—The following table by Dalican * represents the solidifying points of various mixtures of pure free stearic and oleic acids, analogous to those obtained by saponifying tallow completely and separating the fatty acids from the soaps formed; these were deduced by determining the temperature to which the thermometer rose when some 20 grammes of mixed pure fatty acids were placed in a test-tube at a temperature a little above the solidifying point, and allowed to cool slowly; when incipient solidification became visible the contents of the tube were stirred with the thermometer immersed therein, giving a rotary movement three times from right to left, and three times in the opposite direction; during this stirring the thermometer usually slightly fell just at first, but in every case rose again to a point where the temperature remained stationary for about two minutes, the disengagement of latent heat during solidification balancing the loss of heat by radiation and convection, &c. The temperatures quoted are the stationary ones thus observed with the various mixtures examined. The joint percentages given in the table only add up to 95, the average yield of total fatty acids from tallow being taken as 95 per cent., after

* *Moniteur Scientifique*, Paris, 1868.

allowing for small quantities of water present and loss of weight by elimination of glycerol (*vide* Chap. VIII.) :—

Temperature Centigrade.	Stearic Acid.	Oleic Acid.	Temperature Centigrade.	Stearic Acid.	Oleic Acid.
40	35·15	59·85	45·5	52·25	42·75
40·5	36·10	58·90	46	53·20	41·80
41	38·00	57·00	46·5	55·10	39·90
41·5	38·95	56·05	47	57·95	37·05
42	40·90	54·10	47·5	58·90	36·10
42·5	42·75	52·25	48	61·75	33·25
43	43·70	51·30	48·5	66·50	28·50
43·5	44·65	50·35	49	71·25	23·75
44	47·50	47·50	49·5	72·20	22·80
44·5	49·40	45·60	50	75·05	19·95
45	51·30	43·70			

The method of manipulation thus employed by Dalican is applicable in the case of most other substances the solidifying point of which is required ; but the amount of rise indicated by the thermometer above the temperature of incipient solidification varies considerably in different cases, a constant temperature for two minutes or more not being always attained. Finkener* finds that more concordant valuations are obtainable if the vessel containing the fused fatty matter is enclosed in an envelope of wadding, or jacketed with a wooden envelope, so as to diminish the rate of cooling.

Solidifying Point of Tallow Fatty Acids.	Percentage of "Stearine" (Solid Fatty Acids) of Solidification Point				
	Degrees C.	48 Degrees C.	50 Degrees C.	52 Degrees C.	54·8 Degrees C.
10		3·2	2·7	2·3	2·1
15		7·5	6·6	5·7	4·8
20		13·0	11·4	9·7	8·2
25		19·2	17·0	14·8	12·6
30		27·9	23·2	21·4	18·3
35		39·5	34·5	30·2	25·8
40		57·8	49·6	43·5	37·0
42		66·6	57·6	50·5	42·9
44		77·0	66·2	58·4	49·8
46		87·5	75·8	67·0	56·8
48		100·0	87·2	76·6	65·0
50	...		100·0	87·0	74·5
52	...			100·0	84·8
54	...				95·3
54·8	...				100·0

* *Journal Soc. Chem. Industry*, 1889, p. 423, and 1890, p. 1071.

De Schepper and Geitel give the foregoing table representing the amounts of mixed solid fatty acids of different solidification points practically obtainable from tallow, when these acids are separated from oleic acid to such an extent as to possess the solidification points named.

The same authors give the following analogous table for the relative amounts of mixed solid fatty acids practically obtainable from palm oil :—

Solidifying Point of Palm Oil Fatty Acids.	Percentage of "Stearine" (Solid Fatty Acids) of Solidification Point				
	Degrees C.	48 Degrees C.	50 Degrees C.	52 Degrees C.	55·4 Degrees C.
10		4·2	3·6	3·2	2·6
15		10·2	9·8	7·8	6·6
20		17·4	15·0	14·4	11·0
25		26·2	22·4	19·3	16·2
30		34·0	30·5	26·6	22·3
35		45·6	40·8	35·8	29·8
40		63·0	55·2	48·6	40·6
42		70·5	62·2	55·2	45·5
44		79·2	70·2	62·0	51·4
46		89·4	78·8	69·8	57·8
48		100·0	88·0	78·6	65·0
50		...	100·0	89·6	73·4
52		100·0	82·8
54		92·2
55·4		100·0

CHAPTER V.

SPECIFIC GRAVITY AND VISCOSITY.

SPECIFIC GRAVITY OF OILS, FATS, &c.

INASMUCH as the majority of natural oils, fats, and similar substances are mixtures of more than one constituent, the relative proportions, and even the nature of the ingredients being subject to some degree of variation, it results that the general physical characters of any given oil, &c., are liable to fluctuation within certain limits. This is particularly the case with the specific gravity of such materials, differences in the climate and soil in which seed-bearing plants are grown, in the degree of cultivation and the maturity of the crop, and such like causes

often producing measurable differences in the relative density of the oil extracted; as also, to some extent, does the method of extraction adopted, the first runnings obtained by pressure in the cold being often perceptibly lighter bulk for bulk than those obtained later by hot pressure. In similar fashion, variations in the particular breed of animal (*e.g.*, in the case of oxen and sheep), the part of the body from which the fat is extracted, the mode of feeding, &c., often correspond with analogous fluctuations in the case of animal fats; added to which, the method of refinement adopted and the degree of purification effected, cause variations in proportion to the amount of residual mucilaginous or albuminous matters left unremoved; whilst the age of the sample is often a material point, many kinds of oil having a tendency to absorb oxygen from the air, thereby becoming more dense.

Notwithstanding these sources of variation, however, it is often possible to obtain useful information as to the freedom or otherwise of oils, &c., from admixture with adulterating substances by examining their specific gravity; or, in many cases, preferably, the specific gravity of the free fatty acids obtainable from them by saponification. This determination is most accurately effected by means of the *pyknometer** (specific gravity bottle); but since, excepting in comparatively few special cases (*e.g.*, butter analysis), a very high degree of accuracy is unnecessary on account of the possible natural fluctuations in density, simpler instruments are in most cases sufficient for the purpose in view, more especially when checked or "calibrated," as described below. Thus for most fluid oils the indications of a fairly well made *areometer* (hydrometer), used at a standard temperature, are sufficiently accurate; whilst either for ordinary temperatures or for more elevated ones, the *hydrostatic balance* is extremely convenient. In using this latter instrument at higher temperatures (*e.g.*, near that of boiling water), it should not be forgotten that if the plummet immersed in the liquid to be examined (as shown in Figs. 11 and 12) be made of glass, it will displace more than 0.2 per cent. (or upwards of 2 per mille) more fluid at near the boiling point of water than at 15° †; so that if originally constructed to give accurate indications at 15°, the values indicated at near 100° will be more than 2 per mille too high on account of the greater displacement; whence, in the

* For a description of some highly accurate forms of this instrument and their mode of use, together with a discussion of the corrections indispensable when results are required to be accurate to a unit in the fourth decimal place (± 0.0001), and *a fortiori* to one in the fifth place (± 0.00001), vide a paper by the author, *Journ. Soc. Chem. Industry*, 1892, p. 297.

† The cubical coefficient of expansion of glass is near $\frac{1}{40,000}$; so that a rise of temperature of 85° represents an increment in volume of $\frac{85}{40,000} = 2.125$ per mille.

case of fluid oils, the specific gravity of which is usually from $\cdot 9$ to $\cdot 95$, the indications at near 100° will be close to $\cdot 002$ too high. Analogous errors of excess apply to all glass aræometers and pyknometers when graduated at one temperature and used at a higher one.

Another matter to be remembered is that the numerical value arrived at expresses different things, according as the water with which the instrument is graduated is at one temperature or another; this applies equally to the indications of the pyk-

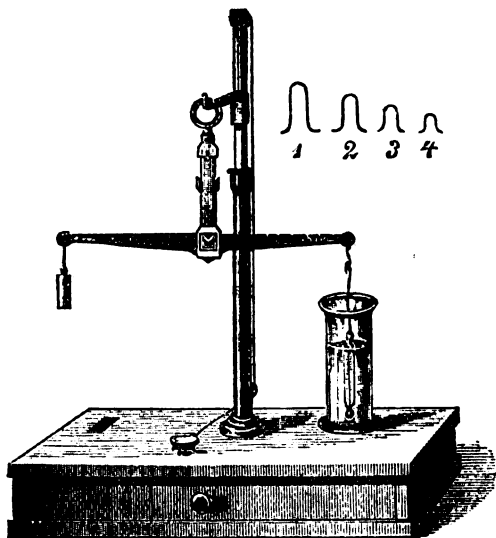

Fig. 11.

nometer, the aræometer, and the hydrostatic balance. When the indications represent the ratio between the weight of a given volume of substance and that of the same weight of water, *both at the same temperature t°* , the value is the *specific gravity at t°* ; thus the specific gravity at 100° of a given oil or melted wax is the weight of a given volume of substance compared with that of the same weight of water also at 100° . If, however, the oil be at t° , and the water at a different temperature, T , the value is neither the specific gravity at t° nor that at T . If $T = 4^\circ \text{C.}$, the value is the *weight in grammes at t° of 1 c.c. of oil*, since at 4°C. 1 c.c. of water weighs 1 gramme; this value is often considerably different from the specific gravity of the oil at t° , the more so the higher the value of t ; thus if $t = 100^\circ \text{C.}$, since 1 c.c. of water at 100° weighs 0.9586 gramme, the weight of 1 c.c. of oil at 100° will be only 0.9586 times the specific gravity of the oil at 100° ; *i.e.*, the latter value is more than 4 per cent. in excess of the

former one. Unfortunately, most observers have recorded their results in neither of these two forms, but have used a mode of expression where T is not 4° , and is not $= t$. The result thus expressed is *the relative density of water at t referred to water at T* , sometimes expressed as the relative density at $\frac{t}{T}$; when $T = 15\cdot5$ C., a temperature frequently chosen, this value represents 1·0009 times the weight of 1 gramme of oil at t° , since 1 c.c. of water at $15\cdot5$ weighs ·9991 gramme.

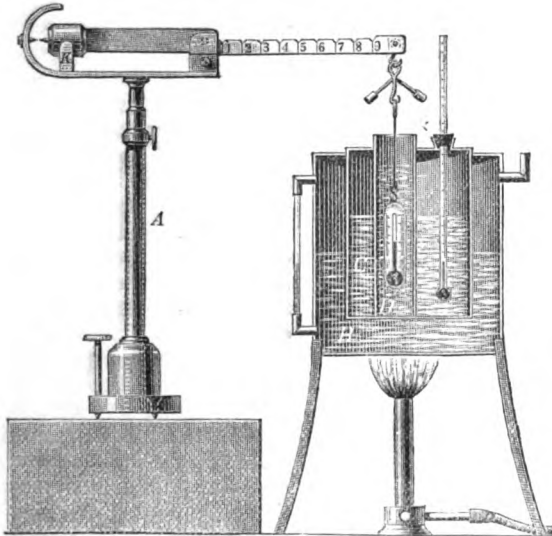

Fig. 12.

Lefebre's Oleometer.—Fig. 13 represents Lefebre's aræometer, especially intended for oils the specific gravity of which at $15\cdot5$ ranges from 0·9 to 0·95; the instrument is so graduated that the specific gravity is directly read off when immersed in a fluid at the standard temperature of $15\cdot5$; at various points the average specific gravities of normal oils of different kinds are marked off (linseed oil, olive oil, &c.); usually, to save figures, only the second and third decimal places are given—*i.e.*, 35 indicates ·935, 8 represents ·908, and so on. If the temperature differ slightly from the normal one of $15\cdot5$, a correction is made by adding (or subtracting) $\frac{2}{3} \times \cdot001$ for every degree of temperature above (or below) the standard, this correction being based on the fact that most oils expand on heating to nearly the same extent, so that the specific gravity becomes lowered by about ·00068 per 1° C. (*vide* p. 93).

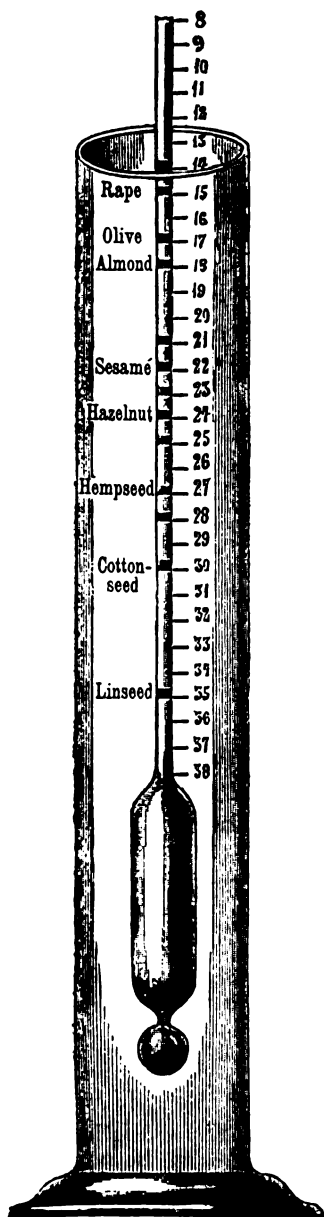

Fig. 13.

When it is required to determine the specific gravity of an oil, &c., at a temperature somewhat elevated (say at near 100°), some form of heating arrangement must be employed, whereby the vessel containing the oil, &c., can be constantly maintained at the required temperature for some time. Fig. 12 illustrates a form of hot waterbath thus used for a Westphal hydrostatic balance.

When temperatures other than 100° , but higher than the ordinary atmospheric temperatures are required, the hot air arrangement indicated by Fig. 14 may be employed; in this case the vessel, C, containing the oil, &c., to be examined, is heated by a hot air bath, B, the ascending hot gases from a ring burner being made to circulate as indicated by the arrows. The temperature of the inner hot air space is shown by the thermometer, D, and should not differ much from that of the oil itself, as indicated by a thermometer immersed therein (in the figure, as also in Fig. 12, this is enclosed inside the plummet*). A thermostat, or heat regulator where the gas supply is automatically regulated, should be employed in addition.

Fig. 15 represents Ambühl's arrangement where the vessel containing the oil is heated in a current of vapour (steam from boiling water, or other vapour emitted by a fluid of convenient boiling point).

* Fletcher has recently constructed a *thermohydrometer*, consisting of an ordinary areometer with enclosed thermometer, so as to read off the temperature of the fluid examined simultaneously with the indicated relative density.

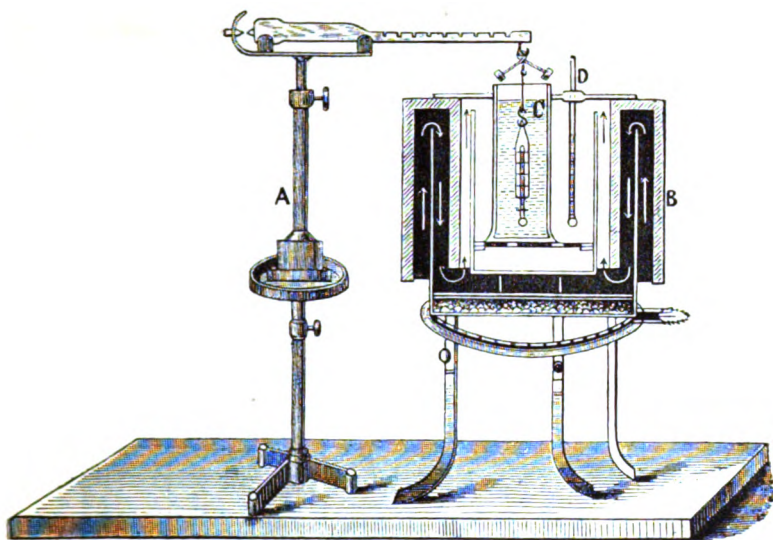

Fig. 14.

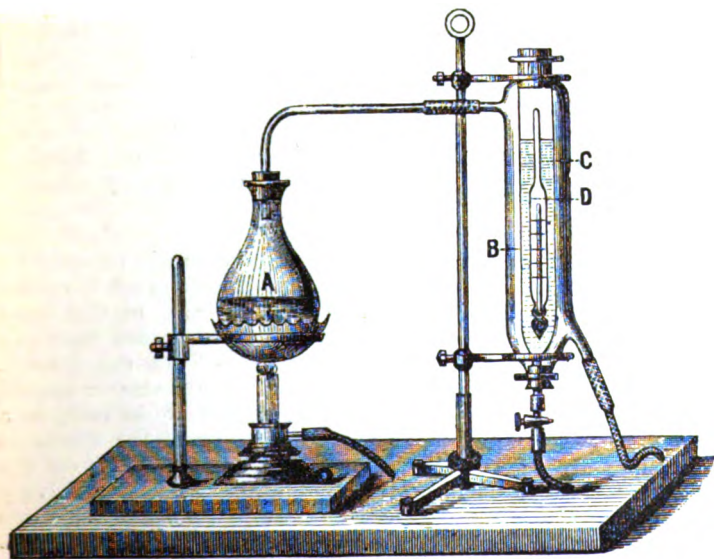

Fig. 15.

In the Paris Municipal Laboratory, a peculiar kind of "thermal aræometer," constructed by Langlet, is in use for the examination of olive oil. This is an aræometer with an internal thermometer, so adjusted that when the instrument is placed in pure olive oil, the level of the fluid indicated on the stem and the thermometer reading are practically the same; if the oil be warmed so as to become lighter, the hydrometer sinks to an increased depth, and the thermometer column rises through the same length, so that the two readings always correspond. If, however, the oil be not genuine olive oil, but contain an admixture of other oil of different density, the readings will not agree. Thus, the following pairs of readings correspond with certain oils other than olive oil and various mixtures (Muntz):—

	Thermometer Reading.	Reading on Stem.
	Degrees C.	Degrees C.
Earthnut oil,	18·9	11·0
Cotton seed oil,	18·9	10·5
3 Parts olive oil to 1 of cotton seed oil,	18·1	16·1
2 " " 1 " " "	18·6	15·8
3 " " 1 of sesamé oil,	18·3	16·5
2 " " 1 " " "	18·6	16·1
3 " " 1 of colza oil,	18·3	18·5
3 " " 1 of earthnut oil,	18·1	17·2
2 " " 1 " " "	18·7	17·5
52 " " 48 " " "	18·7	17·4

CONSTRUCTION OF TABLES OF ERRORS FOR HYDROMETERS AND HYDROSTATIC BALANCES.

Hydrometers, as usually sold, are not infrequently affected by errors of construction and graduation, sufficiently great to render their indications inexact to at least \pm one unit in the third decimal place, and sometimes much more, quite apart from any error arising from the difficulty of reading off the exact level. To do this with as little error as possible, the hydrometer should be floated in a jar with a white strip of enamel at its back, or a strong light so placed that the lowest point of the meniscus formed by the upper part of the fluid can be read off on the hydrometer scale. Unless the fluid examined be excessively dark coloured, this can generally be done pretty readily, the eye being level with the bottom of the meniscus (as in reading a burette).

To eliminate, as far as possible, errors of graduation, it is

necessary to construct for each instrument a table of errors, deduced by directly comparing at the same temperature the values obtained with different fluids simultaneously examined by means of an accurate pycnometer, and with the hydrometer. The following illustration will suffice to indicate the mode of construction of such a table of errors for a hydrometer intended to show at 15°·5 C. values ranging between ·900 and ·950; when such a table is carefully prepared, the corrected reading of a tolerably sensitive hydrometer should be exact within \pm two, or even \pm one unit in the fourth decimal place. The figures are expressed on the thousandfold scale,* three comparisons being made respectively near the top, middle, and bottom of the hydrometer scale.

True Specific Gravity at 15°·5 by Pycnometer.	Hydrometer Reading at 15°·5.	Difference.
948·4	947·5	+ 0·9
924·7	925·0	- 0·3
901·1	902·5	- 1·4

From these comparisons the following table of errors is deduced by interpolation:—

Hydrometer Reading at 15°·5.	Correction to be added to obtain the True Specific Gravity.	Corrected Specific Gravity at 15°·5.
900·0	- 1·50	898·5
905·0	- 1·25	903·75
910·0	- 1·00	909·0
915·0	- 0·75	914·25
920·0	- 0·50	919·5
925·0	- 0·30	924·7
930·0	- 0·05	929·95
935·0	+ 0·20	935·2
940·0	+ 0·45	940·45
945·0	+ 0·75	945·75
950·0	+ 1·00	951·0

In similar fashion, a table of errors may be constructed for a hydrostatic balance; thus, the following numbers were obtained with such an instrument of fairly good construction, the values being here expressed on the ordinary scale, and not multiplied by 1,000, the temperature throughout being 15°·5:—

* To save decimals, specific gravity values are often quoted after multiplication by 1,000: thus, an oil of specific gravity 0·967 is said "to have the gravity 967," and so on.

True Specific Gravity by Pycnometer.	Value indicated by Hydrostatic Balance.	Difference.
0·9976	0·9995	- 0·0019
0·9517	0·9530	- 0·0013
0·9098	0·9100	- 0·0002
0·8524	0·8520	+ 0·0004

From these determinations the following table of errors is calculated by interpolation:—

Specific Gravity indicated by Hydrostatic Balance.	Correction to be added to obtain the True Specific Gravity.	Corrected Specific Gravity.
0·85	+ ·0004	·8504
0·86	+ ·0003	·8603
0·87	+ ·0002	·8702
0·88	+ ·0001	·8801
0·89	0	·8900
0·90	- ·0001	·8999
0·91	- ·0002	·9098
0·92	- ·0005	·9195
0·93	- ·0008	·9292
0·94	- ·0010	·9390
0·95	- ·0013	·9487
0·96	- ·0014	·9586
0·97	- ·0015	·9685
0·98	- ·0017	·9783
0·99	- ·0018	·9882
1·00	- ·0019	·9981

Considerably larger corrections than most of those indicated in this table have sometimes to be applied to instruments as purchased, in order to deduce the true specific gravities from the direct results of observation.

Hydrometer Scales.—A considerable number of more or less arbitrary scales for aræometers are in use, a circumstance often leading to much practical inconvenience. The simplest or "gravity" scale is that where the specific gravity of the fluid is directly indicated by the level to which the instrument sinks in the fluid (at the normal temperature)—*e.g.*, in Lefebvre's oleometer (p. 80). Twaddell's scale is not much inferior in simplicity, each degree on that scale representing an alteration of 5 units in gravity on the thousandfold scale (p. 83), and the valuation being given by the formula

$$S = 1000 + 5n,$$

where S is the specific gravity on the thousandfold scale, and *n* the hydrometer reading; thus 10° T represents specific gravity

1·050 ; 100° T, specific gravity 1·500 ; 150° T, specific gravity 1·750 ; and so on. The same rule applies in the case of a fluid having a density less than that of water, the value of n being then negative, so that if $n = -10° T$, the specific gravity would be ·950, and so on ; the negative-scale Twaddell hydrometer, however, is but rarely used. A variety of other scales are also in use, more especially in different parts of the Continent ; the following table of formulæ is given by Benedikt, expressing the relative values of their degrees, S and n having the same meanings as above :—

Aræometer of	Temperature.	Fluids Heavier than Water.	Fluids Lighter than Water.
	Degrees.		
Balling, . . .	17·5 C.	$S = \frac{200}{200 - n}$	$S = \frac{200}{200 + n}$
Beaumé, . . .	12·5 C.	$S = \frac{144}{144 - n}$	$S = \frac{144}{134 + n}$
Beaumé,* . . .	15·0 C.	$S = \frac{144·3}{144·3 - n}$	$S = \frac{144·3}{134·3 + n}$
Beaumé,† . . .	17·5 C.	$S = \frac{146·78}{146·78 - n}$	$S = \frac{146·78}{136·78 + n}$
Beck, . . .	12·5 C.	$S = \frac{170}{170 - n}$	$S = \frac{170}{170 + n}$
Brix, . . .	{ 12·5 R. 15·625 C.	$S = \frac{400}{400 - n}$	$S = \frac{400}{400 + n}$
Cartier, . . .	12·5 C.	...	$S = \frac{136·8}{126·1 + n}$
Fischer, . . .	{ 12·5 R. 15·625 C.	$S = \frac{400}{400 - n}$	$S = \frac{400}{400 + n}$
Gay Lussac,‡ . . .	4 C.	$S = \frac{100}{n}$	$S = \frac{100}{n}$
E. G. Greiner, . . .	{ 12·5 R. 15·625 C.	$S = \frac{400}{400 - n}$	$S = \frac{400}{400 + n}$
Stoppani,§ . . .	{ 12·5 R. 15·625 C.	$S = \frac{166}{166 - n}$	$S = \frac{166}{166 + n}$

* $S = \frac{144·3}{144·3 + n}$ for lighter fluids (Schädler).

† $S = \frac{146·78}{146·78 + n}$ for lighter fluids (Schädler).

‡ $S = \frac{100}{100 - n}$ for heavier fluids, and $= \frac{100}{100 + n}$ for lighter ones (Schädler).

§ $S = \frac{160}{160 - n}$ for heavier fluids, and $= \frac{160}{160 + n}$ for lighter ones (Schädler).

Lunge and Hurter (*Alkali Maker's Pocket-book*) regard the series of values got by means of the formula $S = \frac{144.3}{144.3 - n}$ as the only "rational" one of the various Beaumé scales in use; taking the formula at 15° C., the specific gravity of water at 15° = 0° B.; whilst 66° B. represents specific gravity $\frac{144.3}{144.3 - 66} = 1.8426$. The following table exhibits the relationships between the values of "rational" Beaumé degrees, Twaddell degrees, and true specific gravity:—

Beaumé.	Twaddell.	Specific Gravity.	Beaumé.	Twaddell.	Specific Gravity.
0	0	1.000	36.0	66.4	1.332
0.7	1.0	1.005	38	71.4	1.357
1.0	1.4	1.007	40	76.6	1.383
1.4	2.0	1.010	42	82.0	1.410
2.0	2.8	1.014	44	87.6	1.438
2.7	4.0	1.020	46	93.6	1.468
4.0	5.8	1.029	48	99.6	1.498
5.0	7.4	1.037	50	106.0	1.530
6.7	10.0	1.050	52	112.6	1.563
8.0	12.0	1.060	54	119.4	1.597
10.0	15.0	1.075	56	127.0	1.635
14.0	21.6	1.108	58	134.2	1.671
16.0	25.0	1.125	60	142.0	1.710
18.8	30.0	1.150	61	146.4	1.732
20.0	32.4	1.162	62	150.6	1.753
23.0	38.0	1.190	63	155.0	1.775
25.0	42.0	1.210	64	159.0	1.795
27.0	46.2	1.231	65	164.0	1.820
30.0	52.6	1.263	66	168.4	1.842
33.0	59.4	1.297	67	173.0	1.865

RELATIVE DENSITIES OF THE PRINCIPAL OILS, FATS, &c.

Many experimenters have published the results of their determinations of the specific gravities of genuine oils, &c.; in most instances the observed limits of variation in this respect are not very wide, being mainly dependent on the freedom from rancidity and free fatty acids; the degree of refinement (or freedom from mucilaginous matter, &c.); the age of the sample (whether oxygen has been absorbed or not), and so on. In many cases a measurable difference is observable between the density of the oil first expressed, especially when cold drawn, and that of the later portions obtained by the aid of heat, the latter being generally heavier. The following figures are given by Schädler

as expressing the average values of the specific gravities at 15° of a large number of the more commonly occurring vegetable and other oils :—

Name of Oil	Oil from Seed of	Specific Gravity at 15°.
Almond oil,	<i>Amygdalus communis</i> ,	·9180
Arachis oil (earthnut oil),	<i>Arachis hypogæa</i> ,	·9202
Bassia fat (Illipé butter),	<i>Bassia longifolia</i> , Roxb.,	·9580
Ben oil,	<i>Moringa oleifera</i> ,	·9120
Belladonna seed oil,	<i>Atropa belladonna</i> ,	·9250
Beechnut oil,	<i>Fagus sylvatica</i> ,	·9225
Camelina oil (gold of pleasure),	<i>Camelina sativa</i> ,	·9328
Cacao butter,	<i>Theobroma cacao</i> ,	·9000
Castor oil,	<i>Ricinus communis</i> ,	·9667
Cokernut oil,	<i>Cocos nucifera</i> ,	·9250
Colza oil,	<i>Brassica campestris</i> ,	·9150
Cotton seed oil (raw),	<i>Gossypium herbaceum</i> ,	·9224
" (refined),	" " " " " "	·9230
Croton oil,	<i>Croton tiglium</i> , "	·9550
Euonymus oil (spindel oil),	<i>Euonymus europæus</i> ,	·9380
Grape seed oil,	<i>Vitis vinifera</i> ,	·9202
Hemp seed oil,	<i>Cannabis sativa</i> ,	·9276
Gourd seed oil,	<i>Cucurbita pepo</i> ,	·9251
Haselnut oil,	<i>Corylus avellana</i> ,	·9154
Linseed oil (raw),	<i>Linum usitatissimum</i> ,	·9299
" (boiled),	" " " " " "	·9411
Melon seed oil,	<i>Cucurbita pepo</i> ,	·9251
Madia oil,	<i>Madia sativa</i> ,	·9350
Mustard oil,	<i>Sinapis nigra</i> ,	·9182
Maize oil,	<i>Zea mais</i> ,	·9210
Nut oil (walnut oil),	<i>Juglans regia</i> ,	·9260
Nutmeg oil,	<i>Myristica moschata</i> ,	·9480
Olive oil (greenish yellow),	<i>Olea europæa</i> ,	·9144
" (best quality),	" " " " " "	·9177
" (Galipoli),	" " " " " "	·9196
Pine oil (red pine seed oil ; } pinaster seed oil), }	<i>Pinus picea</i> ,	·9235
Palm oil,	<i>Elais guinensis</i> , &c.,	·9046
Poppy seed oil,	<i>Papaver somniferum</i> ,	·9245
Yellowhorn poppy oil,	<i>Papaver glaucium</i> ,	·9250
Plum kernel oil,	<i>Prunus domestica</i> ,	·9127
Radish seed oil,	<i>Raphanus sativus</i> ,	·9162
Rape oil,	<i>Brassica napus oleifera</i> ,	·9157
Red rape oil,	<i>Hesperis matronalis</i> ,	·9282
Winter rape oil,	<i>Brassica rapa olifera biennis</i> ,	·9154
" (refined),	" " " " " "	·9177
Sesamé oil,	<i>Sesamum orientale</i> ,	·9235
Sunflower seed oil,	<i>Helianthus annuus</i> ,	·9262
Tobacco seed oil,	<i>Nicotiana tabacum</i> ,	·9232
Weld seed oil,	<i>Reseda luteola</i> ,	·9358

ANIMAL OILS, &c.

Name of Oil.	Source.	Specific Gravity at 15°.
Bone fat,	Bones,	·9185
Cod liver oil,	Gadus morrhua, &c.,	·9200
" (purified),	" "	·9270
" (Labrador),	" "	·9237
Mutton tallow,	Sheep,	·9147
Seal oil,	Phoca vitulina, &c.,	·9246
" (purified),	" "	·9261
Sperm oil,	Physeter macrocephalus,	·9115
Whale oil (train oil),	Balena mysticetus,	·9250
" (white),	" "	·9258

The following determinations of the specific gravity at 15° of various *solid* fats, &c., are given by Hager and Dieterich :—

	Hager.	Dieterich.
Beef tallow,	·925 to ·929	·952 to ·953
Sheep's tallow,	·937 to ·940	·961
Hog's lard,	·931 to ·932	...
Stearine,	·971 to ·972
Stearic acid (fused),	·964	...
" (crystallised),	·967 to ·969	...
Butter fat (clarified),	·938 to ·940	...
" (several months old),	·936 to ·937	...
Artificial butter,	·924 to ·930	...
Cacao butter (fresh),	·950 to ·952	·980 to ·981
" (very old),	·945 to ·946	...
Beeswax (yellow),	·959 to ·962	·963 to ·964
" (white),	·919 to ·925	·973
Japanese wax,	·977 to ·978	·975
" (very old),	·963 to ·964	...
Spermaceti,	·960
Colophony (American),	1·100	1·108
" (French),	1·104 to 1·105
Galipot resin (purified),	1·045
Crude ozokerite,	·952
Ceresin (yellow),	·925 to ·928	·922
" (half white),	·923 to ·924	·920
" (pure white),	·905 to ·908	·918

The following valuations of specific gravity at 37°·8 C. = 100° F. are given by Muter* :—

* Spon's *Encyclopædia of Arts and Manufactures*, ii., p. 1,469. The values quoted are the numbers expressing the weights of given volumes of

Oil.	Limits of Specific Gravity.	Average.
Almond oil,8980 to .9109	.9056
Arachis (groundnut) oil,9073 ,, .9020	.9085
Castor,9550 ,, .9576	.9558
Cokernut,9103 ,, .9152	...
Cotton seed (brown),9170 ,, .9197	.9176
" (refined—salad oil),9130 ,, .9140	.9136
Cod fish oil,9114 ,, .9220	.9176
Cod liver oil,9173 ,, .9180	.9179
Hemp seed oil,9190 ,, .9. 95	.9193
Lard oil,9076 ,, .9082	.9078
Linseed (raw),9232 ,, .9300	.9252
" (boiled),9320 ,, .9440	.9380
Neat's foot,9052 ,, .9079	.9070
Nut,9080 ,, .9090	.9085
Olive,9052 ,, .9079	.9070
Poppy,9150 ,, .9155	.9154
Rape,9060 ,, .9077	.9067
" refined (Colza),9053 ,, .9065	.9067
Seal,9136 ,, .9195	.9179
Sperm,8672 ,, .8963	.8724
Whale,9056 ,, .9066	.9060

Since 1 c.c. of water weighs 1.0000 grm. at 4°, .99908 at 15°.5, and .9933 at 37°.8, these values, when reduced to the standard of "specific gravity at 37°.8 referred to water at 15°.5"

(specific gravity at $\frac{37°.8}{15°.5}$), will be less in the proportion $\frac{.9933}{.99908}$ — i.e., less by 0.58 per cent.; that is, less by from .0051 to .0056. If reduced to the standard of "weight at 37°.8 in grms. per c.c.," they will be less in the proportion $\frac{.9933}{1.0000}$ — i.e., by .67 per cent.; that is, less by from .0058 to .0064.

Classification of Oils and Fats, &c., according to their Relative Densities.—The following tables are given by A. H. Allen,* exhibiting the general classification of oils and fats, &c., according to their respective densities; the relative density at

15°.5 being taken in the case of liquid oils and that at $\frac{99°}{15°.5}$ in the case of fats, &c., solid or nearly so at ordinary temperatures:—

oil at 37°.8, referred to the weight of the same volume of water at the same temperature as unity, and consequently are the true specific gravities at 37°.8 (p. 78). Muter, however, prefers to call them "actual densities;" an unfortunate term, as the figures are very different from the true densities.

* *Commercial Organic Analysis*, vol. ii., p. 89, *et seq.*

OILS LIQUID AT 15° C.

Class of Oil.	Specific Gravity at 15° C. = 60° F.				
	.875 to .884.	.884 to .912.	.912 to .920.	.920 to .937.	.937 to .970.
Vegetable oils.	None.	None.	Olive. Almond. Ben. Arachis. Rape. Colza. Mustard.	Cotton seed. Sesamé. Sunflower. Hazelnut. Poppysced. Hemp seed. Linseed (raw). Walnut. Cokernut oleine (manufactured).	Japanese wood. Croton. Castor. Linseed (boiled). Blown oils (manufactured).
			Essentially non-drying oils.	More or less drying oils.	
Terrestrial Animal oils.	None.	None.	Neat's foot. Bone. Lard and tallow oils (manufactured).	None.	None.
Marine Animal oils.	Sperm. Bottlenose.	None.	Shark liver.	Whale. Porpoise. Seal. Menhaden. Cod liver. Shark liver.	None.
Free fatty acids.	None.	Oleic acid.	...	Linolic acid.	Ricinoleic acid.
Hydro-carbon oils.	Shale products. Petroleum products.	Shale products. Petroleum products.	Heavy Petroleum products.	None.	None.

OILS, &C., PASTY OR SOLID AT 15° C. = 60° F.

Arranged according to their Specific Gravity when Melted.

Class of Oil, &c.	Relative Density at $\frac{99}{15^{\circ}C.}^{\circ}$			
	750 to '800.	'800 to '855.	'855 to '861.	'861 to '867.
Vegetable fats.	None.	None.	Palm oil. Cacao butter.	Palmnut oil. Cokernut oil. Japan wax. Myrtle wax. Cokernut and Cotton seed stearine (manufactured).
Animal fats.	None.	None.	Tallow. Lard. Suet. Dripping. Bone fat. Oleomargarine and Butterine (manufactured).	Butter fat.
Vegetable and Animal waxes.	None.	Spermaceti. Beeswax. Chinese wax. Carnauba WAX.	None.	None.
Free fatty acids.	None.	Stearic acid. Palmitic acid. Oleic acid.	None.	None.
Hydrocarbons.	Paraffin wax. Ozokerite.	Shale products. Petroleum products.	Vaseline.	None.

* These relative density values were mostly taken with the plummet apparatus (Westphal's hydrostatic balance) and *not* corrected for the expansion of the glass plummet used; many of the values are, therefore, about 0.2 per cent. too high—i.e., too high by nearly .002 (p. 77).

Rosin oils and rosin are not included in these tables, these substances having specific gravities mostly higher than any therein mentioned—viz., from .97 to upwards of 1.0; similar remarks apply to some of the highest-boiling petroleum and shale hydrocarbons.

Variation of Density of Oils, &c., with Temperature.—
Like most other substances, oils and melted fats, &c., expand

Name of Oil or Fat, &c.	Ratio of Weight of a given Volume of Substance at t° , to that of the same Volume of Water at 15° considered as 1000.			Mean Variation per 1° Alteration in Temperature.
	$t=15^{\circ}$.	$t=40^{\circ}$ - 80° .	$t=98^{\circ}$ - 99° .	
Arachis oil (groundnut oil), .	922	...	867.3	.66
Beeswax,	835.6 at 80°	822.1	.75
Butter fat,	904.1 at 40°	867.7	.62
Castor oil,	965.5	...	909.6	.65
Cod liver oil,	927.5	...	874.2	.65
Cokernut oleine,	926.2	...	871.0	.67
Cokernut stearine,	895.9 at 60°	869.6	.67
Cokernut butter,	911.5 at 40°	873.6	.64
Cotton seed oil,	925	...	872.5	.63
Doegling oil (bottlenose whale),	880.8	...	827.4	.64
Japanese wax,	901.8 at 60°	875.5	.69
Lard,	898.5 at 40°	860.8	.65
Linseed oil,	935	...	880.9	.65
Menhaden oil,	932	...	877.4	.65
Neat's foot oil,	914	...	861.9	.63
Niger seed oil,	927	...	873.8	.64
Palm butter,	893.0 at 50°	858.6	.72
Porpoise oil,	926	...	871.4	.65
Rape oil,	915	...	863.2	.62
Seal oil,	924	...	873.3	.62
Sesamé oil,	921	...	867.9	.62
Spermaceti,	835.8 at 60°	808.6	.72
Sperm oil,	883.7	...	830.3	.65
Tallow,	895.0 at 50°	862.6	.67
Whale oil,	930.7	...	872.5	.70
Paraffin wax,	780.5 at 60°	753.0	.72
Commercial "stearine" (crude stearic acid),	859.0 at 60°	830.5	.75
Commercial "oleine" (im- pure oleic acid),	903.2	...	848.4	.66

on heating; it is somewhat remarkable that nearly all bodies of this description expand at about the same rate (within not very wide limits of departure from the average), so that 1 c.c. of substance always increases to about 1.00075 c.c. by rise of temperature of 1° C. The effect of this on the density is to diminish it in the inverse proportion; so that an oil, &c., the specific

gravity of which at 15° is from .9 to .95, will become diminished in specific gravity to $\frac{.9}{1.00075}$ to $\frac{.95}{1.00075}$ by rise of 1° in temperature—i.e., the diminution in the specific gravity is .00067 to .00071. Thus the preceding values were obtained by A. H. Allen; * for the sake of convenience, and to avoid decimals, all the figures are multiplied by 1,000.

From these values it results that whilst glyceridic oils fluid at the ordinary temperature diminish in specific gravity between 15° and 98° C. at close to the average rate of .64 per 1° (uncorrected for plummet expansion; somewhat more when corrected), glycerides of higher melting point (like Japanese wax and palm butter) and waxes (beeswax, spermaceti, paraffin wax) diminish in specific gravity at a slightly higher rate, averaging about 0.7 per 1°. In all cases, however, the rate is sensibly near to $\frac{2}{3} \times .001$ per 1° C., reckoned on the usual specific gravity scale (water = 1) and not multiplied by 1,000.

Figures closely concurring with these have been subsequently obtained by other experimenters; thus O. A. Crampton † found for various samples of lard, lard stearine, beef fat, oleostearine, cotton seed oil, and olive oil, coefficients of expansion between 15° and 100° lying between .000715 and .000797, averaging close to .00075. Since the relative density at $\frac{15^\circ}{4^\circ}$ of these substances was found to lie between .9065 and .9220, the average decrement in density per 1° C. rise in temperature was close to 0.69 on the thousandfold scale. W. T. Wenzell ‡ found that olive oil, mustard seed oil, castor oil, sperm oil, and cod liver oil expanded to almost exactly the same extent in each case between 16°.7 and 44°.4 C. (62° and 112° F.); the increment in bulk being 2 per cent., all the substances being examined in the same dilatometer. This represents an apparent coefficient of expansion per 1° C. of .00072, which, when corrected for the expansion of the glass, becomes .00075, or practically the same figure as that found by Crampton; and indicating an average decrement in density per 1° C. rise in temperature of 0.68 to 0.69. On the other hand, Lohmann states § that 1,000 volumes of olive oil increase

* *Commercial Organic Analysis*, vol. ii., p. 17, *et seq.* The values at the higher temperatures were mostly obtained by a plummet apparatus (Westphal's hydrostatic balance), and not corrected for the expansion of the glass plummet used, the object being simply to make comparative estimations; hence many of the figures in the last column are somewhat too low by about .01 to .02 (*vide* p. 77).

† *Journ. Soc. Chem. Ind.*, 1889, p. 550; from *Amer. Chem. J.*, 11., p. 232.

‡ *Analyst*, 1890, p. 14.

§ Schädler's *Technologie der Fette und Oele*, 2nd edition, edited by Lohmann, p. 91.

by 0·83 volumes for 1° C. rise of temperature; whilst the analogous increment for rape oil is 0·89, and for train oil, 1·00; figures perceptibly higher than those found by the other observers above mentioned.

VISCOSIMETRY.

In order to obtain valuations of the so-called "viscosity" of oils, &c., as approximate measurements of their relative lubricating powers, two classes of methods are in use—viz., those where the measurements are made by observing the mechanical effects produced by applying the oil, &c., between two conveniently arranged surfaces in motion with respect to one another; and those where the oil to be examined is made to pass through a given tube or orifice, and the time of passage of a known quantity is noted. From the practical point of view, obviously the most valuable measurements of the kind are those obtainable by imitating as nearly as possible the conditions under which the lubricant is to be used—i.e., the power of overcoming friction is best measured by a testing machine precisely similar to that for which the lubricant is required; quick moving spindles, rapidly revolving axles in journal boxes, or heavy slow moving shafting, &c., being employed as occasion requires. Such measurements, however, can only be properly carried out in comparatively large establishments, and are not at all adapted for use in laboratories where the chemical nature of the oils is investigated and their general characters tested; accordingly, in these cases, methods of the second kind are now usually employed, since experience has shown that the comparatively small sized mechanical testing machines of various kinds that have been invented for the purpose are apt to give results more discordant amongst themselves, and less faithfully representing the actual lubricating values of the substances examined, than those obtained by apparatus for the determination of "efflux velocity" (incorrectly designated "viscosity").

Of the numerous simpler forms of mechanical testing arrangements that have been proposed, one of the earliest (M'Naught's pendulum machine) is also one of the least unsatisfactory; this consists of two discs, the lower one provided with a raised edge and attached to a vertical spindle revolving in bearings, the upper one resting on a pivot. The space between the two discs is filled with the oil to be tested, and the lower one made to revolve at a given speed. The friction due to the oil would in time cause the upper disc to revolve too; but this motion is prevented by means of a projecting pin in contact with a pendulum. In consequence, more or less pressure on the pendulum is produced, diverting it from a vertical position; the degree of displacement affords a measure of the resistance of the oil.

Efflux Method.—The simplest arrangement for making comparisons between different oils, &c., as regards their efflux velocities, consists of an ordinary pipette filled up to a given mark on the stem with the oil to be tested, the time being noted requisite for the oil to run out either completely, or down to some lower mark. Fig. 16 represents an instrument on this principle devised by Schübler, the upper part of the pipette being expanded into a reservoir, with a scale attached indicating the level to which the fluid sinks; for comparative observations, the reservoir is filled to a given level, and the time determined during which the level sinks to a given extent, (a) in the case of the substance tested, (b) in the case of some other substance taken as standard.

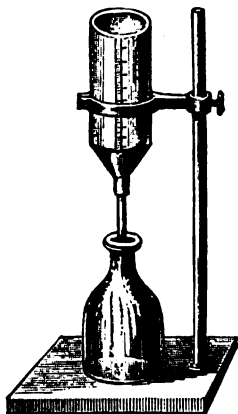

Fig. 16.

The time ratio thus deduced does not represent the relative time for *equal weights*, but that for *equal volumes*; so that to deduce the ratio for equal weights the value $\frac{t_1}{t_2}$ must be multiplied

by $\frac{d_2}{d_1}$, where d_1 is the relative density of the substance examined, and d_2 that of the standard substance. Thus if the substances contrasted were sperm and rape oils, and the respective times requisite for the same volume to flow out were 40 and 120 seconds, whilst the relative densities were .880 and .915 respectively, the relative efflux rate for equal weights would be

$$\frac{t_1}{t_2} \times \frac{d_2}{d_1} = \frac{40 \times .915}{120 \times .880} = .347.$$

As the time of efflux varies markedly with the temperature (usually diminishing as the temperature rises), such comparisons must necessarily be made under constant conditions as to temperature.

In order to ensure uniformity of temperature in different experiments the results of which are to be compared together, the vessel containing the oil may be conveniently surrounded with a jacket containing water or melted paraffin wax. Fig. 17 represents an arrangement of the kind described by E. Schmid, also containing a device for maintaining a constant pressure during the outflow, instead of having a continually varying "head," as in Schübler's instrument. The vessel containing the oil, A, is a sort of pipette, excepting that the upper end consists

of a tube, B, passing down inwards to a point, F, near the base of the expanded part. The upper end of B is closed by a stopper,

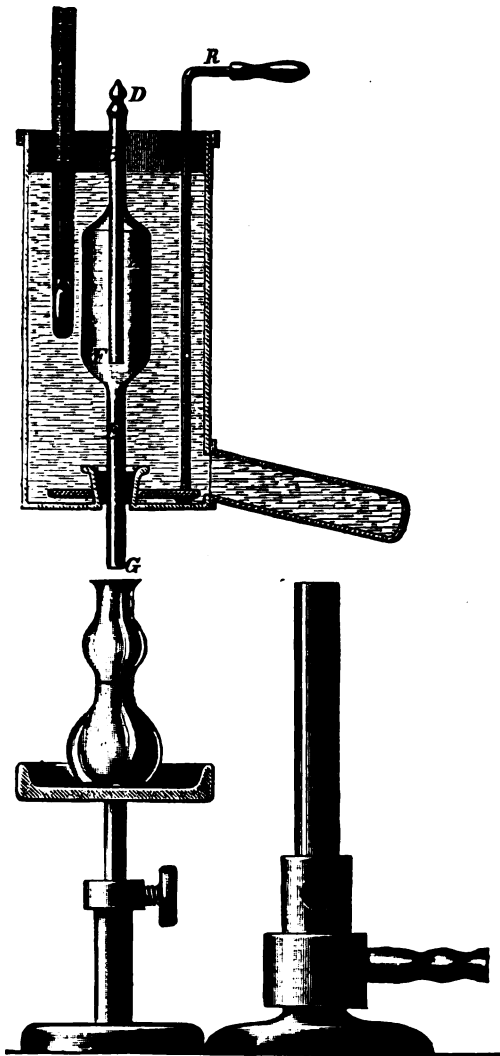

Fig. 17.

D, so that when the stopper is in, no air can enter, and, consequently, no oil runs out at G; but on removing the stopper the

oil flows out. The pipette is filled by removing the stopper, inverting it with the end BD immersed in the oil, and sucking up at the other end, G, until full, when it contains some 50 c.cs. The stopper being replaced, the pipette is fixed in position inside the water jacket, heated to the required temperature in the ordinary way by means of the projecting tube; a stirrer, R, with an annular plate at the end is provided; by moving this up and down the temperature is equalised. When the required temperature is attained the stopper is withdrawn and the time ascertained requisite for a given volume of oil to run out; as long as the level of the oil in the pipette does not fall below F, the pressure or "head" under which the oil issues at G is mani-

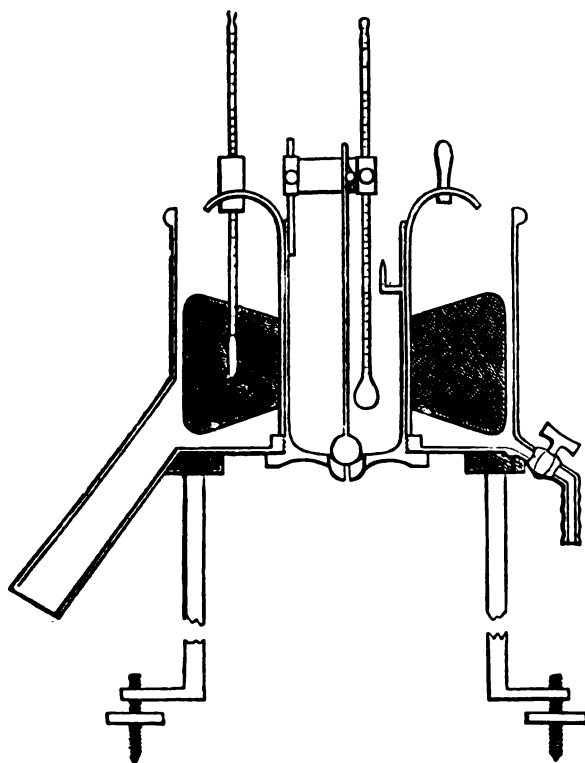

Fig. 18.

festly constant, being that due to a column of oil of length, GF. By employing high-boiling paraffin oils, &c., in the water jacket, the relative efflux times at high temperatures can thus be readily determined for various oils.

With all instruments of this description a variable amount of friction is brought into play as the oil passes through the efflux pipe, especially when this is conical; so that varying results are often obtained with different instruments. This source of error is best avoided by doing away with the efflux tube altogether, substituting for it a hole drilled in a plate of glass or agate.

Redwood's Efflux Viscosimeter.—Figs. 18 and 19 represent Boverton Redwood's form of viscosimeter, consisting of an interior silvered copper cylinder, about $1\frac{7}{8}$ ins. diameter and $3\frac{1}{2}$ ins. deep, containing the oil to be examined; the bottom of this is furnished with an orifice, consisting of a hole bored through an agate plate, the top of which is excavated into a hemispherical cavity, so that a small brass sphere attached to a rod and dropped in forms a sufficiently tight valve. An outer

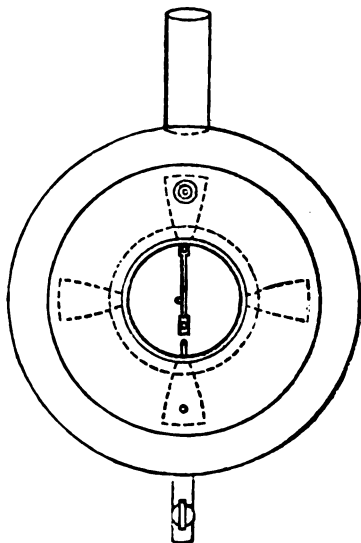

Fig. 19.

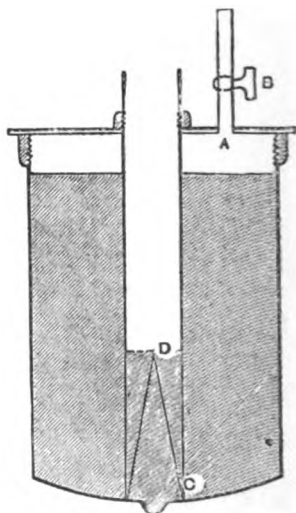

Fig. 20.

jacket is provided with a closed copper tube projecting therefrom downwards at an angle of 45° , so that by heating this "tail" in a Bunsen or spirit lamp flame, the temperature of the liquid (water, oil, melted paraffin wax, &c.) in the jacket can be raised as required. A revolving agitator to equalise temperature in the jacket is provided, with a thermometer attached, a second thermometer being supported in the oil by a clamp fixed to the cylinder. The whole rests on a tripod stand furnished with levelling screws. The constancy of initial level of oil inside the

cylinder is assured by means of a gauge consisting of a small internal bracket with upturned point.

When an observation is to be made the bath is filled with water, or heavy mineral oil, &c., and heated to the required temperature. The oil to be tested is also heated to this temperature and poured in until the level of the liquid just reaches the point of the gauge. A narrow-necked flask, holding 50 c.cs., is placed beneath the jet immersed in a liquid at the same temperature as the oil. When all is ready the ball-valve is raised and a stop-watch started, and the number of seconds requisite to fill

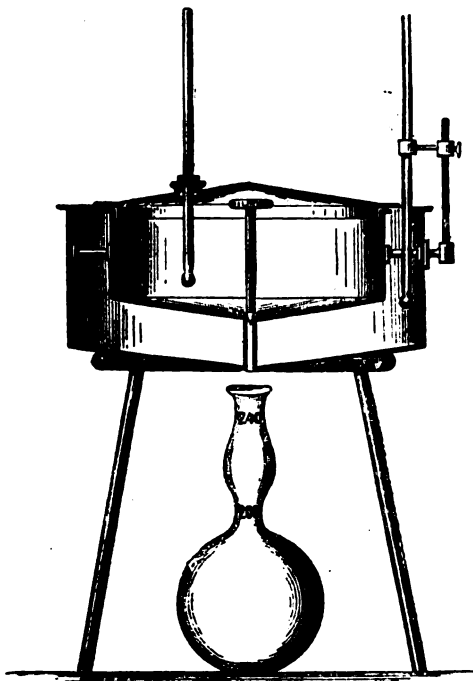

Fig. 21.

the 50-c.c. flask noted, care being taken that the temperature does not fluctuate during the time, and that the oil is perfectly free from suspended matter, such as dirt or globules of water.

In order to obviate the necessity of always using the same volume of oil (indispensable in order to end with the same difference of level, and consequently maintain the same average head or pressure throughout), A. H. Allen makes an addition

consisting of an airtight cover, Fig. 20, perforated by two holes, one of which, A, is furnished with a tap, B, while the other has another tube screwing airtight into it. This tube, C, is prolonged on two sides in contact with the agate orifice, whilst the angles of the inverted V-shaped slits cut on each side terminate at D, exactly $1\frac{1}{2}$ inches higher. The cylinder is completely filled with oil before commencing an observation, the tap, B, closed, and the orifice opened till the oil sinks to the level of D

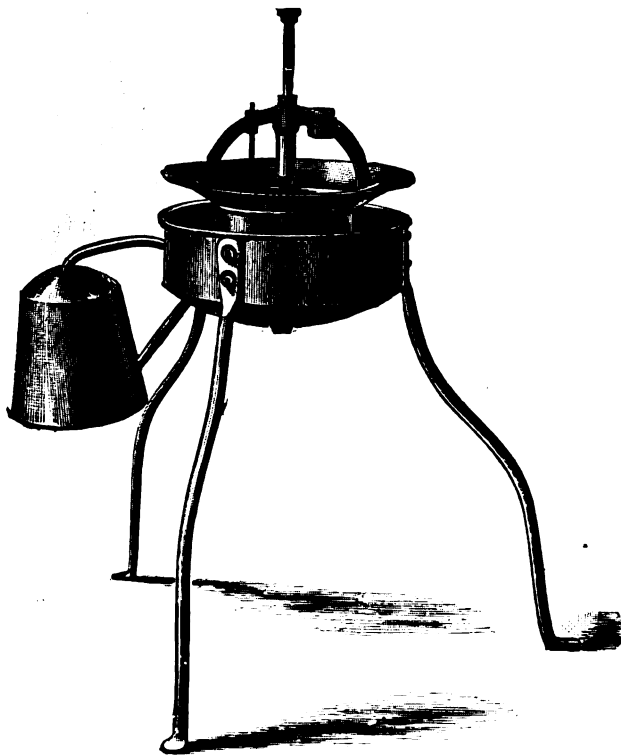

Fig. 22.

in the inner tube. Air then bubbles regularly in at D; when this happens, the temperature is noted and the oil collected in a graduated receiver. Any volume from 10 to 50 c.c. can thus be run out, as the oil falls in the upper part of the cylinder, but is maintained constantly at the level, D, in the inner tube. Five consecutive valuations of 10 c.c. each may thus be made, whilst 50 c.c. run out.

Several other forms of viscosimeter have been constructed by other experimenters, based on the efflux principle. Fig. 21 represents in section Engler's instrument; a slightly modified form of this by Engler and Künkler* is largely used on the continent.† Fig. 22 represents a simple form recently constructed by G. H. Hurst.‡ The oil, &c., to be examined is run into the innermost vessel up to a given height determined by a gauge-pin, and heated up to the required extent by applying a Bunsen burner or spirit lamp to the heater at the side, connected by two tubes with the water reservoir surrounding the oil chamber, so as to heat the water by circulation. The temperature of the oil is observed by means of a thermometer placed therein (usually this registers about 6° F. below the temperature of the water in the jacket); when the required temperature is reached, the central valve is raised, and 50 c.c. of oil allowed to run out into a measuring flask underneath, the time of efflux being noted. Obviously, with this instrument, the head under which the liquid issues is continually diminishing as it flows.

Standards of Efflux Viscosity.—In actual practice, water is too fluid to be a convenient standard substance; *rape oil* is usually chosen in preference, because, notwithstanding the unavoidable differences that exist between samples from seeds grown in different countries and soils, these differences are usually not extremely wide. Definite mixtures of pure glycerol and water, however, can be readily prepared, possessing almost any required higher degree of "viscosity,"§ and capable of use as standards of comparison of considerably greater uniformity, when prepared by different operators at different times, than is possible with natural products such as rape oil.

The following tables are selected from the numerous results published by various authorities, as illustrating the general character of the numbers obtained with "viscosimeters" of different kinds for determining the relative efflux rates of different natural oils, &c., and lubricants made therefrom, or from petroleum and other hydrocarbons, and the effect of variations of temperature on the values. The figures obtained by

* *Journ. Soc. Chem. Industry*, 1890, p. 654; from *Dingler's polyt. Journ.*, 276, p. 42.

† A still more recent form is described by Engler, with special instructions for its use (*Journ. Soc. Chem. Ind.*, 1893, p. 291; from *Zeits. ang. Chem.*, 1892, p. 725).

‡ *Journ. Soc. Chem. Industry*, 1892, p. 418.

§ With the viscosimeter above described, Boverton Redwood finds that the relative times requisite for 50 c.c. of water and genuine rape oil to flow out at the temperature of 15°·5 C. (60° F.) are 25·5 and 535 seconds respectively, taking the average of various samples of pure oil. A. H. Allen finds that glycerol diluted with water until the specific gravity at 15°·5 is 1·226, possesses the same degree of viscosity as average rape oil when tested in the same way.

Schübler represent the "viscosity degree" (*viscositätsgrad*) or "relative viscosity" of the respective oils—i.e., the relative times requisite for *equal volumes* to pass (at 7°·5 and 15° C. respectively), the times required by the same volume of water being taken as unity; those quoted from the other authorities are not thus reduced, but are simply the actual times directly observed with the particular instruments used:—

Name of Oil.	Relative Time in Seconds (Schübler).		
	Plant from which derived.	At 7°·5 C.	At 15°·0 C.
Castor oil,	<i>Ricinus communis</i> ,	377·0	203·0
Olive oil,	<i>Olea europæa</i> ,	31·5	21·6
Hazelnut oil,	<i>Corylus avellana</i> ,	24·2	18·4
Colza oil,	<i>Brassica campestris oleifera</i> ,	22·4	18·0
Rape oil,	<i>Brassica rapa oleifera biennis</i> ,	22·6	17·6
Beechnut oil,	<i>Fagus sylvatica</i> ,	26·3	17·5
White Mustard oil,	<i>Sinapis alba</i> ,	24·0	17·4
Almond oil,	<i>Amygdalus communis</i> ,	23·3	16·6
Spindlenut oil,	<i>Euonymus europæus</i> ,	23·3	15·9
Black mustard seed oil,	<i>Sinapis nigra</i> ,	19·4	15·6
Poppy seed oil,	<i>Papaver somniferum</i> ,	18·3	13·6
Camelina seed oil,	<i>Myagrum sativum</i> ,	17·7	13·2
Belladonna seed oil,	<i>Atropa belladonna</i> ,	17·3	13·1
Sunflower oil,	<i>Helianthus annuus</i> ,	16·4	12·6
Turpentine oil,	<i>Pinus sylvestris</i> ,	16·7	11·8
Cress oil,	<i>Lepidium sativum</i> ,	14·4	11·4
Grape seed oil,	<i>Vitis vinifera</i> ,	14·2	11·0
Plum kernel oil,	<i>Prunus domestica</i> ,	14·7	10·3
Tobacco seed oil,	<i>Nicotiana tabacum</i> ,	13·5	10·0
Walnut oil,	<i>Juglans regia</i> ,	11·8	9·7
Linseed oil,	<i>Linum usitatissimum</i> ,	11·5	9·7
Hemp seed oil,	<i>Cannabis sativa</i> ,	11·9	9·6

Oils, &c., Used.	Relative Time in Seconds (Wilson).		
	At 15°·5 C. = 60° F.	At 40° C. = 104° F.	At 82° C. = 180° F.
Sperm oil,	47	30·5	25·75
Olive oil,	92	37·75	28·25
Lard oil,	96	38	28·5
Rape oil,	108	41·25	30
Neat's foot oil,	112	40·25	29·25
Tallow oil,	143	37	25
Engine tallow,	Solid.	41	26·5

VISCOSITY IN SECONDS FOR 50cc.

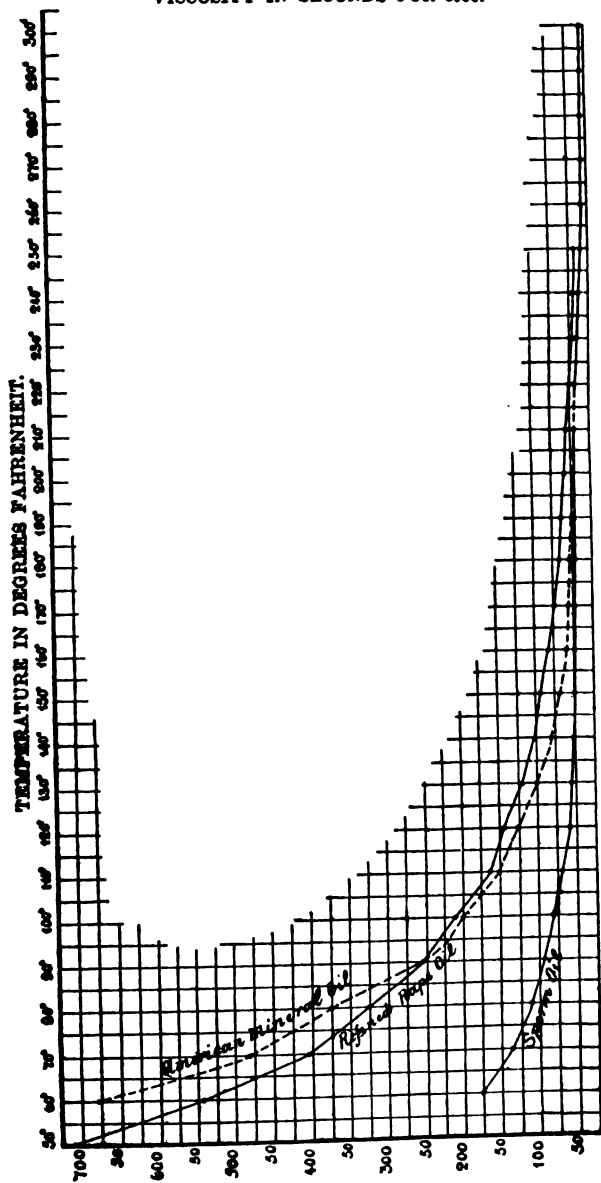

Fig. 23.

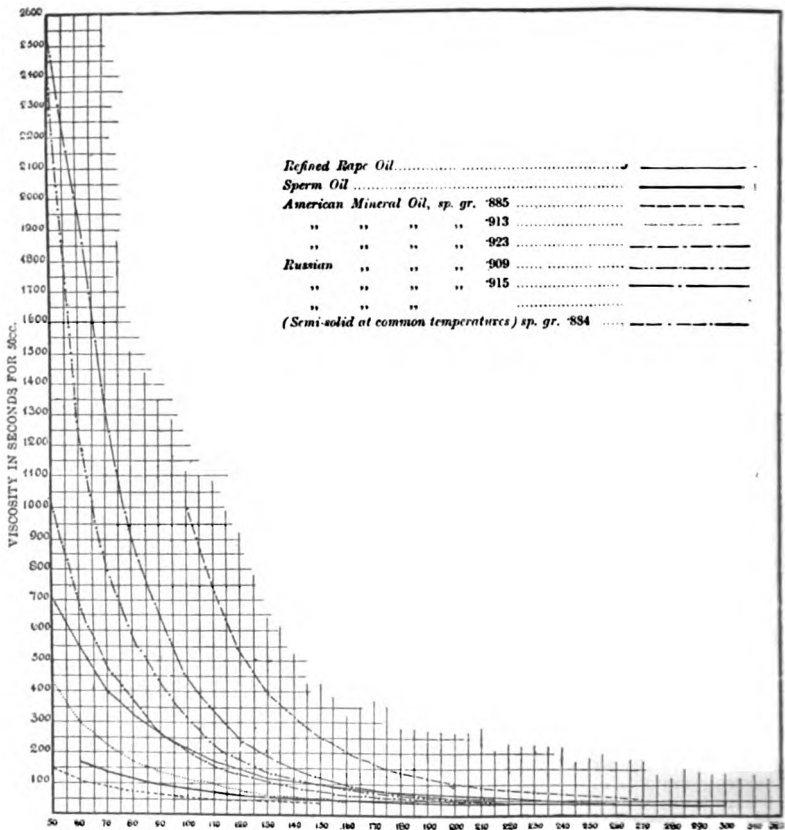

Fig. 24.—Temperature in Degrees Fahrenheit.

Oils Employed.	Relative Time in Seconds (Allen).			
	Spec. Grav. at 15° C.	At 15° C. = 60° F.	At 50° C. = 122° F.	At 100° C. = 212° F.
Sperm oil,881	80	47	38
Seal oil (pale),924	131	56	43
Northern whale oil,931	186	65	46
Menhaden oil,932	172	40	...
Sesamé oil,921	168	65	50
Arachis oil,922	180	64	...
Cotton seed oil (refined),925	180	62	40
Niger seed oil,927	176	59	43
Olive oil,916	187	62	43
Rape oil,915	261	80	45
Castor oil,965	2420	330	60

	Relative Time in Seconds (Redwood).						
	50° F.	70° F.	100° F.	140° F.	200° F.	250° F.	300° F.
Refined rape oil, No. 1,	712.5	405	147	105.5	58.5	43.25	...
" " 2,	...	406	146	106.5	57.5
" " 3,	...	405.5	147	106.5	57.5
" " 4,	...	407	147.5	106	58.5
Beef tallow,	54.75	40	...
Sperm oil,	136.8	60.5	50.75	42	34.75	30
Neat's foot oil,	620	366	126	88.4	50.4	44	38
American mineral oil, } specific gravity, .885	145	90	47	41
American mineral oil, } specific gravity, .923	1,030	485	126	82	42
Russian mineral oil, } specific gravity, .909	2,040	820	174	116	48.5
Russian mineral oil, } semisolid,	531	317.5	99.25	59.25	42.6

Redwood's results are indicated graphically by the curves indicated in Figs. 23 and 24.

	Relative Time in Seconds (Hurst).				
	70° F.	100° F.	120° F.	150° F.	180° F.
Castor oil,	1,248	487.5	201.5	91	48
Thickened rape oil,	1,370	331.5	279.5	156	78.5
Sperm oil,	58.5	36.4	26	19.5	17
Colza oil,	131	56	44	32.5	28
Whale oil,	128.7	61	44	28.5	28
Tallow oil,	105	63	45	30	20
Cotton oil,	100	55	40	25	20
American 885 oil,	68	3.5	23	15	14
American 905 oil,	113	44	32.5	19.5	18
American 915 oil,	140	47	36	21	19.5
Scotch 865 oil,	32.5	22	18	15.5	13
Scotch 885 oil,	58.5	26	22	18	15.5
Scotch 890 oil,	71.5	39	26	19.5	17
Russian 906 oil,	292.5	97.5	56	30	22
Russian 911 oil,	462	143	91	82.5	26
Rosin oil, dark,	152.5	97.5	38	22	18
Rosin oil, pale,	136.5	49.4	25	18	17
Cylinder oil, medium,	385	255	170	70
Cylinder oil, pale,	405	265	120	90
Cylinder oil, dark,	890	495	230	100

As further illustration of the effect of rise of temperature in diminishing the rate of efflux, the following figures may also be

quoted, obtained by Villavecchia and Fabris, whilst investigating certain lubricating oils* for excise purposes:—

Lubricating oil.	Efflux Rate referred to Water at	
	At 20° C.	At 50° C.
No. 1	44.39	6.81
„ 2	51.07	5.94
„ 3	40.85	5.50
„ 4	38.77	6.03
„ 5	72.09	8.35
„ 6	67.92	9.66
„ 7	56.03	5.71

Thus, the effect of a rise in temperature from 20° to 50° is to diminish the efflux rate to $\frac{1}{3}$ - $\frac{1}{10}$ of the original value, the effect being more marked with the more viscous fluids.

According to experiments by Bender,† when an oil is chilled to - 20° for some time, and then warmed up again, the efflux viscosity value at the ordinary temperature is often considerably increased as compared with what it was previously at the same temperature of observation, thick oils usually showing a greater increment than thinner ones. On the other hand, if oils are heated up to 50° or 100°, and then allowed to cool down again to the air temperature, the thicker oils become perceptibly thinner, whilst the thinner oils are less affected.

Lepenau's Leptometer.—This instrument is based on a principle somewhat different from that involved in the above described forms of efflux viscosimeter, inasmuch as it depends not only on the rate of flow through a given orifice, but also on the amount of surface tension called into play when drops are formed in air. It consists essentially of a pair of precisely similar cylinders, B B (Fig. 25), immersed in the same bath, A, one of which contains the oil to be examined, and the other another oil used as standard of comparison; the relative rates are noted at which drops form as the oil passes through equal sized capillary tubes, r, r , the dimensions of which are too small to permit of continuous streams being produced, the quantities flowing out in a given time being weighed or measured.

All these various forms of instrument are subject to one constant source of error—viz., that the forces coming into play

* "Report of the Central Laboratory of the Italian Customs' Department, 1891; also *Journ. Soc. Chem. Industry*, 1891, p. 390.

† *Journ. Soc. Chem. Industry*, 1891, p. 936; from *Mitth. König. techn. Versuchsanst., Berlin*, 1891, p. 100.

when a viscous liquid passes through a tube or orifice under given conditions of temperature, &c., are not the same as those obtaining when the liquid is used as a lubricant for shafting, quickly rotating spindles, axles, and the like; and, consequently, that the figures obtained by means of such testing appliances are only approximations (and not always close ones) to the relative values of the substances examined, when practically applied for lubricating purposes.

Determination of Viscosity in Absolute Measure.—When liquids are examined possessing a comparatively low degree of viscous character, the rate of flow through a narrow orifice does not represent the true physical “viscosity,” because a large proportion of the result is due to flow pure and simple without any “shear;” accordingly, when a comparatively long narrow accurately calibrated tube is made use of as the jet, figures are obtained not always showing close agreement with those yielded by the ordinary forms of efflux apparatus.

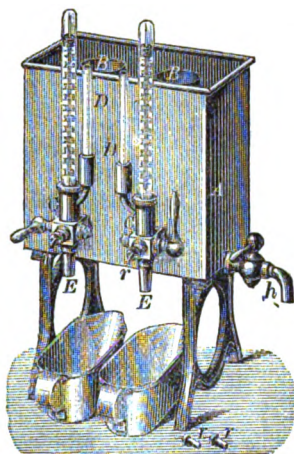

Fig. 25.

According to mathematical investigations by Poiseuille and others, the coefficient of friction in narrow tubes is given by the formula

$$\eta = \frac{\pi pr^4 t}{svl},$$

where η is the coefficient of friction, t the time of efflux, v the volume of fluid discharged, p the hydraulic pressure, l the length and r the radius of the capillary tube, and s the specific gravity of the liquid.* Starting from this, E. J. Mills has made some measurements in absolute measure of the coefficients of friction for various liquids, including water, and sperm, olive, lard, and castor oils.†

On the C.G.S. system (centimetre, gramme, and second as units of length, mass, and time respectively) Poiseuille's formula becomes

$$= \frac{\pi pr^4 t}{svl} \times 98.1,$$

* Hagenbach arrives at a formula involving a second term in addition to that given by Poiseuille—

$$\eta = \frac{\pi pr^4 t}{svl} - \frac{vs}{2^{1/2} \pi l t}.$$

† *Journ. Soc. Chem. Ind.*, 1886, p. 148; also, 1887, p. 414.

where v is given in cubic millimetres, and r , l , and p in millimetres; from this formula and his experimental results, Mills deduces the following values at 12° C. :—

	Specific Gravity.	Value of η .	Relative Viscosity. Water = 1.
Water,	1·000	·011713	1·00
Sperm oil,	·88789	·68828	58·76
Olive oil,	·92043	1·1393	97·27
Lard oil,	·92051	1·6285	139·03
Castor oil,	·96541	21·721	1854·4

Obviously these relative viscosity values are very dissimilar from Schübler's numbers for castor and olive oils compared with water, although the ratios between the values for the oils alone do not differ so widely in the two cases; this chiefly arises

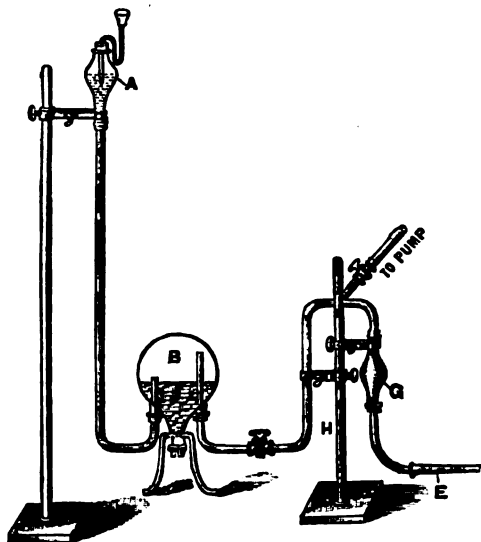

Fig. 26.

from the error attaching to the viscosity determination in the case of water by the efflux method through a jet, as compared with the true value through a long narrow tube.*

* The determinations of absolute "viscosity" values of solutions of gum relatively to water made by noting the times required for given volumes to pass through a known capillary tube, show similar differences when compared with the corresponding values obtained with a "jet" apparatus, such as a burette (*vide* paper by S. Rideal, *Journ. Soc. Chem. Ind.*, 1891, p. 610).

Coefficient of Friction in Capillary Tubes.—Traube has constructed an arrangement for determining with considerable accuracy and speed the friction coefficients for oils and other liquids passing through capillary tubes under pressure. Fig. 26 represents this apparatus.* A is a Mariotte bottle filled with water, which serves to compress air in the reservoir B, and to keep the pressure constant; B is connected by means of a pipe and cock to the efflux apparatus H, consisting of the bulb G (provided with two marks to permit the measurement of volume of liquid to be discharged) and the capillary tube E. The reservoir B is filled by means of a pump attached to branch and stopcock. When the observations are to be made at temperatures above that of the atmosphere a suitable airbath is employed. When required to be cleaned, ether is forced through the tube. With tubes of different diameters, the relative times observed for water and oils of high viscosities are not identical; but for oils of considerable viscosity the differences are not great; thus, the following figures were observed with a cylinder lubricating oil and with olive oil as compared with rape seed oil, being the respective times of efflux in seconds:—

Diameter of tube in millimetres, }	1·5	0·8	0·5
Cylinder oil,	155·5 = 100·0	472 = 100·0	2960 = 100 0
Rape seed oil,	79·0 = 50·8	242 = 51·3	1503 = 50·8
Olive oil,	71·7 = 46·1	222 = 47·0	1364 = 46·1

In all probability the conditions existing when oil is forced through a capillary tube are more nearly akin to those obtaining with a film of oil lying between a shaft and its journal box than are those subsisting in the ordinary forms of efflux viscosimeter; and hence it is probable that the results of valuations on Traube's system would be valuable as determinations more closely approximating to the actual practical lubricative values. Traube's apparatus, however, is far less convenient for ordinary laboratory work than Redwood's or Engler's viscosimeter.

* *Journ. Soc. Chem. Ind.*, 1887, p. 414.

§ 3. Chemical Properties of Oils, Fats, Butters, and Waxes.

CHAPTER VI.

PROXIMATE CONSTITUENTS AND THE METHODS USED FOR THEIR EXAMINATION AND DETERMINATION.

VERY few, if any, natural oils, fats, and waxes consist of one single chemical substance; almost invariably two, and often many more constituents are present, the most marked distinction between which is that some are solid at the ordinary temperature (when obtained separate), others liquid; the former often deposit in the solid form on chilling, so that a fluid oil, when chilled and pressed, yields a solid so-called "stearine" and a liquid so-called "oleine"* as first proximate constituents. In similar fashion semisolid butters and hard fats, like tallow, can be shown to contain a solid and a liquid constituent in each case, the consistency of the material, roughly speaking, depending simply on the relative proportions of the two substances. When "oleine" largely predominates the substance is an oil; when "stearine," a hard fat; and when the two are in intermediate

* The terms "stearine" and "oleine" are practically employed in several different senses, a circumstance apt to lead to considerable confusion. In the strict chemical sense, stearine is the glyceride of stearic acid, $C_3H_5(O.C_{18}H_{33}O)_3$, and oleine the glyceride of oleic acid, $C_3H_5(O.C_{18}H_{33}O)_3$; but in the oil trade generally the two terms are applied to indicate respectively the solid and liquid constituents into which a fat or chilled oil can be mechanically separated, irrespective of the actual chemical composition of these constituents; whilst in the candle manufacture they are used to denote the analogous solid and liquid fatty acids obtainable from fatty matters by saponification and mechanical pressure, &c. Similar mixtures of free fatty acids and other substances are also obtainable by subjecting to distillation various kinds of grease (*e.g.*, Yorkshire grease—Chap. XII.); when these are chilled and pressed they are separable into solid and liquid portions, generally designated as "distilled" stearine and oleine respectively. In the present work the pure chemical triglycerides are distinguished by the terminal "in" (*e.g.*, *stearin*, *olein*, &c.); whilst the commercial articles are indicated by names ending in "ine" (*e.g.*, "*distilled*" *oleine*, *candlemakers' stearine*, *oleomargarine*, &c.). In similar fashion, the pure chemical compound $C_3H_5(OH)_3$ is referred to as "glycerol," whilst the commercial products mainly consisting of this body, but in a varying state of purity, are distinguished as *glycerine* (*vide p. 8*).

proportions, a more or less buttery consistence is possessed at the ordinary temperature (near 15° C.)

The further investigation of the solid and liquid constituents thus obtainable from a given oil or fat ; of the variations in their relative proportions and natures according to the soil and climate and other conditions under which the plant was grown in the case of vegetable oils or butter, or the species and habitat of the animal in that of an animal oil or fat ; of the effect of cultivation and domestication, and various similar points, have hitherto received but little attention. There appears, however, to be some reason for supposing that very considerable differences in the relative amounts and even in the chemical nature of the various constituents of a given oil, &c., may, at any rate in some cases, be brought about by such causes ; thus, very different results have been found by various experimenters who have examined different samples of the same kind of oil—*e.g.*, in the case of arachis oil (groundnut oil), where several successive chemists have succeeded in isolating considerable amounts of *hypogæic acid* for the purpose of studying that substance and its derivatives, whilst more than one other chemist has found either none at all, or practically none, in the oil examined by him ; and where, moreover, some observers have found more or less considerable amounts of *palmitic acid*, and others none at all. Similar discrepancies in the results obtained by different investigators have been noticed in several other instances, thus leading to the conclusion that marked differences are apt to exist in the nature of oils and fats prepared from seeds, &c., grown under different conditions, just as is well known to be the case with fruits and other vegetable produce, as regards the saccharine matter and other constituents present therein. Even without taking into account these natural variations, however, the knowledge at present extant of the proximate constituents of many of the more commonly occurring oily and fatty matters is decidedly scanty ; whilst a very large number of similar substances exist (in many cases of great local importance, although not always materials largely exported or imported or otherwise dealt with commercially) concerning the general composition of which accurate knowledge is hitherto entirely wanting. Many such products promise in the near future to be important articles of trade, as soon as their respective values for particular purposes are better ascertained, and the best means to be adopted of extracting and refining them so as to render them marketable ; in Central and Southern Africa, and in many other parts of the world, the progress of civilisation is continually tending to bring into notice new products of this kind, many of which only require attention being called to them to demonstrate their commercial value.

The separation from one another of the different glycerides,

&c., contained in a given "stearine" or "oleine" is, in most cases, a very difficult problem, more especially if required to be performed in such a fashion as to give an approximate idea of the relative proportions in which they are present. As a rule, the best results are obtained by saponifying the mixture, and applying methods for the separation of the resulting fatty acids, either by mechanical means (chilling and pressing out the more liquid portions) or by chemical processes. For example, the lead salt of oleic acid is soluble in ether, whilst lead stearate, palmitate, &c., are practically insoluble in that medium; so that by converting into lead salts the mixture of free fatty acids obtained on saponification and acidulation, and treating the mixture with ether, a partial separation may be effected, lead oleate with comparatively small quantities of stearate, palmitate, &c., being dissolved out, and lead stearate, palmitate, &c., with small quantities of adhering oleate being left. With a mixture of solid fatty acids (palmitic, stearic, arachic, &c.), fractional crystallisation from alcohol of the mixed free acids; fractional precipitation as insoluble salts (of lead, magnesium, &c.); fractional crystallisation of certain salts (*e.g.*, magnesium salt) from alcohol or other appropriate menstruum; and similar processes are applicable in various cases; but the complete examination of mixtures of fatty acids in this way is so laborious, that it has been thoroughly carried out in but very few instances. In the case of fractional precipitation, as a general rule, the acid of higher molecular weight precipitates first; thus, with a mixture of arachic, stearic, and palmitic acids in approximately equal proportions, precipitated as salts in several fractions, the first fraction will be chiefly a salt of arachic acid, and the last will contain little besides palmitate.

Some oils and fats contain appreciable quantities of the glycerides of acids of sufficiently low molecular weight to be volatile along with the vapour of water at the ordinary atmospheric pressure. In such a case, after saponification and acidulation, an acid distillate is obtainable by boiling, preferably by blowing through the mass a current of steam from a suitable generator. The weakly acid aqueous fluid may then be neutralised with an alkali, evaporated to a small bulk, and decomposed by a mineral acid; or converted into silver or barium salts, &c., and further examined. If more than one volatile acid be present, a separation may often be effected by fractional precipitation as silver salt, &c.; or enough mineral acid may be added to liberate a fraction of the total organic acids from the evaporated solution of alkaline salts, and the distillation repeated; the acid of lowest molecular weight will then pass over. By similarly liberating successive fractions and distilling alternately, a series of distillates will be obtained, the acids of higher molecular weight being contained in the respective later fractions (Liebig).

When a mixture of acids volatile with steam and others not volatile therewith is present, if, instead of blowing steam through the whole mass, the insoluble fatty acids be allowed to float up in a fused condition, and are then removed (after cooling and solidifying), the remaining aqueous liquor is often found to yield perceptibly less volatile acid, a portion having been dissolved by the insoluble acids, much as ether dissolves out various substances from aqueous solution when agitated therewith. In consequence of this, it is often impossible to obtain a constant weight of the insoluble fatty acids thus obtained on drying at 100°, unless they have been repeatedly treated with boiling water, so as to remove soluble constituents (*vide* Chap. VIII., "Hehner Number"); otherwise, the small quantity of volatile acid present slowly evaporates, giving a continual small loss. In some cases, this by and by becomes balanced by gain in weight through oxidation (by spontaneous absorption of oxygen from the air), and later on still the gain from this cause predominates.

By means of superheated steam the fatty acids of higher molecular weight may be pretty readily distilled; but anything like a complete separation of closely related homologous acids (*e.g.*, myristic, palmitic, and stearic acids) in this way by processes of fractional distillation is difficult, if not impossible; and the same remark applies to distillation under greatly diminished pressure (in a partial vacuum). In some cases fractional saturation with alkali, &c., of a mixture of acids will cause a more or less complete separation, one combining with the base to the exclusion of the other: more often the base becomes shared between the two in proportions depending on the relative masses present. Thus Thum found* that when a mixture of equal weights of stearic and oleic acids is dissolved in hot alcohol and treated with a quantity of alcoholic potash sufficient to saturate only one half of the total acids, a mixed soap is obtained, which (when separated from the uncombined excess of fatty acids by means of petroleum ether) consists substantially of equal quantities of potassium stearate and oleate; the free acids similarly consisting of stearic and oleic acids in sensibly the same proportion.†

A good deal still remains to be done in the case of a considerable number of vegetable oils in the way of identifying and quantitatively estimating their various proximate constituents; and much the same remarks apply to certain animal oils, more especially "train oils" from marine cetaceans, as regards not only the acids present but also the alcoholiform constituents;

* *Zeitsch. f. angew. Chemie*, 1890, p. 482.

† A similar state of matters is observed when a given fatty acid acts on a mixture of caustic potash and caustic soda; both potash and soda soaps result in proportions sensibly near to those in which the two alkalies are present in the mixture; and not one kind of soap to the exclusion of the other (*vide* Chap. XXI.)

whilst it is known that certain of these oils are mainly composed of compound ethers of non-glyceridic character, which furnish on saponification acids mostly of the oleic family, and as complementary products, alcohols of moderately high molecular weight (e.g., *dodecattylic alcohol*, $C_{12}H_{26}O$, from Doegling oil), the complete investigation of the products thus formed has been attempted in very few instances indeed, and much still remains to be done in this field; it appears, however, that besides alcohols of the ethylic series, others of a non-saturated character are also present in some of these oils, as the alcoholiform constituents extracted are in many cases capable of combining with iodine, leading to the conclusion that higher acrylic alcohols are also contained as compound ethers in addition to cetylic alcohol homologues.

Free Fatty Acids and Higher Alcohols contained in Natural Oils and Fats, &c.—Owing to the presence of mucilaginous, albuminous, or gelatinous matters in most crude vegetable oils expressed from seeds, or animal fats and oils obtained from animal tissues, it generally happens that a perceptible amount of hydrolysis of glycerides is brought about in the process of extraction, due to the influence of these substances and the fermentative changes rapidly undergone by them; even when solvents (such as light petroleum oil, carbon disulphide, or ether) are used for the isolation of the oil, &c., it not unfrequently happens that measurable amounts of free fatty acids are contained in the product obtained; leading to the conclusion that hydrolytic actions naturally take place to a greater or lesser extent in the seeds, tissues, &c., during crushing and analogous operations, or even on simply keeping, so that small quantities of free acids are practically always present in the natural products as obtained on a manufacturing scale from the animal after death, or from the seed after detaching from the plant, even when not normally present in the living animal or growing vegetable. The extent to which actions of this sort take place is extremely variable; in general the "cold drawn" oils expressed from seeds, and the corresponding first runnings from fresh fish livers, and the more liquid "oleomargarine," obtained by the action of gentle heat on animal fats, contain much smaller proportions of free fatty acids than the later fractions obtained by subsequent hot pressing and analogous operations; whilst in the case of vegetable oils the maximum amounts of free fatty acids are contained in the oils extracted by solvents from oilcakes, and in those obtained from vegetable pulps (pounded nuts, crushed olives, and such like) by heating with water so that oily matter floats up, separated by skimming—i.e., in those cases where contact with fermentible matters has been most intimate and prolonged. Thus, the following figures were obtained by Noerdlinger,* the total fatty matter being

* *Journ., Soc. Chem. Ind.*, 1890, p. 422, from *Zeit. Anal. Chem.*, 29, p. 6.

extracted from the seeds by means of light petroleum spirit, and the free fatty acid (determined by titration with phenolphthalein as indicator) reckoned as oleic acid (*vide* p. 117):—

Oils.	101 Parts contain		Free Fatty Acids Reckoned per 100 of Total Fat.
	Free Fatty Acids.	Total Fat.	
Rape (<i>Brassica rapa</i>),	0·42	37·75	1·10
Cabbage (<i>B. campestris</i>),	0·32	41·22	0·77
Poppy (<i>Papaver somniferum</i>),	3·20	46·90	6·66
Earthnut (<i>Arachis hypogæa</i>) seed,	1·91	46·09	4·15
Earthnut (<i>Arachis hypogæa</i>) outside pale husk,	1·91	4·43	43·10
Sesamé (<i>Sesamum orientale</i>),	2·21	51·59	4·59
Castor (<i>Ricinus communis</i>),	1·21	46·32	2·52
Palmnut (<i>Elaeis guineensis</i>) containing 6 per cent. husks,	4·19	49·16	8·53
Cokernut (<i>Cocos nucifera</i>),	2·98	67·40	4·42
Oil Cakes.			
Rape,	0·93	8·81	10·55
Poppy,	5·66	9·63	58·89
Earthnut,	1·42	7·65	18·62
Sesamé,	6·15	15·44	40·29
Palmnut,	1·47	10·39	14·28
Cokernut,	1·31	13·11	10·51
Linseed,	0·75	8·81	9·75
Castor,	1·27	6·53	20·07

Obviously, when oil contains any considerable quantity of free fatty acids the use of alkaline refining processes (Chap. XI.) is apt to lead to a considerable diminution in the quantity of refined product obtained, as compared with the raw material employed, because the free fatty acids are removed in the form of soaps, the production of which, moreover, often leads to further loss by the mechanical entangling of "neutral" oil in the saponaceous "foots."

The presence of free fatty acids in any quantity in most kinds of oils is detrimental to their value, more especially in reference to certain applications. Thus, in the case of lubricating oils, corrosion of bearings, &c., is more apt to be brought about when free fatty acids are present than when the oil is practically free therefrom; and hence in such cases alkaline refining processes will often give a superior result, the more so that acid processes are apt to communicate to oil refined thereby traces of mineral acid, the corrosive action of which is still more marked. This is notably the case with oils intended for wool spinning and

analogous purposes. Colza oil containing much free fatty acids burns less freely, and is more apt to char the wick than comparatively neutral oil. On the other hand, the taste of olive oil is said to be considerably improved by the presence therein of small quantities of free acids; whilst largely hydrolysed oils (*huiles tournantes*) are intentionally prepared for certain special purposes in the textile and dyeing industries.

In the case of blubber oils largely consisting of the compound ethers of higher monatomic alcohols of the ethylic series, the hydrolytic actions taking place during storage before and after extraction, and whilst the "rendering" is taking place, lead to another result—viz., that cetylic alcohol and analogous bodies are largely contained in the oils ultimately obtained; thus, from 30 to 40 per cent., and sometimes more, of so-called "unsaponifiable matter" is frequently found to be present in sperm and other blubber oils, chiefly consisting of alcoholiform products of hydrolytic actions of this description. Similar remarks apply to beeswax, and to the various vegetable waxes of analogous constitution; figures are on record, obtained by various analysts, indicating in extreme cases that from $\frac{1}{2}$ to $\frac{2}{3}$ of the original compound ethers have been hydrolysed by actions of this description, either occurring naturally during storage, or in consequence of the processes adopted in preparing the raw material.

DETERMINATION OF FREE FATTY ACIDS. FREE ACID NUMBER.

The most accurate process for determining the amount of free acids contained in a given sample of oil or fat, consists in agitating it with warm alcohol, and dropping in a standard alkaline solution (preferably alcoholic) until a persistent pink coloration appears after continued agitation, phenolphthalein being the indicator; the temperature must be high enough to render the fat perfectly fluid. Or the oil may be dissolved in cold ether, mixed with a little alcohol, and the solution titrated with standard alcoholic alkali. If the mean equivalent weight of the free fatty acids is known (or assumed) to be E , the proportion of fatty acids in the free state is given by the formula,

$$x = \frac{E \times n}{w} \times 100,$$

where w is the weight in milligrammes of material taken for examination, n the number of c.c. of normal alkali used,* and x the weight of free fatty acids contained in 100 parts of substance (*percentage of free fatty acids*); for since 1 c.c. of normal

* If seminormal (or decinormal) alkali be used, the value of n will obviously be $\frac{1}{2}$ (or $\frac{1}{10}$) of the number of c.c. used, and so on.

alkali represents E milligrammes of fatty acids, the total weight of acids contained in w milligrammes of substance is $n \times E$ milligrammes, whence 100 parts of substance contain $\frac{E \times n}{w} \times 100$ parts of free fatty acids.

In many instances the value of E is not known accurately, and in such cases it is more convenient to express the amount of fatty acids in terms of the alkali neutralised. This may be done with respect to 100 parts of original substance, thus giving the *percentage of potash (or soda) neutralised*, according to the alkali employed; but a more usual practice is to express the value relatively to 1,000 parts of original substance, potash (caustic potash, KOH, equivalent 56.1), being selected as the alkali, thus giving the *permillage of potash neutralised*, conveniently referred to as the "free acidity potash permillage," or "free acid neutralisation number," or, more shortly, as the "free acid number," and expressed by the value $\frac{n}{w} \times 56,100$.*

Thus, suppose that 10 grammes (10,000 milligrammes) of palm butter neutralise 8 c.c. of seminormal alkali, equivalent to 4.0 c.c. of normal alkali; since 1 c.c. of normal alkali corresponds with 56.1 milligrammes of KOH, and with 256 milligrammes of palmitic acid (*i.e.*, $E = 256$), the result may be stated by saying that the "free acidity potash permillage" or "free acid number" is $\frac{4.0}{10,000} \times 56,100 = 22.44$; or it may be expressed in terms of percentage of palmitic acid by saying that the substance contains free acids jointly equivalent to $\frac{4.0 \times 256}{10,000} \times 100 = 10.24$ per cent. of palmitic acid.

When only small quantities of free acid are present, and extremely sharp valuations are desired, somewhat large quantities of material should be taken for the determination; 20 or 25 grammes, or even more. A less accurate method of determining free fatty acids consists in shaking up the oil, &c., with alcohol, allowing to stand, separating a known fraction of the alcoholic fluid, and titrating with standard alkali; the result is apt to be somewhat too low on account of incomplete solution of all free acid by the alcohol.

In some natural oils (*e.g.*, unrefined cotton seed oil) substances are present of an acid character, although not belonging to the

* Since 1 c.c. of normal alkali represents 56.1 milligrammes of KOH, n c.c. represent $n \times 56.1$ milligrammes: then if A be the free acid number as above defined,

$$w : n \times 56.1 :: 1,000 : A$$

$$\text{whence } A = \frac{n}{w} \times 56,100.$$

ordinary fatty acid series, but more resembling the acids of pine resin; these substances neutralise alkali (phenolphthalein being the indicator), and are consequently included in the total of "free fatty acids" determined by titration. Occasionally ordinary rosin (colophony) is intentionally added to oils or the fatty acids thence derived, either as an adulterant or for special reasons—*e.g.*, in the manufacture of some kinds of waggon grease and "yellow" soap. For the methods used in determining the amount of resin present in such cases, *vide* Chap. XXI.

When it is required to separate the free fatty acids from the neutral fat, this is readily accomplished by adding alcoholic alkali until just neutral to phenolphthalein, diluting with water, and agitating with ether, or better, with light petroleum spirit.* The ethereal liquid on evaporation leaves the neutral fatty matter, which can be weighed and further examined as desired: the aqueous fluid is acidulated and shaken with petroleum spirit, &c., whereby the free fatty acids are similarly obtained.

If mucilaginous matter, &c., is also present, the oil may be ground up in a dish with half its weight of solid sodium carbonate and as much water, and dried on the waterbath; the residue is again stirred up with coarsely powdered pumice-stone, and exhausted with ether containing no alcohol, whereby the neutral fat is dissolved out. The residue is exhausted with hot alcohol, and the resulting soap solution evaporated and decomposed by a mineral acid, so as to obtain the free fatty acids, originally present as such, free from the other constituents. Or the fat, &c., may be treated with ether, carbon disulphide, or other solvent; by filtering through a weighed filter and washing the insoluble matter thoroughly, the mucilage, &c., is obtained, whilst the filtrate may be evaporated, and the resulting mixture of neutral fat and free fatty acid further examined as required.

Burstyn's Method.—A physical method of approximately determining the amount of free acid contained in oil (more especially olive oil) has been devised by Burstyn† for use in cases where titration by chemical means is inconvenient or impracticable. 100 c.c. of the oil to be tested are placed in a stoppered cylinder capable of holding 200 c.c.; this is then filled up to the mark with alcohol of 88 to 90 per cent., and the whole well shaken, and allowed to stand two or three hours. The alcohol floats up, having dissolved out most of the fatty acids together with a minute amount of oil; the increase in specific gravity is determined by testing the upper layer with a highly delicate aræometer, a similar cylinder of the original alcohol used being simultaneously examined side by side. By the aid of a table

* In presence of alcohol ether is apt to take up into solution small quantities of soap, as well as neutral fat.

† *Dingler's Polyt. Journal*, ccxvii., p. 314; also *Journal Chem. Soc.*, vol. i. (1876), p. 769.

the amount of free fatty acid is deduced from the increment in specific gravity indicated, the table being so constructed as to allow for the solubility in alcohol of the neutral oil, &c. Apart from the error introduced by the possible presence of varying amounts of phytosterol, or other vegetable substances more or less soluble in alcohol, a very slight difference in temperature between the vessels containing the alcoholic oil solution and the pure alcohol used for comparison produces a great effect on the result. The table is usually arranged so as to show the number of "Burstyn degrees" of free acid—*i.e.*, the number of c.c. of normal alkali neutralised by the free acid contained in 100 c.c. of the oil examined. "One degree" consequently represents 0.282 gramme of oleic acid per 100 c.c., or close to 0.3 per cent. by weight.

DETERMINATION OF UNSAPONIFIABLE CONSTITUENTS.

The unsaponifiable matters contained in many oils and fats to the extent of a few tenths per cent., are most conveniently determined by saponifying the oil with alcoholic alkali, evaporating off the spirit, and dissolving out matters soluble in such solvents as ether, chloroform, carbon disulphide, light petroleum spirit, &c., either by means of an extraction arrangement, such as the Soxhlet apparatus described in Chap. IX., or by adding water and agitating with the solvent. Ether frequently dissolves a small amount of soap; on the other hand, small quantities of oil often escape saponification, and are thus extracted; so that it is always preferable to boil a second time with alcoholic alkali the residue left on evaporating off the solvent, and repeat the extraction process with the product. The extraction by means of a Soxhlet arrangement is generally facilitated by placing some sand or powdered pumice-stone in the evaporating vessel employed, and rubbing up therewith the residual soap left after evaporating off the alcohol; the solvent thus obtains more easy access to the matters to be dissolved out, and the operation is effected more quickly and thoroughly.

In the analysis of soaps similar methods are often employed; the soap to be tested is reduced to thin shavings which are then cautiously dried, first at a comparatively low temperature (50°-60° C.), later on at steam heat or a little above, so as to drive off all moisture without fusing the mass. The dried shavings, coarsely powdered, are packed in the Soxhlet tube and exhausted with solvent, preferably light petroleum ether; in this way unsaponified fat contained in the soap, cholesterol and analogous substances derived from the oils and fats employed, waxy matter or hydrocarbons (*e.g.*, paraffin oil) added to

the soap, or contained in the materials (*e.g.*, in distilled oleins), and similar constituents are all dissolved out, giving a solution, the residue left on evaporation of which is further examined; whilst the purified soap is also subjected to analysis.

The modification of Soxhlet's extraction apparatus described by Honig and Spitz (Chap. IX.), is often very convenient for dissolving out the unsaponifiable constituents soluble in ether, light petroleum spirit, &c., after heating with excess of alcoholic alkali, evaporating off the spirit, and dissolving in a minimum of water. The use of petroleum spirit is preferable, as although it often dissolves out a little soap (though usually less than ether), this may be readily removed by agitating with a mixture of equal quantities of alcohol and water (50 per cent. spirit), when the petroleum solution free from soap floats up. Moreover, ethereal liquids often form froths that remain permanent without separating properly for many hours or even days; petroleum spirit is less liable to this inconvenience.

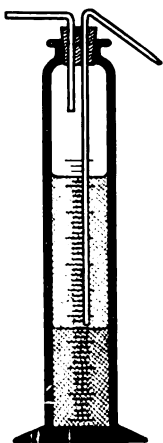

Fig. 27.

In cases where a portion only of the ethereal or other solution is intended to be drawn off, this is readily effected by running the solution and watery fluid into a graduated vessel, into the mouth of which a doubly perforated cork is fitted, with a washbottle-like arrangement of tubes (Fig. 27, Chattaway). The upper and lower levels of the ethereal liquid being read off, the cork and tubes are inserted, and air blown in so as to force out some of the ethereal solution into a weighed dish in which it is subsequently evaporated, the quantity thus drawn off being known by withdrawing the tubes and reading off the difference of level of the top of the ether stratum. When sharp results are required, about 90 to 95 per cent. of the ether should

thus be withdrawn, and the remainder diluted, say tenfold, by adding more ether; the bulk of this is similarly forced out, so that the remaining ether only represents a small percentage of the original ethereal solution. Thus, suppose that the original ethereal fluid measures 58 c.c., of which 52 are removed by the first blowing out, leaving 6. This is diluted to 60, and another 50 c.c. blown out, leaving 10 of the more dilute liquid, representing 1 of the original solution, or $1 \times \frac{100}{58} = 1.72$ per cent. thereof. Then

$100 - 1.72 = 98.28$ per cent. of the original solution has been blown off, so that the weight of the residue obtained therefrom by evaporation must be increased in the proportion $\frac{58}{57} = \frac{100}{98.28}$.

Oils, &c., adulterated with any considerable proportion of

hydrocarbons (paraffin, petroleum, rosin oil, &c.), or similar mixtures intentionally prepared for lubricating purposes, &c., are easily separated by the above treatment; when the fatty acids contained in the saponifiable constituents are required to be further examined, they are readily isolated by dissolving in hot water the soap thus freed from hydrocarbons, and acidulating with a mineral acid.

Blubber oils containing the glycerides of higher ethylic alcohols (cetylic alcohol, &c.) when thus treated yield to the solvent the alcoholiform constituents set free during saponification; when these are mixed with hydrocarbons the proportion of alcohol present may be arrived at by means of the hydrogen test (p. 13), or the acetylation test (Chap. VIII.)

When only minute quantities of unsaponifiable matters are contained in a given oil or fat, &c., these are generally either substances akin to cholesterol and phytosterol dissolved in the oil, or else matters of mucilaginous or albuminous character either dissolved in the oil or suspended in a diluted jelly-like form therein. The former, when dissolved out from the soap resulting after saponification by such solvents as ether or benzoline, may often be obtained in a crystallised condition by dissolving in hot alcohol and cooling, or may be converted into benzoic or acetic ethers, &c., and identified either by the melting point or the "acetyl number." The latter are left undissolved; on decomposing the soaps with a mineral acid they form flocculent masses, from which the pure molten fatty acids are readily separable by filtration through a dry paper filter after separation from the aqueous liquor. Some oleaginous matters, extracted by solvents (such as carbon disulphide) from certain vegetables, seeds, &c., or from certain kinds of animal fatty matter, contain complex bodies of the nature of *lecithin*, a sort of compound ether of choline, glycerophosphoric acid, and fatty acids (oleic and stearic); phosphorised constituents of this kind are largely contained in the oily matter from the yolks of hens' eggs, and to a lesser extent in that from the seeds of certain leguminous plants, *e.g.*, peas (*vide* p. 123).

Matters of a saponaceous character are sometimes contained in commercial oils, owing either to the use of basic substances in refining (especially in boiling drying oils), whereby more or less considerable amounts of metallic soaps are formed and partially dissolved by the oil; or to other causes, such as the intentional addition of metallic soaps (aluminium, magnesium, zinc, &c.) for the purpose of increasing the viscosity of lubricating oils; or simultaneous contact with air and metals, whereby a metallic oxide is formed, which then is either dissolved as metallic soap, in virtue of free fatty acids present, or reacts on the glyceride, forming metallic soap by saponification. Oils that have been in contact with copper or brass are often rendered

green by the formation of copper soap in this way; similarly, drying oils that have been "boiled" with metallic oxides as driers (*e.g.*, lead oxide) generally contain more or less metallic soap in solution thence derived. Such admixtures, whether intentional or not, can generally be estimated by diluting the oil with ether free from alcohol, and filtering, when the metallic soap is left undissolved; by decomposing this with dilute nitric acid the metallic constituents are obtained as nitrates. In most cases prolonged agitation of the oil with highly dilute nitric acid suffices to dissolve out the metallic oxides present as soaps, and in this way errors are avoided due to solubility of metallic soaps in the ethereal solution of oil.

Oils containing lead or copper are more or less blackened by shaking up with a few drops of sulphuretted hydrogen water, or dilute solution of ammonium sulphide. Preferably a mixture of equal volumes of glycerol and water is used to dissolve the sulphur compound employed, as this then acts more readily on the oil.

Oils containing potash and soda soaps in solution generally yield these more or less completely to water when shaken up therewith, so that by allowing to stand and separating the aqueous liquid, the soaps dissolved therein can be obtained by evaporation to dryness.

Water contained in Oils, &c.—Although "oil and water" are conventionally regarded as immiscible substances, still their mutual insolubility is in most cases relative rather than absolute. Water in general dissolves extremely little oil or fat; but the converse does not hold so closely, as a few tenths per cent. of water can generally be retained in permanent solution by fluid oils, &c., without impairing their transparency. In the case of semisolid substances (*e.g.*, butter and lard), much larger quantities of water can be mechanically intermixed with the fat in the form of minute globules interspersed throughout the mass; but in this case there is no true solution, and on gently warming the mass so as to melt the fatty matter, the water gradually separates out to the bottom, so that if the operation be effected in a graduated vessel, the volume of water thus separating may be by and by read off. In some cases, the separation of the water in this way is facilitated by adding to the just-fused mass a sufficient quantity of light petroleum spirit to prevent it solidifying on cooling, and setting by the whole in a corked-up graduated tube for some time, so as to allow the water globules to collect and run together. The amount of admixed water may also be determined by heating a known weight of substance to a temperature a little above 100° C. (by means of an airbath, &c.), and noting the loss of weight.

When the actually dissolved water is to be determined, the same process may be used; preferably, however, the oil, &c., to

be examined is not heated in contact with air, but is placed in a weighed U tube, through which a current of dry carbon dioxide gas is passed, to prevent oxidation by absorption of oxygen from the atmosphere during the heating.

Adulteration of Fats with Suspended Matters.—Solid and semisolid fats (lard, tallow, &c.) are sometimes intentionally adulterated by admixture with white weight-giving substances, such as china-clay, starch, &c. To determine the quantity and nature of the adulterants present in such cases, the fat, &c., is thinned with carbon disulphide or other volatile solvent, and filtered through a dry weighed filter. The filtrate and washings being evaporated to dryness, and the residue dried in a steam bath, the proportion of actual fat present is known; the increment in weight of the filter represents the solid adulterant, and the deficiency in weight the water. The residue on the filter turns blue if starch is present (flour, meal, farina, &c.); cold water dissolves out common salt and such like saline matters (*e.g.*, in salted butters, &c.); kaolin and sand are left behind on incineration, whilst albuminoid and caseous matters, cellulose, mucilage, and other vegetable non-fatty extractives are burnt off during the process. Oils that have been refined by means of sulphuric acid and retain minute quantities of free inorganic acid, when thus treated with a solvent and filtration, leave on the filter paper a minute amount of residue soluble in water with acid reaction; this may be titrated with decinormal alkali in the usual way.

Sulphurised and Phosphorised Constituents.—Certain oils, more especially those derived from cruciferous plants (rape, camelina, mustard, horseradish, cress, &c.), contain small quantities of sulphurised constituents, such as thiocyanic ethers; the presence of these may be qualitatively tested by heating the oil with concentrated potash solution, whereby potassium sulphide is formed; the mass, after dilution with water and separation of the aqueous liquor, gives a brown or black coloration with potassium plumbate. In some cases, heating the oil to "boiling" with a bright strip of silver causes the latter to blacken. To determine the amount of sulphur, the oil is dissolved in sulphur-free petroleum or alcohol, and burnt in the manner employed in determining sulphur in coal gas, the flame being enclosed in a chimney connected with an aspirator, and absorbing tubes filled with moistened glass beads being interposed, so as to condense sulphur dioxide and trioxide along with the water formed by the combustion; a tray with fragments of solid ammonium carbonate is fixed over the flame, to furnish an ammoniacal atmosphere; the condensed liquid is oxidised with bromine water, and precipitated with barium chloride and hydrochloric acid (Allen). Or the oil may be cautiously heated with alcoholic potash, evaporated, and the residue incinerated with addition of potassium nitrate till white, the sulphate formed being determined

as usual. This latter method is also available for the estimation of phosphorus, present in certain oils and fats as a compound of the nature of lecithin, the phosphorus being ultimately weighed as magnesium pyrophosphate (Benedikt).

The following general scheme for the examination of oils and fats, &c., is applicable in most cases so far as the above mentioned impurities or constituents are concerned :—

Dry a convenient quantity so as to determine the amount of water present (p. 122).

Melt a known weight of fat and pass it through a hot weighed filter, finally washing out the adherent fat with ether; the residue left on the filter may contain *saline matters, suspended organic impurities, dust, &c., &c.*, which may be further examined as occasion requires. On incinerating the filter, the amount of inorganic suspended matter is obtained. Part of the filtered oil, &c., may be shaken successively with water to dissolve out alkaline soapy matters, and with dilute nitric or sulphuric acid in case any lead, copper, or other metallic soaps are present, the watery and acid liquors being separated and examined. The oil may advantageously be diluted with ether or carbon disulphide, &c., previously to agitation with water, &c. Another part of the filtered oil is diluted with warm alcohol, and the free acid number determined (p. 116), using phenolphthalein as indicator; the alcohol is evaporated and the residue taken up with light petroleum spirit, &c.; the residual soap formed from the free acid is examined as required (Chap. XXI.) for fatty acids, resin acids, &c. Aluminium and other metallic soaps may also be here present, precontained in the oil.

The light petroleum spirit solution on evaporation gives a residue containing neutral oil, hydrocarbons, and unsaponifiable matters, &c.: this is saponified with alcoholic alkali, and the product diluted with water and shaken with ether or petroleum spirit; the ethereal solution is evaporated and the treatment with alcoholic alkali repeated to ensure complete saponification; finally, the hydrocarbons, &c., are dissolved out by ether or petroleum spirit, and the watery solution of glycerol and fatty acid soaps further examined by acidifying and separating the fatty acids; these usually constitute 95 to 96 per cent. of the original glycerides (Chap. VIII.)

CHAPTER VII.

**CHEMICAL REACTIONS OF OILS, FATS, &c., AND
THEIR USES AS TESTS OF PURITY, &c.****EFFECT OF HEAT ON OILS, &c.**

WHEN fixed oils, &c., are subjected to heat, decomposition is sooner or later brought about; if the oil is a glyceride, acrolein (acrylic aldehyde, $C_2H_3.COH$) is generally evolved, so named on account of the acrid character of its vapour. In some cases the fatty acid originally present as glyceride is also volatilised unchanged in greater or less quantity; but in general, destructive distillation only takes place. If the heating be carried out in presence of water vapour, as when superheated steam is blown through the mass, in many cases hydrolysis takes place, fatty acids and glycerol being produced, which more or less completely pass off along with the water vapour; on this action are based certain processes for the manufacture of free fatty acids for candle making, &c., and for preparing pure glycerol.

When drying oils, more especially linseed, poppy, and walnut oils, are heated for the purpose of preparing "boiled" oil for the manufacture of paint, &c., and particularly when the action is pushed to a great length, as in the manufacture of printing ink, the glyceridic portion of the compounds appears to be almost completely decomposed, the linolic acid or anhydride developed being more or less dehydrated (and probably polymerised) in such fashion as to form a highly viscid or rubber-like mass. Oxidation by direct addition of oxygen so as to form oxylinolic acid and derivatives thereof usually occurs simultaneously, more especially in the "blowing" process of preparing boiled oils.

Flashing Point.—The determination of the temperature at which inflammable vapours are given off (whether by simple volatilisation, or in consequence of decomposition) in sufficient quantity to take fire by the application of a light to the mixture of air and vapour contained in the upper part of the heating vessel, is a somewhat important operation in the case of many oils intended for lubricating and other purposes, where they are liable to be considerably heated; with animal and vegetable oils the "flashing points" are generally high, but much lower numbers are often given by mixtures containing hydrocarbon oils, such as paraffin oil and petroleum distillates, rosin oils, and such

like products. For the determination of the flashing point of petroleum distillates and similar substances, several special forms of instrument have been devised by different experimenters; in some of the earlier forms the vapour emitted from the warmed oil was allowed free access to the air; this mode of operating was known as the "open test," and was subject to serious irregularities according to the way in which the heating was conducted, and so on. In the later instruments the top of the heating vessel is closed in to prevent the escape of inflammable vapours when first generated; in consequence a considerably lower temperature is registered by the application of the "close test," whilst the sources of fluctuation in the

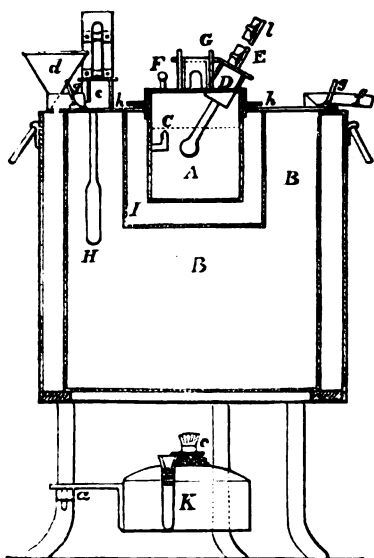

Fig. 28.

water bath, B, heated by a lamp, K, underneath. The oil to be tested is carefully poured in without splashing until just level with the top of the gauge, C, $1\frac{1}{2}$ inches from the bottom of the cup, the water in the jacket being at the temperature $130^{\circ}\text{F.} = 54^{\circ}\cdot4\text{C.}$, as shown by the thermometer, H. The lid of the cup, D, is then put on, the temperature of the oil being known by means of the thermometer, E. A small lamp, G, is arranged at the top of the cover, swinging on an axis, in such a fashion that when a slide covering an aperture in the lid is drawn aside, the lamp flame is made to pass over the aperture. As the contents of the cup slowly heat up, the slide is withdrawn at regular intervals of

Fig. 28 represents Abel's flashing point apparatus, used in Britain as the legalised appliance for testing petroleum, &c., under the Petroleum Act. Similar arrangements are in use in other countries with minor modifications, partly as to the construction of the instrument itself, and partly as to the exact details of manipulation to be observed during use; for as the temperature values deduced are liable to slight fluctuation with variations in the mode of heating, &c., a definite prescribed mode of operating must be strictly adhered to. Abel's apparatus consists of a cylindrical metal cup, A, placed inside another with an air-space between, the outer one being surrounded by a

time, governed by the swinging of a pendulum; by and by, the inflammable vapours are given off in sufficient quantity to yield a flash of blue flame by their kindling when the slide is withdrawn; the temperature then indicated by the thermometer, E, is noted as the flashing point. Obviously this form of apparatus is only suitable for substances the flashing point of which is below the temperature of boiling water; when less volatile substances are to be examined, the water jacket is replaced by a hot bath of some other fluid; or a hot airbath is used instead.

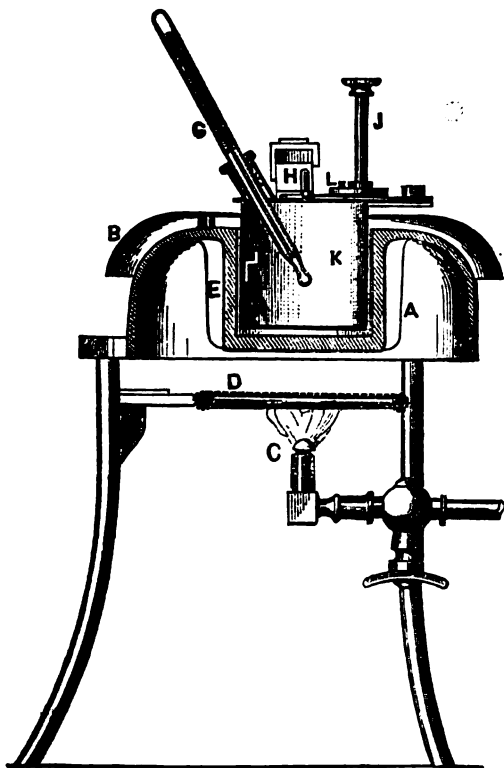

Fig. 29.

Fig. 29 indicates Pensky's modification of Abel's instrument for such purposes, where the source of heat is the lamp flame, C, playing on wire gauze, D, and filling the inverted basin, A, with hot air.*

* An improved form of Pensky's apparatus has been described by Holde (*Journ. Soc. Chem. Ind.*, 1889, p. 734).

Lubricating oils containing hydrocarbons sufficiently volatile to flash at 150° C. or below are distinctly unsafe as regards risk of fire. Animal and vegetable fixed oils (unmixed with hydrocarbons), as a rule, do not flash below 200° to 250° C.; thus A. Künkler gives the following values* as the flashing points observed with various lubricating fluids, mostly consisting of petroleum hydrocarbons, and some natural oils, &c. :—

	Sp. Gr. at 17° C.	Degrees C.
Cylinder oils—Russian,911-.923	183-238
" American,886-.899	280-283
Machine oils—Russian,893-.920	138-197
" American,884-.920	187-206
Spindle oils—Russian,893-.895	163-167
" American,908-.911	187-200
Rape oil—crude,920,	265
" refined,911	305
Olive oil,914	205
Castor oil,963	275
Linseed oil,930	285
Tallow,951	265

Characteristic Oxidation Products.—In certain cases the results furnished by cautious oxidation afford useful indications of the nature of the fatty acids; this is more especially the case when an approximate separation of liquid and solid fatty acids has been previously effected by conversion into lead salts and treatment with ether, so as to dissolve out oleate and linolate of lead, &c., leaving undissolved lead stearate, palmitate, &c. Hazura recommends the following method of operating:—The fatty acids obtained by decomposing the soluble lead salts are neutralised with a slight excess of caustic potash, diluted with 60-70 parts of water, and the liquid treated with about an equal volume of a solution of potassium permanganate added in a thin stream with continuous agitation. After ten minutes sulphurous acid solution is similarly added, sufficient to dissolve all precipitated hydrated manganese dioxide, and to give an acid reaction. The products of oxidation of oleic and linolic acids (dioxystearic and sativic acids) are only difficultly soluble, and consequently precipitate; whilst linusic and isolinusic acids (the oxidation products respectively of linolenic and isolinolenic acids) remain in solution. These latter acids are extracted by neutralising with potash, evaporating to a small bulk (one-twelfth to one-fourteenth of the original volume) and decomposing with sulphuric acid; the precipitate is dried in the air, treated with ether to dissolve out matters readily soluble

* *Journ. Soc. Chem. Ind.*, 1890, p. 197; from *Dingler's Pol. Journ.*, 274, p. 276.

therein, and the residue crystallised from alcohol and from water so as to separate the more soluble isolinusic acid from the less soluble linusic acid. Dioxystearic acid and sativic acid are separated in a similar way from the precipitate thrown down in the earlier stage; the precipitate is washed with a little ether to remove easily soluble fatty acids (unoxidised) and then treated with large bulks of ether (100 parts ether to 1 of substance). Dioxystearic acid is chiefly dissolved out, obtainable by evaporation and recrystallisation of the deposited crystals from alcohol twice in succession; whilst sativic acid is isolated from the insoluble portion by boiling with water, filtering whilst boiling hot, and crystallisation on cooling. The purified acids thus obtained are further identified by means of their melting points (p. 43). According to Benedikt the acetylation test (Chap. VIII.) may also be usefully employed for this purpose.

In somewhat similar fashion trioxystearic and isotrioxystearic acids are obtainable from the fatty acids of castor oil. It is noteworthy in this connection that the acids obtained by the oxidation of isoleic acid and of elaidic acid (the isomeride of oleic acid produced by the action of nitrous acid, p. 28) are dioxystearic acids, isomeric but not identical with that obtained from ordinary oleic acid (Saytzeff, p. 30). Similarly, the oxidation products of erucic acid and its elaido derivative brassic acid, yield two isomeric dioxybenic acids (p. 29).

Spontaneous Oxidation of Oils, Fats, &c.—Oils of the drying class, and to a lesser extent many other oils and fats, possess the property of directly absorbing oxygen from the air at the ordinary temperature, the effect being much more marked when more or less heated; the drying and hardening of paint prepared from linseed oil is an extreme case of such an action, whilst the thickening and "gumming" of various other oils on keeping exhibits the same kind of phenomenon in a lesser degree. The fixation of oxygen during actions of this kind appears to be principally due to a direct combination of oxygen with acid radicles of "unsaturated" character, precisely analogous to the combination therewith of iodine or bromine (p. 31, 45); as the oxidation proceeds, the "iodine absorbing power" of the substance usually diminishes *pari passu*.

In some cases the rapidity with which the absorption of oxygen takes place is greatly enhanced by heating the oil to a temperature insufficient to produce any great degree of decomposition, although high enough to cause incipient breaking-up with evolution of vapours; this process of "boiling" oil, especially when certain metallic compounds or "driers" are added, appears to consist essentially in the formation of substances that act as "carriers" of oxygen;* so that "boiled oils" dry more rapidly

* The rotting of painted canvas sometimes observed appears to be largely due to oxidation of the fibres of the fabric in consequence of this carrier

than the same oils in a raw or unboiled condition, these carriers absorbing oxygen more rapidly from the air, and parting with it again to the unoxidised portions of the oil. Free exposure to air whilst heating, in some cases accompanied by the injection of a current of air through the heated mass, appears to be essential to the production of the initial degree of oxidation effected in the boiling of drying oils; the latter process when applied to various non-drying oils (more especially fish oils), causes a considerable increase in density and viscosity, so that "blown oils" thus prepared are more suitable for lubricating and other purposes than the original untreated substances.

Effect of Light on Oils.—Exposure to light produces a remarkable increase in the rate at which spontaneous oxidation of oils, &c., takes place at the ordinary temperature; the result of this oxidation is uniformly to cause an increment in specific gravity and in the amount of heat evolved on mixture with sulphuric acid (*infra*), together with a decrement in the iodine absorption (Chap. VIII.) Thus, the following figures were obtained (along with many others) by H. Ballantyne* with olive, castor, rape, cotton seed, arachis, and linseed oils; specimens kept in the dark for six months showed little or no alteration whether in tightly corked or open bottles, and whether undisturbed or agitated daily so as to aerate them; whereas similar specimens exposed to sunlight during the same period exhibited perceptible amounts of alteration, even when kept undisturbed in corked bottles; and much larger amounts when kept in uncorked bottles and agitated daily:—

VARIATION IN SPECIFIC GRAVITY.

	Original Value, practically Unchanged in the Dark.	Value after Six Months' Exposure to Sunlight.	
		Undisturbed, Corked.	Agitated Daily, Uncorked.
Olive oil,	·9168	·9185	·9246
Castor oil,	·9679	...	·9683
Rape oil,	·9168	·9171	·9207
Cotton seed oil, . .	·9225	·9236	·9320
Arachis oil, . . .	·9209	·9216	·9267
Linseed oil, . . .	·9325	·9327	·9385

action. The presence of certain kinds of resinous matter (such as are employed in the manufacture of tarpaulins, &c.), seems to diminish the tendency to this destructive action.

* *Journ. Soc. Chem. Ind.*, 1891, p. 29.

VARIATION IN IODINE ABSORPTION.

	Original Value, practically Unchanged in the Dark.	Value after Six Months' Exposure to Sunlight.	
		Undisturbed, Corked.	Agitated Daily, Uncorked.
Olive oil,	83·16	82·64	78·24
Castor oil,	83·63	...	83·27
Rape oil,	105·59	105·27	102·12
Cotton seed oil,	106·84	106·40	100·12
Arachis oil,	98·67	97·60	93·20
Linseed oil,	173·46	172·88	166·17

VARIATION IN HEAT EVOLUTION WITH SULPHURIC ACID.

	Values after Keeping Six Months			
	In the Dark.		In Sunlight.	
	Undisturbed, Corked.	Agitated Daily, Uncorked.	Undisturbed, Corked.	Agitated Daily, Uncorked.
Olive oil,	44°	43°·5	47°	67°
Castor oil,	73°	73°	74°·5	78°·5
Rape oil,	61°·5	60°·5	63°	72°·5
Cotton seed oil,	75°·5	76°·5	76°·5	100°
Arachis oil,	73°·5	73°·5	77°	90°
Linseed oil,	113°·5	112°·5	120°	131°

Only minute amounts of free acid were developed in six months during the course of these observations, indicating but little hydrolysis of glycerides during the oxidation of the insulated samples; the maximum amounts formed were in the case of linseed and cotton seed oils, and corresponded with a development of 0·34 and 0·50 per cent. respectively of free acid (expressed as oleic acid) in sunlight, none at all being formed in the dark. Olive oil kept six months in the dark gave a hard solid elaidin; that exposed to sunlight in corked bottles without agitation a somewhat less hard mass; but that insulated and agitated daily, so as to expose as thoroughly as possible to oxidising influences, did not even thicken when submitted to the elaidin test. Similarly Becchi's silver test for cotton seed oil gave only faint indications with the insulated oxidised oil, although reacting thoroughly with oil kept in the dark. The viscosity of rape oil, as indicated by the efflux

test (p. 95), was notably increased by nine months' exposure to sunlight (in corked bottles without agitation); oil kept in the dark giving times of flow 56 at 15°·5 and 25·5 at 50°, whilst insolated oil gave 66 at 15°·5 and 26·5 at 50°. Castor oil, mainly consisting of the glycerides of acids already oxidised, as might *a priori* be expected, is less changed by oxidation than any of the others.

Similar, but less systematic, observations have been recorded by various other experimenters, the general result of which is to show that the changes brought about in oils and fats by keeping and atmospheric oxidation are greatly accelerated by the influence of light. According to E. Ritsert rancidity is only produced in oils in presence of oxygen (air), the action being greatly accelerated by simultaneous exposure to light. No effect, however, is produced by the action of light alone, when access of oxygen is entirely excluded.

Spontaneous Combustion.—When a film of readily oxidisable oil is spread over a considerable surface, so that a large area is presented for atmospheric oxidation, if the circumstances are such that the heat generated by the action is not readily lost, the mass heats greatly, in some cases to such an extent as to bring about spontaneous inflammation. Gellatly has shown that greasy cotton rags and similar materials kept in a warm place are, in consequence, liable to ignite spontaneously, and are accordingly a source of danger as regards fire. Boiled linseed oil appears to be the most energetic of oils in this respect; a handful of cotton waste soaked in this fluid and squeezed out, and then kept in a box at 70° to 80°, soon rises greatly in temperature to near 200°; in little more than an hour the mass is so hot that smoke issues, and on opening the box the whole takes fire. Unboiled linseed oil takes a much longer time to produce the same result* (from four to six hours), and rape oil longer still (some ten hours). On the other hand, an admixture of mineral oil greatly retards the action. In general, the tendency to spontaneous oxidation is greater the greater the iodine absorption of the oil.

A testing apparatus has been constructed by Allbright & Clark † for determining the comparative liability of oils to spontaneous combustion, consisting of an outer shell formed by a six inch wrought iron tube which can be closed at each end by discs of wood. Inserted into this tube is an inner four inch sheet iron tube with overlapping metal covers at each end, so that an air space is left of one inch around the inner tube, and of three inches at each end; three thermometers are inserted into the inner shell through the outer one. A ball of say 50 grammes

* Renouard, *Journ. Soc. Chem. Ind.*, 1882, p. 184, has repeated and confirmed this difference between boiled and raw linseed oil.

† *Journ. Soc. Chem. Industry*, 1892, p. 547.

of waste, over which an equal weight of oil is distributed, is carefully pushed to one end of the inner tube, and the corresponding thermometer bulb inserted into the middle of the ball. A similar ball of unoiled waste is placed at the other end, with another thermometer bulb inserted as before. The third thermometer is placed between the two. On heating the outer tube by means of a Bunsen burner, so that the central thermometer indicates about 125° , the temperature of the unoiled waste ball will be about 100° . That of the other rises in proportion as the oil oxidises more rapidly. E. H. Richards reports that this arrangement gives most valuable results as regards gauging the degree of safety of lubricating oils, &c.; for instance, the percentage of fatty oil which may be safely mixed with mineral oils may be thus determined. Thus neat's foot oil and best lard oil may be added to the extent of 50-60 per cent., whilst not more than 25 per cent. of cotton seed oil is permissible.

Film-test.—If a film of oil be freely exposed to the air, so that heating to any considerable extent is impracticable, the effect of the oxidation is gradually to inspissate the oil, and finally to convert it into a varnish-like product; a test of the quality of a given sample of drying oil is based upon this, a glass plate being coated on one side with a film of oil, after the fashion of a photographer's collodion plate, and then kept in a steam bath for some hours, preferably side by side with another plate similarly coated with oil of standard quality; the relative length of time requisite before the film ceases to be "tacky," being converted into a dry varnish, serves as a measure of its drying quality. Thus, whilst a good sample of linseed oil is completely solidified in some twelve hours, non-drying oils like arachis and olive oils are scarcely thickened at all; whilst cotton seed oil and similar substances possessing only a certain degree of drying power are intermediate. In this respect the order in which oils are arranged by means of this test is sensibly the same as that in which they are arranged by means of the iodine absorption reaction (Chap. VIII.)

Livache's Test.—Livache finds that the rate of absorption of oxygen is much quickened if finely divided metallic lead is mixed with the oil to be examined; comparative tests are readily made by placing on a watchglass about a gramme of lead* in a thin layer, and then dropping on to it a few decigrammes (not more than 6 or 7) of oil in small drops, scattered over different portions of the lead, so as not to run into one another. The whole is then weighed and allowed to stand at the ordinary temperature. Drying oils begin to increase measurably in weight in less than twenty-four hours, and cease to gain weight

* Precipitated from lead acetate solution, and rapidly washed with water, alcohol, and ether in succession, and finally dried in vacuo. According to Hübl, precipitated copper is preferable to lead.

after three to six days, whilst oils possessing little or no drying qualities do not increase at all for several days. Similar remarks apply to the fatty acids isolated from the oils. Thus the following figures were obtained :—

	Percentage Increment in Weight		
	Of Oil after		Of Fatty Acids after 8 Days.
	2 Days.	7 Days.	
Linseed oil,	14.3	...	11.0
Nut oil,	7.9	...	6.0
Poppy oil,	6.8	...	3.7
Cotton seed oil,	5.9	...	0.8
Beech mast oil,	4.3	...	2.6
Colza oil,	Nil.	2.9	2.6
Arachis oil,	Nil.	1.8	1.3
Rape oil,	Nil.	2.9	0.9
Olive oil,	Nil.	1.7	0.7
Sesamé oil,	Nil.	2.4	2.0

Bach,* following Fresenius, tests the oxygen-absorbing power of oils by heating in a closed tube containing oxygen, and noting the bulk of gas absorbed. The presence of excess of oxygen after the experiment must be proved by means of a glowing splinter of wood. This test is more particularly useful in the valuation of certain kinds of lubricating oils.

CHEMICAL CHANGES OCCURRING DURING DRYING OF OILS.

The nature of the chemical changes taking place during the complete atmospheric oxidation and consequent drying up of a drying oil has been the subject of various investigations; but it can hardly be said that the matter is yet settled beyond dispute. The earlier researches on linseed and other drying oils by Mulder and others led to the conclusion that the chief constituent of drying oils, giving them their peculiar properties, was *linolin*, the glyceride of *linolic acid*, regarded as $C_{18}H_{28}O_2$, and then termed *linoleic acid*. During drying this glyceride was supposed to become hydrolysed or otherwise broken up, losing its glyceridic character, and forming *oxylinoleic acid*, $C_{18}H_{26}O_5 \cdot 2H_2O$, by oxidation; a neutral polymerised amorphous anhydro derivative, *linoxyn*, $C_{22}H_{34}O_{11}$, being subsequently developed as the leading ingredient of the "skin" formed as the oil dries. Later researches have indicated that what was formerly

* *Journ. Soc. Chem. Ind.*, 1889, p. 950; from *Chem. Zeit.*, 13, p. 905.

termed "linoleic acid," $C_{16}H_{32}O_2$, is really a mixture of three acids of notably higher molecular weights—viz., *true linolic acid*, $C_{18}H_{32}O_2$, related to oleic acid as oleic acid is to stearic; and two isomeric acids still less saturated, related to linolic acid in the same way, *linolenic* and *isolinolenic acids*, both represented by $C_{18}H_{30}O_2$. These substances by gentle oxidation yield crystallisable acid products, *sativic acid* (tetroxystearic acid), melting at 173° , being formed from linolic acid, and *linusic* and *isolinusic acids* (hexoxystearic acids), melting at 203° to 205° and 173° to 175° respectively (*vide* p. 43), being produced from the other two acids; but these crystallisable ultimate oxidation products are apparently not formed in the "boiling" process at all; and even if contained in the dried skins are certainly not the constituents giving the peculiar physical properties to these substances. Moreover, the proportions of oxygen and water requisite to be taken up by linolic and linolenic glycerides in order to convert them into free oxy-stearic acids, are greatly in excess of the increment in weight observed to take place during the drying of oils of this class (p. 134); whilst the skins are found to be susceptible of some degree of saponification, furnishing glycerol. Hence it would seem probable that the essential constituents of dried skins are a mixture of polymerised glycerides (possibly more or less hydrolysed) of acids derived from linolic, linolenic, and isolinolenic acids by oxidation processes not carried so far as to produce the various oxystearic acids obtainable by means of alkaline permanganate.* That some of these substances are of a feebly acid character, or at any rate are capable of forming salts by the action of metallic oxides, is suggested by the well-known fact that the effect of basic matters like white lead (basic lead carbonate) and zinc white (chiefly zinc oxide) on the paint produced by their admixture with drying oils is different in many respects from that of neutral pigments like lead sulphate and sulphate of barium; in practice these latter are found to be far less suitable for the production of firm adherent coats that will stand ordinary wear and tear, which is usually considered to be due to the absence of the metallic salts contained in white lead and zinc white paints, formed by the neutralisation of acids developed by oxidation, or possibly by the saponification of glycerides.

The drying qualities of an oil appear to be the more marked the greater the proportion of linolenic and isolinolenic acids is

* Fabrion (*Zeitsch. f. angew. Chem.*, 1891, p. 540; 1892, p. 171) finds that the acids formed on saponification of boiled linseed oil where partial oxidation has taken place are not wholly soluble in light petroleum spirit, whereas the fatty acids of unoxidised oil are readily soluble therein; from 0.6 to 31.6 of such insoluble acids were found in different samples of oil. The proportion present appears to be the greater the more marked the decrement in "iodine absorbing power" produced by the oxidation process. These "oxyacids" readily dissolve both in alcohol and in ether.

present. Hazura and Grüssner deduced the following percentages from the relative proportions in which the oxystearic acids were produced on oxidising the liquid fatty acids of linseed, hemp seed, nut, poppy seed, and cotton seed oils, the solid acids being previously separated by conversion into lead salts and treatment with ether (p. 112).

	Linolenic Acid.	Isolinolenic Acid.	Linolic Acid.	Oleic Acid.
Linseed oil, . . .	15	65	15	5
Hemp seed oil, . . .	15		70	15
Nut oil,	13		80	7
Poppy seed oil, . . .	5		65	30
Cotton seed oil,		60	40

Bauer and Hazura regard the drying of oils as being mainly due to the linolenic and isolinolenic acids, which, by taking up oxygen, become converted into the "oxylinoleic acid" of Mulder, which they regard as $C_{18}H_{30}O_7$. For the most part, however, the glyceridic character of the product is not destroyed during the oxidation, so that, instead of free acid, a neutral body results, substantially the "linoxyn" of Mulder, but termed by them *hydroxylinolein*. Small quantities of free fatty acids are, however, developed by the decomposition of the glycerides of the solid fatty acids present (myricin, palmitin, &c.); the glycerol of these glycerides being converted into carbon dioxide and other volatile products.

According to experiments by Cloez,* the effect produced by prolonged exposure to air of a drying oil is not quite so simple as would appear from the above. The following figures were obtained with linseed and poppy seed oils, the final increment in weight being a little more than 7 per cent. in each case after eighteen months:—

LINSEED OIL.

	Before Exposure.	After Oxidation.	
		Percentage Composition.	Calculated per 100 Parts of Linseed Oil originally used.
Carbon,	77.57	67.55	72.30
Hydrogen,	11.33	9.88	10.57
Oxygen,	11.10	25.57	24.16
	100.00	100.00	107.03

POPPY SEED OIL.

	Before Exposure.	After Oxidation.	
		Percentage Composition.	Calculated per 100 Parts of Linseed Oil originally used.
Carbon, . . .	77.50	66.68	71.38
Hydrogen, . . .	11.40	9.94	10.64
Oxygen, . . .	11.10	23.38	25.03
	100.00	100.00	107.05

The original oils thus had a composition closely akin to that of a triglyceride of an acid of formula $C_{18}H_{33}O_2$ (p. 33), requiring carbon 77.90, hydrogen 11.16, oxygen 10.94; during oxidation, from $\frac{1}{2}$ to $\frac{1}{4}$ of the carbon disappeared and not far from the same proportion of hydrogen. Even if the whole of the glyceridic part of the oil had been oxidised to volatile products, only $\frac{1}{6}$ of the carbon would have disappeared; so that, obviously, carbon dioxide, or acetic acid, &c., must have been formed at the expense of the fatty acids present, indicating a more deep-seated oxidation change than the simple absorption of oxygen, converting the glycerides of linolenic and isolinolenic acids into hydroxylinolein.

With castor oil Cloez found the gain in weight after eighteen months was much less marked (2.68 per cent.); whilst only a practically inappreciable amount (0.4 per cent.) of the original carbon had disappeared. Intermediate results were obtained with a semi-drying oil, sesamé oil, the gain in weight in eighteen months being 4.83 per cent., and the loss of carbon about $\frac{1}{7}$ of the original amount.

POUTET'S ELAIDIN REACTION—NITROUS ACID TEST.

Oils containing unsaturated acid glycerides, more especially olein and its homologues, or ricinolein, often undergo a marked change, when treated with nitrous acid, becoming more or less solidified without alteration of composition. Gaseous nitrous anhydride (fumes from nitric acid heated with starch or arsenious anhydride) will produce the reaction, or agitation with substance containing nitrous acid dissolved—*e.g.*, red nitric acid, solution of a nitrite recently acidified, copper or mercury recently dissolved in nitric acid, or even nitric acid warmed until it begins to act on the oil. Of these the liquid originally

described by Poutet, obtained by dissolving 12 parts by weight of mercury in 15 of cold nitric acid (sp. gr. 1.35), is the most convenient; * 2 c.c. of the fresh deep green liquid, and 50 of oil are shaken together in a bottle at intervals for about two hours, at the end of which time the action is nearly complete, although the product usually becomes stiffer or harder on standing twenty-four hours. Olive oil of good quality thus treated gives a bright yellow extremely hard "elaidin;" arachis and lard oils yield products little inferior in stiffness; mustard, rape, sesamé, sunflower, cotton seed, and other oils give softer products, varying in consistency from a stiff buttery mass to a mixture of pasty product with still fluid substance; whilst linseed and other drying oils are comparatively little affected.

A. H. Allen classifies the more important fixed oils as follows, in accordance with the physical character of the product:—

Solid Hard Mass.	Buttery Mass.	Pasty or Buttery Mass separating from a Fluid Portion.	Liquid Products.
Olive oil. Almond oil. Arachis oil. Lard oil. Sperm oil. Neat's foot oil (sometimes).	Bottlenose oil. Mustard oil. Neat's foot oil Arachis oil Sperm oil Rape oil	Rape oil. Mustard oil. Sesamé oil. Cotton seed oil. Sunflower seed oil. Niger seed oil. Cod liver oil. Whale oil. Porpoise oil.	Linseed oil. Hempseed oil. Walnut oil.

In certain cases (more especially with olive oil) the nature and consistency of the elaidin formed on treatment with nitrous acid affords a useful means of detecting the presence of adulterations with oils of different character. In all such cases, the most satisfactory results are obtained when the oil examined is tested side by side in the same way with samples of oil of standard purity, and of the same mixed with known proportions of other oils.†

The free fatty acids obtained by saponifying oils and decomposing the resulting soaps with a mineral acid, are affected by nitrous acid in similar fashion. Attempts have been made to

* Archbutt (*Journ. Soc. Chem. Ind.*, 1886, p. 303) dissolves 18 grammes of mercury in 15.6 c.c. of nitric acid, sp. gr. 1.42 (22.2 grammes of acid), and uses 1 part of the resulting green fluid to 12 of oil (by weight).

† There is often great difficulty experienced in obtaining absolutely pure samples of oil for use as standards. In many cases it is only possible to obtain such standard substances by actual expression of hand-picked seeds, &c., in the laboratory, and subsequently refining the product; but this is not readily practicable, unless a plentiful supply of pure seed is to hand, as well as a good form of small experimental or laboratory press.

utilise for candle-making and other purposes the polymerised solid acids of higher melting point thus formed; but, hitherto, various practical difficulties have stood in the way of utilising the products effectively.

Legler's Consistency Tester.—Legler has constructed a simple form of apparatus by means of which comparative tests can be made of the degree of consistence of the elaidin mass produced when any given oil sample is treated with nitrous acid. It consists of piece of glass tubing narrowed at one end (Fig. 30); through the tube passes a glass rod supported by means of a spiral spring, and furnished with a horizontal disc on the top, so that by placing weights on the disc the end of the rod is depressed to an extent proportionate to the weight added. The outer tube is held vertically by a suitable clamp holder, so adjusted that the bluntly pointed end of the rod just rests on the surface of the elaidin to be tested. The measurement is made by placing a given weight on the disc and noting how far the rod sinks into the elaidin in a given time (*e.g.*, a minute), by reading off the level on a scale the zero point of which is level with the top of the outer tube when the disc is unweighted. The elaidin samples are best prepared by mixing together 10 c.c. of oil, 10 c.c. of nitric acid of 25 per cent., and 1 grm. of copper wire or turnings, and allowing to stand twenty-four hours; the mass is fused by dipping the containing vessel in warm water so as to bring about complete separation of elaidin and watery fluid, and the former removed and allowed to solidify. To obtain comparable results, a uniform method of manipulating should be adopted, the samples tested being examined side by side with others similarly prepared from genuine oils or known mixtures.

Exposure of olive oil to sunlight greatly diminishes the solidity of the elaidin formed from it; the nature of the change brought about is uncertain; probably oxidation takes place with formation of oxyolein (or possibly linolin), as the insulated oil develops more heat by the action of sulphuric acid than the original oil kept in darkness (*vide* p. 131).

Nitric Acid Test.—When fixed oils are brought into contact with nitric acid a complex effect is often produced; oxidation of a part of the oil by the acid is brought about with the evolution of lower oxides of nitrogen, which convert the olein constituent of the oil into elaidin. In some cases, characteristic colours are produced with oils of pure nature, so that a comparison of the

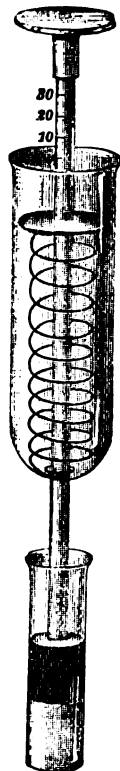

Fig. 30.

substance tested with a pure standard substance, or with a known mixture, enables deductions to be drawn as to the nature of the admixture or adulteration present. This kind of test is more especially useful in the case of olive oil; thus, when pure olive oil is treated with one-ninth its volume of nitric acid of sp. gr. 1.42, the mixture being gently warmed in a capacious dish until the acid begins to act pretty vigorously, and then stirred briskly (the source of heat being removed) until no further action is visible, a pale yellow solid mass is formed after standing an hour or two; whereas, if cotton seed oil be present, a much darker tinted product is formed, which does not set so readily; and similarly when various other oils are present.

A. H. Allen gives the following table,* indicating the different tests developed when several of the commonest oils are tested in the following ways:—

a. *Hauchcorne's Test*, as extended by *Stoddart*.—Agitate to

Oil.	a.	b.	c.
Olive oil, .	Colourless or transient yellow.	Colourless, yellowish, or greenish.	Broad bright bluish green zone.
Almond oil, .	Nearly colourless, changing to solid white mass.	Colourless or slightly greenish.	Narrow bright green zone; oil flocculent or opaque.
Arachis oil,	Reddish.	...
Peach kernel oil,	...	Immediate red liniment.	...
Rape oil, .	Red or orange.	Reddish or orange.	...
Sesame oil,	Yellowish or orange.	...
Cotton seed oil,	Red or orange.	Reddish or orange.	Brown red, greenish below.
Niger seed oil,	Red or orange.	Brown or brownish red.	...
Linseed oil, .	Red or orange.	Red or orange.	Green zone, oil red.
Poppy seed oil,	...	Reddish.	Dark green zone, oil pink.
Hemp seed oil,	...	Brownish red.	...
Castor oil, .	Transient yellow.	Yellowish or orange.	...
Lard oil, .	Colourless or transient yellow.
Whale oil, .	Dark red.
Seal oil, .	Dark red.
Cod liver oil,	Brown red.
Rosin oil, .	Reddish brown.
Mineral oil, .	Dark red.

* *Commercial Organic Analysis*, vol. ii., p. 61.

gether from 3 to 5 measures of the oil with 1 of nitric acid of specific gravity 1.32. Heat the tube for five minutes in boiling water; then take it out and allow it to stand. Observe the colour of the oil from time to time for one and a-half hours.

b. Massie's Test.—Agitate 3 measures of the oil for two minutes with 1 measure of colourless nitric acid of specific gravity 1.40. Observe the colour of the oil after separation.

c. Glüssner's Test.—Pour the oil cautiously into an equal measure of red fuming nitric acid, and observe the colour of the oil and of the zone which forms between the oil and the acid liquid.

ZINC CHLORIDE REACTION AND COLOUR TEST.

Some oils, more especially castor oil, when heated in contact with a highly concentrated solution of zinc chloride, become converted into a gristly mass, which, on treatment with water to dissolve out the zinc chloride, more or less breaks up into cartilaginous or fibrous portions, which swell up largely to white masses closely resembling rasped cartilage, the oil being completely solidified by the process. Apparently, the chemical action consists chiefly of polymerisation, somewhat after the fashion of the elaidin reaction, possibly accompanied by dehydration; by long continued boiling of the product with alkalis, partial saponification is effected, glycerol being set free.

To produce the most gristly product, the following process may be followed:—Zinc chloride solution is boiled down until the boiling temperature rises to about 175° C. or upwards, the composition of the fluid then being close to that indicated by the formula, $\text{ZnCl}_2 \cdot \text{H}_2\text{O}$, or slightly less hydrated. Three parts of this fluid by weight, and one of castor oil are then well intermixed together at a temperature of 125° or thereabouts; the oil speedily becomes more viscid, and then coagulates to a leathery mass resembling bullock's liver, but tougher, mostly separating from the zinc chloride in so doing. This mass is then chopped up, soaked in water till disintegrated to a mass somewhat resembling coarsely scraped horseradish, drained from zinc chloride solution and washed, when it is in suitable condition for use in the manufacture of india-rubber substitutes, insulating coatings for electric leads, &c.

By using weaker zinc chloride, or smaller proportions, or lower temperatures, the action can be controlled and stopped before going quite so far, so as to produce substances of less cartilaginous and more plastic character; or other oils, less

* Patent specification, C580, 1886, Muirhead and Alder Wright.

readily acted upon, may be mixed with the castor oil ; or resin, Kauri gum, and similar substances may be similarly admixed.

Colour Test.—When zinc chloride solution of somewhat lesser strength (of thick syrupy consistence when cold) is mixed with certain oils, colours are developed. Muter gives the following table, founded on the results of Chateau :*

To 10 drops of the oil in a porcelain capsule, add 5 drops of syrupy zinc chloride, and stir.

White or scarcely affected.	Yellow, Red, or Brown.	Green or Blue Shades.
Poppy.	Linseed (English),	Linseed (foreign), bluish green.
Nut.	Rape,	
Almond (hot pressed).	Groundnut,	Olive, } green. Colza, }
Gingelly.	Castor, rose yellow.	
Cokernut.	Beech, flesh rose.	Gold of pleasure (camelina), pale green.
Neat's foot.	Cotton, brown.	Almond, milky with green tinge.
Lard.	Whale, yellow brown.	Cod liver (hot), green.
Horse bone.	Fish, orange yellow.	
Sperm.	Seal, red brown.	
Whale (sometimes pale violet tinge).		
Cod liver (cold).		

Action of Zinc Chloride on Oleic Acid.—Zinc chloride, when heated with oleic acid, converts it into a solid isomeride closely resembling oleic acid, but not identical therewith ; thus, when oleic acid, mixed with 10 per cent. of its weight of zinc chloride, is heated to 180° to 185° (but not exceeding 195°) for some time, the transformation is so far complete that a sample taken out and treated with hot dilute hydrochloric acid yields a layer of fatty acids, solidifying on cooling. By diluting with water and subjecting to distillation with superheated steam (or under diminished pressure), a buttery mass is obtained which, on pressing (first cold and then hot), finally yields a hard crystallisable material of melting point 41° to 42°, suitable for making certain kinds of candles not requiring fatty matter of high fusing point (Schmidt's process). Benedikt obtained the following results on analysis of the products thus formed :—†

A. Crude product obtained by boiling the heated mass with diluted hydrochloric acid.

B. Product of distillation under diminished pressure.

C. Solid mass, after pressing until the melting point rises to 41° to 42°.

* Spon's *Encyclopædia of Arts and Manufactures*, ii., p. 1473.

† *Journ. Soc. Chem. Ind.*, 1890, p. 658; from *Monatsh.*, 1890, ii., p. 71.

	A.	B.	C.
Liquid anhydride,	8
Stearolactone,	28	31.0	75.8
Oxystearic acid,	17
Oleic and isoleic acids,	40	43.3	15.7*
Saturated fatty acids,	7	12.1	8.5
Unsapoifiable matters,	13.6	...
	100	100.0	100.0

The "unsapoifiable matters" contained in B were mainly liquid hydrocarbons of the olefine series (carbon = 84.1, hydrogen = 13.7, oxygen = 2.2).

It would appear that the general character of the main action is that zinc chloride directly combines with the oleic acid, and that the resulting compound (or, possibly, pair of isomeric compounds) is partly decomposed again into oleic and isoleic acids, and partly hydrolysed with formation of oxystearic acids, more especially the γ acid, which then loses the elements of water, forming stearolactone (*vide p. 39*); the hydrolytic action probably being as follows:—

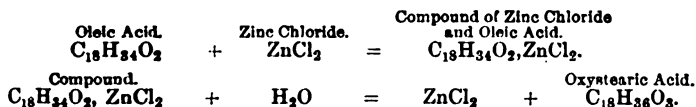

In all probability, similar reactions occur when glycerides containing olein are saponified by means of sulphuric acid, the yield of *liquid* oleic acid in the products finally obtained by distillation with superheated steam being very small.

ACTION OF SULPHURIC ACID ON OILS AND FATS. TURKEY RED OILS.

When sulphuric acid is added to a fixed oil or fat, various kinds of effects are produced in different cases; in many instances distinctive colours are developed, due not so much to the action of the acid on the glycerides themselves as to that upon other bodies accompanying them in small proportion; this is especially marked in the case of certain fish liver oils where biliary constituents are present (*vide infra*). In other cases action occurs between the acid and the glyceride, producing more or less

* Isoleic acid only.

marked heat development, sometimes leading to charring and destruction, sometimes to less deep-seated changes of a definite character. Thus, when oils mainly consisting of olein are cautiously mixed with sulphuric acid hydrolysis ensues, the resulting glycerol being more or less converted into *glycerosulphuric acid*, much as ordinary alcohol is into ethylsulphuric acid.

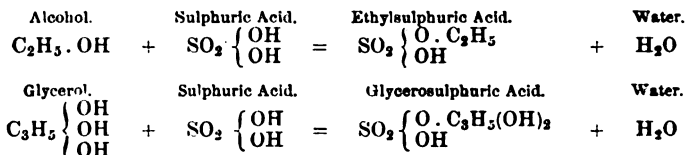

Simultaneously the oleic acid is acted upon, direct combination taking place between the two acids* with the formation of *oxystearosulphuric acid*.

* According to Müller-Jacobs, the product thus formed contains the elements of a molecule of water less, $\text{C}_{18}\text{H}_{34}\text{O}_5\text{S}$ instead of $\text{C}_{18}\text{H}_{36}\text{O}_6\text{S}$; and is represented by him as a sort of sulphonic acid, $\text{C}_{17}\text{H}_{32} \cdot \begin{Bmatrix} \text{SO}_2 \cdot \text{OH} \\ \text{CO} \cdot \text{OH} \end{Bmatrix}$, breaking

up on hydrolysis with the formation of oxystearic acid, $\text{C}_{17}\text{H}_{34} \cdot \begin{Bmatrix} \text{OH} \\ \text{CO} \cdot \text{OH} \end{Bmatrix}$, oxyoleic acid, $\text{C}_{17}\text{H}_{32} \cdot \begin{Bmatrix} \text{OH} \\ \text{CO} \cdot \text{OH} \end{Bmatrix}$ being also formed, probably by a secondary action. Geitel considers that a mixed glyceride is formed, part of the three oleic radicles being modified by direct addition of sulphuric acid thereto so as to form a glyceride where the radicle of oxystearosulphuric acid partly replaces the oleic radicle, saponification of the glyceride not taking place, at any rate, at first.

Liechti and Suida also consider a mixed glyceride to be the first product, containing simultaneously the radicles of sulphuric and oxystearic acids, thus—

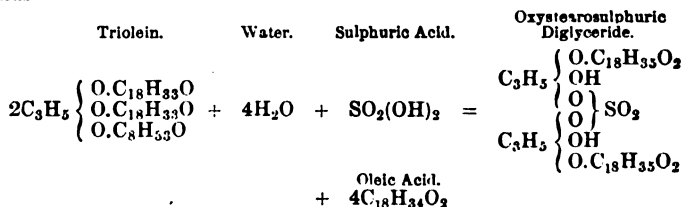

Simultaneously, they regard an analogous mixed diglyceride as being formed, containing the radicle of oxyoleic acid ($\text{C}_{18}\text{H}_{33}\text{O}_2$) instead of that of oxystearic acid ($\text{C}_{18}\text{H}_{35}\text{O}_2$), this substance being produced in virtue of an oxidising action exerted by the sulphuric acid, whereby SO_2 is evolved.

Inasmuch as practically no glycerol is obtainable from Turkey red oil by saponification (beyond what is due to undecomposed original oil present therein), whilst free oleic acid gives products similar to those prepared from olive oil (the more free acid contained in the oil the better it is suited for the purpose), it is obvious that these mixed glycerides, even if formed under special conditions, are at any rate not the main constituents of the commercial products.

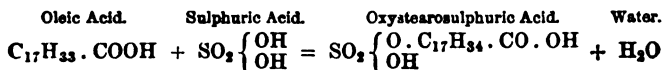

This product, being a saturated compound, does not combine with iodine like the original oleic acid (Benedikt and Ulzer); under the influence of hydrolysing agents it breaks up into oxystearic and sulphuric acids, thus *—

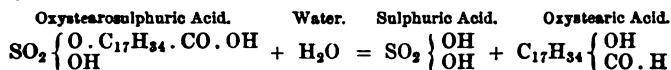

Products containing more or less oxystearosulphuric acid and the oxystearic acid thence formed by hydrolysis, together with unchanged olein, and some free oleic acid (also whatever solid fatty glycerides were originally present in the oil employed and the products of the action of sulphuric acid thereon) are manufactured from olive, cotton seed, and similar oils chiefly consisting of olein, for use in dyeing and calico printing, especially in the production of "Turkey red," whence the name "Turkey red oils" applied to these products; the free acidity is usually partially or wholly neutralised by cautious addition of ammonia or other alkali to the oil after washing with brine or water.

Another variety of Turkey red oil, considerably superior for some special applications, is produced when castor oil is employed instead of olein-containing oils. According to the generally received view, the chief action of the sulphuric acid is precisely analogous to that on ordinary alcohol; the glyceride is hydrolysed into glycerol and ricinoleic acid, the former being more or less converted into glycerosulphuric acid, as above; the ricinoleic acid reacts on the sulphuric acid in a parallel way, forming *ricinoleosulphuric acid*, thus—

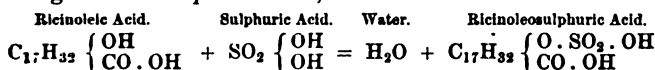

the resulting product differing from that formed from oleic acid in that it contains H₂ less, and is, therefore, an "unsaturated" compound, capable of taking up iodine or bromine in the same manner as the original ricinoleic acid itself (Benedikt and Ulzer). Accordingly, castor Turkey red oil is capable of taking up oxygen, and generally of behaving in ways not observed in the case of olive Turkey red oil; which circumstance renders it more suitable for certain particular applications in reference to dyestuffs, &c.

* The effect of sulphuric acid in decomposing fatty glycerides, together with the hydrolysing action of water on the product, is utilised in the preparation of candle material; a larger yield of solid matter is thus obtained than by the ordinary saponification processes, on account of the conversion of liquid oleic acid into solid substances. According to Geitel, *γ-oxystearic acid* (p. 39) is usually produced (*inter alia*) by the hydrolysis of the compound of oleic acid with sulphuric acid, which immediately splits up into water and stearylactone.

A somewhat different view of the action of sulphuric acid on castor oil has been lately put forth by Scheurer Kestner* as the result of his investigations. After the glyceride has been hydrolysed, he finds that part of the resulting ricinoleic acid becomes "polymerised" (or more accurately, dehydrated and "condensed"), so as to form a more complex molecule of *diricinoleic acid*, which is then acted upon by sulphuric acid so as to form *diricinoleosulphuric acid*; the reactions may be written thus—

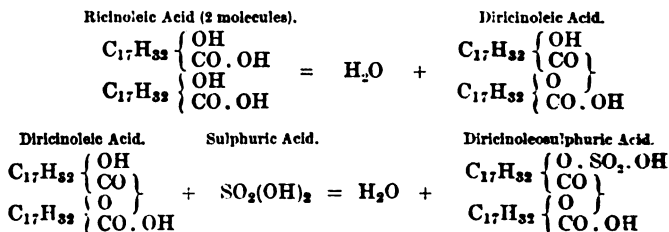

Obviously the diricinoleosulphuric acid thus formed is "unsaturated," and is, therefore, capable of taking up two halogen atoms for each C_{18} present. More or less of the diricinoleic acid escapes conversion into diricinoleosulphuric acid; so that in addition to unaltered castor oil, &c., the resulting Turkey red oil consists of a mixture of diricinoleic acid, and diricinoleosulphuric acid, together with some amount of ricinoleic acid that has escaped condensation to diricinoleic acid, and of ricinoleosulphuric acid formed by the direct action of sulphuric acid upon it. The non-sulphurised fatty acids tend to the development of blue shades with alizarin, whilst the ricinoleosulphuric acids tend to produce yellow shades.

Diricinoleosulphuric acid is hydrolysed by caustic alkali, the soda or potash salts of diricinoleic and sulphuric acids being formed if the action take place at temperatures below 80°C .; but by prolonged boiling with alkali, or treatment therewith under pressure, water is taken up and ordinary ricinoleic acid regenerated by reversal of the two reactions above indicated. In just the same way ricinoleosulphuric acid becomes hydrolysed into sulphuric and ricinoleic acids, the action taking place extremely readily in presence of hydrochloric acid. In presence of sulphuric acid, Turkey red oil is apt to be yet further decomposed on heating, œnanthic acid, *inter alia*, being formed; hence, in the preparation of the oil care must be taken that overheating does not take place; and similarly in washing out the excess of sulphuric acid, &c., with brine (to avoid solution of the soluble compound sulphuric acids formed), otherwise hydrochloric acid is apt to be formed and considerable loss of soluble acids occasioned by

* *Comptes Rendus*, 112, pp. 158 and 395; also, *Journ. Soc. Chem. Ind.*, 1891, p. 471.

hydrolysis; sodium sulphate is accordingly preferable to sodium chloride as diminishing this tendency to loss.

According to Juillard* acids still more highly "polymerised" than diricinoleic acid are formed when sulphuric acid acts on castor oil, three, four, and five molecules of ricinoleic acid becoming condensed and dehydrated, with the formation of *triricinoleic*, *tetraricinoleic*, and *pentaricinoleic* acids respectively. He regards the first action as giving rise, by partial hydrolysis and etherifying action jointly, to the product,

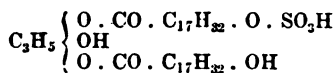

which then loses a molecule of water forming an anhydride, termed by him *dicinolein sulphuric anhydride*.

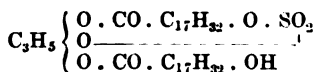

This reacts slowly with ricinoleic acid and sulphuric acids forming the various polyricinoleic acids above mentioned, and the polyricinoleo sulphuric acids thence derived; so that commercial castor Turkey red oils are highly complex mixtures.

Maumené's Sulphuric Acid Thermal Test.—A considerable development of heat usually attends the chemical action brought about on mixing together a fixed oil and strong sulphuric acid; by making comparative observations in precisely the same way with standard pure oils, or known mixtures, and the substance to be tested, useful information can often be obtained as to the character, and to some extent the amount, of foreign admixture present. It is, however, impossible to lay down any precise figures universally applicable in such cases, because the rate of action, and consequently the rise in temperature, greatly depends on the way in which the intermixture is effected, and especially on the strength of the acid used. Commercial oil of vitriol varies considerably in its strength, sometimes containing

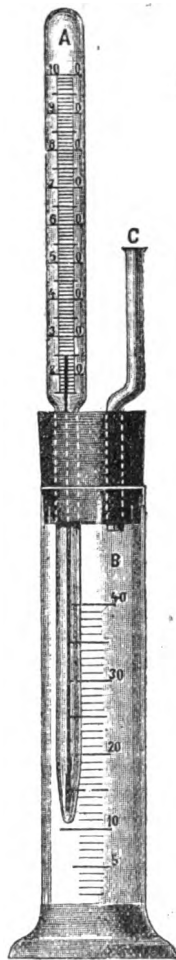

Fig. 31.

* *Journ. Soc. Chem. Ind.*, 1892, p. 355; from *Bulletin Soc. Chim.*, Paris, 1891, 6, p. 638.

96 to 97 per cent. of true sulphuric acid, H_2SO_4 , sometimes only 90 to 91 per cent., or even less. If the liquid be boiled in a retort under ordinary atmospheric pressure until about a quarter has distilled over, the residue when cool enough may be bottled and kept for use, being acid of about 98 per cent. strength.*

Fig 31 represents a form of apparatus for applying the test; a graduated cylinder, B, is provided with an india-rubber stopper, through which passes the stem of a thermometer, A, so graduated that the divisions are all above the stopper; a short piece of quill tubing, C, also passes through the stopper, serving as a vent. 25 c.c. of oil are run into the cylinder, and then 5 c.c. of sulphuric acid, the latter by means of a pipette applied to the side of the cylinder, so that the acid falls to the bottom without mixing with the oil. The stopper and thermometer being inserted and the temperature taken, the end of C is closed by the finger, and the whole shaken up for a few seconds; C is immediately unclosed, and the thermometer watched, so as to note the highest point to which it rises, and hence the range through which the chemical action has heated the mass.

In order to diminish errors due to radiation and convection, a small beaker may be used, jacketted outside with a somewhat larger one, the interspace being filled with cotton wool or fibrous asbestos. 50 grammes of oil and 10 c.c. of sulphuric acid are convenient quantities, the two being at the same temperature to start with; the acid is run in slowly from a pipette, the mixture being vigorously stirred with a thermometer, and about a minute being allowed for the addition; the temperature gradually rises to a maximum as the stirring is continued, remains nearly constant for a short time, and then falls again, the precise amount of rise depending, to some extent, on the way in which the admixture is made. When drying oils are examined, Maumené recommends dilution with olive oil, so that the temperature should not rise so high as to char the mixture (paraffin hydrocarbons are regarded by other experimenters as preferable); further, he recommends that trials should be made with different proportions of oil and acid, *e.g.*, †

50 grammes oil to 18 c.c. acid.
50 " " 36 "
100 " " 18 "

* Pure "monohydrated" sulphuric acid, H_2SO_4 , cannot be obtained by evaporation; when a strength of 98 to 98.5 per cent. is attained, the temperature rises to a point where the substance dissociates into water and sulphur trioxide, the latter passing off at the same rate as the water vapour, so that acid of that strength distils unchanged. Pure H_2SO_4 may be obtained by adding the calculated amount of SO_3 to oil of vitriol, strengthened by evaporation as far as possible; or by chilling the acid, and draining off the unfrozen mother liquor from the crystals of H_2SO_4 that form. When heated, SO_3 is evolved, and acid of about 98 per cent. left, which then distils unchanged.

† *Comptes Rendus*, xxxv., p. 572; also *Journ. Soc. Chem. Ind.*, 1886, p. 361.

The following table exhibits some of Maumené's results, together with those subsequently obtained by others; numerous other analogous values have been recorded, exhibiting more or less marked differences according to the particular mode of manipulation adopted:—

	Maumené.	Allen.	Baynes.	Archbutt.
	Degrees.	Degrees.	Degrees.	Degrees.
Menhaden oil,	126	...	123 to 128
Cod liver oil,	102 to 103	113	116	...
Linseed oil,	103	104 to 111	104 to 124	...
Walnut oil,	101
Hemp seed oil,	98
Seal oil,	92
Whale oil, northern,	91
Whale oil, southern,	92
Poppy seed oil,	74	86 to 88
Cotton seed oil, crude,	67 to 69	...	70
Cotton seed oil, refined,	74 to 75	77	75 to 76
Arachis oil,	67	47 to 60
Beechnut oil,	65
Rape and colza oils,	57 to 58	51 to 60	60 to 92	55 to 64
Almond oil,	52 to 54	...	35	...
Horse foot oil,	51
Tallow oil,	41 to 44
Lard oil,	41
Sperm oil,	45 to 47	...	51
Bottlenose oil,	41 to 47	...	42
Olive oil,	42	41 to 43	40	41 to 45
Castor oil,	47	65	...	46
Neat's foot oil,	43
Oleic acid,	38·5	...	37·5

Obviously, an admixture of rape oil with linseed oil, or *vice versa*, may be characterised with some degree of precision (the former yielding a value of little more than half that given by the latter), when the suspected sample is examined *side by side with samples of known purity* mixed in known proportions (*e.g.*, 2 to 1, equal proportions, or 1 to 2, and so on). Similarly with olive oil admixed with arachis oil, or with cotton seed oil; or sperm oil mixed with fish oil. According to Archbutt, olive oil exposed to sunlight for some time develops considerably more heat with sulphuric acid than the same oil kept in the dark; 52·5 rise of temperature being noted by him instead of 41·5.

A yet greater difference was observed by Ballantyne in the case of olive oil exposed to light for six months, and agitated daily so as to promote aerial oxidation (67° instead of 44°), analogous differences being also observed with several other kinds of oils similarly treated (p. 131).

Specific Temperature Reaction.—In order to render the thermal test practically independent of variations in the strength

of the sulphuric acid used, Thomson and Ballantyne* make simultaneously a comparative valuation with water, and calculate the ratio between the heat developed with the oil examined and that with the water; the resulting ratio they term the *specific temperature reaction*. Thus the following figures were obtained with acid of different strengths, showing a considerably closer concordance between the "specific temperature reactions" than between the uncorrected values first obtained with the different strengths of acids; of course, *exact* agreement is not to be expected, as the heat development in the case of an oil is not brought about solely by the mere physical admixture, but is also influenced by the chemical changes set up, which necessarily are apt to vary with the strength of the acid:—

Substance Used.	Sulphuric Acid of 95.4 per cent. H ₂ SO ₄ .		Sulphuric Acid of 96.8 per cent. H ₂ SO ₄ .		Sulphuric Acid of 99 per cent. H ₂ SO ₄ .	
	Rise in Temperature.	Specific Temperature Reaction.	Rise in Temperature.	Specific Temperature Reaction.	Rise in Temperature.	Specific Temperature Reaction.
	Degrees C.		Degrees C.		Degrees C.	
Water, .	38.6	100	41.4	100	46.5	100
Olive oil, }	36.5	95	39.4	95	44.8	96
	34.0	88	38.1	92	44.2	95
	39.0	94	43.8	94
Rape oil, .	49.0	127	58.0	124
Castor oil, .	34.0	88	37.0	89
Linseed oil, .	104.5	270	125.2	269

The following values for the specific temperature reactions of various kinds of oils were thus determined:—

Nature of Oil.	Specific Temperature Reaction Water = 100.
Olive oil (13 kinds examined),	89 to 95
Cotton seed oil (crude),	163
" (refined—2 kinds),	169 to 170
Rape oil (5 kinds),	125 to 144
Arachis oil (commercial),	137
" (refined),	105
Linseed oil (4 kinds),	270 to 349
Castor oil (2 kinds),	89 to 92
Southern sperm oil,	100
Arctic sperm oil (bottlenose),	93
Whale oil (pale),	157
Seal oil (4 kinds),	212 to 225
Cod oil (3 kinds),	243 to 272
Menhaden oil,	306

* *Journ. Soc. Chem. Ind.*, 1891, p. 233.

F. Jean uses a special form of apparatus, termed by him a "Thermeleometer,"* for the determination of the heat evolved in mixing sulphuric acid and oils (Fig. 32). A is a small vessel 40 mm. diameter and 60 high, enclosed in a felt-lined case, E; this holds the oil (15 c.c.) B is a U-shaped tube, holding 5 c.c. of sulphuric acid (at 65° B), furnished with a hollow glass stopper, to which is attached a piece of rubber tubing, R. V.; by blowing through the tubing the acid is forced out of the reservoir, B, and runs down on to the oil through the turned-over narrow exit pipe. T is a thermometer clamped to B. To use the instrument the acid is introduced into B by removing the stopper, and the oil run into A up to a given mark representing 15 c.c.; the oil is heated up to 40° to 50° C., the acid-holder placed in it, and the whole allowed to cool with occasional stirring to 30°; A is then placed in the casing, E, and the acid blown over into the oil, B, the attached thermometer being used as a stirrer, and the highest temperature attained read off.

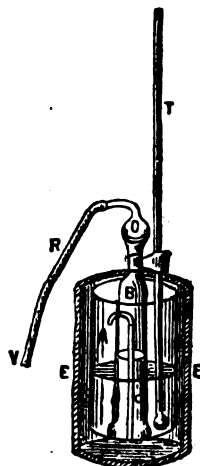

Fig. 32.

Colour Reactions produced by Sulphuric Acid.

—The table on p. 152 is given by A. H. Allen, exhibiting the effect of placing a drop or two of sulphuric acid in the centre of about twenty drops of oil, observing the colour before and after stirring.†

Some oils char more or less with sulphuric acid; in such cases, one drop of the oil may be dissolved in twenty of carbon disulphide, and one drop of sulphuric acid added. Whale oil thus treated gives a fine violet coloration, quickly changing to brown, whereas, with sulphuric acid alone, a mere red or reddish brown colour, changing to brown or black, is obtained.

Miscellaneous Colour Reactions.—Various other reagents have been proposed as colour tests for oils—*e.g.*, stannic chloride, barium polysulphide, phosphoric acid, mercuric nitrate (alone or with subsequent addition of sulphuric acid), aqua regia, caustic soda, &c. For the most part, these give but little more information than is afforded by the colour tests above described, except in some few special cases; thus, linseed oil boiled with caustic soda gives a yellowish emulsion, but if fish oils are present, a

* *Journ. Soc. Chem. Ind.*, 1890, p. 113; from *Pharm. Chem.*, 1889, xx., p. 337.

† Various modifications of the colour test proposed in 1861 by Chateau (by mixing oils with sulphuric acid) have been suggested by different observers; in some cases the test produced is subject to considerable variation, according to the amount of acid used relatively to the oil, and its strength.

reddish colour results. A solution of silver nitrate in alcohol (2 parts nitrate to 12 of water, 88 parts alcohol added to the liquid), when heated with about five times its volume of oil, is

OIL	Before Stirring.	After Stirring.
<i>Vegetable Oils.</i>		
Olive oil, . . .	{ Yellow, green, or pale brown.	{ Light brown or olive green.
Almond oil, . . .	{ Colourless or yellow.	{ Dark yellow, olive, or brown.
Arachis oil, . . .	{ Greyish yellow to orange.	{ Greenish or reddish brown.
Rape oil (crude),	{ Green with brown rings.	{ Bright green, turning brownish.
„ (refined),	{ Yellow with red or brown rings.	{ Brown.
Mustard oil, . . .	{ Dark yellow with orange streaks.	{ Reddish brown.
Cotton seed oil (crude),	{ Very bright red.	{ Dark red, nearly black.
„ (refined),	{ Reddish brown.	{ Dark reddish brown.
Niger seed oil, . . .	{ Yellow with brown clot.	{ Reddish or greenish brown.
Poppy seed oil, . . .	{ Yellow spot with orange streaks or rings.	{ Olive or reddish brown.
Linseed oil (raw),	{ Hard brown or greenish brown clot.	{ Mottled, dark brown.
„ (boiled), . . .	{ Hard brown clot.	{ Mottled, dark brown.
Castor oil, . . .	{ Yellow to pale brown.	{ Nearly colourless or pale brown.
<i>Animal Oils.</i>		
Lard oil, . . .	{ Greenish yellow or brownish with brown streaks.	{ Mottled or dirty brown.
Tallow oil, . . .	{ Yellow spot with pink streaks.	{ Orange red.
Whale oil, . . .	{ Red, turning violet.	{ Brownish red, turning brown or black.
Seal oil, . . .	{ Orange spot with purple streaks.	{ Bright red, changing to mottled brown.
Cod liver oil, . . .	{ Dark red spot with purple streaks.	{ Purple, changing to dark brown.
Sperm oil, . . .	{ Pure brown spot with faint yellow ring.	{ Purple, changing to reddish or dark brown.
<i>Hydrocarbon Oils.</i>		
Petroleum lubricating oil,	{ Brown.	{ Dark brown with blue fluorescence.
Shale lubricating oil, . . .	{ Dark reddish brown.	{ Reddish brown with blue fluorescence.
Rosin oil (brown),	{ Bright mahogany brown.	{ Dark brown with purple fluorescence.
„ (pale), . . .	{ Mahogany brown.	{ Red-brown with purple fluorescence.

Name of Oil.	Nitric Acid.		Sulphuric acid.	Nitric and Sulphuric Acids mixed.	Caustic Soda or Potash. Sp. Gr., 1.33.	Zinc Chloride (Syrupy).	Hydrochloric Acid and Sugar.
	Sp. Gr., 1.18 to 1.20.	Fuming, Sp. Gr. 1.45.	Sp. Gr., 1.00 to 1.70.				
Almond,	Pale red.	Reddish.	Olive green.	Reddish.	Grey white.	White.	Orange yellow.
Arachis,	Reddish yellow.	Red yellow.	Brown.	Reddish yellow.	Flesh coloured.	Brownish.	Yellow.
Bancknut,	Yellowish.	Red yellow.	Yellow.	Red brown.	Yellowish.	Flesh red.	..
Beechnut,	Yellow.	Red brown.	Reddish.	Yellowish.
Brazilnut (Para nut),	Brown.	Brown.	Brownish yellow.	White.	Rose red.	Brownish.
Charlock seed,	Yellow.	Brown.	Brown.	Red brown.	Yellow.	Dark yellow.	..
Castor,	Yellowish.	Yellow.	Red yellow.	Yellow.	White.	White.	Yellow orange.
Camelina,	Red.	Dirty brown.	Orange.	Brownish red.	Yellow.	Green.	..
Cotton seed,	Orange brown.	Purple red.	Red.	Yellow.	Brown.	Yellow orange.
Cod liver,	Blood red, brown red.	Violet.	Red brown.	Red.	..	Brown.
Colza (crude, (rape), (refined),	Yellowish.	Brown red.	Dirty greenish brown	Reddish yellow.	Yellowish.	Blue green.	Brownish green.
Fish,	Brown.	Green brown.	Reddish yellow.	White.	Yellowish.	..
Hemp seed,	Grey green.	Dark green.	Greenish.	Brown.	Red.
Hazelnut,	Yellow.	Blue green.	Green.	Finally black.	Greenish yellow.	Green yellow.	Yellow greenish.
Linseed,	Cadmium yellow.	Cherry brown.	Green.	Blue greenish.	Yellowish.	Grey green.	..
Madia,	Brownish red.	Grey green.	Green brown.	Yellow.	Bright yellow.	Yellow.
Maize,	Red yellow.	Brown.	Dark green.	Dirty brownish.	Yellowish.
Mustard (white, seed, (black, seed, (black,	Yellowish.	Cherry red.	Greenish brown.	Red yellow.	Yellowish.	Yellow green.	..
Neat's foot,	Yellowish.	Brown yellow.	Blue green.	Greenish yellow.	White yellow.	Grey green.	Greenish.
Olive, (inferior, (superior),	Bright green.	Dirty brownish.	Green.	Green.	White.	Light rose.	Yellow orange.
Peach kernel,	Reddish yellow.	Peach, blood red.	Olive green.	Peach, blood red.	Dirty white.	Greenish.	Brownish.
Poppy seed,	Greenish.	Yellow red.	Greenish brown.	Red.	Yellow.	Dark yellow.	..
Radish seed,	Red.	Brown red, blood red.	Grey yellow.	Yellowish.	Grey greenish.	Orange yellow.
Seal,	Red brown.	..	Reddish brown.	Red.	..	Grey.
Sesamé,	Yellow red.	Reddish brown.	Green.	Green.	Whitish.	..	Violet.
Sunflower seed.,	Reddish brown.	Bluish green.	Dirty brownish.	White.
Whale (train oil),	Brown.	Black brown.	Black brown.	Dirty brown.	Red.	..	Reddish.

more or less reduced in many cases, developing a brownish red, brown, or black colour; * cotton seed, bitter almond, hemp, linseed, neat's foot, and colza oils show the reaction most markedly, especially the first named.

The table on p. 153 (by Schädler) exhibits synoptically the results of various reagents on several of the more commonly occurring oils, &c.; the test with hydrochloric acid and sugar is made by mixing equal quantities of the oil to be examined and hydrochloric acid of specific gravity 1.125 (about 1 c.c. of each), adding a gramme of cane sugar, and shaking vigorously for some time.

SULPHUR CHLORIDE REACTION. VULCANISED OILS.

The use of sulphur chloride in "vulcanising" india-rubber" is well known; a somewhat analogous change takes place when this substance (preferably diluted with light petroleum oil, carbon disulphide, or other suitable solvent) is intermixed with certain oils, more especially linseed oil; solidification ensues, with the result of forming a more or less leathery mass, which is employed to some considerable extent in the manufacture of insulating coverings for electric mains and leads, and similar purposes. During the action considerable quantities of hydrochloric acid are evolved, whilst the final product contains sulphur, some of which is in a condition insoluble in carbon disulphide, apparently combined with the oil constituents; so that the chemical action of sulphur chloride appears to be of a far more deep-seated nature than that of nitrous acid (elaidin reaction), where the solidification appears to be due simply to polymerisation or isomeric re-arrangement of atoms. Although no true oxidation takes place during the treatment, the term "oxidised oil" is often applied to this product in the trade, probably because the solidification brought about is somewhat akin in appearance to that effected when drying oils are oxidised by exposure to air, forming solid products.

Another kind of "vulcanised oil" is obtained by mixing flowers of sulphur with the oil to be treated, and then applying heat, much as in the process of vulcanising india-rubber. In some cases the oils are previously partly saponified. By heating linseed oil to about 230° C., cooling to 176° C. (350° F.), and then stirring in sulphur, an india-rubber like mass is finally obtained, useful in the preparation of rubber substitutes. As with sulphur chloride, hydrogen appears to be removed during the process, sulphuretted hydrogen freely escaping; this renders the manufacture an especially fetid one unless great care be taken to destroy the evil-smelling vapours evolved, by causing

* Cruciferous oils containing sulphur form black silver sulphide by this treatment.

them to pass through a furnace before escaping into the factory chimney, or some analogous treatment.

The effect of chloride of sulphur (diluted with carbon disulphide) upon oils of various kinds is so far different that in certain cases it may be employed to discriminate one from another, or to test for admixture; as in all other analogous cases, comparison of the sample tested with genuine oils, treated side by side, is necessary in order to obtain reliable results. Bruce Warren finds* that when 5 grammes of oil are mixed with 2 c.c. of carbon disulphide and 2 of a mixture of equal volumes of carbon disulphide and yellow sulphur chloride (free from dissolved sulphur) and the whole heated on a waterbath till action commences, the products formed (after evaporating off carbon disulphide) differ in weight and character according to the nature of the oil, being partly soluble in carbon disulphide and partly insoluble therein. Thus poppy seed and linseed oils gave the following figures (5 grammes used in each case):—

	Poppy Seed.	Linseed.	Mixture of Equal Quantities of the Two.
Soluble, . . .	1·96	0·78	1·10
Insoluble, . . .	4·50	5·58	5·37
Total, . . .	6·46	6·36	6·47

C. A. Fawsitt † employs sulphur chloride, S_2Cl_2 , purified by distillation, in the proportion of 2 c.c. to 30 grammes of oil, operating as in the case of Maumené's sulphuric acid test; very considerable differences are observed with different oils as regards the amount of heat evolved, the rate of its evolution, and the formation or otherwise of hydrochloric acid gas; thus, the following figures were obtained, *inter alia*.

Name of Oil.	4 c.c. Sulphur Chloride to 30 grms. Oil.			
	Gas Evolution.	Rise in Temperature.	Time in Rising.	Rise per Minute.
		Degrees C.	Minutes.	
Sperm, . . .	Very small.	71	8	8·8
Seal, . . .	None.	112	5	22·4
Whale, . . .	Slight.	91	3	30·2
Neat's foot, . . .	"	82	4	20·5
Rape, . . .	None.	89	6	14·8
Cotton seed, . . .	Slight.	93	6	15·4
Linseed, . . .	Considerable.	97	2	48·7
Olive, . . .	Slight.	94	4	23·5
Cod liver, . . .	Abundant.	103	3	34·3
Palmnut, . . .	Slight.	9	7	1·4
Oleic acid, . . .	Considerable.	99	6	16·5
Stearic acid, . . .	None.	8	5	1·6

* *Chemical News*, 1888, 57, p. 113. † *Journ. Soc. Chem. Ind.*, 1888, p. 552.

Name of Oil.	2 c.c. Sulphur Chloride to 30 grms. Oil.			
	Gas Evolution.	Rise in Temperature.	Time in Rising.	Rise per Minute.
		Degrees C.	Minutes.	
Sperm, . . .	Very small.	37	16	2.3
Seal, . . .	None.	45	10	4.4
Whale, . . .	Slight.	57	6	9.4
Neat's foot, . . .	"	51	7	7.3
Lard, . . .	"	40	16	2.4
Rape, . . .	None.	53	10	5.3
Cotton seed, . . .	Slight.	49	11	4.4
Linseed, . . .	Considerable.	57	5	11.4
Olive, . . .	Slight.	52	6	8.7
Castor, . . .	Abundant.	56	2	27.7
Cod liver, . . .	"	55	4	13.7
Palm, . . .	"	35	3	11.6
Palmnut, . . .	Slight.	5	9	0.5
Rosin, . . .	Abundant.	31	7	4.4
Oleic acid, . . .	Considerable.	53	6	10.6
Stearic acid, . . .	None.	5	7	0.7

It would hence seem that the relative figures obtained with a given pair of oils often vary considerably according as 2 or 4 c.c. of sulphur chloride are used; so that the value of the test as applied to mixtures is somewhat doubtful.

CHAPTER VIII.

QUANTITATIVE REACTIONS OF OILS, &c.

A VARIETY of quantitative chemical tests are in use with the object of obtaining information on various points connected with the general chemistry of fatty matters, so as to afford evidence in cases of suspected adulteration, &c. Some of these depend on the occurrence of saponification changes; others on different principles. Amongst them may be reckoned the determination of the amount of unsaponifiable matter present effected, as described on p. 119, and the valuation of the amount of free fatty acids present, not contained as glycerides (*vide* p. 116); in addition to these, the following tests are also more or less frequently employed, named after the various chemists who have proposed them:—

1 *Kattstorfer's Test*.—Determination of the amount of potash

(KOH, equivalent 56.1) requisite to saponify 1,000 parts of substance—*i.e.*, the permillage of potash requisite for saponification.

2. *Hehner's Test.*—Determination of the percentage of fatty acids formed, insoluble in hot water.

3. *Reichert's Test.*—Determination of the proportion of acids formed, volatile with the steam of water when distilled under certain arbitrary conditions.

4. *Hübl's Test.*—Determination of the quantity of iodine capable of direct combination with 100 parts of substance.

5. *Benedikt and Ulzer's Test.*—Determination of amount of acetic acid formed by acetylating substances containing alcoholic hydroxyl, and saponifying the product; expressed as permillage of potash, equivalent to the acetic acid thus formed, reckoned per 1,000 parts of acetylated product.

6. *Zeisel's Test.*—Determination of amount of silver iodide formed from the alkyl iodide (methyl, ethyl, &c., iodide), evolved on heating with hydriodic acid; expressed as the weight of methyl ($\text{CH}_3 = 15$), equivalent to the silver iodide thus formed from 1,000 parts of substance.

KÆTTSTORFER'S TEST—TOTAL ACID NUMBER.

Owing to the different molecular weights of the various fatty acids contained in glycerides and compound ethers, it necessarily results that equal weights of different substances are chemically equivalent to different amounts of alkali—*i.e.*, that the quantities of caustic potash, for example, requisite to bring about the saponification reaction

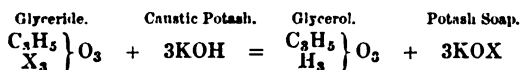

vary with the nature of X when equal weights of fatty matter are used throughout. The greater the molecular weight of X, the less potash will be requisite to saponify a given weight. The quantity of caustic potash requisite for saponification, being a measure of the molecular weight of the fatty glycerides, &c., present, has been shown by Kættstorfer to afford in many cases a useful means of checking the nature and purity of the oil, &c., examined. The weight of potash (KOH = 56.1) thus consumed by 1,000 parts of substance (milligrammes of potash per gramme) is accordingly known as the "Kættstorfer number," (*Verseifungszahl*); or otherwise as the "total acid potash permillage" or "total acid number" of the oil, &c., examined. The determination of this value is effected in somewhat the same fashion as that of the "free acid number" above described

(p. 116), by saponifying the oil with an excess* of alcoholic potash, and back-titrating the unneutralised surplus; in this way the potash consumed represents not only the free fatty acid present but also that liberated during saponification—i.e., the *total* fatty acids present—whence the name.

Knowing the total acid number (Kættstorfer number), K of a given substance, the mean equivalent weight of the substance is readily calculated by the proportion

$$K : 56.1 :: 1,000 : x = \frac{56,100}{K}.$$

The value of x thus deduced is generally referred to as the "*saponification equivalent*" of the body in question.

Substance.	Chief Sources.	Total Acid Number, or Kættstorfer Number (Percentage of Potash required for Saponification, &c.).	Saponification Equivalent.
<i>Glycerides.</i>			
Tributyryn, .	Butter fat,	557.3	100.7
Trivalerin, .	Porpoise, dolphin, and whale oils,	489.2	114.7
Trilaurin, . .	Cokernut and palmnut oils,	263.8	212.7
Tripalmitin, .	Palm oil, lard,	208.8	268.7
Tristearin, .	Tallow, lard, cacao butter,	189.1	296.7
Triolein, . .	Olive and almond oils,	190.4	294.7
Trierucin, .	Coiza and rape oils.	160.0	350.7
Trilinolin, .	Linseed, hemp, and walnut oils,	191.7	292.7
Triricinolein, .	Castor oil,	180.6	310.7
<i>Compound Ethers.</i>			
Cetyl palmitate,	Spermaceti,	116.9	480
Myricyl palmitate,	Beeswax,	83.0	676
Ceryl cerotate, .	Chinese wax,	71.2	788
Dodecatyl oleate,	Sperm oil,	124.7	450
Dodecatyl doeglate, .	Bottlenose oil,	120.9	464

The foregoing table represents the total acid numbers and saponification equivalents of various triglycerides and compound ethers of frequent occurrence; in the case of glycerides the molecular weight is three times the saponification equivalent, whilst with compound ethers of monohydric alcohols it is identical therewith.

Classification of Oils, &c., by Means of their Saponification Equivalents.—The table on p. 159 has been arranged by

* Unless a more or less considerable excess be used, it is very difficult to ensure complete saponification.

Nature of Oil.	Percentage of KOH required for Saponification.	Saponification Equivalent.
A. OLEINES—		
Lard oil,	19.1 to 19.6	} 285 to 296
Olive oil,	18.93 to 19.6	
Sweet almond oil,	19.47 to 19.61	
Arachis oil,	19.13 to 19.66	
Tea oil,	19.55	
Seamé oil,	19.00 to 19.24	
Cotton seed oil,	19.10 to 19.66	
B. RAPE OIL CLASS—		
Colza oil,	17.08 to 17.90	} 313 to 330
Rape oil,	17.02 to 17.64	
Mustard seed oil,	17.4	
Cabbage seed oil,	17.52	
C. VEGETABLE DRYING OILS—		
Linseed oil,	18.74 to 19.52	} 286 to 300
Poppy seed oil,	19.28 to 19.46	
Hemp seed oil,	19.31	
Walnut oil,	19.60	
Niger seed oil,	18.9 to 19.1	
D. MARINE OLEINES—		
Cod liver oil,	18.51 to 21.32	} 250 to 303
Menhaden oil,	19.20	
Pilchard oil,	18.6 to 18.75	
Seal oil,	18.9 to 19.6	
Southern whale oil,	19.31	
Northern whale oil,	18.85 to 22.44	
Porpoise oil,	21.60 to 21.88	
E. BUTTER CLASS—		
Butter fat,	22.15 to 23.24	241 to 253
Cokernut oil,	24.62 to 26.84	} 209 to 255
Palmnut oil,	22.00 to 24.76	
F. STEARINES, &C.—		
Lard,	19.20 to 19.65	} 277 to 294
Tallow,	19.32 to 19.80	
Dripping,	19.65 to 19.70	
Butterine,	19.35 to 19.65	
Goose fat,	19.26	
Bone fat,	19.06 to 19.71	
Palm oil,	19.63 to 20.25	
Cacao butter,	19.98	
G. FLUID WAXES—		
Sperm oil,	12.34 to 14.74	380 to 454
Bottlenose oil,	12.30 to 13.40	419 to 456
H. SOLID WAXES—		
Spermaceti,	12.73 to 13.04	432 to 441
Beeswax,	9.2 to 9.7	...
Carnauba wax,	7.9 to 8.51	...
I. UNCLASSIFIED—		
Shark liver oil,	14.00 to 19.76	284 to 400
Wool fat (suint),	17.0	330
Olive kernel oil,	18.85	298
Castor oil,	17.6 to 18.15	309 to 319
Japanese wood oil,	21.1	266
Japan wax,	21.01 to 22.25	252 to 267
Myrtle wax,	20.57 to 21.17	265 to 273
Blown rape oil,	19.8 to 20.4	275 to 284
Colophony,	17.0 to 19.3	290 to 330

A. H. Allen* representing the percentages of caustic potash required for the saponification of most of the usually occurring oils, &c., deduced by collecting together the published results of a number of observers, some of the values being deduced from upwards of forty different samples.

Values but little removed from these have been subsequently collected and recorded by Benedikt† and Schädler,‡ including various later valuations of the Kettstorfer's values of other oils and fats :—

Name of Oil, &c.	Schädler.	Benedikt.
Apricot kernel,	192-193	192·9
Arachis,	194-196	190·1-197
Almond, sweet,	190-192	187·9-196·1
Almond, bitter,	194·5-196·6
Butter,	225-230	227
Beeswax (yellow),	95-100	97-107
Bone oil,	190-191	...
Cacao butter,	198-200	...
Cokernut,	255-260	255
Colza,	177-178	175-179
Curcas,	230-231	230·5
Charlock,	176-177	...
Castor,	201-203	176-181·5
Carnauba wax,	79
Cotton seed,	194-195	191-210·5
Cod liver, medicinal,	175-185	} 171-213·2
Cod liver, brown,	180-200	
Galam butter,	192-193	...
Gundscht (lallelantia),	184-185	185·0
Hemp seed,	192-194	193·1
Hedge radish,	176-177	174·0
Japanese wax,	222-223	...
Linseed oil,	190-192	187·4-195·2
Lard,	195-196	...
Malabar tallow (pinye tallow),	191-192	...
Menhaden,	192
Maize,	188-189	188·1-189·2
Neat's foot,	191-193	...
Niger,	189-191	189-191
Nut (Walnut),	196-197	196·0
Olive, salad,	191-193	} 185·2-196
Olive, inferior,	186-188	
Olive kernel,	188-189	
Poppy,	193-194	188·5
Palm,	201-202	192·8-194·6
Palm kernel,	246-248	...
Pumpkin seed,	189-190	257·6
		189·5

* *Commercial Organic Analysis*, vol. ii., p. 41, *et seq.* The "percentage of caustic potash requisite" is obviously *one-tenth of the Kettstorfer number*, or permillage of potash necessary for saponification.

† *Analyse der Fette und Wachsarten*, pp. 294 and 317.

‡ *Untersuchungen der Fette Oele und Wachsarten*, pp. 134, 135.

Name of Oil, &c.	Schädler.	Benedikt.
Porpoise,	143.9
Pilchard,	Fluid portion 263.0
Shark liver oil,	186-187.5
Seal oil,	84.5
Sesamé,	180-195	191-196
Sunflower,	192-193	187.6-192.2
Spermaceti,	193-194	193
Sperm oil,	108	108.1
Suet (ox tallow, beef tallow),	134	132.2
Tallow (sheep),	193-195	...
Tacamahac,	192-195	...
Unguadia,	199-200	...
Whale,	190-192	...
Whale, bottlenose,	190-191	190-191
Woolgrease,	197.3
	169-170	Fluid portion 290.0
		...

Practical Determination of Saponification Equivalents of Glycerides, &c.—A known weight of the substance to be examined (conveniently 2 or 3 grammes) is accurately weighed up in a flask, and 25 c.c. (or other suitable quantity) of standard alcoholic potash added (approximately seminormal); this should be made from alcohol—not methylated spirit—that has been cohobated with caustic potash, and distilled so as to remove as far as possible all compound ethers and other impurities that might be resinised by potash, or otherwise partially neutralise alkali; methylic alcohol of high purity may be similarly used, preferably after the same treatment. The whole is heated on a waterbath with a reflux condenser attached, and gently agitated at intervals until complete solution has taken place; after a few minutes more heating to ensure that saponification is complete, the unneutralised alkali is titrated by seminormal standard acid (preferably hydrochloric), using phenolphthalein as indicator. The standardising of the alcoholic potash in terms of the acid is preferably effected by heating 25 c.c. on the waterbath, with an inverted condenser attached, *side by side with the oil examined*, and subsequently titrating; the difference between the acid required in the two cases thus directly represents the acid equivalent to that formed by the saponification. If *w* be the weight in milligrammes of oil taken, and *n* the number of c.c. of normal acid equivalent to the acid formed by saponification (*i.e.*, if 2*n* c.c. of seminormal acid be used, 10*n* of decinormal, and so on), then the saponification equivalent *E* is given by the equation *

$$E = \frac{w}{n}$$

* 1 c.c. of "normal" acid represents *E* milligrammes of fat, whence *n* c.c. of acid are equivalent to *nE* milligrammes. Since this quantity = *w*,

and the total acid number (Kœttstorfer number = permillage of potash, or tenfold the percentage, requisite for saponification) by the equation

$$K = \frac{n}{w} \times 56,100.$$

The determination of the total acid number is generally combined with that of the free acid number; the weighed quantity of fat, &c., mixed with a little warm alcohol, is titrated with alcoholic alkali, using phenolphthalein as indicator, so as to determine the free acid number (see p. 116); excess of alkali is then added and the determination of the total acid number proceeded with. Thus, suppose that 2.501 grammes (2,501 milligrammes) of Japanese wax contain sufficient free fatty acid to neutralise 2.5 c.c. of seminormal alkali (equal to 1.25 c.c. of normal solution); whilst after adding excess of alkali, saponifying, and back-titrating, 19.0 c.c. of seminormal fluid (equal to 9.5 c.c. normal) are neutralised in all; then the free acid and total acid numbers are respectively $\frac{1.25}{2,501} \times 56,100 = 28.04$, and

$$\frac{9.5}{2,501} \times 56,100 = 213.1; \text{ whilst the saponification equivalent is } \frac{2,501}{9.5} = 263.3.$$

If A be the free acid number, and K the total acid number (Kœttstorfer number), the quantity $K - A$ is a measure of the proportion of compound ethers (esters, glycerides, &c.) present in the substance examined, and may be conveniently termed the *ester number* (*Esterzahl*, *Etherzahl*); thus in the above instance the ester number is $263.3 - 28.04 = 235.26$. In general, if m c.c. of normal alkali are consumed in neutralising the free acid present in w milligrammes of substance, and n c.c. in neutralising the total acids, the value of the ester number, $K - A$, is given by the equation

$$\begin{aligned} K - A &= \frac{m}{w} \times 56,100 - \frac{n}{w} \times 56,100 \\ &= \frac{m - n}{w} \times 56,100. \end{aligned}$$

In the case of triglycerides, the quantity of glycerol theoretically obtainable from a given weight of substance is readily

it results that $E = \frac{w}{n}$. On the other hand, 1 c.c. of normal acid represents 56.1 milligrammes of KOH, whence n c.c. are equivalent to $n \times 56.1$ milligrammes. Then $w : n \times 56.1 :: 1,000 : K = \frac{n}{w} \times 56,100$.

deduced from the ester number: 3×56.1 parts of potash neutralised by the acids liberated from the triglycerides, represent 92 parts of glycerol set free: hence, if S is the ester number, the glycerol produced is $\frac{92}{168.3} \times S = 0.5466 \times S$ per mille, or $.05466 \times S$ per cent.; thus, a sample of groundnut oil, yielding the total acid number 195.0, and the free acid number 5.0, and consequently the ester number $195.0 - 5.0 = 190.0$, would theoretically yield $190.0 \times .05466 = 10.39$ per cent. of glycerol.

Proportion of Fatty Acids formed by Saponification.—Just as the average molecular weight of a mixture of triglycerides or other compound ethers will depend partly on the molecular weights of the fatty acids formed by saponification, and partly on those of the alcoholic or glyceridic constituents, so will the percentage of fatty acids obtainable vary in like manner. In the case of a mixture of glycerides, where some of the fatty acids are of low molecular weight, obviously a smaller percentage of fatty acids will be formed than would be were all the fatty acids of higher molecular weight. Thus, 100 parts of butyrin, $C_4H_9(O.C_4H_7O)_3$, would theoretically yield 87.4 of butyric acid; whilst 100 parts of stearin, $C_{18}H_{35}(O.C_{18}H_{35}O)_3$, would similarly furnish 95.7 parts of stearic acid.

In certain cases, useful information is obtainable by determining the total percentage of fatty acids actually produced, more especially when, in addition to the total percentage, the amounts respectively *soluble* and *insoluble in water* are also deduced; the information being in some cases further supplemented by determining the amount and nature of alcoholic or glyceridic complementary products.

The total percentage of fatty acids can be reckoned from the amount of alkali requisite for saponification (the Kættstorfer number determined as indicated on p. 161) if the mean equivalent of the fatty acids is known; more usually, however, the latter is the principal point to be examined, and the percentage of acids requires to be directly determined; from which value, together with the quantity of alkali used, the mean equivalent weight of the fatty acids is deduced. Thus, if 100 parts by weight of substance yield a weight, w_1 , of fatty acids (*i.e.*, if w_1 be the percentage of fatty acids found), and w_2 parts of potash, KOH, be required to neutralise these acids, the mean equivalent weight of the acids is given by the proportion—

$$w_2 : 56.1 :: w_1 : x = \frac{w_1}{w_2} \times 56.1.$$

If K be the total acid number (permillage of KOH, or ten times the percentage) the mean equivalent weight of the fatty acids will obviously be—

$$x = \frac{w_1}{\frac{1}{10} K} \times 56.1 = \frac{w_1}{K} \times 561.$$

The term *neutralisation number of the fatty acids* (*Verseifungszahl der Fettsäuren*) is conveniently employed to indicate the quantity of potash (KOH = 56.1) neutralised by 1000 parts of the free acids. This value and the mean equivalent weight of the free acids are related to one another in a fashion similar to that exhibited by the total acid number, and the saponification equivalent of the original fat or oil; if N be the neutralisation number of the free acids, and F their mean equivalent weight (value of x as above), then

$$N : 56.1 :: 1000 : F,$$

whence

$$N = \frac{56,100}{F}$$

and

$$F = \frac{56,100}{N}$$

The following table represents the average *neutralisation numbers of the free fatty acids* obtained from various kinds of oils, &c.—i.e., the quantities of potash (KOH = 56.1) neutralised by 1,000 parts of mixed free fatty acids (Schädler):—

Name of Oil, &c.	Neutralisation Number.
Almond,	204-205
Arachis,	196-197
Cotton seed,	204-205
Castor,	187-188
Cod liver (medicinal),	202-204
Charlock,	180-181
Colza,	181-182
Linseed,	198-199
Lard,	215-217
Nut (walnut),	208-209
Olive,	199-200
Palm,	206-207
Palm kernel,	265-266
Poppy,	204-205
Suet (ox),	205-206
Sesamé,	197-198
Sunflower,	201-202
Tallow (sheep),	206-207

In the case of a triglyceride, the calculated saponification equivalent of the glyceride always exceeds the equivalent weight of fatty acids produced from it by saponification by 12.67; for the general reaction of saponification being equivalent to

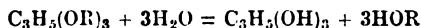

where R is a fatty acid radicle, it results that the molecular weight (three times the equivalent) of the glyceride, G, plus $3 \times 18 = 54$ parts of water, is identical with the molecular

weight of glycerol = 92, plus three times the equivalent weight of the fatty acid formed by saponification, $3F$; whence,

$$G = 3F + 92 - 54,$$

and

$$\frac{G}{3} = F + 12.67.$$

In similar fashion, in the case of a mixture of a triglyceride and the fatty acid contained therein (*e.g.*, tristearin and stearic acid), the mean saponification equivalent of the mixture will exceed the equivalent of the fatty acid by a fraction of the number 12.67, expressing the proportion of fatty acid contained as glyceride to the total fatty acid present. If S be the ester number, and K the total acid number, this fraction is $\frac{S}{K}$; whence, the mean saponification equivalent of the mixture, M , is given by the equation

$$M = F + \frac{S}{K} \times 12.67.$$

Thus, supposing the free acid number to be 5 per cent. ($\frac{1}{20}$) of the total acid number, so that the ester number is 95 per cent. ($\frac{19}{20}$) thereof, the relationship between M and F will be

$$\begin{aligned} M &= F + \frac{19}{20} \times 12.67, \\ &= F + 12.04. \end{aligned}$$

Similarly, if the free acid number be 10 per cent. ($\frac{1}{10}$) of the total acid number,

$$M = F + 11.40.$$

Hence, as in the case of most oils and fats, the amount of free acid is only a few per cents. of that of the total acids, it may be taken as a general rule that *the mean saponification equivalent of a natural oil or fat exceeds the mean equivalent of the fatty acids contained therein by about 12*; and by a proportionately less amount when the quantity of free fatty acid present increases beyond a few per cents.

This relationship enables comparisons to be readily instituted between the values deduced by the saponification of a fat or oil, and by titrating of the fatty acids separated therefrom, when expressed as equivalents; whereas, such comparisons are much less readily made by means of the potash permillages directly obtained, *viz.*, the "total acid number" of the glyceride, and "neutralisation number" of the free acids thence derived (p. 164).

Since the saponification equivalent of a triglyceride exceeds the equivalent weight of the fatty acid contained therein by

12·67, it results that for fatty glycerides, where the equivalent weight of the fatty acid contained lies between 250 and 330, the percentage of fatty acid yielded by the glyceride lies between

$$\frac{250}{250 + 12\cdot67} \times 100, \text{ and } \frac{330}{330 + 12\cdot67} \times 100, \text{ i.e., between } 95\cdot2$$

and 96·3; so that, for the great majority of natural oils and fats containing only small quantities of free fatty acids, the rest being glycerides, the yield of fatty acid per 100 parts of fat is close to 95·75 parts. Fats containing a considerable amount of glycerides of relatively low molecular weight, such as butter fat, cokernut butter, and palm kernel oil, &c., yield proportionately smaller percentages of fatty acids; on the other hand, if much free fatty acid is present in the fat or oil examined, the percentage yield of fatty acids from the mixture is proportionately increased.

HEHNER'S TEST.

This test consists in determining that fraction of the fatty acids formed on saponification and acidulation which remains undissolved in hot water, repeatedly applied until no more acid is dissolved. With most oils and fats this quantity differs but little from the total percentage (about 95·5 to 96 per cent. as a rule, *supra*)—i.e., only minute quantities of soluble fatty acids are present; but with cow's butter, cokernut butter, and some few other substances the difference is much greater. Thus with butter fat the total percentage is usually from 93 to 94, whilst the percentage of insoluble acids (the Hehner number) is only 87 to 88. With the fatty glycerides employed in the manufacture of oleomargarine, the soluble acids are present in only very small quantity, so that the insoluble acids amount to 95–96 per cent.; hence, any considerable admixture of oleomargarine with genuine butter is detected by the increment in percentage of insoluble acids found.

The following table represents the proportion of genuine butter fat and foreign fats (margarine) present in a sample of mixture yielding a higher Hehner number than genuine butter fat, assuming this to give the value 87·5, and margarine to give 95·5.

The same result is also obtainable by means of the formula

$$x = (H - 87\cdot5) \times 12\cdot5,$$

where H is the observed Hehner number, and x the calculated percentage of margarine.*

* When cokernut butter (or the stearine thence isolated by chilling and pressing) is substituted for oleomargarine from beef suet, &c., the above table does not hold good.

Hehner Number Found.	Percentage Present of	
	Genuine Butter Fat.	Margarine.
87·5	100	0
88	93·75	6·25
88·5	87·5	12·5
89	81·25	18·75
89·5	75	25
90	68·75	31·25
90·5	62·5	37·5
91	56·25	43·75
91·5	50	50
92	43·75	56·25
92·5	37·5	62·5
93	31·25	68·75
93·5	25	75
94	18·75	81·25
94·5	12·5	87·5
95	6·25	93·75
95·5	0	100

Other tests depending on principles somewhat similar to those involved in Hehner's test have been proposed by other chemists for use in special cases; thus the difference in solubility of barium salts has been proposed as a criterion instead of the difference in solubility of free acids for butter analysis, &c. A modification of this principle is utilised as a means of determining the relative proportions of stearic and oleic acids in mixtures of the two based on the different solubilities of their lead salts in ether (*vide* p. 112).

PRACTICAL DETERMINATION OF THE AMOUNT OF FATTY ACIDS FORMED ON SAPONIFICATION (SOLUBLE AND INSOLUBLE IN WATER), AND THEIR AVERAGE EQUIVALENT WEIGHTS.

The neutralised alcoholic solution left after determining the saponification equivalent (or the product obtained by saponifying a larger quantity of fat, say 10 grammes, with alkali without titration) is evaporated to drive off alcohol, dissolved in hot water, and treated with an excess of acid (standardised or otherwise, according to circumstances—*vide infra*); a few minutes boiling decomposes all soap present, so that a clear layer of fused fatty acids swims up to the top on standing. A weighed filter (weighed in a dish after drying in the steam bath) is prepared and wetted with water (otherwise fatty acids may pass through), and the acidified fluid filtered through, the oily fatty acids

remaining on the filter being washed with boiling water until no more acidity is found in the filtrate. The filter is then dried inside the weighed dish, and thus the weight of insoluble acids determined. If w grammes of oil give n grammes of insoluble acids, the "Hehner number," H , or percentage of insoluble acids, is obviously

$$H = \frac{n}{w} \times 100.$$

The fatty acids thus formed are dissolved in pure alcohol and titrated with standard alcoholic alkali precisely as in the determination of the "free acid number" of an oil, &c. (p. 116). The quantity of potash (KOH = 56.1) neutralised by the insoluble fatty acids obtained from 1,000 parts of original substance is conveniently referred to as the "insoluble acid potash per-millage," or "*insoluble acid number*" of the oil, &c., examined.

The difference between the quantity of potash neutralised in the determination of the saponification equivalent (total acid number) and that thus found as the insoluble acid number, is obviously the potash equivalent to the acids present that are soluble in water; this difference is conveniently referred to as the "*soluble acid number*" of the oil, &c., tested. If the composition of these soluble acids is known or assumed (*e.g.*, regarding them as *butyric acid* in the case of butter fat), their weight is reckoned from the alkali neutralised as percentage on the original fat examined, and by adding this value to that deduced as above for the insoluble acids, the percentage of total acids formed is obtained.

For example, suppose 2,500 grammes of butter fat to be saponified with 25 c.c. of seminormal potash, and that on titrating the excess of alkali 4.9 c.c. are found to be unneutralised by the acids formed on saponification; then the total acids formed are equivalent to $25 - 4.9 = 20.1$ c.c. of seminormal alkali, or 10.05 c.c. of normal alkali. Hence the *total acid number* is

$$\frac{10.05}{2,500} \times 56,100 = 225.5,$$

and the *saponification equivalent* is

$$\frac{2,500}{10.05} = 248.8.$$

After separation of the insoluble fatty acids, these are found to weigh 2.187 grms., and to neutralise 16.6 c.c. of seminormal alkali = 8.3 c.c. of normal alkali; hence the *insoluble acid number* is

$$\frac{8.3}{2,500} \times 56,100 = 186.25;$$

the percentage of insoluble fatty acids (*Hehner number*) is

$$\frac{2,187}{2,500} \times 100 = 87.48;$$

and their *average equivalent weight* is

$$\frac{2,187}{8.3} = 263.5;$$

i.e., 1 c.c. of normal alkali neutralises 263.5 milligrammes of the mixed acids. Since the total acids neutralise 10.05 c.c. of normal alkali, and the insoluble acids 8.3 c.c., the difference = 1.75 c.c. represents the soluble acids. This corresponds with the *soluble acid number*

$$\frac{1.75}{2,500} \times 56,100 = 39.3.$$

If it be supposed that the soluble acids are essentially butyric acid (equivalent = 88), 1 c.c. of normal alkali will neutralise 88 milligrammes, and consequently 1.75 c.c. will neutralise 154 milligrammes = 6.16 per cent. of the 2,500 grms. of butter fat employed. Hence the total percentage of fatty acids formed on saponification is

Insoluble acids (Hegner number), . . .	87.48
Soluble acids (reckoned as butyric acid), . . .	6.16
Total, . . .	93.64

The mean equivalent weight of the total acids is deduced thus—

Weight of insoluble acids, . . .	2,187 milligrammes.	
„ soluble „, . . .	154 „	
	2,341 „	

Since these neutralise 20.1 c.c. of seminormal alkali, equivalent to 10.05 c.c. of normal alkali, the mean equivalent weight is

$$\frac{2,341}{10.05} = 232.9.$$

The soluble acids may also be directly estimated by employing a known quantity of standard acid to decompose the soap after determination of the saponification equivalent, and determining the acidity of the watery filtrate, using phenolphthalein as indicator. Thus, in the above case, suppose that 25 c.c. of seminormal acid were used to decompose the soap, and that 8.4 c.c. of seminormal alkali were neutralised by the watery filtrate: since the alkali present in the neutral soap represents 20.1 c.c., 25 - 20.1 = 4.9 c.c. of the acid used would remain unneutralised in the filtrate; whence, 8.4 - 4.9 = 3.5 c.c. of seminormal acid, equal to 1.75 c.c. normal, would represent the soluble acids as before. In practice, this method is less accurate than the other, as the dilution of the fluid and the unavoidable absorption of carbonic acid from the air (which interferes with phenol-

phthalein as an indicator) generally prevent so sharp a valuation being obtained.

With the exception of butter fat and allied animal fats, and cokernut and palmtree oils, the amount of soluble acids present in ordinary oils and fatty matters is usually so small as to be negligible, so that the total acid number and the insoluble acid number are sensibly identical—*i.e.*, the amount of alkali neutralised during saponification is practically identical with that neutralised subsequently by the liberated fatty acids, insoluble in water.

Correction for Anhydro derivatives, *e.g.*, Stearolactone.—Certain distilled oleines, Turkey red oils, &c., contain *stearolactone*, the “inner” anhydride of γ oxystearic acid (p. 39); when this is heated with alcoholic potash, it forms potassium oxystearate, which neutralises an equivalent of alkali ($C_{18}H_{36}O_2 = 300$); but when the resulting soap is decomposed by a mineral acid, stearolactone is reproduced. If the mixed fatty acids, &c., thus formed be titrated without heating, an insoluble acid number, corresponding with only the free fatty acids, will be indicated, the stearolactone not being converted into potassium oxystearate instantaneously in the cold; so that an *apparent existence of insoluble fatty acids is indicated* by the difference between the total acid number obtained at first, and the value obtained during the titration of the free fatty acids—*i.e.*, their apparent neutralisation number. The deficiency, however, is made up if the neutralised fatty acids, &c., be heated with excess of alcoholic potash, and then back-titrated, so as to determine the alkali neutralised by the formation of oxystearate; from the amount thus neutralised the stearolactone can be calculated. 1 c.c. of normal acid representing 282 milligrammes. Or the stearolactone may be dissolved out from the neutralised fatty acids by means of ether or benzoline, and directly weighed* (p. 119).

Corrections for Free Fatty Acids and for Unsaponifiable Matters.—If the substance examined contain free fatty acids or unsaponifiable matters the above methods require certain corrections; thus, the value $E = \frac{w}{n}$, found as above for the saponification equivalent, does not represent the true equivalent of the glyceride or other compound ether present along with other matters, but only the *mean equivalent of all the substances present* (infinity in the case of non-saponifiable substances). If, as is usually the case, the unsaponifiable matters present are insoluble in water, the weight of substances obtained on saponifying and weighing the liberated fatty acids, is too great by the amount of unsaponifiable substances present; and also by the

* *Benedikt, Monatshefte für Chemie*, 11, p. 71.

weight of fatty acids originally present in the free state: these are determined as described on pp. 116, 119.

Suppose that a weight of substance, W , when saponified with alkali, neutralises n_1 c.c. of normal fluid; and, as the result of a previous titration before saponifying, suppose that n_2 c.c. represent the normal alkali equivalent to the free fatty acids present in the same weight, W , and that w_1 milligrammes is the weight of these fatty acids. Further, let the weight of unsaponifiable matter contained in W of substance be w_2 milligrammes. Then the saponifiable compound ethers, glycerides, &c., present weigh $W - w_1 - w_2$ milligrammes; and the normal alkali neutralised by them on saponification is $n_1 - n_2$; hence the corrected saponification equivalent of the saponifiable matters free from impurities is

$$E' = \frac{W - w_1 - w_2}{n_1 - n_2},$$

and the potash permillage for these saponifiable matters free from impurities is

$$K' = \frac{n_1 - n_2}{W - w_1 - w_2} \times 56,100.$$

Sometimes it happens that during saponification products are formed that are insoluble in water and consequently swim up to the top when the resulting soaps are decomposed by a mineral acid so as to separate the fatty acids formed by saponification; *e.g.*, in the case of cetacean oils, waxes, &c., where alcohols of high molecular weight, and not glycerol, are set free; in such cases, in order to obtain a correct valuation of the fatty acids, the quantity of such alcohols, &c., mixed with them must be determined.* This is usually conveniently effected by evaporating to dryness the alcoholic solution obtained when the weighed impure acids have been titrated (p. 164), and dissolving away the alcohols, &c., with ether or benzoline, so as to separate them from the soap; the filtered solution thus obtained is then evaporated, and the residue weighed and subtracted from the weight of crude fatty acids.

The equivalent weight of the fatty acids then will be

$$E = \frac{w - w'}{n}$$

where w is the weight in milligrammes of crude fatty acids, w' that of alcohols, &c., admixed therewith, and n the number of c.c. of normal alkali neutralised.

* Owing to saponification changes occurring on keeping or during refining, it sometimes happens that considerable quantities of cetylic, dodecylic, &c., alcohols are contained *as such* in sperm oil, spermaceti, beeswax, and similar substances, in addition to those existing as compound ethers; as much as 40 to 50 per cent. has been found in extreme cases (Allen and Thomson).

Mean Equivalent of Fatty Acids Contained in Soap.—

In the examination of soap it is often required to determine the mean equivalent of the fatty acids present therein as potash or soda soap; methods of calculation analogous to the above are then used. In such cases the analytical methods used (Chap. XXI.) usually give the following data:—

Percentage of total alkali present (reckoned say as Na_2O),	=	a
" alkali not combined with fatty acids (so called "free alkali"),	=	b
" free fatty acids formed on decomposition of the soap by mineral acids (together with unsaponified fat and neutral bodies, &c.),	=	c
" unsaponified fat and neutral bodies, &c.,	=	d

Then 100 parts of material contain $a - b$ per cent. of alkali (reckoned as Na_2O) combined as soap with fatty acids, which soap again yields, on decomposition by a stronger acid, $c - d$ per cent. of fatty acids free from unsaponified fat and neutral bodies. The mean equivalent E of these fatty acids is then given by the proportion (31 being the equivalent of sodium oxide, Na_2O)

$$a - b : 31 :: c - d : E,$$

whence

$$E = \frac{c - d}{a - b} \times 31.$$

The fatty acids yielded by cokernut oil have an average equivalent weight of not far from 200, whilst those from tallow, palm oil, and olive oil have much higher values, near 275, still higher equivalent weights being possessed by the mixtures of acids yielded by castor oil (near 300) and oil of ben and rape oil (near 330°); cerotic and melissic acids from beeswax have equivalent weights of 410 and 452 respectively. Hence in many cases the numerical value of the equivalent weight of the fatty acids affords a useful indication as to the nature of the oils, &c., used in manufacturing the soap examined.

Calculation of Composition of a Mixture of Two Fatty Acids from their Mean Neutralisation Number.—In certain cases where a substance is examined known to be a mixture of two different fatty acids, the relative amounts of the two constituents can be at least approximately calculated from their mean neutralisation number. Thus in the case of a mixture of *palmitic acid* (molecular weight = 256) and *stearic acid* (284), let the neutralisation number of the mixture be n ; the mean molecular weight of the mixture will accordingly be $\frac{56,100}{n}$ (p. 164). Hence the following table gives the relative proportions of the two acids:—

Mean Molecular Weight.	Percentage of	
	Palmitic Acid.	Stearic Acid.
256	100	0
258.8	90	10
261.6	80	20
264.4	70	30
267.2	60	40
270.0	50	50
272.8	40	60
275.6	30	70
278.4	20	80
281.2	10	90
284.0	0	100

The following formula gives the same result:—Let S be percentage of stearic acid, and M the mean molecular weight; then

$$S = (M - 256) \times \frac{100}{28}$$

$$= (M - 256) \times 3.5716.$$

In similar fashion the relative proportions of any other two fatty acids in a mixture thereof can be calculated.

REICHERT'S TEST.

Various natural oils and fats yield on saponification the alkali salts of mixtures of acids, some of which are readily volatile with the steam of water at ordinary pressure, and others practically non-volatile. Reichert* has based on this a useful method for the examination of butter as regards adulteration with other kinds of fatty matter (oleomargarine, &c.), these adulterants furnishing much smaller proportions of volatile acids. In practice, it is not convenient to continue the distillation until all the volatile acid present has passed over, so that a particular method of manipulation is employed, in order that an approximately constant fraction of the volatile acids may be distilled off. For this purpose 2.5 grammes of the fat to be examined are heated with 25 c.c. of approximately seminormal alcoholic potash in a flask with reflux condenser, until saponification is complete; the alcohol is evaporated off (by transferring to an evaporating dish), and the residue dissolved in water, slightly acidulated with dilute sulphuric acid, and made up to 70 c.c., of which 50 are distilled off.† The distillate is filtered if solid acids insoluble in

* *Zeits. Anal. Chem.*, 18, p. 68.

† To avoid bumping, pumice stone with platinum wire coiled round should be placed in the distilling vessel.

cold water have passed over, and titrated with decinormal alkali, using phenolphthalein as indicator. Working in this way about $\frac{1}{2}$ of the total volatile acids, soluble in water, of genuine butter are obtained in the distillate.

The following table is given by A. H. Allen,* representing the collected results obtained by himself and other analysts employing this method of manipulating:—

Substance of which 2.5 grammes are used.	C.c. of Decinormal Alkali neutralised by Distillate (filtered when necessary).	Percentage of KOH neutralised.
MILK FATS—		
Cow's butter,	12.5 to 15.2	2.80 to 3.41
Ewe's butter,	13.7	3.07
Goat's butter,	13.6	3.05
Porpoise's butter,	11.3	2.51
ANIMAL & VEGETABLE OILS & FATS—		
Cokernut oil, †	3.5 to 3.7	0.78 to 0.83
Palmnut oil,	2.4	0.54
Palm oil,	0.8	0.18
Cacao butter,	1.6	0.36
Butterine and oleomargarine,	0.2 to 1.6	0.04 to 0.36
Whale oil,	3.7 to 12.5	0.83 to 2.50
Porpoise oil,	11 to 12	2.47 to 2.69
Sperm oil,	1.3	0.29
Bottlenose oil,	1.4	0.31
Menhaden oil,	1.2	0.27
Cod liver oil,	1.1 to 2.1	0.24 to 0.47
Sesamé oil,	2.2	0.48
Cotton seed oil,	0.3	0.07
Castor oil,	1.4	0.31

Meissl ‡ slightly modifies Reichert's test by using 5 grammes of fat instead of 2.5; the evaporated alcoholic soap is dissolved in 100 c.c. of water, and acidified with 40 c.c. of 10 per cent. sulphuric acid solution. 110 c.c. are distilled off, of which 100 is filtered through a dry filter and titrated, the decinormal alkali consumed being increased by one tenth, to allow for the 10 c.c. not used. The results are usually somewhere about double those obtained by Reichert's method of manipulation—i.e., are much the same per given weight of butter, taking into account the doubled weight of fatty matter used.

The following table is given by Schädler, representing the number of c.c. of decinormal alkali neutralised by the volatile

* *Commercial Organic Analysis*, vol. ii., p. 46.

† By adding more water and continuing the distillation, a large amount of solid fatty acid, mostly insoluble in water (chiefly lauric acid), can be distilled over in the case of cokernut oil.

‡ *Dingler's Poly. Journ.*, 233, p. 229.

acids distilled off when the Reichert-Meissl test is employed (5 grammes of material used):—

Name of Oil, &c.	C.c. of Decinormal Alkali.
Arachis,	0·4
Almond,	0·55
Cotton seed,	0·95
Cokernut,	7·3
Cod liver,	0·4
Castor,	4·0
Colza, crude,	0·90
„ refined,	0·58
Lard,	1·10
Linseed,	0·95
Nut (walnut),	0·92
Olive,	1·5
Palm,	0·5
„ kernel,	3·4
Poppy,	0·6
Seal oil,	2·6
Sesame,	1·2
Sunflower,	0·5
Tallow (ox),	1·0
„ (sheep),	1·2

Several other modifications of Reichert's mode of manipulating have been proposed by different chemists with the object of obtaining greater accuracy; thus Wollny* employs special precautions to avoid the presence of carbon dioxide in the distillate and eliminate its disturbing effect, and prescribes that the distillation (using 5 grammes of butter fat) should always last the same time, 30 minutes. Similarly, Leffmann and Beam use a solution of caustic soda in glycerol instead of alcohol, to diminish possible formation of volatile acids by the action of the alkali on the alcohol. Methylic alcohol is used by others for the same purpose. Admitting that pure butter fat gives a Reichert-Wollny number = 27, and that the corresponding number for average margarine is 2, then a sample of butter fat mixed with margarine and giving the number R will contain x per cent. of margarine, where

$$x = 100 \times \frac{27 - R}{25} = 4(27 - R).$$

The term "Reichert number" (*Reichert'sche Zahl*) is frequently given to the figure expressing the number of c.c. of decinormal alkali neutralised by the distillate obtained when operating in the way prescribed by Reichert, using 2·5 grammes of substance; and similarly the terms "Reichert-Meissl number" and "Reichert-Wollny number" (*Reichert-Meissl'sche Zahl* and *Reichert-Wollny'sche Zahl*) to the corresponding figures obtained when Meissl's or Wollny's modification of Reichert's process is used (employing

* *The Analyst*, 1887, p. 203, *et seq.*; from the *Milch Zeitung*, 1887, Nos. 32-35.

5 grammes of substance). The two latter numbers are each approximately double the first on account of the larger weight of material. To avoid confusion between these different values, it is convenient to translate them into terms of caustic potash (KOH = 56.1) neutralised by the volatile acid obtained from 1,000 parts of substance, to which value the term "*volatile acid number*" (or volatile acid potash permillage) may be conveniently applied; this translation is effected by means of the formulæ—

$$\begin{aligned} \text{Volatile acid number} &= \text{Reichert number} \quad \cdot \quad \cdot \quad \times 2.244 \\ \text{,,} \quad \text{,,} &= \text{Reichert-Meissl number} \quad \times 1.122 \\ \text{,,} \quad \text{,,} &= \text{Reichert-Wollny number} \quad \times 1.122 \end{aligned}$$

The volatile acids thus indicated are usually considerably below the total amount actually present; according to Allen, the deficiency is somewhere about one-fifth in the case of butter fat, and presumably in about the same proportion in other cases. When a nearer approximation is requisite to the total volatile acid present, water must be added to the residue in the retort and distillation recommenced, and so on as long as acid vapours pass over; or more conveniently, steam may be blown through the liquid from a separate boiling vessel.

BROMINE AND IODINE ABSORPTION.

Organic compounds containing a group of the character - CR = CS - tend to combine with two atoms of a given halogen such as bromine or iodine, forming a group of formula - CRBr - CSBr -, or - CRI - CSI -. Accordingly, organic acids thus constituted are capable of uniting directly with halogens to an extent dependent on the number of times that such "doubly linked" carbon groups occur; thus oleic and ricinoleic acids, which contain one such doubly linked pair of carbon atoms, unite with Br₂.

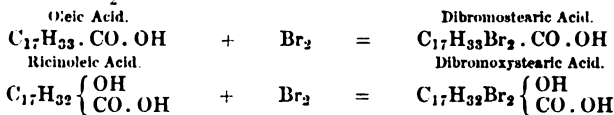

Similarly, linolic acid combines with Br₄, as it contains *two** such doubly-linked pairs of carbon atoms.

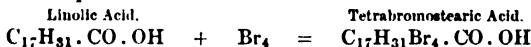

Whilst linolenic acid, containing 3 such pairs,† unites with Br₆—

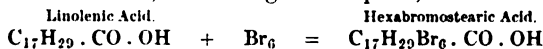

* Or possibly a trebly-linked pair of carbon atoms, forming the group - C - C -, which, by uniting with Br₄, produces a group of formula - CBr₂ - CBr₂ -.

† Or possibly one trebly-linked pair, and one doubly-linked pair.

In certain cases, the bromine addition products thus formed are crystallisable, and thus afford the means of separating organic acids from one another (pp. 27, 35, 36); in any case, by determining the quantity of halogen fixed by a given acid or mixture of acids, useful information is often obtained as to the nature of the fatty acids present; for instance, if a mixture of stearic and oleic acids took up, say, 45 per cent. of its weight of iodine, since stearic acid takes up no iodine, and oleic acid 90 per cent. of its weight, it would result that the mixture contained the two acids in approximately equal quantities. Methods for the determination of the amount of oleic acid in mixtures of this kind are of considerable practical utility; in particular, the author has found the method useful in determining the proportion of oleic acid contained in the "stearine" used for candle making.

Precisely the same remarks also apply to the glycerides of the fatty acids, with the sole difference that their combination with halogens generally takes place more slowly than is the case with the fatty acids contained, or with the parent hydrocarbons of these fatty acids.

As far back as 1857, attempts to utilise the reaction with bromine for the practical discrimination of fats were made by Cailletet, and subsequently by A. H. Allen, Mills, and others; but although in certain cases useful results are thus obtainable, in practice it is found that the use of iodine is preferable, more especially when applied in the modified form proposed by Hübl (*vide infra*), where mercuric chloride and iodine are dissolved in alcohol, and the compound solution allowed to act on the fat.

In this case, the product formed is not simply an iodine addition product; the mercuric chloride appears to be more or less transformed into mercuric iodide, with formation of chloride of iodine, so that the addition product contains both chlorine and iodine; thus oleic acid, $C_{18}H_{34}O_2$, treated with this reagent becomes mostly converted into chloriodostearic acid, $C_{18}H_{34}ClIO_2$, and similarly in other cases. The chlorine thus added on is in practice never reckoned as such, but as its equivalent in iodine; so that 282 parts of oleic acid, when treated with Hübl's reagent, are regarded as combining with $2 \times 127 = 256$ parts of iodine, although usually the compound produced is formed by taking up 127 parts of iodine + 35.5 parts of chlorine.

Bromine Process.—The bromine absorption process, as improved by Mills and Snodgrass,* and Mills and Akitt,† consists in dissolving bromine in carbon disulphide, or preferably carbon tetrachloride, to a solution containing 0.6 to 0.7 per cent. of bromine, and adding this to a solution of a weighed quantity of oil in the same solvent, until no more combination takes place. In the earlier experiments with carbon disulphide a slight excess of bromine was added, and the colour, after standing 15 minutes,

* *Journ. Soc. Chem. Industry*, 1883, p. 435. † *Ibid.*, 1884, p. 366.

Substance.	Percentage of Bromine absorbed.	Specific Gravity at 11°-12°.	Melting Point.	Remarks.
Almond oil, . . .	26·27	·9168	...	Expressed from bitter almonds.
" . . .	53·74	·9154	...	Expressed from sweet almonds; yellower.
Beeswax, . . .	0·54	...	63·9	English, a few months old; very yellow.
" . . .	0	...	63·2	Scotch, 8 years old; pale.
" . . .	0	...	62·9	" 2 " yellow.
" . . .	0	...	63·3	" 1 " "
Ben oil, . . .	52·95	·9198	...	Much solid fat.
" . . .	50·89	·9161	...	No solid fat.
Carnauba wax, . . .	33·50	...	84·1	...
Cod liver oil, . . .	83·12	·9269	...	Scotch, 7 years old; rancid; clear portion used; 1 hour's absorption.
" . . .	84·03	·9292	...	Norwegian, refined, 2 years old.
" . . .	82·94	·9257	...	Japanese, 2 years old.
" . . .	81·61	·9277	...	Scotch, 2 years old.
" . . .	86·69	·9281	...	Crude, from liver refuse; a few months old.
" . . .	83·01	·9318	...	Norwegian, 1 year old.
" . . .	82·07	·9278	...	Scotch
Croton oil, . . .	46·66	·9441	...	20 hours' absorption.
Eucalyptus oil, . . .	94·09	·8691
Horse fat, . . .	35·67	Pasty; well mixed.
Japan wax, . . .	2·33	...	50·5	...
" (another sample),	1·53	...	50·8	...
Java nut oil, . . .	30·24
Ling liver oil, . . .	82·44	·9295	...	2 years old; 1 hour's absorption.
Maize germ oil, . . .	74·42	·9262	...	4 years old.
Mustard seed oil, . . .	46·15	·9152	...	East Indian.
Myrtle wax, . . .	6·34	...	44·3	...
Neat's foot oil, . . .	38·33	·9147	...	Thick.
Niger seed oil, . . .	35·11	·9244
Olive oil, . . .	59·34	·9266	...	Thick brown; "best sulphocarbon."
" . . .	60·61	·9382	...	Thinner greener; "low quality sulphocarbon."
Palm oil, . . .	35·44	Crude old Calabar.
" . . .	34·96	" Lagos.
Peach kernel oil, . . .	25·40	·9175
Poppy oil, . . .	56·54	·9244	...	Turbid; filtered.
Resin (common), . . .	112·70	Light colour.
Seal oil, . . .	57·34	·9241	...	Pale; 1 hour's absorption.
" . . .	59·92	·9216	...	Dark.
" . . .	47·35	·9250
Sesamé oil, . . .	47·35	·9250
Shark liver oil, . . .	84·36	·9293	...	A few months old; 1 hour's absorption.
Sunflower oil, . . .	54·32	·9391	...	Colourless; about 16 years old.
Whale oil, . . .	30·92	·9199	...	Norwegian white whale; very thick.
" . . .	48·69	·8780	...	Bottlenose whale.

compared with that of a known amount of bromine dissolved in carbon disulphide, so as to obtain a colorimetric valuation of the excess; or the excess of bromine was estimated by adding potassium iodide and titrating with thiosulphate. In the later experiments with carbon tetrachloride, about 0.1 gramme of oil was dissolved in 50 c.c. of tetrachloride, an excess of bromine solution added, and after 15 minutes the excess back-titrated, either by the coloration method,* by iodide and thiosulphate, or by a standard solution of β naphthol in carbon tetrachloride.

The table on p. 178 gives the results of a number of determinations thus made.

Iodine Process—Hübl's Test.—The iodine absorption process of Baron Hübl is thus worked.† An alcoholic solution of mercuric chloride and iodine in pure 95 per cent. alcohol is prepared by dissolving 50 grms. iodine in one litre of spirit, and 60 grms. corrosive sublimate in another litre, filtering the latter if necessary, and mixing the two solutions; preferably they are kept apart and only mixed a day or two before use;‡ the compound solution rapidly loses strength (as regards free iodine) if fusel oils are present in the alcohol, methylated spirit being wholly inadmissible; in any case the liquid should be allowed to stand at least a day before use, so that any small quantity of iodine-consuming impurities may be eliminated as far as possible; the actual iodine strength must be determined from time to time to allow for depreciation. From .2 to .3 grm. of drying oils, .3 to .4 of non-drying oils, or .8 to 1.0 grm. of solid fat, is dissolved in 10 c.c. of pure chloroform (*i.e.*, containing no iodine-destroying impurity), and to the solution 30 or 40 c.c. of iodine solution added, more being added if on standing awhile the brown colour lightens materially; enough solution must be added in all to give a large excess of free iodine when the action is complete after several hours standing. The excess of iodine is titrated by adding some aqueous potassium iodide solution (10–15 c.c. of 10 per cent. solution, along with 150 c.c. of water), and then standard sodium thiosulphate (about 24 grms. to litre, standardised by means of pure sublimed iodine, or by pure potassium dichromate) until the blue colour with starch paste is just decolorised, the starch being only added when nearly all the free

* When the oil is yellow, as with certain fish oils, the redness due to excess of bromine is best examined by viewing through a solution of potassium chromate.

† *Dingler's Polytech. Journal*, 1884, pp. 253, 281; in abstract, *Journ. Soc. Chem. Ind.*, 1884, p. 641.

‡ According to Saytzeff, *mercuric bromide* is preferable to corrosive sublimate, the solution being more stable. Some chemists only mix the two solutions at the moment they are wanted; but according to the author's experience, this considerably increases the chances of error. If mercuric chloride be not added at all (*e.g.*, if a solution of iodine in carbon tetrachloride be used), the quantity of iodine absorbed is in some cases largely diminished as compared with that taken up with Hübl's fluid.

iodine is destroyed. As the excess of iodine is dissolved partly in the aqueous liquor and partly in the chloroform, the whole must be well agitated. Unless a considerable excess of free iodine is present, and the whole allowed to stand for several hours, defective results are apt to be obtained with glycerides, as the assimilation of iodine with these bodies is not always rapid; free fatty acids combine with iodine more quickly. A good rule is to use an excess of iodine approximately equal to the amount absorbed,* and to allow the whole to stand until the next day before titration of the uncombined iodine; one or more blank experiments being simultaneously arranged to allow for possible depreciation in strength of the iodine solution during the period; this lengthened time is more especially requisite in the case of oils absorbing large amounts of iodine. Thus the following figures illustrate this point (Thomson and Ballantyne):—

Time of Absorption.	Iodine Number found.	
	Seal Oil.	Linseed Oil.
2 hours.	136·6	175·5
4 "	140·8	179·7
6 "	145·1	184·1
8 "	145·8	187·7
18 "	145·8	187·7

Similar figures have been published by various other observers in the case of glycerides absorbing large proportions of iodine, whereas, with free fatty acids and glycerides absorbing but little iodine, the reaction is ordinarily found to be practically complete in 2 hours.

When the iodine absorption of free fatty acids is to be determined, it is unnecessary to dissolve in chloroform; the alcoholic mercury-iodine solution may be added directly to the weighed fatty acids, previously thinned a little by warming with a small quantity of pure alcohol. The following table represents the amounts of iodine theoretically taken up by 100 parts of the several acids and their respective triglycerides:—

Name.	Formula.	Iodine Absorption.	
		Acid.	Glyceride.
Hypogæic acid, . . .	$C_{16}H_{30}O_2$	100·00	95·25
Oleic acid, . . .	$C_{18}H_{34}O_2$	90·07	86·20
Erucic acid, . . .	$C_{22}H_{42}O_2$	75·15	72·43
Ricinoleic acid, . . .	$C_{18}H_{34}O_3$	85·24	81·76
Linolic acid, . . .	$C_{18}H_{32}O_2$	181·43	173·57
Linolenic acid, . . .	$C_{18}H_{30}O_2$	274·10	262·15

* In the case of oils absorbing large quantities of iodine, a still greater excess is preferable, about twice the quantity absorbed. In all cases the quantity of iodine used for the blank experiment should be approximately equal to the excess employed.

	Name of Oil.	Percentage of Iodine absorbed.	Fatty Acids.		Caustic Potash, KOH, requisite to saponify 1,000 parts of Oil.	Solution of Oil in an Equal Amount of Glacial Acetic Acid (sp. gr. 1.056) becomes turbid at
			Fuse at	Solidify at		
			Degrees C.	Degrees C.		Degrees C.
I. DRYING OILS.	Linseed oil,	156-160, mean = 158	17.0	13.3	194.3	...
II. DRYING OILS.	Hempseed oil,	143	19.0	15.0	193.1	...
	Nut oil,	142-144,	20.0	16.0	196.0	...
	Poppy oil,	135-137,	20.5	16.5	194.6	...
	Pumpkin seed oil,	121	28.0	24.5	189.5	108
III. MODERATELY DRYING OILS.	Sesamé oil,	105-108,	26.0	22.3	190.0	107
	Cotton seed oil,	105-108,	27.7	30.5	195.0	110
	Arachis oil,	101-105,	27.7	23.8	191.3	112
	Rape seed oil,	97-105,	20.1	12.2	177.0	Insoluble.
IV. NON DRYING OILS.	Apricot kernel oil,	99-102,	4.5	0	192.9	114
	Almond oil,	97.5-98.0,	14.0	5.0	195.4	110
	Castor oil,	84.0-84.7,	13.0	3.0	181.0	Soluble in the cold.
	Olive oil,	81.6-84.5,	26.0	21.2	191.7	85-111
	Olive kernel oil,	81.8	188.5	Soluble in the cold.
V.	Bone oil,	66.0-70.0,	30.0	28.0
	Hog's lard,	57.6 60.0,	195.9	...
	Artificial butter,	55.3	42.0	39.8
VI.	Palm oil,	51.5	47.8	42.7	202.2	23
	Laurel oil,	49.0	27.0	22.0	...	26.5
	Tallow,	40.0	45.0	43.0	196.5	95
	Fat from suet,	36.0	41.8	40.0	170.0	...
	Cacao butter,	34.0	52.0	51.0	...	105
	Nutmeg butter,	31.0	42.5	40.0	...	27
	Butter fat,	26.0-35.1,	38.0	35.8	227.0	...
VII.	Cokernut oil,	8.9	24.6	20.4	261.3	40
	Japanese wax,	4.2	222.2	...

In actual practice, Hübl found that pure oleic acid took up 89.8-90.5 per cent. of iodine, and obtained the values quoted on p. 181 on examining a variety of fats and oils by different processes simultaneously, the substances being divided into 7 classes, according to the magnitude of the iodine absorption.

Schädler gives the following values as those most generally found pertaining to various oils and fats, &c. :—

Name of Oil or Fat.	Iodine Number of	
	Oil, &c.	Fatty Acids
Almond,	82-83	87-90
Apricot kernel,	100-102	...
Arachis,	94-96	96-97
Butter,	28-32	...
Bone,	66-68	56-57
Cacao butter,	34	...
Castor,	93-94	...
Charlock,	96-97	...
Colza,	100-101	97-99
Cokernut,	9-9.5	8.5-9.0
Cotton seed,	106-107	112-115
Curcas,	127	...
Cod liver { medicinal,	128-130	...
{ brown,	135-140	...
Hemp,	143-144	122-124
Hedge radish,	105	...
Japanese wax,	4.2	...
Linseed,	177-178	155
Lallemantia (Gundscht),	162	167
Lard,	59-60	...
Maize,	119.5	125
Nut (walnut),	142-143	...
Olive (salad),	82-83	87-88
Olive kernel,	82	...
Palm,	51.5	...
Palm kernel,	13.5-14	12
Poppy,	134-135	...
Pumpkin seed,	121	...
Rape seed,	98-100	97-99
Suet (ox tallow, beef tallow),	38-40	26-30
Seal,	125-130	...
Sesamé,	103-105	110-111
Sunflower,	129	133-134
Sperm oil,	88	...
Spermaceti,	108	...
Tacamahac,	63	...
Tallow (sheep),	43-44	...
Ungnadia,	81.5-82	86-87
Wool grease,	36	...

The following tables represent the collected results published

by numerous observers,* during the last few years, as the amounts of iodine taken up by 100 parts of different oils and fats :—

VEGETABLE OILS.

Name.	Minimum.	Maximum.	Average.
Fresh linseed oil, . . .	170	181	175
Commercial oil, . . .	148	181	170
Lallemantia oil,	162
Hemp seed oil, . . .	142	158	150
Nut oil, . . .	143	152	146
Poppy seed oil, . . .	134	142	138
Sunflower seed oil, . . .	122	133	128
Curcas oil,	127
Pumpkin seed oil,	121
Maize oil,	120
Cotton seed oil, . . .	102	111	108
Sesamé oil, . . .	103	112	108
Hedge radish oil,	105
Rape seed oil, . . .	99	105	101
Apricot kernel oil, . . .	99	102	100
Almond oil, . . .	96	102	98
Arachis oil, . . .	87·3	103	96
Mustard oil,	96
Castor oil, . . .	83	85	84·5
Olive oil, . . .	81	84·5	82·8
Olive kernel oil,	81·8

ANIMAL OILS.

Name.	Minimum.	Maximum.	Average.
Cod liver oil, . . .	126	153	140
Seal oil, . . .	127	128	127
Japanese cod liver oil,	120
Bottlenose oil,	99·5
Porpoise oil,	78·8
Neat's foot oil,	70·3
Bone oil, . . .	66	70	68
Porpoise oil oleine, . . .	30·9	49·6	40·2
Bottlenose oleine,	32·8

* Hübl, Moore, Dieterich, Wilson, Erban, Herz, Spüller, Horn, Richter, Kremel, Beringer, and Benedikt; collated by Benedikt.—*Analyse der Fette und Wachsarten*, 2nd edition, pp. 298 and 317.

SOLID FATS.

Name.	Minimum.	Maximum.	Average.
Cotton seed stearine,	89.6
Goose grease,	71.5
Hog's lard,	56	63	59
Macassar oil,	53
Bone grease,	46.3	55.5	52
Palm butter,	50.3	53.9	51
Oleomargarine,	47.5	55.3	50
Laurel butter,	49
Ox tallow,	40	44	42
Sheep's tallow,	32.7	46.2	42
Wool grease,	36
Cacao butter,	34	37.7	36
Nutmeg butter,	31
Butter fat,	19.5	38.0	30
Palm kernel butter,	10.3	17.5	14
Coker butter,	7.9	9.4	9
Japanese wax,	4.2

Slightly higher values still for some of the drying oils have been recently deduced by Holde in the course of an investigation on the sources of error in the Hübl test,* the cause being assigned to more complete saturation with iodine through use of a larger excess of solution. Thus—

Linseed oil,	179 to 180
Hempseed oil,	175
Poppy seed oil,	139 to 143
Sesamé oil,	106 to 109
Cotton seed oil,	110 to 115
Common rape oil,	100 to 108
Refined rape oil,	100 to 107

The following values have also been recorded for the mixed fatty acids from various commercial oils:—

	Morawski and Demski.	Williams.
Linseed oil acids,	155.2 to 155.9	178.5
Hempseed oil acids,	122.2 to 125.2	...
Cotton seed oil acids,	110.9 to 111.2	115.7
Sesamé oil acids,	108.9 to 111.4	...
Rape seed oil acids,	96.3 to 99.02	105.6
Arachis oil acids,	95.5 to 96.9	...
Castor oil acids,	86.6 to 88.3	93.9
Olive oil acids,	86.1	90.2

Owing to the tendency towards absorption of oxygen exhibited by drying oils and the fatty acids obtained from them, there is

* *Journ. Soc. Chem. Ind.*, 1891, p. 954; from *Mitth. Königl. tech. Versuchs*, Berlin, 1891, 9, p. 81.

always a liability to obtain somewhat different results with free fatty acids as compared with the original oils from which they were obtained, owing to partial oxidation during isolation and drying. As a rule, absorption of oxygen seems to diminish the iodine absorption as might, *a priori*, be expected.

Neglecting this alteration, the amounts of iodine absorbed by an oil, &c., and by the fatty acids thence obtainable, necessarily stand to one another in the inverse ratio of their respective mean equivalent weights; for if E be the saponification equivalent of an oil, and F the mean equivalent weight of the fatty acids thence obtainable, quantities of oil and free acid in the respective proportion of E to F will combine with the same quantity of iodine; so that the iodine taken up by 100 parts of oil will be $\frac{F}{E}$ times that taken up by 100 parts of fatty acids; i.e., if I be the iodine number of the oil and I' that of the fatty acids—

$$I = \frac{F}{E} I'$$

and

$$I' = \frac{E}{F} I$$

If the oil, &c., consist wholly of triglycerides, $E = F + 12.67$ (p. 165); whence

$$\begin{aligned} I' &= \frac{F + 12.67}{F} I \\ &= I \left(1 + \frac{12.67}{F} \right). \end{aligned}$$

Hence for fatty acids of molecular weight between 250 and 330, the iodine number of the fatty acids is between 5.1 and 3.8 per cent. greater than that of the original oil; so that for the great majority of natural oils and fats, the iodine number of the free fatty acids *exceeds* that of the oil by an amount sensibly close to 4.5 per cent. of the latter value.

Obviously, in some of the cases above tabulated, a notable difference must have subsisted between the samples used for the determination of the iodine number of a given oil, and of that of the fatty acids derived from the same kind of oil, since the latter values are, in some instances, *less* than the former ones instead of exceeding them by about 4.5 per cent. of their value.

The theoretical amount of iodine corresponding with 100 parts of pure olein is 86.2 parts. From the numbers above tabulated, it is obvious that many of the fluid vegetable oils, usually regarded as non-drying (arachis, almond, apricot kernel, &c.), contain some small amount of glycerides of the linolic or drying class, since their iodine absorptions exceed 86.2; *a fortiori*, with oils of the intermediate class exhibiting a slight amount of

drying quality (cotton seed, sesamé, sunflower, &c), a larger iodine absorption is observed, corresponding with a still more marked proportion of drying oil constituents.

ACETYLATION TEST—BENEDIKT AND ULZER'S TEST.

When organic substances containing alcoholiform hydroxyl are heated in contact with acetic anhydride, an action takes place which may be regarded as the converse of saponification or hydrolysis; the hydroxylated body, X.OH, acts upon the anhydride in accordance with the equation—

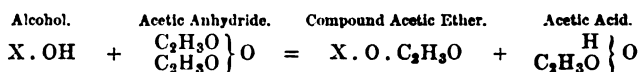

giving rise to a compound ether. Polyhydroxylated bodies behave in the same way, one acetyl group being taken up for each alcoholiform hydroxyl group present; thus glycerol treated with acetic anhydride becomes transformed into triacetin in accordance with the equation—

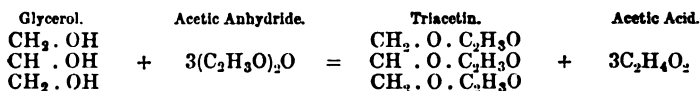

On this reaction is based a method for the analytical examination of commercial glycerol (Chap. XXII.) Benedikt and Ulzer have also attempted to utilise this reaction to distinguish hydroxylated organic acids (like oxystearic and ricinoleic acids) from non-hydroxylated acids, such as stearic and palmitic acids. Their method is based on the assumption that acetic anhydride exerts no action on the hydroxyl of the CO.OH group of an organic acid, but does act, in accordance with the above equation, on any alcoholiform hydroxyl contained therein; so that if, for example, stearic acid be treated with acetic anhydride, and the product heated with water so as to decompose excess of acetic anhydride, simply unchanged stearic acid results;* whereas, if oxystearic acid be similarly treated, *acetyl oxystearic acid* is produced, thus—

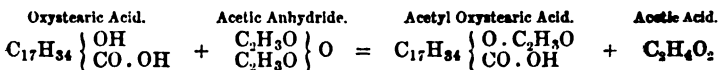

The acetylated acids thus formed are stated to be moderately stable, not being appreciably hydrolysed by the action of the hot

* This assumption is entirely at variance with the results obtained by Lewkowitsch; *vide infra*.

water requisite to decompose the excess of acetic anhydride present. Accordingly, if after thus removing excess of acetic anhydride, the resulting acetyl acid be titrated with standard alkali, one equivalent of alkali will be directly neutralised; whilst if it be heated with excess of alcoholic alkali so as to saponify it, reproducing oxystearic acid and acetic acid, thus—

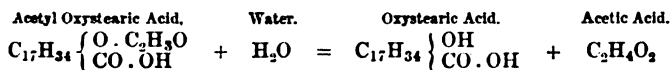

two equivalents will be neutralised in all, the second by the acetic acid formed. In the case of a mixture of acids containing hydroxylated and non-hydroxylated constituents, the proportion of the latter can be estimated by determining the extra amount of potash neutralised on saponification, as compared with that neutralised directly. The term "acetyl number" (*acetylzahl*), is used to indicate the weight of potash (KOH = 56.1) neutralised by the acetic acid formed from 1,000 parts of mixed acetylated product.*

The acetylation process is carried out thus:—The free fatty acids formed by saponifying a given sample of oil and decomposing the soap by a mineral acid, are boiled for two hours with an equal volume of acetic anhydride in a flask with inverted condenser attached; the mass is then boiled for half an hour with about 20 parts of water; the acetic acid solution formed is siphoned off, and the treatment with boiling water repeated three times, so that finally the water is free from acidity after boiling for half an hour. The acetylated product is then filtered through a dry filter paper to remove water, and a weighed quantity dissolved in pure alcohol. Standard alcoholic potash is added to neutrality, and the amount neutralised noted; more than as much again is then added, and the whole heated to boiling, whereby the acetyl derivative is saponified; the unneutralised alkali is then back-titrated. Thus in the case of the fatty acids from a sample of castor oil the following figures were obtained: †—3.379 grammes of acetylated product neutralised 17.2 c.c. of seminormal potash, whence the "acetyl acid number" is 142.8. After

* Benedikt and Ulzer term the potash directly neutralised by 1,000 parts of mixed acetylated product, the "acetyl acid number" (*acetylsäurezahl*), and the total neutralised on saponification (sum of *acetylzahl* and *acetylsäurezahl*) "the acetyl saponification number" (*acetylverseifungszahl*). Thus the theoretical values for acetyl oxyoleic (ricinoleic) acid are—

Acetyl number,	165.0
Acetyl acid number,	165.0
Acetyl saponification number,	330.0

† Benedikt, *Analyse der Fette und Wachsarten*, 2nd edition, 1892, p. 114.

addition of 32.8 c.c. more potash and boiling, 14.3 c.c. were found to be unneutralised, whence 18.5 c.c. represent the acetic acid formed on saponification, giving the "acetyl number" 153.6, and the "acetyl saponification number" $142.8 + 153.6 = 296.4$. Since the acetyl number exceeded the acetyl acid number, it would hence result that some amount of a *dihydroxylated* acid was present, especially as the mixed acids of castor oil contain a small quantity of stearic (non-hydroxylated) acid to begin with (*vide infra*).

Operating in this way, Benedikt and Ulzer found the following values for various oils:— *

Oil Used.	"Neutralisation Number" of Fatty Acids before Acetylation.	Acetyl Acid Number.	Acetyl Number.	Acetyl Saponification Number.
Arachis, . . .	198.8	193.3	3.4	196.7
Cotton seed, . . .	199.8	195.7	16.6	212.3
Croton, . . .	201.0	195.7	8.5	204.2
Hemp seed, . . .	199.4	196.8	7.5	204.3
Linseed, . . .	201.3	196.6	8.5	205.1
Almond, . . .	201.6	196.5	5.8	202.3
Poppy seed, . . .	200.6	194.1	13.1	207.2
Nut, . . .	204.8	198.0	7.6	205.6
Olive, . . .	197.1	197.3	4.7	202.0
Peach kernel, . . .	202.5	196.0	6.4	202.4
Castor, . . .	177.4	142.8	153.4	296.2
Rape, . . .	182.5	178.5	6.3	184.8
Sesamé, . . .	200.4	192.0	11.5	203.5
"Soluble castor oil,"	...	184.5	62.2	246.7

J. A. Wilson † found the following average values for castor, olive, and cotton seed oils:—

	Acetyl Acid Number.	Acetyl Number.	Acetyl Saponification Number.
Castor oil, . . .	136.7	155.0	291.7
Olive oil, . . .	170.0	36.0	206.0
Cotton seed oil, . . .	189.5	21.0	210.5

Obviously these figures do not agree very sharply with the preceding ones. If the results of the acetyl test could be regarded as perfectly trustworthy, these values would indicate the existence of more or less considerable amounts of hydroxy acids in all the samples examined, amounting, in the case of the cotton seed and sesamé oils examined by Benedikt and Ulzer, to 6–8 per cent. of the total acids present, and to much larger amounts in the

* *Monat-hefte f. Chemie*, 1887, S, p. 41.

† *Journ. Soc. Chem. Ind.*, 1892, p. 495.

case of the olive and cotton seed oils examined by Wilson. The figures, however, do not exhibit such concordance as to be unexceptionable; the effect of acetylating the hydroxylated constituents of a mixture of acids containing only a small proportion of hydroxylated acids would be to cause the neutralisation number of the acetylated fatty acids (the acetyl acid number) to be only slightly less than their neutralisation number before acetylation, whereas the observed differences are materially larger. Thus the neutralisation numbers of oleic, oxyoleic, and acetyl oxyoleic acids are respectively 198.9, 188.25, and 165.0; whence a mixture of 90 parts oleic acid and 10 parts oxyoleic acid would have the neutralisation number 197.9; and after acetylation would furnish a mixture of oleic and acetyl oxyoleic acids having the neutralisation number (acetyl acid number) 195.5, or only 2.4 less than the original mixture. Similarly a mixture of 95 parts oleic acid and 5 parts oxyoleic acid would have the neutralisation number 198.4 before acetylation, and 197.2 after, giving the difference 1.2. The actual differences deduced from the above figures obtained by Benedikt and Ulzer with oils other than castor oil, vary between -0.2 (olive oil) and $+8.4$ (sesamé oil), but in most cases amount to from 5 to 6; strongly suggesting that some cause is at work abnormally diminishing the "acetyl acid number" by some units, and in consequence giving an apparent "acetyl number" of some units in magnitude, the result of this cause, and not of the existence of hydroxy acids in the fatty acids examined. The same conclusion also results from the figures obtained with castor oil acids, as the supposition that a considerable percentage of dihydroxylated acids is present is manifestly untenable.

Lewkowitsch has made some observations that throw light on the probable cause of these discrepancies.* His results indicate that by the action of acetic anhydride in excess the higher acids of the acetic family (such as lauric, palmitic, and stearic acids, &c.) become more or less completely converted into the corresponding anhydrides.† When the products freed from the excess of acetic anhydride by the action of water are neutralised by alkali, a diminution in the apparent amount of free acid is noticed proportionate to the amount of fatty anhydrides present not decomposed by the water treatment; and when the neutralised substance is heated with excess of alcoholic alkali, and subsequently back-titrated, a quantity of alkali is neutralised proportionate to the fatty acid formed by the hydration of the

* *Proceedings of the Chemical Society*, 1890, pp. 72 and 91.

† Anschütz found [*Annalen d. Chem. Pharm.* (1884) 226, p. 6] that when acetic anhydride and benzoic acid were heated together in a sealed tube at 220° benzoic anhydride was produced; whilst the dibasic acids, succinic, camphoric, orthophthalic, and diphenic acids were largely transformed into their respective anhydrides by heating with acetic anhydride at 120° to 150°.

fatty acid present; so that an apparent "acetyl number" is obtained even when no alcoholiform hydroxyl whatever is present in the body examined. Thus he obtained the following figures with samples of capric, lauric, palmitic, oleic, stearic, and cerotic acids in a state of only approximate purity so far as chemical identity is concerned, but any rate free from any notable amount of hydroxy acids:—

Fatty Acid Used.	Neutralisation Number.		Acetyl Acid Number.	Acetyl Number.	Acetyl Saponification Number.
	Theoretical for pure fatty acid.	Found.			
Capric, . .	326·2	318·05	176·40	174·00	350·40
Lauric, . .	280·5	273·02	161·50	132·49	293·99
Palmitic, . .	219·1	213·4	143·53	82·60	222·13
Oleic, . . .	198·0	183·0	116·50	125·55	242·05
Stearic, . .	197·5	203·0	138·89	82·29	221·18
Cerotic, . .	136·8	128·4	73·87	68·23	142·10

From these figures it obviously results that but little reliance is to be placed on the result of the acetylation test for alcoholiform hydroxyl in fatty acids when based simply on the titration process above described. Better results, however, can be obtained by modifying the test in the way proposed by Lewkowitsch;* the acetylated product is saponified with alcoholic potash, the alcohol boiled off, and the residue distilled with dilute sulphuric acid, much as in Reichert's test (p. 173). Any acetic acid formed by hydrolysis of acetyl derivatives is thus distilled over, and may be titrated by means of standard alkali and phenolphthalein. In this way dioxystearic acid (from oleic acid by alkaline permanganate) was found to form the anhydride of diacetyloxystearic acid, $\left. \begin{matrix} C_{17}H_{34} (O \cdot C_2H_3O)_2 \cdot CO \\ C_{17}H_{34} (O \cdot C_2H_3O)_2 \cdot CO \end{matrix} \right\} O$, on treatment with acetic anhydride; from this acetic acid was obtained on saponification and distillation in quantity but little below the theoretical amount. A revision of the fatty acids obtainable from oils and fats, &c. (as regards the amount of hydroxylated constituents present), based on the acetyl test thus applied would be desirable, but as yet does not appear to have been made.

On the other hand, the acetylation test gives good results with bodies not of an acid character, containing alcoholiform hydroxyl, more especially in the case of the higher homologues of ethylic alcohol: thus in the examination of waxes and bodies generally that give rise to higher alcohols, the amount of hydroxylated substances present may be measured by conversion into com-

* *Journ. Soc. Chem. Ind.*, 1890, p. 842.

pound ethers by means of acetic anhydride, and determining the permillage of potash neutralised on saponifying the product. Thus pure cetylic alcohol, $C_{16}H_{33} \cdot OH$, furnishes an acetyl derivative, *cetyl acetate*, $C_{16}H_{33} \cdot O \cdot C_2H_3O$, of molecular weight 284—i.e., 284 milligrammes of cetyl acetate will furnish 60 milligrammes of acetic acid on saponification, neutralising 1 c.c. of normal potash solution containing 56.1 milligrammes of potash (KOH); whence the "acetyl number" of cetyl acetate is $\frac{56.1}{284} \times 1000 = 197.5$.

If a given sample of cetyl alcohol (known to be admixed with foreign matter not capable of forming acetyl derivatives) furnish an acetyl derivative of which the acetyl number is found to be 98, obviously about one half of the substance is cetylic alcohol. A more exact value is obtained by determining the quantity of foreign matter present, subtracting that from the weight of acetylated product, and reckoning the acetyl number on the difference as 1000, in a way similar to that adopted in the parallel case of the determination of the Kœttstorfer number of a saponifiable body after correction for unsaponifiable matters present (p. 171).

In the case of impure glycerol the acetylation test is employed in a similar way; 92 parts of pure glycerol would furnish $3 \times 60 = 180$ parts of acetic acid on saponification of the triacetin formed therefrom, capable of neutralising $3 \times 56.1 = 168.3$ parts of potash. If a given sample of impure glycerol were found to neutralise n parts of potash per 92 of substance, the percentage of glycerol present would be $\frac{n}{168.3} \times 100$. Or otherwise, 92 milligrammes of pure glycerol would furnish acid neutralising 3 c.c. of normal alkali solution; hence if a weight w milligrammes of impure glycerol furnish acid neutralising x c.c. the percentage

of glycerol would be $\frac{\frac{x}{3} \times 92}{w} \times 100 = \frac{x}{w} \times 3066.7$.

In the examination of the unsaponifiable matters left on treating oils and fats, &c., with alkalis (p. 121), the substance may conveniently be converted into acetyl derivative by treatment with acetic anhydride, boiled with water to decompose excess of anhydride, crystallised from alcohol, and examined as to the acetyl number obtained on saponification of the product; cholesterol acetate ($C_{26}H_{43} \cdot O \cdot C_2H_3O$) and its isomerides thus give the number 135.5.

METHYL IODIDE TEST—ZEISEL'S TEST.

Compound ethers of methylic alcohol and its next higher homologues do not appear to have been hitherto recognised as

important constituents of natural fixed oils and fats, although the corresponding compounds of the higher homologues of methylic alcohol, such as cetylic alcohol, are well marked constituents of certain cetacean oils, waxes, &c. Many essential oils, however, contain constituents of analogous character—*e.g.*, oil of wintergreen, largely consisting of *methyl salicylate*, $C_6H_4 \left\{ \begin{array}{l} OH \\ CO \cdot O \cdot CH_3 \end{array} \right.$. Another class of essential oils containing the methoxyl group ($O \cdot CH_3$) also exists, where the hydrogen displaced by methyl is alcoholiform in character, and not contained in the organic acid group $CO \cdot OH$; thus, *anethol* or anise oil camphor is the methylic ether of a phenoloid derived from allyl-benzene, $C_3H_5 \cdot C_6H_4 \cdot O \cdot CH_3$. When substances containing a methoxyl group are heated in contact with hydriodic acid, a reaction is brought about whereby the methyl group is eliminated in the form of *methyl iodide*, thus—

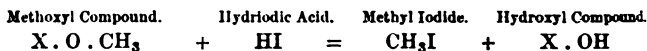

A test for the presence of methoxyl in certain bodies (*e.g.*, codeine) based on this action was employed by the author as far back as 1871,* the methyl iodide vapours evolved being passed through a red hot combustion tube containing lead chromate, so as to burn the methyl iodide, the resulting carbon dioxide being absorbed by potash bulbs in the usual way. Zeisel † has modified the process by determining the iodine contained in the methyl iodide produced instead of the carbon; for this purpose the vapours of methyl iodide evolved are carried off by a stream of carbon dioxide and received in bulb tubes containing alcoholic silver nitrate, intercepting vessels, &c., being employed to prevent vapours of hydriodic acid or iodine from passing over also. On standing, diluting with water, and adding nitric acid, silver iodide is precipitated, the weight of which is a measure of the amount of methyl iodide formed, and consequently of the proportion of methoxyl-containing substances present.

Fig. 33 represents the arrangement employed by Benedikt and Grüssner; a few decigrammes of substance are heated with 10 c.c. of hydriodic acid solution of sp. gr. 1.70 in the flask A, warmed by means of a glycerol bath; a current of carbon dioxide is led through the flask, the issuing vapours passing through a 3-bulb condenser, bulb I. being empty to condense steam, &c.; bulb II. contains water to absorb hydriodic acid; and III., red phosphorus and water to retain any traces of free iodine

* *Proceedings of the Royal Society*, xx., p. 8 (1871).

† *Journ. Soc. Chem. Ind.*, 1886, p. 335; from *Monatsh. f. Chemie*, vi., p. 989. See also *Journ. Soc. Chem. Ind.*, 1889, pp. 735 and 925 (Benedikt and Grüssner).

evolved by decomposition of hydriodic acid by heat. After passing through the bulbs the carbon dioxide, mixed with methyl iodide vapour, is led into the flask B containing 5 c.c. of a 40 per cent. solution of silver nitrate and 50 c.c. of 95 per cent. alcohol; the safety flask D contains 1 c.c. of the same silver solution with 10 c.c. of alcohol, but is usually unnecessary, all methyl iodide being retained in the first flask B.

Substances containing ethoxyl ($O.C_2H_5$) and homologues are similarly affected; as the molecular weight of the alkyl iodide formed increases, slight differences in manipulation become necessary, principally consisting in the employment of a higher temperature to enable the alkyl iodide vapours to pass over; for which reason the method is only applicable to the lower members of the series and not to compound ethers of the higher alcohols, such as cetylic alcohol.

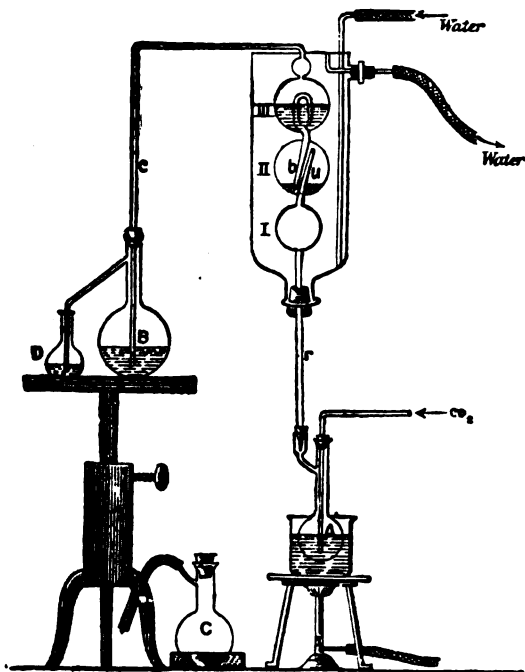

Fig. 33.

The term "methyl number" is conveniently employed to indicate the weight of methyl ($OH_3 = 15$) equivalent to the silver iodide thus formed from 1000 parts by weight of substance; if a weight w milligrammes of substance give n milli-

grammes of silver iodide (equivalent to $n \times \frac{15}{235}$ milligrammes of CH_3) the methyl number, M , is obviously given by the equation—

$$M = \frac{n}{w} \times \frac{15,000}{235}$$

$$= \frac{n}{w} \times 63.83$$

Thus, 296.3 milligrammes of oil of cloves gave 373.7 milligrammes of silver iodide, whence $M = \frac{373.7}{296.3} \times 63.83 = 80.5$.

The theoretical methyl number for pure *eugenol*, $\text{C}_{10}\text{H}_{12}\text{O}_2$, or $\text{C}_3\text{H}_5 \cdot \text{C}_6\text{H}_3 \left\{ \begin{array}{l} \text{OH} \\ \text{O} \cdot \text{CH}_3 \end{array} \right.$ is 91.5; whence the sample examined con-

tained $\frac{80.5}{91.5} = 87.9$ per cent. of *eugenol*. Similarly, a sample of anise oil gave the methyl number 82.8; since pure *anethol*, $\text{C}_3\text{H}_5 \cdot \text{C}_6\text{H}_4 \cdot \text{O} \cdot \text{CH}_3$, corresponds with the methyl number 101.4, the sample contained $\frac{82.8}{101.4} = 81.6$ per cent. of *anethol*.

The results of the various quantitative tests above described may be conveniently tabulated as follows:—

I.—VALUES RECKONED PER 1,000 PARTS OF OIL, FAT, OR WAX, &c., EXAMINED, OR DEDUCED FROM FIGURES THUS CALCULATED.

Total acid number = Saponification number = Kættstorfer number = Total acid potash permillage (*Verseifungszahl*).

The weight of potash ($\text{KOH} = 56.1$) requisite to saponify completely 1,000 parts by weight of substance, including that neutralised by any free acids present.

Saponification Equivalent.—The number of milligrammes of substance capable of furnishing on saponification fatty acids sufficient to neutralise 1 c.c. of normal alkaline solution (containing or equivalent to 56.1 milligrammes of potash, KOH); any free fatty acids present being also included. When the total acid number is K , the saponification equivalent, E , is given by the equation

$$E = \frac{56,100}{K}$$

Free acid number = Free acid potash permillage (*Säurezahl*). The weight of potash ($\text{KOH} = 56.1$) requisite to neutralise the

free acids present in 1,000 parts by weight of substance. If K be the total acid number, and A the free acid number, then $\frac{A}{K} \times 100$ represents the proportion of free acids present per 100 of total acids, assuming the mean equivalent to be the same in each case.

Ester number = Compound ether potash permillage (*Ätherzahl*; *Esterzahl*). The difference between the total acid number and the free acid number, or value of $K - A$; expressing the weight of potash ($KOH = 56.1$) requisite to neutralise the acids formed by the saponification of the compound ethers, glycerides, &c., present in 1,000 parts of substance.

The yield of glycerol, theoretically obtainable from an oil or fat consisting of triglycerides (with more or less free fatty acids), is $0.05466 \times S$ per cent., where S is the ester number = $K - A$.

Insoluble acid number = insoluble acid potash permillage. The weight of potash ($KOH = 56.1$) required to neutralise the fatty acids, insoluble in boiling water, obtained from 1,000 parts of substance.

This figure must not be confounded with the "Hehner number" (*Hehner'sche Zahl*) expressing the percentage (not permillage) of insoluble acids yielded by the substance.

Soluble acid number = soluble acid potash permillage. The weight of potash ($KOH = 56.1$) required to neutralise the fatty acids, soluble in boiling water, obtained from 1,000 parts of substance.

Obviously the total acid number, K , = the sum of the insoluble acid number and the soluble acid number. In practice, the soluble acid number is usually best determined by subtracting the insoluble acid number from the total acid number (p. 168)—*i.e.*, the soluble acid number is $K - N$, where N is the insoluble acid number.

Volatile acid number = volatile acid potash permillage. The weight of potash ($KOH = 56.1$) requisite to neutralise the volatile fatty acids obtained from 1,000 parts of substance.

The Reichert number (*Reichert'sche Zahl*) being the number of c.c. of decinormal alkali required to neutralise the volatile acids obtained from 2.5 grammes of substance by employing the particular mode of operating described by Reichert (p. 173), if n be the Reichert number, the corresponding "volatile acid potash permillage" will be $n \times \frac{5.61}{2.5} = n \times 2.244$. This value is necessarily somewhat below the true "volatile acid number" obtainable by continuing the distillation until the whole of the volatile acids have passed over.

If Meissl's modification of the Reichert test be employed (p. 174), 5 grammes of substance being taken instead of 2.5, if

m be the Reichert-Meissl number (*Reichert-Meissl'sche Zahl*), the corresponding volatile acid potash permillage will be $m \times 1.122$; as before this value will be below that corresponding with the total amount of volatile acids present.

If K be the "total acid number," and V the "volatile acid number," then $\frac{V}{K} \times 100$ represents the percentage of volatile acids (expressed in terms of some given acid) reckoned per 100 of total acids present free and combined as glycerides, &c., (similarly expressed)—*i.e.*, the percentage of acids that are volatile, reckoned on the sum of the volatile and nonvolatile acids, and assuming these to have the same equivalent weight.

Methyl Number.—The weight of methyl ($\text{CH}_3 = 15$) equivalent to the silver iodide formed from the alkyl iodide vapours evolved on heating 1,000 parts by weight of substance with hydriodic acid.

II.—VALUES RECKONED PER 100 PARTS OF OIL, FAT, OR WAX, &c., EXAMINED.

Iodine number = iodine percentage = Hübl number (*Iodzahl*). The maximum weight of iodine capable of combining with 100 parts of substance; or the weight of iodine equivalent to the sum of the chlorine and iodine (or bromine and iodine) requisite to saturate 100 parts of substance.

Hehner number = *Hehner'sche Zahl*. The weight of fatty acids insoluble in boiling water yielded by 100 parts of substance.

III.—VALUES RECKONED PER 1,000 PARTS OF THE FREE FATTY ACIDS FORMED ON SAPONIFICATION, OR DEDUCED FROM FIGURES THUS CALCULATED.

Fatty acid neutralisation number = potash permillage requisite for neutralisation of mixed free fatty acids, reckoned per 1,000 parts of fatty acids (*Verseifungszahl der Fettsäuren*). The weight of potash ($\text{KOH} = 56.1$) required to neutralise 1,000 parts of the mixed fatty acids obtained by saponification of a fat or oil, &c., and separation of fatty acids from the resulting soap.

Mean Equivalent of the Fatty Acids.—The number of milligrammes of mixed fatty acids requisite to neutralise 1 c.c. of normal alkaline solution (containing or equivalent to 56.1 milligrammes of potash, KOH). If N be the neutralisation number, the mean equivalent F is given by the equation

$$F = \frac{56,100}{N}.$$

In the case of an oil, &c., consisting wholly of triglycerides (*i.e.*, where the free acid number is so small as to be negligible), the saponification equivalent of the oil, E, and the mean equivalent of the fatty acids obtainable therefrom, F, are related thus—

$$E = F + 12.67.$$

If, however, the oil contain free acids in measurable quantity the relationship is

$$E = F + \frac{S}{K} \times 12.67,$$

where S is the ester number and K the total acid number of the oil.

The fatty acid neutralisation number, N, and the total acid number of the original oil, K, are related thus—

$$N = \frac{E}{F} K.$$

IV. VALUES RECKONED PER 100 PARTS OF FREE FATTY ACIDS FORMED ON SAPONIFICATION.

Iodine Number of Free Fatty Acids (Iodzahl der Fettsäuren).—The maximum weight of iodine (or iodine equivalent to the sum of chlorine and iodine or bromine and iodine) capable of combining with 100 parts of free fatty acids.

If I be the iodine number of the original oil, &c., and I' that of the fatty acids thence obtained, then

$$I' = \frac{E}{F} I.$$

In the case of an oil, &c., consisting substantially of triglycerides, so that $E = F + 12.67$, and where the mean equivalent of the free fatty acids lies between 250 and 330, the value of $\frac{E}{F}$ lies between 1.0507 and 1.0384—*i.e.*, the iodine number of the fatty acids exceeds that of the original oil by close to 4.5 per cent. of the latter value.

V. VALUES RECKONED PER 1,000 PARTS OF PRODUCT OF ACETYLATION OF FREE FATTY ACIDS.

Acetyl Number = Acetyl potash permillage (*Acetylzahl*).—The weight of potash (KOH = 56.1) neutralised by the acetic acid formed on saponification of 1,000 parts of the product of the action of acetic anhydride on the substance examined.

The acetyl number as thus defined includes both the titration value obtained by Benedikt and Ulzer, conveniently referred to as the *titration acetyl number*; and the result of applying the distillation process so as to separate acetic acid, as proposed by Lewkowitsch, conveniently distinguished as the *distillation acetyl number*. Like the volatile acid number, this latter value is always apt to be more or less erroneous in defect on account of the difficulty of distilling off and titrating every trace of acetic acid.

On the other hand, in the case of free fatty acids very little dependence can be placed on the former number, although for alcoholiform substances this objection does not apply.

§ 4. Processes Used for Extracting, Rendering, Refining, and Bleaching Oils, Fats, &c.

CHAPTER IX.

EXTRACTION OF OILS FROM SEEDS, &c., BY PRESSURE OR SOLVENTS.

EARLIER FORMS OF PRESS.

THE use of olives and various kinds of seeds and nuts as sources of oil has been known from at least the commencement of the historic period, the earliest appliances for the expression of the fluid consisting of "mills" somewhat after the fashion of the primeval corn grinding hand mills, where a rounded stone was made to revolve in a basin shaped stone vessel by means of projecting handles, worked usually by two women seated on the ground on opposite sides of the mill;* the pulp thus produced was then placed in sacking and pressed by means of planks weighted with stones, very much as grape juice was expressed in the earliest forms of wine press; or a powerful lever was applied, somewhat after the style of an enormous lemon squeezer. Various forms of lever press have been in use at different times, some of more complex order than the simple lemon squeezer type of machine, a bent lever working a cam pressing upon the upper board so as to force it downwards; or the pressure board being arranged vertically, and the sacking being compressed between it and a stout vertical standard, such as the stump of a tree. Double action presses of this kind, working alternately, have also been constructed. A further improvement in oil pressing appliances was the introduction of wedges between the pressure boards, actuated by levers and cams or by percussion; in the latter case, the press consisted of a stout framework of beams, inside of which the pressure boards and seed bags were arranged, so that by hammering in wedges between adjacent pairs of boards, or between the boards and the framework, the seed bags were gradually compressed and finally subjected to considerable

* "There shall be two women grinding together; the one shall be taken, and the other shall be left."—Luke xvii. 35.

pressure. Even at the present day lever presses and wedge presses of a more or less rude manufacture, but of considerable practical efficiency, are still in use to a considerable extent amongst these nations and in those districts to which improved machinery and engineering appliances have not yet penetrated—e.g., in China and some parts of Japan*—whilst improved modifications of the older lever press, constructed with elbow levers actuated by steam or water power, are employed with advantage for various oil and grease expression purposes (p. 202).

Screw presses have also been extensively used, and are still largely employed in the smaller factories; but of late years they have been mostly superseded by hydraulic presses in the larger and more modern seed oil mills. In similar fashion various forms of appliances have been successively introduced and used for the crushing of oleiferous material, and otherwise treating it previously to expression, so as to render the flow of oil more easy and complete; thus pairs of crushing rollers working on parallel axes so as to squeeze the olives, seeds, &c., introduced between them, and "edge runners" (Fig. 48) arranged like a mortarmill, are more recent developments which have, for the most part, superseded the older form of "stamps" where mechanically worked pestles pounded the seed, &c., to be crushed in large basins or mortars.

Even at the present day a considerable amount of oil of various kinds is manufactured (on the small scale) by a process probably of greater antiquity still than any mechanical expression method. In most tropical and subtropical countries oleiferous seeds and nuts of various kinds abound; in order to extract the oil these are simply pounded or crushed and then boiled with water, the oil rising to the top and being skimmed off. Experience has generally guided the natives to the use of a previous *roasting* of the nuts or beans, the effect of the heat being to coagulate and solidify mucilaginous and albuminous matter, rendering the after separation of the oil by means of water much more easy and complete. Castor oil, for example, is thus largely extracted for local use in India; palm oil and palmtree oil, until comparatively recently, were almost wholly prepared by this method, all the oil shipped from Africa having been extracted by a water-boiling process applied to the pulp and roasted kernels; of late years, however, it has been more usual to separate the kernels from the pulp and export them untreated, the oil being subsequently extracted by the ordinary expression or solvent processes.

In the rural olive producing districts a considerable amount of oil is prepared by a sort of combination of the two methods,

* For a description of a peculiar form of wedge press used in Formosa for the extraction of olive oil, see Report by Consul Warren on the trade of Taiwan, *Journal Soc. Chem. Industry*, 1891, p. 556.

the appliances being somewhat rude and primeval in the smaller oil factories, but more modern in the larger ones. The crushed pulp is washed by agitation with water, the oil as it separates from the husks and rises to the top running off along with water to separation tanks; the residual wet oil-containing husks are strained and boiled down to a kind of porridge or soft pulpy dough, and the oil mixed with water then separated by pressure in some sort of rough screwpress. In some cases the resulting marc is ground up again by heavy edgerunners of granite, &c. (worked by water or cattle power), boiled up afresh with water, and subjected to further pressing.*

A somewhat analogous process is sometimes used in the extraction of the fat or "butter" of the tallow tree (*Stillingia sebifera*), and other vegetable semisolid oils or fats; the crushed seeds, nuts, &c., are placed in wicker or bamboo baskets, weighted with stones under boiling water, so that the melted fat gradually separates and rises to the top; the remaining oil is then extracted by pressure applied to the still hot material. This method is more particularly suited to those nuts, &c., where the kernel is surrounded with a highly oleaginous pericarp, which is thus melted away by a process closely akin to that whereby animal fats are "rendered" by means of steam or boiling water (*vide* Chap. x.) Processes closely analogous in general character are in use in various countries for the extraction of oil from fish of various kinds (*e.g.*, sardines), and from fish and shark livers, whilst the mode of preparation of most kinds of wax is very similar; thus in the case of Chinese wax (*Peh-la*), the insect producing the wax is a species of *coccus* (possibly several different species), the young brood of which sticks to, and punctures the bark and twigs of the trees (*Fraxinus chinensis*, *Ligustrum lucidum*, &c.) selected as domicile. A waxy material is secreted † covering the bark, in which the insects ultimately imbed themselves, forming chrysalides. To obtain the wax, the branches are scraped, some of the cocoons being reserved for breeding, the rearing of the insects being a special industry like silk growing; the scrapings are heated with boiling water so as to melt off the waxy matter, which is separated by skimming from the dirt, dead insects, &c.

The different kinds of vegetable wax (myrtle wax, Japanese wax, carnauba wax, &c.), are mostly obtained by similarly treating with boiling water the berries, bark, &c., in or on which the material is naturally secreted or deposited, and separating the melted wax as it rises. Bees' combs, &c., are similarly

* Descriptions of the appliances in use in the Maritime Alps and in Southern Sicily for the preparation of olive oil are given in the *Journal Soc. Arts.*, Nov. 20, 1891, and June 16, 1893.

† As with beeswax, opinions differ somewhat as to how far the wax is precontained in the sap of the trees serving as food, and how far it is formed or altered by animal life action.

treated to obtain beeswax, and separate it from adherent honey and solid impurities.

Elbow Press.—Although the older rude forms of lever press and wedge press are rapidly being superseded by more modern devices, more especially by hydraulic pressure, they are still by no means extinct amongst those peoples where advancing

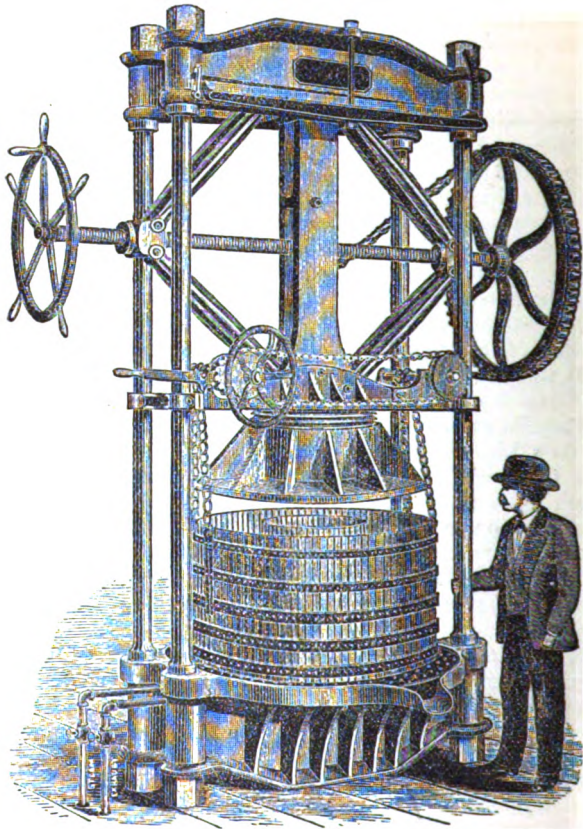

Fig. 31.—Elbow Press.

civilisation has not yet entirely improved away the ancient methods and customs, whilst improved machines of these classes are still in active use to some extent even in Europe and America. Fig. 34 represents a form of "elbow press," largely used in the United States for expressing hot melted tallow, &c., from animal adipose tissue. As the screw is worked (by hand

wheel or band and pulley) the two powerful elbows are straightened, and the ram depressed; owing to the mechanical nature of the action, the pressure is automatically increased towards the end of the operation as the elbows straighten.

Wedge Press.—An improved form of wedge press is represented by Figs. 35 and 36 (from Schädler) in front and side elevation, Fig. 37 indicating the longitudinal section of the lower portion. Inside each of a pair of troughs, J J, is placed an arrangement of wooden wedges and planking, B L S K B,

Fig. 35.

Fig. 36.

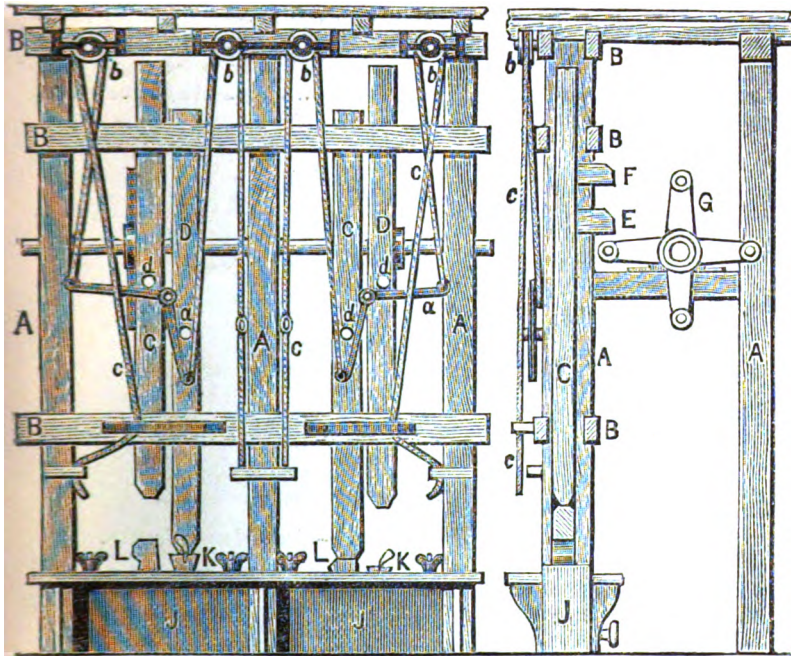

Wedge Press—Front and Side Elevation.

together with two bags containing the crushed seed, &c., to be expressed, O O, each enclosed between cast iron frames, T P. The "loose-wedges," L L, are suspended by ropes, and serve to lock the whole arrangement together, the loosening when the pressure is completed being effected by casting off the ropes and allowing the suspended vertical beams, C C, to descend, pile-driver fashion, so as to drive these wedges, L L, down; A A, B B represent a stout timber frame supporting the driving beams. The pressure is obtained by similarly forcing downwards the "press-wedges,"

K K, by the beam drivers, D D. These drivers are raised by means of stout teeth, G, projecting from a horizontal axle working on studs, E and F, attached to the beams respectively, a system of ropes, *b, c*, bent lever, *a*, and studs, *d, d*, being attached, so that when the ropes are pulled, either of the drivers can at will be raised so as to bring it out of the reach of the teeth, and keep it suspended out of action. The oil bag, being placed in position between the plates, T P, of the iron frames, L, is adjusted at a convenient height by means of the attached rope. The drivers, D, being then set in action, the press wedge, K, is forced down, and the oil bag consequently strongly compressed. When the oil ceases to run and the wedge is driven home, D is thrown out of action and C allowed to hammer on the loose wedge (the rope attached being slackened); the loose wedge, L, soon falls, and the bags with exhausted oilcake are then removed and fresh ones substituted.

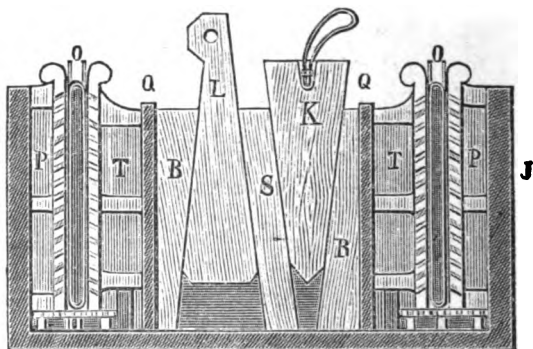

Fig. 37.—Wedge Press—Longitudinal Section of Lower Portion.

In some of the Marseilles oil factories an arrangement is in use known as the "Estrayer Cylinder,"* the action of which is somewhat akin to that of the wedge press. The apparatus consists of two cylinders, one inside the other, of which the outer acts upon the inner by means of a series of inclined planes, the inner cylinder being composed of eight segments which either close up tightly or separate slightly according as pressure is exercised or removed by the position of the outer cylinder. Screens made of esparto grass and horsehair are employed instead of oilbags of the same material ("scourtins") such as are employed in other forms of press; these are subject to much less wear and tear than the scourtins, whereby an economy of 80 to 90 per cent. in the cost of the scourtins is effected. An

* *Journ. Soc. Chem. Ind.*, 1893, p. 49.

interior movement allows of the cylinder being enlarged in diameter, so that the cakes can be readily removed. The apparatus will withstand a pressure of 500 kilos per square centimetre ($63\frac{1}{2}$ cwts. per square inch); half of this is as much as can be safely applied to the ordinary bags without great risk of bursting them. A cylinder holding 80 to 100 kilos of seeds can be discharged and refilled in 7 to 8 minutes, the pressing occupying 30 to 35 minutes.

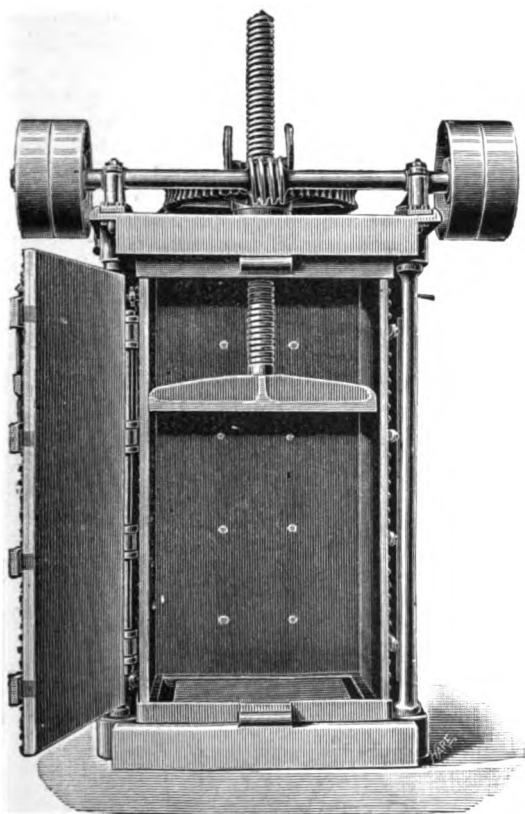

Fig. 38.

Screw Press.—In districts where more modern machinery has not been extensively adopted (*e.g.* many parts of Spain, China, West Indies, South America, Africa, &c.), rude screw presses are still largely in use in the comparatively small oil mills where oil is expressed in much the same fashion as has been practised for centuries; these mostly work on the principle

of an ordinary copying press, the sacking (or wicker or straw basketing, &c.) containing the material to be expressed being placed between the two plates of the press, and the screw (frequently of wood) turned by means of a long lever so as to bring the plates nearer together and express the oil, much as a wet sponge would be squeezed in a copying press by turning the handle.

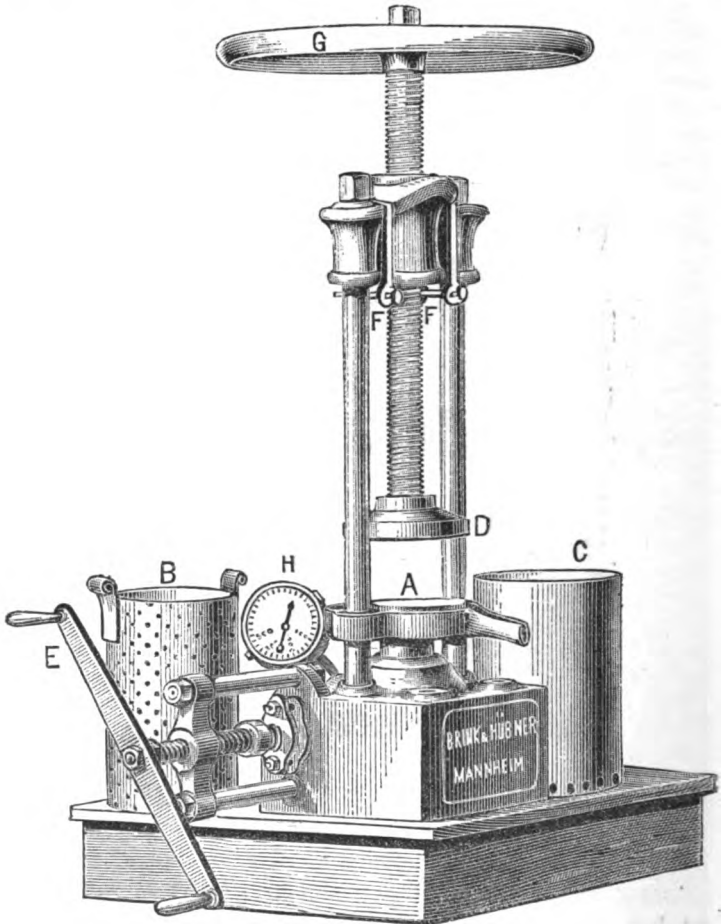

Fig. 39.

Fig. 38 represents an English improved form of screw press for expressing oil, &c., from fish or similar materials where only a moderate pressure is required. Motion is communicated by

belts from shafting to a horizontal axle carrying a worm which gears into a toothed wheel, the revolution of which raises or depresses the screw passing concentrically through the wheel, and consequently elevates or lowers the plunger. According as a straight belt is used connected with one pair of fast and loose pulleys on the axle, or a crossed belt connected with the other pair, the plunger moves in one direction or the other. The material to be pressed is placed in bags between loose metal plates, the press itself being enclosed in a wrought iron steam casing (stayed to resist pressure) provided with a steam-heated door of similar construction, so that when requisite the temperature inside the press can be elevated up to that of the steam or nearly so.

Fig. 39 represents a screw press of German make. The material to be expressed is placed inside the perforated cylinder B, which is then placed inside the cylinder, C, and mounted on the platform, A; the ram, D, attached to the screw, F F, being raised to a convenient height. On turning the horizontal wheel, G, the screw and ram descend and the material is strongly compressed in the inner cylinder. The expressed liquid passes through the perforations in the walls of B and runs out through others at the base of C into a circular groove in the platform, A, and thence by the spout to a vessel placed to receive it. A small hydraulic arrangement is attached at the base, such that by turning the handle, E, a piston is screwed slowly inwards, thus raising a hydraulic ram on to the top of which the platform, A, is fixed, and so obtaining at the end of the operation a more powerful pressure than would be possible by means of the screw, F F, alone.

Hydraulic Press.—The ordinary form of hydraulic press as adapted for oil expression consists of a ram raised by admission of water into its cylinder, either intermittently by pumps (worked by hand or power) or continuously from an accumulator. The former method is preferred for many purposes, since the pulsating pressure obtained by means of a pump appears to be better adapted for the expression of oil from most kinds of seeds, &c., than the continuous steady pressure of an accumulator. Presses in which the ram works horizontally instead of vertically are sometimes preferred. Fig. 40 represents a German form of hydraulic press, empty before charging, and Fig. 41 the same after the ram has risen. The bags are placed in the cavities of the shelves or press boxes, E E E, and the ram started working. As it rises each bag is strongly compressed between the base of the press box containing it and the projecting lower portion of the box next above it; the oil runs out into the circular grooves, F F, and thence to delivery spouts, J J, and so through the pipes, G G, to the vertical oil shoot, H, leading to the oil well or tank. The headpiece of the press, C, is supported by stout pillars, D D, to resist the strain.

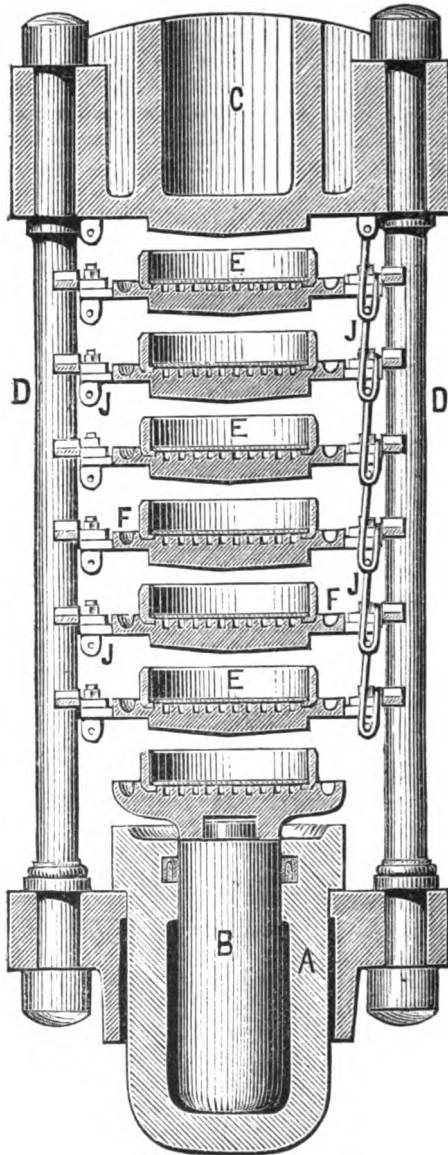

Fig. 40.—Hydraulic Press (German Form).

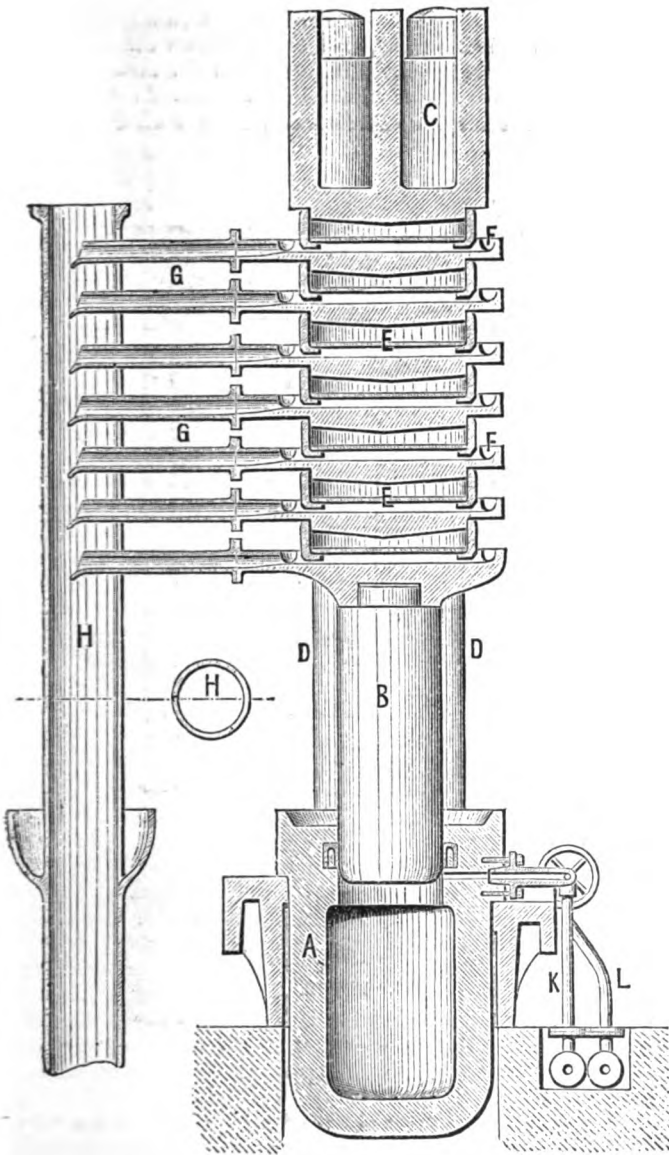

Fig. 41.

Fig. 42 represents an English handworked hydraulic press, specially suitable for light work such as that in a small olive oil mill. The press being filled, the larger of two differently sized pumps attached to it is worked by means of the detachable lever handle, until the bulk of the oil is expressed; to obtain a stronger pressure for the extraction of the remainder, the lever

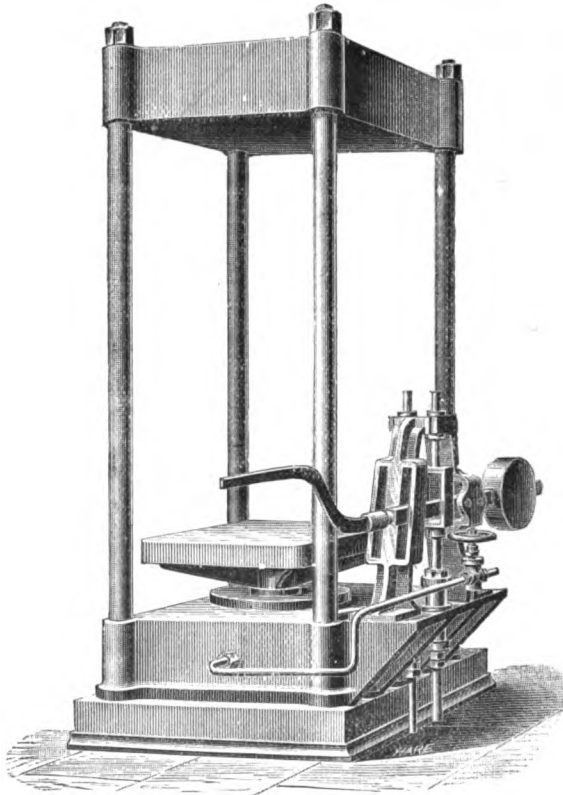

Fig. 42.

handle is then applied to a second smaller pump arranged by the side of the first one, whereby a considerable increment in power is obtained.

Fig. 43 represents a press arranged for working on the "Anglo-American System" (*vide infra*). The plates are corrugated, and arranged at such distances apart as just to allow of the moulded cakes of hot ground seed, &c., from the kettle and moulding

machine (p. 221) being introduced, preferably from each opposite side alternately. Usually sixteen cakes are pressed simultaneously in one press, whilst four such presses are worked together in one block, all four being erected inside the same wrought iron oil tank, which serves as a foundation and collects the expressed oil in a most efficient manner. The pressure employed usually rises from 700 or 800 lbs. per square inch at first up to 2 tons at the end. Fig. 44 represents the plan and longitudinal section of one of the press plates, Fig. 45 indicating the cross-section.

The dimensions of the oil-cakes produced vary considerably with the size of the oil mill, the system of working, and the nature of the seed, &c., used; the cakes are always made to taper somewhat so as to facilitate withdrawal from the cake boxes. Thus with the smallest mills the cakes may weigh about 3 lbs., and the dimensions may be 14 inches long, and $6\frac{1}{2}$ inches wide at one end and $5\frac{1}{2}$ at the other, the press being constructed to take from 4 to 6 such cakes at a time; whilst with somewhat larger mills the cakes may weigh about 4 lbs., being 20 inches long, and $7\frac{1}{2}$ wide at one end by $5\frac{1}{2}$ at the other. Still

larger cakes (up to some 30 inches long, and 10 or 11 wide at one end and 7 or 8 at the other) are made in mills of greater magnitude (especially when working linseed), where the scale of manufacture is large enough to enable full-sized presses, &c., to be employed. Such a linseed cake generally weighs from 6 to 13 lbs., averaging about 8 or 9 lbs., varying with the source and richness in oil of the seed used; the weight of the pressed oilcake obtained from a given quantity of seed is obviously the less the larger the yield of oil. When working on the older system the press usually contains only four cake boxes, three such presses being worked

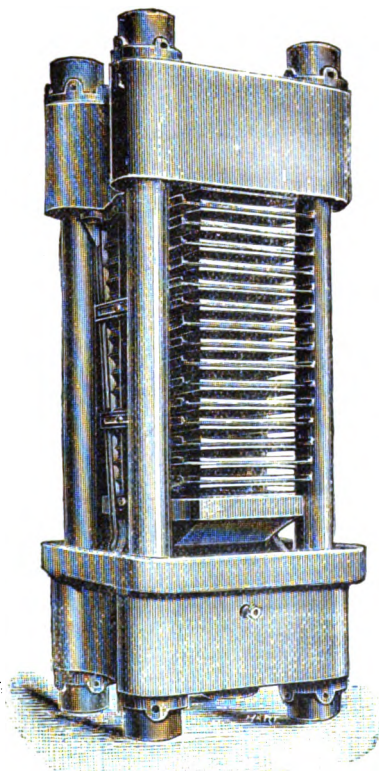

Fig. 43.

THE
LAW
OF
THE
STATE

THE
LAW
OF
THE
STATE

THE
LAW
OF
THE
STATE

THE
LAW
OF
THE
STATE

THE
LAW
OF
THE
STATE

THE
LAW
OF
THE
STATE

neated and pressed hot; the oil thus obtained is far inferior to either of the former runnings. The oilcake thus left often retains a sufficient quantity of oil to render it worth while to treat by some solvent extraction process (p. 231), whereby a still lower grade of oil is ultimately obtained. This mode of treatment in several stages is more especially adopted in the case of higher class edible oils—such as those from the arachis nut, and from sunflower seed; or in the production of the more highly priced oils used for other purposes—*e.g.*, almond oil. Coarse oils, such as linseed, are usually expressed but once, the pulp being heated to commence with as described below, partly to render the oil more fluid, and partly to coagulate albuminous matter. Some kinds of seeds, however (*e.g.*, sesamé and rape), are generally treated in two stages—*i.e.*, pressed twice successively so as to obtain two qualities of oil. When the cakes are removed from the press, the cloths are stripped off and the edges pared off; the parings contain a notable amount of oil, and are therefore ground up and mixed with fresh crushed seed for another batch.

In some cases mixtures of seeds are intentionally prepared and crushed and treated together; in others the seed as harvested is a mixture, two or more kinds of plants being grown together; so that, excepting when the seeds differ sufficiently in size to be capable of separation by sifting, the oil ultimately obtained is necessarily of a mixed character. Partly from causes of this kind, and partly on account of subsequent adulteration, it is difficult, if not impossible, to obtain an absolutely pure oil of any given kind in commerce, the only practicable method of procuring a perfectly pure sample being to hand-pick the seeds and express the oil in a small press kept for such purposes. Accordingly, a small press for the purpose of preparing samples of genuine seed oils from time to time is an indispensable part of the equipment of a laboratory where oil examinations are made by comparison of the substances tested with specimens of oils and mixtures of oils known to be themselves unadulterated.

Composition of Oilcake.—The analyses quoted on p. 214 are given by Schädler, as representing the average composition of oilcakes of various kinds.

According to Voelcker, linseed cake made by the older system usually contains from below 10 to about 16 per cent. of oil, and cotton seed cake from 6 per cent. (undecorticated) up to 16 per cent. (decorticated). Oilcakes made by the Anglo-American system of working are usually more completely expressed, so as to contain distinctly smaller percentages of residual oily matter than cakes prepared without the aid of a moulding machine. If, however, the expression be carried too far, the value of the cake as cattle fodder is greatly diminished, so that in extreme cases it may be rendered unsaleable.

by one man and a boy, including paring and storing the cakes; the presses are charged from three to six times an hour, according to the seed used (cotton seed about four times, linseed five). With some kinds of seed (*e.g.*, rape and gingelly) the crushed seed is worked over twice, two presses being employed for the first expression and three for the second—the press cake pro-

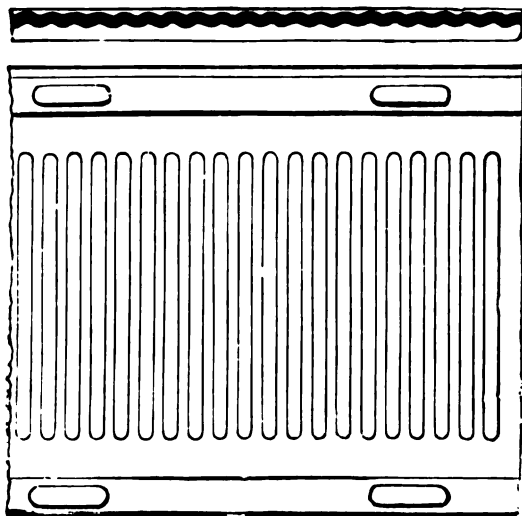

Fig. 44.

duced by the first treatment being reground before the second expression, usually by means of edge runners (p. 219). Seeds less rich in oil than linseed and cotton seed yield proportionately heavier cakes for the same weight of seed; as a rule, with the less oleaginous seeds, &c., a better yield is obtained by pressing proportionately smaller quantities at a time, so as to form in all cases oilcakes of about the same thickness.



Fig. 45.

With certain kinds of seeds furnishing "salad" oils of finest character, the expression is carried out in three stages:—First of all cold pressure is applied to a moderate extent, whereby a "cold-drawn" oil is obtained of the purest quality (after refining, *i.e.*, removal of mucilage, &c.). Then the cake is again ground, slightly moistened with water, and pressed a second time, using somewhat higher pressure; the oil thus obtained is cold-drawn oil of second quality. Finally, the cakes are again ground and

heated and pressed hot; the oil thus obtained is far inferior to either of the former runnings. The oilcake thus left often retains a sufficient quantity of oil to render it worth while to treat by some solvent extraction process (p. 231), whereby a still lower grade of oil is ultimately obtained. This mode of treatment in several stages is more especially adopted in the case of higher class edible oils—such as those from the arachis nut, and from sunflower seed; or in the production of the more highly priced oils used for other purposes—*e.g.*, almond oil. Coarse oils, such as linseed, are usually expressed but once, the pulp being heated to commence with as described below, partly to render the oil more fluid, and partly to coagulate albuminous matter. Some kinds of seeds, however (*e.g.*, sesamé and rape), are generally treated in two stages—*i.e.*, pressed twice successively so as to obtain two qualities of oil. When the cakes are removed from the press, the cloths are stripped off and the edges pared off; the parings contain a notable amount of oil, and are therefore ground up and mixed with fresh crushed seed for another batch.

In some cases mixtures of seeds are intentionally prepared and crushed and treated together; in others the seed as harvested is a mixture, two or more kinds of plants being grown together; so that, excepting when the seeds differ sufficiently in size to be capable of separation by sifting, the oil ultimately obtained is necessarily of a mixed character. Partly from causes of this kind, and partly on account of subsequent adulteration, it is difficult, if not impossible, to obtain an absolutely pure oil of any given kind in commerce, the only practicable method of procuring a perfectly pure sample being to hand-pick the seeds and express the oil in a small press kept for such purposes. Accordingly, a small press for the purpose of preparing samples of genuine seed oils from time to time is an indispensable part of the equipment of a laboratory where oil examinations are made by comparison of the substances tested with specimens of oils and mixtures of oils known to be themselves unadulterated.

Composition of Oilcake.—The analyses quoted on p. 214 are given by Schädler as representing the average composition of oilcakes of various kinds.

According to Voelcker, linseed cake made by the older system usually contains from below 10 to about 16 per cent. of oil, and cotton seed cake from 6 per cent. (undecorticated) up to 16 per cent. (decorticated). Oilcakes made by the Anglo-American system of working are usually more completely expressed, so as to contain distinctly smaller percentages of residual oily matter than cakes prepared without the aid of a moulding machine. If, however, the expression be carried too far, the value of the cake as cattle fodder is greatly diminished, so that in extreme cases it may be rendered unsaleable.

Oilcake from	Water.	Fatty Matter.	Cellulose and Non-nitrogenous Vegetable Matter.	Ash.	Proteids.	Nitrogen.
Arachis nuts, .	11.50	8.80	31.10	7.25	41.35	6.80
Cotton seed, .	13.00	7.50	51.00	8.50	20.00	2.90
Rape seed, . .	10.12	9.23	41.93	6.84	31.88	5.00
Colza,	11.35	9.00	42.82	6.28	30.55	4.50
Sesamé seed, .	10.35	10.10	38.80	9.80	31.93	5.00
Beechnuts, . .	11.40	8.50	49.80	5.30	24.00	3.20
Linseed, . . .	10.56	9.83	44.61	6.50	28.50	4.25
Cross seed, . .	12.23	7.68	47.00	12.50	20.50	3.00
Camelina seed,	9.60	9.20	50.90	7.00	23.30	3.60
Poppy seed, . .	9.50	8.90	37.67	11.43	32.50	5.00
Sunflower seed,	10.20	8.50	48.90	11.40	21.00	2.40
Madia,	11.86	7.90	50.00	12.24	18.00	2.50
Hemp seed, . .	10.00	8.26	48.00	12.24	21.50	3.30
Palm kernels, .	9.50	8.43	40.95	10.62	30.40	4.50
Cokernuts, . .	10.00	9.20	40.50	10.50	30.00	4.50

Nördlinger has found (p. 115) from 6 to 15 per cent. of total fatty matters contained in rape, poppy, earthnut, sesamé, palmtree, cokernut, linseed, and castor bean cakes; of which the free acids constituted fractions varying between less than $\frac{1}{100}$ and above $\frac{1}{2}$.

According to B. Dyer,* linseed cake, as made at the present day, contains, on an average, about 10 per cent. of oil, varying between 7 and 16 per cent.; of this a quantity varying between one-thirteenth and one-fifth, usually consists of free fatty acid, the proportion being less the purer the linseed. With some freshly expressed cakes, free acid is practically absent; on the other hand, with cakes that have "heated" on keeping, the greater portion of the glycerides originally present is decomposed, producing free fatty acids. Obviously, the proportion of free acid formed chiefly depends on the extent to which hydrolytic actions have taken place during storage.

OIL MILL PLANT.

The plant in use in modern oil mills varies somewhat in details according to the nature of the material to be treated, and according as the substance is intended first to be submitted to a preliminary cold pressing so as to obtain a portion of the oil as a product of finer quality, and then to hot pressings to obtain lower grades; or to be treated hot at one operation only. Further, the climate somewhat modifies the character of the process, inasmuch as many substances can be sufficiently completely expressed in a tropical climate, without any extraneous heat

* *Journ. Soc. Chem. Ind.*, 1893, p. 8.

being requisite, that would require to be artificially warmed in a colder climate to render the oil sufficiently fluid to exude properly by pressure. Again, the scale on which the operations are to be conducted, and considerations as to relative cost of labour, fuel, animal power (horses or bullocks, &c.), value of oilcake when expressed as far as practicable, or only to a lesser extent, and whether to be subsequently treated by solvent processes or not, and so forth, have also to be taken into account. In general terms, however, the plant may be described as essentially consisting of boilers and engines for steam raising for heating purposes and power; crushing machinery (rolls, edge runners, &c.) for breaking up the material so as to rupture the walls of the cellular tissues in which the oily matter is contained; heating appliances whereby the material (either as delivered from the crushers, or after a preliminary cold pressure, and subsequent disintegration of the partly expressed cake) is subjected to heat for the twofold purpose of rendering the oil more fluid, so as to facilitate expression, and of partially coagulating albuminous matter so as to obtain a purer product; hydraulic presses whereby the expression is effected; and finally, filter presses, refining tanks, settlers, and analogous appliances, whereby the crude oil is refined and more or less completely separated from watery and organic matters accompanying it when first expressed. What is now generally known as the "Anglo-American system" substantially consists in the use of a selection of particular appliances for the above purposes conjoined with a special feature—viz., that the crushed material, after damping and heating in a suitable "kettle," is subjected to a preliminary moulding operation so as to shape and compress it into compact thin blocks or "cakes," which are then expressed.

The chief advantages of this system, as employed in the plant constructed by Messrs. Rose, Downs & Thompson, of Hull, are claimed to be as follows, when contrasted with older systems of arranging and working oil mill plant:—

All the machinery is belt-driven; whereby not only is greater economy secured in the cost of gearing and greater facility in erection, but also a considerable saving (about 20 per cent.) in driving power.

The weight of the machinery requisite to work a given quantity of seed is materially reduced, whilst the process is equally applicable to all oil seeds and nuts, slight variations in the nature of the rolls, &c., being made in some cases, according to the nature of the seed, &c., treated.

The plant is less bulky, a great economy in space being effected; whilst a large saving (50 per cent.) of labour in the press room is also brought about.

The oil is more perfectly extracted; thus linseed cakes made on the old system usually contain about 10½ per cent. of oil, and

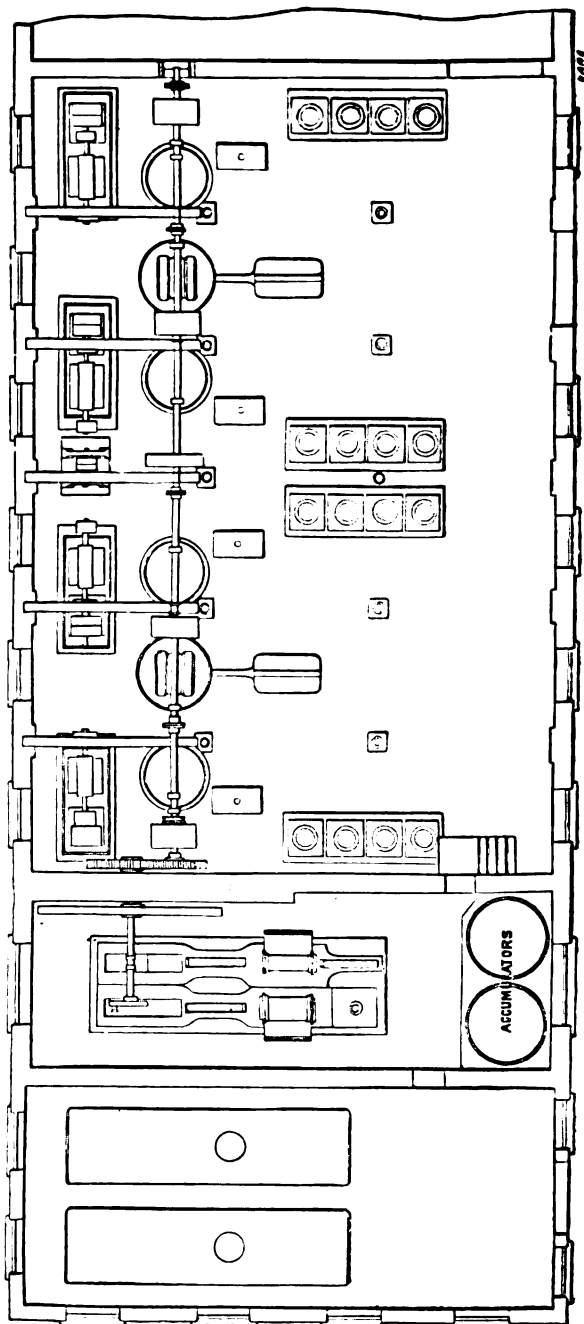

Fig. 46

those made by the modern process only about 7 per cent., giving an extra yield of oil to the extent of about $3\frac{1}{2}$ per cent. of the weight of the cake.

The bagging requisite for moulded cakes is subjected to less severe wear and tear than that used in the ordinary process; whilst the costly hair envelopes are altogether abolished. Moreover, the cakes produced have a better surface and fracture, and are better branded when the crushing is effected by rollers than when done by means of edge stones in the ordinary way.

In what is termed a "unit" mill on this system, the plant is capable of crushing from 160 to 200 cwts. of linseed or rape seed per day, or 155 to 190 cwts. of cotton seed. The seed passes down a shoot to a series of crushing rolls (usually five in number), thence by an elevator to the kettle, where it is heated; a moulding machine forms it into cakes, which are placed in presses (four standing in one oil tank) and expressed. A paring machine cuts off the oil-containing edges of the pressed oilcakes; these are ground up under small edgestones and returned to the kettle to be worked over again with a fresh batch of crushed seed. One set of four presses requires three men in the pressroom and about 45 actual horse power to work it. For larger mills, this "unit" set of plant is simply doubled, trebled, or quadrupled, and so on, each additional set requiring a further addition of about 35 actual horse power. In very large installations, where more than two sets (eight presses) are used, a system of accumulators is preferable rather than separate pumps for each set of four presses; accumulators at a lower pressure being also used for the moulding machines, cake hoists, &c., whereby a considerable saving is effected in gearing and space. Fig. 46 exhibits the ground plan of a 16-press installation containing the following plant:—

- 1 High pressure accumulator.
- 2 Low " "
- 16 Hydraulic presses, each with a hydraulic gauge.
- 1 Set of hydraulic pumps.
- 4 Sets of accumulator stops.
- 4 " seedrolls (5 rolls in each).
- 4 Seed kettles.
- 4 Moulding machines.
- 2 Paring " "
- 4 Sets of elevators.
- 2 Sets of edgestones.
- 2 Oil pumps and cisterns.
- 4 Seed screens.
- Oil cisterns to hold 200 tons of oil.
- Engine to work up to 200 actual horse power.
- Boilers " 250

together with gearing, elevators, sack lift, piping, &c.

Such an installation requires twelve men in the press room, which should measure 66 ft. by 44 ft., the whole building being

275 ft. by 44 ft., four floors. From 640 to 800 cwts. of linseed or rape seed, or from 620 to 760 cwts. of cotton seed can then be treated per day of 11 hours.

Crushing Rolls and Edge Runners.—Fig. 47 represents a set of four superposed rolls used as above described; these are 42 inches long and 16 inches diameter, and are so arranged that the seed is delivered from the hopper above (by means of a fluted feed roller the same length as the crushing rolls, and a slanting shoot), between the two uppermost rolls; having passed between

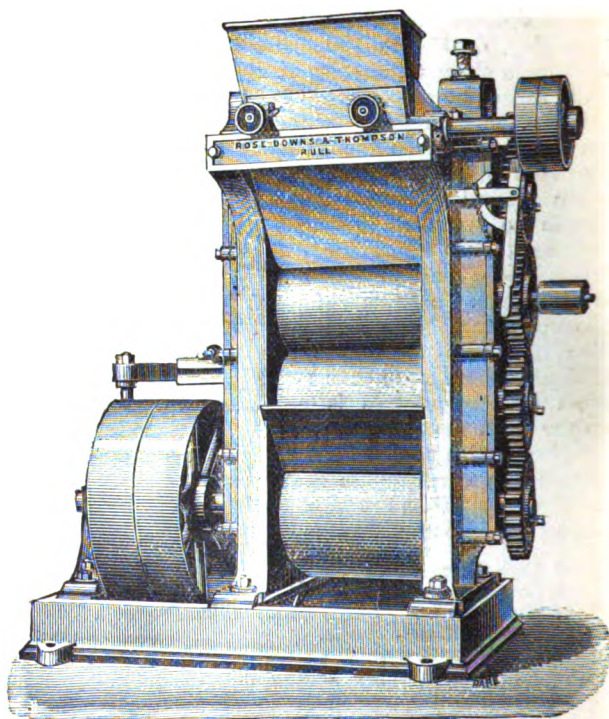

Fig. 47.

these, another curved shoot or guide plate on the other side delivers it between the second and third rolls, which crush it further; in similar fashion it passes by another guide plate between the third and fourth rolls, where it receives the final grinding. The seed is thus crushed three successive times in its passage through the rolls, which are brought into contact by a combination of a screw and india-rubber springs, thus giving a smooth and easily regulated pressure; a much more complete

and perfect grinding is thus effected than is possible with single pairs of rolls and edgestones of the older construction. When five rolls are employed in the same train, the arrangement is precisely similar, four successive crushings being effected. For small installations the rolls used are similar in character, but of proportionately smaller size; thus a set of four rolls (crushing the seeds thrice successively), each 15 inches long and 12 inches

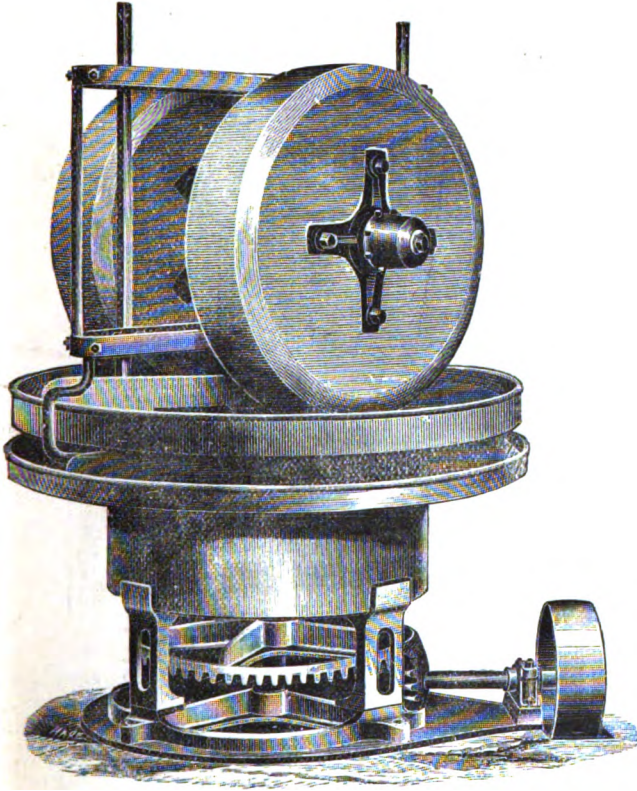

Fig. 48.

diameter, suffices for a steam driven mill of about half the capacity of a "unit;" and one of three rolls (giving two successive crushings), each 8 inches long and 8 inches diameter, for smaller sizes still, driven by bullock power.

In some oil-crushing establishments heavy edge runners are preferred to rolls for certain kinds of material—*e.g.*, Egyptian cotton seed and coprah. Fig. 48 indicates a belt-driven pair of stones, 8 feet diameter and 20 inches thick (the face being

chamfered to 16 inches); with these, about 6 tons of Egyptian cotton seed may be crushed in eleven hours. The best stones are made of well dressed Derbyshire gritstone, free from all sandholes, cracks, shells, and other imperfections, the bedstone (6 feet 6 inches diameter and 22 inches thick) being of the same material.

Smaller sized stones suffice for grinding cake parings; for the 4-press "unit" installation above described one set of stones suffices, 4 feet diameter and 12 inches thick (face 9 inches). For this purpose, two carfe plates are used instead of one, as shown

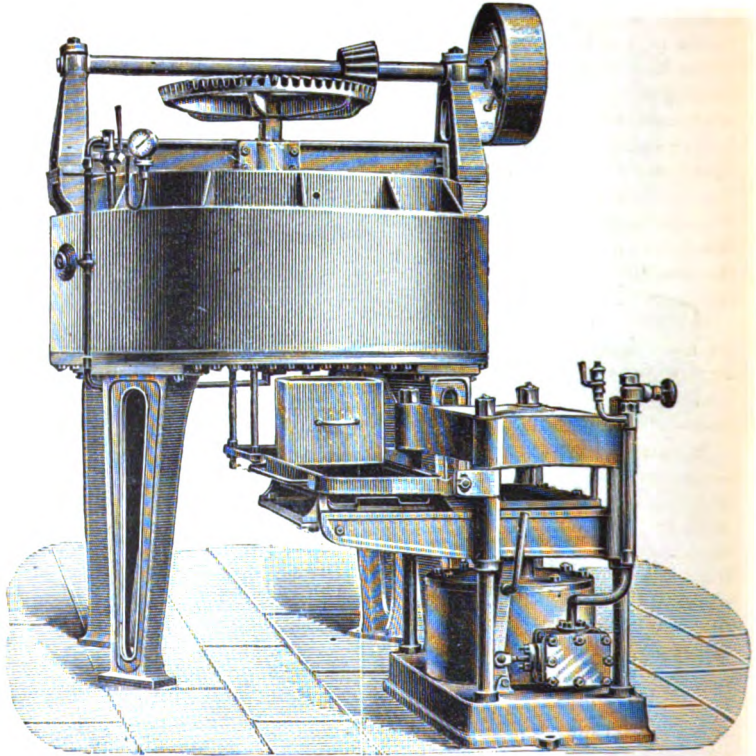

Fig. 49.

in Fig. 48, the upper one being perforated, so that the material that is being ground may pass through on to the lower one as soon as it is sufficiently pulverised; from the lower plate it is gathered together and discharged through a shuttle at any convenient point. The texture of the material thus ground is regulated by the fineness or coarseness of the perforations. In

some mills working coprah, slicing or rasping machines are employed to cut up the material before grinding; but so much damage is done to the knives by stones mixed with the coprah that this previous treatment is now but seldom employed, special disintegrators being used instead (p. 225).

Kettle.—The "kettle" used in the Anglo-American system consists of a steam-jacketted circular castiron vessel, furnished with an agitator (Fig. 49) driven by a belt; a steam damping apparatus with perforated boss is fixed inside, so that the crushed seed delivered into the kettle by an elevator is moistened by the condensation of steam from the damping arrangement, and heated up uniformly as the mass is stirred by the agitator. By means of a slide at the bottom the heated substance is delivered into a box supplying the moulding machine. The kettle body is fitted with a wooden frame, and covered over with felt or slag wool enclosed within iron sheeting to keep in the heat. In order to save space, the crushing rolls are sometimes arranged vertically above the kettle; but in addition to the inconvenience caused by this elevation as regards inspection and adjustment, the steam from the kettle is apt to condense on the rolls and clog them; so that this disposition is generally abandoned in the newer mills, the crushed seed being delivered into the kettles by means of elevators (Fig. 55) or screws, and not by gravity.

In the older system of working where moulding machines are not employed, the kettles used for heating the crushed seed, &c., are of similar character, but are usually not supplied with a damping arrangement, as the necessity for moistening the material in order to mould it better does not then arise.

Moulding Machine.—The use of this appliance is the most distinctive feature of the Anglo-American system; the differences between this and the older method of procedure may be thus stated. In the old system from 11 to 16 lbs. of seed are placed by a boy in a woollen bag; the press man takes up the bag, doubles it back so as to close the mouth, and then places it on the lower half of a "hair" or other envelope (Figs. 50 and 51*)

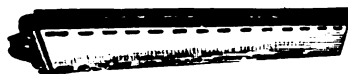

Fig. 50.

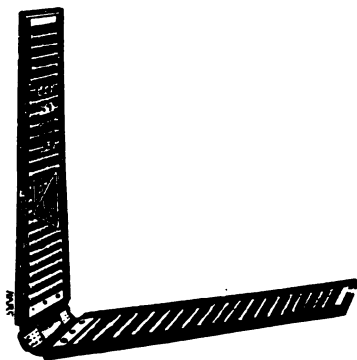

Fig. 51.

* Envelopes of vulcanised fibre, paper, and other materials are frequently employed instead of the more expensive "hairs."

that he has previously placed on a table in front of the press. He then smooths the bag with his hand until the seed is distributed throughout the interior as equally as possible. The envelope is then closed over the bag, and the whole taken up and placed in the press. This process is continued until the press is filled, each cake, together with its box, occupying a vertical thickness of upwards of 10 inches. When the moulding machine is used,

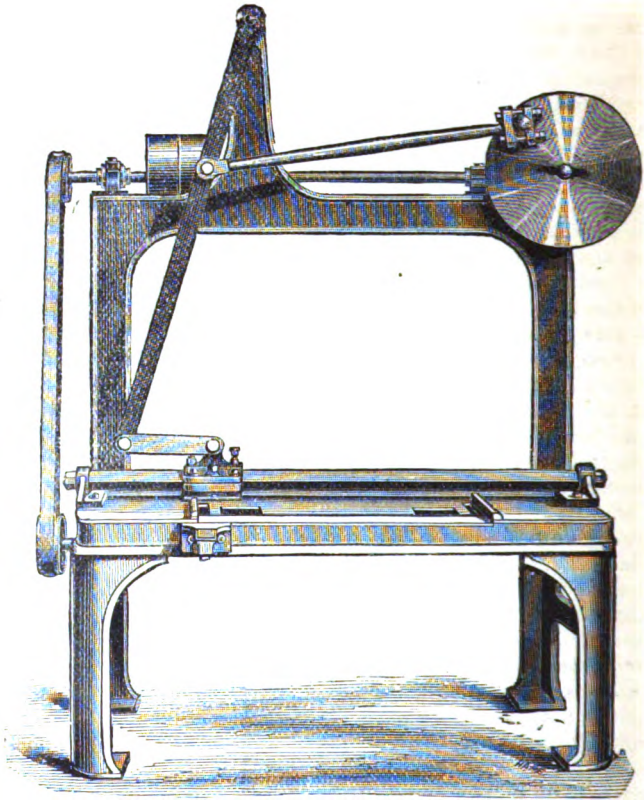

Fig. 52.

each cake with its plate only occupies 3 inches, thereby greatly increasing the capacity of the press ; whilst the cost of labour is considerably lessened. The moulding is thus effected ; the workman begins by raising a measuring frame and placing underneath it a sliding frame holding a tray with a piece of woollen cloth about double the length of the tray placed thereon centre to centre, the ends of the cloth hanging down ; the measuring frame

is now brought down on the top of the tray and cloth, and crushed seed introduced from a box (fed automatically from the kettle as required) until the frame is full. The frame is then thrown back, the loose ends of the cloth folded over the seed, and the sliding frame carrying the tray, seed, and cloth pushed forward over the pressing plate. This motion of the frame sets the machine at work, the pressing plate ascending and squeezing the seed into a compact mass about $1\frac{1}{4}$ inch thick, after remaining in contact with it about a quarter of a minute. The pressing plate then falls, and the machine stops, enabling the press man to remove the compressed cake to the press, carrying it on the tray which is withdrawn as soon as the cake is in position. During the time that the cake is being compressed, the moulder is engaged in forming another one on a tray in front of the machine as before; so that cakes to the number of 240 may be thus moulded in an hour.

Fig. 49 represents a moulding machine actuated by steam in position with respect to the kettle; other forms are sometimes used worked by hydraulic power.

Paring Machine.—The cakes obtained in the hydraulic press are usually oily at the edges where the oil exuded, so that the edges require to be cut off, not only to trim the cakes, but also to save the oil with which they are impregnated, the parings being ground up and returned to the kettle. In mills working on the older systems the press cakes are generally trimmed by hand; but the simple form of machine indicated in Fig. 52 not only enables the parers to do much more work in a given time, but also to cut the edges far more regularly and neatly. The cake to be pared is placed with one edge over a central longitudinal trough; a cutter block with attached knife passes along and shears off the portion of the cake projecting beyond a given line, being driven by the excentric working a bar jointed to the upper part of the frame. The other side and ends of the cake are trimmed in the same way, two knives being attached to the cutter block, one cutting when the motion is in one direction, the other when in the opposite direction. A screw works in the trough, so that as the parings fall they are carried onward by the screw and delivered on to the upper carfe plate of a pair of edgestones (Fig. 48), whereby they are reduced to meal, which is then taken up and distributed to the kettles by elevators and screws.

Supplementary Appliances.—In addition to the preceding principal appliances, various other minor arrangements are requisite in a well appointed oil mill. Thus, screens of various sizes of mesh are necessary in order to sift out stones, &c., and to partially separate different kinds of admixed seeds when their respective dimensions renders this practicable. Machines for decorticating seeds are also employed. Fig. 53 represents cotton seed treated by such a machine. A, ordinary Egyptian seed

coated with cotton filaments; the machine cuts through the husk and kernel, B; a separator then divides the husks, C, from

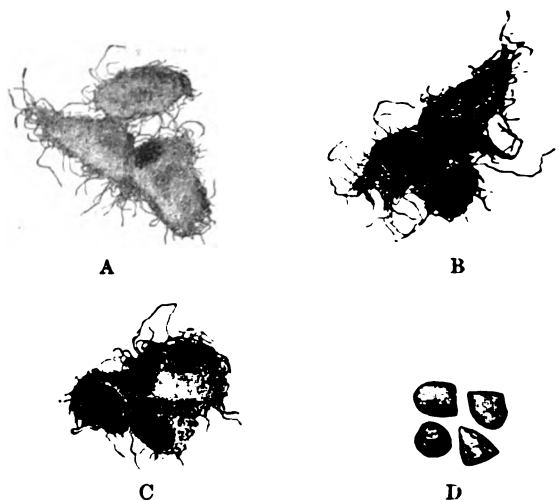

Fig. 53.

the oily kernels, D, the latter being crushed and expressed, and the former used for manure, &c. Similarly, castor beans are contained in an outer shell (Fig. 54, A); a special castor seed

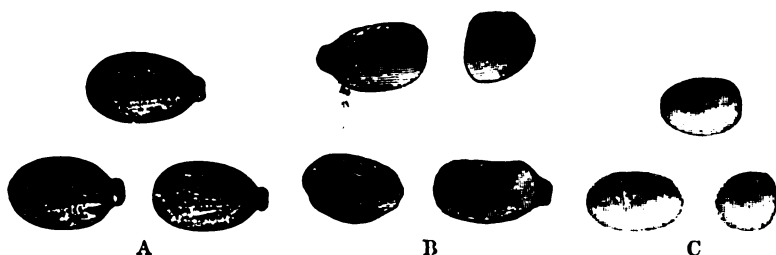

Fig. 54.

decorticating machine removes the outer shell, B, leaving the white kernel, C, ready for the press. Analogous machines are employed for decorticating arachis nuts and for splitting coker-nuts, cutting through husk, shell, and kernel at one operation; and for grinding and disintegrating coprah. Pulverising machines for this purpose, where the action is brought about by a series of blows from rapidly moving flat beaters, answer better than those where the grinding is effected between parallel iron

discs by friction. Fig. 55 illustrates the arrangement used when such a disintegrator is mounted directly over the kettle, and fed by an elevator.

Dudley & Perry have patented a process* for chemically decorticating cotton seed. The seeds, after linting, are subjected to the action of gases containing nitrous anhydride and sulphur dioxide, with enough air to "regenerate" the higher oxides of nitrogen as fast as they are reduced. After a few seconds

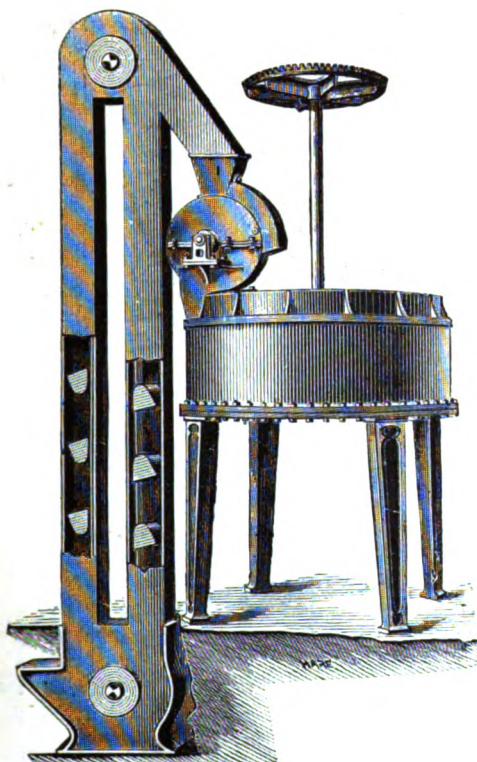

Fig. 55.

exposure the fibre has changed but little in appearance, but its structure is completely destroyed, so that the slightest friction causes it to fall to an impalpable powder, leaving the seeds perfectly smooth, and showing no signs of corrosion. A slight acid reaction is perceptible on the outside, easily removable by washing; but no acid penetrates into the interior.

* U. S. Patent 344,951.

The crude expressed oil carries with it more or less watery matter, together with mucilaginous and albuminous organic sub-

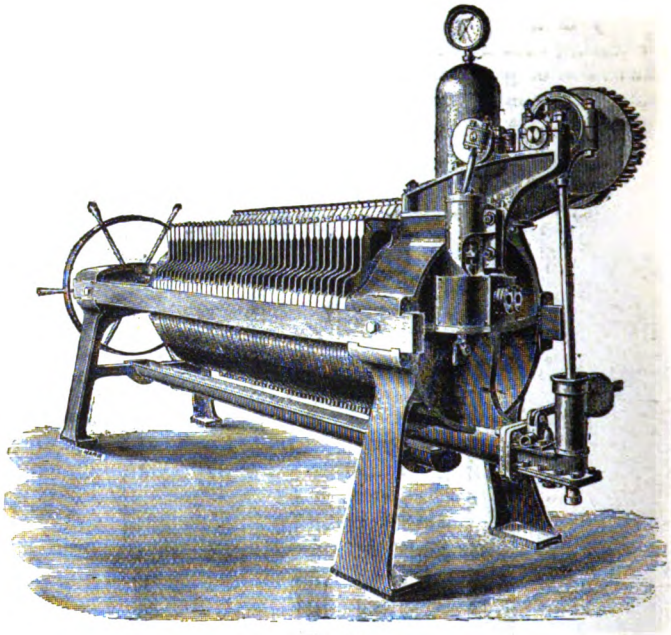

Fig. 56.

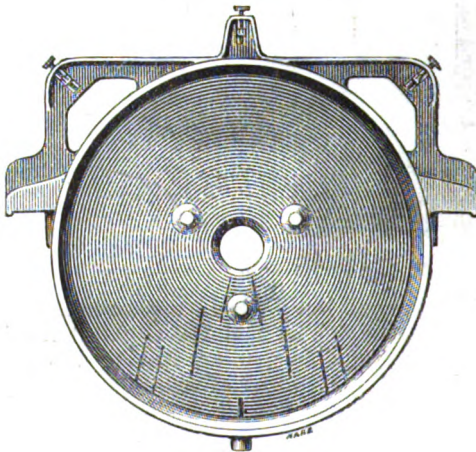

Fig. 57.



Fig. 58.

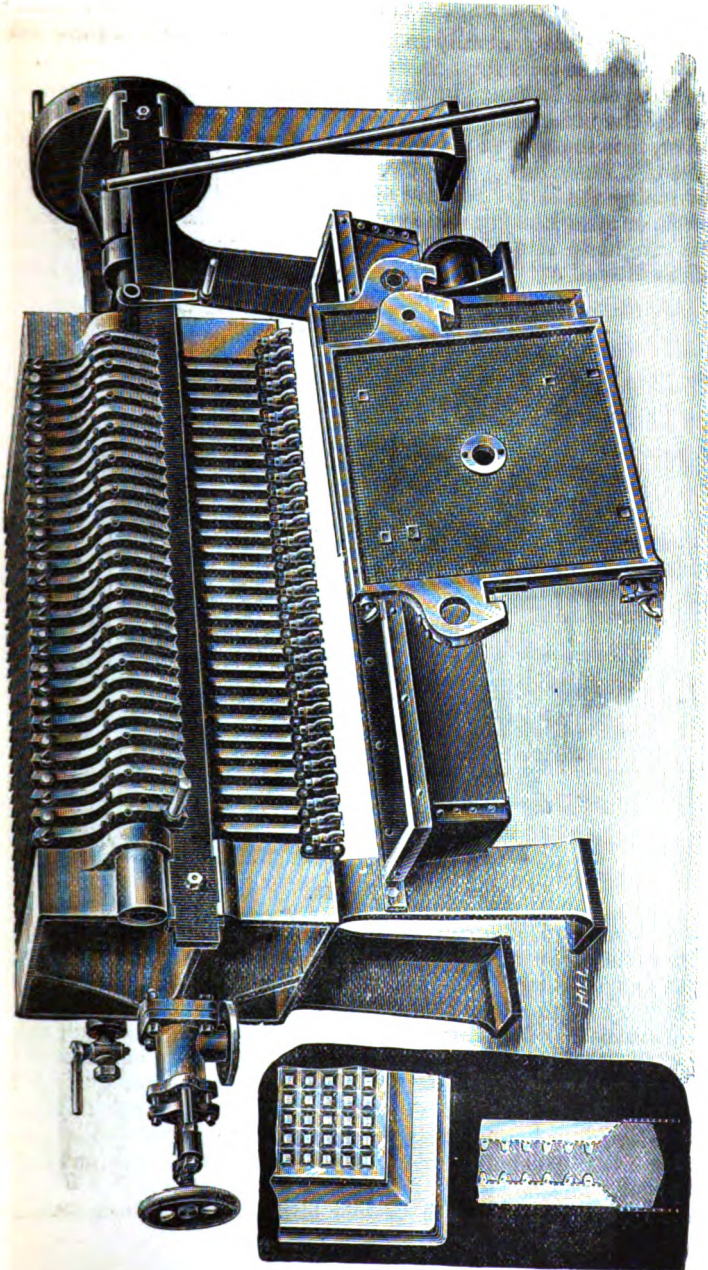

Fig. 59.

stances, requiring processes to be adopted for their removal. Formerly these generally involved long continued standing, so as to enable the solid impurities to form and settle, the process being in some cases hastened by heating to coagulate albuminous matter, or by the use of chemicals (*vide* Chap. XI.) In many cases, however, it is found that a degree of clarification sufficient to render the oils immediately saleable, can be rapidly effected by simply pumping the oil (either just as it runs from the press into the oil well, or after heating to a temperature somewhat short of 100° C. to coagulate mucilage, &c.) through a filter press; the matters thus filtered out from the oil are generally returned to the kettle

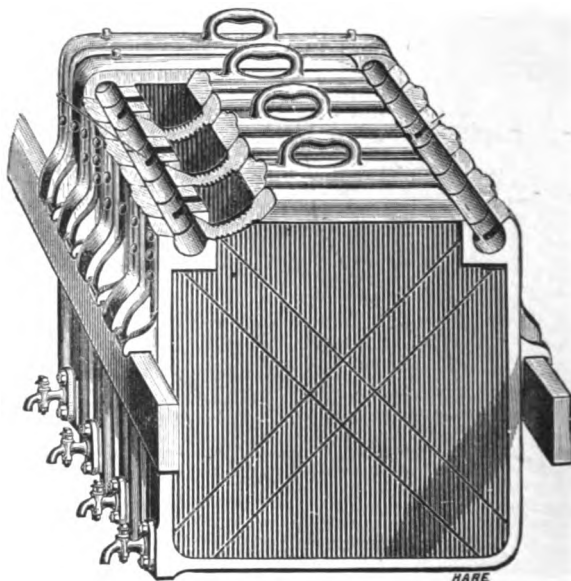

Fig. 60.

and worked over again with a fresh batch of crushed seed, so that the only products finally obtained are filtered oil and pressed cake, no "foots" of any kind being made. In the case of many kinds of oil this simple treatment suffices to refine the oil sufficiently for most purposes; in other cases, although subsequent refining methods are still requisite, yet on account of the previous removal by filtration of a large proportion of the impurities, the rest of the refining process is much facilitated and shortened. Accordingly, in the newest installations suitable filter presses form an important part of the subsidiary appliances employed.

▲ Fig. 56 represents a hydraulic filter press with self-contained

engine and pump, made by Messrs. S. H. Johnson & Co., of Stratford; the plates are "recessed," so that the raised rims of the consecutive plates enclose a space when they come together, which finally becomes filled with the solid matters taken from the material filtered. Figs. 57 and 58 represent the front elevation and sectional elevation of the plates, which are provided with adjustable tension hooks to carry the cloths, and stay boss projections so as to prevent fracture of the plates when working under high pressure, each plate supporting the next adjoining one from end to end of the machine. Figs. 59 and 60

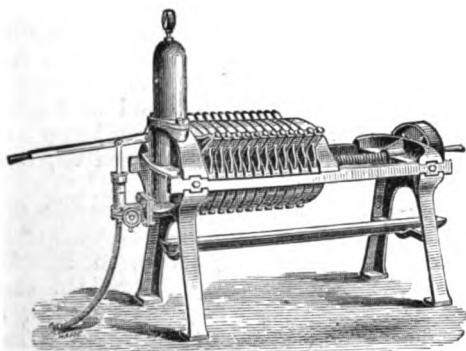

Fig. 61.

represent a different type of plate surface ("Pyramid drainage" surface), whereby washing of the cakes produced is more readily effected, and the efficiency of the press largely increased in the case of viscid liquids. Fig. 61 represents a miniature pattern of hand-worked press for small operations and experimental purposes.

SEPARATION OF SOLID STEARINES FROM OILS, &c.

Many oils when allowed to stand for some time at a sufficiently low temperature deposit more or less copious amounts of solid matter, sometimes becoming semisolid or buttery in so doing. If the temperature be raised the whole mass melts again to a fluid oil; but by "bagging" (or straining off the liquid portion through canvas bags forming rough filter-strainers) without applying heat, the solid matter may be collected; and by applying pressure to the "bagged" mass the remaining liquid may be squeezed out. When the solid matter thus collected is sufficiently granular, the ordinary method of cold pressing may be conveniently applied, the process being carried out in much the same

way as that above described in the case of crushed seed pulp, excepting that the pressure is applied more gradually and gently; but in many cases the solid particles are so fine that they are largely forced through the interstices of the press cloth (even when specially made cloths are employed) and thus lost in the liquid runnings. In cases where the solid matter is present in too small quantity for ordinary cold pressing filter presses may often be conveniently employed to collect and consolidate the solidified constituents. Thus olive oil when cooled for some time deposits a considerable fraction of the more solid glycerides contained (palmitin, stearin, arachin); these when collected by the filter press furnish an "olive stearine," whilst the filtered oil is proportionately less liable to thicken and deposit in cold weather. Similarly cotton seed oil furnishes a considerable amount of "cotton stearine" and a more fluid liquid oil, known in consequence as *winter oil*. Animal oils, such as cod liver oil and whale oil, furnish analogous stearines; from sperm oil, spermaceti is similarly separated.

In the manufacture of paraffin wax for candle making, &c., certain fractions of the distillates obtained consist of mixtures of hydrocarbons of different melting points, some fusing at considerably above the ordinary temperature. On chilling such "oils," by means of a suitable frigorific machine, the hydrocarbons of higher fusing point mostly separate in the solid form; so that by straining the magma, or subjecting it to filter pressure, the solid paraffins are separated from those yet liquid. The solid matters thus obtained (paraffin scale), when refined, redistilled, and subjected to further pressings at regulated temperatures, ultimately furnish "paraffin wax" of melting point the more elevated the higher the temperature at which the last warm pressing has been effected, this temperature being regulated by the nature of the material dealt with, some kinds of distillates furnishing paraffin wax of higher melting point than can be isolated from others.

Similar operations are gone through in various other manufactures connected with the coaltar and mineral oil industry; thus the separation of carbolic acid from mixtures of that substance and its homologues and other bodies accompanying it, is effected by chilling by means of an ether or ammonia freezing machine, and draining off the unfrozen liquid from the mass of crystals that gradually forms. Similarly "anthracene oils," obtained at a certain stage of coaltar distillation, become more or less pasty and semisolid on cooling and standing; so that by straining off the liquid portions (by filter pressing or otherwise) and subsequently expressing the remaining liquid by more powerful pressure, a solid residue is ultimately obtained, consisting of anthracene intermixed with other solid hydrocarbons, &c.

In the manufacture of "stearine" for candles (stearic and

palmitic acids, &c., p. 110), similar operations are gone through for the purpose of isolating mechanically the solid fatty acids that have crystallised into a honeycombed mass, the interstices of which are filled with the liquid acids ("red oils"). Hydraulic pressure of the spongy solid mass in sacking serves to effect a first separation of matters respectively solid and liquid at the ordinary temperature. Further "hot pressing" at a more elevated temperature brings about a more complete elimination of liquid acids from the crude once-pressed stearine; whilst by chilling the red oils, a separation of part of the solid acids dissolved in them takes place, so that by filter pressing the mass fluid red oils run through, whilst an additional quantity of impure solid acids is retained on the filter cloths.

Manufacture of Lard Oil, and Allied Products.—At the ordinary temperature of 15° to 25° C., lard constitutes a soft mass consisting of two kinds of matter, one solid and one fluid; it is, in fact, an exaggerated case of the mechanical separation from one another of two constituents of a mixture possessing different solidifying points when the temperature is maintained between the two temperatures of fusion, chiefly differing from the partial solidification of fluid oils on cooling and standing in that the solid constituent has a higher melting point, and is present in larger quantity. By placing the lard in close textured woollen bags supported by wickerwork frames, and subjecting it to long continued cold pressure (about 10 cwts. per square inch, lasting for some 18 hours), the fluid constituent is gradually expressed and the solid retained. The former is known as "lard oil," and constitutes about three-fifths of the whole; the latter is "lard stearine," and is a valuable material for the preparation of the better kinds of soaps.

Coker butter (cokernut oil kept at not too high a temperature) and other analogous vegetable semisolid oils or butters, can, in like manner, be separated by pressure into a fluid "coker oleine," and a solid "coker stearine;" and in similar fashion, the more fusible fats obtained in the first process for the manufacture of butterine, solidify at a suitable temperature to a semisolid mass, which, when carefully pressed, yields a fluid portion becoming of a buttery consistence when cooled a little further, and a solid stearine suitable for candle and soap making. Fats of greater solidity at ordinary temperatures, such as tallow, when similarly expressed, also separate into two portions—*e.g.*, liquid "tallow oil" and solid "tallow stearine."

EXTRACTION OF OIL FROM SEEDS, OIL CAKE, &c., BY SOLVENTS.

Most oily matters are extremely freely soluble in benzene, light petroleum distillate, ether, chloroform, carbon disulphide,

and other readily volatile solvents; so that by bringing such fluids in contact with the material to be treated, the oleaginous matter is dissolved, whilst the other constituents are mainly unaffected. By drawing off the solution and subjecting it to distillation the solvent is volatilised, and with proper condensing arrangements can be regained with but little loss for use over again, whilst the oil remains in the still.

A large number of different arrangements have been proposed, and many are in actual use (more especially on the Continent) for effecting this purpose, differing in various respects according to the nature of the material to be treated and the solvent employed, &c. When the material is rich in oil—*e.g.*, when palm kernels (ground to meal) are used, and similar substances not already largely deprived of oil by expression, the apparatus employed essentially consists of a cylinder or other closed tank of boiler plate, provided with a manhole for charging and discharging the meal, which is supported on a perforated false bottom. Into this carbon disulphide is run by gravitation, or pumped from a well, entering at the bottom and passing upwards through the mass (or *vice versa* when light petroleum spirit is used); the fluid dissolves out the oil, and runs away at the exit either direct to the distilling apparatus, or to another similar cylinder where it dissolves out more oil, furnishing a stronger solution. With substances less rich in oil, such as oilcakes, several cylinders are usually worked in succession, the fluid percolating through each, and ultimately yielding a largely concentrated fatty solution, much as in the methodical lixiviation apparatus employed in dissolving crude sodium carbonate from black ash in the Leblanc soda process. The supply of disulphide to the first cylinder is kept up until a sample of the issuing fluid is found to contain little or no oil in solution. The connection with the disulphide supply is cut off, and then by means of a current of compressed air or of steam, the fluid in the first cylinder is forced onwards into the second, which is then coupled to the supply, becoming the first of the series. The disulphide still adherent to the exhausted material in the first cylinder is volatilised by means of steam, let in under the false bottom (or at the top), the vapours being carried to a condensing worm, where a mixture of water and disulphide is condensed. The exhausted material is then discharged, the cylinder refilled, and coupled to the series at the far end, so that the disulphide passing in has already a considerable amount of oil in solution. In this way the nearly exhausted material is fed with fresh disulphide, whilst the newly refilled cylinder is supplied with comparatively strong solution; the liquid ultimately passing out is led away to a distilling apparatus, where the volatile disulphide is steamed off, and the residual fat finally collected.

Fig. 62 (Schädler) illustrates a set of four steam-jacketted

cylinders thus used in series. A_1, A_2, A_3, A_4 , are the four vessels so connected by pipes D_1, D_2, D_3, D_4 , that the liquid passing off at the top of each is supplied to the bottom of the next, A_1 being reckoned as next to A_4 . These connections are opened and closed as required by means of the cocks E_1, E_2, E_3, E_4 ; H_1, H_2, H_3, H_4 are pieces of glass tubing serving as gauges. B is the carbon disulphide supply pipe; by means of the two-way cocks, C_1, C_2, C_3, C_4 , fresh disulphide can be supplied to any one of the four vessels as required. N is a steam pipe from which steam is blown in to any vessel by means of the cocks O_1, O_2, O_3, O_4 , or into the jackets through the cocks P_1, P_2, P_3, P_4 . F is the saturated carbon disulphide main, the final solution flowing into it through the cocks G_1, G_2, G_3, G_4 . J is a pipe into which the liquid contents of the cylinders can be blown off through the cocks K_1, K_2, K_3, K_4 . L is a compressed air main from which air can be supplied to each cylinder by the cocks M_1, M_2, M_3, M_4 .

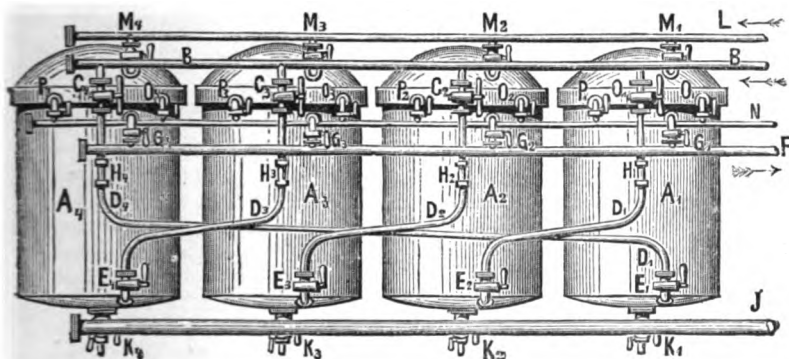

Fig. 62.

Suppose all four vessels filled with material to be exhausted; by opening the cock C_1 , connection is established between the disulphide main, B , and the cylinder A_2 , through the pipe D_1 , and cock E_2 ; disulphide then flows into A_2 , percolating through the material until the level of the cock C_2 is reached; this is set so as to shut off the disulphide main and open the connection with A_3 through D_2 and E_3 , consequently the disulphide passes onwards into A_3 . In similar fashion it passes successively into A_4 through C_3, D_3 , and E_4 , and into A_1 through C_4, D_4 , and E_1 . Finally, it is drawn off through G_1 into the saturated solution main, F , whence it flows to the still (or an intermediate store tank). The progress of the extraction is judged by the colour visible at the gauge, H_2 ; when the liquor is seen to be devoid of colour, all available oil has been dissolved. The cock C_1 is then closed so as to shut off the disulphide supply, E_2 is closed,

and M_2 and K_2 opened, so that compressed air enters A_2 and forces the liquid contents out through the discharge pipe, J ; the steam cocks O_2 , P_2 are then opened, so that the cylinder and contents are heated, the disulphide vapour thus produced being driven out along with some water vapour through J to a condensing apparatus. To avoid loss of disulphide vapours not completely condensed but carried away with the escaping air, this is made to pass through an absorbing vessel containing oil which dissolves out the disulphide, forming a liquid from which the disulphide is recovered by distillation when strong enough.

The cylinder A_2 being exhausted and all disulphide steamed off, the manhole is opened, the exhausted charge withdrawn, and a new one introduced. A_2 is then coupled on in front of A_1 and the whole operation recommenced, the order in which the fresh disulphide passes through the series being now A_3 , A_4 , A_1 , A_2 .

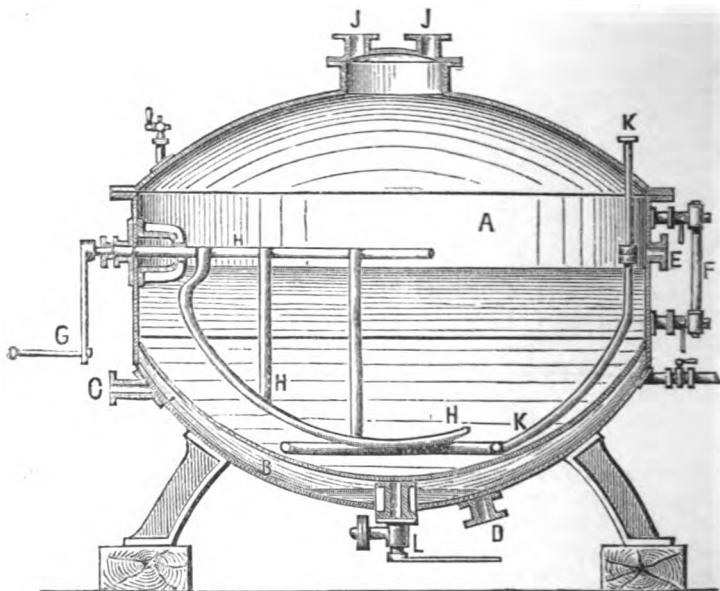

Fig. 63.

instead of A_2 , A_3 , A_4 , A_1 , as at first. In similar fashion, A_3 , A_4 and A_1 are in turn exhausted and recharged.

Fig. 63 represents a Heyl's distillation apparatus for boiling off the carbon disulphide from the fatty solution thus obtained. A is a boiler-plate vessel furnished with a steam jacket, B , at the base. Steam is let in at C , and the condensed water drawn off at D . The disulphide solution is supplied at E , the gauge F enabling the right level to be attained. L is the draw-off pipe

for the oil finally left; J J exit leading to condenser; H an agitator worked by a handle, G; K, a tube through which steam can be led in to a circular pipe at the base inside, perforated with a number of minute orifices. The solution being run in, steam is turned on when boiling soon commences, the disulphide vapours being led away through J to the condenser. The agitator, H, facilitates the evaporation; at the end steam is blown in through K, so as to pass through the residual oil in a multitude of fine streams, and so drive off the last traces of disulphide vapour. Finally, the oil is drawn off through L, and a fresh charge introduced.

Fig. 64 represents a simpler form of extraction apparatus (Deitz's), consisting of an extraction tank, B, into which disulphide is pumped at the bottom from the well, A, by the pipe, *h*, the fatty solution passing off at the top through the pipe, *f*, to the still, D; the vapours here evolved are led away through the pipe, *ee*, and condensed by the worm, C, the condensed disulphide returning to the well, A. When the extraction is complete, the disulphide supply is shut off and steam injected into B through a coil at the base below the false bottom, *dd*;

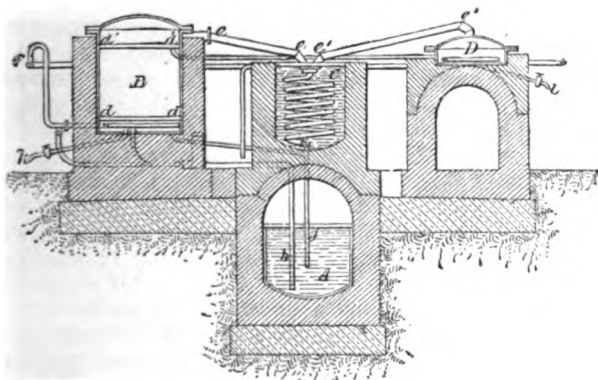

Fig. 64.

the residual fluid in B is thus forced back into A, and as the heat becomes greater, the disulphide still remaining in the exhausted mass is volatilised and carried to the worm, C, through the pipe, *ee*. The heat is supplied to the still, D, by means of a steam coil inside; finally, steam is blown through the residual oil to remove the last traces of disulphide, and the oil drawn off through the discharge pipe, *i*. A series of these extractors is generally employed, worked in couples alternately.

Carbon disulphide being heavier than water is comparatively readily protected from evaporation by a layer of that fluid on its surface; on the other hand, its vapour is very readily

inflammable, and when breathed for long periods produces a peculiar form of poisonous action, culminating in a species of insanity. Light petroleum spirit is cheaper, but, owing to its being lighter than water, cannot be so well protected from evaporation and consequent danger of fire and of explosion when a mixture of its vapour and air is ignited; moreover, its solvent action is less rapid. The former solvent is more generally used in Europe, the latter in America. Grills & Schröder have patented the use of *liquefied sulphur dioxide* at 30° to 40° C. under a pressure of some six atmospheres as a solvent for oils for extraction purposes (Patent No. 19,948, Dec. 11, 1889); and Lever & Scott have similarly patented the use of *carbon tetrachloride*, which is said to yield a purer product than carbon disulphide (Patent No. 18,988, Nov. 26, 1889).

Extraction of Grease from Engine Waste, &c.—The greasy cotton waste, rags, &c., that accumulate where machinery is largely used from the wiping of spindles and cleansing of metal work, &c., and similar materials are sometimes treated with solvents for the purpose of recovering the oily matter, after which the material is more or less cleansed by boiling with alkalies, &c., and washing, so as either to be capable of use over again or to be suitable for paper making. The plant used for this purpose differs little from that above described. An old boiler or some similar vessel is erected, a false bottom or grating supplied at the base, and suitable manholes. The solvent liquid is run in (from the base, if carbon disulphide, because that liquid becomes lighter by dissolving fatty matters; from the top, if light petroleum spirit, for the opposite reason), so as to percolate through the greasy rags, &c., the solution obtained being distilled so as to recover the solvent and separate the grease. Owing to the prevalent use of hydrocarbons in preparing lubricating oils, the grease thus obtained is rarely available for soap making, except when largely admixed with other fatty materials.

Fig. 65 represents an arrangement used in Lancashire for the purpose of cleansing engine waste, and recovering grease therefrom. It consists of a vessel of boiler plate, about 9 feet high and 6 diameter, with a grating, F, forming a false bottom, and a gooseneck leading to a worm condenser, C; G is a pipe supplying steam, and E a cock for withdrawing grease. The grating, F, is fixed about 2 feet above the bottom, and consists of a disc of $\frac{1}{2}$ -inch boiler plate pierced with numerous slightly conical holes, $1\frac{1}{2}$ inch diameter on the upper side, 1 inch diameter on the under side. Some 3 tons of greasy waste are shovelled in through the upper manhole, A. Coal-tar benzene, boiling not higher than 100° C., or benzoline (light petroleum distillate) is then pumped in through A, and percolating through the mass dissolves out grease, accumulating under the false bottom. A is then closed and made vapour tight with lime paste.

Steam is then blown in through the pipe, G; the vapours evolved at first become condensed in the comparatively cool mass of waste above, and thus serve to wash out the remaining greasy solution adhering thereto; by and bye the vapours pass over into the condensing worm, C, made of 2 to 3-inch leaden or iron piping, arranged so as to form 10 to 12 turns 6 feet in diameter; a plentiful supply of cold water is admitted at the base of the cistern in which the worm is set, passing off by an overflow pipe at the top. Finally, when all volatile matters are expelled from the still, and nothing but water is condensed in the worm, the steam is shut off, and the waste extracted through the lower manhole, B. To complete the cleansing it is boiled in a kier with soda, washed plentifully with water in a dash-wheel, soaked in dilute hydrochloric acid to dissolve out oxide of iron, again

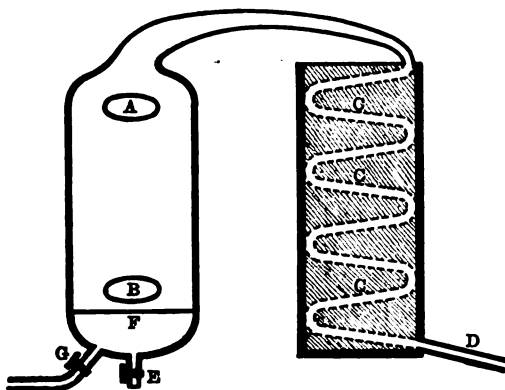

Fig. 65.

washed in the dash-wheel, drained in a centrifugal machine, and hung up to dry. From 50 to 60 per cent. of cleansed waste is usually thus obtained from the greasy raw material.

The recovered benzene runs along with the condensed water through D to a covered cistern (conveniently an old boiler), where the two separate by gravitation; the lighter hydrocarbon is pumped up again into the extraction vessel for a new charge, whilst the water is run away from time to time as it accumulates, by means of a cock at the bottom of the cistern. The grease thus recovered is generally too impure to be used directly for anything but cart grease or other coarse lubricating purposes. By distillation with superheated steam, it may be partially purified and rendered serviceable for various other purposes.

Somewhat similar methods are in use for the extraction of "woolfat" from raw wool (*vide* Chap. *14*, *lanolin*).

Determination of Fat in Seeds, &c.—When it is required to determine analytically the amount of oleaginous matter

present in a solid substance chiefly containing non-fatty constituents (*e.g.*, crushed seeds or oilcake, the residue left on evaporating milk or cream, and such like materials), the process adopted is substantially an application on the small scale of the general principles involved in the large-scale extraction methods above described. When the fatty matter predominates, the weighed portion of substance is stirred up with ether, chloroform, light petroleum spirit, carbon disulphide, or other convenient solvent, and the whole poured into a weighed paper filter, the undissolved matters being thoroughly washed out, and examined as found requisite after drying and weighing (p. 123). When, however, the fatty constituents are in the minority, the process is slightly modified: the coarsely powdered material is placed inside a piece of glass tubing, the lower part of which is constricted and blocked with cotton wool, glass wool, or asbestos fibres, &c., so as to form a strainer; the solvent is poured into the tube, percolates slowly through the pulverised material, and passes out at the lower end (filtered clear by the cotton wool) into a vessel placed to receive it, the dissolved fatty matters being obtained in weighable form by evaporating off the solvent.

Solution of fatty matter takes place more rapidly under such circumstances if the solvent be warm; to effect this, as well as to economise labour and solvent, various devices are in use,

essentially modifications of the arrangement described by Soxhlet, and generally known as "Soxhlet's tube." Fig. 66 represents one of the earliest forms, and Fig. 67 an improved form, less fragile. The substance to be exhausted is placed in the wider tube, A (Fig. 66), the lower part of which is stopped with a loose plug of cotton wool, &c., or it is wrapped in filter paper so as to form a cylindrical package, fitting loosely into A. No connection subsists between the interior of B and A except through the side pipe, C. The lower end of B is made to pass through a perforated cork into a weighed flask; the upper end of A is similarly connected with a reflux condenser, preferably of Allihn's form, Fig. 68. A suitable quantity of solvent being placed in the flask, on heating this (by a waterbath, &c.) the liquid is vapourised, and passes upwards

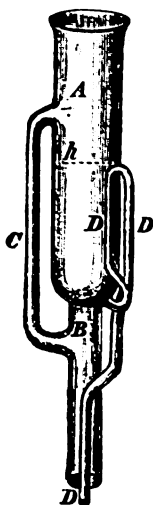

Fig. 66.



Fig. 67.

through B and C, to the condenser; the condensed fluid drops

down into A on to the substance to be exhausted; when the fatty solution accumulates to the level, *h*, the siphon, D D D, begins to act, and draws off the fluid into the flask. After some 20 or 30 siphonings, all trace of fatty matter is dissolved out; by disconnecting the flask, and evaporating off the remaining

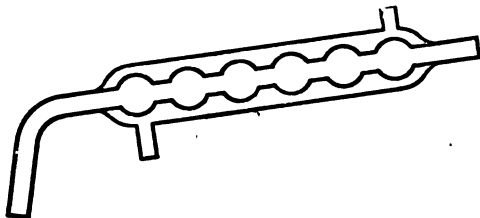

Fig. 68.

solvent, the dissolved oil is obtained. In this way the solution is effected by means of solvent appreciably warmed by contact with the hot vapour in the upper part of A, whilst the operation goes on automatically.

Figs. 69 and 70 represent an improved form of Soxhlet tube, arranged by R. Frühling;* the substance to be examined is placed in the vessel A, Fig. 69, provided with an internal siphon; this, when weighed, is placed inside the Soxhlet reservoir, Fig. 70, connected at the top with the lower end of the reflux condenser, C, and at the bottom, *b*, with the flask for receiving the fatty solution. The weight of substance left after removal of oil can thus be determined by simply reweighing A.

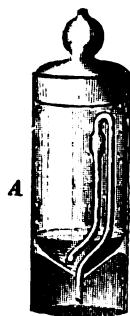

Fig. 69.

Many other forms of extraction apparatus have been devised and recommended by various experimenters for the quantitative determination of butter fat in milk residues, and such like purposes.

Fig. 71 represents a convenient arrangement on the principle of Soxhlet's tube for the laboratory extraction of oleaginous matter from somewhat larger quantities of material.

Fig. 72 represents a modification useful for extracting unsaponifiable matters from liquids—*e.g.*, the alcoholic soap solutions obtained by saponifying oils with alcoholic potash. The liquid is placed in the extraction vessel, A, which contains a number of glass beads; the condensed solvent (light petroleum spirit) drops into the funnel, B, rises up between the beads, washing out soluble matters from the liquid, and overflows into the distillation flask, E, down the side tube, *h*.†

* *Zeitschrift für angewandte Chemie*, 1889, p. 242.

† Hcnig & Spitz, *Journ. Soc. Chem. Ind.*, 1891, p. 1039; from *Zeitsch. f. angew. Chemie*, 1891, 19, p. 565.

Some kinds of seeds contain a notable proportion of substances soluble in ether, other than fatty matters—*e.g.*, phytosterol (p. 17) and lecithin (or a mixture of lecithins); the latter, con-

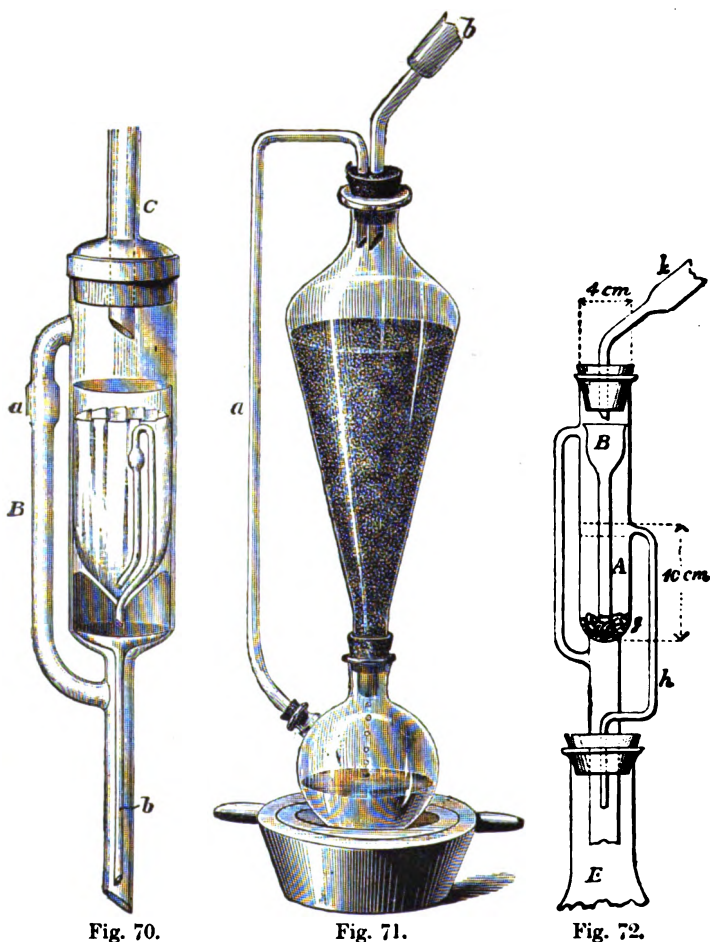

Fig. 70.

Fig. 71.

Fig. 72.

taining phosphorus, may be estimated by determining the quantity of that element contained in the ether extract (p. 124).

The following table is abbreviated from a larger one given by Schädler,* representing the usual proportions of total oily or fatty matter yielded by seeds, nuts, &c., of various kinds on extraction by solvents:—

* *Untersuchungen der Fette Oele und Wacharten*, 1889, p. 4.

Name of Oil, &c.	Botanical Name of Plant.	Native Country.	Percentage Yield of Oil.
Almond,	<i>Amygdalus communis</i> , L.,	Mediterranean.	48 to 50
Arachis { earthenut, peanut, } { or groundnut, } Arachis	<i>Arachis hypogaea</i> , L.,	India, Western Africa.	43 to 45 (50)
Areca nut (cabbage palm),	<i>Areca catechu</i> , L.,	East Indies.	14 to 16
Belladonna seeds,	<i>Atropa belladonna</i> , L.,	Europe.	27 to 28
Bassia fat (Illipé butter),	<i>Bassia butyracea</i> ; <i>B. latifolia</i> ; <i>B. longifolia</i> ; { <i>B. Parkii</i> ,	Himalaya and East Indies.	49 to 55
Brazil nut,	<i>Bertholletia excelsa</i> , Humb.,	South America.	66 to 67
Beechnut,	<i>Fagus sylvatica</i> , L.,	Europe.	{ Shelled, 43 to 45 { Unshelled, 27 to 29
Ben,	<i>Moringa oleifera</i> , Lamark,	India, Egypt.	35 to 36
Cacao butter,	<i>Theobroma cacao</i> , L.,	Central America.	44 to 47
Camelina see (German sesamé),	<i>Camelina sativa</i> , L.,	Europe.	31 to 34
Castor,	<i>Ricinus communis</i> , L.,	East Indies.	{ American, 46 to 49 { Indian, 51 to 53
Cokernut,	<i>Cocos nucifera</i> , L.,	Tropics.	40 to 45
Colocynth (bitter apple),	<i>Citrullus colocynthis</i> , L.,	India, Arabia.	18 to 20
Colza (rape),	<i>Brassica campestris</i> ; <i>B. napus</i> ; <i>B. rapa</i> ; { <i>B. napobrassica</i> , L.,	Europe.	33 to 43
Cotton seed,	<i>Gossypium herbaceum</i> , L.,	Asia, Africa, America.	24 to 26
Croton,	<i>Croton tiglium</i> , L.,	East Indies.	Shelled, 53 to 56
Cucumber seed,	<i>Cucumis sativus</i> , L.,	East Indies.	25 to 26
Cress seed,	<i>Lepidium sativum</i> , L.,	Europe.	23 to 25
Calabar bean (Poon seed),	<i>Calophyllum calaba</i> , Wild,	Antilles, India.	60 to 65
Cashew nuts,	<i>Anacardium occidentale</i> , L.,	West Indies, Brazil.	40 to 45
Charlock seed,	<i>Sinapis arvensis</i> , L.,	Europe.	31 to 33
Candle nuts (Bankul nuts),	<i>Aleurites moluccana</i> , Wild,	Southsea Islands.	62 to 64

Name of Oil, &c.	Botanical Name of Plant.	Name of Country.	Percentage Yield of Oil.
Crabwood nuts (Carapa nuts),	<i>Carapa guyanensis</i> , Aubl.,	Guliana, Brazil.	65 to 70
Centaury,	<i>Centaurea sonchifolia</i> , L.,	Western Europe.	27 to 28
Chironji,	<i>Buchanania latifolia</i> , W. A.,	Malabar.	40 to 45
Combo nuts,	<i>Myristica gabonensis</i> , Aubr.,	West Africa.	60 to 64
Chaulmoogra,	<i>Gynocardia odorata</i> , K. Br.,	East Indies.	30 to 32
Corn poppy,	<i>Papaver rhæas</i> , L.,	Europe.	61 to 65
Castanha nuts,	<i>Telfairia pedata</i> , Hook,	Africa, Madagascar.	33 to 35
Chinese tallow,	<i>Stillingia sebifera</i> , Juss,	China, Punjab.	37 to 39
Dika fat,	<i>Mangifera gabonensis</i> , Aubr.,	West Africa.	60 to 64
Fever nuts (Borneo tallow),	<i>Hopea splendida</i> ; <i>H. macrophylla</i> , Vris,	Sunda Island.	45 to 50
Galam butter (Shea butter),	<i>Bassia Parkii</i> , D. C.,	Tropical West Africa.	49 to 52
Gamboge,	<i>Garcinia pictoria</i> , Roxb.,	India.	24 to 25
Grape seed,	<i>Vitis vinifera</i> , L.,	Asia.	11 to 12
Goa butter (Kokum fat),	<i>Garcinia indica</i> , Chois,	East Indies.	22 to 25
Hazel nut,	<i>Corylus avellana</i> , L.,	Europe.	50 to 60
Hemp seed,	<i>Cannabis sativa</i> , L.,	Asia.	30 to 35
Hickory nut,	<i>Carya amara</i> , C. alba, Mich.,	North America.	29 to 30
Henbane seed,	<i>Hyoscyamus niger</i> , L.,	Europe.	35 to 37
Horned poppy seed,	<i>Glaucium luteum</i> , L.,	Middle Europe.	30 to 35
Horse chestnut,	<i>Æsculus hippocastanum</i> , L.,	Perisia, India.	6 to 8
Holly seed,	<i>Ilex aquifolium</i> , L.,	Europe.	25 to 27
Indian butter (Fulwa butter),	<i>Bassia butyracea</i> , Roxb.,	Himalaya.	50 to 52
Indian cress seed,	<i>Tropæolum majus</i> , L.,	South America.	46 to 50
Java almond,	<i>Bursera paniculata</i> , Lam.,	Molucca.	40 to 42
Japanese wax,	<i>Rhus succedanea</i> , L.,	China, Japan.	22 to 23
Karanja butter (Ponga butter),	<i>Pongamia glabra</i> , Vent.,	India.	34 to 36
Lallemantia,	<i>Lallemantia iberica</i> , Fisch. and M.,	Perisia and Kurdistan.	29 to 30

Name of Oil, &c.	Botanical Name of Plant.	Native Country.	Percentage Yield of Oil.
Lettuce seed,	<i>Lactuca oleifera</i> , L.,	Europe.	37 to 33
Laurel butter,	<i>Laurus nobilis</i> , L.,	South Europe.	24 to 26
Linseed,	<i>Linum usitatissimum</i> , L.,	The East.	38 to 40
Lindon seed,	<i>Tilia macrophylla</i> , L.,	Europe.	25 to 28
Mahwa butter (Illipé butter),	<i>Bassia latifolia</i> , Roxb.,	East Indies.	50 to 55
Maize,	<i>Zea mais</i> , L.,	America.	6 to 10
Macaja butter,	<i>Cocos aculeata</i> , Jacq.,	Brazil, West India.	60 to 65
Madia,	<i>Madia sativa</i> , Molin.,	Chili.	32 to 33
Matara tallow,	<i>Matuereira olifera</i> , Pect.,	Mozambique.	60 to 65
Mustard seed (white),	<i>Sinapis alba</i> , L.,	Europe.	25 to 26
" (black),	<i>Sinapis nigra</i> , L.,	Europe.	31 to 33
Nettle seeds,	<i>Urtica dioica</i> , L.,	Europe.	30 to 32
Nut (walnut),	<i>Juglans regia</i> , L.,	Persia, Himalaya.	63 to 65
Nutmeg,	<i>Myristica moschata</i> , Thunb.,	Molucca.	38 to 40
Niger (Kantil),	<i>Guizotia oleifera</i> , D.C.,	Abyssinia, India.	40 to 45
Nightsshade seed,	<i>Atropa belladonna</i> , L.,	Europe.	27 to 28
Olive,	<i>Olea europæa</i> , L.,	Southern Europe.	{ Pericarp, 40 to 60 { Kernels, 12 to 15
Otoba,	<i>Myristica otoba</i> , Humb. and B.,	Columbia.	35 to 40
Ocuba wax,	<i>Myristica ocuba</i> , Humb. and B.,	Brazil.	20 to 25
Peach kernel,	<i>Prunus persica</i> , Benth.,	Persia.	46 to 48
Palm,	<i>Elais guineensis</i> , Jacq.,	West Africa.	{ Pericarp, 65 to 72 { Kernels, 45 to 50
Poppy seed,	<i>E. melanococca</i> , Gaert.,	South America.	{ Blue, 48 to 50 { White, 41 to 45
Pumpkin seed,	<i>Papaver somniferum</i> , L.,	Asia Minor.	20 to 25
	<i>Cucurbita pepo</i> , L.,	The East.	

Name of Oil, &c.	Botanical Name of Plant.	Name of Country.	Percentage Yield of Oil.
Piney tallow (Malabar tallow)	<i>Vateria indica</i> , L.	East Indies.	...
Pistachio nut,	<i>Pistacia vera</i> , L.	South Europe.	51 to 53
Purgir nut,	<i>Caracas purgaus</i> , Endl.	West Indies, S. America.	Shelled, 55 to 57
Radish seed,	<i>Raphanus sativus oleiferus</i> , L.	China.	45 to 50
Red pine seed,	<i>Pinus abies</i> , L.	Europe.	25 to 30
Safflower seed,	<i>Carthamus tinctorius</i> , L.	Egypt, India.	30 to 32
Scotch fir seeds,	<i>Pinus sylvestris</i> , L.	North Europe.	28 to 30
Sesamé (gingelly),	<i>Sesamum indicum</i> ; <i>S. orientale</i> , L.	India, Levant, Antilles, &c.	50 to 57
Spurge,	<i>Euphorbia lathyris</i> , L.	South Europe.	43 to 46
Soap berry,	<i>Sapindus emarginatus</i> , Roxb.	India.	30 to 32
Sierra Leone butter,	<i>Pendadesma butyracea</i> , Don.	Sierra Leone.	59 to 62
Sunflower seed,	<i>Helianthus annuus</i> , L.	Mexico, Peru.	21 to 22
Spindle nut,	<i>Eunonymus europæus</i> , L.	Middle Europe.	44 to 45
Spruce fir seed,	<i>Datura stramonium</i> , L.	Europe.	25 to 27
Sapucaja nuts,	<i>Pinus picea</i> , L.	Europe.	32 to 33
Spring poppy seed,	<i>Lecythis ollaria</i> , L.	Brazil, Guiana.	40 to 43
Tangkaklak fat,	<i>Argemone mexicana</i> , L.	Mexico, West Indies.	25 to 30
Tea seeds,	<i>Cyclocodaphne sebifera</i> , Bl.	Java.	40 to 45
Tobacco seed,	<i>Camellia oleifera</i> , Ab.	China.	43 to 45
Thistle,	<i>Nicotiana tabacum</i> ; <i>N. rustica</i> , L.	America.	38 to 40
Ungnadia,	<i>Onopordon acanthium</i> , L.	Europe.	30 to 35
Weld seed,	<i>Ungnadia spectiosa</i> , Endl.	Mexico.	9 to 10
Water melon seed,	<i>Reseda luteola</i> .	Middle Europe.	30 to 32
Wild radish seed,	<i>Cucurbita citrullus</i> , Wgt.	Africa.	30 to 32
	<i>Raphanus raphanistrum</i> , L.	Europe.	35 to 40

CHAPTER X.

ANIMAL FATTY TISSUE : EXTRACTION OF OILS AND FATS THEREFROM.

THE "adipose tissue" (ordinarily known as "fat") of the higher animals varies considerably in consistence in different cases, but uniformly consists of a cellular or honeycomb-like structure of nitrogenous non-fatty matter, the interstices of which are more or less filled with the true non-nitrogenous fatty material; hence mechanical or chemical processes are requisite to separate the two, just as in the case of vegetable oil-containing seeds, &c. In some cases the melting point of the animal fat or oil is so low that processes of expression are applicable at the ordinary temperature, as in the case of certain fish livers (cod liver oil, &c.); either the fresh organ being used, or livers that have been stored until partial decomposition has set in, more or less rupturing the oil cells. In other cases, the temperature requires to be raised in order that the fatty matter may become sufficiently fluid to exude, as in the "rendering" of tallow and lard; for this purpose the adipose tissue may either be subjected alone to heat, or may be steamed or boiled with water at the ordinary pressure or in digesters, or may be treated with hot or cold solvents for the fat, or with substances acting chemically on the nitrogenous matter of the cell-walls, and thus tending to liberate the fat. When the nitrogenous matter is required to be saved in a solid form for manure making, the manufacture of dog-biscuit, pig feeding, or other purposes according to its quality, the first method may be employed, care being taken to prevent burning by overheating if free fire is used; or the fatty tissue may be heated in a closed vessel by means of steam and a minimum of water; or it may be minced fine and placed on sloping trays in a chamber heated by steam, so that the fatty matter gradually runs away from the solid nitrogenous cellular tissue. If, on the other hand, the saving of the nitrogenous matter in the solid form is of no consequence, the comminuted fat may be heated for some time with water in a digester under 4 or 5 atmospheres pressure; by this means a considerable proportion of the nitrogenous tissue is gelatinised and dissolved as a sort of glue, utilised either as such or for manure making. In extracting fat from bones this process is generally employed; on the other hand, when the carcasses of slaughtered horses, &c., are treated, long continued boiling in open pans under ordinary

pressure is more usually adopted, the fat being skimmed off from time to time as it rises. Sometimes a small quantity of soda, or of sulphuric acid, is added to the water with which rough fats are boiled, with the object of attacking the cell walls, and liberating the fatty matter more rapidly. A certain amount of loss by saponification takes place when soda is thus used (unless the impure soap formed is collected and utilised); whilst hydrolysis of glycerides (p. 7) is apt to be brought about by the action of acid, so that the resulting fat contains free fatty acids interfering with its use for certain purposes—*e.g.*, the manufacture of some kinds of lubricants. In the Mège-Mouries process for preparing oleomargarine of best quality (*vide* Chap. XIV.), a sort of artificial digestion of the nitrogenous matter is brought about, chopped suet being warmed with minced sheep's stomachs and a little potassium carbonate, so as to peptonise the albuminoids of the tissue and liberate the fatty matter; a much purer product is thus obtained, owing to the comparatively low temperature employed (about 45° C.) than is possible with any boiling process.

Rendering of Fatty Tissues by Dry Fusion.—When rough fats from the ox, sheep, pig, &c., are minced fine and gently heated, the melted grease gradually runs away from the solid cellular tissue. In the manufacture of butter substitutes (oleomargarine) finely chopped beef suet is sometimes thus heated to a temperature only just sufficient to partially fuse the fatty matter, and the runnings subsequently treated so as to separate the mass into a solid stearine, and a buttery mass largely consisting of oleine. Owing to the low temperature employed, 50° to 55° C., noxious vapours are not evolved at all during the process, especially as none but the freshest fatty matter is used, any admixture of slightly tainted material greatly depreciating the value of the product.

When higher temperatures (above 100° C.) are used, the rough fats being heated over a free fire with continual stirring, the moisture present is evaporated, and the nitrogenous tissue gradually dries up and shrivels; the oil cells are thus ruptured, and the melted fat escapes. The heat usually causes a considerable amount of decomposition of the tissue, leading to the evolution of most atrocious smells, especially if the fatty tissue is stale, tainted, or partly decomposed. By straining off the melted fat, and pressing the residual "greaves" or "cracklings," in such a press as is indicated by Figs. 34, 38, or 39 (pp. 202, 205, 206), the majority of the fat present is extracted; if the cracklings are intended as food (for dogs or pigs) the presence of a little residual fat therein is an improvement rather than otherwise; if required, a further amount of grease can be extracted by boiling with dilute sulphuric acid, or heating in a pressure vessel, so as partly to gelatinise the solid animal matter and liberate the remaining fat.

An improved dry heat rendering arrangement has been patented by Merryweather & Sons, in which the materials to be rendered are placed in a steam jacketed pan into the jacket of which superheated steam is passed, so that the danger of "burning" the fat is greatly lessened, whilst the heat can be much more easily regulated; accidents from fire through the pan contents suddenly foaming over can be minimised, whilst fuel is economised, and the wear and tear of the pan lessened.

The blubbers of the whale, seal, dugong, porpoise, and other cetacea, and the livers of the shark, cod, dogfish, kulp, and other fish, are generally allowed to remain in baskets or other perforated vessels at the ordinary temperature for some time, so that a first running of purer oil may be obtained spontaneously; later on heat is applied to facilitate the extraction. Formerly "boiling down" whale blubber for train oil was an operation performed on the whaling vessel shortly after the capture of the animal; at the present day the blubber is more frequently brought ashore (either to port or to fishing stations for the purpose) for treatment. A certain amount of oil is generally collected by the simple process of placing the cut up mass in racks, from which the oil drips gradually into casks; later on decomposition commences, and the oil then exuding is inferior in quality. Finally, the remaining mass is "boiled"—i.e., subjected to dry heat to extract the remaining oil. In some cases wet steam heating (*infra*) is applied at first, whereby the process is much shortened.

In order to mitigate the nuisance arising from the emanation of foul smelling vapours during the dry process for rendering fats, &c., various contrivances have been tried from time to time, such as passing the evolved vapours through layers of charcoal or through scrubbers containing alkaline or acid solutions, &c.; the only really effective method, however, depends on the destruction by combustion of the malodorous emanations, the fumes and vapours evolved being collected by a hood or pipe and made to traverse the fireplace of one of the works' boilers; or otherwise similarly consumed. Preferably the vessels are enclosed in a sort of casing, so that the vapours evolved are led away by means of a pipe to the spot where they are consumed, an indraught being maintained by means of a fan or steam jet.

Rendering of Fatty Tissues by Heating with Water or Steam under ordinary Atmospheric Pressure.—The extraction of fatty matter from adipose tissue is often greatly facilitated by mincing the tissue fine, or crushing it between rollers, and then placing it in a pan with water, the temperature of which can be raised as required, either by injecting wet steam, employing a dry steam coil or steam jacket, or by means of free fire, &c. For the preparation of oleomargarine a process of this description is often used as the first stage, selected fresh fat of

highest quality being chosen, and the temperature being kept as low as possible, consistent with the melting out of the more fusible constituents which rise to the top and are skimmed off. Latterly, a higher temperature is used, whereby a more solid fat (when cold) is obtained; and, finally, the heat is raised to 100° to extract the last portions of fatty matter. This, however, is rarely completely effected unless either a higher temperature (under pressure) is applied so as largely to gelatinise the nitrogenous tissue, or sulphuric acid is added so as to break up the fat cells by its solvent action on the nitrogenous matter. In the extraction of fat from bones boiling in open pans for some twenty-four hours with simple water is often employed, the bones being broken up into lumps so as to expose the fat cells as much as possible; the fat is skimmed off as it rises, and the liquor utilised for the preparation of size; a larger yield of fat, however, is obtained when high pressure vessels are employed (*vide infra*, p. 251).

Various fish oils are extracted by similar processes; thus, in the preparation of cod liver oil, the fresh healthy livers are first placed in open barrels, so that a certain proportion of oil spontaneously exudes; after a while they are transferred to metal pans, heated gluepot fashion in a larger external hot water vessel, or by a steam jacket; here a further separation of oil ensues, of second quality. Finally, the livers are boiled with water, when a still lower grade separates. According to the temperature employed in the first heating, the quality of the second runnings varies; when 40° to 50° C. is not exceeded, a much finer oil is obtained than when 75° to 80° is reached, more nearly approximating to the first runnings ("cold drawn" oil), but possessing a more marked brownish yellow tinge. Oil extracted by boiling with water is usually of a more or less deep brown hue.

According to P. Möller, of Christiania,* the fishy unpleasant flavour of cod liver oil is largely due to the absorption of oxygen during its extraction, and may consequently be to a considerable extent avoided by rendering the livers in vessels from which all atmospheric air is excluded by means of a current of indifferent gas, such as hydrogen or carbon dioxide.

Several species of fish of the herring and sardine class are employed in different countries as sources of oil, the simplest method of procedure adopted being to slice and mash the fish, and pour boiling water over the mass, which is then stored in barrels, &c., for some time; decomposition sets in, and the fat tissues become disintegrated, so that the oil floats up and is skimmed off at intervals. A more systematic method, adopted in the case of menhaden oil and other fish oils extracted by means of modernised appliances, consists in thoroughly boiling

* English patent, No. 13,803, 1890.

or steaming the fish (whole and unbroken, or sliced and mashed), and then subjecting to comparatively gentle pressure; the first runnings thus obtained are considerably superior to the second grade, prepared by boiling or steaming the residue a second time, and pressing again with stronger pressure, and at a higher temperature; the screw press heated by steam, shown in Fig. 38, p. 205, is well adapted for this process. The ultimate residue is utilised for manure: after being squeezed as dry as possible, preferably by hydraulic pressure, the residual solid mass is broken up and allowed to ferment, dried somewhat, ground and sifted, and finally dried further, so as to form a powder convenient for transport. Large quantities of fish manure are thus prepared from the residues of the extraction of oil from the "menhaden" or "porgie" at numerous places along the North American Atlantic coast.

D'Arcet's sulphuric acid process for rendering tallow consists in melting the adipose tissue with from one fifth to half its weight of water, and a few per cents. of sulphuric acid, keeping the entire mass boiling until the separation of fat is completed, the heat being applied by means of a free fire, by a steam jacket, or by directly blowing in steam; in the latter case, somewhat less water is originally added, with a proportionate increase in sulphuric acid strength, to compensate for dilution by condensation of steam. When this method is adopted, the vessel may be simply constructed by lining a cask or tank with sheet lead; whereas, for boiling over free fire, a copper vessel must be employed, iron being too readily attacked by the acid. In Evrard's process the sulphuric acid is replaced by caustic soda; the evolution of fetid smells is thereby lessened, but loss is apt to be occasioned through the formation of soap by the action of the soda on the fat.

When rough fats are rendered in a soapery for use therein, a simple method of procedure is to place the tissues to be treated in one of the soap "kettles" or "coppers" (Chap. XIX.), and blow wet steam through the mass; a large proportion of the fatty matter is then melted down, and is removed by skimming. To extract the remainder, weak alkaline leys from other operations are run in, and the whole boiled up with steam so as to convert the fat into a kind of impure soap solution, which is run off and worked up along with other inferior material in the manufacture of lower grades of scouring soaps.

When partly decomposed tissues, &c., are boiled to extract fat, much the same kinds of noxious smells are apt to be evolved as in the dry process (p. 247); accordingly, when it is essential to avoid nuisance, it is usual to box in the pans, and lead the evolved vapours to a condensing chamber where the steam is condensed, the remaining air, &c., being drawn off to the main chimney stalk of the works, by which means a continuous indraught is

set up, and outward leakage of malodorous vapours avoided. In the case of putrid materials, the mere dilution of noxious vapours with the chimney gases thus brought about is not always sufficient, and destruction of smell by fire must be resorted to in order to avoid nuisance in certain situations, such as crowded towns, and the like.

Rendering under Increased Pressure.—Of all processes

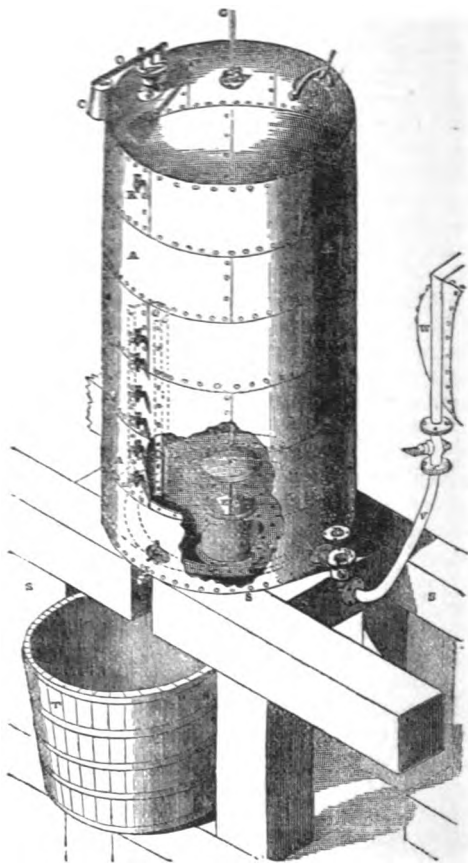

Fig. 73.

for obtaining fats from their natural animal sources this one is the most extensively used, as the higher temperature attained leads to the more complete gelatinisation of nitrogenous tissue, and consequently to the more thorough separation of fat. Fig. 73 represents a digester employed in Wilson's process for rendering

tallow and lard; a series of these is generally worked together, each of 10,000 or 15,000 gallons capacity, or even more. In large American slaughterhouses (*e.g.*, at Chicago, St. Louis, Cincinnati, &c.), each digester is kept for the production of one kind of fatty matter only, the adipose tissue being usually worked up therein within a few minutes after slaughtering; hence injury through use of stale or decomposed fatty tissue is avoided, and extremely uniform grades of lard and tallow obtained, the various portions of the carcasses being separately treated in different vessels according to the part of the body employed. The boiler is provided with a false bottom; a discharging orifice, E, covered when required by a plate, F, raised or lowered as required by the rod, G, passing through a stuffing box; an internal steam coil at the base fed with steam from an ordinary boiler by the pipe, V, and steam cock, B; and a series of draw-off cocks at the side, U, *p, p, p, p, R*. A safety valve, O, is also provided, and a manhole at the top, K. The discharging valve being closed by lowering F, the fat to be rendered is introduced through the manhole, K, until within 2 to 2½ feet of the top; the manhole being closed steam is admitted through the cock, B, until the desired pressure is obtained (usually 3 to 4 atmospheres). Much water condenses during the heating up; if requisite this is drawn off from time to time by means of the lowest cock, U, the progress of the fusion being tested and regulated by opening the top cock, R, so as to see whether steam only escapes, or melted fat. After ten to fifteen hours the steam supply is shut off and the excess pressure relieved by opening the safety valve; the whole is then allowed to remain at rest awhile so that the fatty matter and water may separate, when the former is drawn off into coolers through the side cocks, *p, p, p, p*, and the latter through the lowest cock, U. The aqueous liquor contains much nitrogenous matter in solution and is utilised for manurial purposes. The boiler is finally discharged of solid contents by raising the valve, F; the matters ejected are collected in a tub, T, and if not completely freed from fat are returned to the boiler and worked over again with the next charge.

Extraction of Fat from Bones.—Before bones are treated for the preparation of manure, animal charcoal, &c., the fatty matters contained therein are usually more or less completely extracted by one or other of a variety of processes; of these the simplest consists in boiling the bones (preferably crushed into coarse fragments) with water heated by a steam jet or otherwise; the fatty matters are thus melted out and obtained by skimming off as they rise to the top of the water. A large fraction of the total fatty matter is thus left behind in the osseous tissue through incomplete removal; a better yield is obtained when the heating is effected under increased pressure in a digester, the steam then

penetrating into the minute cavities and more completely displacing the melted fat; moreover, the nitrogenous cell wall constituents are usually gelatinised to a greater extent than is effected by open pan boiling, so as to facilitate the escape of fat; for this same reason, however, the bones thus treated are rendered poorer in organic constituents, and, therefore, less suitable as manure or for animal charcoal making; on the other hand, more soluble organic matter, suitable for glue making or for manure, &c., is obtained in the watery liquor.

Various forms of digester are in use; a useful variety consists of a vertical wrought iron barrel or cylinder some 6 feet long and 3 feet 6 inches diameter, slightly tapering at each end, and fitted with flanges to which iron discs are bolted (Fig. 74). The upper plate, *b*, serves as lid, so that when removed fresh bones can be introduced; the lower one, *c*, is slightly curved; when removed the boiled bones are discharged. A charge of 2 to 2½ tons of crushed bones being introduced the plates are bolted on steamtight, the operation being facilitated by fastening the plates on with hinges so that they are virtually doors. Steam at 3½ to 4 atmospheres pressure (56 to 65 lbs.) is then introduced for about three-quarters of an hour; when shut off the pressure is relieved, and the

whole allowed to stand for half an hour, when the condensed water and melted fat are drawn off through a tap, *f*, in the bottom plate or door. This door is then opened and the exhausted bones removed, after which a fresh charge is introduced and worked off as before. Even when operating in this way a certain amount of fatty matter is still left in the bones; to avoid this, in some Continental factories solvents are used (carbon disulphide, benzene, light petroleum distillate, &c.), the mode of treatment being very much the same as that adopted for the similar extraction of grease from vegetable marcs, engine waste, &c. (*vide* p. 236); the crushed bones being placed in suitable vessels into which the solvent is run, preferably traversing several in succession, and the fatty solution being subsequently distilled to recover the solvent and obtain the grease.

Owing to the peculiar texture of bone as compared with vegetable seeds, even this mode of treatment does not produce a perfect solution and removal of all the fatty matters present; in order to obtain a larger yield, various modifications of the plant have been introduced, whereby the solvents are made to

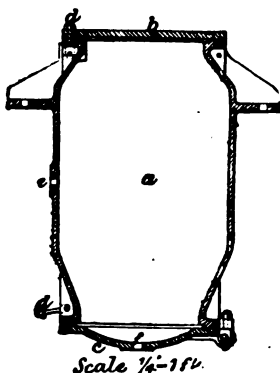

Fig. 74.

act on the crushed bones in the form of vapour. In one form of apparatus, this is effected under increased pressure (after pumping out all atmospheric air from the vessel employed), so that the solvent enters thoroughly into the pores of the bone fragments, and being attracted to and condensed by the fatty matters, forms a fluid solution of fat which exudes and runs down to the bottom, and is subsequently distilled (Seltsam's process). In

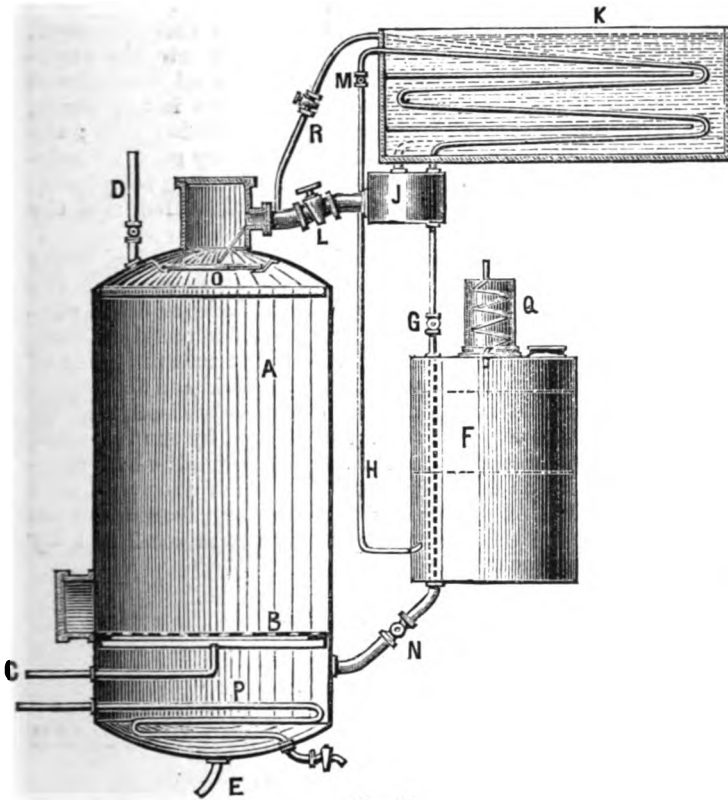

Fig. 75.

another form the crushed bones are permeated with a mixture of steam and vapour of solvent, which is condensed by a worm so as to drop down again upon the bones and percolate through them to a false bottom, where the solvent is again volatilised by a steam coil, the whole arrangement being not unlike that used for cleansing engine waste (Fig. 65, p. 237). Fig. 75 represents Leuner's apparatus arranged on this principle (Schädler).

The crushed bones are placed in A above the perforated false bottom, B. C is a steam pipe, by means of which the bones are steamed as a preliminary, the surplus steam escaping through the exit pipe D. After steaming, water and benzene are run in from the reservoir, F, into the space under the false bottom, and heated up by the steam coil, P. The evolved vapours are condensed in the worm, K, and at first run back over the bones through the cock, L, the vapour passing upwards to the worm through J, and the condensed liquid being divided into separate streams by the spreading plate, O. After some time the cock, G, is opened, so that the condensed liquid runs into the reservoir, F, instead of flowing back into A. When all the solvent has been volatilised, nothing but water condenses in the worm, which is known by means of a sampling cock attached to J; the draw off cock, E, is then opened, and the watery gelatine solution and oily matter run off into a suitable separating receptacle; A, is then discharged through a manhole and refilled, and the whole operation repeated.

Another method of operating is to introduce the crushed bones into a sufficiently strong false-bottomed vessel, from which the air is then pumped. Benzene, carbon disulphide, or other convenient volatile solvent is then run in until the vessel is filled, whereby the solvent fluid is driven thoroughly into the pores of the bone tissues. By drawing off most of the fluid and then again exhausting, the solvent is to a great extent volatilised; and by readmitting air the vapour is again condensed by the increased pressure so as to wash out the fat solution from the bone fragments. This solution runs down to the base of the vessel, and is ultimately distilled by working the air pump, leaving the fat whilst the vapour of the solvent pumped out is condensed by cooling and used over again.*

CHAPTER XI.

REFINING AND BLEACHING ANIMAL AND VEGETABLE OILS AND FATS, WAXES, &c.

SUSPENDED MATTERS.

OILS and fats as obtained by many of the processes in ordinary use contain various impurities partly in suspension, partly in solution. Of these the most objectionable are the gummy

* For further details of bonefat extracting plant *vide* Schäüler, *Technologie der Fette und Oele*, 2nd Edition, edited by Lohmann, p. 928, *et. seq.* Also for Seltsam's process, *Journ. Soc. Chem. Ind.*, 1882, p. 112.

mucilaginous or albuminous matters which generally accompany expressed oils and rendered fats to a greater or lesser extent, because unless speedily removed they are apt to undergo fermentative or putrefactive changes, which not only induce hydrolysis of the glycerides (p. 10) but also charge the oil with malodorous bye-products of decomposition, rendering the oil "rancid." Substances of this kind are usually chiefly in suspension in the oil; so that by passing the freshly expressed oil through a filterpress (p. 228), a considerable proportion of the suspended matter is removed, rendering the oil in many cases sufficiently clear and free from visible impurities to be at once saleable. Sometimes, however, the suspended matter is present in a form where filtration alone produces only an insufficient amount of purification, and where even prolonged standing does not efficiently clarify the oil by subsidence; this happens more especially when the mucilaginous matter is disseminated throughout the oil in a sort of highly diluted jelly-like condition, somewhat analogous to colloidal gelatine or thin starch paste, where the constituent particles are mostly too fine to be stopped by means of ordinary porous filtering media, or to gravitate rapidly. In such cases special mechanical or chemical treatment must be resorted to in order to coagulate the mucilaginous matter: sometimes simply heating produces this effect, the albuminous substances being solidified and coagulated somewhat like white of egg. This is conveniently effected by blowing steam through the oil by means of a fine rose jet; the condensation of water facilitates the action as the coagulated albuminous matter attracts moisture and becomes increased in bulk and deposits more readily as a flocculent precipitate on standing. The addition of small quantities of various chemicals often produces an analogous effect; thus a small percentage of sulphuric acid, or of concentrated zinc chloride solution (sp. gr. 1.85), well agitated with the oil causes on standing the gradual deposition of mucilage, along with most of the acid, the rest being subsequently removed by agitation with water. Oils containing resinous matter (*e.g.*, cotton-seed oil) as well as mucilage are preferably refined by similar treatment with alkalies, the resin being thereby dissolved out and removed as well as vegetable mucus.

The purely physical action exerted by particles of suspended matter as regards attracting the colloidal mucilage often serves to remove the latter; thus clay, fuller's earth, sand, particles of oilcake, powdered charcoal, and similar materials, when well agitated with the oil or melted fat to be treated, tend to unite with the mucilage, in such fashion that by allowing the whole to subside, or by filtering it, the whole of the suspended matter is simultaneously separated.*

* In many cases a very satisfactory degree of purification is readily effected by simply adding to the mucilaginous oil, as it runs from the press,

In certain cases the addition of chemicals that combine with the albuminous matter forming precipitates answers the same purpose; thus oakbark infusion and other forms of tannin solution, when well agitated with the oil to be treated, cause the formation of insoluble tanno-gelatinous matter which precipitates on standing carrying down with it most of the colloidal suspended matter. Various metallic salts (copper sulphate, manganese sulphate, lead acetate, &c.) are sometimes used with a similar object. A process of this kind sometimes used for cleansing rancid tallow is to boil up with a small quantity of soda ley; the melted fat is removed from the soap produced by ladling off, and then boiled up with a weak solution of alum; after settling, the purified tallow is again run off and heated by itself to 150° C. and upwards, whereby it becomes greatly whitened and hardened.*

Dissolved Matters.—Other impurities are dissolved in the oil, and the complete separation of these is in many cases impracticable. Resinous matters are the commonest impurities found in solution; these are generally of a feebly acid character, so that agitation with small proportions of alkaline solution removes the larger part or even the whole of these. For this purpose soda, potash, milk of lime, and calcined magnesia are employed in different instances; carbonated alkalies and alkaline earths (carbonate of soda, lime, &c.) usually act only imperfectly. When the proportion of resin is at all large the saponaceous compound formed sometimes separates only with difficulty from the clarified oil; agitation with saline solutions (sulphate of soda, or common salt, &c.) in such cases generally causes the mass to separate into three layers on standing: the lowest one a watery fluid containing chiefly inorganic salts in solution; the uppermost, clarified oil; intermediately, a more or less frothy spumous mass of "foots." Frequently this contains so much unaltered oil mechanically entangled as to be a highly valuable material for soapmaking, the resinous soap also present usually not interfering with this application.

Bonefat extracted by boiling processes generally retains in solution phosphate of lime and other calcium salts to an extent greatly interfering with the preparation of soap from this material: boiling with dilute sulphuric or hydrochloric acid converts the lime into calcium sulphate or chloride, and completely removes these inorganic dissolved impurities, the operation being very simply performed by placing the fat in a tank lined a small quantity of cake parings ground up by edgestones (p. 219), and then passing the whole through a filterpress; the residue left in the filterpress is returned to the kettle and worked up with fresh crushed seed, &c. Still better clarification may often be effected by heating the mixture of oil and parings, so as to coagulate albuminous matter, and then passing through the filterpress.

* *Oil Trade Review*, Oct. 1884.

with sheet lead along with a sufficient quantity of highly diluted acid, and blowing wet steam through the mass so as to agitate it thoroughly. Sulphuric acid has the advantage of cheapness and of acting less on the lead than hydrochloric acid; on the other hand insoluble calcium sulphate forms and is deposited, whereas calcium chloride, being readily soluble, does not separate in the solid form.

Certain oils when chilled deposit the less readily fusible constituents as "stearines" (p. 110); on subjecting these to filtration and pressure, an oleine practically free from suspended albuminous matters generally results, any such impurities being mostly retained along with the stearine. A partial separation of stearine by allowing to stand at a relatively low temperature, is accordingly sometimes resorted to as a means of clarifying and refining oils, more especially the more expensive edible oils ("salad" oils); the thickened mass being filterpressed whilst chilled, or on the small scale being strained through rough filters of moss, cotton wool, charcoal, &c., placed between the perforated bottoms of two boxes, one just fitting inside the other. Oils that have been thus treated are sometimes termed "winter oils"—i.e., oils still remaining fluid in winter; whilst untreated oils that become turbid or partially solidify on chilling and are only clear in warm situations are designated "summer oils."

Oil or Fat.	Percentage of Unsaponifiable Matter.	
	Allen & Thomson	Schädler.
Cotton seed oil,	1·64	1·85
Coker butter,	0·80
Hempseed oil,	1·00
Japanese wax,	1·14	1·20
Cod liver oil (brown), . .	1·32	1·45
" " (light),	0·46	0·50
Linseed oil,	1·10
Almond oil,	0·45
Poppyseed oil,	1·15
Olive oil (yellow),	0·75	0·80
" " (green),	1·50
Palm butter,	1·25
Rapeseed oil (crude), . . .	1·00	1·30
" " (refined),	0·15
Hog's lard,	0·23	0·30
Tallow,	0·50

Even after as complete a removal as possible of suspended albuminous and mucilaginous matter and of dissolved resin, most natural oils and fats contain in solution small quantities of non-saponifiable nonresinous matters; in some cases cholesterol or

isomerides thereof (ischolesterol, phytosterol, &c.) have been identified as present—*e.g.*, in olive oil. The figures quoted on p. 257 are given by Allen and Thomson* and Schädler† as representative ones in various cases.

The following figures were obtained by Thomson and Ballantine‡ in the course of an extended examination of numerous samples of oils:—

Name of Oil.	Percentage of Unsapoifiable Matter.
Olive oil (13 kinds),	1·04 to 1·42
Cotton seed oil (crude),	1·12
" " (refined),	1·07
Rape oil (Colza, 5 kinds),	·58 to ·70
Arachis oil,	·54 to ·94
Linseed oil (4 kinds),	1·06 to 1·28
Castor oil,	·30 to ·37
Southern sperm oil,	37·41
Arctic sperm oil (bottlenose),	36·32
Whale oil (pale),	1·82
Seal oil (4 kinds),	·42 to ·51
Cod oil (3 kinds),	·87 to 1·87
Menhaden,	1·60

In the analysis of soap (Chap. XXI.), as the unsapoifiable substances originally contained in the fatty matters employed for the most part pass into the soap during manufacture, a correction on this score is requisite when it is desired to determine the mean equivalent of the fatty acids present (p. 172). According to the author's experience the amount of matters of unsapoifiable nature thus contained in 100 parts of fatty acids, &c., separable from the soap by means of a mineral acid generally lies between ·25 and 1·0 part, averaging near to ·5 to ·75—*i.e.*, in the case of soaps made from natural oils and fats, to which no additional unsapoifiable matters have been intentionally added. When woolgrease or Yorkshire grease (Chap. XII.) has been used, either purposely as an ingredient, or unwittingly in the form of an adulteration of tallow, &c., the proportion becomes markedly increased; with oleine soaps made from distilled oleine a few per cents. of hydrocarbons are often present, formed during the distillation of the fatty acids, smaller quantities being often found in soaps made from oleines prepared in the autoclave without distillation. When paraffin oils have been intermixed with the soap, as in the case of certain kinds of laundry soaps, the percentage of unsapoifiable matters is largely increased.

* *Chemical News*, 43, 267.

† *Technologie der Fette und Oele*, p. 61.

‡ *Journ. Soc. Chem. Ind.*, 1891, p. 233.

The fatty matters extracted by solvents from certain leguminous plant seeds (peas, lupins, &c.) contain relatively considerable proportions of glycerophosphoric choline derivatives of the nature of lecithin (p. 121): the existence of small quantities of substances of this class in oils expressed for commercial purposes is extremely probable, but little or no knowledge is extant as to how far this is the case. The husk of the seeds of *Lupinus luteus* yields to ether a crystallisable substance, *lupeol*, analogous to cholesterol, but derived from a hydrocarbon poorer in hydrogen (*vide* p. 17); whilst the seed husks of *Phaseolus vulgaris* contain a higher homologue of phenol (*viz.* *phasol*, $C_{15}H_{24}O$) together with paraphytosterol (p. 16); in all probability several such substances akin to cholesterol and phytosterol are contained in small quantities in seed oils.

SULPHURIC ACID PROCESS FOR REFINING OILS, &c. (THÉNARD PROCESS).

In employing sulphuric acid as a clarifying agent it is requisite that no large excess should be used otherwise a charring action is apt to be set up on the oil itself, darkening its colour and depreciating its value. In refining linseed oil from one-hundredth to one-fiftieth part (1 to 2 per cent.) of acid* is thoroughly intermixed with the oil in an efficient agitator at a temperature not exceeding 40° (about 104° F.), and the whole allowed to rest for 24 hours. 60 to 70 per cent. of warm water at about 60° C. (140° F.) is then well intermixed and the whole allowed to stand some days; a watery acid liquid separates at the bottom with a layer of flocculent "foots," above which is the clarified oil, which is drawn off and again agitated with warm water as before to wash out any residual suspended acid vesicles. Another method of operating (Cogan's process) is to use 1 per cent. of acid diluted with as much more of water; this is well intermixed, and after standing some hours is heated up to 100° C. by blowing in steam through a fine rose jet at the bottom of a copper vessel. This temperature is maintained for several hours, after which the whole is allowed to stand at rest so as to separate the watery acid and foots from the clear oil. In order to draw off the oil without disturbing the water and foots, a conical separating vessel is generally employed with taps at various levels so that all clear oil above a given level can be drawn off without disturbing that below.

Rape (colza) and linseed oils and certain fish oils are those most usually refined by the acid process. Oils intended for lubrication

* Hartley recommends that the acid should be diluted with water before mixing with the oil, so as not to contain more than 30 per cent. of actual H_2SO_4 .

are as a rule the least suitable for such treatment, inasmuch as the presence of free fatty acids (and *a fortiori* of possible traces of mineral acids) is a serious objection with most such substances, corrosion of bearings and shafts, &c., being apt to be thereby occasioned. For oils intended for burning in lamps the presence of any considerable amount of free fatty acids is also objectionable as tending to cause charring of the wick.

R. v. Wagner recommends the use of zinc chloride solution of sp. gr. 1.85 instead of sulphuric acid, using about $1\frac{1}{2}$ parts per 100 of oil. Albuminous impurities are equally destroyed or coagulated, whilst there is less danger of injurious action on the oil itself. Hartley finds that a strong solution of manganese sulphate answers well.

ALKALINE REFINING PROCESSES.

As already stated, processes where alkalis are used as agents for coagulating and removing mucus, albuminoids, &c., have several advantages over the acid methods, notably that free fatty acids and resins are also removed. The quantity and strength of the alkaline ley employed varies with the nature of the oil to be treated; any undue excess is apt to lead to more or less considerable loss, not only by producing more saponification but also because the extra amount of saponaceous products gives rise to the formation of more foots containing clarified oil entangled therein. The requisite quantity of ley and the oil are well agitated together by any suitable mechanical mixer (either in the cold or heated to the requisite temperature, as the case may require), and the whole then allowed to settle; a heavier watery fluid with soapy foots separates; this is drawn off and the process repeated with a much weaker alkaline solution, and subsequently with plain water. When considerable quantities of resin are present, as in the case of cotton seed oil, the ley may conveniently be of sp. gr. 1.06 up to 1.10; in such cases it frequently happens that the watery layer and foots will not separate thoroughly from the oil without the subsequent addition of a little salt or brine. To avoid the formation of emulsions Hageman employs as purifying agent soda crystals heated to about 80° so as to fuse in their water of crystallisation; after intermixture by agitation the mass separates on standing into three sharply defined layers of purified oil, soapy matters, and watery fluid respectively, but without any notable production of emulsion.

Sometimes oils are required to be treated that have become more or less rancid by keeping, owing to fermentative changes, atmospheric oxidation, or other causes, but where most of the mucilage, &c., originally present has been already removed. In such cases thorough agitation with a weak solution of caustic

soda, or a somewhat stronger one of sodium carbonate, suffices to remove the free fatty acids of low molecular weight (butyric, caproic acids, &c.) that are present, as well as others, if already formed by hydrolysis; and to dissolve out most, if not all of the malodorous non-acid products of decomposition, so as to sweeten the oil. Diluted milk of lime and calcined magnesia are sometimes used in a similar fashion. As a rule oils that have once become rancid, even if pretty thoroughly sweetened by such refining, are more apt to turn rancid again on keeping than fresh ones. In some cases agitation with water alone without alkalies suffices to wash out the objectionable decomposition products to a considerable extent; thus rank butter is greatly sweetened by simply being thoroughly worked about and washed in water.

Cokernut oil of inferior quality may be greatly improved by boiling up with about $\frac{3}{10}$ of its weight of soda lye, specific gravity 1.03, for half an hour, skimming frequently. Some 4 or 5 lbs. of salt per ton of oil are then added, and the boiling continued for another half hour. Another equal quantity of salt is then added, and the whole boiled up: after standing till next day the cleansed oil is run off from the brine and foots that have subsided.

Crude spermaceti is generally refined by processes partly involving the mechanical expression of fluid oil, somewhat after the fashion of stearine pressing (p. 229), and partly of a chemical nature, more especially boiling up with a small quantity of potash ley; this dissolves out free fatty acid formed by the hydrolysis of the cetin or otherwise, and saponifies most of the residual fluid oil, this being more readily acted upon by alkalies than cetyl palmitate itself. Simultaneously, however, some of the latter becomes saponified, and in consequence the foots contain more or less considerable amounts of potassium palmitate, &c., whilst the purified spermaceti contains an admixture of cetylic alcohol (p. 171).

Utilisation of "Foots."—The foots obtained from oils containing considerable quantities of resinous matter (*e.g.*, cotton seed oil foots) are sometimes directly worked up into soap by admixture with other materials in the soap boiling process. When their colour or nature prevents this being done, they are generally acidified so as to decompose the soaps present; the mixture of fatty and resinous acids and more or less undecomposed glycerides thus obtained is usually distilled by means of superheated steam, whereby the glycerides present are hydrolysed; the fatty acids distil over, whilst the resinous matters mostly remain behind as a pitchy mass. To some extent, however, the materials are generally broken up by the heat with the formation of high-boiling hydrocarbons and water, the former of which partly distil with the fatty acids; the result of which is

that "distilled oleines" obtained from products of this kind (p. 110) will not wholly dissolve in alkaline solutions to soaps, the hydrocarbons remaining undissolved. On agitating the liquid with an appropriate volatile solvent (ether, benzoline, &c.) a quantity of unsaponifiable matter can usually be dissolved out from the soap solution to the amount of several per cents. of the distilled oleine employed. The same remarks apply *a fortiori* to the analogous products obtained when "Yorkshire grease" (Chap. XII.), woolgrease, and similar materials are distilled by means of superheated steam.

The appliances used for such distillation with superheated steam essentially consist of a boiler for steam raising; a superheater whereby the steam is heated considerably above the temperature of the boiler, generally consisting of a coil of iron tubing heated in a flue or some analogous arrangement; a distilling vessel into which the material to be distilled is run, the steam being then blown through it in numerous fine streams by means of a rose jet at the bottom, or a coil perforated with small holes; and a condensing apparatus in which the evolved vapours and the steam are condensed. In Chap. XVI. are described the arrangements employed in the candle material manufacture for the distillation of fatty acids and glycerol by means of superheated steam; those used for the distillation of foots, recovered greases, &c., do not greatly differ therefrom.

It often happens that the solidity of a grease, &c., is greatly increased by the process of distillation with superheated steam, so that a comparatively soft grease after distillation gives a product of much stiffer consistence, and capable of yielding a considerable amount of solid "stearine" by pressure. The cause of this is not absolutely certain; but it is extremely probable that it is due to the conversion of oleic acid into isomerides of higher melting point, isoleic acid, or stearylactone, or both (p. 30); just as these products are formed by the action of zinc chloride on oleic acid (p. 142), or during the decomposition of glycerides by sulphuric acid and their subsequent distillation with superheated steam in the "Wilson" process for obtaining candle material (Chap. XVI.)

Precipitation Processes.—In some few cases mucilaginous or albuminous matters are contained in oils and fats not readily removable by mechanical means alone, such as subsidence or filtration, but readily coagulable by means of certain metallic compounds or substances containing tannin. Thus in "boiling" linseed oil to improve its drying qualities (Chap. XIV.) sulphate of zinc, acetate of lead, sulphate of manganese, and other metallic salts are sometimes used not only for the purpose of facilitating the incipient oxidation and physical alteration required to make the oil dry to a varnish more rapidly, but also in order to combine with, and remove by subsidence, the last portions of

vegetable mucilage, &c., not entirely removed by previous refining operations. Some kinds of fish oils are similarly improved by vigorous agitation with oakbark infusion or other liquors containing tannin, conveniently effected by blowing a rapid current of steam through the whole: gelatin is thus precipitated and removed by deposition on standing, any excess of tannin taken up by the oil being subsequently removed by agitation with lead solution or other appropriate metallic salt. Copper sulphate solution, alone or mixed with brine, when thoroughly intermixed with fish oils, may often be used effectively for removing gelatin, &c., therefrom by precipitating it as an insoluble compound.

H. Nordlinger has recently patented* a process for refining vegetable oils and precipitating mucilaginous matter consisting of the preparation of "purification-oils" by dissolving in from 10 to 20 parts of oil the zinc, cadmium, iron, manganese, lead or copper salts of the higher fatty acids (metallic soaps), at a temperature of about 150° C., and allowing to clarify by subsidence. From 5 to 10 per cent. of the metallic soap solution thus prepared is then added to the oil to be treated and the whole allowed to stand some time, when precipitates are formed by the interaction on one another of the mucilaginous matter and the metallic compounds; the clear supernatant purified oil is drawn off when the action is complete.

Hartley and Blenkinsop have patented (No. 11629, 1890) the use for refining linseed oil of a solution of manganese linoleate in oil of turpentine or other suitable solvent: 1 part of manganese salt to 800 of oil suffices. If much mucilage is present the oil is previously treated with sulphuric acid of 30 per cent. By blowing a current of air or oxygen through the mass at a temperature of about 190° F. (88° C.), bleaching is readily effected, the manganese salt acting as a carrier of oxygen.

BLEACHING OILS AND FATS.

The colours exhibited by certain oils and fats, as obtained from their respective sources, are in general due to the presence of natural organic colouring matters (xanthophyll, erythrophyll, chlorophyll, &c.) in solution in the oil; in some cases these are mostly mechanically carried down by the mucilaginous matter present during clarification by subsidence, &c., more especially when heat is also applied to promote the coagulation of albuminous impurities, and particularly when oakbark or other sources of tannin are employed as precipitants of these bodies; in some instances albumin or gelatin is purposely added along with tannin, to precipitate the colour. Some colouring matters are removable by treatment with animal charcoal and filtration

* German Patent, No. 58959.

somewhat after the fashion of sugar refining; exposure to a moderately high temperature destroys others; whilst in yet other cases chemical bleaching agents are requisite, such as oxidation by the action of air blown through the heated oil, either alone or in presence of oxygen carriers; or chlorination by means of small quantities of bleaching powder or chlorate along with hydrochloric acid; or both together by means of potassium dichromate and dilute hydrochloric acid. With high priced substances such as beeswax, bleaching by exposure to air and light in thin cakes or ribbons, and in some cases treatment with nitric acid or peroxide of hydrogen, is applicable, although the cost of labour and chemicals is prohibitive of such methods in the case of the cheaper oils, &c. On the other hand, reducing agents, such as ferrous sulphate or sulphurous acid, answer better than oxidising ones with some kinds of oils—*e.g.*, linseed oil.

Hot Air Process.—Certain fats, especially tallow and palm butter, can be pretty thoroughly decolorised by heating them and passing a current of air through the dry mass (containing no interspersed water) by means of a large rose with fine orifices, so that many fine streams of air bubbles rise through the hot fat. A temperature somewhat short of that of boiling water generally suffices (80° to 90° C.) In the case of palm oil a somewhat higher temperature, 125° to 130° C.,* also effects the destruction of the colouring matter in the absence of air; a considerable amount of the glyceride is thereby decomposed with evolution of acrolein, and formation of free palmitic acid. Many fish oils are greatly lightened in colour by blowing air through the mass, heated to near 100° in a steam jacketted vessel; in these cases the oil itself generally becomes more or less oxidised, increasing in density and viscosity, especially if the air-treatment be carried too far (*vide* "blown oils," Chap. XIV.) In Hartley and Blinkinsop's process for refining linseed oil (*supra*), the oxidising action of the air is intensified by adding a manganese soap which acts as a carrier of oxygen.

Instead of blowing a stream of air through the oil to be treated, Teal † exposes rapeseed or linseed oil, &c., in a finely divided stream to air at a temperature of about 170° F. (71° C.), in order to "brighten" the oil.

W. Mills ‡ bleaches and purifies nondrying oils and fats by means of a mixture of hot air and volatilised sulphur trioxide, SO₃, passed into a "mixer" capable of withstanding a pressure of 2 atmospheres. The sulphur trioxide acts as an oxidising agent, becoming reduced to sulphur dioxide, which also is effective, especially whilst nascent.

* 240° C., according to Pohl, who first introduced the process. *Dingler Polyt. Journ.*, cxxxv., 140.

† Eng. Patent Spec., 18,744, 1892.

‡ Eng. Patent Spec., 18,224, 1891.

Bichromate Processes.—In the bleaching of raw palm oil by Watts' bichromate process, the oil is rendered quite fluid by heating it to 40° to 50° C., and is intermixed with 1 to 1.25 per cent. of its weight of potassium dichromate dissolved in hot water (22 to 28 lbs. per ton). Strong hydrochloric acid solution to the extent of 2 to 2.5 per cent. of the oil is then run in with vigorous agitation, enough being used to ensure that a slight excess of free acid shall finally be present in addition to that neutralised by the chromium and potassium. The reddish orange hue changes rapidly, first to a dark brown, then to a brownish green, and finally to a light green, the operation taking only a few minutes. The whole is then heated up by blowing wet steam through, and allowed to stand at rest for some hours; the supernatant bleached oil is drawn off and used directly for soapmaking, &c., or is washed by agitation with hot water, and standing to remove traces of chrome liquor. The "green liquor" resulting from the operation is sometimes worked up to recover the chrome by adding milk of lime so as to form a precipitate of chromium hydrate mixed with lime; this is washed and drained, and then roasted, whereby oxygen is taken up and calcium chromate formed, used for a fresh batch instead of potassium dichromate. When there are difficulties as to running waste chrome liquors away into water courses, &c., this method of regeneration is practically imperative; but unless a proper amount of scientific skill and supervision is exercised (not always available in a soapery), the cost of labour and fuel, &c., is apt to materially outweigh the value of the potassium dichromate saved, except when the price of this salt is unusually high.

Instead of hydrochloric acid, a mixture of two parts sulphuric acid and three common salt may be employed, the latter being dissolved along with the dichromate, and the former gradually run in to the mass after having been diluted with about twice its bulk of water. If the temperature be too high, the bleaching is not always successful, a brownish "foxy" shade being developed; about 45° to 50° C. may be taken as a working maximum; the proportion of dichromate used need not exceed 28 lb. to the ton ($\frac{1}{\pi 0}$ part = 1.25 per cent.) in skilled hands.

A similar mode of treatment is available with many other oils, the use of hydrochloric acid to generate nascent chlorine not being necessary in all cases; thus with various fish oils a few pounds of dichromate to the ton, with about half as much sulphuric acid, answer best, the oxidation being completed by adding a small proportion of nitric acid largely diluted, and boiling up with steam. In other instances, treatment with dichromate improves the product, not so much by simply bleaching as by oxidising and removing the small quantities of malodorous substances present that communicate a foetid or rancid odour—*e.g.*, kitchen grease, horse grease, &c.

Beeswax is frequently bleached by boiling with a weak solution of potassium dichromate, acidulated with sulphuric acid. The product is apt to retain chromium compounds, giving it a greenish hue; boiling up with oxalic acid solution appears to be the best mode of dissolving out the chrome and furnishing a white product. Instead of "chromic liquor," dilute nitric acid is sometimes employed, taking care not to use too much or of too great strength, otherwise more or less considerable loss is apt to occur through oxidation of the wax itself.

Wax thus bleached by oxidising chemicals is generally more crystalline than air bleached wax, and consequently not so well suited for the manufacture of wax candles. According to Leopold Field,* whilst the solubility in alcohol of air bleached wax differs but little from that of the raw wax, that of chemically bleached wax is much greater, leading to the idea that free fatty acids are largely formed during the bleaching process, giving greater crystallinity.

Instead of potassium dichromate, manganese dioxide has been employed for bleaching oils, especially palm oil; the powdered substance suspended in water is intermixed with the oil by vigorous agitation, and hydrochloric acid added so as to generate chlorine, whilst the whole is heated by blowing in steam. The only advantage of the process seems to be the lessened cost, against which several other inconveniences must be set off, the action being far less regular. The same remark applies to the process formerly used to some extent where manganese dioxide and sulphuric acid were employed.

Chlorine Processes.—Chlorine evolved from substances other than potassium dichromate and hydrochloric acid is sometimes employed as a bleaching agent; thus tallow may be bleached by boiling it on a solution of bleaching powder or potassium chlorate to which hydrochloric or sulphuric acid is added; about 2 to 2.5 lbs. of chlorate per ton usually suffices. In all such processes, when the fat is intended for soapmaking, excess of chlorine is apt to produce a worse result than none at all so far as colour is concerned (leaving deodorising out of the question); for if the fatty glycerides themselves are sensibly attacked by the chlorine after the colouring matters have been destroyed, the resulting soap is apt to "work foxy"—*i.e.*, either to become brown in the pan during boiling, or to darken in colour subsequently when cut up into bars. On the other hand, the unpleasant odour of rancid tallow and grease from tainted or putrid carcasses, tannery refuse, and suchlike materials is apt to be communicated in some degree to the resulting soap unless the grease is previously deodorised by chlorine, &c. In many cases a great improvement in odour may be brought about by simply blowing steam through

* *Journ. Soc. Arts*, xxxi., p. 836.

the melted grease for some time, the volatile evil-scented matters present being thus largely expelled.

With rank fish oils larger proportions of bleaching powder are requisite up to 1 per cent. and upwards, with an equivalent quantity of sulphuric acid; the bleaching powder is made into a milk with water and well intermixed with the oil, which is slightly heated by blowing in a little steam; the acid diluted with several times its volume of water is then run in with vigorous agitation. Finally, steam is blown through and the whole allowed to rest and subside.

Chlorine bleaches wax readily, but chlorosubstitution products are apt to be formed, so that if the bleached wax is used for making tapers or candles, hydrochloric acid vapours are evolved when these are burnt, causing considerable annoyance.*

Cotton seed oil in the raw state contains a peculiar colouring matter capable of being dissolved out along with resinous matters by agitation with aqueous solutions of caustic alkalies (p. 260). Sometimes this purification is only partly carried out, the residual colouring matter being destroyed by boiling with a dilute solution of bleaching powder and treatment with dilute sulphuric acid. The oils thus more or less completely refined and decolorised by chemicals are, as a rule, only used for soapmaking and similar technical purposes; whereas those completely refined by soda alone are used as edible oils, being largely used for cooking purposes, and to a great extent intermixed with olive and other high-priced "salad" oils. As a rule each oil refiner has his own particular special methods of effecting the final clarification and finish of such superior products, which are looked upon as valuable trade secrets.

Dark coloured soaps are sometimes bleached more or less completely by intermixing with the hot curd freed from ley, a solution of "chloride of soda" (bleaching powder made into a cream and treated with enough carbonate or silicate of soda to remove all lime from solution). This may be effected in the pan itself, but is best done by crutching the liquid into the soap in the frame (A. Watt): the precipitated carbonate or silicate of lime need not be previously removed. If made from coarse rank "goods," the soap will be largely deodorised by the process.

Peroxide of Hydrogen Process.—The bleaching action of peroxide of hydrogen on certain forms of organic colouring matters has long been known and utilised in certain cases where the cost was not prohibitive—*e.g.*, in the manufacture of various

* The important chemical discovery that "electropositive" hydrogen could be replaced in organic compounds by highly "electronegative" chlorine without materially altering the character of the substance affected was first made in consequence of investigations carried out by Gay Lussac in order to elucidate the cause of this occurrence in the reception rooms of the Emperor Napoleon I., where wax candles were largely burnt.

high-priced toilet fluids for converting dark hair into substances of golden hue, or even bleaching completely white. Notwithstanding improvements whereby the cost of manufacture of peroxide of hydrogen is greatly reduced, this substance is still too expensive for use on the large scale for low-priced oils, &c., although in many cases it is well fitted for the purpose. Drying oils required for artists' varnishes are sometimes bleached by floating them in a thin layer on the surface of hydrogen peroxide dissolved in water, the whole being warmed and if possible exposed to sunlight to facilitate the operation. By shaking up repeatedly in a closed vessel with about $\frac{1}{10}$ part of a 10 per cent. solution of peroxide of hydrogen most oils can be rapidly bleached, or at least greatly lightened in colour.

Wax Bleaching by Exposure to Air.—The effect of light and air on beeswax in removing the natural yellowish tinge is utilised thus: The wax is first melted and boiled up with water acidulated with a small quantity of sulphuric acid (about 1 part by weight of oil of vitriol per 1000 of wax); impurities are thus washed out, and a clear bright melted wax obtained. This is then run from a sort of cullender pierced with holes on to a drum half immersed in a tank of cold water; as the streams of fluid wax come in contact with the cool wet surface they solidify into thin ribbons which are scraped off the drum after they have passed down under the water so as to complete their solidification. Finally, the ribbons are spread out in thin layers on canvas sheeting, and placed in the open air so as to be exposed to the sun and air. After a time, the partially bleached ribbons are remelted and again cast into ribbons, and exposed for a further period, the whole operation lasting several weeks according to the weather and the nature of the wax, some kinds yielding much more rapidly to atmospheric oxidation than others. Usually only the outer portions of the ribbons become bleached, the action not penetrating far into the interior; so that to expose the whole equally to light and moisture, the mass requires to be turned over from time to time and sprinkled with water; obviously the thinner the ribbons are, the better.

In the purification of Japanese wax a very similar process is adopted; the crude wax as obtained from the dried berries of the *Rhus succedanea*, is melted and strained, dripping into water kept agitated so that it solidifies in thin flakes; these are then exposed to sun and air in trays, being now and then sprinkled with water and turned over; the vegetable colouring matter present in the crude wax is thus readily blanched, an almost white product being obtained. In the case of some varieties of beeswax this result cannot be so readily secured, the colour sometimes not yielding at all readily to atmospheric influences. Addition of a small quantity of fatty matter to beeswax often facilitates the bleaching action of the atmosphere

under the influence of sunlight; according to some authorities the quality of the wax is not improved thereby, whilst the presence of glycerides is usually regarded as proof of adulteration; on the other hand, A. & P. Buisine (*infra*) state that the addition of 3 to 5 per cent. of tallow is universal amongst French airbleachers in order to prevent the product becoming brittle, and is not regarded at all as an adulteration. A small percentage of oil of turpentine is sometimes used instead of fatty matter; the volatile hydrocarbon mostly escapes during the process by exposure to air; but a small quantity becomes resinised by oxidation and retained by the wax; probably this oxidation gives rise to peroxide of hydrogen in minute quantity which assists the bleaching action.

According to A. & P. Buisine* the chemical bleaching of beeswax is always accompanied by an increase in the total acid number, and a diminution in the iodine number, indicating the direct addition of oxygen to the unsaturated acids present; thus the following figures were obtained in a long series of experiments:—

	Iodine absorbed by 100 parts of wax.	Total acid number.
Pure yellow waxes,	10·87 to 11·23	91 to 95
Pure airbleached waxes,	6 to 7	93 to 100
Airbleached, with addition of 3 to 5 per cent. of tallow,	6 to 7	105 to 115
Airbleached with addition of 5 per cent. spirit of turpentine,	6·78	100·4
Bleached by hydrogen dioxide,	6·26	98·4
Decolorised by permanganate,	2·64 to 5·80	92·2 to 103·3
Decolorised by bichromate,	1·08 to 7·94	98·9 to 107·7

On the other hand, decolorisation by means of animal charcoal caused no marked alteration in either the total acid number or the iodine absorption.

An indirect method of bleaching by means of air is sometimes practised, especially with linseed oil; the oil to be treated is agitated at intervals with ferrous sulphate solution; this has a tendency to peroxidise by absorption of oxygen from the air, whilst the resulting ferric compound parts with oxygen to the colouring matter, oxidising the latter and blanching it, whilst becoming itself again reduced to the ferrous state; and so on continuously.

* *Bulletin Soc. Chim., Paris, 1890, iv., p. 465.*

CHAPTER XII.

RECOVERY OF GREASE FROM "SUDS," &c.

IN certain textile industries, more especially the woollen manufacture, and to a somewhat lesser extent the silk and cotton industries, the materials are treated at particular stages of the process with soap liquors for the purpose of washing out impurities of various kinds; whilst in various dyeing operations soaping is also resorted to for the purpose of clearing off superfluous dyestuff, cleansing the undyed portions, and so on. Formerly, the "soap suds" thus produced were thrown away by running into the nearest available stream, &c.; but the great amount of river pollution thus brought about has in many cases rendered it imperative that at least some amount of purification of such liquors should be effected before they are thus run away; whilst the value of the fatty matters saved by adopting proper processes for such purification, often renders it profitable to employ such methods, even when so doing is not otherwise compulsory.

The methods adopted necessarily vary to some extent with the nature of the materials to be dealt with; in cases where coloured waste liquors from dyeworks, &c., constitute the great bulk of the substance to be treated, the cheapest and most satisfactory methods appear to be modifications of the precipitation processes employed in similarly dealing with sewage; thus by adding a small proportion of milk of lime to the liquors, and simultaneously running in a solution of crude aluminium sulphate,* the alumina and ferric oxide precipitated by the lime unite with the colouring matters forming "lakes," which ultimately subside by gravitation in suitable settling tanks, carrying down mechanically with them various other impurities (albuminoid matters, fatty acids, &c.), so as finally to yield a clear almost colourless effluent containing in solution only non-precipitable matters such as alkaline salts, &c. The "sludge" thus resulting is usually of but little value, even for manure. When, however, soap suds constitute a sufficiently large proportion of the waste liquors, it is preferable to collect and treat these *separately* so as to recover

* Aluminoferric cake containing somewhat large amounts of iron, chiefly obtained from the mother liquors of purer aluminium sulphate made by treating bauxite, clay, &c., with sulphuric acid.

the grease, the slightly acid watery liquors left after this operation being either run away directly, or, preferably, admixed with the coloured waste liquors, and the whole treated together as above described; a little more lime is requisite in this case to neutralise the free acid contained in the grease recovery liquors, which must be done before the alumina can be effectively precipitated from the sulphate. The precise details of the method of working necessarily vary in each instance; but it is within the author's knowledge that processes substantially of the character described can be so worked as to answer the purpose in most satisfactory fashion, especially when carefully carried out under pressure of an impending injunction.

Two methods of treating soap suds are thus applicable; in one the soap is made to react upon a lime compound such as thin milk of lime or solution of calcium chloride so as to form insoluble lime soaps by double decomposition; these are collected by subsidence and filtration (the more or less purified liquor being run away), and subsequently decomposed by sulphuric or hydrochloric acid so as to liberate the fatty acids, thus obtaining a more or less impure grease; after hot pressing or filtration the fatty acids are obtained separate from the solid matters admixed with them, and may be utilised in the production of rough soap, cart grease, &c., or submitted to distillation with superheated steam, according to their nature and degree of impurity. This lime process is more especially applicable to comparatively dilute suds, &c., where the object is rather to get rid in some way or other of a dirty waste liquor which, from the circumstances of the case, *must* be somewhat purified before discharging, than to work a recovery process profitable in itself. When, however, the soap liquors are more concentrated, the other method is preferable, consisting of simple acidulation of the suds with sulphuric* or hydrochloric acid; the fatty acids thus liberated would naturally float up as a sort of greasy scum, were it not for the presence of other heavier suspended matters which, in most cases, and more especially with wool scouring soap suds, render the total precipitate ("magma" or "coagulate") somewhat heavier than the watery fluid, causing it to sink. This process is more especially employed in the recovery of "Wakefield fat" or "Yorkshire grease," which essentially consists not only of free fatty acids derived from soap, but also of wool grease contained in the raw wool, and other oleaginous matters used in the spinning and weaving processes.

In the English woollen industry, the method of cleansing wool usually adopted essentially consists in scouring with soft soap, or

* Chamber acid suffices, or acid from the Glover tower, rectified oil of vitriol being too costly, except in cases where the less cost of carriage of the smaller bulk outweighs the increased price through cost of further concentration.

other soaps of special character; during the further processes through which the wool is put before it is finally converted into woven cloth, soap and oil are tolerably freely used in the spinning, fulling, and milling of the fibre, yarn, and cloth. The soap suds and similar waste liquors produced in these various operations are collected in large tanks or reservoirs, holding several thousand gallons, and acidulated with a mineral acid—*e.g.*, B.O.V. (brown oil of vitriol); after agitation and subsequent standing for some hours, a fatty "magma" or coagulate deposits at the bottom of the tank; the supernatant watery fluid (which should be slightly *acid*, otherwise the whole of the soap has not been decomposed) is then run off, and the tank filled up with fresh suds and acidulated as before, excepting that somewhat less acid is now requisite, owing to the smaller quantity of suds treated, the tank having been partly filled with magma and watery fluid (with a tank 6 feet deep, the magma, &c., usually fills up 15 or 18 inches). The process is again repeated, the magma (known locally in Yorkshire as "sake") being ultimately thrown on filter beds, where most of the remaining watery liquor separates, and then subjected to pressure in bagging: at first the pressure is very gently applied, so as to squeeze out water only, but subsequently it is increased and heat applied (hot press), so as to filter the fused mass through the bagging, furnishing a dark sticky grease, and a residual "sudcake" available as manure. This grease is what is properly called "Yorkshire grease;" but similar recovered products ("Fuller's grease") obtained by treating the soap suds produced in other industries where scouring with soap is largely employed, are sometimes included in the term (cotton industry, silk manufacture, dyeing, &c.) Genuine Yorkshire grease from wool scouring essentially consists of the free fatty acids derived from the soap used, the wool grease contained in the wool, and such unsaponified oil and mineral hydrocarbons, &c., as may have been used in the spinning and weaving operations for the purpose of oiling or sizing the yarn, &c.; whilst analogous greases from other sources are more or less different as regards the nature of the substances present other than free fatty acids.

According to Lewkowitsch,* Yorkshire grease rarely, if ever, contains unsaponified glycerides, any glyceridic oils used in the spinning process becoming saponified during the after processes of washing, &c.; so that the essential organic constituents are—(1) free fatty acids, partly derived from the wool grease, but chiefly from the soaps used in washing; (2) cholesterol and isocholesterol ethers, and similar derivatives of other high alcohols—*e.g.*, cetylic and cerylic alcohols; (3) free alcohols (cholesterol, &c.), either naturally contained in wool grease, or

* *Journ. Soc. Chem. Ind.*, 1892, p. 134.

produced during scouring by the partial saponification of their compound ethers; together with hydrocarbons contained in the oils used for greasing during spinning, &c.

Analysis of Yorkshire Grease.—The free acids are usually determined by titration in the usual way (p. 116), their average molecular weight being *assumed* to be some constant value—*e.g.*, 282 = oleic acid; inasmuch, however, as they usually contain a notable amount of acids of much higher molecular weight, derived from the wool grease, this mode of calculation is apt to give too low a result. In order to obtain a more exact valuation, the alcoholic soap solution thus formed may be diluted with water, and shaken with ether or light petroleum spirit, so as to dissolve out all other constituents (or better, evaporated to dryness and exhausted with ether or, preferably, light petroleum spirit, p. 119, as the ethereal and watery fluids are apt to form frothy emulsions, not readily separating into two liquids); the weight of the free fatty acids insoluble in water is then determined by acidulation, &c., as in Hehner's process (p. 166); by titrating these with alkali, and subtracting the amount neutralised from that neutralised during the first titration, the alkali equivalent to the soluble acids may be deduced (p. 168); so that these latter may be calculated, assuming an average molecular weight—*e.g.*, 102 = valeric acid, $C_5H_{10}O_2$.

The sum of the cholesterol ethers, &c., and unsaponifiable matters is obtained by weighing the ether or petroleum spirit extract; when only an approximately exact result is required, this may be got by difference, subtracting the fatty acids found by titration (together with water, mineral matters, &c.) from 100 (*vide infra*). The cholesterol ethers saponify only with great difficulty; the best mode of procedure is to heat under pressure with excess of double-normal alcoholic potash (in a tightly closed vessel heated to 100°): in this way a measure of the amount of compound ethers present is obtained,* so that by again *assuming* a mean molecular weight (*e.g.*, that of cholesterol stearate, $C_{26}H_{43} \cdot O \cdot C_{18}H_{35}O = 638$), their amount may be calculated. A preferable method, however, is to separate the soaps thus formed as before by means of ether, &c., dissolving out the alcohols formed by saponification (or pre-existing in the grease) and hydrocarbons, &c.; the fatty acids contained in the soaps are separated and weighed, and the alcohols, &c., obtained by evaporating off the solvent. The acetyl test (p. 186) applied to this residue allows an estimation to be made of the alcoholiform constituents, again assuming a mean molecular weight—*e.g.*, that of cholesterol, $C_{26}H_{44}O = 372$, whence the amount of hydrocarbons present is known by difference.

* If substances analogous to stearylactone (p. 170) are present, or organic anhydrides (possibly present in *distilled* grease), alkali is also neutralised by them during this operation.

The figures thus obtained will then come out as follows:—

FIRST TREATMENT.

<p style="text-align: center;">A</p> <p>Free fatty acids insoluble in water (weighed). " " " soluble in water (calculated from difference of titration).</p>	<p style="text-align: center;">B</p> <p>Compound ethers, alcohols, and hydrocarbons (weighed).</p>
--	--

SECOND TREATMENT OF B.

<p style="text-align: center;">C</p> <p>Fatty acids contained in compound ethers (weighed).</p>	<p style="text-align: center;">D</p> <p>Alcohols (pre-existing and formed by saponi- fication) and hydrocarbons (weighed). The former calculated as $C_{26}H_{44}O$ from the acetyl test; the latter by subtracting the quantity thus found from D.</p>
---	--

Since water is taken up during the saponification of the compound ethers, the sum of the organic constituents thus reckoned should exceed 100, as in the parallel case of soap when the total alkali and fatty acids present are determined (Chap. XXI.)

For certain purposes, more especially the preparation of "lanolin" or similar cholesterol products of more or less purity, the proportion of alcohols present regulates the value of the material more than does the amount of fatty acids. The presence of hydrocarbons (whether intentionally added as ingredients in the oiling process during spinning, &c., or due to adulteration of the oils thus used with petroleum products or rosin oils, or formed during distillation of grease, the "oleine" thereby obtained, p. 279, being used for wool-oiling) considerably depreciates the value of the material for these purposes: in many cases the presence of such substances in the extract D obtained as above can be indicated, and the amounts roughly judged, by treating this residue with alcohol or glacial acetic acid, in which solvents the hydrocarbons are only sparingly soluble.

For many purposes a less troublesome method of analysis suffices; thus Lewkowitsch (*loc. cit. supra*) recommends the following process for the examination of Yorkshire grease:—About 5 grammes are titrated with alcohol and seminormal alkali; another portion is similarly titrated by boiling with excess of alkali (*i.e.*, the "free acid number" and the "total acid numbers" are determined); the difference between these titrations gives a measure of the compound ethers, glycerides, and other saponifiable matters present. By means of ether (preferably, light petroleum spirit, p. 119) the "unsaponifiable

matters" (alcohols, hydrocarbons, &c.) are dissolved out and weighed, whilst the "insoluble fatty acids" and "volatile" acids are determined by the Hehner and Reichert-Meissl processes (pp. 166, 174). Thus a sample of Yorkshire grease yielded the following results:—

Unsaponifiable matters (weighed),	36·47 per cent.
Free fatty acids; insoluble (weighed—Hehner number),	20·22 „
Free volatile acids (calculated as $C_5H_{10}O_2$),	1·28 „
Combined fatty acids (calculated from difference of titrations, assuming the mean molecular weight = 327·5),	48·47 „
	<hr/>
	106·44

The excess of 6·44 per cent. thus found is partly due to the water taken up during hydrolysis of the compound ethers; probably also the assumed mean molecular weight of the combined fatty acids (327·5) is somewhat too high. On the other hand the value 282 (oleic acid) would be too low.

In the determination of the unsaponifiable matters present W. Mansbridge* recommends in place of ether the use of light petroleum spirit (commercial benzoline redistilled, collecting the part distilling at about 110° F. = 43° C.); the grease is saponified with excess of alcoholic potash (under pressure if requisite), and the product decomposed with mineral acid, whereby a mixture of free fatty acids and unsaponifiable matters is obtained. Of this a portion sufficient to yield about 0·5 gramme of unsaponifiable matter is dissolved in 50 c.c. of methylated spirit saturated with benzoline distillate, and 50 c.c. of that distillate added; the whole is heated just to boiling, directly neutralised with semi-normal potash, and then transferred to a separating funnel, where the hot benzoline solution of unsaponifiable matter, and the alcoholic soap solution, separate from one another rapidly. The alcoholic soap solution is run off, and 50 c.c. of water at 100° F. (37°·8 C.) added, and the whole agitated to wash out any soap dissolved by the benzoline. After separating by standing, the watery fluid is run off, and replaced by 40 c.c. of warm 70 per cent. alcohol: this when agitated with the benzoline removes the last traces of dissolved soap. The alcoholic soap solution first run off is agitated a second time with benzoline, and the benzoline solution purified as before: for some kinds of grease more than two such extractions are requisite, but in general two suffice.

The percentage of unsaponifiable matters (including cholesterol, &c., produced by decomposition of cholesterol ethers) thus deduced is not far removed from, but is usually somewhat less

* *Chemical News*, 27th May, 1892.

than, that calculated by assuming that the fatty acids present (free and combined as cholesterol ethers, &c.) have the mean molecular weight 282 (oleic acid), and subtracting their weight (together with water, suspended matters, &c.) from 100. Thus Mansbridge gives the following comparisons:—

	Unaponifiable Matters.	
	By extraction as above.	By titration, &c.
Pure woolfat,	{ 29·05 29·25	39·36
„ „ another sample,	{ 41·70 41·70	
West of England recovered grease,	{ 21·55 21·05	{ 23·16 23·16
West of England recovered grease, another sample,	{ 22·81	
Distilled woolfat,	{ 52·25 51·90	{ 48·64 48·64
Oleine from distilled woolfat,	{ 44·35 44·25	
Oleine from distilled woolfat, another sample,	{ 50·25 50·35	47·13
Black grease recovered from shoddy scourings,	{ 22·61 22·72	

According to A. Hess* the difference between the amounts of unaponifiable matters deduced in these two ways gives a rough valuation of the cholesteroid bodies present, the proportion of these latter being approximately deducible by multiplying the difference by 10.

The following analyses of Yorkshire grease (method of analysis not stated) are given by G. H. Hurst † as fairly typical:—

	1	2	3	4
Sp. gr. at 15°·5 C.,	0·9391	0·9417	...	0·9570
„ „ 98° „ „	0·8900	0·8952	...	0·8720
Water,	0·98	1·53	1·21	0·94
Fatty acid,	18·61	24·25	24·15	26·43
Neutral oil,	63·62	58·25	30·02	16·86
Unaponifiable oil,	11·68	15·83	44·44	55·77
Ash,	0·11	0·14	0·18	trace
	100·00	100·00	100·00	100·00

* *Journ. Soc. Chem. Ind.*, 1892, p. 144.

† *Journ. Soc. Chem. Ind.*, 1889, p. 90.

Thus, the higher the density, the greater the percentage of unsaponifiable oil. Such greases generally melt at near 44° C.; they can be saponified with alkalies, but only imperfectly; the flashing point is usually near 220° C. (p. 128).

Distilled Grease.—Yorkshire grease from wool, and analogous recovered greases from other sources, are rarely sufficiently free from odour and otherwise of general good character, to enable them to be directly used for anything but the coarsest purposes—*e.g.*, cart grease, and similar rough lubricating materials, such as that required for the hot axles of tin plate rolling machines. When subjected to distillation in cast iron* stills of about 1,000 gallons capacity, holding about 4 tons of grease, a variety of products are obtained, to some extent varying with the quality and nature of the grease. The stills are first heated for 10 to 16 hours with free fire to drive off water, and then for 20 to 24 hours more with superheated steam, during which time a pale yellow product comes over, known as “first distilled grease,” sometimes preceded by a lighter “spirit oil,” sometimes not. After the “first distilled grease,” “green oil” comes over, sometimes used for coarse lubricating greases, but more often put back into the still and worked over along with the next batch. Finally, the distillate comes over as a thick oil, when the operation is regarded as finished; the fires are drawn, the superheated steam turned off, and the pitch run out of the still: 100 parts of Yorkshire grease thus treated gave—

Pitch,	14·1 parts.
Green oil,	15·5 „
First distilled grease,	45·5 „
Spirit oil,	4·1 „
Water and loss,	20·8 „
	—
	100·0
	—

The pitch thus obtained forms a useful lubricant for the necks of hot rollers.

The “first distilled grease” is sometimes allowed to “seed” or crystallise in the usual way (Chap. XVI.), and then pressed in a hydraulic press, so as to obtain a liquid “oleine” and a solid “stearine” in about the relative proportions, 2 to 1; the oleine that exudes spontaneously from the crystallised cake before pressing, is sometimes collected apart and designated “No. 1 oil.” Or the grease is distilled a second time, so as to obtain about

* Cast iron is much less rapidly corroded by the fatty acids than wrought iron—*vide* G. H. Hurst, *loc. cit. supra.*

96 per cent. of "second distilled grease," and 4 per cent. of "soft pitch."

The "spirit oil," as it first runs from the stills, is pale yellow in colour, but darkens on keeping, probably by oxidation, like the somewhat analogous oils obtained on the redistillation of bone tar and other products of destructive distillation; it contains a small quantity of free fatty acids, equivalent to 4 or 5 per cent. of oleic acid; on redistillation, it begins to boil at near 150° C., about two-thirds distilling below 240°, and seven-eighths below 320°. It finds a limited use in making black varnish. Of what constituent of the original grease it is a product of decomposition by heat, is not known certainly; possibly it is derived from cholesterol, &c., but as hydrocarbons are always formed in small quantity in the redistillation of "red oils" (crude oleic acid) and similar substances containing little or no constituents analogous to cholesterol, it is more probable that it comes from the decomposition of the oleic acid present.

"Distilled grease" is of pale yellow colour, and of granular texture; two samples gave the following numbers (Hurst):—

	First Distilled Grease.	Second Distilled Grease.
Water,	0.98	1.04
Free acid,	63.12	66.56
Unaponifiable matter,	12.88	13.24
Neutral oil,	23.02	19.16
	100.00	100.00

Lewkowitsch found a considerably larger percentage of hydrocarbons in a sample of distilled grease examined by him, viz. :—

Free fatty acids (molecular weight = 286),	54.91 per cent.
Combined fatty acids (molecular weight = 327.5),	7.02 ,,
Unaponifiable matters,	38.80 ,,
	<u>100.73</u>

The combined fatty acids would represent about 11.28 per cent. of compound ethers ("neutral fat"), leaving 34.54 per cent. of hydrocarbons.

The "stearine" obtained from distilled grease by pressure is a hard pale yellow greasy solid; that from the "first distilled grease" is darker than that from "second distilled grease," but has usually a slightly higher melting point. Apparently the fatty acids present have a higher molecular weight than stearic

acid, inasmuch as the free acid found on analysis, when calculated as stearic acid and added to the other constituents, gives a total considerably under 100 (Hurst).* Thus—

	Stearine.	
	From First Distilled Grease.	From Second Distilled Grease.
Sp. Gr. at 15°·5,	0·9044	0·9193
„ 98,	0·836
Water,	1·48	0·6
Free acid calculated as stearic acid,	76·3	88·6
Unsaponifiable oil,	0·4	0·49
Neutral oil,	7·7	2·11
	85·88	91·80
Melting point,	57° (134° F.)	48° (118° F.)
Solidifying point,	53·5 (128° F.)	45° (113° F.)

The oleine simultaneously obtained is pale when fresh, but gradually darkens, probably owing to the presence of iron derived from the press or the tanks in which it is stored. It is generally known in the district of production as "wool oil," because it is chiefly used for oiling woollen yarns, &c.; lubricating greases and soap are sometimes prepared from it; but for the latter purpose it is not at all well suited on account of the large proportion of unsaponifiable matters. It varies much in composition, even when from the same maker, on account of the varying composition of the Yorkshire grease originally employed, the neutral oil amounting to between 9 and 28 per cent., and the unsaponifiable oil to between 10 and 38, whilst the free acid (calculated as oleic acid) constitutes 53 to 65 per cent. The flashing point usually lies between 322° F. and 342° F. (Hurst).

Engine Waste Grease and Fuller's Grease.—The grease recovered from greasy engine waste (p. 236) is closely akin to that obtained from soap suds; but owing to the large use of hydrocarbons as ingredients in lubricating oils at the present day, it is usually much less valuable, the yield of solid "stearine" being but small, and the "oleine" containing large quantities of unsaponifiable hydrocarbons. When the spindles, &c., are lubricated with tolerably pure vegetable oils or with sperm oil, &c., a much better form of grease results; but this is comparatively rare.

Grease recovered from silk soap suds and soap baths from cotton dyeing works, &c., mostly consists of free fatty acids with

* The presence of stearolactone (p. 170) might possibly explain the apparent deficiency in free acids.

but little unsaponifiable matter, and is often clean enough to be used directly for soapmaking. Its commercial valuation for such purposes is generally effected by determining the percentage of water present (p. 122), and of matters insoluble in alcohol (unsaponifiable matters), subtracting the sum from 100, and reckoning the difference as available fatty acids. When too dirty for use in even the coarsest soap, such grease is either directly utilised for lubricating materials of the roughest kind, or is distilled by means of superheated steam, and the distillate pressed for stearine and oleine.

§ 5. Classification and Uses of Fixed Oils, Fats, Waxes, &c.; Adulterations.

CHAPTER XIII.

CLASSIFICATION.

In accordance with their ordinary physical texture, sources (whether animal or vegetable), and essential chemical nature, the fixed oils, fats, butters, and waxes, &c., may be conveniently divided into twelve classes, falling into two principal divisions, according as the main components are of glyceridic or non-glyceridic nature.

DIVISION I.—ESSENTIALLY GLYCERIDIC.

A. *Fluid at Ordinary Temperatures* :—

1. *Non-drying Oils*—

Vegetable—

- (1) Olive (almond) class.
- (2) Rape (colza) class.
- (3) Ricinoleic (castor) class.

Animal—

- (4) Lard oil class.

2. *Intermediate : Drying Qualities possessed to a limited extent* :—

Vegetable—

- (5) Cotton (sesamé) class.

Animal—

- (6) Train, fish, and liver class.

3. *Drying Oils : well marked Drying Qualities* :—

Vegetable—

- (7) Linseed class.

B. *Solid or Semisolid at Ordinary Temperatures* :—*Vegetable*—

(8) Palm butter, and Japanese wax class.

Animal—

(9) Tallow, lard, and cow's butter class.

DIVISION II.—ESSENTIALLY NON-GLYCERIDIC.

A. *Fluid at Ordinary Temperatures* :—*Animal*—

(10) Sperm oil class.

B. *Solid or Semisolid at Ordinary Temperatures* :—*Vegetable*—

(11) Carnäuba wax class.

Animal—

(12) Beeswax and spermaceti class.

CLASS I.—OLIVE (ALMOND) CLASS.

A large number of oils are known completely fluid at ordinary temperatures and not congealing until greatly chilled, consisting chiefly of olein with smaller quantities of more solid glycerides (myricin, palmitin, stearin, arachin, &c.), and in some cases small admixtures of glycerides of other kinds; as a rule, however, glycerides of the "drying oil" division are either absent altogether, or only present in very small quantities, so that oils of this class are practically *non-drying*. The presence of the other constituents raises the relative density somewhat above that of pure olein (near 0.905 at 15°), usually to between .913 and .924; and at the same time tends to diminish the iodine number below 86.2 per cent., the calculated value for pure olein (p. 180), excepting in those cases where a notable admixture of less saturated glycerides is present, when the superior iodine absorbing power of these ingredients slightly raises the value instead of lowering it. The calculated saponification equivalent of pure olein is 294.7 (p. 158); that of an oil of this kind generally differs but little therefrom, being a little higher or a little lower, according as the other constituents have mean equivalent weights above or below this value. The proportion of glycerides other than those of oleic and the solid fatty acids is not large enough to interfere with the production of a tolerably hard solid elaidin with nitrous acid (p. 137), nor to cause that heat evolution on mixture with sulphuric acid to be large (p. 147).

The chief oils of commercial or local importance belonging to

this class that have been investigated to any extent are as follows:—

Name of Oil.	Source.
Almond oil (sweet), . . .	<i>Amygdalus communis</i> (<i>Prunus amygdalus</i>), var. <i>dulcis</i> .
" (bitter), . . .	" " <i>hypogaea</i> , var. <i>amara</i> .
Arachis oil (groundnut oil), . . .	<i>Arachis hypogaea</i> .
Beechmast oil, . . .	<i>Fagus sylvatica</i> .
Ben oil, . . .	<i>Moringa pterygosperma</i> ; <i>M. aptera</i> (<i>Guilandina moringa</i>).
Hazelnut oil, . . .	<i>Corylus avellana</i> .
Olive oil, . . .	<i>Olea Europæa sylvestris</i> ; <i>O. E. sativa</i> .
Plum, peach, cherry, and apricot kernel oils, . . .	<i>Prunus domestica</i> ; <i>P. persica</i> ; <i>P. armeniaca</i> ; <i>P. cerasus</i> ; <i>P. brigantiaca</i> ; <i>P. serotina</i> .
Tea seed oil, . . .	<i>Camellia theifera</i> ; <i>C. oleifera</i> ; <i>C. drupifera</i> .

Besides these, however, a large number of oils are in use to varying extents in different countries for edible purposes, burning, anointing, &c., many of which agree in their general physical characters with the above, more especially in being practically non-drying in character and only solidifying at low temperatures, and hence presumably consisting essentially of olein; the chemical examination of most of these, however, has not yet been undertaken; and as yet they are but little exported, and consequently have not found their way into general trade in any large quantities (*vide pp.* 287, 296).

Vegetable Expression Oleines.—Semisolid vegetable tallows and butters, when subjected to cold pressure, yield a solid mass of higher fusing point together with a comparatively fluid oil or oleine; in certain cases, more especially for the production of the higher fatty acids for candle making, this treatment is resorted to in order to partially separate the more fluid glycerides from the others. Cokernut and palm kernel butters when thus treated yield fluid oleines, solidifying a few degrees above 0°; these consist partly of oleic glyceride, partly of the glycerides of the acetic series of lower molecular weight contained in the original butters; and, in consequence of the presence of these latter in considerable quantity, possess a somewhat different composition from ordinary oils of the olive class—*e.g.*, the iodine absorption is much lower (often below 30 to 40) owing to the relatively small amount of oleic glyceride present; and similarly, the heat development on mixture with sulphuric acid is below that observed with olive oil (cokernut oleine = 26° to 27°; olive oil = 41° to 43°—A. H. Allen). On account of the absence of linolic and similar glycerides, these products are almost completely non-drying.

CLASS II.—RAPE (COLZA) CLASS.

The characteristic property of this class of oils is that of possessing a much higher saponification equivalent than the oils of Classes I. and III. in virtue of the presence of considerable quantities of a higher homologue of oleic acid—viz., *erucic acid*, $C_{22}H_{42}O_2$, crystallisable and melting at 34° . In the case of colza oil another acid, rapic acid, $C_{18}H_{34}O_2$, isomeric with ricinoleic acid, has been stated to be also present in considerable quantity (p. 41). More precise information, however, is decidedly wanted as regards the constituents not only of the lesser known members of the group, but also of those most commonly occurring.

The specific gravity is relatively low, mostly below $\cdot 918$; the saponification equivalent usually lies between 315 and 325, whilst the iodine number is between 95 and 105, indicating the presence of a certain amount of glycerides of linolic character,* a result also borne out by the possession of some degree of drying character by the oils themselves, not, however, of a strongly marked kind.

Oils of this class do not give a particularly solid elaidin reaction with nitrous acid, buttery masses being usually formed which often separate on standing into two portions, one solid and the other liquid.

The principal oils of this class are those undermentioned, but in all probability many of the lesser known oils are of similar composition, judging from their general physical characteristics:—

Name of Oil.	Source
Colza (rape) oil, . . .	Different cultivated varieties of <i>Brassica campestris</i> .
Hedge mustard oil (hedge radish oil), . . .	<i>Raphanus raphanistrum</i> (<i>Raphanistrum arvense</i>).
Mustard oils (black and white; Chinese cabbage oil), . . .	
Radish oil, . . .	<i>Sinapis nigra</i> : <i>S. alba</i> ; and other species of <i>Sinapis</i> . <i>Raphanus sativus</i> .

CLASS III.—CASTOR OIL CLASS.

In this class of oils the prevailing glyceride is that of an oxy-acid, such as ricinoleic acid, which gives to oils of this description peculiar chemical characteristics. Comparatively few oils besides castor oil have been sufficiently closely examined to render it certain that they belong to this class; but it is highly probable that several of the lesser known oils used locally for edible

* The calculated value for erucin is $72\cdot 4$, that for olein, $86\cdot 2$.

purposes, or as lamp oils, in different parts of the world, really consist to a greater or lesser extent of oxy-acid glycerides.

A tolerably high specific gravity, from .950 to .970, is possessed by oils of this class, and a saponification equivalent of 305 to 315 (calculated value for ricinolein = 310.67). The elaidins are soft and buttery. The following oils appear to contain more or less considerable proportions of oxy-acid glycerides :—

Name of Oil.	Source.
Castor oil,	<i>Ricinus communis</i> (var. <i>minor</i> and <i>major</i>).
Curcas oil (purqueira oil),	<i>Jatropha curcas</i> (<i>Curcas purgans</i>).
Grape seed oil,	<i>Vitis vinifera</i> .

CLASS IV.—ANIMAL NON-DRYING OILS— LARD OIL CLASS.

When comparatively solid animal fats are subjected to a regulated pressure (p. 231), a mechanical separation of the solid and liquid constituents is effected if the temperature be suitably adjusted; the fluid substances thus expressed are, strictly speaking, the only products to which the term "oleine" is applicable (besides the analogous fluid constituents of vegetable oils); but in commercial practice the fluid free fatty acids separated by similar means from the products of saponification of such fats, are also designated "oleines," as also are the analogous fluid acids obtained from steam-distilled fatty acids from greases of various kinds (p. 110); further, oils treated with sulphuric acid (Turkey red oils) are often termed "oleine" in the cotton dyeing industry. Accordingly, the glyceridic expression products are more usually spoken of as "oils" (*e.g.*, tallow oil) than as oleines; although, even then, confusion is not always avoided, since the terms "tallow oil" and "red oil" are sometimes also applied to the expressed crude oleic acid of the candle maker.

Products of this class closely resemble vegetable oils of Class I., especially when free from any animal or rancid odour betraying their origin. According to the way in which the expression is effected (more especially as regards temperature), they contain varying quantities of the solid constituents ("stearines," chiefly palmitin and actual stearin—*i.e.*, stearic glyceride) in solution, but otherwise consist essentially of olein (oleic glyceride). They usually have a specific gravity of about .915 or .916 at 15°, and solidify within a few degrees of 0° C. (above or below). With nitrous acid they form firm solid elaidins; with sulphuric acid (Maumené's test) the heat evolution is small, as compared with most other oils. The chief oils of the class are :—

Name of Oil.	Source.
Lard oil,	Hogs' lard subjected to expression.
Neat's foot oil, horse foot oil, } sheep's trotter oil, . . . }	The "feet" (hoofs and hocks) of oxen, horses, and sheep.
Tallow oil,	Ox and mutton tallow subjected to expression.

CLASS V.—SESAMÉ OR COTTON SEED CLASS— VEGETABLE SEMI-DRYING OILS.

The distinctions between this class of oils and those of Classes I. and VI. are not always very clearly marked, the differences being rather of degree than of kind, chiefly consisting in the presence of distinctly larger proportions of glycerides of Class I., although these ingredients are not contained in sufficient quantity to give true drying qualities, such as are possessed by oils of Class VI.—i.e., the power of absorbing oxygen from the air, and becoming a solid varnish-like mass. Accordingly, the effect of the elaidin test (p. 137) is to form a soft solid mass, far inferior in hardness and consistency to that furnished by typical non-drying oils, such as olive or arachis oil, but considerably more solid in character than the soft nearly fluid products formed by the true drying oils, such as linseed oil.

In general, the specific gravity at 15° is a little higher than that of oils of Class I., mostly lying between .923 and .935; and the iodine absorption is similarly raised considerably above 86.2, the theoretical value for pure olein. In most cases, solid glycerides (palmitin, stearin, &c.) are present to a greater or lesser extent, together with small quantities of glycerides of oxy-acids. The following are the best known oils of the class:—

Name of Oil.	Source.
Camelina oil (German oil of sesamé or gold of pleasure oil),	<i>Camelina sativa.</i>
Cotton seed oil,	<i>Gossypium herbaceum</i> ; <i>G. hirsutum</i> ; <i>G. barbatense</i> ; <i>G. arboreum</i> ; <i>G.</i> <i>religiosum.</i>
Cress oil,	<i>Lepidium sativum.</i>
Madia oil,	<i>Madia sativa.</i>
Maize oil,	<i>Zea mais.</i>
Niger oil (ramtil oil),	<i>Guizotia oleifera.</i>
Sesamé oil (gingelly oil, til oil, benné oil),	<i>Sesamum orientale.</i>
Sunflower oil,	<i>Helianthus annuus</i> ; <i>H. perennis.</i>

Lesser Known Vegetable Oils.—In addition to the leading vegetable oils above mentioned belonging to Classes I, II, III, and V., a large number of other oils are locally known and used to a considerable extent in various parts of the world. In most instances nothing whatever is known as to the chemical constitution of these substances; judging from their general physical characters they are, as a rule, either nondrying oils of the olive class, or semidrying oils of the cotton seed type; some, however, in all probability are more or less akin to rape or to castor oil. Amongst these lesser known imperfectly drying oils may be mentioned that derived from the soja bean (*Soja hispida* or *Glycine soja*) of China and Japan, where both the beans themselves and the oil thence expressed are important articles of food. Recently the plant has been introduced into Europe; the seeds yield about a sixth of their weight of oil by pressure, furnishing an excellent oilcake for cattle feeding. The oil itself thickens on chilling, and when exposed to air oxidises somewhat rapidly.

The nuts of the candlenut trees (*Aleurites moluccana*, *A. triloba*; *Jatropha moluccanum*, *Croton moluccanum*), found in the Eastern Archipelago, Malay, Cochīn China and Southern China; California, Chili and Venezuela; Bourbon, Mauritius, Jamaica, Polynesia and North Australia) furnish similar oils, chiefly used for cooking and burning, but sometimes possessing sufficient drying power to be capable of use for painting purposes in hot climates. In different countries the oil is known by different names—*e.g.*, Bankulnut oil, Kekune oil, &c. According to Lach a sample of candlenut fat fusing at 24° and solidifying at 21° yielded fatty acids melting at 65°·5 and solidifying at 56°: the iodine number was 118, indicating the presence of a considerable proportion of drying oils.

L. Field describes candlenut oil as limpid and sweet, not solidifying at 0°, and capable of forming a fine waxy looking soap by the cold process. It is stated to be well adapted for cloth dressing and to be largely exported to Europe for soapmaking, but does not appear to be much used in England for those purposes. The nuts are extremely hard, so as to be cracked by ordinary machinery only with difficulty; when strung on a twig they can be burnt like a tallow candle, whence the ordinary name.

The seeds of various species of pine (*Pinus sylvestris*, *P. abies*, *P. picea*) furnish by expression or solvents imperfectly drying oils used to some extent for burning and other purposes; these vary in specific gravity from ·925 to ·931 at 15°, and mostly thicken at about -15, solidifying at about -27°.

Croton oil, from *Croton tiglium*, is possessed of weak drying characters, but has a composition differing in many respects from most of the oils of the nondrying and semidrying classes. The specific gravity of the fresh oil is ·942 at 15°, older oil that has

absorbed oxygen from the air being more dense, about $\cdot 955$; solidification occurs at about $- 16^{\circ}$. The oil is strongly purgative when taken in small doses internally, and vesicatory when applied to the skin; it does not form any solid elaidin with nitrous acid. It mainly consists of glycerides, and on saponification furnishes stearic, palmitic, myristic, lauric, caproic, valeric, butyric, acetic, and formic acids of the acetic family, together with tiglic (methyl crotonic), and crotonic acids of the oleic series. Oleic acid has been stated to be present by some investigators, and to be absent by others, a nonvolatile "crotonoleic acid" yielding a barium salt soluble in alcohol having also been found. The vesicatory agent is believed to be "crotonol," a semisolid body indicated by the formula $C_9H_{14}O_2$; this is not identical with the purgative principle, the nature of which is uncertain.

An excellent fatty oil is largely used in Morocco, derived from the Argan tree (*Argania sideroxyton*, *Elæodendron argan*, or *Sideroxyton spinosum*): the fruit is fleshy and is eaten greedily by sheep and goats, cows and camels, but the kernels or stones are hard and bony, and are consequently rejected by the animals. These stones are collected and cracked, and the inner white kernels carefully roasted, ground, and kneaded with a little warm water, whereby the oil is gradually expelled, more water being added from time to time, and the mass kneaded until no more oil exudes. After settling the oil is a clear light brown fluid, often of somewhat rancid flavour and odour; it is largely used by the Moors as an edible oil, somewhat cheaper than olive oil. Somewhat similar oils are obtained from the kernels of the fruit of *Staphylea pinnata* (bladdernuts) in Eastern Europe; the berries of the dogwood (*Cornus sanguinea*) in Italy, Cashmere, and Siberia; the seeds of the spindel tree (*Euonymus europæus*) of Central Europe; horsechestnuts (*Æsculus hippocastanum*); and the seeds of *Sarcostigma Kleinii* (known as Adul or Odal oil in Southern India), of several *Hibiscus* species, and of *Pentaclethra macrophylla* (Owala oil of the Gaboon, Opochala oil of Fernando Po).

The Brazil nut or Castanha (*Bertholletia excelsa*) of South America yields a clear yellow bland oil closely resembling that of almonds, soon becoming rancid; the edible seeds of the *Telfairia pedata* of South-east Africa furnish a similar oil, said to be equal to the finest olive oil. Pumpkin seed oil (*Curcubita pepo*) is a clear sweet-tasting oil, yellowish or nearly colourless when obtained by cold pressure, possessed of only faintly marked drying qualities; its relative density is $\cdot 923$ at 15° ; at $- 15^{\circ}$ it solidifies to a greyish-yellow mass. Similar oils are obtainable from the seeds of other curcubitaceous plants—*e.g.*, the watermelon (*Cucumis citrullus*), sweet melon (*C. melo*), gherkin (*C. sativus*), colocynth (*C. colocynthis*), &c. The oil of the Boma nut (*Pycnocomia macrophylla*) is sweet and bland, and is

much used for cooking by the natives of Central Africa; that of the Cashew or Acajou nut (*Anacardium occidentale*) is similarly employed in the East and West Indies and the West Coast of Africa; in the Brazils it has been in use for centuries as an edible oil; it is a light yellow sweet-tasting oil much like that of almonds, of relative density .916. Mango seeds (*Mangifera indica*) and pistachio nuts (*Pistachia vera*) yield similar oils, as also do the fruit kernels of *Buchanania latifolia*, a forest tree common in Coromandel, Malabar, and Mysore; the oil from the last is limpid and of a pale straw colour and is sometimes known as *Chironji oil*. Various species of *Enocarpus* bear oleaginous nuts furnishing sweet cooking and eating oils, known in Para as "coumu oil," resembling olive oil but becoming solid much more readily on chilling; hickory nuts (*Carya oliviformis*), M'poga nuts (common in the Gaboon), breadnuts (*Omphalea diandra* and *O. triandra*—St. Domingo and Jamaica), and many other lesser known nuts and seeds are also sources of similar products.

According to J. R. Jackson,* a large number of new oil seeds have come into the English market of late years from the West Coast of Africa, but the supplies have mostly been intermittent; some few are particularly well adapted for use were a constant supply forthcoming, more especially the seeds of the *Telfairia occidentalis* (a cucurbitaceous plant); the *Myristica angolensis* (a scentless nutmeg); the *Hyptis spicigera* (a herbaceous labiate plant); the *Polygala rarifolia* ("Maluku" seeds); the *Lophira alata* ("Meni" or "Laintlaintain" seeds, from one of the *Dipterocarpeæ*; Senegambia and Sierra Leone); and the *Penteclethra macrophylla* (a leguminous tree, the "Owala" of the Gaboon, and the "Opachala" of the Eboe country. "M'poga," "Mabo," and "Niko" nuts also furnish oils of a character that might render them very useful.

Similar remarks apply to the oil bearing produce of many other countries; in many instances the oils thence obtainable are of characters so good for a variety of purposes as to leave little doubt that a considerable amount of trade in such materials will hereafter become developed whenever the conditions are realised necessary for the economical growth of the trees and plants, and the harvesting of their seeds, nuts, or other fruits, &c., or for their treatment on the spot for the extraction of oil; together with the necessary opening up of the districts for transport purposes, so as to enable regular supplies to be obtained. In all probability the uncertainty as to what quantity of material could be obtained, and its price, has largely militated against the importation into Europe of numerous raw materials of the kind, manufacturers not caring to expend time, skill, and capital in working up saleable products until assured on these points.

* *Journal Society of Arts*, 1891, 40, p. 122.

CLASS VI.—DRYING OILS—LINSEED OIL CLASS.

The drying oils proper principally differ from the semi-drying oils in containing much larger proportions of the glycerides of the more "unsaturated" acids (linolic, linolenic, and isolinolenic acids), these substances greatly predominating, and only comparatively small amounts of olein and of the glycerides of the solid fatty acids being present, so that these latter rarely separate in any quantity as solid "stearines" on chilling and standing.

Owing to the more or less considerable amount present of these unsaturated constituents, both drying and semi-drying oils possess higher iodine absorbing powers than the oils of the first four classes, and develop more heat on mixture with sulphuric acid (Maumené's test, p. 147). When drying oils are spread out in a thin layer they rapidly absorb oxygen from the air, increasing in weight and "drying up" to a solid varnish, which in time becomes perfectly hard and not in the least sticky or "tacky;" semi-drying oils, similarly treated, increase in weight to a much less extent, and more slowly, and never dry up thoroughly to a hard varnish free from stickiness. With nitrous acid, drying oils give no solid elaidins; semi-drying oils usually give buttery masses from which fluid matter separates.

The specific gravity of drying oils is usually distinctly higher than that of oils of Class I., generally lying between .923 and .935, and increasing as oxidation goes on until finally the dried films or "skins" are heavier than water. According to Bauer and Hazura, the drying qualities are the more pronounced the larger the proportion of linolenic and isolinolenic acids present, linolic acid contributing less markedly to the drying properties; so that an oil consisting mainly of the glycerides of oleic and linolic acids, even when the latter predominates, does not exhibit drying powers equal to that of another containing a considerable proportion of linolenic and isolinolenic glycerides. They regard non-drying, semi-drying, and drying vegetable oils as distinguishable by the following characters so far as liquid constituents are concerned:—

Non-Drying Oils contain none, or at most only small percentages, of the glycerides of either linolic, linolenic, or isolinolenic acids.

Semi-Drying Oils contain more or less considerable amounts of linolic glyceride, but little or no glycerides of linolenic or isolinolenic acid; the drying action being also retarded by the presence of more or less olein and other non-drying glycerides.

True Drying Oils contain considerable amounts of linolenic and isolinolenic glycerides, together with linolin, and but small amounts of olein and non-drying glycerides.

Obviously the exact lines of demarcation between non-drying

and semi-drying oils, on the one hand, and between semi-drying and truly drying oils, on the other, are but faintly traced ; so that it often happens that a given oil is classed by one writer amongst the oils of one class, and by another amongst those of the adjacent class.

As regards non-drying and semi-drying animal oils, it is noticeable that the fatty acids thence obtainable yield no sativic acid on oxidation by alkaline permanganate (Benedikt and Hazura) ; from which it results that linolic acid is not a constituent of oils of this class ; whereas larger or smaller quantities of sativic acid appear to be obtainable from many, if not all, vegetable oils by this treatment.

The best known drying oils are the following :—

Name of Oil.	Source.
Hemp seed oil, . . .	<i>Cannabis sativa.</i>
Lallemantia oil, . . .	<i>Lallemantia iberica.</i>
Linseed oil, . . .	<i>Linum usitatissimum (L. perenne).</i>
Poppy seed oil, . . .	<i>Papaver somniferum ; P. rheas ; Glaucium luteum ; Argemone mexicana.</i>
Tobacco seed oil, . . .	<i>Nicotiana tabacum.</i>
Walnut oil (nut oil), . . .	<i>Juglans regia.</i>
Weldseed oil, . . .	<i>Reseda luteola.</i>

Many other oils of pretty strongly marked drying qualities are known and employed locally, without being articles in which any considerable amount of export trade is done ; few of these have been submitted to any detailed examination. Hickory nut oil (*Carya olivæformis*) is sometimes sold under the name of "American walnut oil," but appears to be very inferior in drying qualities. The seeds of *Calophyllum inophyllum*, a forest tree widely distributed in the eastern tropics, furnish an oil known by various names (dilo, domba, pinnay, poon seed, or tamanu oil) ; when mixed with pigments, this forms a paint that dries in 12 hours, without any previous boiling ; owing to the large yield of oil, and the plentifulness of the tree in India, Ceylon, the Malay Archipelago and Java, and the South Pacific Islands, &c., this oil appears likely to be an important article in future. The kernels of the *Aleurites cordata (Elaeococca vernicia)* furnish an oil ("Japanese wood oil," "tung oil") largely used as a varnish in China and Japan on account of its extremely rapid drying qualities. According to Cloez, this oil contains about 25 per cent. of olein, and 75 of a homologue of linolin, furnishing on saponification elœomargaric acid, $C_{17}H_{30}O_2$.* Further investigation is desirable, as the qualities of the oil are such as to render it valuable.

* *Comptes rendus*, 83, p. 943.

CLASS VII.—TRAIN, LIVER, AND FISH OILS.

The term "train oil," strictly speaking, applies to any oil extracted from the blubber of cetaceans and allied marine mammalia (such as the seal, porpoise, dolphin, walrus, &c.), and, therefore, in the widest sense includes the sperm oil class, No. X.; but in the present connection it is intended to apply only to those blubber oils that are essentially of glyceridic character, and not to those that mainly consist of compound ethers of monohydric alcohols. It is not quite the equivalent of the German term "thran," which also includes fish oils (sardine oil, menhaden oil, &c.) as well as liver oils (cod liver oil, sunfish liver oil, &c.)

Oils of this class have been much less thoroughly examined as to their chemical constitution than their importance as trade products warrants. In some cases they consist mainly of the glyceride of *physetoleic acid*, a lower homologue of oleic acid; but other glycerides are generally present as well, preventing the formation of solid elaidins; soft products from which liquid matter separates on standing are generally formed, much as with the oils of Classes II. and VI.; from which circumstance, together with the high iodine number generally indicated, and the possession of some degree of drying qualities, it appears probable that drying oil glycerides are also present. Liver oils (cod and shark's livers, &c.) generally contain perceptible amounts of cholesterol and allied biliary products; like fish oils proper (*e.g.*, menhaden oil), they evolve large amounts of heat on admixture with sulphuric acid, resembling the vegetable drying oils in this respect; whilst train oils (whale oil, seal oil, &c.) give a somewhat lower degree of heat evolution, probably on account of the presence of notable amounts of the glycerides of solid fatty acids (stearin, &c.) When oils of this class are separated from the nitrogenous tissues immediately, so that no decomposition takes place, they are comparatively inodorous and tasteless, and contain no appreciable quantity of free fatty acids; but if the livers, blubber, fish, &c., are kept for any length of time before the oil is extracted, a more or less strongly marked animal fishy smell is developed, becoming excessively rank in extreme cases; as in the case of rancid vegetable oils, more or less hydrolysis of glycerides with production of free fatty acids, appears to accompany the development of the strong-smelling bye products thus formed.

The distinction between oils of this class (mainly glyceridic in character) and those of Class X. (mainly non-glyceridic) is in actual practice not extremely sharply marked; for sperm oils usually contain small quantities of glycerides, although the chief constituents are non-glyceridic compound ethers; whilst on the other hand, some of the blubber oils contain notable amounts of solid non-glyceridic compound ethers (spermaceti), deposited on

cooling and standing. In fact, it is as difficult or impossible to draw a hard and fast line of demarcation between the glyceridic and non-glyceridic animal oils, as it is between the drying and non-drying vegetable oils; and for the same reason, viz., that whilst the two extremes are tolerably sharply contrasted in general composition, yet various intermediates exist, partaking of the character of both classes. To some extent, this may possibly arise from the circumstance, that when a ship is engaged in oil-fishery, it is not always practicable to keep apart the blubbers obtained from different species, so that the oil ultimately extracted is often a mixture of the products obtained from different kinds of animal, each of which, if examined separately, would exhibit special characteristics analogous to those distinguishing different seed oils. In general, it appears that whalebone-yielding whales* (*Balænoidea*) furnish oils containing little or no monohydric compound ethers like spermaceti; whilst toothed whales (*Delphinoidea*) yield oil where these substances are usually present, in some cases as chief constituents; these latter form the oils of Class X.

The chief oils of this class are the following:—

Name of Oil.	Sources.
Train Oils— Dolphin and Porpoise oils,	<i>Delphinus phocæna</i> (<i>Phocæna communis</i>), or common porpoise. <i>P. orca</i> , or grampus. <i>Delphinus delphis</i> , or common dolphin. <i>Delphinus globiceps</i> . <i>D. tursio</i> . <i>Monodon monoceros</i> , or narwhal.
Seal oils,	<i>Phoca vitulina</i> ; <i>P. grælandica</i> ; <i>P. barbata</i> ; <i>P. annelata</i> ; <i>P. lagura</i> ; <i>P. sjetida</i> ; <i>P. caspica</i> ; <i>P. proboscidea</i> . <i>Otaria jubata</i> . <i>O. australis</i> .
Walrus oil, (morse oil, dugong oil, manatee oil).	<i>Trichechus rosmarus</i> , morse or walrus. <i>Halicore australis</i> and <i>H. indicus</i> , or dugong. <i>Manatus australis</i> and <i>M. americanus</i> , or manatee.
Whale oils and Blackfish oils.	<i>Balænus mysticetus</i> or <i>B. grælandicus</i> , the "right whale." <i>B. glacialis</i> , or polar whale. <i>B. bœops</i> , or humpbacked whale. <i>B. antarctica</i> , or cape whale. <i>B. australis</i> , or southern black whale. <i>Balænoptera gibbar</i> , or finner whale. <i>Globiocephalus intermedius</i> , or pilot whale. <i>G. macrohynchus</i> , or killer. <i>Beluga catodon</i> , or white whale.

* Huxley classes the existing cetacea (exclusive of extinct genera) as *Balænoidea* and *Delphinoidea*, the latter group including *Platinistidæ*, *Delphinidæ* (dolphins, porpoises, grampus, and narwhal) and *Physeteridæ*; these last being further subdivided into *Physeterina* (cachelots or sperm whales) and *Rhyncoceti* (bottlenose whales).

Name of Oil.	Sources.
Liver Oils— Cod oils,	<i>Gadus morrhua</i> (<i>Asellus major</i>). <i>G. cellarius</i> . <i>G. molva</i> (<i>Molva vulgaris</i>). <i>G. aeglefinus</i> . <i>G. carbonarius</i> (<i>Merlangus carbonarius</i>). <i>G. merlangus</i> (<i>Merlangus vulgaris</i>). <i>G. pollachius</i> (<i>Merlangus pollachius</i>). <i>Merluccius communis</i> .
Malabar oils,	<i>Rhyncobatus pectinata</i> . <i>R. levis</i> . <i>Gali-</i> <i>cerda tigrina</i> . <i>Carcharias melanopterus</i> .
Ray and Shark oils,	<i>Raja clavata</i> . <i>R. batis</i> . <i>Trigon pastinaca</i> . <i>Squalus carcharias</i> , or common shark. <i>S. maxima</i> , or basking shark. <i>S. glacialis</i> , or Greenland shark. <i>S. zygaena</i> (<i>Zygaena</i> <i>malleus</i>), or hammerfish. <i>S. acanthius</i> , or picked dogfish. <i>S. spinax niger</i> , or kulp.
Fish Oils— Herring oils, (sardine, sprat, pilchard, anchovy, louar, &c.)	<i>Clupea pontica</i> (Astrakan herring). <i>C. sardinus</i> , or sardine; <i>C. neohouri</i> , <i>C.</i> <i>lemuru</i> , and <i>C. palasah</i> , or Indian and Malayan louar. <i>C. sprattus</i> , or sprat. <i>C. pilchardus</i> , or pilchard. <i>Engraulis</i> <i>encrasicholus</i> , or anchovy.
Menhaden oil,	<i>Alosa menhaden</i> (<i>Brevoortia menhaden</i>).
Oolachan oil,	<i>Thaleichthys paciferus osmerus</i> .
Tunny oil,	<i>Thynnus vulgaris</i> .

Schädler gives the following table of colour reactions of seal, whale, liver, and fish oils with strong nitric acid (sp. gr. 1.45); sulphuric acid (sp. gr. 1.6–1.7); and the two mixed in equal proportions (compare p. 153).

Nitric Acid.	Sulphuric Acid.	Mixed Acids.
SEAL OIL— Red brown,	Reddish yellow, becoming reddish brown, and ultimately brownish red, somewhat like blood.	Reddish, becoming brown.
WHALE OIL— Brownish, becoming full brown, and finally black brown.	Brown, becoming black brown.	Yellow, becoming reddish, and finally dirty brown.
LIVER OILS— Blood red, becoming brownish red to brown.	Violet to black violet.	Yellow red, becoming bright red, finally reddish brown with violet streak.
FISH OILS— Brown,	At first greenish, then brown, and finally quite black.	Yellow, then greenish, afterwards brown.

CLASS VIII.—VEGETABLE BUTTERS, FATS AND WAXES, &c.

When the proportion of glycerides of relatively high melting point to olein is large, the physical texture of a substance that would be an oil in the tropics becomes more like that of butter at 15°–20°; concurrently with the change in comparative fluidity the iodine absorption is largely reduced as compared with oils of Classes I. and VI., on account of the diminished proportion of olein present. In the case of certain vegetable glyceridic waxes (e.g., Japanese wax), the olein is reduced to insignificant proportions or to nil, with the result of increasing the relative solidity and considerably raising the melting point. Some of the substances of this class contain a notable proportion of glycerides of acids of the acetic family of sufficiently low molecular weight to be readily volatile with steam at ordinary pressure (e.g., coker-nut and laurel butters and palm kernel fat); others are practically destitute of such ingredients. When subjected to regulated pressure (p. 283) liquid oleines are squeezed out, and solid stearines left, the former closely resembling oils of Classes I. and VI. when sufficiently freed from the latter.

The best known substances of this class are the following:—

Name of Butter, &c.	Sources.
Bassia fat; Illipé butter, Mahwa butter, Phulwara fat (Fulwa fat), Shea butter (Galam butter), &c.	<i>Bassia latifolia</i> (Roxb.) <i>B. longifolia</i> (Linn.) <i>B. butyracea</i> . <i>B. Parkii</i> (<i>Butyrosperma Parkii</i> —Kotschy).
Cacao butter,	<i>Theobroma cacao</i> (Linn.) <i>T. bicolor</i> (Humb.) <i>T. augustifolium</i> (Sessé). <i>T. leiocarpium</i> and <i>T. pentagonum</i> (Bern.) <i>T. microcarpum</i> (Mart.)
Chinese tallow,	<i>Stillingia sebifera</i> (<i>Croton sebiferum</i> , Linn.)
Cokernut butter (copra butter or copra fat).	<i>Cocos nucifera</i> ; <i>C. butyracea</i> .
Cotton seed stearine,	Cotton seed oil by chilling and pressing.
Dika fat,	<i>Irvingia barteri</i> (Hock.) <i>Mangifera gabonensis</i> (Aubry Le Comte).
Japanese wax,	<i>Rhus succedanea</i> (Linn.); <i>R. acuminata</i> (De C.); <i>R. vernicifera</i> (De C.); <i>R. juglandifolia</i> (Don). <i>R. sylvestris</i> (Siebold).
Malabar tallow (Piney-tallow).	<i>Vateria indica</i> (Linn.); <i>V. malabarica</i> (Blum.); <i>Blæocarpus copaliferus</i> (Retz.)
Myrtle wax,	<i>Myrica cerifera</i> , and several other species of myrtle.
Myristica butters (Nutmeg butter, Virola tallow, Otoba wax, Ucuba or ocuba wax, &c.)	<i>Myristica officinalis</i> (Linn.); <i>M. moschata</i> (Thumb.); <i>M. sebifera</i> (<i>Virola sebifera</i>); <i>M. otoba</i> (Humb. and B.); <i>M. ocuba</i> (<i>M. ucuba</i> , <i>M. bicuhyba</i>); <i>M. malabarica</i> .
Palm butter (palm oil). Palmnut butter (palm kernel oil). }	<i>Elais guineensis</i> (Jacq.); <i>E. melanococca</i> (Gaert.); <i>Alfonsia oleifera</i> (Humb.)

Similar solid or semisolid vegetable fats are also furnished by the following trees and plants:—

Nephelium lappaceum (Linn.); indigenous to Sunda Island, Malacca, and some parts of China. The seeds furnish "Rambutan tallow," melting at about 65°, the solid stearine of which is chiefly the glyceride of arachic acid; a little olein is also present (Oudemans).

Carapa guyanensis (*C. guineensis*) and *C. indica* (or *C. moluccensis*); found in Brazil, Guiana, Guinea, Sierra Leone, India, Ceylon, &c. The seeds of these two species furnish "Carapa fat" (otherwise designated "Andiroba fat," "Coundi oil," "Crabwood oil," "Touloucoona oil," &c.), possessing a composition akin to that of palm oil—*i.e.*, consisting chiefly of the glycerides of palmitic and oleic acid. It usually possesses a sickly persistent odour almost impossible to get rid of. The coloured natives use it largely as an unguent and insectifuge for the head, its properties in this respect being apparently due to an admixed bitter principle termed *carapin*.

Mafureira oleifera (Bert.) or *Trichelia emetica* (Vahl.) This tree grows in Mozambique, and about Zambesi and the White Nile; by crushing the seeds and boiling with water a fat known as "Mafura tallow" is obtained, much resembling cacao butter, melting at 42°, and chiefly consisting of palmitin and olein.

Calophyllum inophyllum (Linn.), indigenous to India and the Malay Archipelago, and *C. calaba*, found in the Antilles, yield respectively "Poon fat" ("poon seed oil") or "Tacamahac fat") and "Calabar oil." The former is also known by various other names (*vide p.* 291).

Laurus nobilis, found largely in Southern Europe and Asia, yields "laurel butter" ("bayberry fat"), largely consisting of the glyceride of lauric acid, along with a little myristin and other homologues, and some olein. A similar product is obtained from *L. persea* (Linn.) or *Persea gratissima* (Gaert.), the Alligator pear tree of Brazil and the West Indies; known as "Alligator pear oil," "Persea fat," and "Avocado oil."

In addition to these, a large number of more or less hard vegetable fats and tallows are obtainable from other sources, concerning the chemical constitution of which little or nothing is known; thus "Malayan tallow" and "Borneo tallow" are solid fats obtained from the nuts of various species of *Hopea* in Java, Sumatra, and Borneo. An analogous product, "Sierra Leone butter," is obtained in Sierra Leone from *Pentadesma butyracea*. "Goa butter" ("Kokum butter" or "Mangosteen oil") is a similar fat obtained in the East Indies from the seeds of *Garcinia indica* (*Mangosteena indica*). The allied species *G. pictoria* or gamboge tree furnishes "gamboge butter." The seeds of *Pongamia glabra*, another East Indian shrub, furnish "Korinje (Karanja) butter," "Poondi oil" or "Ponga oil," some-

what more readily fusible than most of the vegetable fats and tallows. "Macaja butter" is derived from the edible fruit of *Cocos aculeata* (*Acromia sclerocarpa*, Mart.; *Bactris minor*, Gaert.), indigenous to Brazil, Guiana, and the West Indies. In Java a fat much resembling coker butter, "tangkallak fat," is derived from the *Cylicodaphne sebifera*. Semisolid fats are obtained from the *Canarium commune* of the Moluccas and Malabar ("Canary oil," "Java almond oil") and the butternut tree of the Brazils (*Rhizobolus butyrosa*; the allied species, *R. amygdalifera* (*Caryocar brasiliensis*) and *Caryocar tomentosum*, respectively furnish "Caryocar oil" and "Sawarri (or Souari) nut butter." The soap tree of Bengal, Southern India, and the West Indies (*Sapindus emarginatus*, Roxb.; *S. trifoliatius*, Linn.; *S. laurifolia*, Vahl.), furnishes a fruit rich in saponin, and also yielding a semisolid fat. "Maccassar oil" is a semisolid fat obtained from the seeds of *Schleichera trijuga*;* and "Piquia oil" ("Pekea fat") is a similar product from *Pekea butyrosa* and *P. ternatea*, found in Guiana and the Antilles. *Melia azedarach* (Linn.), the "pater-noster tree" of Syria, Northern India, and the Deccan, &c. (so-called from the employment of its stones in Italy and elsewhere for making rosaries), also known as *Melia indica* (Brand.) and *Azadirachta indica* (Juss.), furnishes a very similar semisolid fat, known as "Zedrach oil," "Margosa oil," "Veppam fat," or "Nimb (or Neem) oil." "Niam fat" is derived from the *Lophira alata*, found in Eastern and Western Africa. "Chaulmoogra oil" is a soft fat fusing at about 17° C., obtained from the seeds of *Gynocardia odorata* (*Chaulmoogra odorata*), much used in India, China, and elsewhere for medicinal application to the skin. "Soudan butter" is a soft fat obtained by boiling with water the seeds of *Vitellaria paradoxa*, or Soudanese butter plant; a similar product is obtained in Cochin China and Japan from the seeds of *Sebifera glutinosa* (*Tetranthera laurifolia*, Jacq.) The seeds of *Ænocarpus bacaba* and *Æ. patawa*, of Central America, yield by similar treatment a soft fat known locally as "Comou butter." "Para butter" or "Assai oil" is similarly obtained from the Assai palm (*Euterpe oleracea*), common in Brazil and the neighbourhood of Para. "Chequito" is a fatty substance obtained by the Kaffirs of Southeast Africa from the "butter tree," *Combretum butyraceum*. The seeds of *Cocculus indicus* contain a solid fat, extracted and used by the natives in India, but apparently not yet known commercially; similar products are obtained from the fruit kernels of *Lucuma bonplandi* in Mexico, and the Ochoco (*Dryobalanops*) of Guinea.

* Also from the oleaginous fruit of *Stadmannia* (*Cupania*) *Sideroxylon*, growing in Sunda and Timor Islands, and from the seeds of the safflower (*Carthamus tinctorius*); other varieties of so-called "Macassar" oil are simply more or less fluid oils in which odorous flowers, &c., have been digested so as to scent them.

In addition to the above, a large number of other sources of vegetable fats exist in different parts of the world, the knowledge of which is as yet chiefly confined to the natives; there can, however, be little doubt that in due time, as civilisation advances and opportunities for export and manufacture become more frequent, many of these little-known products will be found to be of considerable value as sources of oleaginous material.

CLASS IX.—ANIMAL FATS—TALLOW, LARD, AND BUTTER CLASS.

Almost every known animal is capable of yielding more or less considerable amounts of fatty matter by appropriate treatment; but in practice, comparatively few are actually employed as sources of fat, apart from their consumption as food. The solid fat of oxen and sheep (known as *tallow* or *suet* when derived from the adipose tissues of the body), the grease extracted from their hoofs (*neat's foot oil*, *sheep's trotter oil*), and that obtained by boiling the bones (*bone grease*) are closely akin in general composition, except that the latter are softer in character, chiefly because containing a larger proportion of olein, and a smaller amount of solid glycerides. The fatty matters (butters) contained in the milk of cows and ewes, on the other hand, have a composition materially different from that of the fats present in the adipose tissues of the body; and the same remark applies to the milk fats of all other mammalia, so far as they have been examined. In general, the milk fats of various animals do not differ very greatly in character; thus, the butters derived from the cow, ass, ewe, goat, elephant, hippopotamus, sow, mare, and woman, appear to be as closely akin as are the more or less solid tallows, greases, and suets obtainable from the body tissues of these various animals; but whilst the latter fats are all essentially mixtures of the liquid glyceride of oleic acid, and the solid glycerides of stearic and palmitic acids (the liquid constituents being present in larger quantity in the softer fats, like lard), the former fats contain a considerable amount of the glycerides of acids, also of the stearic series, but of much lower molecular weight than palmitic acid. Similarly, the milk fat of the whale is not widely different from that of the cow, although the oil of whales' blubber differs much from suet in composition.

The fats obtained from the carcasses of birds (goose grease, turkey fat, pheasant grease, &c.) appear to be substantially similar to the softer body fats of mammalia in general composition, essentially consisting of olein, with enough stearin and palmitin to render them semisolid at the ordinary temperature; the oleaginous matter contained in eggs (*e.g.*, hen's eggs) is softer

still, and consists of olein and palmitin, together with other substances foreign to the oil proper (*vide* p. 121).

Various reptiles (turtles, crocodiles, &c.) are utilised in different parts of the world as sources of oleaginous matters, apparently, for the most part, closely akin to the fats of the mammalian vertebrates; on the other hand, the oily matters derived from fish are differently constituted (*supra*, p. 292).

The following list includes the more important solid or semi-solid animal fats, apart from those derived from fishes and cetacea:—

Name of Fat.	Sources.
Bone fat,	Bones of oxen and horses, &c., extracted by boiling or by solvents.
Butter (cow's milk fat),	Domestic cow.
Butter substitutes (butterine, margarine, oleomargarine),	The softer portions of the fat of oxen and sheep, &c., separated by special processes.
Crocodile fat (alligator fat),	Indian crocodile and common alligator (<i>Alligator lucius</i>).
Egg oil,	Yolks of hen's eggs (<i>Gallus domesticus</i>).
Goose grease,	Common goose.
Horse grease (mare's grease),	Horse carcasses (<i>Equus caballus</i>).
Lard,	Common hog.
Tallow,	Ox, sheep, goat, &c.
Tannery grease, kitchen grease, wool grease,	Animal greases from various kinds of trade refuse.

In addition to these, the fat of the alpaca is used to a considerable extent in some parts of South America; that of the dog in continental Europe, that of the hippopotamus in Africa, and that of the turtle in the islands of the South Pacific, Brazil, and along the South American coast. The last is sufficiently fluid in a tropical or subtropical climate to be used as a burning oil. Bear's grease was at one time highly esteemed as a pomade, but is now mostly superseded by other forms of clarified fat. Many other animal fats are also used locally in different countries to a greater or lesser extent, but as yet are not articles of regular trade. When the solid or semisolid fats of this class are subjected to expression, the liquid animal oleines of Class IV. result—*e.g.*, lard oil, tallow oil, &c.

CLASS X.—ANIMAL OILS—SPERM OIL CLASS.

The blubber oils included in Class VII. (whale, seal, porpoise, &c.) differ from those belonging to this class essentially in that they consist chiefly of fatty glycerides; whereas the oils now under consideration, whilst not invariably free from glyceridic con-

stituents, have, as regards their leading constituents, an entirely different composition, these substances being compound ethers formed from monohydric alcohols and fatty acids, analogous to ethyl acetate and similar substances. In general, two kinds of such compound ethers appear to be present simultaneously—one liquid at ordinary temperatures, corresponding with the olein of ordinary vegetable oils, and consisting of ethers of acids of the oleic family; the other solid, corresponding with stearin or palmitin, and consisting of ethers of acids of the acetic family. Just as a vegetable oil on chilling deposits solid matter of the stearin character, readily separable by filtration or straining, so does a blubber oil of the sperm class similarly deposit solid crystallisable matter, generally the substance known as *spermaceti* (mainly consisting of cetyl palmitate); the liquid portions separated from this deposit appear to be mixtures not only of compound ethers of different homologous acids, but also of different homologous alcohols, some of which belong to the ethylic series, whilst others are apparently homologues of acrylic alcohol, capable of combining with iodine, like the unsaturated acids. In consequence, when saponified, these liquid oils yield large percentages of products insoluble in water, but soluble in ether, &c., consisting of mixtures of the alcohols formed during saponification; a circumstance sharply distinguishing them from the glyceridic oils of Class VII., which yield only comparatively small quantities of unsaponifiable matters insoluble in water, chiefly consisting of cholesterol and similar substances.

On account of the presence of compound ethers of the oleic family, oils of the sperm class become more or less solidified by nitrous acid in virtue of the elaidin reaction; with Maumene's test (p. 147) they develop but little more heat than olive oil, being thus sharply distinguished from most fish oils of Class VII., which give a much greater heat evolution (pp. 149, 150). Their peculiar compound ether composition largely raises the saponification equivalent.

The physical characters of this class of oils also are peculiar in virtue of their unusual constitution; thus their efflux viscosity (p. 101) is much less influenced by variation of temperature than is the case with most other oils, whence their value as lubricants for special purposes. Their specific gravity is low, usually considerably below .900, near .880.

The principal oils of this class are as follows:—

Name of Oil.	Sources.
Sperm oil,	<i>Physeter macrocephalus</i> , L. (Cachelot whale).
Doegling oil (Arctic sperm oil or true bottlenose oil),	<i>Hyperoodon rostratus</i> (<i>Balæna rostrata</i>), or true bottlenose whale, <i>H. Bidens</i> .

Various other toothed cetaceans also furnish oils containing spermaceti in sufficient quantity to separate out in the solid state on chilling and standing, more especially the oil from the bottlenose dolphin, *Delphinus globiceps*, which appears to be essentially intermediate in character between the almost wholly glyceridic and largely valerine-containing oil from the common porpoise, and the mainly compound ethereal sperm oil of the cachelot in which only small amounts of valerine are present.

CLASS XI.—VEGETABLE NONGLYCERIDIC WAXES.

Several species of plants are known, the berries, leaves, stalks, &c., of which are naturally covered with a waxy exudation closely akin in its origin to certain of the more solid vegetable fats, but differing therefrom in being essentially nonglyceridic in character. Of these substances the principal are as follows:—

Name of Wax.	Source.
Carnauba wax, . . .	<i>Corypha cerifera</i> (Linn.); <i>Copernicia cerifera</i> (Mart.)
Cowtree wax, . . .	<i>Galactodendron americanum</i> (Linn.); (<i>G. utile</i> , Kunth; <i>Brosimum galactodendron</i> , Don.)

In addition very similar products are obtained from several other sources—e.g., *Petha wax*, from the bloom on the Indian white gourd (*Benincasa cerifera*); *Fig wax* (Getah wax), prepared in Java and Sumatra from *Ficus umbellata* and *F. cerifera* (Blume); *Palm wax* (Ceroxylin), largely used in Brazil, from the common wax palm, *Ceroxylon andicola* (Humb.), and the Klopstock palm, *Klopstockia cerifera* (Karsten); and *Cordillera wax* from the Cordillera waxtree (*Elæagia utilis*).

These products, however, do not seem to have been submitted as yet to full chemical investigation, so that it is not certain whether they are true vegetable waxes of nonglyceridic character, or simply vegetable fats of waxy texture analogous to so-called Japanese wax. Comparatively little of these various kinds of vegetable waxes is as yet exported to Europe, most being used for candlemaking, &c., in the countries where they are indigenous.

CLASS XII.—BEESWAX AND SPERMACETI CLASS.

The nonglyceridic waxlike compound ethers of animal origin used to any extent industrially are but few in number, the principal being as follows:—

Name of Wax.	Source.
Beeswax (ordinary beeswax. Andaquia wax, Antilles wax, African beeswax, Abyssinian beeswax, &c.),	<i>Apis mellifera</i> , or common bee. Numerous allied species exist, many of which are also wax producers—e.g., <i>Apis fasciata</i> (<i>Melipona fasciata</i>), or South American bee; <i>Apis unicolor</i> , or Madagascan bee; <i>Apis dorsata</i> , of the Eastern Archipelago. The common wasp and other allied genera are also wax producers to a limited extent.
Chinese wax (Peh-la or Pela),	<i>Coccus sinensis</i> (<i>Coccus pe-la</i> , <i>C. chinensis</i>).
Indian wax (Arjun wax),	<i>Ceroplastes ceriferus</i> .
Niin fat,	<i>Coccus adiposera</i> .
Spermaceti,	<i>Physeter macrocephalus</i> .
Woolgrease,	Natural grease (inspissated perspiration) of the common sheep.

CHAPTER XIV.

PRINCIPAL USES OF OILS AND FATS, &c.

THE classification described in the previous chapter is mainly based on the physical and chemical characters of the natural fixed oils and allied substances; from the point of view of their leading practical uses they may be conveniently considered under one or other of the following six heads:—

1. Substances used for edible purposes, including cooking and preservation of food (e.g., sardines).
2. Fluid oils employed for burning in lamps or otherwise.
3. Substances furnishing solid materials for candlemaking.
4. Substances used in the manufacture of soap.
5. Drying oils employed for paint manufacture and in the preparation of varnishes, linoleum, and such like products.
6. Substances used for miscellaneous purposes; more especially as lubricants or ingredients in lubricating mixtures; for currying leather, dressing cloth and textile fabrics, and similar purposes; as oil baths for tempering metals; as solvents for odorous matters in the process of *enfleurage* in perfumery manufacture; for the preparation of unguents, pomades, cosmetics, &c.; in the manufacture of sealing wax and analogous compositions; and for numerous minor uses in the arts generally.

Of these six groups, Nos. 3 and 4 are separately considered in § 6 and § 7 (candle and soapmaking, including glycerol extraction); with respect to the other uses, some few points are of special interest from the technological point of view, in connection with which the question of purity and freedom from adulteration with inferior materials is frequently of prime importance.

EDIBLE AND CULINARY USES OF OILS,
FATS, &c.

Fatty matters of various kinds are ingredients in most kinds of food stuffs in common use to a greater or lesser extent; thus apart from suet and the adipose tissues interleaved with the "lean" of most kinds of animal meat, most vegetable seeds, nuts, and other edible produce contain more or less considerable quantities of oleaginous matter; sometimes to an extent sufficiently large to admit of oil being extracted by pressure (*e.g.*, olives, walnuts, hazelnuts, &c.), sometimes only in smaller quantity, so that a solvent (ether, &c.) is requisite before the presence of oil can be demonstrated. When thus treated, however, even such substances as wheaten flour and cereal produce generally, rice, and dried vegetables can be shown to contain small quantities of oleaginous ingredients.

Apart from the consumption of oily matter for food in forms such as these, large quantities of separately extracted fatty substances are habitually used as edibles by both civilised and uncivilised races—*e.g.*, "salad" oils employed for "dressing" raw vegetables and otherwise as food materials; more or less purified and rendered animal fats, especially dripping and lard; and the fatty matter of cow's milk (butter). In cold climates seal and whale oil are eagerly partaken of by the natives as heat-generating foods, whilst a lump of tallow is a delicacy; elsewhere fish preserved in oil (*e.g.*, sardines), or cooked in hot oil, pastry containing butter, suet puddings, and numberless other viands into the composition of which more or less oleaginous matter enters, are everyday articles of diet.

With the exception of actively medicinal oils (such as *croton* and *castor oils*), the great bulk of natural glycerides are suitable as food material for cattle, especially when used without separation from the other vegetable matters naturally accompanying them. *Linseed cake* (crushed linseed subjected to pressure so as to express most of the oil), and similar substances from other kinds of seeds, &c., are well known cattle foods, the value of which largely depends on the amount of residual oily matter left in the mass.

Waxes, on the other hand, are but little adapted for nutritive purposes; thus beeswax (even when eaten along with honey) mostly passes unchanged through the alimentary canal, and is not assimilated at all, either by human beings or other mammalia.

In the preparation for table and culinary use of oils and fats, &c., but little treatment of a technical nature is usually requisite, the chief points requiring attention being good quality of the raw material, and cleanliness in the treatment to which it is subjected; thus the excellence of the butter prepared in a given dairy chiefly depends on the quality of the milk from which it is separated, and the care and cleanliness employed throughout the

process. Very similar remarks apply to the preparation of the finer qualities of refined lard intended for food, and the ordinary kitchen operations of clarifying dripping, &c., and to the extraction of vegetable oils generally. As already described, "virgin" oils, and "first runnings" are generally prepared from choice oil sources (olives, arachis nuts, &c.) by gentle pressure without heat, somewhat coarser grades being subsequently expressed by stronger pressure and heat combined; refining by agitation with water, subsidence, and straining, being usually preferred to processes involving chemical treatment. In some parts of Russia and Eastern Europe much coarser oils are consumed by the peasantry than are usually similarly employed amongst either Western Nations or Asiatics; hempseed, poppy seed, and linseed oils, often somewhat crudely extracted, being largely used as cooking oils. Of late years, however, sunflower seed oil has to a great extent superseded these coarser oils; whilst in Western Europe, America, and many other parts of the world, cotton seed oil, expressed by the hydraulic process described in Chap. IX., and subsequently refined by boiling with alkalis, &c., is now very largely employed for many purposes for which formerly only olive oil was used, or the better grades of arachis oil, sesamé oil, and similar high-class substances; the result of properly refining a fair quality of raw cotton seed oil being to produce a light coloured pleasantly tasting wholesome product eminently well adapted for frying fish and such like cooking operations. In connection with this the following table by Grimshaw is of interest, showing the way in which a ton of seeds is practically utilised:—

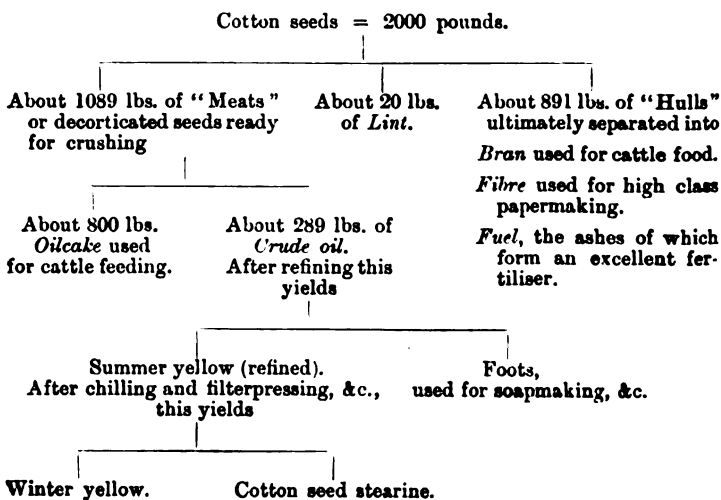

Cotton Seed Stearine (Vegetable Margarine).—When cotton seed oil is chilled, a portion solidifies as solid glycerides; when these are separated by “bagging” or the use of a filterpress (p. 229), and subsequently subjected to hydraulic pressure, a completely solid fat results. The more solid substances thus obtained are largely used as ingredients in artificial butter; the physical characters, and especially the melting point, vary somewhat with the extent to which the expression has been carried; usually cotton seed stearine is pressed so as to melt at a little above 30°.

Amongst the Hindoos and others whose religious beliefs preclude the use of animal fats for edible and cooking purposes, a large sale now exists for purely vegetable fats of buttery consistence (vegetable lard); the process of semisolid stearine extraction from vegetable oils (such as cotton seed, cokernut, and many other native oils) is consequently somewhat largely adopted for the purpose of meeting this demand; quite irrespective of the illegitimate use of these products for purely adulterative purposes in reference to more highly priced animal fats, especially butter and lard.

Another substance, improperly called cotton seed stearine, is obtained by distilling with superheated steam the mixture of organic acids formed when a mineral acid is made to decompose the “foots” obtained during the process of refining cotton seed oil by alkalies (p. 261), and pressing out the “oleine” from the distillate after cooling and solidification. Products of this kind appear to contain a large amount of unsaturated solid fatty acids, possibly isoleic acid (p. 29). A. H. Allen found that a “stearine” of this kind had the specific gravity 0·868 at 99°, and melted at 40°, whilst the iodine number was 89·9; the theoretical value for pure isoleic (oleic) acid being 90·1.

Recent Cultivation of Sunflower Seeds in Russia.—Of late years the oil obtained in Russia from sunflower seeds has very largely displaced the other cooking and table oils (chiefly poppy and hemp) in popular estimation, and the cultivation of the plant has increased enormously; with due care in the drying and cleaning of the seeds, the oil first expressed is equal to the best French table oils in colour, flavour, and taste. The shells form a considerable article of trade for heating purposes, whilst the stalks, dried in piles, are preferred even to pine wood for producing a quick and hot-flame fire; each acre yields about 2,000 lbs. of such firewood and some 1,350 lbs. of oil. The ashes contain much potash; 1,000 lbs. of dried stalks yield 57·2 of ash, from which about 35 per cent. of the best potashes are obtainable. The oilcakes are looked upon as the best in Russia; superior to either hemp or rape seed cake; upwards of 2,000,000 lbs. are exported by the Government of Saratov alone. The seed cups are used as food for sheep. In the larger mills the process of extraction is much the same as that used in England

for linseed and rape seed (Chap. XI.), the shelled seeds being dusted and crushed to a paste in a steam heated vessel; the warm paste is wrapped in camel's hair webbing, and pressed. Out of 104 oil mills in Russia, 85 are employed solely in obtaining sunflower oil, steam being used in 24, and manual labour only in the others (*Journ. Soc. of Arts*, March 18, 1892).

Manufacture of Lard.—The fatty tissues of the hog when properly rendered furnish a white semisolid grease considerably softer than the corresponding fat (tallow) from oxen and sheep, chiefly differing therefrom in containing more olein and less solid glycerides. In most of the larger American hog slaughtering factories the fats from different parts of the body are kept separate from one another, each being treated in a steam rendering pan reserved for that kind only; so that different grades are obtained of considerable constancy of character. The fat from the vicinity of the kidneys, and the "leaf" fat from underneath the skin furnish a superior and harder lard; whilst the fats from tainted carcasses and diseased hogs, being generally melted down all together, produce the lowest grade. The finest qualities are usually put up in bladders, and the other sorts in kegs, whence the terms "bladder lard" and "keg lard" are respectively applied. Bladder lard, when pure, fuses at 42° to 45°; keg lard at 28° to 38°, according to its quality (Allen). The particular texture exhibited by any given example depends largely on the way in which the cooling and solidification of the fused fat was effected, the texture being rendered firmer by stirring during solidification, or subsequent chilling in a refrigerating chamber. Sometimes water, salt, and a variety of other weightgiving adulterants (such as Iceland moss and starch) are stirred in for the purpose of increasing the solidity of the mass. Sodium carbonate solution thus admixed whitens the fat, and enables it to hold a larger proportion of water. The chief sophistication of American lard consists in subjecting the pure lard to pressure so as to express "lard oil" (p. 231), and then working up the residue with cotton seed or other cheap oil so as ultimately to obtain a mass of the proper consistency and texture; beef suet, mutton tallow, and other fatty matters being often also introduced. A test at one time much relied on for the detection of cotton seed oil in such mixtures was Becchi's silver nitrate test (variously modified by different chemists*), depending on the reduction by some constituent of cotton seed oil of silver from silver nitrate, with the formation of a brown mass in a way not observed with other fats, &c.; but latterly it has been found that by thoroughly refining or otherwise treating the cotton seed oil this constituent is mostly either removed or altered, so that the presence of that oil is no longer indicated with certainty by silver nitrate. Sesamé oil, cokernut butter,

*Vide *Analyst*, 1887, 170; 1888, 95, 161, *et seq.*

and similar materials are also used as admixtures, generally along with more or less harder fat, especially "beef stearine."

According to A. H. Allen the presence of any considerable quantity of cotton seed stearine or coker butter may be detected by the effect produced on the relative density, melting point, saponification equivalent, and iodine number, as indicated by the following table:—

	Lard.	Cokernut Butter.	Cotton Seed Stearine.
Specific gravity at $\frac{98.5}{15.5}$, *	·860-·861	·868-·874	...
Specific gravity at 37.8 } (= 100° F.), †	·905-·907	·910-·916	·911-·912
Melting point, . . . }	33°-45°	20°-28°	32°
Saponification equivalent,	286°-292°	209°-228°	285°-294°
Iodine number, . . .	59-62	9	...

The percentage of water present is determined as described on p. 122; substances insoluble in ether (starch, limesoap, &c.) as indicated on p. 123. Mineral nonvolatile matters (lime, salt, alum, &c.) may be found by incineration; soluble substances (salt, alum, &c.) by agitating thoroughly with hot water and separating the aqueous solution for further examination.

Pure unadulterated lard has, according to various authorities, the total acid number 192-197, corresponding with the saponification equivalent 285-292, averaging about 289, whence the mean equivalent of the fatty acids is about 277 (p. 165); the average value directly found is near 278. The iodine number has been found to lie between 50 and 64, indicating about two-thirds olein and one-third palmitin and stearin as the essential composition. Traces of unsaponifiable matters (0.2-0.3 per cent.) are also generally present. When perfectly fresh, lard contains only minute quantities of free fatty acids, less than 1 per cent.; larger amounts are usually found in stale or partly rancid lard.

When chilled to 0 and pressed, lard furnished a solid stearine (sometimes known as *solar stearine*) and lard oil (p. 231): the examination of the fluid oil thus obtained is often better adapted than that of the original lard for the purpose of detecting adulteration; thus admixture of cotton seed oil largely increases its iodine number, and interferes with the formation of a solid elaidin (p. 137), and similarly in other cases. Still better results are obtained on separating the solid and liquid fatty acids by Muter and Koningh's process and examining the latter apart (Chap. xv.)

Artificial Lard.—This name is sometimes applied to various mixtures of "beef stearine" (*vide infra*) and cotton seed oil, or similar hard fats and vegetable oils, in such proportions as to

* Water at $15.5 = 1$.

† Water also at $37.8 = 1$.

give a product possessing the consistency of genuine lard. These substances are less frequently sold under names clearly indicating their nature than used for admixture in larger or smaller proportions with genuine lard for purposes of sophistication. According to some writers adulterations of this kind are becoming much less common than they were a few years ago; but it is doubtful if any great improvement has really taken place in the trade, as a whole.

Manufacture of Artificial Butter.—Several processes are in use whereby the more fusible portions of fresh animal fatty matters are separated from the more solid constituents, so as to yield a mass of buttery consistence which, when treated with annatto or other harmless vegetable colouring matter, and churned up with milk or otherwise treated so as to acquire a weak buttery flavour, furnishes a cheap palatable foodstuff. The better kinds of product thus obtained are undeniably valuable additions to the general food supply; but the practice of mixing them with genuine cow's butter and selling the mixture (or the substitute alone) at considerably above its proper value under the name of "butter," is obviously not a desirable one.* Moreover, the inferior kinds of oleomargarine are not invariably of harmless character, as the earlier forms of tapeworm (*cysticerci*) and other entozoa are sometimes present.

The earliest processes are said to date commercially from the Franco-German war, when the scarcity of butter in Paris during the siege led to the utilisation of various other forms of fat (more especially that of horses) and their treatment so as to obtain a softer and more palatable substance. The original *Mège Mouriès* process consists in treating chopped-up adipose tissue with a weak alkaline solution (potassium carbonate) and minced sheep's or hog's stomach at about 45°C., when partial digestion of the albuminous fatty envelopes and cellular tissue is brought about so that the fat separates, being "rendered" completely at the comparatively low temperature used. On cooling and standing the solid glycerides more or less completely separate in a crystalline form, so that by applying pressure in cloths in an ordinary hydraulic press (p. 231) the still liquid portion is squeezed out, whilst a tolerably hard mixture of glycerides is left, valuable for candlemaking. Instead of alkaline potash solution dilute hydrochloric acid is preferred by some, more especially with an addition of calcium phosphate, so as to form phosphoric acid or an acid phosphate of calcium: the digestive action is thus promoted and hastened.

Much of the "bosch," "Dutch butter," "butterine," "margarine," † and "oleomargarine" of the present day is prepared

* In certain of the United States the Legislature requires that oleomargarine must be coloured *pink* in order to prevent its being sold as butter.

† The term "margarine" is an unfortunate survival of a misnomer

by processes analogous to that of Mège Mouries, excepting that the digestive operation is omitted. The sorted adipose tissue (carefully handpicked, and sometimes washed to separate traces of blood and suchlike animal matters, and then finely minced) is subjected to gentle heat; in some cases alone, so that the more fusible constituents liquate away from the rest, the mass being supported in trays on sloping racks in a room kept at a temperature not much exceeding 50°C .; in other cases in tubs in contact with water at about 45° – 48° , when the more fluid matters gradually float up and are withdrawn from time to time. Beef suet is the preferable material, but sheep's fat is also employed; much of the margarine made in America is derived from hog's fat, being in fact a variety of lard from which much of the solid matter has been removed. The partially exhausted tissues left are rendered in the usual way (p. 245), either alone or mixed with other fatty matters, so as to produce a superior quality of tallow: the oleaginous fluid matters that result from the first processes are cooled and kept at about 25° for some time to allow the solid glycerides to crystallise, and the mass is then pressed. The solid pressed residue is generally known as "beef stearine," and is largely used in the manufacture of factitious lard by incorporation with cotton seed or other fluid vegetable oil so as to form a mass of the required physical consistency.

The resulting expressed oil acquires a buttery consistence at the ordinary temperature, but is usually somewhat softer than cow's butter; by thoroughly churning it up with fresh (or, as preferred by some, sour) milk, and a little minced cow's udder, it acquires a slightly firmer consistence and a buttery flavour. If the temperature during pressing has been too high, or if the solid glycerides have not sufficiently thoroughly separated whilst standing, the expressed substance may be too solid, in which case it is admixed with fluid vegetable oil (cotton seed, arachis, sesamé, &c.) The temperature at which the churning is effected

applied to certain fat constituents in earlier days before the chemistry of these substances was well elucidated. By saponifying tallow, lard, and other animal fats, and separating the fatty acids thence ultimately obtained as far as practicable, various substances were got of somewhat different characters in different cases, but mostly consisting of a liquid fatty acid (oleic acid); a solid constituent melting at about 75° , known originally as *margarous acid* (Chevreul), subsequently as *stearic acid*; and another solid product termed *margaric acid*, crystallising in pearly scales (whence the name, from *μάργαρον*, or *μαργυρίτης* = pearl), and melting at a lower temperature, near 60° . This last was long regarded as a single substance indicated by the formula $\text{C}_{17}\text{H}_{34}\text{O}_2$; the glyceride containing it in the original fat was accordingly known as *margarine*. Subsequently, however, it was shown by Heintz that this pearly-scale crystalline substance was a mixture of homologous substances, consisting chiefly of stearic and palmitic acids; and that whilst true margaric acid, $\text{C}_{17}\text{H}_{34}\text{O}_2$, could be produced artificially (p. 21), it was not a product of the saponification of natural fats, and its supposed glyceride, margarine, was not contained therein.

has a good deal of influence on the physical character of the product; preferably the factitious "butter" is withdrawn and quickly chilled, either by running into ice cold water or on to slabs of solid ice, and then made up into "pats" for the market. Annatto, turmeric, saffron, and various other colouring matters (preferably vegetable, but sometimes of coal-tar origin) are used to communicate a yellow tint; sometimes a minute quantity of butyric ether or other special flavouring and odour-giving substance is added. Inferior kinds of so-called margarine are sometimes made by the simple process of working up comparatively hard fats (such as moderately scentless tallow) with fluid vegetable oils, coker butter, lard oil, and similar softer materials; when such mixtures are further incorporated with more or less stale genuine butter and churned up with milk, &c., products are obtained very closely simulating genuine butter of second or third rate quality; they may be made to correspond with actual butter so closely as to pass most of the tests applicable thereto, excepting that a more or less marked increment is observable in the "Hehner number" (p. 166), and a decrement in the Reichert number (p. 173); with in many cases a slight depreciation of the specific gravity.

Margarine and oleomargarine prepared from solid animal fats, without admixture with cokernut oil, possess a higher total acid number than genuine butter—viz., 192 to 199—corresponding with the saponification equivalent 282 to 293 (tripalmitin = 268·7, trioleine = 294·7, tristearin = 296·7); the iodine number is also higher, being usually between 45 and 55; but since methods have been discovered* for removing the characteristic odour of cokernut oil, the deodorised substance can be admixed with animal margarine in such fashion as to bring down both the saponification equivalent and iodine number to close to the figures observed with genuine butter. Moreover, since cokernut and palmtree oils furnish much smaller percentages of insoluble fatty acids, and larger ones of volatile acids than ordinary soft animal fats, their admixture in the mass tends to lower the Hehner number, and raise the Reichert number, thus rendering detection by these tests more difficult.

The following table, based on one given by Schädler,† represents the way in which the fatty matter from an ox is utilised:—

* Schlink's method for removing the volatile and odorous fatty acids, &c., from cokernut oil, consists in treatment with alcohol and animal charcoal, whereby a perfectly white mass is obtained, of the consistency of butter, and of sweet neutral agreeable flavour. A very considerable sale for the product exists, nominally as a "vegetable lard" for cooking purposes (*supra*); practically, however, the material is largely if not mainly employed in sophisticating cow's butter. For a description of tests employed in the examination of butter supposed to be thus adulterated, *vide* F. Jean, *Moniteur Scientifique*, 1890, 36, p. 1116; in abstract, *Journ. Soc. Chem. Ind.*, 1891, p. 275.

† From results obtained in Sarg's factory, Vienna.

An ox yields about 83 kilogrammes of crude fat, from which are obtained, after careful separation of fleshy matters and impurities,

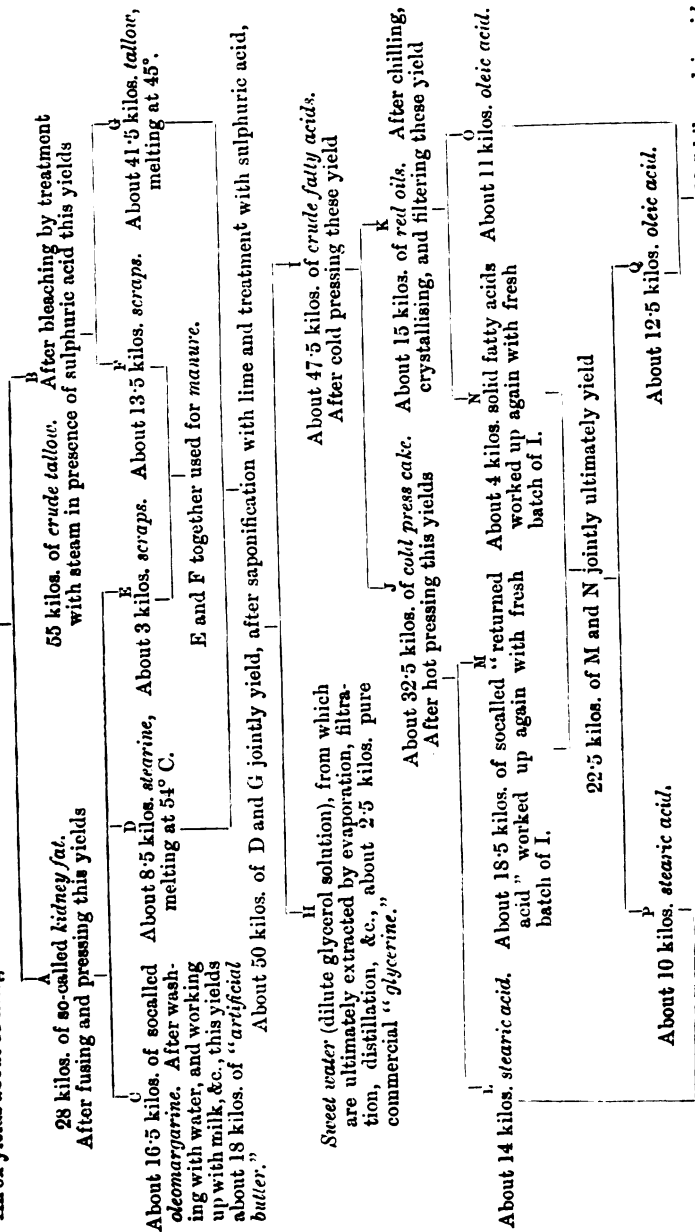

L and P jointly = about 24 kilos. stearic acid.

O and Q jointly = about 23.5 kilos. oleic acid.

FINAL PRODUCTS.

"Artificial butter," about 18 kilos. representing of oleomargarine,	about 16.5 kilos.
Pure commercial "glycerine,"	2.5 "
"Stearine" (stearic and palmitic acids),	24.0 "
"Oleins" (impure oleic acid),	23.5 "
"Scraps" used for manure,	16.5 "
	<hr/>
	83.0
	<hr/>

It would hence seem that a very considerable loss of glycerol accompanies the various processes gone through in the course of the isolation of the pure redistilled commercial article; for 24 kilos. of stearic acid, together with 23.5 of oleic acid, theoretically correspond with about 5.3 kilos. of glycerol instead of 2.5, indicating a total loss of more than 50 per cent. of the glycerol formed during saponification.

LAMP OILS.

From the earliest ages the use of lamps has been general, essentially consisting of a vessel for holding the oily matter, provided with some kind of porous wick up which the oil rises, by capillary action, to supply the place of that burnt in the flame. Probably this arrangement was actually a development of the still earlier torch or flambeau, consisting in its simplest form of a splinter of pine containing natural resin, and in a more elaborate shape of strands of vegetable fibre dipped in resin, asphalt, and similar materials (obviously the prototype of the more modern wickèd candle). The wicks used in some of the early forms of lamp appear to have been of rush-pith, apparently closely akin to the rush-candle or rush-light; saving that in the latter the vegetable wick was dipped in a comparatively solid fat melted by heat, and then taken out and allowed to harden, whilst in the former the wick was held in position by some simple device, and a thinner fat or oil used, fluid enough to moisten the wick without extraneous heat. In the modern "nightlight" both forms are substantially combined, the arrangement being virtually a candle on first lighting, and practically an oil lamp after burning sufficiently long to melt the remainder of the fatty matter by the heat developed.

Amongst the Eastern nations, crude natural naphtha or petroleum has been largely used as a burning oil from time immemorial; but the methods now in use for purifying it and separating it into different fractions (some of which are far better adapted for burning in lamps than the raw material, whilst others are quite unfit for that purpose) are of quite modern origin. Amongst the Greeks and Romans, olive oil appears to have been

largely used for the purpose; whilst rough candles of tallow, and superior ones of wax, were also in use. In all the early forms of household lamp no chimney was employed, so that the flame was invariably more or less smoky, a circumstance which considerably limited the number of vegetable oils available; in 1784, Argand introduced the form of lamp still bearing his name (although greatly altered and improved by subsequent inventors), essentially consisting of a circular wick with an air supply in the centre, a chimney of iron (later of glass) being also applied, so as to increase the draught and so facilitate combustion, thus diminishing smoke and increasing the light emitted.* This invention greatly stimulated the use of oil lamps, and colza oil and sperm oil soon became extensively used for consumption therein, together with many other varieties, notably the oils from rape seed, ground nuts, and cotton seed. At the present day, however, the use of these oils in this way, though by no means inconsiderable, is small as compared with that of the hydrocarbon oils from petroleum and paraffin shale, &c. (at any rate in those countries where the latter are readily obtainable), on account of the greater cost; but in many semicivilised lands the cost of vegetable oils indigenous to the district is often below that of imported petroleum burning oils, so that the mineral oils have in such cases not yet largely supplanted the vegetable ones.

When rape (colza) oil is burnt, a tendency to charring of the wick appears to exist if the oil contain much free fatty acids (formed by decomposition of the original glycerides during extraction and refining, &c.); this is also marked in the case of olive oil. According to Archbutt, 5 per cent. of free fatty acids is the maximum permissible, otherwise a defective light results, and the wick soon chars.

DRYING OILS USED FOR PAINT MANUFACTURE AND IN THE PREPARATION OF VARNISHES, LINOLEUM, AND SUCH LIKE PRODUCTS.

Drying oils, such as linseed oil, in their natural state as obtained by expression and refining (*raw* oils), absorb oxygen from the air and inspissate at much lower rates than are observed after subjecting them to a form of treatment usually spoken of as "boiling," although the term is not strictly correct, inasmuch as the oils do not become converted into vapour capable of recon-

* Flues or chimneys applied to lamps were not wholly unknown to the ancients; thus the lamp (of pure gold), designed by Callimachus about 400 B.C. for the Erechtheum of the Athens Acropolis, was provided with a chimney in the form of an inverted palm tree of bronze. Argand's use of a chimney was also previously suggested by Quinquet (Leopold Field, Cantor Lectures, *Soc. of Arts Journ.*, 1883, pp. 826 and 848).

densation to the original substance as water or alcohol does when boiled, but only become partially decomposed so as to evolve vapours in consequence of incipient destructive distillation (p. 125) or other decomposition, more especially of the glyceridic portion of the molecule, whereby acrolein is formed.

In the older processes for preparing "boiled" oils, this effect was brought about by heat alone; subsequently various substances known as "driers" were added to the oil in small quantity for the purpose of promoting the particular changes in view. In the more modern methods somewhat lower temperatures are mostly employed, whilst the action is accelerated by injecting air into the hot mass, whereby a greater degree of incipient oxidation is effected, the result of which is to render the oil much more prone to oxidise spontaneously by subsequent exposure to air, and hence to "dry" more rapidly.

The nature of the driers used, and the exact methods of manipulation are often supposed to be valuable trade secrets; but the practical result of working secret "rule of thumb" methods of the kind has not always proved commercially successful. Some of the substances used under the name of "driers" (*e.g.*, dried alum, and zinc sulphate) contribute but little, if anything at all, to the drying effect, their action being simply to coagulate remaining mucilage, and aid its subsequent removal by subsidence. Numerous metallic salts and oxides, &c., are, or have been, employed for the purpose; according to the experiments of Livache, the most marked effect in the way of increasing the rate of drying is produced by manganese and lead salts, copper, cobalt, and zinc compounds being much less active, and salts of iron, chromium, and nickel still less so. In actual practice, compounds of lead are those most frequently used, especially litharge, red lead, and lead acetate; the result of which is that the boiled oil finally obtained contains lead in solution as some kind of lead soap (to the formation of which, in the first instance, the action of improving drying qualities is probably due, the lead soap acting as carrier of oxygen); hence, more or less discoloration of paint made with such oil is apt to occur, especially in towns, independently of that brought about by the white lead added to most kinds of paint. This result is avoided by substituting manganese salts, &c., for lead compounds; accordingly, manganese hydroxide, dioxide, borate, oleate, oxalate, and other organic salts are now somewhat largely employed.*

When the drier is added in fine powder, a considerable fraction of it can be recovered, as it settles to the bottom when the oil is allowed to cool and stand; but a portion is taken into solution as metallic soap and permanently retained in the oil. Apparently

* According to N. Clarke (*Journ. Soc. Arts*, Feb. 10, 1893, p. 289), boiled oil prepared with manganese is unsuitable for varnish making, as it produces a bloom on any varnish made with it.

this soap absorbs oxygen from the air, and then in some way parts with it again to the glycerides present; but the precise way in which the carrying action is effected is not thoroughly understood. In some cases, if too large a proportion of metallic soap is formed, the boiled oil produced is deteriorated, probably because the oxidising action then gets carried too far. By the use of the drier in the form of a solution of known strength, any required proportion can be readily introduced; manganese oleate or linolate, or other fatty acid manganese soap, dissolved in oil of turpentine or similar solvent, is accordingly coming into use for the purpose,* more especially for oils intended to mix with zinc white or other pigments of light tint where darkening is desired to be avoided, such as is liable to be produced in lead-containing oil by the action of sulphur compounds in the air. Moreover, oils "boiled" with manganese driers are generally of a lighter colour than when lead is used. Occasionally, to meet trade prejudices as regards colour, a mixture of lead and manganese compounds is used, so that the darker red tint produced by the lead may be developed to an extent proportionate to the quantity of lead employed.

The proportion of driers employed is usually but small, not exceeding 0.25 to 0.75 per cent. of the weight of the oil (a few lbs. per ton); when used in the solid form it is important that they should be in the finest possible state of division, for which purpose they are usually subjected to a process of levigation after continued grinding; finally, they are ground with oil, much as paint is ground, so as to form a mixture that can be readily disseminated through the mass of oil treated by means of agitators.

In the older method of "boiling," the oil is simply heated along with the driers for some hours to a temperature varying from 200° to 250° C., free fire being used as the heating agent. Fig. 76 represents the kind of arrangement employed; a lid, *e*, is arranged, capable of being lowered on to the pan, *a*, and closing it up airtight by means of the flanged rim, *b b*, so that in the event of the evolved vapours taking fire they can be almost instantaneously extinguished. To avoid frothing over, the pan is originally filled not more than half full with oil.

Fig. 77 represents a pair of steam heated kettles, the jackets being strong enough to resist several atmospheres pressure: usually 4 to 5 atmospheres are employed, the oil being heated to 130° C. or a little upwards. When air is blown through the hot

* Hartley & Blenkinsop's process (Patent No. 11,629, 1890) combines the drying action of manganese soap added in this form with the bleaching action produced by blowing a current of air through the mass at a temperature a little short of 100° C.; by using only a small proportion of manganese linolate solution, the oxidising action can be almost wholly confined to the colouring matter, so as to bleach the oil without producing any notable degree of other oxidation (*Journ. Soc. Arts, loc. cit. supra*).

oil a dome-shaped cover is fitted on to keep in splashes, provided with an exit pipe for the vapours evolved.

An improved vessel for boiling oil and suitable for many other kindred purposes has been recently described by T. Frederking.*

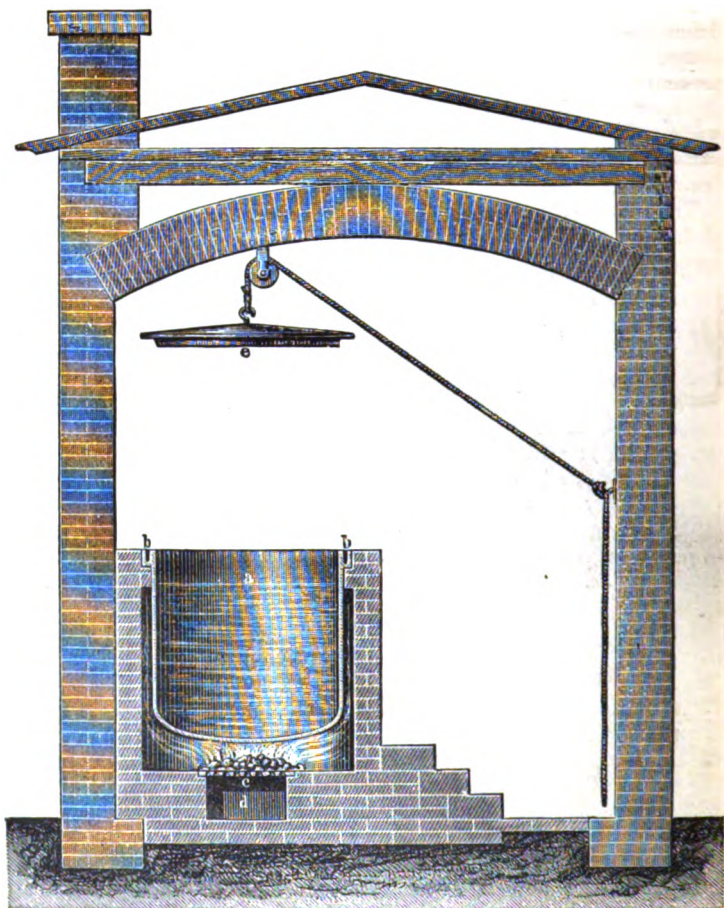

Fig. 76.

A coil of stout piping is arranged in a casting mould so that the molten metal forming the pan is cast round the coil ; much as is done in the case of the water-tuyeres of a blast furnace. Steam at any required pressure being passed through the coil, the pan

* *Chemical News*, Jan. 27, 1893 : German Patent No. 63,315.

is heated up proportionately without any danger, the pressure bearing solely on the piping and not on the metal pan itself, whilst the well-conducting metal walls allow the heat to pass readily. Temperatures up to 350° and 400° C. can be thus obtained.

According to C. W. Vincent* the use of air alone without driers does nothing towards making oil "drying." Linseed oil heated for three days consecutively at a high temperature in presence of the air but without driers required the same time to dry as the raw oil from which it was prepared, but the "body" was much increased. Heating alone for the same time with only surface exposure to air produced no such increase of body; the oil became more greasy, less penetrative, and less drying.

The exact nature of the changes taking place during the boiling of drying oils is not clearly understood; beyond the fact than an incipient alteration is produced (either by decomposition by

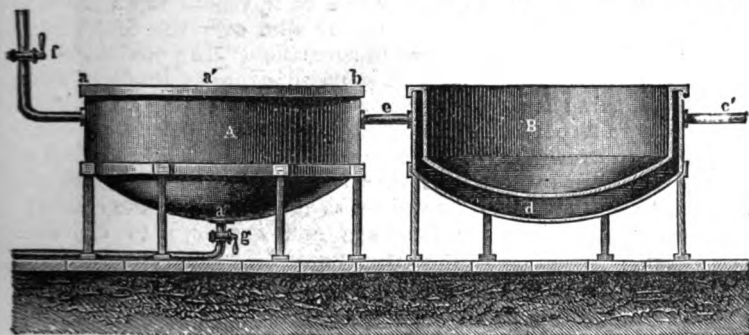

Fig. 77.

heat, or by oxidation, or both together, largely assisted by the carrier action of the driers), which tends in the direction of the further changes effected by the absorption of oxygen whilst drying, little is known with certainty. No considerable destruction of glycerides appears to occur until the action is pushed very far, ordinary "boiled" linseed oil furnishing nearly the same amount of glycerol on saponification as raw unboiled oil; on the other hand, a more or less distinguishable small diminution in iodine absorbing power is generally brought about indicating oxidation. For the further changes effected during actual "drying," see pp. 129, 134.

In the manufacture of printing ink, the action is pushed considerably further. In the older direct-firing process (still preferred by many) the oil is heated until the escaping vapours

* Muspratt's *Dictionary of Chemistry*, edited by C. W. Vincent, p. 475, vol. ii.

will fire freely; the mass thickens considerably as the action progresses; when a sample taken out and dropped on a cold porcelain surface can be drawn into strings half an inch long, a cover is put on to extinguish the flame; amber or rosin is then dissolved in the hot oil, and slices of soap (essential in order to enable the ink to adhere to damp paper); and finally the pigment (lamp black, ivory black, &c., mixed with prussian blue or other coloured pigments to tone the black as required). Obviously in this case the heat causes a partial decomposition of the oil, and the thickening is probably due largely to an action of polymerisation taking place in the nascent acids or anhydrides thus formed, somewhat analogous to that which occurs during the "vulcanising" of oils by the action of sulphur chloride, &c. (p. 154).

The varnishlike film of oxidised oil produced when boiled linseed oil is made to form a thin coating on a suitable large surface freely exposed to the air can be increased to an almost indefinite extent by painting a second film over the first when approaching dryness, and so on in succession. The product thus formed is largely employed in the manufacture of linoleum and floorcloth, thin sheets of canvas or cotton scrim being suspended vertically in a room freely supplied with air, and "flooded" with oil from an overhead reservoir or tank running on wheels like a travelling crane; the sheets thus moistened with a film of oil are kept suspended with free access of air, and when the coating is nearly dry, alternate floodings and exposure to air are repeated for some weeks until the "skin" formed is sufficiently thick, the chamber being supplied with warmed air if necessary, so as to keep its temperature up to at least 70° F. = 21° C., and freely ventilated, much acrid vapour (acrolein, &c.) being evolved during the oxidation by the destruction of the glyceridic portion of the oil. The oxidised oil thus formed is heavier than water (raw linseed oil has the specific gravity .935 or thereabouts), and forms a yellow translucent mass, insoluble in alcohol, ether, chloroform, and carbon disulphide; boiling naphtha (under pressure) softens it so that it can be worked into a paste. For the manufacture of linoleum the skins are ground between rollers, and heated with rosin and kaurie gum in a mixing pan, and the resulting paste or "cement" then intermixed with rasped cork and ultimately spread upon a canvas backing.

Notwithstanding the loss of weight due to the evolution of acrolein and other volatile products during this process, a gain in weight averaging about 11 per cent. is experienced, so that the fixation of oxygen is considerable. In order to shorten the time requisite for the oxidation of drying oils for linoleum manufacture, F. Walton* forces air at a pressure of 5 to 10 atmospheres through the oil warmed to about 100° F. = 37° C.,

* Patent Specification No. 12,000, July 31, 1890.

the air current being divided by means of perforated plates; an agitator is provided, by means of which the product when approaching solidification is more or less granulated, whilst fused gums, &c., can be incorporated.

Blown Oils.—Of late years the manufacture of oils oxidised by the direct action of air upon them, has acquired a considerable magnitude, the effect produced usually being a considerable increment in density and viscosity, rendering nondrying or semidrying oils (rape, cotton seed, fish oils, &c.) more suitable for use as lubricants, either directly or as ingredients in lubricating mixtures; and in the case of drying oils (more especially linseed oil), bringing about more rapidly and certainly those incipient oxidation changes requisite to produce more rapid spontaneous absorption of oxygen from the air by the oil, when spread out in thin layers—*i.e.*, the changes effected in so-called “boiled” oil, rendering it better applicable for the production of paint and varnish, &c., owing to its more rapidly “drying” up to a comparatively hard varnish-like coating when thus applied.

The plant employed for the process is of simple construction, consisting of a pan or tank fitted with a steam jacket (or an internal dry steam coil) for heating up the oil, and with a false bottom perforated with numerous small holes, cullender-fashion; air being pumped in under the false bottom rises up through the hot oil in numerous minute streams of bubbles. Instead of a false bottom, a horizontal serpentine with numerous pin holes is sometimes employed. When the action is intended to be carried to the limit, as in oxidising drying oils for linoleum making, an agitating arrangement is also added for the purpose of breaking up clots, and keeping the mass well stirred up (*supra*).

The nature of the chemical changes taking place during the action of air on hot lard oil, cotton seed oil, rape oil, &c., has not been thoroughly elucidated; a considerable amount of heat is developed during the process, so that, when once started, no further extraneous heating is requisite, but in some cases rather the converse, otherwise the temperature may rise so high as to injure the product by incipient decomposition. In all probability the olein present (or other homologous glyceride) becomes largely converted into the glyceride of an oxyoleic or oxystearic acid, either analogous to the ricinoleic acid of castor oil (*i.e.*, an unsaturated hydroxylated acid), or more probably constituted like anhydrodioxystearic acid (pp. 42, 46), where the oxygen is directly added on in the same way that iodine or bromine is added, so as to convert an unsaturated acid into a saturated derivative; for in proportion as the oxidation proceeds, the iodine absorption lessens. Other subsidiary actions, however, also take place; thus, the proportion of insoluble acids (Hehner number) lessens as the oxidation goes on, whilst increasing amounts of soluble acids are formed; the mean saponification

equivalent of the blown oil is usually less than that of the original oil (*i.e.*, the "total acid number" increases), although but little increment is brought about in the "free acid number." Blown oils develop much more heat on mixing with sulphuric acid than the original untreated oils.

The following figures were obtained by Thomson and Ballantyne* in the course of a series of experiments on the oxidation of rape and sperm oils by blowing hot air through them :—

RAPE OIL.

	Original Oil.	Partly blown after 5 hours.	More fully blown after 20 hours.	Commercial Blown Rape Oil.
Specific gravity at 15° 5,	0·9141	0·9275	0·9615	0·9672
Percentage of free acid (calculated as oleic acid),	5·10	5·01	7·09	4·93
Percentage of unsaponifiable matter,	0·65	...	0·76	2·80
Total acid number,	173·9	183·0	194·9	197·7
Iodine number,	100·5	88·4	63·2	63·6
Specific temperature reaction (p. 149),	135°	253°
Percentage of insoluble acids (Hegner number),	94·76	...	85·94	82·40
Molecular weight of insoluble acids,	327	317
Percentage of soluble non-volatile acids,	0·52	...	9·20	11·16
Percentage of soluble volatile acids,	0·82	1·90
Iodine number of soluble acids,	66·5	70·2

SPERM OIL.

	Before blowing.	After blowing for 26 hours.
Specific gravity at 15° 5,	0·8799	0·8989
Free acid (calculated as oleic),	1·97	3·27
Unsaponifiable matter,	36·32	34·65
Total acid number,	130·4	142·3
Iodine number,	82·1	67·1

Commercial blown oils usually present nearly the same density and viscosity as castor oil, but differ therefrom in not dissolving freely in alcohol, whilst they are readily soluble in petroleum spirit, and mix readily with the heavier petroleum hydrocarbons, thus enabling homogeneous lubricating mixtures to be produced.

* *Journ. Soc. Chem. Ind.*, 1892, p. 506.

Castor oil itself when similarly blown undergoes analogous changes, becoming still more viscid, and acquiring the property of being miscible with hydrocarbons (ordinary castor oil is almost insoluble in petroleum hydrocarbons, &c.); accordingly, blown castor oil is often spoken of as "soluble castor oil." The same term, however, is sometimes applied to the oil treated with sulphuric acid (Turkey red oil).

Oxygen Process.—A process has been brought out under the auspices of "Brin's Oxygen Co." whereby commercially pure oxygen (containing 90–93 per cent. of actual oxygen) is used instead of air for the purpose of "boiling" linseed oil for varnish oil and linoleum, and similarly blowing other oxidisable oils, either in presence of a small quantity of driers, or without them.* In carrying out this process it is found unnecessary to blow the gas *through* the oil; a steam jacketed pan is provided capable of being closed by a cover, and containing an agitator consisting of vertical rods or vanes moving round horizontally. When the oil to be treated has become heated nearly to 100° C., the agitator is set in motion, and oxygen led in to the space *above* the oil; the splashing oil drops present a large absorbent surface, so that the oxygen is absorbed, at first comparatively slowly but later on with great vigour, so that although a rapid stream of gas is delivered into the pan it is absorbed more rapidly than it is supplied, producing a partial vacuum. As the action goes on the oil heats greatly, so that ultimately it becomes necessary to *cool* the jacket by admitting water into it. It is claimed that the oxidising action is under better control by this treatment, and that a superior result can be effected in a much shorter time, so that the extra cost of the oxygen gas is amply recouped.

A somewhat similar process has been subsequently patented by E. Opderbeck † for making "consistent fish fat, train, and other oils," by heating them to 90°–100° C., and then intimately commingling them with compressed oxygen.

MISCELLANEOUS USES OF OILS, FATS, &c.

MANUFACTURE OF LUBRICANTS.

The substances employed to diminish the friction between surfaces in motion relatively to one another are of very various kinds according to the nature of the mechanism, &c., to be lubricated; thus for watches and chronometers on the one hand, and railway axles on the other, widely different substances are respectively

* English Patent Specs., 12,652, 1886; 18,628, 1889.

† English Patent Spec., 24,153, 1892.

best suitable; whilst the spindles of cotton spinning jennies, the piston boxes of steam engines, and the bearings of shafting generally, represent other different classes of moving objects for each of which special kinds of lubricants are requisite. Formerly animal and vegetable oils and fats were almost exclusively used for lubricating purposes, the finer qualities being employed for the more delicate machinery and the coarser varieties and dirtier greases for the greasing of cartwheels and similar rough purposes: the introduction of railway travelling and the extended use of machinery of all kinds led to the modification of some of these materials by partial saponification with lime or alkalies so as to produce an imperfect soap containing much unsaponified fat, and to the admixture with them of more or less viscous hydrocarbons, more especially the "rosin oils" prepared by the distillation of rosin, and certain higher boiling fractions obtained in the treatment of petroleum shale oils, coal and other tars, and similar substances. At the present day "mineral oils" of this latter kind are most extensively used, either alone or in combination with saponifiable oils, although for certain special purposes the latter are still preferable. Obviously only those kinds of mineral oil are available that do not readily give off inflammable vapours on account of risk of fire, and the drying up of the lubricant by evaporation; moreover, lighter oils of this kind have not sufficient "body," especially for heavy machinery.

Of the animal oils, sperm oil stands pre-eminent, neat's foot oil, tallow, and lard oil being also valuable ingredients largely used, and to a lesser extent whale oil and various fish oils; whilst olive oil, palm oil, and rape oil, and to a lesser extent cotton seed, sesamé, and groundnut oils, &c., are also extensively employed. In all such cases it is imperative that no free mineral acid should be present, as otherwise bearings, &c., are apt to be rapidly corroded: hence oils refined by acid processes (p. 259) are usually regarded as inadmissible as ingredients in first-class lubricating oils, unless the small quantities of admixed mineral acid have been thoroughly removed by a subsequent washing with an alkaline fluid. There appears also to be good reason for regarding the presence of any considerable percentage of free organic acids as objectionable for similar reasons, more especially in the case of bearings made of gun metal and other copper alloys, inasmuch as in presence of such acids the copper is apt to become oxidised, producing corrosion and pitting; hence oils refined by alkaline treatment are preferable. Cotton seed oil thus refined (for the purpose of removing resin, p. 260) owes much of its value to the circumstance that it is practically destitute of free acids, which to a great extent counterbalances the objection to its use that, as a considerable proportion of drying glycerides is present, it possesses a rather marked tendency to absorb oxygen and thicken or "gum" in use.

Animal and vegetable oils liable to contain free mineral acids, may be conveniently examined as to the presence of such constituents by the process described on p. 123; or the oil may be well shaken up with distilled water, and the aqueous liquor separated and examined, whilst the amount of free organic acids may be determined by the titration method described on p. 116. A practical test as to the relative tendency to gumming is to place equal quantities (drops) of the oils to be examined on an inclined plane, noting the distance run down by each sample in a given time, and the time required before the oil ceases to run, owing to the increased viscosity through oxidation; thus, the following figures are quoted from Appleton's *Dictionary of Mechanics*, representing the run of each oil in inches:—

	Sperm Oil.		Gallipoli (Olive) Oil.	Lard Oil.	Rape Oil.	Linseed Oil.
	Best.	Common.				
1st day, . .	32	19	10	10·25	14	17·5
2nd „ . .	50	45	14	10·5	18	18
3rd „ . .	53·5	55	18	10·75	19	18
4th „ . .	54	59	18·5	10·75	19	18·25
5th „ . .	54	62	19·5	11·75	19·25	18·5
6th „ . .	54	64	20·5	Still	19·25	Still.
7th „ . .	54	67	21	...	19·75	...
8th „ . .	54	67·5	21·25	...	Still.	...
9th „	68	21·5

Only comparatively small amounts of unmixed animal and vegetable fats and oils are used alone at the present day as lubricants; a large proportion of the lubricating agents employed consist of hydrocarbons only, and the remainder are much more frequently mixtures of hydrocarbons with saponifiable oils, than substances free from petroleum and rosin oils, and such like hydrocarbons.

One advantage gained in the case of such mixtures (apart from cheapness) is, that greasy rags, engine waste, &c., impregnated with oil, are much less likely to heat spontaneously through oxidation on storage (p. 132), when a large fraction of the oil is nonspontaneously oxidisable hydrocarbon, than would be the case were the oil wholly composed of glycerides and such like saponifiable bodies.

W. Brink finds* that the solution of a small quantity of caoutchouc in a lubricating oil consisting of mineral hydrocarbons increases its viscosity and tends to prevent gumming, without introducing any corresponding disadvantages. Various metallic

* English Patent Spec., 17,163, 1889.

soaps, more especially aluminium oleate, are often added to lubricating oils for the purpose of increasing their "viscosity;" it is open to much question, however, whether such an addition really adds to the true lubricating power of the composition, and whether it should not be looked upon simply as an adulteration or falsification giving a fictitious appearance of consistency to the oil.

Lubricating materials other than pure fats and oils, may be conveniently classified in the following divisions:—

1. Solid, semisolid, or more or less viscid liquid compositions of animal and vegetable oils and fats, with hydrocarbons from petroleum or destructive distillation (shale and paraffin oils), or resin oils containing little or no inorganic matters intermixed.

2. Solid or semisolid greases containing a considerable proportion of saponaceous matters (alkali or lime soaps of fatty or resinous acids), together with more or less additional mineral or organic "antifriction" substances (ground mica, steatite, plumbeous seaweed jelly, &c.)

3. Excessively coarse and generally dark coloured greases, consisting of byproducts of various industries, the refining of which is too costly to permit of the materials being purified sufficiently to enable them to be utilised in other ways—*e.g.*, "Yorkshire grease," and grease from engine waste (p. 236), containing too much hydrocarbons, &c., to be worth distilling for so-called "stearine" and "oleine" (p. 277); "dead oils" obtained in coal-tar distillation; certain kinds of "foots" obtained in refining; pitchy and tarry matters of various kinds not available for other purposes, and so on.

Lubricants of the first class include "engine oils," "engine tallow," and similar compositions; "cylinder oils" for lubricating the piston rods, &c., of steam engines; "machinery oils" for shafting, bearings, crank axles, and the like; "spindle oils" for quick moving light machinery, like the spindles of cotton spinning jennies; watchmakers', clock, and "turret" oils, specially adapted for delicate machinery like chronometers, and not liable to thicken by cold—and a large variety of subordinate kinds. Those of the second class are chiefly compositions used for the axle boxes of locomotive stock (railway trucks and carriages, &c.) Coarse greases of the third class are used for cartwheels and rough machinery, such as the pumping engines employed in mining, where, through the circumstances of the case, high class lubricants are unnecessary.

Lubricants of the First Class—Lubricating Oils.—The examination as to the practical lubricating value of materials and compositions of this class is rather a mechanical than a chemical problem. A laboratory test greatly relied on as an indication of their suitability for the particular purposes in view, is the determination of their relative efflux rates at given tem-

peratures. The so-called "viscosity" values thus obtained by means of one or other of the various forms of efflux viscosimeter described in Chapter v. (or better still, the figures obtained by means of appropriate large scale testing machines, &c., whereby the conditions obtaining during actual use can be nearly imitated) are generally of more practical value to the consumer than chemical analyses of the substances; especially when coupled with valuations of the flashing point (p. 125) and the degree of volatility—i.e., the rate of loss by volatilisation on heating to known temperatures. On the Continent considerable stress is often laid on the determination of the "congealing point" (*vide* p. 67). For an outline of the standard methods and appliances in use for the purpose, *vide Journ. Soc. Chem. Ind.*, 1890, p. 772.

Lant Carpenter summarises the general experience gained as to the character and behaviour of the various oils used for lubricating as follows:—

1. A mineral oil flashing below 300° F. (149° C.) is unsafe on account of causing fire.

2. A mineral oil evaporating more than 5 per cent. in ten hours at 140° F. (60° C.) is inadmissible, as the evaporation creates a viscous residue, or leaves the bearing dry.

3. The most fluid oil that will remain in its place, fulfilling all other conditions, is the best for all light bearings at high speeds.

4. The best oil is that which has the greatest adhesion to metallic surfaces, and the least cohesion in its own particles; in this respect fine mineral oils are 1st, sperm oil 2nd, neat's foot oil 3rd, and lard oil 4th.

5. Consequently, the finest mineral oils are best for light bearings and high velocities.

6. The best animal oil to give "body" to fine mineral oils is sperm oil.

7. Lard and neat's foot oil may replace sperm oil when greater tenacity is required.

8. The best mineral oil for cylinders is one having specific gravity 0.893 at 60° F. (15.5° C.), evaporating point 550° F. (288° C.), and flashing point 680° F. (360° C.)

9. The best mineral oil for heavy machinery has specific gravity 0.880 at 60° F. (15.5° C.), evaporating point 443° F. (229° C.), and flashing point 518° F. (269° C.)

10. The best mineral oil for light bearings and high velocities has specific gravity 0.871 at 60° F. (15.5° C.), evaporating point 424° F. (218° C.), and flashing point 505° F. (262° C.)

11. Mineral oils alone are not suited for the heaviest machinery on account of want of "body" and higher degree of inflammability.

12. Well purified animal oils are applicable to very heavy machinery.

13. Olive oil is foremost amongst vegetable oils, as it can be purified without the aid of mineral acids.

14. The other vegetable oils admissible, but far inferior, stated in their order of merit, are gingelly, groundnut, colza, and cotton seed oils.

15. No oil is admissible which has been purified by means of mineral acids.

A. H. Allen regards the following characters as those which should be taken into consideration in forming an opinion as to the suitability of a lubricating oil for a given class of work :—

1. The *viscosity* or “body” of the oil at the temperature at which it is to be used.

2. The temperature at which the oil *thickens* or actually *solidifies*.

3. The *flashing point* or temperature at which the oil gives off inflammable vapours in notable quantity.

4. The *volatility* or loss in weight which the oil suffers on exposure in a thin film to an elevated temperature.

5. The “gumming” character or tendency of the oil to become *oxidised*.

6. The relative proportions in which the *fatty* and *hydrocarbon oils* of a mixture are present.

7. The proportion and nature of the *free acid*, if any, in the oil.

8. The tendency of the oil to act on metals.

9. The presence of *mineral matters*, such as the metallic bases of soaps, &c.

As regards the degree of volatility of a lubricating oil, J. Carter Bell considers that it would be well for insurance companies to lay down a hard and fast rule that no lubricating oil should be used in any mill that has a flashing point lower than 350° F. (177° C.), and that loses more than 5 per cent. in twelve hours at 140° F. (60° C.)

Lubricants of the Second Class—Carriage and Waggon Greases.—For the axle boxes of railway rolling stock a peculiar kind of imperfect soap is found to answer well, usually made by melting tallow and palm oil together, and then thoroughly intermixing a solution of sodium carbonate in water, for which purpose Morfit's steam twirl (Chap. XIX.) answers well; or a boiled palm oil soap is dissolved in hot water and thoroughly intermixed with melted tallow, the emulsified mass being then cooled so as to solidify.

Richardson & Watts* give the following receipts as furnishing compositions of this kind that have been used with excellent results, that marked “summer” running for 1,200 miles :—

* *Chemistry applied to the Arts and Manufactures*, vol. i., part iii. p. 744.

	Winter.				Summer.			
	Cwts.	qrs.	lbs.	Lbs.	Cwts.	qrs.	lbs.	Lbs.
Tallow,	3	3	0	= 420	4	2	0	= 504
Palm oil,	2	2	0	= 280	2	2	0	= 280
Sperm oil,	0	1	7	= 35	0	0	27	= 27
Soda crystals,	1	0	14	= 126	1	0	8	= 120
Water,	12	3	12	= 1,440	12	0	26	= 1,370
	20	2	5	2,301	20	2	5	2,301

These quantities are reckoned to give 1 ton = 2,240 lbs. of grease, allowing about $2\frac{1}{2}$ per cent. for loss.

A. H. Allen gives the following composition of a similar German waggon grease:—

Tallow,	24.6
Palm oil,	9.8
Rape oil,	1.1
Caustic soda,	5.2
Water,	59.3

100.0

The following composition, containing a smaller proportion of saponaceous matter, has been patented by Hervieux and Bedard* as a superior form of axle grease:—

Codfish oil,	24 parts.
Beef tallow,	16 "
Rosin,	1 "
Soft soap,	2 "

A somewhat analogous imperfect lime resin soap is used for railway trucks unprovided with axle boxes, carts, and waggons, and similar vehicles; this is made by elutriating slaked lime (by stirring up with water and running the "milk of lime" through a succession of settling tanks), and thoroughly intermixing the limemud with rosin oil in the cold; the resulting mass is often intermixed with coarse greases and other substances of the third class, and sometimes with mineral substances possessed of antifrictional qualities; thus the following composition has been patented by A. Purvis† as an improved lubricant capable of resisting unusually high temperatures:—

Japanese tallow,	2 cwt.
Russian tallow,	3 "
Olive soft soap,	2 "
Lard oil,	108 lbs.
Castor oil,	108 "
Carbonate of lime,	10 "
Carbonate of soda,	10 "

* English Patent Spec., 4190, 1889.

† English Patent Spec., 13,936, 1890.

The mass is heated and well intermixed, with the addition of $\frac{1}{2}$ cwt. of finely pulverised mica, or of china clay, or of the two together. After standing twenty-four hours it is again heated, and 20 lbs. of zinc oxide added; after thoroughly commingling the mass is then subjected to hydraulic pressure so as to squeeze out any water present.

Numerous analogous mixtures, consisting essentially of tallow or oil, soap of some kind, and solid powdery matter (such as graphite, steatite, or sulphur) are in use as antifriction compositions.

Greases of the Third Class.—These are the most dangerous lubricating materials in use from the point of view of liability to inflammation; refuse coaltar dead oils, anthracene oils, creosote oils, &c., have frequently a relatively very low flashing point, and when once set on fire are not easily extinguished. Such compounds should not be used at all in a mill or similar building where great damage by fire might be occasioned.

Analysis of Lubricating Oils and Greases.—Oils, &c., consisting wholly of organic matters will obviously leave no ash on careful incineration, whereas if any soapy material or other inorganic "antifriction" constituent be present, more or less residue will be left when a known weight of substance is cautiously heated (*e.g.*, in a platinum dish) and the residual carbon burnt off. An examination of this residue may be made as regards the quantity of alkali contained, the amount of lime, alumina, steatite, &c., present, and so on.

Organic suspended matters, such as Irish moss or seaweed jelly, lime or other soaps insoluble in ether or petroleum spirit, &c., may be conveniently sought for by thinning the material with the solvent, and passing through a weighed filter, finally washing out all soluble matters; the residue may be weighed, a portion incinerated to obtain the proportion of inorganic matters present, and the remainder further examined as may seem requisite. When metallic soaps (alumina, iron, &c.) are present, the metallic basis can be conveniently removed by thinning the grease with ether, &c., and agitating with water strongly acidulated with hydrochloric acid.

When saponaceous matters are present (*e.g.*, when the "foots" from oil refining by alkaline processes (p. 260) are used as ingredients, or when lime and rosin spirit, or soda and palm oil, &c., are used, as with certain kinds of waggon grease), the methods employed in soap analysis are available with suitable modifications; thus the total alkali present may be conveniently found by shaking with ether and a slight excess of standard acid (hydrochloric or nitric), separating the watery part and back-titrating the excess of acid not neutralised. By adding phenolphthalein to an alcoholic solution of the oil or grease, and cautiously dropping in standard acid, and shaking after each

addition, the amount of alkali or alkaline earth present otherwise than as soap may be at least approximately determined; and by further diluting with water, adding ether, petroleum spirit, carbon disulphide, or other convenient solvent, and excess of standard acid, the total alkali, &c., may be determined as above; whilst after separating the solution of oil in ether, &c., the fatty and resinous acids set free may be titrated therein in the usual way (p. 116).

Glycerides (animal and vegetable oils and fats) and liquid waxes (sperm oil, &c.) are determined as with ordinary oils (p. 162); after neutralisation of free fatty acids (or alkalies) excess of standard alkali is added with alcohol, and the whole boiled some time with an inverted condenser and the alkali not neutralised determined; the product diluted with water and shaken with petroleum spirit gives a watery solution of the soap formed by saponification of the glyceride, from which the contained fatty acid may be separated and subjected to examination; whilst the petroleum spirit contains in solution the hydrocarbons present in the original grease, together with non-fatty acid oxidised matters, such as cholesterol from woolgrease, &c., the higher alcohols formed by saponification of sperm oil, and the like. When requisite these may be further examined by the acetylation process (p. 186).

As a general rule, the chemical analysis of a given lubricant affords very little information as to its suitability for any particular purpose; but certain laboratory determinations are often of considerable value, more especially the determinations of rate of loss of weight on heating to given temperatures for specified times; of the efflux "viscosity" at specified temperatures; and to a lesser extent of the specific gravity. The "flashing point" and the somewhat higher temperature of firing ("ignition point") are also important, especially with mineral oils. The principal chemical tests of practical value are those for free mineral and organic acids, more especially the former. The chief utility of analysis in the case of lubricating oils is to decide whether they are of the composition stipulated for in a contract—*e.g.*, as to containing a given percentage of sperm oil intermixed with hydrocarbons, and so on; or to see whether otherwise genuine—*e.g.*, in the case of rape or castor oil, as to whether adulterated with other substances, such as cheaper oils or hydrocarbons; or in the case of blown oils whether artificially thickened by addition of soft soap, aluminium oleate, rosin, and so on.

Occasionally it is required to find out whether rosin oils have been admixed with mineral oil lubricants; for this purpose the glacial acetic test described on p. 57 may be conveniently used, rosin oils being readily soluble in that solvent whilst mineral oils are practically insoluble therein.

Rate of Absorption of Oxygen.—According to O. Bach

the facility with which a lubricating oil absorbs free oxygen is a useful measure of its "gumming" tendency. By sealing up in a glass tube containing 100–125 c.c. quantities of oil of from 3 to 5 c.c., after displacing all air by oxygen, and heating for ten hours to 110° C., a more or less considerable absorption of gas takes place, readily determined by opening the sealed-up end of the tube under water, and noting the amount of inrush. Thus various kinds of oils gave the following numbers:—

1 gramme of	Valve oil (mineral)	absorbed	0.1 c.c. of oxygen.
"	Valveoline	"	0.45 "
"	Lubricating oil	"	0.7 "
"	Oleonaphtha	"	8.6 "
"	socalled "Cod oil:" sp. gr. 0.963	"	76.3 "
"	Olive oil	"	144.0 "
"	Rape seed oil	"	166.0 "
"	Cotton seed oil	"	111.0 "
"	Rosin oil	"	181.0 "

Little or no acidity is shown by the water sucked in with mineral oils, but with others with which the absorption of oxygen is large, a strong acid reaction is manifest, especially in the case of rosin oil.

TURKEY RED OILS.

The chemical differences between the two kinds of oils treated with sulphuric acid known under the name of "Turkey red oils" have been already described (p. 143, *et seq.*)* In the practical

* Since that description was written a paper by P. Juillard has appeared on the action of sulphuric acid on olive oil, and the nature of olive Turkey red oil (*Journ. Soc. Chem. Ind.*, 1893, p. 528, from *Bulletin Soc. Ind.*, Mulhouse, 1892, p. 413). The first action at 0° to 5° is described as the direct combination of one and of two molecules of sulphuric acid with olein forming mixed glycerides, containing simultaneously the radicals of oleic and oystearosulphuric acids, and respectively indicated by the formulæ—

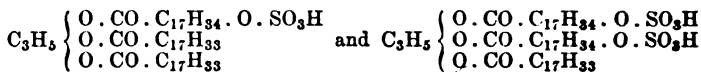

By the further action of sulphuric acid, these give rise to other more complex mixed glycerides containing simultaneously the radicals of sulphuric and oleic or oystearosulphuric acids, and also that of a "polymerised" oleo-oxy-stearic acid, viz:—

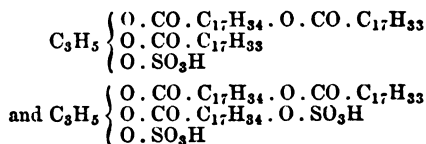

Commercial olive Turkey red oil chiefly consists of the sodium salts of these acids and of their derivatives and products of decomposition (oleic, oxy-

manufacture of the castor oil products it is generally considered indispensable to prevent the temperature from rising materially above 35° or at most 40° C., otherwise secondary reactions take place, leading to evolution of sulphurous acid, and production of inferior products. The oil is run into a wooden tank, preferably lined with sheet lead, and provided with cocks at different heights to facilitate the running off of wash liquors, &c. ; the sulphuric acid is then gradually run in with continual agitation, either by hand-worked paddles or by a mechanical agitator. Considerable differences in the practice of various makers occur in this stage of the process, the precise details of working being usually regarded as trade secrets ; in some cases the acid is run in at one operation, more especially when the proportion employed is smaller ; in others part added at one time, and the rest at intervals ; sometimes half being added one day, and the other half the next day. The proportion of acid used also varies considerably,* from 15 to 40 per cent. of the weight of oil used. After standing 14–24 hours, a solution of common salt is run in and the whole well agitated with the object of removing excess of free sulphuric acid not converted into compound acids, glycerol, glycerosulphuric acid, and such like substances soluble in water, without removing the soluble compound sulphuric acids formed, these being much less soluble in brine than in plain water. If during this washing the liquor become much heated, considerable loss is brought about because dilute hydrochloric acid is formed which rapidly hydrolyses the compound acids present ; plain water is, therefore, sometimes used for a first washing, and brine or, better still, sulphate of soda solution for subsequent ones. A certain amount of soda or ammonia is then run in to the washed oil and well admixed, so as to neutralise part (but usually not all) of the free acidity ; finally enough water is added to bring down the percentage of oleaginous matter present to the requisite extent, 50 or even less in some cases. The ultimate product is consequently a sort of emulsion of undecomposed fatty matter and free acids disseminated through a watery solution of the soaps formed by the action of the alkali added on the free fatty acids and compound sulphuric acids formed ; if properly prepared so as to contain the latter in sufficient quantity, castor Turkey red oil can be diluted with water without allowing oily drops to separate until after standing some considerable time ; and may be dissolved in ammonia and diluted with water without becoming seriously turbid through separation of oil, &c. If much precipitation is visible solid fatty glycerides are present, due to adulter-

stearic, oleostearic, oleo-oxystearic acids, &c.) formed during the process of washing out the uncombined sulphuric acid.

For a summary of the bibliography of the chemistry of Turkey red oils *vide Journ. Soc. Chem. Ind., loc. cit.*

* J. A. Wilson, *Journ. Soc. Chem. Ind.*, 1891, p. 26 ; 1892, p. 495.

ation of the original castor oil with rape or cotton seed oil, &c.

According to P. Lochtin* the risk of spoiling the product prepared from castor oil and sulphuric acid by overheating is much less than is commonly supposed, firstly because no decomposition involving the formation of sulphuric acid is produced at temperatures not exceeding 70°, excepting that due to albuminoid impurities; and secondly, because in his view only the free fatty acid is of use in the dyeing process, some of the best preparations only containing 2 to 5 per cent. of sulphuric anhydride (SO₃) per 100 of fatty acids (ricinoleosulphuric acid theoretically corresponds with a ratio of 80 parts SO₃ to 298 of ricinoleic acid, or 27 per 100). Moreover, the product of saponification by alkali (necessarily containing no compound sulphuric acid) gives very fine shades in practical dyeing, although the tendency to frothing causes the colour to be a little uneven. The alkali added, he considers, should be ammonia and not soda or potash, because in printing steam colours the alkali is volatilised and the free fatty acid left on the cloth. In winter 20 to 30 parts, and in summer 15 to 20, of concentrated sulphuric acid are used (in Russia) per 100 of castor oil; about one half of the acid is stirred gradually into the oil during nine hours of a working day; the mixture is allowed to stand all night, and the next day the rest of the acid is stirred in and the mixture allowed to stand until a sample taken out exhibits a clear solution, when a few drops are shaken with distilled water in a test tube: if allowed to stand too long a cloudy fluid is obtained, just as when the action has not been sufficiently prolonged. At the proper time, an equal bulk of cold water is added to the fluid, when the oil separates and floats on the diluted acid solution; if a larger proportion of free fatty acid (hydrolysed sulphuric compounds) is desired, hot water is used instead of cold.

Formerly this hydrolytic decomposition was usually regarded as the chief thing to be feared and avoided in manufacturing Turkey red oils; but recently such oils have been placed on the market under the name of "oxyoleates" by Messrs. Schmitz & Tøenges, of Heerd (Düsseldorf), in the preparation of which the salted out fatty acid is purposely heated to 105° to 120° C., whereby practically all sulphur is eliminated in the form of sulphurous and sulphuric acids.† According to P. Werner,‡ these products are, for certain applications, superior to the usual Turkey red oils containing sulphurised acids.

Analysis of Turkey Red Oils.—In order to hydrolyse the compound sulphuric acids present, a weighed quantity is agitated with about twice its volume of saturated brine, and about one-

* *Journ. Soc. Chem. Ind.*, 1890, p. 498.

† *English Patent*, 14,430, 1891.

‡ *Journ. Soc. Chem. Ind.*, 1893, p. 40.

tenth its volume of strong hydrochloric acid, whereby hydrolysis is speedily brought about; the product is then shaken up with ether, the ethereal solution evaporated to dryness, and the residue purified by solution in alcohol and filtration to remove saline matters, and evaporation till all alcohol is driven off (J. A. Wilson). The residue is examined so as to determine the amount of unaltered glycerides present along with the free acid by the ordinary methods described on pp. 116, 157. The proportion of ricinoleosulphuric acid originally present is ascertained by determining the total amount of barium sulphate obtained from the acid brine, and subtracting therefrom the amount present as ordinary sulphate obtained by agitating the oil with brine and ether in the same way, but without the addition of hydrochloric acid. Obviously the weight of compound sulphuric acid deduced from the corrected weight of barium sulphate thus obtained will be very different according as it is reckoned as ricinoleosulphuric acid or diricinoleosulphuric acid (p. 146), 233 parts of barium sulphate corresponding with 378 parts of the first and with 658 of the second, and consequently with 518 parts of a mixture of the two in equivalent proportions.*

Another mode of determining the relative proportions of sulphurised and non-sulphurised acids present is to titrate with standard alkali twice, using litmus as indicator in one case, and phenolphthalein in the other; the sulphurised acids are given by the first titration, and the others by the difference between the two. Scheurer Kestner recommends ammonia as the alkali, notwithstanding the uncertainty of the indications of phenolphthalein therewith.

Juillard† condemns this method of examination as giving inaccurate results, in the light of his own more recent researches (*supra*; *vide* also p. 147), more especially when diricinolein sulphuric anhydride is present, as is usually the case. He considers that the essential determinations are those of the fatty acids in the usual way, and of sulphuric acid and glycerol after hydrolysis of the oil by boiling with dilute hydrochloric acid. In view of the different shades yielded in dyeing and printing by the various components of the oil, a determination is desirable of the molecular weights of the fatty acids present in the soluble and insoluble states. This may be accomplished by Raoult's method, care being taken to use enough water to bring into solution the whole of the

* 402 was found by Scheurer Kestner as the equivalent weight of mixed compound sulphuric acids formed in one case, 480 being the corresponding value of the non-sulphurised acids simultaneously produced (ricinoleic acid = 298; diricinoleic acid = 578).

† *Journ. Soc. Chem. Ind.*, 1892, p. 357; from *Bulletin Soc. Chim.*, Paris, 1891, 6, p. 638.

soluble acids. As usually prepared, Turkey red oils contain some 45 or 50 per cent. of oil capable of being separated by means of hydrochloric acid and brine, the balance being water and small quantities of saline matter, &c. Of the separated oil generally about one-fourth consists of unaltered glycerides. The alkali added is usually insufficient to neutralise all the free acid, as a rule only about one-third being neutralised. On addition of water and ammonia to the product a clear emulsion or solution is formed if solid glycerides are absent; but a more or less turbid fluid on account of precipitation if these are present through use of adulterated oil, &c.

In order to examine Turkey red oil (from castor oil) for adulteration with cotton seed oil and other glycerides, J. A. Wilson recommends (*loc. cit. supra*) that a weighed quantity of oil (100 grammes) should be saponified by boiling with methylated spirit (250 c.c.) and pure caustic potash (20 grammes) for an hour, with inverted condenser attached; after evaporating off the alcohol, the residue is dissolved in half a litre of water, and the soap decomposed with a slight excess of sulphuric acid, boiling the whole for an hour. To avoid bumping, a piece of pumice stone coiled round with platinum wire should be placed in the flask. After standing, the fatty acids are collected by siphoning off the acid liquid through a filter, and washed several times with hot water, and then dried at 100°, and examined further. The specific gravity at 98°, as taken with a Westphal balance, varies considerably according as the fatty acids are derived from castor, olive, or cotton seed oil; thus—

Castor oil acids,	0·892 at 98° C.
Olive oil acids,	0·851 ,,
Cotton seed oil acids,	0·872 ,,

The fatty acids derived from pure castor Turkey red oil, not sophisticated with any other oil, do not deposit more than traces of solid matter at 15°·5, whilst much more is obtained with olive oil, and still larger amounts with cotton seed oil. The melting points of the latter two acids, when tested by the capillary tube pressure method after solidification, are—

Cotton seed oil acids,	44° C.
Olive oil acids,	40° C.

The neutralisation numbers of the fatty acids do not differ much—

Castor oil acids,	180 to 184
Olive oil acids,	173 to 176
Cotton seed oil acids,	171 to 175

The iodine number of the castor oil acids is very variable, being dependent on the age of the castor oil, and the method of preparing the Turkey red oil, especially the amount of sulphuric

acid used; so that no indications of any value as regards adulteration can be derived by its means.

The acetyl test, on the other hand, gives indications that are of service in this direction: the fatty acids are boiled for an hour and a half with four-fifths their weight of acetic anhydride with a reflux condenser, and the acetylated product washed with hot water till the washings are neutral to delicate litmus paper. A weighed quantity of the acetyl product is then exactly neutralised with alcoholic potash in the cold (whereby the "acetyl acid number" is obtained, p. 187); excess of potash is then added (about $1\frac{1}{2}$ times the first amount), and the whole boiled half an hour to saponify acetyl derivatives, the unneutralised potash being finally titrated. The amount of potash neutralised during this second part of the titration (*acetyl number*) varies considerably, according as pure castor oil has been employed, or castor oil admixed with olive or cotton seed oils; so that whether the observed "acetyl number" is wholly due to the saponification of acetyl derivatives, or (as seems more probable, p. 189) is partly due to the hydration of anhydrides formed by the action of acetic anhydride on fatty acids, in any case it affords a means of detecting adulterations; thus Wilson gives the following averages:—

	Acetyl Acid Number.	Acetyl Number.	Sum (so-called "Acetyl Saponification Number").
Castor oil maximum, .	144·0	143·4	287·4
" minimum, .	149·2	138·7	287·9
Olive oil,	158·7	106·3	265·0
Cotton seed oil, . .	179·0	53·0	232·0

These acetyl numbers are considerably higher than those yielded by the fatty acids obtained on saponifying olive and cotton seed oils not treated with sulphuric acid, quoted on p. 188, suggesting that either a considerable amount of oxystearic acid, or some analogous substance, is formed by the action of sulphuric acid on olein and saponification of the product; or else that the formation of anhydrides under the influence of acetic anhydride takes place more readily with the fatty acids obtained after treatment with sulphuric acid, than with those formed by the saponification of the original oils.*

Hydrocarbons (petroleum, rosin oils, &c.) are easily detected

* In all probability, the modification of the acetyl test proposed by Lewkowitsch (determination of "distillation acetyl number" instead of "titration acid number," pp. 190, 198) would give better results than those obtained by Benedikt and Ulzer's method, errors due to formation of anhydrides being thus eliminated.

in Turkey red oil by the process ordinarily used for the purpose described on pp. 119, 124.

CURRIERS' GREASE, SOD OILS, AND DÉGRAS.

During certain operations for tanning and currying skins, various forms of oil and grease are worked into the skin mechanically, and the excess subsequently removed, partly by pressure, partly by the emulsifying and saponifying action of alkaline solutions. When these fluids are decomposed by an inorganic acid an oily mass results, partly consisting of free fatty acids and partly of undecomposed glycerides. When tallow has formed part of the original grease or "dubbin" employed, the resulting recovered grease is of thicker consistency than that obtained when only liquid oils have been employed, such as olive oil, whale or cod oil, or menhaden oil. The greases thus obtained, or regained by pressure only, are sometimes known as "sod oils" or "dégras"; when cod oil and similar substances are absorbed in skins and exposed to the air, a certain amount of oxidation is brought about rendering the regained oil even better for use than the original unoxidised material; accordingly it is sometimes the practice (more especially in France) to prepare sod oil (Moëllon) for currying by absorption in skins used solely for the purpose, and subsequently wrung out again after sufficient exposure to air. Part of the good effect produced by sod oil and grease that has been already used previously is supposed by some to be due to the presence of tanning matters therein dissolved out from the leather and contained in a condition peculiarly adapted to the finishing of the tanning process in another skin; others believe that the beneficial effect is at least partly due to the solution in the grease of nitrogenous matters not affected by tanning and their subsequent removal by squeezing out the greasy solution, especially if the operation is done hot. The recovered dégras at any rate contains more or less nitrogenous matter, which is left undissolved as a resinoid mass when the material is treated with light petroleum spirit; further, a considerable amount of oxyoleic acid (or some similar oxy acid, such as dioxypalmitic acid) is usually present, and in the case of dégras made from train oils, more or less cetylic alcohol and similar bodies produced by the hydrolysis or saponification of their compound ethers, together with cholesterol; the presence of these substances enables fatty matters to become emulsified with water and thus to penetrate the tissues more readily, just as in the case of lanolin applied to a living skin (*infra*).*

Artificial dégras and curriers' greases and dubbin are prepared

* For analyses of various kinds of dégras, and a discussion of their general nature, *vide Journ. Soc. Chem. Ind.*, 1891, p. 557; 1892, p. 639.

by intermixing tallow and cod oil or similar materials, red oil (crude oleic acid from the candle factory, Chap. xvi.) and wool-grease sometimes entering into the composition, together with neutral soap, or imperfectly made soap prepared by heating together oil with an amount of alkali insufficient to saponify it completely. These products, however, are generally regarded as greatly inferior to that prepared by the oxidation of cod or other fish oils in contact with skins, so that for the finer kinds of French leather only the latter are employed.

Sod oils obtained by simple pressure from skins treated with olive, cod, or menhaden oil are valuable when properly refined for the lubrication of delicate machinery (clocks and watches, &c.), not being liable to clog and thicken.

MANUFACTURE OF LANOLIN.

Wool, as cut from the sheep's back, is largely impregnated with a greasy material, *suint*, the inspissated perspiration of the animal; this partly consists of various natural potash salts and soaps soluble in water, partly of cholesterol and isocholesterol and their stearic and other compound ethers, and to a small extent of cerylic cerotate, and other waxy organic matters. When solvent processes are employed for dissolving out the grease (*e.g.*, by means of ether or carbon disulphide) the substance obtained by distilling off the solvent is a tarry brown mass of unpleasant odour, of specific gravity at 15° about 0.973, melting at near 40°, sparingly soluble in alcohol, and only very difficultly saponifiable, as the cholesterol ethers are comparatively very stable; the "woolgrease" thus obtained is usually distilled by means of superheated steam, whereby a mixture is produced mainly consisting of free fatty acids and cholesterol, from which "wool stearine" is obtained by expression. Methods for cleansing wool by means of grease solvents have not come largely into use in Britain, it being usually considered that the heating requisite to remove the residual solvent from the wool does more injury than the action of soap in the ordinary wet process of wool scouring. Opinions on this point, however, are by no means unanimous.

On the Continent wool cleansing by means of solvents has made much more progress, and a variety of different forms of apparatus have been patented in which the use of ether, fusel oil, carbon disulphide, light petroleum spirit, benzene, &c., has been claimed.*

By treatment with water, fleeces yield a solution of potash

* For a description of Singer & Judell's arrangements in which carbon disulphide is the solvent, *vide* a paper by Watson Smith, *Journ. Soc. Chem. Ind.*, 1889, p. 24.

soaps in which the cholesterol and other compound ethers, &c., are emulsified: the extraction from the watery product thus formed of a purified emulsion for medicinal purposes was described by Dioscorides in the first century A.D., under the name of *Ὀσσεῖν*; a more refined preparation of the kind has of late years been somewhat largely employed under the name of *lanolin*. To prepare this material, Braun & Liebreich* subject the suds in which fleeces have been washed (or a mixture of woolfat and soapwater forming an analogous emulsion) to centrifugal action, whereby a separation is effected somewhat analogous to that produced in a cream separator; watery soap solution flows away, whilst a soft grease along with solid dirty particles is retained. The former is subjected to treatment with acids, &c., for the recovery of the fatty acids contained in the soap (Chap. XII.); the latter is purified by kneading with water, melting, and filtration, or solution in appropriate solvents, followed by further kneading with water until all soluble impurities are washed away. The purified greasy matter thus obtained possesses a remarkable power of forming a soft lard-like mass by the intimate commingling of water and grease so as to form a stiff semisolid emulsion. On account of the peculiar utility of this product as a vehicle for enabling drugs, &c., to be passed into the body by rubbing on the skin lanolin impregnated with the desired active material, and its use as an emollient unguent, either alone or in combination with other materials, it has of late years come somewhat prominently before the public: as also have various other substances differing therefrom in no essential particulars except the trade name, and in possessing varying degrees of purity.

Several modifications of Braun & Liebreich's centrifugal separation process have been subsequently introduced. In one of these, calcium chloride, or other similar salt, is added to the water so as to form insoluble lime salts or other metallic soaps; the separation of the grease is thus facilitated, whilst by means of hot acetone the cholesterol ethers, waxes, &c., present are subsequently dissolved out from the soaps; after distillation of the solvent the residual purified woolgrease is treated with oxidising agents to remove animal odour and lighten the colour, and is then kneaded with water till the requisite consistency is attained. Other processes of a fractional solvent character are also employed to separate from the crude "anhydrous lanolin"† some of the waxy ingredients, and thus obtain a product consisting principally of cholesterol, isocholesterol, and their ethers, and in consequence better adapted to form a semisolid emulsion with water, suitable as an unguent, &c.

Some of the products sent into the market and sold as

* English Patent Spec., 4,992, 1882.

† Vide Levinstein, *Journ. Soc. Chem. Ind.*, 1886, p. 579.

“purified woolgrease,” or under various fancy names, are of much less desirable character than others. Levinstein gives the following tests as those by which the purity of commercial lanolin may be ascertained:—

1. If 2 to 3 grammes of lanolin be heated with 10 c.c. of a 30 per cent. caustic soda solution, no ammonia must be disengaged.

2. 10 parts lanolin heated with 50 of distilled water must yield a clear oil. Impure lanolin becomes frothy and turbid.

3. If oily, the lanolin thus separated must be free from glycerol.

4. If rubbed with water with an iron spatula on a ground glass plate, the oil must be capable of taking up at least its own weight of water, forming a sticky and paste-like mass; if impure, the mass will have a soap-like smoothness, and will not adhere to the spatula.

Langbeck * describes the following process for preparing a purified lanolin:—The wool is washed twice in water at a temperature not exceeding 110° F., and dried by pressure or centrifugal action, whereby soluble potash salts are mostly removed; the residual wool is then scoured with a mixture of potash ley and olive oil, whereby all the “woolfat” is removed and the wool thoroughly cleansed. The watery emulsion is evaporated and treated with alcohol of 40 to 60 per cent., which dissolves out potash soaps, leaving behind crude “woolfat,” purified by solution in benzene or carbon disulphide, filtration, and distillation of the solvent. The product, after further purification and decolorisation with animal charcoal (preferably “prussiate waste”), and subsequently with peroxide of hydrogen, produces an excellent white basis for pomades, ointments, &c., containing 20 to 30 per cent. of mechanically intermixed water. The unpurified woolfat forms a valuable lubricant and leather grease.

A. Seibel has recently introduced a sulphurised lanolin † for medicinal and other purposes prepared by heating lanolin to 120° C., with about 20 per cent. of flowers of sulphur, whereby most of the sulphur is dissolved; after allowing to subside, the supernatant sulphur-containing liquid is poured off and heated to 230°, whereby much sulphuretted hydrogen is formed, together with the sulphurised lanolin; like ordinary lanolin, this mixes freely with water without separation, forming a soft semisolid emulsion.

* *Journ. Soc. Chem. Ind.*, 1890, p. 356.

† German Patent, No. 56,491.

CHAPTER XV.

ADULTERATION OF OILS AND FATS, &c.

THE adulterations mostly practised in the case of oils and fats, &c., may be broadly divided into two classes—viz., (1) those where some weight-giving ingredient is added of *wholly foreign nature*, as where an undue proportion of water is mechanically admixed with soft fats, such as butter and lard, or where starchy matters are added to the latter substance; and (2) those where the adulterant is a lower priced substance of *tolerably similar nature*, as where cotton seed oil is admixed with olive oil, hemp seed oil with linseed oil, or oleomargarine with cow's butter. In some cases mineral hydrocarbons (petroleum distillates) or destructive distillation oils (paraffin oils, rosin oil, &c.) are admixed with animal and vegetable oils; or substances largely consisting of unsaponifiable matters derived from woolgrease, &c., with tallow and similar saponifiable solid fats; here the nature of the adulteration is rather of the first class than of the second, inasmuch as by appropriate processes the adulterating impurity may (to a greater or lesser extent) be analytically separated from the material examined, and directly determined quantitatively; whereas when two closely similar natural oils, &c., are admixed, in most cases it is difficult, if not impossible, to effect any quantitative separation of constituents whereby the extent of the admixture can be directly determined, although in many cases the fact of the admixture, and some rough idea of its extent, can be arrived at by indirect means—*e.g.*, by the alteration in the melting point of the mixed fatty acids obtainable on saponification, or the increase (or decrease) in the iodine number or the saponification equivalent; or by the production of some particular colour change with a given chemical reagent, not shown by the natural unadulterated oil, &c.

In most cases of the kind, moderate certainty can only be ensured by making comparison tests side by side with the substances examined, and with known mixtures of pure oils, &c.; and here a great difficulty is at once encountered in obtaining standard samples of pure materials. In many instances this can only be done satisfactorily by preparation of the standards in the laboratory itself—*e.g.*, by expressing hand-picked samples of seeds, &c., so as to ensure that the seeds themselves shall not be mixtures of various kinds, and the oils extracted shall be free from all other sophistications. Even with all possible care in preparing pure substances for comparison, there still remains a certain amount of possibility of error, owing to the natural

fluctuations brought about by differences in the soil and climate, the degree of cultivation, and similar causes. Accordingly, the analytical detection of adulteration in oils and fats, &c., not only depends for the most part on very different principles from those involved in mineral analysis, *e.g.*, for metals, but also is a matter permitting of much less quantitative certainty.

The methods adopted in testing commercial samples of oils, fats, &c., necessarily vary with each substance examined, but in general consist of a suitable selection from the various methods above described, based on the physical and chemical properties of the oils, &c. (§§ 2 and 3); more especially—

The physical texture, colour, taste, and odour of the substance examined.

The effect on polarised light, and the refractive index.

The specific gravity of the substance, or of the fatty acids thence obtainable.

The fusing and solidifying points of these fatty acids.

The solubility in various solvents.

The efflux velocity at various temperatures.

The value of the "free acid number."

The percentage of unsaponifiable matters present (including water, suspended substances, and inorganic matters).

The nature of the elaidin formed, and its degree of consistency.

In the case of drying oils, the result of tests of rate of inspissation through oxygen absorption.

The effect of qualitative reagents in producing colour reactions (nitric acid, sulphuric acid, zinc chloride, &c.)

The degree of heat evolution on mixture with sulphuric acid.

The nature and consistency of the product formed with sulphur chloride.

The quantitative result of Kœttstorfer's test (saponification equivalent).

" " Hehner's test (insoluble acid number).

" " Reichert's test (volatile acid number).

" " Hübl's test (iodine number).

" " Benedikt and Ulzer's test (acetyl number).

The results of various special tests applicable in certain particular cases.

The following particulars respecting the normal properties of a few typical oils and fats, &c., and the effect thereon of various adulterations, will serve as illustrations of the methods usually

adopted in practice; for more full details, and for particulars respecting other substances, analytical treatises specially dealing with the subject must be consulted.* The methods of analysis applicable in the case of grease recovered from suds have been already discussed in Chap. XII., and those employed in the case of certain manufactured oils, &c. (Turkey red oils, butter substitutes, lubricants, &c.), in Chap. XIV.; soap analysis generally is dealt with in Chap. XXI.

As regards the general principles of detection of adulteration, it is to be borne in mind that the object of sophistication is essentially to sell a cheaper article at the price of a more costly one, by admixing the former with the latter; hence the relative price of different kinds of oils and fats, &c., at any given time, largely affects the question as to whether certain kinds of adulteration are likely to be practised or not. Although considerable variations in prices necessarily occur in the market from time to time, still it is possible to draw up a rough classification of oils, &c., according to their relative values when genuine. The following list is given by A. H. Allen (on the authority of Mr. T. Duggan), indicating the usual order of price, subject to market fluctuations:—

- | | | | | |
|----------|----------------------------|-----------------|---------------------|------------------|
| 1. | Olive oil. | 11. | Colza and rape oil. | |
| 2. | Sperm oil. | 12. | Seal oil. | |
| 3. | Neat's foot oil (genuine). | 13. | Niger seed oil | |
| 4 to 6. | { | Bottlenose oil. | 14. | Linseed oil. |
| | | Lard oil. | 15. | Whale oil. |
| | | Castor oil. | 16. | Cotton seed oil. |
| 7. | Cod oil. | 17. | Menhaden oil. | |
| 8 to 10. | { | Arachis oil. | 18. | Japan fish oil. |
| | | Sesamé oil. | 19. | Mineral oils. |
| | | Poppy seed oil. | 20. | Rosin oil. |

Olive Oil.—The natural variations in the quality of genuine oil of olives are much less marked than might *a priori* be expected, considering the wide range of country over which the olive is grown for the purpose of oil production, and the number of varieties that have been induced by centuries of cultivation in different climates and on different soils of the different species of *Olea*. Thus *O. europæa* (*var. sylvestris*) was alluded to by Dioscorides as a thorny tree growing wild (*Ἐλαια ἀγρία*); but losing its thorns by cultivation (like the sloe bush, the parent of the garden plums), giving the variety *O. europæa* (*var. sativa*) or *Ἐλαια ἡμερα*; which again has been the parent of numerous distinct kinds of olive trees producing fruit of very different sizes; thus the so-called "French" olive of the present day is much smaller than the "Spanish" olive. Apart, however, from these subspecies of *O. europæa* grown in Greece, Phœnicia,

* *E.g.*, Allen's *Commercial Organic Analysis*; Benedikt's *Analyse der Fette und Wachsarten*; the *Analyst*, *passim*, &c.

Palestine, and the south of Europe since the commencement of the historic period, and thence introduced and acclimatised into such parts of America, Australia, and elsewhere as possess suitable soils and climates, other oil-bearing species are utilised in other countries—*e.g.*, *O. ferruginea* (*O. cuspidata*) in Afghanistan and other Himalaya regions, and *O. capensis* at the Cape of Good Hope.

Even with the best known southern European varieties, notable differences in the quality of the oil extracted are found to exist according to circumstances, more especially according as the fruit has thoroughly ripened on the trees, or has been plucked before quite ripe and stored; and according as the oil has been extracted by gentle pressure in the cold, or by hot pressure, especially when accompanied by grinding processes whereby the stones are also broken up and expressed: indeed the differences in quality due to these causes appear to be quite as strongly marked as those due to soil, climate, and degree of cultivation. The finest qualities of all are obtained by handpicking olives from the trees, selecting those not over ripe, but ripe enough to allow oil to exude slightly on gentle pressure between the finger and thumb, and pressing very gently by hand in cloths: the "virgin oil" thus produced is subsequently agitated with water, and allowed to stand so as to remove mucilaginous matter, the purified oil being skimmed off. A slightly inferior, but still fine, grade of oil is obtained by crushing ripe olives (preferably with edge-stones, but without breaking up the olive kernels), and then pressing cold with comparatively little pressure. The residual marc (known in Italy as *Sanza* or *Nocciuolo*) is broken up, stirred with boiling water, and then pressed again with somewhat stronger pressure; the second marc (*Buccia*) is then ground again with heavier millstones so as to crush the olive stones (if this were not done at the first crushing), and is then again stirred up with boiling water and subjected to the heaviest pressure attainable with the appliances used: in small mills these are usually rough screw presses (p. 200, *et seq.*), but in larger ones hydraulic presses are employed (p. 207, *et seq.*) Finally, the residual oil (several per cents.) is extracted from the marc by means of carbon disulphide or other solvents (p. 231). The details of the processes used for extracting olive oil vary widely in different districts and countries; thus in some establishments the stones are separated from the pericarp and the two treated separately; a superior oil is thus obtained from the pulp, whilst "olive kernel oil" is extracted from the stones by grinding them to a coarse meal and then pressing or treating with carbon disulphide, &c. Excepting in being darker coloured and more unpleasantly smelling, the oil thus obtained is said not to differ materially from the lower grade oils obtained from the fruit pulp; it often contains a large percentage of free fatty acids

rendering it more readily soluble in alcohol than ordinary olive oil, thus resembling the "huiles tournantes" derived from the pulp (*infra*).

In this kind of fashion several qualities of olive oil are ultimately obtained, more especially "virgin" and "salad" oils of finest flavour, generally greenish through presence of chlorophyll, and of specific gravity near to .916 at 15°; "huiles d'enfer,"* or somewhat lower grades of inferior flavour (sometimes with more or less marked acrid aftertaste and disagreeable odour); "pyrene" and "sulphocarbon" oils (the former obtained by hot pressing and the latter extracted by carbon disulphide or other solvent) generally unfit for edible purposes, brownish yellow, and of specific gravity .920 to .925 at 15°; and "huiles tournantes" obtained from more or less fermented stored fruit, and in consequence considerably rancid, and containing large amounts (25 to 30 per cent.) of free fatty acids. The denser varieties deposit solid matters (mostly palmitin) on chilling somewhat sooner than the lighter ones.

The total acid number of various grades of olive oil has been found by different authorities to lie between 185 and 206, corresponding with the saponification equivalent 272 to 303; the better grades, however, generally furnish a total acid number near to 191 (saponification equivalent 294), and an iodine number near to 83.† Any considerable addition of rape oil would raise the saponification equivalent materially, whilst admixture with poppy seed oil, and to a lesser extent with sesamé, cotton seed, and rape oils, distinctly increases the iodine number. Maumené's test (p. 147) indicates a smaller degree of heat evolution on mixing with sulphuric acid in the case of olive oil than with most other oils; so that by making comparative experiments with pure olive oil and the substance examined side by side, indications of want of purity are obtainable; lard oil, however, gives about the same heat evolution as olive oil. Sophistication with arachis oil is moderately easily detected thus,‡ although many other tests fail to show its presence.

* So-called because the oil (mixed with water to separate mucilage by standing) is stored in large underground tanks or reservoirs so as to avoid exposure to air as much as possible.

† Olive oil usually consists of one-fourth glycerides of solid saturated acids (palmitic, &c.), and three-fourths liquid glycerides, mostly olein. This composition would correspond with an iodine absorption of about 67; the somewhat higher values usually found consequently suggest the presence of a small quantity of linolic acid. In confirmation of this, Hazura and Grüssner have obtained small quantities of sativic acid (p. 128) from the products of oxidation of the fatty acids of olive oil.

‡ Renard's test for groundnut oil is said by A. H. Allen to be sufficiently delicate to indicate clearly an admixture of 10 per cent. of that substance with olive oil, although failing with only 4 per cent. The small quantity of arachin naturally contained in olive oil does not materially interfere. The oil to be examined is saponified and the fatty acids separated and

Admixture with heavier oils, such as cotton seed oil, tends to raise the specific gravity; whilst, conversely, addition of rape oil tends to lower it; thus Souchère gives the following table indicating the effect of such admixtures on the relative density at 15° of pure olive oil:—

Oil.	Specific Gravity at 15° of Pure OIL	Percentage Added.				
		10	20	30	40	50
Olive, . . .	·9153
Colza, . . .	·9142	·91519	·91508	·91497	·91486	·91475
Sesamé, . .	·9225	·91602	·91674	·91741	·91818	·91890
Cotton seed,	·923	·91607	·91684	·91761	·91838	·91915
Arachis, . .	·917	·91547	·91564	·91581	·91598	·91615

The elaidin test (p. 137) serves to distinguish adulteration with many oils giving soft elaidins; a distinct softening of the product as compared with that obtained with pure oil treated side by side is noticeable when only a few per cents. of poppy seed or linseed oil are present, and with somewhat larger proportions of cotton seed, rape seed, or sesamé oil; moreover, the elaidin formed with pure olive oil is nearly colourless or pale yellow, whereas much darker tints are generally produced with adulterated oils; based on which property are numerous modifications of the nitric acid test proposed by various observers for the purpose of examining olive oil.

Examination of the cohesion figure (p. 48), formed when oil is placed on water, has been recommended by Tomlinson as a useful test of the purity of olive oil. A drop of oil is allowed to fall gently on the surface of pure water contained in a chemically clean basin of sufficiently large size, at a temperature not below 15° C.; with pure olive oil the drop slowly spreads out into the shape of a large disc with slightly recurved edges; little spaces shortly appear round the edge, the film commencing to retract again, so that the edge resembles a string of beads. The spaces between the beads soon open out more, and the edge becomes toothed; portions become detached, reuniting themselves in some

dissolved in five parts of rectified spirit, and precipitated with alcoholic lead acetate; or the oil is directly saponified with litharge by boiling with that substance and water. The resulting lead soaps are agitated several times with ether to dissolve out lead oleate (hypogæate, &c.); the residual lead stearate, palmitate, and arachate are decomposed by hot dilute hydrochloric acid, and the fatty acid cake formed on cooling and standing, dissolved in five parts of hot rectified spirit per one of original oil. On cooling, crystals of arachic acid are deposited if earthnut oil were originally present; from the weight of these, corrected for solubility in the mother liquors, an approximate notion of the proportion of earthnut oil present can be deduced, on the assumption that 100 parts of this oil correspond with five of arachic acid.

places to the main oil film enclosing polygonal spaces bounded by fine beads, and covered by a dew of oil so fine as to be visible only with difficulty. About 35 seconds are requisite for the entire succession of changes. With sesamé oil the film first formed soon begins to contract again, ultimately forming a figure consisting of a central spot with distinctly marked rays, between which other smaller rayed spots appear, the whole resembling a spider's web loaded with dew; about 60 seconds are required to complete these changes. Mixtures of olive and sesamé oils give figures of intermediate character, the features of the one or the other figure predominating according as the first or the second oil forms the majority of the mixture; and analogous differences in the olive oil figure are produced by admixture with other oils.

Baudouin's test for the presence of sesamé oil is to shake up 10 c.c. of the sample for some minutes with 5 c.c. of hydrochloric acid, specific gravity 1.17, in which 0.1 gramme of sugar has been dissolved. On separation of the oil from the watery liquid, the latter is found to be tinted rose colour, more or less marked according to the proportion of sesamé oil present. As little as 1 per cent. may be thus detected if the agitation be prolonged *for at least ten minutes* (A. H. Allen). Or a lump of sugar on which fuming hydrochloric acid has been dropped may be shaken up with the oil. On the other hand, according to Villavecchia and Fabris,* olive oil of undoubted purity from various localities in Italy gives the same red coloration to the aqueous layer as other oil to which some 5 per cent. of sesamé oil has been added; but if the agitation be only kept up for one minute, in the case of such pure olive oils, the watery layer immediately separates and remains colourless for at least two minutes; whilst the milky oily layer remains greenish or yellowish. If only a minute quantity of sesamé oil be present, however, this oily layer turns red; the coloration of the oil, rather than of the watery fluid, is the distinctive part of the test (*vide* also p. 153).

Becchi's test (p. 306) for cotton seed oil gives useful indications of the presence of that adulterant, provided that the refining of the cotton seed oil has not been carried so far as to bring about the entire withdrawal of the constituent that acts on the silver nitrate.

In many cases evidence of adulteration is obtainable by saponifying the oil, separating the fatty acids, and determining their fusing and solidifying points (p. 69) *side by side with the corresponding acids obtained from genuine oil, or mixtures of known composition*, as the precise numbers obtained vary according to the particular mode of manipulation adopted. Values varying from 22° to 29° C. for the fusing point, and from 21° to 25° as

* *Journ. Soc. Chem. Ind.*, 1893, p. 67.

the solidifying point, have been recorded by different observers. Dieterich gives the following comparative values in different cases, using the same process throughout:—

	Melting Point.	Solidification Point.
Olive oil (average of 19 samples), . . .	26° to 28°·5	23°·5 to 24°·6
3 parts olive oil to 1 of arachis oil, . .	29	26
" " cotton seed oil, . . .	30	27·3
" " sunflower seed oil, . . .	25	20·5
" " sesamé oil, . . .	28	25
" " linseed oil, . . .	24·5	19·5
" " colza oil, . . .	23 0	19

The figures thus deduced, however, are rarely sufficiently decisive of themselves to warrant any accurate deduction being drawn as to the nature and extent of the adulteration.

Much the same remark applies to tests based on the amount of solubility in various menstrua—*e.g.*, mixtures of alcohol, water, and glacial acetic acid (Valenta's test, p. 55), although in certain cases this method gives useful corroborative indications, especially when carried out side by side with genuine oil and mixtures of known characters.

Admixtures of hydrocarbons may be detected by completely saponifying the oil with alcoholic soda or potash, evaporating off most of the spirit and adding water, shaking up with ether, separating the ethereal liquid and evaporating off the solvent; with pure oil only infinitesimal amounts of unsaponified matter (phytosterol, &c.) will be left, whereas hydrocarbon oils, if present, will be obtained in much larger quantity after evaporation of the ether. This test may be made a quantitative one by using a weighed amount of oil and evaporating a known fraction of the ethereal solution in a weighed vessel (*vide* p. 119).

Occasionally metallic compounds are found in solution in olive oil or substances purporting to be such; thus copper (added to communicate a chlorophyll-like green shade) is occasionally present. Lead compounds are said to be occasionally added for the purpose of communicating a sweeter taste to the oil. Metallic impurities of this kind may be detected as described on p. 122.

Several special instruments have been invented for the purpose of examining olive oil, in order to detect adulterations, based on different physical properties—*e.g.*, the *thermal aræometer* (p. 82); the *oleorefractometer* (p. 51); and the *diagoneter* (p. 53). The polariscope may also be utilised, olive oil being slightly dextrogyrate, and most other oils lævogyrate.

Very similar processes suffice (*mutatis mutandis*) for the examination of other oils of the olive class—*e.g.*, almond oil, oil of ben (or behen), and groundnut (arachis) oil—and to some extent of oils of the semidrying class, such as cotton seed oil and

sesamé oil. With the cheaper oils of this kind, hydrocarbons and deodorised fish oils are the most likely kinds of adulterants; the former are detected and determined as described on p. 119; the latter largely increase the heat evolution with sulphuric acid, and in some instances give special colour reactions with that acid and other reagents.

Rape Seed and Colza Oils.—Several species of *Brassica* exist, and several varieties of the rape plant have been developed by successive cultivations; the oils from these are generally termed indiscriminately “rape” or “colza” oils in Britain. On the Continent, however, the different kinds are still frequently distinguished by separate names. Thus Schädler divides these oils into three classes, viz. :—

Colza oil (Colzaöl or Kohlsaätöl) from the original plant, “kohlsaät” (*Brassica campestris*).

Rape seed oil (Rapsöl or Rapsamenöl) from a developed variety, “raps” (*Brassica campestris* var. *napus*, or *Brassica napus oleifera*).

Rübsen oil (Rüböl or Rübsenöl) from a different variety, “rübsen” (*Brassica campestris* var. *rapa*, or *Brassica rapa oleifera*).

Each class is further subdivided according as the plant is an annual or a biennial, the former yielding “summer oils,” and the latter “winter oils.” Thus—

Winter rape seed oil from winter raps (*Brassica napus oleifera biennis*).

Summer “ “ “ summer raps “ “ *annua*.

Winter rübsen oil from winter rübsen (*B. rapa oleifera biennis*).

Summer “ “ “ summer rübsen “ “ *annua*.

Brassica nigra and *Brassica alba* are now more usually designated *Sinapis nigra* and *Sinapis alba* respectively (black and white mustard), being plants different in many respects from the cole or kohl, the seeds of which (kohlsaät) furnish the term “colza” by corruption. Similarly, the allied *Brassica juncea* is now generally known as *Sinapis juncea*, and *Brassica chinensis* (Chinese cabbage) as *Sinapis chinensis*.

Cole or rape seed is largely cultivated in various parts of Europe, especially France, Belgium, Germany, and Hungary; also in Roumania, Russia, India, and China. Much is shipped from the Black Sea and Baltic ports, the expression being usually carried out in large mills after the fashion described in Chap. ix., the seeds being crushed between rollers, steamed to coagulate mucilage and increase fluidity, and subjected by hydraulic pressure before cooling.

The yield is usually from 30 to 45 per cent. according to the variety employed. Schädler gives the following averages :—

Summer rübsen and summer raps,	30 to 35 per cent.
Winter “ “ winter “	35 to 40 “
Winter colza,	35 to 45 “

Much mucilage accompanies the crude oil; this is generally eliminated by the sulphuric acid refining process (p. 259), in some cases supplemented by an alkaline treatment to get rid of free acid, injurious for lubricant purposes.

Rape seed oil usually exhibits a total acid number of 175 to 179, corresponding with the saponification equivalent, 320 to 325, the iodine number being 98·5 to 105.* The fatty acids isolated on saponification melt at 18° to 22°, whilst the specific gravity of the oil at 15° ordinarily lies between ·911 and ·9175. Accordingly, the usual result of adulteration with other fixed oils is a rise in specific gravity, and a fall in saponification equivalent. Linseed and other drying oils raise the iodine number; fish and drying oils increase the heat evolution on mixture with sulphuric acid. Thus Thomson and Ballantyne found the "specific temperature reaction" (water = 100) for rape oil to be between 125 and 144, whereas that for linseed oil was 270 to 349, cod liver oil giving 243 to 273, and menhaden oil 306 (p. 149). Pure rape seed oil is practically immiscible with glacial acetic acid at the ordinary temperature, and has a lower efflux velocity (higher viscosity), than most oils likely to be used as adulterants.

Hydrocarbon oils are detected in the usual way (p. 119).

Linseed Oil.—The oil expressed from the seeds of the flax plant (*Linum usitatissimum*) is generally known as linseed oil; usually it is extracted on the large scale in crushing mills by the process described in Chap. ix.; but small quantities are prepared for home consumption in different parts of the world, more especially Russia, on a much smaller scale. The seeds as found in commerce are rarely all of one kind, more or less considerable admixtures of the seeds of other plants being often present, the result of which occasionally is to seriously impair the quality of the oil; this sometimes arises from intentional admixture, more especially in the case of hemp seed, which is stated to be invariably added to the extent of 5 per cent. and upwards to all linseed shipped from the Black Sea ports; but quite as frequently it is accidental, on account of other plants being grown along with flax—*e.g.*, mustard and rape; this is more especially the case with the red variety of Indian seed. The presence of mustard seed in any considerable quantity is liable to render the oilcake acrid and unsuitable as a cattle food.

Linseed is chiefly imported from the Baltic ports, Russia (Black Sea), and India; but it is also grown in considerable quantity in various parts of Europe, especially Poland, in Egypt, and the Brazils. Seed grown in hotter climates is reputed to yield oil comparatively defective in drying power and of lighter colour than that produced in colder regions; possibly, however,

* Hence, some considerable amount of linolin or other drying glyceride must be present, since the iodine number of erucin is 72·4, and that of rapin (isomeride of ricinolein) 81·7.

this is chiefly due to admixture of other seed oils and not to actual differences in the oil contained in the flax seed. When subjected to pressure, some 20 to 22 per cent. of superior "cold drawn" oil can be extracted; in Poland, Russia, and other countries this is used as an article of food, being not unpleasantly tasting. Later runnings prepared by hot pressure are darker in colour and have a disagreeable acrid flavour, rendering them only suitable for technical purposes. If the seeds are expressed comparatively "green," much more watery mucilage accompanies the oil; after keeping some months they dry somewhat and a better yield of oil with a lessened admixture of vegetable extractive matter results. Schädler describes the average yield as being—

Cold pressed oil,	20 to 21 per cent.
Hot pressed oil,	27 to 28 „
Obtained by solvents,	32 to 33 „

The proportion of oil obtained, however, varies somewhat with the source of the seed; thus Italian linseed yields somewhat more than Russian, and white Indian some 2 per cent. more than red Indian. Again, the yield varies according as the seed has been allowed to ripen fully, or as the plant has been harvested earlier for the flax crop, in which case a smaller yield of oil is usually obtained.

In practice, pure linseed oil is never met with commercially, and can only be obtained by carefully handpicking the seed before expression. When freshly expressed, after refining by sulphuric acid (p. 259), it has a specific gravity at 15° of .932 to .937, averaging close to .935 (Allen): if any considerable admixture of rape or other lighter oil is present, the specific gravity falls to .930 and lower. If, on the other hand, the oil is old and has absorbed oxygen, the specific gravity is more or less considerably raised.

Linseed oil contains some 10 or 15 per cent. of glycerides of solid fatty acids (palmitin, myristin, &c.) The remaining liquid glycerides consist of those of oleic, linolic, linolenic, and isolinolenic acids, in the relative proportions 5, 15, 15, and 65 per cent. of the sum of the four (Hazura and Grüssner). The total acid number is variously stated by different observers at 189 to 195.2, corresponding with a saponification equivalent of 287 to 297, representing a mean molecular weight of fatty acids of 274 to 285. By directly titrating the acids prepared as carefully as possible to avoid oxidation, molecular weights varying between 282 and 295 have been observed in many cases; but perceptibly higher values up to 307 have been noticed in some instances, leading to the belief that a higher homologue of linolic acid, $C_{20}H_{36}O_2$, was present (p. 34).

The iodine number of linseed oil has been very variously stated by different observers. Dieterich found different samples to give

values between 161·9 and 180·9; Benedikt found 170 to 181; Holde 179 to 180; Thomson and Ballantyne 175·5 to 187·7 according to the time allowed (*vide* p. 180). Lower values down to 149 have been recorded by other observers; but in view of the results of later researches on the difficulty of completely saturating glycerides with iodine unless a considerable time is allowed and a large excess of iodine employed, it would seem very doubtful whether these lower values are correct: probably 180 to 185 is nearer the true ultimate value for pure linseed oil.*

The fatty acids separable from linseed oil have been found by various observers to melt at temperatures lying between 17° and 24°, solidifying at 13° to 17°·5; as linseed oil occurs in commerce, a small proportion of these acids is usually present in the free state, free acid numbers being obtained varying from 0·7 to 8·0, corresponding with amounts of free acid from 0·4 to upwards of 4 per cent. of the total acids present.

Linseed oil is especially characterised by the high heat evolution brought about by admixture with sulphuric acid (Maumené's test, p. 147); in the absence of fish oils, any considerable admixture of rape or other oil giving less heat evolution can be readily detected in this way. Livache's test (p. 133) also affords an indication as to whether semidrying oils or drying oils of inferior quality have been admixed, inasmuch as the increment of weight after a few days, when no further increase is noticeable, is from 14 to 15 per cent. in the case of fresh genuine linseed oil, but considerably less if any large admixture of other oils be present. A simpler test based on the shorter time required by genuine linseed oil to dry thoroughly, as compared with adulterated samples and other drying oils, is the "film test" described on p. 133; the character of the dried film formed is also taken into account, whether resinoid and brittle when cold, or hard and varnish-like but tough, or inclined to be readily broken up and crumbly; such a practical test, although not quantitative in character, is

* Assuming linseed oil to contain only 80 per cent. of unsaturated glycerides in the relative proportions given by Hazura and Grüssner (*supra*), the calculated iodine would be 192·05.

	Proportional Amount Present.		Iodine Number of Glyceride.		
Olein,	0·8 × ·05	×	86·20	=	3·45
Linolin,	0·8 × ·15	×	173·57	=	20·83
Linolenin,	0·8 × ·15	×	262·15	=	31·46
Isolinolenin,	0·8 × ·65	×	262·15	=	136·31
					<hr/> 192·05 <hr/> <hr/>

whence it would seem probable that the proportions of linolenin and isolinolenin deduced by Hazura and Grüssner are a little overstated, at least so far as these values are applicable to average qualities of oil.

often of great value.* Moreover, an old sample of oil that has already taken up some amount of oxygen, although by no means deteriorated for many ordinary applications thereby, would be indicated as of inferior quality by Livache's test if alone relied on: but would not be shown to be deficient in drying power by the "film test." Such an oil, however, would possess a lower iodine number than fresh oil, even if otherwise genuine, inasmuch as the oxygen taken up appears to be largely added on to the unsaturated carbon groups just as iodine is.

Fish oils (cod, menhaden, &c.) possess high thermal values by Maumene's test, and high iodine numbers, so that adulteration therewith is not indicated by either reaction. Boiling with caustic soda develops a peculiar reddish colour when these oils are present: chlorine gas blown through the oil causes a great darkening in tint not observed with pure linseed oil. The sulphuric acid test (p. 151) gives simply a dark brown clot with genuine linseed oil, but a reddish brown spot if fish oils are present.

Hydrocarbons are not unfrequently added as adulterants; of these, mineral oils lower the specific gravity, and rosin oils raise it, so that a suitable mixture of the two has little or no effect. The test described on p. 119 enables this admixture to be readily detected and the quantity determined; if any considerable amount is present the film test indicates the fact, as the film remains a long time sticky with only small quantities, and never properly hardens and dries with larger proportions.†

Rosin (colophony) is another adulterant often added along with other substances; to detect and determine this admixture the oil is dissolved in a little pure alcohol, and the free fatty acids and resin acids titrated by standard alkali; water is added to the neutral mass, and the glyceridic oils separated by gravitation or petroleum spirit (p. 118); the aqueous fluid is acidulated, the mixed fatty and resinous acids separated and weighed, and the resin determined therein, as in the case of rosin soaps (yellow soaps, Chap. XXI.)

Hemp seed oil is a frequent constituent of linseed oil, owing to the admixture of hemp seed with linseed before reaching the crushing mills; to detect such an admixture the oil is stirred with concentrated hydrochloric acid, when a more or less marked

* The film test is often modified by mixing the oil to be tested with three times its weight of white lead, so as to form a paint which is then applied by a brush to a clean surface; a precisely similar trial is made side by side with a standard sample of oil, and the rates of drying compared. If nondrying oils be present, even in only small quantity, the rate of drying is markedly slackened.

† Rosin oils, being strongly dextrogyrate, can be detected by the polariscope (p. 50), pure linseed oil being faintly levorotatory. Sesamé oil is also dextrorotatory; the sugar test (p. 346) serves to detect it if present.

green coloration is developed if hemp seed oil be present, pure linseed oil giving a yellow colour.

Sperm Oil.—Two varieties of sperm oil proper are obtained from the Cachelot whale (*Physeter macrocephalus*); one from the blubber by the ordinary processes of rendering, the other from the “head matter” or contents of the cranial cavities. This latter usually contains a larger proportion of solid constituents, so that on standing it soon becomes more or less pasty or semi-solid from the separation of spermaceti. This solid constituent also deposits from the blubber oil on standing and chilling, but to a somewhat lesser extent.

Sperm oil thus freed from spermaceti is pale yellow and nearly odourless when prepared at comparatively low temperatures from fresh blubber, &c.; although, like all other fish and blubber oils, possessed of a marked unpleasant smell and darker colour when extracted by greater heat from partly decomposed blubber. Its specific gravity at 15° usually lies between .875 and .884: it has but little tendency to become rancid, or to “gum” and thicken by exposure to air, whilst its viscosity is but little affected by change of temperature, so that it forms a valuable lubricating oil. Its total acid number lies between 123 and 147, averaging near 132, corresponding with the saponification equivalent 426;* its iodine number is near 84. The fatty acids obtained on saponification melt at near 13°, and possess an iodine number near 88, and the average molecular weight 281–294 (Allen—oleic acid = 282, physetoleic acid = 254). Their specific gravity at 15° is near .899; nitrous acid solidifies them readily.

On saponification sperm oil yields 60–63 per cent. of insoluble fatty acids, separated from the monohydric alcohol simultaneously formed which constitutes 39–41.5 per cent. (theoretical values for cetyl physetoleate, cetylic alcohol = 50.6 per cent., physetoleic acid 53.1 per cent.; for dodecetyl physetoleate, dodecetylic alcohol, 44.1 per cent., physetoleic acid, 60.2 per cent.)

Sperm oil is often adulterated with cheaper vegetable and animal oils, the presence of which is usually detected by the lowering of the percentage of alcoholiform constituents produced on saponification, and by the circumstance that the viscosity of genuine sperm oil is affected less by temperature variations than that of most other oils, so that if other oils be present the differences between the efflux viscosity rates (p. 94) at different temperatures (*e.g.*, 15°C., 50°C., and 100°C.) will be considerably increased. Further, such admixture tends to lower the saponification equivalent. Hydrocarbon oils increase the saponification equivalent and the amount of ether residue obtained by the process described on p. 119; but this residue, consisting largely of fluid hydrocarbons, is readily distinguishable from the alcoholiform residue obtained with pure sperm oil, more particularly by the

* Cetyl physetoleate = 478. Dodecetyl physetoleate = 422.

acetyl test (p. 186). Vegetable and animal glyceridic oils lead to the presence of more or less considerable amounts of glycerol in the products of saponification; genuine sperm oil gives but little. Fish and sharkliver oils give special colorations with sulphuric acid on account of the biliary constituents present.

Tallow.—The terms "tallow" and "suet," especially the former, are often used indiscriminately to denote both the solid adipose tissues of various quadrupeds (more particularly the ox and sheep), and the fatty matters thence rendered by suitable treatment so as to separate them from the nitrogenous cellular tissue; preferably, however, the term "suet" should only be applied to the untreated animal fatty tissues, whilst the word "tallow" should only imply the fatty matters thence extracted and freed from cell walls, &c. In this sense "tallow" includes the rendered fats obtained from the ox, sheep, goat, stag, and other quadrupeds, excluding the horse and hog, the fats from which are generally known as "horsegrease" (maresgrease) and "lard" respectively.

According to the breed, age, and sex of the cattle or sheep from which the tallow is obtained, the hardness of the substance varies; the mode of feeding and climate also produce variations; whilst, as in the case of hog's lard, the consistency of the product differs considerably with the part of the carcass furnishing the fatty tissue. These variations, however, so far as is known, do not affect the general character of the fat as regards its constitution; whether harder or softer it essentially consists of the glycerides of oleic, stearic, and palmitic acids, the former being present in the larger proportion the softer the fat. In general, veal tallow (from calves) is softer than that similarly obtained from oxen; whilst cow tallow and bull tallow are harder still: these are all generally included in the term "beef tallow." "Mutton tallow" from sheep (ewes and rams) is usually harder than beef tallow, but not invariably: "goat's tallow" (often included in mutton tallow) much resembles that substance. In the trade a variety of grades exist, in many cases known by special names either denoting the country from which the material is shipped ("River Plate tallow," "Australian tallow," "Russian tallow," &c.) or given for some other reason—*e.g.*, P. Y. C. tallow = Petersburg yellow candle (or prime yellow candle), a particular quality irrespective of source; "Prime Butchers' Association tallow," or "North American," mostly shipped from New York; "Western," imported from New Orleans: "tripe tallow" and "town tallow," grades usually softer and somewhat inferior because of admixture with waste dripping, kitchen grease, and other similar materials. In many cases large admixtures of other foreign substances are added—*e.g.*, cotton seed stearine; * woolgrease and Yorkshire grease, and

* According to R. Williams cotton seed oil is often used as an adulterant in the case of softer tallows (*vide Journ. Soc. Chem. Ind.*, 1888, p. 186).

the stearines thence obtained by distillation and pressure; bone grease; together with solid non-fatty matters such as China clay, whiting, starch, &c., the presence of which is easily recognised by applying a solvent and filtering (p. 123).

The specific gravity at 15° of tallow lies between 0.925 and 0.940, values between 0.925 and 0.929 being obtained with beef tallow, and somewhat higher ones, between 0.937 and 0.940, with mutton tallow (Hager). Dieterich found slightly higher values up to 0.952. The melting point and solidifying point vary considerably, 41° to 51° being recorded by different observers for the former, and a few degrees lower for the latter. The fatty acids obtained on saponification also vary similarly with the hardness—*i.e.*, the proportion of olein, the melting point being usually near 47° with tallow of good quality. The solidifying point as determined by Dalican's process (p. 74), sometimes termed the "titre" of the tallow, affords the best criterion of quality, so far as such physical tests go: 44° represents a mixture of equal quantities of stearic and oleic acids, lower values being obtained when oleic acid preponderates, and higher ones when stearic acid is in excess. On the Continent, it is often stipulated that the solidification point shall not fall below 44° when the tallow is intended for candlemaking; whereby not only are the softer genuine (or comparatively so) tallows excluded, but also those largely adulterated with such substances as cotton seed oil, cotton seed stearine, Yorkshire grease, stearine from distilled grease, &c., as the presence of these materials tends to lower the melting point of the mixed fatty acids obtained. Woolgrease and Yorkshire grease products are especially objectionable in this connection, because they contain more or less considerable quantities of cholesterol hydrocarbons and other unsaponifiable substances, which not only directly diminish the amount of stearic acid present, but also further diminish the quantity of solid fatty acids obtainable by pressing, as they interfere with the proper "seeding" or crystallisation of the press cake (*vide* p. 367). The determination of these unsaponifiable matters in tallow adulterated therewith, is carried out as described on p. 119.

Fresh tallow contains very little free fatty acid; but tallow that has become more or less rancid often contains considerable amounts, up to 12 per cent. (calculated as oleic acid); 25 per cent. was found by Deering in a sample six years old. When tallow is not particularly rancid, and yet contains a considerable amount of free acid, it is very probable that it has been adulterated with distilled "stearine" (largely consisting of free fatty acids). The total acid number usually lies between 193 and 198, representing the saponification equivalent 283 to 293, averaging near 288, and corresponding with a mean molecular weight of fatty acids of near 276 (palmitic acid = 256, oleic

acid = 282, stearic acid = 284). The iodine number has been found by different observers to lie between 35 and 45, with an average of about 40; since pure olein has the iodine number 86.2, this indicates an average amount of olein of somewhat less than 50 per cent. (about 46), and a proportion of solid glycerides of somewhat above 50 per cent. (about 54). According to the author's experience, in the absence of adulterations the determination of the iodine value can be made into a useful test of quality for candlemaking purposes, the proportion of solid fatty acids obtainable being greater the less the iodine absorption; but when pressed coker butter or palm kernel oil has been added, the iodine number is reduced without a corresponding increase in amount of solid fatty acids of high melting point obtainable; and the same remark applies to woolgrease, wool stearine, and similar substances. When circumstances permit, the best indications as to adulterations of this kind are obtained by saponifying, separating the fatty acids, allowing them to crystallise, and expressing them in a small experimental laboratory press, determining the quantity and melting point of the press cake, and subjecting the expressed oleic acid to examination as regards its iodine absorption, elaidin reaction, colour reactions with sulphuric and nitric acids, &c., heat evolution with sulphuric acid (Maumené's test, p. 147), amount of unsaponifiable matters present, and so on; samples of genuine tallow of different qualities being examined by side in the same way.

Muter and Koningh* recommend a process based on somewhat similar principles, where the solid and liquid fatty acids are separated by conversion into lead salts and solution of lead oleate, &c., by ether, wherein lead stearate and palmitate are but sparingly soluble. By carrying out the saponification and subsequent processes in a uniform prescribed way, the quantity and characters of the liquid fatty acids ultimately separated from the soluble lead salt, afford useful indications respecting adulteration. Thus, they found that the iodine number of the liquid acid obtainable from pure tallow, is uniformly close to 90, substantially identical with that theoretically requisite for pure oleic acid. Lard, on the other hand, gives a liquid acid possessing a distinctly higher iodine number, close to 93; whilst the liquid acids from cotton seed oil give a considerably higher iodine value, near to 135.

Tallow that has become rancid by keeping generally whitens during the process; owing to the large amount of decomposition with formation of free fatty acids that occurs (*supra*), such tallow is unsuitable for lubricating purposes; the byproducts of the decomposition, moreover, cause soap made from such tallow to "work foxy," or become discoloured of a brownish red, so that for milled or other toilet soaps intended to be white or tinted

* *Analyst*, 1889, p. 61; 1890.

delicate shades, such tallow should be avoided in the manufacture of the "stock soap" used.

Beeswax.—A good deal of dispute has taken place at various times as to whether the wax of the bee, wasp, and similar insects is a distinct product of secretion due to their own special life action, or is simply precontained in the pollen and nectar of flowers, &c., serving as their food, and isolated therefrom by digesting away or otherwise removing the other constituents. This latter view appears probable, inasmuch as when bees are fed upon sugar only, they appear to be incapable of developing wax to any notable extent. On the other hand, although the character of bee food necessarily varies much in different parts of the world, yet the chemical constitution of beeswax does not differ anything like so widely. Samples of beeswax from numerous localities in Europe, Asia, South America, and Australia, all possessed very similar compositions (Hehner*)—viz., they essentially consisted of a mixture of about 1 part of free cerotic acid to 6 of myricin (*vide infra*); a result hardly compatible with the notion that the wax pre-existed as such in the pollen and nectar of the very wide variety of flowers, &c., furnishing food to the bees in these different quarters of the globe. *Andaquia wax* (wax of *Apis fasciata*, largely used for candlemaking in South America) appears to be substantially identical with the ordinary beeswax of *Apis mellifera*; and the same remark applies to *Antilles wax* (*Apis fasciata*?), and to *Madagascar wax* (*Apis unicolor*), although frequently beeswax of tropical and subtropical origin is darker coloured and less readily bleached than that produced in more temperate climates.† The wax of the Eastern Archipelago, again, differs but little from that obtained from other sources, although mainly produced by a different species (*Apis dorsata*).

In order to obtain beeswax the combs are simply drained of honey and then melted in hot water and stirred about; the wax collects on the top as an oily layer, which is removed after cooling and hardening; after remelting by heat alone (without water) and casting into blocks, the "virgin" wax is ready for the market. A large proportion is used for numerous purposes without further preparation; for certain purposes bleaching is requisite, effected either by means of exposure to air and sunlight in thin shavings (p. 268), or by means of chemicals, preferably dilute sulphuric acid and potassium dichromate (p. 266).

Beeswax is readily soluble in carbon disulphide and fusel oil; it dissolves in about 10 parts of boiling ether, less completely in cold ether, benzene, or petroleum; in cold alcohol it is nearly

* *Vide Analyst*, 1883, vol. viii., p. 16.

† Wax from the vicinity of Bordeaux appears to be the variety most difficult to bleach; whether from some local peculiarity in the flowers frequented by the bees, or for some other reason, is unknown.

insoluble, but dissolves in about 300 parts of boiling spirit. In the case of most solvents, some parts of the wax dissolve much more freely than other portions; thus in the case of hot alcohol a small quantity of "cerolein" is left undissolved, consisting of fatty matter, principally palmitin and olein; the proportion of this constituent varies in waxes of different origin, but is never large, so that the presence of fatty glycerides in any quantity is only due to adulteration. Natural wax contains a considerable amount of free acid (from 12 to 16 per cent., calculated as cerotic acid—Hehner); that bleached by means of dichromate usually contains somewhat more (17 to 18 per cent.); but airbleaching appears to produce no measurable increase in the free acidity. The free acid in raw wax appears to be chiefly *cerotic acid*, $C_{27}H_{54}O_2$, together with a little *melissic acid*, $C_{30}H_{60}O_2$; by treating the wax with limited quantities of hot alcohol these are dissolved out, *myricin* (the palmitic ether of myricylic alcohol, $C_{30}H_{61} \cdot O \cdot C_{16}H_{31}O$) constituting the great majority of the undissolved part.

Beeswax has at 15° C. the specific gravity nearly .96 (numbers varying between .956 and .975 being recorded by different observers). At 98° to 99° the specific gravity is .818 to .827 (Allen). Airbleaching seems to produce little or no alteration in the density, but chemically bleached wax is usually rendered a little more dense by the process. The melting point is always close to 63°, values varying between 61° and 65° being recorded by numerous observers; the melted substance re-solidifies at one or two degrees lower than the temperature of complete fusion. The free acid number has been found by Hehner, Hübl, Buisine, and other observers to be subject to comparatively little variation, almost invariably lying between 17 and 21 in the case of unbleached wax, corresponding with 12.5 to 15.5 per cent. of cerotic acid); whilst the ester number (p. 162) lies between 72 and 76 (corresponding with 87 to 92 per cent. of myricin); the sum of the cerotic acid and myricin thus calculated is generally a little above 100, showing that some amount of other constituents of lower molecular weight is also present. In confirmation of this the iodine number has been found to be appreciable, though low, averaging about 10 (8.3 to 11.0, Buisine), indicating the presence of a perceptible amount of unsaturated compounds (possibly hydrocarbons). On saponification with continued boiling (for at least an hour) with excess of alcoholic potash, genuine beeswax furnishes 53 to 54 per cent. of crude myricylic alcohol (Benedikt), corresponding with 81.8 to 83.4 of myricin (myricylic palmitate).*

* Wax bleached by the air process is often admixed with a few per cents. of fatty matter which seems to facilitate the bleaching action in some way not thoroughly understood. A small quantity of oil of turpentine is sometimes added for the same reason; in this case the bleaching is probably

Beeswax is often largely adulterated, more especially with paraffin wax and allied hydrocarbons (cerasin and similar high-melting mineral waxes); stearic acid; colophony, burgundy pitch, and other similar resinous matters; and solid weighting materials, such as china clay, barium sulphate, yellow ochre, starch, and sulphur. Vegetable waxes (carnauba wax, &c.) are often added; and in some cases several per cents. of water are artfully worked into the mass. This last admixture is readily detected by the methods described in Chap. vi., p. 122. Mineral adulterations are readily detected by incinerating the wax and burning off carbonaceous matters so as to obtain the clay, &c., as residue. By dissolving in ether, warm oil of turpentine, chloroform, benzene, or other suitable solvent, these substances, as well as starchy matters, and other analogous adulterants, are left undissolved, and may be obtained by filtration and washing.* Stearic acid, if added in any quantity, is detected by the increased free acid number, and by the melting point and general characters of the acids ultimately obtained from the soap formed on shaking the wax with hot alcohol, and titrating with standard alkali and phenolphthalein (p. 118). Glycerides, similarly, may be detected and, to some extent, estimated by the formation of glycerol on saponification; whilst adulteration with carnauba wax may be detected by the examination of the fatty acids formed by saponifying the impure myricin left insoluble on agitation with alcohol and alkali, palmitic acid (m.p. 62°, and equivalent 256) being the chief constituent formed from genuine wax, whilst carnauba wax mostly produces cerotic acid (m.p. 79°, and equivalent 410). The presence of hydrocarbons is indicated by the decreased ester number; or the wax may be carbonised by heating 5 grammes with 50 c.c. of concentrated sulphuric acid to 130°C. in a capacious flask for ten minutes; much sulphurous acid, &c., is evolved, and the mass chars, finally becoming nearly solid; the acid is washed out with water, adherent water removed by alcohol, and the residue treated with ether, preferably in a Soxhlet tube (p. 238), whereby the hydrocarbon is dissolved out, along with a little wax that has escaped the action of the acid. By repeating the acid treatment this is removed, and the cerasin, &c., finally obtained in a weighable form.†

Spermaceti.—The true origin of spermaceti (formerly regarded as whale-spawn, *Sperma ceti*) appears to have been unknown,

quickened by the formation of peroxide of hydrogen during the oxidation of the turpentine by the oxygen of the air in contact with water (*vide* p. 269).

* Traces of flour are often normally present in pressed or rolled wax owing to the use of flour for dusting over the rollers or press to prevent the wax from sticking (Allen).

† Respecting the detection of adulterations of beeswax, *vide Journ. Soc. Chem. Ind.*, 1890, p. 771; 1891, pp. 728, 729, 860, 1014. For the bibliography of beeswax and the waxes used for its adulteration, *vide ibid.*, 1892, pp. 756, 757.

long after it had come into some amount of use for the preparation of unguents; its employment for candlemaking, like that of whale oils for burning in lamps, seems practically to date from somewhat upwards of a century ago when the whale fishery began to be extensively pursued for commercial purposes. Even at the present day, however, considerable misapprehension appears to exist both as to the species of cetacea yielding it and the part of the body from which it is derived. Whilst the best known source is the "head matter" of the *Physeter macrocephalus* (p. 300), which largely consists of solid crystallised spermaceti when taken from the dead carcase, it is also the fact that considerable quantities are obtainable from the blubber oil of the same cetacean; during winter this oil sets so far solid by deposition of spermaceti that it requires to be steamed to enable it to be removed from the casks. Moreover, analogous if not identical solid deposits form on similarly chilling for lengthened periods the blubber oils of various other species (*vide* p. 301).

The semisolid oils containing scales of spermaceti will not bear any great degree of pressure during filtration to separate the solid matter, as this very readily passes through even the most impervious filter cloths: accordingly the first operation consists of "bagging"—i.e., the material is placed inside long bags of hair or canvas where gravitation only effects a separation between the solid and liquid constituents. The "bagged sperm" is then transferred to square bags, forming a soft flaky mass: a pile of bags and boards is formed in successive alternate layers, and by placing weights on the top of the pile, at first small but subsequently greater, most of the remaining fluid oil is gradually squeezed out until the mass is sufficiently firm to bear hydraulic cold pressure carried out in presses closely akin to those used for stearine. After cold pressing, the sperm cake is remelted, granulated, and pressed several times over at gradually increasing pressures and temperatures so as to remove the last portions of fluid oil, a refining treatment with potash (p. 261) being interpolated between the last pressings so as to remove not only the last traces of colouring matter, but also free fatty acids formed by hydrolysis. Finally, a glistening white mass is obtained, mainly consisting of cetylic palmitate ($C_{16}H_{31} \cdot O \cdot C_{16}H_{33}O$), melting at near $45^{\circ}C.$,* and of specific gravity near $\cdot 810$ at 99° .

The pressings from these various operations are methodically worked up, in such fashion as ultimately to obtain a second quality of spermaceti of somewhat lower melting point: the potash foots obtained during refining yield on acidulation with a mineral acid a mixture of impure spermaceti and palmitic acid;

* According to L. Field (*Journ. Soc. Arts*, vol. xxxi., p. 840), the spermaceti extracted from the blubber oils of the true bottlenose whale (*Balena rostrata*) has a slightly higher melting point than that from the sperm whale or cachelot (*Physeter macrocephalus*).

when this is worked up with the other runnings a considerable amount of free fatty acids is contained in the ultimate product. 30 per cent. and upwards of such free acids (essentially palmitic acid) are sometimes present in spermaceti of this lower grade.

Spermaceti is sometimes adulterated with free stearic and palmitic acids (not derived from the foets, as above described), hard pressed glycerides (pressed tallow), and animal waxes and paraffin wax. These latter additions raise the saponification equivalent, whilst free fatty acids and glycerides lower it. The detection of these adulterants is effected in ways substantially the same as those above mentioned with respect to beeswax.

§ 6. The Candle Industry.

CHAPTER XVI.

MATERIALS USED IN CANDLEMAKING.

ORIGIN OF CANDLES.

IN all probability the earliest forms of illuminating agents of the nature of *candles* (*i.e.*, containing something serving the purpose of wick surrounded by more or less solid combustible matter adherent thereto) were simple links or flambeaux consisting of fibrous vegetable stalks, &c., soaked in natural bitumen or asphalt, vegetable resin, or animal fatty matter; these being obvious developments of the yet simpler primeval torches consisting of splinters of pine and similar woods, either naturally full of resinous matter, or externally smeared therewith.

Lamps, or reservoirs of fluid oil furnished with a wick for burning, seem to have been invented at a very early period of the world's history, and to have speedily superseded the primeval resinous wooden torch for general household purposes amongst the earlier civilised nations, although for outdoor illuminations, and especially amongst the Scandinavians and other northern tribes, pine splinter torches and similar rude contrivances of the flambeau character were still chiefly used.

Rushlights, where the pith of rushes served as wick and where the combustible matter was tallow or other animal fat applied by dipping the pith in melted grease, and superior forms where wax was used instead of tallow, moulded by hand round the rush whilst rendered plastic by means of warmth,* appear to have been in considerable use amongst the Romans, hempen or flaxen unspun wicks taking the place of rush pith in the better kinds of wax lights; thus in Herculaneum the remains of a chandler's establishment have been unearthed, whilst numerous passages in various Latin authors indicate that the torch (*tæda*), the lamp (*lucerna*), the tallow candle or rushlight (*sebaceus*), and the wax

* Such a candle, believed to date from the 1st century, is in the British Museum.

light (*cereus*) were all in use in the early centuries of the Christian era;* the oil lamp being still the most extensively used illuminant amongst the well to do classes, wax lights ranking next.

With the exception that wax tapers were largely used for ecclesiastical purposes, as well as private illumination, during the middle ages, and that some improvements were consequently introduced as regards their general size and finish, little advance in the art of candlemaking seems to have been brought about until the fifteenth century, when the process of "moulding" was introduced by the *Sieur de Brez*; but the manufacture of rushlights and of "dip" tallow candles, as well as of waxen tapers, had by that time become a trade of itself, having to a considerable extent passed out of the region of ordinary household operations carried on by each family for the supply of its own wants, and into the hands of special candlemakers (*candelarii*, or *chandlers*), who made tallow and other candles for sale to the general public, at any rate in the larger towns. In country districts, however, rushlights and tallow candles, of more or less rough home-made manufacture, still continued to be the only available means of artificial illumination other than oil lamps, for the great majority of the population; a state of matters, indeed, not entirely obsolete even at the present day in some highly rural localities. In some savage countries highly oleiferous nuts, strung together on a fibrous twig, are burnt like candles; as one is consumed the next one becomes lighted and burns till exhausted.

Combustible Materials.—At the present time the combustible matters (in addition to the wicks) used for candlemaking may be divided into four classes—viz., (1) those natural glycerides which are sufficiently solid at ordinary temperatures to admit of being used for the purpose, or which yield sufficiently solid glycerides by pressure; more especially tallow and similar animal fats, together with vegetable products of corresponding consistency, such as coker stearine, piney tallow, and the solid fats of the *Stillingia*, *Bassia*, and other genera. (2) Substances of waxy character, such as beeswax and the vegetable waxes, essentially consisting of nonglyceridic compound ethers; also including spermaceti. (3) Free fatty acids of sufficiently high melting point, obtained from natural oils and fats by saponification processes, and mechanical separation of more fluid ingredients. (4) Paraffin wax and analogous hydrocarbons of mineral origin, or formed by destructive distillation. Of these the substances of the latter two classes are those most largely used, more especially the last, in this country, although "stearine" candles are somewhat preferred on the Continent. The trade in wax and spermaceti candles is comparatively small, although by no means insigni-

* *Vide* Leopold Field, "Cantor Lectures," *Journ. Soc. Arts*, vol. xxxii., p. 821, *et seq.*

ficant in actual amount ; whilst the use of unsaponified glycerides, whether as tallow "dip" candles, consisting of such glycerides only, or as "composite" mixtures of glycerides and free fatty acids, is steadily diminishing in favour of the other kinds of illuminants, although far from being extinct, especially in the case of nightlights, which are largely made of coker stearine.

In the manufacture of tallow dip candles no special preparation of the tallow for use is requisite further than the rendering and purifying processes already described (Chaps. x. and xi.) ; the harder varieties are usually preferred, although if too hard there is more risk of cracking. In the case of beeswax, air and light-bleached wax (p. 268) is employed in preference to that bleached by chemical processes, especially such as involve the use of chlorine ; for, irrespective of a greater tendency to become yellowish on keeping, such chemically bleached waxes are apt to possess a crystalline grain which spoils the appearance of the candle, and when bleached by chlorine, to give off fumes of hydrochloric acid when burnt, owing to the formation of chloro-substitution compounds during the bleaching process. Paraffin wax and the analogous waxy hydrocarbons obtained from ozokerite, &c., require no further treatment for candlemaking other than the pressing and purifying processes gone through during their manufacture for the purpose of raising the melting point to the requisite extent (compare p. 230). The isolation of solid free fatty acids from natural glycerides, however, is a somewhat complex operation capable of being carried out in several ways.

MANUFACTURE OF "STEARINE."

The numerous processes proposed, and more or less actually used on a manufacturing scale for the isolation of solid fatty acids from appropriate glycerides, may be classified under the following heads :—

1. Processes where the glycerides are saponified by alkalis, alkaline earths (such as lime), or other suitable basic materials, by boiling under ordinary pressure ; to effect which operation a more or less considerable excess of base is usually found necessary in order to complete the saponification.

2. Processes analogous to the preceding, except that the operation is carried out at a somewhat higher temperature obtained under increased pressure ; excess of base is in this case unnecessary, for, in general, practically complete saponification and hydrolysis can be thus easily brought about even when considerably less base is present than is chemically equivalent to the fatty acids formed, and although the temperature does not rise sufficiently high to decompose any considerable fraction of the glycerol set free.

3. Processes where hydrolysis is effected under the influence of acids, especially sulphuric acid; in this case the liberated acids are usually distilled over by the aid of superheated steam, so as to separate them from nonvolatile pitchy matters formed as bye products; in Bock's process (*infra*) this distillation is unnecessary. More or less glycerol is usually destroyed by the action of the acid.

4. Processes where hydrolysis is brought about under the influence of water alone (under great pressure, or as highly superheated steam). In these processes the glycerol is often largely destroyed by the heat (sometimes completely so), a much higher temperature being requisite than in the case of methods of the second class.

The Chevreul-Milly Process—Alkaline Saponification Process in Open Pans under Ordinary Pressure.—The first attempts to utilise solid free fatty acids for candle material, were made about 1825 by Chevreul and Gay Lussac, employing alkalies (potash and soda) to effect the saponification of tallow; for a variety of reasons, this process proved to be commercially a failure; but a few years later, by substituting lime for alkalies and otherwise employing more suitable arrangements, M. de Milly succeeded in making the manufacture of "stearine" candles from tallow a sufficiently remunerative undertaking to render it a practical industry. As carried out at the present day, the process differs little in essential points from what it was more than half a century ago, the chief differences lying in the scale on which the operations are effected, and the frequent use of mixtures of vegetable and other substances with tallow (*e.g.*, a mixture of palm oil and tallow or other suitable fatty matters) instead of tallow only,* a better quality of mixed fatty acids being thereby usually obtained—*i.e.*, a mixture which allows the solid acids to crystallise and "granulate" more readily, so as to be more easily pressed for the separation of liquid acids.

The fatty matters being generally purchased in casks, by means of a steam jet applied at the bung-hole, the fats are melted out into a tank, whence they are pumped or run by gravitation into the decomposing pan, usually constructed of wooden staves (preferably of oak) strongly bound together, and forming a large tub or tun, sometimes lined with sheet lead. This is provided with a stirring arrangement, consisting of a central vertical shaft with arms carrying paddles and rakes, so as to intermix the contents thoroughly (Fig. 78). Quicklime, in the proportion of 12 to 15 pounds per 100 of fat, is mixed with water to a cream and run into the tun,† and the whole heated up by steam blown

* In France the use of palm oil is much less frequent than in Britain, thus leading to some slight differences between many kinds of French "stearine," as compared with British.

† Assuming the mixture of fatty matters to have a mean saponification

in through a perforated horizontal coil at the bottom of the tub, or a series of jets distributed over the bottom, and the whole kept agitated for some hours, a cover being placed over the

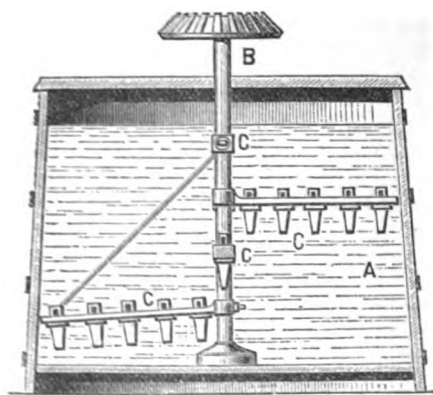

Fig. 78.

tub to keep in splashes, and steam being blown through gently so as to keep the whole boiling. Glycerol is thus set free, and a mixture of lime-salts formed (mostly stearate, palmitate, and oleate), practically insoluble in water, and solidifying on cooling to a hard mass known as "rock;" the aqueous glycerol solution or "sweet water" is run off and utilised for glycerol extraction. To isolate the fatty acids, the rock is boiled up in a lead-lined vat with steam, diluted sulphuric acid being added in slight excess of the quantity requisite to saturate all the lime present.* Sulphate of calcium separates out, whilst the free fatty acids swim up to the top; after standing and cooling somewhat, these are skimmed off and boiled up, firstly with highly dilute sulphuric acid to decompose the last traces of lime soap, and then with water, using wet steam, so as thoroughly to wash out all sulphuric acid and admixed mineral matters. Finally, the fluid fatty acids are transferred to shallow cooling pans, such as the series indicated in Figs. 79 and 80. Here the melted fatty acids are run from a trough, F, through nozzles, D D D, into the uppermost of the pans, C C C, supported by a wooden framework, A A, and iron crossbars, B B B. When the pans are filled, the stream of melted

equivalent of 280, the quantity of lime (CaO) theoretically equivalent to the fatty acids formed would be 28 parts per 280, or 10 per cent.; with fatty matters of higher saponification equivalent, proportionately less lime would be required, and vice versa. Some excess of lime, however, is requisite in order to ensure tolerably complete action; moreover, in practice, quicklime is not pure CaO, a little moisture, calcium carbonate, and more or less siliceous and clayey matter being present, all of which are inert so far as effecting saponification is concerned. A first class quicklime, made from a pure limestone, may contain (when freshly burnt) some 95 per cent. of CaO (exclusive of calcium carbonate); but 85 to 90 per cent. is more nearly the usual average, and less with very poor limes.

* For every 56 parts of actual lime, CaO, used, 98 parts of actual sulphuric acid, H₂SO₄, are required; roughly, 2 parts of B.O.V. (brown oil of vitriol) to 1 of quicklime.

matter is shut off by means of the spigot, E. In these cooling pans they solidify to a semicrystalline mass on cooling and standing; for the purpose of pressing out the fluid acids, this solidification is best allowed to take place in metal dishes, so that the solid cakes formed are obtained in the form of slabs about an inch or three-fourths inch thick, and of such size as to fit into the cake boxes of the hydraulic press used; the temperature during

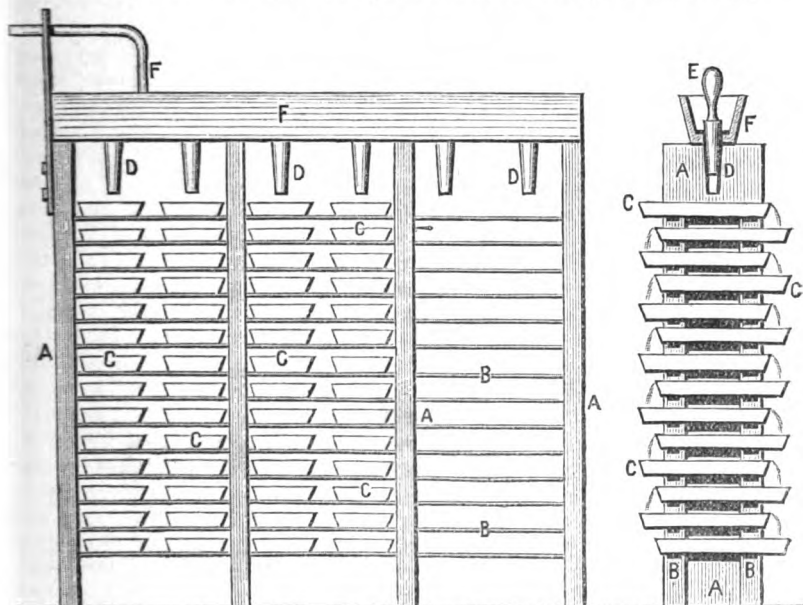

Fig. 79.

Fig. 80.

this period should lie between 21° and 32° C. (70° to 90° F.), so that whilst the "seeding" or crystallisation of the solid acids (mostly stearic and palmitic) may take place completely, as little oleic acid as possible may be retained in the body of the crystals formed. The slabs of "separation cake" finally consist of a spongy mass of granular or crystallised solid acids, with liquid oleic acid (containing solid acids and colouring matters in solution) disseminated through the interstices. By enveloping them in press cloths, and placing them in the cake boxes of a hydraulic press, the brownish liquid acids are gradually squeezed out, and the comparatively colourless solid crystals retained. Instead of directly pressing the granulated cakes, it is often preferable to rasp them into shreds by a machine, and to press the raspings; a more complete expression of liquid acids is thus brought about. The press cake left, however, still retains a certain amount of

liquid acids, rendering its fusing point too low; to remove these the press cakes are melted by steam, cast afresh into slabs in shallow trays, allowed to stand to granulate at a temperature of about 30°C ., rasped to coarse powder, and again pressed in a different machine where the cake boxes are heated by the regulated admission of steam into the plates, in the body of which channels are hollowed out for the purpose. Fig. 81 represents a form of horizontal hot press thus arranged, steam being admitted to the plates by the pipes, E E. A A A represent the packets of raspings undergoing pressure; B the piston of the hydraulic ram working in the cylinder, C; D the framework; F a chain whereby the plates are drawn asunder for the removal of the cakes when the operation is finished; G water supply pipe to ram cylinder from accumulator. The temperature of the hot press varies somewhat with the kind of material employed, but is generally not far from 50° (122°F .) for stearine of high

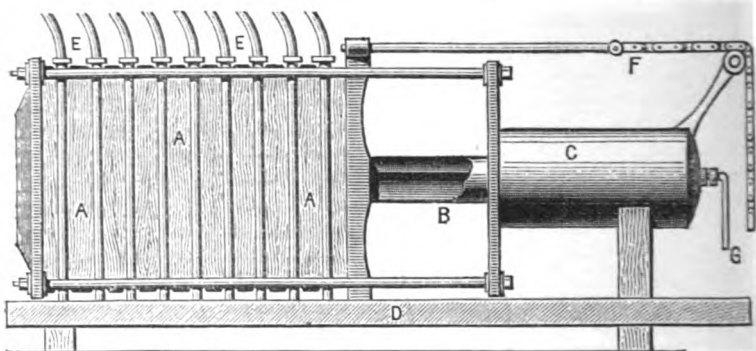

Fig. 81.

melting point; for inferior stearine melting more easily, the temperature is proportionately lower.

The hot press cake finally obtained is melted by means of steam along with a little water acidulated with sulphuric acid, and then vigorously agitated with the acid fluid for some time for the purpose of removing traces of lime salts still retained; finally the acid liquor is run off, and several successive boilings-up carried out with plain water. The purified mixture of stearic and palmitic acids is then cast into blocks for use in the candle factory; small quantities of vegetable wax, beeswax, &c., are sometimes added to "break the grain"—i.e., to prevent the formation of visibly large crystals during solidification.

Even when the fatty matters employed are highly rancid and impure, an almost perfectly white "stearine" can be thus manufactured by the lime process. The yield of pure solid hot pressed acids, however, is materially influenced by the presence and

nature of abnormally large proportions of oleine (existing in softer fats, &c.) or other substances (*e.g.*, woolgrease), not only on account of the diminution in amount of solid fat acids present, but also because of the increased amount of these acids removed in the "red oils" (*vide infra*).

Fig. 82 represents a general view of the disposition of the apparatus used in the saponification of fatty matters by the open pan process.* A, tub from which lime is emitted. B, leadlined vats with steam pipes for boiling lime and fats. C, similar decomposing vats where the rock is boiled with sulphuric acid. D D, rack holding pans for caking mixed acids. E, cold press. F, hydraulic pumps. G, pan for remelting press cake. H, hot press. I, vat for melting hot pressed stearine for final washing with water and casting into blocks.

Moinier and Boutigny modify the Chevreul-Milly process by submitting the melted tallow, &c., to a preliminary treatment with hot water and a current of impure sulphur dioxide (produced by the action of hot sulphuric acid on sawdust, charcoal, &c.); after an hour the lime-cream is added and the whole well agitated, whereby the mass increases in consistence with considerable frothing, by and bye becoming pasty.

The sulphur dioxide is then shut off and the rock finished by boiling up with steam, &c., as usual. The yield of fatty acids is stated to be thus increased

* L. Field, *Journ. Soc. Arts*, vol. xxxi., p. 859.

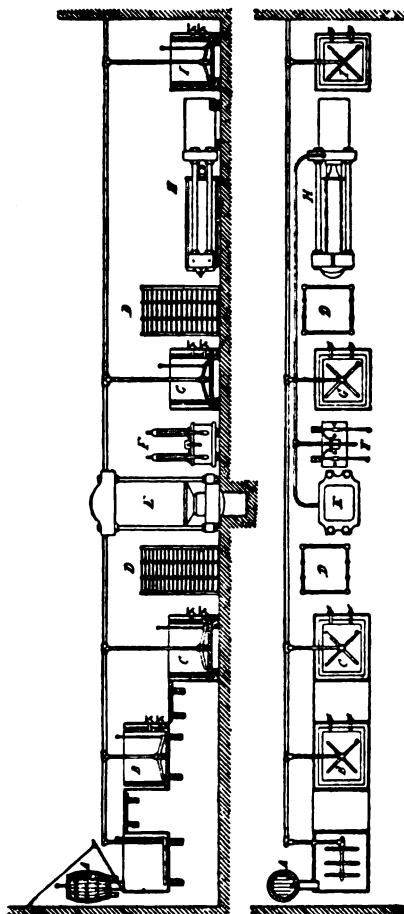

Fig. 82.

by some 4 per cent. The hot press cake is finally refined by boiling up first with water acidulated with sulphuric acid, then with water alone, white of egg (1 egg per 100 lbs.) being introduced whilst boiling so as to coagulate and remove impurities as in clarifying coffee, &c.

On p. 375 are given some analyses of original fatty acid mixture, cold press cake, and hot press cake, &c., illustrating the effect of the process in separating oleic acid from the solid fatty acids, and the increment in melting point thus effected. The hot press grease usually contains enough solid fatty acids to raise its fusing point to at least that of the original mixture of fatty acids before cold pressing; it is generally worked up along with fresh fatty acids by fusing therewith and granulating the mixture in trays for the cold press. The outer edges of the hot press cake retain some amount of more fusible grease, and are therefore usually pared off and worked up along with the rest of the hot press grease.

The "red oil" or "oleine" running from the cold press contains a considerable quantity of palmitic and stearic acids in solution, the precise amount depending on the temperature at which the pressing is conducted; on chilling somewhat, more or less solid fatty acids separate, usually in a finely divided form. When it is desired to obtain red oils containing as large a proportion of oleic acid and as little solid acids as possible, the oil is chilled and the resulting somewhat pasty mass passed through a filter press, such as shown in Figs. 56, 59, the greasy solid fatty acids thus obtained being worked up with fresh batches of the original mixture of acids; for the manufacture of oleine soap this treatment is not indispensable, but inasmuch as the solid fatty acids are considerably more valuable than the fluid ones, it is obviously desirable to obtain as large a proportion of the former as possible. For the same reason it is essential that the saponification of the fats used should be as nearly complete as possible, not only because all the stearic and palmitic glycerides that escape saponification are lost so far as solid fatty acids are concerned (being expressed fluid during the pressing operations), but also because their presence tends to prevent the proper crystallisation of the solid acids, and thus to increase the proportion of these contained in the red oils. In actual practice, it is impossible to carry the decomposition in open pans to absolute completeness without seriously prolonging the operation, which entails extra cost; so that a few per cents. (and sometimes much more, up to 10 or 12 per cent.) of the glycerides used are generally left undecomposed in the rock, ultimately finding their way into the red oils.

When the tallow used has been adulterated by mixing in woolgrease or similar material containing unsaponifiable matters, these substances are generally also ultimately contained in the red oils, thereby diminishing the proportion of "stearine"

obtainable, partly because of the smaller proportion of solid glycerides present in the adulterated tallow, and partly because the presence of woolgrease, like that of unsaponified fat, tends to interfere with the crystallisation of the acids, and hence causes the red oils to retain more solid acids. Moreover, when the red oils are made into soap, a deteriorating effect (for certain purposes) is brought about in the resulting soap; on solution in water and standing, soap containing such unsaponifiable matter is apt to throw up an oily film, rendering the solution liable to spot and grease goods rinsed through the soap solution. Accordingly, it is preferable to buy tallow by analysis, the price varying according to the proportion of solid fatty acids present (estimated by Dalican's process, p. 74, or otherwise) and deductions being made for unsaponifiable constituents. As yet, however, this system does not seem to have been widely adopted in this country.

Composition of "Rock."—The following analyses represent the general composition of open pan "rock" as obtained on the manufacturing scale; A being normal rock made from genuine tallow mixed with about one-fourth its weight of palm oil; and B rock from tallow adulterated with woolgrease containing a considerable amount of cholesterol and other unsaponifiable matters:—

	A	B
Lime present as lime soap (CaO),	7.50	6.27
Lime used in excess (CaO),	1.95	2.41
Fatty anhydrides* present as lime soap,	73.30	61.20
Unsaponified glycerides,	5.55	8.40
Unsaponifiable organic matter,	2.75	12.00
Water and carbonic acid (CO ₂), combined with the excess of lime; sand and grit, &c.; uncombined water (moisture),	8.95	9.72
	100.00	100.00

Since 100 parts of triglycerides of mean molecular weight near 285, represent about 92 parts fatty anhydrides, the fatty anhydrides present in these two samples represent respectively about 80 and 66 parts of original glycerides per 100 of rock; hence the proportion of glycerides originally used which remain unsaponified are (A) $\frac{5.55}{80 + 5.55} \times 100 = 6.5$ per cent., and

(B) $\frac{8.40}{66 + 8.40} \times 100 = 11.3$ per cent.—*i.e.*, in the first case about $\frac{1}{8}$, and in the second about $\frac{1}{5}$, of the original glycerides escaped saponification.

* "Fatty anhydrides" = fatty acids, less an equivalent of water—*e.g.*, in the case of stearic anhydride $\left. \begin{array}{l} \text{C}_{18}\text{H}_{35}\text{O} \\ \text{C}_{18}\text{H}_{35}\text{O} \end{array} \right\} \text{O}$; so that the sum of the fatty anhydrides and the lime combined with them as lime soap, represents the actual amount of lime soap present. In the above two instances the amounts of lime soap are (A) $73.30 + 7.50 = 80.35$; (B) $61.20 + 6.27 = 67.47$.

Analysis of Rock.—This is conveniently effected by taking a known weight of an average sample and boiling it with water to which an excess of standard acid (preferably hydrochloric) has been added, until completely decomposed; on standing, the liberated fatty acids, &c., form a cake on the top, which is carefully removed, dried, and weighed; * the free fatty acids therein are then titrated in alcoholic solution with standard alkali, and the examination for admixed glycerides and unsaponifiable matters proceeded with, as in the case of separation cake (*vide infra*, p. 378). The excess of acid in the watery fluid is back titrated, so as to obtain the acid neutralised by the total lime present, which is thence calculable; whilst the lime present as lime soap (combined with fatty acids) is similarly calculated from the amount of alkali neutralised by the fatty acids. For example, 10 grammes of a given sample of rock were boiled with water and 50 c.c. of normal acid; on back titration 16.7 c.c. were found to be unneutralised; hence 33.3 c.c. were neutralised, equivalent to 0.932 CaO = 9.32 per cent. of total lime. The separated fatty acids, &c., weighed 8.215 grammes, and neutralised 25.9 c.c. of normal alkali, equivalent to 0.725 gramme, or 7.25 per cent. of CaO; whence $0.932 - 0.725 = 0.207$ gramme of excess of lime was present, or 2.07 per cent. On further examination (p. 378) the separated fatty acids were found to contain 0.535 gramme of unsaponified glycerides and 0.235 grammes of unsaponifiable matters. Hence the actual fatty acids present in the 8.215 grammes of cake obtained amount to $8.215 - (0.535 + 0.235) = 7.445$ grammes. In order to reckon the fatty anhydrides equivalent to this amount of fatty acids, 18 parts of water must be subtracted for 56 of CaO combined with them as lime soap—i.e., $\frac{18}{56} \times 0.725 = 0.233$ gramme of water must be subtracted, leaving $7.445 - 0.233 = 7.212$ grammes of fatty anhydrides present as lime soap.

Hence the whole analysis is—

Lime present as lime soap (CaO), . . .	0.725 grammes =	7.25 per cent.
„ in excess,	0.207 „ =	2.07 „
Fatty anhydrides present as lime soap,	7.212 „ =	72.12 „
Unsaponified glycerides,	0.535 „ =	5.35 „
Unsaponifiable matter,	0.235 „ =	2.35 „
Combined water, CO ₂ , sand, moisture, &c. (by difference),	1.086 „ =	10.86 „
	<hr/>	
	10.000	100.00
Total lime soap present, 7.25 + 72.12	=	79.37 per cent.
Total lime present, . 7.25 + 2.07	=	9.32 „

* If the quantity is too small for accurate determination in this way the liberated fatty acids, &c., may be dissolved by ether, and the ethereal solution separated and evaporated, &c., as in the parallel case of soap analysis (Chap. XXI.)

Milly Autoclave Process—Saponification with Alkalies (Lime) under Increased Pressure.—As practically carried out, this process is virtually a combination of the previous process, and that subsequently described due to Tilghmanns, where fats are hydrolysed by the action of water under high pressure. The tallow and palm oil or other fatty mixture is pumped into a stout copper pressure vessel or *autoclave*, and lime made into a thin cream with water added in much smaller proportion than in the open pan process, usually 2 to 3 parts of lime per 100 of fat, or somewhere about one-quarter of the theoretical amount instead of an excess. High pressure steam is then gradually blown in from a boiler until the pressure amounts to at least 7 or 8 atmospheres, and preferably 12 to 15, especially when tallow only is used, as in many Continental factories. After some hours continuance of digestion under pressure the fat is practically completely saponified and hydrolysed, partly by the lime, partly by the action of water only, the presence of the lime soap formed by the saponification greatly facilitating the hydrolysis; the mixed "sweet water," fatty acids, and lime soap are blown off into a tank, where the latter separate from the watery glycerol solution, and are then treated with sulphuric acid precisely as in the open pan process, saving that as much less lime is used, a proportionately smaller quantity of acid is requisite. The further operations of separating solid fatty acids by pressure, &c., are identical in the two processes.

The remarks above made respecting the objectionable results brought about when any considerable amount of glycerides escapes saponification, and when the tallow is adulterated with wool-grease or other unsaponifiable matters, obviously apply equally in the present case. As regards the former point, the following figures were obtained by the author in a set of experiments on a manufacturing scale made with the object of tracing out the effect of increased time in diminishing the amount of unsaponified grease. A series of charges was worked off in the same autoclave, the mixture of fats (tallow and palm oil), and the proportion of lime used, and the pressure being as nearly as possible the same throughout, but the times being different. The fatty acids obtained (after separation from lime by sulphuric acid) were analysed so as to obtain the data for determining the proportion of grease unsaponified during the digestion. The figures ultimately obtained on averaging a number of trials were—

Time in Hours.	Unsaponified Grease Reckoned per 100 parts Originally Employed.
4½	9·4
5½	5·8
7½	3·1

During the first hour or two the rate of decomposition of the fats employed was rapid, from $\frac{3}{8}$ to $\frac{7}{8}$ being converted at the end of 2 hours ; subsequently the action was much slower, becoming practically complete at the end of 6 to 6 $\frac{1}{2}$ hours, not more than about $\frac{1}{10}$ then remaining unconverted.

The following analyses indicate the composition of the "rock" obtained by the autoclave process ; they principally differ from those above cited for open pan rock, in that whereas in the open pan process excess of lime is used, so that the rock contains all the fatty acids as lime soap ; in the autoclave lime process a deficiency of lime is employed, so that the fatty acids are obtained partly as lime soap and partly as free acids :—

	I.	II.	III.
Lime present as lime soap (CaO),	3.20	2.38	2.52
Fatty anhydrides combined therewith,	31.90	22.62	23.94
Free fatty acids,	57.75	58.50	66.30
Unsaponified glycerides,	5.90	6.60	3.20
Unsaponifiable organic matter,	0.70	1.33	1.85
Grit and mineral matters ; water,	0.55	8.57	2.19
	100.00	100.00	100.00

100 parts of the fatty glycerides used originally represent about 95 of free fatty acids and 92 of fatty anhydrides, whence 100 parts of rock represent in these three cases respectively about 95, 86, and 96 parts of fatty glycerides that have been saponified and hydrolysed ; whence the proportions of glycerides not acted upon are—

$$\text{I. } \frac{5.90}{95 + 5.90} \times 100 = 5.8 \text{ per cent.}$$

$$\text{II. } \frac{6.60}{86 + 6.60} \times 100 = 7.1 \text{ ,,}$$

$$\text{III. } \frac{3.20}{96 + 3.20} \times 100 = 3.2 \text{ ,,}$$

In general, with unadulterated tallow, the autoclave process, properly worked, saponifies and hydrolyses about 95 per cent. of the glycerides used, leaving some 5 per cent., or $\frac{1}{20}$, unacted on ; if, however, too low a pressure be applied, the proportion of undecomposed glycerides may amount to considerably more than this unless a proportionately longer time be allowed, involving greater cost for fuel, labour, &c.

The "separation cake" or mixture of fatty acids obtained by decomposing with sulphuric acid the "rock" formed in the

autoclave or open pan process consists of the solid fatty acids produced (chiefly stearic and palmitic); the liquid acids (mainly oleic); and whatever undecomposed glycerides and unsaponifiable organic matters may be present; the latter two ingredients obviously vary with the degree of perfection or imperfection attained in saponification, and with the purity of the materials. The ratio between solid and liquid fatty acids also varies somewhat with the character of the tallow and other fatty matters used; in general, it is not far from 2 to 1. In examining such materials, the author has found the "iodine test" (pp. 177, 179, *et seq.*) particularly useful, especially in the case of press cake in different stages of pressing. The further the pressing (hot after cold) is carried, the smaller the quantity of oleic acid left in the "stearine;" but no amount of hot pressing will completely eliminate "unsaturated" acids,* from 1 to 2 per cent. being retained even when the pressing has been carried to the utmost possible extent permissible for commercial purposes in the preparation of articles of exceptionally high melting points, and larger proportions up to 4 or even 5 per cent. in products less thoroughly hot pressed. Even crystallisation several times from alcohol of a mixture of palmitic and stearic acid does not succeed in removing all the oleic or other iodine-absorbing acid present. Thus the following typical figures may be cited, obtained by the author with the fatty acids manufactured from a mixture of tallow and palm oil:—†

	Percentage of Oleic Acid by Iodine Test.	Melting Point in Capillary Tube.
Separation cake (mixture of fatty acids before pressing),	32·0	...
Cold-pressed cake,	11·5	52°·8 C.
Once hot pressed,	5·6	54°·2
Twice "	2·5	56°·1
Three times hot pressed,	1·3	56°·2
„ twice recrystallised from alcohol,	0·8	56°·25
Red oils (oleine) from cold pressing,	71·5	...
Grease from hot pressing,	14·9	51°·6

The percentage of solid fatty acids contained in red oils can be deduced approximately from the determination of the oleic acid, reckoning 111·02 parts of acid per 100 of iodine consumed, as indicated by the equation—

* Possibly isoleic acid (m.p. 45°), and not oleic acid, remains.

† When a pressed stearine is examined, presumably only containing a small percentage of oleic acid, 5 grammes may be conveniently taken for analysis; on the other hand, with a substance containing a high percentage of oleic acid, proportionally less should be weighed up, usually from 0·2 to 0·4 gramme.

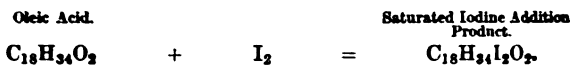

If the percentage of unsaponified grease and unsaponifiable organic matters present be known = a , and that of oleic acid thus determined = b , the percentage of solid fatty acids is approximately $100 - (a + b)$.

Muter's process for the determination of the proportion of oleic acid present in a mixture of that substance with solid fatty acids (stearic and palmitic) is based on the solubility of lead oleate in ether. In the case of a glyceride, a quantity of substance not exceeding 1.5 grammes is saponified with excess of alcoholic potash; with free fatty acids it is dissolved in the same solvent; water is added and the alcohol boiled off; dilute acetic acid is then added to neutralise excess of alkali, until a decided permanent turbidity is produced, and then dilute caustic potash with continuous agitation until the liquid *just clears again*. The clear solution is then precipitated by lead acetate in slight excess, and stirred until the lead soap settles thoroughly; the supernatant liquor is poured off, and the precipitate washed by boiling with a large bulk of distilled water and decanting. Perfectly neutral lead stearate + palmitate + oleate is thus obtained; the precipitate is transferred to a flask of about 100 c.c. capacity and digested for some hours (with frequent agitation) with absolute ether; the ethereal solution of lead oleate is filtered into a stoppered graduated tube holding 250 c.c., and the filtrate and washings decomposed by agitation with about 20 c.c. of a mixture of 1 volume strong hydrochloric acid and 2 volumes water. Finally, a known fraction of the ethereal fluid is drawn off and evaporated to dryness; whence the weight of oleic acid is deduced. The ethereal solution is conveniently drawn off by means of a side tap fixed to the graduated tube about one-fifth of the way up from the bottom, so as to be above the level of the acid watery fluid ("Muter's oleine tube"); or it may be blown off by the washbottle device (p. 120).

De Schepper and Geitel have constructed the table quoted on p. 377, exhibiting the relative proportions of commercial "oleine" (impure oleic acid) of solidifying point $5^{\circ}.4$, and commercial "stearine" (stearic and palmitic acids) of solidifying point 48° present in a sample of separation cake of given solidifying point (compare pp. 75, 76).

The "filter cake" obtained from the red oils when these are chilled and passed through a filter press varies considerably in composition; besides particles of fibre (derived from filter press coverings, &c.) and dust, &c., filtered out, portions of unsaponified grease separate in the solid state from the cooled red oils, and smaller quantities of unsaponifiable matters (cholesterol, &c.) contained in the grease originally used.

Solidifying Point of Separation Cake.	Percentage of Commercial	
	Stearic Acid.	Oleic Acid.
Degrees C. 5·4	0	100
10	2·5	97·5
15	6·6	93·4
20	12·1	87·9
25	18·5	81·5
30	27·2	72·8
32	31·5	68·5
34	36·6	63·4
36	43·0	57·0
37	46·9	53·1
38	50·5	49·5
39	54·5	45·5
40	58·9	41·1
41	63·3	36·7
42	68·5	31·5
43	73·5	26·5
44	78·9	21·1
45	83·5	16·5
46	89·0	11·0
47	94·1	5·9
48	100·0	0

The following analyses represent its usual composition :—

Free fatty acids, solid,	54·2	...	51·4
" " liquid (oleic acid),	25·0	...	21·5
Unsaponified glycerides,	11·2	...	12·3
Unsaponifiable organic matters,	4·3	...	4·9
Fibres, dust, &c.,	5·3	...	9·3
	<u>100·0</u>		<u>100·0</u>

Since the great majority of the unsaponified glycerides contained in the rock find their way into the red oils, whilst these latter constitute the smaller half of the fatty acids obtained (the "stearine" amounting to upwards of 50 per cent. of the total acids) it results that the percentage of unsaponified glycerides present in the red oils is usually more than double that in the separation cake. The same remark applies to the unsaponifiable organic matters. If the red oils be distilled by means of superheated steam the unsaponified glycerides present mostly become hydrolysed during the operation, so that "distilled oleine" is practically free from glycerides. On the other hand, a small proportion of the oleic acid becomes decomposed during the process, forming hydrocarbons (compare p. 278), so that the unsaponifiable organic matters usually become notably increased in amount. The following analyses indicate the composition of

different samples of red oils and "distilled oleines," and illustrate these points:—

	Red Oils.		Distilled Oleines.	
	Tallow and Palm Oil.	Tallow only.		
Free fatty acids,	86.5	87.85	90.0	89.65
Unsaponified glycerides,	11.7	11.30	1.6	2.95
Unsaponifiable organic matters, hydrocarbons, &c.,	1.8	0.85	8.4	7.40
	100.0	100.00	100.0	100.00

Analysis of Red Oils, Separation Cake, and Similar Products.—This is carried out substantially in the way indicated on p. 162. The "free acid number," A, being determined, and also the "total acid number," K, the data are obtained for calculating the percentage of free fatty acids and unsaponified glycerides present if the mean molecular weight of the fatty acids is known or assumed. The unsaponifiable organic matters being determined (by the methods described on p. 119) and the percentage of these constituents subtracted from 100 (as also that of any water or other foreign substance accidentally present), a sufficiently close approximation to the truth is obtained by

multiplying the difference, D, by $\frac{A}{A + (K - A) \times 1.05}$ for the per-

centage of free fatty acids, and by $\frac{(K - A) \times 1.05}{A + (K - A) \times 1.05}$ for that

of the undecomposed glycerides; for if E be the mean equivalent of the fatty acids, E + 12.67 is that of the glycerides (p. 165); and as E usually lies between 255 and 285, the ratio of E to E + 12.67 will lie between 1 to 1.050 and 1 to 1.045, and may safely be taken as 1 to 1.05; so that the weights of free fatty acids and glycerides will be substantially in the ratio of A to $(K - A) \times 1.05$, whence the percentages will be—

$$\text{Free fatty acids} = \frac{A}{A + (K - A) \times 1.05} \cdot D$$

$$\text{Glycerides} = \frac{(K - A) \times 1.05}{A + (K - A) \times 1.05} \cdot D$$

Thus supposing that a given substance contains 5 per cent. of unsaponifiable matter, &c., and consequently that D = 95; if the free acid number, A, be found = 175.0 and the total acid number, K, = 195.0, so that K - A = 20, the composition will be—

Free fatty acids	$\frac{175}{175 + 20 \times 1.05}$	=	$\frac{175}{196}$	=	89.28
Glycerides	$\frac{20 \times 1.05}{175 + 20 \times 1.05}$	=	$\frac{21}{196}$	=	10.72
Unsaponifiable matters, &c.,				=	5.00
					<u>100.00</u>

From these figures it results that the value of E is close to 286; for 1,000 parts of substance contain 892.8 of free fatty acids neutralising 175.0 of KOH; whence

$$175.0 : 56.1 :: 892.8 : x = 286.2$$

Similarly the mean equivalent of the glycerides is close to $286.2 + 12.67$, or nearly 299.

Several attempts have been made to substitute metallic oxides for lime in the autoclave lime process, more especially magnesia and zinc oxide. At ordinary pressure these bodies usually act upon fatty glycerides (such as tallow) appreciably more slowly than lime, probably on account of their greater insolubility in water; but it is claimed that under pressure this difference is not observed, but rather the contrary, so that a much smaller proportion of zinc oxide will effect the saponification and hydrolysis of fatty matter than is necessary in the case of lime: thus in the British patent specification of Poullain, E. F. Michaud, and E. N. Michaud (No. 5,112, 1882) from 2 to 5 parts of zinc oxide are directed to be used per 1,000 of fatty matter (0.2 to 0.5 per cent.), heat being continued for 3 to 4 hours under a pressure of 100 to 130 lbs. (7 to 9 atmospheres). It is claimed that the smaller proportion of base employed renders it necessary to use much less acid to obtain pure free fatty acids than would otherwise be required; whilst for certain purposes—*e.g.*, manufacture of scouring soaps—it is not necessary to dissolve out the zinc at all. As regards magnesia, comparative experiments with lime and magnesia show that the action of the latter is always inferior to that of the former (*vide Journ. Soc. Chem. Industry*, 1893, p. 163).

A somewhat analogous process has been proposed, where ammonia is used as saponifying agent, fatty matters and aqueous ammonia being heated together under pressure. Ammonia soaps, if formed, are so far wanting in permanency that by blowing steam through them they are decomposed, ammonia passing off (collected for use over again), whilst free fatty acids and glycerol solution remain. It does not appear that this system has as yet been adopted so largely as to rank as an established practical manufacture; but if sufficiently complete decomposition is obtainable in a moderate time, *a priori* the method would seem to be of a workable character.

Stein, Bergé, and de Roubaix have patented* the use of solution of sulphurous acid or alkaline bisulphite as hydrolytic agent; from $2\frac{1}{2}$ to 3 per cent. of solution is added to the fat in a pressure vessel, and the temperature raised to 170° to 180° , whereby a pressure of some 18 atmospheres is attained; the reaction is said to be complete in about 9 hours. The temperature should not exceed 200° C.

Hydrolysis of Fats by means of Sulphuric Acid.—It has long been known that free fatty acids are obtainable from glycerides by acting upon them with sulphuric acid, the glycerol being largely converted into glycerosulphuric acid (p. 144), subsequently more or less decomposed by the heat, and the fatty acids being to some extent similarly acted upon, especially in the case of oleic acid. The "Wilson" process (sometimes called the "Dubrunfaut" process), the outcome of various methods originally patented in England by Gwynne, Jones, and Wilson (Price & Co.) in 1840 to 1843, substantially depends on these reactions, with the further addition of purification of the fatty acids by distillation with superheated steam; the melted fats (more especially palm oil) are heated in a stout copper vessel (the "acidifier") to about 300° to 350° F = 149° to 177° C., by means of superheated steam; sulphuric acid is then run in to the extent of 3 to 5 per cent., the whole intermixed, and allowed to stand some hours; during this period the glycerides are broken up, and foreign organic matters present mostly carbonised. In general, the less the quantity of sulphuric acid used, the higher is the temperature employed. The acid mixture is then run off and boiled up with water by means of wet steam, so as to wash out sulphuric acid and other products soluble in water; after standing for some hours to settle, the crude fatty acids are separated and heated to about 240° F. (116° C.) to complete the removal of water; finally superheated steam at a higher temperature is passed through, the precise temperature varying with the nature of the fatty matter used, but being usually near 560° F. (294° C.)

Under these conditions the fatty acids are volatilised, and are condensed along with most of the steam in a series of copper serpentine refrigerating pipes exposed to the air, the escaping vapours being deodorised as far as possible by a water shower to absorb acrolein, &c., and subsequently burned, much as in the somewhat analogous case of rendering animal fats (p. 247). The fatty acids thus obtained contain a much larger proportion of solid acids, and less fluid oleic acid than those obtained by the lime saponification process from the same material, whether by the open pan or autoclave method; it would seem very probable that this is due to the transformation by the action of sulphuric acid of oleic acid into isoleic acid (melting at near 45° C.), as in the case of the action of zinc chloride on oleic acid (p. 142); or,

* German patent, No. 61,329.

possibly, stearylactone or oxystearic acid is formed. According to Lant Carpenter,* tallow which will only yield about 50 per cent. of its weight of candle material when treated by the lime process, gives by the sulphuric acid process at least 75 per cent. of such material of but slightly inferior quality. Of this, about three-fourths is ready for candlemaking without further treatment; the other fourth, when pressed and redistilled, yields some 75 per cent. of its weight of stearic acid, and 25 of oleic acid; ultimately, only about 5 parts of oleic acid per 100 of fat are obtained.

A considerable proportion of black pitch (often amounting to 15 per cent. and upwards) is obtained as bye product, whilst the glycerol obtainable from the acid liquors, &c., is much less in quantity and more costly to isolate than that from the lime process; accordingly, whilst the larger yield of solid fatty acids renders the acid method more economical from one point of view, it must be taken into consideration, *per contra*, that pitch instead of oleine is obtained as part of the product,† and that glycerol

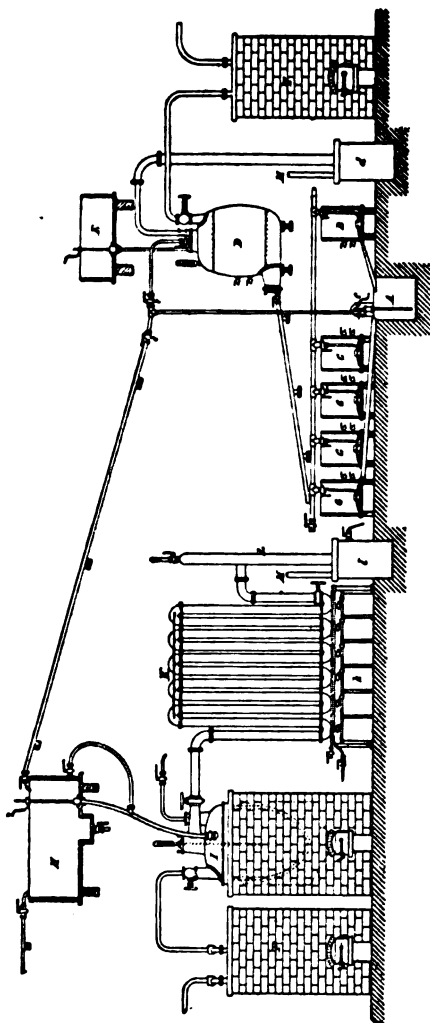

Fig. 83.

* Spon's *Encyclopædia*, p. 581, *et seq.*

† By distillation at a higher temperature the pitch left on the first distillation affords a certain proportion of fatty acids of inferior quality.

is lost, thus materially diminishing the apparent advantages.

Fig. 83 illustrates the general character of the plant used in the process.* A is the tank into which the tallow, &c., is melted by means of a steam jet directed upwards into the bung-hole of the cask. B, one of a series of leadlined tanks, in which the grease is heated before treatment with sulphuric acid, so as to boil off water. C, pump with suitable taps and connections enabling it to pump up the hot grease into the "acidifier," D; or into the tank, H, supplying the still, I, after the sulphuric acid has been washed out with water. E, acid tank supplying acidifier. F F, superheaters. G G G G, washing vats, where the acidified grease is boiled up with water and steam to wash out sulphuric acid, &c. H, grease tank supplying still, I, through which superheated steam is blown, the vapours being condensed by the refrigerator, K, and copper cooling coils contained in the tanks, k. L, scrubber to condense acrolein, &c. M, pipe leading uncondensed vapours, &c., away to combustion flue for destruction.

Fig. 84 represents Knab's apparatus for continuous distillation

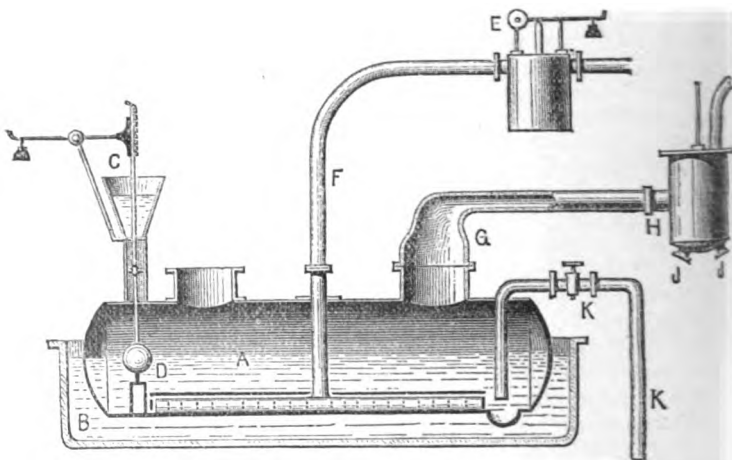

Fig. 84.

by superheated steam. A is the distillation vessel, into which the fatty acids to be distilled are run through the supply funnel, C, at intervals regulated by the rising and falling of the float valve, D. Superheated steam enters by the pipe, F (furnished with regulating valve and safety valve, E), and passes in small streams through the molten fatty acids from the horizontal coil

* L. Field, "Cantor Lectures," 1883 (*Journ. Soc. Arts*, vol. xxxi, p. 861).

at the base. The vapours pass off through the neck, G, to the condenser; the most easily condensed fatty acids are collected in H, and drawn off from time to time through the cocks, J J, whilst the other vapours pass on. K K is a blow off pipe for removing residual pitch at intervals, the supply of fatty acids through C being temporarily shut off. Heat is applied by means of a bath of molten lead or other suitable metal contained in the outer pan, B.

According to Schädler, the quantities of steam requisite for distillation of a given quantity of fatty acids at different temperatures are as follows:—

Temperature.	Weight of Steam for 1 part of Fatty Acids.
200° to 230°	7 parts.
230° to 260°	3 to 4 parts.
290°	2 parts.
325° to 356°	1 part.

When the distillation temperature does not exceed 240°, the distilled fatty acids are almost white; at 260° a little coloration is manifest; at 290° this is more marked, whilst at temperatures above 300° the distillate is yellow or brown.

Numerous other forms of apparatus for effecting distillation by means of superheated steam have been constructed for particular purposes—*e.g.*, the purification of grease from cotton seed foots (p. 261), of Yorkshire grease (p. 277), and similar substances; for the most part these differ from the above arrangements more in details of construction than in general principles.

In Marix' arrangement for the distillation of free fatty acids produced by hydrolysis or otherwise an air pump is applied, so that a temperature of 250°-255° suffices for the distillation under diminished pressure. A similar process has been patented by Lewkowitsch (English patent, 5,985, 1888), the pressure being reduced by 10 to 13 lbs., so that a temperature of about 460° F. (238° C.) suffices, instead of about 600° F. (316° C.)

It is noticeable that when the products of distillation of a charge of given material are collected in separate fractions, it is found that in some cases the portions first passing over are the most fusible, those coming over later possessing successively higher and higher melting points; whilst with other fatty matters the reverse is the case. Thus, with palm oil the first distillate is sufficiently solid to be used for candlemaking without any further treatment, whilst the later portions are softer, and must be pressed before they can be thus employed. With bone fat, on the other hand, the successive fractions show a regular increment in consistency. The following illustrative figures are given by

Payne as the melting points of the fatty acids collected in seven different fractions:—

Fraction.	Bone Fat.	Palm Oil.
	Degrees C.	Degrees C.
1	40	54·5
2	41	52
3	41	48
4	42	46
5	45	44
6	45	41
7	47	39·5

In almost all cases, however, the average melting point of the distilled fatty acids exceeds that of the crude acids before distillation.

Bock's Process.—In Wilson's process the hydrolysis of the glycerides is mainly effected under the influence of comparatively concentrated sulphuric acid at a tolerably high temperature (150° to 180° C.), and subsequently completed partly by adding water and boiling up with wet steam, and partly by distillation with superheated steam; Bock's process differs therefrom in that the hydrolysis is mainly effected by comparatively dilute sulphuric acid, the action of which is facilitated by the removal of the nitrogeneous films or envelopes coating the fatty globules by means of concentrated sulphuric acid acting at a much lower temperature than in Wilson's process. Tallow, &c., is heated to 115° in an open vat* and well agitated with from 4 to 6 per cent. of sulphuric acid, whereby the albuminous envelopes are charred and broken up, but little or no hydrolysis effected. Water is then added, and the blackened but still neutral fat boiled up with the resulting dilute sulphuric acid for some hours until the decomposition of the glycerides is complete, the degree being judged by the mode of crystallisation of the fatty acids on cooling a sample. When complete, the acid fluid is run off and neutralised with lime, and the resulting aqueous crude glycerine solution concentrated for sale. The blackened fatty acids are then subjected to oxidation by means of bichromate or permanganate of potash and sulphuric or hydrochloric acid, or of nitric acid, bleaching powder, &c., whereby the albuminous charred matters are largely increased in density so that they subside, leaving the fatty acids of a pale brown tint; these are then washed and crystallised, and subjected to cold and hot pressure in the usual way, whereby a brown oil and a white stearine are obtained. The solid acids obtained are said to be whiter, of higher melting point, and larger in quantity than those obtained from the same

* Lant Carpenter, *British Association Reports*, 1872, p. 72; vide also *Dingler's Polytech. Journ.*, May, 1873.

material by lime saponification, probably through formation of isoleic acid, stearylactone, or oxystearic acid, &c. (pp. 29, 39); whilst 6 to 7 per cent. of glycerine solution at 38° F. (specific gravity 1.19, containing about 70 per cent. of actual glycerol) is obtainable. The plant is simple, all the operations being carried out in one vessel; and as only open steam is used there is no danger of explosion as with autoclave processes. If desired, the brown oleic acid can be distilled by means of superheated steam; or it can be converted into palmitic acid by Radisson's process (*infra*), for which purpose it is well fitted. 100 parts tallow yield 95 of crude fatty acids, reduced to 93 by oxidation and washing, of which 55 to 60 parts are obtainable as candle stearine, melting at 58° to 60° C. (136° to 140° F.)

Hydrolysis of Glycerides by Water Only.—In 1854 a patent was taken out by Tilghmann for the decomposition of glycerides by means of water under great pressure, and correspondingly high temperature; in one form of apparatus a mixture of fat and water was forced through a coil heated to about 420° C. (upwards of 800° F.), the pressure approximating to a ton per square inch (some 140 atmospheres). Various improvements were subsequently made; but the practical difficulties attending the working of manufacturing operations of the kind prevented the method being largely adopted. A modification of the process, patented shortly afterwards by Wilson & Payne (No. 1,624, 1854), effects the same result in a much simpler way. The fatty matter being heated in a still to about 300° C., steam from a superheater is blown through it by means of a rose jet or false bottom perforated with a large number of small holes, so that numerous jets of steam rise through the mass. Hydrolysis takes place, and the fatty acids and glycerol formed are volatilised and carried over with the excess of steam to the condensers, where the free fatty acids and glycerol in aqueous solution are obtained; the former condense first, so that by using a series of condensing chambers, little but fatty acids are obtained in the earlier ones, whilst chiefly watery glycerol condenses in the later ones, yielding a very pure commercial glycerine by simple concentration after separating the small quantity of accompanying fatty acids. Fig. 85 represents the general character of this plant. Steam is superheated in the superheater A, and passes into the retort, C, covered in with a lid, E; the vapours pass off to the condensers, G, for fatty acids, and F for glycerol water. If the temperature is too high (above 315°), much loss of glycerol occurs through the formation of acrolein.

In France, the saponification of fatty matters by means of water alone (without lime, &c.) is much more largely carried out than in Britain, on account of the more frequent use of pure "stearine" candles, instead of those made largely or wholly of paraffin wax. Several different forms of apparatus are in use: for

a description of some of these exhibited at the Paris Exhibition, *vide* B. Lach, *Chem. Zeit.*, 13, pp. 1157, 1218, 1335, 1374; in abstract *Journal Soc. Chem. Ind.*, 1890, p. 82.

Utilisation of Red Oils.—In the manufacture of candle material from glycerides a more or less considerable proportion of “red oils” is obtained, the amount varying with the

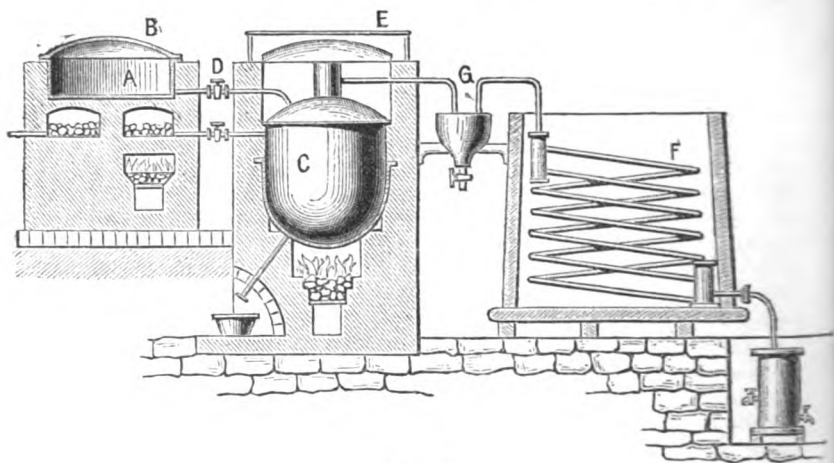

Fig. 85.

method of saponification or hydrolysis adopted, the nature of the fatty matters used, and the temperature at which the cold pressing is effected. Commercially, the “oleine” thus produced is considerably less valuable than the solid “stearine;” whence, *ceteris paribus*, it is desirable so to conduct the operations as to obtain the maximum yield of solid products and the minimum of liquid ones. In general the red oils thus produced are utilised by conversion into so-called “oil soap,” by direct saturation with soda ley of appropriate strength (*vide* Chap. xx.); but various attempts to employ them as a source of other more valuable products have been made. One such process, due to v. Schmidt, consists in heating the red oils with about 10 per cent. of zinc chloride to a temperature of about 185°; whereby conversion into more solid substances is brought about, chiefly by formation of isoleic acid and stearylactone (*vide* p. 142). Another process (Radisson’s, *vide infra*) depends on the conversion of oleic into palmitic acid by fusion with alkalies; whilst Zürer has attempted* to convert oleic into stearic acid by first subjecting to the action of chlorine, and then treating the dichloride of oleic acid formed

* German Patent, No. 62,407.

with nascent hydrogen evolved from zinc dust (or finely divided iron or magnesium) and water heated under pressure.*

Radisson's Artificial Palmitic Acid.—It has long been known that acids of the oleic family when fused with caustic potash undergo a peculiar decomposition evolving hydrogen, and breaking up so as to form two acids of the stearic family, of which acetic acid is generally, if not invariably, one (p. 24); e.g., oleic acid when thus treated breaks up, forming *palmitic acid* in accordance with the equation—



M. St. Cyr Radisson has succeeded in carrying out this reaction on a manufacturing scale, converting some 3 tons oleic acid into palmitic acid per diem. The fusion is effected in a covered iron cylindrical pan or "*cartouche*" with dished base, provided with a mechanical agitator, and set in brickwork some distance (nearly 6 feet) above the firebars of a grate, so that a large hot air chamber is formed underneath, enabling the temperature to be more easily regulated. 1,650 lbs. of oleic acid and 2,750 of caustic potash ley, specific gravity 1.4, are run in; when steam ceases to be evolved, a manhole in the cover is closed, and the evolved hydrogen passes off by a pipe to a purifier and gasholder for other use. The temperature requires to be very nicely adjusted, 300° to 310° being the proper value, whilst at 320° destructive distillation commences; to avoid overheating a Gifford steam injector is provided whereby the temperature of the interior can be reduced when requisite. Some 36 to 40 hours are required for completely working off a charge, including filling the pan and emptying; the progress of the operation is judged by sampling and testing the solidifying point of the acids liberated from the mass by a mineral acid, preferably by Dalican's method (p. 74). When complete, the contents of the pan are run off through an outlet pipe into a tank containing a small quantity of water, and the whole heated up by a steam jet. The excess of potash present then dissolves, forming a strong ley (specific gravity about 1.14) in which the potassium palmitate is insoluble, floating up as a soap; this is transferred to a decomposing vessel where the palmitic acid is set free by means of sulphuric acid; the acid is then distilled in the usual apparatus, leaving some 3 per cent. of pitch, and furnishing a perfectly white acid, melting at 50° to 53° C., burning with a clear smokeless flame. About 87 per cent. of white palmitic acid is obtainable

* De Wilde and Reyckler had previously shown that by heating oleic acid with a small quantity of iodine or bromine under pressure, some 70 per cent. becomes converted into stearic acid (*Bulletin Soc. Chem.*, Paris, 1889, 1, p. 295).

in practice, the theoretical yield being 91 per cent. of the oleic acid used. According to Lant Carpenter, the oleic acid produced by Bock's process (*supra*) is better adapted to the purpose than ordinary red oils prepared by alkaline saponification, a higher yield of palmitic acid being thereby obtained. For further details, *vide* Spon's *Encyclopædia of Arts and Manufactures*, p. 584.

CHAPTER XVII.

MANUFACTURE OF CANDLES, TAPERS, AND NIGHTLIGHTS.

SEVERAL different kinds of process are or have been employed in the manufacture of candles for the purpose of surrounding the wick with a more or less uniform coating of solid combustible matter. In the early and middle ages, when wax was the material used by the more wealthy classes as illuminant, a simple mechanical process of hand manufacture was usually

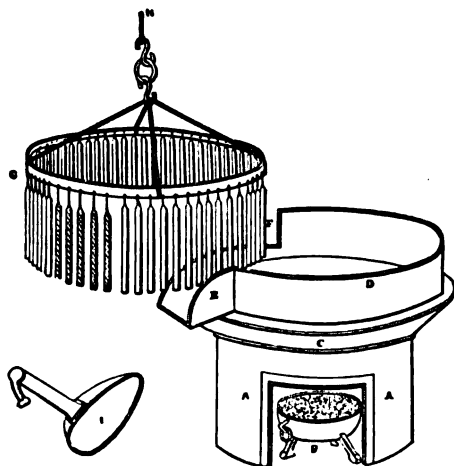

Fig. 86.

adopted, a lump of wax being softened by heat and kneaded until sufficiently plastic, then applied round the wick, and rolled into shape. A similar process is still employed, with the difference that the wax is applied by "pouring" the just melted material over the wick so as to incrust it with a layer of wax; after cooling, another layer is similarly poured over, and so on, the candle being reversed in position from time to

time until the requisite thickness is attained; the still somewhat plastic wax candles are then rolled into shape, some half dozen at a time, on a smooth marble table with a board on which the workman presses heavily; the finished candle consequently exhibits concentric layers of wax, something like the rings of a

tree. The process requires considerable skill to produce a perfectly even surface with truly central wick, especially in the case of large sized candles; to facilitate the "pouring" or "basting" operation, the wicks are usually hung on a horizontal wheel (Fig. 86) fixed over the projecting lip of a large basin holding the melted wax, so that each is "basted" in turn. Large conical altar candles (*cierges*) are still generally made substantially by the older process, the plastic wax being rolled into a long thin strip or ribbon, which is then coiled round the wick (previously soaked in melted wax) and rolled into shape on the marble slab, instead of being basted on.

In practice it is difficult to "mould" wax candles satisfactorily on account of sticking to the mould and shrinkage during solidification, and consequent tendency to crack; but thin candles can

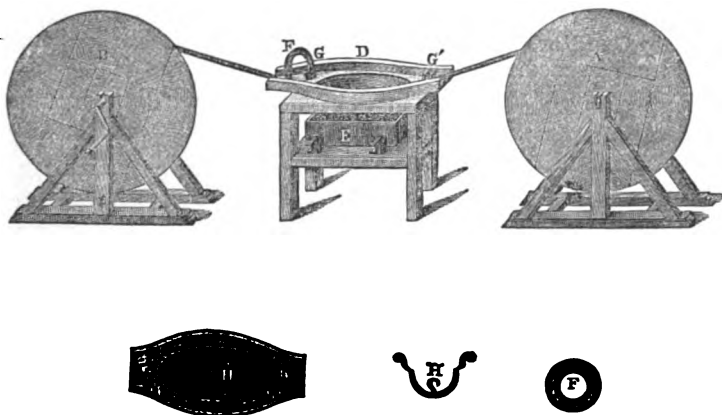

Fig. 87.

be "drawn" somewhat after the fashion of wire by running the wick through a pan of melted wax, and subsequently making it pass through a drawplate so as to reduce the layer of wax to uniform thickness (Fig. 87). The wick is usually wound from one drum on to another; after one coating is applied it is wound back again, this time passing through a somewhat wider draw-hole, so as to give an increased thickness of wax; as a rule, however, neat tapers of more than about half an inch diameter cannot be conveniently made thus, as the tendency to crack becomes too great when the diameter increases beyond this point. In whatever way the wick is coated, whether by "rolling," "pouring," or "drawing," the candles are ultimately finished by cutting off the butt ends clean with a sharp knife (Fig. 88), and trimming the other ends to conical tips. When tinted wax candles are requisite usually only the last batches basted on are

coloured, as the tinting materials are generally apt to clog the wick, especially if solid; for white candles airbleached wax (p. 268) is employed, wax blanched by chemicals (especially chlorine) being unsuitable (p. 267).

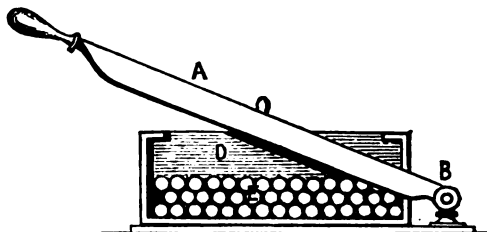

Fig. 88.

Dip Candles.—In the preparation of rough candles for household use in mediæval times and even still more recently,* the wicks used were generally rushes (*Juncus conglomeratus*) skilfully

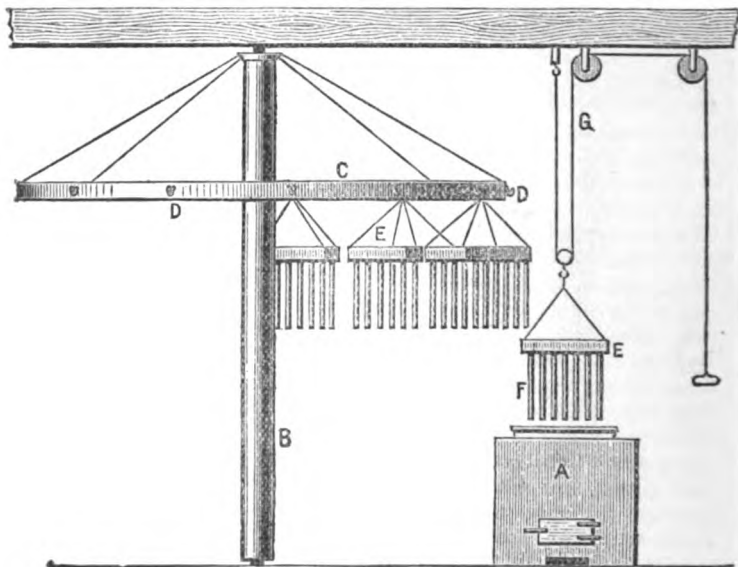

Fig. 89.

peeled so as to leave the pith supported by one thin rib of green rind, whence the familiar term "rushlight." These were soaked (after drying) in melted tallow or kitchen grease, held up to

* Gilbert White, "Natural History of Selborne," 1789.

cool, and then dipped again carefully into the just melted grease and quickly withdrawn, so that the film of adherent tallow solidified before it had time to run down; for which purpose it was imperative that the grease should not be overheated. The dipping was then repeated at intervals until the coating of tallow was sufficiently thick. By and by when tallow candle-making became a trade of itself this method of manipulation was adopted on a larger scale with appropriate modifications; linen or cotton wicks supplanted rush pith, whilst the dipping was effected by fixing a number of wicks (previously soaked in tallow) on hooks driven side by side a little way apart into the bottom of a piece of board or wooden lattice frame, so that by lifting the board by means of a knob or handle on the upper side, all the wicks attached could be simultaneously dipped and withdrawn. To facilitate the dipping, the board with dependent candles was attached to a rope passing over a pulley (Fig. 89); each frame of candles when dipped being unhooked from the rope and suspended from the periphery of a horizontal wheel so as to hang up and harden; by dipping in regular succession each one of a number of frames thus suspended, each batch of candles became sufficiently cooled and "set" to be ready for another dip by the time its turn came; the wheel thus slowly revolved, making one revolution for each dipping of the whole series of frames suspended therefrom. By attaching suitable weights to the end of the cord as counterpoise the time is easily ascertained when the candles have been dipped sufficiently often to be of the right weight.

To avoid the trouble of unhooking each frame and hanging it up from the wheel a series of separate radiating bars have been substituted for the complete wheel, each bar being capable of oscillating in a vertical plane working on a pin in a slot in the vertical axis. Fig. 90 represents a form of "Edinburgh wheel" of this description; each bar, B B, carries two dipping frames, one at each end, the second serving as counterpoise to the first; each frame is successively pulled down and dipped in the tallow cauldron and then raised again, the wheel being made to revolve partially so as to bring the next succeeding frame over the cauldron. Various

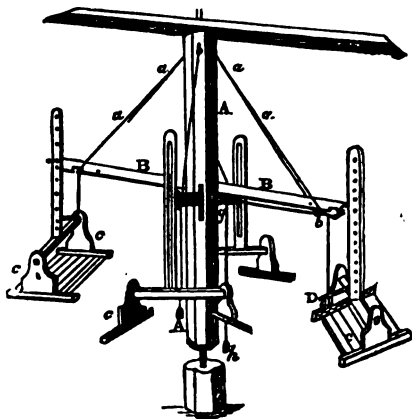

Fig. 90.

subsidiary arrangements are sometimes applied for the purpose of ensuring horizontality of the radiating bars when raised after dipping even though the newly dipped end may be a little heavier than its counterpoise.

The wicks may be suspended from the hooks by means of a loop of cotton thread tied to them; but a more convenient plan is to double the wick, stringing the series over a rod as indicated in Fig. 91. The rod with the dependent wicks is then dipped by hand into a trough of melted tallow and hung up on a rack or otherwise supported until the tallow is sufficiently set to permit of another dipping; or a series of rods are attached side by side to a frame supported by cords and attached to an Edinburgh wheel, &c. In order to impregnate the wicks with tallow in the first instance and to get them all of the right length, the wick is

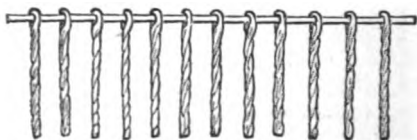

Fig. 91.

unwound from a bobbin, and wound round a square frame of suitable size so as to form a sort of loose covering; this is then dipped bodily in hot tallow to within an inch or so of the top of the frame, so as to fill up all the pores in the immersed portion of the wicking: the entire row of strands at the bottom of the frame is then cut through with a knife, and the different doubled wicks separated, and strung on the rods as indicated.

Another mode of proceeding, formerly much used in the larger dipping establishments, is to have the cauldron of melted tallow movable, so as to pass in succession beneath each one of a series of frames. Fig. 92 represents the section of an arrangement of the kind: the two frames, D D, are connected by a cord passing over pulleys supported by a beam and posts, so that one counterpoises the other; by pulling the cords, E E, the one or the other can be made to descend. A number of these pairs of frames are arranged side by side (Fig. 93) the cauldron of tallow (kept fluid by means of a brazier) running on a railway down one side of the row and up the other, so that each one of the frames is dipped in regular rotation. A sort of mechanical wiper is conveniently connected with the cauldron, so that by moving a lever after the candles have emerged from the molten tallow the drops of melted grease that run down to the bottoms are removed. When well-shaped candles are required, the irregularities may be smoothed down by pulling each candle in succession by hand through a series of holes in a drawplate (graded in diameter, the smallest

being the size ultimately required) so as to strip off a portion of the outer coating, leaving the remainder fairly cylindrical.

A peculiar modification of the dipping process is sometimes practised: the wicks are dipped in hot melted tallow as usual to fill up pores; instead of applying the outer coatings by successive dippings of the treated wicks, thin steel rods are dipped in the tallow; when the candles are of the requisite thickness they are cooled completely, and the steel cores extracted; the wicks are then passed through instead, and fastened in position by a few

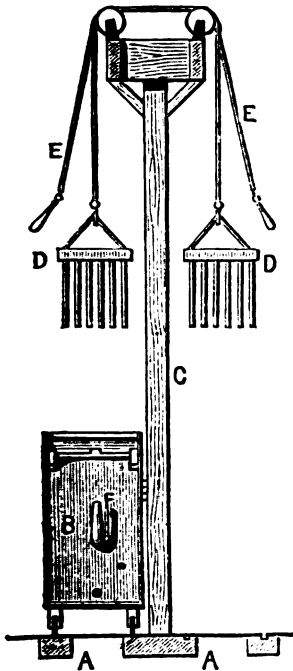

Fig. 92.

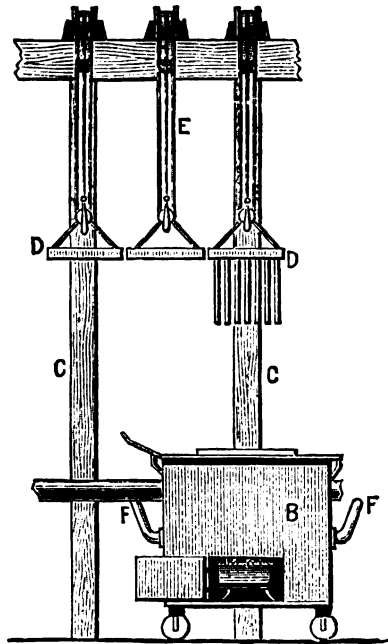

Fig. 93.

drops of melted tallow. A similar device is also employed in the manufacture of certain kinds of night lights (*infra*), except that the wickless hollow candles are made by casting instead of dipping.

At the present day, although the manufacture of dip candles made of unsaponified tallow is by no means extinct (there being still some considerable demand, especially in country districts), the quantity manufactured is much less than that of "moulded" candles, mostly prepared from solid fatty acids (so-called "stearine") and paraffin wax, but sometimes from unsaponified

tallow or mixtures containing both free fatty acids and solid unaponified glycerides (composites). Tallow candles, when blown out, generally emit an acrid vapour, due to the decomposition of the glyceride by the heat of the smouldering wick, with formation of acrolein; this circumstance, together with their comparative softness inducing "guttering," the necessity for "snuffing," and the tendency to emit smoke and give a less clear brilliant light than stearine and paraffin candles, has caused them gradually to fall comparatively into disuse, especially amongst dwellers in towns.

Wicks.—The nature of the wick employed in a candle very greatly affects the way in which it burns, and consequently the light emitted. In the old fashioned tallow dip candle, thick twisted cotton wicks are still used; these do not thoroughly consume away, and consequently "snuffers" are requisite in order to remove the charred smouldering cotton, otherwise much less light is given out, and a smoky flame produced. By various mechanical devices, attempts have been made to give to such twisted wicks a tendency to bend outwards in the flame, so as to come in contact with the air and consume spontaneously; others have sought to attain the same end by incorporating a thin wire with the cotton strands. Palmer's "metallic wick" was an analogous device, where a thread impregnated with powdered bismuth was bound up with a number of others of ordinary fibres by winding one round the bunch; when burnt, the bismuth formed a minute globule at the end of the wick, the weight of which tended to draw the wick outwards; so that the carbonised cotton was burnt away, and the bismuth volatilised, or was otherwise dissipated by combustion. De Milly attempted to gain the same result by impregnating the wicks with boracic and phosphoric acids, &c., so as to form a globule of fused mineral matter. All such devices, however, have been superseded for the better classes of candle by the use of flat plaited or "braided" wicks (first introduced by Cambacères), where the mode of construction imparts a natural tendency to bend outwards. The precise mode of plaiting adopted considerably modifies the way in which the wick burns, one kind of braiding being better suited than another for certain kinds of combustible matter; thus, paraffin candles require a wick more tightly braided than is requisite for stearine candles, whilst looser wicks are used for wax and sperm candles. As a rule, the plaiting of the wicks is not carried out in the candle factory, but by spinners making a speciality of this particular line, and delivering the braids in hanks of convenient size; the machines used much resemble those employed in the manufacture of ordinary braids.

Wick Pickling.—Before conversion into candles, the wicks are soaked or "pickled" in a suitable saline solution for some

hours; they are then drained and finally wrung out by means of a rapidly rotating centrifugal machine so as expel almost the whole of the fluid without twisting the threads in any way, and finally hung up to dry in a room heated by steam pipes. The object of the pickling is, on the one hand, to counteract the accumulation of mineral matter or "ash" in the wick as it burns, and on the other, to prevent the too rapid burning away of the wick fibres before the due quantity of melted fatty matter has passed along them and been consumed in the flame. The choice of the particular solutions employed and their strengths is usually regarded as a trade secret, each manufacturer having his own views on the subject to which experience has guided him; solutions varying from 1 to 5 per cent. of saline matter in strength have been recommended, such as borax (alone, or acidulated with a minute quantity of sulphuric acid), salammoniac, saltpetre, phosphate of ammonium, or mixtures of such salts; although only very minute quantities of saline matters ultimately remain in the dried wicks, yet the effect thereby produced on the way in which the candle burns is often very marked.

MOULDED CANDLES.

The art of moulding candles, instead of dipping them, is due to the *Sieur de Brez* in the fifteenth century; but excepting for the employment of this method in the manufacture of spermaceti candles in the latter part of the last century, but little advance was made in this direction until the introduction of "stearine" (solid free fatty acids) as candle material instead of tallow, and the subsequent employment of paraffin wax for the same purposes a little after the middle of the present century. The earlier moulding machines were so-called "hand frames" (still in use for small operations and special sizes for which only a small demand exists) containing a series of pewter moulds with removable mouthpieces, Fig. 94, depending downwards from a shallow trough, Fig. 95, the top end being lowest and the butt end uppermost. By means of a wire with a hook at the end the wick was hooked through a narrow orifice at the conical lowest end of the mould and brought upwards, and finally fixed to a wire hook, *n*, by means of a knot on the wick, or preferably a little loop of cotton thread tied to the wick; so that by gently pulling the wick downwards at the bottom and fixing it with a peg, it was stretched in the axis of the cylindrical mould (Fig. 96); or instead of a removable mouthpiece carrying a hook like *n*, a short piece of wire was passed through the loop and allowed to rest in a couple of shallow notches opposite to one another in the upper rim of the mould, so that the wick depended axially therefrom. Figs. 97 and 98 represent an improved modification of this arrangement, where, instead of having a



Fig. 94.

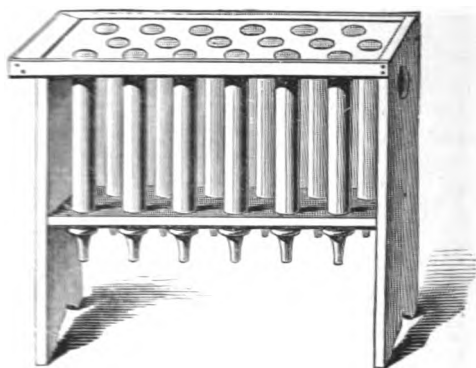

Fig. 95.



Fig. 96.

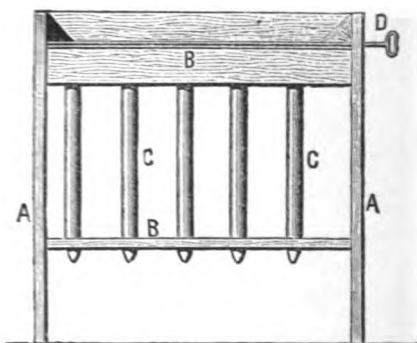

Fig. 97.

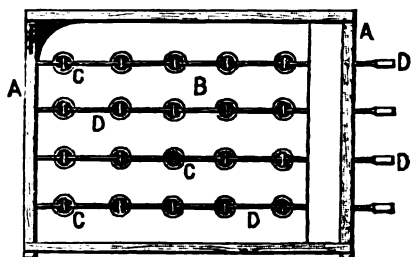

Fig. 98.

separate wire for each candle, a whole row of wicks is simultaneously supported by a single rod, D D, which is withdrawn when the candles are extricated from the moulds after cooling. The use of this rod generally leaves a corresponding mark or groove at the base of the finished candle, whereby a hand made article can be readily recognised. The moulds being somewhat warmed so as not to chill the candle material too quickly, the molten substance is poured into the trough so as to fill all the moulds, and also part of the trough to allow for shrinkage; the whole is then set by to cool, and when the candles are sufficiently set, the contents of the trough are scooped out with a trowel. Preferably, the frame carrying the series of moulds is immersed in a water tank so as to facilitate the chilling, the temperature of the water varying with the nature of the material used and the dimensions of the candles moulded; it being usually necessary that the solidification should go on at a particular rate, otherwise a crystalline structure may be developed by too slow cooling, injuring the appearance of the candle, or cracking may occur with too rapid chilling. When the candles are completely set, the frame is removed from the water, and the candles extricated by removing the pegs and inverting the frame, when they mostly fall out of themselves owing to the moulds being slightly conical; if sticking occur, gently tapping the mould generally suffices to dislodge the candle. Including "threading"—i.e., setting the wicks

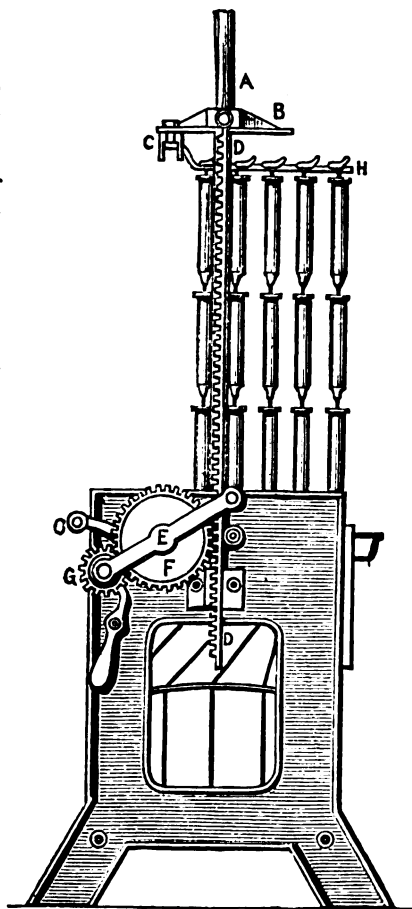

Fig. 99.

When the candles are completely set, the frame is removed from the water, and the candles extricated by removing the pegs and inverting the frame, when they mostly fall out of themselves owing to the moulds being slightly conical; if sticking occur, gently tapping the mould generally suffices to dislodge the candle. Including "threading"—i.e., setting the wicks

in position by hand (by passing it through the lower orifice and pulling it upwards by means of a wire)—filling, and emptying, hand frames can only be worked off about once in an hour, or somewhat less frequently. In the later “continuous” candle moulding machines, three times this speed is attained, much time being saved by a device whereby the wick is passed continuously at stated intervals through the mould, a candle being cast at each period, and when set, lifted upwards so as to draw the wick into position for the next moulding, so that a string of candles, one after the other, is cast around each wick.

Fig. 99 represents Royan’s form of continuous wick moulding machine as used in Germany (Schädler); as each batch of candles is cast and becomes sufficiently hard, they are lifted upwards out

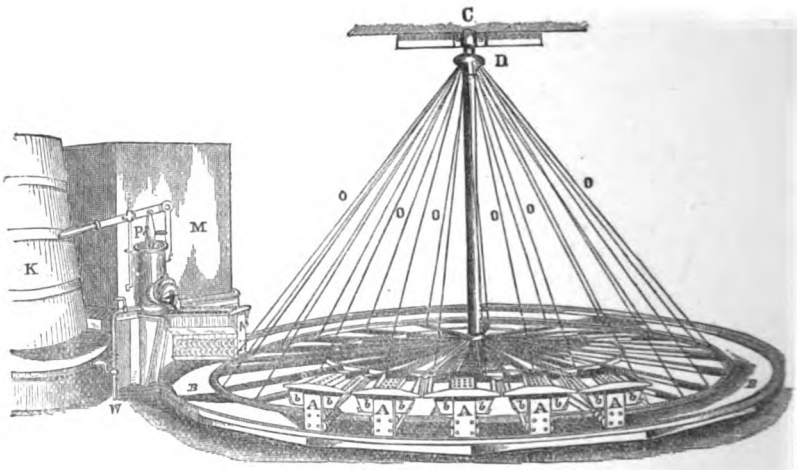

Fig. 100.

of the moulds by means of a rack and pinion which elevates a platform to the under side of which the wicks are fastened by a series of clips; in this way the wicks are always kept gently stretched along the axes of the moulds; several successive tiers of candles are thus moulded without altering the attachments. When the platform reaches its highest elevation the wicks are severed below the lowest tier, and the strings of candles removed from the clips that support them; the platform is then lowered and the wick ends affixed to the clips, and the operations commenced afresh.

Fig. 100 represents “Camp’s moulding wheel,” a combination of the principle of the “Edinburgh wheel” used for dipping candles with this “continuous” moulding action; this arrangement has been somewhat extensively used in America (Christiani). A revolving

horizontal wheel, B, is supported by iron rods, O O O, and turns on a pivot, C, attached to the roof. A series of moulding frames, A A A, are supported by the wheel, regularly arranged radiating from the centre; the troughs, *b b*, *b b*, surrounding these can be filled with water heated to any required temperature by means of steam pipes, or if need be cooled with ice. Just below the tips of the moulds are the rows of bobbins of wick, the ends of which, to begin with, are drawn upwards by hand and adjusted in the axes of the moulds. When all the moulds are ready the discharge valve, P, of a tank of melted candle material, M, is opened so as to fill one of the mould frames in position underneath; the wheel is then pushed round until the next mould frame is in position under the spout, when this is similarly filled; and so on with all in turn. By the time the last frame is filled the first will have cooled sufficiently to enable the candles to be cautiously withdrawn and laid over in grooves cut for their support in the ledges of the frame; as this is done the wicks are drawn upwards, so that the moulds are threaded ready for the next filling. The mould frame thus emptied is refilled with melted candle material; and similarly with the next, so that the wheel is revolved a second time, each mould frame being filled in succession as before; when all the frames are filled the candles lying over in the grooves (by this time perfectly hard and solid) are cut off and removed, and these now filling the moulds are pulled upwards and made to take their place.

The moulding machines in use at the present day in the larger factories are mostly constructed on the "piston" principle, whereby the candles when sufficiently set are mechanically expelled from the moulds by means of a series of pistons rising up therein and lifting the candles out. Fig. 101 represents the general mode of action, identical in principle with that of an ordinary "lifting pump" without the valve, excepting that the piston-rod is below instead of above; the piston is hollowed conically so as to form the mould of the candle tip; the wick passes upwards through the tubular piston-rod. A series of moulds is arranged in a convenient frame or trough into which water can be run heated by means of steam, or artificially cooled as may be requisite according to the temperature at which the moulds are to be kept, which varies with the nature of the candle material.



Fig. 101.

Fig. 102 represents a moulding machine containing two such troughs arranged parallel, each containing a double row of moulds set in a suitable frame with the piston-rods all depressed; this is effected by connecting them all to a horizontal shelf

(driving plate) capable of being raised or lowered at will by means of a handle working a pinion gearing into a rack ; as the shelf is raised the four rows of candles are simultaneously lifted upward by the ascent of the pistons. As they rise they pass through four series of grooved jaws or "nippers" slightly open ; at the summit of the elevation these jaws close, gently grasping and supporting the candles, the grooves being lined with felt or preferably india rubber. The handle is then turned the reverse way so as to depress the pistons to the lower ends of the moulds ; the wicks attached at the upper ends to the rows of candles supported by the nippers are consequently stretched in the axes of the moulds, having been unwound from the bobbins beneath during the ascent of the candles.

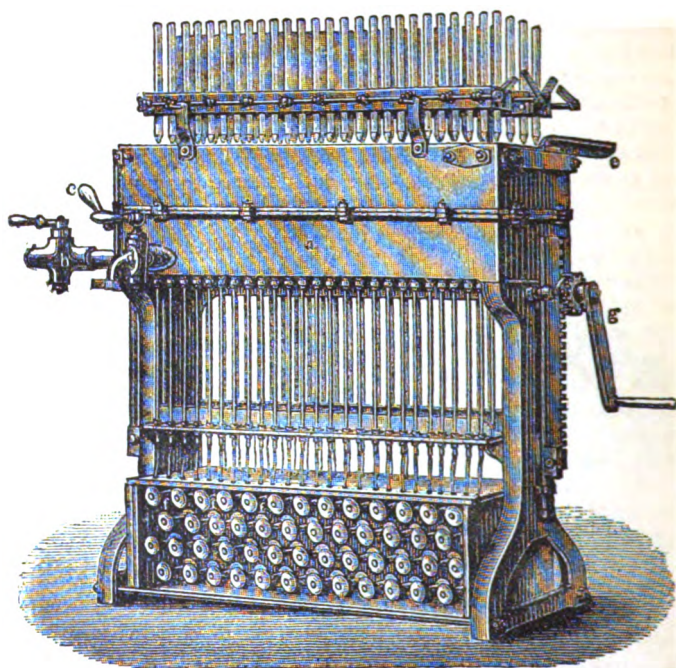

Fig. 102.

To commence operations, each wick is hooked up by means of a wire through the hollow piston-rod and fixed in the axis of the mould, as in the hand frame ; melted candle material is then poured into the moulds, and when set the candles are lifted out (by raising the pistons) and held by the nippers, the wicks being thus pulled upwards into position for the next casting ; the

pistons are then depressed, sliding over the wicks as they descend; the temperature of the water trough is adjusted if requisite, and a new batch of candles cast by pouring in more melted candle material. When this has set sufficiently to keep the wick in its central position without extraneous aid, the upper rows of candles held by the nippers are detached by cutting through the wicks; the nippers holding the candles are then opened and the candles extracted, or, preferably, are lifted off (being detachable) and emptied on to a table, &c. The nippers are then replaced and the process repeated until the wick bobbins are exhausted.

The lengths of the candles thus moulded in a given set of cylinders can be regulated at will by simply raising the driving plate by means of set screws, so as to shorten the distance between each piston and the top of the corresponding mould, and thus form a shorter candle; or *vice versâ*. When the butt ends of the candles are required to be conical (so as to fit into any sized stick), a special kind of cutting machine is employed to shave down the ends. If the cone is to be of greater diameter at its base than the rest of the candle, a special modification of the mould is employed (*infra*).

The chief skill required in working the candle moulding machine lies in properly regulating the temperature, the *modus operandi* varying in this respect with the material. With pure stearine (*i.e.*, solid fatty acids with just enough paraffin wax, beeswax, or vegetable wax, or other similar material to "break the grain," and prevent or diminish crystallinity), the moulds are kept at a temperature slightly below the setting point of the candle material, which is poured in on the point of congealing, well stirred so as to form a gruel-like mass. The workman generally judges the temperature by simply putting his hand into the water trough surrounding the moulds, cooling it by running in a little cold water if requisite, or *vice versâ*. With paraffin wax, on the other hand, the moulds must be heated by hot water or steam well above the melting point of the wax (usually up to 80° to 85°, or about 170° F.), whilst the wax also should be hotter than its fusing point; when the moulds are filled, the surrounding hot water is run off and cold water run in instead, whereby the material is quickly chilled, and the peculiar translucency and lustre desired is attained. In certain cases this effect is heightened by alternately admitting hot and cold water into the water box, the precise mode of operating varying somewhat according as paraffin scale of relatively low melting point is used, or harder paraffin (cerasin, ozokerite, &c.) of higher melting point, with or without the addition of a few per cents. of stearic acid, either for the purpose of serving as vehicle for colour (p. 405), or to prevent the tendency to soften and bend often shown by pure paraffin candles, even at temperatures considerably below the

fusing point. In some cases, where mixed materials are used with stearine in larger quantity, intermediate temperatures are employed for the water box. In Britain, paraffin candles have largely driven fatty acid candles out of the market on account of their greater cheapness, but this is not so much the case on the Continent.

Moulded *tallow* candles were formerly somewhat largely employed, but latterly have mostly gone out of use along with dips on account of the objections to glycerides as combustible matter (p. 394). The same remark also largely applies to "composites," or mixtures of free fatty acids and glycerides, except for night lights (p. 406).

Spermaceti candles are usually moulded in much the same way as paraffin wax candles, the material being heated above its melting point and run into hot moulds, which are then rapidly chilled by means of cold water. During the latter part of the last century and the earlier portion of the present one they were in some considerable amount of use by the wealthier classes; but like wax candles, their use is but small nowadays as compared with candles of "stearine" and paraffin wax. With properly adjusted wicks they burn with considerable regularity and brightness, and are accordingly selected as the practical standard for photometric observations; a "standard candle" being one burning 120 grains of spermaceti per hour.

For certain special forms of candle particular modifications of the moulding machine are requisite; thus stearine candles, especially on the Continent, are often cast with longitudinal internal spaces or tubes, which tend to prevent "guttering" whilst burning. Spiral exteriors are also much in favour; formerly these were made by lathing cylindrical candles cast in the ordinary moulds; but in the more recent machines the pistons are made to ascend by a screw motion, the moulds themselves being correspondingly grooved, so that the candles are screwed out of the moulds. For "self-fitting" butt ends (Fig. 103), where the thickest portion of the conical part is of greater diameter than the rest of the candle, the frame above described requires modification. Fig. 104 represents a machine for moulding self-fitting butt end candles, constructed by E. Cowles, of Hounslow, where the butts are shaped by a separate series of moulds

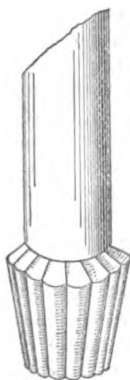

Fig. 103.

fitting on the top of the cylindrical moulds, and ultimately lifted off from the conical candle ends by means of the chain, the candles being then raised by the piston and held in removable nipping frames in the usual way. This arrangement does not permit of the wick being run continuously; after each batch of candles is cast

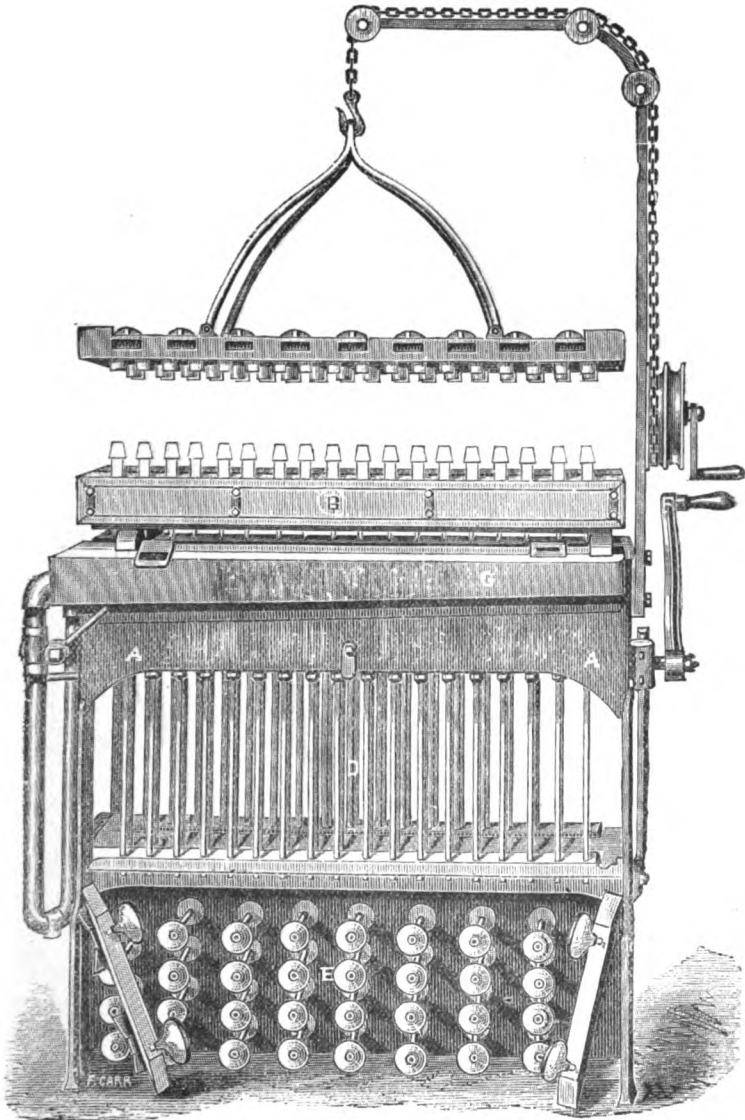

Fig. 104.

the wicks must be severed, and after removal of the nipping frames and candles the butt mould lowered into position ; each wick is then hooked up through its appropriate butt mould and clamped centrally in the axis of the mould so as to be ready for the next casting. This involves much trouble and delay, besides causing the waste of a short length of wick at each candle end.

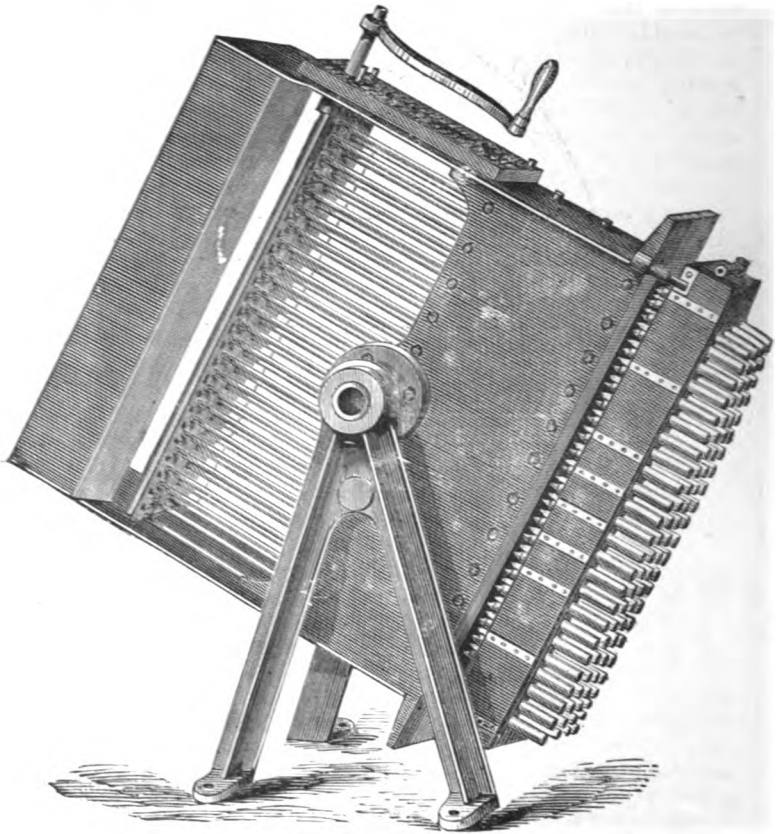

Fig. 105.

These objections are obviated by making the butt end moulds in two halves, separable from one another at will, so as to permit of the candles rising upwards when the half-moulds are apart, but tightly closing together and fitting accurately on the tops of the piston moulds when required ; the opening and shutting is simply effected by the motion to or fro of a separate handle. When the moulds are closed, the melted candle material is poured in ; after

setting, this handle is moved back so as to open the butt moulds ; the main handle actuating the pistons is then moved so as to raise the candles into the nipping frame ; the pistons are then lowered, the butt moulds closed, and a new casting proceeded with.

Fig. 105 represents a "turnover" machine, swinging on trunnions, so that when a hard candle material has been run into the moulds and has partly solidified round the sides, the machine can be tipped over so as to allow the still liquid portion of the material in the centre of the moulds to run out, thus leaving hollow candles which are then filled in with softer material ; candles of comparatively easily fusible substance can thus be prepared with an outer casing of less fusible material which prevents the guttering that would otherwise occur.

Stearine candles are comparatively seldom tinted, being gener-

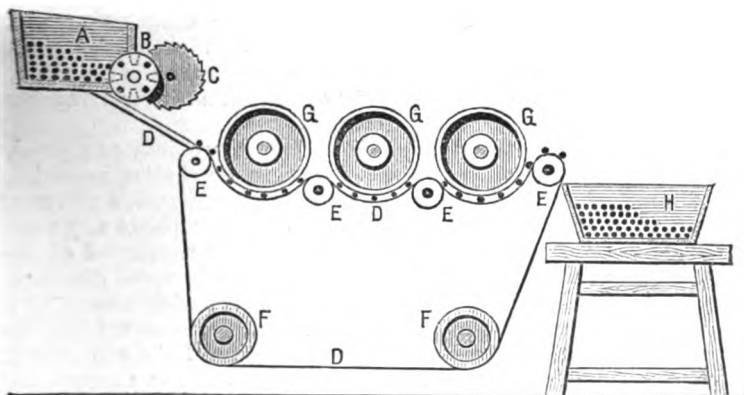

Fig. 106.

ally burnt uncoloured ; sometimes, however, they are tinted yellowish with gamboge, &c. For tinted paraffin candles, however, a considerable demand exists. Formerly the candle material was coloured by incorporating a small quantity of very finely ground pigment ; but this is now never done if it can be avoided, as the wick almost invariably becomes clogged after burning a short time, so that a smoky less luminous flame results. Coaltar dyestuffs are generally preferred, as far as possible free from fixed mineral constituents ; in many cases these will not dissolve in pure paraffin wax ; but by dissolving them in fused stearic acid, and incorporating a little of the solution with the melted paraffin, the latter can usually be readily tinted any required depth of shade.

In the case of stearine and wax candles, and sometimes with other varieties also, an extra degree of gloss and polish is some-

times given to the surface by rubbing and rolling them by hand or between cloth-covered rollers, &c.; several machines have been constructed for this purpose. Fig. 106 indicates a simple arrangement where the candles are gradually passed out of the tray, A (by means of the grooved roller, B) on to the endless cloth, E D E D, and rolled between the cloth-covered rollers, G G G, and the cloth; the latter moves in such a direction as to carry the candles forward towards the tray, H, whilst the rollers, G G G, revolve in a contrary direction so as to rub and polish the surfaces of the candles. A small circular saw, G, trims the bases of the candles as they emerge from the tray, A. Paraffin candles as a rule are sufficiently smooth and glossy when properly moulded without any additional polishing.

Nightlights.—The use of “mortars,” or mortuary candles, for burning in death chambers, &c., is very ancient, wax tapers being the form usually employed until comparatively recently, when the use of short stumpy candles of peculiar composition and construction became general for burning at night under such circumstances that whilst only a feeble illumination is requisite, the flame is required to burn steadily and constantly for a number of hours together.

Two different forms of “nightlights” are now chiefly employed, one set in a case of paper, wood-shaving, or similar material, sufficiently fluid-tight to prevent the melted combustible material from running out; the other cast into shape without any such covering. The wick in each case is generally supported at the base by a “sustainer,” consisting either of a little metal disc with a small central perforation through which the wick passes, or a similar small plaster of Paris plate, &c., the object being to prevent the wick from falling over when the light has nearly burnt out so that little or no solid grease is left to support the wick. The nature of the materials burnt varies considerably; for encased nightlights substances are generally chosen the fusing points of which are not extremely high, so that the cost is less; while for nightlights of the “pyramid” kind without cases, substances of comparatively high melting points are preferable.

Different manufacturers vary considerably in the way in which their nightlights are prepared. In some instances the pasteboard or wooden case is simply filled up with melted candle material from a can after the bit of wick and “sustainer” are fixed in position by means of a drop of melted grease applied after the wick has been passed upwards through a minute hole in the bottom of the box: such nightlights are generally placed in a saucer of water when burnt. Others are moulded round the wicks in much the same fashion as ordinary longer candles; whilst others are cast as solid cylinders of fatty matter, through the centre of which a hole is perforated; the wick previously threaded on a little bit of tinfoil, is passed upwards through the perforation,

and fixed in position sufficiently securely by a blow carefully given with a peculiar kind of hammer: these are generally burnt in glass dishes without water. Palmitic acid from palm oil, highly pressed coker stearine, and pressed tallow are the materials most frequently employed as combustible matter; wicks of rush pith peeled so that two small strips of peel are left adherent on opposite sides are used for some, the effect of the strips being to turn outwards in burning, giving a well-shaped flame.

Spills for lighting candles, &c., are generally drawn by much the same process as that above described for thin wax tapers (p. 389), the wicks being wound on a drum after passing through the melted composition and a suitable sized drawplate. After cutting to length the ends are "feathered" by dipping into hot water so as to melt half an inch or so of composition and giving a vigorous shake or jerk which dislodges most of the melted materials, slightly separating the strands in so doing.

Medicated Candles.—For the purpose of impregnating the air of sickrooms, &c., with disinfecting vapours, certain substances are sometimes intermixed with the candle material—*e.g.*, *iodine* and *eucalyptus oil*. In the latter case the effect is produced by the volatilisation of eucalyptol from the hot cup of melted grease at the base of the wick, that portion which is burnt in the flame being ineffective; with iodine, the free element is evolved from the flame itself, hydriodic acid, if formed, being largely decomposed again by the heat. Sulphur* has been used in similar fashion, sulphur dioxide being formed on combustion.

* A spirit lamp charged with a mixture of alcohol and carbon disulphide affords a convenient means of producing sulphur dioxide for disinfecting chambers, &c.

§ 7. The Soap Industry.

CHAPTER XVIII.

MATERIALS USED IN THE MANUFACTURE OF SOAP.

FATTY MATTERS AND ALKALIES.

THE raw fatty materials employed in any large quantities for the manufacture of ordinary household soaps and those used for technical purposes, such as wool-scouring, &c., are far less numerous than the different varieties of oleaginous matters used for culinary, edible, and miscellaneous purposes throughout the world in different countries; but almost every day new sources of oily and fatty matters from abroad are brought to light, many of which only require suitable development to furnish excellent material for soapmaking as well as for more superfine uses.

The leading substances of animal origin in largest use for soapmaking are the fats of the sheep and ox (tallow), horse grease, damaged hog's lard, kitchen grease, and similar materials derived from trade refuse of different kinds (such as tannery, bone-boiling and gluemaking greases), together with seal and whale oils, cod and shark liver oils, fish oils of various kinds, and such like materials, including sewage grease, egg yolks, and greases recovered from soapsuds, wool washing, engine waste cleansing, &c. Amongst the more prominent materials of vegetable origin may be mentioned the oils and butters derived from olives; cotton, sesamé, sunflower, rape, and linseeds; arachis and cokernuts; palm fruits and kernels; niger and poppy seeds; castor beans and almonds; and in lesser degree a large variety of analogous substances, mostly either the "foots" formed during refining (p. 261), or the inferior qualities obtained as the last hot pressings, or by treatment with carbon disulphide and similar solvents, of the partially exhausted mass from which oils of finer quality, suitable for superior applications, have been previously expressed or otherwise obtained; it being a sort of general

axiom that any kind of greasy or oleaginous matter can be made into soap of a more or less useful and valuable character, even when fit for no other applications, the coarsest kind of cart grease and such like rough lubricants alone excepted.

A certain amount of higher priced soaps (toilet and special varieties) is also prepared from less coarse fatty matters, in some instances from materials of the finest qualities; but the quantity of these superior grades made bears only a small proportion to the total amount of ordinary coarser soaps manufactured for scouring and laundry purposes (*vide* Chap. xx.)

Alkalies.—The term *alkali* is usually traced to the Arabic *Al kali*, a name applied to a particular plant (a kind of “glass-wort”), the ashes of which abound in potash, and have consequently been used from the earliest ages, not only for the manufacture of glass (whence the English trivial name), but also for laundry and detergent purposes generally. The term “potash,” indeed, connotes much the same idea, being originally applied to the soluble part of woodashes dissolved out by water and recovered by boiling down the solution in a pot; pearlash being the same material subjected to further purification so as to whiten it. Even at the present day crude ashes from vegetable combustibles are often used as a detergent without purification, the earthy and calcareous insoluble matters present serving rather to aid scouring purposes; thus, cigar ash furnishes a very effective dentifrice.*

The difference in character (from the soap boiler's point of view) between the alkali contained in the ashes of inland vegetation (potash) and that present in marine plant ash (soda), appears to have been known to a considerable extent to the alchemists of the earlier and middle ages of the Christian era; although the essential chemical differences between the two, and the practical identity of the latter with the mineral product *natron*, were probably not so clearly understood. The effect of treatment with quicklime so as to render “mild alkali” (carbonate) “quick” or “caustic,” and the superior action of the quickened product on oleaginous matters, so as to form soap, were also more or less imperfectly known to them. At the present day the alkalies used in soapmaking are generally (though not invariably) used in the caustic condition because of this more rapid action; but saponification can be effected by carbonated alkalies if sufficient time be allowed, or if the action be accelerated by increased heat and pressure. In all probability the action of an alkaline carbonate essentially consists in the forma-

* A few years ago an ancient tomb was dug up in Rome; a quantity of what appeared to be ashes were found therein, which were appropriated by one of the workmen for his wife to use in washing. It subsequently transpired that the ashes were the remains of the Emperor Galba, who was cremated some eighteen centuries ago (*Times*).

tion of soap and bicarbonate; thus with stearin and sodium carbonate—

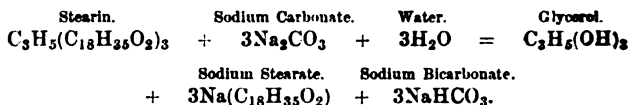

Under the influence of heat the bicarbonate breaks up into carbon dioxide, water, and neutral carbonate, which last then reacts as before—

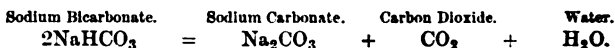

Ammonia usually exerts a considerably less energetic saponifying action on most kinds of fatty matters than the fixed alkalis; whilst lime, magnesia, zinc oxide, lead oxide, and similar materials, although useful in the preparation of earthy and metallic soaps for other purposes (candlemaking, preparation of lead plasters, &c.), are not used in the direct manufacture of ordinary soaps; excepting in so far as small quantities of lime, iron, and other metallic soaps are often present therein as impurities derived from the water or the materials and utensils used, &c.

Formerly the manufacture of alkali, especially soda, was very frequently conjoined with that of soap; but of late years it has become more usual to dissever the two trades, the soapboiler purchasing either caustic or carbonated alkali from the alkali manufacturer instead of preparing it himself. At one time the chief source of potash was the ashes of terrestrial vegetation (whence the term "vegetable alkali"); but mineral potassium chloride (chiefly from the Stassfurth deposits) is now largely employed as raw material, being converted into potassium carbonate by the Leblanc process.* Similarly, in the earliest ages, soda (*natron*) was derived from saline efflorescences on the soil, whence the term "mineral alkali;" subsequently, the ashes of seaweeds and marine plants furnished a cheaper source known as "barilla;" whilst latterly, soda produced by the method of Leblanc, or by the more recent "ammonia process" for converting rocksalt into sodium carbonate, has mostly superseded all other kinds. By either of these processes, "soda ash" (more or less impure anhydrous sodium carbonate) and "caustic soda" (sodium hydroxide) are prepared in the solid state, the latter being usually put up in airtight iron drums for transport and preservation; when caustic liquors of a given strength are requisite, they

* Conversion into sulphate by treatment with sulphuric acid, and subsequent heating of the sulphate with small coal and calcium carbonate, so as to form alkaline carbonate and calcium sulphide (as "black ash"), separated by dissolving out the former by means of water.

are readily prepared by simply dissolving a known weight of the solid caustic soda in a given volume of water, and are then ready for use. When, however, sodium carbonate or potassium carbonate is bought, before caustic leys suitable for soap boiling can be obtained, the operation of "causticising" must be gone through, consisting in dissolving the carbonated alkali in water, adding lime, and boiling up with agitation so that the calcium hydroxide and alkaline carbonate may react on one another in accordance with the equations—

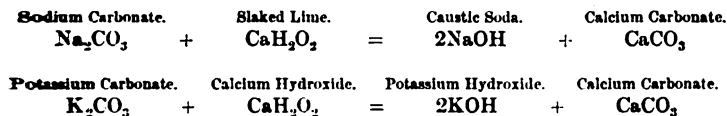

Causticising Process.—In the earlier days of soapmaking the causticising of the alkalies employed was generally effected in the cold; a purer ley being thus obtained from crude "ashes" (rough potashes and "black ash") than when the whole was boiled up together, and then allowed to settle. At the present day this method of treatment is but seldom employed in this country, although still in use on the Continent. In order to carry it out to the best advantage the bottom of the vat is covered with lumps of quicklime, over which water is thrown to slake it; 5 parts of soda ash * for every 6 of quicklime originally used are then shovelled in on the top as uniformly as possible. Another layer of lime is then added, and a second of soda ash, equal in weight to the lime; then a third layer of lime, and a third of soda ash, equal to the second layers. Water, or weak runnings from a previous batch, is then gradually run on, and the whole allowed to stand till next day, when the caustic soda ley formed is run off through a cock at the base of the vat into a settling tank. More water is then added and allowed to stand as before, and finally run off, giving a much weaker liquor either mixed with the first, or used for lixiviating another batch. The lime mud is then stirred up with more water, and the final weak liquor thus obtained used to work a new batch. Conveniently three (or even four) vats are worked in series, exactly like black ash lixiviating tanks; the second liquor from No. 2 is passed through No. 1, coming out of full strength, being itself obtained as the third liquor from No. 3, which is then exhausted. No. 3, being refilled, then becomes No. 1 of a new series; the former No. 1 becomes the second; and so on, methodically. Crude Leblanc soda liquors are much less frequently used now than

* Theoretically, 106 parts of Na_2CO_3 are equivalent to 56 parts of CaO ; a considerable excess of lime, however, is requisite to ensure causticising in the cold. For steam boiling in practice 200 parts of soda ash are used per 100 of quicklime.

was the case before the ammonia soda process had made much headway; when carbonated alkali, free from sulphide, is treated (as when ammonia soda ash is employed, or Leblanc soda liquor prepared from the "salts" that separate on evaporating the liquors obtained on lixiviating black ash), the plant used consists simply of some form of steam vessel, such as an old boiler, provided with an efficient agitator; lumps of quicklime are added (preferably placed on a grating or enclosed in a sort of cage to keep back hard lumps and stones when the lime disintegrates on slaking), and the whole boiled up for one or more hours until the operation is complete, either under pressure in a closed vessel (whereby a considerable saving of fuel and labour is effected) or by means of wet steam in an open pan. If, on the other hand, crude black ash liquors be used (impure sodium carbonate, &c., dissolved out from black ash by water, containing sulphide owing to the reaction of sodium carbonate solution on calcium sulphide), or the "red liquors" obtained as mother liquors when the crude black ash liquor is evaporated until "salts" (mostly sodium carbonate) crystallise out during evaporation, the causticising action of lime is conveniently conjoined with the oxidising action of a current of air blown into the fluid for the purpose of destroying sulphide by conversion into thiosulphate, sulphite, and sulphate; for which purpose a vessel is employed provided at the base with a large rose jet or spiral tube pierced with holes, or a perforated false bottom, through which the air and steam are blown in together so as to keep the whole in agitation and effect the causticising and oxidation simultaneously. Finally, the whole is allowed to stand at rest awhile, so that the "lime mud" (calcium carbonate, &c.) may settle, and the clear caustic alkali solution run off or pumped into tanks for storage. These are generally made of boiler plate rivetted together (Fig. 107). When intended to hold ley for toilet soap,

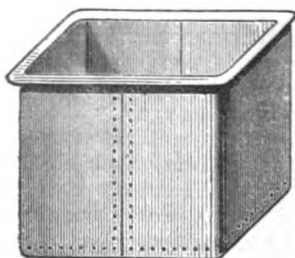

Fig. 107.

Dussauce recommends that they should be lined with sheet lead to prevent possible discoloration of soap through contact of the ley with iron.

In order to causticise the carbonate thoroughly an excess of lime is desirable; the remaining caustic lime in the lime mud, if of sufficient quantity to be worth saving, may be utilised by boiling up again with a fresh batch of carbonated liquors; after allowing

to settle, the clear liquor is pumped off to another pan, where the causticising is finished with another batch of fresh lime, the mud from which operation is again boiled up with

ash carbonated liquor, and so on continuously alternately. The lime mud resulting from the second treatment with carbonated liquors usually contains too little caustic lime to be worth using a third time; but by boiling up with water the adhering soda solution is mostly washed out, and a weak ley obtained, utilised here to dissolve more carbonated alkali, or for other purposes at the factory.*

To causticise sodium carbonate solution thoroughly, the liquor must not be too strong, otherwise a considerable portion of the alkaline carbonate escapes the causticising action of the lime; on the other hand, when the leys are made too weak, the quantity of lime is a subsequently requisite for "salting out" the soap (Chap. xx.) is increased. When the open pan system is adopted, a sufficiently complete degree of causticising is generally effected by using liquors of such strengths that the ley finally obtained has a specific gravity not exceeding about 1.075 to 1.10 (15° to 20° Tw.), although slightly higher strengths, up to specific gravity 1.11 or 1.13 (22° to 25° Tw.), are sometimes made; by causticising under pressure, considerably stronger leys may be effectively prepared, provided that the subsidence of the lime mud and the running off of the clear ley is still effected under the same pressure; thus, with a pressure of 50 lbs. per square inch, caustic ley up to specific gravity 1.16 to 1.20 (32° to 40° Tw.) may be readily prepared, provided this precaution is adopted; otherwise the reverse action goes on, caustic soda reacting on calcium carbonate so as to reproduce sodium carbonate (Parnell). When more concentrated leys are required, they are obtained by quickly boiling down with as little access of air as possible; weaker leys are got by diluting stronger ones with water, or with the very weak liquors obtained by "washing" the lime mud left after running off the caustic liquor—*i.e.*, by adding water to the mud, boiling up, allowing to settle, running off the weak ley thus obtained, and repeating the operation so as to obtain another batch of still weaker washings. The storage tanks in which the caustic leys are kept should be well closed to prevent absorption of carbonic acid from the air; this is sometimes done by pouring a layer of paraffin oil or melted paraffin wax on the ley, of course taking the requisite precautions to avoid any hydrocarbon being drawn off with the ley used for making soap; when properly prepared, no visible disengagement of bubbles of gas should be noticeable on adding sufficient hydro-

* The lime mud finally obtained from soda leys usually retains a notable proportion of sodium carbonate in a form insoluble in water, chiefly as a double carbonate of calcium and sodium. This may be regained in Leblanc alkali works by drying and using the impure calcium carbonate obtained over again in the black ash operation; but in an ordinary soap work, where the residual lime mud is little better than a waste product, the soda thus retained in the lime mud is usually lost.

chloric or other mineral acid to supersaturate the alkali; this serves as a test of completion during the causticising process. In order to know what quantity of alkali is used for a given operation, the tanks are fitted with gauges; so that if the level is reduced by a given number of inches, for instance, it is known that so many gallons of fluid have been run off; the alkaline strength of the fluid being known, the total weight of alkali present in the fluid run off is then known. In general it is more convenient to arrange the ley tanks at an elevation (at the upper part of the factory) so as to run off the leys by gravitation, than to have them in the basement and pump up the leys to the coppers, although this latter arrangement economises space.

Valuation of Alkalinity of Leys.—In order to determine the alkaline strength of soap leys with absolute accuracy volumetric assay with a standard acid solution must be employed; but for general soapmaking purposes, the specific gravity of the solution is a sufficiently near indication. It should be borne in mind, however, that the specific gravity is only to be trusted as an indication of alkalinity in cases where the character of the liquor is always sensibly the same—i.e., where the proportion of saline matters other than caustic alkali (sodium or potassium chloride, sulphate, &c.) does not vary much. This is usually the case when soda ash, &c., of a tolerably uniform quality is always employed; but when different grades are used at different times leys may easily be obtained of considerably different alkaline strengths although of the same specific gravity. Thus, if soda ash be used, made by the ammonia process and containing 57.56 per cent. of “anhydrous soda” ($\text{Na}_2\text{O} = 62$), equivalent to about 96 per cent. of anhydrous sodium carbonate, Na_2CO_3 , a ley having a given specific gravity (say 1.075) at the ordinary temperature will be notably stronger in alkali, bulk for bulk, than a similar ley prepared from Leblanc soda of say 52 per cent., equivalent to about 89 per cent. of anhydrous carbonate, because the latter contains a larger proportion of sodium salts (chloride, sulphate, &c.), which increase the relative density of the liquor without adding to its alkaline strength. *A fortiori*, if a “48 per cent. soda ash” (i.e., an ash containing alkali equivalent to only 48 per cent. of Na_2O , equivalent to about 82 per cent. of Na_2CO_3) be used, the alkaline strength of the ley will be lower still for the same specific gravity, since, in order to reduce the alkalinity of the ash to “48 degrees” (48 per cent. Na_2O), an extra amount of some diluting agent (usually salt) must be added. Similar remarks obviously apply to potash leys made from potash of different grades, and to caustic soda leys made by directly dissolving solid caustic soda in water; the ley from a “70 per cent. caustic” (containing 70 per cent. $\text{Na}_2\text{O} =$ about 90 per cent. NaOH) will usually be stronger,

bulk for bulk, at a given specific gravity than that from a "60 per cent. caustic" (containing 60 per cent. Na_2O = about 77 per cent. NaOH), except in so far as the difference in strength between the two kinds of caustic is due simply to *water*, and not to saline matters, such as sulphate and chloride.

The following tables exhibit the relationships between the alkaline strengths of *pure* solutions of sodium and potassium hydroxides and carbonates, and their respective specific gravities, at the ordinary temperature (15°C .), or at more elevated temperatures:—

SPECIFIC GRAVITY OF CAUSTIC SODA SOLUTION AT 15° (Tünnermann).

Specific Gravity.	Per Cent. of Na_2O	Specific Gravity.	Per Cent. of Na_2O .
1.4235	30.22	1.2392	15.11
1.4193	29.62	1.2280	14.50
1.4101	29.01	1.2178	13.90
1.4011	28.41	1.2058	13.30
1.3923	27.80	1.1948	12.60
1.3836	27.20	1.1841	12.09
1.3751	26.59	1.1734	11.48
1.3668	25.99	1.1630	10.88
1.3586	25.39	1.1528	10.28
1.3505	24.78	1.1428	9.67
1.3426	24.18	1.1330	9.07
1.3349	23.57	1.1233	8.46
1.3273	22.97	1.1137	7.86
1.3198	22.36	1.1042	7.25
1.3143	21.89	1.0948	6.65
1.3125	21.76	1.0855	6.04
1.3053	21.15	1.0764	5.44
1.2982	20.55	1.0675	4.84
1.2912	19.95	1.0587	4.23
1.2843	19.34	1.0500	3.63
1.2775	18.73	1.0414	3.02
1.2708	18.13	1.0330	2.42
1.2642	17.53	1.0246	1.81
1.2578	16.92	1.0163	1.21
1.2515	16.38	1.0081	1.00
1.2453	15.71	1.0040	1.30

SPECIFIC GRAVITY OF CAUSTIC SODA SOLUTION AT 15°

(Lunge and Hurter).

Specific Gravity.	Grammes of Na ₂ O per Litre.	Specific Gravity.	Grammes of Na ₂ O per Litre.
1·005	3·7	1·260	228·9
1·010	7·5	1·270	240·0
1·020	15·1	1·280	251·0
1·030	22·6	1·290	262·1
1·040	30·2	1·300	273·2
1·050	37·7	1·310	285·4
1·060	45·5	1·320	297·7
1·070	53·2	1·330	309·9
1·080	61·0	1·340	322·2
1·090	68·8	1·350	334·4
1·100	76·5	1·360	347·2
1·110	84·3	1·370	360·1
1·120	92·1	1·380	372·9
1·130	100·5	1·390	385·7
1·140	109·6	1·400	398·5
1·150	118·6	1·410	411·8
1·160	127·7	1·420	425·0
1·170	136·8	1·430	438·2
1·180	145·8	1·440	451·4
1·190	154·9	1·450	464·6
1·200	164·0	1·460	479·9
1·210	174·7	1·470	495·3
1·220	185·5	1·480	510·6
1·230	196·3	1·490	525·9
1·240	207·0	1·500	541·2
1·250	217·8		

INFLUENCE OF TEMPERATURE ON THE SPECIFIC GRAVITY OF
CAUSTIC SODA SOLUTION.

Temperature.	Specific Gravity.								
Degrees C.	1·015	1·030	1·060	1·100	1·150	1·200	1·250	1·320	1·370
0	1·015	1·030	1·060	1·100	1·150	1·200	1·250	1·320	1·370
10	1·012	1·027	1·057	1·097	1·146	1·195	1·245	1·315	1·365
20	1·009	1·024	1·054	1·093	1·142	1·190	1·240	1·310	1·360
30	1·007	1·022	1·052	1·091	1·138	1·186	1·235	1·305	1·355
40	1·003	1·018	1·048	1·087	1·136	1·181	1·231	1·299	1·350
50	0·999	1·014	1·044	1·082	1·129	1·177	1·226	1·294	1·345
60	·994	1·009	1·039	1·077	1·124	1·173	1·221	1·288	1·339
70	·988	1·003	1·033	1·071	1·118	1·168	1·216	1·283	1·334
80	·982	·997	1·027	1·065	1·112	1·162	1·211	1·277	1·329
90	·977	·992	1·022	1·059	1·107	1·156	1·206	1·271	1·324
100	·971	·986	1·016	1·053	1·101	1·151	1·200	1·265	1·319

SPECIFIC GRAVITY OF CAUSTIC POTASH SOLUTION AT 15° (*Tünnermann*).^o

Specific Gravity.	Percentage of		Specific Gravity.	Percentage of	
	KHO.	K ₂ O.		KHO.	K ₂ O.
1·3300	33·69	28·29	1·1437	16·85	14·15
1·3131	32·35	27·16	1·1308	15·50	13·01
1·2966	31·00	26·03	1·1182	14·15	11·88
1·2805	29·65	24·90	1·1059	12·80	10·75
1·2648	28·30	23·76	1·0938	11·46	9·62
1·2493	26·95	22·63	1·0819	10·11	8·49
1·2342	25·61	21·50	1·0703	8·76	7·36
1·2268	24·93	20·94	1·0589	7·41	6·22
1·2122	23·59	19·80	1·0478	5·96	5·00
1·1979	22·24	18·67	1·0369	4·72	3·96
1·1839	20·89	17·54	1·0260	3·67	2·83
1·1702	19·54	16·41	1·0153	2·02	1·70
1·1568	18·20	15·28	1·0050	0·674	0·566

SPECIFIC GRAVITY OF CAUSTIC POTASH SOLUTION AT 15°.
(*Lunge and Hurter*).

Specific Gravity.	Grammes per Litre.		Specific Gravity.	Grammes per Litre.	
	K ₂ O.	KOH.		K ₂ O.	KOH.
1·007	7	9	1·252	284	338
1·014	14	17	1·263	297	353
1·022	22	26	1·274	308	368
1·029	30	36	1·285	321	385
1·037	39	46	1·297	335	398
1·045	49	58	1·308	349	416
1·052	57	67	1·320	363	432
1·060	66	78	1·332	377	449
1·067	74	88	1·345	394	469
1·075	83	99	1·357	410	487
1·083	92	109	1·370	425	506
1·091	100	119	1·383	440	522
1·100	111	132	1·397	457	543
1·108	119	143	1·410	472	563
1·116	129	153	1·424	490	582
1·125	140	167	1·438	509	605
1·134	150	178	1·453	530	631
1·142	159	188	1·468	549	655
1·152	170	203	1·483	571	679
1·162	181	216	1·498	593	706
1·171	192	228	1·514	615	731
1·180	203	242	1·530	635	756
1·190	214	255	1·546	655	779
1·200	226	269	1·563	681	811
1·210	237	282	1·580	706	840
1·220	248	295	1·597	731	870
1·231	260	309	1·615	759	902
1·241	272	324	1·634	789	940

SPECIFIC GRAVITY AT 15° C. OF SODIUM CARBONATE SOLUTION
(Lunge and Hurter).

Specific Gravity.	Percentage of		Specific Gravity.	Percentage of	
	Na ₂ O.	Na ₂ CO ₃ .		Na ₂ O.	Na ₂ CO ₃ .
1·005	0·28	0·47	1·080	4·42	7·57
1·010	0·56	0·95	1·085	4·70	8·04
1·015	0·84	1·42	1·090	4·97	8·51
1·020	1·11	1·90	1·095	5·24	8·97
1·025	1·39	2·38	1·100	5·52	9·43
1·030	1·67	2·85	1·105	5·79	9·90
1·035	1·95	3·33	1·110	6·06	10·37
1·040	2·22	3·80	1·115	6·33	10·83
1·045	2·50	4·28	1·120	6·61	11·30
1·050	2·78	4·76	1·125	6·88	11·76
1·055	3·06	5·23	1·130	7·15	12·23
1·060	3·34	5·71	1·135	7·42	12·70
1·065	3·61	6·17	1·140	7·70	13·16
1·070	3·88	6·64	1·145	7·97	13·63
1·075	4·16	7·10	1·150	8·24	14·09

SPECIFIC GRAVITY AT 30° C. OF CONCENTRATED SODIUM CARBONATE SOLUTION (Lunge and Hurter).

Specific Gravity.	Percentage of		Specific Gravity.	Percentage of	
	Na ₂ O.	Na ₂ CO ₃ .		Na ₂ O.	Na ₂ CO ₃ .
1·140	7·97	13·62	1·230	12·48	21·33
1·150	8·46	14·47	1·240	12·98	22·20
1·160	8·96	15·32	1·250	13·49	23·07
1·170	9·46	16·18	1·260	14·00	23·93
1·180	9·96	17·04	1·270	14·49	24·77
1·190	10·46	17·89	1·280	14·98	25·61
1·200	10·97	18·75	1·290	15·47	26·45
1·210	11·47	19·61	1·300	15·96	27·29
1·220	11·97	20·47	1·310	16·45	28·13

POTASSIUM CARBONATE (*Gerlach*).

Percentage of K_2CO_3	Specific Gravity at 15°	Percentage of K_2CO_3	Specific Gravity at 15°	Percentage of K_2CO_3	Specific Gravity at 15°
1	1·0091	19	1·1327	37	1·3828
2	1·0183	20	1·1929	38	1·3948
3	1·0274	21	1·2034	39	1·4067
4	1·0366	22	1·2140	40	1·4187
5	1·0457	23	1·2246	41	1·4310
6	1·0551	24	1·2352	42	1·4434
7	1·0645	25	1·2458	43	1·4557
8	1·0740	26	1·2568	44	1·4681
9	1·0834	27	1·2679	45	1·4804
10	1·0928	28	1·2789	46	1·4931
11	1·1026	29	1·2900	47	1·5059
12	1·1124	30	1·3011	48	1·5186
13	1·1222	31	1·3126	49	1·5314
14	1·1320	32	1·3242	50	1·5441
15	1·1418	33	1·3357	51	1·5573
16	1·1510	34	1·3473	52	1·5705
17	1·1612	35	1·3589	52·024	1·57079
18	1·1714	36	1·3708		

The above tables only apply to *pure* solutions of alkaline carbonates and hydroxides; with commercial substances containing other neutral saline matters (chloride, sulphate, &c.) a correction is necessary to allow for the increment in specific gravity brought about by the presence of these impurities without any corresponding increase in alkaline strength: the amount of this correction necessarily varies with the proportion and nature of the saline matter present, and consequently no very accurate allowance on this score is practicable in most cases; but an approximation sufficiently near for most practical purposes is obtained by assuming that the effect of a given quantity of neutral saline matter in increasing the specific gravity is the same as that of the same quantity of actual alkali; so that if it is known that a given sample contains n per cent. of neutral saline matters, together with $100 - n$ per cent. of actual alkali (reckoned on the sum of alkali and salts as 100), the correction is obtained by subtracting from the tabular number corresponding with the particular specific gravity n per cent. of its value. Thus, for example, if a solution of sodium carbonate be made from a soda ash, &c., where the saline impurities (sulphate, chloride, &c.) jointly represent 5 per cent. of the total solids dissolved (the sodium carbonate consequently representing 95 per cent.), the amount of sodium carbonate given in the table for a given specific gravity is to be reduced by 5 per cent. of its value. Similarly if the actual caustic soda, $NaOH$, in a sample of commercial caustic be 90 per cent., and the saline impurities

10 per cent., of the total soluble solid matters present (exclusive of moisture), the tabular number must be decreased by 10 per cent. of its value. Where more exact valuations are requisite, as is sometimes necessary in order to avoid using excess or deficiency of alkali, specific gravity indications must be discarded, and the results of alkalimetric assays substituted for them; for this purpose a normal or seminormal solution of hydrochloric or sulphuric acid is convenient, using an indicator not affected by carbon dioxide (litmus employed in hot solution, cochineal, methyl orange, &c.)*

English, French, and German Degrees.—A peculiar trade custom obtains in Britain whereby the alkaline strength of soda ash and caustic soda is represented as higher than the truth to the extent of about 1.32 per cent. or 1 part in 76. This is brought about by the incorrect assumption that the atomic weight of sodium is 24 instead of 23; whence the percentage of Na_2O in pure sodium carbonate, Na_2CO_3 , is reckoned as $\frac{64}{108} \times 100 = 59.26$, instead of $\frac{62}{106} \times 100 = 58.49$. Hence 58.49 parts of soda are reckoned as 59.26, thus giving an error in excess of 0.77 in $58.49 = 1.32$ in 100. A still more erroneous mode of calculation was recently current in some districts, based on the same assumption that $\text{Na} = 24$; only in this case the molecular weight of Na_2O was reckoned as 64 instead of 62, thus giving an error in excess of 2 parts in $64 = 3.23$ parts in 100, more than twice the former error.

In Germany the alkaline strength is usually expressed in "degrees" representing the percentage of pure Na_2CO_3 equivalent to the alkali present—*i.e.*, pure sodium carbonate would be a soda ash of 100°. In France "Descroizilles degrees" are in use, representing the quantity of pure sulphuric acid, H_2SO_4 , neutralised by 100 parts of soda ash—*i.e.*, pure sodium carbonate, Na_2CO_3 , would represent a product of strength equal to $\frac{98}{106} \times 100 = 92.45$ Descroizilles. The relationships between Descroizilles and German degrees and the true percentage of anhydrous soda ($\text{Na}_2\text{O} = 31$, not affected by the above named errors in excess due to English trade customs) are consequently given by the formula—

* When it is required to determine the amount of alkali present in the caustic and in the carbonated state, two assays are requisite; in one case the total alkali is determined contained in a given volume of fluid; in the other the same volume of solution is boiled with barium chloride or nitrate, and after cooling, made up to double the original bulk with water; after subsidence or filtration the caustic alkali in half the total fluid is determined, and the amount found doubled and subtracted from that found in the first assay. The difference represents the carbonated alkali present with more or less accuracy according as access of carbonic acid from the air has been avoided during the operations.

$$\begin{array}{rcc} S & = & D & = & G \\ 31 & = & 49 & = & 53 \end{array}$$

where S is the alkaline strength expressed as percentage of Na_2O (equivalent 31—sometimes spoken of as the strength in "Gay Lussac degrees"); D the same in Descroizilles degrees (equivalent of $\text{H}_2\text{SO}_4 = 49$); and G the same expressed in German degrees (equivalent of $\text{Na}_2\text{CO}_3 = 53$).

From this formula result the equations—

$$\begin{aligned} S &= \frac{31}{49} D = 0.6327 D \\ &= \frac{31}{53} G = 0.5849 G \\ D &= \frac{49}{31} S = 1.5806 S \\ &= \frac{49}{53} G = 0.9245 G \\ G &= \frac{53}{31} S = 1.7097 S \\ &= \frac{53}{49} D = 1.0816 D \end{aligned}$$

The following table represents the same relationships—

S.	D.	G.	S.	D.	G.
2	3.16	3.42	42	66.39	71.81
4	6.32	9.84	44	69.55	75.23
6	9.48	10.26	46	72.71	78.66
8	12.64	13.68	48	75.87	82.07
10	15.81	17.10	50	79.03	85.48
12	18.97	20.52	52	82.19	88.90
14	22.13	23.94	54	85.35	92.32
16	25.29	27.36	56	88.52	95.74
18	28.45	30.78	58	91.68	99.16
20	31.61	34.20	60	94.84	102.58
22	34.77	37.62	62	98.00	106.01
24	37.93	41.04	64	101.16	109.43
26	41.09	44.46	66	104.32	112.85
28	44.25	47.88	68	107.48	116.27
30	47.42	51.29	70	110.64	119.69
32	50.58	54.71	72	113.81	123.10
34	53.74	58.13	74	116.97	126.52
36	56.90	61.55	76	120.13	129.94
38	60.06	64.97	77.5	122.50	132.50
40	63.22	68.39			

Calculation of Quantity of Alkaline Ley requisite for Saponification.—When an alkaline solution of known strength (either determined by titration, or inferred from the specific

gravity after correction of the tabular value for saline impurities) is to be used for converting into soap a given kind of fatty matter or mixture of fats, &c., the quantity requisite for exactly saponifying a given weight of fat depends not only on the alkalinity of the ley but also on the mean saponification equivalent of the fatty matters (p. 158); the lower the value of this latter quantity the more alkali will be required, the relationship being indicated thus—Let E be the mean saponification equivalent of the fats, &c., used; then E units of weight of fat will be equivalent to 31 units of Na_2O (or to 40 of NaOH , 47.1 of K_2O , or 56.1 of KOH). Let 1,000 parts by weight of alkaline ley be equivalent to a_1 parts of Na_2O (or to a_2 of NaOH , a_3 of K_2O , or a_4 of KOH)—i.e., let a_1 (a_2 , a_3 , or a_4) be the permillage of alkali in the ley. Then E units of weight of fat will obviously be equivalent to $31 \times \frac{1,000}{a_1}$ units of weight of ley (or to $40 \times \frac{1,000}{a_2}$, $47.1 \times \frac{1,000}{a_3}$, or $56.1 \times \frac{1,000}{a_4}$); whence one part of fat is equivalent to $31 \times \frac{1,000}{a_1} \times \frac{1}{E} = \frac{31,000}{a_1 \times E}$ parts of ley (or to $\frac{40,000}{a_2 \times E}$, $\frac{47,100}{a_3 \times E}$ or $\frac{56,100}{a_4 \times E}$ parts). Thus one part by weight of cokernut oil of mean saponification equivalent 215 will be exactly saponified by $\frac{40,000}{220 \times 215} = 0.846$ parts of caustic soda ley containing 220 per mille of NaOH ; whilst one part of linseed oil of mean saponification equivalent 291.5 will correspond with $\frac{47,100}{150 \times 291.5} = 1.077$ parts of a potash ley containing total active alkali (caustic + carbonated) equivalent to 150 per mille of K_2O ; and so on.

When the alkalinity of the leys is expressed as *parts by weight per unit of volume* (grammes per litre, pounds per gallon,* &c.) the above calculation still applies in slightly modified form. Let the alkaline ley contain b_1 grammes of Na_2O per litre (b_2 grammes of NaOH , b_3 of K_2O , b_4 of KOH), then E grammes of fat are equivalent to $\frac{31}{b_1}$ litres of ley (or to $\frac{40}{b_2}$, $\frac{47.1}{b_3}$, or $\frac{56.1}{b_4}$ litres); whence 1 gramme of fat represents $\frac{31}{b_1 \times E}$ (or $\frac{40}{b_2 \times E}$

* A solution of anything containing n grammes per litre (n milligrammes per c.c. or n kilogrammes per cubic metre), contains n pounds per hectogallon (100 gallons), since 1 gallon of water weighs 10 lbs. Hence when laboratory estimations are made, as usual, on the metrical system, the results can, if required, be referred to pounds and gallons for practical British works' use in a very simple way.

$\frac{47.1}{b_3 \times E}$ or $\frac{56.1}{b_4 \times E}$ litres of ley; or 1 kilogramme represents $\frac{31,000}{b_1 \times E}$ ($\frac{40,000}{b_2 \times E}$, $\frac{47,100}{b_3 \times E}$ or $\frac{56,100}{b_4 \times E}$) litres. Thus, one kilo. of cokernut oil ($E = 215$) would be exactly saponified by $\frac{40,000}{200 \times 215} = 0.930$ litres of caustic soda solution of such strength that 1 litre = 200 grammes NaOH; or 1 kilo. of linseed oil ($E = 291.5$) would correspond with $\frac{47,100}{157.0 \times 291.5} = 1.029$ litres of potash ley of which 1 litre = 157.0 grammes K_2O .

The following table gives the values of $\frac{40,000}{E}$ and $\frac{56,100}{E}$ for values of E between 190 and 400; by its means the number of litres, x , of caustic soda (or potash) solution can be readily calculated, requisite for the saponification of a kilogramme of any fatty mixture the mean saponification equivalent of which is \bar{E} , by the simple formula—

$$x = \frac{n}{N},$$

where n is the tabular number corresponding with E, and N the number of grammes of NaOH (or of KOH) contained in a litre of the ley used:—

E.	$\frac{40,000}{E}$	Difference.	$\frac{56,100}{E}$	Difference.
190	210.5	...	295.2	...
200	200.0	10.5	280.5	14.7
210	190.5	9.5	267.2	13.3
220	181.8	8.7	255.0	12.2
230	173.9	7.9	243.9	11.1
240	166.7	7.2	233.7	10.2
250	160.0	6.7	224.4	9.3
260	153.8	6.2	215.8	8.6
270	148.1	5.7	207.8	8.0
280	142.8	5.3	200.4	7.4
290	137.9	4.9	193.5	6.9
300	133.3	4.6	187.0	6.5
310	129.0	4.3	181.0	6.0
320	125.0	4.0	175.3	5.7
330	121.2	3.8	170.0	5.3
340	117.6	3.6	165.0	5.0
350	114.3	3.3	160.3	4.7
360	111.1	3.2	155.8	4.5
370	108.1	3.0	151.6	4.2
380	105.3	2.8	147.6	4.0
390	102.6	2.7	143.8	3.8
400	100.0	2.6	140.25	3.55

Thus, suppose a mixture of tallow, palm oil, and cokernut oil to have the mean saponification equivalent 250; then $n = 160$, and the number of litres of caustic soda solution requisite to saponify a kilogramme is $\frac{160 \cdot 0}{N}$, where N is the number of grammes of NaOH contained in a litre of the ley; if $N = 160$ the quotient is, obviously, 1,000—*i.e.*, 1 litre exactly is required; whilst for stronger and weaker solutions, where N is respectively 320 and 80, the corresponding quotient values are 0.500 and 2.000—*i.e.*, exactly 0.5 litre of the stronger fluid is required, and 2.0 litres of the weaker one.

If the saponification equivalent is not exactly indicated by the table, the value is readily obtained by interpolation by means of the difference columns without introducing any material error; thus a commercial "oleine" (impure oleic acid) of which the saponification equivalent is 282.5 corresponds with a value for $\frac{40,000}{E}$ of $142.8 - 0.25 \times 4.9 = 141.6$; hence, if a soda ley containing 293.6 grammes of NaOH per litre be used ($N = 293.6$), $\frac{141.6}{293.6} = 0.482$ litre of ley will contain alkali exactly corresponding with 1 kilo. of fatty matter.

Obviously, the above formula $x = \frac{n}{N}$ will also enable the number of parts by weight of ley to be calculated, requisite to saponify one part by weight of fatty matter of mean equivalent E , if N denote the permillage of NaOH (or of KOH) in the ley. Thus in one of the examples above quoted, one part of cokernut oil of equivalent 215 represents a value for $\frac{40,000}{215}$ of $190.5 - 0.5 \times 8.7 = 186.1$; whence the quantity of soda ley at 220 per mille of NaOH, equivalent thereto is $\frac{186.1}{220} = 0.846$ part, as before.

When it is required to use fatty matters and alkaline leys in as nearly as possible equivalent quantities so as to avoid excess of either constituent, calculations such as the foregoing afford the simplest method of arriving at the relative quantities requisite. In practice, when the same kind of operation is to be repeated over and over again as a matter of routine, the fatty matter employed being sensibly of the same quality throughout, it usually suffices to gauge the tanks and vessels employed once for all by means of calculations founded on these principles, and preferably checked by careful analyses of the resulting products; the weight of fatty matters taken and their mean saponification equivalent being practically constant for each operation, the volume of alkaline ley used is slightly

increased or diminished below that corresponding with the original gaugings according as the alkalimetric test of the liquor (or the value deduced from its specific gravity) shows that it is a little below or above its normal strength—i.e., that pertaining to the original gaugings.

When it is required to calculate the amount of sodium or potassium hydroxide or carbonate equivalent to a given amount of anhydrous oxide, or *vice versa*, the following formulæ may be employed, based on the molecular weights—

Na	=	23		K	=	39.1
Na ₂ O	=	62		K ₂ O	=	94.2
NaOH	=	40		KOH	=	56.1
Na ₂ CO ₃	=	106		K ₂ CO ₃	=	138.2

Let a given weight A of Na₂O be equivalent to B of NaOH and C of Na₂CO₃; and let a given weight D of K₂O be equivalent to E of KOH and F of K₂CO₃: then—

To reduce		Formula.	
NaOH to Na ₂ O	A =	$\frac{62}{2 \times 40}$	B = 0.7750 B
Na ₂ CO ₃ to Na ₂ O	A =	$\frac{62}{106}$	C = 0.5849 C
Na ₂ O to NaOH	B =	$\frac{2 \times 40}{62}$	A = 1.2903 A
Na ₂ CO ₃ to NaOH	B =	$\frac{2 \times 40}{106}$	C = 0.7547 C
Na ₂ O to Na ₂ CO ₃	C =	$\frac{106}{62}$	A = 1.7097 A
NaOH to Na ₂ CO ₃	C =	$\frac{106}{2 \times 40}$	B = 1.3250 B
KOH to K ₂ O	D =	$\frac{94.2}{2 \times 56.1}$	E = 0.8396 E
K ₂ CO ₃ to K ₂ O	D =	$\frac{94.2}{138.2}$	F = 0.6816 F
K ₂ O to KOH	E =	$\frac{2 \times 56.1}{94.2}$	D = 1.1911 D
K ₂ CO ₃ to KOH	E =	$\frac{2 \times 56.1}{138.2}$	F = 0.8119 F
K ₂ O to K ₂ CO ₃	F =	$\frac{138.2}{94.2}$	D = 1.4671 D
KOH to K ₂ CO ₃	F =	$\frac{138.2}{2 \times 56.1}$	E = 1.2317 E

Thus a solution of sodium hydroxide of specific gravity 1.206 containing 13.3 per cent. of NaOH will contain $13.3 \times 0.775 = 10.3$ per cent. of Na₂O; one containing 21.5 per cent. of K₂CO₃ is equivalent to another containing $21.5 \times 0.8119 = 17.46$ per cent. of KOH; and so on.

The following analogous formulæ may be used to calculate the quantity of soda equivalent to a given weight of potash or *vice versa*. Let H be a given quantity of sodium carbonate and I the potassium carbonate equivalent thereto; similarly let J be a given amount of sodium hydroxide and K the potassium hydroxide corresponding therewith; and let L be a given quantity of Na_2O , and M the K_2O equivalent thereto. Then—

$$\begin{array}{l} \text{Carbonates, . . .} \\ \text{Hydroxides, . . .} \\ \text{Anhydrous oxides,} \end{array} \left\{ \begin{array}{ll} \text{H} = \frac{106}{138.2} & \text{I} = 0.7670 \text{ I} \\ \text{I} = \frac{138.2}{106} & \text{H} = 1.3038 \text{ H} \\ \\ \text{J} = \frac{40}{56.1} & \text{K} = 0.7130 \text{ J} \\ \text{K} = \frac{56.1}{40} & \text{J} = 1.4025 \text{ K} \\ \\ \text{L} = \frac{31}{47.1} & \text{M} = 0.6582 \text{ L} \\ \text{M} = \frac{47.1}{31} & \text{L} = 1.5194 \text{ M} \end{array} \right.$$

Thus 10 per cent. of K_2O in a given soap is equivalent to $10 \times 0.6582 = 6.582$ per cent. of Na_2O . A liquor containing 8 per cent. of NaOH is of the same alkaline strength as one containing $8 \times 1.4025 = 11.22$ per cent. of KOH ; and so on.

CHAPTER XIX.

SOAPMAKING PLANT.

HEATING APPLIANCES.

THE plant and appliances requisite for the manufacture of soap vary somewhat according to the nature of the process used and the scale on which it is conducted. Formerly the vessels (usually known as "pans," "coppers," or "kettles") in which the boiling operations were conducted were uniformly mounted over free fires, so that the flame produced by the combustion of fuel in a fireplace placed beneath the pan was made to play over the rest of the bottom and part of the sides of the pan by means of a suitably arranged circular flue provided with a damper for the purpose of regulating the draught. Several coppers were usually mounted side by side, so that the products of combustion of their respective fires passed into the same common tunnel or flue lead-

ing to the main chimney of the works. At the present day this system of free firing is comparatively seldom applied in the larger soap factories, the coppers being more frequently heated by steam supplied from a special boiler, and in some cases super-heated before use. Fig. 108 gives a general idea of the disposi-

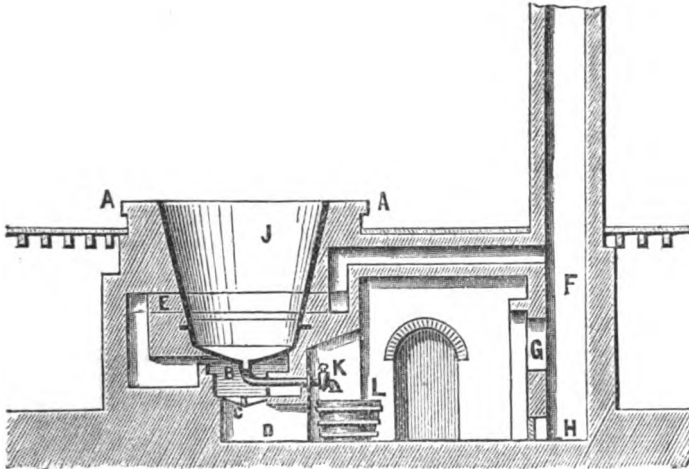

Fig. 108.

tion of the arrangements adopted for a free-fired pan. The pan, J, is mounted in masonry over the fireplace, B, placed centrally beneath it, a nearly circular flue, E, carrying the flame round the lower part of the pan to the chimney, F; C is the grate or range of firebars supporting the fuel, and D the ashpit. The leys, &c., are drawn off as required by the tube and draw-off cock, K; the level of the flooring or staging round the pan, A, A, is raised so that the top of the pan projects upwards some 3 feet.

Fig. 109 represents a cast iron pan of slightly different type, A, also mounted so as to be heated by free firing; in this case the fireplace, B, is not placed centrally beneath the pan, but somewhat in front of it, the heating being chiefly effected by the hot air chamber, E, in which the products of combustion circulate round and under the

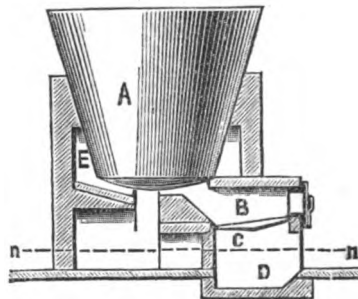

Fig. 109.

base of the pan before passing away to the flue. C, firebars; D, ashpit.

In the case of modern steam heated pans, the steam is applied in various ways. Heating by "*wet*" steam consists in blowing steam at a sufficient pressure direct into the mass to be heated, so that the water produced by the condensation of the steam dilutes the whole until the temperature rises so high that the steam simply blows through without becoming materially condensed; for most general boiling purposes a *wet steam coil* is thus used, consisting of an iron pipe descending to near the bottom of the copper and terminating in a ring perforated with holes through which the steam issues, bubbling up through the mass and producing a very effective agitation and intermixture of the contents when the heat is sufficient to cause the steam to blow through. In some districts this *wet steam coil* is accordingly spoken of as the "*blowpipe*;" superheated steam is some-

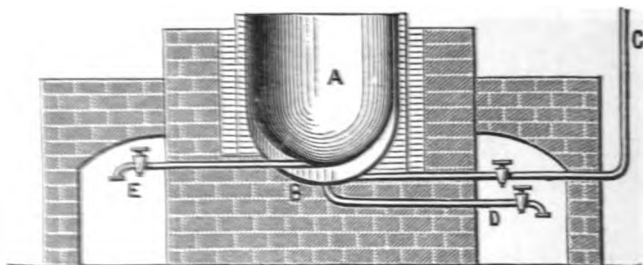

Fig. 110.

times employed instead of steam supplied direct from the boiler, so as to diminish the amount of water condensation.

Heating by "*dry*" steam consists in causing steam (either direct from a high pressure boiler, or preferably for many purposes, superheated) to circulate through a sort of spiral tube or coil arranged in the lower part of the copper; the water condensed in the coil accordingly does not pass into the heated mass, thereby diluting the leys, &c., but is blown off along with the exit steam. Dry steam is also sometimes employed to heat an external jacket usually only surrounding the lower part of the pan: Fig. 110 indicates the kind of arrangement—C, steam supply pipe; D, pipe and cock for drawing off condensed water; A, copper; B, steam jacket at base of copper; E, draw off pipe from copper. A mechanical stirring arrangement to keep the mass agitated is conveniently added.

In order to facilitate intermixture of materials in the pan whilst heating up by dry steam an appliance known as "*Moritt's steam twirl*" is much used. Fig. 111 represents one form of arrangement applied to a comparatively shallow copper sup-

ported by a wooden frame work, A A, B B. The steam from the steam pipe, G, passes into a hollow spindle, D D E, the central part of which is blocked, so that the steam is obliged to pass through the convoluted tubes, K K, K K, braced together by cross pieces, H H H, which also serve as stirring vanes. By means of the bevel wheels, L L, worked from the shaft and pulley, M N, the twirl is set in motion, so that the contents of the pan are thoroughly agitated whilst being heated up. The condensed water blows off at E with the surplus steam, whilst C is the discharge cock of the pan. The same appliance can also be used with wet steam, the convoluted tubes being pierced with holes so as to allow part of the steam to escape directly into the mass of material.

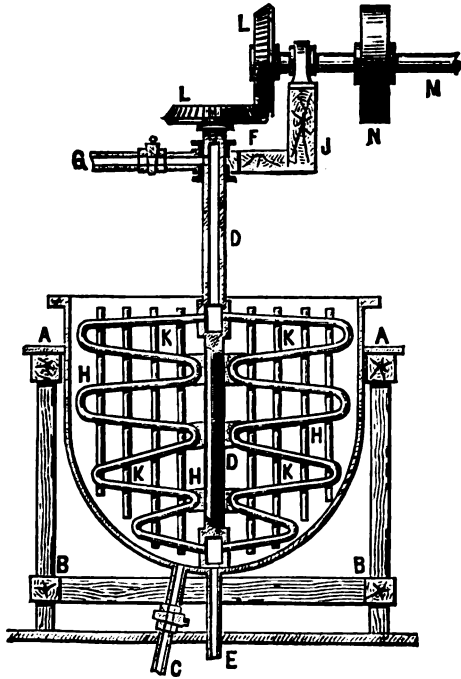

Fig. 111.

Soap Coppers.—Formerly the vessels in which soap and leys were boiled together were made of various kinds of materials; sometimes of masonry, iron bottoms being provided for heating by free fire; sometimes of cast iron, like the pan represented in Fig. 109, or of wrought iron plates rivetted together subsequently, or of wooden staves strongly bound together like enormous tubs, wet steam being the source of heat.

These forms, however, were mostly adapted only for use with quantities of material small in comparison with those in use at the present day, when charges of 30 to 40 tons and upwards of fatty matters are not uncommon; a more recent form of soap kettle is a cylindrical or conical cauldron with somewhat rounded apex, placed base upwards, constructed of boiler plates well rivetted together, as indicated in Fig. 112; the degree of slope of the sides (regulating the ratio between the top and bottom

diameters) and the relation between the depth and maximum diameters vary somewhat in different countries—*e.g.*, soap kettles

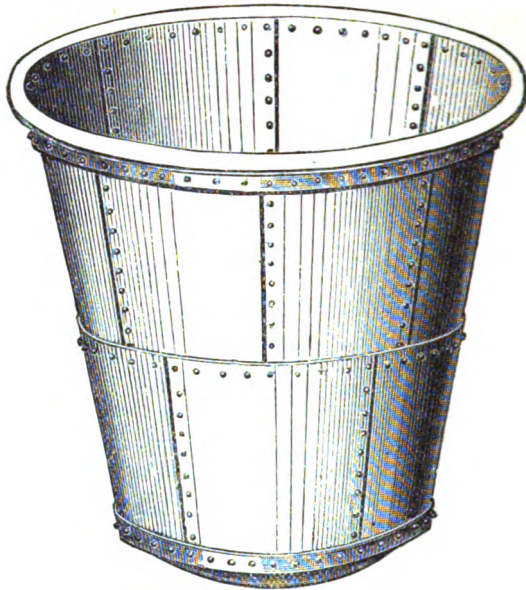

Fig 112.

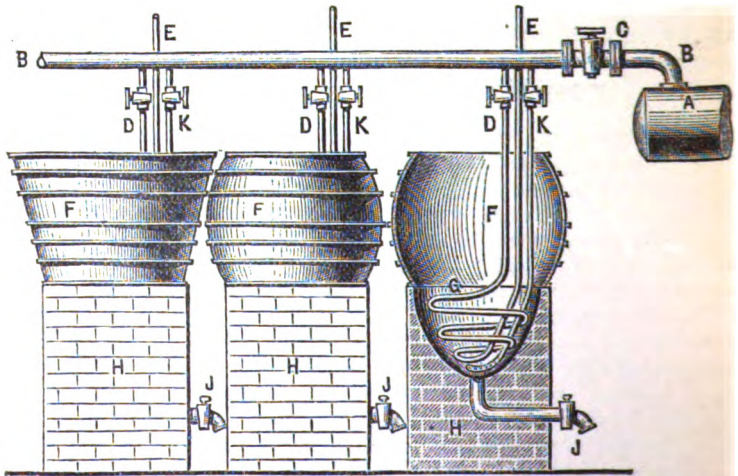

Fig. 113.

of this pattern in America are generally from two to three times as deep as they are wide, sometimes filling a building of two or three stories; whilst in Britain the depth rarely exceeds once and half times the diameter, still shallower pans being often used. A copper 15 feet diameter and 15 feet deep will turn out 20 to

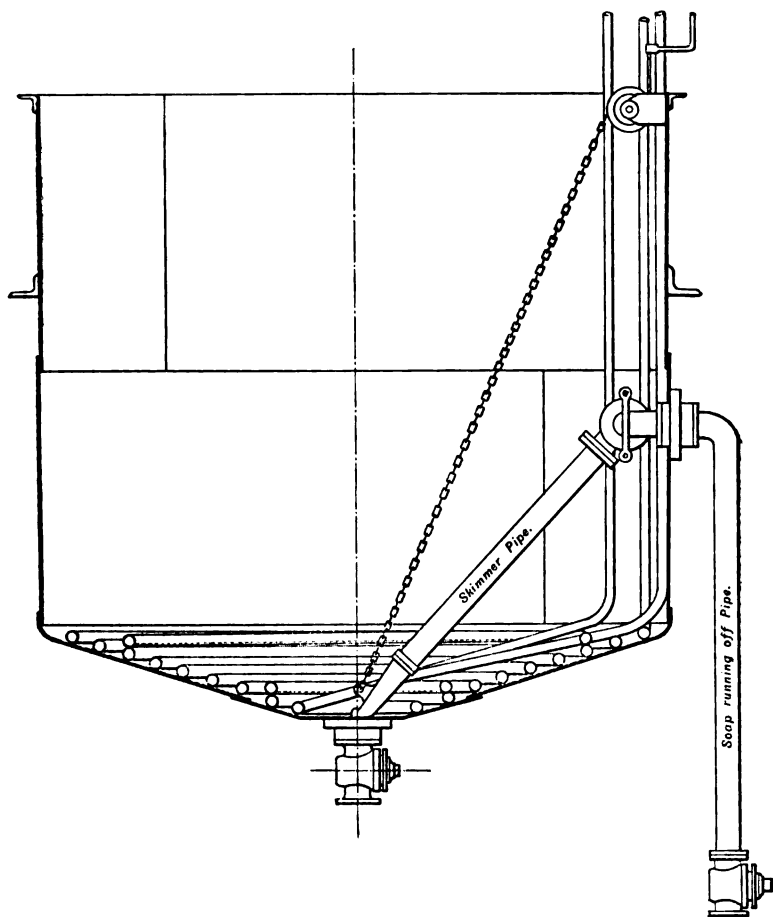

Fig. 114.

30 tons of soap, a usual rule being to allow 6 cubic feet capacity (about 37.5 gallons) for each 100 lbs. weight of fatty matters treated, or about 135 cubic feet (nearly 850 gallons) per ton; so that a copper holding some 2,500 cubic feet (upwards of 15,000 gallons) will suffice for about 18 tons of fatty matters yielding 25 to 30

tons of soap according to the amount of water contained therein. Fig. 113 represents "Morfit's Steam Series," a set of three coppers supplied with both sets of steam coils (wet and dry). B B is the steam main supplied from the boiler, A; K is the wet steam pipe; and D F G the dry steam coil. The lowest part of the

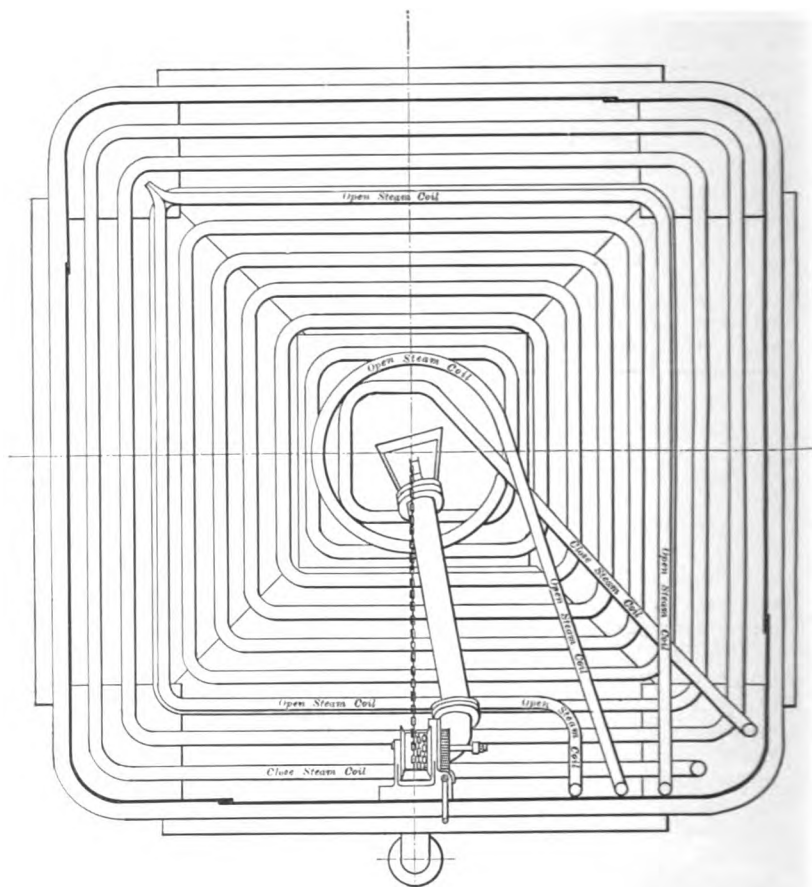

Fig. 115.

copper is usually provided with a narrower basin or hat-shaped downward prolongation for the more easy collection and separation of watery leys, &c.; in the figure it is represented as connected with a draw off tube, H, provided with a cock, J. F F F represent "Curbs" (*infra*) of different shapes to prevent boiling over.

Figs. 114 and 115 represent a modern form of pan for heating with either dry or wet steam as required, constructed by Messrs. W. Neill & Son, of St. Helens, Lancashire. This is a square tank made of steel plates rivetted together, with rounded corners and dished bottom, the square form being preferably employed as taking up less room than the circular shape requisite in the case of free-fired coppers provided with flues running round the lower part of the pan (Fig. 108). The pan is fitted with wet and dry steam coils, and a cock at the bottom for running off spent leys. A "skimmer pipe" is provided, working on a swivel joint, and capable of being adjusted at any required height by a supporting chain; as represented in the figure, the fluid soap is run off by gravity through a down pipe; but if required a pump can be connected at the elbow instead, a cock being affixed to shut off connection when the pump is not at work.

An airblast has been employed by Dunn for the purpose of intermixing the ley and fatty matters during the preliminary stage of "killing the goods," and the subsequent operations when free-fired pans are employed, whereby tumultuous boiling is largely avoided; the air was introduced by a "blowpipe" arranged in much the same way as the more modern wet steam coil. The process was said to answer well; but has nowadays fallen into disuse through the substitution of steam-heated pans for free-fired kettles.

Curb and Fan.—With certain kinds of materials, and particularly at certain stages of the operation, tumultuous boiling up or "bumping," and vigorous frothing are apt to occur, more especially when oleine soap is made by the direct addition of hot carbonated leys to free oleic acid (red oils, *vide* Chap. xx.), and during the "graining" or "cutting" of boiled soaps—*i.e.*, the throwing them out of watery solutions by addition of salt (*vide* Chap. xx.) Two appliances are of considerable utility in diminishing the chance of loss by boiling over under such conditions. One, known as the "curb," is simply a temporary expansion of the upper part of the pan, consisting of a conical, circular, or barrel-shaped addition bolted on so as virtually to amplify considerably the dimensions of the copper at the top. Fig. 113 represents a cone, F, of wooden staves, hooped together with iron, applied to one kettle, and a barrel-shaped analogous curb applied to another.

The other arrangement is termed a "fan," Fig. 116, and consists of a sort of pair of paddle-wheels suspended in the pan at such a depth below the surface as may be requisite, so that as the paddles revolve the froth is broken by them and prevented from rising up and boiling over. Motion is communicated to the paddles by means of a vertical shaft with bevel wheels at top and bottom, the shaft being telescopic so as to admit of being

drawn up and down to adjust the level of the paddle required; it rotates within a tube carrying a Y-shaped

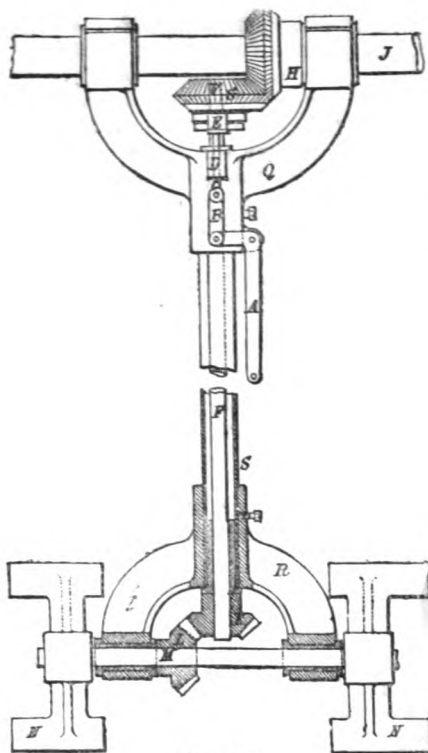

Fig. 116.

it is made into "frames," in which it is allowed to solidify. The pumps used for this purpose are generally of somewhat different construction from the ordinary suction pump used for wells, &c. Fig. 117 represents a rotary soap pump as constructed by Hersee Brothers of Boston. Instead of pumping out the soap, it may more conveniently be run off by gravity by means of the adjustable "skimmer pipe" shown in Fig. 114, the frames being arranged so that their tops are at a level below the elbow joint of the pipe.

A method sometimes used for emptying kettles and raising their contents to a higher elevation was introduced by Gossage, consisting of the application of a cover fitting airtight, and then forcing in compressed air, so as to press the semifluid soap up a pipe the lower end of which dips into the kettle to the required

each end, the being suspended the upper shaft, by which motion communicated to the vertical shaft the bevel wheels the lower Y bearings for the paddles.

Soap Pumps.—

When the operation of soapmaking is finished, and the spent lyes (when they are present) removed by subsidence, &c., the resulting soap usually forms a hot semifluid or pasty mass which, on cooling, more or less thoroughly solidifies to a soft solid substance. In order to facilitate the operation of cutting up the mass into bars and tablets for sale without waste, the hot soap is run by gravitation, or ladled, or pumped out of the copper in which

he paddle,
-shaped f
end, the
suspend
upper h
by m
motion
uted to
raft the
wheels
er Y
s for th
dies.
) F
he
;

depth; the whole arrangement working on the principle of the "acid egg" used in vitriol factories for elevating the acid without employing ordinary pumps.

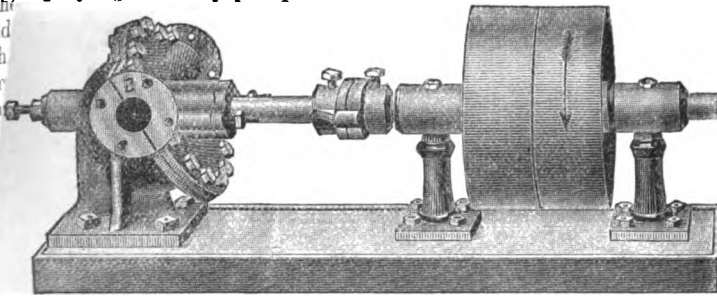

Fig. 117.

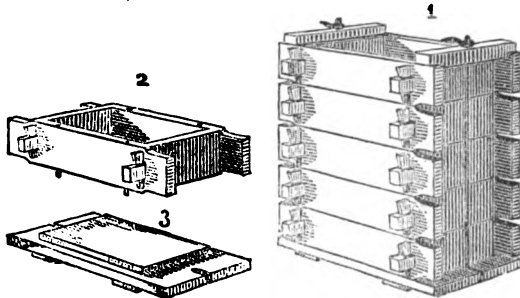

Fig. 118.

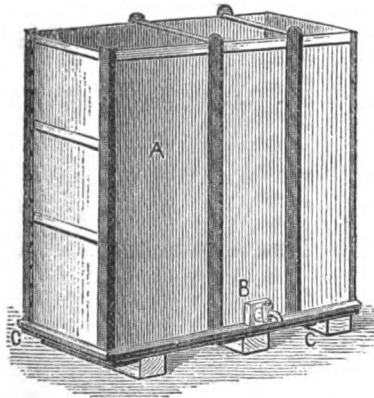

Fig. 119.

The size of the frames employed and the material of which they are composed vary, wood being preferable when slow cooling

... to adjust the level of the paddle
 ... within a tube carrying a Y-shaped

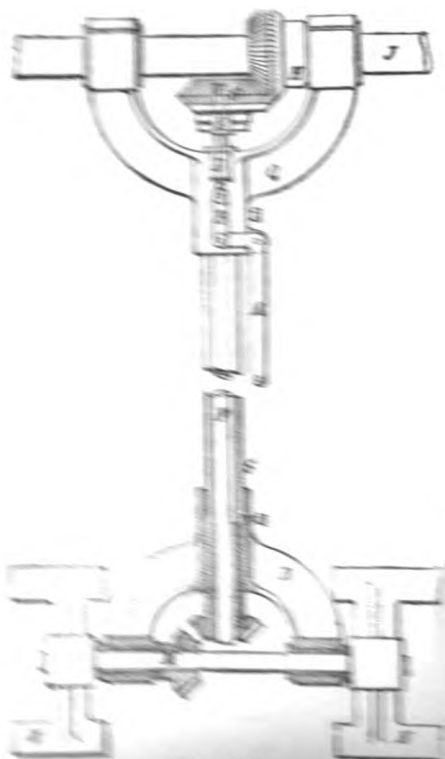

Fig. 119.

each end, the
 being suspend
 the upper h
 shaft, by m
 which motion
 municated to
 tical shaft th
 bevel wheels
 the lower Y
 bearings for th
 the paddles.

Soap P

When the
 soapmaking
 and the
 (when
 remove
 resulting soap
 usually forms a
 semifluid or pasty mass
 which, on cooling more
 or less thoroughly
 solidifies to a soft solid
 substance. In order
 to facilitate the opera
 tion of cutting up the
 mass into lumps and
 tablets for sale without
 waste, the hot soap is
 run by gravitation, or
 ladled, or pumped out
 of the copper in which

... in which it is allowed to solidify. The
 ... are generally of somewhat different
 ... than the ordinary suction pump used for water.
 ... pump as constructed by Ross



... below the elbow

... bottles and
 was introduced by
 cover fitting airtight, and
 to press the semifluid soap
 into the bottle to the top

the level of the paddles
 carrying a Y-shaped
 each end, the
 being suspended
 the upper is
 shaft, by means
 which motion
 communicated to
 vertical shaft the
 level wheels
 the lower Y
 bearings for the
 the paddles.

Soap F
 when the
 saponifying
 and the
 when
 removed

whole arrangement working on the principle of the
 used in oil-mill factories for elevating the seed without
 auxiliary pumps.

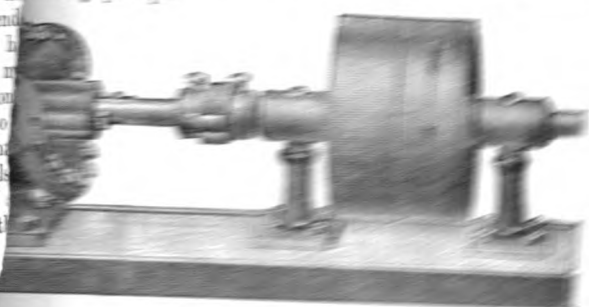

Fig. 17



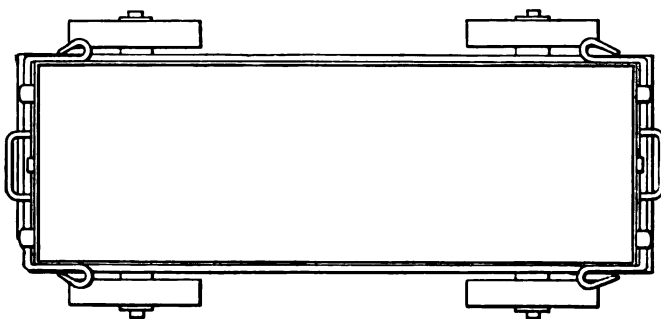
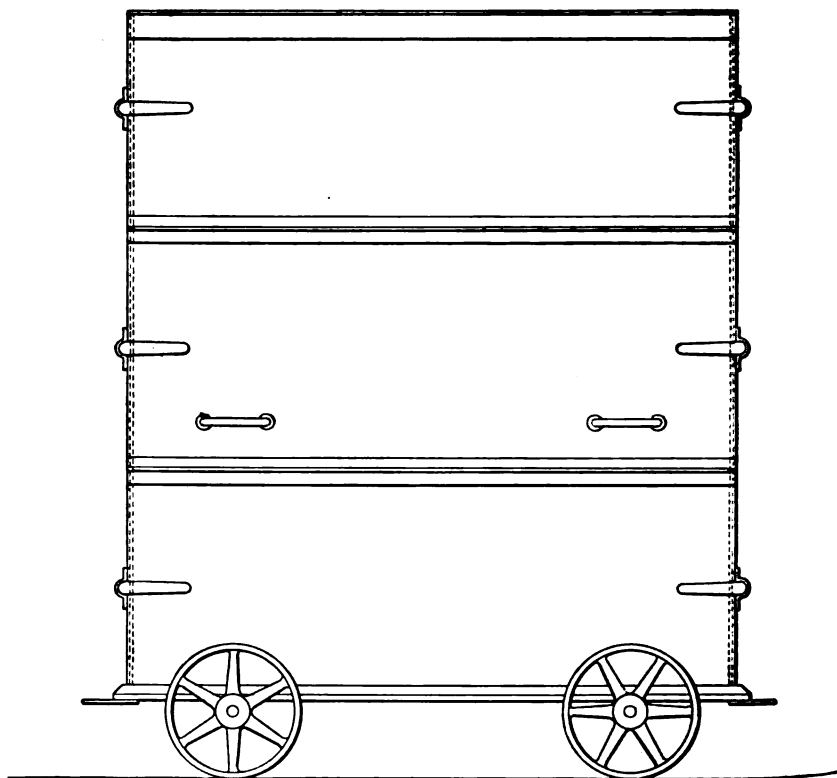

Fig. 120.

is essential, but iron being considerably more convenient in other cases. For toilet soaps, frames holding 1 cwt. or less are often

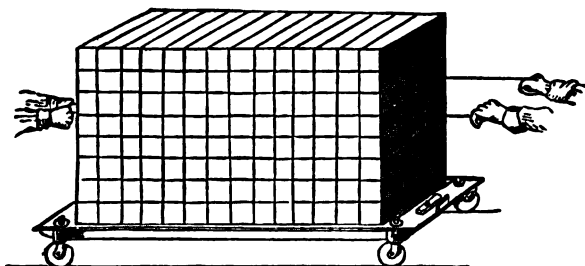

Fig. 121.

employed; for scouring soaps much larger ones, furnishing ultimately a block of cooled soap weighing 8, 10, 15, or more cwts.* Fig. 118 indicates the way in which a wooden frame may be built up of a set of squares pegged together and superposed on a bottom board. Fig. 119 represents a frame constructed of galvanised iron plates where the ends fit into grooves formed by turning round the corners of the side plates, or fitting pieces of angle iron thereto; the side and end plates are similarly fitted to the iron bottom, and the whole kept together by two transverse rods at the top fitted with screws and nuts. Fig. 120 represents an improved form of steel soap frame, mounted on four wheels, and held together by cap fastenings.

When the block of soap has completely cooled down and set solid, the frame is taken to pieces and the block cut into slabs, which are then transversely cut up into bars. When this is done by hand the block is cut in a very simple fashion by simply pulling a looped wire (Figs. 121 and 122) through it horizontally so as to cut through the mass along a series of parallel lines previously marked on the outside by means of a scribe (Fig. 123). Slabbing and barring machines of various patterns are frequently employed for this purpose (Fig. 124). When it is requisite that the soap

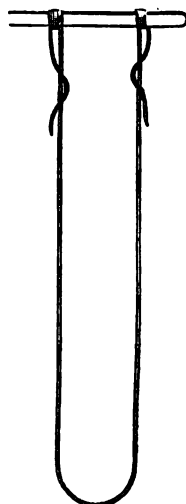

Fig. 122.

* Formerly, the size of the soap frames was fixed by excise laws and regulations, and required to be 45 inches long by 15 wide, inside measurement, and not less than 45 inches deep (usually made 50 to 60 inches deep); so as to hold some 15 to 20 cubic feet, or about 9 to 11 cwts. of soap. Although no longer compulsory, this size is still largely employed.

should cool very slowly in the frame (*e.g.*, in order to promote saponification in making cold process soap—p. 457; or to facilitate mottling—Chap. xx.) the sides of the frame are sometimes padded to keep in the heat (Fig. 125).

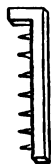

Fig. 123.

The bars of soap into which a block is cut generally weigh about 3 lbs.; they are usually stacked in a hollow pile to dry the outside slightly so as to case-harden them, as it were, or else are stored on lattice work shelves in an open rack allowing free access of air. With very moist soaps, this drying action is apt to go too far, warping the bar out of shape, besides causing it to lose weight largely; accordingly such bars are often "pickled" by immersion in brine, which slightly indurates the outside. Of late years a considerable demand has sprung up for 1 lb. blocks instead of 3 lb. bars; such blocks are generally cut to size and shape and then stamped like toilet cakes in similar machines but of larger size (p. 444). Often the block is grooved in the centre, so that it can be readily broken into two; or three grooves are stamped at equidistant intervals enabling four 4 oz. blocks to be obtained.

Crutching Machines.—Formerly, when it was requisite to stir up soap containing excess of water in the cooling frames to prevent its separating into two liquids, a peculiar hand worked agitator termed a "crutch" was largely used, consisting of a square piece of board with a handle attached to the centre of the square perpendicular to its plane (Fig. 126); by plunging this into the pasty mass, and working it up and down, a sufficiently efficient mixing was brought about. Such implements are still in use, especially for small-scale operations, but have been largely superseded by mixing machines, the operation of agitation by their means being still spoken of as "crutching." For inter-mixing silicate or resinate of soda solution with boiled soaps in large quantities at a time, or for otherwise working in saline solutions to dilute and harden the soap or improve its detergent qualities, or "filling" of various kinds, as well as for preventing separation of watery fluid from the mass, such machines are largely employed. Various forms are employed—Fig 127 represents a horizontal cylindrical form, with a rotating internal axle provided with projecting vanes for stirring up the contents; when required for rapid cooling or heating an outer jacket is applied into which water or steam can be admitted as required (Fig. 128).

Figs. 129 and 130 represent a series of three crutching pans arranged so as to be worked from the same shaft. By means of the clutches indicated, any one of the three can be set in motion or stopped as required: the stirring vanes are here horizontal, projecting from a vertical axle, similar fixed vanes being arranged internally so as to prevent the liquid mass from

simply swinging round and round without being broken up and intermixed.

In another form of mixing machine two sets of vanes are

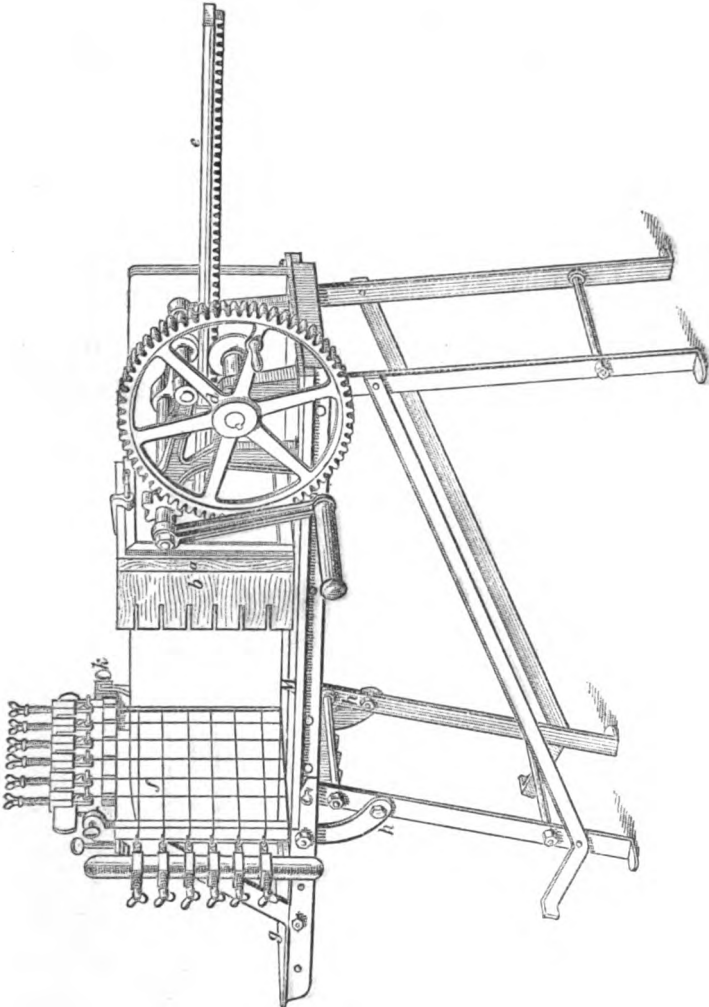

Fig. 124.

provided, moved in opposite directions by means of bevel wheels, one axle being hollow and the other working inside it like the axles carrying the two hands of a watch. The vanes slope at an angle of 45° , so that the material is continually

lifted and the different layers intermixed, the general action resembling that of an ordinary eggwhisk. Large steam driven

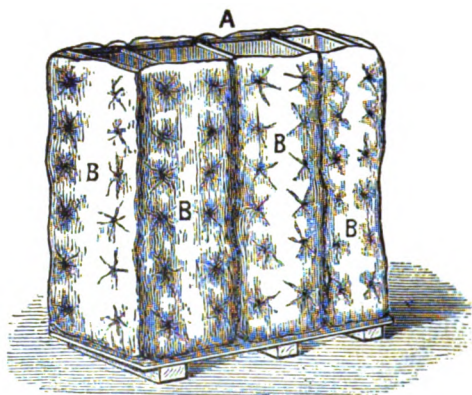

Fig. 125.

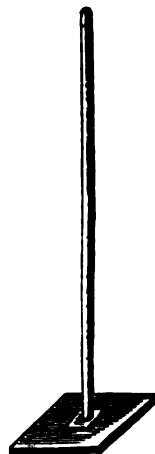

Fig. 126.

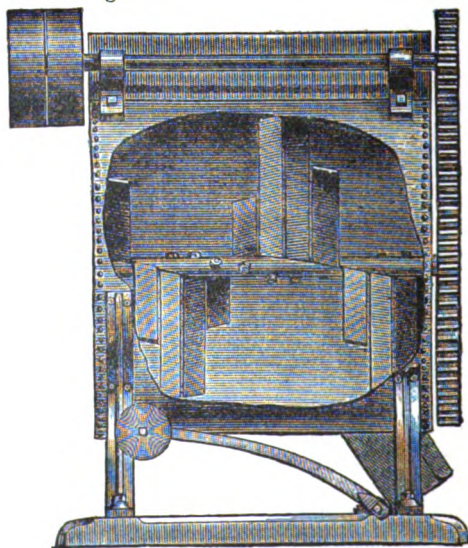

Fig. 127.

sizes are very effective ; but if worked too rapidly the mass is apt to become frothy. For very stiff soap, an archimedean screw, working inside a wider cylinder, answers very well.

Toilet Soap Machinery.—In the manufacture of various kinds of toilet soaps, several special kinds of appliances are used varying in their nature with the process adopted. When “stock” soaps prepared on the large scale are “remelted,” for the purpose of blending together different kinds, with the addition of colouring or scenting materials, &c., a steam jacketted pan is generally preferred, somewhat after the fashion of Fig. 110; as the soap (previously cut up into small lumps) melts, it is mixed together either by hand crutching (*supra*) or by means

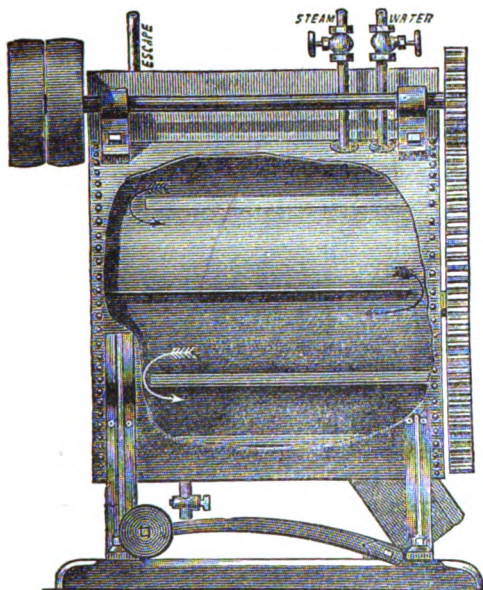

Fig. 128.

of some form of agitator; too rapid a movement must not be communicated to this, otherwise air bubbles are stirred in and the soap becomes more or less frothy, forming a spongy mass when solid.* Figs. 131 and 132 represent a very effective form of remelter constructed by W. Neill & Son, where the heating action of the outer steam jacket is greatly amplified by means of the internal cross steam pipes; the pieces of soap are continually brought in contact with these by the motion of the agitating arms, and as a large heating surface is thus brought into play the remelting proceeds rapidly. When finished, after intermixture of the various ingredients

* “Floating” soaps are purposely prepared in this way, enough air bubbles being worked in to enable the tablet to float in water, even after compression in the stamping press.

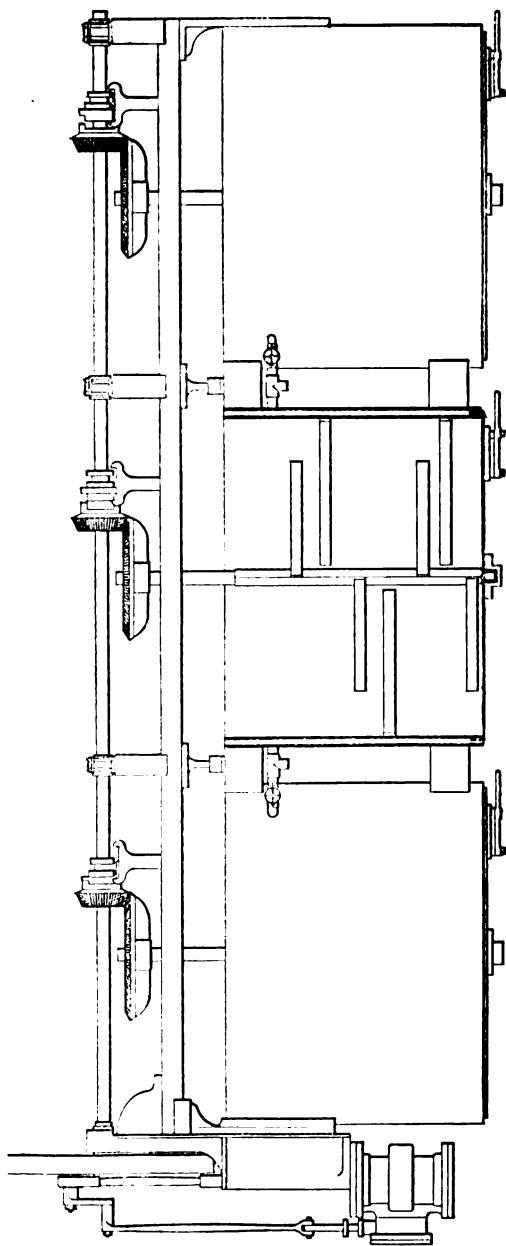
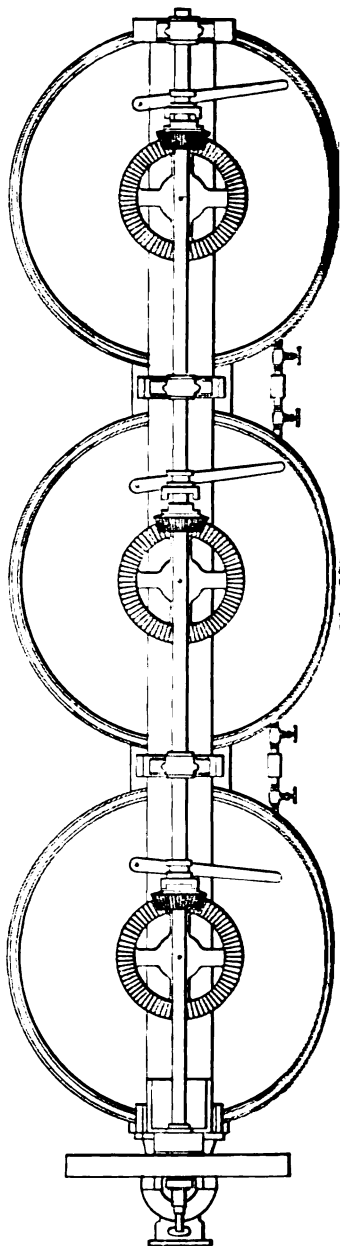

Fig. 129.



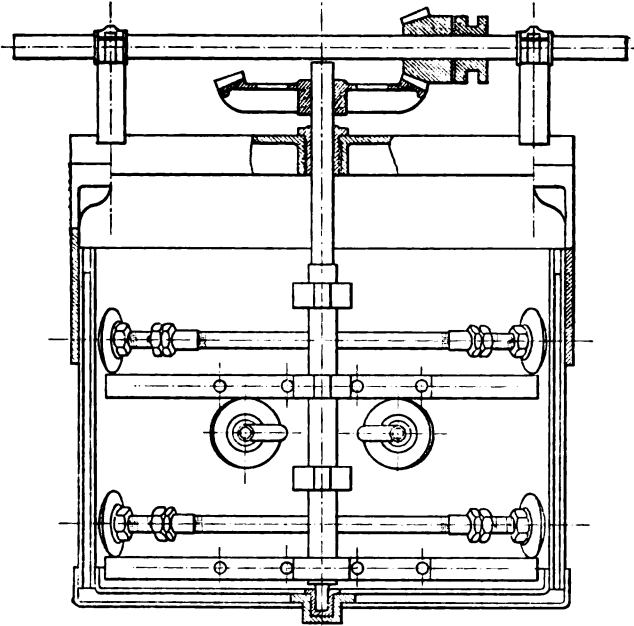

Fig. 131.

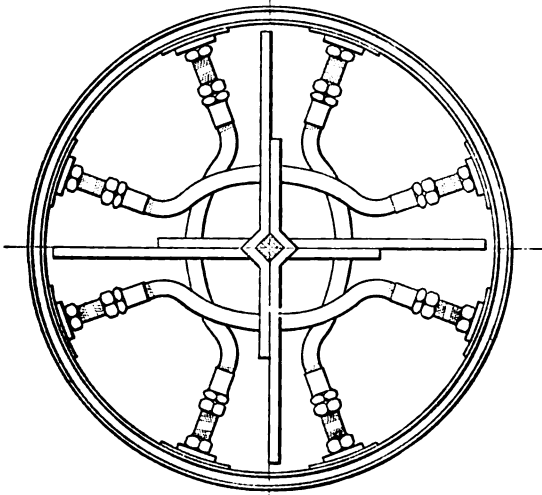

Fig. 132.

intended to render the soap emollient, to scent it, or otherwise to improve its qualities, the fluid mass is cast in small frames so as to form blocks of $\frac{1}{2}$ cwt. or upwards, according to circumstances; usually these are made of iron plates bolted together, as indicated in Fig. 119, so as to cool quickly and avoid as far as possible loss of volatile scented materials, and the injurious effect of heat thereon. The blocks when cold are then slabbed and barred by hand or machine, and the bars cut into short lengths, each of which is then stamped into tablet form by some form of press acting on the principle of a coining press, where

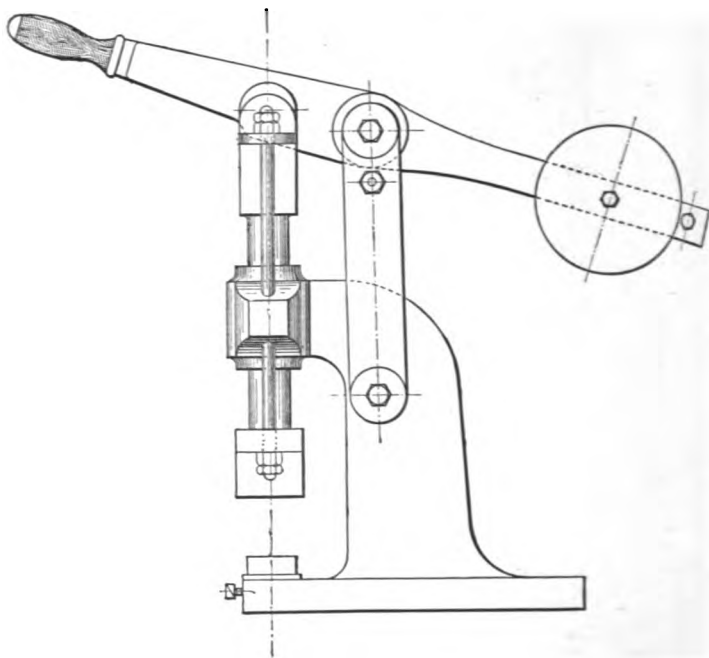

Fig. 133.

both sides of the coin or medal are embossed at once, a ring or collar being adjusted round the medal so as to prevent its swelling out sideways under the pressure. A large variety of tablet stamping machines are in use; some are worked by hand, the upper die and collar being attached to a rod or plunger worked by a lever provided with a balance weight, so that by forcibly pulling down the lever the die descends and stamps the tablet. Fig. 133 represents a machine of this description, and Figs. 134 and 135 a steam stamping machine, where the impact of the die is given by letting steam into the cylinder by means of the valve

handle, so that the piston suddenly rises, and consequently depresses the plunger to which the die is attached on the opposite side of the axis of motion. In another form of machine

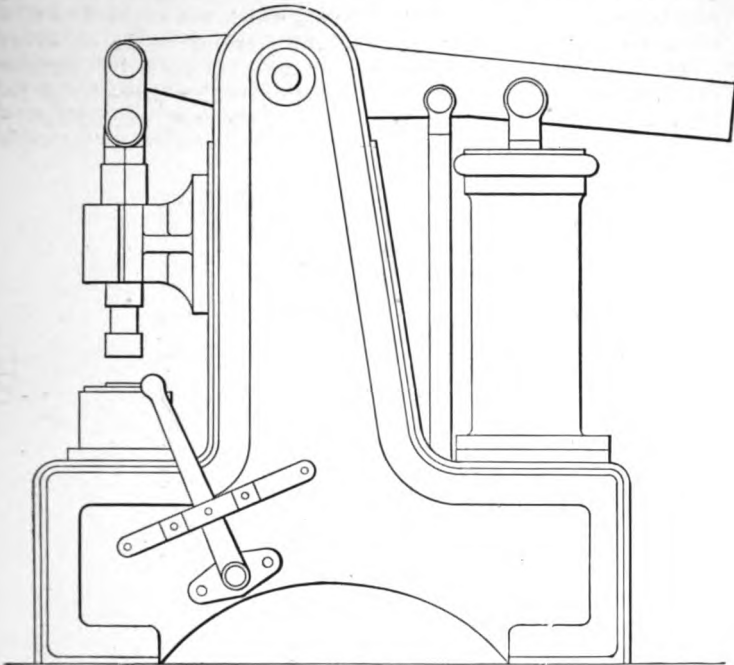

Fig. 134.

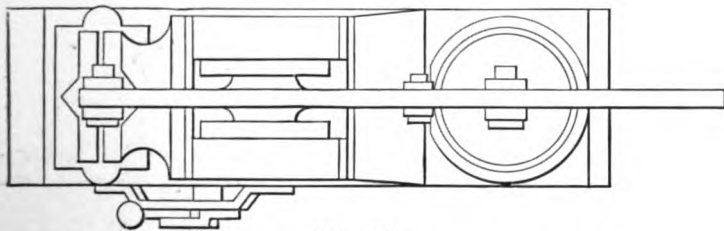

Fig. 135.

the requisite impact is given by raising the upper die to which a considerable weight is attached, and then letting it fall, pile-driver fashion.

In the case of transparent toilet soaps made by the spirit process (Chap. xx.), the pan in which the solution of the soap in

spirit is effected is connected with a still head and worm, so that the alcoholic vapours evolved are condensed and regained. With soaps of this class, the liquid soap left when most of the spirit is distilled off is run into frames, so as to gelatinise and solidify, and is then cut up into tablet blanks, which are exposed to the air for a considerable length of time (several weeks or even months) in a warm room, so as to consolidate them by gradual evaporation of remaining alcohol, &c., otherwise they would be too soft to keep their shape properly. Moreover, when freshly

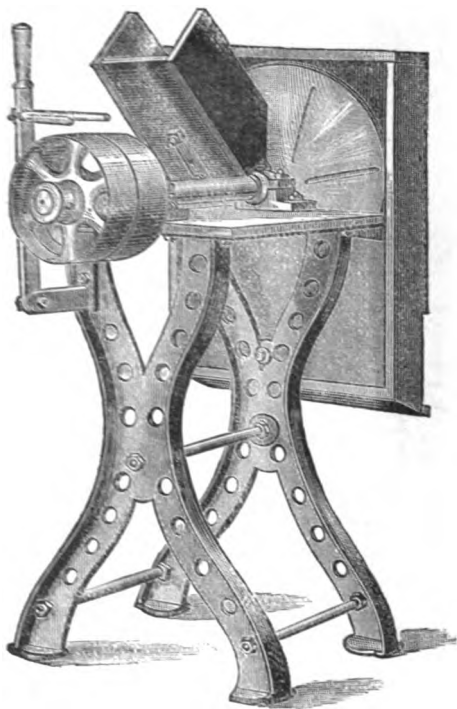

Fig. 136.

prepared the mass is often "muddy;" but on keeping, it gradually becomes transparent and clear.

Milled Soaps.—Much more elaborate machinery is requisite for the manufacture of "milled" soaps. The bars of stock soap are first "stripped"—i.e., cut into slices or chips by a slicing machine, actuated like a rotary plane or vegetable cutter. Fig. 136 represents Rutschmann's stripping machine. The chips are dried in a warm air chamber until only a few per cents. of moisture are retained, and are then ground between successive

pairs of heavy horizontal rollers, so arranged that the soap first passes between No. 1 and No. 2 rollers, then between No. 2 and No. 3, and so on, somewhat as in the case of seed crushing for oil extraction (p. 218). Each roller is made to revolve somewhat faster than the previous one, so that the soap slices are not merely *crushed* in passing through, but are also *rubbed*; the soap always adheres to the more quickly moving roller, so that it passes onwards automatically. By means of "doctors" or scrapers, it is detached from the last roller in strips or ribbons, which are returned to the front of the machine and passed

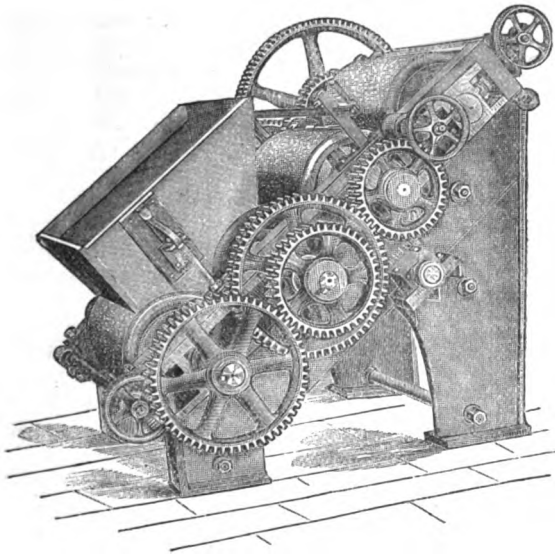

Fig. 137.

through again and again. Fig. 137 represents a form of mill for the purpose.

In order to facilitate the preliminary drying of the stock soap, A. & E. des Cressonnieres* use a series of rollers arranged vertically one above another in an enclosed space heated by steam or hot air, &c. Soap in a just fluid state from the remelter, &c., passes in a flat stream from a hopper on to the top roller, the contact with which partly solidifies it; the resulting semisolid sheet passes alternately from right to left, and *vice versa*, between each successive pair of rollers, as in the mill itself, finally emerging at the bottom in the form of a solid sheet, which is separated by an automatic cutter into strips. The temperature

* English patent, No. 2,446, 1890.

of the chamber and the rate of soap supply are so adjusted that the strips are sufficiently dried by the time they emerge.

When the various stock soaps used, colouring matters, perfumes, unguents (lanolin, vaseline, spermaceti, &c., as required in special cases), or medicinal agents, are thoroughly incorporated together in the mill, the whole mass (if not over-

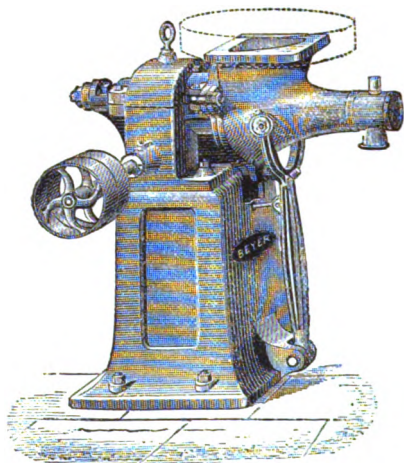

Fig. 138.

dried) becomes comparatively soft and plastic, much as partially dried putty is softened by rolling and working it in the hand. When thoroughly intermixed, the ribbons stripped off the last roller are strongly compressed together; in one class of machine by filling them into a barrel or cylinder provided with a conical end terminating in a nozzle, and forcing the mass outwards by means of a piston worked by a screw or by hydraulic power: the plastic ribbons are thus "squirted" outwards through the nozzle as a continuous bar, which is then cut into short lengths and stamped into tablets. In another class of "plotting machine,"* the ribbons are made to fall from a hopper into the grooves of a large conical archimedean screw working in a funnel shaped barrel, terminating in a nozzle of appropriate size; as the screw revolves the soap is gradually propelled onwards towards the nozzle, and on account of the diminishing diameter of the worm, becomes strongly compressed together, so as finally to issue from the nozzle as a firm solid bar, which is then cut up and stamped as before. Fig. 138 represents Beyer's plotting machine working on this principle.

Cylindrical and spherical soap tablets and wash balls are sometimes prepared; these are usually stamped into approximately the required shape by means of suitable presses, or by hand, and when sufficiently dry, finished by turning and polishing in a kind of lathe.

In order to give a polished surface to soap tablets, a method frequently employed is to expose them to wet steam for a few seconds, which glazes the exterior. More expensive varieties are sometimes polished by hand, using a cloth dipped in alcohol, &c.

* From the French term, "*pelotage*," applied to this squirting process.

CHAPTER XX.

MANUFACTURE OF SOAP.

As compared with metallurgical and textile industries the art of soapmaking is not possessed of any claims to great antiquity; the ancients were acquainted with the detergent power of wood ashes (vegetable alkali) and probably also with that of mineral soda or *natron*,* but do not appear to have known anything of the products of the action of these substances on oleaginous materials, no mention of any such compounds being to be found in Homer or other early Grecian authors; whilst the Hebrew term *borith* † used by the prophets Jeremiah and Malachi, although translated “soap,” appears to have simply meant *wood-ash alkali*.

Pliny the elder, however, in the first century A.D. described a sort of imperfect soft soap made from goat's tallow and the alkali from beechwood ash; and also a harder variety (possibly got by the action of salt on the former, producing soda soap); and another writer in the second century in a work entitled *De Simplicibus Medicaminibus* refers to a softer “German” variety of soap (probably chiefly made from the ashes of land plants) and a harder “Gallic” form (probably derived from seaweed ash). Later still, soapmaking appears to have been somewhat more extensively practised, as the remains of a soap factory have been found at Pompeii.

Soapmaking Processes.—The variations in the different methods by which soaps are prepared on the manufacturing scale are somewhat numerous, but all may be conveniently classified under one or other of the three following heads, so far as the essential parts of the soap producing processes are concerned. In many cases, however, various subsequent operations are gone through before the goods are finally ready for the market, consisting either of mechanical cutting and shaping operations, such as casting into blocks, cutting these up into slabs, bars, and tablets, and stamping the latter into shape in appropriate presses; or of the addition of other substances to the soap before cooling

* Proverbs xxv. 20.—“As vinegar upon nitre [*or soda*, marginal note, Revised Version], so is he that singeth songs to an heavy heart.” The frothy non-permanent effervescence due to the action of the acid on *natron* is doubtless what is here alluded to; acetic acid and *nitre* (potassium nitrate) having no mutual action whatever.

† Jeremiah ii. 22.—“Wash thee with lye, and take thee much soap.” Malachi iii. 2.—“Like a refiner's fire and like fuller's soap.”

or solidifying, so as to increase its detergent properties; or to give it special qualities (*e.g.*, disinfecting action); or to harden it, so as to enable more water or other weight-giving "filling" to be added without rendering it too soft for ordinary scouring purposes, &c.

I. Direct Neutralisation Processes.—Where free fatty acids and alkalis are brought together and converted into soaps by directly neutralising one another, with or without evolution of carbonic acid gas according as carbonated or caustic alkalis are employed. Obviously no glycerol is produced in the formation of soaps of this kind.

The free fatty acids thus employed are practically almost confined to the "red oils" of the candlemaker (p. 386)—*i.e.*, the liquid fatty acids expressed from the mixed products of saponification leaving behind the solid acids (commercial "stearine"). Certain distilled and recovered greases (such as Yorkshire grease from the suds of wool scouring, &c., Chap. XII.) are of similar character, and are sometimes intermixed with red oils for the purpose of soapmaking in this way; but, as a rule, they are not suitable alone for the preparation of soap of good quality. Resinate of soda (rosin dissolved in soda ley) used in the manufacture of rosin soaps (*infra*) is a product of precisely similar nature, excepting that the rosin acids do not belong to the ordinary fatty acid families described in Chap. III.

II. Soapmaking Processes where Glycerol is set free but not separated from the resulting Soap.—In these processes natural glycerides are employed, being acted upon by alkalis (usually caustic) used in regulated quantity so as to suffice to saponify the total fatty matters without introducing any large excess of alkali; the strength of the ley being made such that the product becomes more or less solid after cooling and standing, the glycerol consequently being contained in the product.

To this class belong more particularly *soft soaps* made by boiling together appropriate oils, &c., and potash; *marine soaps* and *hydrated soaps* prepared in similar fashion, mostly with soda and largely from cokernut or palmtree oil; so-called *cold process* soaps of various kinds, more especially certain forms of transparent soaps, perfumer's soaps, and analogous products; and certain kinds of soap prepared under pressure.

III. Soapmaking Processes where the Glycerol set free and the resulting Soap are separated from one another.—In these processes the essential feature is that glycerides are more or less completely saponified by boiling up with comparatively weak alkaline leys, and the soap formed "salted out" by addition of brine or solid salt so as to separate it as a pasty mass from the watery fluid in which the glycerol remains dissolved. The half made soap thus obtained is then finished by one or

other of various processes, leading to the production of some variety of "curd," "mottled," or "fitted soap;" whilst the watery liquors are either thrown away or utilised by boiling down so as to recover more or less of the dissolved salt for use over again, and ultimately obtain the glycerol in an impure form (*vide* Chap. XXII.) As regards the magnitude of the scale on which they are made, and the total quantity manufactured, boiled soaps of this class are the most important of all. Additional materials are frequently added to the soap thus prepared for special purposes—*e.g.*, silicate of soda, borax, and aluminate of soda, to increase the detergent action of household and laundry scouring soaps; sulphate and carbonate of soda, to stiffen and harden the soap, and prevent it from wasting too rapidly in use; resinate of soda, in the manufacture of yellow soaps; carbolic acid, creosote oils, and similar substances, in the manufacture of disinfecting soaps; and so on. When potassium carbonate is thus added to molten soda soap in not too large a quantity double decomposition takes place between the sodium salts of the fatty acids and the potassium carbonate; thus in the case of stearate—

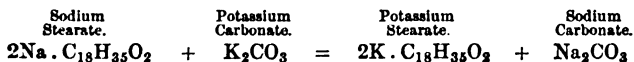

The result of this is accordingly the formation of a certain proportion of comparatively soft potash soap instead of the harder soda soap, which alters the texture of the mass; this operation of "pearlashing" is consequently employed in the preparation of certain kinds of toilet soaps (*infra*). On the other hand, if fatty matters be saponified with boiling potash ley, and the resulting soap salted out with ordinary salt, the opposite kind of change takes place, soda soap and potassium chloride being formed—*e.g.*, in the case of palmitate—

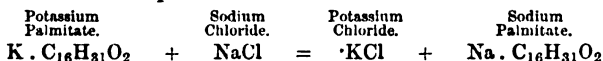

In the earlier days of soapmaking, when woodash was the most available form of alkali, this reaction was of some technical importance as enabling a hard soda soap to be obtained in lieu of a soft greasy product; but although the effect appears to have been known and the operation practised to some considerable extent, it is doubtful if the chemical nature of the change was understood until recently (*vide* Chap. XXI.)

DIRECT NEUTRALISATION PROCESSES.

The preparation of soap by the direct combination of free fatty acids and alkalis is an extremely simple operation, more especially when the alkali is caustic; all that is required is a suitable mixing pan provided with an agitator so that the fluid ingredients

can be intimately intermixed. Fig. 139 represents a steam jacketted pan with steam pipes, *ppp*, projecting upwards into the pan, whilst an agitator, *e*, worked by bevel wheels, carries a series of vertical vanes projecting downwards, so that clots are broken up by the interlacing of the pipes and vanes. Another form of agitator consists of two sets of rods or vanes made to revolve in opposite directions by means of bevel wheels. The red oils, &c., are run into the pan (steam jacketted for large operations) and heated up; the alkaline ley is gradually run in

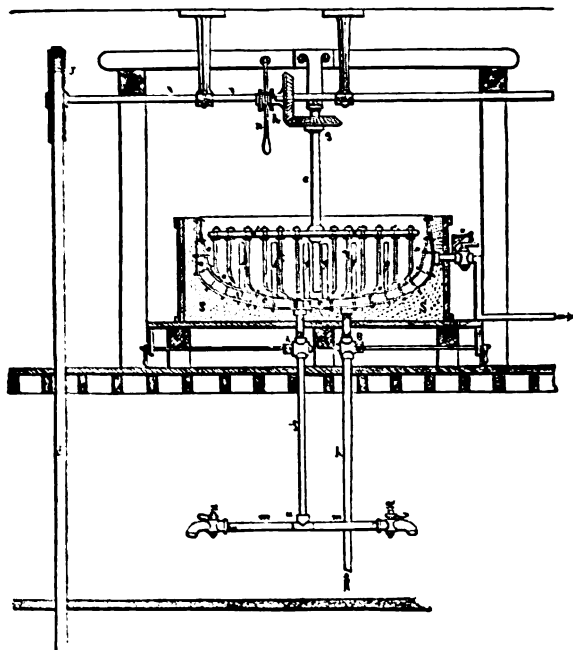

Fig. 139.

with agitation, and finally the hot pasty mass transferred to a "frame" in which it solidifies to a block of soap.

A slight surplus of alkali is practically imperative in order to ensure complete conversion of the fatty acid into soap; this surplus mostly remains disseminated through the mass as it solidifies, although a small quantity generally exudes as a watery fluid; by carefully regulating the quantities used the excess may when requisite be diminished considerably below that indicated in the example given below, where 5 parts of free alkali are reckoned for 40 combined, representing a ratio of 1 to 8

or 12.5 to 100. On the other hand, for soaps intended to be highly detergent a larger excess of alkali is intentionally used.

Carbonated alkali is sometimes used, instead of caustic, in the preparation of "oleine soap" (Morfit's process); of late years, however, the facilities for obtaining solid caustic soda as a commercial product have increased so largely that the slight saving in cost effected by the use of the former is generally considered to be more than outweighed by the increased amount of trouble involved in the process. When employed, the mixing pan is fitted with a large movable "curb" (a funnel or barrel shaped top—Fig. 113) in which the froth rises, due to the liberation of carbonic acid, and the operation is carried out somewhat more slowly to avoid frothing over.

With inferior soaps, largely made from recovered greases and such like materials, silicate of soda is sometimes mixed or "crutched" into the mass when the combination is complete, just before running into the frames. For this purpose crutching machines, such as those represented by Figs. 127 to 130, are conveniently used. Resinate of soda is also employed as an ingredient to increase the detergent action. On the other hand, with soaps required to contain as little free alkali as possible, not only is great care taken to reduce the proportion of free alkali present to the minimum consistent with proper combination of the fatty acids, but in special cases—*e.g.*, for wool-scouring soaps and soaps used in the silk industries, further means are adopted to render the small excess innocuous. One method, found in practice to be very effective (patented by the author), consists of the addition of a regulated quantity of an ammoniacal salt (usually dissolved in a minimum of water) to the pasty mass, and well incorporating by a crutching machine or otherwise before running into the frame. Any free alkali is thus neutralised by the acid contained in the ammoniacal salt, with the formation of an equivalent amount of free ammonia. This latter mostly escapes when the soap is cut into bars and stored, but the little that remains is beneficial rather than injurious to wool and silk, unlike the original free fixed alkali.

Resinate of soda is often prepared for intermixture with soaps of various kinds by boiling up rosin with rather less than twice its weight of soda ley of about 16° T. (specific gravity 1.08), containing about 7 per cent. of NaOH* until completely dissolved. The liquid sets to a sort of thin jelly when cold, containing the soda salts of the rosin acids and more or less excess of alkali, according to the quantity used. Any kind of pan will answer if furnished with a wet steam coil, or with an agitator and some other suitable means of heating. Morfit's steam twirl (Fig. 111, p. 429) answers well.

* The saponification equivalent of rosin usually lies between 330 and 370, so that 100 parts of rosin correspond with between 10.8 and 12.1 parts of NaOH.

Calculation of Quantity and Strength of Ley required, and of Composition of resulting Soap.—The quantity of ley of a given strength employed depends partly on the mean equivalent of the oleine, &c., used, and partly on the amount of excess of alkali intended to be added to ensure complete neutralisation and communicate extra detergent properties to the soap; whilst the exact strength employed depends on the proportion of water the finished soap is intended to contain. Assuming the oleine to be pure oleic acid, its saponification equivalent would be 282—i.e., 282 parts of oleine would neutralise 40 of NaOH in accordance with the reaction.

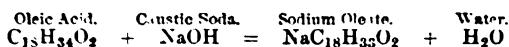

Supposing the ley to be a pure solution of sodium hydroxide, if such a quantity were used as would contain 45 parts of NaOH, 5 would consequently remain unneutralised, or the "free alkali" would bear to the "combined alkali" the ratio 5 to 40 = 1 to 8 = 12.5 per cent.; if, then, 140 parts of ley were used, containing 45 of NaOH (32.1 per cent.), neglecting mechanical losses and evaporation, the resulting mass would consist of 282 + 140 = 422 parts, made up thus—

Sodium oleate,	304 parts	=	72.04 per cent.
Excess of caustic soda,	5 "	=	1.18 "
Water,	113 "	=	26.78 "
	422		100.00

The 113 parts of water are made up of 140 - 45 = 95 parts contained in the ley used, and 18 parts formed by the above reaction.

If a proportionately larger amount of weaker ley were used containing 45 parts of NaOH in 160 (28.1 per cent. of NaOH) the resulting mass would consist of 282 + 160 = 442 parts, made up thus—

Sodium oleate,	304 parts	=	68.78 per cent.
Excess of caustic soda,	5 "	=	1.13 "
Water,	133 "	=	30.09 "
	442		100.00

On the other hand, if a proportionately less amount of stronger ley were used containing 45 parts of NaOH in 120 (37.5 per cent. of NaOH) the composition of the resulting 282 + 120 = 402 parts would be—

Sodium oleate,	304 parts	=	75.62 per cent.
Excess of alkali,	5 "	=	1.24 "
Water,	93 "	=	23.14 "
	402		100.00

In similar fashion the strength and quantity of ley requisite for any other given mixtures of free fatty acids can be calculated; thus suppose the mean equivalent of the fatty acids to be E , and that the surplus free alkali is to be n per cent. of that combined as soap; then for E parts of fatty acid a quantity of ley must be used containing $40 \times \frac{100 + n}{100} = 0.4 \times (100 + n)$ parts of NaOH altogether. With a ley containing saline matters (chloride, sulphate, &c.) representing m parts per 100 of NaOH, the quantity of saline matter will be $\frac{m}{100} \times 0.4 \times (100 + n) = 0.004 \times m \times (100 + n)$; so that a weight, W , of ley will contain—

NaOH,	0.4 × (100 + n)
Saline matters,	$m \times 0.004 \times (100 + n)$
Water,	$W - 0.004 \times (100 + m) (100 + n)$

Hence the total water present will be—

$$18 + W - 0.004 \times (100 + m) (100 + n),$$

and the resulting soap will consist of—

Sodium oleate,	E + 40 - 18	= E + 22
Excess of NaOH,	$\frac{n}{100} \times 40$	= 0.4 × n
Saline matters,	$\frac{m}{100} \times 0.4 \times (100 + n)$.	= 0.004 × m × (100 + n)
Water,	<u>W + 18 - 0.004 (100 + m) (100 + n)</u>	
Total,	E + W.

Suppose that w parts of resinates of soda solution be added to the soap, consisting of—

Resinate of soda,	a parts.
Excess of NaOH,	b ,,
Water,	$w - (a + b)$,,

then the total mass, neglecting mechanical loss and evaporation, will consist of—

Soap (sodium oleate + resinates),	E + a + 22	
Excess of NaOH,	0.4 × n + b	
Saline matters,	0.004 × m × (100 + n)	
Water, W + w + 18 - {	<u>0.004 (100 + m) (100 + n) + a + b}</u>	
Total,	E + W + w.

If, on the other hand, w' parts of silicate of soda be added, containing—

Silicate of soda and other saline matters,	c parts.
Excess of NaOH,	d ,,
Water,	$w' - (c + d)$,,

then the total mass will contain—

Sodium oleate,	$E + 22$
Excess of NaOH,	$0.4 \times n + d$
Sodium silicate and other saline matters,	$0.004 \times m(100 + n) + c$
Water,	$W + w' + 18 - \{0.004 \{100 - m\} (100 - n) + c + d\}$
Total,	$E + W + w'$

These various quantities are readily calculated into percentages when the values of $E, m, n, a, b, c, d, W, w, w'$ are given for any particular case—*e.g.*, suppose $E = 280, n = 10, m = 12$, and $W = 150$ in the case of a soap not treated with resinate or silicate, &c., then the composition is—

Sodium oleate,	$250 + 22 = 302.0$	$= 70.23$	per cent.
Excess of NaOH,	$0.4 \times 10 = 4.0$	$= 0.93$	„
Saline matters,	$0.004 \times 12 \times 110 = 5.28$	$= 1.23$	„
Water,	$150 + 18 - 0.004 \times 112 \times 110 = 118.72$	$= 27.61$	„
Total,	$280 + 150 = 430.00$	$= 100.00$	„

and similarly in other cases.

SOAPMAKING PROCESSES WHERE THE GLYCEROL IS SET FREE BUT NOT SEPARATED.

The methods of this character may be divided into three classes according to the temperature and pressure employed. In so-called “cold process” soaps the materials to be saponified and the alkaline ley are intimately intermixed in open vessels at temperatures usually considerably below the boiling point, and allowed to stand until the action is complete, the leys used being of sufficient strength to yield a product not too moist. “Hydrated” soaps (including “marine” soap) and “soft” soaps are prepared by boiling together the materials under the ordinary pressure; whilst soaps prepared under increased pressure are treated in closed vessels so as to obtain a still higher temperature for the purpose of shortening the operations and rendering them more complete. In all cases the amount of alkali employed must be carefully proportioned to the quantity of fatty matters used and their mean saponification equivalent, otherwise either an imperfect soap will result containing more or less unaltered grease owing to the use of a deficiency of alkali, or a strongly alkaline one through the use of too great an excess. Sometimes these two faults occur simultaneously through the action not having been completely carried through; this is not unfrequently the case with soaps made on the small scale with highly scented materials (perfumer's soap), where avoidance of much rise of temperature is indispensable, since otherwise the delicacy of the odour would be deteriorated, so that the product is apt to contain

simultaneously unaltered fatty glycerides and uncombined caustic alkali. Soaps of this kind, however, have now been largely driven out of the market by "milled" toilet soaps where the evil effect of heat on delicate perfumes is avoided, and at the same time a perfectly made soap ensured, by mixing a good kind of stock soap with the scented materials, &c., by machinery, grinding them together in the cold (*vide infra*, also p. 446).

Cold Process Soaps.—For the preparation of cold process soaps on the large scale a "Hawes' boiler" is convenient. The fatty matters (tallow, either alone or mixed with palm oil or lard, and preferably a small quantity of cokernut oil, the presence of which facilitates the saponification; or other similar mixtures) are introduced into a pan such as that indicated in Fig. 140, or into a horizontal cylinder, Fig. 141 (5 to 6 feet diameter), provided

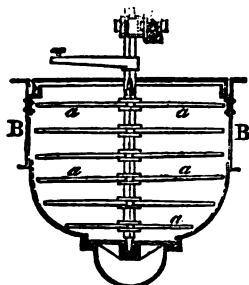

Fig. 140.

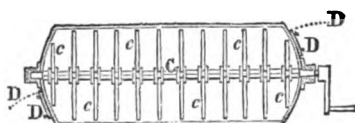

Fig. 141.

with a mechanical agitator and heated till sufficiently fluid, usually to about 45° C. (about 113° F.) Strong soda ley of about specific gravity 1.33 (66° Twaddell, containing about 24 per cent. of NaOH) is then run in in sufficient quantity (approximately two parts of fat to one of ley, the exact proportion varying with the mean saponification equivalent of the fatty matters), with continuous agitation until the whole becomes pasty and thoroughly intermixed; the paste is then run out into a wooden frame and well covered up to keep in the heat; as warmth is produced by the saponification change, the mass does not cool until the action is completed; at first the change takes place only languidly, but after a while it becomes more rapid and the mass sensibly heats; by and bye as the action approaches completion the temperature begins to fall again. If the materials are too highly heated at first the paste is apt to be too fluid, so that unsaponified grease and watery ley tend to separate partially during the period of standing, thus yielding an imperfect product. Instead of soda alone a mixture of soda and potash (the former largely predominating) is often employed with the object of obtaining a product of superior texture.

Certain kinds of transparent soaps (often termed "glycerine soaps") are frequently prepared by means of a modification of the cold process; the warm fatty materials employed (of which castor oil is generally a considerable ingredient on account of its ready saponifiability and its tendency to form translucent soaps) are intimately intermixed with soda ley (and in certain cases a small proportion of alcohol); soluble colouring matters and essential oils and other scents are then stirred in and the whole allowed to stand until saponification is complete: with suitably chosen ingredients and proportions the resulting block of soap is more or less transparent, the presence of the glycerol formed on saponification tending to cause the soap to assume a "colloid" or gum-like structure instead of the semicrystalline opaque condition usually developed in ordinary hard soaps. When alcohol is not used as an ingredient in the mass, the transparency is usually only imperfect, but by incorporating extra glycerol instead a highly transparent mass can be readily obtained. Cane sugar effects the same result, and is generally employed instead of either alcohol or glycerol on account of its cheapness; but the effect on the nature of the resulting product is by no means the same, inasmuch as saccharine substances are apt to produce a very unpleasant irritating effect when applied to highly sensitive skins (ladies', babies', invalids', and so forth). This, moreover, is apt to be greatly aggravated by the presence of a more or less considerable excess of alkali in the soap mass, necessarily added to effect complete saponification,* inasmuch as muddiness is apt to be produced if any of the fatty glycerides remain unchanged, which is likely to be the case, unless some excess of caustic alkali is present. It accordingly results that many kinds of transparent so-called "glycerine soaps" are of the worst possible quality from the point of view of liability to excoriate and irritate extremely tender skins; although their appearance, when attractively tinted and agreeably scented, render them apparently very elegant articles.

The cheaper kinds of transparent soap of this description are often extensively "filled in" with liquid paraffin and petroleum hydrocarbons which possess the property of blending with the sugary soap mass without seriously interfering with either its consistency or transparency; taking into account some 20 to 25 per cent. of "loading" thus introduced, together with some 12 to 18 per cent. of sugar, and 20 to 25 per cent. at least of water, it often results that the actual soap present does not exceed 33 to 40 per cent. of the mass. On the other hand, a well made soap where the minimum possible excess of alkali only has been used, where the rate of saponification and ten-

* Transparent soaps made by the "spirit process" (*infra*) are generally free from this defect, although as usually sent into the market they contain considerable amounts of cane sugar.

dency to colloidal structure of the product have been intensified by the use of an admixture of spirit in the original materials, together with a little glycerol instead of sugar, and where no loading has been added, not only contains a far larger proportion of useful ingredients of much better quality, but also for that very reason resists the wasting and solvent action of water (especially when hot) much more completely, and is consequently much more economical in use, as well as comparatively free from corrosive action on delicate skins.

Soft Soaps.—Potash soaps appear to possess, on the whole, a greater tendency to assume the colloid form than soda soaps, in consequence of which, when prepared from suitable fatty matters, they are more inclined to be jelly-like and transparent or translucent, than to form comparatively hard opaque semicrystalline masses like ordinary soda soaps; moreover, they are generally deliquescent, so that they do not readily dry up. The precise texture of a given mass, however, largely depends on the temperature, as in cold weather crystalline grains often form, more especially when the fatty matters used contain palmitic or stearic acid: soap exhibiting this peculiarity (known as “figging”) is generally supposed to be of superior quality for that reason, although on what grounds it is difficult to say; the granular appearance is sometimes imitated by mixing in starch, clay, steatite, &c. Linseed and other drying oils (poppy seed, hempseed, &c.); non-drying and semidrying vegetable oils (such as rape, camelina, and cotton seed) and similar animal oils (train, liver, and fish oils); together with the “red oils” of the candlemaker (crude oleic acid), are those most largely employed in the manufacture of soft soaps, a little tallow being added to furnish stearate for “figging,” and in many cases indigo in small quantity so as to give a greenish shade (by conjunction with the yellow tinge of the untinted soap); this tint being natural to hemp seed oil, and, therefore, artificially imitated in other cases. When whale and fish oils are employed an unpleasant smell is apt to be communicated to linen, &c., washed with such soap. Considerable practice and skill is requisite in boiling soft soap, although the actual operations are of the simplest character; the “copper” or pan (usually made of iron plates rivetted together boiler-fashion—Fig. 112) in which the boiling takes place was formerly mounted over a free fire, but is now generally heated by means of two steam coils, one for “dry steam” (*i.e.*, simply a coil through which superheated steam circulates so as to heat up the contents of the pan), the other for “wet steam” (*i.e.*, a coil perforated with holes, so that when steam is let in from the boiler it escapes into the mass through the holes, heating it up and becoming itself condensed, until the temperature is so high that the steam simply blows through). Figs. 114, 115 illustrate a pan fitted with the two kinds of steam coils. The mixed fatty matters are run into the

copper so as to fill it to about one-fifth or one-fourth of its capacity; the whole is then heated up (by free fire when that is used, by means of the dry steam coil if no free fire is employed), and whilst heating potash ley (usually of specific gravity 1.07 to 1.08) is slowly run in. This ley is found by experience to act better if not completely causticised, a portion (some 15 to 25 per cent.) of the alkali being still carbonated;* the heat should be so applied, and the rate of supply of ley so adjusted, that by the time that a volume of liquor about equal to that of the oil has been run in, the whole mass is beginning to boil; to prevent frothing over a "fan" (Fig. 116) is conveniently arranged over the pan. The boiling is continued with wet or dry steam, usually the former, with further additions of ley from time to time, until the proper consistency and appearance are arrived at as judged by taking out samples and quickly chilling them; as long as an insufficient quantity of ley has been used a visible appearance of unsaponified fat is manifest, giving a peculiar border to the sample; whilst if excess has been added the sample more or less tends to separate into two different portions, one of soap, the other of watery liquor; in this case more oil (agitated and emulsified with a little weak liquor to enable it to mix better with the boiling mass) is added, and so on until the sample sets to a clear translucent mass. Finally the wet steam is shut off and the mass boiled either by dry steam or free fire until sufficiently concentrated by evaporation, when the finished soap is barrelled or put up in canisters or drums for sale.

Some makers prefer to use stronger leys in the first instance (specific gravity 1.120 to 1.150 = 24° to 30° Tw.), whereby less boiling down is requisite in the final stage. In some cases a mixture of potash and soda leys is employed, the former, however, always constituting more than half of the total alkali (60 to 75 per cent.) Soft soap containing soda is apt to become muddy in cold weather, and hence is preferably made only in summer.

The exact nature of the mixture of fatty matters employed is generally regarded as a valuable trade secret; the relative proportions of the constituents are often varied somewhat according to the season; in winter the consistency of the product is usually much greater than in summer, so that in the former case, such a mixture is employed as would (for the same atmospheric temperature) give a softer jelly, and *vice versa*. For household soft soaps, silicate of soda (or potash) is sometimes mixed in with the finished soap, whilst rosin is often added to the fatty mixture employed as basis; when the soap is intended for silk and wool scouring, however, such admixtures are highly

* When the soft soap is required to be as nearly neutral as possible, carbonated alkali is undesirable as tending to give a product containing a larger amount of "free alkali" than that obtainable by the judicious use of caustic alkali free from carbonate.

injurious, partly because of the presence of silicated alkali in the soap, which has a very bad effect on the fibre; partly because soaps thus treated usually contain a larger proportion of uncombined potash or soda, or both, than genuine well made soft soap. It is generally supposed that because ordinary woolgrease (suint) naturally contains much potash and but little soda, therefore soda has a more injurious action on wool fibre than potash. Apart from the somewhat illogical character of this reasoning, however, there does not seem to be any experimental evidence extant to show that this is really the case; on the contrary, experience seems rather to indicate that, provided a soap is sensibly *neutral* (*i.e.*, devoid of alkali uncombined with fatty acids), it is but of little consequence whether it be a potash soap or a soda soap as regards injury to the fibre of wool during use in scouring; on the other hand, a highly alkaline potash soap, otherwise pure, exerts more deleterious action than a comparatively neutral soda soap; although, without doubt an alkaline soda soap, especially if silicated, is extremely objectionable. Probably the prejudice respecting the superiority of potash over soda soaps for wool scouring is largely due to the inferiority of the soda (silicated) soaps now manufactured in great quantity for household scouring purposes, when compared with potash soft soaps of good quality as regards the amount and nature of the alkaline constituents present other than true soaps—*i.e.*, compounds with fatty acids; for a well made soda (oleine) soap devoid of silicate or other forms of “free alkali,” such as the dealcalised soap described on p. 453, appears to be in practice quite as well suited for wool scouring purposes as the best potash soft soap obtainable.

Hydrated Soaps.—The term “hydrated soap” is often applied to soap manufactured in much the same way as soft soap, but made with soda as alkali, and with fatty matters of such nature as to furnish a comparatively hard opaque product rather than a soft jellylike mass.* Cokernut or palm kernel oil is generally an ingredient in the mixture of fatty matters used, its presence facilitating the saponification of other fats less readily attacked by alkalies; when this substance constitutes the great majority or the whole of the mass, the product is known as *marine soap*, as the solubility in brine of the soda salts formed from cokernut oil is sufficient to enable it to form a lather with seawater.

Marine Soap.—This is readily prepared by boiling up together with wet steam cokernut or palm kernel oil, and strong soda ley of specific gravity about 1.15 to 1.175 (30° to 50° Tw.), the latter

* In Germany, soap of similar character is often designated *eschweiger zeife*; in America, the term “Swiss soap” is similarly applied. Soaps of this kind are often intermixed with boiled soaps containing no glycerol, so as to form products of mixed character.

being run in slowly. Saponification proceeds very rapidly when once commenced, the mass frothing up largely, and requiring a large pan and curb to avoid loss by boiling over. A boiling temperature, in fact, is not absolutely necessary, nor even desirable to begin with, as the heat liberated by the action rapidly raises the temperature, whence the copious frothing. Owing to the low saponification equivalent of cokernut oil (about 210 to 215), a much larger quantity of alkali is requisite to bring about complete saponification than is the case with most other kinds of fatty matter; 100 parts of cokernut oil correspond with about 19 of NaOH, whereas 100 parts of tallow represent only about 14 parts of NaOH (*vide infra*). A considerable quantity of silicate of soda is generally run into the finished mass and well "crutched in" (*i.e.*, intermixed by agitation); the effect of this is greatly to intensify the natural tendency of cokernut oil soap to form a tolerably solid mass, even when incorporated with a considerable amount of water; so that silicated marine soap often contains less than 20 per cent. of actual soap (sodium salts of fatty acids), and upwards of 70 per cent. of water. Such a soap, when heated alone, generally separates into two distinct substances, *viz.*, a watery solution of silicate, &c., and a pasty mass of actual soap. On account of this tendency to separation, the crutching of the original mass must be prolonged until solidification is tolerably far advanced, in order to ensure a uniform product. As a general rule, the price at which such highly watered soap is sold is not reduced to anything like the extent that would correspond with the amount of water added.

Hydrated soaps made from mixtures containing palm oil, tallow, bone fat, horse grease, &c., are sometimes silicated, but are more frequently hardened by crutching in a strong solution of sodium carbonate (sometimes together with sodium sulphate), whereby not only extra detergent quality is communicated, but also a greater degree of firmness, enabling a larger proportion of water to be present without rendering the soap too soft for sale; the term "hydrated" (or "watered"), indeed, is originally derived from the circumstance that the method of manufacture enables a product to be obtained containing a much larger proportion of water, and a correspondingly less quantity of actual soap, than was formerly practicable with "boiled soaps" of the third class. Even with these, however, it has been found possible to produce an analogous result by somewhat similar devices, more especially by cautiously crutching in saline solutions (sodium silicate, carbonate, &c.) whilst cooling and solidifying (*vide infra*).

Hydrated Soaps prepared under Pressure. — A large number of patents have been taken out from time to time for various processes and modifications of plant, intended to shorten and simplify the manufacture of hydrated soaps by causing the

reaction to occur at a more elevated temperature under increased pressure. Thus Tilghmann proposed the use for soapmaking of the same plant as used by him for hydrolysing glycerides by water alone (p. 385). The apparatus that has been generally found to answer best is some kind of autoclave where the mutually adjusted quantities of fatty matter and lye are either run in through a manhole or pumped in through a pipe, and then heated up either by means of a free fire or by blowing in high-pressure steam, much as in the manufacture of "stearine" for candlemaking (p.

373). Fig. 142 illustrates Dunn's plant, consisting of a vertical boiler, B, with manhole and safety valve; the fat and ley are pumped in through the safety pipe, A, and the finished mass ejected through the emptying tube and cock, C. Heat is communicated by means of free firing, the temperature attained being determined by means of a long-stemmed thermo-

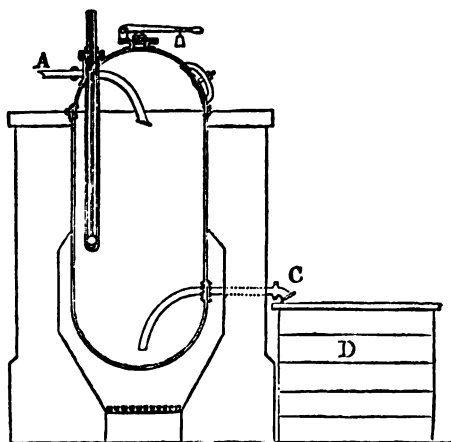

Fig. 142.

meter, inserted in a tube filled with mercury or paraffin wax, projecting inwards into the boiler.*

In Bennett and Gibb's process a horizontal boiler furnished with an agitator is employed, somewhat similar to that used by Howe's (p. 457); into this are continuously pumped at one end the fatty matters to be saponified and soda leys *not causticised* (sodium carbonate solution), containing the appropriate quantity of alkali (30 to 33 parts of soda ash at 48 per cent. Na_2O dissolved in 100 of water to 100 of fatty matter). At the other end the finished soap mass emerges through a weighted exit valve, the pressure being maintained at 220 to 280 lbs. per square inch (about 15 to 20 atmospheres, corresponding with a

* This boiler also serves for the preparation of silicate of soda (or potash) solution. The boiler is charged with broken up flints or quartz pebbles and soda ley of specific gravity 1.15 to 1.175 (30° to 35° Tw.), and is gradually heated up until a pressure of 4 to 5 atmospheres is attained (corresponding with a temperature of about 150° C.), which is maintained for some hours. At the end of this time the soda has dissolved silica to approximate saturation; the liquor is then blown off into a settling tank, and the clear portion used for intermixture with soap.

temperature of 190° to 215° C.) At this higher temperature the carbonated alkali is stated by the inventor to act as efficiently as caustic alkali at lower pressures.

Calculation of Quantity and Strength of Ley required and of Composition of resulting Soap.—Much the same general principles apply in the case of the soaps at present under discussion as in the case of those prepared by direct neutralisation of fatty acids (p. 454), the chief difference being that in the present instance no water is formed, whilst the glycerol produced instead must be taken into account. If E be the saponification equivalent of a mixture of triglycerides, E parts by weight of the mixture will require 40 parts of NaOH, or 57.1 parts of KOH, for saponification, and will produce by acting thereon $\frac{92}{3}$ parts of glycerol, in accordance with the equation.

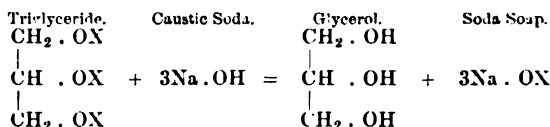

Suppose that a soda ley is used, containing m parts of neutral saline matters (chloride, sulphate, &c.) per 100 of NaOH; and that the proportion of ley employed is such that for 100 parts of NaOH converted into soap n parts are employed in excess. The total NaOH employed will, consequently, be $40 \times \frac{100+n}{100} = 0.4(100+n)$ parts for E parts of fatty matter as before; whilst a given weight of ley, W, will contain, as before—

NaOH,					0.4 × (100 + n)
Saline matters,		$\frac{m}{100}$			$\times 0.4 \times (100 + n) = m \times 0.004 \times (100 + n)$
Water, W - 0.4(100 + n) - 0.004 × m(100 + n) =					W - 0.004(100 + m)(100 + n)
			Total,		W

Hence the resulting soap mass (neglecting mechanical losses and evaporation) will contain—

Soda soap,	$E + 40 - \frac{92}{3}$				= E + 9.33
Glycerol,	$\frac{92}{3}$				= 30.67
Excess of NaOH,	$\frac{n}{100} \times 40$				= 0.4 × n
Saline matters,					0.004 × m(100 + n)
Water,				W - 0.004(100 + m)(100 + n)	
			Total,		E + W

In the case of a potash soap, if m parts of neutral saline matters be present per 100 of KOH, and if n parts of KOH in excess be used per 100 converted into soap, the total KOH used will be $57.1 \times \frac{100+n}{100} = 0.571 \times (100+n)$ per E parts of triglyceride mixture; whilst a given weight of ley, W , will contain—

KOH,	0.571 × (100 + n)	
Saline matters, $\frac{m}{100} \times 0.571 \times (100+n) =$	0.00571 × m × (100+n)	
Water, $\left\{ W - \frac{0.571(100+n) - 0.00571}{m \times (100+n)} \right\} =$	$W - 0.00571(100+m)(100+n)$	
Total,	W	

Whence the entire soap mass produced will consist of—

Potash soap,	$E + 57.1 - \frac{92}{3}$	=	$E \times 26.43$
Glycerol,	$\frac{92}{3}$	=	30.67
Excess of KOH,	$\frac{n}{100} \times 57.1$	=	0.00571 × n
Saline matters,		0.00571 × m × (100 + n)	
Water,	$W - 0.00571(100+m)(100+n)$		
Total,			E + W

Suppose that an admixture of silicate of soda, resinates of soda, syrup, or loading of any kind be made to the extent of w parts by weight, the composition of the total mass will be similarly arrived at; thus suppose a mixture of fatty matters of mean saponification equivalent 290 ($E = 290$) be saponified with excess of soda ley such that $W = 160$, $n = 15$, and $m = 10$, and that 150 parts of syrup be added per 290 of fatty matters, consisting of—

Sugar,	50 parts.
Water,	100 „
		150

i.e., let $w = 150$; then the composition of the resulting mass will be—

Soap,	290 + 9.33	=	299.33	=	49.89 per cent.
Glycerol,	$\frac{92}{3}$	=	30.67	=	5.11 „
Excess of NaOH,	0.4×15	=	6.00	=	1.00 „
Saline matters,	$0.004 \times 10 \times 115 =$	=	4.60	=	0.77 „
Sugar,		50.00	=	8.33	„
Water,	$160 + 100 - 0.004 \times 110 \times 115 =$	=	209.40	=	34.90 „
Total,	$290 + 160 + 150 =$		600.00	=	100.00

In the preparation of soft soap, the quantity of ley and fatty matter used are usually not adjusted to one another beforehand in the way requisite for cold process soaps; the ley is run in gradually during the operation until the requisite consistency is attained, more fatty matter being added in case of an excess of alkali having been used, practical experience in carrying out the manipulations being the guide to the quantities employed rather than accurate weighing or measuring. Similar remarks apply to most hydrated soaps prepared by boiling in open pans; on the other hand, for soaps made under pressure in autoclaves, &c., the relative quantities of materials must be carefully adjusted at the commencement of the operation, as the nature of the process does not conveniently admit of more material being added after the operation has been once commenced and the increased pressure attained.

SOAPMAKING PROCESSES WHERE THE GLYCEROL AND SOAP FORMED ARE SEPARATED FROM ONE ANOTHER.

Methods of this class substantially depend upon the general principle that whereas most alkali soaps are pretty freely soluble in pure water, especially when hot, the presence of various kinds of neutral saline matter—*e.g.*, common salt—and even of a large excess of caustic or carbonated alkali, renders them insoluble; so that the addition of salt or strong ley to an aqueous soap solution causes the soap to separate or precipitate in more or less solid flakes, the physical structure of which is more akin to that of crystalloid substances than to the colloid gum-like form in which transparent soap is obtained. The process of manufacture may accordingly be broadly described as consisting of boiling up the fatty matter to be saponified with comparatively weak alkaline fluids not used in excess, but employed in such quantity that when the alkali has been practically all neutralised by combination with the fatty acids the great majority of the fatty matter is decomposed, the remaining portion being distributed through the soap solution formed as a sort of emulsion. At this stage, on adding solid salt or strong brine, the dissolved soap is thrown out of solution and separates as a more or less granular curd, carrying with it the unaltered fat; the watery fluid containing the liberated glycerol being run off, the pasty imperfect soap is further treated with successive small quantities of stronger ley, being boiled up therewith until the saponification is complete. Finally, the soap is “finished” by one or other of various kinds of operation, according to the nature of the intended product. For “mottled” soaps, the curd resulting after complete saponification is boiled down (by dry steam, or in the older way of working, by

free fire), together with excess of strong ley, until it acquires a sufficient consistency—*i.e.*, until it is so thick that on running into the frames the coloured impurities present (iron soap, &c., formed during the process, or produced by adding green vitriol, &c., to the curd) are unable to sink to the bottom by gravitation; in which case, as the mass cools and solidifies, these coloured matters segregate into veins producing “mottling” of the old fashioned type.*

For “fitted” soaps, the curd produced after complete saponification is effected is allowed to stand awhile so as to separate from the leys; these are run off, and the curd boiled up with wet steam and weak leys or water until it is sufficiently thinned in texture to permit of the coloured heavier metallic soaps falling to the bottom by gravitation on standing; with rosin soaps more particularly, peculiar textures (“coarse fit,” “fine fit”) are thus arrived at, respectively suitable for different purposes.

Curd Soap.—For “cleansed” curd soaps, the diluted curd thus freed from coloured impurities is pumped off into another copper, and there boiled up with dry steam and a small quantity of strong ley until again concentrated to the required extent (*i.e.*, until the curd, freed from ley by subsidence, has the desired proportion of water associated with it); the water retained by the curd being less the longer the boiling is continued, and the stronger the ley (pp. 470, 486).

In boiling for curd soap,† the first saponification operation is usually carried out by running into the copper caustic leys of strength not exceeding specific gravity 1.05 to 1.075 (10° to 15° T.),‡ together with the melted fatty matters, and boiling them up together. The way in which this is done varies much in different cases and in different districts; sometimes the whole batch of “goods” (fatty matters) is run in, and then a fraction of the ley, and the whole boiled up, more ley being added from

* Totally distinct from the modern mottled soaps of highly watered and silicated character—*vide* p. 472.

† British curd soaps are almost invariably made from tallow as chief basis, the hard difficultly lathering character of pure tallow soap being modified by the addition of other oils and fats (small quantities of cokernut oil, more or less cotton seed or groundnut oil, lard, and so on), according to the object in view. On the Continent, and especially in France, vegetable oils are used in much larger proportion; thus Marseilles (Castile) soap is supposed to be made almost wholly from olive oil, and, in point of fact, is chiefly prepared from the highly sophisticated mixtures sold under that name; and even in those cases where tallow is used, a pretty large proportion of mixed vegetable oil is generally also added, rape oil being generally one of the constituents added to give lathering qualities.

‡ Leys containing more than some 5 per cent. of Na_2O act much less slowly on tallow and most other oils and fats than weaker solutions, at any rate in the first instance. When, however, the action is once fairly started, somewhat stronger leys may be run in (in small quantities at a time).

time to time. Sometimes the majority of the ley is run in first, and the goods added in successive portions, with continuous boiling. More frequently the ley and goods are run in alternately until the full complement of the latter is in the kettle, with somewhat less than the corresponding quantity of ley, the rest of which is subsequently added. When wet steam is used to heat up the copper the leys initially employed may be a little stronger than if dry steam be used on account of the dilution with condensed water; the later leys may also be stronger than the first ones, as they become greatly diluted with the water already present from the former leys. The effect of the action of the hot ley on the melted fatty matter is to "kill the goods"—*i.e.*, to emulsify the whole, so that no distinct layer of melted fat swims up on taking a sample.

When the saponification has gone on to such an extent that a large fraction of the glycerides is acted upon and but little alkali remains dissolved in the ley, the whole mass forms a homogeneous pasty mass, consisting of the half made soap with portions of emulsified fatty matter not yet saponified distributed throughout it.* In this state it is known as "close" soap (in some districts, as being in a "hitch" or "glue"). If too much ley has been added this peculiar texture is not attained, a sample taken out on a trowel exhibiting more or less marked tendency to separate into two fluids, one more watery than the other; whilst, if the boiling has not been continued long enough, or if the ley be too concentrated, a large surplus of undecomposed fat is visible, giving a greasy texture to the imperfectly made soap that thus separates from the watery ley. With proper care,

* It is extremely probable that the saponifying action of the alkali is exerted in three stages, forming successively one, two, and three molecules of soda soap; thus (in the case of stearin)—

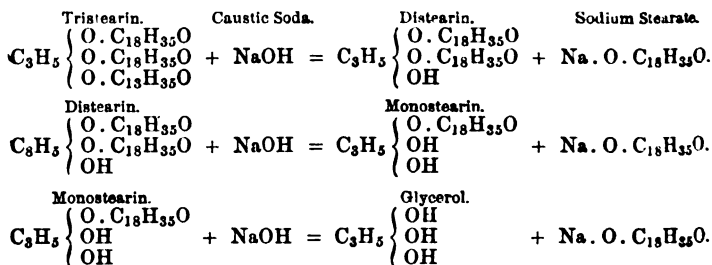

On this view "half made soap" consists of a mixture of sodium stearate with emulsified tristearin, distearin, and monostearin, uniformly disseminated through the water as a sort of jelly. A circumstance favouring this view is that the quantity of glycerol obtainable from the first spent leys is considerably less than the amount corresponding with the goods killed, not much above one half as a rule.

guided by indications only obtainable by practical experience, the requisite physical condition is attained, representing a state of matters where most but not quite all of the fatty matter is saponified, whilst practically all the caustic soda in the leys has been used up, furnishing an aqueous soap solution, or thin jelly, with a little emulsified fat disseminated throughout.

Graining.—The next stage consists in “graining” or “cutting” the soap by the addition of sufficient saline matter to render the dissolved soap insoluble in the resulting weak brine. For this purpose common salt is used, either solid fresh salt or that regained from previous batches of liquor during boiling down to recover glycerol (p. 514); or a strong brine is run in. The quantity added depends on the proportion of water already present in the copper relatively to the soap, which in turn depends on the strength of the leys used and the quantity of water condensed from “wet” steam; moreover, soaps containing much coker or palmtree oil require more salt than others, *ceteris paribus*. When sufficient salt is present in the watery liquor, a sample of the contents of the copper taken out on a trowel shows a mass of grains of semisolid soap, whilst a clear watery fluid runs away, which should not be markedly alkaline to the taste, and should throw up no scum of fatty acids on acidulation; showing that practically all the soda used has been converted into soap, and all the soap formed thrown out of solution by the addition of sufficient salt. Explosive evolution of steam (violent “bumping”) is very apt to occur during the graining process, whence the use of a fan and curb (p. 433) in moderating the frothing, whilst the kettle or copper used is only partly filled with materials.

After standing for a few hours (steam being shut off) the contents of the copper separate into watery “spent ley” which is run off and utilised (for glycerol extraction, &c.), and pasty “grain soap” consisting of about 3 parts actual soap to 2 of adherent water: this is either finished at once (usually pumped off into a smaller copper, or mixed with another batch from another copper, there being less liability of violent frothing over during the subsequent stages); or else more goods are added with weak ley and the boiling recommenced as before until the new batch of fatty matters is properly “killed,” when the whole mass is again salted out.

The grained soap, freed from spent ley, is then boiled up with wet steam and an additional quantity of somewhat stronger ley containing some 9 per cent. of NaOH (specific gravity about 1.09 to 1.11) gradually run in so as to complete the saponification; the quantity finally added being sufficient to cause the mass to separate into two (aqueous ley, and soap paste), the excess of caustic soda throwing the soap out of solution just as salt does. In some cases this operation is carried out in two stages, the

alkaline "half spent" ley run off in the first stage being utilised for killing fresh goods; this ley washes out entangled brine and contains most of the remaining glycerol developed by the completion of the saponification. In the second stage sufficient water is added (including that condensed from wet steam) to cause the paste to again assume the "close" state by dilution of the leys admixed with it, and the boiling continued long enough to ensure the saponification of the last portions of glycerides, when the soap is again grained or "made" by running in sufficient stronger ley to throw it out of solution in grains. Finally the half spent leys are partly, but not wholly, run off, and the soap paste and remaining ley boiled up by means of the dry steam coils, so that water is evaporated, whereby the residual ley becomes more concentrated, and the soap paste less watery (p. 467): when the paste sets on cooling to the required consistency and degree of hardness, the boiling is stopped and the mass allowed to stand some hours so that the leys and curd may thoroughly separate from one another: the curd is then transferred to the cooling frames. Unless purposely watered or boiled down to a less extent, curd soaps generally contain only 20 to 25 per cent. of water. When required to be as white as possible, the curd is allowed to stand for some time before the final boiling operation, so that coloured impurities may subside; the "cleansed" curd is then ladled or pumped off into another copper in which the boiling down with close steam is effected.

The time occupied during these various operations varies with the scale of operations and the skill of the workman: with batches of 40 to 50 tons of goods (tallow and rosin for yellow soap) the "killing" may be effected by an experienced hand in one day, and the further process up to "making" the soap carried out on the next day, the whole being furnished on the third day (Lant Carpenter).

British curd soaps are usually made with tallow as chief ingredient with comparatively small admixtures of other oils and fats; they do not lather very freely, and "waste" in hot water less rapidly than many other kinds of soap. The term "curd" soap, however, does not necessarily denote a tallow soap, but rather a soap boiled in a particular way.

Fitted Soaps.—In the manufacture of curd soaps more or less of the alkaline ley on which the soap is finally boiled, is necessarily left entangled in the interstices of the soap, incompletely removed by gravitation whilst standing; so that on analysis a curd soap thus prepared always shows a considerable proportion of "free alkali." In order to eliminate this an operation termed "fitting" is carried out, more especially in the case of rosin (yellow) soaps, whereby a peculiar texture is attained as the result. The "made" soap is allowed to stand some twelve hours or more so as to bring about as complete separation of

ley and curd as possible, and the half spent ley completely pumped away. Wet steam is then turned on, the condensation of which dilutes the ley still entangled in the interstices of the soap grains. With a particular stage of dilution (attained if need be by adding water to dilute further, or a little stronger ley if the dilution have gone too far) the mass of soap acquires the property of allowing a watery soap solution to separate at the bottom of the mass on standing (for some days with large batches, for twenty-four hours with smaller ones), whilst the rest of the soap forms a mass of jelly-like flakes, which solidify on cooling to a yellow, somewhat waxy and translucent solid, usually containing a little under 30 per cent. of water. Before this cools, it remains sufficiently soft to allow all dirt and solid impurities, such as coloured metallic soaps (containing iron, &c.), to subside by gravity, so that the lowest watery stratum is very dirty and much discoloured, and in consequence is known as the "negur" (sometimes spelt *negre*, *nigre*, *nigger*, &c.) The uppermost layer of the "neat soap" resting on the negur generally solidifies whilst standing to a solid frothy crust known as the "fob."*

The character of the "fit" attained, whether "fine" or "coarse," is judged by the indications observed on sampling the mass from time to time with a trowel; when the physical indications known by experience to denote the desired constitution of the mass are observed, the boiling is stopped, and the copper covered over to keep in the heat, the whole being allowed to stand at rest for from two to six days according to the size of the batch. Finally the cover is removed, the fob carefully cut away, and the still soft and semifluid neat soap pumped into the frames. After cooling, fitted soaps generally contain notably more water than curd soaps; from 28 to 33 per cent. is usually present in nonsilicated genuine fitted soaps. The fob is generally worked up with the next batch; the negur is either worked up with coarse fats and darker rosin and made into a brown rosin soap, or is utilised for making mottled soap.

Mottled Soaps.—In the earlier half and middle of the present century the majority of soap manufactured was of the curd class, and being made from leys directly prepared from black ash without purification, generally contained more or less sulphide of iron, or metallic soaps disseminated through it, derived from the impure liquors, or in some cases purposely added (in the form of raw or calcined green vitriol = ferrous sulphate, &c.) The curd was boiled down until the proportion of water therein was reduced to a quantity not exceeding about

* Society has been compared with a pot of porter, "dregs at foot, scum at top, and good liquor in the middle;" a copper of fitted soap with "negur" and "fob" as the extremes and clean "neat soap" in the midst, would be quite as apt a comparison.

20 to 23 per cent., and more frequently lying between 17 and 20 per cent.; after standing and running off the leys, the whole was well intermixed, and the greyish or otherwise coloured mass run into the frames. During cooling and solidification the colouring matters (chiefly iron soap) segregated from the rest of the mass into veins; so that when the solid soap was cut across a peculiar characteristic marbling or mottling was evident. By exposure to air the iron soap changed its colour from bluish grey to red in consequence of oxidation, forming what was known in the Marseilles district as the *Manteau Isabelle*. As this effect could not be produced in the case of a curd soap insufficiently boiled down (on account of the thinner texture permitting the heavier metallic soaps, &c., to sink completely to the bottom, like the negur of a fitted soap), the existence of a mottled appearance came to be regarded as a criterion of good quality so far as absence of an undue excess of water (say not above 20 per cent.) was concerned. "Castile," "Marseilles," "Olive" and other mottled soaps of this class, although still manufactured to some considerable extent, are, however, but little made at the present day for household use as compared with other varieties of mottled soaps in which the one especial good point characterising the old mottled soaps is wholly absent—viz., that only a limited amount of water is present. A considerable degree of skill is requisite in adjusting the proportions of materials used so that a maximum of water can be incorporated without unduly interfering with the veining of the mass. Usually silicate of soda solution is used as stiffening agent, the fatty matters being selected according to the judgment of the maker, and generally containing a considerable proportion of palm kernel oil or coker-nut oil, on account of the property of these oils to form soda soaps possessing considerable stiffness even when largely watered (p. 462). After admixture of the silicate the pigments intended to give the mottle are added, and the mass thoroughly crutched until sufficiently stiffened to run into the frames; these are usually made of wood so as to allow the mass to cool as slowly as possible and cause the mottle to "strike" properly into veins. Soaps thus made and "filled" with water and silicate often contain 50 per cent. and upwards of water and not more than 40 to 45 per cent. of actual soap.

Absolutely no good purpose whatever is fulfilled in communicating a mottle of this kind to household scouring soaps: the only effect is that the public is induced to buy a greatly inferior article on the strength of the reputation for quality gained years ago by mottled soaps of the old style. Whatever advantages may be gained by the addition of silicate as a cheap detergent, these are wholly independent of the mottling.

A method of preparing hard soda soaps without employing caustic soda (sometimes referred to as the "old German process")

was formerly of considerable importance, although at the present day the relative prices of potash and soda are such as to render the process inapplicable, except in backwoods districts where potashes are more readily obtainable than soda ash or caustic soda. The tallow, or other mixture of fats and oils to be saponified, is boiled up with potash ley (made by causticising potashes with lime) much as in the process of soft soap making, until a syrupy "close" soap is obtained; this is then salted out by the addition of common salt or brine, whereby a curd is obtained mainly consisting of soda soap, the potash soap and sodium chloride reacting on one another by double decomposition (pp. 451, 489). The curd thus obtained is finished by repeating the operations of boiling up with potash ley to complete saponification, and salting out so as to transform the majority of the potash soap still present into soda soap; the curd ultimately obtained after a sufficient number of such treatments being finally boiled up with ley until any entangled salt is washed out, whilst the ley becomes sufficiently concentrated for the curd to separate properly.

In all probability, hard soda soaps were first prepared on a comparatively large scale by this kind of process, rather than by saponification with caustic soda direct; although the use of "maritime alkali" (barilla) appears to have been practised in the Marseilles district as long as the soap manufacture has existed there. In inland districts, however, where seaweed ash was practically unattainable, or at any rate costly as compared with vegetable potashes, this "old German" process was the one chiefly employed for making hard soaps until the discovery by Leblanc of the method of preparing soda from common salt that bears his name.

SPECIAL VARIETIES OF SOAP.

Rosin Soaps (Yellow Soaps).—In the manufacture of soaps of this description ordinary rosin (colophony) is used as an ingredient, the mixture of alkaline salts of rosin acids and of fatty acids being peculiarly well adapted for certain purposes. In one method of procedure (Meinecke's) crude turpentine is added to the soap pan, which is fitted with a still-head, so that the spirit of turpentine volatilised along with the steam is condensed and utilised. A much more frequently used process, however, is to separate the spirit and rosin by the ordinary distillation process, and to mix the latter with the fats, &c., to be saponified, so that a mixture of the alkali salts of fatty and resinous acids results; whilst a further improvement (sometimes termed the "French process" for rosin soap) consists in dissolving the rosin in hot alkaline ley separately (p. 453), adding the resulting

resinate of soda solution to the finished soap, well crutching the two together; or adding it to the soap in the pan and intermixing by boiling up for a few minutes.

Rosin soaps of the better quality are generally "fitted" (p. 470). When made from sound fatty matters and light coloured rosin ("windowglass rosin") they possess a peculiar odour not disagreeable, and are known in the south of England as "Primrose" soap;* such soaps usually contain about 30 to 33 per cent. of water and 66 to 69 per cent. of actual soap (including resinate of soda). Coarser rosin soaps made from dark brown rosin, damaged fats, horsegrease, and the like, have generally a more or less marked unpleasant animal odour, partly disguised by the rosin, or by the addition of nitrobenzene (artificial oil of almonds, or *essence de mirbane*) or other cheap scents.

Rosin soaps are generally preferred as stock soaps for transparent soapmaking by the spirit process, as the presence of alkaline resinates facilitates the acquisition and retention of the colloid structure requisite for transparency; moreover, a well fitted rosin soap will dissolve practically completely in spirit, not leaving behind any sodium carbonate or other insoluble matters requiring separation by subsidence or filtration. A similar product is also obtainable by dissolving in spirit an ordinary curd soap (cut into shavings and dried) simultaneously with rosin, whereby the free alkali contained in the stock soap is neutralised, and an alcoholic solution of mixed fatty and resinous soaps directly obtained.

The determination of the relative amount of resinous acids and fatty acids present in a given sample of soap is in many such cases a somewhat important matter; this may be effected by the methods described on p. 501, *et seq.*

Silicated Soaps.—Household soaps, properly so-called, consist of the alkaline (potash or soda) salts of certain organic acids, either belonging to the various fatty acid series, being derived from natural oils and fats, or to other series of more feebly marked acids derived from resins, more especially colophony. The older soaps (of the first half of the present century) were essentially of this character; but a considerable proportion of those now manufactured are cheapened by the admixture of various ingredients possessing more or less marked detergent power, the addition of which enables a given weight of so-called soap to be manufactured from a greatly decreased quantity of fatty matters. Of these detergent substances, obviously the most natural constituents are the alkalies themselves, either in the form of hydroxides (caustic alkalies) or as carbonates; in the

* In some districts in the north of England the term "primrose" is applied to greatly inferior articles, usually largely watered and treated with silicate of soda to stiffen them, so that the actual soap present constitutes notably less than one half the mass, like the inferior mottled soaps described on p. 472.

manufacture of "oil" soaps (oleic acid soaps, p. 452) these constituents are introduced by the simple process of using a larger quantity of alkaline ley than is equivalent to the fatty acids; in other cases, the alkalis are dissolved in water and crutched into the soap before framing. The introduction of silicate of soda solution has various advantages as compared with that of caustic alkalis, proper incorporation being more easy; whilst for such purposes as scouring floors, &c., the increased detergency thereby gained is distinctly advantageous. For laundry soaps, on the other hand, the utility of silicates is far less manifest; so much so, that various much advertised laundry soaps of the present day are purposely prepared without that ingredient (sodium carbonate being in some cases used instead); to which circumstances they largely owe what superiority they may possess over other silicated soaps.

One notable advantage gained by the admixture of silicate of soda with soaps made from cheap soft fats, &c., is that the texture of the bar of soap is considerably stiffened and hardened, so that the soap does not waste so rapidly in hot water or when rubbed against the clothing, &c., to be washed, as it otherwise would necessarily do.

Normandy Soaps (Sulphated Soaps).—In order to harden and stiffen a comparatively soft soap mass various neutral salts may also be employed, more especially sodium sulphate or thio-sulphate. The use of these stiffening agents was originally introduced by Dr. Normandy, not for purposes of adulteration or "filling," but in order to enable useful household scouring soaps to be made from materials that otherwise would give a product too soft for economical use in scrubbing, especially with hot water. When sodium sulphate (Glauber's salt) was used, the crystallised salt (not salt cake) was heated so as to fuse in its own water of crystallisation,* the liquid being immediately crutched into the hot soap; from one-fifth to one-third of the weight of the soap being thus added. The soaps thus made rapidly become unsightly through efflorescence; so that their use at the present day is not large, other stiffening agents (more especially alkaline carbonates and sodium silicate) being preferred.

Aluminated Soaps.—Aluminate of soda has been proposed, and to some extent used, as a substitute for silicate of soda in the preparation of scouring soaps, for which purpose it does not seem to have any special advantages or marked disadvantages.

Borax Soaps.—The addition of borax to laundry soaps is sometimes made, that salt possessing considerable detergent power without injurious action on textile fibres; it is usually

* If salt cake is used, it must be dissolved in the right quantity of water and treated with a little soda ash, so as to neutralise the free acid present and precipitate the ferric oxide contained as sulphate.

supposed, moreover, to have a special blanching action on linen. Some so-called "borax soaps," however, are in the market that contain only extremely minute amounts of borax, or none at all.

Phosphated Soaps.—In order to diminish the waste of soap with hard water through double decomposition by the lime and magnesia salts present, H. Grimshaw * adds an alkaline phosphate to the soap, with the object of forming calcium and magnesium phosphates instead of lime and magnesia soaps insoluble in water.

Paraffin Oil and Petroleum Soaps.—Hydrocarbons of the paraffin series possess the physical property of forming jellies when admixed with soap solutions under suitable circumstances; a small quantity of soap will thus solidify a large quantity of hydrocarbon, a circumstance taken advantage of in manufacturing "solidified petroleum" for fuel. On the other hand, 10 or 20 per cent. of such oil can be crutched into a hot soap paste without materially interfering with its setting on cooling, so that a large amount of "loading" may be thus effected. With certain kinds of transparent soap (made by the cold process, pp. 458, 482) this addition is frequently made.

For laundry purposes the diluting effect of the hydrocarbon oils is more or less compensated by an increased detergent action: greasy linen, &c., soaped with "paraffin soap" can often be cleansed with less rubbing and friction than would otherwise be necessary because the hydrocarbon tends to dissolve the grease and so to facilitate the detergent action of the soap so far as other dirt is concerned.

Sand, Fuller's Earth, Pipeclay, Kaolin, and Brickdust Soaps.—When soap is required for household or other cleansing purposes to be used in conjunction with fuller's earth, powdered brickdust or pumicestone, sand, emery, or such like materials so as to brighten metallic surfaces, cleanse greasy paint (insides of baths, &c.), and so on, it is often found convenient to prepare blocks of mixed mineral powder and soap for sale; these are made by crutching the pulverised pumicestone, &c., into the hot melted soap in as large a proportion as is consistent with its sticking together in blocks when cold, and are then sold under various proprietary names, chosen according to the fancy of the maker. For general cleansing purposes such mixtures are often very handy; but the price charged, although moderate enough as regards the weight of the block as a whole, is generally high with respect to the quantity of soap actually present therein. Superior kinds of such soaps are sometimes sold as "tooth soaps," prepared by incorporating with a good kind of remelted toilet soap some 10 to 20 per cent. of finely powdered marble or pumicestone, cuttlefish bone, prepared chalk, &c., &c.

Disinfectant Soaps.—A large variety of soaps are in the market consisting of ordinary soaps of more or less good quality

* English Patent, No. 983, 1890.

into which have been crutched, before finally cooling and solidifying, fluid or other disinfecting materials, more especially those derived from coal-tar products—*e.g.*, carbolic and cresylic acids, naphthol, naphthalene and creosote oils, &c. ; or the artificial camphoraceous products got by the oxidation of oil of turpentine (Sanitas oil) ; or hydrocarbons, such as terebene ; or various inorganic germicide materials. Of these different products, a considerable number are highly valuable for the particular purposes for which they are intended ; but the value of others is, at the best, only small as antiseptic and disinfectant agents.

To this category also belong a variety of "medicinal" soaps, usually put up in tablet form like "toilet" soaps (p. 478) ; in these a stock soap of more or less good quality forms the basis, sulphur, iodine, ichthyol, mercurial preparations, or other medicaments supposed to exert beneficial action in certain cases when thus applied to the skin, being mixed in either by remelting or milling, or in some cases being added to the mass formed by the cold process before it finally solidifies.

Coldwater Soaps.—Various soaps are sold under this name, the alleged advantage of which is usually stated to be that they will lather freely with cold water and therefore do not require clothes, &c., to be boiled. In many cases a more accurate description would be that they dissolve so freely in hot water as to be highly wasteful when used therewith. They generally consist of more or less watered soaps* containing cokernut or palm kernel oil to give consistency, with a liberal intermixture of potassium or sodium carbonate (less frequently of silicate) to harden and give increased detergent action ; in practice they are equivalent to a mixture of true soap and soda crystals, and like sand and brickdust soaps they are accordingly very handy in use ; but in general the price is high as compared with the actual amount of soap present.

Soap Powders.—The above remark applies *a fortiori* to these substances which in general consist of ground-up soda crystals (sometimes of ordinary soda ash) with more or less pulverised dry soap intermixed ; they are usually highly efficacious as detergents, but somewhat dear as compared with the value of the alkali present and the soap, taken separately from the water of crystallisation and other inert constituents.

Starch Soaps, Oatmeal Soap, &c.—More than one patent has been taken out for the preparation of products where *potato flour, starch*, and similar materials are intermixed with ordinary

* Some few "cold water" soaps do not contain more than 20 to 25 per cent. of water, and are made with only comparatively small additions of potassium or sodium carbonate, the former being preferably used to soften the texture, a result also partly brought about by the use of semidrying oils as ingredients—*e.g.*, cotton seed oil.

soaps. The advantages of such mixtures are difficult to understand. *Oatmeal*, however, well intermixed with some reasonably good quality of stock soap, enjoys some degree of popularity as a "skinsoap." *Bran* and *gluten* have been used for the same purpose; as also *dextrine*, *Iceland moss* and other lichen jellies, *sawdust*, *cornflour*, and various analogous substances.

TOILET AND FANCY SOAPS.

The term "toilet soap" is generally supposed to denote a superfine variety of soap specially prepared with the object not only of effecting cleansing during ablution, but of doing this in the most delicate way with regard to injurious action on the skin, thus serving as a sort of cosmetic. Some of the so-called toilet soaps in the market well fulfil this description; but, unfortunately, many others are largely advertised and sold which are of a far less satisfactory character, either through imperfections of manufacture (more especially presence of excess of alkali), or because of their having an objectionable action on tender skins through admixture of other ingredients (particularly cane sugar).

Some varieties of so-called toilet soaps are simply household soaps of the finer class, more especially curd and yellow soaps made from first class materials, cut up into tablets, and stamped into shape by one or other of the various kinds of stamping press referred to on p. 444. As a rule these are scentless, but sometimes a small proportion of cheap essential oil or other perfume (such as citronella, mirbane, &c.) is crutched in before framing.

More frequently stock soaps of good quality are prepared on the large scale from choice, or at least sound, materials, and are then cut up, intermixed or blended, remelted, and again framed, working on a smaller scale: usually scenting materials are introduced just before transferring to the frames, and in some cases emollient ingredients or unguents—*e.g.*, lanolin, vaseline, beeswax, spermaceti, or various undecomposed glycerides, such as the finest beef marrow, lard, the so-called "beef stearine" separated from the more fusible fats in the manufacture of margarine (p. 309), &c. Of late years "superfatted" soaps of this description (in some cases made by remelting, in others by milling—*vide infra*) have been somewhat largely "boomed," the special advantage derived from their use being supposed to be that an extremely thin greasy film adheres to the skin after use, which more or less prevents the drying and chapping action otherwise produced by ordinary soaps on tender skins. Opinions differ widely as to how far this alleged advantage is really gained or not, some regarding the presence of a few per cents. of glycerides in the soap as actually furnishing a

protective film of the kind, rendering the outer layer of the skin soft and supple; whilst others consider that inasmuch as the action of water on perfectly neutral soap always liberates more or less free alkali, which emulsifies grease and enables it to be washed off, whilst any excess of alkali naturally contained in the soap accelerates the action, the notion of an adherent protective grease film is *a priori* improbable; the advantage of such soaps lying rather in their freedom from excess of alkali and other objectionable skin roughening substances such as sugar. On the whole, the preponderance of opinion rather seems to be in the direction of regarding nonglyceridic unguents (lanolin, spermaceti, &c.) as being more "emollient" when thus admixed with soap than glyceridic materials such as usually found in "superfatted" soaps—*i.e.*, when all other things are equal, especially absence of free alkali; moreover, the presence of unsaponified fatty matters seems sometimes to facilitate discoloration on keeping through the development of a kind of rancidity.

In some cases "pearlashing" (pp. 451, 489) is adopted to improve the texture and lathering power; when this is done the pearlashing liquor (solution of potassium carbonate) is simply crutched in with the other ingredients before framing. Since an equivalent of sodium carbonate is formed for one of potassium carbonate introduced, obviously, a pearlashed soap is apt to be strongly alkaline and objectionable for persons suffering from tender skins, or a tendency to acne or eczema.

Milled Soaps.—"Perfumers' soaps," sometimes known as "little-pan soaps," were formerly largely made by perfumers by means of the cold process. The fatty matters thus employed were generally of excellent quality, being mainly the oils and fatty cakes used to absorb flower perfume (odorous essential oils) by packing the fat cakes and flower petals together, or by passing air over the flowers and bringing it in contact with oil, &c., to absorb the volatile odorous matter; after the oil or fat was fully charged by numerous repetitions of the process it was treated with alcohol, whereby a flower essence was obtained by dissolving out the essential oils, leaving behind a delicately scented fat, capable of furnishing a deliciously perfumed soap. Owing, however, to the necessity for avoiding heat as much as possible in the preparation of the soap, it often happened that these soaps contained simultaneously much undecomposed fat and a large amount of free alkali. Accordingly, of late years they have been largely supplanted by "milled" soaps, where stock soaps of good quality are "stripped" or reduced to chips and dried until only a few per cents. of moisture are retained, and then ground (together with perfumes, colouring matters, glycerine, or other emollient ingredients, &c., as required) between rollers until reduced to a stiff putty-like mass, which is

then squirted or screwed into bars and so formed into tablets (p. 448). The advantages of this method are, firstly, that inasmuch as no artificial heat is applied, delicate flower perfumes, &c., can be readily incorporated with the soap mass, which it would be impossible to use with a remelted soap because the heat would dissipate or destroy the odorous matter; and secondly, that as the resulting tablets usually contain only a small quantity of water, a given weight of soap tablet generally contains a much larger quantity of actual soap than another tablet of the same weight prepared by remelting or by the cold process, whilst, being harder and stiffer, it lasts longer, wasting less rapidly during use. By suitably choosing the stock soaps used, employing only such as have been prepared from first class oils and fats, &c., and refined or otherwise treated to remove "free" alkaline matters, "fancy" and "toilet" soaps of the finest possible qualities are thus readily obtainable. Frequently the stock soaps are partly made with potash and partly with soda, so as to arrive at a suitable texture through the softer nature of the potash soap, as well as to produce a better lather.

In this connection it is worth noticing that there is some reason for supposing that soap with which an extremely large proportion of flower essences and essential oils is incorporated, may thereby become less suitable for use by persons suffering from tender skins than would be the case with a lessened amount of odorous matter, inasmuch as many essential oils of the kind possess more or less marked rubefacient (skin-reddening) action, analogous in character to the stimulating and blistering action of mustard, oil of turpentine, and similar substances. It is within the author's own personal observation that when the same high-class soap mass is used for preparing two differently priced fancy soaps, only differing in that the more expensive one is impregnated with a much larger proportion of scent than the other, persons possessing exceptionally sensitive skins can sometimes use tablets made from the less highly scented portion with impunity, whilst the employment of tablets made from the more strongly perfumed portion speedily sets up a disagreeable amount of skin irritation.

From the point of view of irritating skin action, however, the presence of sugar appears to be much more objectionable than that of most scenting materials, even in large quantity. Opaque fancy soaps are rarely, if ever, admixed with this adulterant; but very little transparent soap is in the market that does not contain more or less.

Brown Windsor Soap.—The term "Brown Windsor" has long been applied to a peculiar brown soap highly esteemed for toilet purposes. Originally this substance deserved its reputation; but as in the case of "mottled" soap, the perverted ingenuity of the modern adulterator has completely altered the character of the

great majority of toilet tablets sold under that name. The "Old Brown Windsor" of a generation or two back was simply a form of soap (usually mostly curd) that had been kept in stock for a great length of time, and occasionally remelted; with the result of acquiring a pretty deep brown tint through oxidation of fatty acids, &c., and of becoming practically wholly devoid of free alkali, any excess of alkali originally present being neutralised by the weakly acid oxidation products formed during keeping or "ageing," or whilst being remelted. Such a soap, pleasantly scented at the last remelting before making into tablets, and originally made from suitable materials, lathered sufficiently freely to be conveniently used, and had as little deleterious action on sensitive skins as is compatible with the hydrolytic properties of soaps generally. The modern substitutes, however, are frequently nothing but coarse soaps made from discoloured fats, and further browned by coaltar dyes or admixture of brown ochre: all sorts of scraps (including floor scrapings) incapable of utilisation in any other way are worked into the mass, which frequently is alkaline to a highly objectionable extent. In short, advantage is taken of the reputation deservedly gained in former years by an excellent article to sell under the same name an eminently inferior product. Similarly, so-called "White Windsor" soaps are sometimes to be met with, largely made from cokernut oil, highly alkaline, and wholly different in character from the genuine old fashioned brown article.

Transparent Soaps.—As already stated, soap can in many cases assume two distinct physical conditions, one a more or less distinctly crystalline form in which the "grains" retain associated by a sort of physical attraction a considerable quantity of water, the amount of which varies with circumstances—*e.g.*, a curd soap, when granulated from a dilute liquor with a minimum of salt or alkali, will contain as much as 35 to 40 per cent. of such associated water, which becomes gradually lessened down to 20 to 25 per cent. or less by boiling down with dry steam or free fire so as to concentrate the leys. The other is a structureless colloidal state, constituting a mass which under suitable conditions is clear and transparent like a strong jelly. Soft soaps (potash soaps) appear to have a stronger tendency to retain this colloidal state than hard (soda) soaps, so that it is only with comparative difficulty that they become granular; soda soaps, on the other hand, although granular when separated from watery solutions by means of salt, readily become colloidal when dissolved in alcohol, so as to form transparent masses when the solvent evaporates. This physical condition is facilitated in many cases by the presence of various other substances, of which glycerol is one of the best known; so that fats saponified by the cold process, even in the absence of alcohol, often yield transparent products owing to the production of glycerol during the process. Castor oil, in

particular, readily yields a transparent product in this way. Cane sugar possesses the same property; and being cheaper and easier to work with in some respects, is largely substituted for glycerol, to the great disadvantage of the consumer, excepting in one respect, viz., that whilst transparent soaps containing large percentages of glycerol are apt to "sweat," by attracting moisture from the air, sugared soaps do not deliquesce so markedly. Resinates mixed with ordinary fatty acid soaps generally form colloidal masses more readily than the latter alone; accordingly, rosin soaps are preferred as "stock" when granular soaps are to be rendered transparent. This tendency to transparency is often strongly marked even with water-made rosin soaps of good quality ("fitted" soaps), which generally become translucent and sometimes tolerably clear when spontaneously dried in not too thick masses.

Accordingly, two principal methods are in use for the preparation of transparent soaps. In the "spirit" process the stock soap is dissolved in spirit and treated as described (p. 445), rosin being sometimes added to the mass for the double purpose of aiding transparency and combining with free alkali so as to neutralise it.* The mass left when the bulk of the spirit is distilled off is usually turbid; but on slow drying in a warm storage room (temperature near 35° C. = 95° F.) it becomes clear, especially when a liberal addition of sugar has been made to the mass before finally casting in the frames. Usually the blocks are cut up into tablets which are shaped by stamping in blank dies, and then slowly dried, the final impression being given by a later stamping. When glycerol is added instead of sugar, the resulting transparent soap is as innocuous, even to the most sensitive skin, as any kind of soap can possibly be; but the same can by no means be said of sugared soaps (which constitute the large majority of those in the market), persons of unusually tender skins being generally unable to use such compositions long without suffering more or less severely in consequence.

Similar remarks apply to the transparent soaps made by the other process (cold process, p. 458); when sound fatty and oily matters are used, together with alkali not in excess, no sugar being employed, an article results of superior kind; but the great bulk of so-called "glycerine" soap made in this way is alkaline to an extent highly prejudicial to tender skins, besides being largely admixed with sugar,† whilst in many cases the oils used (chiefly castor oil, together with cokernut oil, &c.) are of such quality as to leave an unpleasant odour on the skin, easily

* Some transparent soaps thus prepared when dissolved in water and agitated with petroleum spirit, or when dried and percolated therewith in a Soxhlet tube, will yield several per cents. of uncombined colophony to the solvent.

† For a typical analysis of a soap of this kind (not loaded with hydrocarbons) *vide* p. 511.

perceptible when the scenting material has evaporated; and in addition, large percentages of valueless "loading" (petroleum hydrocarbons, &c.) are added to increase the weight. In short, transparent toilet soaps, like artificially mottled scouring soaps, are articles in the purchase of which caution is pre-eminently desirable. For further details concerning transparent and other toilet soaps and their manufacture, *vide* the author's "Cantor Lectures on the Manufacture of Toilet Soaps" (*Journal Society of Arts*, 1885).

Soap Leaves.—A very convenient form of soap for travellers is obtained by melting a good quality of stock soap with a little water, perfuming to taste, and passing sheets of tissue paper through the fluid; the paper thus filmed with soap is dried and cut up into leaves, one of which generally suffices for ordinary washing of the hands, &c., thus avoiding the necessity of having to carry about a wet cake of soap.

Marbled Soaps and Harlequin Soaps.—A peculiar marbled appearance is sometimes given to soap balls, tablets, &c., by remelting a more or less white stock soap, and running it into a small frame; a comb with wide teeth is then dipped into a colouring composition (melted soap with pigments or dissolved colouring matters), withdrawn, and passed through the semifluid soap in the frame, so as to streak it according to fancy. The same method is applicable to cold process compositions, before they have completely solidified. By cutting up pieces of variously tinted soaps into fragments, and scattering them through a cold process transparent soap mass on the point of solidifying, a mixture of transparent soap with variously tinted lumps interspersed is ultimately obtained; when cut up and stamped into tablets, these are sometimes sold as "harlequin soaps." Tablets are sometimes ornamented by stamping a device somewhat deeply, and then filling the grooves with melted coloured transparent soap, &c.

Shaving Creams.—Cold process soaps made from refined lard or other superfine fatty matters and caustic potash, not used in excess, are usually the basis of these preparations; to facilitate lathering, a small quantity of the finest cokernut oil is often added. The resulting mass is ultimately ground in a marble mortar, &c., with scenting materials (oil of bitter almonds for *almond cream*, and so on), glycerol or other emollient ingredients being added to taste, and sometimes tinting materials—*e.g.*, a few grains of vermilion per lb.—to give a faint flesh colour, &c. A perfumed concentrated alcoholic solution of soap forms a variety sometimes known as "liquid soap."

Neutralised Soaps.—For certain special purposes it is highly important that the soap employed should be as devoid of free alkali as possible. In order to effect this object a variety of methods have been proposed and more or less largely employed,

according to circumstances. In the generality of cases soaps that have been put through the operation of "fitting" (p. 470) are almost absolutely neutral, any entangled alkaline ley present in the curd before fitting having been washed out during the process; if, however, after "cleansing" in this way so as to separate coloured impurities, the soap be again boiled down on a fresh portion of ley, the resulting curd soap is always considerably alkaline through entangled ley. A method used with some degree of success consists in remelting (p. 441) the soap to be treated with a small proportion of fatty matter which becomes more or less saponified by the treatment; inasmuch, however, as the alkali present is generally carbonated, this method rarely gets rid of all the free alkali, excepting in cases where the additional fatty matters used consist largely of free fatty acids like some kinds of largely hydrolysed palm oil.* In the manufacture of transparent toilet soaps by the spirit process, any carbonated alkali present is left undissolved and is, consequently, separated by subsidence or straining; whilst if rosin be directly added, the free alkali present is more or less converted into resinate and so eliminated. When, however, resinous or fatty materials are added to a soap mass in the milling process, no action ensues between them and the free alkali; so that "superfatted" soaps thus prepared (without long continued fusion of the glycerides with the soap by remelting) often contain simultaneously excess of alkali and unsaponified glycerides, like imperfectly made cold process soap (p. 457). The author's ammonium salt process, referred to on p. 453, on the other hand, acts equally well in the way of removing "free" alkali, whether applied to soap shavings during the milling process, or to fused soap during remelting, or to soap curd, &c., in the crutching pan; any alkaline carbonate or hydroxide being converted into a neutral salt with simultaneous evolution of ammonia which mostly escapes.

CHAPTER XXI.

GENERAL CHEMISTRY OF SOAP—SOAP ANALYSIS.

In addition to various points previously discussed in connection with the general chemical and physical properties of oils, &c., a variety of other matters are of some interest relating to the properties of soaps of various kinds.

* According to A. Watts, the superiority of the madder purples for which the firm of Hoyle & Sons were long famous, was due to their practice of remelting the best soaps procurable with an additional quantity of palm oil.

As already explained, what is ordinarily meant by the term "soap" is simply the various substances obtainable consisting of the alkaline (potash and soda) salts of the various fatty acids contained as glycerides in oils and fats, and of the rosin acids contained in colophony and allied resinous matters. Numerous corresponding salts of the alkaline earths and heavy metals, however, exist, all of which, strictly speaking, are also soaps—*e.g.*, the lime "rock" obtained in the manufacture of candle stearine (pp. 365, 373), and the "lead plaster" obtained by mixing together olive oil (or other analogous oil) and litharge. As a general rule these earthy and metallic soaps are insoluble in water, at any rate as compared with alkali soaps; so that on adding a metallic salt solution to an aqueous solution of alkali soap, double decomposition occurs, and a precipitate is formed of the metallic soap. Thus, for example, the applicability of Clark's soap test for lime and magnesia in water depends on such actions—*e.g.*, in the case of stearates—

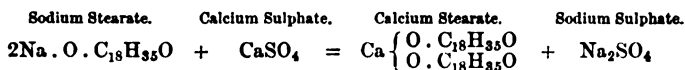

Similarly Gladding's test (p. 501) for rosin acids in soap depends on the precipitation of silver stearate, oleate, &c., insoluble in ether containing a little alcohol when silver nitrate acts on an alcoholic solution of mixed alkali salts; whereas silver resinate is soluble in that medium.

Alkali soaps often possess in a high degree the peculiar property of gelatin and other colloid bodies—*viz.*, that whilst on heating with hot water they apparently dissolve to an ordinary solution, on cooling this does not allow crystals of material to form through diminished solubility on account of lowered temperature, but instead sets to a more or less firm jelly. This property of "jellifying" is often used as a practical test of the value of soap for certain purposes; a known weight of soap is dissolved in water (conveniently $1\frac{1}{4}$ ounce to a pint = 20 fluid ounces, or 62.5 grammes per litre) and the solution allowed to cool; the rate at which the fluid gelatinises, and the texture of the resulting jelly are noted. Preferably the soap is dissolved in about half the total quantity of water, boiling, and when all is in solution the rest of the water is added cold.

Although alkali soaps are usually freely soluble in water, especially when hot, yet the presence of certain other substances in solution prevents their dissolving, whilst the addition of these substances to aqueous soap solution causes the precipitation of more or less of the dissolved soap; thus the process of "salting out" half made soap in the open pan boiling process (p. 469) depends on the less degree of solubility of soap in brine than in pure water. Similarly, when curd soap is boiled down on

an alkaline ley, the soap is rendered less and less soluble in the watery liquor as the concentration proceeds, and at the end of the operation is wholly insoluble therein, even if partially soluble at first when the ley was weaker.

The proportion of salt relatively to water required to render a given soap insoluble, obviously varies with the nature of the fatty acids present; thus whilst sodium stearate and palmitate are precipitated from solution by comparatively small amounts of salt, cokernut and palmnut oil soaps are sufficiently soluble to remain dissolved in seawater, which usually contains 3 to 4 per cent. of dissolved solid matters, mostly sodium chloride. In hot brine the solubility of soap is usually greater than in cold: thus in the course of a variety of experiments on the solubility of soaps in saline solutions Whitelaw found* that tallow soap was completely soluble to a clear fluid in a boiling solution containing not more than 3.0 per cent. of NaCl, the whole setting to a firm jelly on cooling; whilst palmnut oil soap dissolved clear in a boiling solution containing not more than 13.0 of NaCl, a large portion of the soap being thrown out of solution on cooling.

The curd thrown out of solution by salting retains an amount of associated water incapable of expression mechanically by moderate pressure in a dry cloth, and hence not in quite the same condition as ordinary mechanically entangled fluid; the amount of this water varies inversely with the concentration of the saline solution; thus the longer a curd soap is boiled down on the ley so as to concentrate this, the less is the proportion of moisture retained by the soap after separation from the ley and framing so as to solidify. In similar fashion, Whitelaw found that an olive oil soap retained the following amounts of water after half an hour's boiling with different brine solutions:—

Salt in Brine.	Water in Curd.
8 per cent.	31.6 per cent.
17 "	25.7 "
27 (saturated).	19.1 "

Hydrolysis of Soap Solutions.—When soaps are dissolved in absolute alcohol, or in spirit containing but little admixture of water, no visible decomposition ensues; a neutral soap gives a solution which has no action on suitable indicators—*e.g.*, phenolphthalein. If, however, water be substituted for spirit, the soap is more or less broken up into caustic soda and an acid soap—*e.g.*, in the case of stearate—

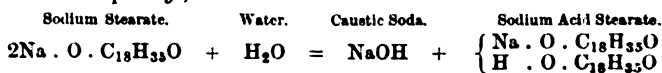

▲ A pretty way of illustrating this action is to boil a piece of dried

* *Journ. Soc. Chem. Ind.*, 1886, p. 50.

soap with alcohol to which a little phenolphthalein has been added, and filter the solution into a tall jar or large test tube; the solution should be strong enough to set to a firm jelly on standing. When set, a little distilled water is poured on the top of the jelly; this hydrolyses the soap in the top layer so as to turn it pink by the reaction on the phenolphthalein of the liberated alkali. On standing, the water gradually dialyses downward through the colloid soap mass, and the pink colour descends with it.

By adding salt to an aqueous solution of soap so as to salt out the curd completely, filtering off, and examining the filtrate alkalimetrically, the amount of alkali set free under given conditions can be determined; or the same result can be got at (with more trouble) by collecting the salted out curd, washing with brine over the vacuum filter, dissolving the curd in absolute alcohol, and titrating the acidity with phenolphthalein as indicator. A long series of observations thus made led to the following results:—*

Fatty Acids.	Mean Molecular Weight.	Hydrolysis brought about by x Molecules of Water.				
		$x = 150$	$x = 250$	$x = 500$	$x = 1000$	$x = 2000$
Pure stearic acid,	284	0·7	1·0	1·7	2·6	3·55
Nearly pure palmitic acid,	256	1·45	1·9	2·6	3·15	3·75
Crude lauric acid (cokernut oil),	195	3·75	4·5	5·4	6·45	7·1
Pure oleic acid,	282	1·85	2·6	3·8	5·2	6·65
Crude ricinoleic acid, . .	294	1·55	2·2	3·0	3·8	4·5
Chiefly stearic, palmitic, and oleic acids (palm oil tallow soap),	271	1·1	1·55	2·6	4·1	5·3
Chiefly tallow and rosin (primrose),	280	1·5	2·2	3·1	4·2	5·3
Cotton seed,	250	2·25	3·0	5·0	7·5	9·5

Fig. 143 represents these results in the form of curves, from which it would seem to result *inter alia* that amongst homologous soaps (stearic acid, palmitic acid, cokernut oil acids) the higher the molecular weight the less rapid the hydrolysis.

If extra alkali be added to the soap solution, the hydrolytic effect is proportionately weakened, as suggested by the character of these curves, concave downwards; thus the following figures were obtained with some of these same soaps:—

* Alder Wright and Thompson, *Journ. Soc. Chem. Ind.*, 1885, p. 625; Alder Wright, "Cantor Lectures," Society of Arts (*Journal Soc. Arts*, xxxiii., 1885, p. 1124).

Nature of Fatty Acids Used.	Extra Na ₂ O added to Solution, per 100 combined as Soap.	Hydrolysis brought about by x Molecules of Water.		
		$x = 50$	$x = 250$	$x = 5000$
Crude lauric acid (cokernut),	11.0	1.1	1.6	2.0
Cotton seed oil soap, .	15.0	nil.	nil.	6.5
Stearic and oleic (tallow),	20.0	nil.	nil.	nil.
Tallow rosin (primrose), .	15.0	nil.	0.1	1.3

The property of becoming hydrolysed by water has a great deal to do with the cleansing and detergent action of soap; the

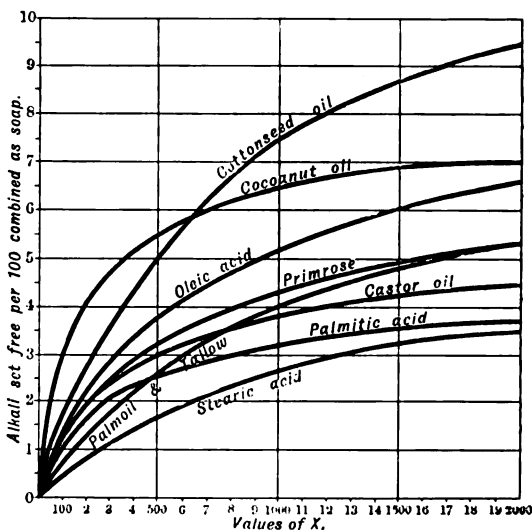
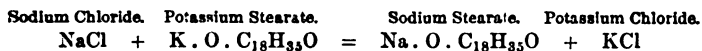

Fig. 143.

minute amount of alkali set free helps to emulsify greasy matters, and thus greatly facilitates their removal by washing out under friction.

Reaction of Soap Solution or of Fused Soap on Inorganic and other Salts.—When a solution of sodium chloride is added to one of a soda soap, or one of potassium carbonate to a potash soap, there being but one base present, obviously, no tendency can exist towards double decomposition and exchange of bases; but it is otherwise if sodium chloride be added to a potash soap, or potassium chloride to a soda soap; or if potassium carbonate be added to a soda soap or sodium carbonate to a potash soap. In certain of these cases it is well known that double decomposition ensues; thus, if a potash soap be made by

boiling fatty matter and wood ash ley together, and sodium chloride be then used to salt it out of solution, the resulting curd is largely composed of soda soap formed by the reaction (in the case of stearate).



In former days this reaction was utilised to prepare hard soaps in places where wood ashes only were obtainable as alkali (p. 473). Similarly, it has long been a practice to improve the softness and texture of soda soaps intended for toilet soapmaking by remelting and "pearlashing"—*i.e.*, adding to the melted soap potassium carbonate dissolved in a little water; the rationale of which has been shown to be* that double decomposition takes place with formation of potash soap and sodium carbonate, thus—

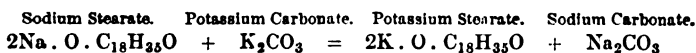

The presence of the potash soap makes the resulting mass less liable to crack during stamping, and also gives it better lathering qualities.

In these and all similar cases the general principle involved seems to be this. Potassium and sodium are so related that when both alkalis are simultaneously in presence of two acids, one weaker than the other, the potash tends to unite with the stronger acid and the soda with the other. Thus when stearic and hydrochloric acids are in question, the prevailing tendency is to form potassium chloride and sodium stearate, because hydrochloric acid is the stronger acid of the two; whilst when stearic and carbonic acids are the two acids, the chief tendency is to form potassium stearate and sodium carbonate, because stearic acid is a stronger acid than carbonic acid. As in most analogous cases, however, the question of relative masses is also concerned in the result; if these be suitably chosen the actions may to some extent be reversed—*e.g.*, if a large mass of potassium chloride act on a relatively small quantity of sodium stearate, a notable amount of soft potassium stearate is formed with a corresponding quantity of sodium chloride, in opposition to the above described actions occurring when the masses of potassium and sodium salts are not widely different. Similarly, if a relatively large amount of sodium carbonate acts on a small quantity of fused potash soap, a measurable amount of soda soap and a corresponding quantity of potassium carbonate are produced, notwithstanding the usual tendency to the opposite

* Alder Wright and Thompson, *Journ. Soc. Chem. Ind.*, 1885, p. 625.

change. Thus the following figures were obtained by Alder Wright and Thompson (*loc. cit. supra*):—

Fatty Acids Employed.	(a) Soda Soaps fused with K_2CO_3 . Percentage of total Fatty Acids present		(b) Potash Soaps fused with Na_2CO_3 . Percentage of total Fatty Acids present	
	Equivalent to the K_2CO_3 added.	Actually converted into Potash Soap.	Equivalent to the Na_2CO_3 added.	Actually converted into Soda Soap.
Stearic and oleic (tallow),	10.4	8.0
” ”	45.7	34.4
” ”	100.0	97.95	100.0	4.3
” ”	104.2	99.0	1000.0	15.0
Stearic, palmitic, and oleic (palm oil and tallow), }	57.2	52.1
” ”	108.0	90.8	177.0	9.5
Crude lauric acid (coker-nut oil), }	52.8	46.4
” ”	114.8	87.9	197.0	6.2
Crude ricinoleic acid (castor oil), }	50.0	48.4
” ”	100.0	93.8	205.0	8.2

Obviously the proportion of potassium carbonate converted into potash soap in the series (a) is uniformly much larger than the fraction of sodium carbonate converted into sodium soap in series (b)—*i.e.*, not far from the maximum possible in the first case, and only a few per cents. in the second; showing the much stronger tendency towards the first change than towards its converse.

In similar fashion the following figures were obtained on salting out potash soaps with sodium chloride, and soda soaps with potassium chloride; in series (a) *m* molecules of water were used to dissolve 1 of potash soap, and *n* molecules of sodium chloride added; in series (b) *m* molecules of water were added for 1 of soda soap, and *n* molecules of potassium chloride added:—

Fatty Acid Used.	<i>m.</i>	<i>n.</i>	(a) Potash Soaps salted out with NaCl. Percentage of Fatty Acid in Curd.		(b) Soda Soaps salted out with KCl. Percentage of Fatty Acid in Curd.	
			As Potash Soap.	As Soda Soap.	As Potash Soap.	As Soda Soap.
Stearic and oleic acids (tallow),	100	5	10.5	89.5	79.1	20.9
Stearic and oleic acids (tallow),	200	20	5.1	94.9	82.1	17.9
Stearic, palmitic, and oleic acids (palm oil & tallow),	200	20	3.8	96.2	95.8	4.2
Crude lauric acid (coker-nut oil),	200	20	5.4	94.6	74.8	25.2

Here the disproportion between the results in the (a) series and those in the (b) series is much less than in the case of carbonates, although it is still obvious that on the whole there is a greater tendency for sodium chloride to form a soda soap by acting on a potash soap, than for the converse reaction to occur.

The same result follows if a mixture of equivalent quantities of potash and soda soaps (obtained by halving the fatty acid, and neutralising one half with one alkali, and the other with the other) be dissolved in water and salted out with a mixture of equivalent quantities of potassium and sodium chlorides; a much larger proportion of soda soap is thus separated than is equivalent to the potash soap simultaneously thrown out of solution, the precise proportion varying with the nature of the fatty acids. Thus the following figures were obtained, indicating from 1.6 to 5.7 molecules of soda soap to 1 of potash soap:—

Fatty Acid Used.	Percentage of Fatty Acid contained.		Molecular Ratio of Soda Soap to Potash soap.
	As Potash Soap.	As Soda Soap.	
Pure oleic acid,	33.0	62.0	1.63 to 1
Crude ricinoleic acid (from castor oil),	17.8	82.2	4.6 to 1
Stearic, oleic, and rosin acids mixed (primrose soap),	17.2	82.8	4.8 to 1
Crude lauric acid (from cokernut oil soap),	15.1	85.9	5.7 to 1

It is remarkable that when only one acid is present, or a mixture of organic acids not greatly differing in strength, the proportion of soda and potash soaps formed by acting on a mixture of the two bases is sensibly the same as the proportion of the bases; thus with equal molecular quantities of potash and soda, and amounts of acid exactly equivalent to either of the alkalis separately, or to one-half of the two jointly, the following figures were obtained:—

Fatty Acids Employed.	Percentage of Total Fatty Acid converted into	
	Soda Soap.	Potash Soap.
Pure stearic acid,	51.2	48.8
„ oleic acid,	50.8	49.2
Crude stearic and oleic acids (tallow),	51.5	48.5
„ stearic, palmitic, and oleic acids (palm oil and tallow),	48.2	51.8
„ lauric acid (cokernut oil),	49.7	50.3
Mean,	50.3	49.7

In similar fashion, if a soda soap be melted and well inter-mixed with just as much caustic potash as is chemically equivalent to the soda present, or if a potash soap be similarly treated with the equivalent amount of caustic soda, the result in either case is the formation of a mixture of potash and soda soaps in practically equivalent quantities.

ANALYSIS OF SOAPS.

The general composition and character of soaps of different kinds being subject to considerable variation, the analytical determinations most useful in certain cases are not always those most valuable in other instances. Thus in the case of a fulling or woolscouring soap, freedom from excess of alkali or from alkaline salts (silicate, &c.) that might act injuriously on the wool fibre is the most important point, together with the proper nature of the fatty matters employed; whilst in the case of a laundry soap, freedom from excess of alkali is not at all an important condition, the presence of certain kinds of alkaline material (more especially alkaline carbonates) being generally beneficial rather than otherwise, *ceteris paribus*. In all cases, however, a highly important consideration is the proportion of actual soap present—*i.e.*, the proportion of the alkaline salts of fatty and resinous acids, apart from other saline matters, uncombined alkalies, unsaponified glycerides, water, glycerol, and substances added to give weight, or to increase the stiffness, or the detergent action, or for other reasons. An examination of the fatty acids set free on decomposition with a mineral acid is often useful, as giving information as to the nature and quality of the fatty matters originally employed; the first results being corrected, when necessary, by determining the amount of unsaponified fat present, and also the amount and general nature of unsaponifiable constituents, such as cholesterol, hydrocarbons, &c. Moreover, with certain kinds of medicated and disinfectant soaps the amount of active ingredient incorporated therein requires determination.

When the amount of total alkaline matter present (soda, or potash, or both) is known, expressed as anhydrous oxide (Na_2O , or K_2O) and also that portion which is "free"—*i.e.*, not combined with fatty and resinous acids, the difference obviously represents the combined alkali contained as actual soap: *i.e.*, if the percentage of "total alkali" (expressed as Na_2O) be a , and that of "free alkali" be b , $a - b$ is the percentage of "combined alkali." Similarly if c be the percentage of crude fatty acids, &c., obtained on decomposition with a mineral acid, whilst d is the percentage of unsaponified grease and unsaponifiable matters present therein admixed with the pure fatty acids, $c - d$ is the percentage of fatty acids contained combined as soap. The

weight of actual soap present then is $a - b + (c - d) - n$ per cent., where n is the amount to be subtracted in order to calculate fatty acids into fatty anhydrides (the soap being viewed for present purposes as made up of compounds of metallic oxides and the anhydrides of acids, such as Na_2O , $(\text{C}_{18}\text{H}_{35}\text{O})_2\text{O}$ for sodium stearate, and so on). Obviously, if the alkali be expressed as Na_2O , $n = \frac{9}{31}(a - b)$; whilst if it be expressed as K_2O , $n = \frac{9}{47.1}(a - b)$; so that in the first case the percentage of actual soap is—

$$a - b + (c - d) - \frac{9}{31}(a - b) = \frac{22}{31}(a - b) + (c - d)$$

and in the second case—

$$a - b + (c - d) - \frac{9}{47.1}(a - b) = \frac{38.1}{47.1}(a - b) + (c - d)$$

For instance, suppose that a soda soap gave the following results on analysis—

Crude mixture of fatty acids, &c.,	=	c	=	67.05 per cent.
Unaponifiable matters, &c.,	=	d	=	1.80 ,,
Fatty acids present in soap, .				
	=	$c - d$	=	65.24 ,,
Total alkali (expressed as Na_2O),	=	a	=	8.55 ,,
Free alkali	=	b	=	0.85 ,,
Combined alkali present in soap, =				
	=	$a - b$	=	7.70 ,,

Hence—
$$n = \frac{9}{31} \times 7.70 = 2.23$$

Whence the fatty anhydrides are	65.25	-	2.23	=	63.02
And the actual soap present	63.02	+	7.70	=	70.72

The analysis would then be stated thus—

Fatty anhydrides, . . .	63.02	per cent.	} Jointly = 70.72 per cent. of actual soap.
Combined alkali (Na_2O), . . .	7.70	,,	
Unaponifiable matters, &c.,	1.80	,,	
Water, free alkali, saline matters, &c. (by difference),	27.48	,,	{ Containing free alkali equivalent to 0.85 per cent. Na_2O , or $\frac{0.85}{7.70} = \text{about } \frac{1}{9}$ of the combined alkali.
	100.00		

In order, therefore, to determine the percentage of actual soap present, the four quantities a , b , c , and d must be determined; during the course of which analysis, the separate percentages of potash and soda may conveniently be also determined (when the two alkalies are simultaneously present); moreover, whilst c and d

are being separated from one another, the respective amounts of unsaponified glycerides and of unsaponifiable matters present in *d* may be conveniently determined, and further examinations made as to the characters of the separated and purified fatty acids, *c-d*, and of the unsaponifiable matters; in particular the proportion of rosin acids in the former may be determined, as also the melting point, &c., so as to obtain information as to the probable nature of the fatty matters used. This last point, however, is one where analytical data, as such, often fail to give satisfactory results—*i.e.*, the inspection of the mixed fatty acids and the valuation of their fusing points, &c., often leads to nothing definite; in some cases, however, the application of other tests (qualitative or quantitative) leads to useful results—*e.g.*, the elaidin test, &c.

The average molecular weight, *E*, of the fatty acids contained in the soap is frequently a datum of considerable value; this is readily deduced when *a*, *b*, *c*, and *d* are known, as shown on p. 172, being given by the equation—

$$E = \frac{c-d}{a-b} \times 31, \text{ when the alkali is expressed as Na}_2\text{O}$$

$$E = \frac{c-d}{a-b} \times 47.1 \quad \text{,,} \quad \text{,,} \quad \text{,,} \quad \text{K}_2\text{O}$$

Thus, in the above example, the value of *E* is—

$$\frac{65.25}{7.70} \times 31 = 263.$$

When required, the proportion of water present in the soap may be directly determined, as also any other constituents present, such, for example, as admixed weighting substances of mineral or organic nature (china clay, steatite, starch, sand, bran, &c.); saline matters (sodium chloride, sulphate, &c.); silica (from sodium silicate); glycerol; sugar; and so on.

In order to carry out a complete detailed analysis the following methods of procedure have been found convenient by the author,* the exact selection to be made varying with circumstances.

Water.—A convenient weight of an average sample of the soap cut up into thin shavings is dried, first at a temperature somewhat below 100° so as to avoid fusion, finally at 110°-120°. The loss of weight may be taken as water, especially when other volatile substances (carbolic acid, essential oils, &c.) are absent

* Various more or less similar methods and processes have been previously put forward by other chemists—*e.g.*, C. Hope, *Chemical News*, xliii. (1881), p. 219; Filsinger, *Chemiker Zeitung*, April, 1884; Allen, *Commercial Organic Analysis*, Second Edition, vol. ii., p. 251; Leeds, *Chemical News*, xlviii. (1885), p. 166; Alder Wright & Thompson, *Analyst* (1886), p. 44; &c.

or only present in small quantities. For many purposes this direct determination is one of the most important valuations, especially in conjunction with an estimation of free alkali (*e.g.*, in the case of soft soap). In other cases the direct determination is quite unnecessary, more particularly when the amount of actual soap present is determined, water and saline matters being conveniently taken by difference. Instead of reducing the soap to thin slices and drying without fusion, the amount of water may be arrived at by heating 5 or 10 grammes in a large porcelain crucible set in a sand bath, and stirring with a bit of glass rod (weighed with the crucible) until no more dew is deposited on a piece of glass placed over the crucible (the lamp being removed). When this stage is reached the water is practically all expelled, and a nearly constant weight attained. Care must be taken not to overheat and burn the soap; the glass rod should have a rough jagged end to facilitate the breaking up of clots.*

J. A. Wilson recommends † weighing out about 2·5 grammes of soap in a dish and dissolving in about 5 c.c. of absolute alcohol by means of heat; about 10 grammes of ignited sand are then added and the whole evaporated to dryness; the residue is again treated with 5 c.c. of absolute alcohol and evaporated and finally dried at 100° to 105° in an airbath. The addition of the sand facilitates the expulsion of water along with the alcohol, and renders it more easy to treat the dried soap in a Soxhlet apparatus for dissolving out unsaponified fat, &c.

Unsaponified Fat, Hydrocarbons, Spermaceti, Wax, &c.—5 (or preferably 10) grammes of soap are dried, first at 100° or below, and finally at 120°; or in a crucible, or with alcohol and sand as above: the residue is exhausted in a Soxhlet tube (p. 238) with light petroleum spirit; or a little spirit is poured on, allowed to digest, poured off (if necessary through a filter), and so on until all fat, &c., is dissolved out. Ether may also be used, but is more apt to dissolve out soap. The residue left on evaporation of the solvent may be examined as to its physical properties, and the saponifiable portion thereof determined by heating with excess of standard alcoholic potash, precisely as in determining the "total acid number" of an oil or fat (p. 157, *et seq.*) When saponification is complete (which may in some cases require an hour's boiling with a reflex condenser, or more) the unneutralised alkali is back-titrated: the exactly neutral fluid is then evaporated and the residue again treated with light petroleum spirit so as to dissolve out hydrocarbons, cholesterol or other alcoholiform saponification products, &c., obtained by evaporating the extract; whilst the undissolved portion on acidulation and shaking with ether enables the fatty acids, &c., produced by the saponification to be isolated for examination. In cases where

* Watson Smith, *Journ. Soc. Dyers and Colourists*, vol. i., p. 31.

† *Chemical News*, October 21, 1892, p. 200.

a full examination of the unsaponified fat, &c., is requisite it is preferable to employ a larger quantity (50 grammes or even 100) of soap, and not to combine this determination with that of water, &c., lost by drying. As a rule little but unsaponified glycerides are thus extracted; but "oleine" soaps often contain a small percentage of hydrocarbons contained in the oleine (distilled, p. 278), whilst if woolgrease have been used to adulterate tallow, notable amounts of cholesterol, &c., may be present. Spermaceti, vaseline, &c.,* may be present in special kinds of toilet soap; whilst certain laundry soaps are purposely intermixed with paraffin oil and similar hydrocarbons.

The unsaponified fat, &c., may also be isolated by dissolving the soap (which need not be dried) in hot alcohol and somewhat diluting with water; before complete cooling a little ether is dropped in (care being taken that no light is near to inflame ether vapour), which will generally prevent the mass gelatinising. More ether is added and the whole well agitated, and if separation does not occur, more water is added, the ethereal solution being finally drawn off by means of a separating funnel or Chattaway's tube (p. 120). The ethereal extract thus obtained usually contains soap, so that it should be evaporated and the residue dissolved in petroleum spirit and filtered. Some little amount of "dodging" is sometimes requisite to get the alcohol, ether, and water in the right proportions to bring about a proper separation into two fluids, one a watery alcoholic soap solution, the other an ethereal solution of fat, &c.

Fatty Anhydrides and Total Alkali.—The residue deprived of fat, &c., by petroleum spirit left in the Soxhlet tube as above, is dissolved in water † and decomposed by boiling with a slight excess of standard acid. On standing and cooling the fatty acids separate as a cake, which is washed, dried, and weighed, ‡

* When wax is present, toluene dissolves it out in the Soxhlet tube better than petroleum spirit (Schnaible).

† If mineral matters, &c., insoluble in alcohol are present, the soap may be treated (conveniently still in the Soxhlet tube) with alcohol, so as to dissolve out the soap, and leave the insoluble substances. In this case drying without addition of sand, &c., is preferable. The alcoholic extract may be evaporated to dryness and the residue weighed, so as directly to determine the "actual soap" present; or it may be diluted with hot water and treated with excess of standard acid, &c.

‡ Or the hot fluids may be washed into a separating funnel, the watery part run off, and the fluid fatty acids washed out on to a wet filter as in determining the Hehner number of an oil, &c. (p. 166). If particles of fatty acid adhere to the vessels either in this mode of operating or with the solid cake, they should be washed off with a little ether, &c., into a small beaker or basin, and the solvent evaporated, the rest of the fatty acids being subsequently added, and the whole weighed together after drying. When the soap contains any considerable amount of soluble fatty acids (e.g., when made from mixtures containing cokernut or palm kernel oil) these partly remain in the aqueous liquor from which they may be mostly extracted by shaking with ether.

and then subjected to such further tests as may be deemed necessary (melting point, elaidin test, &c.), more especially rosin acid determination (*infra*). If the fatty acids are very soft, or are derived from coker or palm kernel oil, a known weight (5 or 10 grammes) of beeswax or paraffin wax may be advantageously added before cooling so as to form a more solid cake, and to assist in dissolving out from the water the more soluble acids, due correction being made for the weight of added substance: this, however, obviously prevents any physical or other examination of the fatty acids after their being separated from the soap. If such an examination is not requisite it often saves time to weigh up a separate amount of average soap (10 grammes*) and without drying or treating with petroleum spirit to dissolve this in water, decompose with acid, and weigh the resulting mixture of fatty acids, unsaponified fat, &c., correcting the result by means of a separate determination of the latter quantity. The corrected percentage of fatty acids is calculated to fatty anhydrides as above described (p. 493).

When *nitric* acid is used as the standard acid, and the alkali employed for back-titration † is free from chloride and sulphate, the neutralised fluid may be divided into two halves for the determination of *sulphate* and *chloride* respectively; or, if requisite, a portion may be reserved for glycerol determination (*infra*).

From the amount of standard acid used, less that titrated in the liquid after removal of fatty acids, the total quantity of alkali present is known, including that present as soap, that contained as hydroxide or carbonate, and that present as other inorganic salts of alkaline reaction—*e.g.*, silicate.

* Instead of using 10 grammes of soap, a smaller quantity, say 2 grammes, may be dissolved in water, acidulated, shaken with ether in a well closed vessel, and the ethereal solution separated and evaporated; this method is preferable with soaps made from cokernut and palm kernel oils on account of the partial solubility of the fatty acids thence derived in water. In order to avoid loss of volatile acids during drying, the ethereal solution may be exactly neutralised with alcoholic solution of pure soda, evaporated to complete dryness, and weighed. By subtracting the Na_2O contained in the alcoholic soda from the weight of the pure soap (together with unsaponified grease and unsaponifiable matters) thus obtained, the weight of fatty anhydrides + unsaponified grease and unsaponifiable matters is known. The soda thus neutralised is the "combined alkali" (*vide infra*, "fatty acid titration test" for free alkali).

† Cochineal is a convenient indicator for the purpose. If any soluble organic acids are present in the watery fluid, they may be approximately estimated by first titrating with methyl orange as indicator, the colour change occurring when all the mineral acid present is neutralised; and then going on with addition of phenolphthalein, which is not reddened till the organic acids are neutralised. The additional alkali thus consumed may be calculated as *valeric acid*, $\text{C}_5\text{H}_{10}\text{O}_2$, in the case of soaps containing whale oils; or as *heptolic acid*, $\text{C}_7\text{H}_{14}\text{O}_2$, or *octoic acid*, $\text{C}_8\text{H}_{16}\text{O}_2$, in the case of cokernut oil soaps.

Free Alkali.—The term "free alkali" is generally understood as including the alkalinity of all substances present in soap possessing an alkaline reaction—i.e., the sum of the alkalinity due to hydroxide (caustic alkali), carbonate, and other salts such as silicate; so that the difference between the "total alkali" and the "free alkali" exactly represents the alkali combined with fatty and resinous acids as actual soap.

Excepting with freshly made soap, especially when preserved in large sized blocks, but little caustic alkali is ever found in commercial soap, because the absorption of carbon dioxide from the air is tolerably rapid; but the passage of that gas into the interior of a large mass, and to a lesser extent into the centre of an ordinary bar, is by no means instantaneous, so that the interior portion of a comparatively freshly made curd or hydrated soap (pp. 461, 470) often contains a notable amount of hydroxide. In order to distinguish the free alkali present as hydroxide from that contained in other forms, C. Hope* dissolves a known weight of an average sample in strong alcohol and filters; carbonate, silicate, &c., are left on the filter; whilst caustic alkali (whether potash or soda) passes through, dissolved in the alcohol along with the neutral soap. The operation may be conveniently carried out thus, constituting the "alcohol test" for free alkali. 5 grammes of undried average sample of soap are dissolved in hot alcohol free from all acidity or alkalinity, and as strong as possible) and the solution filtered through a hot water funnel: after completely washing out with alcohol, the undissolved residue is treated with water and the alkalinity determined. As a general rule, the alcoholic filtrate is neutral, but sometimes it is faintly acid to phenolphthalein; apparently with a slightly moist soap mass, absorption of carbonic acid from the air tends to develop a trace of "acid soap" (pp. 23, 486) with a corresponding quantity of alkaline carbonate: as this latter is undissolved by the alcohol it does not react on the acid soap during solution so as to neutralise it again.† In such a case the acidity ("negative alkalinity") of the alcoholic solution is determined, and the amount subtracted from the positive alkalinity of the residue. Thus 5 grammes of soap gave an alcoholic solution where the acidity represented 0.25 c.c. of seminormal alkali; whilst the residue neutralised 0.6 c.c. of seminormal acid: hence the "free alkali" is reckoned as $0.6 - 0.25 = 0.35$ c.c. of seminormal acid corresponding with 0.0054 gramme of soda (Na_2O) or 0.108 per cent.

Sometimes, on the other hand, the alcoholic filtrate is more or

* *Chemical News*, xliii. (1881), p. 219.

† With some kinds of soap, if a stream of pure carbon dioxide be passed through a hot clear filtered alcoholic solution of the soap, a slight visible precipitation of alkaline carbonate results, together with the formation of an equivalent amount of "acid soap."

less alkaline (through the presence of hydroxide in the soap); in which case the amount of alkali present in the filtrate is determined (using phenolphthalein as indicator) and *added* to that found in the residue, this method of operating being "Hope's test" in its original form. It has been pointed out by J. A. Wilson* that when caustic alkali is present in a soap which also contains unsaponified glycerides, the alcoholic alkaline solution is apt to act on these glycerides, diminishing the alkalinity by saponifying them, and so causing the amount of free alkali to be understated. The author has found that this source of error is readily avoided by cutting the soap to be examined into very thin slices or shavings, and exposing these loosely piled together in a small dish or beaker to the action of carbon dioxide, conveniently by placing the dish in a wide mouthed bottle filled with the gas, loosely corking it, and leaving the whole till next day. By that time all caustic alkali is carbonated, so that the alcohol test can be applied without any error due to saponification of glycerides, due correction being made, if requisite, for the "negative alkalinity" of the alcoholic filtrate caused by the action of the carbon dioxide forming small quantities of acid soap and alkaline carbonate. This mode of operating, however, obviously does not enable the relative amount of alkali to be distinguished present as hydroxide and carbonate, &c., respectively.

In the case of strongly alkaline soaps where a slight amount of error in determining the total amount of free alkali is not material, two other tests are applicable, respectively designated the "fatty acid titration test" and the "salting out test."† The first of these consists in determining the total alkali as above, separating the fatty acids, and titrating them, reckoning the difference as free alkali. In practice the unavoidable experimental error of this differential method is sometimes found to be sufficiently great to render the determination of minute quantities of free alkali decidedly uncertain, so that for nearly neutral soaps the method is useless. Moreover, the fatty acids separated by the action of dilute aqueous acid on soap are sometimes partly soluble in water, so that although the insoluble acids largely dissolve the soluble ones and bring them out of solution in water into the supernatant layer of fused fatty acids (as ether would dissolve out similar matters from watery solution), still a small proportion of the soluble acids are apt to be retained by the water and lost, thus tending to increase unduly the value of the free alkali determination; this is especially noticeable when cokernut or palm kernel oil has been employed in making the soap. When, however, the free alkali is large, so that a small

* *Chemical News*, lix. (1889), p. 280.

† Alder Wright and Thompson, *Journ. Soc. Chem. Ind.*, 1885, p. 625.

degree of possible error in its determination is not of great importance, this method is very convenient.

The "salting out test" is worked by dissolving a weighed quantity of soap in hot water, adding salt so as to throw the curd out of solution, filtering off, and titrating the alkali in the filtrate. This may be conveniently done in two fractions, one titrated directly so as to obtain the *total* alkali present (caustic + carbonated); the other treated with barium chloride in excess, and the *caustic* alkali determined present in the filtrate from the barium carbonate, &c., thus precipitated (*vide* p. 420, footnote). Apart from error in deficiency of the caustic alkali value thus deduced due to unavoidable absorption of carbon dioxide from the air during the operations, a source of error in excess is that hydrolysis of the soap examined necessarily takes place to an extent variable with the temperature, the quantity of water present relatively to the soap, the nature of the fatty acids present, and the amount of free alkali. When, however, a uniform mode of manipulating is adhered to, the results got with a given kind of soap are comparable amongst themselves, so that the figures obtained are often of considerable practical use, especially when corrected (by means of carefully made tests using the alcohol process) so as to get an approximate valuation of the excess of alkali due to the hydrolytic action. For instance, the following figures represent the difference in amount of free alkali found with a variety of soaps according as the alcohol test (A.T.) or salting out test (S.O.T.) was used: the numbers are reckoned per 100 parts of alkali combined with fatty acids as soap—*i.e.*, if the combined alkali = 10.0 and the free alkali = 0.52 per 100 of soap, this would correspond with 5.2 parts of free alkali per 100 of combined alkali:—

Nature of Soap Used.	A.T.	S.O.T.	Excess of S.O.T. over A.T.
Pure cokernut oil soap, not strongly alkaline,	5.0	9.1	4.1
Another sample of ditto,	2.8	5.8	3.0
A British toilet soap, largely made from cokernut oil,	1.3	5.8	4.5
A foreign toilet soap, largely made from cokernut oil (neutral),	0	3.5	3.5
A high-class American toilet soap,	1.8	5.4	3.6
A toilet soap largely made from lard (neutral),	0	3.2	3.2
A second-class ditto, chiefly made from tallow,	1.9	4.8	2.9
A cotton seed oil soap,	7.2	9.8	2.6
A tallow rosin (primrose),	1.1	3.0	1.9
A neutral castor oil soap,	0	1.7	1.7
A bleached palm oil soap,	5.0	6.4	1.4
A tolerably alkaline curd soap,	18.3	18.3	0
Pure stearic acid soda soap (neutral),	0	0.7	0.7

When the watery soap solution is tolerably concentrated (about 1 part by weight of actual anhydrous soap to 10 of water), and the soap itself contains a good deal of free alkali, the error due to hydrolysis becomes small enough to be quite negligible; but with a nearly neutral soap the hydrolytic error becomes several times as large as the free alkali actually present.

Potash and Soda.—When both alkalies are present, and it is required to determine their relative amount, several methods of operating are available. One of the simplest is to decompose a known quantity of soap with dilute hydrochloric acid, evaporate down the watery filtrate, convert potassium chloride into platinum-chloride, and weigh this. In the absence of more than minute quantities of sulphate, silicate, &c., the mixed alkaline chloride solution may be evaporated down and weighed, the chlorine contained determined (volumetrically or otherwise), and the ratio of potassium to sodium calculated from the indirect results. The soap may also conveniently be charred and the alkalies dissolved out from the ash for treatment. When much sulphate is present the alkalies should be weighed as sulphates and the indirect determination made by determining the barium sulphate yielded by the mixture.

Rosin Acids.—It is often of considerable importance to determine with some degree of approximate accuracy the proportion between the rosin acids and the ordinary fatty acids present in a given sample of soap. Several older methods have been proposed, none of which yield very accurate results; but more recently two processes have been introduced of a somewhat more satisfactory nature, although still leaving a good deal to be desired. The earlier of these is that of Gladding* based upon much the same principle as the ordinary separation of oleic and stearic acids, viz., conversion into metallic salts, one soluble in ether, the other insoluble. The soap to be tested is freed from unsaponified fat, &c., by treatment with petroleum spirit; or if glycerides only are present by heating with strong alcohol and a few drops of alcoholic potash in excess of the neutralising amount to effect complete saponification. The alcoholic soap solution is then agitated with powdered neutral silver nitrate and ether in a closed vessel for some time (0.5 gm. fatty acid, 1 gm. silver nitrate, and 100 c.c. of ethereal fluid altogether, answer well): after some minutes shaking flocculent silver stearate, &c., subsides, whilst silver resinate remains dissolved. A known fraction of the ether is siphoned off or removed by a "Chattaway tube" (p. 120) and agitated with dilute hydrochloric acid, whereby the silver is removed and an ethereal solution of rosin acids produced, by evaporating which the rosin acids are obtained in weighable form. Finally, a correction is made for the solubility of silver

* *Chemical News*, xlv. (1882), p. 159.

oleate, &c., amounting to a subtraction from the weight of rosin acids obtained of 23·5 milligrammes per 100 c.c. of ether.

A notable source of error in this method lies in the uncertainty of this correction, inasmuch as somewhat widely different values are found with different acids—*e.g.*,*

Nature of Fatty Matters in Soap Examined.	Fatty Matters Dissolved (as Silver Salt) in 100 c.c. of Alcoholic Ether.		
	Maximum.	Minimum.	General Average.
	Milligrammes.	Milligrammes.	Milligrammes.
Pure stearic acid,	16·0	8·0	11·6
„ oleic „	15·0	9·0	12·0
Nearly pure palmitic acid, .	30·0	28·0	29·1
Cotton seed oil,	34·0	20·0	26·9
Castor oil,	62·0	49·0	53·9
Cokernut oil (fatty acids dried on water bath),	17·5	12·0	14·8
Cokernut oil (fatty acids dried over H ₂ SO ₄),	23·0	19·0	21·1
Stearic and oleic acids, in nearly equal proportions, .	22·0	18·0	19·1
Stearic acid and cotton seed oil, in nearly equal proportions,	25·5
Oleic acid and cotton seed oil, in nearly equal proportions,	24·5
Stearic acid and cokernut oil (water bath), in nearly equal proportions,	23·4
Oleic acid and cokernut oil (water bath), in nearly equal proportions,	25·6

According to the nature of the fatty acids, the correction may thus vary between 8 and 62 milligrammes in the most extreme cases, and between 11·6 and 53·9 for average values, these quantities representing on 500 milligrammes of fatty acids respectively 2·3 and 10·8 per cent.; so that whilst 23·5 milligrammes (= 4·7 per cent.) is not far from a mean value, it is by no means equally applicable in all cases.†

* Alder Wright and Thompson, *Proceedings of the Chemical Society*, 1886, p. 175; also *Chemical News*, vol. liii. (1886), p. 165.

† Lewkowitsch has subsequently found still wider discrepancies between the corrections necessary in the case of stearic and oleic acids—*e.g.*,

	Correction per 100 c.c. of Alcoholic Ether.
Oleic acid,	109·0 to 109·4 milligrammes.
Stearic acid,	5·4 to 5·8 „

(*Journ. Soc. Chem. Ind.*, 1893, p. 503.)

Hubl and Stadler modify Gladding's process by precipitating the mixed silver salts from the largely diluted soap solution by means of aqueous silver nitrate, drying, and dissolving out silver resinates with ether in a Soxhlet tube (p. 238). Grittner and Szilazi add alcoholic calcium nitrate solution to the alcoholic soap solution to be tested, so as to remove most of

E. Twitchell's method* depends on the property of ordinary fatty acids to form compound ethers when dissolved in alcohol and treated with hydrochloric acid gas; if the alcohol be absolute and the solution saturated with the gas, the conversion is stated to be complete with fatty acids, whereas rosin acids are not acted upon at all; with alcohol of only 90 per cent., however, the action is not complete, several per cents. of the fatty acids escaping conversion. 2 or 3 grammes of mixed acids are dissolved in 10 volumes of absolute alcohol, and dry hydrochloric acid gas passed through for 45 minutes, the vessel being cooled by immersion in water; by and bye the fatty ethers separate, floating on the surface. After standing half an hour the mixture is diluted with five times its volume of water and boiled till clear, the ethers and rosin acids floating on the top; the whole is shaken with about 50 c.c. of light petroleum spirit; after separation, the hydrocarbon solution is washed by shaking with water, and finally shaken with 5 c.c. alcohol and 50 of water containing 0.5 gramme of caustic potash. The alkali dissolves out the rosin acids from the hydrocarbon, leaving the fatty ether still dissolved therein; on separation of the aqueous solution of resinate, and agitation with ether or petroleum spirit after acidulation, the rosin acids are obtained in solution, and may either be weighed (after evaporation to dryness) or titrated, assuming some particular value for their mean equivalent.† If glycerides are

the stearate, palmitate, and oleate present by precipitation; the filtrate is then treated with silver nitrate and ether as in Gladding's process. According to Lewkowitsch (*loc. cit. supra*) neither modification gives satisfactory results, the quantity of rosin found being generally *below* that actually present when soap made from known mixtures of fatty matters and rosin are examined as test samples. On the other hand, the figures obtained by means of Gladding's original process are generally *several per cents. too high*, even when the correction to be used has been separately determined for the particular fatty acids, &c., used for the test samples employed.

* *Analyst*, 1891, p. 169; also *Journ. Soc. Chem. Industry*, 1891, p. 804, from *Journ. Anal. and Applied Chem.*, vol. v., p. 379.

† Test experiments made by E. Twitchell showed that when the value 346, found as the mean equivalent weight of a sample of colophony, was used to calculate the result of titration of the rosin acids isolated from known mixtures of that colophony and fatty acids, the titration values always came out higher than those got by weighing; thus—

Volumetric.	Gravimetric.
21.40	...
20.36	...
19.91	...
Average 20.56	18.93

Hence apparently one or two per cents. of constituents were present, not of acid nature, and, consequently, not dissolved by the caustic potash and, therefore, not ultimately weighed along with the true rosin acids. Such constituents would be weighed along with the rosin acids isolated

present in the fatty acid mixture, this does not in any way invalidate the rosin determination, as the glycerides are not dissolved out by the alkaline liquor along with the rosin acids.

Silicate of Soda.—The substance left undissolved by alcohol in the determination of free alkali by the "alcohol test" (*supra*), after treatment of water and filtration, may be titrated for alkalinity and then evaporated to dryness with a slight excess of hydrochloric acid; the silicon dioxide formed in the event of silicate being present in the soap, is then left undissolved on treatment of the residue with water. Or a known weight of soap may be charred, and the ashes supersaturated with hydrochloric acid and thoroughly dried, so that silica and carbon are left undissolved by water, the latter being ultimately burnt off.

Starch, China Clay, Steatite, Pigments, &c.—Substances of this description other than colouring matters are not often found in soaps, but are occasionally added, especially to certain varieties of fancy soap—*e.g.*, "oatmeal" soap, certain so-called "milk" soaps, and the like. The residue from the previous examination for silicate and carbonate, &c., left undissolved by water on treating the matters insoluble in alcohol therewith consists of these substances. Ultramarine, chrome green, vermilion and similar pigments are sought after by the appropriate tests suggested by the colour; starchy matters by means of iodine; mineral constituents generally by incineration; and so on. The presence of such substances as oatmeal, farina, &c., sometimes renders it necessary to modify slightly the method for determining fatty acids above described, where the cake of fatty acids obtained is weighed, as it may contain some of these matters mechanically intermixed; to separate them the cake is dissolved in ether, benzene, &c., and filtered; the residue is well washed and the filtrate evaporated to dryness.

Glycerol and Sugar.—When glycerol is contained (as in the case of soft soaps, cold process soaps, hydrated soaps, &c.) it may be determined, with a fair degree of accuracy, in a variety

by Gladding's process. Lewkowitsch finds (*Journ. Soc. Chem. Ind.*, 1893, p. 505) that the mean equivalent* of different samples of commercial rosin varies within somewhat wide limits; thus, with six samples of American rosin values were found varying between 340.8 and 364, with an average of 348.3. Hence, the percentage of rosin found by titration can only be regarded as a somewhat rough approximation. On the other hand, Twitchell's process, applied to pure stearic acid and other fatty acids and mixtures free from rosin, indicated from 1.07 to 3.67 per cent. of that substance, the products obtained being weighed; whence it would seem that the quantity of rosin apparently found in a given sample of soap by Twitchell's process would be too high, and that a correction should be made to allow for this source of error (probably incomplete conversion of fatty acids into compound ethers, or subsequent decomposition of compound ethers). In practice, however, the quantity of rosin actually found is generally somewhat *below* that known to be present when test samples of known composition are examined.

of ways in the absence of sugar; but in presence of sugar its accurate determination is not easy. If sugar be not present, one of the simplest methods of procedure is to decompose the soap with a slight excess of sulphuric acid, and after separating the fatty acids to render neutral or slightly alkaline with sodium carbonate, evaporate to dryness, and dissolve out the glycerol from the sodium sulphate, &c., by absolute alcohol: the residue left on evaporating off the alcohol may be weighed, and any inorganic matters present determined by incineration and subtracted. The crude glycerol may, preferably, be purified as described on p. 523; or it may be converted into acetin by acetic anhydride (pp. 186, 516); or if sufficiently free from other organic substances it may be determined by the dichromate process (p. 522), or oxidised to oxalate (p. 519). A little glycerol is volatilised during the latter part of the evaporation; hence when either of these two latter methods is employed, instead of evaporating the aqueous solution to complete dryness, it may preferably be only partially concentrated. Muter's method consists in treating with copper sulphate and caustic soda, the copper kept in solution being determined colorimetrically or by potassium cyanide (p. 523), parallel observations being made with liquids treated in just the same way after addition of known quantities of glycerol solution from a burette, so as to afford the means of calculating the glycerol present from the amount of copper kept in solution. In general the glycerol may be thus estimated conveniently in the watery fluid left after determining total alkali and fatty acids (*supra*). When sugar is present this is inverted by heating with dilute hydrochloric or sulphuric acid; the liquid is then rendered alkaline and copper sulphate added in excess, and the sugar deduced from the amount of precipitated cuprous oxide; the alkaline liquid containing glycerol and the products of the oxidation of the sugar may be tested for glycerol by determining the amount of dissolved copper as before, checking the results by means of similar tests with liquids containing known quantities of sugar + glycerol; the results, however, are apt to be only approximate even with the greatest care. Instead of determining sugar by the copper reduction process the polariscope may be employed. Knowing the amount of sugar present and the specific gravity, the proportion of glycerol present may be approximately calculated in the case of a liquid containing no other substances in solution.

Volatile Substances other than Water.—Sometimes a transparent soap contains alcohol, the proportion of which is desired to be known; other volatile constituents are sometimes present in other kinds of soap—*e.g.*, carbolic acid, thymol, camphor, &c. In such cases special methods must usually be resorted to to determine the volatile substance, dependent on its nature. *Alcohol*, if in quantities above inconsiderable traces, may

be determined by dissolving in water a sufficient quantity of soap, adding salt, filtering off say one half of the total fluid, and distilling until about half has passed over; this distillate is similarly redistilled, and ultimately the quantity of alcohol inferred either from the specific gravity of the final distillate, or by oxidising with chromic acid, &c. The following method of determining *phenoloids* is recommended by A. H. Allen* :— 5 grammes of soap are dissolved in hot water, 20 to 30 c.c. of a 10 per cent. solution of caustic soda added, and the whole cooled and agitated with ether to dissolve hydrocarbons. The alkaline liquor is separated and treated with excess of strong brine; fatty acid soaps are precipitated, but sodium phenolate and cresylate, &c., remain in solution; the liquid is filtered and the precipitate washed with brine, and the filtrate and washings diluted to a litre. 100 c.c. of the solution (representing 0.5 gramme of soap) are acidulated with sulphuric acid, and the solution (clear if fatty acids have been thoroughly removed) titrated with bromine water standardised by means of carbolic acid (or cresylic, &c.), operating in the same way; when enough bromine has been added to cause all the phenoloids to become converted into tribromo derivatives, the yellow tint due to excess of bromine becomes visible. By treating the other 900 c.c. of solution with sulphuric acid and excess of bromine, and agitating with successive small quantities of carbon disulphide, the tribromo derivatives may be dissolved out and examined after evaporation of the solvent. Pure phenol (crystallised "carbolic acid") gives nearly colourless long needles of tribromophenol, whereas cresylic acids give deep yellow, orange, or red difficultly crystallisable or non-crystalline products; so that the character of the phenoloids present may be ascertained, as well as the amount.

The following general scheme represents a selection from the above processes applicable in most cases :—

Dry 10 grammes of *average sample*, finally at 120°, and reckon the loss of weight as *water*.

Exhaust the residue with light petroleum spirit, and examine the extract for *unsaponified glycerides, hydrocarbons, spermaceti, wax, cholesterol, &c.*

Treat the exhausted residue with water and excess of standard (nitric) acid; separate and weigh the *fatty acids*, and subject them to such further examination as may be required, more especially as regards the presence of *rosin acids*. Back-titrate the aqueous liquor so as to determine the *total alkali*, using alkaline solution free from sulphate and chloride. Determine *sulphate* and *chloride* in the neutralised liquid; also *glycerol* and *sugar* if present; and *potassium* if required.

Treat 5 grammes of *average sample* with hot strong alcohol, and titrate acidity or alkalinity of filtered solution: dissolve the

* *Commercial Organic Analysis*, 2nd edition, vol. ii., p. 255.

undissolved part in water and titrate for carbonated alkali, &c., so as ultimately to deduce the *free alkali*. Examine the substances not dissolved by alcohol for *silica, clay, starch, pigments,* and similar substances.* If unsaponified glycerides and caustic alkali be simultaneously present, the latter should be carbonated before dissolving the soap in alcohol, otherwise a deficiency in the total "free alkali" will result (*supra*, p. 499).

An objection to this mode of operation is that if any caustic alkali be contained in the soap, it becomes more or less carbonated during the drying, so that an incorrect valuation of caustic alkali results. When much caustic alkali is present, it may be determined by the salting out test (*supra*), adding barium chloride to convert alkaline carbonate into chloride, and filtering before titrating (compare p. 500).

Instead of decomposing the soap dissolved with alcohol with excess of standard acid, and back-titrating after separation of fatty acids, the alcoholic solution may be rendered neutral to phenolphthalein, and then directly titrated with a standard mineral acid solution, using methyl orange as an indicator, organic fatty acids having no reaction on this substance: perfectly sharp results are thus obtainable (Allen).

Cailletet's method of Analysis.†—For determinations where speed is indispensable but minute accuracy unnecessary, a convenient process has been proposed by Cailletet for the determination of fatty acids and alkali. A tube holding 50 c.c. and divided into 100 parts is provided, into which are introduced 10 c.c. of diluted sulphuric acid of known strength (about four times normal), 20 c.c. of oil of turpentine, and 10 grammes of the soap in shavings. The tube is closed with a stopper or cork and well shaken up; when all the soap is decomposed it is allowed to stand, and the volume of the turpentine solution of fatty acids read off. Subtracting the 20 c.c. of turpentine used, the difference gives the volume of the fatty acids: thus, if the turpentine solution occupied 50 divisions = 25 c.c., the fatty acids would represent $25 - 20 = 5$ c.c. per 10 grammes of soap. Assuming the specific gravity of the fatty acids to be n , their weight would be $5 \times n$ grammes = $50 \times n$ per cent. by weight. The alkali is obtainable by back-titrating the excess of acid.

Cailletet gives the following values for n in the case of soaps of different kinds, experimentally determined by noting the

* Instead of weighing up two portions of soap, one portion (preferably of 10 grammes) may be employed for all the determinations, being first dried, then exhausted with petroleum ether to extract fat, and then treated (still in the Soxhlet tube) with alcohol to dissolve out soap, glycerol, &c. The alcoholic extract thus obtained is titrated for acidity or alkalinity, then largely diluted with hot water and decomposed with standard acid so as to obtain fatty acids and total alkali; whilst the residue undissolved by alcohol is tested for alkali, silicate, sulphate, chloride, starch, pigments, &c.

† *Bulletin Soc. Ind.*, Mulhouse, xxix., p. 8.

increment in volume of turpentine oil as above indicated, and directly determining the percentage by weight of fatty acids in another portion of the same soap:—

	Specific Gravity of Fatty Acids.
Olive oil (Marseilles) soap,	0·9188
Cokernut oil soap,	0·9400
Palm oil soap,	0·9220
Tallow soap,	0·9714
Oleic acid soap,	0·9003

In the case of rosin soaps, the rosin acids do not readily dissolve in the turpentine, 20 c.c. only increasing 0·15 c.c. in volume by virtue of the rosin acids dissolved, whilst a bulky layer of undissolved rosin collects below the turpentine.

Calcium Salt Test.—A rough method of arriving at the value of a given soap is to dissolve in dilute alcohol and determine the quantity of the solution requisite to be added to a known volume of a solution of calcium chloride, sulphate, &c., so as to produce a permanent lather, as in Clark's test for the hardness of water; a parallel determination being made with a standard sample of similar soap of known composition, the ratio between the volumes of the two soap solutions used gives approximately their relative detergent value. The soap solutions may be conveniently made of the strength of 10 grammes per litre; the lime salt solution may be made by dissolving 0·2 gramme of pure calcium carbonate in dilute hydrochloric acid, evaporating to dryness on the water bath to expel excess of acid, dissolving the residue in distilled water and diluting to a litre; the solution consequently represents 20 milligrammes of CaCO_3 per 100 c.c. or 14 grains per gallon (14° of hardness on Clark's scale).

The following analyses represent the composition of a consider-

	Best Tal- low Curd, London make.	Bleached Palm Oil, London make.	Marine Soap, non- silicated.	Marine Soap, silicated.	Imitation Castile Soap, English.
Fatty anhydrides,	66·60	66·20	32·00	13·50	61·45
Combined alkali (Na_2O),	7·51	7·83	5·20	2·27	8·46
Free alkali (including that present as silicate),	·50	·40	2·25	8·36	1·16
Silica (SiO_2),	10·50	...
Sodium chloride,	1·35	2·05	7·65	5·05	1·17
Sodium sulphate,	·20	traces	1·45	·35	1·23
Water, carbonic acid, and insoluble matters, pig- ments, &c.,	23·84	23·52	51·45	59·97	26·53*
	100·00	100·00	100·00	100·00	100·00
Percentage of true soap, Mean molecular weight of fatty acids,	74·11 284	74·03 271	37·20 200	15·77 197	69·91 234

* Including 74 per cent. of insoluble pigments.

able variety of British and colonial manufacturers' and other scouring and laundry soaps. Where no analyst's name is mentioned, the analyses were made by the author.

	"Primrose," London make.	"Ivory," Canadian.*	"Cold Water," English.	"Cold Water," Canadian.*	Oleic Acid Soap, London make.
Fatty anhydrides, . . .	46.88	43.33	43.70	45.85	62.71
Resinous anhydrides, . . .	15.40	25.00	22.00	24.00	..
Combined alkali (Na ₂ O), . . .	7.12	7.72	9.28	8.00	7.36
Sodium carbonate,14	2.64	.58	2.22	.68
" chloride,14	} 21.31	} 24.44	} 19.93	} 29.25
" sulphate,07				
Water with minute quantities of insoluble matters, lime, ferric oxide, &c.,	30.25				
	100.00	100.00	100.00	100.00	100.00
Percentage of true soap, . . .	69.40	76.05	74.98	72.07	70.07
Free alkali (Na ₂ O),08	1.54	.34	1.30	.40
Mean molecular weight of fatty acids, &c.,	280	283	230	280	273

MANUFACTURERS' SOAPS (C. Hope).

	"Cold Water," Soap, Tallow, Rosin, and Cotton- seed Oil.	"Marseilles No. 1," chiefly Olive Oil.	"Palm Oil No. 1."	"Mottled" Palm Kernel Oil, Cold Process.	"Marine" for Use of Emigrants: Palm Kernel Oil, Cold Process.	"Pale Rosin," Tallow, and Rosin.
Fatty anhydrides and rosin, . . .	71.30	62.66	59.28	38.89	19.42	60.90
Soda (Na ₂ O), combined as soap, . . .	7.98	7.27	6.65	5.76	3.11	7.22
Free alkali (Na ₂ O), including carbonate and silicate, . . .	1.23	.80	.40	2.91	6.98	.10
Sodium chloride,36	.76	.47	1.78	5.13	.46
Sodium sulphate,30	.30	.13	.72	.35	.12
Silica, . . .	1.07	.06	.42	6.40	9.00	.04
Lime, oxide of iron, &c.,16	.16	.16	.03	.16	.02
Water, . . .	17.44	28.20	32.35	38.70	53.32	31.22
Total, . . .	99.84	100.21	99.86	95.19†	97.47†	100.08
Actual soap present, . . .	79.28	69.93	65.93	44.65	22.53	68.12

* Exhibited in the "Colonial and Indian Exhibition," London, 1886. For analyses of various of the Colonial soaps, made by the author, *vide* "Colonial and Indian Exhibition Reports—Oils and Fats" (Leopold Field).

† Glycerol present, but not determined.

MANUFACTURERS' SOAPS (*Lant Carpenter*).

	"Primrose" Soap.		"Cold Water" Soap.	"Neutral Curd."	"Oil" Soap. "Oleic Acid."
	Genuine Rosin Soap (South of England).	Watered Rosin Soap & Silicated (North of England).			
Fatty acids,*	62·3	42·66	70·2	67·9	68·6
Combined soda (Na ₂ O),	6·7	5·41	7·3	7·0	7·88
"Free alkali" (Na ₂ O),	...	1·21	1·8	nil.	1·0
Silica,	·94	1·6
Neutral salts,	·2	·55	·4	·2	1·0
Water,	32·8	50·40	22·0	28·0	21·0
Total,	102·0	101·17	103·3	103·1	99·48

PHARMACEUTICAL SOAPS (*M. Dechan*).

	<i>Sapo durus</i> , Hard Soap.	<i>S. Castil. albus</i> , White Castile.	Mottled Castile.	<i>S. Animalis</i> , Tallow Soap.	<i>S. Mollis</i> , Soft Soap.
Fatty acids,*	81·50	76·70	68·10	78·30	48·50
Combined alkali,	9·92	9·14	8·90	9·57	12·60
Free alkali,	·08	·09	·19	·28	·30
Silica,	·15	...	·17
Sulphates and chlorides,	·28	·36	·63	·47	·93
Matters insoluble in alcohol,	·50	·60	1·30	1·10	1·60
Other insoluble matter, .	·20	·90	·80	·40	1·00
Water,	10·65	13·25	21·70	12·50	39·50
	103·13	101·04	101·77	102·62	104·68

SOFT SOAPS (*Ure*).

	London Soft Soap.	Belgian Green Soap.	Scotch.	Rape Oil Soft Soap.	Olive Oil Soft Soap.
Fatty acids,	45·0	36·0	47·0	51·7	48·0
Dry potash (K ₂ O),	8·5	7·0	8·0	10·0	10·0
Water, salts, glycerol, &c.,	46·5	57·0	45·0	38·3	42·0
	100·0	100·0	100·0	100·0	100·0

In general, similar partial analyses of soft soaps meet the objects in view, inasmuch as such soaps are generally purchased in quantity under contract either to contain a given percentage (40, 50, &c.) of fatty acids producible on decomposition by a mineral acid, or to lose not more than a given percentage in weight (water) on drying completely; the degree of alkalinity is usually judged by the "touch" or taste of the sample, the tongue being regarded as a sufficiently delicate indicator for such purposes. When more definite information is required the methods

* Not calculated to fatty anhydrides.

above described are applicable; thus the water is directly determined by drying in a sand bath (p. 494); the total fatty acids, free alkali, combined alkali, unsaponified oil, and matters insoluble in water (such as starch added to simulate "figging," &c.) by the respective processes above detailed; the rosin acids by Gladding's process (p. 501) or Twitchell's method (p. 503); silicate by incineration and analysis of the mineral constituents of the ash; and so on.

In the case of household and laundry soaps it is to be noticed that the physical consistence of the substance is in many cases of as much importance as its chemical constitution. From the consumer's point of view what is required in the case of a hard soda soap is an article from which, during use, no more is dissolved or abraded than is just requisite for the object in view. If the soap be of too soft a consistency (either through over watering, or bad selection of materials), a much larger amount is rubbed on the clothes, &c., to be washed or scoured than is absolutely necessary, leading to much waste. On the other hand, pure tallow curd soaps largely boiled down are so hard as only to rub off and lather with difficulty. With manufacturers' soaps intended to be dissolved in water before use (*e.g.*, soft soap for wool scouring, &c.), the rate of solution must be sufficient for the purpose; whilst hydrocarbons and other insoluble impurities which might spot and stain goods must be absent from soaps intended for treatment during dyeing and subsequent operations.

TOILET SOAPS.

	High-class Milled Soap of Continental make.	High-class Opaque Soap, English.	Inferior Opaque Soap, English.	Transparent Soaps.		
				Made by Cold Process.	Made by Spirit Process.	
					Sugared.	Genuine, not Sugared.
Fatty anhydrides, .	83·60	60·20	65 00	38·90	65·60	68·10
Uncombined rosin and unsaponified fats,	1·00	·40	3·00	3·20
Combined alkali, .	9·80	6·98	8·91	5·57	7·73	7·62
Sodium carbonate,	·24	·17	1·73	3·80	nil.	·20
Sugar,	28·00	14·00	nil.
Glycerol,	3·00	6·00	3·00	...	7·00
Water and minute quantities of salts,	5·36	29·65	18·36	20·33	9·67	13·88
	100·00	100·00	100·00	100·00	100·00	100·00
Percentage of true soap,	93·40	67·18	73·91	44·47	73·33	75·72
Free alkali (Na ₂ O),	·14	·10	1·01	2·22	nil.	nil.
Mean molecular weight of fatty acids,	274	276	226	225	272	286

In the case of "toilet" soaps, the most important quality is that of furnishing a sufficient lather without at the same time causing the application of too alkaline a substance to the skin; the small amount of free alkali developed by hydrolysis when a tablet of soap is rubbed on the skin or between the hands is practically insensible, excepting to extremely sensitively skinned persons who, in consequence, are rarely able to use soap in any form without suffering more or less irritating effects. Such individuals are comparatively rare; but a much larger portion of the population, especially ladies and young children, are prone to suffer inconvenience (particularly in windy and wintry weather) through the use of soap containing more than traces of free alkali; to some extent this inconvenience may be mitigated by introducing into the soap such substances as vaseline, spermaceti, or even purified lard, &c., whereby a film of greasy or unguent-like substance is left adherent to the skin, or at least pressed into its pores (*vide* p. 478); but a far safer plan is so to prepare or refine the soap as to ensure that it shall not contain any material amount of free alkali. The author has proposed* to classify toilet soaps into three grades from this point of view, viz. :—

First grade.—Soaps containing a total amount of "free alkali" not exceeding $\frac{1}{40}$ (2·5 per 100) of the alkali present combined with fatty anhydrides as soap; so that if the soap contained 8·0 per cent. of combined alkali, the free alkali would not exceed 0·2 per cent.

Second grade.—Soaps where the "free alkali" ranges between $\frac{1}{40}$ and $\frac{3}{40}$ (2·5 to 7·5 per 100) of that present as actual soap—*i.e.*, for a soap containing 8·0 per cent. of combined alkali the free alkali would be between 0·2 and 0·6 per cent.

Third grade.—Soaps where the "free alkali" exceeds $\frac{3}{40}$ (7·5 per 100) of that present as actual soap.

It is to be borne in mind, however, that other possible ingredients besides alkali are apt to be detrimental to sensitive skins: of these *sugar* (almost invariably present in transparent soaps) is the one most certainly known to be noxious (pp. 478, 480, 482); but there is also reason for supposing that some extremely highly perfumed soaps may exert a more or less marked irritating action of the same kind in virtue of the comparatively high proportion of essential oils, &c., present (p. 480), even though entirely destitute of free alkali, and containing no sugar.

When a soap (toilet, household, or manufacturer's) contains an amount of glycerol approximately corresponding with that equivalent to the fatty acids found (92 parts glycerol for $3 \times n$ parts of fatty acids of mean molecular weight n), the probability

* "Cantor Lectures," Society of Arts, *Journ. Soc. Arts*, vol. xxxiii., p. 1121 (1885), where also various other analyses of toilet soaps are given.

is that the soap has been prepared by a cold process : such a soap, for instance, might yield fatty acids of mean molecular weight 270, in which case 100 parts of fatty acids would correspond with $\frac{92 \times 100}{3 \times 270} = 11.3$ parts of glycerol, if triglycerides were employed.

Larger proportions of glycerol can only be contained in cases where extra glycerol has been added. On the other hand, as soaps prepared by boiling and salting out contain no glycerol at all, the presence of smaller proportions of glycerol suggests either that the soap mass is a mixture of hydrated soaps or cold process soaps (Chap. xx.) and boiled soaps, or that free oleic acid, &c., has been employed along with glycerides in its manufacture.

CHAPTER XXII.

GLYCEROL EXTRACTION—MANUFACTURE OF GLYCERINE.

IN the manufacture of soaps and "stearine" for candlemaking, large quantities of glycerol* are produced as product complementary to the fatty acids formed by saponification of the oils and fats employed. Until comparatively recently, much of the glycerol thus formed was wasted, being run away along with other watery fluids into the drains, &c.; but since the introduction of various applications for which glycerol is suited, more especially the manufacture of dynamite and other explosives, much of the substance formerly thrown away as worthless, is now extracted and utilised by processes which substantially consist of evaporation so as to remove saline matters by crystallisation, and distillation with superheated steam of the final mother liquors.

The "sweet water" obtained in the saponification of glycerides by lime in the autoclave or open pan processes (pp. 365, 373), is one of the most eligible sources of commercial glycerine when required of high purity; the distillation of fatty matters by means of superheated steam, so as to hydrolyse them and form fatty acids and glycerol (p. 385), furnishes a still purer raw product; if the temperature of distillation be too high (above 310° to 320° C.), more or less decomposition of glycerol into water and acrolein (acrylic aldehyde) results.

The watery glycerol solutions thus obtained are concentrated

* As already stated (p. 110) the word "glycerol" is employed in the present work to denote the chemical substance $C_3H_8(OH)_3$, and the term "glycerine" to indicate commercial products more or less largely consisting of glycerol in varying states of purity.

by evaporation, preferably not in ordinary pans, but by special devices analogous to those used in the sugar industry, where a series of convoluted tubes or hollow plates heated by the internal admission of steam, are made to revolve, so that the tubes or plates partly dip into the fluid to be evaporated and carry upwards an adherent film thereof as they revolve, which film rapidly loses water by evaporation whilst the part of the tube or plate to which it adheres is exposed to the air after emerging from the liquid, especially if the whole arrangement is placed inside an exhausted vessel or "vacuum pan."

When the glycerol solution is sufficiently concentrated, it is decolorised by treatment with animal charcoal, and again distilled by means of superheated steam,* the processes being repeated several times for products of high purity, such as the glycerine required for the manufacture of nitroglycerine for dynamite and similar explosives. Glycerines of the highest degree of purity are best obtained by crystallising, draining off the unsolidified portion by a centrifugal machine, and melting the residual crystals.

The extraction and purification of glycerol from soap leys is a much more troublesome matter, not so much because of the dissolved salt, &c., which requires to be fished out as the evaporation proceeds, as because various organic impurities derived from the fats, &c., are also present. C. T. Kingzett † found the following compositions in the case of the salts deposited on evaporation, and of the evaporated mother liquor of specific gravity 1.236:—

SALTS.		
Sodium chloride,	.	78.12
Sodium sulphate,	.	8.61
Sodium carbonate,	.	2.61
Insoluble organic matter,	.	0.22
Glycerol and other organic soluble matters,	.	3.55
Water,	.	7.50
		100.61

CRUDE GLYCERINE.		
Water,	.	7.53 pounds per gallon.
Glycerol,	.	2.04 "
Salts,	.	2.78 "
		12.35 "

The removal of the inorganic salts and the saponaceous, resinous, and albuminous organic matters contained in the crude leys may be more or less completely effected in a variety of ways the subject of a number of patents. Thus, by acidulating the liquor any soap is decomposed, and fatty and resinous acids

* An improved form of glycerine rectifying apparatus has been patented by R. O. Unglaub (Eng. Pat., 8,196, 1889).

† *Journ. Soc. Chem. Ind.*, 1882, p. 77.

set free, separable by filtration. By treating with carbon dioxide any caustic alkali is carbonated, and its removal by salting out on evaporation rendered more easy (*Versmann*). By adding tannin in some form or other, albuminous matters may be coagulated and precipitated (*Payne*). The substitution of sodium sulphate for common salt in the salting out process is said to facilitate the separation of saline matters on evaporation, and the remaining sodium sulphate finally remaining to interfere less with the purification by distillation, ultimately necessary to render the glycerol suitable for most of the purposes for which it is employed (*Benno, Jappé, & Co.*) Spent leys produced when black ash liquors are directly used for soapmaking, contain a variety of impurities not present when purer caustic soda is used, especially that made by the ammonia process; such liquors may be considerably purified by the addition of soluble copper salts, whereby sulphocyanides and organic matters, &c., are precipitated (*Allen and Nickels*).

A few years ago the Michaud-Frères process for saponifying glycerides with zinc oxide (p. 379) instead of lime, attracted considerable attention, it being expected that fatty acids and glycerol would be so readily obtained that the older soap boiling processes would be superseded, and direct neutralisation processes (p. 451) substituted for them, whilst almost pure glycerol would result, as in the candlemaking lime autoclave process. As yet, however, this result has not been brought about to such an extent as seriously to interfere with the older soapmaking processes. A similar remark applies to methods based on saponification with ammonia solution under pressure (p. 379).

Commercial glycerines often contain impurities of various descriptions best estimated by direct determination. Lime, lead, magnesia, saline matters, and similar nonvolatile substances are left behind on evaporation and incineration, and may be examined in the ordinary ways; distilled glycerines only contain minute amounts of inorganic matter, rarely exceeding 0.1 to 0.2 per cent. Silver nitrate forms no precipitate or darkening in colour after standing 24 hours when added to glycerines free from acrolein, formic acid, or other substances capable of reducing silver salts, but blackens considerably in their presence.* Traces of chlorides will not precipitate silver nitrate, silver chloride being slightly soluble in glycerol; glycerines from soap leys, however, give copious precipitates, as they usually contain several per cents. of sodium chloride. Such leys often contain *resinous matters, albuminoids, fatty acids*, and other substances precipitable by basic lead acetate. Cane sugar and glucose are sometimes added as adulterations, easily detected by the cuprous oxide (*Fehling's*)

* According to *Ritsert*, pure glycerol gives neither deposit of metallic silver, nor formation of yellow colour, when mixed with its own volume of ammonia solution, heated to boiling, and treated with silver nitrate.

test. Glycerol intended for dynamite manufacture should be wholly free from organic impurities, because the action of nitric acid thereon during nitration might seriously endanger the success of the process and the stability of the product. Chlorides, except in the merest traces, should similarly be absent; whilst other inorganic matters (lime, &c.) should only be present in traces.

Estimation of Glycerol in Watery Solutions.—For the qualitative detection of glycerol in aqueous solution a variety of tests have been proposed, one of which (Reichl's) is described on p. 8. Kohn* recommends the following method:—The liquid to be examined is evaporated with acid potassium sulphate and the residue heated in a retort; if glycerol is present, acrolein is formed, so that the distillate gives a red coloration on treatment with a solution of rosaniline that has been just decolorised by sulphurous acid.

Several processes have also been proposed for the quantitative determination of glycerol, some of which are only suitable under particular conditions: thus in the case of distilled glycerines of considerable or tolerable purity where organic matters are absent and inorganic constituents and water are the only impurities (no adulteration with glucose or other sugar, &c., being present), the amount of glycerol may be conveniently ascertained by oxidation with potassium dichromate and sulphuric acid, either collecting the carbon dioxide formed, or determining the dichromate reduced by using a known quantity and back-titrating with a standard iron solution.† Another method applicable under such conditions is the "acetin process" of Benedikt (p. 186), where the substance is heated with excess of acetic anhydride and anhydrous sodium acetate, and the weight of potash (KOH = 56.1) determined, neutralised by the acetic acid formed on saponification of the triacetin produced (after destroying the excess of acetic anhydride by boiling with water).‡ 92 parts of glycerol correspond with $3 \times 56.1 = 168.3$ parts of KOH thus neutralised. Weak glycerol solutions must be evaporated down until at least 50 per cent. of glycerol is present in the fluid.

Two physical methods are applicable in the case of glycerol solutions where no appreciable amount of interfering impurity is present, so that practically only glycerol and water are contained; these are based respectively on the determination of the specific gravity at 15°, and of the refractive index at the same temperature.

Skalweit gives the following table§ for the purpose of examining glycerol solutions in these ways: older tables have also

* *Journ. Soc. Chem. Ind.*, 1890, p. 148.

† For comparative results of various modes of testing commercial glycerines, vide O. Hehner, *Journ. Soc. Chem. Ind.*, 1889, p. 4.

‡ According to Hehner (*loc. cit.*) the liquid must *not* be boiled, as the triacetin rapidly hydrolyses.

§ *Repert. Analyt. Chemie*, v., 18.

been given by Strohm^{*} and Lenz,[†] reproduced by Benedikt.[‡] Hehner (*loc. cit. supra*) considers Lenz's table accurate, and Richmond has recalculated it to 15°·5 C.

SPECIFIC GRAVITY AT 15°·5 (*Lenz, recalculated by Richmond*).

Percentage of Glycerol.	Specific Gravity at 15°·5.	Percentage of Glycerol.	Specific Gravity at 15°·5.
100	1·2674	87	1·2327
99	1·2647	86	1·2301
98	1·2620	85	1·2274
97	1·2594	84	1·2248
96	1·2567	83	1·2222
95	1·2540	82	1·2196
94	1·2513	81	1·2169
93	1·2486	80	1·2143
92	1·2460	79	1·2117
91	1·2433	78	1·2090
90	1·2406	77	1·2064
89	1·2380	76	1·2037
88	1·2353	75	1·2011

SPECIFIC GRAVITY AND REFRACTIVE INDEX OF GLYCEROL SOLUTIONS (*Skalweit*).

Percentage of Glycerol.	Specific Gravity at 15° C.	Refractive Index for D at 15° C.	Percentage of Glycerol	Specific Gravity at 15° C.	Refractive Index for D at 15° C.
100	1·2650	1·4742	50	1·1290	1·3996
98	1·2600	1·4712	48	1·1236	1·3966
96	1·2550	1·4684	46	1·1182	1·3938
94	1·2499	1·4655	44	1·1128	1·3910
92	1·2447	1·4625	42	1·1074	1·3882
90	1·2395	1·4595	40	1·1020	1·3854
88	1·2341	1·4565	38	1·0966	1·3827
86	1·2287	1·4535	36	1·0912	1·3799
84	1·2233	1·4505	34	1·0858	1·3771
82	1·2179	1·4475	32	1·0804	1·3743
80	1·2125	1·4444	30	1·0750	1·3715
78	1·2071	1·4414	28	1·0698	1·3687
76	1·2017	1·4384	26	1·0646	1·3660
74	1·1963	1·4354	24	1·0594	1·3633
72	1·1909	1·4324	22	1·0542	1·3607
70	1·1855	1·4295	20	1·0490	1·3581
68	1·1799	1·4265	18	1·0440	1·3555
66	1·1743	1·4235	16	1·0390	1·3529
64	1·1686	1·4205	14	1·0340	1·3503
62	1·1628	1·4175	12	1·0290	1·3477
60	1·1570	1·4144	10	1·0240	1·3452
58	1·1514	1·4104	8	1·0192	1·3426
56	1·1458	1·4084	6	1·0144	1·3402
54	1·1402	1·4054	4	1·0096	1·3378
52	1·1346	1·4024	2	1·0048	1·3354

^{*} *Monatsh. für Chemie*, v., 61. [†] *Zeitsch. f. Analyt. Chemie*, xix., 302.
[‡] *Analyse der Fette*, 2nd edition, p. 256, *et seq.*

Another physical process is also available for such fluids as the comparatively pure solutions of glycerol obtained in the

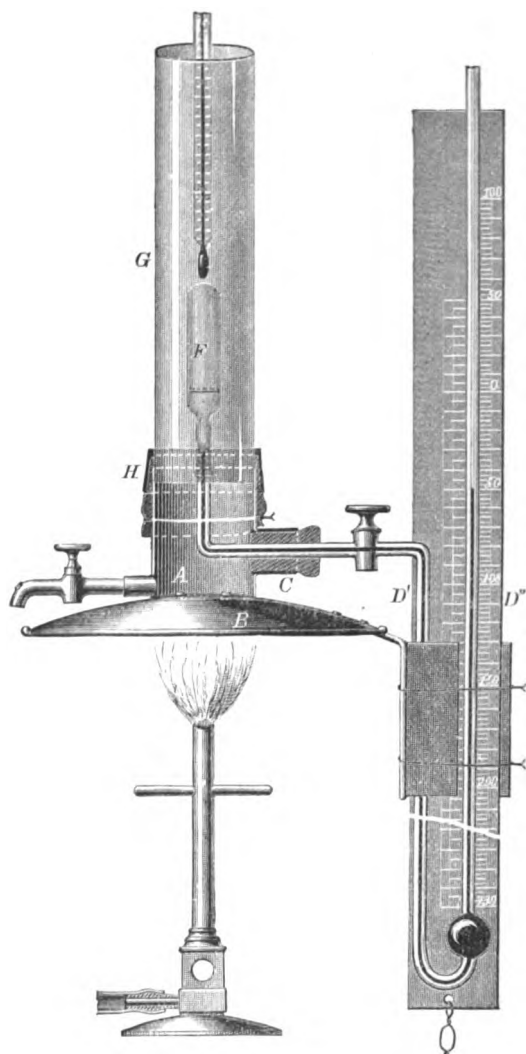

Fig. 144.

course of preparing candle materials (autoclave "sweet waters"), or for distilled glycerines retaining only small quantities of

impurities ; this is based on the differences in the tension of the vapour emitted by glycerol solutions of various degrees of concentration. Gerlach's vaporimeter for this purpose is represented by Fig. 144. A B is a hollow metal cylinder with dished bottom for heating ; G a glass cylinder fitting therein and made watertight by the indiarubber ring, H. To use the instrument, G is disconnected and the whole turned upside-down ; the reservoir, F, filled with mercury and a little of the fluid to be examined, is then connected by a bit of rubber tubing to the end of the pressure tube, D D, passing inwards through the tubulus, C. The instrument is then erected, and filled with hot water after fixing G in position, the temperature being then raised to boiling by heating B. The expansion of the mercury on heating and the further expulsion thereof by the vapour emitted from the glycerol solution fill the pressure tube, D D, with mercury up to a given level : the length in millimetres of the level-difference between the mercury in the reservoir and that in the open limb of the pressure tube (known by means of the attached scales) represents the difference between the tension of aqueous vapour emitted from pure water (equal to the existing barometric pressure) and that of the vapour emitted by the glycerol solution : from this the percentage of glycerol is reckoned by means of the table on next page.

When organic substances are absent capable of forming oxalic acid under the influence of alkaline permanganate, moderately sharp valuations may be obtained by converting the glycerol into oxalate (Wanklyn and Fox ; Benedikt and Zsigmondy ; A. H. Allen). The liquid is rendered strongly alkaline and boiled with excess of permanganate ; this is destroyed by sodium sulphite or sulphur dioxide and the liquid filtered and precipitated as calcium oxalate.

When this process is applied to the determination of the amount of glycerol furnished on saponification by a given oil or fat, the preliminary saponification should be effected by means of caustic potash and pure methylic alcohol ; the solution obtained by treating 2 to 3 grammes of oil is evaporated and the residue treated with hot water and dilute hydrochloric acid : a little solid paraffin wax may conveniently be added to help the solidification of liquid fatty acids on cooling. The whole is filtered and washed, neutralised with potash and about 10 grammes more potash added ; enough 5 per cent. potassium permanganate solution (or the powdered salt) is then added to render the fluid no longer green, but blue or blackish : the whole is then heated to boiling whereby hydrated manganese dioxide separates, the liquid becoming red ; aqueous sulphurous acid is then added till decolorisation is produced, and the whole filtered : the filtrate is acidulated with acetic acid (whereby any turbidity due to passage of manganese dioxide through the filter is removed

by the action of the sulphurous acid set free) and the oxalic acid present precipitated by calcium chloride or acetate; the calcium oxalate is ignited, dissolved in excess of seminormal acid and back-titrated with seminormal alkali, using methyl orange as indicator. 1 c.c. of *normal* acid (2 c.c. of seminormal) corresponds with 46 milligrammes of glycerine.

Percentage of Glycerol.	Specific Gravity of Solution.		Boiling Point of Solution.	Tension of Vapour emitted at 100°.	Diminution in Tension Compared with Water giving 760 Millimetres.
	At 15°. Water at 15° = L.	At 20°. Water at 20° = L.			
100	1·2653	1·2620	Degrees C. 290	64	696
99	1·2628	1·2594	239	87	673
98	1·2602	1·2568	208	107	653
97	1·2577	1·2542	188	126	634
96	1·2552	1·2516	175	144	616
95	1·2526	1·2490	164	162	698
94	1·2501	1·2464	156	180	580
93	1·2476	1·2438	150	198	562
92	1·2451	1·2412	145	215	545
91	1·2425	1·2386	141	231	529
90	1·2400	1·2360	138	247	513
89	1·2373	1·2333	135	263	497
88	1·2346	1·2306	132·5	279	481
87	1·2319	1·2279	130·5	295	465
86	1·2292	1·2252	129	311	449
85	1·2265	1·2225	127·5	326	434
84	1·2238	1·2198	126	340	420
83	1·2211	1·2171	124·5	355	405
82	1·2184	1·2144	123	370	390
81	1·2157	1·2117	122	384	376
80	1·2130	1·2090	121	396	364
79	1·2102	1·2063	120	408	352
78	1·2074	1·2036	119·0	419	341
77	1·2046	1·2009	118·2	430	330
76	1·2018	1·1982	117·4	440	320
75	1·1990	1·1955	116·7	450	310
74	1·1962	1·1928	116	460	300
73	1·1934	1·1901	115·4	470	290
72	1·1906	1·1874	114·8	480	280
71	1·1878	1·1847	114·2	489	271
70	1·1850	1·1820	113·6	496	264
65	1·1710	1·1685	111·3	533	227
60	1·1570	1·1550	109	565	195
55	1·1430	1·1415	107·5	593	167
50	1·1290	1·1280	106	618	142
45	1·1155	1·1145	105	639	121
40	1·1020	1·1010	104	657	103
35	1·0885	1·0875	103·4	675	85
30	1·0750	1·0740	102·8	690	70
25	1·0620	1·0610	102·3	704	56
20	1·0490	1·0480	101·8	717	43
10	1·0245	1·0235	100·9	740	20
0	1·0000	1·0000	100·0	760	0

The quantity of glycerol thus found is close to, but generally a little below, that deduced from the saponification equivalent of the substance on the assumption that only triglycerides are present.* In the case of oxidised drying oils, however, a notable excess is observed, doubtless on account of the formation of other products yielding oxalic acid by oxidation. Thus Benedikt and Zsigmondy obtained the following values:—

Name of Oil, &c.	Glycerol calculated from the Saponification Equivalent.	Glycerol found by Oxalic Acid Process.
Olive oil,	10.49 to 11.10	10.15 to 10.38
Coker butter,	14.76 to 14.83	13.3 to 14.5
Tallow,	10.72	9.94 to 10.21
Cows' butter fat,	12.51	11.59
Linseed oil,	10.24 to 10.66	9.45 to 9.97
Skins from boiled linseed oil,	15.5 (Allen)

The following table exhibits the amounts of glycerol theoretically obtainable from 100 parts of the triglycerides of the respective acids named; the last column indicates the amount of fatty acid simultaneously produced:—

Glyceride of	Formula of Acid.	Percentage of Glycerol.	Percentage of Fatty Acid.
Butyric acid,	$C_{14}H_{28}O_2$	30.5	87.41
Lauric ,,	$C_{12}H_{24}O_2$	14.4	94.04
Myristic ,,	$C_{14}H_{28}O_2$	12.7	94.47
Palmitic ,,	$C_{16}H_{32}O_2$	11.42	95.28
Stearic ,,	$C_{18}H_{36}O_2$	10.34	95.73
Oleic ,,	$C_{18}H_{34}O_2$	10.41	95.70
Ricinoleic,,	$C_{18}H_{34}O_3$	9.98	95.92
Linolic ,,	$C_{18}H_{32}O_2$	10.48	95.67

In the case of the higher acids the sum of the glycerol and fatty acids is approximately constant—viz., 106 to 107 per 100 of glyceride used.

C. Mangold † modifies the oxalic acid process by dissolving 0.4 gramme of the glycerine to be tested in 300 c.c. of water containing 10 grammes caustic potash, and adding 55 c.c. of a 5 per cent. solution of potassium permanganate. After standing half an hour hydrogen peroxide solution is added until all manganese is precipitated. A known fraction of the total fluid

* If E is the mean saponification equivalent of a mixture of triglycerides, 3E milligrammes of the mixture theoretically yield 92 of glycerol = $\frac{92}{3E} \times 100$, or $\frac{3065.7}{E}$ per cent.

† *Zeits. angew. Chem.*, 1891, p. 400.

is filtered off, boiled for half an hour to destroy excess of hydrogen peroxide, acidulated with sulphuric acid after cooling, and titrated with permanganate so as to determine the oxalic acid produced.

David recommends the following process for determining the amount of glycerol formed on saponification. 100 grammes of fat are heated with 65 of crystallised barium hydrate, and 80 c.c. of 95 per cent. alcohol added with agitation. The nearly solid mass is boiled with 500 c.c. of water and allowed to settle; the residue left on pouring off the supernatant fluid is washed twice by decantation, and the total fluid evaporated to half its bulk with sulphuric acid, the surplus being removed by barium carbonate. Finally the filtered fluid is evaporated to 50 c.c. and examined either as to its refractive power or as to its specific gravity, the amount of glycerol being deducible by means of the table given on p. 517.

According to *Hehner (loc. cit. supra)* the bichromate process (p. 516) gives sufficiently accurate results for practical purposes with fats and soaps when thus carried out; the fat is saponified with alcoholic potash (about 3 grammes being used) and diluted to about 200 c.c.; the fatty acids are separated by means of dilute sulphuric acid and filtered off; the filtrate is boiled down to half its bulk and treated with sulphuric acid and dichromate; Obviously if any traces of alcohol are left in the fluid, or if soluble acids or other organic matters capable of reducing dichromate are present, the results will come out too high. Operating in this way *Hehner* obtained the following percentages of glycerol:—

Olive oil,	10·26	per cent.
Cod liver oil,	9·87	„
Linseed oil,	10·24	„
Margarine,	10·01	„
Butter fat,	11·96 to 12·4	„

When chlorides or aldehydic matters are present (*e.g.*, acrolein in distilled glycerines) the glycerol solution is first treated with silver oxide, being slightly diluted and warmed therewith in a flask; basic lead acetate is then added in slight excess, the fluid made up to a known bulk, and an aliquot part filtered off through a dry filter and treated with dichromate.

Glycerol in Soap Leys.—On account of the organic impurities present in soap leys along with large amounts of inorganic salts, the above methods, as a rule, are not directly available for the estimation of glycerol in such liquors. By evaporation these may be concentrated without material loss of glycerol at first, although subsequently a perceptible amount is carried away with the escaping water vapour as the liquors become highly concentrated. When the evaporation is carried

nearly to dryness a residue is obtained from which nearly absolute alcohol dissolves out glycerol along with more or less inorganic matter; a rough estimate of the glycerol present is obtainable by evaporating the alcoholic solution to dryness and weighing, and then gently incinerating so as to burn off organic matter, the weight of ash left being deducted from that of the total residue. If, however, other organic matters soluble in alcohol be present, obviously they would thus be reckoned as glycerol; in some cases a partial purification of the glycerol may be brought about by again evaporating the alcoholic extract, treating the residue with a small quantity of absolute alcohol, and then adding one and a-half times the volume of ether; glycerol is kept in solution, but some of the other organic matters are usually precipitated, so that a partial purification is brought about. In other cases the crude glycerol may be purified by treatment with neutral or basic lead acetate to precipitate colouring matters, &c. When rosin is present in the liquors they may be conveniently purified by evaporating down after neutralising with dilute sulphuric and adding a little milk of lime (whereby most of the rosin is converted into insoluble lime salt) and filtering; the residue is treated with a mixture of three volumes absolute alcohol and one of pure ether, the dissolved matter weighed (after expulsion of the solvent) and corrected for ash left on incineration (*Fleming*).

Another process (*Muter's*)* consists in heating the crude glycerol liquors with basic lead acetate to remove certain kinds of organic matters that would interfere with the subsequent part of the test, filtering and removing the lead by sulphuretted hydrogen, and then treating with caustic soda or potash, and dropping in copper sulphate solution with continuous agitation until copper hydroxide remains permanently undissolved; the quantity of copper contained in the blue solution is about proportionate to the amount of glycerol present (under certain conditions—*vide infra*), so that by determining the dissolved copper the glycerol is known. For this purpose *Muter* employs a standard solution of potassium cyanide, for which the author has substituted a colorimetric process based on comparison of the hue of the tinted fluid (filtered) with that of a known relative thickness of copper solution containing a known amount of copper also dissolved in glycerol solution under the same conditions.†

Unless the proportion of caustic alkali present is uniform, a measurable difference in the solvent power of glycerol for copper hydroxide is noticeable, as the amount of alkali varies (*Puls*); so that when a cyanide solution is used it should be standardised

* *Analyst*, 1881, p. 41.

† *Alder Wright*, "Cantor Lectures," *Society of Arts Journal*, 1885, xxxiii., p. 1123.

by means of a known glycerol copper solution prepared side by side with the substance examined in exactly the same way.

Crude glycerol solution, purified by basic lead acetate, usually retains but little of any organic matters of an alcoholiform or hydroxylated character, so that the acetin method (*supra*) can generally be applied without serious error to the residue left on evaporation and extraction with alcohol. This, however, is not so certainly the case as regards the oxalate method, there being a possibility of obtaining oxalate by the oxidation of organic matters other than glycerol; whilst the dichromate process is usually inapplicable, organic impurities being generally still left which readily reduce dichromate.

A method sometimes employed is to heat a quantity of crude glycerine, representing about 2 grammes of glycerol, with 40 grammes of litharge to about 130°, taking care that no carbonic acid gets access to the mass; when the weight becomes constant the whole is similarly heated to 160°, at which temperature the glycerol is volatilised excepting that a molecule of water remains behind combined with the lead oxide, so that the loss of weight is $\frac{74}{92}$ times the glycerol present; hence the loss of weight at

160° multiplied by $\frac{92}{74} = 1.243$ represents the glycerol present.

With glycerol containing resinous matter it is impracticable to expel all the glycerol at 160°; whilst if chlorides or sulphates of alkali metals are present these react on the lead oxide forming hydroxides which readily absorb carbonic acid (Hehner).

INDEX.

- A**
- ABBÉ, refractive index, 51.
- Abel, flashing point apparatus, 126.
- Absolute measure, determination of viscosity in, 107.
- Absorption of oxygen by fatty acids, 113.
- " " by oils, 42, 125, 129-137, 318, 341.
- " " during cod liver oil extraction, prevention of, 248.
- " " quickened by boiling, 129, 313.
- " " test for lubricating oils, 134, 330.
- " " *See also* Oils (blown), Oils (drying), Gumming.
- " " spectrum, 50.
- Acajou—*see* Oil (cashewnut).
- Accumulators—*see* Hydraulic presses.
- Acetic anhydride, action on acids from Turkey red oils, 335.
- " " action on alcohols, glycerol, &c., 8, 13, 186, 191.
- " " action on cholesterol and allied bodies, 17, 191.
- " " action on hydroxylated acids, 35, 37, 41, 186-191.
- " " action on non-hydroxylated acids, 189-191.
- " " action on cenanthol, 25.
- Acetyl acid number (acetyl saponification number), 187.
- Acetyl number, titration; acetyl number, distillation, 198.
- Acetylation test (acetyl test, acetyl number), 17, 43, 121, 129, 157, 341.
- " " process of working, 186-191.
- " " process of working, Lewkowitsch's distillation modification, 190, 198.
- Acetylation test, use of, in analysis of glycerine, 8, 186, 516.
- " " " in analysis of lubricants, 329.
- " " " in analysis of Turkey red oils, 335.
- " " " in analysis of Yorkshire grease, 273.
- Acid, acetic, 20, 288.
- " " " as solvent (Valenta's test), 55-57, 347, 349.
- " " " formed from oleic acid 24, 28, 30, 387.
- " " acetyl oxyoleic, 189.
- " " " oxystearic, 186.
- " " acrylic, 25, 27.
- " " aldepalmitic, 24, 25.
- " " angelic, 25.
- " " anhydrodioxystearic, 42, 46.
- " " " possibly formed in blown oils, 319.
- " " arachic (arachidic, butic), 21.
- " " " separation from other fatty acids, 112.
- " " azelaic, 34, 35, 36.
- " " benic (behenic, benistearic), 21.
- " " benolic (behenolic), 31, 32, 45.
- " " benomargaric, 21, 22.
- " " benoxylic, 45.
- " " benzoic, 19, 32.
- " " benzoleic, 32.
- " " benzoyl oxymyristic, 37.
- " " brassic (brassaidic), 28, 29, 44, 129.
- " " bromohypogæic, 42.
- " " bromoleic, 28, 41.
- " " bromomyristic, 38.
- " " bromostearic, 30.
- " " butic—*see* Acid (arachic).
- " " butyric, 20, 288.
- " " camphic, 32.
- " " campholenic, 32.
- " " caproic—*see* Acid (hexoic).
- " " capric—*see* Acid (decoic).
- " " caprylic—*see* Acid (octoic).
- " " carbolic—*see* Phenol.

- Acid, carnaubic, 21.
 ,, cerotic, 21, 190, 358.
 ,, ,, formation, test of adulteration of beeswax, 359.
 ,, cetic, 21, 22.
 ,, chloriodostearic, 177.
 ,, chlorocrotonic, 31, 32.
 ,, chloropropiolic, 32.
 ,, cimicic, 25.
 ,, cinnamic, 19.
 ,, cocinic, 20, 22.
 ,, crotonic, 25, 288.
 ,, crotonoleic, 288.
 ,, damaluric, 24, 25.
 ,, daturic, 21.
 ,, decenoic, 25.
 ,, decoic (capric), 20, 190.
 ,, diacetyloxystearic, 190.
 ,, diallyl acetic, 32.
 ,, dibromopropionic, 27.
 ,, dibromostearic, 31, 41, 176.
 ,, dibromoxystearic, 176.
 ,, dichloracrylic, 32.
 ,, diiodostearic, 26.
 ,, dioxybenic, 28, 29, 44, 129.
 ,, dioxybenolic, 45.
 ,, dioxyhendecic, 44.
 ,, dioxypalmitic, 42, 44, 336.
 ,, dioxystearic, 28, 30, 41-45, 128, 190.
 ,, diricinoleic, 146.
 ,, diricinoleosulphuric, 146, 333.
 ,, dodecenoic, 25.
 ,, dodecoic—*see* Acid (lauric).
 ,, doeglic, 25.
 ,, ,, existence doubted, 24.
 ,, eleomargaric, 32.
 ,, elceostearic, 32.
 ,, elaidic, 28, 29, 43, 44.
 ,, enneadecic, 21.
 ,, ennoic, 25.
 ,, ennoic, 20, 36.
 ,, erucic, 25, 28, 29, 32, 44, 129, 180.
 ,, ,, characteristic of rape class, 284.
 ,, ,, oxidation products of, 28, 29, 44, 129.
 ,, formic, 20, 288.
 ,, geoceric, 21, 22.
 ,, geranic, 15.
 ,, glycerosulphuric, 144.
 ,, hendecenoic, 20, 25, 32, 40, 44.
 ,, hendecinoic (hendecolic, undecolic), 31, 32.
 ,, hendecic, 20.
 ,, hendecolic, 31, 32.
 ,, heptadecenoic, 25.
 ,, heptic (œnanthic), 20, 40, 41, 146
- Acid, hexabromostearic, 176.
 ,, hexacetyllinusic, 37.
 ,, hexoic (caproic), 20, 288.
 ,, hexoxacetylstearic, 37.
 ,, hexoxystearic, 19, 37, 43, 44, 128, 135.
 ,, hyænic, 21, 22.
 ,, hydrobenzoic, 32.
 ,, hydrochloric—*see* Hydrochloric acid.
 ,, hypogæic, 25, 44, 180.
 ,, ,, doubts as to existence of, 24, 111.
 ,, iodopropionic, 27.
 ,, iodostearic, 30, 38.
 ,, isobutyric, 20.
 ,, isodioxybenic, 29.
 ,, isodioxystearic—*see* Isomerides (dioxystearic acid).
 ,, isohexoic, 20.
 ,, isohexoxystearic—*see* Acid (isolinusic).
 ,, isoleic, 25, 29, 38, 43, 44.
 ,, ,, contained in distilled cotton seed stearine, 305.
 ,, ,, in candle stearine, 262, 375, 380.
 ,, ,, formed from zinc chloride and oleic acid, 143, 262, 380.
 ,, ,, formed during distillation, 262, 380.
 ,, isolinolenic, 37, 43, 128, 135.
 ,, isolinusic, 37, 43, 128, 135.
 ,, isoricinoleic, 41.
 ,, isotrioxystearic, 40, 43, 44.
 ,, isovaleric, 20.
 ,, isoxystearic—*see* Isomerides (oxystearic acid).
 ,, lauric, 20, 71-74, 190, 288.
 ,, lignoceric, 21.
 ,, linoleic, 33, 134.
 ,, linolenic, 35, 36, 43, 44, 128, 135, 176, 180.
 ,, linolic, 30-33, 90, 176, 180.
 ,, ,, not contained in animal oils, 291.
 ,, ,, oxidation products of, 19, 34, 35, 43-45, 128-137.
 ,, linusic, 19, 37, 43, 44, 128, 135.
 ,, margaric, 21, 22, 309.
 ,, ,, artificial, 21, 309.
 ,, medullic, 21, 22.
 ,, melissic, 13, 21, 358.
 ,, methyl crotonic—*see* Acid (tiglic).
 ,, moringic, 24, 25.
 ,, myristic, 20, 31, 32, 71-73, 113, 288.

- Acid, myristolic, 31, 32.**
 „ nitrous, test with—*see* Elaidin reaction.
 „ nitric, test with—*see* Nitric acid.
 „ octenoic, 25.
 „ octoic, 20.
 „ œnanthic—*see* Acid (heptoic).
 „ oleic, 25, 38, 68, 75, 90-92, 113.
 „ „ action of acetic anhydride on, 190.
 „ „ „ of bromine and iodine on, 27, 176, 180.
 „ „ „ of fused potash on, 24, 28, 30, 387.
 „ „ „ of nitrous acid on (elaidin reaction), 28.
 „ „ „ of sulphuric acid on, 27, 145, 149.
 „ „ „ of sulphur chloride on, 155, 156.
 „ „ „ of zinc chloride on, 39, 142.
 „ „ amount in candle stearine, 375-377.
 „ „ conversion into stearic acid, 26, 386, 387.
 „ „ determination of (Muter's process), 376.
 „ „ oxidation products of, 10, 28, 43-45, 128.
 „ „ separation from other acids, 112, 376.
 „ „ soap—*see* Soapmaking.
 „ „ yield from ox fat, 311.
 See also Red oils.
 „ oleo-oxystearic, 330, 331.
 „ oleo-stearic, 331.
 „ orthopropionic, 12.
 „ oxybenzoic—*see* Acid (salicylic).
 „ oxyhypogœic, 41, 43.
 „ oxylinoleic, 125, 134.
 „ oxymyristic, 37, 38.
 „ oxyoleic, 41, 42, 43, 332.
 „ „ contained in dégras, 336.
 „ „ formed in blowing oils, 319.
 „ oxypalmitic, 38.
 „ oxystearic, 25, 27, 38, 39, 43, 143-145, 330, 384.
 „ oxystearosulphuric, 27, 29, 38, 144, 330.
 „ palmitic, 21, 44, 72, 74, 91.
 „ „ action of acetic anhydride on, 190.
 „ „ artificial, manufacture of, 387.
 „ „ formation from cetyl alcohol, 13.
- Acid, palmitic, formation from oleic, isoleic, and elaidic acids, 30—*see also***
Acid, oleic, action of potash on.
 „ „ mixed with stearic—*see* Candle stearine.
 „ „ occurrence in arachis oil denied, 111.
 „ „ present in spermaceti of low grade, 361.
 „ „ separation from other acids, 112, 113, 376.
 „ „ used for night lights, 407.
 „ palmitolic, 31, 32, 45.
 „ palmitoxylic, 45.
 „ paraffinic, 21.
 „ parasorbic, 32.
 „ pelargonic—*see* Acid (ennoic).
 „ pentadecoic, 20, 21.
 „ pentaricinoleic, 147.
 „ pentoic, 20.
 „ pentolic, 32.
 „ petroleumatic, 25.
 „ phoronic, 25.
 „ phosphoric, colour test, 151.
 „ physetoleic, 4, 25.
 „ „ characteristic of train oils, 292.
 „ propiolic, 32.
 „ propionic, 20.
 „ pyroterebic, 25.
 „ rapic, 41, 43, 284.
 „ ricilinolic, 32, 36.
 „ ricinelaïdic, 40, 43, 44.
 „ ricinic, 41.
 „ ricinoleic, 39, 40, 90, 176, 180.
 „ „ action of fused potash on, 40.
 „ „ oxidation products of, 19, 40, 43, 44, 129.
 „ „ polymerised, 146, 147, 333.
 „ ricinoleosulphuric, 145, 332, 333.
 „ salicylic, 5, 19.
 „ sativic, 19, 34, 35, 43-45, 135.
 „ „ as characteristic oxidation product, 128, 344.
 „ „ formed from olive oil, 344.
 „ „ not formed from animal oils, 291.
 „ sebacic, 40.
 „ sorbic, 32.
 „ stearic, 21, 72, 73, 88-92, 155, 156, 190, 309.
 „ „ adulterant of beeswax and spermaceti, 359, 361.
 „ „ formed from linolic acid, 34.
 „ „ „ from oleic acid, 26, 386, 387.

- Acid, stearic, formed from ricinoleic acid, 40.**
 „ „ formed from *sativic acid*, 35.
 „ „ separation from other acids, 112, 113, 376.
 „ „ yield from ox fat, 311.
See also Candle stearine.
 „ stearidic, 25, 30.
 „ stearolic, 31-33, 35, 45.
 „ stearylic, 33, 36, 45.
 „ stillistearic, 21, 22.
 „ suberic, 36.
 „ sulphuric—*see* Sulphuric acid.
 „ sulphurous—*see* Sulphurous acid.
 „ tariric, 32, 36.
 „ terebic, 25.
 „ tetrabromostearic, 31, 176.
 „ tetracetyl *sativic*, 35.
 „ tetradecenoic, 25.
 „ tetraricinoleic, 147.
 „ tetrolic, 31, 32.
 „ tetroxystearic—*see* Acid (*sativic*).
 „ tetroxycetyl stearic, 35.
 „ theobromic, 21, 22.
 „ tiglic (methylcrotonic), 25, 288.
 „ toluic, 19.
 „ tridecenoic, 25.
 „ tridecoic, 20, 22.
 „ trioxystearic, 19, 40, 43, 44, 129.
 „ trioxycetyl stearic, 41.
 „ triricinoleic, 147.
 „ tritylic, 20.
 „ umbellulic, 20.
 „ undecolic—*see* Acid (*hendecolic*).
 „ undecylic—*see* Acid (*hendecolic*).
 „ undecylenic—*see* Acid (*hendecenoic*).
 „ valeric, 20, 275, 288.
Acid number, free—*see* Acids (free fatty).
 „ „ total—*see* Total acid number.
 „ process (oil refining), 259.
 „ salts, 23.
Acidity of soaps, 24, 493.
Acids, dibasic, 18.
 „ distilled (manufacturing plant), 382-384.
 „ „ melting points, 384.
 „ fatty; formed by hydrolysis and saponification, 7, 10, 12, 114.
 „ „ „ during systematic examination of oils, &c., 124.
- Acids, fatty; formed from alcohols by action of fused potash, 13.**
 „ „ from glycerides, yield of, 163.
 „ „ from soap, 172.
 „ „ from tallow, palm oil, &c.: valuation by melting point, 75, 76.
 „ „ from various oils, &c.; melting points, 69-76.
 „ „ insoluble in water—*see* Hehner number; Insoluble acid number.
 „ „ insoluble in petroleum ether, from boiled oils, 135.
 „ „ iodine number of—*see* Iodine number.
 „ „ mean equivalent, 116, 164-173, 196.
 „ „ mean equivalent is less than saponification equivalent of glycerides by 12.67, 165, 197.
 „ „ melting points of—*see* Melting points.
 „ „ mixtures of; calculation of composition, 172.
 „ „ neutralisation numbers of—*see* Neutralisation number.
 „ „ oxidation during drying, 113.
 „ „ oxidation of, from drying oils, 136.
 „ „ polymerised, from castor oil, 146.
 „ „ separation of, as lead salts, &c., 112, 128, 136, 356, 376.
 „ „ solid from tallow and palm oil, 74-76—*see* Candle stearine.
 „ „ soluble in alcohol, 23.
 „ „ soluble in water, 23, 163, 167-170, 195.
 „ „ soluble in soap analysis, 497.
 „ „ soluble acid number—*see* Soluble acid number.
 „ „ volatile, 22, 113—*see also* Boiling points.
 „ „ „ acid number—*see* Volatile acid number.
 „ „ „ contained in Yorkshire grease, 275.
 „ „ „ with superheated steam—*see* Distillation.

- Acids, fatty, volatile, with wet steam,** 22, 112—*see also* Reichert number; Volatile acid number.
- “ “ **unsaturated, in pressed candle stearine,** 375.
- “ **free fatty, amount present in oilcakes,** 115, 214.
- “ “ **as candle material**—*see* Candles, stearine.
- “ “ **determination of free acid number,** 24, 115-119, 194, 341.
- “ “ **determination of, by Burstyn's method,** 118.
- “ “ **detrimental effects of,** 115, 260, 313, 322, 356.
- “ “ **examination of, for detecting adulteration,** 356.
- “ “ **formed by hydrolysis**—*see* Hydrolysis.
- “ “ **from Turkey red oils,** 334, 335.
- “ “ **iodine number,** 180, 184, 197, 356.
- “ “ **iodine number exceeds that of glycerides by about 4.5 per cent.,** 185, 197.
- “ “ **occurrence in natural oils, &c.,** 114-119, 292, 355.
- “ “ **production of, in grease recovery,** 271, 272.
- “ “ **proportion usually present,** 115.
- “ **mineral, detection of,** 123, 323.
- “ “ **inadmissible in purifying lubricants,** 325.
- “ “ **injurious effects of,** 115, 260, 322, 325.
- “ **monobasic,** 18.
- “ **polyhydroxylated stearic,** 43-46, 128-137.
- “ **series of, acetic (stearic),** 18, 19.
- “ “ **acrylic (oleic),** 18, 24.
- “ “ **benzoic,** 19.
- “ “ **bromoleic,** 28.
- “ “ **cinnamic,** 19.
- “ “ **dichloroacetic,** 31.
- Acids, series of, dibromoacetic,** 26, 31.
- “ “ **diiodoacetic,** 26.
- “ “ **dioxy stearic**—*see* Glyceric series.
- “ “ **erythroglucic (trioxy stearic),** 19, 43.
- “ “ **glyceric (dioxy stearic),** 19, 27, 43.
- “ “ **glycollic**—*see* Oxyacetic series.
- “ “ **hexoxystearic,** 19, 43.
- “ “ **linolenic,** 18, 36.
- “ “ **linolic**—*see* Propiolic series.
- “ “ **oleic**—*see* Acrylic series.
- “ “ **oxyacetic (oxy stearic, glycollic),** 19, 27, 37.
- “ “ **oxyacrylic (ricinoleic),** 19, 39.
- “ “ **oxybenzoic,** 19.
- “ “ **oxyoleic**—*see* Oxyacrylic series.
- “ “ **oxystearic**—*see* Oxyacetic series.
- “ “ **propiolic (linolic),** 18, 28, 30.
- “ “ **ricinoleic**—*see* Oxyacrylic series.
- “ “ **salicylic,** 19.
- “ “ **stearic**—*see* Acetic series.
- “ “ **stearolic,** 30, 31, 45.
- “ “ **stearoxylic,** 33, 45.
- “ “ **tetroxystearic,** 19, 43.
- “ “ **trioxystearic**—*see* Erythroglucic series.
- Acrolein (acrylic aldehyde),** 15, 25.
- “ **in glycerine,** 515.
- “ **produced by action of heat on oils,** 125.
- “ “ **dehydration of glycerol,** 8, 513.
- “ “ **oxidation of linseed oil (linoleum),** 318.
- Actual density, incorrect use of term,** 89.
- Adipose tissues, Mège Mouriés process,** 308.
- “ **rendering of,** 245-251.
- “ **use of, as food,** 303.
- Adulteration, general methods of detecting,** 340-342—*see also* each oil, &c., separately.
- “ **with solid suspended matters, determination,** 123.
- Æsculin,** 50.

- Ætherzahl—*see* Ester number.
- Air, bleaching oils by means of hot, 264.
- „ used in preparing blown oils—*see* Oils, blown.
- „ „ „ boiled oils—*see* Oils, drying, boiling of.
- „ wax bleaching by exposure to, and light, 268.
- Air bath, Pensky's, flashing point, 127.
- „ Pohl's, melting point, 63.
- „ specific gravity, 80.
- Air blast, Dunn's (soapboiling), 433.
- Albuminous matters, determination, 119-123.
- „ „ removal from crude glycerine, 514, 515.
- „ „ removal from oils, &c. — *see* Oils (clarification).
- Alcohol, allylic, 15, 44.
- „ amylic, 14.
- „ benzylic, 16.
- „ butylic, 14.
- „ cerylic, 14.
- „ „ present in Yorkshire grease, 272.
- „ cetylic, 4, 6, 7, 14.
- „ „ action of acetic anhydride on, 15, 191.
- „ „ action of fused potash on, 13.
- „ „ contained in cetacean oils, 114, 116, 121.
- „ „ contained in dégras, 336.
- „ „ contained in spermaceti — *see* Spermaceti.
- „ „ contained in Yorkshire grease, 272.
- „ „ palmitic acid from, 13.
- „ cinnamic, 16.
- „ decylic (decatylic), 14, 40.
- „ dodecylic (dodecatylic), 14, 114.
- „ ethylic, 4, 14.
- „ hendecylic, 14.
- „ heptadecylic, 14.
- „ heptylic, 14.
- „ hexadecylic, 14.
- „ hexylic, 14.
- „ isobutylic, 14, 20.
- „ isocerylic, 14.
- „ isomyricylic, 14.
- „ isopropylic, 14.
- „ methylic, 5, 14.
- „ myricylic, 4, 14, 21, 358.
- „ „ action of fused potash on, 13.
- „ nonylic, 14.
- Alcohol, octodecylic, 14.
- „ octylic, 5, 14.
- „ pentadecylic, 14.
- „ propylic, 14, 20.
- „ sycocerylic, 16.
- „ tetradecylic, 14.
- „ tridecylic, 14.
- „ xylylic, 16.
- Alcohol, solubility in—*see* Solubility.
- Alcoholiform products of saponification, 4-18, 121.
- Alcohols, acetyl numbers of, 17.
- „ dihydric—*see* Glycols.
- „ fermentation — *see* Oils (fusel).
- „ free in oils, due to hydrolysis, 7, 114, 116, 171.
- „ hexhydric, 5.
- „ higher, contained in Yorkshire grease, 272.
- „ monohydric, 4, 13.
- „ pentahydric, 5.
- „ series of, acrylic (allylic), 13, 15, 44, 114.
- „ „ benzylic, 15, 16.
- „ „ cholesteric, 16.
- „ „ cinnamic, 13, 16.
- „ „ ethylic, 13, 14, 114, 116.
- „ „ geranic, 15.
- „ „ phenolic, 13, 15.
- „ tetrahydric—*see* Erythrol.
- „ trihydric—*see* Glycerols.
- Aldehydes, 3, 6, 15.
- „ hydrogenation of, 14.
- „ oxidation of, 20, 25.
- Alkali, calculated quantity requisite for saponification—*see* Calculations.
- „ free, in soaps, injurious effects of—*see* Soaps, alkaline.
- Alkalies, action on brominated and chlorinated acids, 28-32, 38.
- „ effect of fusion with—*see* Hydrogen.
- „ effect of fusion with, on oleic acid and isomerides — *see* Acid (oleic, palmitic).
- „ „ on ricinoleic acid, 40.
- „ manufacture of, 410.
- „ mild and caustic, 409—*see* Potash (caustic), Soda (caustic).
- „ quantities mutually equivalent to one another, 425.
- „ use of, in refining oils, &c., 260.
- „ use of, in soapmaking, 409.
- „ vegetable and mineral, 410—*see* Potash, Soda.

- Alkalimetric assay, 420.
- Alkaline carbonates as saponifying agents, 409, 410.
- „ „ causticising of — *see* Causticising.
- „ „ direct use in soap-making, 409, 433, 453, 460, 463.
- „ earths, use in refining, 256.
- „ refining processes — *see* Refining.
- „ soap, injurious effects — *see* Soap, alkaline.
- „ solutions, strength of, 418, 419.
- Alkalinity, degrees of — *see* Degrees.
- „ negative, 498, 499.
- „ of leys, 414-419.
- „ „ corrections for impurities, 419.
- „ „ effect of temperature on density, 416.
- „ of soda, British trade custom, 420.
- Allbright & Clark, spontaneous inflammation, 132.
- Allen, A. H., beeswax, 358, 359.
- „ bromine reaction, 177.
- „ distilled cotton seed stearine, 305.
- „ glycerine valuation, 519.
- „ linolic acid, 34.
- „ Maumené's test, 149.
- „ melting points, 71.
- „ nitric acid test, 140.
- „ Reichert's test, 174.
- „ relative density, 89, 93.
- „ saponification equivalents, 160.
- „ soap analysis, 494, 507.
- „ sugar test for sesamé, 346.
- „ sulphur in oils, 123.
- „ sulphuric acid colour reactions, 151.
- „ test for arachis oil, 344.
- „ Valenta's test, 56.
- „ viscosimetry, 99, 101, 104.
- „ waggon grease, 327.
- Allen and Nickels, glycerine extraction, 515
- Allen and Thomson, free alcohols in sperm oil, &c., 171.
- „ unsaponifiable matters in various oils, &c., 257.
- Alligator fat, 299.
- Allihu's condenser, 239.
- Allyl cyanide, 25.
- „ ethers, 15, 25.
- Almonds, sweet and bitter — *see* Oil (almonds).
- Alpaca fat, 299.
- Alum in lard, 307.
- „ use in cleansing rancid tallow, 256.
- Aluminium oleate used in thickening oils, 121-124, 324, 329.
- „ soaps, 121-124, 324, 328, 329.
- Aluminoferric cake, aluminium sulphate, use in recovering grease, 270.
- Amagat and Jean, oleorefractometer, 51.
- Ambreol (amberggris), 3, 17.
- Ambühl, specific gravity vapour bath, 80.
- American mineral oils, viscosity, 105.
- Ammonia process for alkali manufacture, 410.
- „ saponification process, 379, 410, 515.
- „ salt, dealkalising process (Alder Wright's) — *see* Wright, Alder.
- Angelica, 25.
- Anglo-American system of oil pressing, 210, 215-218.
- Anhydrides, fatty, in analysis, 371.
- „ of dioxytearic acids, 42, 46.
- „ of nonhydroxylated acids, 189.
- „ of oxytearic acids, 30, 39.
- Animal charcoal, use of, in decolorising oils, &c., 263, 269.
- „ „ use of, in deodorising cokernut oil, 310.
- „ „ „ in purifying glycerine, 514.
- „ „ „ in purifying lanolin, 339.
- „ fats, acids from, 21, 25.
- „ „ rendering of, 245-251.
- Anise camphor (anethol), 192, 194.
- Anschütz, action of acetic anhydride on benzoic acid, &c., 189.
- Anthracene, extraction from anthracene oils, 230.
- „ oils (coarse lubricants), 328.
- Antifriction ingredients, 324-328.
- Aqua regia, colour test, 151.
- Arachin (arachic glyceride), chief constituent of Rambutan tallow, 296.
- Arachis nuts, decortication of, 224.
- Aræometer, 77.
- „ (Burstyn's method), 118.
- „ Lefebre's, 79.
- „ thermal, 82, 347.
- Archimedean screw (mixing soap), 440.
- Archbutt, elaidin test, 138.
- „ free fatty acids in burning oils, 313.

- Archbutt, Maumené's test, 149.
 Argand lamp, 313.
 Arnaud, tariric acid, 36.
 Ashes as detergents, 409.
 Artificial butter—*see* Margarine.
 " lard—*see* Lard.
 Autoclave for soapmaking—*see* Soap-
 making (hydrated soaps).
 " rock, 374.
 " stearine process, 373—*see*
 Candle stearine.
 Axle grease—*see* Lubricants.
- B**
- BACH, absorption of oxygen, 134, 329.
 " melting points, 71.
 Bagging for presscakes, 217.
 " of semisolid oils to separate
 " "stearines," spermaceti,
 &c., 229, 305, 360.
 Ballantyne, effect of light on oils,
 130-132, 149—*see also* Thomson and
 Ballantyne.
 Balsam of Peru, 16.
 " Tolu, 19.
 Barilla, 410, 473.
 Barium polysulphide (colour test), 151.
 " sulphate, adulterant of wax, 359.
 Barring (soap), 437, 438, 444.
 Baths—*see* Air bath, Hot baths,
 Chilling baths, Vapour baths,
 Water baths, &c.
 Bauer and Hazura, drying oils, 136, 290.
 Baynes, Maumené's test, 149.
 Beans, fatty matter contained in
 various kinds of, 241-244.
 Bears' grease, 299.
 Beaumé, rational scale, 86.
 Becchi's test for cotton seed oil, 131,
 306, 346.
 Beechwood tar, 21.
 Beef fat, beef tallow—*see* Tallow.
 Beef stearine—*see* Stearine (beef).
 Beeswax—*see* Wax (bees).
 Beet fusel oils, 14.
 Bell, J. Carter, lubricating oils, 325.
 Bender, viscosity, 106.
 Benedikt, beeswax, 358.
 " density of glycerol solu-
 tion, 517.
 " hydrometer scales, 85.
 " iodine numbers, 183.
 " iodine number of linseed
 oil, 351.
 " phosphorus in oils, 124.
 " total acid numbers, 160.
 " use of acetylation test, 129,
 516.
 Benedikt, zinc chloride and oleic acid
 39, 142.
 Benedikt and Grüssner, methyl num-
 ber, 192.
 Benedikt and Hazura, nonformation
 of sativic acid from animal oils, 291.
 Benedikt and Ulzer, acetylation test—
 see Acetylation test.
 " " oxyoleic acid, 42.
 " " oxystearosulphuric
 acid, 145.
 Benedikt and Zsigmondy, glycerine
 valuation, 519, 521.
 Bennett and Gibbs (soapmaking under
 pressure), 463.
 Benno Jappé & Co., glycerine extrac-
 tion, 515.
 Bensemman, melting points, 71.
 " tubes, 62.
 Benzene, 3.
 " as solvent, 55, 231, 236, 252,
 254, 337, 339, 359.
 Benzoic aldehyde, 3.
 " ethers, 17.
 Benzoline—*see* Petroleum ether.
 Beyer, plotting machine, 448.
 Bicarbonate formed during saponifi-
 cation, 410.
 Bichromate process, glycerol estima-
 tion—*see* Glycerine,
 manufacture of
 (valuation).
 " " (oil bleaching), 264-266.
 " " (wax bleaching), 266,
 269.
 Biliary constituents in liver oils,
 292, 354.
 Bishop, polarised light, 50.
 Bladder lard, 306.
 Bleaching oils. &c., 50, 263-269, 358,
 364.
 " powder, use of in decoloris-
 ing oils, 264, 266, 267.
 Blown oils—*see* Oils (blown).
 Blowpipe, 428, 433.
 Blubber, extraction of oil from, 247.
 Bock's process, 384.
 Boiling down blubber, &c., 247.
 " oils, changes occurring during,
 125, 129.
 " points, acetic acid series, 20.
 " " acrylic, 25, 28, 29.
 " " alcohols, 14.
 " " pure triglycerides, 11.
 " processes, 313-318.
 Bone fat (bone grease, bone oil), 67,
 88-91, 160, 181-184, 298, 299.
 " adulteration of tallow fat
 with, 355.

- Bone fat, extraction of, from bones, 251-254.
 „ removal of calcium phosphate, &c., contained in, 256.
- Bone tar (bone oil, Dippel's oil), 2, 5.
- Borneol, 15.
- Borith, 449.
- Bosch—*see* Margarine.
- Bottlenose whale—*see* Oil (Doegling).
- Bran from cotton seeds, 304.
- Brandy fusel oils, 14.
- Brassica (rape, colza), various species of, 348.
- Braun and Liebreich, lanolin, 338.
- Brez, de, moulded candles invented by, 363, 395.
- Brine—*see* Salting out.
- Brink, caoutchouc in lubricating oils, 323.
- Brin's Oxygen Co., oil boiling process, 321.
- Bromine absorption, 26, 176-179.
 „ reaction, forming propiolic acids, 31, 32, 45.
- Bromo substitution derivatives—*see* Substitution.
- Bruijn, de, and von Leent, oleo-fractometer, 51-53.
- Buccia (olive marc), 343.
- Buisine, beeswax, 269, 358.
- Burstyn's method, 118.
- Butter, animal, 174, 298.
 „ „ (ewes', goats', porpoises'), Reichert number of, 174.
 „ cow's, adulteration of, 310.
 „ „ fat of, 3, 9, 299.
 „ „ „ acids obtainable from, 20, 25, 70.
 „ „ „ Hehner number, 166, 310.
 „ „ „ iodine number, 181-184, 310.
 „ „ „ melting point, 67-70.
 „ „ „ refractive power, 51-53.
 „ „ „ Reichert number, 174, 310.
 „ „ „ saponification equivalent, 160, 310.
 „ „ „ solubility, 54-56.
 „ „ „ specific gravity, 88-92.
 „ „ „ quality of, 303.
 „ „ „ salt contained in, 123.
 „ „ „ sweetening rancid, by washing with water, 261.
- Butter, cow's, water contained in, 122.
 „ general nature of, 1.
 „ mineral (antimony, tin), 1.
 „ vegetable (vegetable fat, vegetable tallow), 2, 6, 47.
 „ „ class, 282, 295.
- Butters, vegetable, expression oleines from—*see* Oleines.
 „ „ lesser known, 295-298.
- Butters, vegetable—
 Andiroba fat—*see* Oil (carapa).
 Bassia fat (Illipè butter, Mahwa butter), 21, 56, 67, 87, 241, 243, 295, 363.
 Bayberry fat—*see* *infra* Laurel butter.
 Borneo tallow (Malayan tallow, Fever nut butter), 242, 296.
 Butter nut fat, 297.
 Cacao butter, 21, 241, 295.
 „ chemical properties, 160, 174, 181-184.
 „ physical properties, 55, 56, 67-70, 87, 88, 91.
 „ theobromic acid in, 21, 22.
- Carapa fat—*see* Oil (carapa).
- Chinese (Stillingia) tallow, 21, 70, 295, 363.
 „ „ extraction by hot water process, 201.
 „ „ yield of, 242.
- Chequito butter, 297.
- Cocculus indicus fat, 297.
- Coker butter—*see* Oil (cokernut).
- Copra butter— „ „
 Coumou butter—*see* Oil (coumu).
- Dika fat, 2, 20, 242, 295.
- Fever nut butter—*see* *supra* Borneo tallow.
- Fulwah butter (Indian butter), 242, 295.
- Galam butter—*see* *infra* (Shea butter).
- Goa butter (Kokum fat, Mangosteen oil), 68, 242, 296.
- Illipè butter—*see* *supra* Bassia fat.
- Indian (Fulwa) butter—*see* *supra* Fulwah butter.
- Karanja butter, Korinje butter (Ponga butter, Ponga oil, Poondi oil), 242, 296.
- Kokum fat—*see* *supra* Goa butter.
- Laurel butter (Laurel oil, Bayberry fat), 20, 56, 68, 181-184, 243, 296.
- Macaaja butter, 243, 297.
- Mafura tallow, 243, 296.

- Butters, vegetable—
 Mahwa butter—*see supra* Bassia fat.
 Malayan tallow—*see supra* Borneo tallow.
 Malabar (Piney) tallow, 70, 160, 244, 295, 363.
 Myristica butters, 295.
 Nutmeg butter—*see* Oil (nutmeg).
 Ochoco fat, 297.
 Ocuba fat, 295.
 Otoba fat (Otoba wax), 243, 295.
 Palm butter—*see* Oil (palm).
 Palm kernel (Palm nut) butter—*see* Oil (palm kernel).
 Para butter (Assai oil), 297.
 Peka butter (Piquia fat)—*see* Oil (piquia).
 Persea fat—*see* Oil (alligator pear).
 Phulwara fat—*see* Fulwah butter.
 Pichurim bean fat, 20.
 Piney tallow—*see supra* Malabar tallow.
 Ponga butter—*see supra* Karanja butter.
 Poona fat—*see* Oil (calabar bean).
 Rambutan tallow, 296.
 Sawarri (Souari) nut butter, 297.
 Shea (Galam) butter, 2, 21, 70, 71, 160, 242, 295.
 Sierra Leone butter, 244, 296.
 Soapberry butter (Soap tree fat), 244, 297.
 Soudan butter, 297.
 Stillingia tallow—*see supra* Chinese tallow.
 Tacamahac fat—*see* Oil (calabar bean).
 Tangkallak fat, 244, 297.
 Ucuba fat (Ucuba wax), 295.
 Virola fat, 68, 295.
 Veppam fat—*see* Oil (zedrach).
 Butterine (butter substitutes; artificial butter)—*see* Margarine.
 Butyrim (butyric triglyceride), 9, 11.
 „ not contained in butter, 9.
- C**
- CABBAGE palm oil—*see* Oil (areca nut).
 Cacao butter—*see* Butters, vegetable (Cacao butter).
 Cadmium salts, use in refining oils, 263.
 Cailletet, bromine reaction, 177.
 „ soap analysis, 507, 508.
 Cake, cold press—*see* Cold press cake.
 „ filter—*see* Filter cake.
 „ hot press—*see* Hot press cake.
- Cake, separation—*see* Separation cake.
 Cakes, linseed, &c.—*see* Oilcakes.
 „ moulded, 221-223.
 Calcium chloride, use of, in grease recovery, 271.
 „ sulphate, formed in decomposition of rock, 366.
 Calculations, composition of mixtures, 172.
 „ „ of rock, 372.
 „ „ of separation cake, &c., 378.
 „ respecting alkaline leys and composition of soaps, 421-426, 454-456, 464-466.
 Cambacères, braided wicks, 394.
 Camphor, acids from, 25, 32.
 „ analogues, 3, 6.
 „ Borneo, 15.
 „ sodium, oxidation of, 25.
 Camp, moulding wheel, 398.
 Candle polishing, 405.
 Candle stearine, 110, 230, 393.
 „ „ breaking grain of, 368, 397, 401.
 „ „ crystallising—*see* Separation cake.
 „ „ manufacture, 364-388.
 „ „ „ autoclave lime process, 364, 373-376.
 „ „ „ conversion of red oils into stearine, 142, 386-388.
 „ „ „ cold pressing—*see* Cold press.
 „ „ „ hot pressing—*see* Hot press.
 „ „ „ hydrolysis by water under increased pressure, 365, 385, 386.
 „ „ „ open pan lime process, 364-370.
 „ „ „ rock (lime soaps) 366, 371-374.
 „ „ „ sulphuric acid processes, 365, 380-385.
 „ „ „ unsaponified fat, &c.—*see* Unsaponified.
 „ „ „ yield, 368, 370-374.
 „ „ „ mixed fatty acids—*see* Acids, fatty, mixtures of; Melting points.

- Candle wicks—*see* Wicks.
- Candlemaking materials, 302, 363.
- “ processes, basting wax tapers, &c., 389.
- “ „ dipping by hand, 390, 391.
- “ „ dipping by machine, 391-394.
- “ „ drawing wax tapers, spills, &c., 389, 407.
- “ „ manipulation required in moulding with various materials, 401.
- “ „ moulding by hand, 395-398.
- “ „ moulding by machine, 398-406.
- “ „ pouring, 388, 389.
- “ „ threading wicks, 397, 399, 400, 406.
- “ „ trimming, 389.
- “ „ turnover machine, 405.
- Candles, ceresin, ozokerite, and paraffin, 363, 364, 401, 402.
- “ composite, 364, 402.
- “ early forms of, 312, 313, 362, 390, 391.
- “ hollow, 402, 405.
- “ medicated, 407.
- “ self-fitting butt end, 402.
- “ spermaceti (sperm), 360, 363, 402.
- “ spiral, 402.
- “ standard (photometric), 402.
- “ stearine, 395, 401.
- “ tallow, 363, 402.
- “ tinted, 390, 401, 405.
- “ wax, 301, 362-364, 389.
- Caoutchouc, use in lubricating oils, 323.
- Capillary tubes (melting points), 60-63.
- “ (friction coefficient), 107, 109.
- Capric aldehyde, 14.
- Carapin, 296.
- Carbolic acid—*see* Phenol.
- “ soaps, 6, 477, 505, 506.
- “ soaps, valuation of phenoloids in, 506.
- Carbon dioxide, atmosphere of, for cod liver oil extraction, 248.
- Carbon disulphide as solvent, 55, 123, 124, 231-236, 252, 254, 337, 339, 343.
- “ diluent for sulphur chloride, 155.
- Carbon disulphide lamp for disinfecting, 407.
- “ „ “ sulphocarbon oils ” extracted by, 344, 408.
- Carbon tetrachloride as solvent, 55, 236.
- Carbonates, alkaline, direct saponification by—*see* Alkaline carbonates, Sodium carbonate.
- Carnauba wax—*see* Wax (Carnauba).
- Carriage grease—*see* Lubricants.
- Carriers of oxygen (driers), 129, 264.
- Cart grease—*see* Lubricants.
- Casein in butter, 123.
- Cast iron less corroded than wrought by fatty acids, 277.
- Castor beans, decortication of, 224.
- Castorol (castoreum), 17.
- Cattle food, 303—*see also* Oilcake.
- Caustic soda—*see* Soda, caustic.
- Causticising alkaline leys, 409-414.
- “ boiling process, 412.
- “ cold process, 411.
- “ under pressure, 413.
- Centigrade scale, 57-60.
- Ceresin (cerasin), 2, 88.
- “ „ detection of, in beeswax, 359.
- Cerolein, 358.
- Ceroxylin, 301.
- Cetaceans, oil from blubber of—*see* Oils (cetacean).
- Cetylcyanide, margaric acid from, 21.
- Cetylic ethers, 4, 7.
- Chandlery (candlemaking trade), 363.
- Charcoal, use of, in clarifying and decolorising oils, &c., 255, 263, 269—*see also* Animal charcoal.
- Charring of wicks—*see* Wicks.
- Chateau, colour reactions, 142, 151.
- Chattaway's tube, 120.
- Chemical changes during boiling, 317.
- “ „ during drying of oils—*see* Oils (drying of).
- Chevreul, researches on fats, 309.
- Chevreul and Gay Lussac, candle material, 365.
- Chevreul-Milly process, 365.
- Chequito, 297.
- Chilling baths, 66, 67.
- “ effect on viscosity, 106.
- Chimneys (lamp), 313.
- China clay as adulterant, 123, 355, 359.
- “ (antifriction), 328.
- Chinese wax—*see* Wax (Chinese).
- Chlorate, potassium, use of, in bleaching oils, &c., 264, 266.
- Chloride of soda for soap bleaching, 267.

- Chlorine, action on ethylene, 26.
 ,, bleaching by means of, 264-267, 364.
 ,, gas, test for fish oils in linseed oil, 352.
- Chloroform as solvent, 17, 55, 231, 359.
- Chlorophyll, 49, 50.
- Chloro substitution derivatives—*see* Substitution.
- Cholesterol, allied bodies, and their ethers, 3, 6, 16, 17, 259.
 ,, and its ethers in Yorkshire grease, 272-276.
 ,, determination of, in lubricants, 329.
 ,, ethers, 17.
 ,, extraction from oils, 119-121.
 ,, lanolin, 337-339.
 ,, occurs in dégras, 336.
 ,, ,, liver and cetacean oils, 17, 292.
 ,, ,, suint, 337.
- Choline derivatives—*see* Lecithin.
- Chromate, processes for bleaching oils, wax, &c.—*see* Bichromate.
 ,, reaction with glycerol—*see* Glycerol extraction (valuation by bichromate process).
- Chrome recovery, 265.
- Chromium compounds as driers, 314.
- Cierges (altar candles), 389.
- Cinchol, 22.
- Clarification—*see* Oils (clarification).
- Clarke, oils boiled with manganese driers, 314.
- Clark's soap test for hard water, 485, 508.
- Classification of oils, &c., according to chemical composition, 5.
 ,, ,, according to composition, sources, and texture, 281-302.
 ,, ,, according to relative density, 89-92.
 ,, ,, according to saponification equivalents, 158.
 ,, ,, according to uses, 302-339.
 ,, of soaps according to alkalinity, 512.
- Clay, China—*see* China clay.
 ,, use of, in refining oils, &c., 255.
- Cleansing engine waste, 237.
- Cloez, elæococca oil, 291.
- Close soap, 468, 473.
 ,, test (flashing point), 126.
- Cloth dressing, use of oils for, 302.
- Coagulate (grease recovery), 271, 272.
- Coagulation of mucilage and albuminous matters—*see* Oils, clarification of.
- Coaltar oils—*see* Oils (coaltar).
- Cobalt compounds as driers, 314.
- Cochineal as indicator, 420, 497.
- Cod livers, extraction of oil from, 247.
- Coefficient of expansion of glass, 77.
 ,, oils, 79, 92-94.
 ,, friction in capillary tubes, 107.
 ,, ,, Traube's apparatus, 109.
- Cogan's process (oil refining), 259.
- Cohesion figures, 48, 345.
- Coils, steam—*see* Steam (wet and dry).
- Cokernut, machine for splitting, 224.
 ,, oleine—*see* Oleine (cokernut).
 ,, spelling of word, 3.
 ,, stearine—*see* Stearine (cokernut).
- Cold drawn oils—*see* Oils (cold drawn).
 ,, press cake, 375.
 ,, ,, (candle stearine), 231, 355, 368.
 ,, process soaps—*see* Soap-making.
- Colloidal mucilage, 255.
 ,, state of soap, 458, 466, 481, 485.
 ,, ,, facilitated by presence of alcohol, sugar, glycerol, 458, 481.
 ,, ,, ,, by use of castor oil, 481.
 ,, ,, ,, by use of potash instead of soda, 459, 481.
- Colorimeter, 50.
- Colour of boiled oils, 315.
 ,, oils, 49, 263, 341.
- Colour reactions with nitric acid, 139.
 ,, ,, sulphuric acid, 151-153.
 ,, ,, zinc chloride, &c., 141, 151-154.
 ,, of seal, whale, liver, and fish oils, 294.
- Colouring matters contained in oils, 49, 263.
 ,, ,, for candles, 405.
- Colza (rape, coleseed), various species of, 348.

- Combustion, destruction of noxious smells by, 247, 250.
- Composite candles—*see* Candles.
- Composition of mixtures, calculation of, 172.
- " soaps by analysis—*see* Soaps, commercial.
- " soaps, calculated—*see* Calculations.
- Compound ethers, 3, 4, 15.
- " " saponification equivalent of, 158.
- " " synthesis of, 13, 17.
- Condensed ricinoleic acids—*see* Polymerised.
- Congealing temperatures—*see* Melting points.
- Consistency of elaidin formed—*see* Elaidin; *also* Classification according to chemical nature, &c., pp. 281-300.
- " of oils, &c., 47.
- " tester, Legler's, 139.
- Cooling pans (candle stearine), 366.
- Copper and nitric acid test, 137, 139.
- " compounds as driers, 314.
- " contained in glycerine, 515.
- " " in oils, 121-124.
- " soaps, use of, in refining, 263.
- " sulphate, use of, in refining, 256, 263.
- " test for drying oils (Hübl), 133.
- " test for sugar in soaps, 505.
- Coppers for soap boiling—*see* Kettles.
- Coprah (copra), crushing and grinding appliances, 219-221, 224.
- Correction for anhydro derivatives, 170.
- " " errors of hydrostatic balance and hydrometer, 82-84.
- " " free fatty acids, &c., 170.
- " " impurities (alkalinity), 419.
- " " temperature (specific gravity), 79.
- Corrosion of bearings, &c.—*see* Acids, free fatty (detrimental effects of), and Acids (mineral).
- " " iron by fatty acids, 277.
- Cosmetics, oils used in preparation of, 302.
- Cottonseed, decortication of, 224.
- " stearine—*see* Stearine (cottonseed).
- " utilisation of a ton of, 304.
- Cowles, candle moulding machines, 104
- Cracklings, 246.
- Crampton, expansion of oils, 93.
- Creosote oils, 2, 451.
- Cresol, 6, 16.
- Cressonnières', A. and E. dea, drying soap, 447.
- Crocodile fat, 299.
- Cross and Bevan, melting point determination, 64.
- Crotonol, 288.
- Cruciferous plants, sulphurised oils from, 123, 154.
- Crushing rolls, 215, 218-220.
- Crutching (soap), 438-440
- Crystallisation, fractional, separation by, 112.
- " from solvents, 23.
- " of separation cake—*see* Separation cake.
- Crystallising pans (stearine), 367.
- Culinary uses of oils and fats—*see* Oils (cooking).
- Cupreol, 16.
- Curbs, 432, 433, 453, 469.
- Curd soap—*see* Soapmaking.
- Curriers' grease, 326.

D

- DALIGAN'S process (tallow, &c.), 74.
- D'Arcet's sulphuric acid process, 249.
- Dechan, pharmaceutical soaps, 510.
- Decolorising of oils—*see* Oils, bleaching of.
- Decomposing pan, stearine, 365.
- Decortication of seeds, &c., 223-225.
- " " Dudley and Perry's chemical process, 225.
- Deering, free acids in rancid tallow, 355.
- Dègras, 336.
- Degrees (alkalies), English, French, and German, 420, 421.
- " Burstyn's, 119.
- " Centigrade, Reaumur, Fahrenheit, 58.
- Dehydration, formation of isoleic acid by, 29.
- " of oxystearic acids, 29, 39, 42, 46.
- " of ricinoleic acid, 36.
- Deitz, extraction apparatus, 235.
- Delphinum phocæna, 20.
- Density—*see* Specific gravity.
- Deodorising cokernut oil, 261, 310.
- " soaps, &c., 267—*see* Rancid; Noxious vapours.
- Descroizilles, degrees (alkali), 420.

- Destruction of noxious vapours by combustion, 247, 250.
 Destructive distillation—*see* Distillation.
 Determination of fat in seeds, &c.—*see* Yield.
 Detrimental effects of free fatty acids—*see* Acids (free fatty).
 Detrimental effects of free mineral acids—*see* Acids (mineral).
 Diagoneter, 53, 347.
 Diallyl, oxidised to an erythrol, 44.
 Dibromcamphor, 32.
 Dibromides of acids, &c., 27, 29-31, 41, 43, 44, 176.
 Dibromo substitution derivatives—*see* Substitution.
 Dichlorides of acids, &c., 26, 29, 31.
 Dichloro substitution derivatives—*see* Substitution.
 Dichromate, bleaching with—*see* Bichromate.
 Dieff and Reformatsky, ricinoleic acid, 40.
 Dierucin, 11.
 Dieterich, iodine number of linseed oil, 350.
 „ specific gravity of fats, 88, 355.
 Digester, for extracting bone fat, 252.
 „ Wilson's, for rendering tallow, &c., 250.
 Diglycerides, 10, 468.
 „ formed by action of sulphuric acid, 144-147.
 „ synthesis of, 11.
 Diglycerol, 8.
 Diiodides of acids, &c., 26, 179-186.
 Diiodo substitution derivatives—*see* Substitution.
 Dikafat—*see* Butters (vegetable).
 Diminution in density with rising temperature, 92-94.
 Dippel's oil, 2.
 Diricinolein sulphuric anhydride, 147.
 Disintegrating machines, 224.
 Dissolved impurities, 256.
 Distearates, 23.
 Distearin, 468.
 Distillation acetyl number, 198.
 „ destructive, 2, 3, 5.
 „ Heyl's apparatus, 234.
 „ of carbon disulphide solutions, 234-239, 254, 339.
 „ of castor oil, 20, 25, 40.
 „ of dioxystearic acid, 42, 46.
 „ of glycerine, 513-516.
 „ of oxystearic acid, 25.
 „ of ricinoleic acid, 36, 40.
 Distillation of spirit (transparent soap), 446.
 „ of turpentine spirit (Meincke's rosin soap), 473.
 „ under diminished pressure, 14, 20, 21, 25, 28, 29, 34, 36, 40, 41, 113.
 „ under diminished pressure; technical processes, 383.
 „ with superheated steam, 110, 113, 262, 271, 277, 278, 337, 513, 514.
 „ with superheated steam, plant used for, 382-386.
 „ with wet steam, 22, 112, 173-176—*see also* Reichert's test.
 Distilled grease (Yorkshire), 277.
 „ oleines—*see* Oleines (distilled).
 Dog fat, 299.
 Dogfish liver, extraction of oil from, 247.
 Dragon's blood, 19.
 Driers, 129, 262, 314-317.
 Dripping, 91, 303.
 „ tallow adulterated with, 354.
 Dry fusion, rendering animal fats by, 246.
 „ steam—*see* Steam.
 Drying soap, 438, 447.
 Dubbin, 326.
 Dubrunfaut, sulphuric acid process, 380.
 Dudley and Perry, chemical decortication, 225.
 Dugong blubber, extraction of oil from, 247.
 Dunn, air blast in soap boiling, 433.
 „ boiler (hydrated soaps, &c.), 463.
 Dussauce, ley tanks lined with lead, 412.
 Dutch liquid, 26.
 Dyer, linseed cake, 214.
 Dyestuffs for candles, 405.

E

- EARTH-NUT—*see* Oil (arachis).
 Earthwax—*see* Wax (mineral).
 Edgerunners, 215, 218-221.
 Edible uses of oils and fats, 302-312.
 Edinburgh wheel, 391.
 Effect, detrimental, of free fatty acids—*see* Acids (free fatty).
 „ of light on physical properties of oils—*see* Light (effect of).
 Efflux viscosity—*see* Viscosity.
 Egg, white of, used in clarifying candle stearine, 370.
 Elæococca vernicia—*see* Oil (Elæococca).

- Elaidin reaction, 28, 40, 341.
 " " methods of working, 137-139.
 " " solubility diminished by, 55.
 Elbow press, 202.
 Electrical conductivity, 53.
 " method (melting points), 65.
 Elevators, 221-225.
 Ellinger, Danish butter, 53.
 Ellwood, Valenta's test, 57.
 Enflourage, 302.
 Engine waste, grease from — *see* Grease.
 Engler, viscosimeter, 101.
 Engler and Kunkler, viscosimeter, 101.
 English degrees (alkali), 420.
 Entozoa present in inferior margarine, 303.
 Envelopes (oil pressing), 217, 221.
 Equivalent quantities of soda and potash, 425, 426.
 Error due to neglect of expansion, 77, 78.
 Errors, tables of, construction, 82-84.
 Equivalent, mean, of fatty acids—*see* Acids (fatty).
 " saponification — *see* Saponification equivalent.
 Erucin (erucic triglyceride), 11.
 Erythrol, 4.
 Erythrols from diallyl hydrocarbons by oxidation, 44.
 Eschwege seife, 461.
 Essential oils—*see* Oils (essential).
 Ester number (Esterzahl), 162, 195.
 Estrayer cylinder (oil press), 204.
 Ether as solvent for lead salts, 112, 128, 136, 356, 376, 501.
 " " oils, &c., 55, 119, 124, 231, 262, 273, 328, 359, 495-497, 501-503.
 Ether, petroleum — *see* Petroleum ether.
 Ethers, compound—*see* Compound ethers.
 Ethyl acetate, 4.
 " linolate, 34.
 Ethylene, action of chlorine on, 26.
 " diacetate, 4.
 Eugenol, 194.
 Evaporating point (lubricating oils), 325.
 Evrard, alkaline tallow rendering process, 249.
 Examination of oils, &c., general scheme for, 124.
 Expansion of glass, 77.
 " " correction for, 77, 78.
 " oils, &c., Allen's results, 92.
 " " Crampton's results, 93.
 " " Lohmann's results, 94.
 " " Wenzell's results, 93.
 Experimental laboratory press, 213.
 Expression in stages, 212.
 Extraction of oils by solvents, appliances for, 232-240.
 Extractive matters, fermentation, causes hydrolysis, 10.
- F**
- FAHRENHEIT scale, 57-59.
 Fahrion, boiled oil, 135.
 Fan (soapboiling), 433, 434, 460, 469.
 Farina as adulterant of fats, 123—*see* Starch.
 Fat, animal, class, 282, 298.
 " nature of, 1.
 " unsaponified, determination of, 119.
 Fats, animal, expression of oleines from, 299.
 " " from birds, 298.
 " " from milk (animal butters), 174, 298—*see also* Butter (cow's).
 " " from reptiles, 299.
 " " refining and bleaching, 254-268.
 " " rendering of, 245-251.
 " " tallow, lard, butter class, 282, 298.
 " vegetable—*see* Butters, vegetable.
 Fatty acids—*see* Acids, fatty.
 " matters in seeds, nuts, &c., 115, 237-244.
 Fawsitt, sulphur chloride and oils, 155.
 Ferrous sulphate as decolorising agent, 264, 269.
 " " used in soap mottling, 471.
 Fibre from cotton seeds, 304.
 Ficus gummiflua, 14.
 " rubiginosa, 16.
 Field, Leopold, candle nut oil, 287.
 " candles, &c., in the Roman period, 363.
 " lamp chimneys, 313.
 " soaps, 509.

- Field, Leopold, spermaceti, 360.
 ,, stearine plant, 369, 382.
 ,, wax bleaching, 266.
 Figging of soft soap, 459.
 Filling (soap)—*see* Soapmaking.
 Film test, 133, 351, 352.
 Filsinger, soap analysis, 494.
 Filter cake (red oils), 376, 377.
 Filtration of oils without extra pressure, 257, 264.
 Filter presses, 226-229.
 ,, use in clarifying expressed oils, 228, 254-257.
 ,, ,, in purifying red oils, 231, 376.
 Finkener on Dalican's method, 75.
 Firing point (ignition point), 329.
 First runnings, 304.
 Fish livers, extraction of oil from, 247.
 ,, manure from residues of fish oil extraction, 249.
 Fit (coarse or fine) of soap, 471.
 Fitted soap—*see* Soapmaking.
 Fixed oils—*see* Oils (fixed).
 Flambeau, 312, 362.
 Flashing point, 125-128.
 ,, of coaltar oils, &c., 328.
 ,, of lubricating oils, 325-329.
 ,, ,, insurance, 325.
 ,, of oleine from Yorkshire grease, 279.
 Flavour of oils, &c., 49.
 Flax plant, 349.
 Flaxen wicks, 362.
 Fleeces—*see* Wool.
 Fletcher, thermhydrometer, 80.
 Floating soaps, 441.
 Flour as adulterant of fats, 123—*see* Starch.
 ,, in beeswax, 359.
 Fluorescence, 50.
 Fob (fitted soap), 471.
 Foots, 115, 256, 259, 324.
 ,, avoidance of formation of, 228.
 ,, distillation of, 261, 383.
 ,, spermaceti, 261, 360.
 ,, utilisation of, 261, 324, 408.
 Formulæ, alkaline degrees, 421.
 ,, equivalent quantities of soda and potash, 426.
 ,, thermometer degrees, 58.
 Foxy colour developed, 265, 266, 356.
 Fractional crystallisation, 112.
 ,, distillation, 113.
 ,, precipitation, 112.
 ,, saturation, 112, 113.
 Frames (soapmaking), 434-437, 444.
 Frederking, oil boiling pan, 316.
 Free fatty acids—*see* Acids, free fatty.
 Free fire process of boiling oils, 315.
 ,, soap pans, 427.
 Freezing points—*see* Melting points.
 French degrees (alkali), 420.
 Fresenius, absorption of oxygen, 134.
 Friction coefficient, Mills, 107.
 ,, Poiseuille, 107.
 ,, Traube, 109.
 Fuel from cotton and sunflower seeds, 304, 305.
 Fullers' earth, use in refining oils, &c., 255.
 ,, grease, 272, 279.
 ,, ,, valuation of, 280.
 Fusel oil, use in woolscouring, 337.
 Fusel oils (fermentation oils)—*see* Oils (fusel).
 Fusing points—*see* Melting points.
 Fusion with alkalies—*see* Hydrogen.
- ### G
- GALIPOT resin, 88.
 Gay Lussac, candle material, 365.
 ,, degrees (alkali), 421.
 Geitel, stearolactone, 38, 145.
 ,, sulphuric acid and oils, 144.
 ,, —*see* Schepper and Geitel.
 Gelatin, removal of, from fish oils, &c., 256, 263.
 ,, use of, to remove colouring matters, &c., 263.
 Gellatley, spontaneous combustion, 132.
 Geranic aldehyde, 15.
 Geraniol, 15.
 Gerlach, specific gravity of potassium carbonate solutions, 419.
 ,, vaporimeter (glycerine valuation, 519.
 German degrees (alkali), 420.
 ,, sesamé—*see* Oil, Camelina.
 ,, soap process, 449, 472.
 Girard, solubility in alcohol, 54.
 Glacial acetic acid test—*see* Acid (acetic).
 Gladding's process, rosin in soap, 485, 501, 502.
 Glass, expansion of—*see* Expansion.
 Glässner, nitric acid test, 141.
 Glycerides, 3, 9.
 ,, determination of, in lubricants, 329.
 ,, hydrolysis of, in three stages, 10.
 ,, iodine absorbed by pure, 180.

- Glycerides, mixed—*see* Mixed glycerides.
- „ saponification equivalents of pure, 158.
- „ „ of, in three stages, 468.
- „ synthesis of, 11.
- Glycerine, manufacture of (glycerol extraction), 513-516.
- „ analysis and detection of impurities, 515.
- „ extraction from soap leys, 451, 468, 469, 541.
- „ „ from soap leys, composition, 514.
- „ „ from sweet waters, 513, 514.
- „ loss in sulphuric acid hydrolysis processes, 381.
- „ production in candlemaking processes, 311, 366, 373, 385, 513.
- „ production in soapmaking processes, 450, 451, 466-470.
- „ valuation, acetyl process, 8, 191, 516.
- „ „ bichromate process, 8, 516.
- „ „ David's process, 522.
- „ „ litharge „, 524.
- „ „ Muter's „, 523.
- „ „ oxalic acid process, 8, 519.
- „ „ by specific gravity, 516, 517.
- „ „ by tension of vapour, 518, 519.
- „ yield from ox fat, 311, 312.
- „ „ practical, from various glycerides, 521.
- „ „ theoretical, 162, 195.
- Glycerine soaps—*see* Soaps (special kinds).
- Glycerines (commercial products), 8, 110, 513.
- Glycerol, 4, 7, 110, 513. [144.
- „ action of sulphuric acid on,
- „ „ heaton—*see* Acrolein.
- „ as standard in viscosimetry, 101.
- „ calculated yield from triglycerides, 521.
- „ crystallised, 7, 514.
- „ formation during examination of oils, 124.
- „ „ from allylic alcohol, 44.
- Glycerol, formation on saponifying adulterated beeswax, 359.
- „ „ on saponifying adulterated sperm oil, 354.
- „ „ on saponifying Turkey red oils, as a test 333.
- „ physical properties of, 7.
- „ qualitative tests for, 8, 516.
- „ quantitative—*see* Glycerine, manufacture of (valuation).
- „ retained in cold process soaps, &c., 450, 456-466.
- „ „ calculations respecting, 464-466.
- Glycol, 4.
- „ from Carnauba wax, 5, 18.
- „ „ olefines by oxidation, 44.
- Goat's tallow—*see* Tallow.
- Goods, "killing" of, in soapmaking, 433, 468.
- „ rancid, deodorising soap made from, 267.
- Goose grease, 68, 184, 298, 299.
- Gossage, method of emptying soap pans, 434.
- Graf, theobromic acid, 22.
- Grain spirit fusel oils, 14.
- Graining soap—*see* Soapmaking.
- Granulating presscake—*see* Separation cake.
- Grape fusel oils, 20.
- Grease, birds, 298.
- „ bone—*see* Bone grease.
- „ curriers', 336.
- „ distilled, 277—*see* Distillation.
- „ engine waste, 236, 279, 324.
- „ from hot pressing—*see* Hot press.
- „ from silk soap suds, 279.
- „ fullers', 279, 280.
- „ horse, mare's—*see* Oils (horse).
- „ lubricating—*see* Lubricants.
- „ recovered, 262, 270-280.
- „ „ used in soapmaking, 450, 453.
- „ recovery by Yorkshire process, 272—*see* Yorkshire grease.
- „ „ by lime process, 271.
- „ trade refuse (tannery grease. &c.), 299.
- „ „ used in soapmaking, 409.
- „ Yorkshire—*see* Yorkshire grease.

- Greasy rags, spontaneous combustion of, 132, 133.
 Greaves, 246.
 Green liquor—*see* Chrome liquor recovery.
 Green oil (Yorkshire grease distillation), 277.
 Grills and Schroeder, liquid sulphur dioxide as solvent, 236.
 Grimshaw, phosphated soaps, 476.
 „ utilisation of cotton seeds, 304.
 Grittner and Szilazi, rosin in soap, 502.
 Grüger, dioxypalmitic acid, 44.
 Ground mica (antifriction), 324.
 Groundnut—*see* *Arachis* nuts and Oil (*arachis*).
 Ground plan of 16-press installation, 216.
 Gum arabic, Rideal, 108.
 „ benzoin, 19.
 Gumming of oils, 129, 322, 325.
 „ „ practical test of, 323.
 Gwynne, Jones, and Wilson, sulphuric acid process, 380.
- ### H
- HAGEMAN, soda crystals in oil refining, 260.
 Hagenbach, viscosity, 107.
 Hager, specific gravity of fats, 88, 355.
 Hairs, hair envelopes, 217, 221.
 Handpicking seeds, necessary to obtain standards, 213, 340, 350.
 Hartley, acid refining process, 259.
 „ manganese sulphate in refining, 260.
 Hartley and Blenkinsop, patent refining process, 263, 264, 315.
 Hauchecorne, nitric acid test, 140.
 Haussknecht, benoxylic acid, 45.
 „ brassaidic acid, 28.
 Hawes' boiler (cold process soap), 457, 463.
 Hazura, characteristic oxidation products, 128.
 „ oxidation of stearolic acid, 36—*see* Benedikt and Hazura; Bauer and Hazura.
 Hazura and Grüssner, glycerides in linseed oil, 350, 351.
 „ „ linolic acid, 35.
 „ „ linolic acid in olive oil, 344.
 „ „ oxidation of drying oil acids, 136.
 „ „ „ of ricinoleic acid, 40.
 Hazura and Grüssner, oxidation of stearolic acid, 45.
 „ „ rule concerning oxidation, 44.
 Head matter (whales), 360.
 Heat, coagulation of albuminous matter by, 255, 263.
 „ effect of, on oils—*see* Oils (effect of heat on).
 „ evolution with sulphuric acid—*see* Oils (heat evolution).
 Hehner, beeswax, 357, 358.
 „ glycerine valuation, 516, 522.
 „ number, 113, 157, 166-170, 195, 196, 341.
 Heintz, melting point tables, 71-74.
 Hell, hydrogen method, 13, 121.
 Hempen wicks, 362.
 Hersee, soap pump, 434.
 Hervieux and Bedard, waggon grease, 327.
 Hess, Yorkshire grease analysis, 276.
 Hexacetyl derivatives, 37.
 Hexbromides of fatty acids, 34-37, 176.
 Heyl, distillation apparatus, 234.
 Hippopotamus grease, 299.
 „ milk, 298.
 Hoffmeister, chilling baths, 67.
 Holde, improved flashing point apparatus, 127.
 „ iodine absorption of drying oils, 184, 351.
 „ oleorefractometer, 52.
 Holt, brassic acid, 29.
 Homologous acids, separation of, 112, 113.
 Homologues of linolic acid (supposed), 32, 34.
 Honig and Spitz, extraction apparatus, 120, 239.
 Hope, soap analysis, 494, 498, 499, 509.
 Horse grease, horse fat—*see* Oil (horse).
 „ power requisite in oil mill, 215-217.
 Hot baths, 61-65, 80, 95-101.
 Hot air bleaching processes—*see* Air.
 Hot press, 231, 368.
 „ cake, 368, 370, 375.
 Hübl, beeswax, 358.
 „ iodine test—*see* Iodine number.
 „ melting points, 71.
 „ modification of Livache's test, 133.
 Hübl and Stadler, rosin in soap, 502.
 Huiles d'enfer, 344.
 „ tournantes, 116, 344.
 Hulls from cotton seed, 304.

- Hurst**, efflux viscosity values, 105.
 ,, Valenta's test, 56, 57.
 ,, viscosimeter, 101.
 ,, Yorkshire grease, 276-279.
- Hyæna fat**, 21.
- Hydrated soaps**—see Soapmaking.
- Hydration of anhydrides, &c.**, 41-43, 45.
 ,, of isoleic acid, 38.
- Hydraulic filter press**—see Filter press.
 ,, presses, 207-212, 215-218.
- Hydriodic acid**, action on isoleic acid, 30.
 ,, ,, action on linolic acid, 34.
- Hydrocarbons**, 2, 3, 5, 54, 90.
 ,, detection in linseed oil, 352.
 ,, ,, in olive oil, 347.
 ,, ,, in rape oil, 349.
 ,, ,, in Turkey red oils, 335.
 ,, ,, in wax and spermaceti, 359, 361.
 ,, determination in lubricants, 329.
 ,, insoluble in glacial acetic acid, 57.
 ,, mineral, solid—see Cerasin, Ozokerite.
 ,, miscible with blown oils, 320, 321.
 ,, presence of, in distilled oleines, &c., 120, 258, 261, 274-278, 377, 378.
 ,, ,, in engine waste grease, 279.
 ,, saturated and unsaturated, 3, 26.
 ,, separation of, from oils, 119-124.
 ,, use of, in manufacture of lubricants, 322-329.
 ,, used as adulterants, 120, 121, 335, 347-349, 352.
- Hydrocarotin**, 18.
- Hydrochloric acid**, evolved from burning wax tapers, 267, 365.
 ,, ,, formed in Turkey red oil making, 331.
 ,, ,, removal of lime salts from bonefat by, 256.
 ,, ,, used in grease recovery, 271.
 ,, ,, ,, in Mège Mouries process, 308.
 ,, ,, ,, in oleic acid valuation, 376.
- Hydrochloric acid** used with bleaching powder, &c., in decolorising oils, &c., 264-266.
- Hydrogen**, atmosphere of, in cod liver oil extraction, 248.
 ,, evolved by fusion with alkalis, from acrylic acids, 24.
 ,, ,, from alcohols, 13, 121.
 ,, ,, from glycols, 18.
 ,, ,, from glycollic acids, 37.
 ,, nascent, as dechlorinising agent, 31, 35.
 ,, peroxide as bleaching agent, 264, 339, 359.
- Hydrogenation of acids**, 20, 26, 32, 34, 40.
 ,, aldehydes, 14, 15.
- Hydrolysis** accompanies rancidity, 10, 12, 114, 292.
 ,, but little effected by light, 131.
 ,, by superheated steam, 10, 110, 125, 261.
 ,, in autoclaves, &c., 373—see also Distillation.
 ,, of condensed ricinoleic acids, 146, 333.
 ,, of oils, &c., 7, 10, 12, 114, 116.
 ,, of soap solutions, 12, 23, 486-488.
 ,, of soap solutions, rate diminished by presence of alkali, 487.
 ,, of sulphuric acid compounds, 27, 29, 331, 333.
 ,, of Turkey red oils, 331-333.
 ,, water taken up during, 10, 275.
- Hydrometer**, 77.
 ,, scales, 84-86.
 ,, table of errors, construction of, 83.
- Hydrostatic balance**, 77-79, 81.
 ,, table of errors, construction of, 83.
- Hydroxylinolein**, 136, 137.

I

- ICELAND moss** in lard, 306.
- Ignition point**, 329.
- Illipè fat**—see Butters, vegetable.
- Impurities**, systematic examination for, 124.
- Incipient melting and solidifying points**—see Melting point.

- Increment in weight during drying of fatty acids, 113.
- Increment in weight during drying of oils, 133.
- Indicators in titration, 420—*see* Phenolphthalein, Titration, Cochineal, Litmus, Methyl orange.
- Indigo, used to tint soft soap, 459.
- Inner anhydrides, 30, 39.
- Insolation, effect of—*see* Light, effect of.
- Insoluble acid number, 168, 195, 341.
 „ fatty acids—*see* Acids, fatty, insoluble.
- Installation (16-press), plan of, 217.
- Insurance companies and lubricating oils, 325.
- Iodine candles, 407.
 „ number (iodine absorption), 26, 34, 157, 176-186, 341.
 „ „ as test of drying power, 133.
 „ „ effect of light on, 131.
 „ „ lessens as oxygen taken up, 42, 129, 135, 185.
 „ „ of free acids, 180, 184, 197, 356.
 „ „ of glyceride falls short of that of free fatty acid by about 4.5 per cent., 185, 197.
 „ „ of oils, determinations of, 181-184, 196.
- Iodo substitution derivatives—*see* Substitution.
- Irish moss (antifriction), 328.
- Iron, cast, less corroded by fatty acids than wrought iron, 277.
 „ salts, use in refining, 263.
 „ soaps—*see* Metallic soaps.
- Isocholesterol, 16, 17.
 „ and ethers in Yorkshire grease, 272-276.
- Isoglyceride theory, 12.
- Isomerides of dioxybenic acid, 28, 29, 44, 129.
 „ dioxystearic acid, 28, 30, 41, 43, 129.
 „ linolic acid, 32, 35.
 „ of oleic acid, 28, 29, 129.
 „ oxystearic acid, 29, 33, 39.
 „ oxystearosulphuric acid, 27, 30, 38.
 „ ricinoleic acid, 40, 41.
 „ trioxystearic acid, 40, 43, 44, 129.
- Isomerism of brassic and erucic acids, 28, 29.
 „ stereochemical, 29.
- J**
- JACKSON, African oils, 289.
- Japanese wax—*see* Wax (Japanese).
- Jean, adulteration of butter, 310.
 „ oleorefractometer readings, 51-53.
 „ thermoleometer, 151.
- Jellifying of soap solutions, 485.
- Johnson & Co., filter presses, 229.
- Juillard, Turkey red oils, 147, 330, 333.
- K**
- KAOLIN as adulterant, 123.
- Kauri gum admixed with thickened oils, &c., 142, 318.
- Keg lard, 306.
- Kerosene, 2, 5.
- Ketones, 3, 6.
- Kettles for boiling drying oil, 315, 316.
 „ for boiling soap, free fired, 426-428.
 „ for heating crushed seed, &c., 215, 221.
 „ heated by dry steam, 247, 428.
 „ „ by wet steam, 428.
 „ skimmer pipe for, 433.
 „ square, 433.
 „ various older forms of, 429-432.
- Kitchen grease, 299, 408.
 „ „ deodorising, 265.
 „ „ tallow adulterated with, 354.
- Kœttstorfer's test (Kœttstorfer number)—*see* Total acid number.
- Kidney fat (ox), 311.
- “Killing the goods,” 433, 468.
- Knab's superheated steam distillation plant, 382.
- Kohn, qualitative test for glycerol, 516.
- Krafft, ricinolic acid, 36.
 „ ricinic acid, 41.
- Krafft and Noerdlinger, brassic and elaidic acids, 28.
- Kingzett, glycerine extraction, 514.
- Kulp livers, extraction of oil from, 247.
- L**
- LABOUR requisite in oil mill, 215-218.
- Lach, candlenut oil, 287.
 „ French candlestearine plant, 386.
- Lactucerosol, 16.
- Lamp for carbon disulphide (disinfecting), 407.

- Lamps, 312, 313, 362.
 Langbeck, lanolin 339.
 Langlet, thermal aræometer, 82.
 Lanolin, 274, 336, 337-339.
 „ in soaps, 448.
 „ manufacture of, 337.
 „ sulphurised, 339.
 „ tests of quality of, 339.
 Lant Carpenter, lubricating oils, 325.
 „ soap analysis, 510.
 „ soap boiling, 470.
 „ sulphuric acid process, 381, 388.
 Lard, 21, 164, 299, 303-308.
 „ adulteration of, 306, 307.
 „ artificial, 307.
 „ damaged, used for soapmaking, 408.
 „ free fatty acids in, small when fresh, 307.
 „ iodine number of, 181-184, 307, 356.
 „ manufacture of, 306.
 „ melting point of, 68, 306, 307.
 „ oil—*see* Oil (lard).
 „ Reichert number of, 175.
 „ saponification equivalent of, 160, 307.
 „ solid suspended matters in, 123.
 „ solubility of, 56.
 „ specific gravity of, 88-93, 307.
 „ stearine (solar stearine) — *see* Stearine (lard).
 „ unsaponifiable constituents in, &c., 257, 307.
 „ vegetable, 305, 310.
 „ water contained in, 122, 307.
 Laurent, polarimeter, 50.
 Lauric aldehyde, 14.
 Laurin, lauric triglyceride, 11.
 Lead acetate, use in boiling oils, 262, 314.
 „ contained in oils, 121-124, 314.
 „ oxide as saponifying agent, 410.
 „ oxides as driers, 314.
 „ plasters, 410, 485.
 „ salts soluble in ether—*see* Ether as solvent.
 „ salts, use of, in refining, 256, 263.
 „ test (Livache's), 133.
 Leather currying, leather grease, 302, 336, 339.
 Leblanc process of alkali manufacture, 410.
 Lecithin, 121, 240, 259.
 „ determination of phosphorus in, 124, 240.
 Leeds, soap analysis, 494.
 Lefebre, oleometer, 79.
 Leffmann and Beam, Reichert number, 175.
 Legler, consistency tester, 139.
 Lenz, density of glycerol solution, 517.
 Lepenau, leptometer, 106.
 Leuner, bonefat extraction apparatus, 253.
 Lever presses, 199.
 Lever and Scott, carbon tetrachloride as solvent, 236.
 Levinstein, lanolin, 339.
 Lewkowsitch, acetylation test and modification thereof, 189-191, 198.
 „ distillation under diminished pressure, 383.
 „ rosin in soap, 502-504.
 „ Yorkshire grease, 272.
 „ „ „ analysis of, 274.
 Leys, alkalinity of—*see* Alkalinity.
 „ calculations respecting quantity and strength of—*see* Calculations.
 „ causticising—*see* Causticising.
 „ spent—*see* Soapmaking, Glycerine manufacture.
 „ use of, in soapmaking—*see* Soapmaking.
 Liechti and Suida, sulphuric acid and oils, 144.
 Liebig, distillation of acids, fractional saturation, 112.
 Light coaltar oils, 2.
 „ petroleum distillate—*see* Petroleum ether.
 Light, effect of, on oils—*see* Oils, effect of light on.
 „ facilitates air bleaching of wax, 268, 269.
 „ polarised (polariscope), 17, 50, 347, 352.
 „ „ sugar valuation in soap, 505.
 Limburg cheese, 20.
 Lime, use of, in causticising alkalies—*see* Causticising.
 „ „ making railway grease, 327.
 „ „ recovering grease, 270.
 „ „ refining oils, 256, 261.
 „ „ stearine manufacture, 365, 369.
 Lime rosin soap (railway grease), 327.
 Lime soap (grease recovery), 271.
 „ in candlemaking—*see* Candle stearine.
 „ in lard, 307.
 „ in lubricants, 324, 327, 328.

Limpach, stearolic acid, 36.
 Linoleum, 302, 318, 319.
 Linolic anhydride, 125.
 Linolin (linolic triglyceride), 134, 139.
 Linoxyn, 134, 136.
 Linseed cake—*see* Oilcake
 Linseed, sources of, 349.
 „ usually mixed with hempseed, 349.
 Lint, 304.
 Litmus as indicator, 420.
 Liquid waxes—*see* Waxes.
 Litharge as drier—*see* Driers.
 Livache, comparative action of driers, 314.
 Livache's test, 133, 351, 352.
 Livers, fish and shark, &c., extraction of oil from, 247.
 Loading (soap)—*see* Soapmaking.
 Løwe, melting points, 65.
 Lohmann, expansion, 93.
 Lubricants, analysis of, 328-330.
 „ coarse, 271, 280, 324, 326-328.
 „ corrosion by free acids in, 115, 260, 322.
 „ for hot rollers (pitch from Yorkshire grease), 277.
 „ greases (cart, carriage, wagon, railway grease, anti-friction grease, &c.), 325-329, 409.
 „ materials used for, 302, 321-328, 339.
 „ use of blown oils for, 320.
 „ viscosity of—*see* Viscosity.
 Lubrication, 5, 48.
 Lunge and Hurter, Beaumé scale, 86.
 „ „ specific gravity of alkaline leys, 416-418.
 Lupeol, 17, 259.

M

M'NAUGHT, pendulum machine, 94.
 Magma (grease recovery), 271, 272.
 Magnesia as saponifying agent, 379, 410.
 „ calcined, use of, in refining, 256, 261.
 Magnesium soaps, 121.
 Manganese compounds, use of, as driers, 314, 315.
 „ dioxide, use of, in bleaching, 268.
 „ salts, use of, in refining, 256, 260-264.
 Mangold, glycerine valuation, 521.
 Mannitol, 5.

Mansbridge, analysis of Yorkshire grease, 275, 276.
 Manteau Isabelle (mottled soap), 472.
 Manure from fish oil extraction residues, 249.
 „ scraps from ox fat, 311, 312.
 „ sludge from suds and sud-cake, 271, 272.
 Mare's grease—*see* Oil (horse).
 Margarin, glyceride of artificial margaric acid, 21, 22, 110, 309.
 Margarine (Oleomargarine. Butterine, Artificial butter, Dutch butter, Bosch, Butter substitutes), 22, 114, 299, 305, 308-312.
 „ cokernut and palmtree oils in, 310.
 „ Hehner number, 166, 310.
 „ iodine number, 181, 184, 310.
 „ manufacture, 246, 247, 308-312.
 „ manufacture by Mège Mouries process, 308.
 „ origin of name, 308.
 „ Reichert number, 173, 174, 310.
 „ specific gravity, 88, 91.
 „ total acid number and saponification equivalent, 159.
 „ use of oleorefractometer in detecting, 53.
 „ vegetable, 305.
 Marine soap—*see* Soapmaking.
 Maritime alkali—*see* Barilla.
 Marix, distillation under diminished pressure, 383.
 Marrow, 21.
 Massie, nitric acid test, 141.
 Maumené's test—*see* Oils (heat evolution).
 Meal as adulterant, 123.
 Mean equivalent—*see* Acids, fatty, (mean equivalent).
 Meats from cotton seed, 304.
 Mechanical viscosity testers, 94.
 Mège Mouries process, 308.
 Meinecke's process (rosin soap), 473.
 Meissl, Reichert number, 53, 174.
 Melting points (Congealing. Solidification, Fusing, Freezing points), acetic acid series, 20.
 „ acrylic acid series, 25.
 „ alcohols, 14.
 „ candlestearine, 370, 375, 377.
 „ cholesterol and allied bodies, 17.
 „ congealing of lubricants, 67, 325.

- Melting points, determination of,** 60-67.
 „ distilled fatty acids, 384.
 „ erucic and brassic acid derivatives, 29.
 „ mixed fatty acids, 69-76, 341.
 „ oils and fats, &c., 67-69.
 „ polyhydroxylated stearic acids, 43.
 „ propiolic acids, 32.
 „ synthetic triglycerides, 11.
- Mercuric bromide, use of, in Hübl's test,** 179.
 „ nitrate, colour test, 151.
- Mercury and nitric acid test,** 138.
- Merryweather & Sons, improved dry heat rendering arrangement,** 247.
- Metallic salts, used in refining oils,** 262, 263.
 „ soaps, detection in olive oil, 347.
 „ „ formed in paint, 135.
 „ „ in lubricants, 324, 328.
 „ „ in oils, &c., 121-124, 315, 324, 485.
 „ „ in ordinary soaps, 410.
 „ „ iron soap in mottling, 472.
 „ „ isolation of metallic constituent (analysis), 328.
- Methyl esters (brassic and erucic),** 29.
 „ number (methyl iodide test), 157, 191-194, 196.
 „ orange as indicator, 420, 497, 507.
- Methylic ethers,** 5.
- Mica (antifriiction),** 324, 328.
- Michaud Frères, glycerine manufacture,** 515.
- Milk fats, composition unlike that of body fats,** 298.
 „ Reichert number, 174.
- Milling machinery (toilet soaps),** 446-448.
- Mills, viscosity,** 107, 108.
 „ W., oil bleaching, 264.
- Mills and Akett, Mills and Snodgrass, bromine absorption,** 177.
- Milly, de, candle material,** 365.
 „ wicks, 394.
- Mineral acids, injurious effect of—see Acids, mineral.**
- Möellon,** 336.
- Möller, improved cod liver oil extraction process,** 248.
- Moinier and Bontigny, candle stearine,** 369.
- Monoglycerides, 10.**
 „ synthesis of, 11.
- Morawski and Demski, iodine absorption,** 184.
- Morfit, oleine soap process,** 453.
 „ steam series of soap pans, 432.
 „ steam twirl, 428, 429.
 „ „ use in making lubricating grease, 325.
 „ „ use in making resin-ate of soda, 453.
- Mortars (mortuary candles),** 406.
- Mottled soaps—see Soapmaking.**
- Moulding, Moulding machine (oil pressing),** 215, 221-223.
- Mountain ash berries,** 32.
- Mucilage (vegetable mucus), determination of,** 118-123.
 „ „ removal from oils—see Oils (clarification).
- Müller-Jacobs, sulphuric acid and oils,** 144.
- Muirhead and Alder Wright, zinc chloride and oils,** 141.
- Mulder, drying oils,** 134, 136.
- Muntz, thermal areometer,** 82.
- Muter, colour reactions,** 142.
 „ determination of oleic acid, 376.
 „ olein tube, 376.
 „ specific gravities, 88.
- Muter and Koningh, separation of fatty acids,** 307, 356.
- Mutton tallow—see Tallow.**
- Myricin (myricylic palmitate),** 4, 358, 359.
- Myristic aldehyde,** 14.
- Myristin (myristic triglyceride),** 11.

N

- NATRON,** 409, 449.
- Natural naphtha—see Oils (mineral).**
- Negative alkalinity,** 498, 499.
- Negur (negre, nigre, nigger) of fitted soaps,** 471.
- Neill & Sons, modern soap coppers,** 433.
 „ remelting pans, 441.
- Neutral oil (Yorkshire grease),** 276-279.
- Neutralisation number of fatty acids,** 164, 169.
 „ „ mixed acids, calculation of composition from, 172.
- Nightlights,** 312, 402.
 „ manufacture of, 406.
- Niin fat, Niin wax,** 302.
- Nitric acid test,** 139, 153, 294, 341.

- Nitric acid as standard acid in soap analysis, 497.
 ,, use of in wax bleaching 284, 285.
- Nitrous acid test—*see* Elaidin reaction.
- Nocciuolo (olive marc), 343.
- Noerdlinger, oilcakes, 114, 214.
 ,, refining oil, 263.
 ,, *see* Krafft and Noerdlinger.
- Norton and Richardson, linolic acid, 34.
- Noxious smells evolved in rendering animal fats, 247, 249.
- Number, acetyl—*see* Acetylation test.
 ,, ester—*see* Ester number.
 ,, free acid—*see* Acids, free fatty.
 ,, Hehner—*see* Hehner number.
 ,, Hübl—*see* Iodine number.
 ,, iodine—*see* Iodine number.
 ,, insoluble acid—*see* Insoluble acid number.
 ,, Kættstorfer—*see* Total acid number.
 ,, methyl—*see* Methyl number.
 ,, neutralisation—*see* Neutralisation number.
 ,, Reichert—*see* Reichert number.
 ,, saponification—*see* Total acid number.
 ,, soluble acid—*see* Soluble acid number.
 ,, total acid—*see* Total acid number.
 ,, volatile acid—*see* Volatile acid number.
- Nuisance in rendering fats—*see* Noxious smells.
- Nutmeg butter—*see* Oil (nutmeg).
- Nuts strung together used as candles, 363.
 ,, yield of fat from various kinds of, 241-244.
- O**
- OAKBARK infusion, use of, in refining, 256, 263.
- Octylic ethers, 5, 20.
- Odour of oils, &c., 49, 341.
 ,, rancid, removal of—*see* Rancid, Rancidity.
- Enanthol (α-nanthic aldehyde), action of acetic anhydride on, 25.
 ,, formed by heating castor oil, 40.
 ,, hydrogenised to heptylic alcohol, 14.
- Enanthol, oxidised to heptocic acid, 20.
- Oil. For the specific gravity and other physical properties of each oil severally, *vide* Chaps. iv., v. (pp. 47-109).
 ,, For the chemical properties and reactions, *vide* Chaps. vi., vii., viii. (pp. 110-198).
 ,, acajou—*see* Oil (cashew).
 ,, adul, 288.
 ,, alligator pear (avocado oil, persea fat), 296.
 ,, almond, 3, 19, 241, 257, 283.
 ,, ,, class, 281, 282.
 ,, ,, detection of adulterations, 347.
 ,, anchovy, 294.
 ,, angelica, 37.
 ,, anise, 192, 194.
 ,, apricot kernel, 283.
 ,, American walnut—*see* Oil (hickory nut).
 ,, arachis (earthnut, groundnut, peanut), 21, 25, 241, 258, 283.
 ,, ,, adulteration of, 347.
 ,, ,, detection of, in olive oil, 344.
 ,, ,, doubt as to existence of hypogæic acid in, 24, 111.
 ,, ,, natural variations in composition of, 111.
 ,, ,, relative price of, 342.
 ,, ,, tests for, in olive oil, 344.
 ,, ,, use of, in soapmaking—*see* Soapmaking.
 ,, ,, used as lubricant, 322.
 ,, arctic sperm—*see* Oil (doegling).
 ,, areca nut, 241.
 ,, argan, 288.
 ,, assai—*see* Butters, vegetable (Para butter).
 ,, avocado, 296.
 ,, bankulnut—*see* Oil (candle nut).
 ,, beechnut (beechmast) 241, 283.
 ,, belladonna seeds, 241.
 ,, ben (behen), 21, 25, 241, 283.
 ,, ,, detection of adulterations, 347.
 ,, benné—*see* Oil (sesamé).
 ,, bitter apple—*see* Oil (colocynth).
 ,, blackfish, 293.
 ,, bladdernut, 288.
 ,, boma nut, 288.
 ,, bone—*see* Bone fat.
 ,, bottlenose whale—*see* Oil (doegling).
 ,, brazil nut (castanha nut), 241, 242, 288.
 ,, breadnut, 289.

- Oil, cabbage, 115.
 ,, calabar bean (poon seed, dilo, domba, pinnay, tamanu oil; poona fat, tacamahac fat), 241, 291, 296.
 ,, camelina (German sesamé, gold of pleasure), 241, 286.
 ,, ,, ,, tests for sulphur in, 123.
 ,, ,, ,, use in soapmaking—*see* Soapmaking.
 ,, canary—*see* Oil (Java nut).
 ,, candle nut (bankulnut, kekune), 241, 287.
 ,, carapa nut (crabwood nut oil, touloucoona oil, coundi oil, andiroba fat), 242, 296.
 ,, caryocar, 297.
 ,, cashew (acajou), 241, 289.
 ,, cassia, 19.
 ,, castanha—*see* Oil (brazil nut).
 ,, castor, 14, 20, 25, 43, 241, 285.
 ,, ,, action of sulphuric acid—*see* Oils (Turkey red).
 ,, ,, ,, zinc chloride on, 141.
 ,, ,, blown, 321.
 ,, ,, class, 281, 284.
 ,, ,, effect of exposure to air, 136.
 ,, ,, ,, heat on, 40.
 ,, ,, extraction by hot water process, 200.
 ,, ,, relative price of, 342.
 ,, ,, soap—*see* Soapmaking.
 ,, ,, soluble, 188, 321—*see* Oils (Turkey red).
 ,, ,, use in soapmaking, 408.
 ,, centaury, 242.
 ,, chamomile, 14, 25.
 ,, charlock, 241.
 ,, chaulmoogra, 20, 242, 297.
 ,, cherry kernel, 283.
 ,, chinese cabbage, 284, 348.
 ,, chironji, 242, 289.
 ,, cinnamon, 19.
 ,, cloves, 194.
 ,, cod (lubricating), 330.
 ,, cod fish and cod liver, 257, 258, 294.
 ,, ,, ,, extraction of, 247, 248.
 ,, ,, ,, extraction of, exclusion of air during, 248.
 ,, ,, ,, relative price of, 342—*see* Oils (liver, fish liver).
 ,, ,, ,, used for soapmaking—*see* Soapmaking.
 ,, cokernut, 20, 241, 257, 258, 295.
 Oil, cokernut, deodorising rancid, 261, 310.
 ,, ,, separation of coker stearine from, 231, 305—*see* Stearine (cokernut).
 ,, ,, spelling of, 3.
 ,, ,, use in soapmaking—*see* Soapmaking.
 ,, colocynth (bitter apple, 241, 288.
 ,, colza (cole, cole seed, kohlsaas), 348—*see* Oil (rape).
 ,, combo nut, 242.
 ,, copra (coprah)—*see* Oil (cokernut).
 ,, corn poppy, 242.
 ,, cotton seed, 241, 257, 258, 286.
 ,, ,, absorption of oxygen by, 330.
 ,, ,, action of sulphuric acid on—*see* Oils (Turkey red).
 ,, ,, adulteration of, 347.
 ,, ,, adulteration of lard with, 306-308.
 ,, ,, as lubricant, 322, 325.
 ,, ,, Becchi's test for—*see* Becchi's test.
 ,, ,, blown, 319.
 ,, ,, clarifying and refining, 255-263.
 ,, ,, class, 281, 286.
 ,, ,, refined, use as edible and cooking oil, and as adulterant of salad oils, 267, 304.
 ,, ,, relative price of, 342.
 ,, ,, use in soapmaking—*see* Soapmaking.
 ,, ,, utilisation of a ton of cotton seeds, 304.
 ,, coumu nut (coumu butter), 289, 297.
 ,, cow parsnep (heracleum), 5, 14, 20.
 ,, crabwood nut—*see* Oil (carapa nut).
 ,, cress seed, 241, 286.
 ,, croton, 20, 25, 287.
 ,, curcas (purqueira, purgir, jatroph), 20, 285.
 ,, datura (stramonium seed), 21, 244.
 ,, dilo, 291—*see* Oil (calabar bean).
 ,, doegling (bottlenose whale, arctic sperm), 3, 25, 258, 300, 360.
 ,, ,, doubt as to existence of doeglic acid in, 24.
 ,, ,, relative price of, 342.
 ,, ,, yields spermaceti of higher melting point than cachelot spermaceti, 360.

- Oil, dogfish liver, 247, 294.
 ,, dogwood berry, 288.
 ,, dolphin, 293, 301.
 ,, " bottlenose, yields spermaceti, 301.
 ,, domba, 291—*see* Oil (calabar bean).
 ,, dugong, 247, 293.
 ,, earth nut—*see* Oil (arachis).
 ,, egg—*see* Oil (hen's egg).
 ,, elæococca (Japanese wood, tung, wood oil), 32, 291.
 ,, " extremely rapid drying qualities, 291.
 ,, eucalyptus, 6, 178.
 ,, " medicated candles, 407.
 ,, euonymus—*see* Oil (spindlenut).
 ,, fever nut—*see* Butters, vegetable (Borneo tallow).
 ,, fish, class, 281, 292.
 ,, gamboge (gamboge butter), 242, 296.
 ,, garlic, 15.
 ,, gaultheria—*see* Oil (winter-green).
 ,, geranium, 3, 15.
 ,, German sesamé—*see* Oil (camelina).
 ,, gherkin seed, 288.
 ,, gingelly—*see* Oil (sesamé).
 ,, gold of pleasure—*see* Oil (camelina).
 ,, gourd seed—*see* Oil (pumpkin seed).
 ,, grape seed, 25, 242, 285.
 ,, green (Yorkshire grease distillation), 277.
 ,, groundnut—*see* Oil (arachis).
 ,, gundschit—*see* Oil (lallementia).
 ,, hammerfish, 294.
 ,, hazelnut, 242, 283.
 ,, hedge radish (hedge mustard), 284.
 ,, hempseed, 33, 35, 242, 257, 291.
 ,, " detection of, in linseed oil, 352, 353.
 ,, " use as cooking oil, 304.
 ,, " " in soft soapmaking—*see* Soapmaking.
 ,, " usually mixed with linseed oil, 349, 352.
 ,, henbane seed, 242.
 ,, hen's egg, 121, 298, 299, 408.
 ,, heracleum—*see* Oil (cowparsnep).
 ,, herring, 294.
 ,, hickory nut (American walnut oil), 242, 289, 291.
 ,, holly seed, 242.
 ,, horned poppy—*see* Oil (yellow-horn poppy).
 Oil, horse (horse grease, horse fat, mare's grease), 286, 299.
 ,, " deodorising, 465—*see* Rancid.
 ,, " use in soapmaking, 408.
 ,, horsefoot, 286.
 ,, horsechestnut, 242, 238.
 ,, Indian cress, 242.
 ,, Japanese wood—*see* Oil (elæococca).
 ,, Japan fish, 342.
 ,, jatropha—*see* Oil (curcas).
 ,, Java nut, Java almond (canary oil), 242, 296.
 ,, kekune—*see* Oil (candle nut).
 ,, kulp liver, 247, 294.
 ,, laintlaintain seed, 289.
 ,, lallementia (gundschit), 242, 291.
 ,, lard, 231, 286, 307.
 ,, " class, 281, 285.
 ,, " relative tendency to gumming, 323.
 ,, " used as lubricant, 322, 325.
 ,, laurel berry—*see* Butters, vegetable (laurel).
 ,, lettuce seed, 243.
 ,, linden seed, 243.
 ,, ling liver, 178.
 ,, linseed, 32-34, 243, 257, 258, 291.
 ,, " acid process for refining, 259.
 ,, " adulterations of, 351, 352.
 ,, " boiled, 262, 313-318.
 ,, " class, 281, 290.
 ,, " film test, Livache's test, 133, 351.
 ,, " iodine number, 351 (*see* Iodine number).
 ,, " pure, only obtainable by handpicking, 350.
 ,, " relative price of, 342.
 ,, " " tendency to gumming, 323.
 ,, " use as cooking oil, 304.
 ,, " " in soft soapmaking—*see* Soapmaking.
 ,, " various glycerides contained in, 350, 351.
 ,, liver class, 281, 292, 294.
 ,, louar, 294.
 ,, mabo nuts, 289.
 ,, maccassar, 184, 297.
 ,, madia, 243, 286.
 ,, maize, 243, 286.
 ,, malabar, 294.
 ,, malaka, 289.
 ,, manatee, 293.
 ,, mango seeds, 289.
 ,, mangosteen—*see* Butters, vegetable (goa butter).

- Oil, margosa—*see* Oil (zedrach).
 ,, menhaden (porgie), 249, 258, 294.
 ,, ,, relative price of, 342.
 ,, meni seed, 289.
 ,, morse, 293.
 ,, m'poga nut, 289.
 ,, mustard, 15, 21, 25, 243, 234, 348.
 ,, ,, tests for sulphur in, 123.
 ,, neat's foot, 286, 298.
 ,, ,, as lubricant, 322, 325.
 ,, ,, relative price of, 342.
 ,, nettle seed, 243.
 ,, neutral (Yorkshire grease), 276-279.
 ,, niger seed (ramtil), 243, 286, 408.
 ,, ,, relative price of, 342.
 ,, night shade seed, 243.
 ,, niko nut, 289.
 ,, nimb (neem)—*see* Oil (zedrach).
 ,, nut (walnut), 243, 291.
 ,, nutmeg, 20, 243, 295.
 ,, odal, 288.
 ,, olive, 243, 257, 258, 283, 322.
 ,, ,, absorption of oxygen by, 330.
 ,, ,, action of sulphuric acid on—*see* Oils (Turkey red).
 ,, ,, adulterations of, 344-347.
 ,, ,, as lubricant, 326.
 ,, ,, class, 281, 282.
 ,, ,, extraction by hot water process, 200.
 ,, ,, relative price of, 342.
 ,, ,, relative tendency to gumming, 323.
 ,, ,, sources and production of, 342-344.
 ,, ,, taste improved by presence of free acids, 116.
 ,, ,, used for soapmaking—*see* Soapmaking.
 ,, olive kernel, 243, 343.
 ,, ,, extraction of, 343.
 ,, oolachan, 294.
 ,, oepochala, 288, 289.
 ,, owala, 288, 289.
 ,, palm (palm butter), 21, 243, 257, 295, 322.
 ,, ,, bleaching processes, 264, 265.
 ,, ,, as candle material—*see* Candle stearine.
 ,, ,, extraction of, by hot water process, 200.
 ,, ,, use in soapmaking—*see* Soapmaking.
 ,, palm kernel (palm nut), 20, 243, 295.
 ,, ,, extraction by solvents, 200.
 ,, ,, use in soapmaking—*see* Soapmaking.
 Oil, pea, 121, 259.
 ,, peach kernel, 243, 283.
 ,, peanut—*see* Oil (arachis).
 ,, pelargonium, 20.
 ,, pilchard, 161, 294.
 ,, pine—*see* Oil (red pine).
 ,, pinnay, 291—*see* Oil (calabar bean).
 ,, piquia (pekea), 297.
 ,, pistachio nut, 244, 289.
 ,, plum kernel, 283.
 ,, poppy seed, 33, 243, 257, 291.
 ,, ,, relative price of, 342.
 ,, ,, use as cooking oil, 304.
 ,, ,, in soft soapmaking—*see* Soapmaking.
 ,, porpoise (Delphinus phocæna oil), 247, 293.
 ,, ,, contains valerian, 301.
 ,, ponga—*see* Butters, vegetable (karanja butter).
 ,, poon seed—*see* Oil (calabar bean).
 ,, poondi—*see* Butters, vegetable (karanja butter).
 ,, porgie—*see* Oil (menhaden).
 ,, pumpkin seed (gourd seed), 243, 288.
 ,, purgir nut (purqueira, jatropa, curcas)—*see* Oil (curcas).
 ,, radish seed, 244.
 ,, ramtil—*see* Oil (niger seed).
 ,, ray liver, 294.
 ,, rape (colza), 21, 25, 49, 257-259, 284, 313, 322.
 ,, ,, absorption of oxygen by, 330.
 ,, ,, adulteration of, 349.
 ,, ,, as standard of viscosity, 101, 349.
 ,, ,, blown, 319, 320.
 ,, ,, class, 281, 284.
 ,, ,, fatty acids and glycerides contained in, 11, 41.
 ,, ,, injurious effects of free acids on, 115, 313.
 ,, ,, insoluble in acetic acid, 55, 349.
 ,, ,, refining of—*see* Oils, refining.
 ,, ,, relative price of, 342.
 ,, ,, tendency to gumming, 323.
 ,, ,, tests for sulphur in, 123.
 ,, ,, used for soapmaking, 408.
 ,, ,, yield of, 241, 348.
 ,, raps (rapsamen), 348.
 ,, red pine seed (pine oil, pinaster oil), 244, 287.
 ,, rosemary, 15.
 ,, rosin—*see* Rosin oils.
 ,, rübsen, 348.

- Oil, rue, 3, 14, 20.
 ,, safflower seed, 244.
 ,, sanitas, 6, 477.
 ,, sapucaja nuts, 244.
 ,, sardine, 294.
 ,, Scotch fir seeds, 244.
 ,, seal, 247, 258, 293, 303.
 ,, ,, relative price of, 342.
 ,, ,, used for soapmaking—*see* Soapmaking.
 ,, sesamé (gingelly, benné, til oil), 244, 286.
 ,, ,, Baudoin's sugar test for—*see* Sugar test.
 ,, ,, class, 281, 286.
 ,, ,, detection of adulterations in, 347.
 ,, ,, relative price of, 342.
 ,, ,, used for soapmaking, 408.
 ,, shark, shark's liver, 247, 294, 408.
 ,, sheep's trotter, 52, 286, 298.
 ,, soap berry—*see* Butters, vegetable (soap berry).
 ,, soja bean, 287.
 ,, sperm, 3, 14, 258, 313.
 ,, ,, adulteration of, 353.
 ,, ,, as lubricant, 322-325.
 ,, ,, blown, 320.
 ,, ,, class, 282, 299.
 ,, ,, deposits spermaceti, 300, 353.
 ,, ,, relative tendency to gumming, 323.
 ,, ,, sources, 300, 353.
 ,, spindlenut (eunymus), 244, 288.
 ,, spirit (Yorkshire grease distillation), 277, 278.
 ,, sprat, 294.
 ,, spring poppy seed, 244.
 ,, spruce fir seed, 244.
 ,, spurge, 244.
 ,, stramonium seeds—*see* Oil (datura).
 ,, sunflower, 244, 286, 304, 408.
 ,, ,, production in Russia, 305.
 ,, tacamahac (tacamahac fat)—*see* Oil (calabar bean).
 ,, tallow, 231, 285, 286.
 ,, tamanu, 291—*see* Oil (calabar bean).
 ,, tansy, 3.
 ,, tea seed, 244, 283.
 ,, thistle seed, 244.
 ,, til—*see* Oil (sesamé).
 ,, tobacco seed, 244, 291.
 ,, touloucoona—*see* Oil (carapanut).
 ,, train—*see* Oil (whale).
 ,, tung, 291—*see* Oil (elæococca).
 ,, tunny, 294.
 ,, turpentine, 6, 25.
- Oil, turpentine, distilled off in Meinel's process, 473.
 ,, ,, facilitates air bleaching of wax, 269, 359.
 ,, ,, oxidation of, 477.
 ,, ,, solvent for manganese salts as driers, 315.
 ,, ungnadia, 244.
 ,, valerian, 15.
 ,, valve (valveoline), 330.
 ,, walnut—*see* Oil (nut).
 ,, walrus, 293.
 ,, watermelon seed, 244, 288.
 ,, weld seed, 244, 291.
 ,, whale (train), 247, 258, 293, 303, 322.
 ,, ,, class, 281, 292, 293.
 ,, ,, communicates unpleasant smell to soft soap, 459.
 ,, ,, relative price of, 342.
 ,, ,, used for soapmaking—*see* Soapmaking.
 ,, wild radish seed, 244.
 ,, wintergreen (gaultheria), 3, 5, 14, 19, 192.
 ,, wood (elæococca, Japanese wood),—*see* Oil (elæococca).
 ,, wool (from Yorkshire grease distillation), 279.
 ,, yellow horn poppy, 242.
 ,, zedrach (margosa, nimb, neem oil, veppam fat), 297.
- Oil baths for tempering metals, 302.
 Oilcake parings, use in clarifying oils, 255, 256.
 Oilcakes, 114, 211-214, 303-305.
 ,, acrid, from mustard seed, 349.
 ,, composition of, 213-214.
 ,, cotton seed, 212, 214, 304.
 ,, dimensions and weight of, 211.
 ,, fatty matters contained in, 115, 213-217.
 ,, free fatty acids contained in, 115, 214.
 ,, sunflower, superior to hemp and rape, 305.
- Oil lamps—*see* Lamps.
 Oil mill plant, 214-229.
 ,, used in olive oil production, 200, 343.
- Oils, absorption of oxygen by—*see* Absorption.
 ,, acetylation test for—*see* Acetylation test.
 ,, adulteration of, 340-361.
 ,, animal, 281, 282, 285, 292, 298, 299, 325.
 ,, ,, do not yield sativic acid, 291.

- Oils, anthracene—*see* Anthracene.
- „ Benedikt and Ulzer's test—*see* Acetylation test.
- „ blackfish, 293.
- „ bleaching of, 263-268.
- „ „ partly effected by precipitation of mucilage, &c., 263
- „ blown, 42, 90, 125, 130.
- „ „ chemical changes during manufacture of, 319-321.
- „ „ manufacture of, 264, 319.
- „ blubber—*see* Oils (cetacean).
- „ body of—*see* Viscosity.
- „ boiled—*see* Oils, drying (boiling of).
- „ bone—*see* Bone fat,
- „ bromine absorption of, 176-179.
- „ burning (lamp) oils), 2, 5, 302, 312.
- „ „ injurious effect of free acid on, 116, 260, 313.
- „ cetacean (blubber oils, train oils), 6, 113, 116, 292, 293, 299, 360.
- „ „ extraction of, 247.
- „ „ from toothed whales yield spermaceti, 293, 300, 301.
- „ „ separation of alcoholiform constituents from, 121.
- „ „ separation of spermaceti from, 300, 301, 360.
- „ characteristic oxidation products of, 128.
- „ chemical changes during drying of, 134-137.
- „ clarification of, by chemical processes, 254-263, 349.
- „ „ by filter presses and ordinary filters, 228, 255, 257.
- „ „ by standing in contact with water, 344.
- „ classification of—*see* Classification.
- „ cleansing of—*see* Oils (refining).
- „ coaltar, 2, 5, 50, 328.
- „ cod, 294—*see* Oil (codfish, cod liver).
- „ cohesion figures of—*see* Cohesion figures.
- „ cold drawn, 114, 212.
- „ colour of—*see* Colour.
- „ „ reactions of—*see* Colour reactions.
- „ congealing point of—*see* Melting points.
- Oils, cooking, 302-304.
- „ creosote, 2, 328.
- „ cylinder, 105, 128, 324.
- „ dead, 324, 328.
- „ decolorising of—*see* Oils, bleaching of.
- „ dissolved impurities, 256.
- „ dolphin, 293.
- „ drying, 32, 33, 55.
- „ „ boiling of, by air blowing process, 314-316.
- „ „ „ by free fire process, 314, 315.
- „ „ „ by oxygen process, 321.
- „ „ class, 281, 290.
- „ „ decolorising high class, 268.
- „ „ film test, Livache's test, 133.
- „ „ present in nondrying oils in small quantity, 185, 282, 344.
- „ „ relative proportions of different glycerides in, 136, 290.
- „ „ used in paint manufacture, &c., 313.
- „ „ „ soft soapmaking—*see* Soapmaking.
- „ drying of, chemical changes during, 129, 134-137.
- „ edible, 302-312.
- „ elaidin test—*see* Elaidin test.
- „ effect of heat on, 125-128, 314.
- „ „ light on, 130-132, 139, 149.
- „ „ polarised light — *see* Light (polarised).
- „ electrical conductivity of, 53.
- „ engine, 324.
- „ essential, artificial, 6.
- „ „ natural, 2, 5, 20, 53.
- „ ester numbers of—*see* Ester number.
- „ examination of, general scheme for, 124.
- „ expression of, 303—*see* Presses.
- „ extraction of, by solvents, 231-244, 303.
- „ „ fish and liver, by hot water, 248.
- „ „ vegetable, fats, &c., by hot water, 200.
- „ fish, 248, 259, 263, 294, 299.
- „ „ bleached by hot air, 264.
- „ „ „ bichromate, 265.
- „ „ colour reactions of, 294.
- „ „ detection in linseed oil, 352.
- „ „ give unpleasant smell to soft soap, 459.

- Oils, fish, used as adulterants, 348.
- „ „ used for soapmaking, 408
—see Soapmaking.
- „ fish liver, 247, 294, 408—see
also Oil (cod liver).
- „ fixed, 2.
- „ flashing points of—see Flashing
point.
- „ free acid, number of—see Acids
(free fatty).
- „ fusel, 6, 14, 20, 53.
- „ fusing points of—see Melting
points.
- „ general nature of, 1.
- „ glyceridic, 3, 93, 281.
- „ „ detected in sperm oil by
saponification, 354.
- „ gumming of—see Gumming.
- „ heat evolution with sulphuric
acid, 147-151, 341.
- „ „ with sulphuric acid,
effect of light on,
131, 139.
- „ Hehner's test for—see Hehner
number.
- „ herring, 294.
- „ Hübl's test—see Iodine number.
- „ hydrocarbon, 2, 5, 54, 90—see
also Oils (mineral, paraffin,
coaltar).
- „ hydrolysis of—see Hydrolysis.
- „ insoluble acid, number of—see
Insoluble acid number.
- „ iodine number of (iodine absorp-
tion of)—see Iodine number.
- „ kerosene, 2, 5.
- „ Koettstorfer's test—see Total
acid number.
- „ lamp—see Oils (burning).
- „ lesser known, 287-289.
- „ „ some probably
valuable, 289.
- „ liver, 294—see Oils (fish liver,
shark liver).
- „ „ colour reactions of, 294.
- „ „ contain cholesterol and
biliary constituents, 292.
- „ lubricating, 2, 5, 67, 321-330.
- „ „ absorption of oxygen
by, 134, 329, 330.
- „ „ analysis of, 328.
- „ „ characters and be-
haviour of, 325, 326.
- „ „ congelation of, 67, 325.
- „ „ flashing points of—
see Flashing point.
- „ „ free mineral acids in,
260, 322—see also
Lubricants.
- Oils, lubricating, manufacture of, 321-
328.
- „ „ metallic soaps con-
tained in, 121, 324.
- „ „ of fine quality from
dégiras, 337.
- „ „ specific gravity of, 325.
- „ „ spontaneous combus-
tion of, 133.
- „ „ viscosity of—see Vis-
cosity.
- „ „ volatility of, 325.
- „ machinery, 128, 324.
- „ medicinal, 303.
- „ malabar, 294.
- „ melting points of—see Melting
points.
- „ methyl iodide, test for—see
Methyl number.
- „ mineral (petroleum, natural
naphtha), 2, 5, 25.
- „ „ absorption of oxygen
by, 330.
- „ „ flashing point of, 126-128.
- „ „ lubricants containing,
322-330.
- „ „ refraction of, 52.
- „ „ relative price of, 342.
- „ „ specific gravity of, 90, 91.
- „ „ use of, in early ages for
burning, 312.
- „ „ viscosity of, 105.
- „ nitric acid on, action of—see
Nitric acid test.
- „ nitrous acid on, action of—see
Elaidin reaction.
- „ nondrying, 281.
- „ „ usually contain small
quantities of drying oils, 185,
282, 284, 344.
- „ nonglyceridic, 3, 93, 282.
- „ odour of—see Odour.
- „ order of price of, 342.
- „ oxidation of—see Absorption of
oxygen, Oils (blown), Oils
(drying), Gumming.
- „ oxidised—see Oxidised oils.
- „ paraffin, 2, 5, 91, 313.
- „ „ in soap, 258—see Soap,
special kinds of.
- „ petroleum—see Oils (mineral).
- „ phosphorised, from leguminous
plants, 123, 259.
- „ polarised light, action of, 50.
- „ porpoise, 293.
- „ proximate constituents of, 110-
124.
- „ purification (Noerdlinger's),
263.

- Oils, pyrene, 344.
- " rancidity in—*see* Rancid, Rancidity.
- " ray, 294.
- " red—*see* Red oils.
- " refining of, 254-263.
- " refractive index of—*see* Refractive index.
- " Reichert's test for—*see* Reichert number.
- " rosin—*see* Rosin oils.
- " salad, 212, 257, 303, 344.
- " " refined cotton seed oil intermixed with, 267.
- " saponaceous matters contained in, 121.
- " saponifiable, 3, 6, 323.
- " saponification number of—*see* Total acid number.
- " saponification equivalents of—*see* Saponification equivalents.
- " seal, 293.
- " " colour reactions of, 294.
- " semidrying, 286, 290.
- " " proportions between different glycerides in, 290, 291.
- " separation of stearines from—*see* Stearines.
- " shale, 2, 5, 90, 91, 313, 322.
- " shark liver, 247, 294, 408.
- " sod, 336.
- " solidifying points of—*see* Melting points.
- " soluble acid numbers of—*see* Soluble acid number.
- " solubility in solvents of—*see* Solubility.
- " specific gravity of, 76-94, 341.
- " " effect of light on, 130.
- " spindle, 128, 324.
- " spontaneous combustion of, 132.
- " " oxidation of—*see* Spontaneous oxidation.
- " standard, preparation of—*see* Standard.
- " sulphur chloride on, action of—*see* Sulphur chloride.
- " sulphocarbon, 344, 408.
- " sulphuric acid on, action of—*see* Sulphuric acid.
- " sulphurised, tests for, 123, 154.
- " summer, 257, 304, 348.
- " table—*see* Oils (edible, salad, virgin).
- " taste of—*see* Taste.
- " tournantes—*see* Huiles.
- " total acid numbers of—*see* Total acid number.
- Oils, train—*see* Oils (cetacean).
- " " class, 281, 292, 293.
- " " Turkey red, 27, 42.
- " " adulterations of, 334-336.
- " " analysis of, 332-336.
- " " bibliography of, 331.
- " " constitution of, 143-147, 330, 331.
- " " manufacture of, 330-332.
- " turret, 324.
- " uses of, 302.
- " unsaponifiable matters contained in—*see* Unsaponifiable matters.
- " vegetable, 281-285, 286-291, 295-298.
- " " lesser known, 287.
- " virgin, 304, 344—*see also* Oils (salad).
- " viscosity of—*see* Viscosity.
- " volatile, 2.
- " " acids from—*see* Volatile acids.
- " " number of—*see* Volatile acid number.
- " vulcanised, 154.
- " water contained in—*see* Water.
- " whale, 293—*see* Oils (cetacean).
- " " colour reactions of, 294.
- " winter, 230, 257, 348.
- " yield of, from seeds, &c.—*see* Yield.
- " " fatty acids from, 76, 163.
- " Zeisel's test for—*see* Methyl number.
- " zinc chloride on, action of—*see* Zinc chloride.
- Olberg, water bath, 61.
- Olefiant gas, 26.
- Olefines form glycols by oxidation, 44.
- Olein (oleic triglyceride), 7, 11, 28, 110, 285.
- " action of nitrous acid on—*see* Elaidin reaction.
- " " sulphuric acid on—*see* Oils (Turkey red).
- Oleine, candle—*see* Red oils.
- " cokernut, 90, 92, 231, 283.
- " palm kernel, 283.
- Oleines (commercial products), 90, 92, 110, 285.
- " animal, 285, 299.
- " distilled, 110, 262, 277, 285, 324, 377.
- " " hydrocarbons present in—*see* Hydrocarbons.

- Oleines, from wool grease, 276-279.
 ,, Turkey red oils, 285.
 ,, vegetable expressed, 110, 229, 257, 283.
 Oleine soaps—*see* Soapmaking.
 Oleomargarine—*see* Margarine.
 Oleometer, Lefebvre's, 79.
 Leonaphtha, 330.
 Oleorefractometer, 51-53, 347.
 Oleostearine, 93.
 Olive stearine, 230.
 Olive trees, different species and varieties of, 342.
 Opderbeck, oxygen process, 321.
 Open test (flashing point), 126.
 Oudemans, Rambutan tallow, 296.
 ,, stearic acid, 30.
 Overbeck, oxidation of stearolic acid, 36, 45.
 ,, oxyleic acid, 41.
 Ox tallow—*see* Tallow.
 Ox, utilisation of fat of an, 311.
 Oxalic acid from glycerol, 8, 519-522.
 ,, acids from glycols by fusion with potash, 18.
 Oxidation during boiling, 125.
 ,, of aldehydes, 20, 25.
 ,, of fatty acids during drying, 113.
 ,, of oils by light, 130-132, 139, 149.
 ,, of oils during drying, 42, 129-137—*see* Absorption of oxygen, Gumming.
 ,, products of fatty acids, 19, 33, 36, 40, 43.
 ,, ,, characteristic, 128, 129.
 ,, spontaneous—*see* Spontaneous oxidation.
 Oxidised oils (oils naturally containing oxygen), 3.
 ,, (commercial; really are sulphurised), 154.
 ,, (linseed "skins" for linoleum), 318.
 ,, (oils treated with oxidising materials), 42—*see also* Oils (blown, and refining of).
 Oxyacids formed during drying, 135.
 Oxygen, absorption of—*see* Absorption.
 ,, addition to "unsaturated" acids, 33, 36, 45.
 Oxyoleates, 42, 332.
 Oxyoleic acid, 41.
 ,, mixed glyceride, 144.
 Oxyolein, 139.
 Oxystearic mixed glyceride, 144.
 Ozokerite (solid mineral hydrocarbons, earthwax), 2, 5, 6, 88, 91, 364—*see also* Cerasin.
 ,, used as beeswax adulterant, 359.
- P**
- Paint, 135, 302.
 Palmer, metallic wick, 394.
 Palmieri, electrical conductivity, 53.
 Palmitin (palmitic triglyceride), 11, 285.
 ,, chief solid constituent of olive oil, 344.
 Palmitine (commercial product), 337, 407—*see also* Candle stearine.
 Pans for boiling oil, soap, &c.—*see* Kettles, Decomposing pan, Cooling pan, Re-melting pan, Crystallising pan, &c.
 ,, crutching soap, 438-442.
 Paracholesterol, 18.
 Paraffin wax—*see* Wax (paraffin).
 Paraphytosterol, 16, 17.
 Paring machine (oilcake), 223.
 Parings, edge runners for grinding, 220, 223.
 Paris Municipal Laboratory, 65, 82.
 Parnell, causticising under pressure, 413.
 Paterson, spectrum colorimeter, 50.
 Payne, glycerine manufacture, 515.
 ,, melting points of distilled fatty acids, 384.
 Pea nut—*see* Oil, arachis.
 Pearlash, 409.
 Pearlashing, 451, 479, 489.
 Peh-la—*see* Wax, Chinese.
 Pelargonium, 20.
 Pendulum machine, M'Naught's, 94.
 Pensky, flashing point apparatus, 127.
 Perfumes, injurious effects of excess of, in toilet soap, 480.
 ,, oils used in extraction of, 302, 479.
 ,, used for soap—*see* Soap-making (perfuming).
 Permanganate, oxidation by, characteristic products of, 128, 129.
 ,, ,, of acrylic acids, 28, 50, 41-44.
 ,, ,, of animal oils does not form stearic acid, 291.
 ,, ,, of linolenic acid, 37, 43, 128.

- Permanganate, oxidation of linolic acid 34, 35, 43, 128.
 „ „ of ricinoleic acid, 40, 43, 129.
 „ „ of stearolic acids, 33, 36, 45.
 „ „ rule respecting, 44.
 „ wax bleached by means of, 269.
- Peroxide of hydrogen as bleaching agent—*see* Hydrogen peroxide.
- Peters, linolic acid, 34.
 „ polarised light, 51.
- Petroleum—*see* Oil (mineral).
 „ ether (light petroleum spirit, benzoline), 2, 5.
 „ „ as solvent, 55, 115, 118-124, 231, 236, 252, 262, 273, 275, 328, 329, 336, 337—*see also* Soap analysis.
 „ „ fatty acids insoluble in, from boiled oil, 135.
 „ „ preferable to ordinary ether as solvent, 118, 120, 273, 275.
- Phasol, 16, 259.
- Pheasant grease, 298.
- Phenol (carbolic acid) and homologues, 3, 6, 15, 16, 53.
 „ determination of, in soap, 506.
 „ extraction from coaltar, 230.
 „ use of, in disinfectant soaps—*see* Soaps, special kinds of (carbolic, disinfectant).
- Phenolphthalein as indicator, 23, 115-117, 124, 328, 333, 359, 497.
- Phlorol, 16.
- Phosphorised constituents, 121.
- Phosphorus, determination of, 124.
- Physical properties of glycerol, 7.
 „ „ oils, &c., 47-109.
- Phytosterol, 6, 16, 17, 240, 259.
 „ „ determination of in oils, &c., 121.
- Pichurim bean fat, 20.
- Pickling soap bars, 438.
 „ wicks, 394, 395.
- Pigments (mottled soap), 472.
- Piston candlemoulding machines, 399.
- Pitch, Burgundy, adulterant of bees-wax, 359.
- Pitch formed in Wilson's process, 381.
 „ from distillation of foots by superheated steam, 261.
 „ „ of Yorkshire grease by superheated steam, 277.
- Pitch used as coarse lubricant, 277, 324.
- Pliny, early soapmaking processes, 449.
- Plotting (milled soap), 448.
- Plumbago (antifriction), 324.
- Pohl, melting points, 64.
- Poiseuille, viscosity, 107.
- Polariscope, polarised light—*see* Light, polarised.
- Polishing candles, 406.
 „ soap tablets, 448.
- Polyglycerols, 8.
- Polymerised fatty acids formed by elaidin reaction, 139.
 „ glycerides formed during boiling and drying, 135, 318.
 „ oleo-oxystearic acid, 330.
 „ ricinoleic acids—*see* Acid, ricinoleic.
- Pomades, lanolin used in making, 339.
 „ oils used in making, 302.
- Porpoise blubber, extraction of oil from, 247.
- Potassium carbonate, causticising—*see* Causticising.
 „ „ leys, alkalinity of, 419.
 „ „ used in Mège Mouries process, 308.
 „ „ used in pearlashing—*see* Pearlashing.
 „ „ used in soapmaking—*see* Soapmaking.
 „ chloride, action on soda soaps, 490, 491.
 „ „ source of potash, 410.
- Potash, action on brominated acids, 28.
 „ caustic (potassium hydroxide), effect of fusion with—*see* Hydrogen.
 „ from sunflower seeds, 305.
 „ leys, alkalinity of, 417, 419, 420.
 „ leys, preparation of, 411-414.
 „ neutralised—*see* Free acid number, Total acid number, &c.
 „ quantity equivalent to soda, 425.
 „ „ „ to fats—*see* Calculations.
 „ soaps, action of soda salts on, 451, 472, 473.

- Potash, use of, in refining oils, 256, 261.
 " vegetable alkali, 409.
 Potato fusel oils, 14.
 Poullain and Michaud, zinc oxide process, 379, 515.
 Poutet, elaidin reaction—*see* Elaidin.
 Power requisite in oil mill, 215-217.
 Precipitation processes (removing mucilage, &c.), 255, 262, 263.
 Press cake—*see* Cold press cake, Hot press cake, Separation cake.
 Presses, cold—*see* Cold press.
 " earlier forms of, 199.
 " elbow, 202.
 " hot—*see* Hot press.
 " hydraulic, 207, 343.
 " pressure requisite in, 211.
 " screw, 205, 343.
 " wedge, 203.
 Pressure, distillation under diminished—*see* Distillation.
 " in autoclaves, 373.
 " in oil presses, 211.
 " rendering tallow under increased, 250.
 " soapmaking under increased, 462-464.
 Prices of oils, &c., 342.
 Primrose soaps, 474, 509, 510.
 Printing ink, 125, 317, 318.
 Proximate constituents, 110-124.
 " " information wanted concerning, 113.
 " " separation of, 111-113.
 " " variation with soil, climate, &c., 111.
 Pumps, soap, 434.
 Pulfrich, refractometer, 51.
 Purvis, waggon grease, 327.
 Pyknometer, 77.
 Pyramid drainage surface (filter-press), 229.
 " night lights, 406.
- Q**
- QUANTITATIVE reactions of oils, &c., 156-198.
 " tests for oils, tabulated, 194-198.
 Quantity of alkali requisite for saponification—*see* Calculations.
 Quebrachol, 16.
 Quicklime—*see* Lime.
 Quinquet, use of lamp chimneys, 313.
- R**
- RADISSON, palmitic acid process, 387.
- Railway grease—*see* Lubricants.
 Rancid tallow, &c., cleansing of, 256, 260, 261, 265, 310.
 Rancidity, 10, 49, 69, 255.
 " due to oxidation, 132.
 " light promotes, 132.
 " produces much free fatty acid, 10, 114, 255, 355.
 Rape seed (colza, cole seed), various species of, 348.
 Raphigaster, 25.
 Rational Beaumé scale, 86.
 Raw oils, 313—*see* Oils (drying).
 Reaction, specific temperature, 149.
 Reactions of oils, &c., quantitative, 156-193.
 Reaumur scale, 57, 58.
 Recovered greases—*see* Grease.
 Red oils (crude oleic acid, candle oleine), 110, 231, 285.
 " analysis of, 375, 378.
 " expression of, 231, 370.
 " filter cake—*see* Filter cake.
 " palmitic acid from, 387.
 " soap from—*see* Soapmaking
 " unsaponified grease in—*see* Unsaponified fat.
 " utilisation of, 386-388.
 " yield from ox fat, 311, 312.
 Redwood, viscosimeter, 98.
 " " results obtained by, 101-105.
 Refining oils, &c., 254-263.
 " acid processes, 259, 349.
 " alkaline " 260, 349.
 " " process removes free acids, 12, 115, 260, 322.
 " by treatment with water, 344
 " Hartley and Blenkinsop's process, 263.
 " Noerdlinger's process, 263.
 " precipitation processes, 262.
 " virgin oils, 304.
 Reformatsky, linolic acid, 34, 35.
 Refractive index, refractometer, 51, 341.
 Reichert's test (Reichert number), 23, 53, 157, 195, 341.
 " mode of working, 173-176.
 Reichert-Meissl test, 174, 195.
 Reichert-Wollny " 175.
 Reichl, test for glycerol, 8, 516.
 Reimer and Will, diercucin, 11.
 " rapic acid, 41.
 Relative density—*see* Specific gravity.
 " viscosity—*see* Viscosity.
 Remelting pans, 441-443.
 Renard, test for arachis oil, 344.
 Rendering animal fats, 245-251.

- Resin (pine)**—*see* Rosin.
 „ used for early torches, 312.
Resinate of soda, 450, 453.
 „ calculations respecting, 455, 465.
 „ use of, in soapmaking—*see* Soapmaking;
 Soap, special kinds (yellow soap).
Resinous constituents of oils, 118.
 „ „ removal of, from oils, 255, 256, 260, 262, 322.
Resins and resinoid bodies, 3, 25.
 „ „ used as beeswax adulterants, 359.
Richards, testing liability to spontaneous inflammability, 133.
Richardson and Watts, railway grease, 327.
Richmond, density of glycerol solution, 517.
Ricinelaidin, 40, 137.
Ricinolein (ricinoleic triglyceride), 40.
 „ action of nitrous acid on, 137.
 „ distillation of, 40.
Rideal, viscosity of gum solutions, 108.
Ritser, causes of rancidity, 132.
 „ glycerine testing, 515.
Rock—*see* Candle stearine.
Rolls—*see* Crushing rolls.
Rose, Down and Thompson, oil press machinery, 215.
Rosin (colophony), 88, 92, 118, 178.
 „ action of sulphur chloride on, 156.
 „ admixed with thickened oils, &c., 142.
 „ adulteration of linseed oil with, 352.
 „ „ of beeswax with, 359.
 „ manufacture of resinate of soda, 453.
 „ use in making lubricating greases, 327-329.
 „ „ soapmaking—*see* Soapmaking.
 „ window glass, 474.
Rosin oils, 2, 92.
 „ „ absorption of oxygen by, 330.
 „ „ action of, on polarised light, 50.
 „ „ adulteration of linseed oil with, 352.
 „ „ detection of, in Turkey red oils, 335.
 „ „ fluorescence of, 50.
Rosin oils, refractive index of, 52.
 „ „ relative price of, 342.
 „ „ solubility in glacial acetic acid, 55, 57, 329.
 „ „ use of, in preparing lubricants, 322-324, 327-329.
 „ „ viscosity of, 105.
Rotation of polarised light—*see* Light (polarised).
Royan, candle moulding machine, 398.
Rüdorff, melting points, 69.
Rule followed in oxidation, 44.
Rush lights, rush pith wicks, 312, 362, 390.
Russian mineral oils (viscosity), 105.
Rutschmann, stripping machine, 446.
- S**
- SAKE**, grease recovery, 272.
Salad oils—*see* Oils (salad).
Salt as source of alkali (soda), 410.
 „ in butter, &c., 123, 307.
Salting out, 23, 33, 54.
 „ in refining oils, &c., 256.
 „ in soapboiling—*see* Soapmaking.
 „ in Turkey red oil making, 331.
Sand, use of, in clarifying oils, 255.
Sanza (olive marc), 343.
Saponaceous matters in oils, &c., 121-124, 135, 315, 324, 328, 347.
Saponification by alkaline carbonates, 409, 410.
Saponification equivalents, 33, 158, 194, 341.
 „ „ determination of, 161-170.
 „ „ of glycerides exceeded mean equivalents of acids by 12.67, 165.
 „ in three stages, 468.
 „ number—*see* Total acid number.
 „ quantity of ley requisite for—*see* Calculations.
Saponification, typical reactions of, 3-5.
Saponin, 297.
Sarg, utilisation of fat of an ox, 311.
Saturated hydrocarbons—*see* Hydrocarbons.
Saturation, fractional, 112, 113.
Saytzeff, dioxystearic acids, 28, 30, 41, 42, 46, 129.

- Saytzeff, oxystearic acids, 38, 39.
 ,, use of mercuric bromide in
 Hübl's test, 179.
- Scales, hydrometer, 84-86.
 ,, thermometer, 57-60.
- Schädler, amounts of fatty matter in
 seeds, &c, 241-244.
 ,, cohesion figures, 49.
 ,, colour reactions, 154, 294.
 ,, distillation with superheated
 steam, 383.
 ,, hydrometer scales, 85.
 ,, iodine numbers, 182.
 ,, melting points, 67-70.
 ,, nonexistence of doeglic acid,
 24.
 ,, polarised light, 50.
 ,, Reichert-Meißl numbers, 174
 ,, Royan's candle moulding
 machine, 398.
 ,, solubilities, 54, 55.
 ,, specific gravities, 87.
 ,, total acid numbers, 160.
 ,, unsaponifiable matters, 257.
 ,, yield of linseed oil, 351.
 ,, rape seed oils, 348.
- Schepperand Geitel, melting points.76
 ,, separation cake, 376.
- Scheme for examination of oils, 124.
 ,, soaps, 506.
- Scheurer Kestner, Turkey red oils,
 146, 333.
- Schlink, deodorising cokernut oil, 310.
- Schmid, viscosimeter, 95.
- Schmidt's process (zinc chloride and
 oleic acid), 142, 386.
- Schmitz and Tøenges, oxyoleates, 332.
- Schnaible, toluene as solvent for wax
 in soap, 496.
- Schön, hypogæic acid, 24.
- Schröder, oxyhypogæic acid, 41.
 ,, palmitoxylic acid, 45.
 ,, — see Grills and Schröder.
- Schübler, viscosimeter, 95.
 ,, results with, 102.
- Schüler, linoleic acid, 33.
- Scotch mineral oils, viscosity of, 105.
- Scourtins (oil extraction), 204.
- Scraps from ox fat, 311.
- Screens for sifting seeds, &c., 223.
- Screw presses, 205-207.
- Scribe for marking soap blocks, 437.
- Seal blubber, extraction of oil from, 247.
- Sealing wax, 502.
- Sea weed jelly (antifriction), 324, 328.
- Seed crushing—see Oil mill plant, and
 Crushing rolls.
- Seeding (of press cake)—see Separation
 cake.
- Seeds, determination of fat in, 237.
 ,, yield of fatty matter from, 241-
 244.
- Seibel, sulphurised lanolin, 339.
- Seltsam, bone fat extraction process,
 253, 254.
- Separation of fatty acids, 112, 113.
 ,, proximate constituents,
 111.
- Separation cake, (press cake), 311.
 ,, analysis of, 375, 378.
 ,, seeding (granula-
 tion, crystallisa-
 tion) of, 355, 367.
- Shale oils—see Oils (shale).
- Shark livers, extraction of oils from,
 247.
- Shaving cream, 483.
- Sbea butter—see Butters, vegetable
 (Shea).
- Sheep's tallow—see Tallow.
- Shoddy scourings, grease from, 276.
- Silver, bromostearate, action of water
 on, 25, 30.
 ,, hydroxide, action on bromin-
 ated acids, &c., 27, 30, 41, 43.
 ,, nitrate test, 152-154.
 ,, test (Becchi's)—see Becchi's test.
- Skalweit, density of glycerine solu-
 tion, 516, 517.
- Singer and Judell, wool scouring, 337.
- Skimmer pipe (soap kettle), 433, 434.
- Skins from drying oils, 135, 381.
 ,, tanning and currying, 302, 336.
 ,, tender, injurious effects of
 alkaline, highly perfumed,
 and sugared soaps on—see
 Soap, alkaline; Soap, special
 kinds of (transparent; highly
 scented).
- Slabbing soap, 437, 438, 444.
- Smith, Watson, wool scouring, 337.
- Soap, alkaline, calculations respecting
 excess of alkali in, 454, 464.
 ,, ,, degree of alkalinity judged
 by tongue, 510.
 ,, ,, injurious effects of, on ten-
 der skins, 458, 479.
 ,, ,, on wool, silk, &c.,
 453, 461.
- Soap analysis—
 Cailletet's method, 507, 508.
 Calcium salt test, 508.
 Classification of toilet soaps, 512.
 Determination of actual soap, 492,
 493.
 ,, ,, calcula-
 tion respecting, 493.
 ,, of alcohol, 505, 506.

Soap analysis—

- Determination of average molecular weight of fatty acids, 172, 494.
- ,, crude fatty acids, 492, 493, 496, 506.
- ,, fatty anhydrides, 493, 496, 497, 506.
- ,, free alkali, 492, 497-501, 507, 512.
- ,, ,, as caustic, 498-500, 507.
- ,, ,, as carbonate, 500, 507.
- ,, ,, by alcohol test, 498.
- ,, ,, by fatty acid titration test, 499.
- ,, ,, by salting out test, 500.
- ,, ,, by salting out test, excess found by, 500.
- ,, glycerol 494, 504-506, 512.
- ,, hydrocarbons (paraffin, &c.), 258, 495, 496, 506.
- ,, mineral weighting admixtures (China clay, steatite, &c.), 494, 504, 507.
- ,, organic weighting admixtures (starch, oatmeal, sawdust, &c.), 494, 504, 507.
- ,, phenol and phenoloids, 506.
- ,, pigments, 504.
- ,, potash, 501, 506.
- ,, rosin acids, 474, 497, 506, 508.
- ,, ,, by Gladding's process, 485, 501, 502, 511.
- ,, ,, ,, sources of error in, 502.
- ,, ,, by modified Gladding's process, 502.
- ,, ,, by Twitchell's process, 503, 504, 511.
- ,, salts (sulphates, chlorides, &c.), 494, 497, 499, 506, 507.
- ,, silicate, 494, 497, 504, 507.
- ,, soluble acids, 496, 497, 499.
- ,, sugar, 494, 504-506.
- ,, total alkali, 492, 493, 496, 497, 506.
- ,, unsaponifiable matters, 119, 258, 492-495, 497, 506.

Soap analysis—

- Determination of unsaponified fat, 492, 495-497, 506.
- ,, volatile matters, 505.
- ,, water, 494, 495, 506.
- ,, waxy matters (beeswax, spermaceti, cholesterol, &c.), 495, 496, 506.
- General schemes, 494, 506, 507.
- Typical results (manufacturers', pharmaceutical, toilet, soft soaps, &c.), 508, 511.
- Soap, bleaching dark coloured, 267.
- ,, chemistry of, 484-492.
- Soap factory plant, 426-448.
- Crutching pans, 438-441.
- Curbs, 432, 433.
- Cutting appliances, 437, 438.
- Fan, 433, 434, 460.
- Frames, 434-437, 444.
- Kettles (coppers, pans)—*see* Kettles.
- Milling machinery, 446.
- Plotting machinery, 448.
- Pumps, 434.
- Remelting pans, 441-443.
- Slabbing and barring machines, 437, 438.
- Stamping machines, 444, 445.
- Steam twirl, 428—*see also* Morfit.
- Stripping machine, 446.
- Soap, fused, reaction of salts, &c., on, 451, 473, 488-492.
- ,, ,, alkaline carbonates on, 451, 489, 490—*see also* Pearllashing.
- ,, historical references to, 449.
- ,, hydrolysis of, 486-488.
- ,, ,, Wright and Thompson's experiments, 487.
- ,, leaves, 483.
- ,, powders, 477.
- ,, saline matters in, calculations respecting, 455, 465.
- Soap, special kinds of—
- Aluminated, 451, 475.
- Bleached palm oil, 508.
- Borax, 451, 475.
- Castile, 467, 472, 508.
- Carbolic, 451, 477.
- Carbonated, 451, 462, 475, 477—*see also* Pearllashing.
- Cold water, 477, 509, 510.
- Curd—*see* Soapmaking.
- ,, amount of water present in, 470.
- ,, analysis of, 508, 510.
- Dealkalised (neutralised), 453, 461, 480, 481, 483, 484.

- Soap, special kinds of—
 Disinfectant (carbolic, cresylic, naphthol, sanitas, terebene, &c.), 451, 476, 477.
 Emollient (containing lanolin, spermaceti, vaseline, wax, &c.), 448, 478, 479.
 Fancy—*see infra* (Toilet).
 Filled—*see* Soapmaking (filling).
 Fitted—*see* Soapmaking (fitting).
 „ amount of water present in, 470.
 Floating, 441.
 Glycerine, 458.
 „ containing additional glycerol, 458, 479, 482, 512, 513.
 Harlequin, 483.
 Highly scented, injurious action of, 480, 512.
 Ivory, 509.
 Little pan, 479.
 Marbled, 483.
 Marine—*see* Soapmaking.
 „ analysis of, 508, 509.
 Marseilles, 467, 472, 508, 509.
 Medicinal (creosote, cresylic, ichthyol, iodine, mercurial, naphthol, sanitas, sulphur, terebene, &c.), 477.
 Metallic—*see* Metallic soaps.
 Milled, 446-448, 457, 479, 480, 511.
 Mottled—*see* Soapmaking.
 „ amount of water present in, 472.
 Neutralised—*see supra* (Dealkalised).
 Normandy, 475.
 Oil (red oil, oleine)—*see* Soapmaking.
 Old brown windsor, 480.
 „ „ modern inferior kinds of, 481.
 Oleine—*see* Soapmaking.
 „ analysis of, 509, 510.
 „ contains hydrocarbons, 258, 279, 496.
 Olive, 467, 472, 508.
 Paraffin and petroleum, 458, 476.
 Perfumers', 450, 456, 479.
 Pharmaceutical, 510.
 Phosphated, 476.
 Primrose—*see infra* Rosin soap.
 Remelted and blended toilet, 441, 478.
 Rosin (yellow), 450, 451, 453, 473, 474, 509.
 „ calculations respecting, 455, 465.
 „ French process, 473.
 „ primrose, 474, 509, 510.
- Soap, special kinds of—
 Kosin, primrose, analyses of, 509, 510.
 Sand (brickdust, emery, fullers' earth, kaolin, pipeclay, pumicestone, &c.), 476.
 Shaving cream, 483.
 Silicated, 451, 453, 462, 472, 474, 475.
 „ calculations respecting, 455, 465.
 „ objectionable for wool scouring and laundry purposes, 461, 475.
 „ wastes less rapidly, 475.
 Soft—*see* Soapmaking.
 Starch (oatmeal, bran, cornflour, dextrine, gluten, Iceland moss, sawdust, &c.), 477.
 Sugared—*see infra* Transparent.
 Sulphated, 451, 475.
 Superfatted, 478, 479.
 Toilet (fancy), 409, 441, 478-480.
 „ analyses of, 511.
 „ classification of, 512.
 Tooth, 476.
 Transparent, cold process, 450, 458, 476, 482.
 „ „ analysis of, 511.
 „ „ calculations respecting, 465.
 „ „ injurious effects on tender skins, 458, 459, 490, 482, 512.
 „ „ sugared, 458, 480, 482, 511, 512.
 „ „ transparency increased by alcohol, glycerol, sugar, 458, 481.
 „ „ spirit process, 445, 446, 458, 474, 482.
 „ „ analyses of, 511.
 „ „ distillation of spirit, 446, 482.
 White windsor, 481.
 Wool scouring, 458.
- Soap, water in, calculations, respecting, 454, 464.
 „ „ determination of—*see* Soap analysis (water).
 Soapmaking, classification of processes—direct neutralisation, 450-456.
 „ glycerides used and glycerol retained, 450, 456-466.
 „ glycerides used and glycerol eliminated, 451, 466-473.

Soapmaking, factory operations—
 Cleansing curd, 467.
 Crutching, 438-440, 441.
 Cutting, slabbing, and barring, 437, 438, 444, 449.
 Dealkalising—*see* Soap, special kinds of (dealkalised).
 Drying, 438, 447.
 Filling (loading), 438, 450, 458, 462, 465, 472, 476, 483, 511.
 Fitting, 451, 467, 470, 471.
 Framing, 434-437, 444, 449.
 Graining (cutting the soap; salting out), 54, 413, 433, 450, 469, 485.
 Killing—*see infra* Manufacture of curd.
 Loading—*see supra* Filling.
 Manufacture by cold process, 450, 457, 513
 „ „ calculations respecting, 464-466.
 „ by old German process, 449, 451, 472, 473.
 „ of curd soap, boiling for curd, 451, 467-470.
 „ „ analysis of curd soap, 508, 510.
 „ of fitted soaps—*see supra* Fitting.
 „ of hydrated soap, 450, 456, 461.
 „ „ (Swiss soap, Eschwege Seife), 461.
 „ „ under pressure, 450, 456, 461.
 „ of marine soap, 450, 456, 461, 508, 509.
 „ of milled soap—*see infra* Milling.
 „ of mottled soap, 451, 466, 471, 472, 509.
 „ „ modern inferior kinds, 467, 472.
 „ of olcine soap (oil soap), 258, 451-453.
 „ „ analyses of, 509, 510.
 „ „ calculations respecting, 454-456.
 „ of resinate of soda, 453.
 „ of soft soap, 450, 456, 459, 466.
 „ „ analyses of, 510.
 „ of transparent soap—*see* Soap, special kinds of (transparent).
 „ of yellow soap (rosin soap)—*see* Soap, special kinds of (rosin).

Soapmaking, factory operations—
 Milling, 446, 457, 479, 480.
 Pearllashing, 451, 479, 489.
 Perfuming (scenting), 441, 444, 448, 457, 478-480, 483, 512.
 Pickling bars, 438.
 Plotting, 448.
 Preparation of leys, 411-426—*see also* Alkali, Alkalinity, Causticising, Potash, Soda.
 „ calculation of quantity requisite for saponification, 421-426.
 Remelting, 441-443, 478.
 Running off spent leys, 428, 432, 433, 469.
 Salting out—*see supra* Graining.
 Slabbing and barring, 437, 444, 449.
 Stamping tablets, 444, 445, 449.
 Stripping, 446.
 Tinting, 441, 479.
Soapmaking, raw materials for, 302, 408-411.
Soaps, colonial, 509.
 „ commercial (manufacturer's, laundry, &c.), composition of, by analysis, 508-510.
 „ discoloration of, 266, 356, 479.
 „ discoloured, bleaching of, 267.
 „ ingredients in lubricating mixtures, 324-329.
 „ jellifying of, 485.
 „ manufacturers—*see* Soaps, commercial.
 „ metallic—*see* Metallic soaps.
 „ mixed, formed from mixture of acids and excess of alkali, 491.
 „ salting out from solution (Whitelaw)—*see* Soapmaking (graining), 486.
 „ solubility in water, &c., 485.
 „ toilet, classification of, according to free alkali, 512.
 „ „ composition of, by analysis, 511.
Soapsuds, recovery of grease from—
see Grease.
Soap test, Clark's (water hardness), 485, 508.
Soda ash, 410.
 „ „ causticising—*see* Causticising.
 „ caustic (sodium hydroxide), 410.
 „ „ colour test, 151, 153, 352.
 „ „ effect of fusion with (soda lime)—*see* Hydrogen.
 „ „ leys, alkalinity of, 414-416, 419, 420.

- Soda, caustic leys, employment in soap boiling—*see* Soapmaking.
- “ “ “ preparation of, 411-414.
- “ “ “ quantity equivalent to fats—*see* Calculations.
- “ “ “ storage of, 412.
- “ “ “ variation of density of, with temperature, 416.
- “ “ manufacture of, 410.
- “ “ use in making waggon grease, 327.
- “ “ “ refining oils, 260, 261.
- “ crystals, fused, use in oil refining, 260.
- “ degrees—*see* Degrees.
- “ quantity equivalent to potash, 425.
- “ trade, British custom as to alkalinity, 420.
- Sodium carbonate, action on potash soaps, 488-490.
- “ as lard adulterant, 306.
- “ direct use in soapmaking, 409, 433, 453, 463.
- “ leys, alkalinity of, 418—*see also* Caustic soda.
- “ use in making waggon grease, 327.
- “ use in refining oils, 256, 261.
- Sodium chloride, action on potash soaps, 451, 473, 490.
- “ silicate, manufacture of, 463.
- “ sulphate, Leblanc process, 410.
- “ “ used in refining oils, 256.
- Soft soap—*see* Soapmaking.
- Softening point, 61.
- Solar stearine—*see* Stearine (lard).
- Solutions for chilling baths, 67.
- Solid adulterants of fats, &c., 123.
- Solidification points—*see* Melting points.
- Soluble acid number, 168, 195.
- Solubility of blown oils, 320.
- “ of fatty acids in alcohol, 23.
- “ “ in water, 23.
- “ of lead salts in ether—*see* Ether.
- “ of oils, &c., in alcohol, 54.
- “ “ in glacial acetic acid, 55-57, 329, 347, 349.
- “ “ in water, 53, 54.
- Solubility of oils in various solvents, 55, 341.
- “ of wax in various solvents, 359.
- Solvents, extraction of oils by means of, 114, 231-244, 303.
- “ for oils, &c.—*see* Solubility.
- “ oils used as, for odorous matters, 302.
- “ treatment of wool with, 337.
- Souchère, adulteration of olive oil, 345.
- Soxhlet's tube, 119, 238.
- “ modifications of, 239.
- Specific gravity of alkaline leys, 415-419.
- “ caustic soda, effect of temperature on, 416.
- “ lubricating oils, 325.
- “ oils, &c., 76-94, 341.
- “ “ effect of light on, 130.
- “ “ temperature on, 79, 92-94.
- Specific temperature reaction, 149.
- Spectroscope, absorption, 50.
- Spermaceti, 4, 14, 21, 292, 302, 353, 359-361.
- “ added to soaps, 448.
- “ adulterations of, 360.
- “ candles—*see* Candles (sperm).
- “ chiefly obtained from oils of toothed whales, 293, 300, 301.
- “ class, 282, 301.
- “ foets, 261, 360.
- “ free cetylic alcohol in, 116, 171, 361.
- “ iodine absorption of, 182.
- “ refining, 261, 360.
- “ saponification equivalent of, 161.
- “ various physical properties of, 68-70, 88, 91-93, 360.
- Spills, manufacture of, 407.
- Spirit oil (Yorkshire grease distillation), 277, 278.
- Spirit soap (transparent)—*see* Soapmaking; Soap (special kinds).
- Spontaneous combustion, 132.
- “ oxidation, 42, 113, 129, 137, 323.
- “ “ more rapid under influence of light, 130-132.
- Square soap kettles, 433.
- Squirting soap, 448.
- Stamping machines, 444, 445.
- Standard candles (sperm), 402.
- “ oils, preparation of, 213, 340.
- “ water as, specific temperature reaction, 149.
- Standards of comparison, oils and mixtures, &c., 340, 346.
- “ efflux viscosity, 101.
- “ specific gravity, 78, 89.

- Stannic chloride, colour test, 151.
 Starch as adulterant of beeswax, 359.
 " " fats, 123, 307, 355.
 Starch in soft soap, 459.
 Steam, distillation with—*see* Distillation.
 " dry, 428-433, 459.
 " kettles heated by, 428, 432, 433, 441, 452, 459.
 " twirl (Morfit's)—*see* Morfit.
 " wet, 428-433, 459.
 Stearic aldehyde, 14.
 Stearin (stearic triglyceride), 4, 11, 110, 285.
 Stearine, beef, 307, 309.
 " candle—*see* Candle stearine.
 " candles—*see* Candles.
 " cokernut, 91, 92, 231, 283, 305, 363.
 " " use for nightlights, candles, &c., 363, 364, 407.
 " cotton seed, 91, 184, 230, 295, 304, 305, 307, 354.
 " " socalled, from distillation of foots, 262, 305.
 " French, 365.
 " lard (solar stearine), 93, 231, 307.
 " olive, 230.
 " tallow (pressed tallow), 231, 331, 407.
 " yield from ox fat, 311, 312.
 Stearines (commercial products), 88, 91-93, 230, 285.
 " distilled, 110, 262, 277, 305, 324.
 " " adulteration of tallow with, 355.
 " " from cotton seed foots, 262, 305.
 " " from Yorkshire grease, 277, 355.
 " " uscin soapmaking, 450.
 " expressed from natural oils, &c., 110, 229, 257, 305, 309, 407.
 " " used as lard adulterants, 307.
 " " " as tallow adulterants, 354.
 " from animal oils and fats, 230, 231, 307, 311.
 Stearolactone, 30, 39, 143, 262, 273, 384.
 " correction for presence of, 170, 273.
 Stearyl cyanide, 21.
 Steatite added to soft soap, 459.
 " (antifriction), 324.
 Stein, Bergé, and de Roubaix, sulphurous acid process, 380.
 Stereochemical isomerism, 29.
 Stills—*see* Distillation.
 Stoddart, nitric acid test, 140.
 Storax, 16, 19.
 Stripping (soap), 446.
 Strohmer, deusity of glycerol solution, 517.
 " refractive index, 51.
 Stürcke, Carnauba wax derivatives, 18, 37.
 Substitution derivatives, bromo, 26-28, 30, 31, 34, 38, 41, 42, 45, 176.
 " " chloro, 177.
 " " chloro, 30-32, 267, 364
 " " iodo, 26, 27, 30, 31, 38, 177—*see also* Iodine number.
 Sudcake, 272.
 Suds, grease recovered from—*see* Grease.
 Sugar in toilet soaps—*see* Soap, special kinds (transparent).
 " test for sesamé oil, &c., 153, 346, 352.
 Suet, 55, 70, 91, 161, 164, 181, 298.
 Suint, 337.
 Sulphur, adulterant of beeswax, 359.
 " candles, 407.
 " chloride reaction, 154-156, 341.
 " dioxide (liquefied) as solvent, 236.
 " " use in candle stearine making, 369, 370.
 " trioxide, use of, in bleaching oils, 264.
 Sulphuric acid, action on glycerol, 144.
 " " isoleic acid, 38.
 " " oleic acid, 27, 29.
 " " olein and ricinolein—*see* Oils (Turkey red).
 " colour reactions with oils, 151-153, 294, 341, 352, 354.
 " decomposing rock by, 366.
 " heat evolved by—*see* Oils (heat evolution).
 " preparation of, of constant strength, 148.
 " presence of, in oils, &c., 123.
 " reaction with cholesterol and allied bodies, 17.
 " refining with, 123, 255, 259.
 " removal of lime salts from bonefat by, 256.

- Sulphuric acid, saponification by, 143, 145, 380-382.
 ,, test for hydrocarbons in beeswax, 359.
 ,, use of, in finishing hot press cake, 368.
 ,, ,, in rendering tallow, 249.
 ,, ,, in Yorkshire grease process, 271.
- Sulphurised constituents of oils, 123, 154.
- Sulphurous acid as bleaching agent, 264.
 ,, ,, saponifying agent, 390.
- Sumbul root, 25.
- Summer oils—*see* Oils, summer.
 ,, railway grease, 327.
- Superheated steam—*see* Distillation (with superheated steam).
- Suspended matters, action of, in removing mucilage, 255.
 ,, in solid fats, &c., 123, 341.
 ,, removal of, from oils, &c., 228, 254-256.
- Sustainer for night lights, 406.
- Sweet water (crude glycerol solution)—*see* Glycerine manufacture.
- Sycocerylic alcohol, 16.
- Synthesis of glycerides, 11.
- T**
- TABLES of errors, hydrometer, 82, 83.
 ,, hydrostatic balance, 83, 84.
- Tablets (soap), cutting and stamping, 444.
- Tallow (ox tallow, mutton tallow; ox, sheep, &c., fat; beef fat), 3, 21, 55, 56, 293, 299, 303, 311, 322, 354.
 ,, adulteration of, 123, 258, 354-356, 370.
 ,, bleaching of, 264-266.
 ,, candles—*see* Candles (tallow).
 ,, different varieties of, 354.
 ,, engine, 324.
 ,, flashing point, 128.
 ,, free fatty acids present in, 355, 356.
 ,, iodine number, 181-184, 356.
 ,, ,, useful as test of quality, 356.
 ,, melting point, 68, 69, 355.
 ,, ,, of fatty acids from, 69-71, 74-76.
 ,, neutralisation number of fatty acids from, 164.
- Tallow oil—*see* Oil (tallow).
 ,, rancid, cleansing of—*see* Rancid.
 ,, Reichert number, 175.
 ,, relative viscosity, 102-105.
 ,, rendering, 246-251.
 ,, saponification equivalent and total acid number, 159, 161, 355.
 ,, specific gravity, 83-93, 355.
 ,, stearine—*see* Stearine (tallow).
 ,, unsaponifiable matters present in, 257.
 ,, use of, in lubricating mixtures, &c., 322-328, 356.
 ,, ,, in soapmaking, 356, 408—*see* Soapmaking.
 ,, valuation of, by Dalican's method, 74, 355.
 ,, ,, de Schepper and Geitel's tables, 76.
- Tallows, vegetable—*see* Butters, vegetable.
- Tannery grease, 299.
- Tannin, use of, in refining, 256, 263.
- Tapers, 389.
- Tar as lubricant—*see* Lubricants.
- Tariri, 36.
- Taste of oils, &c., 49, 341.
 ,, improved by presence of free acid, 116.
- Teal, oil bleaching, 264.
- Temperature of complete fusion, 61.
 ,, of incipient fusion, 62.
 ,, of turbidity (Valenta's test), 55-57.
 ,, reaction, specific, 149.
 ,, variation of specific gravity with, 92-94, 416.
 ,, ,, viscosity with, 102-106.
- Tempering metals in oil baths, 302.
- Testing machines, viscosity, 94.
- Tetrabromides, 31, 34, 36, 176.
- Tetracetyl derivative, 35.
- Tetrachloride of carbon—*see* Carbon.
- Tetraiodides, 31.
- Textile fabrics, oil used in preparation of, 270, 272, 279, 302.
- Texture, physical, of oils, &c., 47, 341.
- Thenard process (oil refining), 259.
- Thermal ærometer, Langlet's, 82, 347.
- Thermeleometer, Jean's, 151.
- Thermohydrometer, Fletcher's, 80.
- Thermometric scales, 57.
- Thiocyanic ethers, 15, 123.
- Thomson and Ballantyne, blown oils, 320.
 ,, ,, iodine numbers, 180.

Thomson and Ballantyne, iodine numbers of linseed oil, 180, 351.
 " " specific temperature reaction, 149, 349.
 " " unsaponifiable matters, 259.
 " " Valenta's test, 57.
 Thousandfold scale of specific gravity, 83, 84.
 Thum, fractional saturation, 13.
 " free acids formed by hydrolysis, 12.
 Thymol,
 Tilghmann, hydrolysis under pressure, 385.
 " soapmaking under pressure, 463.
 Time of efflux—*see* Viscosity.
 Titration, 23, 116, 161, 168, 173, 323, 328, 352, 359, 420—*see also* Soap analysis.
 " acetyl number, 198.
 " of alkaline leys preferable to density valuation, 420.
 " test, fatty acid—*see* Soap analysis (determination of free alkali).
 Toluene (solvent for wax in soap), 496.
 Tomlinson, cohesion figures, 345.
 Torches, 312, 362.
 Total acid number (saponification number, Kœttstorfer number), 33, 157, 168, 194, 341.
 Transparent soap—*see* Soapmaking, Soap (special kinds), Colloidal state of soap.
 Traube, friction in tubes, 109.
 Triacetin, 8, 186.
 Triglycerides, 9.
 " synthesis of, 11.
 Triglycerol, 8.
 Tünnermann, specific gravity of alkaline leys, 415, 417.
 Turkey fat, 298.
 " red oils—*see* Oils (Turkey red).
 Turpentine—*see* Oil (turpentine).
 Turpentine, crude (Meinecke's rosin soap), 473.
 Turtle fat, 299.
 Twaddell, hydrometer scale, 84, 86.
 Twitchell, rosin in soap, 503, 504.

U

UNIT mill (Anglo-American system), 217.
 Unsaponifiable matters contained in oils, &c., 116, 257, 258, 341, 355.

Unsaponifiable matters in candle stearine products, 371-374.
 " in Yorkshire grease, 273-279.
 " determination of, 119-124.
 " proportions usually present in oils, 257, 258.
 " in soaps, 258.
 Unsaponified fat, amount less with longer time, 373.
 " in red oils, 370, 377-379.
 " in rock, 371-374.
 " in separation cakes and press cakes, 376-379.
 " in soap, 119, 371.
 " interferes with crystallisation, 370.
 Unsaturated compounds, acids, 24.
 " alcohols, 15.
 " hydrocarbons, 3, 24, 26.
 " oxidation of, 44.
 Unguents in toilet soaps, 448.
 " lanolin preparations as, 338.
 " oils used for, 302.
 Ure, soft soap analyses, 510.
 Urine, damaluric acid from, 25.
 Utilisation of fat of an ox, 311.
 " red oils—*see* Red oils.

V

VALENTA'S test—*see* Acid (acetic).
 Valerin (valeric triglyceride), 20, 301.
 Vapour bath, Ambühl's, 80.
 Varnish making, 302.
 Variation of constituents of oils with soil, climate, &c., 111.
 " density with temperature—*see* Expansion.
 Vaseline, 91.
 " in soaps, 448.
 Vegetable alkali, 410.
 " fats, butters, and tallows—*see* Butters (vegetable).
 " lard—*see* Lard.
 Versmann, glycerine manufacture, 515.
 Villavecchia and Fabris, test for sesamé oil, 346.
 " " viscosity, 106.
 Vincent, boiling oils, 317.
 Viscidity of oils increased by blowing, 164—*see* Oils (blown).
 Viscosimetry, 94-109.
 Viscosity (body), 47, 94, 101.
 " degree, 102.

Viscosity, determination in absolute measure, 107.
 „ effect of light on, 131.
 „ efflux, 48, 94-106, 324-326, 341.
 „ of oils increased by addition of caoutchouc, 323.
 „ „ by blowing, 320.
 „ „ by metallic soaps, 121, 324.
 „ standards of, 101.
 Voelcker, amount of oil in linseed cake, 213.
 Volatile acid number, 176, 195, 341.
 „ acids, 22, 113.
 „ „ determination of—*see* Reichert test.
 Volatility of lubricating oils, 325.
 Vulcanising, 154, 318.

W

WAGGON grease—*see* Lubricants.
 Wagner, refining with zinc chloride, 260.
 „ rule concerning oxidation, 44.
 Wakefield fat—*see* Yorkshire grease.
 Walton, linoleum manufacture, 318.
 Wanklyn, aldehydic acid, 24.
 „ and Fox, glycerine valuation, 519.
 Warren, sulphur chloride and oils, 155.
 Washballs (soap), 448.
 Waste cleansing—*see* Engine waste.
 Water, action of, on silver bromo-stearate, 25, 30.
 „ agitation with, as purifying agent, 261.
 „ as standard for efflux velocity, 101.
 „ „ for specific temperature reaction, 149, 150.
 „ contained in beeswax, 359.
 „ „ oils, 122-124, 341.
 „ hot, extraction of vegetable oils, &c., by means of, 200-202.
 „ „ rendering animal fats, &c., with, 247.
 „ solubility in—*see* Solubility.
 Water bath for melting points, 60-64.
 „ „ specific gravity, 80.
 „ „ viscosimetry, 95-101.
 Watt, bichromate bleaching process, 265.
 „ chloride of soda bleaching process for soaps, 267.
 Watts—*see* Richardson and Watts.
 Wax candles—*see* Candles.

Waxes, animal and vegetable—
 Abyssinian, African, Andaquia, Antilles, 302.
 Beeswax, 4, 14, 21, 357-359.
 „ addition of fatty matter or oil of turpentine facilitates air bleaching, 268, 269, 358.
 „ adulterations of, 359.
 „ air bleaching, 264, 268, 357, 358.
 „ „ produces little change in density, 358.
 „ bibliography of, 359.
 „ bleached by chlorine apt to contain chloro substitution products, 267, 364, 390.
 „ bleaching by chemical processes, 264-267, 357.
 „ „ increases total acid number, and renders more crystalline, 266, 269, 364
 „ bromine absorption, 178.
 „ class, 282, 301, 302.
 „ ester number, 358.
 „ free acid number, 358.
 „ fusing point, 68, 69, 358.
 „ iodine number, 269, 358.
 „ iodine number diminished by chemical bleaching, 269.
 „ preparation of 201, 357.
 „ saponification equivalent and total acid number, 160, 269.
 „ solubility in solvents, 357.
 „ specific gravity, 88, 91-93, 358.
 „ virgin, 357.
 Carnauba wax, 14, 21, 301.
 „ an oxyacetic acid from, 37.
 „ bromine absorption, 178.
 „ class, 282, 301.
 „ glycol from, 5, 18.
 „ saponification equivalent, 160.
 „ specific gravity, 91.
 „ used as beeswax adulterant, 359.
 Chinese wax (Peh-la), 14, 21, 91, 302.
 „ extraction by hot water process, 201.
 Cordillera wax, 301.
 Cowtree wax, 301.
 Ficus wax, (fig wax, Getah wax), 14, 301.
 Indian wax (Arjun wax), 302.
 Japanese wax, 5, 21, 295.
 „ bromine absorption, 178.

- Waxes, animal and vegetable—**
Japanese wax contains practically no olein, 295.
 „ fusing point, 68-71.
 „ iodine number, 181-184.
 „ purification and bleaching, 268.
 „ saponification equivalent and total acid number, 160.
 „ solubility in alcohol, 55.
 „ specific gravity, 88, 91-93.
 „ unsaponifiable matter contained in, 257.
 „ yield of, 242.
Myrtle wax, 71, 91, 178, 295.
Niin wax (nin fat), 302.
Ocuba wax, 243, 295.
Otaba wax, 295.
Palm wax, 301.
Paraffin wax, 2, 5, 21, 91-93.
 „ adulterant of beeswax and spermaceti, 359, 361.
 „ as candle material—*see* Candles.
 „ manufacture of, 230, 364.
Pe-la (Peh-la, Pe-lah) wax—*see supra*, Chinese wax.
Petha wax, 301.
Spermaceti wax—*see* Spermaceti.
Ucuba wax, 295.
- Waxes, free alcohols in**, 114, 116.
 „ general nature of, 1.
 „ glyceridic and non-glyceridic, 3-5, 282, 301, 302.
 „ liquid, 6.
 — „ mineral (earthwax)—*see* Ozokerite.
 „ mostly indigestible, 303.
 „ used as spermaceti adulterants, 361.
 „ vegetable, hot water process of preparation, 201.
- Waxy matters, separation from oils**, 119.
- Wedge presses**, 199, 203.
 „ Chinese, 200.
- Wenzell, expansion**, 93.
Werner, oxyoleates, 332.
Westphal, hydrostatic balance, 79, 80.
Wet steam—*see* Steam.
- Whale blubber, extraction of oil from**, 247.
- Whales, toothed, yield most spermaceti**, 293, 300, 301.
- Whitelaw, salting out soap**, 486.
Whitelead in paint, 135.
Whiting, adulterant of tallow, 355.
- Wicks**, 312, 362, 363, 394.
 „ charring of, 116, 260, 313.
 „ Palmer's metallic, 394.
 „ pickling, 394.
- Wilde, de, and Reichler, conversion of oleic into stearic acid**, 387.
- Wilson, acetyl number**, 188, 335.
 „ analysis of Turkey red oils, 333-335.
 „ soap analysis, 495, 499.
 „ viscosity, 102.
 „ water in soap, 495.
- Wilson and Payne, hydrolysis by superheated water**, 385.
- Wilson's process** (preparing candle material), 262, 380, 334.
 „ „ (tallow rendering), 250.
- Wimmell, melting points**, 68.
- Winter oils**—*see* Oils (winter).
 „ railway grease, 327.
- Wire** (soap cutting), 437.
- Wollny, Reichert number**, 53, 175.
- Wool cleansing, wool scouring**, 271, 337, 338.
 „ „ injurious effect of alkaline and silicated soaps—*see* Soap, alkaline; Soap (special kinds), silicated.
- Woolfat, analysis of**, 276.
- Woolgrease**, 3, 70, 161, 182, 184, 299, 302, 337, 461—*see* Yorkshire grease; Lanolin.
 „ effect on soap, 258.
 „ tallow adulterated with, 258, 354, 369.
- Wool oil** (from Yorkshire grease distillation), 279.
- Wright, Alder** (author), analyses of manufacturers' and toilet soaps, 508-512.
 „ analysis of rock, stearine cakes, red oils, &c., 371-375.
 „ analysis of soap (free alkali), 500.
 „ autoclave experiments, 373.
 „ Cantor lectures, 487, 512, 523.
 „ classification of soaps according to alkalinity, 512.
 „ dealkalising process, 453, 461, 484.
 „ glycerine valuation, 523.
 „ hydrolysis of soap solutions, 487.
 „ methoxyl test, 192.

- Wright, Alder, use of iodine number in tallow valuation, 356, 375.
 Wright (Alder) and Muirhead, zinc chloride and oils, 141.
 Wright (Alder) and Thompson, chemistry of soap, 490-492.
 „ „ Gladding's process, 502.
 „ „ hydrolysis of soap, 487.
 „ „ systematic soap analysis, 494.
- X**
- XYLENOL**, 16.
- Y**
- YELLOW** ochre, beeswax adulterant, 359.
 Yield of fatty acids from oils, &c., 74, 163.
 „ fatty matter from seeds, nuts, beans, &c., 241-244, 348, 351.
 „ glycerol from oils, &c., 75, 162.
 „ solid stearine, 368.
Yorkshire grease, 110, 271-279, 324.
 „ adulteration of tallow with, 258, 354.
 „ amount of unsaponifiable matters increases with the density, 277.
- Yorkshire** grease, analysis of, 273.
 „ distillation of, 277, 383.
 „ hydrocarbons in distilled, 262.
 „ injurious effect on soap, 258.
- Z**
- ZEISEL'S** test—see Methyl number.
Zinc and hydrochloric acid, as dechlorinising agents, 35, 36.
 „ chloride, action on oils, 141, 142, 153.
 „ „ action on oleic acid, 39, 142, 262, 336.
 „ „ colour test, 153, 341.
 „ „ refining by means of, 255, 260.
 „ dust, as dechlorinising agent, 27, 31.
 „ isoleate, 30.
 „ oxide (antifriction), 328.
 „ „ as saponifying agent, 379, 410, 515.
 „ salts, separation of rapic and erucic acids by, 41.
 „ „ used in refining, 262, 263.
 „ sulphate (boiled oils), 262.
 „ soap, added to oils, &c., 121.
 „ white, in paint, 135.
Zürer, conversion of oleic into stearic acid, 386.

