

*The*  
*Gas and Water Engineer's Book of Reference.*

## E R R A T A .

PAGE.		<i>read</i>	
26	<i>For</i> price per 100 feet.		price per 1,000, and take figures under column <i>s.</i> as representing "per cent. of Cannel used"
68	" 2 (under guide columns) . . . . "		3
68	" 30 X 10 (8,600) . . . . "		30 X 12 (8,600)
68	" 60 X 20 (65,550) . . . . "		60 X 20 (56,550)
80	" 2 guide columns . . . . "		3 guide columns
81	" 2 guide columns . . . . "		3 guide columns
102	" poles (third line from bottom) . . . . "		piles

## P R E F A C E.

*It is now fourteen years since the First Edition of my GAS ENGINEER'S BOOK OF REFERENCE was published, and it has been out of print for some time past.*

*The present Edition has been almost entirely re-written, and it may be considered a practical treatise on Gas Engineering, even though it be almost wholly confined to a description of what I have designed and manufactured myself; but as my practice has now extended over a period of Thirty years, during which I have erected works in all quarters of the world for the manufacture of gas from almost every solid and liquid capable of yielding illuminating gas, I conceive that it is rather an advantage than otherwise to confine myself to what I know to be thoroughly effective.*

*I had intended to devote part of the book to Sanitary and Water-Work Engineering; but beyond including a section on Heating by Hot Water Circulation, I have not been able to do so. I hope, however, at some future time to treat on these subjects.*

*I have published a COMPANION to the BOOK OF REFERENCE separately, which gives prices in detail, so that anyone can ascertain the cost of a Manufacturing Plant up to the requirements of a considerable sized town, and anything beyond that can be tendered for specially, on sending the information required under Section T of the BOOK OF REFERENCE. I may say, that I have patterns and arrangements by which I can supply a Miniature apparatus for experimental purposes, and from that, by gradations up to Works I have actually erected, to produce a million cubic feet per day.*

*Independently of these patterns I have a vast collection of others, and of arrangements of apparatus not usually found with Gas Engineers and Contractors.*

*George Bower.*

ST. NEOTS, HUNTS,

1st January, 1880.

GEORGE BOWER,

*St. Neots, Hunts,*

MAY BE CONSULTED ON ALL MATTERS RELATING TO GAS-LIGHTING, *BY APPOINTMENT.*

PLANS, SPECIFICATIONS, AND ESTIMATES

FOR GAS-WORKS OF ANY MAGNITUDE.

OLD GAS-WORKS REMODELLED, LEASED, OR PURCHASED.

NEW GAS-WORKS ESTABLISHED,

AND (IN AN APPROVED LOCALITY) A PORTION OF THE CAPITAL PROVIDED IF REQUIRED.

PLANS AND SPECIFICATIONS

FURNISHED FOR THE NECESSARY BUILDINGS AND TANKS; ALSO

FULL INSTRUCTIONS FOR THE FIXING OF APPARATUS,

AND THEIR MANAGEMENT AFTER COMPLETION.

Attention is respectfully requested to the important improvements in GAS APPARATUS described in detail in the following pages, some of which may be briefly recapitulated as follows:—

The VERTICAL RETORT APPARATUS, especially adapted for small private works, its chief features being the ease with which it is manipulated, and the rapidity with which it produces Gas.

The DOUBLE-ACTING RETORT APPARATUS, expressly designed for the production of Gas from oil, resin, peat, wood, etc., as well as coal.

The AIR-LIGHT APPARATUS.

The COMBINED CONDENSING and PURIFYING APPARATUS; compact, effective, and easily managed.

EXHAUSTERS in duplicate, with Engines and Boilers.

The THROUGH-WAY, or STOP-VALVES, BY-PASS, and RISING PLUG CENTRAL CHANGE VALVES.

The CLOSED-TOP STATION GOVERNOR.

HIGH PRESSURE and CONSUMERS' GAS REGULATORS, constructed on the Equilibrium principle.

APPARATUS for LIGHTING RAILWAY CARRIAGES with GAS.

LAMP COLUMN, arranged to contain a Meter in the base.

LANTERNS with cast iron frames; the top and bottom parts being connected by two or three wrought iron rods, so as to offer as little obstruction to the light as possible.

*GEORGE BOWER, ST. NEOTS, HUNTINGDONSHIRE.*

## THE HISTORY OF GAS-LIGHTING.

ALTHOUGH the ancients were far advanced in the science of architecture and in many of the arts, in some of which they excelled the moderns, the existence of gases was unknown to them. This statement is confirmed by reference to Scripture, where we meet with the words, "Smoke goeth out of his nostrils as out of a seething pot or caldron;" also, "There went up a smoke out of his nostrils;"—from which we may conclude that steam and smoke were regarded as identical in their natures, although, probably, a distinction was made when describing the smoke arising from bodies in a state of combustion, and the vapours of fluids.

Burning fountains have been known to exist from remote ages, and, being attributed to supernatural agency, they were worshipped as emblems of the Deity. But it is now well known that these arose from coal, and other bituminous substances, being buried by earthquake or other means, at such a depth as to be distilled by the heat existing in the interior of our globe; thus the inflammable gases were expelled through the fissures of the earth, and on being ignited accidentally, or by lightning, the burning fountains were produced.

The art of Gas Lighting is so intimately associated with Chemistry, that the history of the former can only be given by reference to that of the latter. According to the comprehensive and exhaustive history of chemistry written by Boerhaave, about the middle of the eighteenth century, that science derived its name from the Greek "chemie," signifying a knowledge of the works of nature, and, in a second sense, the secret or dark art; but afterwards, when the Arabians principally cultivated the science, the word was altered by them to "alchemie," or alkemie."

The author referred to, states that the art is of great antiquity, and suggests that it originated with "Tubal Cain, an instructor of every artificer in brass and iron"; that all the earliest alchemists confined their observations to the study of metals, so far as relates to metallurgy, and subsequently the transmutation of the baser metals into gold and silver—was during many ages not only considered practicable, but was actually believed to have been frequently accomplished. This, however, we now understand, could only have been the result of trickery and fraud. We are also informed that, about the seventh century, attention began to be directed by some writers to the discovery of "the philosopher's stone," which, in the course of time, was actually acknowledged to exist; and further, that it possessed the property of transmuting the baser metals into gold; that it was an universal remedy for all evils; and its possessor could command prolonged life, health, wealth, and all the happiness he could desire. Nearly all the later alchemists attributed the power of prolonging life to the philosopher's stone or to certain preparations of gold, imagining possibly that the permanence of that metal could be transferred to the human system.

Possessing, as they did, the most implicit faith that such inestimable prizes were within their reach, it is hardly surprising that alchemists should have pursued their fruitless investigations and experiments, during several centuries, with an incredible amount of zeal and perseverance, which was further encouraged by the repeated assertions of several of their fraternity, who pretended that they had accomplished the long-desired object of the transmutation of the metals; while one celebrated alchemist was said, by means of the virtues of his medicines, to have prolonged his life to upwards of a thousand years.

It is seriously related by Dr. Helvetius, the alchemist, that in 1666, having acquired a crumb of stone stated to be the philosopher's stone, and which he believed to possess the property attributed to it, he "was teased by his wife to make the experiment." "Accordingly," the doctor says, "I melted half an ounce of lead, upon which my wife put in the said medicine, when it hissed and bubbled, and in the course of a quarter of an hour the mass of lead was transmuted into fine gold, at which we were much amazed." In this experiment it

can be readily understood that the wife, in order to humour her husband, substituted gold for the lead, employing at the same time some fusible material to produce the hissing and bubbling effect mentioned; and no doubt all the recorded instances of transmutation were due to similar means.

So recently as the year 1782 a Dr. Price, of Guildford, professed, by means of a red and white powder, to convert mercury into gold and silver, and he is said to have convinced many disbelievers of the possibility of such a change. His experiments, however, were to be verified before a competent tribunal, when he put an end to his existence, probably preferring death to an exposure of his fraud.

That alchemy was an alluring fascination there can be no doubt, which was further encouraged by the falsehoods issued at various times to support it; however, the operations of the later alchemists became more advanced, and from their researches important discoveries were made which gradually extended to the modern science of chemistry. The most celebrated of these were Basil Valentine, Paracelsus, and Van Helmont. The first gave the earliest description of, and intelligent directions for, the preparation of nitric, muriatic, and sulphuric acid. To Paracelsus is due the merit of obtaining gas by the action of dilute acid upon limestone, but he failed to appreciate the importance of the discovery. He also propounded the theory that salt, sulphur, and mercury were the constituents of most bodies, or "the true principle of things."

Van Helmont was a native of Brussels, of noble birth, and first directed his attention to the study of alchemy and magic, but, failing to derive any profitable result from these, he left them in disgust. Subsequently he devoted himself to the study of physics generally, at which he laboured incessantly during the greater portion of his life; and on his death-bed he desired his son to collect and publish his descriptions of his experiments and writings, which had hitherto remained unknown. This was accordingly accomplished by the production of the "Opera Omnia," published in 1707.

From this we learn that Van Helmont recognized the existense of other aëiform bodies, which differed in their nature from atmospheric air; and to these he gave the name of "spirit." He observes, "There are bodies which contain this spirit of which they are almost entirely composed, and is therein fixed or solidified, and is made to leave that state by fermentation, as we observe in the fermentation of wine." This spirit he also observed in the combustion of bodies, as well as in decayed organic matter, and as he proceeds in his work he appears to become more confirmed in his views, until we meet with the following extraordinary paragraph, "This spirit, to the present unknown, which is not susceptible of being confined in vessels, not to be reduced to a visible body, I call by the new name of "gas," a term he very probably adopted from "geist," a spirit or ghost. From this point, during the rest of the work, the word gas is always employed to express any aëiform body differing from the atmosphere.

It is remarkable that the knowledge acquired and made public by Van Helmont did not attract the attention of succeeding chemists and philosophers, and that during a century after the publication of his work no additional information on the subject was obtained.

The Honourable Robert Boyle, who lived about the latter part of the sixteenth century, was a great contributor to modern chemistry, and some authors award to him the merit of being the founder of that science. One of his works, the "Sceptic Chemist," was written to refute the salt, sulphur and mercury theory of Paracelsus. In this we find the statements: "It may be possible that any body or substance may be found to contain not only one element in particular, but that it may be composed of two, three, or four different elements. I will first notice to you, that wood for instance, burnt in an open fire in a chimney, is sequestered into ashes and soot, whereas the same wood, distilled in a retort, does yield four other heterogenities (to use a Helmontian expression) and is resolved into oyle, spirit, vinegar, water, and charcoal, the last of which, to be reduced to ashes, requires the being further calcined than it can be in a close vessel."

At that period it should be observed only four elements were recognized, namely, earth, fire, air, and water, and no attempts had hitherto been made to analyze compounds; therefore the experiment may be regarded as the first step towards analytical chemistry, and his observation on the further calcining, approaches closely to the knowledge of the action of the atmosphere on combustibles.

Boyle was the first chemist who produced hydrogen gas, and for this purpose he placed some nails in oil of vitriol and water, when bubbles of "air" were seen to rise into an upper vessel, by which means he believed air identical with that of the atmosphere was produced. This was the first instance of gas being obtained and stored in an unmixed state by a pneumatic appliance.

About this period, 1667, Thomas Shirley communicated to the Royal Society "A description of a well and earth in Lancashire taking fire by a candle approaching to it," in which he gave a detailed account of his attention being directed to an "odd spring," where the people "did affirm that the water of this spring did burn like oyle, into which error they suffered themselves to fall for want of due examination."

The author describes how he proceeded to the well in company with four or five others, when on applying a light to the surface of the water "there was suddenly a large flame produced which burnt vigorously, at the sight of which" his companions began to laugh at him for having doubted their assertions.

On further investigation he observed "that the water at the burning place did heave and boil like water in a pot upon the fire, though my hand put into it perceived it not so much as warm." Eventually the author discovered "a strong breath, or as it were a wind to issue from the earth," which of course was a stream of carburetted hydrogen gas, expelled from the coal in the immediate neighbourhood, similar to the burning fountains. In 1851, when boring for water on Chat Moss, on the line of the Liverpool and Manchester Railway, a stream of gas suddenly issued from the bore.

Some years afterwards, the attention of the Rev. Dr. John Clayton was directed to a well, in the same neighbourhood (near Warrington) as that observed by Shirley, and it is probable that in both instances the same well was examined; when after having caused a hole to be dug, "and the candle being put down into the hole the air caught fire, and continued burning." He says "I got some coal and distilled it in a retort, in an open fire; at first there came over only phlegm" (steam), "afterwards a black oil" (tar), "and likewise a spirit arose which I could in no ways condense, but it forced my lute, and broke my glasses. Once when it had forced my lute, coming close thereto in order to repair it, I observed that the spirit which issued out caught fire at the flame of the candle, and continued burning with violence as it issued out in a stream, which I blew out and lighted alternately several times. I then filled a good many bladders therewith, and might have filled an inconceivable number more, for the spirit continued to rise for several hours, and filled the bladders almost as fast as a man could have blown them with his mouth; and yet the quantity of coals was inconsiderable."

"I kept this spirit in the bladders a considerable time, and endeavoured several ways to condense it, but in vain, and when I had a mind to divert strangers or friends, I have frequently taken one of the bladders and pricked a hole therein with a pin, and compressed gently the bladder near the flame of a candle till it once took fire; it would then continue flaming till all the spirit was compressed out of the bladder; which was the more surprising, because no one could discern any difference between these bladders and those that are filled with common air."

The exact date of these experiments is not known, but they are supposed to have been made about 1680, and in the account of them we have clearly described the first attempts at distilling coal, producing gas therefrom, together with the means of storing and lighting gas.

Several other instances could be related where the gas was known to issue from the earth, and was ignited, without, however, having conveyed any practical lesson.

In 1726, Dr. Stephen Hales published his "Vegetable Statics," in which he describes innumerable substances he operated upon by "dry distillation" (applied, in contradistinction, to evaporation), in order to determine the quantity of "air" they respectively contained. Among these materials are wood, coal, wax, milk, oyster shells, etc., his retort being formed of a musket barrel. The author displayed great ingenuity in his mechanical appliances, as in one of his drawings is represented what we should now term a dry gas-holder, and, singular enough, it bears a strong resemblance to the diaphragm of the dry meter now generally employed. In another drawing the pipe from the retort is bent at an acute angle, and passes beneath the water into the recipient for the gas; thus, as the gas was generated, it forced its way through the liquid, which formed a seal, or lute, to prevent its escape.

From the distillation of 158 grains of Newcastle coal Dr. Hales obtained 180 cubic inches of air, which weighed 51 grains, being nearly one-third of the whole; but his experiments appeared to have been made in order to ascertain the quantity of air each material contained, without doubting whether these varied in their nature the one from the other. He also produced hydrogen gas, and discovered it to be inflammable, from which date it was termed "inflammable air." In Hales' "Analysis of Air," we meet with the following remarks by Sir Isaac Newton, "Is not flame a vapour, or exhalation heated red hot, that is, so hot as to flame? All flaming bodies, as oil, wax, tallow, wood, or coal, by flaming, waste and vanish into burning smoak, which smoak, if the flame be put out, is very thick and visible, and sometimes smells strongly, but in burning, loses its smell by becoming flame, and red hot smoak can have no other appearance."

About the commencement of the eighteenth century a theory was propounded by Becker and Stahl, that heat was a material substance, and that the nature of a body depended on the quantity of heat absorbed by it. According to this theory heat was termed "phlogiston," derived from the Greek word signifying flame, and a chemical writer of the period observes, "There are two kinds of phlogiston; one that is emitted by the substance when burning, as observed in wood or pit coal, and another kind that combines with the substance"—by which we learn that the products of combustion in the one case, were considered to be identical in nature with the caloric absorbed by a metal, the absurdity of which is now obvious. But in other respects the theory was more reasonable; for instance: taking the oxide of zinc and combining it with a certain amount of phlogiston, metallic zinc was obtained, and putting this zinc into nitric acid, it united with the acid and became a calx; but as no inflammable gas was given off, the phlogiston was supposed to remain in the residuum; and to prove that this was actually the case, all that was necessary, was to mix the residuum with any combustible matter and apply heat, when a violent deflagration would occur, accompanied by the evolution of light and flame, in which form the phlogiston was supposed to escape and disappear. However, with all its absurdities, the phlogiston theory was retained for upwards of half a century, and undoubtedly greatly retarded the progress of chemistry.

About the middle of the eighteenth century the production of "air" by the action of dilute acids on iron, as well as the means of expelling it from inflammable substances, such as wood and coal, by distillation, was known to all chemists; and at that period the word "damps," from the Dutch for vapours, was introduced into the English language, and applied to all suffocating, or explosive substances existing in confined localities.

In the year 1764 Dr. Black, of Edinburgh, made the discovery that air (carbonic acid) could be obtained by the action of acids on lime, which, as already stated, had been also accomplished by Paracelsus. On examination the doctor ascertained this production to be entirely dissimilar to common air, and to which he gave the name of "fixed air," implying air which had been *fixed* in the substance from which it was evolved.

Through the accidental circumstance of his living in the immediate neighbourhood of a brewery at Leeds, the attention of the celebrated Dr. Priestley was directed to the "fixed air" or "choke-damp" (carbonic acid), so readily produced in the process of fermentation,



and with which he was induced to amuse himself by making experiments. This eventually led to his study of the composition of atmospheric air, for which purpose he invented several pneumatic appliances, and, among them, the pneumatic trough, with its jars, and sliding trays, as used at the present day in the chemist's laboratory.

Dr. Priestley pursued his investigations into the causes of combustion, the action of respiration, and other points of natural philosophy with remarkable industry, and in August, 1774, he discovered the existence of oxygen gas, and that it formed an important constituent of our atmosphere, which was perhaps the greatest achievement in the annals of chemistry. About the same period Dr. Rutherford discovered nitrogen, the other component of common air, and in 1782 M. Lavoisier, the celebrated French chemist, invented that indispensable apparatus of a gas-works—the gas-holder.

Following these wonderful achievements Cavendish investigated the properties of the inflammable air obtained by Boyle and Hales, and found it to be the lightest of all ponderable matter, and moreover that it was a constituent of water; and, in a communication to the Royal Society, he gave his opinion that this gas "was water deprived of its phlogiston"; subsequently it was discovered that the oxygen of Dr. Priestley combined with the inflammable air, on being mixed and ignited, exploded and produced a quantity of water of exactly the same weight as the gases, and thus was the composition of water determined.

This becoming known to Lavoisier, he resolved to ascertain the composition of water by analysis, and for that purpose passed a stream of steam through a red-hot pipe, when he obtained an inflammable gas, identical with that produced by the action of acids on iron; and he further ascertained, that on this being mixed with oxygen and ignited, it exploded, which confirmed his opinion, and he therefore concluded that hydrogen was evolved and oxygen retained by the iron. Reasoning from analogy that carbon at a high heat has a great affinity for oxygen, he placed some pieces of charcoal in a tube, and when this was heated to redness, on passing the steam, a greater quantity of gas was obtained, although of a somewhat different nature and mixed character.

The fact of gases being explosive becoming known, the first practical use to which they were proposed to be applied was to obtain motive power, and for this purpose several patents were obtained.

The name of "gas" was adopted in Macquer's dictionary, published in 1771, and afterwards applied by Lavoisier and his collaborateurs when deciding on a chemical nomenclature, and is now admitted into every language in the world.

The idea of applying gas to the purpose of lighting, and thus replacing lamps and candles, was first entertained by Mr. W. Murdock, an engineer, of Redruth, in Cornwall, in the year 1792. He subsequently made various experiments on different kinds of coal, with the view of arriving at the means of depriving the gas of its impurities, and the best method of burning it, and lighted his house and a street lamp with gas. We are further informed by Matthews, that "he had bladders filled with gas to carry at night, with which, and his little steam carriage running on the road, he used to astonish the people there." That Murdock was a man of great abilities there can be no doubt, but the construction of the steam carriage is exceedingly questionable, as such an innovation at that time would have excited universal attention, besides, he makes no mention of it himself. Murdock, in 1798, was engaged by the firm of Messrs. Boulton and Watt, of the Soho Works, Birmingham, when he erected an apparatus to light a small portion of the premises, and in 1802, on the occasion of the peace of Amiens, he lighted the whole of the front of the Soho Works with gas devices, and from that period the firm of Boulton and Watt began to combine the manufacture of gas apparatus with their other extensive business.

The first dwelling lighted by gas in England, apart from those where it was tried experimentally, was that of Mr. Lee, of the firm of Lee and Phillips, extensive mill owners at Manchester, in 1804, where it was tested for some months, in order to ascertain its salubrity and other properties, before introducing it into the cotton mills of the firm. The following

year part of their manufactory was lighted by the means in question, and the whole completed in 1806. The number of burners then employed was 271 Argand, and 653 Cockspur burners.

In 1801 a French gentleman, named Lebon, obtained a patent in France for lighting with gas, which he carried into operation in the autumn of the same year, at a house in Paris; but he does not appear to have derived any substantial compensation for his abilities, as gas lighting was not introduced into that city for several years afterwards.

In January, 1804, Winsor, a German, introduced the means of lighting by gas before the British public at the Lyceum Theatre in London, where he lectured, showing its advantages; and the same year obtained a patent for improvements in the means of making gas. Possessing this, he endeavoured to form a company, which he was bold enough to propose should have the privilege of supplying the whole of the British Possessions with gas. Winsor's extravagances and absurdities have been frequently presented; therefore all that need be stated is, that he was a bold, wild enthusiast, who was never discouraged, never disheartened, but continued his career with the same *sans froid* he displayed, when he personally lighted the first lamps placed in Pall Mall, in 1807; and a writer observes, whether the boys cheered him when the gas was lighted, or hooted him under opposite conditions, it was all the same to him.

Eventually, Winsor, having a number of subscribers consisting of gentlemen of position, petitioned the King in Privy Council, to be incorporated. It was then decided that His Majesty could not grant the charter of incorporation until an Act of Parliament was obtained authorizing the Company.

In 1809 the first application was made to Parliament by Winsor and his subscribers, as a gas-light company, under the title of "The National Light and Heat Company," with a capital of £500,000, and, to have the exclusive privilege of supplying the whole of London with gas.

This application was opposed by Murdock and Watt, on the ground of priority of the application of gas-lighting by those gentlemen, also on account of the probable interruption to their business as manufacturers of gas apparatus. After an enquiry before a Committee of the House of Commons, which lasted several weeks, the application was rejected.

The next year, 1810, Winsor and his friends again applied to Parliament to be incorporated as "The London and Westminster Gas-light and Coke Company," with a capital of £200,000, the powers of the Company to be limited to London, Westminster, Southwark, and the suburbs; and although great opposition was experienced, the necessary Act was passed, and two years afterwards the Company obtained the Royal Charter, from which period it was called "The Chartered Gas-light and Coke Company."

The Company established, the first premises taken were a wharf near Westminster Bridge, a portion of the site now occupied by the Civil Service Commission. From there they removed to Peter Street, Westminster, and on the 31st of December, 1813, Westminster Bridge was lighted with gas, when it became an object of attraction, and while the novelty lasted it was a fashionable promenade. About the same period other works were established by the company at Brick Lane, St. Luke's, and Curtain Road, Shoreditch.

The first practical application of gas-lighting was so successful that another company was established in 1814 to light a portion of the City of London. Their first premises were erected in a yard in an obscure but thickly-populated neighbourhood, and, like the other works mentioned, at a considerable distance from the river or water communication, but in consequence of the nuisance arising from their operations the parish authorities commenced legal proceedings, when the company reluctantly took other premises adjoining the Thames at Blackfriars.

The South London, afterwards called the Phoenix Company, was added to the Metropolitan companies in 1816, and, following the example of their predecessors, established their works in St. George's-in-the-Fields at a considerable distance from the river; which

circumstance clearly proves the slight degree of importance attached to the future development of Gas-lighting, as it is only natural to suppose that, if any magnitude in their operations were anticipated, the company would have established their premises either adjoining a river or canal, in order to facilitate the transport of coals and other materials required for their operations.

In 1815 Acum produced the first edition of his "Treatise on Gas-lights," one half of which was devoted to the best method of burning candles. The same year Clegg patented his gas-meter, which, although not a practical machine, was unquestionably the origin of the instrument now generally employed and known as the wet meter.

The method universally employed for purifying gas during many years was by means of the "cream of lime," but in 1817 Reuben Phillips, of Exeter, patented the dry lime process, which system, although now extensively adopted, remained comparatively unnoticed by gas companies for upwards of twenty years. This, however, is not more surprising than the fact that several companies positively prohibited the use of the gas-meter in their districts thirty years after it had been practically adopted.

About 1817 the Imperial and British Gas Companies first commenced operations in the Metropolis, and other companies were formed for lighting various cities and large towns in the United Kingdom. Four or five years later considerable excitement was created by the announcement of several scientific gentlemen of the superiority of oil gas over coal gas, as also the statement of the insalubrity of the latter when employed in dwellings. As a natural result, at many cities and towns—among them Edinburgh, Liverpool, Dublin, Bristol, Hull, Taunton, Plymouth, and Norwich—it was decided to adopt oil gas for lighting the respective places, and works for that purpose were erected. This degree of success encouraged the parties most interested to apply to Parliament in 1823 for an Act to incorporate "The London and Westminster Oil Gas Company," empowering them to raise a capital of £400,000, and to manufacture and supply oil gas in the cities of London and Westminster. This, however, was successfully opposed by the gas companies, after a long investigation, at a cost of about £30,000.

Gas-lighting was first introduced into Paris in the year 1812, when Count Chabrol de Volvie ordered a small gas-works for supplying the Hospital St. Louis, where he entered into some experiments on the purification of gas. In 1816 Winsor endeavoured to establish gas-lighting in that city, but beyond lighting an arcade called the "*Passage des panoramas*," he was not successful. In 1820, by order of the Government, Pauwells constructed a works to light the Palace of Luxemburg, and from these works the gas was conveyed to the Odeon Theatre, which was the first lighted by gas in France. Shortly after this two gas-works were erected simultaneously for supplying Paris with gas, one of which was the property of a French company founded by Pauwells, the other belonging to an English company established by Manby and Wilson.

The Impèrial Continental Gas Company was founded about 1824, and at that time Sir William Congreve, who had been Government Inspector of Gas-works, visited the Continent with the view of advancing the use of Gas-lighting. Hence establishments were formed at Berlin, Hanover, Amsterdam, Rotterdam, and Ghent, in some of which oil gas was adopted. In 1827 the Edinburgh Oil Gas Company applied for an Act to enable them to obtain new capital, and to alter their works for the production of coal gas, when it was given in evidence that in the five years of their operations their loss was nearly £60,000, and the loss of gas from condensation and leakage was no less than 36 per cent. Various other establishments had previously abandoned the manufacture of oil gas, the Edinburgh company being among the last that retained the ruinous system. At this time the number of gas-works in the United Kingdom had increased to about a hundred, with a total capital of less than ten millions.

From that period gas-lighting has extended to almost every town and city of importance throughout the civilized world, whilst in England there are many places having

a population of 800 or 1000 inhabitants, and in Scotland with 400 persons, which have gas-works for their exclusive supply, and in only a few solitary cases are they otherwise than profitable, which circumstance generally arises from the apparatus being imperfectly constructed in the first instance, and the want of experience in the manufacture and distribution of gas.

---

## ADVANTAGES OF GAS.

NOTWITHSTANDING that gas lighting has made such extraordinary progress during the comparatively few years it has been in operation, it is far from having attained that universal application to which its various advantages entitle it. Firstly, as regards the cost: taking the average price throughout the kingdom, for any given quantity of light supplied, gas lighting is about one twentieth part of the cost of wax candles, one sixth the price of tallow, one fifth that of common oil, and half the cost of the most ordinary kind of paraffin oil; or, in other words with gas, the light of six tallow candles can be had for the cost of one; all the other materials, as compared with gas, following in the proportions stated.

Gas is beyond all comparison safer than any other means of artificial light, as proved in all parts wherever it is adopted; and with respect to cleanliness, facility of application, the absence of labour in cleaning and preparing lamps—on all these accounts gas-lighting possesses the superiority. Besides, when this is employed no provision or store is necessary, as it comes instantly when demanded, and is as readily dispensed with when no longer required.

The light from gas is unquestionably more agreeable than that from candles and lamps; its position, when properly placed, is above the line of vision, so that the eyes are protected from its direct rays; moreover, it can be augmented or diminished at pleasure, thus preventing the straining of the eyes, which is so injurious, whenever an insufficiency or excess of light exists.

In short, gas is as superior to all other means of lighting, as the railway is to the stage-coach; as steam is to manual labour or to sailing navigation; or as the electric telegraph is to the old signal system; and its benefits are such, which only those who have left the obscurity of the candle, or lamp, for the light of gas can fully appreciate.

Further, if any proof be requisite to substantiate these assertions, it exists in the very general application of gas, alike in the palace as in the cottage. It is adopted in manufactories of every denomination; in churches, chapels, public halls, theatres, hospitals, barracks, warehouses, clubs, schools: indeed, in every place wherever artificial light is required, and gas can be obtained, and in some instances it is kept burning continuously both day and night. Therefore, with these facts in view it is evident, by the introduction of gas into hospitals, that the health of the most delicate cannot be impaired by its use; and by its adoption in other localities we have the proof that furniture and decorations or the goods stored therein, are not affected by its employment, so long as the most ordinary care as regards ventilation is observed; and consequently the great desirability and utility of gas is fully established.

But with all its numerous advantages, much remains to be accomplished before the use of gas is properly developed, and this is particularly remarkable abroad, where there are many towns having a population of 20,000 inhabitants, and upwards, where gas-lighting is not yet adopted, and where it only requires to be proposed by some enterprising person in order to be established, alike to the advantage of the locality, the shareholders, and all concerned.

In most foreign countries exclusive privileges, or concessions, are granted for lighting the towns, which concessions vary from fifteen to fifty years' duration, in which the price of gas is arranged; and the authorities undertake to pay a given sum per annum for the supply of a certain number of lights during a given number of hours, which amount constitutes a sure rental and is a great consideration in the concessions, and the authorities generally reserve to themselves the right of purchasing the works, plant, mains, etc., at the termination of the concession, at the value to be fixed by arbitrators. Sometimes the government grants the ground necessary for the works, gratuitously, or at a nominal rent, and permits all the apparatus and mains to enter free of duty.

In the choice of the site of a works, it is desirable to avoid, as far as possible, any unnecessary expense of transport of the coals; and for this object water-side or railway communication is essential. The works should be situated at some distance from the best part of the town in order to avoid the possibility of complaint on sanitary grounds; at the same time, they should be situated at a convenient distance, for the facility of ensuring ready communication with the consumers, as well as to avoid unnecessary expenditure in the mains.

A]  
**PATENT PORTABLE GAS APPARATUS,**  
*For Mansions, Villas, Manufactories, Railway Stations, etc.,*

INVENTED AND MANUFACTURED BY

**GEORGE BOWER,**

ENGINEER AND CONTRACTOR, ST. NEOTS, HUNTS.

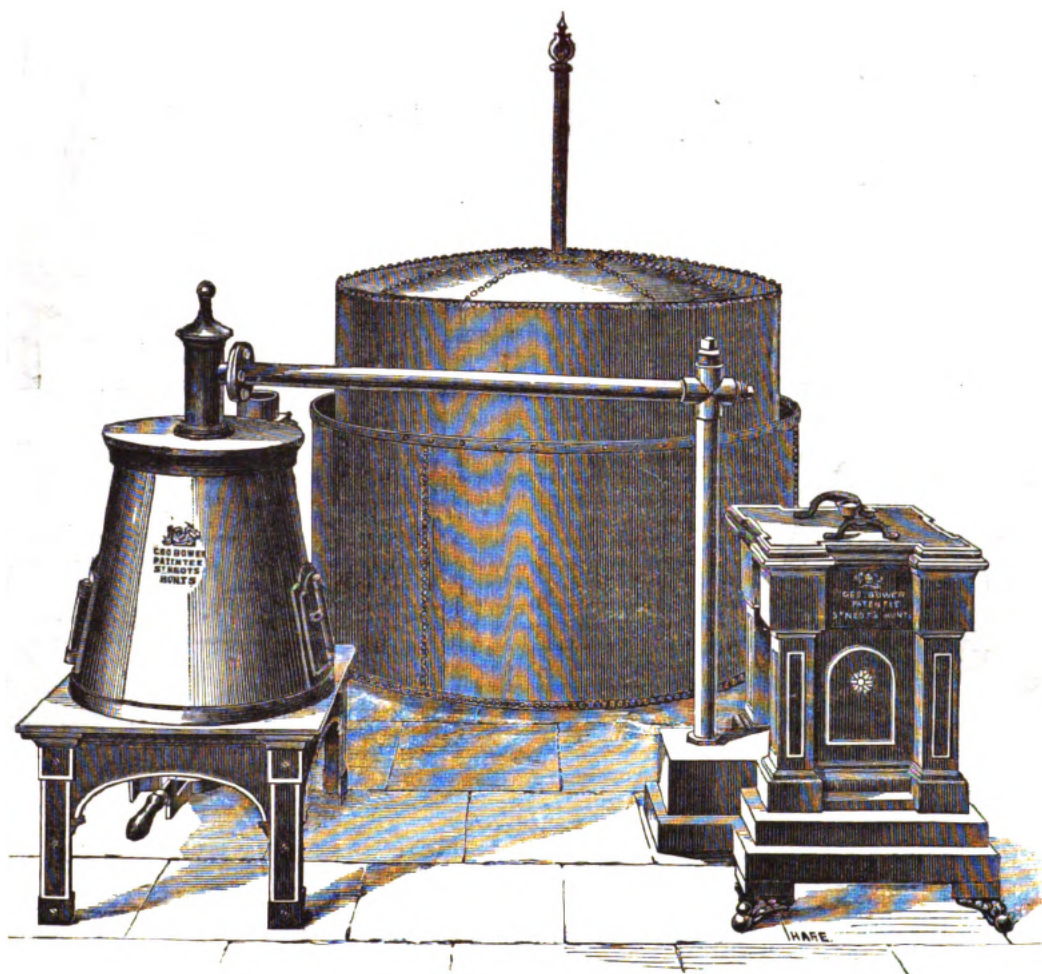

PORTABLE AND EXPERIMENTAL GAS APPARATUS.

The above engraving represents a Portable Apparatus suitable for experimental purposes, or to supply from 5 to 8 lights, and consists of a retort with all its accessories, set vertically in brick-work and enclosed within a cast-iron case; a combined purifying apparatus; and a gas-holder with its tank—the whole forming a complete apparatus for the objects mentioned, and is to be recommended on account of its simplicity, the limited wear and tear, and the facility of management, as any ordinary labourer or domestic servant is capable of working it. Its principal advantages are:

It requires but little labour to manage.

The fire may be lighted and extinguished with the same facility and freedom from inconvenience as an ordinary shop, or hall stove.

A retort, when worn out, can be replaced by a new one without the assistance of a skilled mechanic.

GEORGE BOWER, ST. NEOTS, HUNTINGDONSHIRE.

The quantity of fuel required to heat it small, as with an apparatus of larger dimensions than that shewn (suitable for 50 lights), when kept regularly at work, and carbonizing Newcastle coal, the coke obtained will be almost sufficient to keep the retort at a proper heat.

No fire bricks are required for setting the retort other than those supplied.

The apparatus is adapted for the production of gas from coal, wood, peat, or cannel.

The following drawings show different views of the retort :—

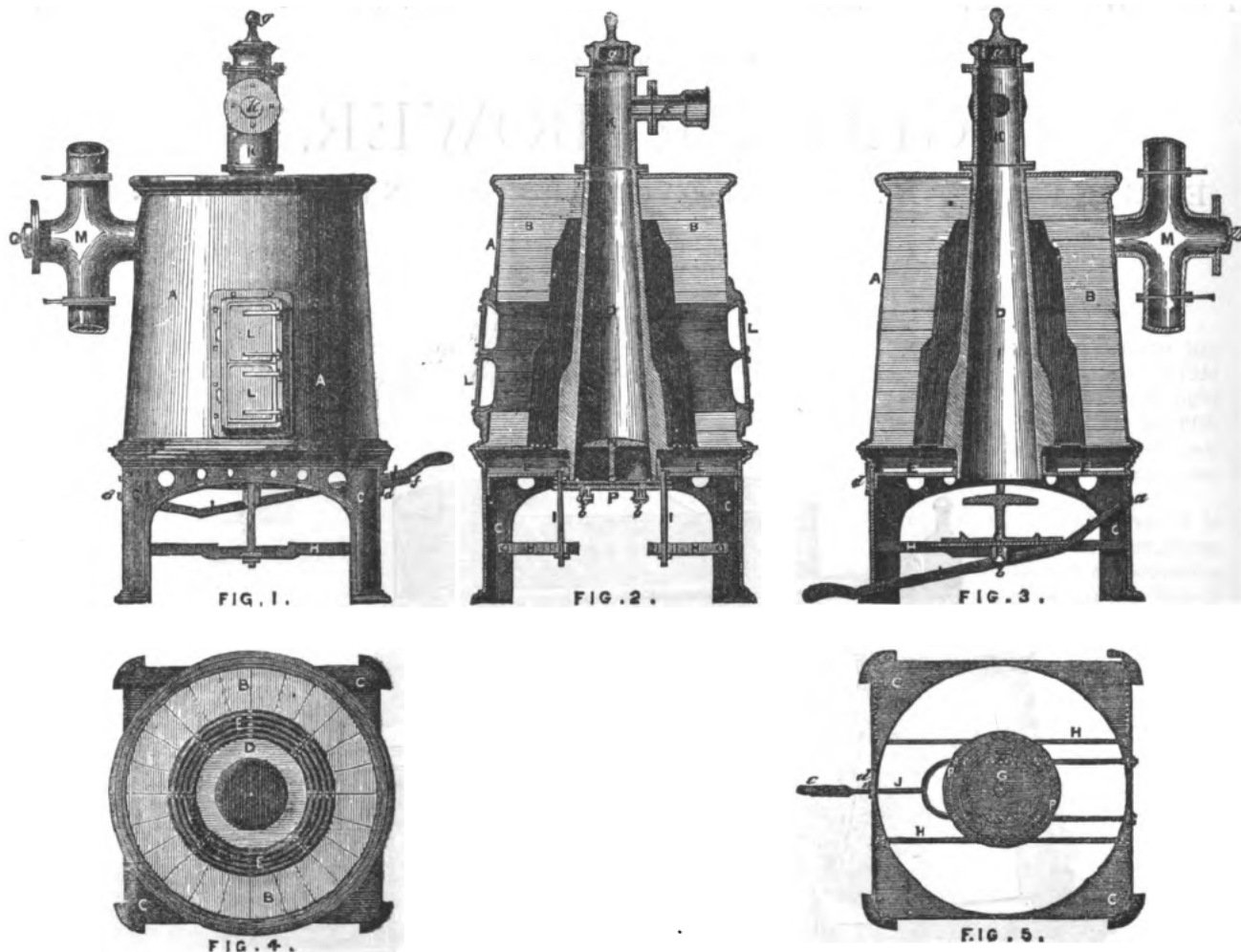

PLANS AND SECTIONS OF VERTICAL GAS RETORT.

DESCRIPTION.

The apparatus consists of a conical retort, set vertically in a furnace or fuel chamber, and is open both at top and bottom ; the top is closed by a luted plug G, and the bottom by a luted lid, projecting from which is a disc plate N, which receives the coal at a level slightly above that of the fire-bars, and consequently retains it in contact with the red-hot surface : the door is placed on a plate fitted to horizontal parallel bars H, and which are fixed to the framework C ; it is raised to its proper position by means of a forked bent lever J, and kept in position by a swing catch and wedge : on removing the wedge and lowering the lever J by the handle c, the door and plate return to their original position on the horizontal bars.

To charge the retort, nothing more is required than to fill a hopper (supplied with the apparatus) with dry coal or cannel, and to let it run into the retort, after the bottom door has been luted and raised into its position ; the top is then closed by a luted plug ; care must be taken, however, that the retort is at a bright red heat before introducing the coal, as a dull red heat produces much tar and but little gas.

REFERENCE TO ENGRAVINGS.

Figure 1 is an elevation ; figs. 2 and 3 sectional elevations at right angles to each other ; fig. 4 is a plan in section immediately above the fire bars, and fig. 5 is a plan showing the arrangements for raising and lowering the bottom door. A is the outer case, B are the moulded fire-bricks lining the interior of case, C is the frame supporting the apparatus, D is the retort, E the fire-bars, H the longitudinal parallel bars, I I guides for the door whilst being raised and lowered, J the forked lever, K the outlet from retort, L L the furnace doors, M the smoke pipe, G the bottom door, and N the projecting disc, P is a plate carrying the door, d is the swing catch and wedge, g the luted plug closing the top of retort.

These apparatus are made of five different dimensions, the smallest, as already described, being for from 5 to 8 lights, and the largest from 40 to 50 lights burning four hours. Their specifications, weights, and measurements, are given in Section L.

DOUBLE-ACTING RETORT APPARATUS SUITABLE FOR THE  
MANUFACTURE OF GAS FROM BOTH SOLIDS AND LIQUIDS.

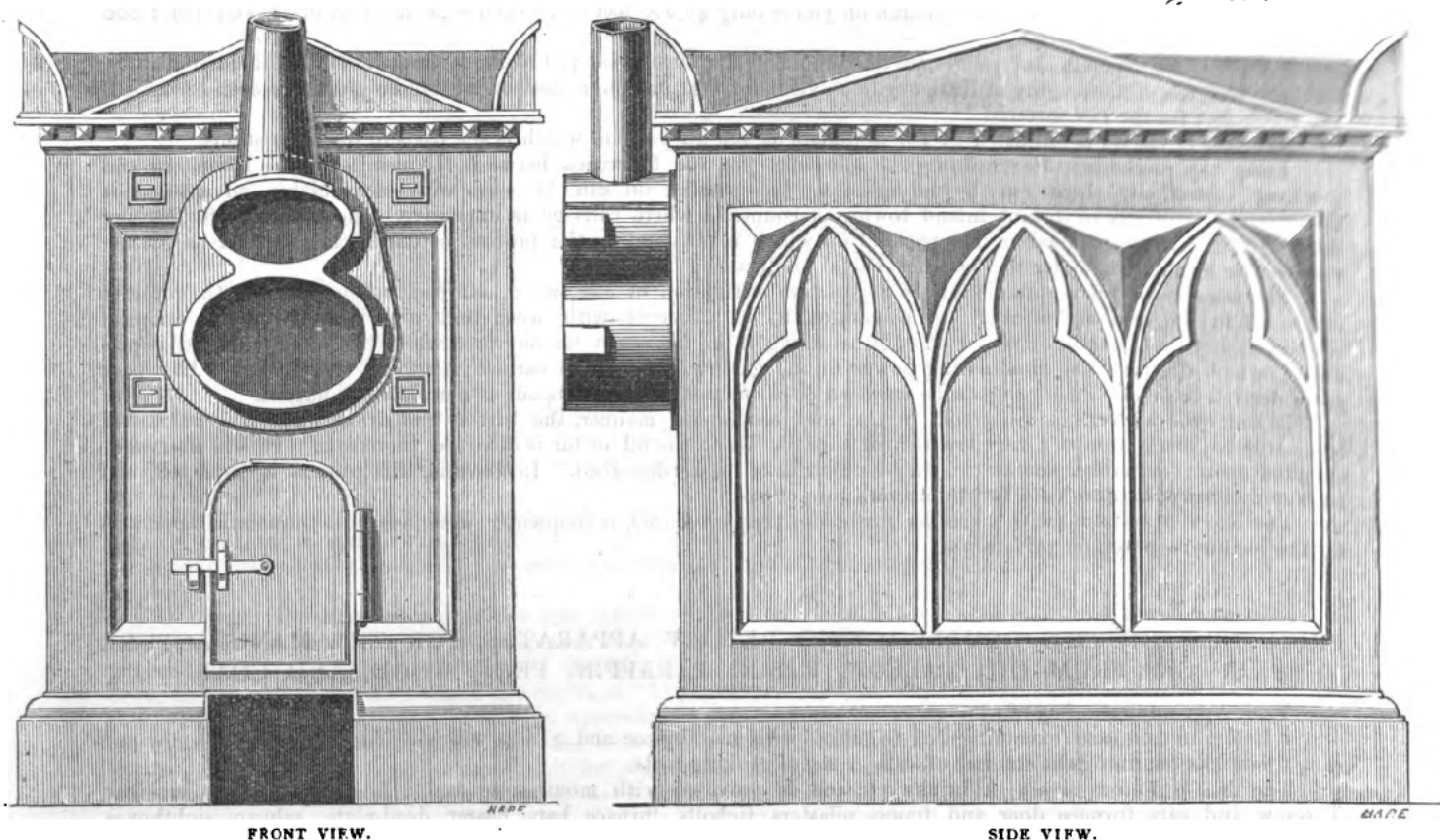

FRONT VIEW.

SIDE VIEW.

There are many localities where the price of coal is excessive, but where oil or petroleum can be obtained at a moderate cost, and may be advantageously employed for the manufacture of gas; for which purpose the principal consideration is the most suitable kind of retort for both solids and liquids.

When tallow or resin is used for the object in question the material is placed in a suitable tank, at a higher elevation than the retort, covered in order to prevent dust intermixing therewith, and heated to that degree that the material becomes fluid. This accomplished, the operation of distilling, whatever may be the nature of the substance, is identically alike in all cases, as hereafter explained.

For manufacturing gas from oil, the double retort represented in the annexed engravings is especially adapted. In this a communication exists at the further end between the two retorts; thus the vapours have to pass their entire length before reaching the ascension pipe. Attached to the door of the lower retort is a bent syphon pipe of wrought iron, having a funnel for the admission of the fluid into the retort, and a pipe from the tank or reservoir, provided with an adjusting tap, conveys the oil into the funnel. By these means the fluid for decomposition is supplied, and the escape of gas at that point avoided. When required for making gas from oils, the retorts may be charged with broken bricks or similar material, which exposes a large surface to the passing vapours, the doors are luted, and when the retorts and their contents are brought to a good red heat, the oil is then allowed to flow from its tank very gently into the funnel, from whence it passes to the retort. In this operation care must be observed to avoid an excessive supply of oil, as when this is allowed in excess of the proper quantity the apparatus is capable of decomposing, the result is that only a very small portion of the material is converted into gas, and the rest condenses into its liquid state. But when only the required quantity is allowed to pass into the lower retort, it is immediately converted into vapour, and this coming into contact with the red-hot surface of the retort and bricks, is decomposed and converted into gas, and any portion which escapes decomposition in the lower retort is effectually operated upon in the upper division. Resin, or fat, in a fluid state, can be treated in a similar manner.

The apparatus is represented with the retort enclosed in brickwork, and the whole encased in a cast iron frame, by which arrangement, a small quantity of brickwork is required; radiation of heat is diminished; and the apparatus possesses the further advantage that it can be placed in any locality without being unsightly.

With reference to the production of gas from petroleum, according to the experiments of Dr. Macadam, "the most permanent gas is obtained at high heats; as when 23,240 feet of gas of 34.76 candles per 5 cubic feet were obtained from one ton of paraffin oil, its illuminating power decreased to 27.68 candles the second day, and

25·43 candles the fourth day. Thus it appears that if the gas is consumed the day it is produced, the higher illuminating power may be assured, but it decreases in value by storage in the proportion stated.

"Making allowance for the condensation of the oily vapours, when the gas is stored for several days in the gas-holders, one ton of crude shale or paraffin oil yields fully 46,000 feet of 25 candle gas at a cost of 1s. 10d. per 1,000 feet of gas for the raw material.

"That these experimental results are still short of the theoretical yield of gas from the crude shale or paraffin oil; for one ton, if thoroughly utilized, ought to yield fully 63,000 cubic feet of 25 candle gas at a cost of 1s. 4d. per 1,000 feet for the raw material."

The cost of the oil is estimated by Dr. Macadam at £4 4s. per ton, which is the basis of his calculations.

From the preceding, after making due allowance for the difference between the results of the laboratory and practical operations, there can be no question but paraffin oil can be used with considerable advantage for the production of gas in distant inland towns, in countries where carriage is expensive, when the fuel for heating the retort may either be wood, or the residual oil which is obtained in the process of distillation, applied as recommended for burning tar under the head of residual products."

The same apparatus is suitable for the destructive distillation of coal, wood, and peat, when of course the retort is employed in the ordinary manner. A precaution to be observed with wood and peat is to draw the charcoal whenever the useful gas is driven off, for by retaining it in the retort for any protracted time carbonic acid is produced, which destroys the illuminating power of the gas evolved in the earliest stages of the process. The poor gases derived from wood and peat can be enriched or carburated with the vapour of petroleum or naphtha.

In order to produce gas from turf in the most economical manner, the turf is first dried, when it is submitted to destructive distillation at a very low temperature, by which the oil or tar is obtained therefrom. This is afterwards operated upon in a manner similar to the distillation of oil as described. In Bavaria, this process is employed, and large quantities of turf are used for the manufacture of gas.

The No. 1 Apparatus (with a smaller gas-holder than specified), is frequently used as an experimental apparatus for the lecture room, or for private use.

PRICE LIST OF THE DOUBLE-ACTING RETORT APPARATUS, FOR THE MANUFACTURE OF GAS FROM OIL, TALLOW, RESIN, PARAFFIN, PEAT, WOOD, AND COAL.

Each Apparatus consists of :—

1 Retort in iron case (excepting No. 6), fitted with mouthpiece and 2 lids, wrought iron crossbars, T screw and ears, fire-bricks for lining the interior of case, 1 set of stoking tools.

The No. 6 Retort is set in brickwork, and is provided with mouthpiece and 2 lids, wrought iron crossbar, T screw and ears, furnace door and frame, pilasters, tiebolts, furnace bars, bearer, dead-plate, ashpan, sightboxes, damper, tile and rod, saddle pipe, ascension pipe, dip pipe, etc.

1 Combined Apparatus, consisting of air condenser and purifier, fitted with lid, sieves, syphon pipes, connecting pipe from retort, etc.

1 Gas-holder of sheet iron, with internal framing, guide columns, holding down bolts and plates, wrought iron girders for tops of columns, guide rollers, chains and pulleys, balance weights, syphon boxes, suction pipes, syphon pump, connecting pipe from combined apparatus into and out of gas-holder, stop valve, paint, bolts, cement, etc.

Number of Apparatus.	Number of burners suitable for each, burning for 4 hours, and giving a light equal to 10 ordinary candles.	Character of Setting.	Cubic feet of Gas each retort will produce per hour from petroleum or common oil.		Size of covered building required for Retort House.	Size of combined purifying Apparatus.		Size of covered building required for combined Apparatus.		Size of Gas-holder.	Number of Guide columns.	Size of connecting pipe.		If Gas-holder is self-sustaining or counter-balanced.	Number of stop valves.	Price of Apparatus with Gas-holder, delivered at the Docks in London, Liverpool, or Hull, inclusive of packing cases.			Price of Iron tanks for Gas-holder, delivered at the Docks in London, Liverpool, or Hull.		
			ft.	ft.		No. 000	ft.	ft.	dia. ft.			depth ft.	inches bore			£	s.	d.	£	s.	d.
1	6	in iron case	4	..	ft. ft.	No. 000	ft. ft.	dia. depth ft. ft.	5 by 2½	1	1	¼	self-sustaining counter-balanced	2	18	0	0	£	s.	d.	Iron tank included in price of apparatus
2	18	"	12	4 by 4	0	4½ by 4½	6	6	6	3	1½	1	"	1	47	0	0	10	0	0	0
3	40	"	28	5	5	1	5	5	8	3	2	2	"	1	70	0	0	17	10	0	0
4	70	"	48	6	6	1	5	5	10	3	2	2	"	1	86	0	0	30	0	0	0
5	100	"	80	8	8	2	7	5	12	3	2	2	"	1	95	0	0	60	0	0	0
6	200	in brickwork	150	20	8	3	7	7	15	3	2	2	"	1	180	0	0	90	0	0	0



Plans and instructions for fixing are sent when required. The gas-holders are rivetted together in pieces, suitable for transport or shipment, and each piece is plainly marked or numbered, so that no mistake can occur in fixing. The smallest sizes of the gas-holders are sent whole.

In inquiring for prices, it is necessary to state the maximum number of lights, and the longest time they will be required to burn per day, during winter; it should also be stated what material the gas is intended to be made from.

A complete oil gas plant has been supplied to the Indian Government for Rawal Pindée, to make gas from the native oil found in the district. The plant will supply several thousand lights.

### Carbonization.

The destructive distillation or, as more generally termed, the carbonization of coal, in a commercial point of view, is the most important of all the operations connected with the manufacture of gas, and in many instances, the question of profit, or loss, mainly depends on the manner the process under consideration is effected.

In order to explain this, it may be first observed, that according to the degree of heat to which the coal is submitted, when undergoing distillation, so will be the products, whether the quantity of tar, or gas, predominates. Thus with the retorts at a comparatively low temperature of about 600° Fahr., that is, a degree of heat only just perceptible in a completely darkened room, the point at which lead melts; when coal is subjected to that temperature nearly all its volatile constituents are resolved into tar, with the evolution of only a very limited quantity of gas, which under some conditions does not exceed a few hundred feet per ton. This process is adopted in the manufacture of paraffin oil from coal, for which purpose the tar or oil is afterwards treated with sulphuric acid and alkalis, and redistilled.

But as the heat of the retorts is augmented, so is the yield of gas per ton of coal increased in a proportionate manner, until the temperature of 2010° Fahr., or as called from its colour "dull orange," is attained; which for the production of gas is considered the most advantageous, and is that most generally adopted when clay retorts are employed.

Confining my observations in the first instance to iron retorts, with a view to their preservation and durability, and obtaining a good yield of gas, these are required to be worked at a lower temperature than those of clay, and generally the heat considered the most desirable for iron retorts, alike for the proper yield of gas, to obtain good coke, and to ensure the duration of the retort, is "bright cherry" red, or 1830° Fahr. This description, however, is somewhat vague, but a better means of appreciating the temperature is by referring to the colour of new red bricks, as used in decorative building—the iron retort, when heated and seen by ordinary day light, of that colour, is in the most suitable condition for manufacturing gas. At a somewhat higher temperature, 1869°, brass melts, and at 1996° copper melts, and cast-iron melts at 2786°.

In carbonizing, the charge of coal should be moderate; otherwise, if the retort be overcharged, a dense black smoke is formed at the moment of placing the lid of the retort, which is nothing more than the volatile constituents of the coal passing off as the vapours of tar. Another precaution to be observed, is to draw the coke wherever it becomes thoroughly incandescent, as by retaining it within the retort after the useful gas is emitted, other gases are delivered, although in small quantities, which deteriorate materially that first obtained: and from this arises the sulphur compounds, which often occasion so much trouble in removing in the operation of purification.

In the process of carbonization, during the greater portion of the time the coal is in the retort, it remains without any material elevation of temperature; shortly after the retort is charged (supposing caking coal to be employed) the coal commences to swell, delivering the gas, which carries off the heat communicated from the furnace—very similar in action to an ordinary kettle when boiling, which delivers the heat absorbed by the water in the form of steam which issues from its spout; thus only when nearly all the volatile constituents or useful gas is emitted from the coal, does the temperature of the mass of carbon increase. The coke is then formed, all the little pores of which have served as passages for the egress of the gas during carbonization.

With all retorts, whether they be of iron or clay, it is of the utmost importance that their interior should be kept as free as possible from carbon incrustation, as this in addition to occupying a space that should be available for the coal, presents a non-conducting substance, and obstruction, to the passage of the caloric from the furnace to the coal undergoing carbonization; which not only increases the expense of fuel for the furnaces and labour, but offers great facilities for the destruction of the retort by the heat. To clear the carbon from the interior of the retorts, they are allowed to "stand off" or remain uncharged for a few hours, but maintaining the heat in the usual way and placing the lid unluted, with an opening of about a quarter of an inch between it and the mouth piece, through which air enters at the lower part, and after combining with the carbon in the retort, passes off at the upper part in the form of carbonic acid, or carbonic oxide, and, sometimes with particles of incandescent carbon or sparks. By these means a retort may be generally cleared from carbon in a few hours, and when there are two or more in a setting, one can be allowed to stand off for clearing whilst the others are in action. The operation may be accelerated by blowing air into the retorts.

Another consideration with iron retorts is, that facilities should be afforded to cleanse them from the carburet of iron, which forms itself on their exterior. For this object sight holes are provided in the front of the setting, and through these sight holes, a rake is passed by which the carburet of iron is removed. The objection to the presence of the carburet is its great non-conducting influence to the passage of the heat.

The ash pans of the furnaces should be properly supplied with water, as the steam arising from this serves to preserve the furnace bars. The furnaces should be clinkered on the average once in twelve hours, in order that a proper current of air may always pass into the furnace; and to ensure economy of fuel for carbonizing, the greatest care should be observed to avoid any loss or waste of heat, or fuel (which is the same thing) from passing off by the damper into the atmosphere. For this object, the dampers should be so arranged as to be under the control of the workman without moving from the firing floor; and in all cases the damper should only be open to the extent required to give the necessary draught, and wherever this is exceeded, loss of fuel for carbonization is the result, which loss becomes very important when there is a strong current or draught in the furnaces.

Iron retorts are the most suitable for very small works, as they possess the advantage that they do not crack and allow the gas to escape; they are better conductors of heat than the others; they may be allowed to cool down and be again heated without any fear of their leaking, but for this object they should be free from carbon in the interior. Hence it is always advisable to clear this from a retort, before it is allowed to cool, otherwise a mass of carbon adheres to the iron; and as the latter contracts very materially on cooling, and carbon does not, the retort is often cracked and sometimes in several places, and thus rendered useless. When properly set, and observing the ordinary precautions indicated, the durability of iron retorts will be considerable, but mainly depending on the temperature at which they are worked. It is, however, always unwise to endeavour to obtain durability of the retort at the expense of the gas, for it is better to obtain the full yield of gas from the coal, and for this object the proper temperature of the retorts is the first consideration.

All coals destined for carbonization should be kept dry, the loss arising both in the quantity and quality of the gas and coke derived from wet coal being very considerable. Coals which are a long time in store, even when kept dry, deteriorate in value alike for the purpose of making gas and coke.

The coal used in the operations of the retort-house should always be weighed, and a regular account kept of each charge, and recorded in the carbonizing book. This is more particularly necessary in small works, where it is more difficult to earn a dividend for the shareholders than in larger establishments.

The yield of gas from coal, when undergoing the process of carbonization, is very variable according to the quality of the coal and other circumstances. For instance, some of the richest cannels approach resin in volatility; and necessarily with this, as with all other rich cannels, the largest yield is obtained during the first hour, each consecutive hour diminishing in its yield until the last, during which the production of gas is small.

Again with wet caking coal, or when the retorts are overcharged, the first hour is not the most productive, as in the first case the caloric of the settings, instead of being employed to expel the gas, serves to expel the steam, and in some cases, where an excess of water exists, the temperature of the retort is lowered considerably, and tar produced. When the retorts are overcharged it is always made palpable by the dark thick heavy smoke issuing from the coal, occasioned by the presence of tarry vapours, which become condensed, and tar is obtained instead of gas. Therefore it is evident that any table giving the amount of gas produced during different hours of the charge must be governed by numerous circumstances, but above all by the quality of the coal carbonized. However, taking the average workings with the average of caking coal, the first hour is slightly more productive than the second, and a gradual diminution follows until the last hour, when a marked reduction takes place, and at this period, in consequence of the small quantity of gas yielded, the coke acquires its incandescence.

In some localities where tar is unsaleable it is employed as fuel for the furnace, by which the coke is economized. For this purpose, according to one process a stream of tar is caused to flow through an orifice immediately over the furnace door on to the coke in the furnace. But by another system the furnace is fed entirely by the tar, in which case the ash pan is filled with lime or other material, and the door of the furnace is bricked up a thickness of nine inches, and at the lowest part of the brickwork and in the centre of the brickwork is left an orifice of about two inches square, and at the uppermost part also in the centre is left a similar orifice. When applied to old settings the whole of the change can be made in an hour. The ash pan and furnace are then filled with lime up to the level of the lower orifice. This accomplished, a stream of tar of about a tenth of an inch thick is conveyed into the furnace by a gutter formed of angle iron passed into the upper orifice, which produces a vivid flame. A portion of the tar falls opposite to the lower orifice, and by the combined agency of the flame of the upper orifice and the incandescent fuel at the bottom, the settings are heated entirely without coke. The combustion is improved by allowing water to drop with the tar.

The imperfect knowledge of the pernicious effects of high pressure, together with the ignorance of the cause of the deposit of carbon in the retorts during the process of carbonization, induced gas engineers about twenty five years ago to adopt the use of clay retorts. That these are decidedly preferable to iron for works of magnitude, and indeed for all except those of the most limited description, there can be no doubt; as by the use of the exhauster, both the evil effects of high pressure as regards leakage, and the deposit of carbon within the retorts, are avoided.

However, clay retorts permit of a high degree of temperature being employed, by which a larger yield of gas, although of slightly diminished value, and a harder kind of coke, are obtained. They are also more durable than iron retorts. By the use of clay retorts a greater quantity of gas is produced from a setting of any given capacity: they are cheaper than iron in the first instance, while their average cost for setting, etc., per 1000 feet of gas produced, is considerably less than where iron are used.

## ANALYSIS OF COAL.

The following description of the analysis of coal is by Mr. Lewis Thompson, whose reputation as a distinguished chemist is well-known. He says:—

"The first step in the analysis of coal is to determine the quantity of volatile matter and coke that it contains; for this purpose a small iron crucible provided with a cover perforated with a hole may be employed. The coal to be examined should be a fair sample, that is, pieces detached from various lumps, of which 100 grains are carefully weighed out, and introduced into the crucible, when the cover is placed, and the whole is submitted to a bright red heat, until all evolution of inflammable gas has ceased to issue through the aperture in the cover. The crucible is then removed from the fire and allowed to cool, after which the coke is taken out and weighed, when the loss or difference in the weight indicates the quantity of volatile ingredients in the coal. It is better to make three successive experiments on each kind of coal and to take the average, and these experiments ought to furnish results which do not differ one grain from each other. By these means the percentage of volatile matter and coke are obtained.

"Then, in order to ascertain the quantity of ash in the coke, this as taken from the crucible is placed in a muffle heated red hot, and through which a current of air passes slowly, when the carbon is consumed and carried away, leaving the incombustible residue or ash behind, which must be then weighed with care. If a small shallow vessel, made by turning up the sides of a piece of platinum foil, has been used to contain the coke, this is easily withdrawn at the end of the operation, and being transferred to the balance, we are enabled to weigh the whole without the risk of loss.

"The nature of the ash is of some consequence towards elucidating the history of the coal, for this purpose its colour must be noted, and a few simple tests applied to determine its chemical composition. If it is white, a portion may be treated at the blow pipe with a weak solution of the nitrate of cobalt, the ash being retained for a few seconds in the exterior or oxidizing flame. The presence of alumina renders the sample blue, magnesia gives a pale flesh-coloured tint, lime a greyish black, and oxide of iron and alumina combined a dirty green. When much alumina is supposed to exist, it becomes occasionally an interesting question to ascertain in a rough way its amount. This is easily done by fusing a given weight of the ash with twice its quantity of the bisulphate of potash, the heat being carried almost to redness, after which the whole is allowed to cool, and must then be boiled in water for a few minutes, and the solution filtered. This solution, on being set aside to cool, will furnish crystals of alum containing about 10 per cent of alumina.

"The operation may be conducted in a small Berlin-ware evaporating dish, and if 100 grains of ash and 200 of the bisulphate of potash have been used, the boiling water employed to dissolve the residue should not be less than four ounces, and this after filtration may be evaporated down to one ounce before it is put aside to crystallize. There is no danger of confounding together the alum and the bisulphide of potash, for the latter is an extremely soluble salt. All the ashes which contain silicate of alumina will thus furnish alum.

"It now remains to describe the means to be employed for ascertaining the quantity of sulphur in the coal and the quantity which passes off in the volatile products. Having reduced 100 grains of the coal to a fine powder this must be mixed with about 30 grains of pure carbonate of soda, also in fine powder. The mixture being now placed in a small iron ladle similar to those used in melting lead, is placed over a clean fire, so as to admit of the free ingress of air by which the bituminous and carbonaceous ingredients of the coal are burnt off gradually, whilst the sulphur combines with the metallic portion of the soda to form sulphuret of sodium. By retaining this latter a sufficient time over the fire it would ultimately be converted into sulphate of soda, but it is better to expedite this process, which is easily effected by sprinkling the mass whilst red hot with powdered nitrate of potash so long as any deflagration occurs. When this ceases altogether the heat should be raised for a few minutes, after which the ladle may be removed from the fire and suffered to cool. The soluble contents of the ladle are now to be extracted by boiling water and the solution filtered. The filtered liquor being then supersaturated with pure nitric acid, is next treated with an excess of a solution of nitrate of baryta, by which a precipitate is formed, and this precipitate carefully collected on a counterpoised filter, and well washed with boiling distilled water, may now be dried and weighed in the usual manner. Every 117 grains indicate 16 grains of sulphur, consequently we thus determine the amount in 100 grains of coal.

"To find the quantity of sulphur which passes off with the volatile matters, nothing more is necessary than to heat 100 grains of the coal in an iron crucible. The coke left after this process is then to be powdered, mixed with carbonate of soda, and treated exactly as described with respect to the coal itself, by which its contents of sulphur will also be determined, when it is needless to say that the difference represents the amount carried off in a volatile state.

"In some of the bituminous coals an appreciable quantity of carbonate of lime is found spreading itself in thin layers between the fissures of the coal. This substance has a remarkable effect in retaining the sulphur of the coal in the coke. It may, indeed, be looked upon as lime, and in this respect produces all the good effects which that substance is capable of performing in a purifier. This carbonate of lime, by the action of the impure coal gas, resolves itself into the sulphide of calcium, whilst its carbonic acid most probably becomes carbonic oxide. To the coke-maker, therefore, the presence of the carbonate of lime should be an objection, but the reverse as regards the gas-maker.

"In cannel coal the greater part of the sulphur seems to exist in what may be termed a volatile state of combination, or, at least in such form as enables it to pass off with the volatile products in much larger quantity than happens with bituminous coals. Now the effect of this volatile condition in determining the nature of the resulting impurities is a matter of some importance, for a careful examination of impure gas from cannel, and from bituminous coal, proves that the amount of bisulphide of carbon, as contrasted with that of sulphuretted hydrogen, is larger in the former than in the latter, though the reverse of this is the case when the total amount of impurity is under consideration. In other words, although generally a gas from cannel coal contains less sulphur than that from bituminous coal, yet the first contains more sulphide of carbon than the last, and hence after purification really possesses more sulphur in its composition. A short description of the mode in which the bisulphide of carbon is manufactured will explain the cause of this peculiarity. When free sulphur is passed in a volatile state over charcoal, or coke heated to a full cherry red, these substances combine together and produce bisulphide of carbon, exactly under the same circumstances as oxygen in contact with carbon produces carbonic oxide or carbonic acid. In this example the two simple substances are free or uncombined, and therefore at liberty to act upon each other at the lowest temperature capable of producing chemical union; hence this is the method daily adopted by those who make the bisulphide of carbon for sale. But it may also be made by distilling at a bright white heat a mixture of charcoal or coke and iron pyrites, and if this heat be maintained for a sufficient time, the iron of the pyrites will be found converted into carburet of iron, whilst the whole of the sulphur passes off in combination with carbon as bisulphide of carbon.

"In this way science is able to account for the seemingly absurd prolixity of the coke-makers' process, in which experience shows that the heat must be kept up for many hours, or even days, after the evolution of gaseous matter has ceased. What we have here to notice, however, is the fact that, whereas with free sulphur a red heat is sufficient for the production of bisulphide of carbon, in the case of iron pyrites a bright white and well-sustained temperature is requisite. Now it has been shown that in cannel coals there is every reason to believe that free sulphur exists; consequently, even at the heat needed for the production of gas such coals must give off during distillation not only sulphuretted hydrogen but also bisulphide of carbon almost from the beginning to the end of the process. But with bituminous coals our analysis shows that there is no free sulphur, for this element seems invariably united to iron as bisulphide of iron; therefore it is only towards the end of the charge, and when the heat verges on whiteness, that these coals afford bisulphide of carbon; moreover, by a well-regulated heat, such coals may be made to yield a gas quite free from bisulphide of carbon, which is not possible with most of the cannel coals.

"Again, as regards impurity, vast importance attaches to the amount of moisture contained in the coal, and which, since it is quite accidental, must not be looked upon as a constituent of the coal; but when a large quantity of this moist coal is thrown into a retort, the outer surface, after undergoing for some time the action of the fire, is converted into coke, and the bisulphide of iron into protosulphide of iron, over which latter the steam from the interior of the mass of coal passes, with of course the same result as if this protosulphide of iron were purposely subjected at a red heat to the action of the vapour of water: that is to say, the two compounds mutually decompose each other, and give rise to oxide of iron and sulphuretted hydrogen; so that by mismanagement of this kind, the whole of the sulphur contained in bituminous coals may be made to pass off with the gas, and thus double both the labour and expense of purification."

### HEAT AND FUEL.

Combustion, in the ordinary sense of the term, is produced by the combination of oxygen and carbon at a high temperature; as for example, wood, coal or similar substances, when exposed to the atmosphere and heated to a high degree, commence to give heat; and this continues until the whole of the mass is transformed into other products, which are nearly all gaseous, and dissipated in the surrounding atmosphere.

Combustion is also produced by the action of acids and other substances, and even the atmosphere on metals; thus the oxidation of iron by exposure to the atmosphere is a slow process of combustion. Again, animal life in respiring gives rise to another description of the process, and, briefly, in ordinary language, combustion is said to take place when the elements of a body unite with the oxygen of the atmosphere, and form new compounds.

When any solid substance capable of withstanding the action of the fire is heated to a certain point, it emits a degree of light in proportion to the temperature the body acquires. For instance, a piece of platinum or porcelain, when heated to a certain extent becomes perceptibly red, but as its temperature is augmented, the body attains a bright red or orange colour, and when a piece of lime is submitted to the influence of the oxyhydrogen blow-pipe, the light then becomes exceedingly intense. Under these conditions the platinum, porcelain, and lime, are in a state of incandescence, whilst the oxygen and hydrogen are in a state of combustion, and by their union producing water. But a substance may be in a high state of incandescence, and by an increase of heat combustion follows, as with a bar of iron heated to whiteness, when by a slight increase of heat the metal combines with the oxygen of the atmosphere, and the two form the oxide of iron.

In the destructive distillation of coal, however (at least during the early part of the operation), we have neither combustion nor incandescence, as the coal is distilled and the gas issues therefrom at the comparatively low temperature of about 160° Fahrenheit, identical in action with the water in an open boiler, or other vessel, which under ordinary conditions, on attaining the boiling point 212° any further heat communicated to the water passes off as steam. And in carbonization only after the greater portion of the gas is expelled, does the coke acquire the state of incandescence, when in the absence of oxygen this will retain its solid form, but on being exposed to the atmosphere, combustion takes place with the evolution of carbonic acid gas. Coal gas, on the instant of ignition, enters into combustion, and becoming incandescent, emits light.

Kahn, in his "Elements of Chemistry," says, "In combustion, as in all cases of chemical combination, no particle of matter becomes annihilated; it assumes new forms, in general gaseous and invisible to the eye of popular observation, but easily collected, weighed, and analyzed by the means that chemistry possesses. The solid coal, or wood, which burns to ashes, changes but in external aspect, mixing with a general mass of air under the form of carbonic acid and watery vapour, and these afterwards become the food of living plants, which in their turn are cut down or fossilized, and afford to succeeding ages the stores of warmth and light such as we now enjoy." To this may be added, that the gases arising from combustion also enter into the formation of those plants and cereals which aliment animal life generally, as well as to furnish the food and clothing of the human race.

The applications of heat are numerous and variable, such as for melting metals and glass, and other manufacturing purposes, or to render metals sufficiently malleable for working; or the generation of steam; for the destruction as ordinary distillation of substances; for culinary and other domestic uses, and in all its innumerable applications, artificial heat is destined exclusively for the use of man, for while to man fire is almost as essential as the water he drinks, or the air he breathes, yet in the absence of that element the rest of the animal creation would not be inconvenienced, nor is it essential to their welfare.

Coal, wood, and other ordinary combustible bodies are composed of carbon in a more or less fixed state, in combination with hydrogen, and in the process of combustion, these are converted into vapours called hydrocarbons, when according to the quantity and quality of these vapours and the means employed in consuming them, so are they resolved into flame, heat, and the corresponding gases, vapours and smoke. Thus the class of coal which is admirably suitable for gas-making, on account of the large quantity of volatile hydrocarbons it possesses, is on account of the difficulty experienced in consuming the whole of the vapours or smoke, ill adapted for the economical production of steam. For this reason cannel coal is never employed as fuel for furnaces. Unquestionably the best coal for steam purposes is that which contains the largest quantity of fixed carbon, and of course the minimum of volatile carbon, together with a minimum of ash and sulphur. Coal abounding in sulphur speedily destroys a boiler.

The quantity of volatile matter (that is, matter so volatile as to be driven off by destructive distillation) in different kinds of coal is variable, ranging from 68 per cent, as in Boghead Cannel to about 1 per cent in Anthracite. An average coal contains of volatile matter about 25 or 30 per cent of its total weight. The amount of ash is equally variable, but on the average this may be estimated at about 4 per cent and the sulphur at 1.2 per cent of the weight of ordinary good coal.

The following table is extracted to show different temperatures and their effects:—

#### DIFFERENT TEMPERATURES AND THEIR EFFECTS.

	Fahrenheit.		Fahrenheit.
The greatest cold that has been produced . . . . .	—135°	Phosphorus melts . . . . .	+ 108°
The solid compound of alcohol and carbonic acid melts	—121	Alcohol boils . . . . .	+ 174
Greatest cold by ordinary freezing mixtures . . . . .	— 91	Rose's metal melts . . . . .	+ 201
Temperature of the planetary spaces . . . . .	— 58	Newton's metal melts . . . . .	+ 211
Greatest cold observed in the Arctic regions . . . . .	— 60	Water boils . . . . .	+ 212
Sulphuric ether congeals . . . . .	— 47	Sulphur melts . . . . .	+ 218
Nitric acid congeals . . . . .	— 45	Mercury boils . . . . .	+ 662
Mercury congeals . . . . .	— 39	Antimony melts . . . . .	+ 810
Oil of vitriol freezes . . . . .	+ 1	Red heat . . . . .	+ 980
Oil of turpentine freezes . . . . .	+ 14	Heat of a common fire . . . . .	+ 1141
Wine freezes . . . . .	+ 20	Brass melts . . . . .	+ 1869
Blood freezes . . . . .	+ 25	Silver melts . . . . .	+ 1873
Ice melts . . . . .	+ 32	Copper melts . . . . .	+ 1996
Olive oil freezes . . . . .	+ 36	Gold melts . . . . .	+ 2200
Heat of human blood . . . . .	+ 98	Cast iron melts . . . . .	+ 2786

—Kahn's "Elements of Chemistry."

TABLE OF THE EXPANSION OF AIR BY HEAT.

Fahr.		Fahr.		Fahr.		Fahr.	
32°	1000	54°	1052	76°	1101	97°	1148
33	1002	55	1055	77	1104	98	1149
34	1004	56	1057	78	1106	99	1150
35	1007	57	1059	79	1108	100	1152
36	1009	58	1062	80	1110	110	1173
37	1012	59	1064	81	1112	120	1194
38	1015	60	1066	82	1114	130	1215
39	1018	61	1069	83	1116	140	1235
40	1021	62	1071	84	1118	150	1255
41	1023	63	1073	85	1121	160	1275
42	1025	64	1075	86	1123	170	1295
43	1027	65	1077	87	1125	180	1315
44	1030	66	1079	88	1128	190	1334
45	1032	67	1081	89	1130	200	1364
46	1034	68	1084	90	1132	210	1372
47	1036	69	1087	91	1134	212	1376
48	1038	70	1089	92	1136	302	1558
49	1040	71	1091	93	1138	392	1739
50	1043	72	1093	94	1140	482	1919
51	1045	73	1095	95	1142	572	2098
52	1047	74	1097	96	1144	680	2312
53	1050	75	1099				

—Bourne's "Treatise on the Steam Engine."

DIRECTIONS FOR TESTING GAS.

Ammonia can be detected in gas:—

- 1.—By its action upon the colour of turmeric paper, or reddened litmus paper.
- 2.—By its giving a white precipitate when the fumes of hydrochloric acid are brought in contact with the gas.
- 3.—By passing gas through hot lime, and then over test paper, or through acid.
- 4.—The quantity present may be estimated by passing the gas through acid, and determining the quantity which the acid has taken up by test alkali, or by chloride of platinum.

Ammonia has the property common to all alkalies of acting upon certain vegetable colours, and advantage is taken of this property to detect its presence. It changes the yellow colour of turmeric to a red brown, and of reddened litmus paper to a full blue. These changes of colour are temporary only, for owing to the volatility of ammonia, it flies off and leaves the reddened litmus red, and the turmeric yellow, as they were before they were affected by the ammonia. The fixed alkalies, as they are called, potash and soda, do not fly off, but change the colour of the tests permanently.

To apply these tests, the paper is slightly damped, so that the ammonia may be absorbed and be brought thoroughly into contact with the vegetable colouring matter, and held within about a quarter of an inch of a gas jet, such as a fish-tail burner, from which gas is issuing in full stream. Generally the turmeric paper becomes brown, and the red litmus paper blue, in less than a quarter of a minute, and thus the presence of ammonia is shown. If the test paper held thus be not discoloured, it should be damped and put into a glass tube of about three-eighths of an inch in diameter, through which a full stream of the gas under examination should pass for about half a minute, when, if the colour of the test is not changed, the gas certainly does not contain any free ammonia."

Ammonia is also detected by dipping a glass rod or a feather into hydrochloric acid, and holding it in a stream of the gas. when, if the impurities be present, a white cloud of sal-ammoniac will be formed. Or its presence may be shown in gas which will not affect test paper, by passing the gas through a tube of hot lime, and testing it with turmeric paper after its exit from the tube.

The author of "The Analysis of Gas" strongly recommends all manipulators to prepare their own test papers, and also to be assured from time to time of their efficiency.

**TO MAKE TURMERIC PAPER.**—Pour six ounces of spirit of wine upon an ounce of turmeric powder in a clean stoppered bottle. Shake it well once daily for three or four days, and let it stand till the powder has settled to the bottom, and left a clear fluid above it. Pour this fluid into a clean plate, into which dip pieces of white filtering paper, and when they are thoroughly soaked, dry them upon strings. As soon as dry, cut them into slips, and keep them in a well-corked bottle in a drawer, or other place, away from the light.

**TO MAKE BLUE LITMUS PAPER.**—To an ounce of pulverized litmus add six ounces of cold water; shake well, and allow it to digest. Filter, and saturate filtering paper, which dry and cut in slips as already described. The presence of an acid is indicated by this test turning red.

**TO MAKE RED LITMUS PAPER.**—Take a portion of the blue solution of litmus, and add as much very dilute sulphuric acid as will leave the paper distinctly, but not strongly red when dry. The acid must be added by a single drop at a time. Prepare the test paper in the manner already mentioned. These test papers must be kept in a well-closed bottle in the dark, so that they are protected from both air and light. All these test papers are slightly moistened on being employed.

**TESTING GAS FOR CARBONIC ACID.**—The presence of carbonic acid in gas is determined by causing the gas to bubble through lime water. If carbonic acid be present, the water will become milky; the same effect is produced by blowing gently into the liquid arising from the carbonic acid given off by the lungs. The quantity of carbonic acid is determined by receiving the gas in a graduated tube over mercury, and passing up a ball of solid potash, or a few drops of a strong solution of potash. The carbonic acid is absorbed by the alkali, and the amount of condensation gives the per centage of the compounds present.

**TO PREPARE LIME WATER.**—To a quart of water add three or four ounces of quick-lime; give it time to dissolve, after which decant the clear fluid, which is as transparent as pure water.

NOTES.

Compressed air, when suddenly reduced to one-fifth its original bulk, inflames tinder.

The blue flame observed sometimes at the top of the funnels of steam vessels does not extend down the funnel, and is caused by the combustion of carbonic oxide, which can only burn by the supply of fresh air at the top of the funnel, the mixture igniting at a comparatively low temperature. It is impossible for a flame to exist throughout a tube of ordinary length.

Charcoal ignites at about 460° Fahr.

Mr. J. W. Adams, of New York, states that by means of Mr. Stevens's apparatus for burning petroleum in combination with jets of steam, 29·33 lbs of water at 60° Fahr. are converted into steam by one pound of oil.

A mode of utilizing fuel was patented some time ago, by which coal, and coke, peat, and other combustible material, is introduced into the furnaces in the state of powder or dust, instead of solid lumps or blocks. This carbon dust or powder is introduced by means of a blast of air or steam or both combined, and produced by a fan or blowing machine, or by a steam jet direct from the boiler. The air and steam in connection with this carbon dust or powder is heated or superheated, as usually practised.

Lignites are all inferior to bituminous coals as heating agents, on account of their possessing more oxygen, and consequently, less carbon than coal.

The hydraulic coal-cutting machine, with a supply of 30 gallons of water per minute, will do as much work as 20 men, making nearly 30 per cent less slack.

The bogs of Great Britain and Ireland cover an area exceeding 5,000,000 acres, the average depth of which may be taken at 20 feet.

COMPARATIVE POWER OF SUBSTANCES FOR CONDUCTING HEAT.

Gold . . . . .	1000	Tin . . . . .	303·9
Silver . . . . .	973·	Lead . . . . .	179·6
Platina . . . . .	981·	Marble . . . . .	23·6
Copper . . . . .	898·2	Porcelain . . . . .	12·2
Iron . . . . .	374·3	Firebricks . . . . .	11·4
Zinc . . . . .	363·		

Black being a colour that absorbs nearly all the sun's rays, any object painted black becomes much hotter when it is exposed to the sun than if it had been painted white or some other colour.

NON-CONDUCTING SUBSTANCES ARRANGED IN THE ORDER IN WHICH THEY RESIST THE PASSAGE OF THE HEAT, THE BEST NON-CONDUCTING SUBSTANCES BEING PLACED FIRST, AND REFERRED TO THAT OF SLATE, EQUAL TO 100.

Plaster and Sand . . . . .	18·70	Stock brick . . . . .	60·14
Plaster of Paris . . . . .	20·26	Bath stone . . . . .	61·08
Roman Cement . . . . .	20·88	Fire brick . . . . .	61·70
Beech wood . . . . .	22·44	Painswick stone . . . . .	71·36
Lath and Plaster . . . . .	25·55	Portland stone . . . . .	75·10
Fir wood . . . . .	27·61	Bolsover stone . . . . .	76·35
Oak wood . . . . .	33·66	Norfal stone . . . . .	95·36
Asphalte . . . . .	45·19	Slate . . . . .	100·
Chalk, soft . . . . .	56·38	Yorkshire Flag . . . . .	110·94
Marble . . . . .	58·27	Lead . . . . .	521·34

PROPORTIONATE POWER OF VARIOUS SUBSTANCES FOR RADIATING HEAT.

Lamp black . . . . .	100	Isinglass . . . . .	80
Water . . . . .	100	Plumbago . . . . .	75
Writing paper . . . . .	98	Tarnished lead . . . . .	45
Resin . . . . .	96	Mercury . . . . .	20
Sealing wax . . . . .	95	Clean lead . . . . .	19
Crown glass . . . . .	90	Iron polished . . . . .	15
China ink . . . . .	88	Tin plate . . . . .	12
Ice . . . . .	85	Gold, Silver, and Copper . . . . .	12

The nature of the substance is not the only circumstance that influences radiation. In general, the more smooth and polished the surface the more feeble is its radiating power. If the surface be roughened with a file or otherwise, its radiation is increased. It also appears that the radiation occurs not only from the superficial particles, but also from those immediately beneath them. With one coating of jelly, it was found that the radiation was 38°, whilst a film of the same substance four times thicker produced a depression of 54°. When the thickness of the coating amounted to  $\frac{1}{1800}$  part of an inch, the radiation became diminished. If the same radiating surface be presented to different mirrors we shall discover the difference in the reflective powers.

PROPORTIONATE REFLECTIVE POWER OF VARIOUS SUBSTANCES.

Brass . . . . .	100	Lead . . . . .	60
Silver . . . . .	90	Tinfoil softened with Mercury . . . . .	10
Tinfoil . . . . .	85	Glass . . . . .	10
Block tin . . . . .	80	Glass coated with Wax or Oil . . . . .	5
Steel . . . . .	70		

If we compare these two tables, we shall find that the best radiators are the worst reflectors, and *vice versa*. It may easily be inferred that those bodies that radiate most caloric when heated above the temperature of the surrounding medium, will also absorb most rapidly when exposed to a temperature superior to their own. In general, those bodies intercept heat most effectually which are the worst radiators.

EXPANSION OF LIQUIDS IN BULK FROM 32° TO 212° FAHRENHEIT.

Alcohol . . . . .	$\frac{1}{8}$	Muriatic acid . . . . .	$\frac{1}{7}$
Nitric acid . . . . .	$\frac{1}{8}$	Water saturated with salt . . . . .	$\frac{1}{20}$
Fixed oils . . . . .	$\frac{1}{12}$	Water . . . . .	$\frac{1}{11}$
Oil of Turpentine . . . . .	$\frac{1}{12}$	Mercury . . . . .	$\frac{1}{12}$
Sulphuric ether . . . . .	$\frac{1}{12}$	Apparent expansion of Mercury in glass . . . . .	$\frac{1}{12}$
Sulphuric acid . . . . .	$\frac{1}{12}$		

EXPANSION OF AIR.

Air at 60° has its volume increased	Air at 60° has its volume increased	Air at 60° has its volume increased
Double at . . . . . 568°	Fivefold at . . . . . 2092°	Eightfold at . . . . . 3616°
Threefold „ . . . . . 1076	Sixfold „ . . . . . 2600	Ninefold „ . . . . . 4124
Fourfold „ . . . . . 1584	Sevenfold „ . . . . . 3108	Tenfold „ . . . . . 4632

**[B]**  
**RETORTS, BENCH FITTINGS, TOOLS,**  
*And Implements for the Retort House.*

GEORGE BOWER manufactures and supplies every description of article used in the distillation of coal, wood, or peat, for Gas purposes, of the best quality of material, form, and workmanship.

Each setting includes Retorts, mouth-pieces, furnace-doors, evaporating pan, damper, pilasters, tie-bolts, sight boxes, ascension, N and dip-pipes, hydraulic main and crutches, cross-bars, and T screws, bolts, fire bricks, lumps and clay.

FIG. 1.

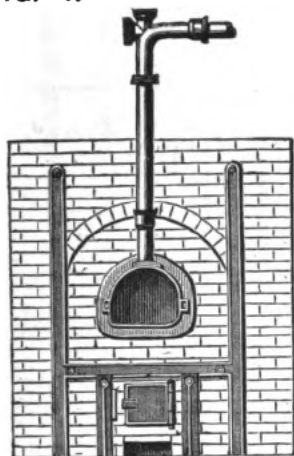

SETTING OF 1 IRON D RETORT.

With Retort 5 feet long by 14 by 10, price	£	s.	d.
"    6    "    "    14    "    12    "			
"    7    "    "    14    "    12    "			

The accompanying figures represent the elevations of various settings of iron retorts. Fig. 1 is a setting of 1 Iron D Retort. Fig. 2 is a setting of 2 Retorts, one of which is fixed over the other, as often practised, and in fig. 3 they are set side by side, the oven being sufficiently large to contain a third, as shewn in dotted lines. By this arrangement an additional Retort can be fixed at a future period, when the business increases, and the trouble and expense of rebuilding the oven be avoided. Fig. 4 and 5 are elevations of settings of 3 and 5 Iron Retorts respectively.

FIG. 2.

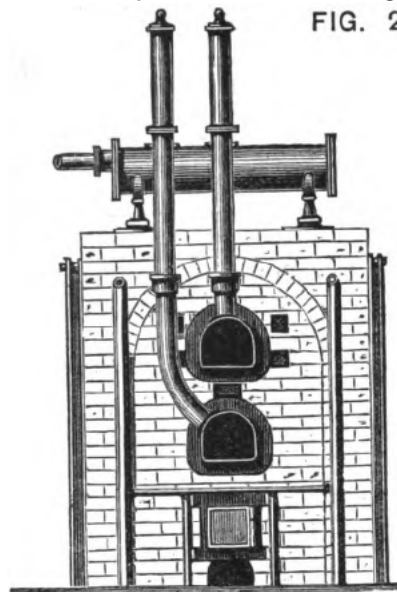

SETTING OF 2 IRON D RETORTS.

With Retorts 6 feet long by 14 by 12, price	£	s.	d.
"    7    "    "    14    "    12    "			

FIG. 3.

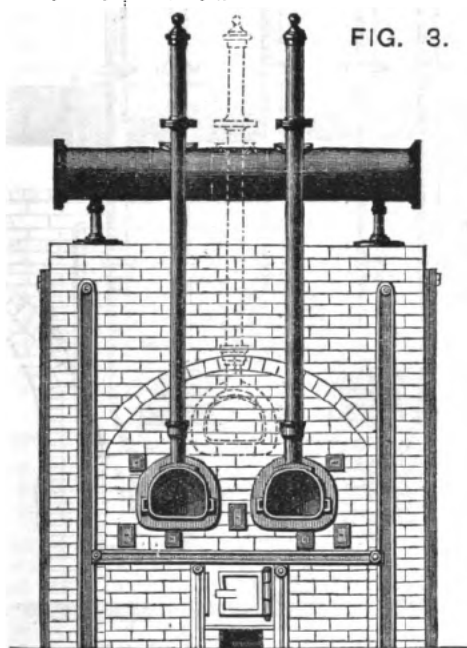

SETTING OF 2 IRON D RETORTS.

With Retorts 6 feet long by 14 by 12, price	£	s.	d.
"    7    "    "    14    "    12    "			

FIG. 4.

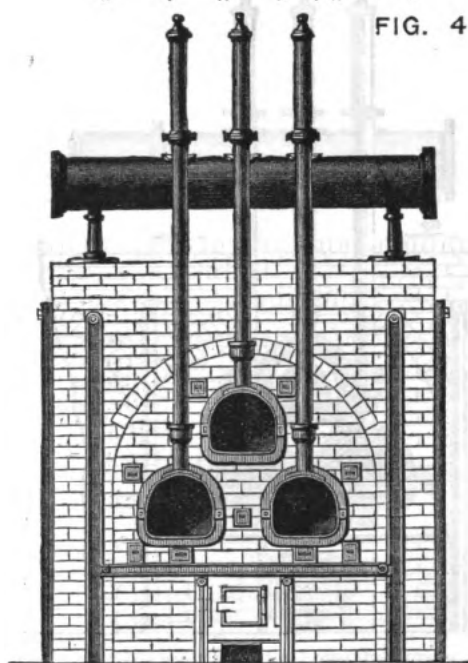

SETTING OF 3 IRON RETORTS.

With Retorts 6 feet long by 14 by 12, price	£	s.	d.
"    7    "    "    14    "    12    "			
"    7    "    "    16    "    15    "			
"    8    "    "    16    "    15    "			

THE BOARD OF DIRECTORS OF THE COMPANY HEREBY RESOLVES THAT THE ACCOUNTS OF THE COMPANY FOR THE YEAR ENDED 31ST MARCH 1965 BE AS FOLLOWS:

STATEMENT OF PROFIT AND LOSS

Revenue account for the year ended 31st March 1965, as shown in the Statement of Profit and Loss, is as follows:

Revenue account for the year ended 31st March 1965, as shown in the Statement of Profit and Loss, is as follows:

Particulars	£				Total	Notes
	1965	1964	1963	1962		
Revenue	100	100	100	100	100	
Cost of sales	(80)	(80)	(80)	(80)	(80)	
Gross profit	20	20	20	20	20	
Operating expenses	(15)	(15)	(15)	(15)	(15)	
Operating profit	5	5	5	5	5	
Finance income	1	1	1	1	1	
Finance charges	(1)	(1)	(1)	(1)	(1)	
Profit before tax	4	4	4	4	4	
Income tax	(1)	(1)	(1)	(1)	(1)	
Profit after tax	3	3	3	3	3	
Dividend paid	(3)	(3)	(3)	(3)	(3)	
Profit retained in the year	0	0	0	0	0	



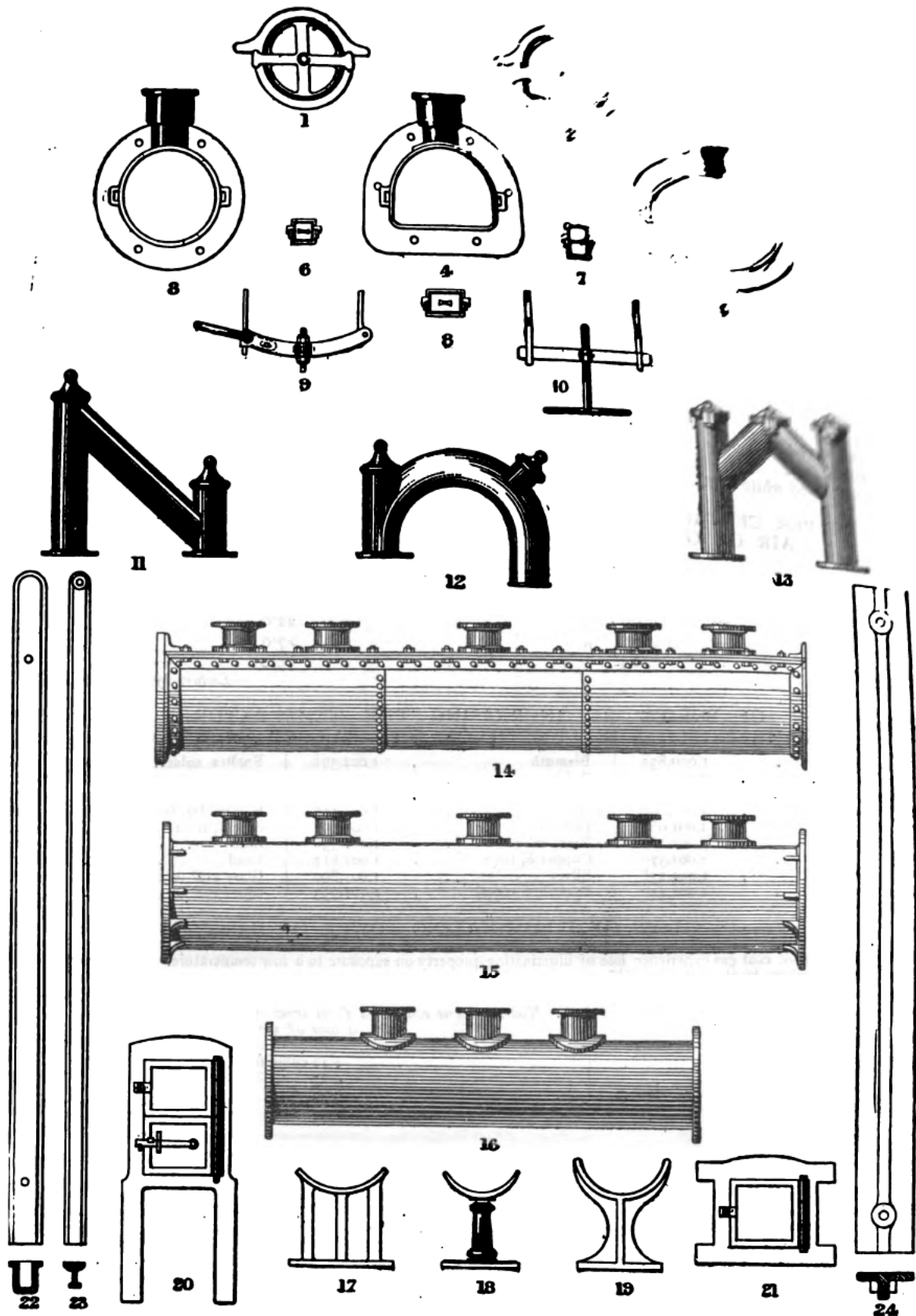

## THE FORMATION OF COAL.

The vegetable origin of coal is too well established now to be questioned, but the difference between the present rate of growth and that existing at an earlier period of the earth's history, is too startling to be overlooked. It is, however, explained by some writers that, at the former period, the earth had not cooled down to its present state, and that this, combined with a warm, humid atmosphere, and assisted by the sun's rays, produced a more than tropical vegetation. The formation of coal is generally ascribed to the agency of drift, or the accumulation of vast bodies of trees and plants at the mouths of large rivers and in estuaries, and which is continually going on.

An extract from Dr. Lardner's "Pre-Adamite Earth" will tend considerably to the elucidation of this subject:—

"At length, "he says," the temperature being reduced to a point compatible with organised life, creative power began to be manifested. The earth was peopled with animals and clothed with vegetation, but these animals and this vegetation differed altogether from those which now animate and cover the globe. They were, however, adapted by Divine wisdom to the then condition of the earth, the temperature being not only greater than any which prevails at present, but also uniform in all latitudes.

"After this, a like succession of convulsions took place, long intervals of time intervening, by each of which the relative levels of the land were changed, and consequently the distribution of the waters of the ocean completely altered; such changes implied universal inundations, which involved the destruction of all animated nature, animal as well as vegetable. In short, a succession of deluges must have attended such convulsions, each deluge destroying all the tribes of animals and plants which existed on the globe at the time of the catastrophe.

"After each of these convulsions, the waters at first turbid, and holding in suspension great quantities of matter washed away and eroded from the former land, as well as enormous quantities of the remains of the animals and plants previously existing, would, after a time, become tranquil, and then a process of vast importance to the preservation of the history of the globe would take place. The organic remains of animals and plants suspended in the waters would be deposited at the bottom of the ocean, and over them would subside also the solid matter sustained in a state of comminution in the waters. The remains would thus be buried in strata sensibly horizontal, and being covered up by the earthy and mineral matter which would subside from the waters, they would be protected from the destructive action of air and water thereafter, and would thus be preserved to future generations as records of the past history of the earth.

"In the interval of tranquillity following each such deluge creative power was again brought into operation, and the earth was re-peopled with animated creatures, and re-clothed with vegetation: but in all cases the animals and plants composing the new kingdoms of nature, though agreeing with those recently destroyed in their classes and generic characters, differed from them altogether in their species. In short, a new kingdom of nature was produced, but constructed upon the same general principles.

"By researches made in the crust of the earth, and careful analyses of the constitution of its strata, and of the animal remains contained in them, geologists have ascertained, that *subsequently* to the first appearance of the forms of animal life, which, as has been stated, took place after the fourth great convulsion of the globe, there were at least *twenty-eight successive convulsions* of a like nature, each of which was attended with the complete destruction of the animals and plants which existed upon the globe, their remains being buried, in the manner already stated, under the sedimentary deposits made by the new oceans which followed the crisis.

"The actual occurrence of these several convulsions, and of the existence of the successive animal and vegetable kingdoms, differing one from another in the species of which they were constituted, has been proved by geologists by two species of evidence, one depending on the condition of the stratification, by which it has been shown that many of these catastrophes were attended with the elevation of systems of mountains which still exist upon the surface of the earth; while others, though not indicated by mountain ranges, are rendered evident by certain discordances and disturbances in the state of the strata."

## THE OXY-HYDROGEN LIGHT.

This was first introduced to public notice by Lieutenant Drummond. It consists of a jet of oxygen and hydrogen gases, or of alcohol and oxygen, burning so as to ignite a piece of lime or magnesia; and the high temperature which is thus produced, renders the earthy body so incandescent as to be intensely luminous. The apparatus which is employed for the production of this light has, at various times, undergone considerable alteration and improvement. Originally, the mixed gases, consisting of two parts by measure of hydrogen and one of oxygen, were condensed by means of a syringe, worked at great pressure, into a square metal box, from which there issued a long jet of very small bore; this jet passed through a thick oak partition, in order that the operators might be protected from the danger which was incidental to the bursting of the metal box from explosion. This was the form of apparatus originally contrived by Clarke and Newman. After this the safety-jets of Gurney, Hemming, and others, were adopted; and at the present time it is customary to burn the mixed gases by means of the latter, or else to deliver the gases separately into a double jet or nozzle, where they mix immediately before they are consumed. Both of these plans are very manageable, though the latter is thought to be less susceptible to the risk of explosion than the former.

The hydrogen gas is obtained by acting on zinc with diluted sulphuric acid (one of acid to ten or twelve of water), and the oxygen, by heating a pulverulent mixture of four parts of chlorate of potash, and one of peroxide of manganese in a glass retort. In each case the gas is to be collected in a gas-holder, or else in bladders fixed to receivers over a pneumatic trough.

When the mixed gases are burnt, the flame is impinged upon a small cylinder of lime or magnesia, which has a rotary motion, in order to expose a fresh surface continually to the action of the flame.

Another mode of obtaining this light, is to throw a jet of oxygen into a flame of spirit of wine or ether, or to mix the oxygen with coal-gas instead of with hydrogen.

The light which is obtained by either of these plans is very intense. When concentrated by means of a concave mirror, it is distinctly visible at a distance of sixty-five miles, and it is calculated, that the mixture of oxygen and coal gas, when compared with the light of a wax candle, is equal to twenty-nine of such candles; that of alcohol and oxygen to sixty-nine; that of ether and oxygen to seventy six; and that of hydrogen and oxygen to one hundred and fifty-three. In consequence of the great intensity of the oxy-hydrogen light, it is generally used for the phantasmagoria, the dissolving views, the solar microscope, and for theatrical illuminations and experiments in optics: besides which, it has been recommended for light-houses and signal lights. The light differs from all others in the circumstance of its being exceedingly white, and therefore well suited for the display of bright and delicate colours. With this light the various shades and tints of a picture or dress are as plainly discernible as they are by the diffused light of day.

## COMPARATIVE ILLUMINATING POWER OF THE GAS SUPPLIED TO VARIOUS TOWNS AND CITIES.

EUROPEAN CAPITALS.			BRITISH CITIES AND TOWNS—continued.		
Name	Authority	Illuminating power in Standard sperm candles	Name	Authority	Illuminating power in Standard sperm candles.
Berlin	Hofmann	15.5	Glasgow	Penny	28.0
Paris	Fremy	12.3	Aberdeen	"	35.0
London	Letheby	12.1	Greenock	"	28.5
Vienna	Redlenbacher	9.0	Hawick	"	30.0
Edinburgh	Penny	28.0	Inverness	"	25.0
			Paisley	"	30.3
BRITISH CITIES AND TOWNS.			Carlisle	"	16.0
Manchester	Leigh	22.0	Birmingham	Frankland	15.0
Liverpool	King	22.0			

[C]

# CONDENSERS,

MANUFACTURED AND SUPPLIED BY

## GEORGE BOWER,

*Gas and Water Engineer and Contractor, St. Neots, Hunts.*

The object of the Condenser is to reduce the vapours intermixed with the gas, when issuing from the hydraulic main, into ammoniacal liquor and tar, by which process the latter is prevented from passing forward to the other apparatus, and impairing their efficiency, and the two residuals are retained. The condenser also serves to reduce the temperature of the gas to the degree most favourable for depositing its ammonia in the washer or scrubber. Lastly, the tar in the condenser eliminates a portion of the sulphuretted hydrogen, carbonic acid, and bisulphide of carbon, and for these reasons the apparatus in question may be regarded as a part of the purifiers.

Condensers are constructed of various forms, and usually consist of a series of ordinary pipes connected together, either vertically or horizontally, by breeches pieces, but, whichever plan may be adopted, each pipe is communicated at the end with that next to it, and in such a manner that the gas passes through the whole length of all the pipes from the inlet to the outlet. For the purpose of cleaning the condenser, whenever it may be desirable, the breeches pipes are provided with suitable caps.

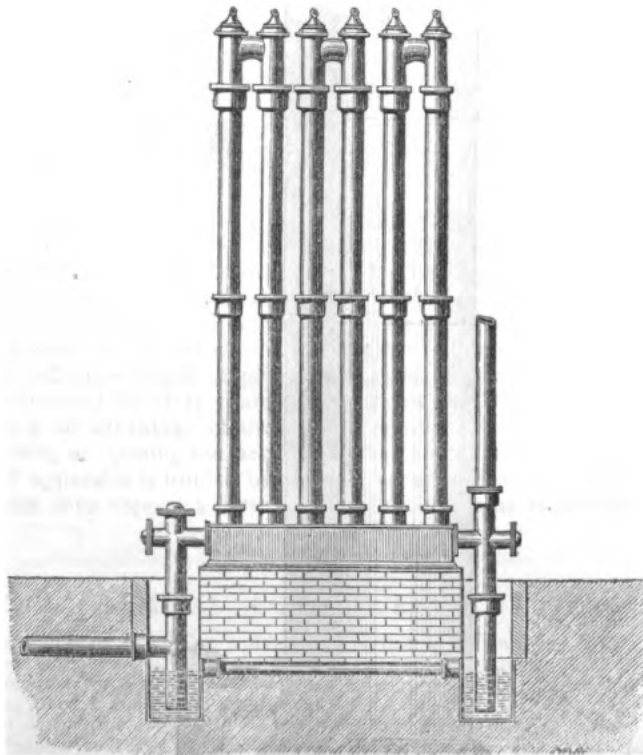

The vertical condenser represented above is composed of a bottom box of cast-iron, furnished at the top with the necessary number of sockets for the respective stand pipes, which are connected to one another in pairs with breeches pieces and cleaning caps. The bottom box is divided into partitions arranged in such a manner that, when the vessel is charged with the necessary quantity of water or tar, the gas shall pass through the whole range of pipes in succession. The box is also fitted with clearing doors, dip pipes and dip cisterns, with bolts, nuts, and all complete, ready for fixing. In condensers having more than 6 pipes, the pipes are arranged in two rows.

CAST IRON VERTICAL PIPE CONDENSERS.

Price—£ s. d.				Price—£ s. d.			
2-in. Condenser, formed of 10 pipes 7-ft. high				5-in. Condenser, formed of 10 pipes 20 ft. high			
3 " " "	10	"	11 "	6 " " "	10	"	20 "
3 " " "	12	"	11 "	8 " " "	6	"	20 "
4 " " "	6	"	11 "	8 " " "	12	"	20 "
4 " " "	14	"	11 "	8 " " "	18	"	20 "
5 " " "	6	"	20 "				

GEORGE BOWER, ST. NEOTS, HUNTINGDONSHIRE.

Mr. J. W. Adams, of New York, states that by means of Mr. Stevens's apparatus for burning petroleum in combination with jets of steam, 29 3/3 lbs of water at 60° Fahr. are converted into steam by one pound of oil.

A mode of utilizing fuel was patented some time ago, by which coal, and coke, peat, and other combustible material, is introduced into the furnaces in the state of powder or dust, instead of solid lumps or blocks. This carbon dust or powder is introduced by means of a blast of air or steam or both combined, and produced by a fan or blowing machine, or by a steam jet direct from the boiler. The air and steam in connection with this carbon dust or powder is heated or superheated, as usually practised.

Lignites are all inferior to bituminous coals as heating agents, on account of their possessing more oxygen, and consequently, less carbon than coal.

The hydraulic coal-cutting machine, with a supply of 30 gallons of water per minute, will do as much work as 20 men, making nearly 30 per cent less slack.

The bogs of Great Britain and Ireland cover an area exceeding 5,000,000 acres, the average depth of which may be taken at 20 feet.

COMPARATIVE POWER OF SUBSTANCES FOR CONDUCTING HEAT.

Gold . . . . .	1000	Tin . . . . .	303.9
Silver . . . . .	973	Lead . . . . .	179.6
Platina . . . . .	981	Marble . . . . .	23.6
Copper . . . . .	898.2	Porcelain . . . . .	12.2
Iron . . . . .	374.3	Firebricks . . . . .	11.4
Zinc . . . . .	363		

Black being a colour that absorbs nearly all the sun's rays, any object painted black becomes much hotter when it is exposed to the sun than if it had been painted white or some other colour.

NON-CONDUCTING SUBSTANCES ARRANGED IN THE ORDER IN WHICH THEY RESIST THE PASSAGE OF THE HEAT, THE BEST NON-CONDUCTING SUBSTANCES BEING PLACED FIRST, AND REFERRED TO THAT OF SLATE, EQUAL TO 100.

Plaster and Sand . . . . .	18.70	Stock brick . . . . .	60.14
Plaster of Paris . . . . .	20.26	Bath stone . . . . .	61.08
Roman Cement . . . . .	20.88	Fire brick . . . . .	61.70
Beech wood . . . . .	22.44	Painswick stone . . . . .	71.36
Lath and Plaster . . . . .	25.55	Portland stone . . . . .	75.10
Fir wood . . . . .	27.61	Bolsover stone . . . . .	76.35
Oak wood . . . . .	33.66	Norfal stone . . . . .	95.36
Asphalte . . . . .	45.19	Slate . . . . .	100
Chalk, soft . . . . .	56.38	Yorkshire Flag . . . . .	110.94
Marble . . . . .	58.27	Lead . . . . .	521.34

PROPORTIONATE POWER OF VARIOUS SUBSTANCES FOR RADIATING HEAT.

Lamp black . . . . .	100	Isinglass . . . . .	80
Water . . . . .	100	Plumbago . . . . .	75
Writing paper . . . . .	98	Tarnished lead . . . . .	45
Resin . . . . .	96	Mercury . . . . .	20
Sealing wax . . . . .	95	Clean lead . . . . .	19
Crown glass . . . . .	90	Iron polished . . . . .	15
China ink . . . . .	88	Tin plate . . . . .	12
Ice . . . . .	85	Gold, Silver, and Copper . . . . .	12

The nature of the substance is not the only circumstance that influences radiation. In general, the more smooth and polished the surface the more feeble is its radiating power. If the surface be roughened with a file or otherwise, its radiation is increased. It also appears that the radiation occurs not only from the superficial particles, but also from those immediately beneath them. With one coating of jelly, it was found that the radiation was 38, whilst a film of the same substance four times thicker produced a depression of 54°. When the thickness of the coating amounted to 1/100th part of an inch, the radiation became diminished. If the same radiating surface be presented to different mirrors we shall discover the difference in the reflective powers.

PROPORTIONATE REFLECTIVE POWER OF VARIOUS SUBSTANCES.

Brass . . . . .	100	Lead . . . . .	60
Silver . . . . .	90	Tinfoil softened with Mercury . . . . .	10
Tinfoil . . . . .	85	Glass . . . . .	10
Block tin . . . . .	80	Glass coated with Wax or Oil . . . . .	5
Steel . . . . .	70		

If we compare these two tables, we shall find that the best radiators are the worst reflectors, and vice versa. It may easily be inferred that those bodies that radiate most caloric when heated above the temperature of the surrounding medium, will also absorb most rapidly when exposed to a temperature superior to their own. In general, those bodies intercept heat most effectually which are the worst radiators.

EXPANSION OF LIQUIDS IN BULK FROM 32° TO 212° FAHRENHEIT.

Alcohol . . . . .	1/2	Muriatic acid . . . . .	1/2
Nitric acid . . . . .	1/2	Water saturated with salt . . . . .	1/2
Fixed oils . . . . .	1/2	Water . . . . .	1/2
Oil of Turpentine . . . . .	1/2	Mercury . . . . .	1/2
Sulphuric ether . . . . .	1/2	Apparent expansion of Mercury in glass . . . . .	1/2
Sulphuric acid . . . . .	1/2		

EXPANSION OF AIR.

Air at 60° has its volume increased	Air at 60° has its volume increased	Air at 60° has its volume increased
Double at . . . . . 568°	Fivefold at . . . . . 2092°	Eightfold at . . . . . 3616°
Threefold " . . . . . 1076	Sixfold " . . . . . 2600	Ninefold " . . . . . 4124
Fourfold " . . . . . 1584	Sevenfold " . . . . . 3108	Tenfold " . . . . . 4632

[B] RETORTS, BENCH FITTINGS, TOOLS,  
*And Implements for the Retort House.*

GEORGE BOWER manufactures and supplies every description of article used in the distillation of coal, wood, or peat, for Gas purposes, of the best quality of material, form, and workmanship.

Each setting includes Retorts, mouth-pieces, furnace-doors, evaporating pan, damper, pilasters, tie-bolts, sight boxes, ascension, N and dip-pipes, hydraulic main and crutches, cross-bars, and T screws, bolts, fire bricks, lumps and clay.

FIG. 1.

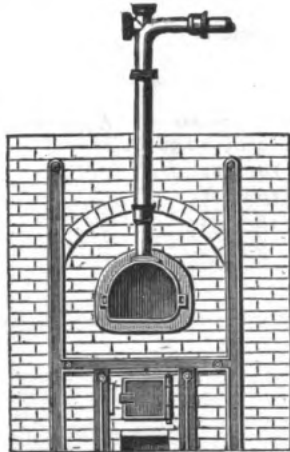

SETTING OF 1 IRON D RETORT.

	With Retort	5 feet long	by 14	by 10,	price	£	s.	d.
			inches	inches				
"	6	"	"	14	"	12	"	"
"	7	"	"	14	"	12	"	"

The accompanying figures represent the elevations of various settings of iron retorts. Fig. 1 is a setting of 1 Iron D Retort. Fig. 2 is a setting of 2 Retorts, one of which is fixed over the other, as often practised, and in fig. 3 they are set side by side, the oven being sufficiently large to contain a third, as shewn in dotted lines. By this arrangement an additional Retort can be fixed at a future period, when the business increases, and the trouble and expense of rebuilding the oven be avoided. Fig. 4 and 5 are elevations of settings of 3 and 5 Iron Retorts respectively.

FIG. 2.

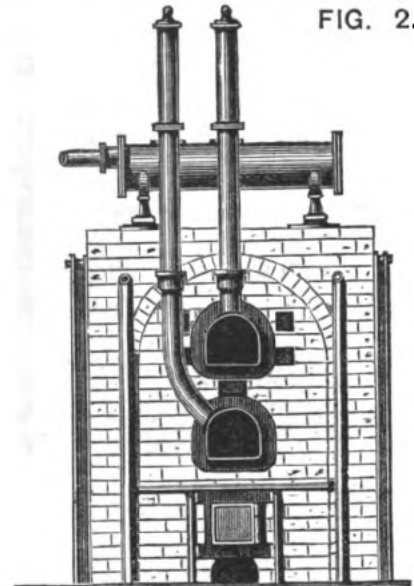

SETTING OF 2 IRON D RETORTS.

	With Retorts	6 feet long	by 14	by 12,	price	£	s.	d.
			inches	inches				
"	7	"	"	14	"	12	"	"

FIG. 3.

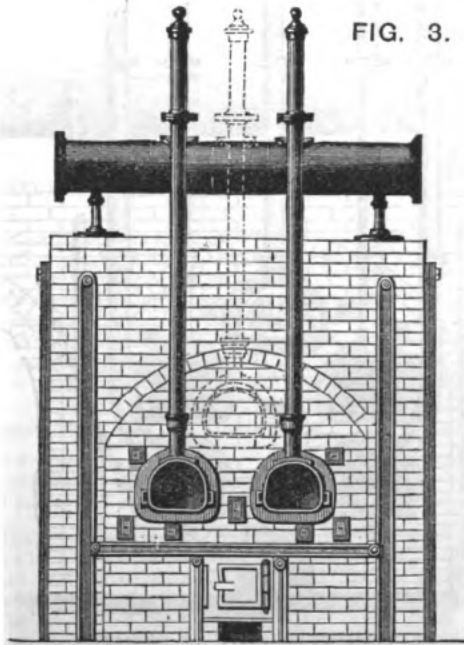

SETTING OF 2 IRON D RETORTS.

	With Retorts	6 feet long	by 14	by 12,	price	£	s.	d.
			inches	inches				
"	7	"	"	14	"	12	"	"

FIG. 4.

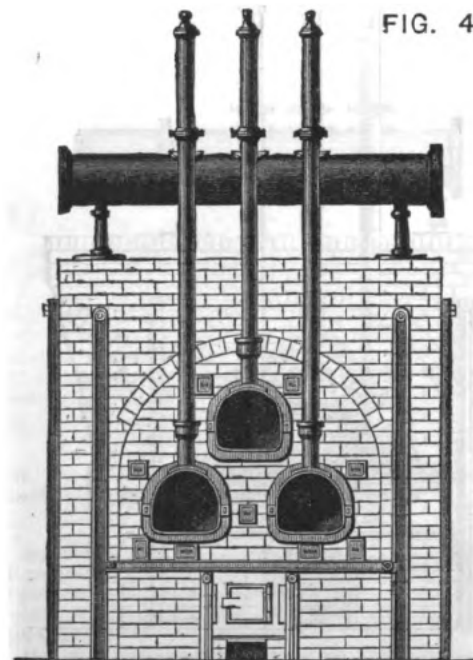

SETTING OF 3 IRON RETORTS.

	With Retorts	6 feet long	by 14	by 12,	price	£	s.	d.
			inches	inches				
"	7	"	"	14	"	12	"	"
"	7	"	"	16	"	15	"	"
"	8	"	"	16	"	15	"	"

An excellent system of has been extensively adopted in places requiring a limited supply is embedded in its setting and framework. The brickwork at thick, and is arched over. The fitted with furnace door and sight plates are latticed, and the whole very compact, strong, and useful The price of the Apparatus

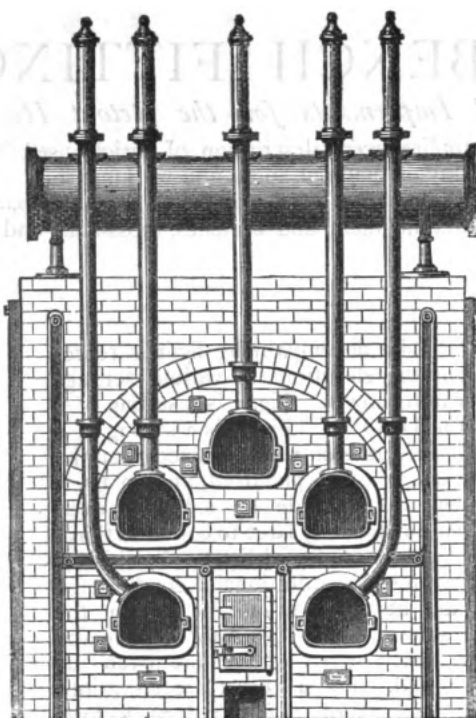

setting a single retort, and which manufactories, schools, and other of gas, consists of a retort which enclosed by a cast-iron case or the thinnest part is 9 inches front part of this framework is boxes, and contains an opening mitted into its place. The side is bolted together, forming a setting. complete is £

With Retorts 6 feet long

"	7	"
"	7	"
"	8	"

inches	inches	£	s.	d.
by 14	by 12	price		
" 14	" 12	"		
" 16	" 15	"		
" 16	" 15	"		

SETTING OF 5 IRON D RETORTS.

### Clay Retorts.

The following engravings represent elevations of different settings of Clay Retorts. (For Remarks thereon see page 18.)

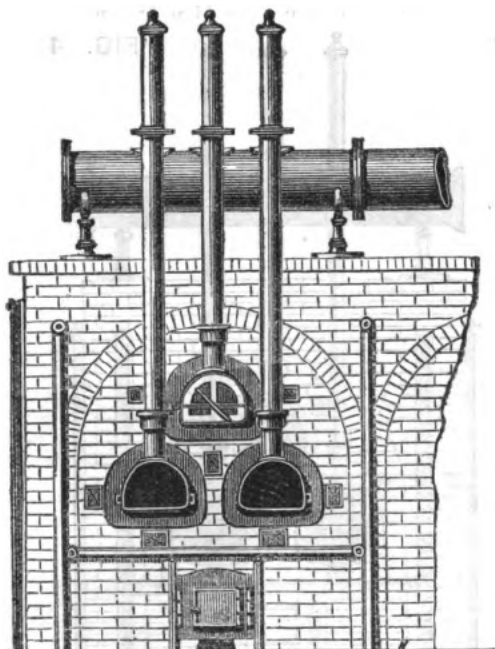

SETTING OF 3 CLAY D RETORTS.

With Retorts 8 feet long by 17 by 13, price  
 For every 6 inches less or more in length of retort, deduct or add, per retort, s. d.

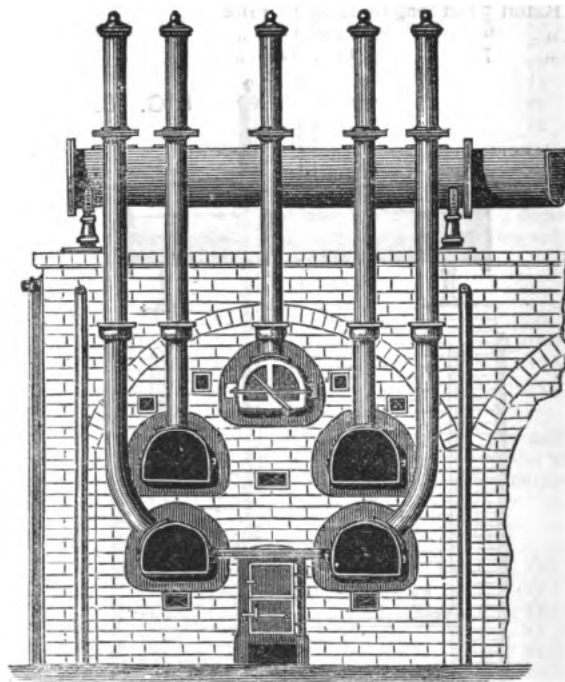

SETTING OF 5 CLAY D RETORTS.

With Retorts 8 feet long by 17 by 13, price  
 For every 6 inches less or more in length of retort, deduct or add, per retort, s. d.

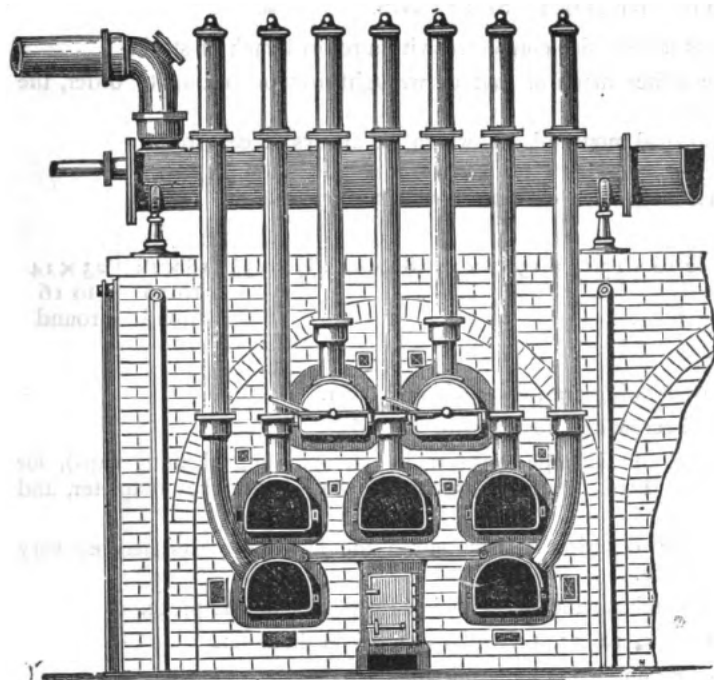

SETTING OF 7 CLAY D RETORTS.

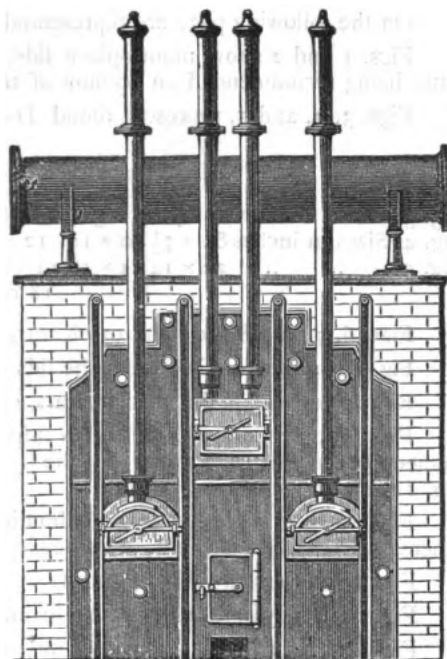

SETTING OF 3 FIRE BRICK RETORTS.

inches inches £ s. d.

With Retorts 8 feet long by 17 by 13, price

For every 6 inches less or more in length of retort, deduct or add, per retort, s. d.

In localities where coal is very cheap, brick retorts are sometimes used on account of their great durability, but against this they demand a larger quantity of fuel for carbonizing than either iron or clay retorts. One of the figures above represents a setting of 3 brick retorts, which, it is almost unnecessary to say, are built within the oven at the time of construction.

CEMENTS.

**COMMON IRON CEMENT.**—To 1 oz. of sal-ammoniac and 1 oz. of flour of sulphur add 32 oz. of clean cast iron borings; mix all well together and keep the composition dry. When it is wanted, add a little water, and when brought to a proper consistence, let it stand a few hours before using it.

Mr. Watt found the cement was improved by adding some fine sand from the grindstone trough.

The cement used for connecting the iron mouthpiece to clay retorts, is the regular iron cement compounded without sulphur, and mixed with an equal quantity of fire clay; it is made of the consistence of mortar, and spread evenly over the joint.

The cement used for luting retort doors is lime mixed with water to the consistence of mortar. When the luting is required to resist a considerable pressure, the lime should be mixed with common moulding sand in the proportion of 1 part lime to 2 parts of sand.

**CEMENT FOR CLAY RETORTS WHEN CRACKED:—**

Fire Clay . . . . .	42 5 per cent	Glass . . . . .	10.0 per cent
Loam Sand . . . . .	42.5 "	Chloride of Sodium . . . . .	5.0 "

This compound is ground well together with water.

**A GLAZE OR CEMENT FOR FIREBRICKS.**—Pound and carefully mix together a double, treble, or a more compound fusible silicate, in which silica, lime, potass, soda, magnesia, oxide of iron, oxide of magnesia, or bichlorate of soda, may be usefully employed; but should local circumstances not admit of this, the good effect produced by potassa, soda, or better bichlorate of soda, in the composition of the cement intended to become vitrified must not be lost sight of; it must be formed into a paste with a small quantity of water so as to be easily used by a bricklayer; the refuse glass dust of glass factories, with 2 per cent of manganese, and 4 per cent of borax will answer the same purpose. When it is cheaper to use potassa or soda, the silica and alumina of the firebricks combine with the alkali and form the vitreous cement, and so on in a variety of ways.—MUSPRATT.

**CEMENT FOR JOINTING THE MOUTH-PIECES OF CLAY RETORTS.**—Four-fifths by weight of fire clay, one-fifth of cast iron borings saturated with a strong solution of sal-ammoniac; mix the two together and apply the same, after the face of the retort has been well saturated with water. By degrees, as the cement dries, the nuts should be tightened.

## ACCESSORIES OF RETORT SETTINGS.

On the following page are represented the various accessories connected with a retort bench or stack.

Figs. 1 and 2 show mouth-piece lids, which are either made of cast or wrought iron, according to order, the latter being recommended on account of their lightness.

Figs. 3, 4, and 5, represent round, D-shaped, and oval mouth-pieces, which are always of cast iron.

## DIMENSIONS OF RETORT MOUTH-PIECES TO GEORGE BOWER'S PATTERNS.

Fig. 3, Diam. in inch.	14	15	18								
Fig. 4, Sizes in inches	8½ × 7½	10 × 10	12 × 12	14 × 12	16 × 15	17 × 13	17 × 14	18½ × 12	18½ × 13½	18 × 14	23 × 14
Fig. 5, " "	22 × 14	24 × 18	24 × 18 to 18 round							to 16 round	to 16 round

Figs. 6, 7, and 8 are sight, or clearing-out boxes.

Fig. 9. is a means of securing the lids of retorts by a swing arm, eccentric and lever.

Fig. 10 represents the ordinary ears, cross-bar, and screw-key, for securing the lids.

Figs. 11, 12, and 13, are an N pipe, curve pipe, and H pipe (with their corresponding cleaning caps), for connecting the ascension pipes with the hydraulic main. Figs. 11 and 13 are made 3, 4, or 5 inches diameter, and Fig. 12, 4 inches diameter.

Fig. 14 is a wrought iron hydraulic main, which description has within the last few years become very generally adopted on account of its freedom from breakage.

Fig. 15 is a cast iron D shaped hydraulic main, 16 inches wide by 13 inches deep, cast in one piece.

Fig. 16 is a cylindrical hydraulic main. Sizes in stock, 10, 12, 14, and 16 inches in diameter.

Figs. 17, 18, and 19, are three forms of crutches for supporting hydraulic mains.

Fig. 20 is a double furnace door and frame.

Fig. 21 is a single furnace door and frame.

Figs. 22, 23, and 24, show three kinds of cast iron buckstaves, in elevation and in section.

Ascension pipes, 3, 4, or 5 inches in diameter; also 4 by 3, or 5 by 4 inches diminished.

## COAL CARBONIZED BY THE METROPOLITAN GAS COMPANIES IN 1875.

COMPANY.	COAL CARBONIZED.				PRICE PER 100 FEET OF GAS SOLD.		TOTAL COST.	
	Newcastle.	Cannel.	Total.	Per Ton.				
	Tons.	Tons.	Tons.	s.	d.	s.	d.	
The Gas Light .	452,752	36,686	489,438	20	9'77	7	26'51	£509,367
Imperial .	428,571	10,503	439,076	18	8'26	2	26'03	410,274
Independent .	60,565	1,924	62,489	20	2'11	3	27'75	63,038
Commercial .	941,883	49,113	991,001	19	9'8			982,679
Ratcliff .	89,769	7,376	97,145	18	7'04	8	25'07	90,277
London .	21,071	291	21,362	16	2'77	1	21'29	17,336
Phoenix .	112,174	3,444	115,618	18	4'09	3	24'40	106,025
South Metropolitan	142,784	2,416	145,200	19	4'62	2	25'06	140,739
Surrey Consumers'	89,727	622	90,349	17	1'60	1	22'52	77,398
	43,998	327	44,325	16	5'75	1	24'04	40,953
Total Tons	1,441,411	63,589	1,505,000					£1,455,497

—Field's Analysis.



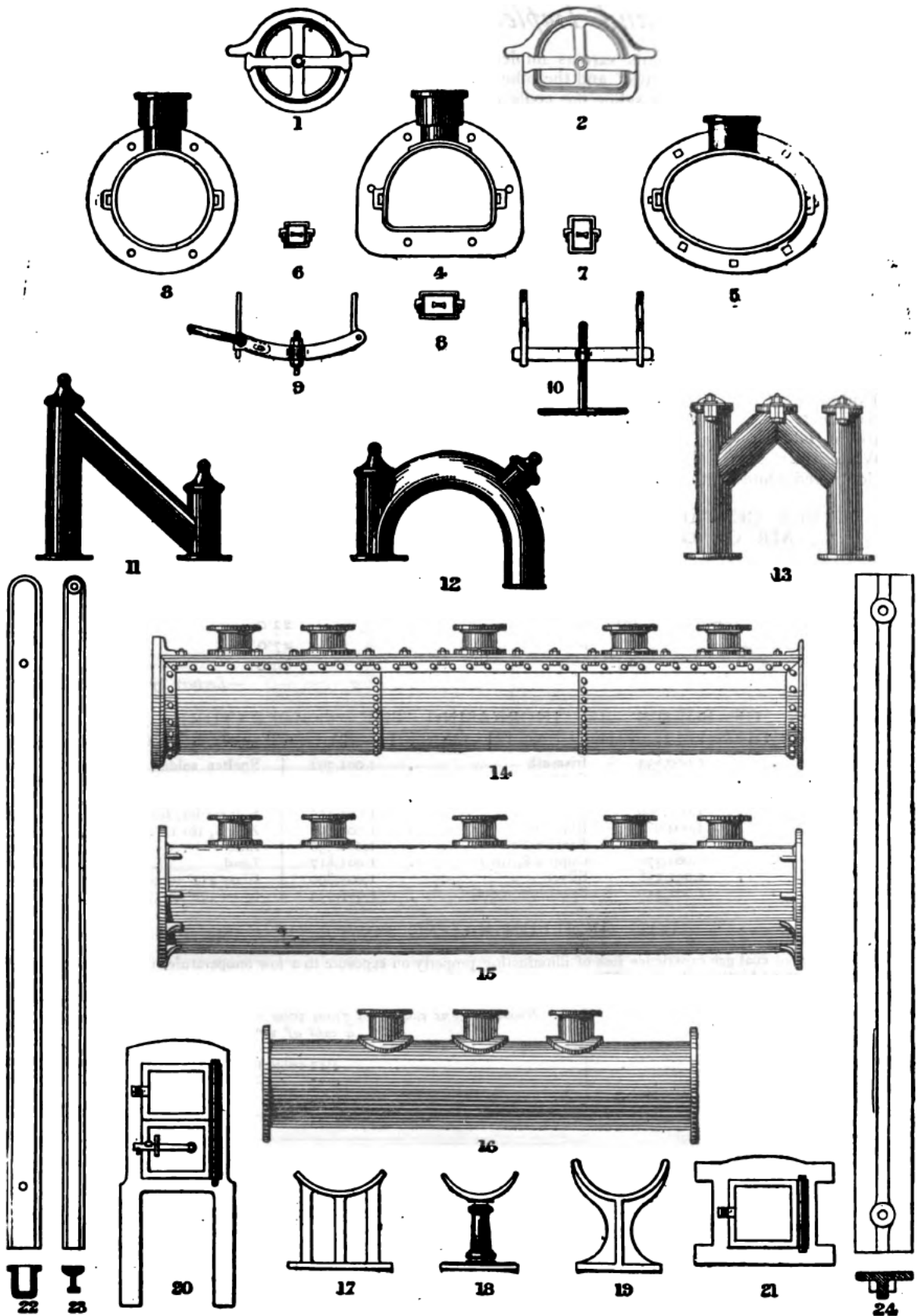

## Tools and Implements of a Gas Works.

The annexed sheet represents various implements necessary for a gas works. Fig. 1 and 2, are two coal waggons. The one being "end tip" and the other "side tip," suitable for any works, having railway communication, as by the construction of a siding the coals can, when required, be delivered directly opposite the furnaces, ready for charging, thus avoiding the expense of cartage, barrowing, and trimming, which augment the cost of the coal very considerably. Figs. 3 and 4 are coke barrows with bodies made of wrought iron plate, rivetted to strong bar iron frames. The bodies are also made entirely of bar iron. Fig. 5 is a coke shovel or fork, which takes up coke only and leaves the breeze. Fig. 6 is a charging shovel, especially adapted for gas works. Figs. 7 and 8 are the two views of a charging scoop, and fig. 8 is the "horse," by which it is lifted to the level of the retort to be charged. The scoop always requires three men for charging the retorts, and for this reason is not adapted for the smallest of works. Fig. 9 is the drawing rake, and fig. 10 is a scurfing bar. Figs. 11 and 12 are furnace rakes; fig. 13 is a clinking bar; and fig. 14 is an auger for passing up the ascension pipes, and removing any obstructions that may exist therein.

TABLE SHOWING THE PROPORTION OF HYDROGEN AND CARBON IN COAL GAS DISTILLED AT DIFFERENT TEMPERATURES:—

Temperature.	Hydrogen.	Carbon.	Name of gas.
Dull red heat . . . . .	100	614	Principally olefiant gas.
Red heat . . . . .	100	580	Olefiant gas mixed with marsh gas.
Bright red heat . . . . .	100	472	
White heat . . . . .	100	325	Marsh.
Continued white heat . . . . .	100	7	Nearly pure hydrogen, the carbon deposited.

TABLE OF PER CENTAGE OF VAPOUR OF PETROLEUM SPIRIT OF S G '650 PRESENT IN AIR OR OTHER MEDIUMS AT DIFFERENT TEMPERATURES:—

Temperature.	Per Centage.
32° Fahr.	10·7
50° "	17·5
60° "	22·0
68° "	27·0
104° "	39·0

—Lecture by J. Wills, F.C.S.

EXPANSION OF SOLIDS BY INCREASING THE TEMPERATURE FROM 32° TO 212° FAHRENHEIT, THE LENGTH OF THE BAR AT 32° BEING 1,000,000.

Glass tube . . . . .	1,000,833	Bismuth . . . . .	1,001,392	Spelter solder, brass 2, zinc 1 . . . . .	1,002,058
Plate glass . . . . .	1,000,890	Gold . . . . .	1,001,500	Tin . . . . .	1,002,483
Platina . . . . .	1,000,884	Copper . . . . .	1,001,910	Soft solder, lead 2, tin 1 . . . . .	1,002,508
Palladium . . . . .	1,001,000	Brass . . . . .	1,001,875	Zinc 8, tin 1 . . . . .	1,002,692
Antimony . . . . .	1,001,083	Plate brass . . . . .	1,001,892	Zinc . . . . .	1,002,942
Cast iron . . . . .	1,001,111	Brass wire . . . . .	1,001,930	Lead . . . . .	1,002,867
Steel . . . . .	1,001,370	Copper 8, tin 1 . . . . .	1,001,817	Glass 212° to 392° . . . . .	1,000,918
Wrought iron . . . . .	1,001,258	Silver . . . . .	1,001,890	Glass 392° to 572° . . . . .	1,001,111
Iron wire . . . . .	1,001,440	Speculum metal . . . . .	1,001,933		

### LOSS OF ILLUMINATING POWER OF GAS.

All descriptions of coal gas experience loss of illuminating property on exposure to a low temperature, the richest gases losing the largest amount, as shown by the following table:—

Name of Gas.	Hydro-carbons condensed from 1000 cubic feet of Gas on exposure to a cold of 32° Fahr.
Boghead . . . . .	4·42 cubic feet
Ince Hall . . . . .	0·37 "
Methyl . . . . .	0·33 "

—CLEGG on Coal Gas.

### SOLIDS AND LIQUIDS VOLATILIZED.

Ether boils . . . . .	Fahr. 98°	Phosphorus distils . . . . .	Fahr. 219°	Oil of Turpentine boils . . . . .	Fahr. 560°
Liquid Ammonia boils . . . . .	140	Muriate of Lime boils . . . . .	230	Sulphur boils . . . . .	570
Camphor sublimes . . . . .	145	Nitrous Acid boils . . . . .	242	Sulphuric Acid boils . . . . .	590
Sulphur evaporates . . . . .	170	Nitric Acid boils . . . . .	248	Linseed Oil boils . . . . .	600
Alcohol boils . . . . .	176	White Arsenic sublimes . . . . .	283	Sulphur sublimes . . . . .	600
Water and essential Oils boil . . . . .	212	Phosphorus boils . . . . .	554	Mercury boils . . . . .	660

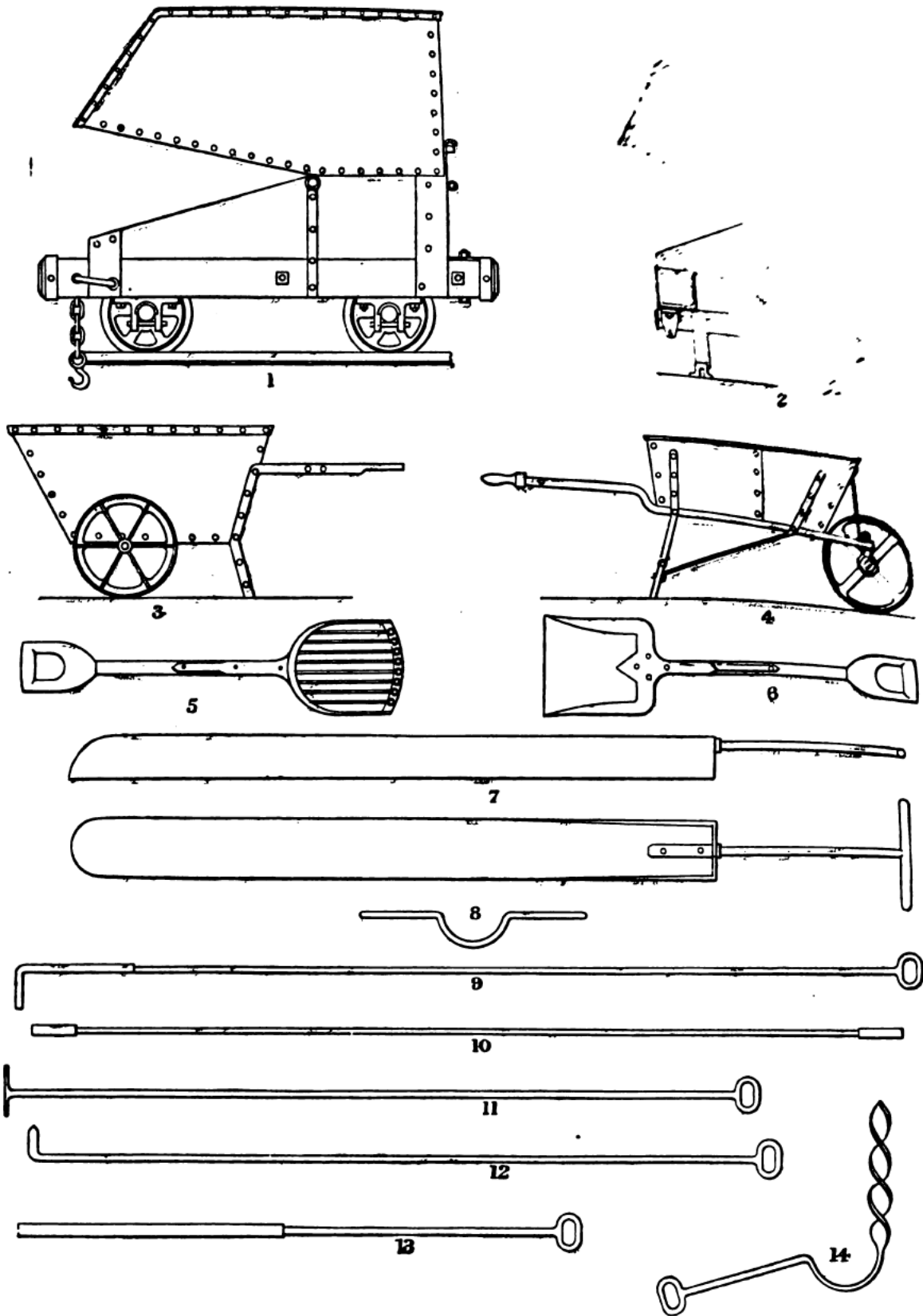

## THE FORMATION OF COAL.

The vegetable origin of coal is too well established now to be questioned, but the difference between the present rate of growth and that existing at an earlier period of the earth's history, is too startling to be overlooked. It is, however, explained by some writers that, at the former period, the earth had not cooled down to its present state, and that this, combined with a warm, humid atmosphere, and assisted by the sun's rays, produced a more than tropical vegetation. The formation of coal is generally ascribed to the agency of drift, or the accumulation of vast bodies of trees and plants at the mouths of large rivers and in estuaries, and which is continually going on.

An extract from Dr. Lardner's "Pre-Adamite Earth" will tend considerably to the elucidation of this subject:—

"At length, "he says," the temperature being reduced to a point compatible with organised life, creative power began to be manifested. The earth was peopled with animals and clothed with vegetation, but these animals and this vegetation differed altogether from those which now animate and cover the globe. They were, however, adapted by Divine wisdom to the then condition of the earth, the temperature being not only greater than any which prevails at present, but also uniform in all latitudes.

"After this, a like succession of convulsions took place, long intervals of time intervening, by each of which the relative levels of the land were changed, and consequently the distribution of the waters of the ocean completely altered; such changes implied universal inundations, which involved the destruction of all animated nature, animal as well as vegetable. In short, a succession of deluges must have attended such convulsions, each deluge destroying all the tribes of animals and plants which existed on the globe at the time of the catastrophe.

"After each of these convulsions, the waters at first turbid, and holding in suspension great quantities of matter washed away and eroded from the former land, as well as enormous quantities of the remains of the animals and plants previously existing, would, after a time, become tranquil, and then a process of vast importance to the preservation of the history of the globe would take place. The organic remains of animals and plants suspended in the waters would be deposited at the bottom of the ocean, and over them would subside also the solid matter sustained in a state of comminution in the waters. The remains would thus be buried in strata sensibly horizontal, and being covered up by the earthy and mineral matter which would subside from the waters, they would be protected from the destructive action of air and water thereafter, and would thus be preserved to future generations as records of the past history of the earth.

"In the interval of tranquillity following each such deluge creative power was again brought into operation, and the earth was re-peopled with animated creatures, and re-clothed with vegetation: but in all cases the animals and plants composing the new kingdoms of nature, though agreeing with those recently destroyed in their classes and generic characters, differed from them altogether in their species. In short, a new kingdom of nature was produced, but constructed upon the same general principles.

"By researches made in the crust of the earth, and careful analyses of the constitution of its strata, and of the animal remains contained in them, geologists have ascertained, that *subsequently* to the first appearance of the forms of animal life, which, as has been stated, took place after the fourth great convulsion of the globe, there were at least *twenty-eight successive convulsions* of a like nature, each of which was attended with the complete destruction of the animals and plants which existed upon the globe, their remains being buried, in the manner already stated, under the sedimentary deposits made by the new oceans which followed the crisis.

"The actual occurrence of these several convulsions, and of the existence of the successive animal and vegetable kingdoms, differing one from another in the species of which they were constituted, has been proved by geologists by two species of evidence, one depending on the condition of the stratification, by which it has been shown that many of these catastrophes were attended with the elevation of systems of mountains which still exist upon the surface of the earth; while others, though not indicated by mountain ranges, are rendered evident by certain discordances and disturbances in the state of the strata."

## THE OXY-HYDROGEN LIGHT.

This was first introduced to public notice by Lieutenant Drummond. It consists of a jet of oxygen and hydrogen gases, or of alcohol and oxygen, burning so as to ignite a piece of lime or magnesia; and the high temperature which is thus produced, renders the earthy body so incandescent as to be intensely luminous. The apparatus which is employed for the production of this light has, at various times, undergone considerable alteration and improvement. Originally, the mixed gases, consisting of two parts by measure of hydrogen and one of oxygen, were condensed by means of a syringe, worked at great pressure, into a square metal box, from which there issued a long jet of very small bore; this jet passed through a thick oak partition, in order that the operators might be protected from the danger which was incidental to the bursting of the metal box from explosion. This was the form of apparatus originally contrived by Clarke and Newman. After this the safety-jets of Gurney, Hemming, and others, were adopted; and at the present time it is customary to burn the mixed gases by means of the latter, or else to deliver the gases separately into a double jet or nozzle, where they mix immediately before they are consumed. Both of these plans are very manageable, though the latter is thought to be less susceptible to the risk of explosion than the former.

The hydrogen gas is obtained by acting on zinc with diluted sulphuric acid (one of acid to ten or twelve of water), and the oxygen, by heating a pulverulent mixture of four parts of chlorate of potash, and one of peroxide of manganese in a glass retort. In each case the gas is to be collected in a gas-holder, or else in bladders fixed to receivers over a pneumatic trough.

When the mixed gases are burnt, the flame is impinged upon a small cylinder of lime or magnesia, which has a rotary motion, in order to expose a fresh surface continually to the action of the flame.

Another mode of obtaining this light, is to throw a jet of oxygen into a flame of spirit of wine or ether, or to mix the oxygen with coal-gas instead of with hydrogen.

The light which is obtained by either of these plans is very intense. When concentrated by means of a concave mirror, it is distinctly visible at a distance of sixty-five miles, and it is calculated, that the mixture of oxygen and coal gas, when compared with the light of a wax candle, is equal to twenty-nine of such candles; that of alcohol and oxygen to sixty-nine; that of ether and oxygen to seventy six; and that of hydrogen and oxygen to one hundred and fifty-three. In consequence of the great intensity of the oxy-hydrogen light, it is generally used for the phantasmagoria, the dissolving views, the solar microscope, and for theatrical illuminations and experiments in optics: besides which, it has been recommended for light-houses and signal lights. The light differs from all others in the circumstance of its being exceedingly white, and therefore well suited for the display of bright and delicate colours. With this light the various shades and tints of a picture or dress are as plainly discernible as they are by the diffused light of day.

## COMPARATIVE ILLUMINATING POWER OF THE GAS SUPPLIED TO VARIOUS TOWNS AND CITIES.

EUROPEAN CAPITALS.			BRITISH CITIES AND TOWNS—continued.		
Name	Authority	Illuminating power in Standard sperm candles	Name	Authority	Illuminating power in Standard sperm candles.
Berlin	Hofmann	15.5	Glasgow	Penny	28.0
Paris	Fremy	12.3	Aberdeen	"	35.0
London	Letheby	12.1	Greenock	"	28.5
Vienna	Redlenbacher	9.0	Hawick	"	30.0
Edinburgh	Penny	28.0	Inverness	"	25.0
			Paisley	"	30.3
BRITISH CITIES AND TOWNS.			Carlisle	"	16.0
Manchester	Leigh	22.0	Birmingham	Frankland	15.0
Liverpool	King	22.0			

[C]

# CONDENSERS,

MANUFACTURED AND SUPPLIED BY

## GEORGE BOWER,

*Gas and Water Engineer and Contractor, St. Neots, Hunts.*

The object of the Condenser is to reduce the vapours intermixed with the gas, when issuing from the hydraulic main, into ammoniacal liquor and tar, by which process the latter is prevented from passing forward to the other apparatus, and impairing their efficiency, and the two residuals are retained. The condenser also serves to reduce the temperature of the gas to the degree most favourable for depositing its ammonia in the washer or scrubber. Lastly, the tar in the condenser eliminates a portion of the sulphuretted hydrogen, carbonic acid, and bisulphide of carbon, and for these reasons the apparatus in question may be regarded as a part of the purifiers.

Condensers are constructed of various forms, and usually consist of a series of ordinary pipes connected together, either vertically or horizontally, by breeches pieces, but, whichever plan may be adopted, each pipe is communicated at the end with that next to it, and in such a manner that the gas passes through the whole length of all the pipes from the inlet to the outlet. For the purpose of cleaning the condenser, whenever it may be desirable, the breeches pipes are provided with suitable caps.

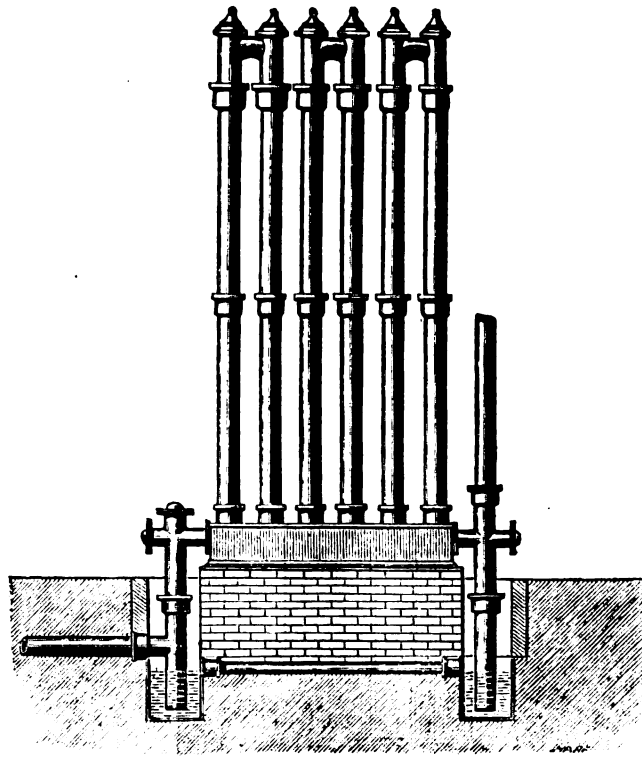

The vertical condenser represented above is composed of a bottom box of cast-iron, furnished at the top with the necessary number of sockets for the respective stand pipes, which are connected to one another in pairs with breeches pieces and cleaning caps. The bottom box is divided into partitions arranged in such a manner that, when the vessel is charged with the necessary quantity of water or tar, the gas shall pass through the whole range of pipes in succession. The box is also fitted with clearing doors, dip pipes and dip cisterns, with bolts, nuts, and all complete, ready for fixing. In condensers having more than 6 pipes, the pipes are arranged in two rows.

CAST IRON VERTICAL PIPE CONDENSERS.

Price—£ s. d.				Price—£ s. d.									
2-in. Condenser, formed of 10 pipes 7-ft. high				5-in. Condenser, formed of 10 pipes 20 ft. high									
3	''	''	10	''	11	''	6	''	''	10	''	20	''
3	''	''	12	''	11	''	8	''	''	6	''	20	''
4	''	''	6	''	11	''	8	''	''	12	''	20	''
4	''	''	14	''	11	''	8	''	''	18	''	20	''
5	''	''	6	''	20	''							

GEORGE BOWER, ST. NEOTS, HUNTINGDONSHIRE.

Another description of condenser is composed of a series of pipes of considerable length, placed in slightly inclined rows one above the other, and connected together at the ends in such a manner that the gas passes through the whole length of the apparatus. The points of juncture of all the pipes are fitted with caps for cleaning; the pipes are supported in various ways, but generally by means of a suitable framing of wrought or cast iron.

The next kind to be described is the Annular Condenser, which in its simplest form is represented below, and consists of an outer cylinder, containing another smaller cylinder concentric to the former, the space between them being closed at the top and the bottom, thus forming an annular chamber through which the gas passes in the process of condensation.

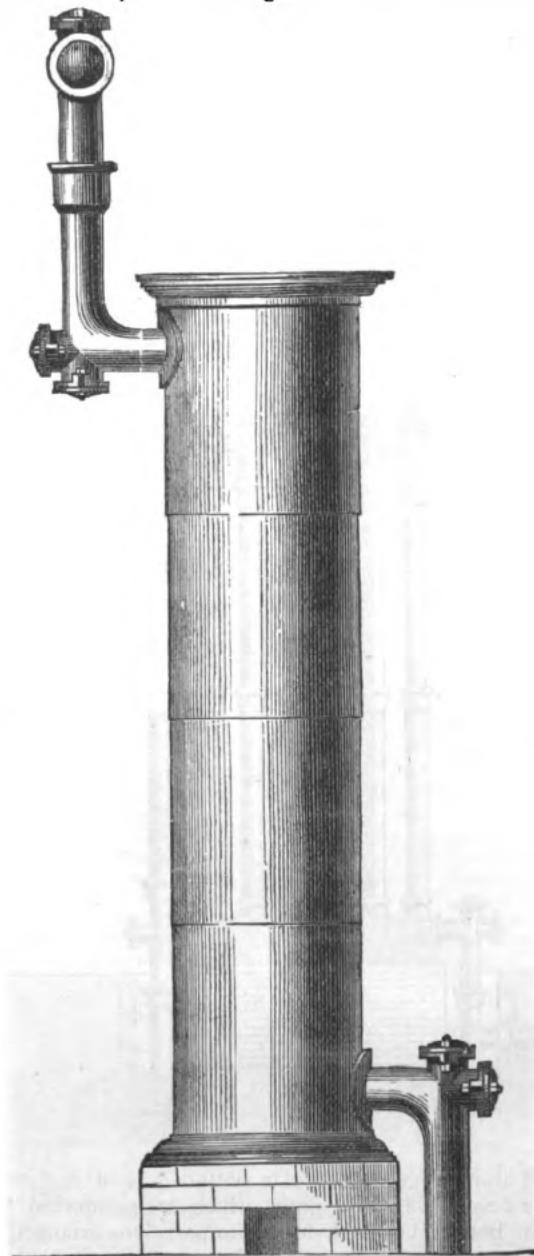

The inlet for the gas is at the top, and the outlet at the bottom, there being an opening at the centre of the base for the purpose of allowing a current of air to flow freely through the apparatus. Thus, by the heat of the passing gas, a strong current of cold air is always passing through the inner cylinder, which, with the cooling surface of the larger cylinder, effectually condenses the vapours in combination with the gas.

These condensers are made either in cast or wrought iron, the latter only being recommended, as more convenient for transport and export.

DIAMETER OF THE CYLINDERS OF THE ANNULAR CONDENSER AS MANUFACTURED BY GEORGE BOWER.

	<i>feet</i>	<i>inch.</i>	<i>feet</i>	<i>inch.</i>	<i>feet</i>	<i>inch.</i>	<i>feet</i>	<i>inch.</i>
Outside Cylinder	1	9	2	0	2	6	3	0
Inside        "	1	0	1	6	2	0	2	6

GEORGE BOWER, ST. NEOTS, HUNTINGDONSHIRE.

For works of medium and large magnitude, a number of these annular condensers are combined, as shown in the annexed figures, and form an apparatus of great efficiency and of excellent appearance. In this the gas passes up one series of pipes and descends in the others, the tar and ammoniacal liquor passing off at the bottom.

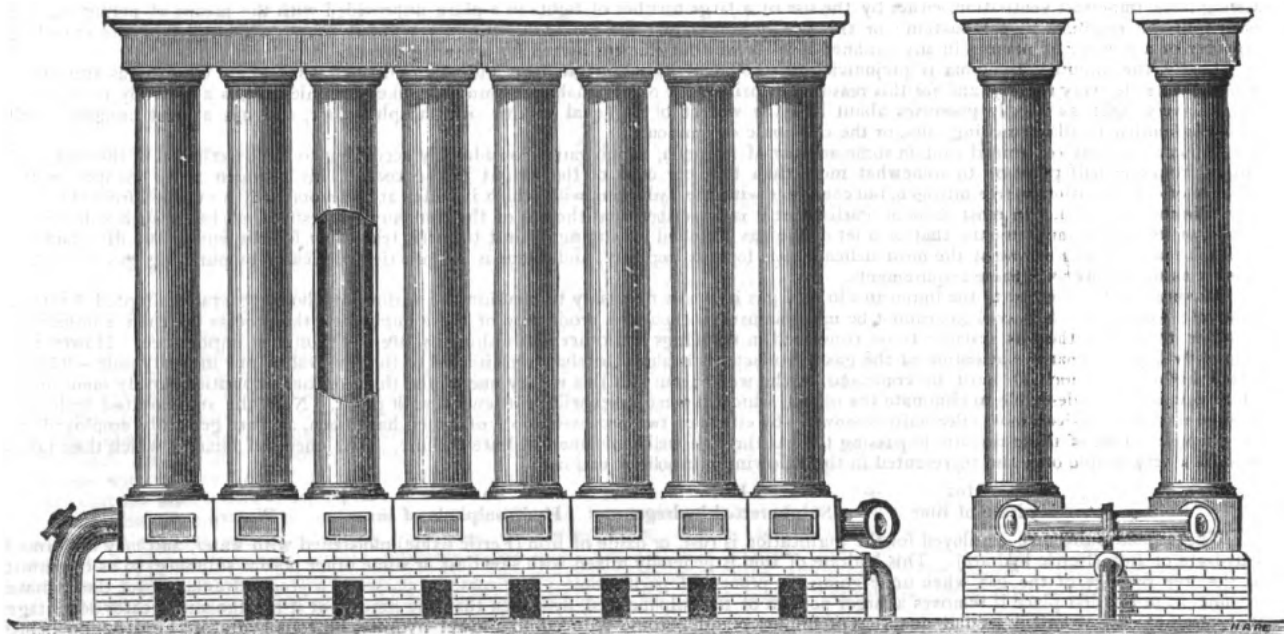

These condensers are made of any desired number of cylinders, magnitude, and design, according to the requirements of the works, and the taste of the directors and engineer of the company.

In hot climates, where the temperature at times is very high and variable, in such places, on account of its uniformity of action, the water condenser is more desirable than that described. The water condenser consists of a shallow tank of suitable length, breadth, and depth, containing a number of lengths of pipes placed in a horizontal position and parallel to each other, which are connected together with cleaning out caps. By these means the gas is caused to flow through a considerable length of pipe, which gives off the caloric absorbed from the gas to the water, and as the water is not influenced by every change of temperature, the action of the apparatus is uniform, alike at mid-day and at night. One great advantage of the annular condenser is that the power of condensation is to some extent under control, by closing or opening the passages for the air to the centre pipes.

• Lastly, a description of apparatus is formed by allowing water to flow gently on to the vertical pipes, when by the conversion of the water into vapour a large portion of the heat is carried off, and the condensation is effected.

### THE CHEMICAL CONSTITUENTS OF COAL GAS.

Crude gas, after leaving the condenser and before entering any portion of the purifying apparatus, contains three distinct classes of constituents which may be conveniently arranged under the heads of IMPURITIES, DILUENTS, and ILLUMINANTS.

The Impurities are Sulphuretted Hydrogen, Carbonic Acid, Carbo-sulphur compounds, Bisulphide of Carbon, and Ammonia.

The Diluents are Hydrogen, Marsh Gas, and Carbonic Oxide.

And the Illuminants consist of Olefiant Gas, Propylene, Butylene, Acetylene, etc.

The first-named impurity, Sulphuretted Hydrogen, is formed by the combination of sulphur and hydrogen at a red heat. Coals of the very best quality always contain a compound known to mineralogists as iron pyrites—a compound of iron with sulphur—called by chemists bisulphide of iron, which is often observed in the bright metallic laminae intersecting coals. Now when hydrogen comes in contact with this compound at the temperature at which gas is made in the retort, it takes from it a quantity of sulphur, and becomes converted into sulphuretted hydrogen.

Sulphuretted hydrogen is a colourless transparent gas, possessing a most disagreeable odour, which is commonly compared to that of putrid eggs. Its specific gravity is 1.171, being slightly higher than that of common air. It burns with a blue flame, but is entirely destitute of light. One of its peculiarities is the property of discolouring paint, and, consequently, it is a most objectionable impurity in coal gas. Almost all paints contain carbonate of lead, which is acted upon by sulphuretted hydrogen, exactly in the same way as the acetate of lead test paper when submitted to its influence. This test paper, on being applied to a stream or jet of gas containing the impurity in question, is at once discoloured, and when the gas is very impure, a black sulphide of lead is formed.

Carbonic acid is always generated in the process of manufacturing gas, simply because coals of all descriptions contain oxygen, and during the process of carbonization part of this oxygen unites with the hydrogen also present in the coal, and thus produces water. The remainder of the oxygen then combines with carbon, and in so doing generates two distinct products, one of which, viz. carbonic acid, belongs to the impurities, whilst the other, carbonic oxide, is one of the number of diluents. Carbonic acid contains the largest amount of oxygen that ever combines with carbon. It is perfectly colourless and transparent; it has an agreeable pungent taste and odour, and it is half as heavy again as atmospheric air, but cannot be respired for a moment without insensibility following.

This impurity is incapable of combustion, and also of supporting combustion; hence it is not only useless, but is an exceedingly

deleterious compound, acting in a very peculiar and deteriorating manner upon the illuminants contained in the gas, as the presence of only one per cent. of carbonic acid reduces the illuminating power of coal gas about six per cent. Or, in other terms, by removing one per cent. of carbonic acid from the gas its luminosity is increased over six per cent. Hence the great desirability of having gas entirely free from this impurity is obvious.

Carbonic acid is very hurtful to animal life; even when largely diluted with air, it acts as a narcotic poison; hence the danger arising from imperfect ventilation, either by the use of a large number of lights in a place unprovided with the means of permitting the escape of the products of combustion; or the use of stoves and fire-places of all kinds without proper chimneys; or the crowding together of a number of persons in any confined locality without efficient means for renewing the air.

Lastly, the impurity ammonia is prejudicial on account of its action on brass and copper fittings, such as are used in gas apparatus, which it corrodes very rapidly, and for this reason it is principally objectionable. Ammonia, like carbonic acid, is a perfectly transparent gas, and very light, as it only possesses about half the weight of an equal volume of atmospheric air, and has a most pungent smell which is familiar to all in smelling-salts, or the carbonate of ammonia.

All coals hitherto examined contain some amount of nitrogen, which varies considerably according to the description of the coal, and ranges from one half per cent. to somewhat more than two per cent. of the weight of the coal. This nitrogen never escapes in the process of carbonization as free nitrogen, but combines with the hydrogen, with which it unites at the moment it is expelled from the coal, thus forming ammonia. In most Acts of Parliament it is prescribed that the gas of the company interested shall be of such a degree of purity, or freedom from ammonia, that on a jet of the gas supplied impinging against turmeric test paper for one minute, no discoloration shall take place. This is one of the most delicate tests for this impurity, and there is no practical difficulty in purifying gas in such a manner as to comply with these requirements.

Having briefly referred to the impurities in coal gas it is now necessary to mention the various methods generally adopted for their removal; for, inasmuch as coal gas cannot be manufactured without the production of these impurities, the process for their elimination, in order to render the gas suitable to be consumed in dwellings and other establishments, are of the utmost importance. However, it frequently happens that the attention of the gas-manufacturer is almost exclusively directed to the removal of one impurity only—sulphuretted hydrogen—which, it must be confessed, is the worst; but still this is only one of the three or four impurities already mentioned, whereas it is always desirable to eliminate the others, which in some cases will be attended with profit. Now the sulphuretted hydrogen may be removed—indeed most effectually removed—by either of two processes, both of which have been, and are generally employed for the purpose. One of these consists in passing the gas through well-moistened hydrate of lime. The chemical change which then takes place is a very simple one, and represented in the following symbolic equation:—

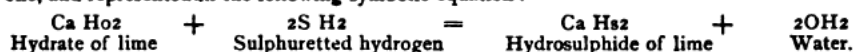

The second substance employed for the purification is rust, or oxide of iron (Ferric oxide) moistened with water, and may be termed a hydrate of iron (Ferric hydrate). This hydrate of iron is generally mixed with saw dust or some other porous substance, so as to permit of the free passage of the gas when undergoing the process of purification. The material possesses a great advantage over the hydrate of lime, as in the first place it removes a larger portion of the sulphuretted hydrogen than the lime; but it has the still greater advantage that, after having absorbed its full quantity of impurity and become reduced to a lower hydrate, Ferrous hydrate,  $2\text{Fe Ho}_2$ , on being exposed to the atmosphere it takes up more oxygen and water, and becomes reconverted back to the first hydrate, or Ferric hydrate,  $\text{Fe}_2\text{Ho}_6$ . Thus the sulphur remains in the hydrate as free sulphur, and the hydrate of iron is regenerated, and ready again to begin its work, which process of reconverting the Ferrous or lower hydrate into the Ferric or higher hydrate is technically termed "revivification."

The chemical changes which occur in the processes are given in the following table of symbolic equations:

PURIFICATION OF GAS FROM SULPHURETTED HYDROGEN.

*By hydrate of iron.*

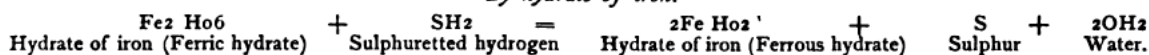

*Revivification.*

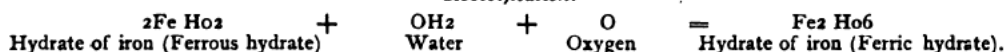

The hydrate of iron process is by far the most economical for the removal of sulphuretted hydrogen from the gas, in consequence of the method of revivification, as in many cases the same substance may be employed as a purifying agent, and afterwards revived as many as thirty or forty times before it is ineffective, when the sulphur may be distilled off, and the oxide again becomes useful; but not to its original degree.

Theoretically, the same quantity of hydrate of iron can be used in the process of purification for ever, but practically its power comes to an end by oft repeated applications, owing to a small portion of sulphur at each operation becoming combined with it, and when this sulphur arrives at about half the weight of the oxide, it is generally disposed of for manufacturing purposes.

But although the hydrate of iron is so admirably suited for eliminating the sulphuretted hydrogen, it has no effect upon the other impurity, carbonic acid; for this the hydrate of lime is essential, and care should be taken that it is well moistened, alike for the absorption of carbonic acid, as well as the other impurities in the gas.

The impurity, ammonia, is removed from the gas with the greatest facility by means of the scrubber or washer, for with either of these apparatus the gas is brought in contact with the water, which has a powerful affinity for, and absorbs the ammonia. In this operation, only just sufficient water, and no more, should be employed, and as indicated hereafter in all works producing twenty million cubic feet per annum, the ammonia resulting from the purification should be made a source of revenue.

According to a series of experiments made by Mr. Lewis Thompson, "during the distillation of the ordinary kinds of Newcastle coal the quantity of ammonia given off by each ton is equal to the manufacture of about 38 lbs of sulphate of ammonia. Of this rather less than one-third is contained in the ammoniacal liquor, and somewhat more than two-thirds exist in the gas. The gas liquors from one ton of coal may be taken on an average at 10 gallons, each gallon of which will yield from 18 to 20 ounces of commercial sulphate when properly treated with sulphuric acid."

We now come to the consideration of the sulphur compounds and the bisulphide of carbon, the entire removal of which is undoubtedly one of the most important problems in connection with the purification of coal gas; and although considerable progress has been made in this during the last few years, much has yet to be accomplished before the process can be pronounced satisfactory. Bisulphide of carbon is what chemists call a sulphur-acid, and it possesses the power of combining with sulphur bases so as to form fixed salts. Now one of these sulphur bases is the hydrosulphide of lime, or the ordinary foul lime of the dry lime purifiers; and this hydrosulphide of lime is capable of slowly combining with the bisulphide of carbon. But in order that this should be more effective, it has been discovered, that the gas undergoing the process of purification should be first freed from its carbonic acid; which effected, the bisulphide of carbon is more readily absorbed by the hydrosulphide of lime. This system of purification is applied by the largest Metropolitan establishment, where the principal purifying agent adopted is the oxide of iron, which has no affinity for the bisulphide of carbon. The amount of sulphur impurity in coal gas is regulated by Act of Parliament, to be limited to 20 or 25 grains of sulphur in 100 cubic feet.



The sulphur which is contained in gas apart from the sulphuretted hydrogen, may be detected by examining the products of combustion of the gas, because during the process of combustion it combines with the oxygen of the atmosphere and water, so forming sulphurous and sulphuric acids, which may be condensed by ammonia. Therefore, if the products of combustion are passed through a glass cylinder containing a weak solution of ammonia, the sulphur will be absorbed by this, and the sulphate of ammonia formed. From this it would appear an easy matter for chemists to determine the quantity of sulphur contained in a given quantity of gas, which, however, is not the case, on account of a portion of the sulphur passing off without being absorbed by the ammonia. Therefore, when the chemist collects the liquid from the cylinder he is minus that quantity which has escaped. The best method of detecting the amount of this impurity is that described in Section A, page 19.

After the removal of the impurities, as already observed, gas contains two classes of constituents. To one of these the name of diluents has been given, because they perform a function in coal gas which can be most appropriately termed a diluting function. They do not contribute directly to the light obtained from coal gas to any appreciable extent, but they do so indirectly; since these gases, although not luminous themselves in burning, are capable of absorbing or taking up the vapours of luminiferous hydrocarbons, such as enter into the composition of coal tar and coal naphtha, both products of the destructive distillation of coal.

This power of the diluents for taking up or holding in suspension the hydrocarbon vapours is readily illustrated. For this purpose a shallow box, hermetically closed, is charged to about half its height with benzole, one of the volatile constituents of coal, and so arranged that hydrogen gas may be caused to pass through it. If now a stream of hydrogen gas be ignited in its pure state, either at a fishtail or batwing burner, it will give no appreciable light; but, on causing the hydrogen to pass through the box containing the benzole, then the light emitted from the burner will be very considerable, indeed, superior to that evolved by ordinary coal gas.

In addition to this property or function of taking up and carrying forward these volatile hydrocarbons, one of these diluents, namely light carburetted hydrogen or marsh gas, burns with a yellow flame, producing but little light. But when its temperature is much elevated the illuminating power of the gas is increased very considerably. Therefore marsh gas may be said to stand on the line of demarcation between the diluents and the illuminants.

To this property possessed by marsh gas of giving greatly increased luminosity when heated, is undoubtedly due one of the causes of the augmentation in the illuminating power obtained by heating the air before it comes in contact with an ordinary gas flame; and inasmuch as marsh gas enters very largely into the composition of gas, it follows, that by bringing out its illuminating effects we must obviously get a considerable increase of light.

Marsh gas in itself is perfectly innocuous. The labourers in coal mines can breathe an atmosphere containing 11 per cent of this gas without any deleterious result, and they are, in fact, unconscious of its presence, except by the indication of the safety lamp, that the atmosphere is explosive.

The other diluent, carbonic oxide, is a combustible, and burns with a pale blue flame, generating carbonic acid. It is colourless, has very little odour, and is extremely poisonous, even worse than carbonic acid; in fact, when present in the atmospheric air to the extent of two per cent, would probably prove fatal, and certainly recovery from its effects would be much more doubtful than from a like quantity of carbonic acid. It is this material, in all probability, which kills in the process of suffocation by the fumes of charcoal. This gas is frequently observed, ignited, issuing at the upper part of the mouth piece, after a charge of coal is well burnt off.

The third class of constituents present in gas are the illuminants, the chief of which are mentioned in the following table of the

PRODUCTS OF THE DESTRUCTIVE DISTILLATION OF COAL.

	Formula.	Boiling point.
Hydrogen	H H	—
Marsh Gas	C H <sub>4</sub>	—
Paraffin	C <sub>n</sub> H <sub>2n+2</sub>	—
Olefiant Gas or Ethylene	C <sub>2</sub> H <sub>4</sub>	—
Propylene	C <sub>3</sub> H <sub>6</sub>	—
Butylene	C <sub>4</sub> H <sub>8</sub>	—
Acetylene	C <sub>2</sub> H <sub>2</sub>	—
Benzole	C <sub>6</sub> H <sub>6</sub>	176°
Parabenzole	C <sub>6</sub> H <sub>6</sub>	207°
Toluol	C <sub>7</sub> H <sub>8</sub>	230°
Cumol	C <sub>9</sub> H <sub>12</sub>	284°
Cymol	C <sub>10</sub> H <sub>14</sub>	338°
Napthalene	C <sub>10</sub> H <sub>8</sub>	410°
Paranapthalene, or Anthracene	C <sub>14</sub> H <sub>10</sub>	617°

The above table embraces nearly all the substances described by Dr. Frankland, and according to the Rev. W. R. Bowditch the greater portion of these are components of gas tar. The question therefore arises, can the hydrocarbons be absorbed by the tar, when the gas passes therethrough.

The first of the illuminants which it will be necessary to notice is acetylene, which, on account of recent investigation, and from certain peculiarities it possesses, has a special interest for gas manufacturers. Acetylene is a constituent of coal gas, and is probably never absent from that gas. It possesses the peculiarity of producing a red precipitate when brought into contact with sub-chloride of copper, forming acetylide of copper. Acetylene is a colourless and transparent gas, having a peculiar and rather unpleasant odour; its specific gravity is .92, being slightly less than air, or just thirteen times heavier than hydrogen; it is tolerably soluble in water, and burns with an intensely luminous flame. Acetylene, when added to chlorine, explodes by the action of diffused day light even, but especially of the diffused electric light. This explosion is attended with a very slight report, but with the evolution of a large quantity of carbonaceous smoke.

The illuminant, olefiant gas, is colourless, transparent, and therefore invisible, and burns with a beautiful brilliant flame, but not nearly so bright as that of acetylene, for the reason that it contains, in an equal volume, the same amount of carbon and twice as much hydrogen as the last-mentioned gas. Olefiant gas is slightly soluble in water.

The next illuminant is benzole, which is contained in coal tar and naphtha. It is a limpid, colourless liquid, which refracts light strongly, solidifies at the freezing point of water, and boils at 176° Fahrenheit. A large quantity of this vapour can, therefore, be taken up in the diluents in coal gas, as already described.

Another illuminant, naphthalene, is a very beautiful substance in appearance, indeed, one of the most beautiful crystalline bodies with which chemists are acquainted, and is the cause of great annoyance to the gas manufacturer. For this substance, being very volatile, is carried along with the gas into the street mains as a colourless, invisible vapour, and then with the gradual diffusion of hydrogen and other constituents through the pores of the pipes, as also by the lower temperature of the pipes through which the gas is conveyed, the gas becomes super-saturated with the naphthalene, so that large masses of this are deposited in the mains, and produce obstructions that are difficult to remove. This naphthalene is capable of contributing very largely to the illuminating effect of a gas flame, if it can be introduced at a sufficiently elevated temperature.

The greater portion of the preceding is compiled from an admirable lecture delivered by Dr. Frankland at the Royal Institution some years ago, which is undoubtedly one of the most instructive communications ever published respecting gas. It is to be regretted that space does not permit of a more copious extract, as the whole is replete with valuable information, and, as shown, the only feasible reason for the production of naphthalene in mains is given for the first time.

THE RELATIVE COOLING EFFECTS OF WATER AND AIR.

The relative effects of water and of air as cooling agents for the condensation of vapours have been experimentally determined by Peclet to be as follows:—

Excess of Temperature in the Gas.	Quantity of Heat lost by a square unit of exterior pipe surface.	
	When radiating in Air.	When plunged into Water.
For an excess of 10°	8	88
" 20°	18	266
" 30°	29	5353
" 40°	40	8944
" 50°	53	13437

It appears from this table that the condensing effects on the exposure of vapours to water increases on a greatly increasing ratio with the difference of temperature; so much so, indeed, that when radiating in air the heat lost is nearly in arithmetical ratio to the increase of temperature; whereas, when plunged into water, the heat absorbed, when the excess of temperature is increased to 50°, amounts to 153 times the quantity absorbed when the excess is only 10°.

Some kinds of coal gas require greater condensing power than others. The coals from the Midland Counties, for instance, yield twice the quantity of aqueous vapour that Newcastle coal produces during distillation; therefore it is desirable to have the means of regulating the condensing power according to the quality of the coal, as well as to the temperature of the atmosphere.—CLEGG on Gas Coal.

ILLUMINATING POWER OF GAS FROM VARIOUS COALS.

Name of Coal.	Consumption of Gas per hour.	Light in Standard sperm candles.	Name of Coal.	Consumption of Gas per hour.	Light in Standard sperm candles.
Boghead Cannel	5 cubic feet	52.6	Methill	5	27.8
Lesmahago	5	40.0	Wigan	5	22.1
Brunswick Cannelite	5	37.8	Newcastle Coal	5	14.9
Newcastle Cannel	5	34.4			—Dr. Frankland.

COMPARISON OF THE COST OF GAS AND OTHER MEANS OF LIGHTING.

The following table exhibits a comparison of the cost of gas with that of other sources of light, from which the enormous advantage of gas will be seen. Comparative value of the light of 20 sperm candles, each burning for 10 hours at the rate of 120 grains per hour.

Wax	s. d.	7 2½	Sperm Oil	s. d.	1 10
Spermaceti		6 8	Rock Oil		0 7½
Tallow		2 8	Cannel Gas		0 3
Paraffin		3 10	Coal Gas		0 4½

ATMOSPHERICAL EFFECTS.

Our atmosphere, although comparatively light, is ponderable, and, consequently at the lowest point, as at the level of sea, it has to support the weight of the whole mass above; therefore its pressure will be the greatest at the lowest point, and this we will suppose to be indicated by the barometer as 30.2 inches of mercury. But if we ascend in a balloon, then, on account of having less weight of air above us, on reaching an elevation of about 1,700 feet the pressure would be reduced to 28.2 inches; and still ascending, on reaching a height of about 7,400 feet, the pressure is further diminished to 22.2 inches, and on attaining the elevation of 2,705 miles the barometer would indicate but 15.1 inches. At this point, the atmosphere would have just half the density it possesses at the level of the sea, or two cubic feet of air or gas, taken from that height and brought to the lowest point would contract into the volume of one cubic foot.

It follows from the preceding, that according to the elevation of a town or city above the level of the sea, so will be the volume of gas obtained from a given quantity of coal. Thus, if a gas works existed at a height of 2,705 miles the average make would be 20,000 feet per ton of coal; at 7,400 feet, it would be about 13,000 feet per ton; and at 1,700 feet the make diminishes to 10,700 feet, supposing that at the level of the sea the yield to be 10,000 feet per ton. In these remarks, no reference is made to the temperature of the gas, which is another important consideration when its volume is considered, as it increases or decreases in bulk nearly 2 per cent. for any augmentation or diminution of 10° Fahr. Thus 1,000 feet of gas at 60° will be expanded to 1,020 feet at 70° Fahr.; or 1,000 feet at 60°, when reduced in temperature to 50°, will contract to 980 feet. It may be further remarked, that in all localities the pressure of the atmosphere is constantly varying to a slight degree, according to the weather and other causes, and to ensure strict accuracy in manipulating with gases, these changes with their effects should be considered.

But the barometric pressure affects also the illuminating power of the gas, which, according to Dr. Frankland, varies in the following manner:—

Pressure of air in inches of Mercury.	Observed illuminating power.	Pressure of air in inches of Mercury.	Observed illuminating power.
30.2	100.0	18.2	37.4
28.2	91.4	16.2	29.4
26.2	80.6	14.2	19.8
24.2	73.0	12.2	12.5
22.2	61.4	10.2	3.6
20.2	47.8		

In the lecture from which this is abstracted the operator demonstrated the accuracy of his statements by exhausting the air by means of a pump, by which the various degrees of reduction of light were shown to correspond with the table. "Now," says Dr. Frankland, "the operation of the law of reduction of light by reduction of pressure is such that the illuminating effect of the same gas, when burnt in different localities, is liable to very considerable variations. For instance: if we were to burn in Munich the same sample of gas that we are burning in London—Munich being 1,700 feet above the level of the sea—we should find that an amount of gas which here gives the light of 100 candles would there give the light of 91 candles; and if the same gas were burned in the city of Mexico, which is about 7,400 feet above the level of the sea, it would give the light of only 61½ candles. These calculations are entirely independent of the consideration of the change of volume: if this be taken into account, the difference becomes much greater. Equal volumes of gas burned in London and Mexico would bear the proportion of 100 to 46.2. Therefore, in addition to the gas being much expanded in high elevations, by the lightness of the atmosphere, it yields diminished light; from which we may adduce that one of the purposes of our atmosphere is for transmitting light, as well as sound."

[D]

GEORGE BOWER,

*Gas and Water Engineer and Contractor, St. Neots, Hunts.*

## THE EXHAUSTER.

When gas, during the process of carbonization, is subjected to excessive pressure, arising either from that produced by the weight of the gas-holders, or the resistance in passing through the purifiers, meters, or hydraulic main, a portion of its richest constituents for illuminating purposes is deposited on the interior of the retorts as a hard carbonaceous incrustation, which deposit is further facilitated by high temperature. Hence from personal observation, when clay retorts are worked at the heat corresponding with a very bright orange colour as seen by ordinary daylight, with a pressure of about 24 inches, a coat of carbon of an average thickness of one inch will be deposited on the interior surface of the retort in about fifteen days. If, however, the pressure be reduced by the exhauster to one inch, the retorts having a temperature of dull orange colour—which is considered the most favourable for the production of gas, but is only practicable with clay retorts—then under these conditions of reduced temperature, and more particularly the diminished pressure, about four or six months will be requisite to produce the same amount of deposit. Hence we can understand the pernicious effects of excessive pressure, and which may be easily avoided by the use of the exhauster.

The evils engendered by this deposit of carbon are, firstly, a diminished quantity and quality of gas per ton of coal carbonized. The space occupied by it reduces the capacity of the retort, and consequently the charge of coal, thus augmenting the labour of carbonization. The expenses of wear and tear are increased by its presence. Lastly, this incrustation forms a non-conducting mass, which impedes the passage of the heat from the furnace to the coal undergoing carbonization, by which the fuel required for the furnaces is considerably increased.

The exhauster is an effectual means of avoiding, or, at least, of reducing these evils to a minimum, and as its name implies, it *exhausts* the gas from the retorts the instant it is produced; thus preventing any accumulation that would occasion a degree of pressure beyond that desired. This instrument is simply a pump, actuated by a steam or gas engine, the speed of which is in direct relation with the make of gas, and by means of a pressure gauge in communication therewith, its effects are seen at a glance.

The apparatus in question is generally placed after the condenser, and before entering the scrubber, for the purpose of avoiding any unnecessary accumulation of tar in the scrubber, which would impede its action by clogging up the pores of the coke. In combination with the exhauster is the exhaust governor, and on this being weighted to the desired degree of pressure, irrespective of the quantity of gas produced in any given time, the pressure required in the hydraulic main or retort is rigidly maintained. A pressure gauge is also attached in combination with the exhauster, by which the pressure within the mains can be observed at any moment, and in some works the exhaust pressure register is employed, which records continuously the pressure on the retorts.

An error often committed by some engineers and managers, is to be guided by the pressure within the hydraulic main, and to forget the pressure produced by the seal of the dip pipes; however, for correct working a knowledge of the depth of these seals is absolutely indispensable. For instance, if we suppose the seal of the dip pipes to be 3 inches, then in order to retain a pressure of one inch within the retort, the exhauster would be required to work in such a manner as to indicate two inches exhaust, or partial vacuum in the pressure gauge, and the regulator should be adjusted accordingly.

For economical working, whether iron or clay retorts are in use, exhausters have become almost indispensable, and only in establishments of the most limited kind can they be dispensed with. The importance of the exhauster will be understood, when it is stated that there are many works having a make of 3,000,000 feet per annum, where that apparatus is found advantageous, and according to reliable estimates, its cost in such places does not exceed £25 per annum. This limited cost arises from the fact that the fuel employed for the engine consists of breeze or small coal from the ash pans, which has but little value, whilst the trifling attention the apparatus requires, adds comparatively speaking nothing to the labour of the stoker. But if a gas engine be employed, the attention necessary is even less than with the steam engine, whilst the risk of explosion is avoided; and as gas composes only one-fourteenth part of the compound which produces the motive power, the expense is consequently small. It may be added that in all well-managed works of medium or large capacity, the exhauster is employed. When capital is not limited the whole of the apparatus, such as boilers, engines, and exhausters should be in duplicate, in order to be prepared for any emergency, in the event of one or the other becoming ineffective. However, as an exhauster will often work continuously during several years, without any mishap, or requiring any repair, it is advisable in all cases to employ it, except as observed, in works of the most limited description, and where funds are not available, without being in duplicate.

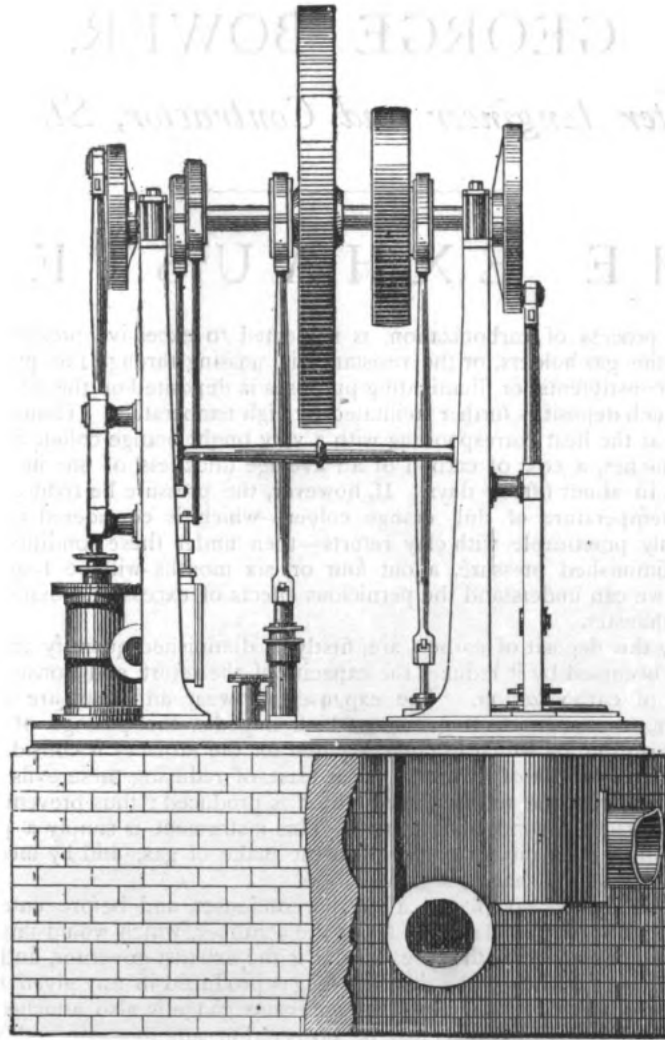

The above engraving represents a Single Exhauster, consisting of a piston and cylinder, with the corresponding valves, attached to the same bed plate which supports the steam engine. The two are connected to one shaft, with fly-wheel, which is supported by cast iron standards, and on the shaft are placed the eccentrics for giving motion to the valves of the engine and the pumps, that may be necessary either for tar, ammoniacal liquor, or other liquids. The whole arrangement is very effective and simple, and can be controlled by any labourer of ordinary intelligence.

Another arrangement of apparatus (Fig. 2, page 39), suitable for large works, is shown in the following engraving, and consists of two exhausters *b b*, in connexion with their corresponding engine *a a*, fixed on a cast-iron bed plate. The piston of each exhauster and engine is attached to the same piston rod, by which means the simplest combination is attained. The regulator *c* controls the action of the exhauster, and prevents the possibility of any excessive exhaustion, which would be highly prejudicial. The by-pass valve *d* admits of the gas being shut off from the exhauster, whenever that may be desirable for the purpose of cleaning the apparatus, or otherwise, and *c* is a self-acting valve which allows the gas to pass freely, in the event of the exhauster becoming inoperative. The whole arrangement is of the most effective description, and fulfils all requirements.

Another kind of apparatus, known as the Rotary Exhauster, is represented in the accompanying engraving. (Fig. 3, page 39.)

When working the exhauster, in order to obtain the best results therefrom, it is essential that a pressure of a few tenths only should exist within the retorts, and the lower this pressure the better, so long as atmospheric air is not allowed to enter and intermix with the gas as produced, either through fissures in the retorts, or leakages in the apparatus, as by the mixture of air with the gas, whether arising from excessive exhaustion or other causes, the illuminating power of the gas is reduced accordingly, as shown in the following table (page 40):—

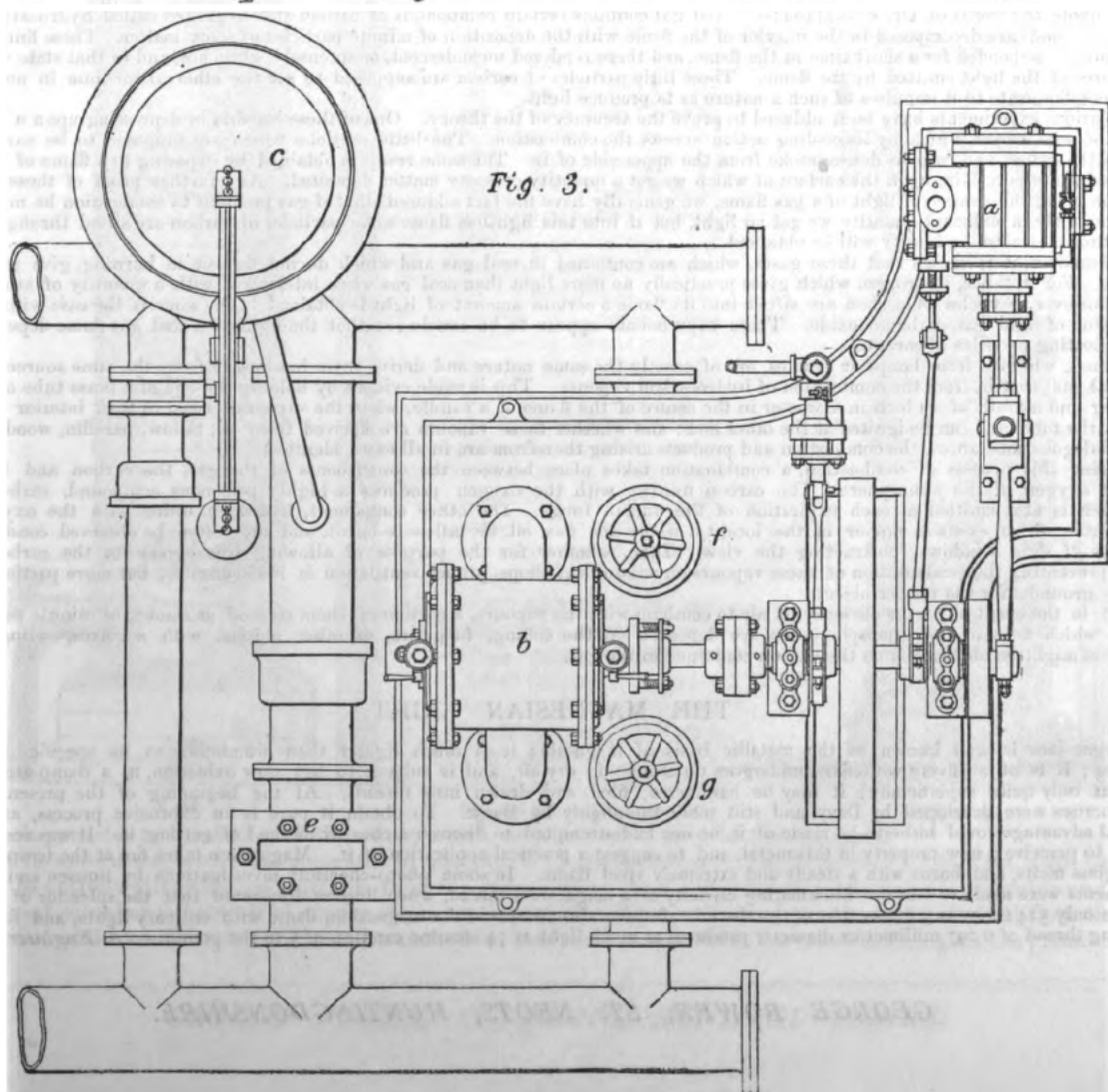
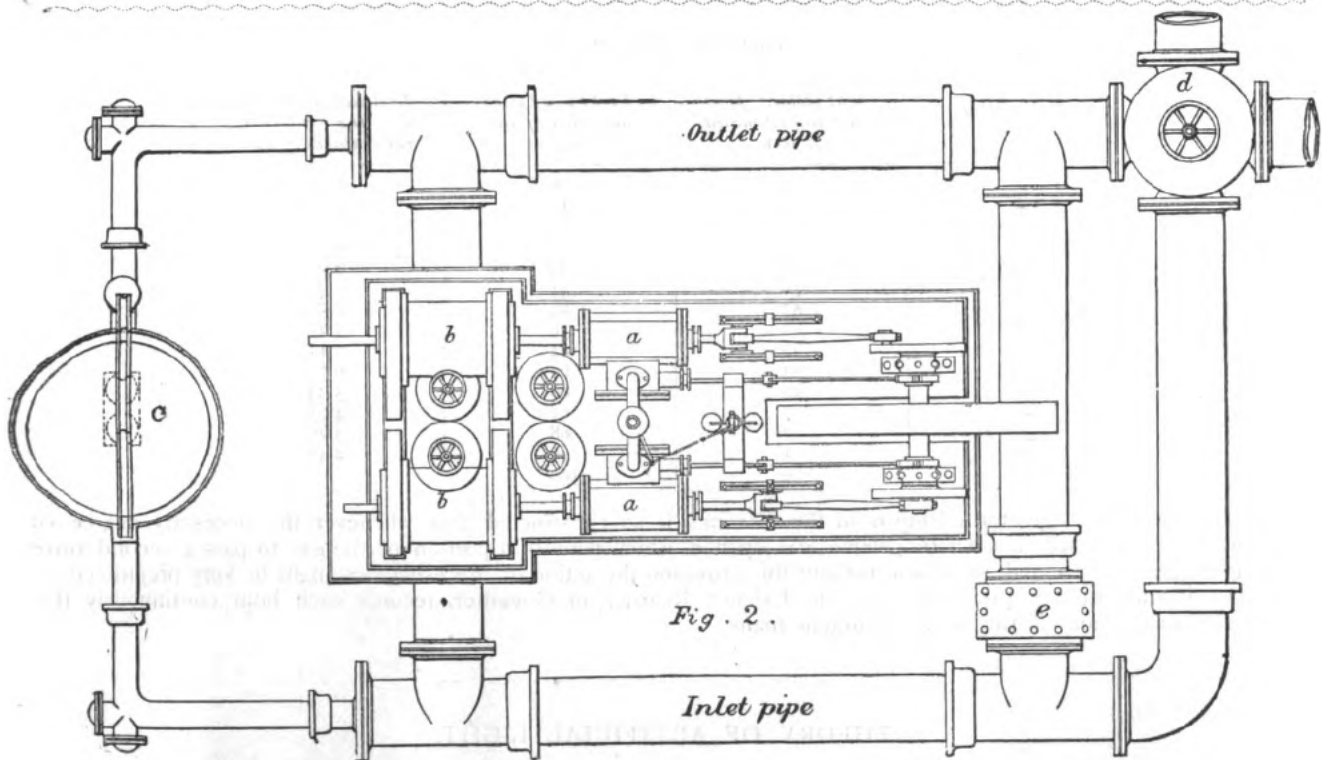

## MIXTURE OF AIR AND GAS.

Quantity of air per cent.	Light yielded, pure gas being estimated at 100.	Light lost by the addition of air per cent.	Destructive power of the various percentages of air.
1	94	6	6·
2	89	11	5·5
3	82	18	6·
4	74	26	6·5
5	67	33	6·6
6	56	44	7·33
7	47	53	7·57
8	42	58	7·25
9	36	64	7·11
10	33	67	6·7
15	20	80	5·33
20	7	93	4·65
30	2	98	3·26
40	1	99	2·47
45	0	100	—

The Exhaust Regulator *c*, shown in the drawings, is so constructed that whenever the necessary degree of exhaustion is exceeded, a self-acting valve *e* is opened, which permits a portion of the gas to pass a second time through the apparatus, and, as shown, without this provision the action of the exhauster might be very prejudicial.

An instrument, hereafter described the Exhaust Register, or Governor, records each hour continuously the degree of exhaustion existing on the hydraulic main.

## THEORY OF ARTIFICIAL LIGHT.

To quote the words of Dr. Frankland:—"Coal gas contains certain compounds of carbon and hydrogen called hydrocarbons, and these compounds are decomposed in the interior of the flame with the deposition of minute particles of sooty matter. These fine particles of carbon are suspended for a short time in the flame, and there rendered incandescent, or intensely white hot, and in that state constitute the source of the light emitted by the flame. These little particles of carbon are supposed to set the ethereal medium in undulation, and to communicate to it impulses of such a nature as to produce light.

"Various experiments have been adduced to prove the accuracy of the theory. One of these consists in depressing upon a gas flame a piece of wire gauze, which by its cooling action arrests the combustion. The little particles which are supposed to be carbon pass through the gauze, and issue as dense smoke from the upper side of it. The same result is obtained by exposing to a flame of this kind a piece of white porcelain, upon the surface of which we get a quantity of sooty matter deposited. As a further proof of these particles of carbon being the source of light of a gas flame, we generally have the fact adduced, that if gas previous to combustion be mixed with atmospheric air in sufficient quantity we get no light, but if into this lightless flame some particles of carbon are sifted through a wire gauze, then a certain luminosity will be obtained.

"Moreover, it is known that these gases, which are contained in coal gas and which do not deposit in burning, give practically no light. For instance, hydrogen, which gives practically no more light than coal gas when intermixed with a quantity of atmospheric air, if, however, particles of carbon are sifted into its flame a certain amount of light is obtained. The same is the case with another constituent of coal gas, carbonic oxide. These experiments appear to be conclusive that the light of a coal gas flame depends upon minute floating particles of carbon."

Flames, whether from lamps or candles, are of exactly the same nature and derive their luminosity from the same source as those from coal gas; that is, from the combustion of hydrocarbon vapours. This is made evident by holding the end of a brass tube of about a foot long and a tenth of an inch in diameter in the centre of the flame of a candle, when the vapours formed in their interior will pass through the tube, and can be ignited at the other end; and whether these vapours are derived from oil, tallow, paraffin, wood, coal, or other analogous substances, the combustion and products arising therefrom are in all cases identical.

During this process of combustion, a combination takes place between the constituents of the gas, the carbon and hydrogen and the oxygen of the atmosphere. The carbon uniting with the oxygen produces a highly poisonous compound, carbonic acid gas, which is also emitted at each expiration of the human lungs. The other component, hydrogen, unites with the oxygen, and forms water, which exists as vapour in the locality, where the gas, oil, or tallow is burnt, and may often be observed condensed on the glass of shop windows, obstructing the view. Then, whether for the purpose of allowing free egress for the carbonic acid gas, or preventing the condensation of these vapours on windows of shops, proper ventilation is indispensable, but more particularly on sanitary grounds, for the former object.

But in the event of an insufficiency of air to combine with the vapours, a portion of them pass off as smoke, or minute particles of carbon, which float in the atmosphere, or are deposited on the ceiling, furniture, or other objects, with a corresponding loss of light, that might be obtained from the carbon contained in the gas.

## THE MAGNESIAN LIGHT.

Magnesium is well known as the metallic basis of magnesia; it is much lighter than aluminum, as its specific gravity is only 1.74; it is of a silvery whiteness, undergoes no change in dry air, and is subject to but slow oxidation, in a damp atmosphere, and that only quite superficially; it may be hammered, filed and drawn into threads. At the beginning of the present century its properties were developed by Davy, and still more thoroughly by Busse. To obtain it pure is an expensive process, and as no practical advantage could hitherto be made of it, no one had attempted to discover a cheaper method of getting it. It was reserved for Bunsen to perceive a new property in this metal, and to suggest a practical application of it. Magnesium takes fire at the temperature at which glass melts, and burns with a steady and extremely vivid flame. In some photo-chemical investigations by Bunsen and Roscoe, experiments were made to test the illuminating capacity of a magnesium thread, when Bunsen discovered that the splendor of the sun's disc was only 524 times as great as that of the thread. Bunsen also compared the magnesium flame with ordinary lights, and found that a burning thread of 0.297 millimetres diameter produces as much light as 74 stearine candles, of 5 to the pound.—*The Engineer*.

[E]

# SCRUBBERS AND WASHERS,

MANUFACTURED AND SUPPLIED BY

## GEORGE BOWER,

*Gas and Water Engineer and Contractor, St. Neots, Hunts.*

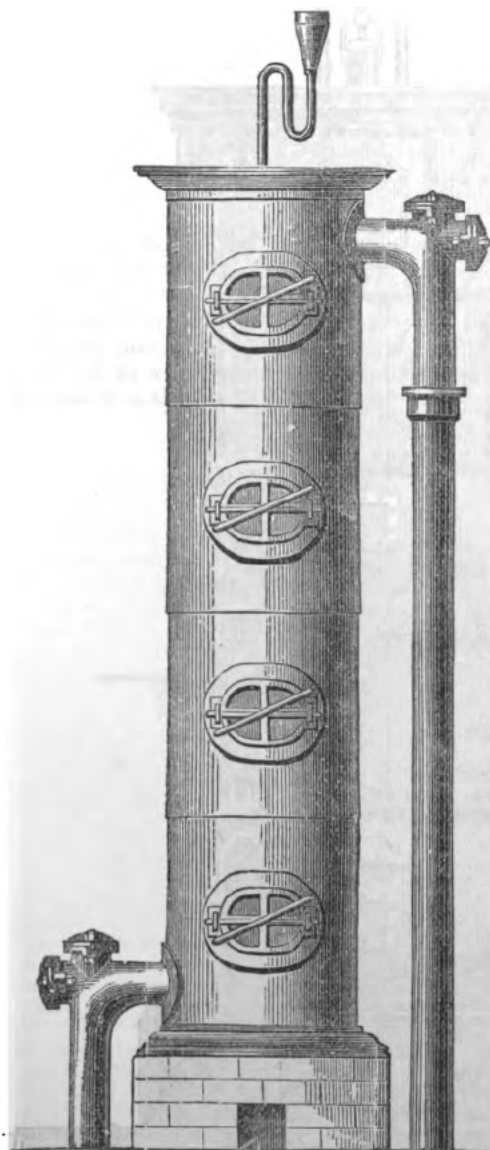

FIG. 1.

On leaving the condenser the first step is to eliminate the ammonia from the gas, for which purpose advantage is taken of the great affinity that water possesses for that compound, and in all well-conducted works, producing ten million feet per annum and upwards, the ammonia derived from the gas should be made a source of revenue, concerning which more will be said hereafter.

There are two kinds of vessels employed for the operation in question, namely, the Scrubber and Washer. The former is a wrought- or cast-iron vessel, either cylindrical or square, of a height considerably greater than its diameter, which is sub-divided into two or more partitions by horizontal cast-iron or wooden gratings, on which the coke hereafter mentioned is placed. At the upper part of the apparatus is provided an arrangement for delivering a continuous and regular supply of water or ammoniacal liquor, which is accomplished either by revolving perforated arms, actuated by motive power, or by a kind of Barker's mill, or rose jets, or other means, which should distribute the water over the whole area of the coke.

The apparatus being filled with coke, the doors securely closed, and the water supplied, it is then ready for action; when the gas, on entering in at the lower part and passing upwards through the interstices formed by the coke, is then broken up, as it were, and pre-

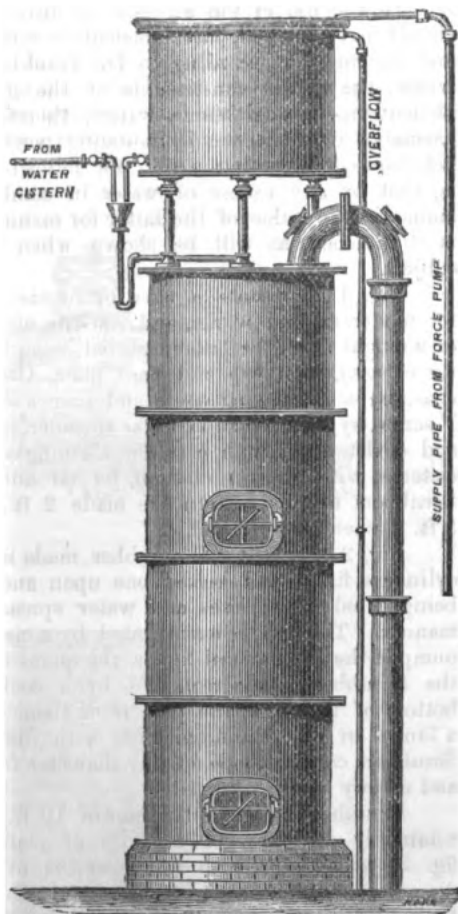

FIG. 2.

sents fresh particles to the action of the water, which, as it descends, absorbs the ammonia.

But in some cases, where the apparatus in question is of limited dimensions, it is requisite to have two scrubbers in order to entirely eliminate the ammonia from the gas. Under these circumstances, the liquor obtained from the first and cleanest scrubber is pumped to supply the second vessel, and, if properly managed, the liquor derived from the latter should be of sufficient strength to render it a marketable commodity, or suitable for manufacturing on the premises. Gas

companies frequently commit the common error of limiting the cost and consequently the efficiency of these apparatus, and naturally they are often ineffective, and the ammonia is lost—the importance of which can be understood when it is stated that, with proper management and good apparatus, on the average about one shilling should be obtained by the sales of ammonia from each ton of caking coal carbonized, and when manufactured on the premises where produced, as hereafter stated, from 2s. to 2s. 3d. per ton should be realised from this source.

Sometimes, when the scrubber is inefficient, the gas liquor is pumped over again several times, in order to bring it to the desired strength; this, however, occasions considerable trouble, besides it is not so effective as when the apparatus is of ample capacity.

It may be observed, according to Mr. Lewis Thompson, "that if all the ammonia has been removed from the foul gas before it reaches the purifier, the amount of gas capable of being purified by a given quantity of lime is much lessened." From which it appears advisable, for the sake of economy, to retain a very small portion of ammonia in the gas after leaving the scrubber, which would be absorbed by the water in combination with the oxide of iron or the lime. But as the operations are often left in the hands of men of limited intelligence, practically it is better to sacrifice the little economy to be derived from the system recommended, and ensure the proper purification of the gas by removing the whole of the ammonia by the scrubber.

In the use of the scrubber as little water as possible should be employed, just sufficient to remove the ammonia and no more, for according to Dr. Frankland, as stated elsewhere, the richest constituents of the gas, acetylene and olefiant gas, are soluble in water; therefore, it follows, by excessive washing, the illuminating power of gas will be deteriorated. Another reason for following this suggestion is, that by any excess of water in combination with the ammonia the value of the latter for manufacturing purposes is diminished, as will be shown when referring to that subject.

Fig. 1 represents a coke or breeze Scrubber suitable for moderate-sized works, and consists of a cylinder of cast or wrought iron (the latter material being only recommended for export), with cap and base plate, two tiers of sieves, charging and drawing doors and frames with cross-bar and T screw, syphon pipe and water spreader, two bends for inlet and outlet fitted with caps for cleaning same, and two dip cisterns, with sockets cast on, for tar and liquor overflow. Scrubbers to this pattern are made 2 ft., 2 ft. 6 in., and 3 ft. diameter, to 9 ft. high.

Fig. 2 represents a Scrubber made up of a number of cylinders fitted and bolted one upon another, the interior being fitted with sieves and water spreader in the usual manner. The top is surmounted by a cistern into which is pumped the ammoniacal liquor, the quantity passing through the Scrubber being regulated by a cock fixed near the bottom of the tank, the pipe from thence discharging into a funnel or pipe communicating with the spreader. These Scrubbers can be made of any diameter from 3 ft. to 10 ft., and of any height required.

Scrubbers having a diameter of 10 ft. and upwards are commonly built up of a series of plates, as shewn by fig. 3, which represents an apparatus of the kind 10 ft. diameter and 25 feet high. The inlet and outlet pipes are both from the bottom, the outlet being attached to a stand pipe passing up the centre of the Scrubber and almost its entire height.

A cistern for ammoniacal liquor is fixed upon the top, and is connected with the spreader by a self-acting feed.

Scrubbers of this description are made to any diameter and height required. Special prices on application.

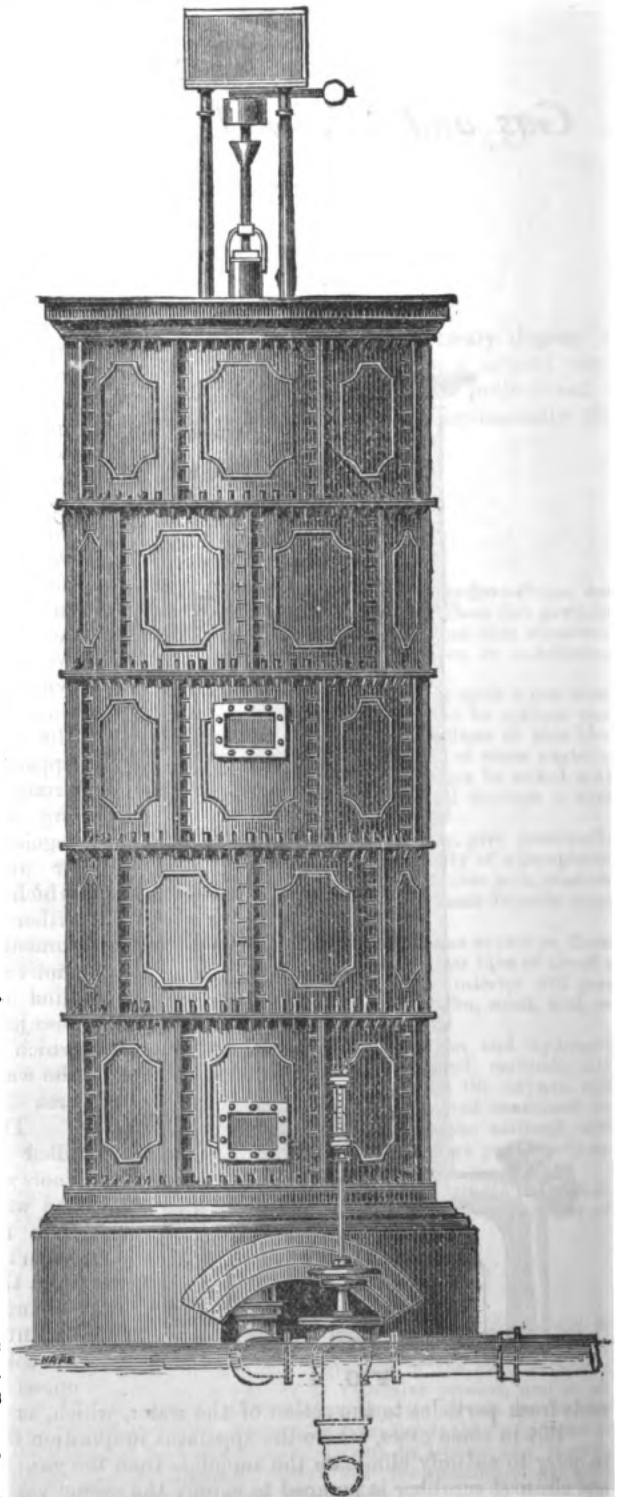

FIG. 3.



## The Washer.

The washer, although not very generally adopted excepting in large works, was one of the earliest appliances used for removing ammonia from gas, the great objection to its use being the amount of back pressure thrown on the retorts. This evil is now overcome by the employment of the Exhauster, and by the several ingenious and careful arrangements in the various designs for the apparatus. Its place, in order, should be before the Scrubber. A very good description of washer is illustrated below, and consists of an oblong box 27'0 feet long by 10'0 feet wide by 1 foot 8 in. deep, formed of cast iron plates bolted and jointed together. A chamber of the same width, but considerably deeper than the body, is fitted to each end of the washer, to one of which is attached the inlet, and to the other the outlet pipe. The main body of the washer is divided into four compartments by perpendicular plates, transversely fixed, securely jointed to the sides and bottom, and extending from the latter to within about four inches of the top.

On the top plates on the inside, and also transversely, serrated curtains are cast, pitched nine inches apart, which dip a little below the surface of the water in the apparatus, the one nearest the inlet end having the greatest dip, and that nearest the outlet the least, the dip of each intermediate curtain diminishing gradually as it is removed from the inlet. A small cylindrical vessel, fitted with adjustable overflow, by which the water level and the pressure can be regulated, is attached to the inlet end of the scrubber; the upper part of this vessel is connected with a pressure gauge.

The action of the apparatus is easily explained; the gas in its passage through the apparatus is broken up into particles as it were and made to pass through the water at every point where it comes in contact with one of the curtains, the ammonia from the gas being taken up by the water, for which it has a great affinity—water absorbing at an ordinary temperature 783 times its own volume of ammonia gas—the liquor from one compartment overflows into that next, commencing at the one nearest the outlet. The liquor in the compartment nearest the inlet, and to which is attached the overflow, is, consequently, of the greatest strength. The method of by-passing the washer is shown on plan.

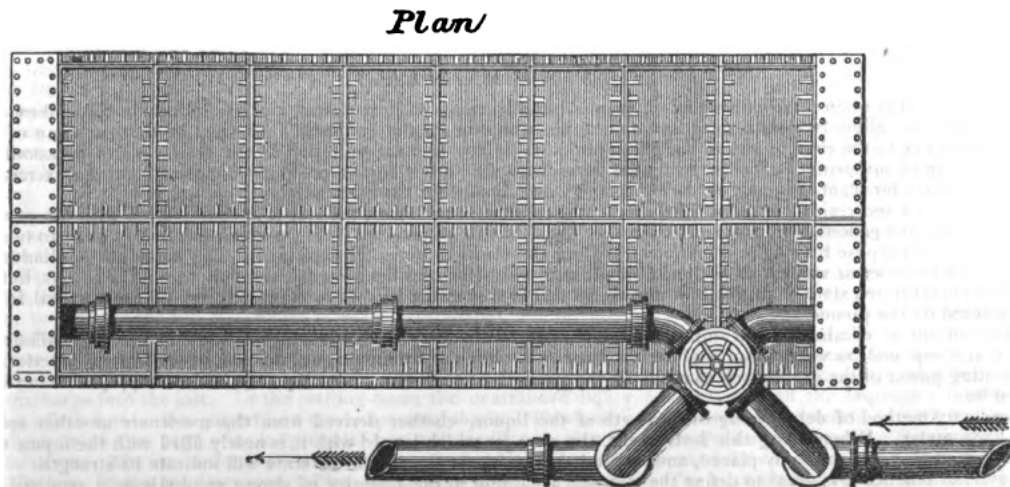
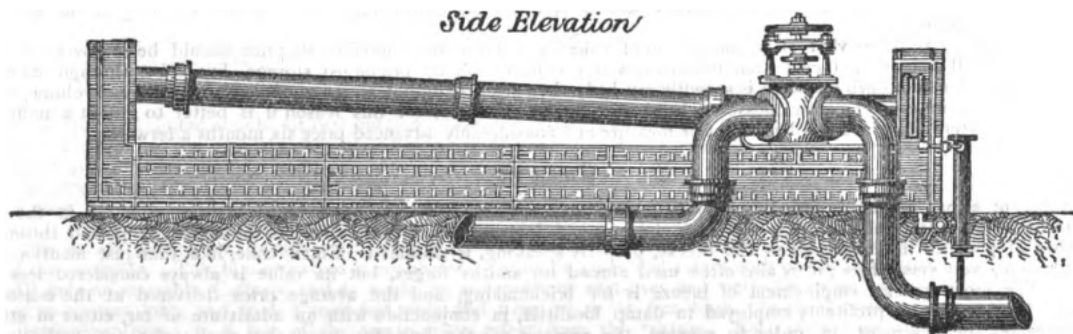

## *Residual Products.*

The returns from the residual products derived from the manufacture of gas is dependent on various circumstances, such as the nature of the coal carbonized, the prices of coal and coke, the description of the neighbourhood where the works are established, whether it be industrial or otherwise, the facilities for disposing of the ammoniacal liquor and tar, and, lastly, the magnitude of the works.

These residuals are coke, breeze, ammoniacal liquor, tar, and, in some few cases, the lime from the purifiers is a source of revenue.

### COKE.

Newcastle coal will yield about 13½ or 14 cwt. of dry coke per ton of coal, but as in the act of quenching a large quantity of water is absorbed by the coke, of necessity, in this state it will weigh considerably more, which is a difficulty attending the method of weighing this residual. Again, in consequence of its variable degree of compactness, coke cannot be measured with anything like accuracy. However, with the view of ascertaining the operations of a works, particularly when of limited capacity, an average sample of coke should be dried, measured, and weighed, which measurement and weight will serve for future operations, whether in defining the quantity used on the works, or sold. It is usually estimated that a ton of coal should yield 36 bushels of coke, which may be taken as a fair average.

In all gas-works where Newcastle or caking coal is employed the resulting coke is always used for heating the furnaces, and it becomes one of the most important questions to properly carbonize the coal with the minimum of coke. It has already been shown that, with a small experimental apparatus, or for the supply of a few lights, if kept constantly going, the coke obtained from the coal carbonized will be sufficient to heat the retort. Therefore, it follows that the same, or superior, results should be obtained with larger apparatus; and this, with few exceptions, is accomplished.

But in commercial operations, as in gas works established to supply a district or town, still more favourable results are expected; and in some instances the coke sold, after furnishing the fuel necessary for heating the retorts, realizes considerably more than the cost of the coal carbonized; although this is very rare, and can only occur when coke is valuable or coal cheap. However, in all works above the most limited kind, the returns from the sales of coke are important. Thus, in a works producing 10,000,000 cubic feet per annum, 35 per cent of the coke produced should be sold. Works of 30,000,000 feet per annum, will sell 50 per cent, and others of 60,000,000 and upwards should sell 70 or 75 per cent of the coke obtained in the process of carbonization, the other 25 or 30 per cent being consumed in heating the retorts. The price realized per ton will be entirely dependent on circumstances, hence the actual returns from this source cannot be estimated; but in all cases where the works are of any magnitude, wherever they may be situated, whether abroad or at home, the sales of the coke should contribute largely towards the cost of the coal carbonized.

Small works, however, producing 1 or 2,000,000 feet per annum, labour under considerable disadvantage in this respect, owing to the fact that their settings require considerably more fuel to carbonize any given quantity of coal than larger ones. Again, as one man has often the whole charge of the works both night and day, in addition to his outdoor duties, he cannot give all the desired attention to the furnaces. Besides, the great irregularities in the demand for gas, which in summer time is not sufficient to keep the retorts continually in operation, when the heats must be maintained although no coke is produced—or in winter, when more retorts are often in action than are really requisite to produce the necessary supply of gas—in both cases loss of fuel is sustained; therefore, these and other circumstances which control very small works prevent them realizing much from their sales of coke, but as works increase in magnitude, as already shown, they possess facilities for improving their position, not only in the sales of coke, but also all the other residuals.

An important point is to prevent an accumulation of coke in a gas works, therefore its price should be so governed as to effect a ready sale. It is well known that coal even deteriorates very considerably by prolonged storage, but coke, through its very friable nature, and its disposition to absorb moisture is speedily crushed, when stacked, diminishing materially from its original volume, and leaving a mass of breeze which in most localities possesses but little value. Therefore, for this reason it is better to sell at a moderate price, as produced, than to store coke, and sell by weight or measure at a considerably advanced price six months afterwards.

### BREEZE.

The breeze of a gas works, is, in all cases, an unavoidable evil, as it is simply produced by the reduction in the weight of coke. In some works, pieces of coke the size of a chestnut and less enter as breeze, whilst in others all is passed through a sieve having meshes of ½ of an inch wide, when the breeze, properly speaking, is obtained. Small coke, like that just mentioned, is well adapted for making very small fires; it is also often used abroad for smiths' forges, but its value is always considered less than the larger coke. The most general employment of breeze is for brickmaking, and the average price delivered at the works is about 3s. per ton. Breeze may be profitably employed in damp localities, in conjunction with an admixture of tar, either in store rooms or other places on the basement, in order to prevent the passage of the humidity from the earth; also for paths in grounds, where gravel is not available.

The average common bulk of stowage coal is 40 cubic feet, and of gas coke about 76 cubic feet per ton.

### AMMONIA.

This residual is too often utterly disregarded, even in establishments of importance, and particularly in those abroad, some of which, producing a hundred million feet per annum, make no return whatever for the ammonia. The fact is, that at some of those works it is allowed to flow away to the river or sea, to the great prejudice of the fish and pollution of the river, besides occasioning repeated complaints from the local authorities—all of which could be avoided with profit to the company concerned, by the exercise of a little care, with but little outlay for plant, and only requiring ordinary intelligence for the manipulation.

Of this impurity and residual about a third exists in the ammoniacal liquor, the rest is in combination with the gas. Newcastle coal gives an average of ten gallons of ammoniacal liquor per ton; but this, as received from the condenser, is too weak to become a commercial article, and for that purpose it must be therefore treated on the works as hereafter explained. The ammonia is eliminated from the gas by means of the scrubber or washer, or both combined; and points for consideration are, not only to purify the gas, but also to retain the impurity in a concentrated state or degree of strength, so that it may either be sold to manufacturers of the residual in question, or may be manufactured on the premises.

For the purpose of eliminating the ammonia from the gas, as already stated, advantage is taken of the great affinity that water possesses for that compound, as water absorbs about 700 times its volume of ammonia gas; but on account of its deteriorating influence on the illuminating power of the gas, as well as reducing the strength of the ammoniacal liquor, a limited supply of water in the operation is indispensable.

The ordinary method of determining the strength of the liquor, whether derived from the condenser or other apparatus, is by the Twaddell hydrometer. When using this instrument, the glass jar which is sold with it is nearly filled with the liquor to be examined, in which the hydrometer is then gently placed, and, when it is steady, the degree on the scale will indicate its strength.

However, in practice it is usual to define the strength according to the quantity of strong sulphuric acid required to neutralize one gallon of the liquor under examination. Thus, if we suppose that not less than ten ounces of acid be necessary for that object, it is then

recognised as "10-ounce liquor, when, as seen in the following table, it would be composed of one thousand parts of water and twenty-five parts of ammonia.

Whether by design or accident, it happens that the ounce strength corresponds with the Twaddel hydrometer; hence 5° Twaddel is 10-ounce strength. They, moreover, correspond in their specific gravity, as represented in the following

TABLE OF THE DEGREES OF TWADDEL'S HYDROMETER, CORRESPONDING WITH THE SPECIFIC GRAVITY, WEIGHT, AND OUNCE STRENGTH.

Degrees of Twaddel.	Specific Gravity, water 1000	Weight per Gallon in lbs.	Ounce Strength.	Degrees of Twaddel.	Specific Gravity, water 1000.	Weight per Gallon in lbs.	Ounce Strength.
½	1002.5	10.025	1	6½	1032	10.325	13
1	1005	10.05	2	7	1035.5	10.35	14
1½	1007.5	10.075	3	7½	1037	10.375	15
2	1010	10.1	4	8	1040	10.4	16
2½	1012.5	10.125	5	8½	1042.5	10.425	17
3	1015	10.15	6	9	1045	10.45	18
3½	1017.5	10.175	7	9½	1047.5	10.475	19
4	1020	10.2	8	10	1050	10.5	20
4½	1022.5	10.225	9	10½	1052.5	10.525	21
5	1025	10.25	10	11	1055	10.55	22
5½	1027.5	10.275	11	11½	1057.5	10.575	23
6	1030	10.3	12	12	1060	10.6	24

As already observed, in gas liquor there is a large quantity of water in combination with a limited quantity of ammonia; and as the whole bulk of the water has to be raised to a certain temperature, in order to expel the ammonia, this fact, together with the expenses of transport, renders it desirable that the liquid should have a certain degree of strength, below which, in some instances, it would not pay for the carriage. The liquor, as ordinarily sold to manufacturers, is required of 8 ounce or 10 ounce strength; which is, however, very rarely obtained from the condenser, and, in many cases, it is delivered from the scrubbers of considerably less strength than this; when under both conditions, it has to be passed again through the scrubber for the purpose of acquiring the proper degree of saturation.

In a gas works where the ammonia is manufactured on the premises, and where there is no consideration of the expense of transport, all resolves itself into the question of the fuel necessary, and when employing breeze, or other fuel of little value, liquor of a less degree of strength than that required for sale and transport may be profitably manipulated, which is one of the advantages of manufacturing the compound in question on the premises. However, as the whole expense of increasing the strength of the ammoniacal liquor consists in pumping it into a tank, and causing it to pass through the scrubber or washer a second time, it is evident that this must be the most economical method of working.

The liquor of gas works, when manufactured on the premises, is generally converted into the sulphate of ammonia, which is recommended on account of the simplicity of the process, the general demand for that compound, and its remunerative price. The following is a description of a large apparatus for the purpose, and the mode of working.

APPARATUS AND METHOD OF MANUFACTURING SULPHATE OF AMMONIA.

1.—The ammoniacal liquor should be first obtained from the scrubber at not less than 8° Twaddel, or about 16-ounce liquor. This may be effected either in the ordinary way of working, or the liquor may be required to pass twice through the scrubber before attaining that degree of strength.

2.—It is afterwards pumped into a cast-iron cistern, well covered in, and at a considerable elevation, where it is allowed to settle; it is then pumped into a higher and smaller cistern, near the still column, and a few feet above it. The cistern is kept full when the still is at work, in order to maintain an uniform head or pressure: for this purpose, the pump is arranged to deliver slightly in excess; this excess flowing off by the overflow pipe into the lower and larger cistern. A float should also be attached for the guidance of the workman. This higher cistern is connected by suitable pipes and valves with one or more stills.

The still column resemble Coffey's, and is made by preference of cast-iron, and perfectly steam tight. It is in form rectangular, from 6 feet to 10 feet long, and from 1 to 2 feet wide, and from 18 to 25 feet high. Internally there is a series of iron shelves 3 feet apart, extending from 4 to 6 feet of the top to about 2 feet from the bottom. Each shelf is separated at one end, alternately, from the external cage by an orifice of about 3 inches wide, and is provided with an edge or border, so that a depth of about 3 inches of liquor is retained by each shelf.

The ammoniacal liquor is admitted at the top of the vessel, and descends in succession over the whole of the shelves to the bottom. The two feet space at the bottom is kept half filled with liquid, and near the bottom of this space, and into the liquid, steam at about 20 lbs. is admitted by a pipe provided with a cock to control the quantity. The steam forces its way through the liquor, and passes upwards between the shelves and over thin surfaces, and in contact with the ammoniacal liquor as it pours over the end of the shelves. In this manner, the ammonia is vaporized, and passes from the still to the saturating vessel.

The saturator is a vessel lined with lead, of from 100 to 200 feet capacity. The form preferred is cylindrical, with flat bottom and hemispherical top, with ample space for expansion in the frame-work of wood, and on the top of the dome is a man hole and door for repairs and cleaning. The pipe from the still enters the side of the saturator, and is formed into a semicircle resting on the bottom and perforated with a number of ½ inch holes. Near to the saturator, and slightly above its level, is the charging box; this being a rectangular wooden vessel lined with lead, into which is poured the acid diluted with the requisite quantity of water, which is conveyed by a sealed pipe into the saturator.

A pipe of suitable dimension leads from the top of the saturator to the condenser, through which the noxious gases are passed. The condensed liquid is inodorous and innocuous, and is separated from the gas in a separating box.

The liquid may be run into the ash-pits, where it will be evaporated, and the noxious gases conveyed by a suitable pipe into the main flue or chimney stack where they are burnt. This process is, however, attended with the loss of the sulphur.

The saturator has near the bottom a suitable pipe for discharging the contents, when ready, into a rectangular wooden vessel lined with lead, called the settling basin, which is placed at such a level, in relation to the saturator and the evaporating basin, as to receive from the first and discharge into the last. In the settling basin the neutralized liquor remains with all the impurities that will fall by gravitation, and, this effected, it is then passed into the evaporating basin. These are generally made of wood, lined with lead, rectangular in form, and about 12 or 16 feet high. A long coil of one-inch lead steam pipe is laid on the bottom, having a tap on the outlet, and supplied with 30 lb. steam. The steam used for the boiling down of the salts is generally partially condensed, and again used as steam boiler feed. The salts form during the process of boiling, as the surplus water evaporates. The salts are then ladled from these basins into the washing basins, and eventually left to dry, and stored.

The simplest manner of treating the ammoniacal liquor, and one adapted for small works, is to have merely a boiler and evaporating pan.

With this, as in the preceding, the liquor is pumped into a tank, placed at a somewhat higher elevation than the boiler, in order that no liquor may flow by gravitation from the former to the latter. In this tank the tar is deposited, which can be drawn off as occasion may require, and the liquor flows off from the upper part. A boiler, either cylindrical or otherwise, of the simplest description, having a curved pipe or neck at the top, serves as the distillatory apparatus, and is in communication with, and attached to, the evaporating pan. The evaporating pan is formed of cast iron of about half an inch thick, and hemispherical in shape, lined throughout with stout sheet lead in such a manner that the acid with which it is charged cannot penetrate to the iron. This pan is set in brickwork, and rather more than half its area is covered with planking, from the extreme edge of which near the centre descends a division, or diaphragm, lined with lead, extending to within a few inches of the bottom of the pan. A pipe from the curved pipe of the boiler is connected to a lead pipe which descends into the evaporating pan, and at the end of the lead pipe is attached a leaden perforated cylinder for the purpose of distributing the gases among the liquor. The boiler being charged with the liquor from the tank, and the evaporating tank supplied to the necessary height with dilute acid, and the pipes of communication between the two vessels being tight, fire is applied to the boiler, when after a short time the ammoniacal gas passes from the boiler into the evaporating pan, and mingling with the acid, expels noxious gases, which are conveyed by a pipe for that purpose in the cover to a neighbouring chimney. As the acid becomes partially neutralized, and the crystals of sulphate of ammonia formed, a portion of fresh acid is added, until the ammonia is expelled from the boiler, and the operation is concluded. The fire may then be withdrawn, and the liquor in the boiler replaced with fresh liquor ready for another operation. In the meantime the crystals of sulphate of ammonia are removed by a wooden rake from the open part of the evaporating tank, and are left to drain previously to being stored; the remaining liquor being left for another operation.

The production of sulphate varies according to the quality of the coal and the mode of operating; but the average may be taken at 22 lbs for each ton of coal carbonized, which, after deducting the expenses of acid, fuel, and labour, will leave a profit from this source of from 2s. 3d. to 2s. 6d. per ton of coal, supposing the selling price of the sulphate to be £16 per ton. The importance of economy in this part of a gas works is therefore obvious, and all establishments of 20,000,000 feet per annum and upwards should profit by it.

The price paid by manufacturers averages 7s. per butt of 108 gallons of 8 or 10-ounce strength, which will yield about one shilling per ton of coals carbonized. The vast difference between manufacturing on the premises and selling the liquor is evident; in addition to this drawback of price, there are many works which are entirely out of the reach of manufacturers, and therefore, if not manufactured on the premises, the ammonia must be lost.

#### A NEW AND ECONOMICAL METHOD FOR EFFECTING THE EXTRICATION AND CONDENSATION OF AMMONIA FROM GAS.

BY FREDERICK BRABY, F.G.S.

"It is but a very few years since, that the various products obtained in the manufacture of coal gas were not merely a drug in the market, but proved an absolute nuisance to the manufacturer and the general public. Now, however, in consequence of the many applications which it has been discovered they may be put to, especially the ammoniacal liquor, which is used for the reduction of the ammoniacal salts, great competition exists for their acquisition. Practically, the tar and gas liquor trade is in the hands of a few parties jealously desiring to exclude outsiders, who thus find it extremely difficult, and often absolutely impossible, to obtain even a few thousand gallons.

"The strength of gas liquor is commonly specified in the various tenders at technically 6-oz. The prefix denoting the number of ounces refers to each gallon of the liquor, and does not signify the number of ounces of the ammonia that are present, but the number of ounces of sulphuric acid which would be requisite to neutralize the ammonia; consequently, a butt of 108 gallons of 6-oz. liquor implies that 40 lbs. of sulphuric acid are required to saturate the whole quantity. Now it is found in practice that if we divide the quantity of sulphuric acid required by 3, we shall get at the quantity of ammonia actually present. This result closely agrees with theory, the equivalent of dry ammonia being 17, and that of monohydrated sulphuric acid (oil of vitriol) being 49; the proportion is very nearly 1 to 3. It follows, therefore, that as 40 lbs. of sulphuric acid are required to saturate a butt of 6-oz. liquor, so one-third of this, or little more than 13 lbs. of ammonia, are contained in this immense quantity of liquid and commercial product, weighing, as it does in the aggregate, no less than 1107 lbs.

"On referring to the ordinary commercial standard—viz. of 6 oz. per gallon—6 oz. of sulphuric acid divided by 3 gives 2 oz. of the ammonia as the entire quantity present. Now a gallon of gas liquor weighs 10 lbs., and if this be multiplied by 16, to reduce them to ounces, we have a total quantity of 160 oz. containing only 2 oz. of real ammonia, or 1 oz. to 80 oz. of water. The result of this is practically to prohibit the transport of the gas liquor over any but moderate distances, because in its present form, for every ton of real ammonia carried by barge, tank, cart, &c., no less than 80 tons of water must be carried for no other purpose but as a solvent. It must not be inferred, however, that the whole of these 80 tons of water is waste carriage. Ammonia in a free state cannot be carried, except when dissolved in a certain quantity of water. It would not be judicious to concentrate the ammonia to a higher degree than 900, since, if in the course of carriage it were subject to any degree of heat, the water at an elevated temperature would disengage some of the ammonia held in solution, and such a disengagement of ammonia might be attended with dangerous results.

"A very useful and safe solution for all practical purposes of transit, would be about one part by weight of ammonia to four parts of water. This would reduce the present cost of carriage no less than twenty times, or in other words, what at present costs £20 in carriage would be reduced to twenty shillings. This reduction would enable it to be carried by rail in particular, in barrels and in tank trucks.

"In order to effect this desirable object, I have recently, in conjuncture with Mr. Baggs, secured a patent for effecting the necessary concentration of ammonia by certain novel means, which promise in practice to prove far more rapid and economical than any hitherto employed. The process may be briefly described as follows:—To the common gas liquor a certain quantity of slacked lime is added. The liquor thus treated is placed in a boiler or still, containing from 400 to 500 gallons. The whole is then heated and maintained at a temperature of from 100° to 200° Fahr., the liquor being slowly but constantly stirred by means of an internal agitator, the spindle of which passes through a stuffing box in the boiler. By these means the ammonia is expelled, and can be absorbed by water contained in a vessel for that purpose."

NOTE.—This is the method frequently employed in distilling the ammoniacal liquor, and is preferable to all others on account of all the various compounds of ammonia being operated upon; but the drawback consists in the incrustation of lime found within the boiler, and the trouble of removing and changing the lime repeatedly.

#### AMMONIACAL WATER.

Ammoniacal water is generally used as a stimulant to young grass, barley, and oats. The best mode of application is to reduce its strength by adding an equal bulk of water, and by means of an ordinary liquid manure cart it is then passed over the young sprouting crop in a gentle shower. This method, however, is the preferable one only when likely to be followed by rain.

Another method, more frequently adopted as being the most convenient, is to saturate a large heap of mould with the liquid in its undiluted state, mixing the mass thoroughly, and stowing it closely together, and at convenience using it as a "top dressing." This is stated to be very efficacious, especially on grass crops, and it is much safer than the ordinary sulphate of ammonia, as generally applied.

## TAR.

The next residual, tar, is an indispensable production in the manufacture of gas; and, as shown hereafter, it is considered by Mr. Lewis Thompson of paramount importance in the purification. But against this advantage, which can only apply to a limited quantity, it should be borne in mind that any excessive yield of tar is equivalent to a loss of gas of the same weight as that of the extra tar produced; and, as already observed, low heat and excessive charges resolve the hydrocarbons of the coal into tar, instead of gas.

Tar for a number of years was a drug in gas works, and was employed as a luting instead of water in the holder tanks, and, like the ammoniacal liquor even at the present day, its value is not appreciated, for in many instances it is permitted to run to waste. Among the first applications of tar was the attempt to convert it into illuminating gas, which, on first consideration, on account of the weight of the hydrocarbons in combination with it, would appear both practicable and profitable. This, however, has been proved by innumerable experiments, entailing a great expenditure of money, together with labour and disappointment, to be quite impracticable; hence, the endeavours of the gas manufacturer should be directed to the means of avoiding any unnecessary production of tar, as, once generated, it cannot be advantageously converted into gas.

Of late years, the uses of tar have increased in a remarkable manner, particularly for manufacturing purposes, in some of which operations the chimeras of the alchemists may be said to be realized, as tar, in its crude state, is of considerably less value than any metal, and yet some of the products obtained from it are, weight for weight, equally valuable as gold itself. For these reasons, the manufacturers are enabled to purchase the tar at a price far exceeding that of former years, and when the works are established in the neighbourhood of a manufacturer, or having facilities of transport, the best method in most cases is to sell it direct.

The ordinary uses of the residual in question are for preserving timber, such as fences or palings of grounds, for coating iron, to prevent it from rusting, or coating walls to prevent the humidity exuding. It is also employed, intermixed with breeze, for forming footpaths, or for placing beneath floorings on the ground floor, in order to avoid damp, and it is very extensively employed in the Metropolis for footways. This, in the most effective way, is accomplished by levelling the ground, about one inch lower than the desired level of the footway, and this done, a layer of pebbles of about the size of a chestnut, and smaller, previously saturated with tar, is placed over the whole surface a thickness somewhat less than an inch, and on this is laid a coating of gravel, its largest pebbles not exceeding one quarter of an inch in diameter, which gravel is saturated with hot tar just previous to being placed. This is then levelled and covered with dry sand, when, by means of a heavy garden roller, the whole is rendered smooth and even, and makes an admirable footway of great durability, at a moderate cost. The *modus operandi* is given more in detail hereafter by the late Mr. Methvin.

But when there is no demand for the tar, and when the locality where it is produced does not offer facilities for its economical transport, under these circumstances it may be employed with advantage for heating the retorts. For this object, two different systems are employed. In one of these a small hole is made immediately over the door of the furnace, through which is passed a small gutter, of such a length that the tar will flow on to the ignited fuel in the furnace. The tar is conveyed by a service pipe, either direct from the hydraulic main, or from a tank arranged especially, and at the end of the supply pipe is a small tap where the quantity of tar is controlled. Beneath this tap is a funnel affixed to the pipe which conveys the tar on to the gutter. The tar is allowed to flow in a stream of about the tenth of an inch in diameter, and falling direct on the red hot coke within the furnace, inflames and aids in heating the retorts. According to the other method, no coke whatever is used in the furnaces, the retorts being heated by the tar alone, which system is often employed in old settings where one or more retorts are useless. To make the change from coke to tar, the first thing to be done is to shut the damper, remove the furnace bars, and take the door off its hinges. Then fill the ash pan and furnace to the level of the bottom of the door opening with old lime, which cover over with a layer of breeze of about two inches thick. The opening of the door is then bricked up a thickness of 9 inches, but leaving two orifices about 2½ inches square in the centre of the door space, the one about 5 inches above the other. In the upper orifice is placed a gutter of angle iron, or, better still, of fire tile, of about 16 inches long, one end of which projects about 3 inches outside the wall, in order to receive the tar as it drops and convey it into the furnace, the other end of the gutter protruding about 4 inches into the furnace. Everything being prepared beforehand, all this alteration can be effected within an hour without materially reducing the temperature of the setting. Now if the tar be arranged as already indicated, and allowed to flow into the furnace a bright flame will be formed at the end of the gutter, and a portion of tar will constantly drop therefrom; which tar falling opposite to the lower orifice, produces another flame, in addition to the incandescent carbon resulting from the dropping tar. The operation is facilitated by supplying a very small quantity of water separately from the tar, which should fall in drops of about one hundred per minute; this prevents incrustation in the gutter, and avoids smoke. By these means, a setting of six single retorts can be effectually and regularly heated during any period, without requiring any attention beyond the proper adjustment of the supply of tar and water, and removing the ashes, once a day, which collect in front of the lower orifice, which, however, do not exceed a pound in weight.

Tar acts as a flux on brick-work; therefore, when furnaces are constructed expressly for being heated by it, the walls should be wider apart, and the arches, when used, higher than when coke is employed, in order to keep the brick-work out of the destructive influence of the tar.

## ON THE MANUFACTURE OF TAR PAVEMENT BY MR. METHVIN.

"The pavement may be made of the ordinary cinder dirt produced in gas works, or of shingle, or a mixture of both. The material is placed in heaps like ballast, and is intermixed with some hot tar. In practice, I make a small fire of coke on the ground, and cover it with cinder dirt or shingle. When this layer is hot, another is added, and so on in succession, until a heap large enough has been provided. The tar is now boiled in an iron vessel, and taken when hot, and mixed with the hot material forming the heap already described, in quantities of two bushels at a time, in about the proportion of one gallon to every bushel of cinder dirt, and slightly less than a gallon for the gravel. It is then turned over with the shovel until every part of the material has got a covering of the tar. Then I pass the whole through a sieve, having ¾ inch mesh, and part of it through another having a ¼ inch mesh, and put each in separate heaps until they may be required, as the material may be kept for months before being laid down.

"Before the pavement is laid an edging should be provided about two inches thick, and projecting two inches above the surface of the ground to be covered, which should be tolerably even. It is advisable to have the ground next the curb well rammed before the pavement is laid, otherwise there will be an unseemly hollow next the curb. In laying, the rough stuff is put down first, and rolled tolerably even, when the smaller kind is placed, and the whole is raked level. This done, a portion of gravel is sifted through a sieve with ½ inch meshes, and a little fine white shingle or Derbyshire spar is sprinkled on the top. The whole must now be well rolled. The best roller is a water ballast roller, which at first is used without ballast, and well wetted to prevent adhesion of the material; and when the pavement is slightly consolidated, the full weight should be applied. For heavy cart traffic, the material should be made of shingle only, heated and mixed as above, and well rolled.

"Both descriptions of pavement are laid best and most readily in warm weather, and should be rolled when the sun has thoroughly warmed it. Those parts in angles should be well rammed, and trimmed off with a light shovel.

"Though apparently a simple process, there is a little difficulty in ascertaining the proportion of tar to gravel or cinder dirt, but a little experience will be sufficient to overcome this difficulty.

"I cannot recommend this pavement too much, as it is cheap, wears well, and can be easily repaired. The colour, which can never be made equal to York flagging, and the smell for some time after it is laid, are the only objections to its use. It

can be laid with a good profit in any district at 1s. 4d. per square yard, and besides being a boon to the public, is a great advantage to gas companies, being a remunerative outlet for their tar, which is otherwise sold at a low price to distant distillers.

"Since writing the above, I hear that it is proposed to pave the streets of London with stone laid in asphalt instead of lime grout, which is a more systematic application of the above described plan, whether employed to fill the interstices of paved stones, or mixed with the material as described for the tar by being boiled, becomes in both cases an elastic asphalt."

#### TAR AS A PURIFYING AGENT.

It may perhaps, excite a little surprise when, upon examining into the nature and production of coal tar, we come to treat of it first as a purifying agent. Nevertheless, such it really is, and without this or some similarly constituted substance there can be no doubt in the world that the purification of coal gas would be almost an utter impossibility. If coal tar be dissolved in sulphuric ether, and left for several weeks in a state of perfect repose, it will be found that a very large amount of extremely divided carbon or charcoal has settled to the bottom of the vessel, and the precipitation of this carbon, in union with a portion of oily matter, may be at once effected by adding a little strong sulphuric acid to common coal tar. Hence we find that tar consists not only of several compounds of a fluid kind, as usually represented, but contains also a large proportion of solid carbon or soot, which soot or carbon has been removed from mechanical admixture with the gas by the peculiar attractive and condensing power of the various hydrocarbon compounds. As it is well known that soot has a great affinity for hydrocarbon vapors, it is unnecessary to say that these must also have a like affinity for soot; and, therefore, the minute and almost atomically divided particles of carbon which arise during the destructive distillation of coal, being in immediate contact with hydrocarbon matter, combine with, and are condensed with this vapour into the black viscid fluid called tar. Nor would it, as we have said, be possible to separate this carbon from the gas, unless some such arrangement existed as that by which the tarry vapors and the carbonaceous particles are first brought into mechanical admixture, and subsequently condensed together into one fluid. If, therefore, it were possible to make gas without the production of condensible hydrocarbon compounds, the subsequent difficulty caused by the accumulation of carbonaceous particles would oppose an insurmountable barrier to success. And, indeed, this is actually one of the impediments felt, and most seriously felt, in all the various projects for converting coal tar into gas, whether this is sought to be done upon the tar in its incipient and nascent state, or upon the commercial article after its production and condensation. In both cases, the most obstinate deposits of soot are observed to take place in the upright pipes, the hydraulic mains, the condensers, or even in the purifiers, and sometimes in all of these. This soot has no affinity for water or watery vapor, which indeed repels it; consequently, steam is of no use in effecting its condensation; and it is so minutely divided, and so little ponderous, that the mere current of the gas is sufficient, by its motion, to carry it occasionally even into the street mains. Naphtha, turpentine, and electro-negative vapors generally are the only agents capable of combining with it; electro-positive vapors, as that of water, repel it. And this brings us back to our previous assertion, that coal tar, or rather the hydrocarbon compounds contained in coal tar, exercise an important and indispensable function towards the purification of gas. Those gas engineers, therefore, who seek the destruction of these hydrocarbons, are really aiming a blow at a good friend; and few who have tried to make gas from coal tar alone, or from coal tar and steam, will hesitate to admit the difficulty which ultimately subdued all their enthusiasm, was precisely the want of a practical means of condensing or removing from the gas the finely divided soot or carbon given off in the process, and which, by the common method, is so simply and effectually done, that its very existence has hitherto escaped general observation.—L. THOMPSON.

#### TAR.

Tar, when properly used, is an excellent manure for potatoes, etc., and is also a preventative of disease in the crops; the idea that potatoes, when thus manured, will have a tarry flavor is erroneous, and has as much reason for it as that they will taste of any other manure. In Scotland, the method of using it as follows: whilst storing up manure in the dung yard, a layer of common farm yard manure is deposited, of about one foot deep, and when levelled, sprinkled over with a good coating of tar; this is covered with another layer of manure, and tar similarly applied until the heap is made up. The decomposition of the heap is not retarded in any way, but a singular change in the nature of the tar itself takes place, its oily character shortly disappears by its absorption in the manure, and a carbonaceous powder remains in its place. Manure thus prepared has invariably been found to produce much richer cereal and green crops than ordinary, and abundantly repays the trouble and cost.

#### GAS REFUSE AS MANURE.

"Gas lime has been used very largely as manure, and the agricultural estimate of its value may be learned from the fact, that in large towns it can be given away, while in the strictly rural districts it fetches from about a third to a fifth of the cost of the lime.

"When applied in too large quantity, gas lime does considerably injury; in fact, it is capable of destroying all vegetation for years if applied too freely; hence its use under garden paths and other situations where prevention of the growth of weeds is desired. But there are certain cases where benefit has arisen from the use of gas lime, and where its judicious employment has yielded a profit. I have met with cases of red soils where an application of 5 or 6 cwt. an acre has been found to benefit corn.

"Such cases are easily explained, Soluble sulphides would be decomposed by the oxide of iron of the soil, and would yield harmless sulphur, when oxidized by the air, instead of hurtful compounds, such as would come into contact with the roots of plants in the absence of the oxide of iron, or when the refuse lime was applied in excessive quantity. The truth is, gas lime yields a large proportion of soluble lime salts, and hence requires to be applied with judgment. If 4 or 5 cwt. were applied every other year, I do not think the application could be otherwise than beneficial.

"Mixing gas lime with compost is worse than useless. The soluble lime salts are not converted into insoluble ones in an entire twelvemonth, and any little ammonia which may happen to be formed in the compost heap is set free by the caustic lime, which always exists in a large proportion. I once saw gas lime mixed with fold dung in a field, when the evolved ammonia could be smelt about a hundred yards away from the heap, and a fine tree near it was entirely destroyed.

"SPENT OXIDE.—This is now used for the manufacture of sulphuric acid, but it was tried as manure with disastrous effects. Where it was applied freely it destroyed all existing vegetation, and nothing would grow upon the ground for years. At length the destructive power was itself destroyed, and the land resumed its fertility.

"AMMONIACAL LIQUOR.—It is not worth a farmer's while to buy this in large towns, owing to its value for making ammoniacal salts, and the large quantity of useless water which he is obliged to buy and carry to obtain the manurial compounds. It may be obtained from small country works, and from private works where gas is made for domestic use, &c., and then it forms a good manure, especially for grass. It should be diluted with at least three times its own bulk of water, before it is applied to the land. Should grass at any time be a little browned by the application it soon recovers, and grows vigorously."—BOWDITCH'S *Analysis of Gas*.

[F]

## P U R I F I E R S ,

MANUFACTURED AND SUPPLIED BY

GEORGE BOWER,

*Gas and Water Engineer and Contractor, St. Neot's, Hunts.*

## WET AND DRY LIME, AND OXIDE OF IRON PURIFICATION.

The ammonia being eliminated, there still remains the carbonic acid, sulphuretted hydrogen, and other sulphur compounds, which it is necessary to remove before the gas is sufficiently pure to be delivered to the public.

The most perfect method of eliminating these impurities is with a solution of lime, or, as generally called, the "cream of lime," which possesses the quality of absorbing all the noxious compounds. But against this advantage the nuisance arising from the odour of the foul material, technically termed "blue billy," is so intolerable as to prevent this system being adopted at gasworks in the neighbourhood of any city or town; and, although the emanations might be conveyed by mechanical appliances into a chimney shaft and there burnt or otherwise disposed of, hitherto this has not been adopted. However, for the reasons mentioned, the "wet lime" system of purification is very seldom used.

The next system of purification is the "dry lime," so called in contradistinction to the "wet lime" process. When adopting this the quick lime is slaked with water, which being thoroughly effected, it is then well moistened to such a degree that on taking a portion and pressing it in the hand, the lime has almost a doughy consistency, similar indeed to snow, which may be compressed into a mass and readily detached in morsels. Moreover, if it were not for the obstruction to the passage of the gas occasioned by the lime adhering together, the greater the quantity of water mixed with the lime, the nearer it would approach to the wet lime process, and the more perfect would be its action. The dry slaked lime, or the simple hydrate of lime, is next to useless for the purpose of purifying gas, as when in that state, even after prolonged use, it is hardly discoloured; whereas, when properly moistened, the impurities are readily absorbed, as demonstrated, by the colour of the foul material. However, it should be remembered that this foul material, even when of a deep green colour, still possesses the property of absorbing the most troublesome of the sulphur compounds, other than sulphuretted hydrogen. Therefore when efficiency and economy are duly considered, the foul lime should be retained in action long after it is discoloured; but for this object a sufficient number of purifiers, or extent of purifying surface, is necessary.

When employing the moistened hydrate of lime, it is placed on the grids of the purifier to a depth of about three inches, and the gas in its passage through the lime deposits its impurities. For this object the gas first enters the purifier containing the foulest material, from there it passes to another where the lime is cleaner, and thence to the purifier containing the freshest lime, where the process is completed. Attempts have been made to revive the lime as it comes from the dry lime purifiers, by burning and exposing it to the action of the atmosphere, but as a matter of economy without success.

It should, however, be observed that at the Beckton gas-works, the largest in the world, the system of purification is reversed; for there the foul gas first enters a clean dry lime purifier in order to remove the carbonic acid from the gas, a necessary process for its further purification. The gas then passes into a purifier charged with the green foul lime, or hydrosulphate of lime, where the bisulphide of carbon is absorbed, and the sulphuretted hydrogen is afterwards eliminated by oxide of iron. However, the system first mentioned of passing the foul gas into the foulest purifier is almost universally adopted.

The next purifying agent which is most extensively used is the oxide of iron, but this is only serviceable in eliminating the sulphuretted hydrogen, and has no effect whatever on the other compounds, except so far as the water in combination with it may absorb any traces of ammonia.

There are various descriptions of oxide used for purifying, some of which are intermixed with sawdust ready for use. Others are natural oxides, that is, oxides intermixed with earthy and fibrous material as taken from the earth, which are of sufficiently porous a nature as not to require any admixture. The commercial oxide of iron is also sometimes employed, which is intermixed with three or four times its bulk of sawdust, so as to render it sufficiently permeable for the gas. But according to the opinion of Mr. Lewis Thompson, from some cause not understood, all commercial oxides are not suitable for the object, and it is only on submitting them to the proper test that their power for absorbing sulphuretted hydrogen can be ascertained. This material, like the dry lime, is well moistened before being placed in the purifiers, where it is always laid of a much greater thickness than the lime, averaging from six to eight inches, and in some purifiers of large area it is often laid a thickness of ten or twelve inches. In short, as long as the purifying material does not cause any obstruction to the passage of the gas or back pressure, the thicker the layer the better, as by these means the operation of changing the purifiers is rendered less frequent than with thinner layers; consequently, the labour is diminished, and the chances of the admixture of atmospheric air with the gas reduced.

GEORGE BOWER, ST. NEOTS, HUNTINGDONSHIRE.

There are numerous firms which furnish different classes of oxide, varying in price from about £2 to £5 per ton, and in the choice of this material the gas manager should be guided by the experience of friends, or the description used by the larger companies; although, concerning this, it should be remarked that the practice of some of the companies of magnitude, even in the metropolis, is variable, as in one instance a company pays to the oxide of iron contractor a specified sum per million feet purified, whilst in other cases the oxide is furnished gratuitously on the condition that it may be removed when saturated with sulphur, by the party supplying, and in one case the foul oxide is sold to a contractor. Hence, with these different methods, it is obvious that only when the company purchases the oxide, the manager has the choice of the most suitable material.

When the oxide in the last purifier of the set is saturated with sulphur, it is then removed and conveyed to a floor appropriated solely to that purpose, where it is laid a thickness of twelve or fifteen inches in the order that it is received from the purifiers: that is, the oxide which has undergone the process of revivification is kept the most distant from that newly delivered from the purifiers. With new oxide the action of revivification is so violent that the material will heat to an alarming extent, and it is said that at times it inflames, when the surrounding neighbourhood must be rendered insupportable by the fumes of sulphur. For this reason it is usual to intermix a small portion of the new with the old material, as occasion may require, as by these means the chances of combustion are much diminished, if not altogether avoided.

After the foul oxide is left on the reviving floor for two or three days it has a tendency to cohere or cement together, when it becomes necessary to break it up into small pieces, in order that the atmospheric air may act upon the mass; which operation is frequently repeated until, at the end of a few weeks, the oxide becomes revived and can be again employed for the purpose of purification, which is known by the material assuming, or approaching, its original colour. The chemical action of the revivification is explained on page 39.

Good oxide of iron may be employed in the purifiers, and again revived, as many as thirty or forty times, and will absorb as much as 50 per cent of its weight in sulphur.

To ensure the purity of the gas, it should be tested at the various purifiers at intervals, by which means the knowledge is acquired when it will be necessary to "change the purifiers," or, more properly speaking, to replace the purifier having the foulest material for another charged with fresh oxide or lime. The method of preparing the various tests, and the manner of applying them, will be found on page 21.

From what has been stated, it is obvious that to remove the carbonic acid lime is indispensable; but in some works, rather than resort to the use of this, the pernicious effects of the impurity in question, namely, the deterioration of the gas, is counteracted by the use of a certain per centage of cannel coal. The motive for this is not clear, but it may be due to some sanitary restrictions, or other causes, which prevent the company adopting the best and most economical system of manufacturing gas.

There are few questions connected with gas lighting where there is such a diversity of opinion as in the purification; for, simple as the operation must appear, yet we find in the various parts of the country each manager has his peculiar method, some using oxide alone, whilst others never admit that material into their works; and others, again, employ a combination of the two materials, which, under ordinary circumstances, is not only the most effective, but the most economical.

This diversity of methods of purifying may, however, in some measure be due to local circumstances, to the cost of lime, or, perhaps, the difficulty of obtaining it at any price; or the position of the works, which may be situated in a neighbourhood boasting of a sanitary inspector, who strains every energy to display his utility, when probably the gas works may engage his particular attention. These, and numerous other reasons, may compel a gas manager to adopt a system of purification in opposition to his own judgment; but, generally, the best and most economical method of purifying gas, after passing the scrubber or washer, is by means of oxide of iron, to remove the sulphuretted hydrogen, and terminated by dry lime, to take out the carbonic acid.

According to general experience, a bushel of quick lime, where this alone is used, and reduced to hydrate, is sufficient to purify the gas obtained from one ton of coal. By the wet lime process, the quantity of lime required is considerably less than this.

SIZES AND PRICES OF COMBINED PURIFYING APPARATUS. (See page 51.)

Number of Combined Apparatus.	Reference to number of Specification for description.	Number of Lights suitable for.	Size of connecting pipe.	Approximate number of cubic feet of Gas will purify by means of lime 2½ in. deep.	Weight of Cast Iron.			Weight of Wrought Iron.			External Dimensions.			Price, delivered at the Docks in London, Liverpool, or Hull.		
	No.				bore in inches.	cwt.	qrs.	lbs.	cwt.	qrs.	lbs.	length, ft.	breadth, ft.	height, ft.	£	s.
0	0	8	1½	500	3	0	0	—	—	—	2	by 1½	by 2½			
1	2	25	2	2,000	10	0	0	—	2	0	2½	by 2	by 2½			
2	4	50	2	4,000	13	1	14	—	2	14	4	by 2½	by 2½			
3	6	100	2	9,000	20	2	0	1	0	0	4½	by 4	by 2½			
4	8	300	3	20,000	37	0	0	1	2	0	6	by 5½	by 3½			
5	10	500	3	33,000	48	2	0	3	0	0	7½	by 6	by 3½			
5 a	10 a	500	3	33,000	52	0	0	4	0	0	7½	by 6	by 3½			
6	11	800	4	57,000	66	0	0	5	0	0	8	by 7½	by 3½			



## THE PATENT COMBINED PURIFYING APPARATUS.

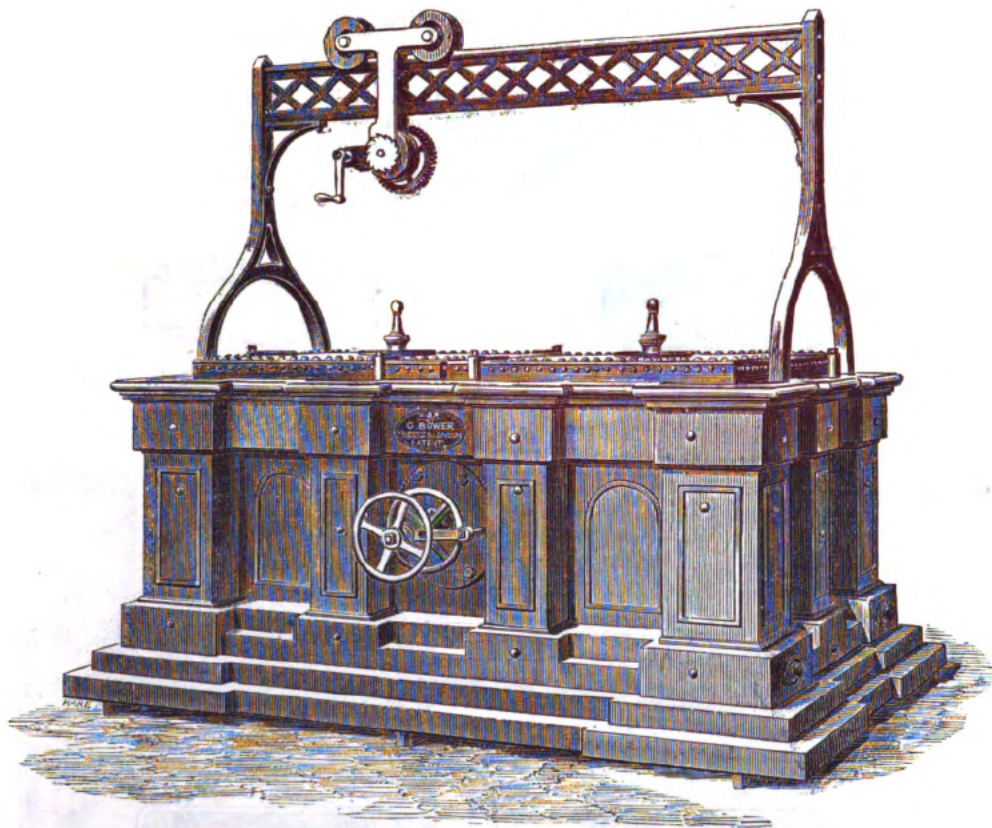

### COMBINED PURIFYING APPARATUS, WITH TWO PURIFIERS, SUITABLE FOR WORKS REQUIRING FROM 400 TO 800 BURNERS.

The above Apparatus combines in one, an Air Condenser, Washer, two Dry Lime Purifiers, and Centre Change Valve, with connections and Lifting Gear for lids.

The Condenser is formed by the pilasters on the sides, the gas being caused to traverse the whole in succession by means of suitable internal divisions; access may be had to the interior by screw plugs, one of which is placed over each pilaster or condensing pipe, and also by small hand holes placed at each end of the base; the washer is arranged within, and forms part of the inlet box or compartment which is situated at the opposite side of the apparatus as shown. The interior is divided by a partition into two compartments, so as to form two separate and independent Dry Lime Purifiers; each purifier is provided with perforated sieves either of wood or wicker work, resting on ledges cast on the sides, and on bearers of wrought T iron; the covers are of strong plate iron, with frames of angle iron, and are fitted with air plugs, turn-buckles, or keeps for holding them down, and eyes for attaching to the lifting gear.

The Centre Valve forms part of a box or cast iron case bolted against the sides of the Purifiers, in which are also arranged the compartments or divisions necessary for connecting the various parts with the centre valve; its position is indicated by the hand wheels shown as projecting from the front side. The valve itself is of a peculiar construction, being a conical case formed in the interior of the box above referred to, and which is furnished with a plug fitted and ground in tight; the spindle of this valve passes through a lid and stuffing box, bolted on to the outer case, and is fitted at the extremity with a hand wheel for the purpose of turning the plug round when required; in order, however, to keep the plug tight to its face, and at the same time, enable it to be turned easily, the valve spindle is made to pass through a hollow screw, fixed in a cross piece attached to the lid by two short pillars, on one end of which screw is a second hand wheel fitted; by means of this, the plug may be slightly eased or drawn from its face until adjusted to its proper position, and then tightened on its face again.

The Lifting Carriage needs no explanation, as a reference to the engraving will be sufficient to enable its construction to be understood; on the lower pulley is coiled a chain, to be attached to the eyes on the lids, when they are required to be lifted off or replaced. The condenser, base, and washer, are each provided with an over-flow pipe, which are carried into a dip cistern so as to seal them; another pipe leads from the dip cistern to the tar-well.

The operation of this Apparatus may be explained as follows:—the crude gas as evolved in the retort

is brought direct from the hydraulic main into the condenser, where it passes up and down the whole of the pilasters or compartments in succession, for the purpose of separating tar, ammonia, etc., by condensation; from thence it passes into the washer, where it deposits any remnant of these impurities not previously condensed; it is then conducted into the centre valve, and by its means is transmitted through one or both of the Purifiers in succession, the sieves of which are covered with slaked lime or other purifying material to the depth of from  $1\frac{1}{2}$  inches to  $2\frac{1}{2}$  inches, for removing the sulphuretted hydrogen and carbonic acid; the gas is then conducted to the station meter or gas-holder, ready for use.

The engravings below represent the type of Oblong Purifiers, and the mode of connecting them. They are especially adapted for works where only two Purifiers are used. Each Purifier is separated in the middle by a division plate, making, in fact, four vessels, connected with inlet and outlet pipes and by-pass valves in such a manner that the gas is made to pass up through the purifying material in one compartment, descending through that in the other. By means of the valves one Purifier may be kept in action whilst the other is by-passed for changing the lime or purifying material. Or, both Purifiers may be in work at the same time, if desired.

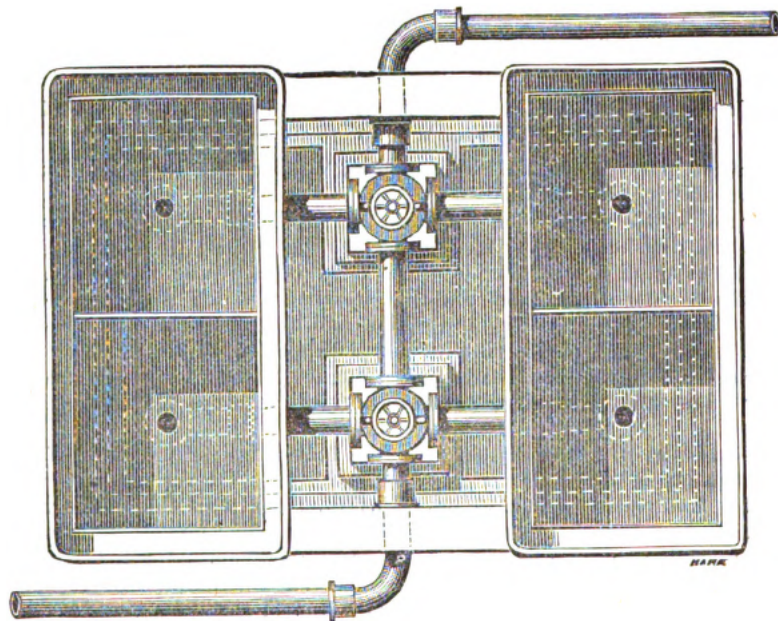
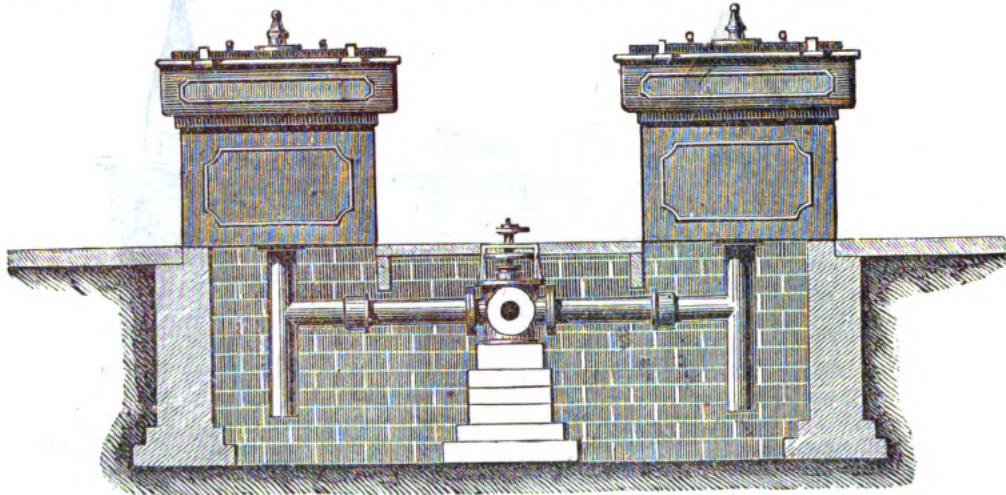

#### CAPACITY OF PURIFIERS.

A common rule for determining the size of a Purifier is to allow a purifying area of nine square feet for every 1000 cubic feet of gas produced per diem; but this should be the minimum allowance. A more preferable rule is to allow twelve square feet of grid area for every 1,000 cubic feet production in the 24 hours.

Another rule is:—When there is intended to be four Purifiers, three always in action, the maximum daily make of gas expressed in thousands multiplied by the constant .8 will give the superficial area for each Purifier—Thus; if it is required to ascertain the superficial area of each of four Purifiers for works producing 250,000 cubic feet of gas per 24 hours, then:— $250 \times .8 = 200$  feet, the superficial area of each vessel, and  $\sqrt{200} = 14.14$  feet side of square Purifier.

The other types of Purifiers are illustrated and described hereafter.

*GEORGE BOWER, ST. NEOTS, HUNTINGDONSHIRE.*

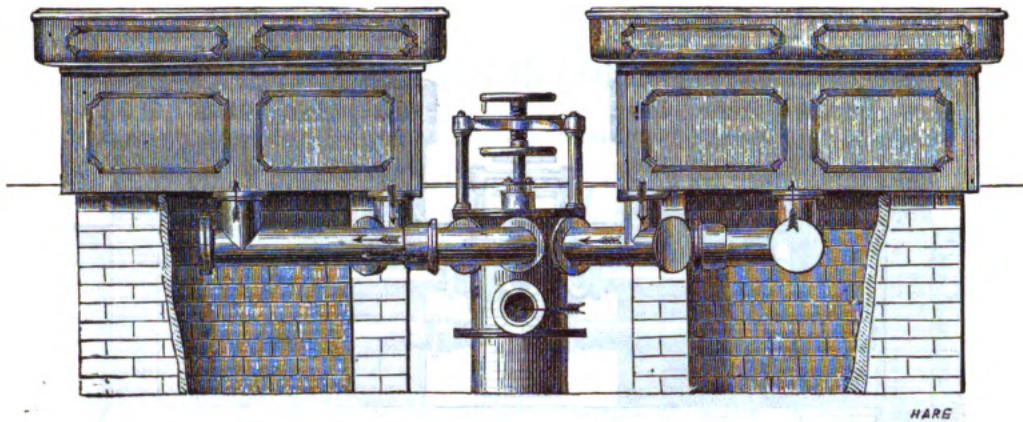

ELEVATION.

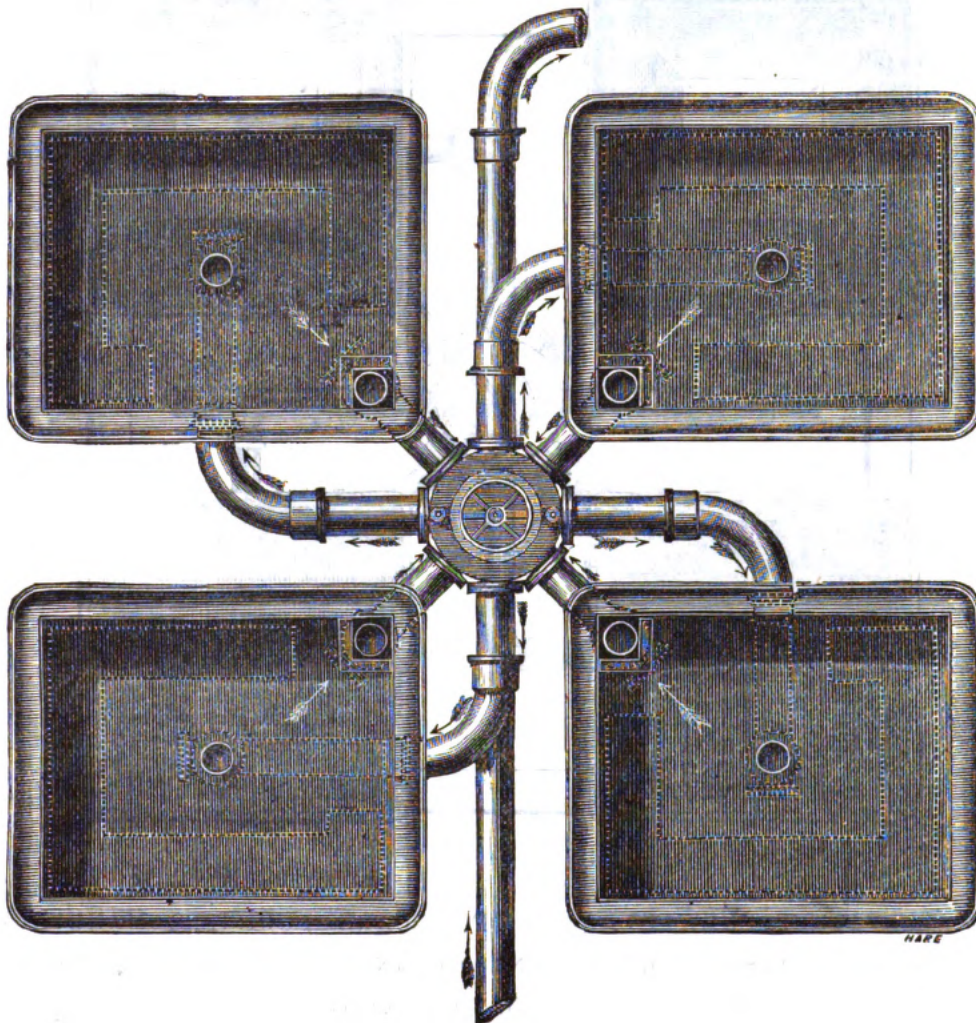

PLAN.

G. BOWER'S ARRANGEMENT OF 4 DRY LIME PURIFIERS, 5' 0" x 4' 0" x 2' 6" DEEP, WITH IMPROVED DRY CENTRE CHANGE VALVE.

GEORGE BOWER, ST. NEOTS, HUNTINGDONSHIRE.

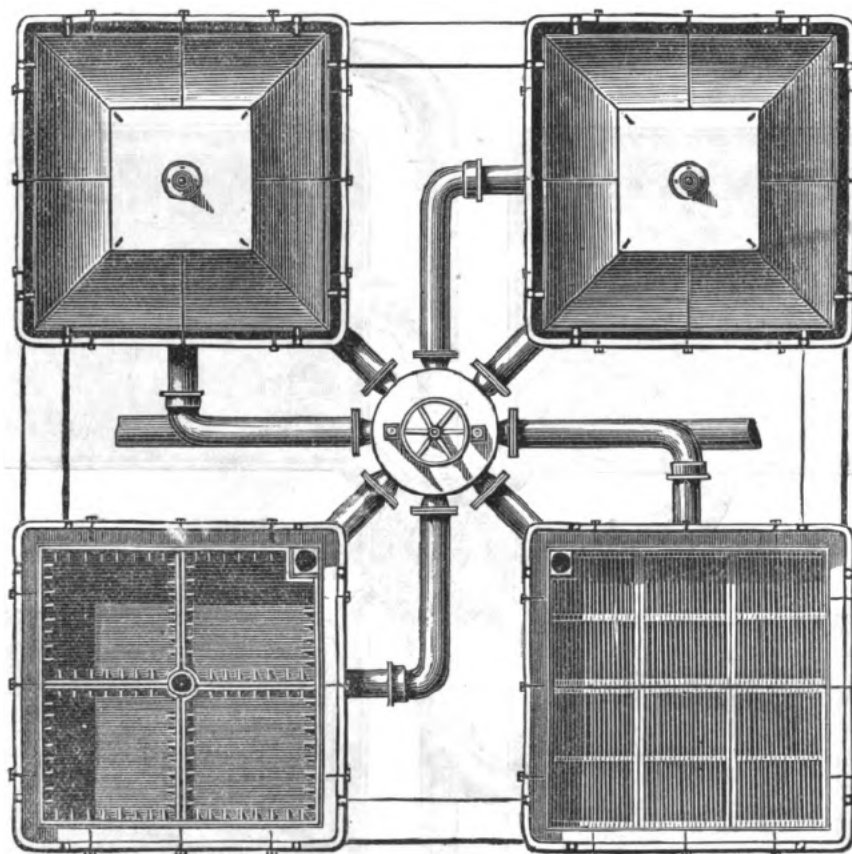
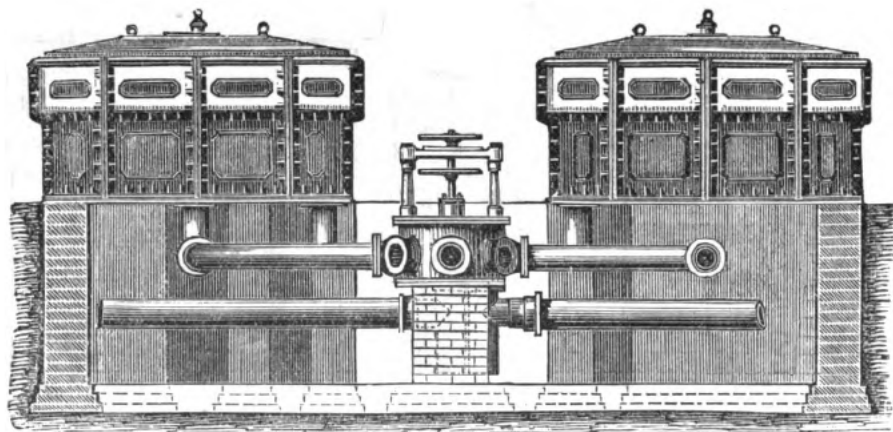

PLAN AND ELEVATION SHEWING TYPE OF SQUARE PURIFIERS MANUFACTURED BY GEORGE BOWER; ALSO, ARRANGEMENT OF INLET AND OUTLET PIPES, AND DRY CENTRE CHANGE VALVE, FOR WORKING ONE, TWO, THREE, OR FOUR PURIFIERS, AS DESIRED.

*For Sizes and Description of Purifiers see next page.*

GEORGE BOWER, ST. NEOTS, HUNTINGDONSHIRE.

## DIMENSIONS AND DESCRIPTION OF CAST-IRON PURIFIERS

MANUFACTURED AND SUPPLIED BY

# GEORGE BOWER,

*Gas and Water Engineer and Contractor, St. Neot's, Hunts.*

Each Purifier, as sent away from the Works, is fitted complete with dip, outlet box, bearer bars of wrought T iron for carrying the sieves, complete set of sieves of cast iron or wood, as may be desired, wrought iron covers with strong framework, turnbuckles for holding down the cover, and eyebolts for lifting the cover, viz., air plug, test cock, red and white lead and iron borings for making the joints, bolts, nuts, washers, and rivets complete. Painted with one coat of red oxide paint, packed, and marked for fixing.

### PURIFIERS, WITH DIPS FITTED ON, AND HAVING DIVISION PLATE IN MIDDLE.

SIZE.		DEPTH.	WATER LUTE.		NO. OF TIERS OF SIEVES.	PRICE.
feet in.	feet in.	feet in.	in.	in.		
5 0	by 2 3	2 6	8½	by 2½	4	
6 0	by 2 6	2 6	8½	by 2½	4	
8 0	by 3 6	2 6	8½	by 2½	4	

### PURIFIERS, WITH DIPS FITTED ON, BUT WITHOUT DIVISION PLATE.

SIZE.		DEPTH.	WATER LUTE.		NO. OF TIERS OF SIEVES.	PRICE.
feet in.	feet in.	feet in.	in.	in.		
2 6	by 2 6	2 8	8½	by 2½	5	
3 4	by 2 6	2 0	8½	by 2½	3	
5 0	by 4 0	2 6	8½	by 2½	4	
6 0	by 6 0	3 0	14	by 3	4	
8 0	by 8 0	3 7	12½	by 3½	5	

### PURIFIERS WITH DIPS CAST ON.

SIZE.		DEPTH.	WATER LUTE.		NO. OF TIERS OF SIEVES.	PRICE.
feet in.	feet in.	feet in.	in.	in.		
5 0	by 4 0	2 6	8½	by 2½	4	
6 0	by 6 0	3 0	12½	by 3½	4	
6 0	by 6 0	3 6	16	by 4	4, 5, or 6	
6 0	by 6 0	3 10½	21	by 4½	3 or 4	
8 0	by 8 0	3 6	16	by 4½	4	
8 0	by 8 0	3 9	15	by 4½	4	
12 0	by 12 0	3 9	15	by 5	4	
16 0	by 16 0	4 10	18	by 6	4	

All the vertical joints of the square Purifiers can be, and mostly are planed, the joints being made simply by spreading a thin layer of red and white lead putty over one of the flange faces forming the joint, and bolting same to its corresponding flange.

SOME OF THE LARGER PURIFIERS ARE MADE SUITABLE FOR CEMENT CONCRETE BOTTOMS.

PRICES OF LARGER OR OTHER SIZES ON APPLICATION.

For DESCRIPTION OF CENTRE CHANGE VALVES, See SECTION J.

GEORGE BOWER, ST. NEOTS, HUNTINGDONSHIRE.

## APPARATUS FOR RAISING AND LOWERING PURIFIER LIDS.

Numerous contrivances are adopted for raising the lids of Purifiers, but the most suitable must depend upon the size and arrangement of the purifiers themselves.

For small Purifiers, as shewn on pages 52 and 53, a simple and convenient plan is to fix two girders of wood or iron over each pair of purifiers, upon which a carriage or traveller with four flanged wheels is made to run. This traveller is fitted with a cross head and long square threaded screw, with swivel hook at lower end, for receiving one end of the chain slings. The screw is provided with a hand wheel, by the turning of which in the desired direction the lid is raised or lowered.

If wooden girders are used, flat bar iron rails must be screwed on the top, for the carriage to run upon.

A similar apparatus is applicable for lifting lids up to 12-ft. square; but instead of by the hand screw, the raising and lowering is more easily effected by a pair of Weston's blocks hung on to the suspended hook of the carriage. The other means adopted for the same object are swing cranes, travellers with suitable hoisting and propelling gear, or hydraulic power. The annexed figure represents an application of hydraulic power, by which the lids of a large purifier may be easily raised by one man and run out of the way.

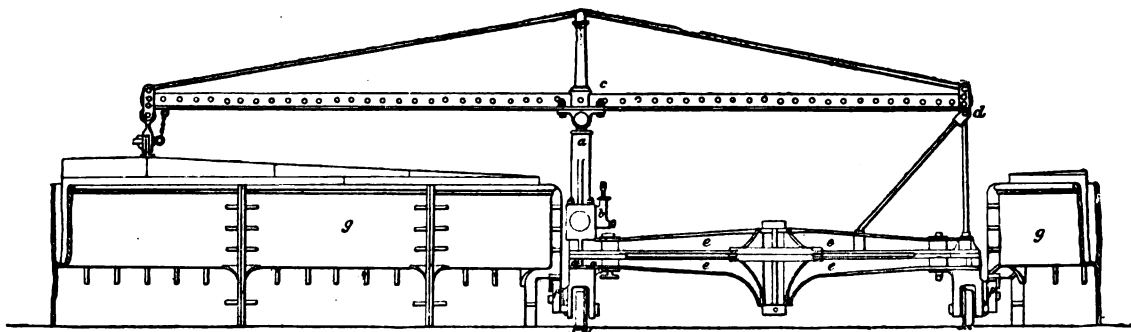

HYDRAULIC LIFTING APPARATUS AND TRAVELLER FOR PURIFIER LIDS.

## REFERENCE TO ILLUSTRATIONS.

a	Hydraulic Ram	e	Traveller with turn-table
b	Force Pump	f	Steadiment Rollers
c	Wrought iron Jib	g g	Purifiers.
d	Fixed centre on which Jib works		

## LIME FOR PURIFICATION.

The best lime that can be procured in England for removing the impurities from gas, is that made from chalk, it being the purest native carbonate. The oolitic, the magnesian, and lias limestones are inferior exactly in proportion to the amount of earthy or foreign matter they contain. A comparison of lime is very easily made by dissolving them in diluted acid; that which leaves the least insoluble base or sediment is the best.

In preparing the lime for the dry purifiers, it should be beaten, sifted fine, and water added, until by compression in the hand it will retain the form thus given to it. If any lumps remain, their outsides only are acted upon, and there is, consequently, a waste of material.

For the purpose of exposing a greater surface of lime to be in contact with the gas, it is customary in the gas works in France to place beds of moss on the trays, over which the lime is then spread.

A cubic foot of quick lime weighs about 63 lbs., or about 70 lbs. the bushel; when moistened to the proper degree, and rendered suitable for placing in the purifiers, the weight of a bushel is increased to about 90 lbs.

## CENTRE CHANGE VALVES.

One central valve is preferable to four or more slide valves, because, if the man whose duty is to attend to them were to shut those leading to the spent purifiers before he opened the others, the consequences might be serious. The sudden check thus given to the passage of the gas from the retorts would drive the tar from the hydraulic main up the dip pipes into the open retorts, if there were any not in use, and most probably do much injury. Several accidents have arisen from this cause. With the one central valve this accident cannot occur, for it is impossible to close one partition without opening another.—CLERGON Coal Gas.

[G]

## THE STATION-METER,

MANUFACTURED AND SUPPLIED BY

GEORGE BOWER,

*Gas and Water Engineer and Contractor, St. Neots, Hunts.*

In Richards' "Treatise on the Manufacture of Gas," the apparatus in question is referred to as follows :

"The importance of the station-meter in a gas-works, but more particularly in small establishments where the utmost care and intelligence are necessary in order to earn a dividend, is hardly susceptible of exaggeration, for by this instrument all the gas produced is measured and recorded hourly and daily ; it serves as a check on the quantity and quality of coals carbonized ; it shows whether the operations in the retort-house are being successfully conducted or otherwise ; and so far as regards the production and sale of gas, it affords unerring means of ascertaining the operations of the company. In addition to these advantages, the station-meter, when properly constructed, is amongst the most durable of all the apparatus in a gas manufactory. Once placed, beyond being properly supplied with water, it requires no attention, and during a series of years is a faithful recorder of all the gas produced.

"On the other hand, when this instrument is dispensed with, it is practically impossible to ascertain, with any degree of accuracy, the quantity of gas manufactured and sold. To determine this in its absence, constant reference has to be made to the gas-holders, the contents of which are continuously influenced by every change of temperature of the atmosphere ; perhaps at one hour, in consequence of the gas being expanded by the heat of the sun, showing an extraordinary fabulous make, and at another period, with reduced temperature, no production whatever. Moreover, when a holder receives and delivers the gas simultaneously, it is utterly impossible to ascertain the quantity produced. It is obvious, therefore, on these accounts that, for economical working, the instrument in question is indispensable."

The force of the preceding observations on the utility of the station-meter can only be thoroughly appreciated by the engineer or manager who has been labouring in obscurity without it ; for although an estimate of the quantity of gas produced may be formed, and the loss by leakage and the consumption of the public lamps calculated, yet only when the gross consumption of the consumers is ascertained at the end of the quarter, can an approximation to the operations of the works be ascertained. But with the station-meter each day's operations is checked, for the weight of the coal carbonized being known, in the event of the quantity of gas produced not corresponding therewith, the question arises, where is the fault?—which may consist in the quality of the coals, or the state of the retorts, either by low heats, leakage, or excessive pressure, or a combination of these. It has been asserted with some degree of exaggeration, that a house of business can as well dispense with its ledger, as for a gas-works to be without a station-meter ; but although it is not pretended to go that length, sufficient has been adduced to show its absolute necessity in any gas establishment.

The wet meter is invariably adapted as a station meter, and the kind most suitable for small and medium size works is made with a cylindrical cast iron case, fitted with pressure and water gauges, as represented in the annexed engraving. The Meter may be mounted on a pedestal of iron, stone, or brick.

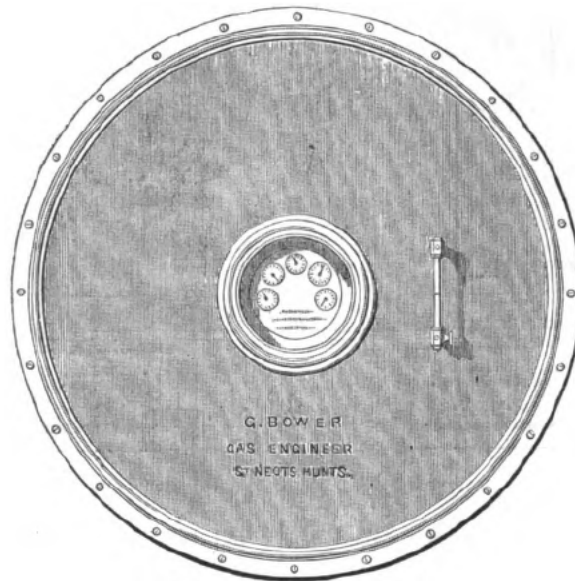

STATION METER.

GEORGE BOWER, ST. NEOTS, HUNTINGDONSHIRE.

When deciding on the capacity of a station meter, the maximum daily make in the depth of winter is the first consideration, and from that the delivery per hour is estimated. Thus, if we suppose the daily maximum production of a works to be 24,000 feet, then this quantity divided by the number of hours, gives 1,000 feet per hour as the capacity of the meter required; but it is always wise to have that of ample magnitude, in order to allow for the company's future extended business.

PRICES OF METERS WITH CYLINDRICAL CASES.

To pass	350	500	750	1000	1500	2000	2500	3000	4000	5000	£	s.	d.
To pass	350	500	750	1000	1500	2000	2500	3000	4000	5000			
"	500	"	"	"	"	"	"	"	"	"			
"	750	"	"	"	"	"	"	"	"	"			
"	1000	"	"	"	"	"	"	"	"	"			
"	1500	"	"	"	"	"	"	"	"	"			
"	2000	"	"	"	"	"	"	"	"	"			
"	2500	"	"	"	"	"	"	"	"	"			
"	3000	"	"	"	"	"	"	"	"	"			
"	4000	"	"	"	"	"	"	"	"	"			
"	5000	"	"	"	"	"	"	"	"	"			

With Tell-tale Index £ extra.

For Meters required of larger sizes than the above, prices will be given on application.

For gas works of large dimensions, the form of the case of the station-meter is changed for the purpose of rendering it more ornamental, without, however, in any way altering the internal construction or action. The accompanying figure represents a meter of this description, fitted with pressure gauges in the inlet and outlet, water gauge, overflow, water feed, and by-pass valves.

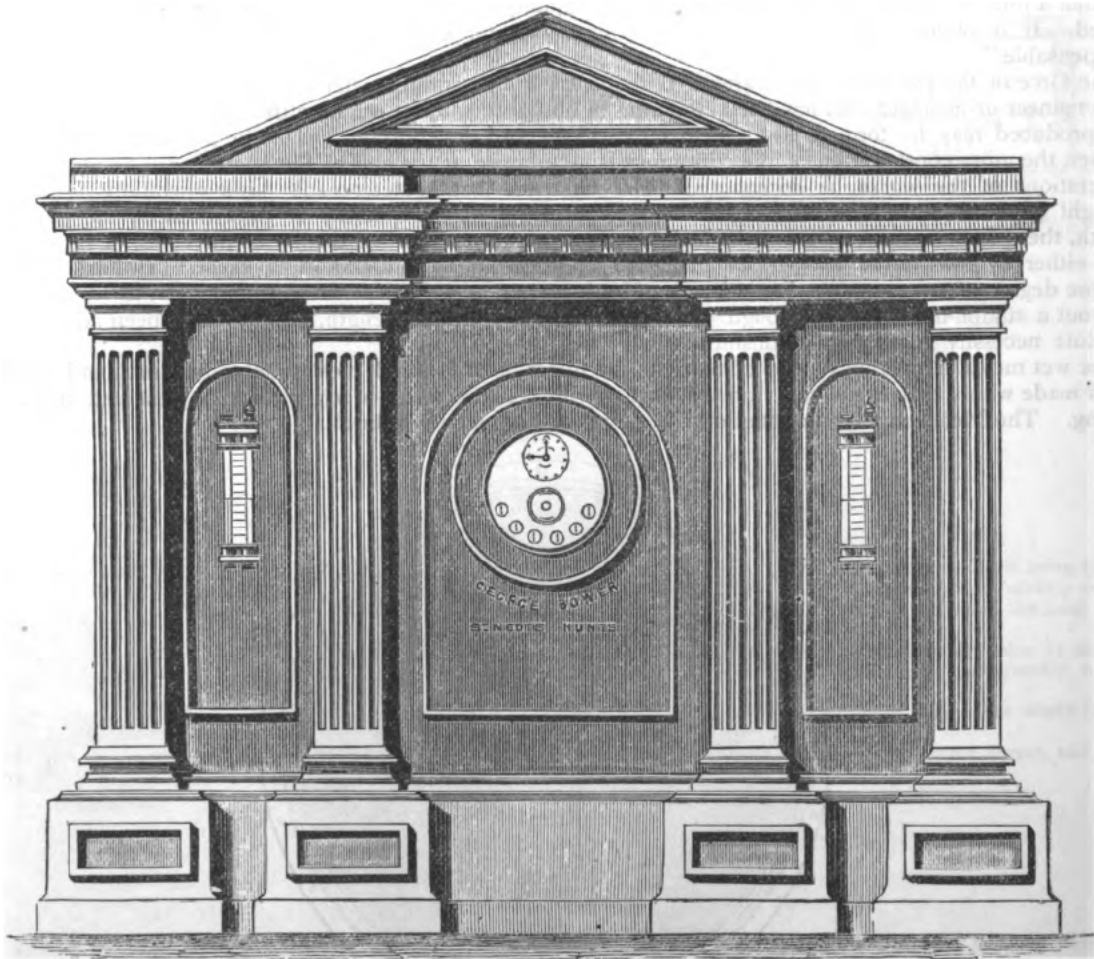

With large station meters, the appliance called the "tell tale" is invariably furnished. This consists of an index of large size, to which is attached a clock giving motion to a pencil. In the centre of the index is a revolving disc, gearing with the wheel work in such a manner that the disc shall make a revolution for a definite large quantity, and this quantity is usually equal to the maximum daily make for which the meter is constructed.

GEORGE BOWER, ST. NEOTS, HUNTINGDONSHIRE.



On this disc is placed a circular card with a scale on its outer part, corresponding with the daily make; thus, if the meter be for 240,000 feet per diem, or 10,000 feet per hour, the card is divided so as to indicate 240,000 feet in its revolution. Attached to the hour hand of the clock, and at a short distance from its centre, is a pin which gives motion to a rod, carrying the pencil in contact with the card. Thus by the slow rotary motion of the card, and the to and fro action of the pencil, a curve is marked on the card, the extreme ends of each of the curves indicates the quantity of gas produced each hour. By these simple means the strictest surveillance is kept on the carbonizing operation, so far as regards the production of gas, the circular card being changed daily for that purpose.

Although not usually adopted, the "tell-tale" is admirably adapted for small works, as by its means the operations of the night, when perhaps other surveillance does not exist, are faithfully recorded. This apparatus is capable of being applied to all kinds of station-meters when desired, its cost being £10 10s. each, in addition to the preceding list of circular-cased meters.

The dimensions of square-cased meters are so numerous as to preclude a list of prices being given, but these will always be supplied on receiving the details of the required quantity to be delivered per hour, and other necessary particulars.

An ordinary precaution to be observed with station-meters is to change the water periodically, say once in three months, which can be accomplished without stopping the instrument, by supplying the clear water in the same proportion as it is allowed to flow away by the bottom plugs.

RECENT ANALYSES OF COALS AND CANNELS, TAKEN FROM KING'S "TREATISE ON GAS-LIGHTING."

NAME OF COAL.	GAS.				COKE.		AUTHORITY.
	Gas per ton of Coals, cubic ft.	Illum. Power, Candles.	Absorption by Bromine p.cent.	Carbonic Oxide per cent.	Per ton of coals, lbs.	Ash in Coke, p. c.	
<b>CANNELS.</b>							
Boghead	13,000	40'00	25'0	1'5	670	60'0	Mr. F. J. Evans
Lesmahago	12,000	32'00	14'0	3'0	980	7'0	"
Lothian Cannel	12,700	34'00	17'0	7'0	963	6'0	"
Cleugh Cannel	12,000	30'00	7'75	10'5	1,182	12'8	"
Lochgelly	10,500	17'00	40'00	6'0	1,232	15'0	"
Ince Hall (Wigan)	10,200	20'00	12'00	3'5	1,120	8'0	"
Wigan	10,000	20'00	13'00	4'2	1,120	6'5	"
Kirkless Hall	10,500	23'00	14'00	4'0	1,232	9'5	"
Leeswood Curley	10,000	28'00	24'00	3'0	728	10'0	"
" (Average)	9,800	20'00	12'50	8'0	1,120	8'0	"
Wemyss	11,000	26'00	17'00	1'0	1,344	50'0	"
<b>VARIOUS COALS.</b>							
Pelton (Old)	11,500	13'5	5'0	5'0	1,560	2'75	"
" (New)	10,500	12'0	4'75	4'5	1,568	2'50	"
Pelaw	10,000	13'25	4'5	4'5	1,568	2'50	"
Waldridge	9,000	13'00	4'3	3'5	1,568	3'00	"
Wearmouth	10,500	13'50	4'7	3'8	1,500	2'50	"
Bute's Tanfield	10,100	13'50	4'0	3'7	1,450	3'80	"
Dean's Primrose	10,500	13'50	5'0	4'7	1,400	3'50	"
South Helton	9,600	12'70	3'0	3'2	1,470	3'70	"
Shincliffe	9,500	12'0	5'0	2'0	1,500	3'80	"
Lambton	10,500	14'0	4'3	3'3	1,560	2'80	"
Haswell	10,300	13'0	3'4	3'1	1,300	2'50	"
Silkstone } Three samples	10,400	15'64	6'25	6'25	1,366	3'00	"
	10,866	15'84	6'5	6'25	1,377	2'00	"
	10,800	15'65	4'75	7'00	1,480	6'10	"
Thorncliffe	10,500	16'50	5'5	6'50	1,433	4'80	"
Rhos Lantwit Caerphilly	9,730	15'07	7'30	8'20	..	..	Mr. Fiddes, Bristol
Powell's Lantwit, large	9,675	13'69	4'55	7'30	..	..	"
" small	11,079	15'16	6'05	10'10	..	..	"
Lydney—Norchard Coal, Coliford, High Delf Seam	10,285	14'56	5'00	8'60	..	..	"
"	9,215	15'46	4'75	10'30	..	..	"
"	8,702	14'13	4'25	9'40	..	..	"
Cannel—Varley Hill Colliery, Pontypool	9,262	17'21	6'20	3'60	..	..	"
Gas Coal from ditto	9,021	15'47	5'80	4'90	..	..	"
Tyr Filkens, Newport, Monmouth	11,835	13'60	4'30	5'90	..	..	"
Lydney, Tranchard Seam	9,870	14'77	5'45	8'60	..	..	"
Pellowell, near Lidney	9,785	13'84	4'25	10'15	..	..	"
Llantwit Red Ash, Pontypridd, small coal	9,390	15'06	5'80	8'90	..	..	"
" large	9,708	16'33	6'46	8'33	..	..	"
Dean's Primrose	9,800	16'00	..	..	..	..	Mr. G. Livesey
Holmside	9,800	16'00	..	..	..	..	"
West Leversons	9,464	15'50	..	..	..	..	"
Townley	9,200	15'30	..	..	..	..	"
Washington	9,200	16'00	..	..	..	..	"
Nettlesworth Primrose	9,500	..	..	..	..	..	"
West Pelaw	9,537	..	..	..	..	..	"
Norfolk Silkstone	10,000	17'50	..	..	..	..	"
Teesdale	9,468	..	..	..	..	..	"

## CAPITAL OF THE METROPOLITAN GAS COMPANIES IN THE YEAR 1875.

COMPANY.	INCORPORATED	STOCK AND SHARES.			LOAN.	TOTAL.
		Max. Dividend	Minimum dividend.			
		10 per cent.	Per cent.			
The Gas Light . . . . .	June, 1810	£4,050,000	4	£100,000	£1,063,500	£5,213,500
Imperial . . . . .	" 1821	1,560,000	7	1,300,000	498,000	3,358,000
Independent . . . . .	" 1829	165,000	{ 5 7½	{ 30,000 60,000 }	..	255,000
These three Companies have since then been amalgamated		£5,775,000	..	£1,490,000	£1,561,500	£8,826,500
Commercial . . . . .	June, 1847	450,000	..	..	..	450,000
Ratcliff . . . . .	" 1823	100,000	..	..	20,000	120,000
London . . . . .	July, 1844	397,150	{ 5 and 6 6	{ 26,692 450,000 }	191,667	1,065,509
Phoenix . . . . .	May, 1824	540,000	{ 5 7½	{ 144,000 360,000 }	200,000	1,244,000
South Metropolitan . . . . .	June, 1842	500,000	..	..	..	500,000
Surrey Consumers' . . . . .	July, 1854	250,000	..	..	60,000	310,000
The Commercial and Ratcliff have also since amalgamated with additional capital of .		£8,012,150	..	£2,470,692	£2,033,167	£12,516,009 560,000
Total Capital of the Metropolitan Companies						£13,076,009

FIELD'S Analysis of the Metropolitan Gas Accounts.

## RECEIPTS FOR GAS, COKE, AMMONIA, TAR, &amp;c., OF THE METROPOLITAN GAS COMPANIES IN THE YEAR 1875.

Company.	Gas Receipts.	Profit on Gas.	Receipts for Coke.	Per ton of Coal carbonized.	Receipts for Ammonia.	Receipts for Tar.
The Gas Light . . . . .	£896,705	£320,178	£137,877	s. d. 5 7'61	£45,332	£61,596
Imperial . . . . .	719,851	274,321	132,635	6 0'50	31,503	46,858
Independent . . . . .	96,514	33,788	25,752	8 2'91	3,867	8,850
Total of the three Companies	£1,713,070	£628,287	£296,264	average 5 11'75	£80,702	£117,313
Commercial . . . . .	164,167	53,769	34,810	7 2'00	6,299	8,247
Ratcliff . . . . .	36,870	16,662	8,535	7 11'89	1,892	2,927
London . . . . .	215,109	78,772	44,786	7 8'96	8,915	10,487
Phoenix . . . . .	265,806	102,112	55,526	7 7'78	6,481	6,264
South Metropolitan . . . . .	125,716	42,706	35,444	7 10'16	6,055	11,492
Surrey Consumers' . . . . .	86,100	29,300	17,562	7 11'10	1,607	5,421
	£2,606,818	£951,608	£492,927	average 6 6'61	£111,951	£162,151

FIELD'S Analysis.

[H]

## G A S - H O L D E R S ,

MANUFACTURED AND SUPPLIED BY

GEORGE BOWER,

*Gas and Water Engineer and Contractor, St. Neots, Hunts.*

Towards the end of the last century the study of gas was called Pneumatic Chemistry; and for this, beyond the apparatus, such as the pneumatic trough and jars, with the bladder first used by Shirley, but afterwards rendered self-acting by being combined with a disc and spring, no other apparatus for storing gas existed. This want being experienced by the great French chemist, Lavoisier, he directed his attention to a means of overcoming the difficulty, and about the year 1782 he succeeded in inventing the gas-holder; but in this, his principal aim was to obtain a continuous stream of gas, as well as a larger store than had hitherto been obtained, and also a knowledge of the quantity of gas contained in the vessel, and from this circumstance he termed it a "Gazometer," or gas-meter. The first holder made by Lavoisier was of about two cubic feet, suspended and counterbalanced by a beam and weights supported on a pillar, similar to an ordinary regulator as sometimes now made.

The gas-holder consists of two parts, viz., the *holder*, properly speaking, for the gas, or the *bell*; and the *tank*, which contains the water necessary for the action of the apparatus. The water in the tank serves three distinct purposes, as it is the medium of resistance to the pressure of the gas, so causing the holder to rise; it displaces the gas when the holder descends; and, lastly, it forms a seal, and prevents the gas escaping.

On the first introduction of gas-lighting the holders and tanks were square, but the cylindrical form was generally applied about 1816. At that time wooden vats, similar to those used by brewers, were commonly employed as tanks for the gas-holders, but the accidents arising from their bursting rendered more substantial reservoirs desirable; thus brick tanks, and, subsequently, cast-iron, and, in a few instances, wrought-iron tanks became generally employed.

Gas-holders are either single lift, as represented in pages 63 and 64, or double lift, as shown in pages 65 and 66; and in some cases they are made with three lifts.

The engraving on page 63 represents a single lift holder, such as is suitable for a very small town or village, manufactory, school, or other large establishment. This is guided by four columns, and in order to reduce the pressure to the most favourable degree for carbonizing, it is counterbalanced by weights suspended at the four columns, which system is to be recommended wherever rigid economy is desired.

The other description of single holder is represented on page 64, with its tank in section, and, on account of the absence of the counter-balance weights, it is termed self-sustaining. When these are of large diameter and limited depth, they are sufficiently light without counterbalancing; and when they are of extraordinary diameter, the plates forming the holder are increased in thickness in order to give the desired pressure for the supply of the town or district.

The double lift holder is formed by a holder of the ordinary construction, having an annular cup of from 10 to 18 inches deep, and from 6 to ten inches wide, attached to its lower part. Concentric to this is a second cylinder, or "lift," formed of the same material, of the same height as the ordinary holder, but, of course, of somewhat larger diameter. This "lift" has around its upper part an annular "grip," corresponding in depth and width with the annular cup. Thus, as the first holder is filled with gas, it rises and lifts with it the annular cup filled with water; and as the grip of the lift dips into the cup, a hydraulic seal is formed which prevents the gas escaping at that point, and the lift is carried up by the holder until the two combined attain a height equal to about double the depth of the tank. By these means the capacity of a gas-holder for a tank of given dimensions is doubled, and this economy of construction is the principal cause for their adoption.

*Gas-holder Tanks.*

These are constructed of brick-work, masonry, concrete, or a combination of these, and termed composite tanks. They are also made of cast, and sometimes of wrought-iron; and, in a few instances, of cast-iron in combination with concrete and clay or brick-work.

GEORGE BOWER, ST. NEOTS, HUNTINGDONSHIRE.

The kind of tank requisite for any locality will depend on a number of circumstances, such as the nature of the site, whether water exists therein to such a degree as to impede the operations, or the description of material available for the purpose; as also its cost. These, and various other circumstances, will always influence the engineer in the selection of the description of tank to be adopted. In England, however, where plastic clay is generally found in abundance, and bricks are cheap, brick tanks are usually built; hydraulic lime, such as blue lias, may be employed for the mortar, or, what is still better, Portland cement intermixed with two parts of clean sand. All the bricks should be thoroughly saturated with water at the time of laying, and each brick embedded in the cement or mortar so as to fill all the joints; if these precautions are observed, the tank may be made sound in clayey soil without the assistance of puddle, hereafter mentioned. The centre of the tank is usually left in the form of a frustrum of a cone, or a dome, over which is placed a layer of concrete, either made with hydraulic lime or Portland cement; which may be so prepared as to be impermeable in itself, but generally one or more courses of flat tiles, or a coating of cement, are laid over the concrete.

Formerly, it was the custom of engineers to build these tanks on a layer of puddle, and surround the whole of the sides with the same material; and when the material or workmanship of a tank cannot be relied on, this precaution of puddling the whole area of the tank is no doubt advisable. But, on the other hand, there are localities where clay for the purpose cannot be obtained, and it then becomes absolutely necessary to dispense with it; when under these conditions, tanks are successfully constructed either of brick or stone without puddle.

In certain localities the building material is exclusively of stone, which material is admirably adapted for building tanks. For this purpose, the stones for the facing of the sides are squared, and on being laid are backed with rubble to the desired thickness of the wall. A few instances are recorded, where the site of the tank being composed of good plastic clay, the interior has been left as excavated, and thus only the wall was required to be built either of brick or stone. These are, necessarily, the cheapest kinds of tanks.

Within the last few years concrete, either with a facing of brickwork, or concrete alone, has been employed with success for gas-holder tanks. In places where gravel is abundant this system is economical, but demands extraordinary care in the manipulation. Therefore, with all these variable conditions, it is obvious that no approximation to the cost of a tank of any given capacity can be given without a knowledge of the site and all the other essential information concerning the cost of labour and building materials; however, according to the experience obtained in various localities, the cost of brick and stone tanks ranges from £10 to £30 per 1000 feet of holder.

There are, however, places where the ground does not permit of a tank being excavated, either from the site being marshy, or liable to inundations, or the presence of water in abundance at a short distance from the surface; when it becomes advisable to construct the tank of cast or wrought-iron.

The principal advantages of these are, that they can be placed in almost any locality. In marshy ground, piles can be driven into the solid ground, and planked over, and on this the tank may be placed. In gravelly ground, on this being levelled, the bottom plates of the tank are at once laid, all the plates forming the bottom being placed in their positions before commencing to cement the joints. Briefly cast-iron tanks can be placed in any locality without requiring any excavation, and they have the further advantage of requiring a limited amount of skilled labour to erect them. In a clayey site sometimes only the outer wall is built of cast iron, the interior of the tank being left as excavated. In other instances, the centre is formed of concrete; and both of these systems are to be recommended on the ground of economy, wherever they can be practically applied.

With small tanks up to 30 feet diameter, the columns are attached to brackets secured to the upper tier of plates of the tank. In large tanks, piers of brickwork or masonry are built in order to carry the guide columns of the holder. These are invariably detached from the tank to avoid any ill effects by their "settlement." Should the ground be unstable, piles will have to be driven to support the piers.

~~~~~

*In connection with Gas-holders the following can be supplied:—*

CAST-IRON DRY WELL FOR SYPHON BOXES.  
 CAST-IRON GUIDE COLUMNS, OR TRIPODS.  
 CAST-IRON GIRDERS FOR CONNECTING THE  
 TOPS OF COLUMNS.  
 WROUGHT-IRON GIRDERS FOR DITTO.  
 GUIDE ROLLERS, WITH CARRIAGES, ADJUSTING  
 PLATES, ETC.  
 CAST- AND WROUGHT-IRON GUIDE TROUGHS  
 FOR SIDES OF TANKS.  
 DITTO DITTO GUIDE BARS FOR GUIDE COLUMNS.  
 CHAIN PULLEYS, WITH CARRIAGES, ETC.

TESTED SHORT LINK CHAINS.  
 CAST-IRON BALANCE WEIGHTS.  
 HOLDING DOWN PLATES AND BOLTS.  
 TANK SYPHON BOXES FITTED.  
 FLANGE OR DUCK FOOT BENDS, FOR INTERIOR  
 OF TANK.  
 SUCTION BENDS.  
 TELESCOPIC GAS-HOLDERS OF ANY SIZE.  
 GAS-HOLDERS REPLACED, REPAIRED, ENLARGED,  
 OR MADE TELESCOPIC, AS REQUIRED.

ELEVATION OF GAS-HOLDER COUNTER-BALANCED.

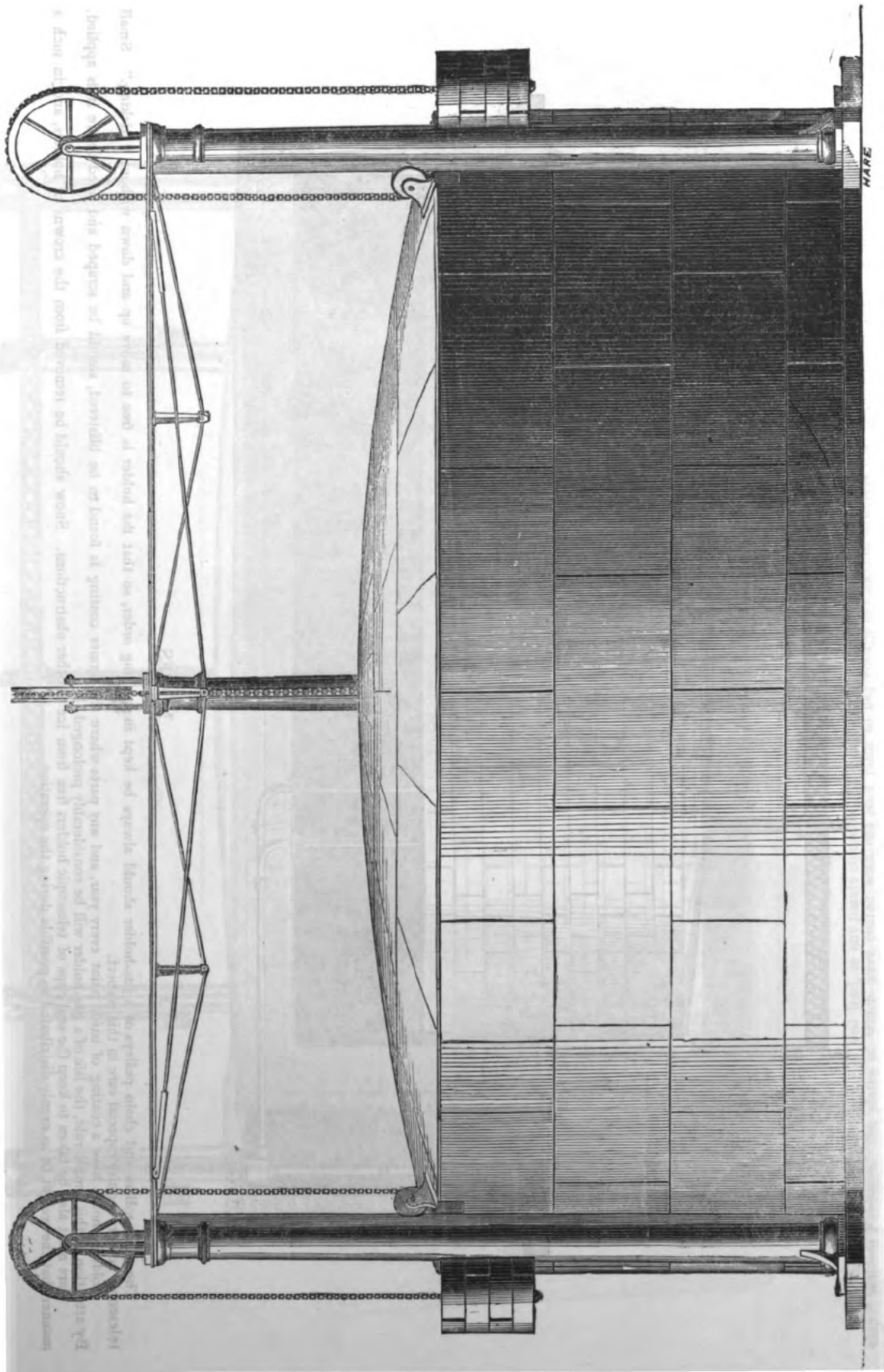

GEORGE BOWER, ST. NEOTS, HUNTINGDONSHIRE.

ELEVATION OF SELF-SUSTAINING GAS-HOLDER, WITH IRON TANK.

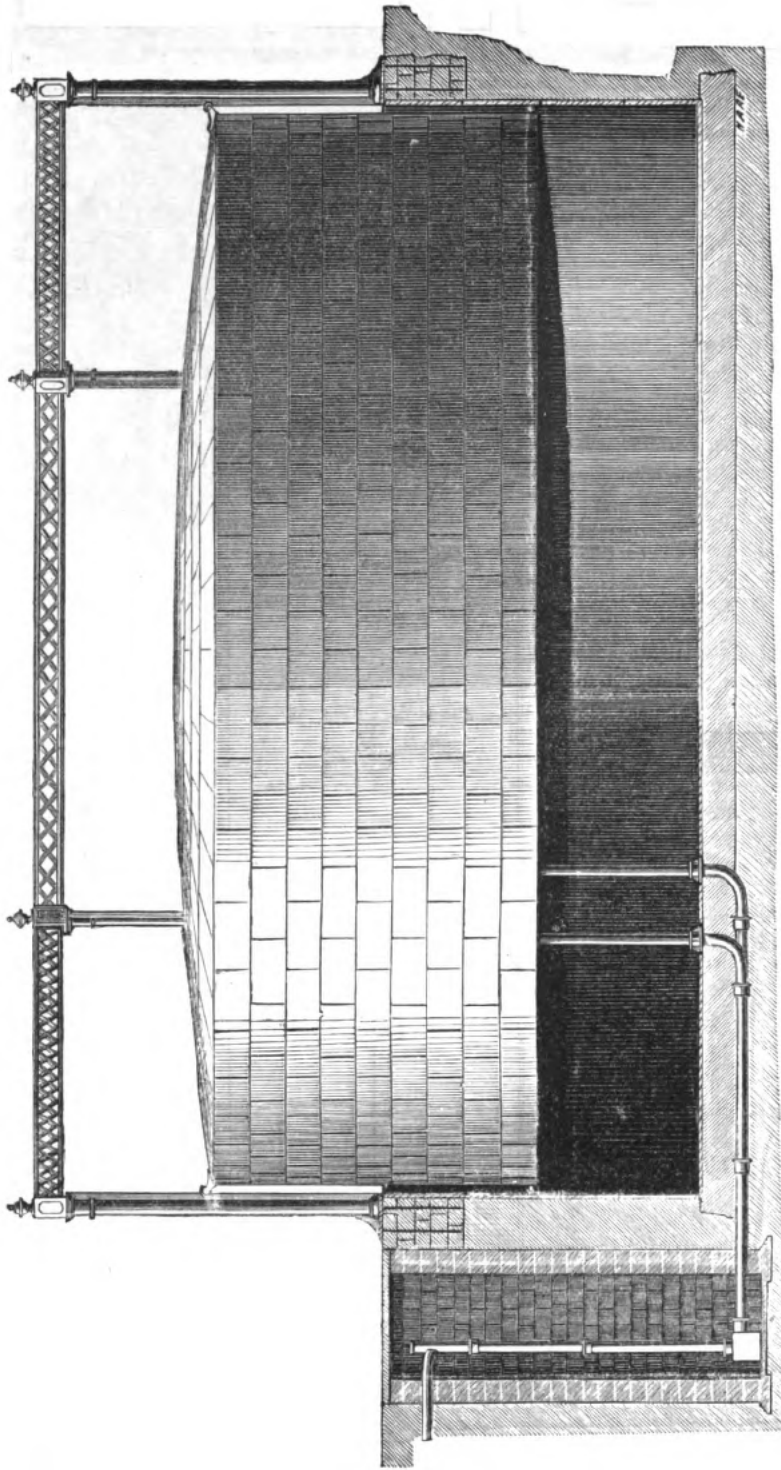

NOTES.

The guide rollers and chain pulleys of a gas-holder should always be kept in working order, so that the holder is free to move up and down without "sticking." Small telescopic holders require especial care in this respect.  
 Holders should have a coating of oxide paint every year, and any parts where the former coating is found to be blistered, should be scraped and oiled before it is applied.  
 By attention to this simple rule, the life of a gas-holder will be considerably prolonged.  
 Care must also be taken to keep the seal cups of telescopic holders free from ice or other obstructions. Snow should be removed from the crowns of holders, and in such a manner that the weight be as evenly distributed as possible during the operation.

ELEVATION OF TELESCOPIC GAS-HOLDER.

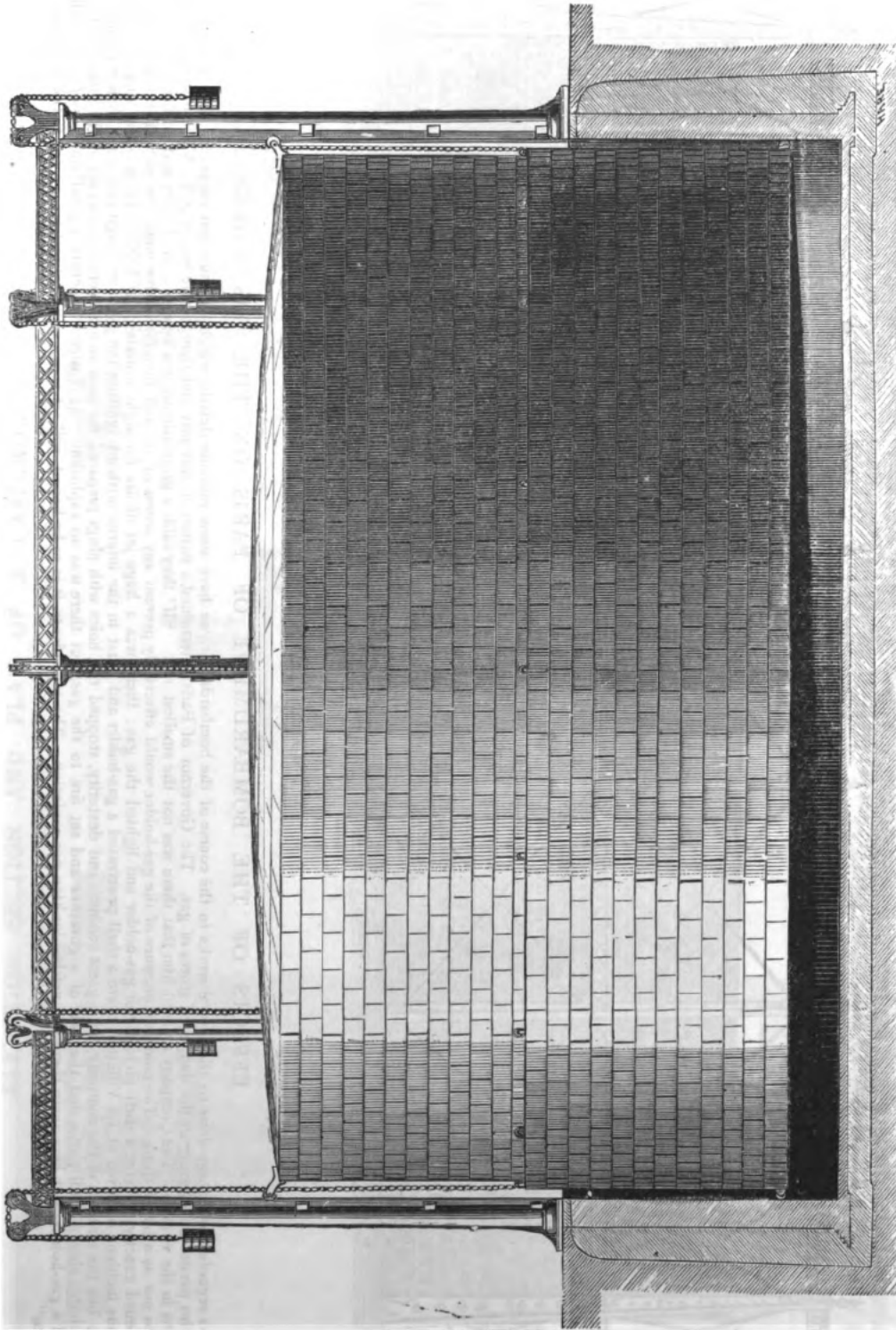

It has been found that the use of red lead, or any paints containing lead, for the purpose of coating iron vessels is very pernicious. Mr. N. Mercer, after inspecting the iron ship "William Fairbairn," the plates of which were coated with red lead prior to her voyage to Calcutta, observes that the extent to which the iron had been corroded could not fail to attract the attention of a close observer. On an inspection he found the red lead coating covered with blisters, from each of which, on being opened, a clear fluid escaped, and left exposed on the surface of the iron a number of brilliantly shining crystals of metallic lead. Mr. Mercer says each blister is, in fact, a galvanic battery in miniature, and that, as wherever there is electrical, there must also be chemical action, the corrosion is easily accounted for. This action, he says, will continue as long as any red lead remains, and is necessarily at the expense of the iron. He also points out that the "sweat" so well known to every person interested in iron ships, is not, as is generally supposed, salt water, but a solution of chloride of iron manufactured in the blisters. Mr. Mercer considers the sweating is due, in a great degree, to the use of red lead paint in immediate contact with iron.

## ELEVATION OF A TELESCOPIC GAS-HOLDER ERECTED AT BUENOS AYRES

BY

GEORGE BOWER, ST. NEOTS.

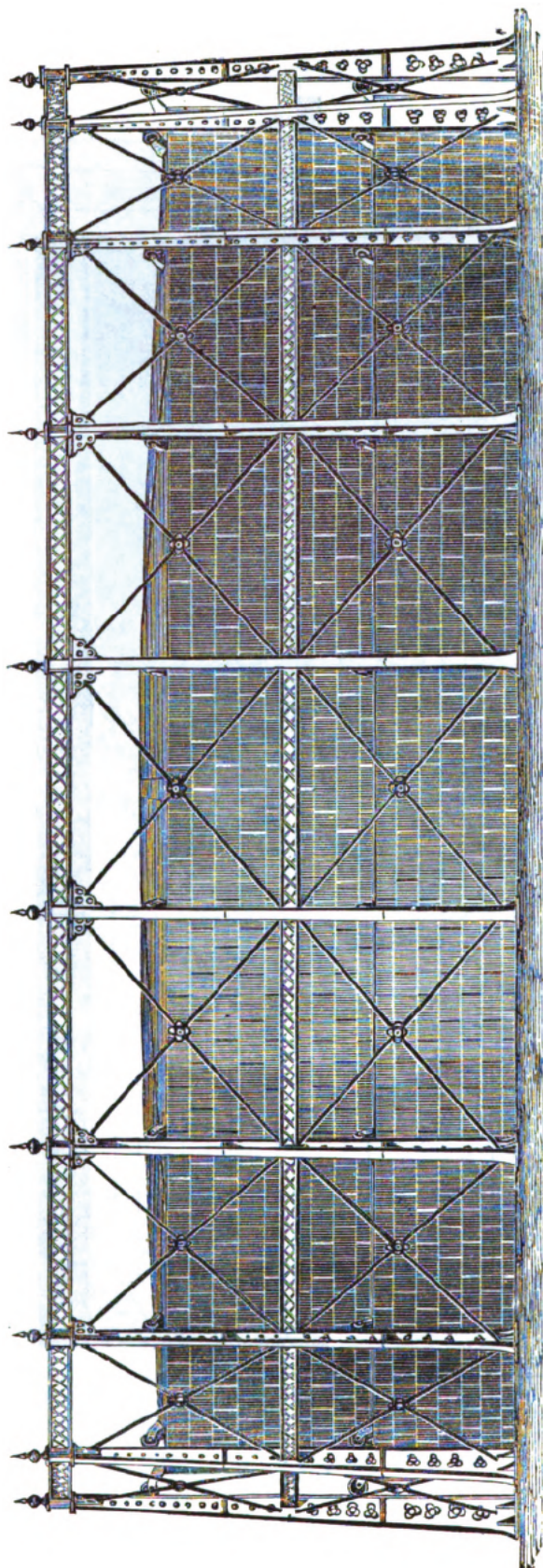

GEORGE BOWER, ST. NEOTS, HUNTINGDONSHIRE.

## EFFECTS OF THE BOMBARDMENT OF PARIS ON THE GAS WORKS.

"As regards the damage done to the several works in the course of the bombardment, we have some valuable details, which we must put on record here for the information of those who persist in believing in the danger of stores of gas. The Governor of Paris entertained a notion of this sort and thought the works at La Villette were dangerous to the fortifications in the vicinity. The Company assured him that there was not the smallest risk. 'If' they said, a projectile made a hole in a gas-holder and set fire to the gas, it would simply burn out as a jet of flame. The constant pressure of the gas-holder would effectually prevent any access of air, and therefore there could be no such thing as an explosion. This happened exactly at Ivry; a shell pierced the gas-holder and lighted the gas: there was a huge jet of fire for eight minutes, the holder slowly sank, and all was over. A more curious incident occurred at La Villette; there a shell penetrated a gas-holder and burst in the interior without igniting the gas, nine fragments made their way out in different directions; but the servants of the company, with great coolness and dexterity, stopped the holes with plugs prepared for such an emergency and so saved the greater part of the gas. At La Villette, also, a shell perforated the bell of a governor and set fire to the gas, but there was no explosion. At Vaugirard, where a great number of shells fell, only one penetrated a gas-holder, and here again there was neither ignition nor explosion. These incidents, it is to be hoped, will set men's minds at rest for ever, as to the supposed dangers of gas-holders."



ELEVATION SECTION AND PLAN OF A CAST-IRON DRY WELL.

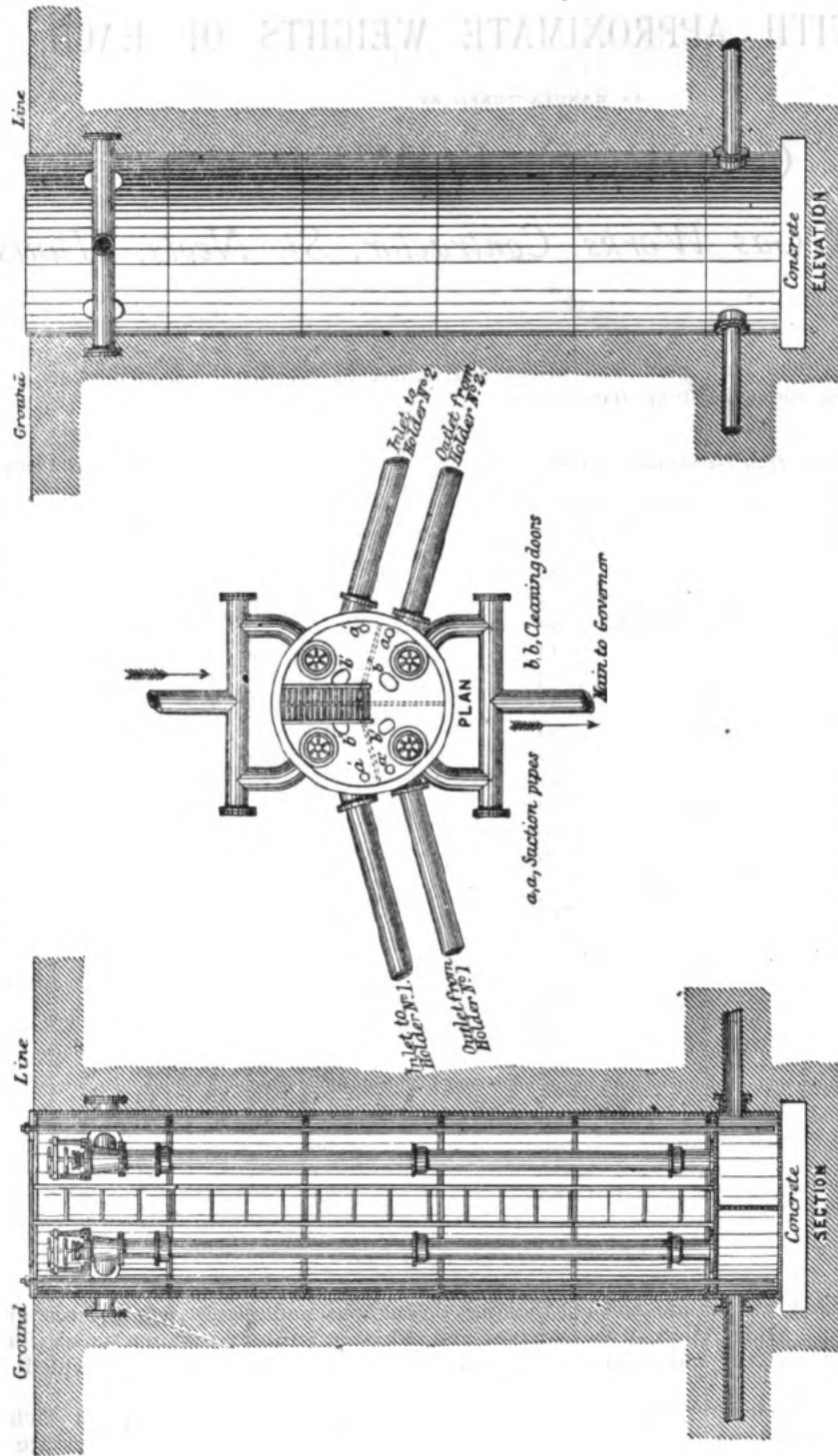

The above engraving represents a cast-iron dry well for two gas-holders. The arrangement is simple and complete, and by its adoption the possibility and trouble of an unsound well is entirely obviated. The well itself is formed of a number of cylinders with inside flanges, all of which are faced. The bottom of the well consists of a circular cistern with four divisions, as indicated in the plan, two of which serve as inlets and the other two as outlets; each one being provided with a wrought-iron suction pipe, extending through the cover of well, for the purpose of emptying some of any tar or liquor which collects there. On the top of this cistern four flange socket pieces are fixed for receiving the several stand pipes, each stand pipe being fitted at the top with a stop valve. Over each division of the cistern is a cleaning door. The plan of connecting the inlets and outlets to stand pipes and gas-holders is clearly shown in the plan.

LIST OF STANDARD SIZES OF GAS-HOLDERS AND CAST-IRON TANKS, WITH APPROXIMATE WEIGHTS OF EACH,

AS MANUFACTURED BY

GEORGE BOWER,

Engineer and Gas Works' Contractor, St. Neots, Hunts.

The Gas-holders are constructed of good Staffordshire plates, riveted together by  $\frac{1}{4}$  inch rivets of the best iron, and provided with strong and substantial frame-work.

| Size of Gas-holders. |                    | Contents in cubic feet. | Number of Guide Columns. | If Self-sustaining or Counter-balanced. | Weight of Iron-work. | Prices. | Iron Tanks for Gas-holders. |                      |                  |                    |       |                 |   |    |    |
|----------------------|--------------------|-------------------------|--------------------------|-----------------------------------------|----------------------|---------|-----------------------------|----------------------|------------------|--------------------|-------|-----------------|---|----|----|
| diam. feet.          | depth. in.         |                         |                          |                                         |                      |         | Size.                       | Weight of Iron-work. |                  | Prices.            |       |                 |   |    |    |
|                      |                    |                         |                          |                                         | cwts.                | £       | s.                          | d.                   | diam. feet.      | depth. in.         | tons. | cwts.           | £ | s. | d. |
| 5                    | by 2 $\frac{1}{2}$ | 50                      | 1                        | self-sustaining                         | 2 $\frac{1}{2}$      |         |                             |                      | 5 $\frac{1}{2}$  | by 2 $\frac{1}{2}$ | 0     | 3 $\frac{1}{4}$ |   |    |    |
| 6                    | by 4               | 120                     | 2                        | counter-balanced                        | 10                   |         |                             |                      | 6 $\frac{1}{2}$  | by 4               | 0     | 5               |   |    |    |
| 6                    | by 6               | 180                     | 2                        | "                                       | 12                   |         |                             |                      | 6 $\frac{1}{2}$  | by 6               | 0     | 7 $\frac{1}{2}$ |   |    |    |
| 8                    | by 8               | 400                     | 3                        | "                                       | 23                   |         |                             |                      | 8 $\frac{1}{2}$  | by 8               | 0     | 14              |   |    |    |
| 10                   | by 6               | 500                     | 3                        | "                                       | 23                   |         |                             |                      | 10 $\frac{1}{2}$ | by 6               | 0     | 19              |   |    |    |
| 12                   | by 8               | 900                     | 3                        | "                                       | 33                   |         |                             |                      | 12 $\frac{1}{2}$ | by 8               | 6     | 10              |   |    |    |
| 14                   | by 8               | 1,250                   | 3                        | "                                       | 40                   |         |                             |                      | 14 $\frac{3}{4}$ | by 8               | 7     | 13              |   |    |    |
| 16                   | by 10              | 2,000                   | 3                        | "                                       | 51                   |         |                             |                      | 16 $\frac{3}{4}$ | by 10              | 9     | 15              |   |    |    |
| 18                   | by 10              | 2,600                   | 3                        | "                                       | 60                   |         |                             |                      | 18 $\frac{3}{4}$ | by 10              | 11    | 17              |   |    |    |
| 20                   | by 10              | 3,500                   | 3                        | "                                       | 69                   |         |                             |                      | 21               | by 10              | 13    | 0               |   |    |    |
| 22                   | by 10              | 3,800                   | 3                        | "                                       | 76                   |         |                             |                      | 23               | by 10              | 18    | 0               |   |    |    |
| 25                   | by 10              | 5,000                   | 4                        | self-sustaining                         |                      |         |                             |                      | 26               | by 10              | 22    | 4               |   |    |    |
| 30                   | by 10              | 7,000                   | 4                        | "                                       | 116                  |         |                             |                      | 31               | by 10              | 28    | 0               |   |    |    |
| 30                   | by 10              | 8,600                   | 4                        | "                                       | 123                  |         |                             |                      | 31               | by 12              | 29    | 10              |   |    |    |
| 35                   | by 10              | 9,600                   | 5                        | "                                       | 148                  |         |                             |                      | 36               | by 10              | 34    | 15              |   |    |    |
| 40                   | by 12              | 15,000                  | 5                        | "                                       | 184                  |         |                             |                      | 41               | by 12              | 46    | 0               |   |    |    |
| 45                   | by 15              | 24,000                  | 6                        | "                                       | 270                  |         |                             |                      | 46               | by 15              | 75    | 0               |   |    |    |
| 50                   | by 15              | 30,000                  | 6                        | "                                       | 320                  |         |                             |                      | 51               | by 15              | 87    | 0               |   |    |    |
| 55                   | by 16              | 38,000                  | 7                        | "                                       | 500                  |         |                             |                      | 56 $\frac{1}{2}$ | by 16              | 108   | 0               |   |    |    |
| 60                   | by 18              | 51,000                  | 7                        | "                                       | 600                  |         |                             |                      | 61 $\frac{1}{2}$ | by 18              | 130   | 0               |   |    |    |
| 60                   | by 20              | 65,550                  | 7                        | counter-balanced                        | 800                  |         |                             |                      | 61 $\frac{1}{2}$ | by 20              | 136   | 0               |   |    |    |
| 65                   | by 20              | 66,300                  | 7                        | self-sustaining                         | 760                  |         |                             |                      | 66 $\frac{1}{2}$ | by 20              | 165   | 0               |   |    |    |
| 70                   | by 20              | 77,000                  | 8                        | "                                       | 1,000                |         |                             |                      | 71 $\frac{1}{2}$ | by 20              | 193   | 0               |   |    |    |
| 80                   | by 20              | 100,500                 | 12                       | "                                       | 1,280                |         |                             |                      | 81 $\frac{1}{2}$ | by 20              | 290   | 0               |   |    |    |

(For Engravings, see pages 63 to 66.)

Each Gas-holder is provided with guide columns, holding down bolts and plates, wrought-iron girders for connecting the tops of columns, guide rollers, with carriages and adjusting plates; cast-iron finials for tops of columns, chains, pulleys, carriages, pins and balance weights, bolts, cement, etc.; the whole painted with one coat of oxide paint.

The Gas-holder crowns are riveted together in pieces suitable for transport or shipment, and each piece is plainly marked or numbered, so that no mistake can occur in fixing. The tanks for Gas-holders are properly fitted and marked, and are supplied with bolts, rivets, cement, and wrought iron bands.

The above weights of tanks include bottom, but they can be so constructed that the bottom may be made of concrete.

Prices for larger sizes of Gas-holder or Tanks given on application.

[I]

# G O V E R N O R S ,

MANUFACTURED AND SUPPLIED BY

## GEORGE BOWER,

*Gas and Water Engineer and Contractor, St. Neots, Hunts.*

### THE STATION GOVERNOR.

This instrument serves to control, or "govern," the pressure of the gas existing in the holder or holders, to suit the requirements of the town or district supplied. Its action is automatic, and once adjusted to any particular pressure, this is rigidly maintained, irrespective of any variation in the pressure of the holders supplying, or the quantity of gas consumed in the town. The Station Governor is placed in the supply main, and sometimes in connection with the Pressure Register hereafter mentioned. The annexed figure represents a form of governor in which the whole of the upper part is enclosed, and thus the chances of accident, which have sometimes unfortunately occurred with other descriptions of apparatus, are entirely avoided. The instrument being connected with a pressure gauge, the pressure is controlled by placing weights on the lever, as shown, until the proper degree is indicated by the gauge.

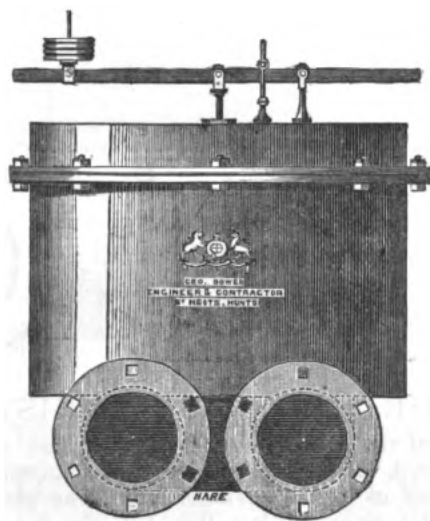

STATION GOVERNOR.

With the exception of the holder, or inverted cup, these Governors are constructed of cast iron, and fitted with conical valves of a short lift, together with the spindle, lever, and balance weights. The top is formed by a cast iron cover, which carries the lever with stand, etc., and they are so constructed as to regulate the pressure with the utmost delicacy.

#### PRICES OF STATION GOVERNORS OF THE ABOVE DESCRIPTION.

|                              | £ | s. | d. |
|------------------------------|---|----|----|
| 3 inch Connections . . . . . |   |    |    |
| 4 " " . . . . .              |   |    |    |
| 5 " " . . . . .              |   |    |    |
| 6 " " . . . . .              |   |    |    |

For Description of larger sizes, see next page.

For BY-PASS VALVES AND GOVERNORS, See SECTION J.

GEORGE BOWER, ST. NEOTS, HUNTINGDONSHIRE.

The arrangement of Governor illustrated below is suitable for larger sizes from 7 inches to 36 inches.

The flow of gas is regulated by a cone valve, which opens or closes the inlet to Governor, according to the pressure desired in the mains; such pressure being controlled by placing weights upon the suspension rod provided for the purpose, and attached to the bell of the Governor by a chain passing over two pulleys.

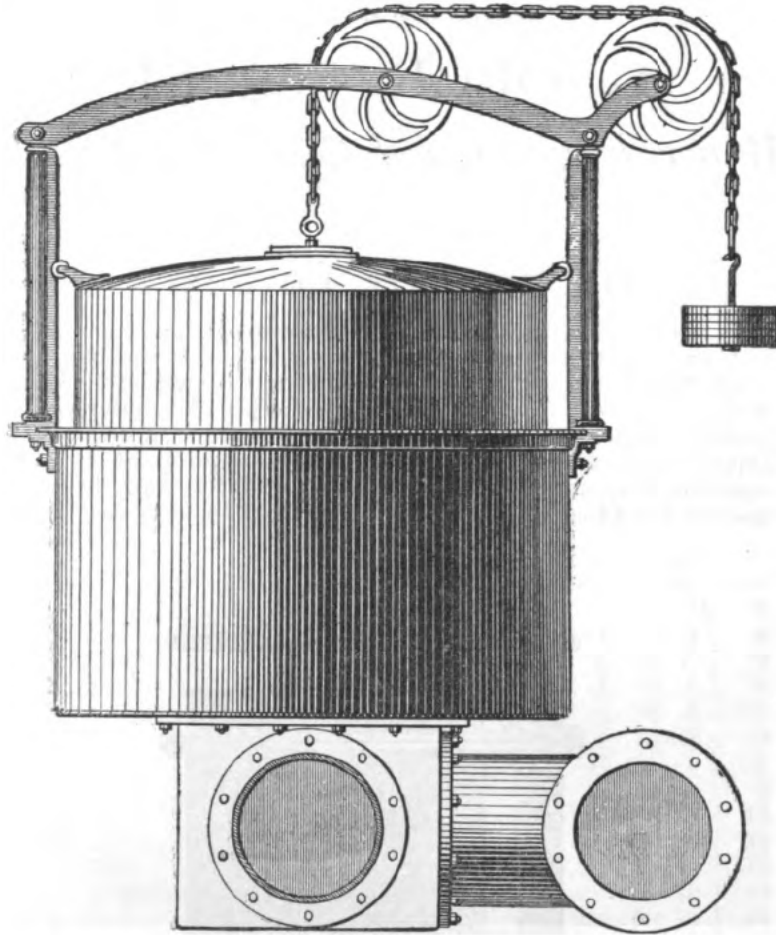

### THE PRESSURE REGISTER.

This instrument serves to record the degree of pressure delivered at the outlet of the works during the whole of the day and night; and, indeed, it records the action of the governor with which it is generally placed in connection, and, like that instrument, its action is automatic. The pressure register is formed by a closed tank, in which is a floated gas-holder, somewhat less than half the height of the tank; above the tank is a chamber, containing a vertical cylinder of about 15 inches long by 5 inches diameter, which is caused to rotate once in twenty-four hours by means of a clock on the top of the apparatus. On the cylinder is placed a paper ruled with twenty-four vertical lines, corresponding with the various hours of the day and night; there is also a number of horizontal lines corresponding with the  $\frac{1}{10}$ ths of pressure, and by these means the pressure at all hours can be recorded. For this object a rod is attached to the top of the floated holder, protruding through the centre of the top of the tank, and at the end of this rod is a pencil pressed by a light spring against the paper coiled on the cylinder. Hence, as the floated holder rises according to the degree of pressure, so does the pen mark this on the paper; and as the hours of this accord with those of the clock, the pressure in the main to which the instrument is attached is at all times indicated. The great desirability of these consists in their accuracy, and that in the event of any complaint of insufficient pressure at any time, when the manager or engineer is absent, the question is at once decided by reference to the table of the day in question.

#### NOTES.

It has been found, by experiment, that the pressure in a main varies at the rate of  $\frac{1}{100}$  of an inch for every foot of rise or fall. It is found practically that a district lying even 30 feet below the level of the works may be lighted without the intervention of a governor, as the diminution due to the difference of level would equal only  $\frac{1}{30}$  of an inch pressure. But governors are especially necessary in the case of towns having different stages of elevation, because the gas, as it reaches the higher parts of the towns, will act with so great a pressure as to produce very serious leakage in the pipes, besides the disadvantage of giving the upper districts an undue proportion of light at the expense of the lower. Separate governors for the regulation of pressure are not considered necessary, unless the ground has a rise of about 30 feet; and in order to carry out the principle of uniform pressure to the utmost advantage, there ought to be as many governors as the quotient of the whole elevation in feet divided by 30.—HUGHES.

GEORGE BOWER, ST. NEOTS, HUNTINGDONSHIRE.

[J]

# IMPROVED PATENT VALVES

FOR GAS, WATER, OR STEAM,

MANUFACTURED AND SUPPLIED BY

## GEORGE BOWER,

*Gas and Water Engineer and Contractor, St. Neots, Hunts.*

These Valves are constructed on the principle of an ordinary plug-cock, having divisions or passages arranged in the plug to suit the purpose for which the valve is required, and are provided with strong lids and stuffing-boxes through which the spindle passes; they are furnished also with gearing fixed on the covers, for raising or depressing the plugs, and which enables them to be more readily and easily worked than any other form of valve in use.

They are fitted in the most complete and substantial manner, with extra strong flanges for connecting, and, with the exception of the Through-Way Valves, are provided with dials, and index fingers to indicate the direction of the current of gas or fluid, so that no mistake can occur; provision is also made for the lubrication of the plugs without removing the covers or interfering with the working of the valves.

The principal advantages claimed for these valves are—

- 1st. Their non-liability to being rendered inoperative from corrosion or "sticking."
- 2nd. Their extreme simplicity, combined with great strength of parts and good workmanship.
- 3rd. Their compactness, the Centre and By-pass Valves especially requiring less than half the space occupied by any others made, which also enables them to be more directly connected to the Purifiers, or other vessels for which they are intended, thereby materially simplifying and reducing the quantity of connecting pipes.
- 4th. The vertical distance between the inlet and outlet branches of the Centre Valves, and the branches leading to and from the Purifiers, is considerably less than in ordinary Centre Valves, and the difference in the levels of the connecting pipes is consequently reduced.
- 5th. The covers can be removed for the inspection of the interior, and replaced in a few minutes.
- 6th. By a special arrangement of the Centre Change Valves, the gas may be conducted through the whole of the series of Purifiers in succession, or any one of them shut off at pleasure.

## THROUGH-WAY VALVES.

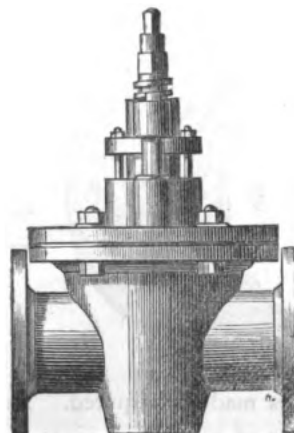
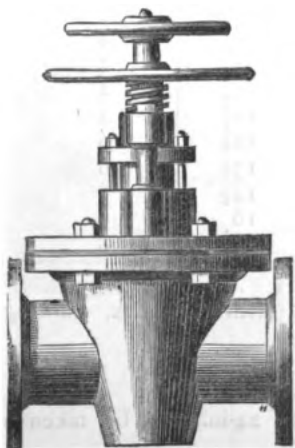

[see description on page 72.]

### THROUGH-WAY VALVES

(see Engravings on page 71)

Have a passage through them when open, of the full size of the main pipes to which they are attached, they are fitted with hand wheels or box keys as required. If provided with indicators for showing the extent to which they are open, an extra charge of per inch will be made.

**PROPORTIONS AND PRICES.**

| Size of Connecting Pipes | Extreme width from face to face of opposite Flanges on branches. | Diameter of Flanges. | Number of holes in each Flange. | Price. |    |    |
|--------------------------|------------------------------------------------------------------|----------------------|---------------------------------|--------|----|----|
| inches.                  | inches.                                                          | inches.              |                                 | £      | s. | d. |
| 2                        | 8                                                                | 6½                   | 4                               |        |    |    |
| 3                        | 10½                                                              | 7½                   | 4                               |        |    |    |
| 4                        | 12½                                                              | 8½                   | 4                               |        |    |    |
| 5                        | 13½                                                              | 9½                   | 4                               |        |    |    |
| 6                        | 15                                                               | 10½                  | 4                               |        |    |    |
| 7                        | 16                                                               | 12½                  | 6                               |        |    |    |
| 8                        | 18                                                               | 13½                  | 6                               |        |    |    |
| 9                        | 19                                                               | 14½                  | 6                               |        |    |    |
| 10                       | 21½                                                              | 16                   | 6                               |        |    |    |
| 11                       | 22                                                               | 17                   | 8                               |        |    |    |
| 12                       | 24                                                               | 18                   | 8                               |        |    |    |

### THROUGH-WAY SLIDE VALVES.

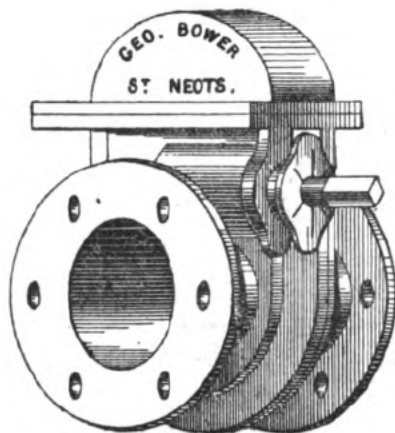

| Size of Connecting Pipes. | Extreme width from face to face of opposite Flanges on branches. | Diameter of Flanges. | Number of holes in each Flange. | Price. |    |    |
|---------------------------|------------------------------------------------------------------|----------------------|---------------------------------|--------|----|----|
| inches.                   | inches.                                                          | inches.              |                                 | £      | s. | d. |
| 2                         | 8½                                                               | 6½                   | 4                               |        |    |    |
| 3                         | 10½                                                              | 7½                   | 4                               |        |    |    |
| 4                         | 11½                                                              | 8½                   | 4                               |        |    |    |
| 5                         | 11½                                                              | 9½                   | 4                               |        |    |    |
| 6                         | 11½                                                              | 10½                  | 4                               |        |    |    |
| 7                         | 11½                                                              | 12½                  | 6                               |        |    |    |
| 8                         | 12½                                                              | 13½                  | 6                               |        |    |    |
| 9                         | 12                                                               | 14½                  | 6                               |        |    |    |
| 10                        | 13½                                                              | 16                   | 6                               |        |    |    |
| 12                        | 16                                                               | 18                   | 8                               |        |    |    |

These are made, if required, with an index, showing the extent to which the valve is open.

Larger sizes made if required. The price above 12-in., and up to 24-in., may be taken at per each inch in diameter of connecting pipes.

BY-PASS VALVES

Are arranged so as to form in one, "Four-way," "By-pass," and "Shut-off," for connecting to the Condenser, Washer, Scrubber, Station Meter, Exhauster, Governor, etc., and by which the gas may be passed through or shut off from these vessels, or they may be used as stop valves; they are fitted complete with plugs, dials, and index figures, etc.

PROPORTIONS AND PRICES.

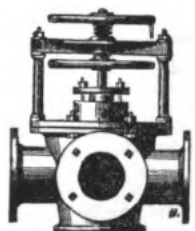

| Size of Connecting Pipes. | Extreme width from face to face of opposite Flanges on branches. | Diameter of Flanges. | Number of holes in each Flange. | Prices. |    |    |
|---------------------------|------------------------------------------------------------------|----------------------|---------------------------------|---------|----|----|
| inches.                   | inches.                                                          | inches.              |                                 | £       | s. | d. |
| 2                         | 7 $\frac{1}{2}$                                                  | 6 $\frac{1}{2}$      | 4                               |         |    |    |
| 3                         | 12                                                               | 7 $\frac{1}{2}$      | 4                               |         |    |    |
| 4                         | 14 $\frac{1}{2}$                                                 | 8 $\frac{1}{2}$      | 4                               |         |    |    |
| 5                         | 17 $\frac{1}{2}$                                                 | 9 $\frac{1}{2}$      | 4                               |         |    |    |
| 6                         | 19 $\frac{1}{2}$                                                 | 10 $\frac{1}{2}$     | 4                               |         |    |    |
| 8                         | 21                                                               | 13 $\frac{1}{2}$     | 6                               |         |    |    |
| 10                        | 21 $\frac{1}{2}$                                                 | 16 $\frac{1}{2}$     | 8                               |         |    |    |
| 12                        | 32 $\frac{1}{2}$                                                 | 18                   | 8                               |         |    |    |

Prices for larger sizes on application.

CENTRE VALVES FOR 2 AND 3 PURIFIERS

Are so arranged that any Purifier may be shut off, and when re-charged with fresh purifying material, the gas can be conducted through each in succession, commencing with either one; they are provided with syphon boxes, pipes, and plugs, etc.

PROPORTIONS AND PRICES OF VALVES FOR 2 PURIFIERS.

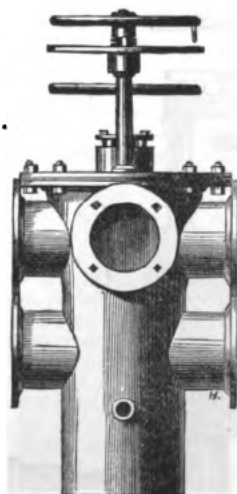

| Size of Connecting Pipes. | Extreme width from face to face of opposite Flanges on branches. | Diameter of Flanges. | Number of holes in each Flange. | Vertical distance between inlet and outlet branches and branches to and from Purifiers. | Prices. |    |    |
|---------------------------|------------------------------------------------------------------|----------------------|---------------------------------|-----------------------------------------------------------------------------------------|---------|----|----|
| inches.                   | inches.                                                          | inches.              |                                 | inches.                                                                                 | £       | s. | d. |
| 3                         | 15                                                               | 7 $\frac{3}{4}$      | 4                               | 7 $\frac{3}{4}$                                                                         |         |    |    |
| 4                         | 16 $\frac{1}{2}$                                                 | 8 $\frac{1}{4}$      | 4                               | 8 $\frac{1}{4}$                                                                         |         |    |    |
| 5                         | 18                                                               | 9 $\frac{1}{2}$      | 4                               | 9 $\frac{1}{2}$                                                                         |         |    |    |
| 6                         | 21                                                               | 10 $\frac{3}{4}$     | 4                               | 11                                                                                      |         |    |    |
| 8                         | 25                                                               | 13 $\frac{3}{4}$     | 6                               | 14                                                                                      |         |    |    |

PROPORTIONS AND PRICES OF VALVES FOR 3 PURIFIERS.

| inches. | inches. | inches.          |   | inches.          | £ | s. | d. |
|---------|---------|------------------|---|------------------|---|----|----|
| 3       | 18      | 7 $\frac{3}{4}$  | 4 | 8                |   |    |    |
| 4       | 24      | 8 $\frac{1}{4}$  | 4 | 9                |   |    |    |
| 5       | 24      | 9 $\frac{1}{2}$  | 4 | 10               |   |    |    |
| 6       | 27      | 10 $\frac{3}{4}$ | 4 | 11 $\frac{1}{2}$ |   |    |    |
| 8       | 31      | 13 $\frac{3}{4}$ | 6 | 14               |   |    |    |
| 9       | 33      | 14 $\frac{3}{4}$ | 6 | 15               |   |    |    |
| 10      | 34      | 16               | 8 | 16 $\frac{1}{2}$ |   |    |    |

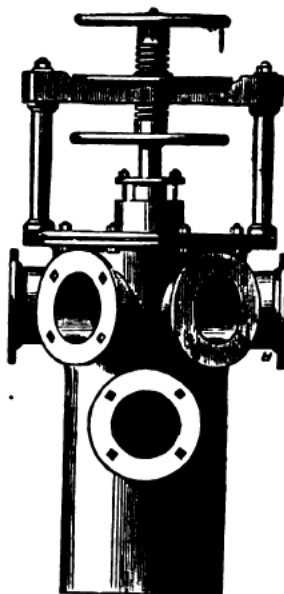

CENTRE VALVE  
FOR  
2 PURIFIERS.

CENTRE VALVE  
FOR  
3 PURIFIERS.

### CENTRE VALVES FOR 4 PURIFIERS

Are arranged to pass the gas through any three Purifiers in succession, the fourth being shut off for renewal of the purifying material; they are fitted complete.

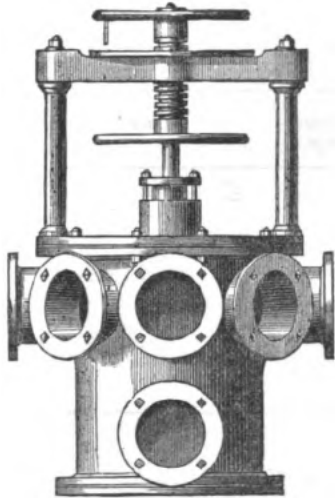

PROPORTIONS AND PRICES.

| Size of Connecting Pipes. | Extreme width from face to face of opposite Flanges on branches. | Diameter of Flanges. | Number of holes in each Flange. | Vertical distance between inlet and outlet branches, and branches to and from Purifiers. | Price.  |
|---------------------------|------------------------------------------------------------------|----------------------|---------------------------------|------------------------------------------------------------------------------------------|---------|
| inches.                   | inches.                                                          | inches.              |                                 | inches.                                                                                  | £ s. d. |
| 3                         | 18                                                               | 7 $\frac{3}{4}$      | 4                               | 8                                                                                        |         |
| 4                         | 22                                                               | 8 $\frac{1}{4}$      | 4                               | 9                                                                                        |         |
| 5                         | 23 $\frac{1}{2}$                                                 | 9 $\frac{1}{2}$      | 4                               | 10                                                                                       |         |
| 6                         | 26 $\frac{1}{2}$                                                 | 11                   | 4                               | 11 $\frac{1}{2}$                                                                         |         |
| 8                         | 36                                                               | 13 $\frac{1}{2}$     | 6                               | 14                                                                                       |         |
| 9                         | 39                                                               | 14 $\frac{1}{2}$     | 6                               | 15                                                                                       |         |
| 10                        | 49                                                               | 16 $\frac{1}{2}$     | 8                               | 16 $\frac{1}{2}$                                                                         |         |
| 12                        | 51 $\frac{1}{4}$                                                 | 18                   | 8                               | 20                                                                                       |         |

### COMPOUND CENTRE VALVES FOR 4 PURIFIERS.

By this arrangement the gas may be passed through the four Purifiers in succession, or shut off from any one of them; thereby making the whole of the purifying surface available. They are provided with syphons as shewn on the inlet and outlet pipes.

PROPORTIONS AND PRICES.

| Size of Connecting Pipes. | Extreme width from face to face of opposite Flanges on branches. | Diameter of Flange. | Number of holes in each Flange. | Prices. |
|---------------------------|------------------------------------------------------------------|---------------------|---------------------------------|---------|
| inches.                   | inches.                                                          | inches.             |                                 | £ s. d. |
| 3                         | 21                                                               | 7 $\frac{3}{4}$     | 4                               |         |
| 4                         | 25                                                               | 8 $\frac{1}{4}$     | 4                               |         |
| 5                         | 32                                                               | 9                   | 4                               |         |
| 6                         | 39                                                               | 10 $\frac{1}{2}$    | 4                               |         |
| 8                         | 49                                                               | 13 $\frac{1}{2}$    | 6                               |         |
| 9                         | 52                                                               | 14 $\frac{1}{2}$    | 6                               |         |
| 10                        | 60                                                               | 16 $\frac{1}{2}$    | 8                               |         |
| 12                        | 69 $\frac{1}{4}$                                                 | 18                  | 8                               |         |

Prices for larger sizes of any of these valves given on application. Flange and Spigot, or Flange and Socket connections, supplied at per inch each. These valves can be supplied, fitted with brass plugs, or brass faces, at an extra cost of from to per inch.

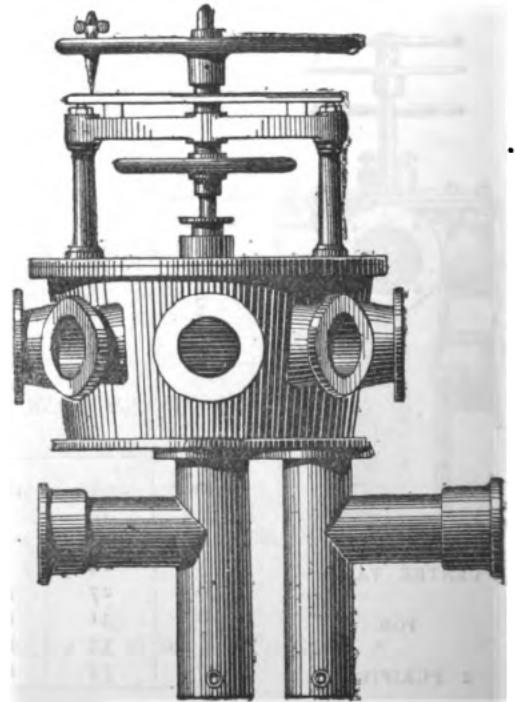



[K]

## EXPERIMENTAL APPARATUS,

SUPPLIED BY

GEORGE BOWER,

*Gas and Water Engineer and Contractor, St. Neots, Hunts.*

## APPARATUS FOR TESTING THE QUALITY AND ILLUMINATING POWER OF GAS.

In the preceding Sections have been described the whole of the apparatus necessary for the manufacture of coal gas, but before proceeding to detail the manner of distribution it may be well to give particulars and description of the apparatus for testing the quality and ascertaining the illuminating power of the gas manufactured, as well as of other instruments which are considered necessary on works of any importance.

The approximate or commercial value of coal gas is determined in several ways:—

1st. By the *Photometer*, which will be minutely described in this Section.

2nd. *The Chlorine Test*.—The mode of conducting the experiment is this:—A quantity of gas is to be let up into a graduated tube over water; the tube is then to be covered so as to exclude light, and chlorine is to be passed up into it. After standing for ten or fifteen minutes in the dark, the excess of chlorine is to be absorbed by potash, and the amount of absorption read off. The larger the quantity absorbed, the better the gas. This will range from three to twenty per cent. The matters absorbed by the chlorine are the condensable hydro-carbons, which are the illuminating principles of the gas.

3rd. *The Bromine Test*.—Many years ago, M. Balard showed that bromine had the power of absorbing olefiant gas, and that in this respect, as in most others, it was like chlorine. Lately, Mr. Lewis Thompson has taken advantage of this property, and has made it the means of discovering the quality of coal-gas. The reactions of bromine on gas are exactly the same as those of chlorine; but it has an advantage over the latter, in the circumstance that it is much more manageable, that it is more likely to be pure, and that the admission of light does not affect the results. In manipulating with this body, we fill a graduated tube, called a Cooper's tube, with gas, and then pour into the shorter leg of the instrument a small quantity of a saturated solution of bromine in water, taking care to use enough to give the gas an orange-red colour. After the mixture has been shaken, the tube is allowed to stand for about ten minutes, and then the excess of bromine is to be absorbed by means of potash; after which, the amount of absorption is noted. As in the last case, this will range between three and twenty per cent., according to the quality of the gas.

4th. *The Sulphuric Acid Test*.—Professor Faraday long since observed, that when concentrated sulphuric acid was brought into contact with the condensable hydro-carbons, it speedily absorbed them. Relying upon this fact, Professor Bunsen has recommended that fuming, or anhydrous acid, should be employed for the purpose of ascertaining how much of these agents is present in coal-gas. Messrs. Leigh and Frankland have spoken well of the results obtained in this manner; but however successful the process may be in their hands, it is open to many fallacies, and cannot therefore be recommended to the unskilled operator. The mode of experimenting is this:—The gas is to be collected in a graduated tube, over mercury; and then a piece of coke or pumice-stone, fastened to a platinum wire, and moistened, or rather saturated with the acid, is to be passed up into the gas; after remaining in contact with it for ten minutes or a quarter of an hour, the coke is to be withdrawn; and as a small quantity of sulphurous acid will have been formed by the action of the coke upon the mercury, the gas is to be washed with a little potash, and then the amount of the absorption noted. Sulphuric acid does not, however, attack all the hydro-carbons; for it is found that chlorine or bromine will effect a further condensation after the action of the acid. This, with other circumstances, renders the process objectionable.

5th. *The Specific Gravity Test*.—This is founded on the fact that the rich hydro-carbons are much heavier than the poor ones; for example, if a given bulk of marsh gas, or light carburetted hydrogen, weighs 10 grains, the same bulk of olefiant gas will weigh 17½ grains; and in the case of the other hydro-carbons, the increase in weight is still greater. A knowledge of this fact will enable us to ascertain the value of any description of gas. We take a glass globe or flask, fitted air-tight to a stop-cock, and exhaust it with great care by means of an air-pump; then let in pure and dry hydrogen, and again exhaust. Do this a third or even a fourth time, so as to get the flask as empty of air as possible; then weigh in a delicate balance, and note the amount; pure and dry atmospheric air is now to be admitted, and the flask is to be weighed again. In this manner we ascertain how much of pure dry air, at a temperature of 60° Fahr. and a pressure of 30 inches of the barometer, it contains. When we wish to take the specific gravity of any gas, the globe is to be exhausted as before, then filled with the gas, and weighed; corrections are to be made for any abnormal difference of temperature or pressure; and then we say, as the weight of the vessel full of air is to 1, so is the weight of the gas to its specific gravity. In practice, it will be found convenient to have a globe with two stop-cocks, one opposite the other; so that after the first exhaustion and weighing, the globe can be easily filled with gas without the aid of air pump, by simply allowing the gas to pass through it for about a quarter of an hour. Mr. Wright has constructed an apparatus which still further simplifies this calculation. It consists of an oiled silk balloon, that holds 1000 cubic inches of gas; and as coal gas is lighter than air, he determines its specific gravity by ascertaining the number of grains which the balloon will carry up. A book that accompanies the apparatus contains instructions for the management of the experiment. The specific gravity of coal gas ranges between .390 and .750. The former is about the weight of the worst gas from Garesfield coals, and the latter of the best from Boghead canal; a good average of specific gravity is .450. In conducting experiments of this kind, it must be ascertained that the gas does not contain carbonic acid, carbonic oxide, or atmospheric air, for if it does, the specific gravity of the gas is sure to be high, notwithstanding that the illuminating power may be very low.

Before we leave this part of the subject, it may be remarked, that if the specific gravity of gas is taken before its condensation by bromine, and then again afterwards, the difference in weight will afford a means of ascertaining the specific gravity of the condensed portion; and if this be multiplied by the amount of condensation, we obtain a number that represents very nearly the illuminating power of the gas in sperm candles, as it is usually expressed. For example, a gas of specific gravity .447 has a condensation of 5 per cent. and the residual gas has a specific gravity of .328. Now since 100 cubic inches of the former weigh 13.63 grains, and 95 cubic inches of the latter 9.5 grains, the 5 cubic inches of the condensed portion must weigh 4.13 grains, and it must have had a specific gravity of 2.7. This, multiplied by 5, the amount of condensation, gives 13.5 as the illuminating power of the gas. Experiment showed it to be 14.

## THE PHOTOMETER.

The Photometer, or Light Measurer, is an instrument by which a comparison is made between the light evolved from a lamp, or candle, burning a known quantity of oil, sperm, or wax, and a burner consuming a given quantity of gas.

To ascertain the illuminating power of gas, the standard adopted in England and most other places is the sperm candle, consuming 120 grains of sperm per hour, of which candles a given number is compared with a particular description of Argand burner, called the "standard burner," consuming 5 cubic feet of gas per hour. The quality of gas as defined by the different Acts of Parliament, which control the operations of companies, is variable, ranging from 12 candles upwards, the average for English companies being 14 candles; that is, gas of the quality that 5 cubic feet will give the light of the number of candles stated, or, as technically termed, "14 candle gas."

The companies in Scotland invariably supply gas of a very superior quality, which at the lowest may be estimated at "22 candle gas."

In order to describe the action of the Photometer, it must be first observed that the power of light diminishes inversely as the square of the distance from the point where the light is produced.

Thus, if we suppose the light at the distance of one foot from its source to be one, then at two feet it would be *one-fourth*, at three feet *one-ninth*, and at five feet, *one twenty-fifth* part, arising from the circumstance that the square of two is four, which inversed gives *one-fourth* of one, the square of 3 is 9, and this inversed gives *one-ninth*, and so forth. And on this line the scale or measure of the Photometer is based.

The first Photometer was constructed by Count Romford, who adopted the plan of adjusting the light under examination at such a distance from a perpendicular rod that the shadows produced by each light on a white screen should be of the same intensity, which was obtained by moving the lesser light to and fro until the exact point was determined. This accomplished, the distances between the respective lights and the screen were measured, when the square of the greater distance was divided by the square of the lesser distance, which gave the proportion between the two lights. Thus, if we suppose an investigation being made with gas and a candle, and the gas to be 100 inches from the screen, and the candle to produce a shadow of like intensity to the gas, to be a distance of 25 inches from the screen, then the square of the former divided by that of the latter number will give 16 as the product, or the gas would be equal to 16 candles.

The Photometer, as usually employed, consists of a graduated bar, supported at the ends, as represented in the accompanying engraving. The burner is fixed, and provided with two taps, one of which is for the purpose of adjusting the gas to the required quantity. The candle is fixed a distance of 10 inches from the screen, on the frame which carries the screen, and glides freely to and fro on the bar, when seeking the point of equality between the two lights. One of the advantages of this system is the shorter bar which is required, this being about 5 feet instead of 8 feet 4 inches, as usually made. The disc is a piece of white filtering paper, placed in its frame, with the dark annular space saturated with spermacetti, the centre being left untouched; this is placed within, and at the centre of the screen, with the gas burner consuming the necessary quantity, and the candle of the required material and size, the whole is ready for operation. It is, however, desirable that both the gas and the candle should be lighted at least ten minutes before commencing operations, otherwise the burner, on becoming heated, will deliver more gas than it is at first adjusted to; the candle also becomes more suitable for action.

All being ready, the operator observes, by the two orifices in front of the screen, the state of the disc, and usually the manner adopted is to place it so as to be rendered transparent by the gas burner, and then advancing it gradually towards the candle, until the centre spot disappears, when by observing the pointer immediately beneath the disc, the number of candles the gas is equivalent to is indicated on the bar. It is advisable always to make at least three trials, to sum up the total, and take the mean.

For the more accurate working a small regulator is requisite, to adjust the pressure of the gas supplied to one uniform degree, and thus avoid any variations arising from alterations of the pressure in the mains. A minute clock, with experimental meter, showing the hourly rate of consumption by an observation of a minute, are also necessary where many observations are required.

Further, to be successful in Photometry, other details are necessary to be observed, for although manufacturers make the candles as near as possible to consume 120 grains per hour, yet, with all their care, a considerable variation in this respect will always exist; therefore, when making experiments the candle should be previously weighed, the time accurately noted that it is burning during the operation, and it should be again re-weighed on the conclusion of the experiment, and calculated to the proper standard. In some cases, instead of the candles consuming 120 grains, they exceed 130 per hour, therefore the necessity for weighing is evident. A considerable degree of care is also essential in defining the point where the spot on the disc disappears; and, indeed, like every other operation, Photometry requires some practice.

The engravings given are of the most recent and improved Photometers, with the accessory instruments recommended, of which full details are given.

### WILLIAM SUGG'S 60-INCH BAR PHOTOMETER, ON DR. LETHEBY'S SYSTEM.

*Fitted in accordance with the requirements of the Gas Referees for London.*

This Photometer must be fixed in a dark room, size not less than 10 ft. by 12 ft. Length of bench, 11 ft. by 2 ft. 3 in.

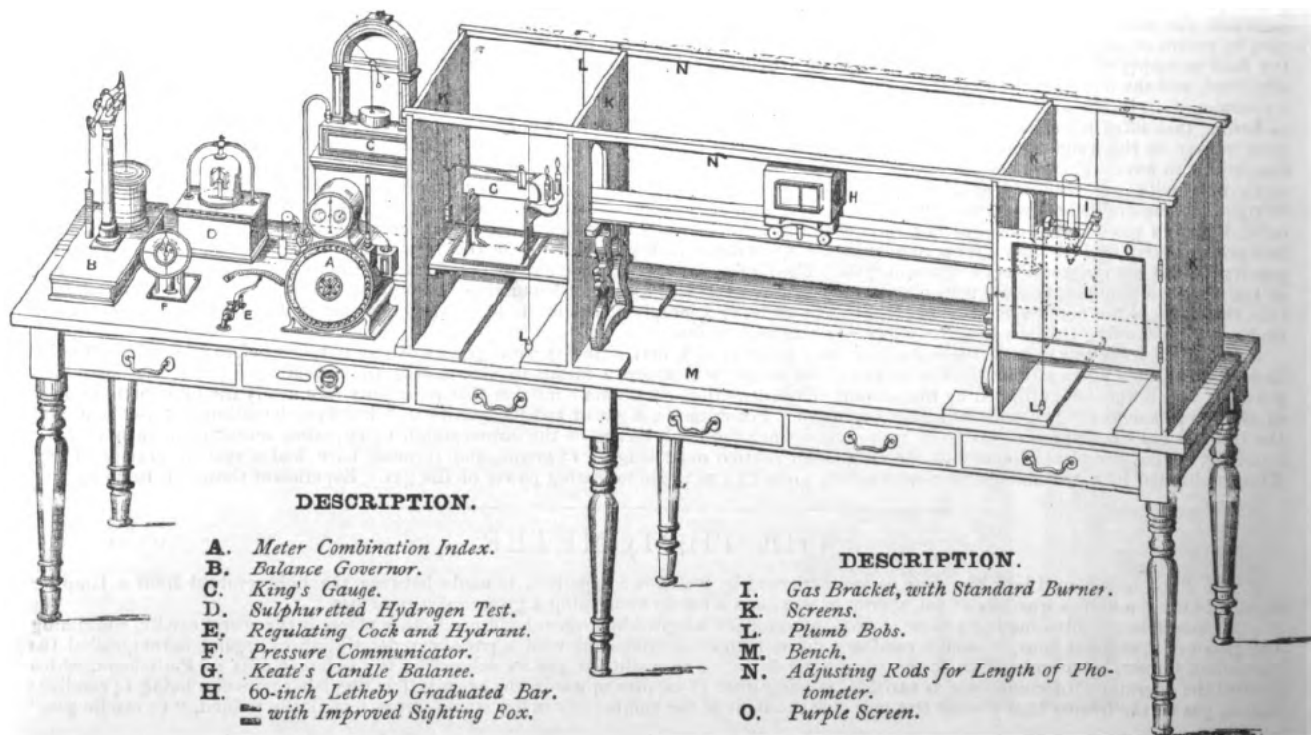

#### DESCRIPTION.

- A. Meter Combination Index.
- B. Balance Governor.
- C. King's Gauge.
- D. Sulphuretted Hydrogen Test.
- E. Regulating Cock and Hydrant.
- F. Pressure Communicator.
- G. Keat's Candle Balance.
- H. 60-inch Letheby Graduated Bar.
- I. with Improved Sighting Box.

#### DESCRIPTION.

- I. Gas Bracket, with Standard Burner.
- K. Screens.
- L. Plumb Bobs.
- M. Bench.
- N. Adjusting Rods for Length of Photometer.
- O. Purple Screen.

GEORGE BOWER, ST. NEOTS, HUNTINGDONSHIRE.

The instrument illustrated on the preceding page represents the 60-inch Bar Photometer on Dr. Letheby's system, as manufactured by Mr. William Sugg. This instrument requires a darkened room, and is fitted up in accordance with the requirements of the Gas Referees for London. Prices of this instrument, and the requisite fittings, are given in the Companion to this book.

A very similar instrument is also made by the same gentleman, which is so arranged as not to require a dark room; but the former, in the opinion of the writer, is to be preferred.

AMMONIA TESTING APPARATUS AND MATERIAL.

|                                                                                                                                                    | £ | s. | d. |                                                    | £ | s. | d. |
|----------------------------------------------------------------------------------------------------------------------------------------------------|---|----|----|----------------------------------------------------|---|----|----|
| Dr. Letheby's Ammonia tube (double) on mahogany stand, filled with glass beads, and fitted with ground glass cocks, and india rubber tube complete |   |    |    | One 200-septem pipette .. .. .                     |   |    |    |
| Half-gallon solution of sulphuric acid, 100 septems of which will neutralise 10 grains of ammonia ..                                               |   |    |    | One 50 ditto ditto .. .. .                         |   |    |    |
| Half-gallon Ammonia solution, 100 septems containing one grain Ammonia .. .. .                                                                     |   |    |    | Two half-pint beakers .. .. .                      |   |    |    |
| Half-pint tincture Hematine in stoppered bottle ..                                                                                                 |   |    |    | One conical testing beaker .. .. .                 |   |    |    |
|                                                                                                                                                    |   |    |    | One 2 decigallon flask .. .. .                     |   |    |    |
|                                                                                                                                                    |   |    |    | One Mohr's Burette, 100 at top, and 0 at bottom .. |   |    |    |
|                                                                                                                                                    |   |    |    | One mahogany clamp for ditto .. .. .               |   |    |    |
|                                                                                                                                                    |   |    |    | One glass stirrer .. .. .                          |   |    |    |

SULPHURETTED HYDROGEN TESTING APPARATUS.

|                                                                                  | £ | s. | d. |                                                   | £ | s. | d. |
|----------------------------------------------------------------------------------|---|----|----|---------------------------------------------------|---|----|----|
| One "Gas Referees" Sulphuretted Hydrogen Test on mahogany stand complete .. .. . |   |    |    | One dozen books Turmeric test papers per dozen .. |   |    |    |
|                                                                                  |   |    |    | One dozen books acetate of lead .. .. .           |   |    |    |

SULPHUR TESTING APPARATUS.

|                                                                                                                                                                                                                                                                                                                                                                                                                                                                                                                                                                                                                                                         | £ | s. | d. |                                                      | £ | s. | d. |
|---------------------------------------------------------------------------------------------------------------------------------------------------------------------------------------------------------------------------------------------------------------------------------------------------------------------------------------------------------------------------------------------------------------------------------------------------------------------------------------------------------------------------------------------------------------------------------------------------------------------------------------------------------|---|----|----|------------------------------------------------------|---|----|----|
| One "Gas Referees" Sulphur Test complete, consisting of 1 condensing cylinder, filled with about 200 glass balls, 1 trumpet tube, 1 long straw tube, 1 burner with perforated regulator for the admission of air, steam-tight tin and table for carbonate of ammonia, 1 black polished pine stand, 1 beaker for collecting liquid from the condensing cylinder, 1 glass tube with india rubber for attaching to bottom of condensing cylinder, to convey the condensed liquid into the beaker, 4 adjusting pieces for regulating the position of the burner, 2 india rubber connections, one for the trumpet tube, the other for the straw tube .. .. . |   |    |    | Two Bunsen burners, tripods, and gauze .. .. .       |   |    |    |
| One Experimental Meter, with stop action to shut off when 10 cubic feet of gas has passed through it, capacity of measuring drum 1/100th of a cubic foot, the index showing from the 100th of a foot to 1000 cubic feet, fitted with levelling plate, glass water line gauge and thermometer box .. .. .                                                                                                                                                                                                                                                                                                                                                |   |    |    | Two tin filter drainers .. .. .                      |   |    |    |
| Without stop action .. .. .                                                                                                                                                                                                                                                                                                                                                                                                                                                                                                                                                                                                                             |   |    |    | Six test tubes and stand .. .. .                     |   |    |    |
| One thermometer in brass case for ditto .. .. .                                                                                                                                                                                                                                                                                                                                                                                                                                                                                                                                                                                                         |   |    |    | Six pipe-clay triangles .. .. .                      |   |    |    |
| One small spirit level for ditto .. .. .                                                                                                                                                                                                                                                                                                                                                                                                                                                                                                                                                                                                                |   |    |    | Six sheets glazed black paper .. .. .                |   |    |    |
| One double dry governor, mounted on brass pillar for maintaining uniformity of pressure during experiments .. .. .                                                                                                                                                                                                                                                                                                                                                                                                                                                                                                                                      |   |    |    | Two hundred cut 4-inch filter paper, 1s. 3d. per 100 |   |    |    |
| Twelve feet red india rubber tubing (1/2-inch) .. .. .                                                                                                                                                                                                                                                                                                                                                                                                                                                                                                                                                                                                  |   |    |    | One wash bottle .. .. .                              |   |    |    |
| One balance in glass case to turn to 1/100th of a grain and carry a weight of 1000 grains in each pan ..                                                                                                                                                                                                                                                                                                                                                                                                                                                                                                                                                |   |    |    | One 20-ounce measure, divided into 1/4 ounce .. ..   |   |    |    |
| One set of grain weights from 1,000 grains to 1/100th of a grain in box .. .. .                                                                                                                                                                                                                                                                                                                                                                                                                                                                                                                                                                         |   |    |    | Three 20-ounce beakers .. .. .                       |   |    |    |
| One drying oven in tinned iron, with connections for gas inside, two doors and glass front .. .. .                                                                                                                                                                                                                                                                                                                                                                                                                                                                                                                                                      |   |    |    | One 10-ounce flask, graduated .. .. .                |   |    |    |
| Brackets for fixing against wall and shelf for carrying ditto .. .. .                                                                                                                                                                                                                                                                                                                                                                                                                                                                                                                                                                                   |   |    |    | Three 9-inch stirring rods .. .. .                   |   |    |    |
| One desiccator on stand .. .. .                                                                                                                                                                                                                                                                                                                                                                                                                                                                                                                                                                                                                         |   |    |    | Three 4 1/2 clock glasses .. .. .                    |   |    |    |
| One 1-ounce platinum crucible and lid .. .. .                                                                                                                                                                                                                                                                                                                                                                                                                                                                                                                                                                                                           |   |    |    | Two 20-ounce narrow-mouthed stoppered bottles ..     |   |    |    |
| One pair crucible tongs, platinum points .. .. .                                                                                                                                                                                                                                                                                                                                                                                                                                                                                                                                                                                                        |   |    |    | Three 3-inch funnels .. .. .                         |   |    |    |
| Two mahogany filter stands, single ring .. .. .                                                                                                                                                                                                                                                                                                                                                                                                                                                                                                                                                                                                         |   |    |    | Three 10-ounce beakers .. .. .                       |   |    |    |
|                                                                                                                                                                                                                                                                                                                                                                                                                                                                                                                                                                                                                                                         |   |    |    | Two 8-ounce narrow-mouthed stoppered bottles ..      |   |    |    |

CHEMICALS FOR DITTO.

Chloride of Barium, 2 lbs; Pure Hydrochloric Acid, 1 quart; Carbonate of Ammonia, 4 lb.; Commercial Sulphuric Acid 1 pint; Crystallized Nitrate of Silver; two dozen books red or blue litmus papers; with stoppered bottles, jars, &c. Sugg's Table for ascertaining quantity of sulphur .. Method of Testing for Ammonia and Sulphur .. Forms for Sulphur and Ammonia Tests, 250 bound ..

Note:—

THE PRESSURE REGISTER

Will be found described on page 49

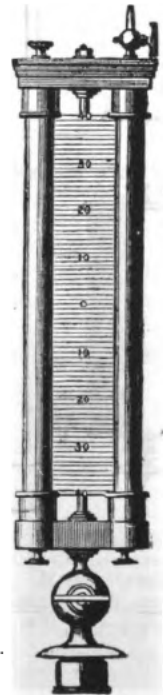

PRESSURE GAUGES.

This very necessary and useful instrument is constructed in various forms, the simplest consists of a bent glass tube, one end being open to the air, and the other end connected to the gas supply; it is partly filled with water, which, when the pressure is off it, stands at the same level in both legs; the space, both above and below this line or level, is divided into inches and tenths of an inch. When the gas is turned on, the water is depressed in the one leg and raised in the other, the reading being equal to the sum of the indications on each leg when added together.

Pressure Gauges should be fixed in connection with every separate portion of the Apparatus, namely, from outlet from hydraulic main, scrubber, inlet and outlet pipes of exhauster, outlet from purifiers, meter, and governor.

The accompanying engraving shows a very suitable form of the instrument. The cap piece is fitted with an air plug and jet cock, and the bottom with cock and union for connecting to gas tubes, also two small plugs for regulating the level of the water in the tubes.

GEORGE BOWER, ST. NEOTS, HUNTINGDONSHIRE.

## LOWE'S JET PHOTOMETER

(KIRKHAM AND SUCC'S IMPROVEMENTS.)

This very complete and compact Apparatus is fitted with Water Line Regulator; Improved Micrometer with Quadrant divided into 45 degrees; Valve with *pro rata* opening; Improved Ventilator; Purple Glass, height of Flame Measurer; King's Gauge, working on Friction Rollers, in French polished pine case. Diagram for finding the illuminating power in candles.

Price - - - - - complete.

They can also be had with additional scale on Pressure Gauge, to show by inspection the illuminating power in sperm candles, at the extra cost of 10s.

*Note.*—When an order is given for a Jet Photometer with latter addition, it will be necessary to state about the quality of gas for which it will be used. The range in candles will not be more than 3 or 4.

Instructions for fixing the Jet Photometer, putting it into working order, and for taking observations, are sent with the instrument.

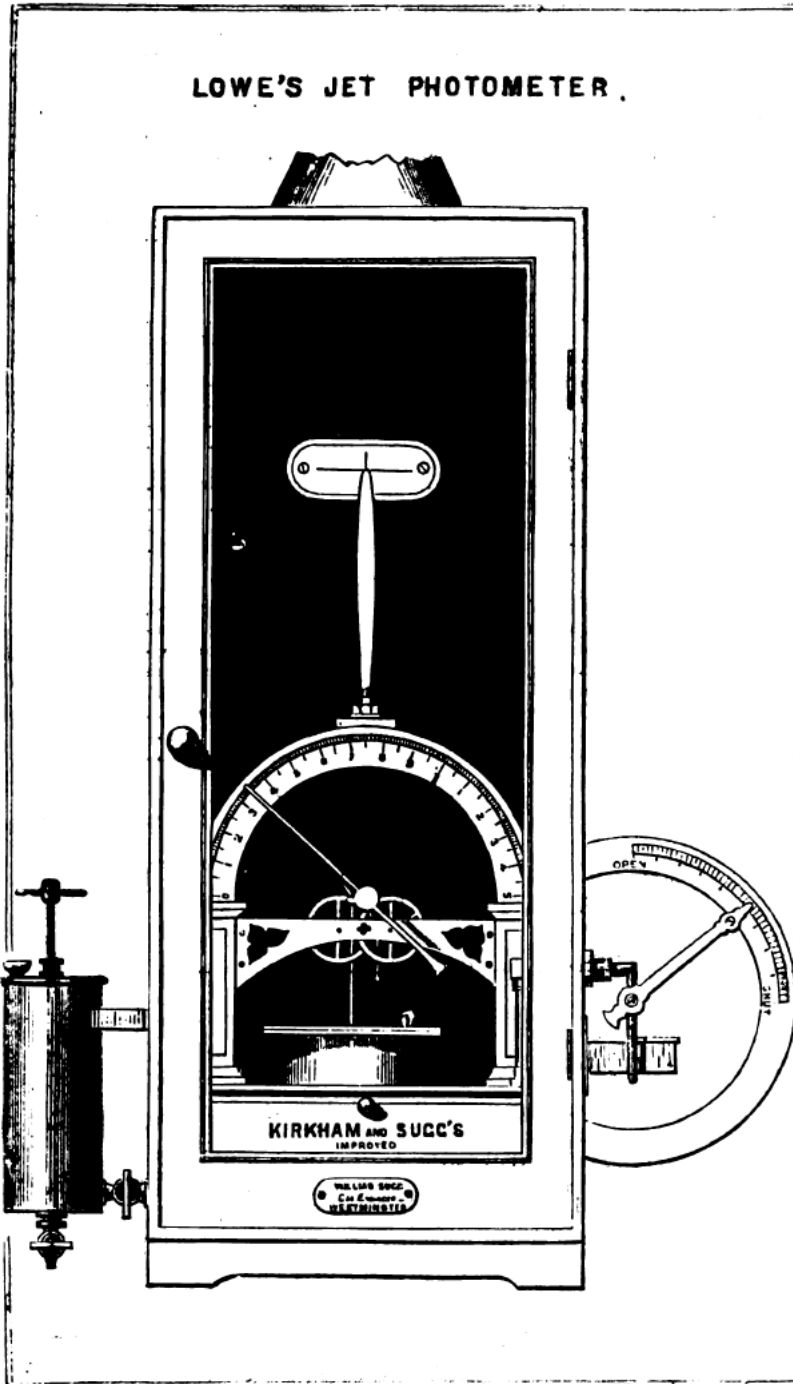

LOWE'S JET PHOTOMETER.

THE BUNSEN PHOTOMETER, WITH GRADUATED SCALE, COMPLETE, ETC.

HYDROMETERS.

SPECIFIC GRAVITY APPARATUS.

ALKALIMETERS, FOR ASCERTAINING THE STRENGTH OF AMMONIACAL LIQUOR.

APPARATUS FOR DETERMINING THE HEATING POWER OF COAL, AND OTHER DESCRIPTIONS OF FUEL.

HYGROMETERS.

BISULPHURET OF CARBON TEST APPARATUS.

SOLDER.

BROMINE TEST APPARATUS, WITH GRADUATED TUBE AND EQUALISING CYLINDER.

SCALES AND GRAIN WEIGHTS, FOR WEIGHING CANDLES IN EXPERIMENTS.

BAROMETERS.

STANDARD SPERM CANDLES.

STANDARD ARGAND AND OTHER BURNERS.

BALANCES FOR CHEMICAL ANALYSIS.

THERMOMETERS.

*Every Description of Apparatus required for Experimenting on Gas.*

GEORGE BOWER, ST. NEOTS, HUNTINGDONSHIRE.

[L]

# SPECIFICATIONS OF COAL GAS APPARATUS,

MANUFACTURED BY

GEORGE BOWER,

*Gas and Water Engineer and Contractor, St. Neots, Hunts.*

CONSISTING OF:—

*First.*—Details of Patent Portable Gas Apparatus for experimental purposes, and of apparatus for the supply of gas to villas, mansions, railway stations, and factories; and

*Secondly.*—Those for the supply of gas to villages, towns or cities, the two embracing works of a manufacturing capacity from 40 cubic feet to 80,000 cubic feet of gas per day.

These Specifications have been prepared for the purpose of enabling those persons desirous of erecting Gas-works to ascertain the size most suitable to their requirements, and the expenditure involved; sufficient details being given to enable engineers, and other persons resident abroad, to order the Apparatus without the necessity of further correspondence.

The Specifications do not include the buildings, or building work of any description required in the erection of any part of the Apparatus, as, in most cases, these are more economically performed by local builders, and from the fact that the buildings may vary so much in design as to make estimates unreliable; but at the foot of each specification will be found the approximate cost of the buildings indispensable for each works, erected in a plain and substantial manner.

Cases, however, frequently occur in this country where it is preferred that only one person should be responsible for the whole work; in which case, estimates will be given for the building and apparatus complete, or, if preferred, plans, elevations, and specifications will be provided, and the building work let by contract or otherwise, and the responsibility and supervision of the whole undertaken on the usual professional terms.

Although these specifications have been arranged in sizes of apparatus which experience has shown to be most convenient, there is no objection to a modification or substitution of part of the details of one for that of another of approximate capacity to suit special circumstances, and for this the alteration in cost will be given on application.

Plans and tenders in detail are also prepared for larger works and apparatus than those specified, and tenders will be given for works or apparatus to the plans of engineers, architects, &c., and in special cases plans and specifications will be furnished where it may not be convenient for engineers and architects to prepare them themselves.

## PRICES.

It will be noticed that these are given in the one case for the Apparatus packed, marked, and delivered free for export at any one of the several ports named, in which is included complete detailed lists of the whole of the materials, and general plans to facilitate its erection. It is, however, recommended where ordinary skilled labour is unattainable, that an experienced workman should be sent to superintend and direct the work.

In the other case, prices include the delivery at the railway station nearest to my Works, and the erection complete in this country, exclusive of any buildings, building work, excavation, or scaffolding, unless such have been specially contracted or arranged for, as previously described.

The supply of Fire Bricks, &c., are not included in the prices quoted, excepting only in the 1st Section comprising Specifications No.'s 02 to 42 inclusive.

## SPECIAL CONDITIONS TO BE OBSERVED WHEN AN ORDER IS GIVEN FOR A GAS WORKS TO BE ERECTED IN ENGLAND.

The Buildings and Tanks to be ready for the workmen when sent for; the Gasholder tank to be kept empty until the Gasholder is fixed. Scaffolding to be provided for the men; and the Apparatus, tools, and men, to be fetched from and returned to the nearest railway station. Where the order is for export, instructions and working plans are sent for erecting the works. If the Retorts are required to be constructed so as to be equally applicable for coal, wood, peat, or oil, the cost will be about 10 per cent. extra. In inquiring for prices, it is necessary to give the maximum number of lights, and the longest time they will be required to burn during winter nights.

GEORGE BOWER, ST. NEOTS, HUNTINGDONSHIRE.

SPECIFICATIONS OF APPARATUS FOR THE MANUFACTURE OF COAL GAS.

CAPABLE OF PRODUCING, FROM THREE CHARGES OF THE RETORTS, SUFFICIENT GAS TO SUPPLY THE NUMBER OF BURNERS FOR THE TIME STATED.

|                                                                                                                                                       | <i>No. 0a Apparatus</i><br><i>To manufacture for, and supply with coal gas, 8 burners for 4 hours per day, each burner giving a light equal to 10 ordinary candles.</i>                                                                                                                                                                                                                                                                                                                                                                                                   | <i>No. 1a Apparatus</i><br><i>To manufacture for, and supply with coal gas, 15 burners for 4 hours per day, each burner giving a light equal to 10 ordinary candles.</i>                                                                                                                                                                                                                                                                                                                                                                                                                                 | <i>No. 2a Apparatus</i><br><i>To manufacture for, and supply with coal gas, 25 burners for 4 hours per day, each burner giving a light equal to 10 ordinary candles.</i>                                                                                                                                                                                                                                                                                                                                                                                                                               |
|-------------------------------------------------------------------------------------------------------------------------------------------------------|---------------------------------------------------------------------------------------------------------------------------------------------------------------------------------------------------------------------------------------------------------------------------------------------------------------------------------------------------------------------------------------------------------------------------------------------------------------------------------------------------------------------------------------------------------------------------|----------------------------------------------------------------------------------------------------------------------------------------------------------------------------------------------------------------------------------------------------------------------------------------------------------------------------------------------------------------------------------------------------------------------------------------------------------------------------------------------------------------------------------------------------------------------------------------------------------|--------------------------------------------------------------------------------------------------------------------------------------------------------------------------------------------------------------------------------------------------------------------------------------------------------------------------------------------------------------------------------------------------------------------------------------------------------------------------------------------------------------------------------------------------------------------------------------------------------|
| GENERATOR                                                                                                                                             | 1 PATENT VERTICAL GENERATING APPARATUS, consisting of:— 1 Retort capable of producing 22 cubic ft. of gas per charge from ordinary coal; 1 iron casing for ditto, fitted with 2 furnace doors and frames, 1 top plate, with plugs or covers for charging, and hopper, 1 bottom frame of cast iron, with bolts, plates, and nuts; 2 discharging doors, fitted with diaphragms, 1 wrought iron lever and wedge, 6 furnace grates; 1 smoke pipe elbow fitted with damper and cleaning plug; 1 nozzle for smoke pipe. 1 set of fire lumps, for lining the interior of casing. | 1 PATENT VERTICAL GENERATING APPARATUS, consisting of:— 1 Retort capable of producing 40 cubic ft. of gas per charge from ordinary coal; 1 iron casing for ditto, fitted with 2 furnace doors and frames, 1 top plate, with plugs or covers for charging, and hopper, 1 bottom plate of cast iron, with bolts, plates, and nuts; 2 discharging doors, fitted with diaphragms, 1 wrought iron lever and wedge, 6 furnace grates; 1 smoke pipe elbow fitted with damper and cleaning plug; 1 nozzle for smoke pipe; 1 set of fire lumps, for lining the interior of casing.                                | 1 PATENT VERTICAL GENERATING APPARATUS, consisting of:— 1 Retort capable of producing 72 cubic ft. of gas per charge from ordinary coal; 1 iron casing for ditto, fitted with 2 furnace doors and frames, 1 top plate, with plugs or covers for charging, and hopper, 1 bottom frame of cast iron, with bolts, plates and nuts; 2 discharging doors fitted with diaphragms, 1 wrought iron lever and wedge, 6 furnace grates; 1 smoke pipe elbow, fitted with damper and cleaning plug; 1 nozzle for smoke pipe; 1 set of fire lumps, for lining the interior of casing.                               |
| PURIFIER                                                                                                                                              | 1 PATENT COMBINED APPARATUS, forming in one vessel an Air Condenser and Purifier, fitted with sieves, cast iron cover and ground air plug, 2 syphon pipes, and 1 syphon box.                                                                                                                                                                                                                                                                                                                                                                                              | 1 PATENT COMBINED APPARATUS, forming in one vessel an Air Condenser and Purifier; fitted with sieves, wrought iron cover and ground air plug, 2 syphon pipes, and 1 syphon box.                                                                                                                                                                                                                                                                                                                                                                                                                          | 1 PATENT COMBINED APPARATUS, forming in one vessel an Air Condenser and Purifier; fitted with sieves, wrought iron cover and ground air plug, 2 syphon pipes and 1 syphon box.                                                                                                                                                                                                                                                                                                                                                                                                                         |
| GASHOLDER                                                                                                                                             | 1 GASHOLDER, 5 ft. diameter X 2 ft. 6 in. deep at the sides, containing 50 cubic ft. of gas; the crown and sides to be of No. 18 Birmingham wire gauge thickness, with suitable internal framework. 1 wrought iron Tank for Gas-holder, 5 ft. 4 in. diameter X 2 ft. 8 in. deep; the bottom and sides to be of No. 18 Birmingham wire gauge thickness, with iron framing; 1 central guide column of wrought iron, secured to bottom of tank.                                                                                                                              | 1 GASHOLDER, 6 ft. diameter X 4 ft. deep, at the sides, containing 120 cubic ft. of gas; the crown and sides to be of No. 18 Birmingham wire gauge thickness, with suitable internal framework. 2 cast iron Guide Columns, each 5 ft. high; 1 pair of wrought iron girders to connect the tops of columns; 6 foundation bolts and 2 foundation plates; 1 set of chain slings, 2 chain pulleys, axles and balance weights; 2 guide rollers, with carriages, adjusting plates, axles, and bolts for top of sides, and 4 guide rollers, with carriages, axles, and bolts, for bottom of sides of Gasholder. | 1 GASHOLDER, 6 ft. diameter X 6 feet deep at the sides, containing 180 cubic feet of gas; the crown and sides to be of No. 18 Birmingham wire gauge thickness, with suitable internal framework. 2 cast iron Guide Columns, each 7 ft. high; 1 pair of wrought iron girders to connect the tops of columns; 6 foundation bolts and 2 foundation plates; 1 set of chain slings, 2 chain pulleys, axles and balance weights; 2 guide rollers, with carriages, adjusting plates, axles and bolts for top of sides, and 4 guide rollers, with carriages, axles and bolts for bottom of sides of Gasholder. |
| CONNECTIONS, ETC.                                                                                                                                     | All necessary connecting pipes of 1½-in. bore, not exceeding 30 ft. from the Generating Apparatus to the outlet valve of Gasholder, 2 1½-in. cocks for inlet and outlet of Gas-holder, 2 syphon boxes; 2 ¾-in. wrought iron suction pipes, 1 brass syphon pump, 1 set of stoking tools. All bolts, pins, rivets, cement, lead, yarn, red and white lead, paint and oil requisite to fix the above, and to give the whole one coat of metallic oxide paint after completion.                                                                                               | All necessary 2 in. connecting pipes, not exceeding 40 ft. from the Generator into and out of Gasholder to outlet valve; 2 2-in. rising plug valves for inlet and outlet of Gasholder; 2 2-in. tank syphon boxes, 2 ¾-in. wrought iron suction pipes, 1 brass syphon pump, 1 set of stoking tools. All bolts, pins, rivets, cement, lead, yarn, red and white lead, paint and oil required to fix the above, and to give the whole one coat of metallic oxide paint after completion.                                                                                                                    | All necessary 2-in. connecting pipes not exceeding 40 ft. from the Generator into and out of Gasholder to outlet valve; 2 2-in. Rising Plug Valves for inlet and outlet of Gasholder; 2 2-in. tank syphon boxes, 2 ¾-in. wrought iron suction pipes, 1 brass syphon pump, 1 set of stoking tools. All bolts, pins, rivets, cement, lead, yarn, red and white lead, paint and oil required to fix the above, and to give the whole one coat of metallic oxide paint after completion.                                                                                                                   |
| Total dead weight of ironwork, etc.                                                                                                                   | 15 cwts.                                                                                                                                                                                                                                                                                                                                                                                                                                                                                                                                                                  | 35 cwts.                                                                                                                                                                                                                                                                                                                                                                                                                                                                                                                                                                                                 | 40 cwts.                                                                                                                                                                                                                                                                                                                                                                                                                                                                                                                                                                                               |
| Measurement in cubic ft., additional                                                                                                                  | ..                                                                                                                                                                                                                                                                                                                                                                                                                                                                                                                                                                        | 45                                                                                                                                                                                                                                                                                                                                                                                                                                                                                                                                                                                                       | 90                                                                                                                                                                                                                                                                                                                                                                                                                                                                                                                                                                                                     |
| Export Price, delivered at the Docks in Liverpool, London, or Hull, inclusive of packing and cases                                                    |                                                                                                                                                                                                                                                                                                                                                                                                                                                                                                                                                                           |                                                                                                                                                                                                                                                                                                                                                                                                                                                                                                                                                                                                          |                                                                                                                                                                                                                                                                                                                                                                                                                                                                                                                                                                                                        |
| Home Price, delivered at St. Neots Station, erected complete in England, exclusive of buildings, foundations, brickwork or wood work, or scaffolding. |                                                                                                                                                                                                                                                                                                                                                                                                                                                                                                                                                                           |                                                                                                                                                                                                                                                                                                                                                                                                                                                                                                                                                                                                          |                                                                                                                                                                                                                                                                                                                                                                                                                                                                                                                                                                                                        |
| Approximate cost of suitable buildings                                                                                                                |                                                                                                                                                                                                                                                                                                                                                                                                                                                                                                                                                                           |                                                                                                                                                                                                                                                                                                                                                                                                                                                                                                                                                                                                          |                                                                                                                                                                                                                                                                                                                                                                                                                                                                                                                                                                                                        |

SPECIFICATIONS OF APPARATUS FOR THE MANUFACTURE OF COAL GAS,

CAPABLE OF PRODUCING, FROM THREE CHARGES OF THE RETORTS, SUFFICIENT GAS TO SUPPLY THE NUMBER OF BURNERS FOR THE TIME STATED.

|                                                                                                                                                     | <i>No. 3a Apparatus</i><br><i>To manufacture for, and supply with coal gas, 40 burners for 4 hours per day, each burner giving a light equal to 10 ordinary candles.</i>                                                                                                                                                                                                                                                                                                                                                                                                                                       | <i>No. 4a Apparatus</i><br><i>To manufacture for, and supply with coal gas, 50 burners for 4 hours per day, each burner giving a light equal to 10 ordinary candles.</i>                                                                                                                                                                                                                                                                                                                                                                                                                                               |
|-----------------------------------------------------------------------------------------------------------------------------------------------------|----------------------------------------------------------------------------------------------------------------------------------------------------------------------------------------------------------------------------------------------------------------------------------------------------------------------------------------------------------------------------------------------------------------------------------------------------------------------------------------------------------------------------------------------------------------------------------------------------------------|------------------------------------------------------------------------------------------------------------------------------------------------------------------------------------------------------------------------------------------------------------------------------------------------------------------------------------------------------------------------------------------------------------------------------------------------------------------------------------------------------------------------------------------------------------------------------------------------------------------------|
| GENERATOR                                                                                                                                           | 1 PATENT VERTICAL GENERATING APPARATUS, consisting of 1 Retort capable of producing 135 cubic ft. of gas per charge from ordinary coal; 1 iron casing for ditto, fitted with two furnace doors and frames, 1 top plate, with plugs or covers for charging, and hopper, 1 bottom frame of cast iron, with bolts, plates and nuts; 2 discharging doors, fitted with diaphragms, 1 wrought iron lever and wedge, 6 furnace grates; 1 smoke pipe elbow, fitted with damper and cleaning plug; 1 nozzle for smoke pipe; one set of fire lumps, for lining the interior of casing.                                   | 1 PATENT VERTICAL GENERATING APPARATUS, consisting of 1 Retort capable of producing 150 cubic feet of gas per charge from ordinary coal; 1 iron casing for ditto, fitted with 2 furnace doors and frames, 1 top plate, with plugs or covers for charging, and hopper, 1 bottom frame of cast iron, with bolts, plates and nuts; 2 discharging doors, fitted with diaphragm, 1 wrought iron lever and wedge, 6 furnace grates; 1 smoke pipe elbow, fitted with damper and cleaning plug; one nozzle for smoke pipe; 1 set of fire lumps, for lining the interior of casing.                                             |
| PURIFIER                                                                                                                                            | 1 PATENT COMBINED APPARATUS, forming in one vessel an Air Condenser and Purifier; fitted with sieves, wrought iron cover and ground air plug, 2 syphon pipes and 1 syphon box.                                                                                                                                                                                                                                                                                                                                                                                                                                 | 1 PATENT COMBINED APPARATUS, forming in one vessel an Air Condenser and Purifier; fitted with sieves, wrought iron cover and ground air plug, 2 syphon pipes and 1 syphon box.                                                                                                                                                                                                                                                                                                                                                                                                                                         |
| GASHOLDER                                                                                                                                           | 1 GASHOLDER, 8 ft. diameter X 8 ft. deep at the sides, containing 400 cubic ft. of gas; the crown and sides to be of No. 18 Birmingham wire gauge thickness, with suitable internal framework. 2 cast iron Guide Columns, each 9 ft. high; 1 pair of wrought iron girders and bolts to connect the tops of columns; 6 foundation bolts and 2 foundation plates; 1 set of chain slings, 2 chain pulleys, axles and balance weights; 2 guide rollers, with carriages, adjusting plates, axles and bolts for top of sides, and 4 guide rollers, with carriages, axles and bolts for bottom of sides of Gasholder. | 1 GASHOLDER, 10 ft. diameter X 6 ft. deep at the sides, containing 470 cubic ft. of gas; the crown and sides to be of No. 16 Birmingham wire gauge thickness, with suitable internal framework. 3 cast iron Guide Columns, each 7 ft. high, 3 wrought iron girder bars and bolts to connect the tops of columns; 9 foundation bolts and 3 foundation plates; 3 sets of chain slings, pulleys, carriages, axles, balance weights and bolts, 3 guide rollers, with carriages, adjusting plates, axles and bolts for top of sides, and 6 guide rollers, with carriages, axles and bolts for bottom of sides of Gasholder. |
| CONNECTIONS, ETC.                                                                                                                                   | All necessary connecting pipes, not exceeding 60 ft. from the Generator into and out of Gasholder to outlet valve; 2 2-in. Rising Plug Valves for inlet and outlet of Gasholder; 2 2-in. tank syphon boxes, 2 2-in. wrought iron suction pipes, 1 brass syphon pump, 1 set of stoking tools. All bolts, pins, rivets, cement, lead, yarn, red and white lead, paint and oil required to fix the above, and to give the whole one coat of metallic oxide paint after completion.                                                                                                                                | All necessary connecting pipes, not exceeding 72 ft. from the Generator into and out of Gasholder to outlet valve; 2 2-in. Rising Plug Valves for inlet and outlet of Gasholder; 2 2-in. tank syphon boxes, 2 2-in. wrought iron suction pipes, 1 brass syphon pump, 1 set of stoking tools. All bolts, pins, rivets, cement, lead, yarn, red and white lead, paint and oil required to fix the above, and to give the whole one coat of metallic oxide paint after completion.                                                                                                                                        |
| Total dead weight of ironwork, etc.                                                                                                                 | 55 cwts.                                                                                                                                                                                                                                                                                                                                                                                                                                                                                                                                                                                                       | 60 cwts.                                                                                                                                                                                                                                                                                                                                                                                                                                                                                                                                                                                                               |
| Measurement in cubic ft. additional                                                                                                                 | 100                                                                                                                                                                                                                                                                                                                                                                                                                                                                                                                                                                                                            | 132                                                                                                                                                                                                                                                                                                                                                                                                                                                                                                                                                                                                                    |
| Export Price, delivered at the Docks in Liverpool, London, or Hull, inclusive of packing and cases.                                                 |                                                                                                                                                                                                                                                                                                                                                                                                                                                                                                                                                                                                                |                                                                                                                                                                                                                                                                                                                                                                                                                                                                                                                                                                                                                        |
| Home Price, delivered at St. Neots station, erected complete in England, exclusive of buildings, foundations, brickwork or woodwork, or scaffolding |                                                                                                                                                                                                                                                                                                                                                                                                                                                                                                                                                                                                                |                                                                                                                                                                                                                                                                                                                                                                                                                                                                                                                                                                                                                        |
| Weight of firebricks                                                                                                                                | 8½ cwts.                                                                                                                                                                                                                                                                                                                                                                                                                                                                                                                                                                                                       | 12 cwts.                                                                                                                                                                                                                                                                                                                                                                                                                                                                                                                                                                                                               |
| Approximate cost of buildings                                                                                                                       |                                                                                                                                                                                                                                                                                                                                                                                                                                                                                                                                                                                                                |                                                                                                                                                                                                                                                                                                                                                                                                                                                                                                                                                                                                                        |

The foregoing complete the list of Portable Apparatus, as illustrated in Section A, page 13.

## SPECIFICATIONS OF APPARATUS FOR THE MANUFACTURE OF COAL GAS FOR MANSIONS, RAILWAY STATIONS, &amp; FACTORIES.

CAPABLE OF PRODUCING, FROM THREE CHARGES OF THE RETORT, SUFFICIENT GAS TO SUPPLY THE NUMBER OF BURNERS FOR THE TIME STATED.

|                                                                                                                                                     | <i>No. 5a Apparatus</i><br>To manufacture for, and supply with gas, 60 burners for 4 hours per day, each burner consuming $3\frac{1}{2}$ cubic feet per hour.                                                                                                                                                                                                                                                                                                                                                                                                                                                                                                | <i>No. 6a Apparatus</i><br>To manufacture for, and supply with gas, 100 burners for 4 hours per day, each burner consuming $3\frac{1}{2}$ cubic feet per hour.                                                                                                                                                                                                                                                                                                                                                                                                                                                                                                  |
|-----------------------------------------------------------------------------------------------------------------------------------------------------|--------------------------------------------------------------------------------------------------------------------------------------------------------------------------------------------------------------------------------------------------------------------------------------------------------------------------------------------------------------------------------------------------------------------------------------------------------------------------------------------------------------------------------------------------------------------------------------------------------------------------------------------------------------|-----------------------------------------------------------------------------------------------------------------------------------------------------------------------------------------------------------------------------------------------------------------------------------------------------------------------------------------------------------------------------------------------------------------------------------------------------------------------------------------------------------------------------------------------------------------------------------------------------------------------------------------------------------------|
| RETORT STACK                                                                                                                                        | One evaporating pan, 3 furnace bars, 1 dead plate, 1 bearing bar, 1 10-in. furnace door and frame, 2 shield tiles for furnace door, 3 sight boxes and covers, 8 pilasters, 4 tie bolts, 1 girder bar, 2 dwarf pilasters and 4 bolts, 1 damper tile, with wrought iron rod, 1 set of stoking tools. 1 cast iron $\square$ shaped Retort 4 feet long $\times$ 12 in. $\times$ 12 in. inside measures, 1 mouthpiece and 2 lids for ditto; 1 pair of wrought iron ears, 1 cross-bar, and 1 square-threaded T screw; 1 3-in. saddle flange pipe and bolts, 6 bolts for mouthpiece; 3-in. connecting pipe from Retort to Combined Apparatus.                       | One evaporating pan, 3 furnace bars, 1 dead plate, 1 bearing bar, 1 10-in. furnace door and frame, 2 shield tiles for furnace door, 3 sight boxes and covers, 8 pilasters, 4 tie bolts, 1 girder bar, 2 dwarf pilasters and 4 bolts, 1 damper tile, fitted with wrought iron rod, 1 set of stoking tools. 1 cast iron $\square$ shaped Retort 6 feet long $\times$ 14 in. $\times$ 12 in. deep, inside measures, 1 mouthpiece and 2 lids for ditto; 6 bolts for mouthpiece, 1 pair of wrought iron ears, 1 cross-bar, and 1 square-threaded T screw; 1 3-in. saddle flange pipe and bolts, 8 yards of 3-in. connecting pipe, from Retort to Combined Apparatus. |
| PURIFIER                                                                                                                                            | ONE PATENT COMBINED APPARATUS, forming in one vessel an air condenser and purifier, fitted with sieves, wrought iron cover, 2 syphon pipes and 1 syphon box.                                                                                                                                                                                                                                                                                                                                                                                                                                                                                                 | ONE PATENT COMBINED APPARATUS, forming in one vessel an air condenser and purifier, fitted with wood sieves, wrought iron cover, 2 syphon pipes and 1 syphon box.                                                                                                                                                                                                                                                                                                                                                                                                                                                                                               |
| GASHOLDER                                                                                                                                           | One GASHOLDER 12 feet diameter $\times$ 8 feet deep at the sides, containing 900 cubic feet of gas; the sheets forming the crown and sides to be of No. 16 Birmingham wire gauge thickness, with strong and suitable internal framework. 3 cast iron Guide columns each 9 feet high; 3 wrought iron girders and bolts to connect the tops of columns; 9 foundation bolts and 3 foundation plates; 3 sets of chain slings, pulleys, carriages, axles, balance weights, and bolts; 3 guide pulleys with carriages, adjusting plates, axles, and bolts for top of sides, and 6 guide rollers with carriages, axles, and bolts for bottom of sides of Gasholder. | One GASHOLDER 14 feet diameter $\times$ 8 feet deep at the sides, containing 1250 cubic feet of gas; the sheets forming the crown and sides to be of No. 16 Birmingham wire gauge thickness, with strong and suitable internal framework. 3 cast Guide columns each 9 feet high; 3 wrought iron girders and bolts to connect the tops of columns; 9 foundation bolts and 3 foundation plates; 3 sets of chain slings, pulleys, carriages, axles, balance weights, and bolts; 3 guide pulleys with carriages, adjusting plates, axles, and bolts for top of sides, and 6 guide rollers with carriages, axles, and bolts for bottom of sides of Gasholder.        |
| CONNECTIONS, ETC.                                                                                                                                   | All necessary 2-in. connecting pipes, not exceeding 60 feet, from the Combined Apparatus into and out of Gasholder to outlet valve; 2 2-in. valves for inlet and outlet of Gasholder; 2 2-in. tank syphon boxes, 2 $\frac{3}{4}$ -in. wrought iron suction pipes, 1 brass syphon pump; all bolts, pins, rivets, cement, lead, yarn, red and white lead, paint and oil requisite to fix the above, and to give the whole one coat of metallic oxide paint after completion.                                                                                                                                                                                   | All necessary 2-in. connecting pipes, not exceeding 60 feet, from the Combined Apparatus into and out of Gasholder to outlet valve; 2 2-in. valves fitted for inlet and outlet of Gasholder; 2 2-in. tank syphon boxes, 2 $\frac{3}{4}$ -in. wrought iron suction pipes, 1 brass syphon pump, all bolts, pins, rivets, cement, lead, yarn, red and white lead, paint and oil requisite to fix the same, and to give the whole one coat of metallic oxide paint after completion.                                                                                                                                                                                |
| Total dead weight of ironwork, etc.                                                                                                                 | 5 tons.                                                                                                                                                                                                                                                                                                                                                                                                                                                                                                                                                                                                                                                      | 5 tons 10 cwt.                                                                                                                                                                                                                                                                                                                                                                                                                                                                                                                                                                                                                                                  |
| Export Price delivered at the Docks in London, Liverpool, or Hull, inclusive of packing and Cases.                                                  |                                                                                                                                                                                                                                                                                                                                                                                                                                                                                                                                                                                                                                                              |                                                                                                                                                                                                                                                                                                                                                                                                                                                                                                                                                                                                                                                                 |
| Home Price delivered at St. Neots Station, and erected complete in England, exclusive of buildings, foundations, brick or woodwork, or scaffolding. |                                                                                                                                                                                                                                                                                                                                                                                                                                                                                                                                                                                                                                                              |                                                                                                                                                                                                                                                                                                                                                                                                                                                                                                                                                                                                                                                                 |
| Quantity of Firebricks, &c., required to set retort.                                                                                                | 350 square and 200 arch bricks; 15 split bricks, 4 tiles 12 in. $\times$ 9 in. $\times$ 2 $\frac{1}{2}$ in. and 6 cwt. of fireclay.                                                                                                                                                                                                                                                                                                                                                                                                                                                                                                                          | 550 square and 300 arch bricks; 20 split bricks, 6 tiles 12 in. $\times$ 9 in. $\times$ 2 $\frac{1}{2}$ in. and 8 cwt. of fireclay.                                                                                                                                                                                                                                                                                                                                                                                                                                                                                                                             |
| Weight of firebricks, &c.                                                                                                                           | 2 tons 2 cwt.                                                                                                                                                                                                                                                                                                                                                                                                                                                                                                                                                                                                                                                | 3 tons 10 cwt.                                                                                                                                                                                                                                                                                                                                                                                                                                                                                                                                                                                                                                                  |
| Price of firebricks, &c., delivered at the Docks in London, Liverpool, or Hull.                                                                     |                                                                                                                                                                                                                                                                                                                                                                                                                                                                                                                                                                                                                                                              |                                                                                                                                                                                                                                                                                                                                                                                                                                                                                                                                                                                                                                                                 |
| Approximate cost of suitable buildings.                                                                                                             |                                                                                                                                                                                                                                                                                                                                                                                                                                                                                                                                                                                                                                                              |                                                                                                                                                                                                                                                                                                                                                                                                                                                                                                                                                                                                                                                                 |



SPECIFICATIONS OF APPARATUS FOR THE MANUFACTURE OF COAL GAS—continued.

|                                                                                                                                                                                                                                                                                                                                               | No. 7a Apparatus<br><i>To manufacture for, and supply with coal gas, 200 burners for 4 hours, or 100 burners for 8 hours, per day, each burner consuming 3½ cubic feet per hour.</i>                                                                                                                                                                                                                                                                                                                                                                                                                                                                                                                                                                                                                                                                                                                                                                | No. 8a Apparatus.<br><i>To manufacture for, and supply with coal gas, 300 burners for 4 hours, or 150 burners for 8 hours per day, each burner consuming 3½ cubic feet per hour.</i>                                                                                                                                                                                                                                                                                                                                                                                                                                                                                                                                                                                                                                                                                                           |
|-----------------------------------------------------------------------------------------------------------------------------------------------------------------------------------------------------------------------------------------------------------------------------------------------------------------------------------------------|-----------------------------------------------------------------------------------------------------------------------------------------------------------------------------------------------------------------------------------------------------------------------------------------------------------------------------------------------------------------------------------------------------------------------------------------------------------------------------------------------------------------------------------------------------------------------------------------------------------------------------------------------------------------------------------------------------------------------------------------------------------------------------------------------------------------------------------------------------------------------------------------------------------------------------------------------------|------------------------------------------------------------------------------------------------------------------------------------------------------------------------------------------------------------------------------------------------------------------------------------------------------------------------------------------------------------------------------------------------------------------------------------------------------------------------------------------------------------------------------------------------------------------------------------------------------------------------------------------------------------------------------------------------------------------------------------------------------------------------------------------------------------------------------------------------------------------------------------------------|
| RETORT STACK.                                                                                                                                                                                                                                                                                                                                 | One evaporating pan, 3 furnace bars, 1 dead plate, 1 bearing bar, 1 10-in. furnace door and frame, 2 shield tiles for furnace door, 6 sight boxes and covers, 8 pilasters, 4 tie rods, 1 girder bar, 2 dwarf pilasters and 4 bolts, 1 damper tile, fitted with wrought iron rod, 1 set of stoking tools, 2 cast iron $\square$ shaped Retorts each 6 feet long $\times$ 14-in. wide $\times$ 12 in. deep inside measures, 2 mouthpieces and 4 lids for ditto, 12 ¾-in. bolts for mouthpieces, 2 pairs of wrought iron ears, 2 cross bars, and 2 square-threaded T screws; 2' 3-in. saddle flange pipes and bolts; 2 3-in. ascension pipes; 2 3-in. N pipes with cleaning plugs, 2 3-in. dip pipes and bolts; 1 10-in. Hydraulic Main of sufficient length to receive the dip pipes from both Retorts with ends and bolts; 2 crutched pillars to support Hydraulic Main; 30 feet of 3 in. connecting pipe from Hydraulic Main to Combined Apparatus. | Two evaporating pans, 6 furnace bars, 2 bearing bars, 2 dead plates, 2 10-in. furnace doors and frames, 4 shield tiles for furnace doors, 10 sight boxes and covers, 10 pilasters, 5 tie bolts, 2 girder bars, 4 dwarf pilasters and 8 bolts, 2 damper tiles, fitted with wrought iron rods, 1 set of stoking tools, 3 cast iron $\square$ shaped Retorts, each 7 ft. long $\times$ 14 in. wide $\times$ by 12 in. deep inside measures, 3 mouthpieces and 6 covers for ditto; 18 ¾-in. bolts for mouthpieces; 3 pairs of wrought iron ears, 3 cross-bars, and 3 square-threaded T screws; 3 4-in. saddle flange pipes and bolts; 3 4-in. ascension pipes; 3 4-in. dip pipes and bolts; 3 4-in. N pipes with cleaning plugs, 1 10-in. Hydraulic Main of sufficient length to receive the dip pipes from all the Retorts with ends and bolts; 3 crutched pillars to support the Hydraulic Main. |
| CONDENSER.                                                                                                                                                                                                                                                                                                                                    |                                                                                                                                                                                                                                                                                                                                                                                                                                                                                                                                                                                                                                                                                                                                                                                                                                                                                                                                                     | One AIR CONDENSER, consisting of one bottom box, consisting of 8 3-in. pipes each 9 feet long, 4 3-in. arch pipes, with 2 cleaning plugs to each, 2 dip cisterns, 14 in. $\times$ 14 in. $\times$ 21 in. deep, 2 3-in. T pipes and bolts for inlet and outlet.                                                                                                                                                                                                                                                                                                                                                                                                                                                                                                                                                                                                                                 |
| PURIFIER.                                                                                                                                                                                                                                                                                                                                     | One PATENT COMBINED APPARATUS, forming in one vessel an air condenser and purifier, fitted with wood sieves, wrought iron cover, 2 syphon pipes and 1 syphon box.                                                                                                                                                                                                                                                                                                                                                                                                                                                                                                                                                                                                                                                                                                                                                                                   | Two dry lime PURIFIERS, each 5 ft. $\times$ 2 ft. 3 in. $\times$ 2 ft. 6 in. deep, fitted with 4 tiers of sieves or grids, water lutes, and wrought iron covers; 1 lifting carriage and chain slings for removing and replacing covers, 2 3-in. fourway rising plug valves, for changing the direction of the current of gas in Purifiers.                                                                                                                                                                                                                                                                                                                                                                                                                                                                                                                                                     |
| GASHOLDER.                                                                                                                                                                                                                                                                                                                                    | One GASHOLDER 18 feet diameter and 10 feet deep at the sides, containing 2600 cubic feet of gas; the sheets forming the crown and sides to be of No. 16 Birmingham wire gauge thickness, with strong and suitable internal frame work; 3 cast-iron Guide columns each 11 feet high; 3 wrought iron girders and bolts to connect the tops of columns; 9 foundation bolts and 3 foundation plates; 3 sets of chain slings, pulleys, carriages, axles, balance weights, and bolts; 3 guide pulleys with carriages, adjusting plates, axles, and bolts for top of sides, and 6 guide rollers with carriages, axles, and bolts for bottom of sides of Gasholder.                                                                                                                                                                                                                                                                                         | One GASHOLDER 22 feet diameter $\times$ 10 feet deep at the sides, containing 3,800 cubic feet of gas; the sheets forming the crown and sides to be of No. 16 Birmingham wire gauge thickness, with strong and suitable internal framework. 3 cast iron Guide columns each 11 feet high; 3 wrought iron girders and bolts to connect the tops of columns; 9 foundation bolts and 3 foundation plates; 3 sets of chain slings, pulleys, carriages, axles, balance weights, and bolts; 3 guide pulleys with carriages, adjusting plates, axles, and bolts for top of sides, and 6 guide rollers with carriages, axles, and bolts for bottom of sides of Gasholder.                                                                                                                                                                                                                               |
| CONNECTIONS AND SUNDRIES.                                                                                                                                                                                                                                                                                                                     | All the necessary 3-in. connecting pipes, not exceeding 70 feet, from the Combined Apparatus into and out of gasholder to outlet valve; 2 3-in. valves fitted for inlet and outlet of Gasholder; 2 3-in. tank syphon boxes, 2 ¾-in. wrought iron suction pipes, 1 brass syphon pump; all bolts, pins, rivets, cement, lead, yarn, red and white lead, paint and oil requisite to fix the above, and to give the whole one coat of metallic oxide paint after completion.                                                                                                                                                                                                                                                                                                                                                                                                                                                                            | All the necessary 3-in. connecting pipes, not exceeding 150 feet, from the Hydraulic Main to condenser, purifiers, into and out of Gasholder to outlet valve; 2 3-in. valves for inlet and outlet of Gasholder; 2 3-in. tank syphon boxes, 2 ¾-in. wrought iron suction pipes, 1 brass syphon pump; all bolts, pins, rivets, cement, lead, yarn, red and white lead, paint and oil, requisite to fix the above, and to give the whole one coat of metallic oxide paint after completion.                                                                                                                                                                                                                                                                                                                                                                                                       |
| Total dead weight of ironwork, etc. Export Price delivered at the Docks in London, Liverpool, or Hull, inclusive of packing and Cases. Home Price delivered at St. Neots Station and erected complete in England, exclusive of buildings, foundations, brick or woodwork, or scaffolding. Quantity of Firebricks, &c. required to set retort. | 8 tons 10 cwt.                                                                                                                                                                                                                                                                                                                                                                                                                                                                                                                                                                                                                                                                                                                                                                                                                                                                                                                                      | 11 tons 10 cwt.                                                                                                                                                                                                                                                                                                                                                                                                                                                                                                                                                                                                                                                                                                                                                                                                                                                                                |
| Weight of Firebricks, &c. Price of Firebricks, &c., delivered at the Docks in London, Liverpool, or Hull. Approximate cost of suitable buildings.                                                                                                                                                                                             | 3 tons 15 cwt.                                                                                                                                                                                                                                                                                                                                                                                                                                                                                                                                                                                                                                                                                                                                                                                                                                                                                                                                      | 7 tons 11 cwt.                                                                                                                                                                                                                                                                                                                                                                                                                                                                                                                                                                                                                                                                                                                                                                                                                                                                                 |
|                                                                                                                                                                                                                                                                                                                                               | 700 square and 300 arch bricks 24 tiles 12 in. $\times$ 9 in. $\times$ 2½ in. and 5 tiles 21 in. $\times$ 15 in. $\times$ 3 in., 9 cwt. of fireclay.                                                                                                                                                                                                                                                                                                                                                                                                                                                                                                                                                                                                                                                                                                                                                                                                | 1,400 square and 700 arch bricks; 20 split bricks; 30 tiles 12 in. $\times$ 9 in. $\times$ 2 in.; 7 tiles 12 in. $\times$ 9 in. $\times$ 2½ in.; 5 tiles 21 in. $\times$ 15 in. $\times$ 3 in. and 1 ton of fireclay.                                                                                                                                                                                                                                                                                                                                                                                                                                                                                                                                                                                                                                                                          |

SPECIFICATIONS OF APPARATUS FOR THE MANUFACTURE OF COAL GAS—continued.

|                                                                                                                                                           | <i>No. 9a Apparatus.</i><br><i>To manufacture for, and supply with coal gas, 400 burners for 4 hours, or 200 burners for 8 hours for day, each burner consuming 3½ cubic feet per hour.</i>                                                                                                                                                                                                                                                                                                                                                                                                                                                                                                                                                                                                                                                                                                                | <i>No. 10a Apparatus</i><br><i>To manufacture for, and supply with coal gas, 500 burners for 4 hours, or 250 burners for 8 hours per day, each burner consuming 3½ cubic feet per hour.</i>                                                                                                                                                                                                                                                                                                                                                                                                                                                                                                                                                                                                                                                                                                             |
|-----------------------------------------------------------------------------------------------------------------------------------------------------------|------------------------------------------------------------------------------------------------------------------------------------------------------------------------------------------------------------------------------------------------------------------------------------------------------------------------------------------------------------------------------------------------------------------------------------------------------------------------------------------------------------------------------------------------------------------------------------------------------------------------------------------------------------------------------------------------------------------------------------------------------------------------------------------------------------------------------------------------------------------------------------------------------------|---------------------------------------------------------------------------------------------------------------------------------------------------------------------------------------------------------------------------------------------------------------------------------------------------------------------------------------------------------------------------------------------------------------------------------------------------------------------------------------------------------------------------------------------------------------------------------------------------------------------------------------------------------------------------------------------------------------------------------------------------------------------------------------------------------------------------------------------------------------------------------------------------------|
| <b>RETORT STACK.</b>                                                                                                                                      | Two evaporating pans, 6 furnace bars, 2 bearing bars, 2 dead plates, 2 10-in. furnace doors and frames, 4 shield tiles for furnace doors, 10 sight boxes and covers, 10 pilasters, 5 tie bolts, 2 girder bars, 4 dwarf pilasters and 8 bolts, 2 damper tiles, with wrought iron rods, 1 set of stoking tools, 4 cast iron $\square$ shaped Retorts each 7 ft. long $\times$ 14 in. wide $\times$ 12 in. deep inside measures, 4 mouthpieces and 8 covers for ditto; 24 $\frac{1}{2}$ -in. bolts for mouthpieces; 4 pairs of wrought iron ears, 4 cross-bars, and 4 square-threaded T screws; 4 4-in. saddle flange pipes and bolts; 4 4-in. ascension pipes; 4 4-in. N pipes with cleaning plugs, 4 4-in. dip pipes and bolts; 1 Hydraulic Main 12 in. diameter, and of sufficient length to receive the dip pipes from all the Retorts with ends and bolts; 3 cratched pillars to support Hydraulic Main. | Two evaporating pans, 6 furnace bars, 2 dead plates, 2 bearing bars, 2 10-in. furnace doors and frames, 4 shield tiles for furnace doors, 12 sight boxes and covers, 10 pilasters, 5 tie bolts, 2 girder bars, 4 dwarf pilasters and 8 bolts, 2 damper tiles with wrought iron rods, 1 set of stoking tools, 5 cast iron $\square$ shaped Retorts, each 7 ft. long $\times$ 14 in. wide $\times$ 12 ft. deep inside measures, 5 mouthpieces and 10 covers for ditto; 30 $\frac{1}{2}$ -in. bolts for mouthpieces; 5 pairs of wrought iron ears, 5 cross-bars, 5 square-threaded T screws; 5 4-in. saddle flange pipes and bolts; 5 4-in. ascension pipes; 5 4-in. N pipes with cleaning plugs, 5 4-in. dip pipes and bolts; 1 Hydraulic Main 12 in. diameter, and of sufficient length to receive the dip pipes from all the Retorts with ends and bolts; 3 cratched pillars to support Hydraulic Main. |
| <b>CONDENSER.</b>                                                                                                                                         | One AIR CONDENSER, consisting of 1 bottom box, 12 3-in. pipes each 9 ft. long, 6 3-in. arch pipes with 2 cleaning plugs to each, 2 dip cisterns, 14 in. $\times$ 14 in. $\times$ 21 in. deep, 2 3-in. T pipes and bolts for inlet and outlet.                                                                                                                                                                                                                                                                                                                                                                                                                                                                                                                                                                                                                                                              | One AIR CONDENSER, consisting of 1 bottom box, 10 4-in. pipes each 9 feet long, 5 4-in. arch pipes with 2 cleaning plugs to each, 2 dip cisterns 14 in. $\times$ 14 in. 21 in. deep, 2 3-in. T pipes and bolts for inlet and outlet.                                                                                                                                                                                                                                                                                                                                                                                                                                                                                                                                                                                                                                                                    |
| <b>PURIFIER.</b>                                                                                                                                          | Two dry lime PURIFIERS, each 5 ft. $\times$ 2 ft. 3 in. $\times$ 2 ft. 6 in. deep, fitted with 4 tiers of sieves or grids, water lutes, and wrought iron covers; 1 lifting carriage and chain slings for removing and replacing covers, 2 3-in. fourway rising plug valves, for changing the direction of the current of gas in Purifiers.                                                                                                                                                                                                                                                                                                                                                                                                                                                                                                                                                                 | Two dry lime PURIFIERS, each 6 ft. $\times$ 2 ft. 6 in. deep, fitted with 4 tiers of sieves or grids, water lutes, and wrought iron covers; 1 lifting carriage and chain slings for removing and replacing covers, 2 3-in. fourway rising plug valves, for changing the direction of the current of gas in Purifiers.                                                                                                                                                                                                                                                                                                                                                                                                                                                                                                                                                                                   |
| <b>GASHOLDER.</b>                                                                                                                                         | One GASHOLDER, 25 ft. diameter $\times$ 10 feet deep at the sides, containing 5,000 cubic feet of gas; the sheets forming the crown and sides to be of No. 16 Birmingham wire gauge thickness, with strong and suitable internal framework. 4 cast iron Guide columns, each 11 feet high; 4 wrought iron girders and bolts to connect the tops of columns; 12 foundation bolts and 4 foundation plates; 4 guide pulleys, with carriages, adjusting plates, axles, and bolts for top of sides, and 8 guide rollers with carriages, axles, and bolts for bottom of sides of Gasholder, 4 acorn knobs for tops of columns.                                                                                                                                                                                                                                                                                    | One GASHOLDER 30 ft. diameter $\times$ 10 ft. deep at the sides, containing 7000 cubic feet of gas; the sheets forming the crown and sides to be of No. 16 Birmingham wire gauge thickness, with strong and suitable internal framework. 4 cast iron guide columns, each 11 ft. high; 4 trussed wrought iron girders and bolts to connect the tops of columns; 12 foundation bolts and 4 foundation plates; 4 guide pulleys, with carriages, adjusting plates, axles, and bolts for top of sides, and 8 guide rollers with carriages, axles, and bolts for bottom of sides of Gasholder, 4 ornamental knobs for tops of columns.                                                                                                                                                                                                                                                                        |
| <b>CONNECTIONS AND SUNDRIES.</b>                                                                                                                          | All the necessary 3 in. connecting pipes, not exceeding 150 feet from the Hydraulic Main to condenser, purifiers, into and out of Gasholder to outlet valve; 2 3-in. valves for inlet and outlet of Gasholder; 2 3-in. tank syphon boxes, 2 $\frac{1}{2}$ -in. wrought iron suction pipes, 1 brass syphon pump. All bolts, pins, rivets, cement, lead, yarn, red and white lead, paint and oil, requisite to fix the above, and to give the whole one coat of metallic oxide paint after completion.                                                                                                                                                                                                                                                                                                                                                                                                       | All the necessary 3 in. connecting pipes, not exceeding 120 ft. from the Hydraulic Main to condenser, purifiers, into Gasholder, and 30 ft. of 4 in. to outlet valve from Gasholder; 2 3-in. valves for inlet and outlet of Gasholder; 1 3-in. and 1 4-in. tank syphon boxes, 2 $\frac{1}{2}$ -in. wrought iron suction pipes, 1 brass syphon pump. All bolts, pins, rivets, cement, lead, yarn, red and white lead, paint and oil, requisite to fix the above, and to give the whole one coat of metallic oxide paint after completion.                                                                                                                                                                                                                                                                                                                                                                |
| <b>Total dead weight of ironwork.</b>                                                                                                                     | 13 tons 15 cwt.                                                                                                                                                                                                                                                                                                                                                                                                                                                                                                                                                                                                                                                                                                                                                                                                                                                                                            | 16 tons.                                                                                                                                                                                                                                                                                                                                                                                                                                                                                                                                                                                                                                                                                                                                                                                                                                                                                                |
| <b>Measurement in cubic ft. additional.</b>                                                                                                               | 106                                                                                                                                                                                                                                                                                                                                                                                                                                                                                                                                                                                                                                                                                                                                                                                                                                                                                                        | 136                                                                                                                                                                                                                                                                                                                                                                                                                                                                                                                                                                                                                                                                                                                                                                                                                                                                                                     |
| <b>Export Price delivered at the Docks in London, Liverpool, or Hull, inclusive of packing and Cases.</b>                                                 |                                                                                                                                                                                                                                                                                                                                                                                                                                                                                                                                                                                                                                                                                                                                                                                                                                                                                                            |                                                                                                                                                                                                                                                                                                                                                                                                                                                                                                                                                                                                                                                                                                                                                                                                                                                                                                         |
| <b>Home Price delivered at St. Neots Station and erected complete in England, exclusive of buildings, foundations, brick or woodwork, or scaffolding.</b> |                                                                                                                                                                                                                                                                                                                                                                                                                                                                                                                                                                                                                                                                                                                                                                                                                                                                                                            |                                                                                                                                                                                                                                                                                                                                                                                                                                                                                                                                                                                                                                                                                                                                                                                                                                                                                                         |
| <b>Quantity of Firebricks, &amp;c. required to set Retorts.</b>                                                                                           | 18,00 square and 650 arch bricks; 100 split bricks; 5 T bricks 13 in. $\times$ 9 in.; 22 tiles 12 $\times$ 9 in. $\times$ 2½ in.; 18 tiles 19 in. $\times$ 15 in. $\times$ 3 in.; and 24 cwt. of fireclay.                                                                                                                                                                                                                                                                                                                                                                                                                                                                                                                                                                                                                                                                                                 | 2000 square and 650 arch bricks; 100 split bricks; 5 T bricks 13 in. $\times$ 9 in.; 45 tiles 12 in. $\times$ 9 in. $\times$ 2½ in.; 18 tiles 19 in. $\times$ 15 in. $\times$ 3 in.; 5 tiles 21 in. $\times$ 15 in. $\times$ 3 in., and 26 cwt. of fireclay.                                                                                                                                                                                                                                                                                                                                                                                                                                                                                                                                                                                                                                            |
| <b>Weight of Firebricks, &amp;c.</b>                                                                                                                      | 9 tons 6 cwt.                                                                                                                                                                                                                                                                                                                                                                                                                                                                                                                                                                                                                                                                                                                                                                                                                                                                                              | 11 tons 5 cwt.                                                                                                                                                                                                                                                                                                                                                                                                                                                                                                                                                                                                                                                                                                                                                                                                                                                                                          |
| <b>Price of Firebricks, &amp;c. delivered at the Docks in London, Liverpool, or Hull.</b>                                                                 |                                                                                                                                                                                                                                                                                                                                                                                                                                                                                                                                                                                                                                                                                                                                                                                                                                                                                                            |                                                                                                                                                                                                                                                                                                                                                                                                                                                                                                                                                                                                                                                                                                                                                                                                                                                                                                         |
| <b>Approximate cost of suitable buildings.</b>                                                                                                            |                                                                                                                                                                                                                                                                                                                                                                                                                                                                                                                                                                                                                                                                                                                                                                                                                                                                                                            |                                                                                                                                                                                                                                                                                                                                                                                                                                                                                                                                                                                                                                                                                                                                                                                                                                                                                                         |

SPECIFICATIONS OF APPARATUS FOR THE MANUFACTURE OF COAL GAS—continued.

|                                                                                              | <i>No. 11a Apparatus</i><br><i>To manufacture for, and supply with coal gas, 800 burners for 4 hours, or 400 burners for 8 hours per day, each burner consuming 3½ cubic feet per hour.</i>                                                                                                                                                                                                                                                                                                                                                                                                                                                                                                                                                                                                                                                                                                                | <i>No. 12a Apparatus.</i><br><i>To manufacture for, and supply with coal gas, 1200 burners for 4 hours, or 600 burners for 8 hours per day, each burner consuming 3½ cubic feet per hour.</i>                                                                                                                                                                                                                                                                                                                                                                                                                                                                                                                                                                                                                                                                                                                           |
|----------------------------------------------------------------------------------------------|------------------------------------------------------------------------------------------------------------------------------------------------------------------------------------------------------------------------------------------------------------------------------------------------------------------------------------------------------------------------------------------------------------------------------------------------------------------------------------------------------------------------------------------------------------------------------------------------------------------------------------------------------------------------------------------------------------------------------------------------------------------------------------------------------------------------------------------------------------------------------------------------------------|-------------------------------------------------------------------------------------------------------------------------------------------------------------------------------------------------------------------------------------------------------------------------------------------------------------------------------------------------------------------------------------------------------------------------------------------------------------------------------------------------------------------------------------------------------------------------------------------------------------------------------------------------------------------------------------------------------------------------------------------------------------------------------------------------------------------------------------------------------------------------------------------------------------------------|
| <b>RETORT STACK.</b>                                                                         | Three evaporating pans, 9 furnace bars, 3 dead plates, 3 bearing bars, 3 10-in. furnace doors and frames, 6 shield tiles for furnace doors, 17 sight boxes and covers, 12 pilasters, 6 tie bolts, 3 girder bars, 6 dwarf pilasters and 12 bolts, 3 damper tiles with wrought iron rods, 1 set of stoking tools. 7 cast iron $\square$ shaped Retorts, each 7 ft. long $\times$ 14 in. wide $\times$ 12 ft. deep inside measures, 7 mouthpieces and 14 covers for ditto; 42 $\frac{3}{4}$ -in. bolts for mouthpieces; 7 pairs of wrought iron ears, 7 cross-bars, 7 square-threaded T screws; 7 4-in. saddle flange pipes and bolts; 7 4-in. ascension pipes; 7 4-in. N pipes with cleaning plugs, 7 4-in. dip pipes and bolts; 1 Hydraulic Main 14 in. diameter, and of sufficient length to receive the dip pipes from all the Retorts with ends and bolts; 4 crutched pillars to support Hydraulic Main. | Three evaporating pans, 9 furnace bars, 3 dead plates, 3 bearing bars, 3 10-in. furnace doors and frames, 6 shield tiles for furnace doors, 26 sight boxes and covers, 12 pilasters, 6 tie bolts, 3 girder bars, 6 dwarf pilasters and 12 bolts, 3 damper tiles, with wrought iron rods, 1 set of stoking tools, 10 cast iron $\square$ shaped Retorts each 7 ft. long $\times$ 14 in. wide $\times$ 12 in. deep inside measures, 10 mouthpieces and 20 covers for ditto; 63 $\frac{3}{4}$ -in. bolts for mouthpieces; 10 pairs of wrought iron ears, 10 cross-bars, and 10 square-threaded T screws; 10 4-in. saddle flange pipes and bolts; 10 4-in. ascension pipes; 10 4-in. N pipes with cleaning plugs, 10 4-in. dip pipes and bolts; 1 Hydraulic Main 14 in. diameter, and of sufficient length to receive the dip pipes from all the Retorts with ends and bolts; 4 crutched pillars to support Hydraulic Main. |
| <b>CONDENSER.</b>                                                                            | One AIR CONDENSER, consisting of 1 bottom box, fitted with cleaning doors, 14 4-in. pipes each 9 feet long, 7 4-in. arch pipes with 2 cleaning plugs to each, 2 dip cisterns 14 in. $\times$ 14 in. $\times$ 21 in. deep, 2 4-in. T pipes and bolts for inlet and outlet.                                                                                                                                                                                                                                                                                                                                                                                                                                                                                                                                                                                                                                  | One AIR CONDENSER, consisting of 1 bottom box, fitted with cleaning doors, 12 5-in. pipes each 9 ft. long, 6 5-in. arch pipes with 2 cleaning plugs to each, 2 dip cisterns, 14 in. $\times$ 14 in. $\times$ 21 in. deep, 2 4-in. T pipes and bolts for inlet and outlet.                                                                                                                                                                                                                                                                                                                                                                                                                                                                                                                                                                                                                                               |
| <b>SCRUBBER.</b>                                                                             | One SCRUBBER 2 feet diameter $\times$ 9 feet high, fitted with 2 tiers of cast iron grids, 3 filling and discharging doors and frames, with cross-bars, T screws and bolts, 1 water spreader, with 1 in. main cock, key, and syphon pipe; 1 cap and 1 base plate; 2 4-in. dip cisterns 14 $\times$ 14-in. $\times$ 21 in. deep, 2 4-in. tees and bolts for inlet and outlet; 1 4-in. fourway rising plug valve for passing Scrubber.                                                                                                                                                                                                                                                                                                                                                                                                                                                                       | One SCRUBBER, 2 ft. diameter $\times$ 9 ft. high, fitted with 2 tiers of cast iron grids, 3 filling and discharging doors and frames, with cross-bars, T screws and bolts, 1 water spreader, with 1-in. main cock, key, and syphon pipe; 1 cap and 1 base plate; 2 4-in. dip cisterns 14 in. $\times$ by 14 in. $\times$ by 21 in. deep, 2 4-in. tees and bolts for inlet and outlet; 1 4-in. fourway rising plug valve for passing Scrubber.                                                                                                                                                                                                                                                                                                                                                                                                                                                                           |
| <b>PURIFIERS.</b>                                                                            | Two dry lime PURIFIERS, each 5 ft. $\times$ 4 ft. $\times$ 2 ft. 6 in. deep, fitted with 4 tiers of sieves or grids, T bearers, water lutes, and wrought iron covers: 1 lifting carriage and chain slings for removing and replacing covers, 2 4-in. fourway rising plug valves, for changing the direction of the current of gas in Purifiers.                                                                                                                                                                                                                                                                                                                                                                                                                                                                                                                                                            | Two dry lime PURIFIERS, each 8 ft. $\times$ 3 ft. 6 in. $\times$ 2 ft. 6 in. deep, fitted with 4 tiers of sieves or grids, T bearers, water lutes, and wrought iron covers; 1 lifting carriage and chain slings for removing and replacing covers, 2 4-in. fourway rising plug valves, for changing the direction of the current of gas in Purifiers.                                                                                                                                                                                                                                                                                                                                                                                                                                                                                                                                                                   |
| <b>GASHOLDER.</b>                                                                            | One GASHOLDER, 35 ft. diameter $\times$ 10 ft. deep at the sides, containing 9,600 cubic feet of gas; the sheets forming the crown and sides to be of No. 16 Birmingham wire gauge thickness, with strong and suitable internal framework. 5 cast iron guide columns, each 11 ft. high; 5 trussed wrought iron girders and bolts to connect the tops of columns; 15 foundation bolts and 5 foundation plates; 5 guide pulleys, with carriages, adjusting plates, axles, and bolts for top of sides, and 10 guide rollers with carriages, axles, and bolts for bottom of sides of Gasholder, 5 caps for tops of columns.                                                                                                                                                                                                                                                                                    | One GASHOLDER, 40 ft. diameter $\times$ 12 feet deep at the sides, containing 15,000 cubic feet of gas; the sheets forming the crown and sides to be of No. 16 Birmingham wire gauge thickness, excepting the top and bottom rows, which are to be of No. 14 B. w. g., with strong and suitable internal framework. 5 cast iron Guide columns, each 13 feet high; 5 trussed wrought iron girders and bolts to connect the tops of columns: 15 foundation bolts and 5 foundation plates; 5 guide pulleys, with carriages, adjusting plates, axles, and bolts for top of sides, and 10 guide rollers with carriages, axles, and bolts for bottom of sides of gasholder, 5 caps for tops of columns.                                                                                                                                                                                                                       |
| <b>CONNECTIONS AND SUN-DRIES.</b>                                                            | All the necessary 4 in. connecting pipes, not exceeding 75 yds. from the Hydraulic Main to condenser, scrubber, purifiers, into and out of Gasholder to outlet valve, for connecting the tar dip cisterns and from thence to tar well, 2 4-in. valves for inlet and outlet of Gasholder; 2 4-in. tank syphon boxes, 2 $\frac{3}{4}$ -in. wrought iron suction pipes, 1 brass syphon pump. All bolts, pins, rivets, cement, lead, yarn, red and white lead, paint and oil, requisite to fix the above, and to give the whole one coat of metallic oxide paint after completion.                                                                                                                                                                                                                                                                                                                             | All the necessary 4 in. connecting pipes, not exceeding 80 yards from the Hydraulic Main to condenser, scrubber, purifiers, into and out of Gasholder to outlet valve, with bends and T pieces for connecting the tar dip cisterns and from thence to tar well, 2 4-in. rising plug stop valves for inlet and outlet of gasholder; 2 4-in. tank syphon boxes, 2 $\frac{3}{4}$ -in. wrought iron suction pipes, 1 brass syphon pump. All bolts, pins, rivets, cement, lead, yarn, red and white lead, paint and oil, requisite to fix the above, and to give the whole one coat of metallic oxide paint after completion.                                                                                                                                                                                                                                                                                                |
| Total dead weight of Ironwork. Measurement additional.                                       | 23 tons 5 cwt.                                                                                                                                                                                                                                                                                                                                                                                                                                                                                                                                                                                                                                                                                                                                                                                                                                                                                             | 29 tons 10 cwt.                                                                                                                                                                                                                                                                                                                                                                                                                                                                                                                                                                                                                                                                                                                                                                                                                                                                                                         |
| Export Price, as per previous Specifications.                                                |                                                                                                                                                                                                                                                                                                                                                                                                                                                                                                                                                                                                                                                                                                                                                                                                                                                                                                            |                                                                                                                                                                                                                                                                                                                                                                                                                                                                                                                                                                                                                                                                                                                                                                                                                                                                                                                         |
| Home Price, as per previous Specifications.                                                  |                                                                                                                                                                                                                                                                                                                                                                                                                                                                                                                                                                                                                                                                                                                                                                                                                                                                                                            |                                                                                                                                                                                                                                                                                                                                                                                                                                                                                                                                                                                                                                                                                                                                                                                                                                                                                                                         |
| Quantity of Firebricks, etc., required to set Retorts.                                       | 3,000 square and 950 arch bricks; 200 split bricks; 10 T bricks 13 in. $\times$ 9 in.; 37 tiles 12 in. $\times$ 9 in. $\times$ 2½ in.; 36 tiles 19 in. $\times$ 15 in. $\times$ 3 in., and 2 tons of fireclay.                                                                                                                                                                                                                                                                                                                                                                                                                                                                                                                                                                                                                                                                                             | 3,800 square and 1,000 arch bricks; 100 split bricks; 8 pairs of flue lumps, 8 lumps 11 in. $\times$ 6 in. $\times$ 7 in. $\times$ 5 in. thick, 5 T bricks 13 in. $\times$ 9 in.; 10 rebated tiles 22 in. $\times$ 15 in. $\times$ 3 in.; 5 ditto 21 in. $\times$ 15 in. $\times$ 3 in.; 18 ditto 19 in. $\times$ 15 in. $\times$ 3 in.; 9 ditto 18 in. $\times$ 12 in. $\times$ 3 in.; 7 ditto 17 in. $\times$ 12 in. $\times$ 3 in.; 14 ditto 17 in. $\times$ 12 in. $\times$ 2½ in.; 15 ditto 12 in. $\times$ 9 in. $\times$ 2½ in.; 30 ditto 12 in. $\times$ 9 in. $\times$ 2 in.; and 46 cwt. of fireclay.                                                                                                                                                                                                                                                                                                         |
| Weight of Firebricks, etc. Price of Firebricks, etc. Approximate cost of suitable buildings. | 15 tons 10 cwt.                                                                                                                                                                                                                                                                                                                                                                                                                                                                                                                                                                                                                                                                                                                                                                                                                                                                                            | 19 tons 10 cwt.                                                                                                                                                                                                                                                                                                                                                                                                                                                                                                                                                                                                                                                                                                                                                                                                                                                                                                         |

## SPECIFICATIONS OF APPARATUS FOR THE MANUFACTURE OF COAL GAS—continued.

|                                                                                                                                                                                                                     | No. 13a Apparatus<br><i>To manufacture for, and supply with coal gas, 1600 burners for 4 hours, or 800 burners for 8 hours, per day each burner consuming 3½ cubic ft. per hour.</i>                                                                                                                                                                                                                                                                                                                                                                                                                                                                                                                                                                                                                                                                                                                                                            | No. 14a Apparatus<br><i>To manufacture for, and supply with coal gas, 2000 burners for 4 hours, or 1,000 burners for 8 hours per day, each burner consuming 3½ cubic ft. per hour.</i>                                                                                                                                                                                                                                                                                                                                                                                                                                                                                                                                                                                                                                                                                                                                                                   |
|---------------------------------------------------------------------------------------------------------------------------------------------------------------------------------------------------------------------|-------------------------------------------------------------------------------------------------------------------------------------------------------------------------------------------------------------------------------------------------------------------------------------------------------------------------------------------------------------------------------------------------------------------------------------------------------------------------------------------------------------------------------------------------------------------------------------------------------------------------------------------------------------------------------------------------------------------------------------------------------------------------------------------------------------------------------------------------------------------------------------------------------------------------------------------------|----------------------------------------------------------------------------------------------------------------------------------------------------------------------------------------------------------------------------------------------------------------------------------------------------------------------------------------------------------------------------------------------------------------------------------------------------------------------------------------------------------------------------------------------------------------------------------------------------------------------------------------------------------------------------------------------------------------------------------------------------------------------------------------------------------------------------------------------------------------------------------------------------------------------------------------------------------|
| <b>RETORT STACK.</b>                                                                                                                                                                                                | Three evaporating pans, 9 furnace bars, 3 dead plates, 3 bearing bars, 2 furnace frames fitted with double doors, 1 10-in. door and frame, 10 shield tiles for furnace doors, 33 sight boxes and covers, 12 pilasters, 6 tie bolts, 3 girder bars, 6 dwarf pilasters and 12 bolts, 3 damper tiles with wrought iron rods, 2 sets of stoking tools, 13 cast iron $\square$ shaped Retorts, each 7 feet long $\times$ 14-in. wide $\times$ 12 in. deep inside measures, 13 mouthpieces and 26 covers for ditto; 78 ¾-in. bolts for mouthpieces, 13 pairs of wrought iron ears, 13 cross-bars, and 13 square-threaded T screws; 13 4-in. saddle flange pipes and bolts; 13 4-in. ascension pipes; 13 4-in. N pipes with cleaning plugs, 13 4-in. dip pipes and bolts; 1 Hydraulic Main, 14-in. diameter, and of sufficient length to receive the dip pipes from all the Retorts with ends and bolts; 4 crutched pillars to support Hydraulic Main. | Four evaporating pans, 12 furnace bars, 4 dead plates, 4 bearing bars, 3 furnace frames fitted with double doors, 1 10-in. furnace door and frame, 14 shield tiles for furnace doors, 46 sight boxes and covers, 14 pilasters, 7 tie bolts, 4 girder bars, 8 dwarf pilasters and 16 bolts, 4 damper tiles with wrought iron rods, 2 sets of stoking tools, 18 cast iron $\square$ shaped Retorts, each 7 feet long $\times$ 14 in. wide $\times$ 12 in. deep inside measures, 18 mouthpieces and 36 covers for ditto; 108 ¾-in. bolts for mouthpieces; 18 pairs of wrought iron ears, 18 cross-bars, and 18 square-threaded T screws; 18 4-in. saddle flange pipes and bolts; 18 4-in. ascension pipes; 18 4-in. N pipes with cleaning plugs, 18 4 in. dip pipes and bolts; 1 Hydraulic Main, 14 in. diameter, and of sufficient length to receive the dip pipes from all the Retorts with ends and bolts; 5 crutched pillars to support Hydraulic Main. |
| <b>CONDENSER.</b>                                                                                                                                                                                                   | One AIR CONDENSER, consisting of 1 bottom box fitted with cleaning doors, 20 5-in. pipes each 9 ft. long, 5 5-in. arch pipes with 2 cleaning plugs to each, 2 dip cisterns 16 in. $\times$ 16 in. $\times$ 21 in. deep, 2 5-in. T pipes and bolts for inlet and outlet.                                                                                                                                                                                                                                                                                                                                                                                                                                                                                                                                                                                                                                                                         | One AIR CONDENSER, consisting of 1 bottom box fitted with cleaning doors, 20 6-in. pipes each 9 feet long, 5 6-in. arch pipes with 2 cleaning plugs to each, 2 dip cisterns, 16 in. $\times$ 16 in. $\times$ 21 in. deep, 2 5-in. T pipes and bolts for inlet and outlet.                                                                                                                                                                                                                                                                                                                                                                                                                                                                                                                                                                                                                                                                                |
| <b>SCRUBBER.</b>                                                                                                                                                                                                    | One SCRUBBER, 3 ft. diameter $\times$ 9 ft. high, fitted with 2 tiers of cast iron grids, 3 filling and discharging doors and frames, with cross-bars, T screws and bolts, 1 water spreader, with 1 in. main cock, key, and syphon pipe; 1 cap and 1 base plate; 2 5-in. dip cisterns 16 in. $\times$ 16 in. $\times$ 21 in. deep, 2 5-in. T pipes and bolts for inlet and outlet; 1 5-in. fourway rising plug valve for by-passing Scrubber.                                                                                                                                                                                                                                                                                                                                                                                                                                                                                                   | One SCRUBBER, 3 ft. diameter $\times$ 9 ft. high, fitted with 2 tiers of cast iron grids, 3 filling and discharging doors and frames, with cross-bars, T screws and bolts, 1 water spreader, with 1 in. main cock, key, and syphon pipe; 1 cap and 1 base plate; 2 4-in. dip cisterns 16 in. $\times$ 16 in. $\times$ 21 in. deep, 2 5-in. T pipes and bolts for inlet and outlet; 1 5-in. fourway rising plug valve for by-passing Scrubber.                                                                                                                                                                                                                                                                                                                                                                                                                                                                                                            |
| <b>PURIFIER.</b>                                                                                                                                                                                                    | Four dry lime PURIFIERS, each 5 ft. $\times$ 4 ft. 6 in. $\times$ 2 ft. 6 in. deep, fitted with 4 tiers of sieves or grids, T bearers, water lutes, and wrought iron cover; 2 lifting carriages and chain slings for removing and replacing covers; 1 5-in. centre change valve for changing the direction of the current of gas in Purifiers.                                                                                                                                                                                                                                                                                                                                                                                                                                                                                                                                                                                                  | Four dry lime PURIFIERS, each 8 ft. $\times$ 3 ft. 6 in. $\times$ 2 ft. 6 in. deep, fitted with 4 tiers of sieves or grids, T bearers, water lute, and wrought iron cover; 2 lifting carriages and chain slings for removing and replacing covers; 1 5-in. centre change valve for changing the direction of the current of gas in Purifiers.                                                                                                                                                                                                                                                                                                                                                                                                                                                                                                                                                                                                            |
| <b>GASHOLDER.</b>                                                                                                                                                                                                   | One GASHOLDER, 45 feet diameter $\times$ 15 feet deep at the sides, containing 24,000 cubic feet of gas; the sheets forming the crown and sides to be of No. 16 Birmingham wire gauge thickness, excepting top and bottom rows, which are to be of No. 14 B. w. g., with strong and suitable internal frame-work; 6 cast-iron Guide columns each 16 feet high; 6 trussed wrought iron girders and bolts to connect the tops of columns; 18 foundation bolts and 6 foundation plates; 6 guide pulleys, with carriages, adjusting plates, axles, and bolts for top of sides, and 12 guide rollers with carriages, axles, and bolts for bottom of sides of Gasholder; 6 caps for tops of columns.                                                                                                                                                                                                                                                  | One GASHOLDER, 50 feet diameter $\times$ 15 feet deep at the sides, containing 30,000 cubic feet of gas; the sheets forming the crown and sides to be of No. 15 Birmingham wire gauge thickness, excepting top and bottom rows, which are to be of No. 14 B. w. g., with strong and suitable internal frame-work; 6 cast iron Guide columns each 16 feet high; 6 trussed wrought iron girders and bolts to connect the tops of columns; 18 foundation bolts and 6 foundation plates; 6 guide pulleys with carriages, adjusting plates, axles, and bolts for top of sides, and 12 guide rollers with carriages, axles, and bolts, for bottom of sides of Gasholder; 6 caps for tops of columns.                                                                                                                                                                                                                                                           |
| <b>CONNECTIONS AND SUNDRIES.</b>                                                                                                                                                                                    | All the necessary 5-in. connecting pipes, not exceeding 100 yards from the Hydraulic Main to condenser, scrubber, purifier into and out of gasholder to outlet valve; also, 30 yards of 4 in. pipe for tar pipe, with bends and T pieces for connecting the tar dip cisterns and from thence to tar well, 2 5-in. rising plug-stop valves for inlet and outlet to Gasholder; 2 5-in. tank syphon boxes, 2 ¾-in. wrought iron suction pipes, 1 brass syphon pump. All bolts, pins, rivets, cement, lead, yarn, red and white lead, paint and oil requisite to fix the above, and to give the whole one coat of metallic oxide paint after completion.<br>42 tons.                                                                                                                                                                                                                                                                                | All the necessary 5-in. connecting pipes, not exceeding 110 yards from the Hydraulic Main to condenser, scrubber, purifiers, into and out of Gasholder to outlet valve; also, 30 yards of 4-in. pipe for tar pipe, with bends and T pieces for connecting the tar dip cisterns and from thence to tar well, 2 5-in. rising plug stop valves for inlet and outlet of Gasholder; 2 5-in. tank syphon boxes, 2 ¾-in. wrought iron suction pipes, 1 brass syphon pump. All bolts, pins, rivets, cement, lead, yarn, red and white lead, paint and oil, requisite to fix the above, and to give the whole one coat of metallic oxide paint after completion.<br>52 tons 10 cwt.                                                                                                                                                                                                                                                                               |
| Total dead weight of ironwork.<br>Measurement additional.<br>Export Price, as per previous specifications.<br>Home Price, as per previous specifications.<br>Quantity of Firebricks, etc., required to set retorts. | 4700 square and 1000 arch bricks; 100 split bricks; 16 pairs of flue lumps, 16 lumps 11 in. $\times$ 6 in. $\times$ 7 in. $\times$ 5 in. thick; 5 T bricks 13 in. $\times$ 9 in.; 20 rebated tiles 22 in. $\times$ 15 in. $\times$ 3 in.; 18 do. 18 in. $\times$ 12 in. $\times$ 3 in.; 14 do. 17 in. $\times$ 12 in. $\times$ 3 in.; 28 do. 17 in. $\times$ 12 in. $\times$ 2½ in.; 15 do. 12 in. $\times$ 9 in. $\times$ 2½ in.; 18 do. 19 in. $\times$ 15 in. $\times$ 3 in.; and 3 tons of fireclay.<br>24 tons 10 cwt.                                                                                                                                                                                                                                                                                                                                                                                                                     | 6500 square bricks and 1400 ash bricks; 24 pair of flue lumps; 24 lumps, 11 in. $\times$ 6 in. 7 in. $\times$ 5 in. thick; 100 split bricks; 30 rebated tiles 22 in. $\times$ 18 in. $\times$ 3 in.; 27 do. 18 in. $\times$ 12 in. $\times$ 3 in.; 21 do. 17 in. $\times$ 12 in. $\times$ 3 in.; 42 tiles 17 in. $\times$ 12 in. $\times$ 2½ in.; 15 tiles 12 in. $\times$ 9 in. $\times$ 2½ in.; 18 tiles 19 in. $\times$ 15 in. $\times$ 3 in.; 5 T bricks 13 in. $\times$ 9 in.; and 4 tons of fireclay.<br>33 tons.                                                                                                                                                                                                                                                                                                                                                                                                                                  |
| Weight of firebricks, etc.<br>Price of Firebricks, etc.<br>Approximate cost of suitable buildings.                                                                                                                  |                                                                                                                                                                                                                                                                                                                                                                                                                                                                                                                                                                                                                                                                                                                                                                                                                                                                                                                                                 |                                                                                                                                                                                                                                                                                                                                                                                                                                                                                                                                                                                                                                                                                                                                                                                                                                                                                                                                                          |

SPECIFICATIONS OF APPARATUS FOR THE MANUFACTURE OF COAL GAS FOR VILLAGES, TOWNS, AND CITIES.

No. 16 Apparatus.  
To manufacture and supply 750,000 cubic feet of coal gas per annum.

RETORT STACK

Two evaporating pans, 6 furnace bars, 2 dead plates, 2 bearing bars, 2 10-in. furnace doors and frames, 4 shield tiles for furnace doors, 10 sight boxes and covers, 10 pilasters, 5 wrought iron tie bolts, 2 girder bars, 4 dwarf pilasters and 8 bolts, 2 damper tiles with wrought iron rods, 3 cast iron  $\square$  shaped Retorts each 6 ft. long  $\times$  14 in. wide  $\times$  12 in. deep inside measures, 3 mouthpieces and 6 covers for ditto; 18  $\frac{1}{4}$ -in. bolts for mouthpieces; 3 pairs of wrought iron ears, 3 cross-bars, and 3 square-threaded T screws; 3 4-in. saddle flange pipes and bolts; 3 4-in. ascension pipes; 3 4-in. N pipes with cleaning plugs, 3 4-in. dip pipes and bolts; 1 Hydraulic Main, 10-in. diameter of bore, and of sufficient length to receive the dip pipes from all the Retorts, with ends and bolts; 3 crutched pillars to support Hydraulic Main.

CONDENSER

One AIR CONDENSER, consisting of 1 bottom box, fitted with cleaning doors, 8 3-in. pipes each 9 ft. long, 4 3-in. arch pipes with 2 cleaning plugs to each, 2 dip cisterns each 14 in.  $\times$  14 in.  $\times$  21 in. deep, 2 3-in. T pipes and bolts for inlet and outlet.

PURIFIERS

Two dry lime PURIFIERS, each 5 ft. long  $\times$  2 ft. 3 in. wide  $\times$  2 ft. 3 in., deep, and fitted with 4 tiers of sieves or grids, resting on ledges cast on side of purifiers, and on wrought iron T bearers, water lutes with wrought iron turn-buckles, wrought iron covers with ground air plugs and frames, and hooks for lifting; 4 covers for inlet and outlet pipes; 1 lifting carriage and chain slings for removing and replacing covers; 2 3 in. four-way rising plug valves for changing the direction of the current of gas in Purifiers, so that either can be shut off or the gas passed through both in succession.

STATION METER

One STATION METER, capable of registering 500 cubic ft. of gas per hour, fitted with water gauge, filling plug, etc.; 1 3-in. fourway, by-pass, and shut-off rising plug valve, to act as by-pass to Station Meter, and stop valve to inlet of Gasholder.

GASHOLDER

One GASHOLDER, 18 ft. diameter  $\times$  10 ft. deep at the sides, containing 2600 cubic ft. of gas; the sheets forming the crown and sides to be of No. 16 Birmingham wire gauge thickness, with strong and suitable internal framework. 3 cast iron Guide Columns, each 11 ft. high; 3 wrought iron girders and bolts to connect the tops of columns; 9 foundation bolts and 3 foundation plates; 3 sets of chain slings, pulleys, axles, carriages, balance weights and bolts; 3 guide pulleys with carriages adjusting plates, axles and bolts for top of sides, and 6 guide rollers, with carriages, axles and bolts for bottom of sides of Gasholder.

GOVERNOR

One STATION GOVERNOR, fitted complete; 1 3-in. fourway, by-pass, and shut-off rising plug valve for by-passing Governor.

CONNECTIONS, ETC.

All the necessary 3 in. pipe, not exceeding 50 yds., with bend and tees, for connecting the Hydraulic Main, condenser, purifiers, station meter, gasholder, and governor, for connecting the tar dip cisterns, and from thence to tar well; 2 3-in. tank syphon boxes, 2  $\frac{1}{2}$  in. wrought iron suction pipes.

SUNDRIES

One  $2\frac{1}{2}$ -in. tar pump, with wrought iron clip for securing to the wall, 1 swivel joint, 1  $\frac{1}{2}$ -in. suction pipe, chain, and shackle; 1 10-in. drain grate and frame, 2 pressure gauges and 1 testcock on boards, with service pipes, bends, and tees.

TOOLS

One set of stoking tools, 1 firing shovel, 1 charging shovel, 1 coke barrow, 1 galvanized iron pail, 1 2-gal. water pot, 1 pair of sight hole tongs, 1 auger for ascension pipes, 1 trowel, 1 coal hammer, 1 sieve, 1 lime shovel, 1 brass syphon pump. All bolts, pins, rivets, cement, lead, yarn, red and white lead, paint and oil, requisite to fix the above, and to give the whole one coat of metallic oxide paint after completion.

Total dead weight of ironwork.  
Measurement in cubic feet additional.

12  $\frac{1}{2}$  tons.

Export Price delivered at the Docks in London, Liverpool, or Hull, inclusive of packing and cases.

Home Price delivered at St. Neots Station, and erected complete in England, exclusive of buildings, foundations, brick or woodwork, or scaffolding.

Quantity of Firebricks, etc., required to set Retorts.

1250 square and 600 arch bricks, 20 split bricks, 5 tiles 21 in.  $\times$  15 in.  $\times$  3 in., 30 tiles 12 in.  $\times$  9 in.  $2\frac{1}{2}$  in., and 17 cwt. of fireclay.

Weight of Firebricks, etc.  
Price of Firebricks, etc., delivered at the Docks in London, Liverpool, or Hull.

6  $\frac{1}{2}$  tons.

SPECIFICATIONS OF APPARATUS FOR VILLAGES, TOWNS AND CITIES—*continued.*

|                                                                                                                                                            | <i>No. 26 Apparatus</i><br><i>To manufacture and supply 1,000,000 cubic feet of coal gas per annum.</i>                                                                                                                                                                                                                                                                                                                                                                                                                                                                                                                                                                                                                                                                                                                                                                                                  |
|------------------------------------------------------------------------------------------------------------------------------------------------------------|----------------------------------------------------------------------------------------------------------------------------------------------------------------------------------------------------------------------------------------------------------------------------------------------------------------------------------------------------------------------------------------------------------------------------------------------------------------------------------------------------------------------------------------------------------------------------------------------------------------------------------------------------------------------------------------------------------------------------------------------------------------------------------------------------------------------------------------------------------------------------------------------------------|
| <b>RETORT STACK</b>                                                                                                                                        | Two evaporating pans, 6 furnace bars, 2 dead plates, 2 bearing bars, 2 10-in. furnace doors and frames, 4 shield ties for furnace doors, 10 sight boxes and covers, 10 pilasters, 5 wrought iron tie bolts, 2 girder bars, 4 dwarf pilasters and 8 bolts, 2 damper tiles with wrought iron rods, 4 cast iron $\square$ shaped Retorts each 7 ft. long $\times$ 14 in. wide $\times$ 12 in. deep inside measures, 4 mouth-pieces and 8 covers for ditto; 24 $\frac{1}{2}$ -in. bolts for mouthpieces; 4 pairs of wrought iron ears, 4 cross-bars, and 4 square-threaded T screws; 4 4-in. saddle flange pipes and bolts; 5 4-in. ascension pipes; 4 4-in. N pipes with cleaning plugs, 4 4-in. dip pipes and bolts; 1 Hydraulic Main, 12 in. diameter of bore, and of sufficient length to receive the dip pipes from all the Retorts, with ends and bolts; 3 crutched pillars to support Hydraulic Main. |
| <b>CONDENSER</b>                                                                                                                                           | One AIR CONDENSER, consisting of 1 bottom box fitted with cleaning doors, 8 3-in. pipes each 9 ft. long, 4 3-in. arch pipes with 2 cleaning plugs to each, 2 dip cisterns each 14 in. $\times$ 14 in. $\times$ 21 in. deep, 2, 3-in. T pipes and bolts for inlet and outlet.                                                                                                                                                                                                                                                                                                                                                                                                                                                                                                                                                                                                                             |
| <b>PURIFIER</b>                                                                                                                                            | Two dry lime PURIFIERS, each 5 ft. long $\times$ 2 ft. 3 in. wide $\times$ 2 ft. 3 in. deep, and fitted with 4 tiers of sieves or grids, resting on ledges cast on sides of purifiers, and on wrought iron T bearers, water lutes with wrought iron turn-buckles, wrought iron covers with ground air plugs and frames, and hooks for lifting; 4 covers for inlet and outlet pipes; 1 lifting carriage and chain slings for removing and replacing covers; 2 3-in. four-way rising plug valves for changing the direction of the current of gas in Purifiers, so that either can be shut off or the gas passed through both in succession.                                                                                                                                                                                                                                                               |
| <b>STATION METER</b>                                                                                                                                       | One STATION METER, capable of registering 500 cubic ft. of gas per hour, fitted with water gauge, filling plug, etc.; 1 3-in. fourway, by-pass, and shut-off rising plug valve, to act as by-pass to Station Meter, and stop valve to inlet of Gasholder.                                                                                                                                                                                                                                                                                                                                                                                                                                                                                                                                                                                                                                                |
| <b>GASHOLDER</b>                                                                                                                                           | 1 GASHOLDER, 22 ft. diameter $\times$ 10 ft. deep at the sides, containing 3800 cubic ft. of gas; the sheets forming the crown and sides to be of No. 16 Birmingham wire gauge thickness, with suitable internal framework. 3 cast iron Guide Columns, each 11 ft. high; 3 wrought iron girders and bolts to connect the tops of columns; 9 foundation bolts and 3 foundation plates; 3 sets of chain slings, pulleys, axles, carriages, balance weights, and bolts, 3 guide pulleys with carriages, adjusting plates, axles and bolts for top of sides, and 6 guide rollers, with carriages, axles and bolts for bottom of sides of Gasholder.                                                                                                                                                                                                                                                          |
| <b>GOVERNOR</b>                                                                                                                                            | One STATION GOVERNOR, fitted complete: 1 3-in. fourway, by-pass, and shut-off rising plug valve for by pass to governor, and stop valve to outlet of Gasholder.                                                                                                                                                                                                                                                                                                                                                                                                                                                                                                                                                                                                                                                                                                                                          |
| <b>CONNECTIONS, ETC.</b>                                                                                                                                   | All the necessary 3-in. pipe, not exceeding 50 yds. with bends and tees, for connecting the Hydraulic Main, condenser, purifier, station meter, gasholder, and governor, for connecting the tar dip cisterns, and from thence to tar well; 2 3-in. tank syphon boxes, 2 $\frac{1}{2}$ -in. wrought iron suction pipes.                                                                                                                                                                                                                                                                                                                                                                                                                                                                                                                                                                                   |
| <b>SUNDRIES</b>                                                                                                                                            | One $2\frac{1}{2}$ -in. tar pump, with wrought iron clip for securing to the wall, 1 swivel joint, 1 $\frac{1}{2}$ -in. suction pipe, chain, and shackle; 1 10-in. drain grate and frame, 2 pressure gauges and 1 testcock on boards, with service pipes, bends, and tees.                                                                                                                                                                                                                                                                                                                                                                                                                                                                                                                                                                                                                               |
| <b>TOOLS</b>                                                                                                                                               | One set of stoking tools, 1 firing shovel, 1 charging shovel, 1 coke barrow, 1 galvanized iron pail, 1 2-gallon water pot, 1 pair of sight hole tongs, 1 auger for ascension pipes, 1 trowel, 1 coal hammer, 1 sieve, 1 lime shovel, 1 brass syphon pump. All bolts, pins, rivets, cement, lead, yarn, red and white lead, paint and oil, requisite to fix the above, and to give the whole one coat of metallic oxide paint after completion.                                                                                                                                                                                                                                                                                                                                                                                                                                                           |
| <b>Total Dead Weight of Ironwork.</b>                                                                                                                      | 14 tons.                                                                                                                                                                                                                                                                                                                                                                                                                                                                                                                                                                                                                                                                                                                                                                                                                                                                                                 |
| <b>Measurement in cubic feet additional.</b>                                                                                                               |                                                                                                                                                                                                                                                                                                                                                                                                                                                                                                                                                                                                                                                                                                                                                                                                                                                                                                          |
| <b>Export Price delivered at the Docks in London, Liverpool, or Hull, inclusive of packing and Cases,</b>                                                  |                                                                                                                                                                                                                                                                                                                                                                                                                                                                                                                                                                                                                                                                                                                                                                                                                                                                                                          |
| <b>Home Price delivered at St. Neots Station, and erected complete in England, exclusive of buildings, foundations, brick or woodwork, or scaffolding.</b> |                                                                                                                                                                                                                                                                                                                                                                                                                                                                                                                                                                                                                                                                                                                                                                                                                                                                                                          |
| <b>Quantity of Firebricks, etc., required to set Retorts.</b>                                                                                              | 1800 square and 650 arch bricks, 100 split bricks, 5 T bricks 13 in. $\times$ 9 in., 22 tiles 12 in. $\times$ 9 in. $\times$ $2\frac{1}{2}$ in.                                                                                                                                                                                                                                                                                                                                                                                                                                                                                                                                                                                                                                                                                                                                                          |
| <b>Weight of Firebricks, etc.</b>                                                                                                                          | 18 tiles 19 in. $\times$ 15 in. $\times$ 3 in., and 24 cwt. of fireclay.                                                                                                                                                                                                                                                                                                                                                                                                                                                                                                                                                                                                                                                                                                                                                                                                                                 |
| <b>Price of Firebricks, etc., delivered at the Docks in London, Liverpool, or Hull.</b>                                                                    | 9 tons 6 cwt.                                                                                                                                                                                                                                                                                                                                                                                                                                                                                                                                                                                                                                                                                                                                                                                                                                                                                            |

SPECIFICATIONS OF APPARATUS FOR VILLAGES, TOWNS, AND CITIES.—*continued.*

| <i>No. 3b Apparatus</i><br><i>For the manufacture and supply of 1,250,000 cubic feet of coal gas per annum.</i>                                     |                                                                                                                                                                                                                                                                                                                                                                                                                                                                                                                                                                                                                                                                                                                                                                                                                                                                                                       |
|-----------------------------------------------------------------------------------------------------------------------------------------------------|-------------------------------------------------------------------------------------------------------------------------------------------------------------------------------------------------------------------------------------------------------------------------------------------------------------------------------------------------------------------------------------------------------------------------------------------------------------------------------------------------------------------------------------------------------------------------------------------------------------------------------------------------------------------------------------------------------------------------------------------------------------------------------------------------------------------------------------------------------------------------------------------------------|
| <b>RETORT STACK</b>                                                                                                                                 | Two evaporating pans, 6 furnace bars, 2 dead plates, 2 bearing bars, 12 sight boxes and covers, 2 10-in. furnace doors and frames, 4 shield tiles for furnace doors, 10 pilasters, 5 wrought iron tie bolts, 2 girder bars, 4 dwarf pilasters and 8 bolts, 2 damper tiles, with wrought iron rods, 5 cast iron $\square$ shaped Retorts 7 ft. long $\times$ 14 in. wide $\times$ 12 in. deep inside measures, 5 mouthpieces and 10 covers for ditto; 30 $\frac{1}{2}$ -in. bolts for mouth pieces; 5 pairs of wrought iron ears, 5 cross-bars, and 5 square-threaded T screws; 5 4-in. saddle flange pipes and bolts; 5 4-in. ascension pipes; 5 4-in. N pipes with cleaning plugs, 5 4-in. dip pipes and bolts; 1 Hydraulic Main, 12 in. diameter of bore and of sufficient length to receive the dip pipes from all the Retorts, with ends and bolts; 3 crutched pillars to support Hydraulic Main. |
| <b>CONDENSER</b>                                                                                                                                    | One AIR CONDENSER, consisting of 1 bottom box fitted with cleaning doors, 12 3-in. pipes each 9 ft. long, 6 3-in. arch pipes with 2 cleaning plugs to each, 2 dip cisterns each 14 in. $\times$ 14 in. $\times$ 21 in. deep, 2 3-in. T pipes and bolts for inlet and outlet.                                                                                                                                                                                                                                                                                                                                                                                                                                                                                                                                                                                                                          |
| <b>PURIFIERS</b>                                                                                                                                    | TWO LIME PURIFIERS, each 5 ft. long $\times$ 2 ft. 3 in. wide $\times$ 2 ft. 3 in. deep, and fitted with 4 tiers of sieves or grids, resting on ledges cast on the side of purifiers, and on wrought iron T bearers, water lutes with wrought iron turn-buckles, wrought iron covers with ground air plug and frames, and hooks for lifting; 4 covers for inlet and outlet pipes; 1 lifting carriage and chain slings for removing and replacing covers; 2 3-in. fourway rising plug valves for changing the direction of the current of gas in Purifiers, so that either can be shut off or the gas passed through both in succession.                                                                                                                                                                                                                                                               |
| <b>STATION METER</b>                                                                                                                                | One STATION METER, capable of registering 500 cubic feet of gas per hour, fitted with water gauge, filling plug, etc.; 1 3-in. fourway, by-pass, and shut-off rising plug valve, to act as by-pass to Station Meter, and stop valve to inlet of Gasholder.                                                                                                                                                                                                                                                                                                                                                                                                                                                                                                                                                                                                                                            |
| <b>GASHOLDER</b>                                                                                                                                    | One GASHOLDER, 25 feet diameter $\times$ 10 feet deep at the sides, containing 5000 cubic feet of gas; the sheets forming the crown and sides to be of No. 16 Birmingham wire gauge thickness, with strong and suitable internal framework. 4 cast iron Guide columns each 11 feet high; 4 wrought iron girders and bolts to connect the tops of columns; 12 foundation bolts and 4 foundation plates; 4 guide pulleys, with carriages, adjusting plates, axles, and bolts for top of sides, and 8 guide rollers with carriages, axles, and bolts for bottom of sides of Gasholder; 4 caps for top of columns.                                                                                                                                                                                                                                                                                        |
| <b>GOVERNOR</b>                                                                                                                                     | One STATION GOVERNOR, fitted complete; 1 3-in. fourway, by-pass, and shut-off rising plug valve for by-pass to Governor, and stop valve to outlet of Gas-holder.                                                                                                                                                                                                                                                                                                                                                                                                                                                                                                                                                                                                                                                                                                                                      |
| <b>CONNECTIONS, ETC.</b>                                                                                                                            | All necessary 3-in. pipe, not exceeding 50 yards with bends and T pieces for connecting the Hydraulic Main, condenser, purifiers, station meter, gasholder and governor, for connecting the tar dip cisterns and from thence to tar well; 10 yds. of 4-in. pipe for outlet from holder; 1 3-in. and 1 4-in. tank syphon box, 2 $\frac{1}{2}$ -in. wrought iron suction pipes.                                                                                                                                                                                                                                                                                                                                                                                                                                                                                                                         |
| <b>SUNDRIES</b>                                                                                                                                     | One 2 $\frac{1}{2}$ -in. tar pump, with wrought iron clip for securing to the wall, 1 swivel joint, 1 $\frac{1}{2}$ -in. suction pipe, chain and shackle; 1 10-in. drain grate and frame; 2 pressure gauges and 1 testcock on boards, with service pipes, bends and T pieces.                                                                                                                                                                                                                                                                                                                                                                                                                                                                                                                                                                                                                         |
| <b>TOOLS</b>                                                                                                                                        | One set of stoking tools, 1 firing shovel, 1 charging shovel, 1 coke barrow, 1 galvanized iron pail, 1 2-gallon water pot, 1 pair of sight hole tongs, 1 auger for ascension pipes, 1 trowel, 1 coal hammer, 1 retort lid cleaner, 2 lime sieves, 1 lime shovel, 1 brass syphon pump. To provide all bolts, pins, rivets, cement, lead, yarn, red and white lead, paint and oil, requisite to fix the above, and to give the whole one coat of metallic oxide paint after completion.                                                                                                                                                                                                                                                                                                                                                                                                                 |
| Total dead weight of Ironwork.                                                                                                                      | 16 tons.                                                                                                                                                                                                                                                                                                                                                                                                                                                                                                                                                                                                                                                                                                                                                                                                                                                                                              |
| Measurement in cubic feet additional.                                                                                                               |                                                                                                                                                                                                                                                                                                                                                                                                                                                                                                                                                                                                                                                                                                                                                                                                                                                                                                       |
| Export Price delivered at the Docks in London, Liverpool, or Hull, inclusive of packing and Cases.                                                  |                                                                                                                                                                                                                                                                                                                                                                                                                                                                                                                                                                                                                                                                                                                                                                                                                                                                                                       |
| Home Price delivered at St. Neots Station, and erected complete in England, exclusive of buildings, foundations, brick or woodwork, or scaffolding. |                                                                                                                                                                                                                                                                                                                                                                                                                                                                                                                                                                                                                                                                                                                                                                                                                                                                                                       |
| Quantity of Firebricks, etc. required to set Retorts.                                                                                               | 2,000 square and 650 arch bricks, 100 split bricks, 5 T bricks 13 in. $\times$ 9 in., 45 tiles 12-in. $\times$ 9 in. $\times$ 2 $\frac{1}{2}$ in., 18 tiles 19 in. $\times$ 15 in. $\times$ 3 in., 5 tiles 21 in. $\times$ 15 in. $\times$ 3 in., and 26 cwt. of fireclay.                                                                                                                                                                                                                                                                                                                                                                                                                                                                                                                                                                                                                            |
| Weight of Firebricks, etc.                                                                                                                          | 11 tons 5 cwt.                                                                                                                                                                                                                                                                                                                                                                                                                                                                                                                                                                                                                                                                                                                                                                                                                                                                                        |
| Price of Firebricks, etc., delivered at the Docks in London, Liverpool, or Hull.                                                                    |                                                                                                                                                                                                                                                                                                                                                                                                                                                                                                                                                                                                                                                                                                                                                                                                                                                                                                       |

GEORGE BOWER, ST. NEOTS, HUNTINGDONSHIRE.

SPECIFICATIONS OF APPARATUS FOR VILLAGES, TOWNS, AND CITIES—continued.

|                                                                                                                                                     |  | <i>No. 4b Apparatus</i><br><i>For the manufacture and supply of 1,500,000 cubic feet of coal gas per annum.</i>                                                                                                                                                                                                                                                                                                                                                                                                                                                                                                                                                                                                                                                                                                                                                                                                 |
|-----------------------------------------------------------------------------------------------------------------------------------------------------|--|-----------------------------------------------------------------------------------------------------------------------------------------------------------------------------------------------------------------------------------------------------------------------------------------------------------------------------------------------------------------------------------------------------------------------------------------------------------------------------------------------------------------------------------------------------------------------------------------------------------------------------------------------------------------------------------------------------------------------------------------------------------------------------------------------------------------------------------------------------------------------------------------------------------------|
| RETORT STACK                                                                                                                                        |  | Three evaporating pans, 9 furnace bars, 3 dead plates, 3 bearing bars, 15 sight boxes and covers, 3 10-in. furnace doors and frames, 6 shield tiles for furnace doors, 12 pilasters, 6 wrought iron tie bolts, 3 girder bars, 6 dwarf pilasters and 12 bolts, 3 damper tiles, with wrought iron rods, 6 cast iron $\square$ shaped Retorts each 7 feet long $\times$ 14 in. wide $\times$ 12 in. deep, inside measures, 6 mouth-pieces and 12 covers for ditto; 36 $\frac{3}{4}$ -in. bolts for mouthpieces; 6 pairs of wrought iron ears, 6 cross-bars, and 6 square-threaded T screws; 6 4-in. saddle flange pipes and bolts; 6 4-in. ascension pipes; 6 4-in. N pipes with cleaning plugs, 6 4-in. dip pipes and bolts, 1 Hydraulic Main, 12-in. diameter of bore and of sufficient length to receive the dip pipes from all the Retorts, with ends and bolts; 3 crutched pillars to support Hydraulic Main. |
| CONDENSER                                                                                                                                           |  | One AIR CONDENSER, consisting of bottom box fitted with cleaning doors, 10 4-in. pipes each 9 feet long, 5 4-in. arch pipes with 2 cleaning caps to each, 2 dip cisterns each 14 in. $\times$ 14 in. $\times$ 21 in. deep, 2 3-in. T pipes and bolts for inlet and outlet.                                                                                                                                                                                                                                                                                                                                                                                                                                                                                                                                                                                                                                      |
| PURIFIERS                                                                                                                                           |  | Two dry lime PURIFIERS, each 6 feet long $\times$ 2 ft. 6 in. wide $\times$ 2 ft. 6 in. deep, and fitted with 4 tiers of sieves or grids, resting on ledges cast on the sides of purifiers, and on wrought iron T bearers, water lutes with wrought iron turn-buckles, wrought iron covers with ground air plugs and frames, and hooks for lifting; 4 covers for inlet and outlet pipes; 1 lifting carriage and chain slings for removing and replacing covers; 2 3-in. fourway rising plug valves for changing the direction of the current of gas in Purifiers, so that either can be shut off or the gas passed through both in succession.                                                                                                                                                                                                                                                                  |
| STATION METER                                                                                                                                       |  | One STATION METER, capable of registering 750 cubic feet of gas per hour, fitted with water gauge, filling plug, etc.; 1 3-in. fourway, by-pass, and shut-off rising plug valve, to act as by-pass to Station Meter, and stop valve to inlet of Gasholder.                                                                                                                                                                                                                                                                                                                                                                                                                                                                                                                                                                                                                                                      |
| GASHOLDER                                                                                                                                           |  | One GASHOLDER, 30 feet diameter $\times$ 10 feet deep at the sides, containing 7,000 cubic feet of gas; the sheets forming the crown and sides to be of No. 16 Birmingham wire gauge thickness, with strong and suitable internal framework, 4 cast iron Guide columns each 11 feet high; 4 trussed wrought iron girders and bolts to connect the tops of columns; 12 foundation bolts and 4 foundation plates; 4 guide pulleys with carriages, adjusting plates, axles, and bolts for top of sides, and 8 guide rollers with carriages, axles, and bolts for bottom of sides of Gasholder, 4 caps for top of columns.                                                                                                                                                                                                                                                                                          |
| GOVERNOR                                                                                                                                            |  | One STATION GOVERNOR, fitted complete; 1 3-in. fourway, by-pass, and shut-off rising plug valve to act as by-pass to governor, and as stop valve to outlet of Gasholder.                                                                                                                                                                                                                                                                                                                                                                                                                                                                                                                                                                                                                                                                                                                                        |
| CONNECTIONS, ETC.                                                                                                                                   |  | All the necessary 3-in. pipe, not exceeding 60 yards, with bends and T pieces for connecting the Hydraulic Main, condenser, purifiers, station meter, gasholder, and governor, for connecting the tar dip cisterns, and from thence to tar well; also 10 yds. of 4-in. pipe for outlet from gasholder, 1 3-in. and 1 4-in. tank syphons, 2 $\frac{3}{4}$ -in. wrought iron suction pipes.                                                                                                                                                                                                                                                                                                                                                                                                                                                                                                                       |
| SUNDRIES                                                                                                                                            |  | One 2 $\frac{1}{2}$ -in. tar pump, with wrought iron clip for securing to the wall, 1 swivel joint, 1 $\frac{1}{2}$ -in. suction pipe, chain, and shackle; 1 10-in. drain grate and frame. 2 pressure gauges and 1 testcock on boards, with service pipes, bends, and T pieces.                                                                                                                                                                                                                                                                                                                                                                                                                                                                                                                                                                                                                                 |
| TOOLS                                                                                                                                               |  | One set of stoking tools, 1 firing shovel, 1 charging shovel, 1 coke barrow, 1 galvanized iron pail, 1 2-gal. water pot, 1 pair of sight hole tongs, 1 auger for ascension pipes, 1 trowel, 1 coal hammer, 1 retort lid cleaner, 2 lime sieves, 1 lime shovel, 1 brass syphon pump. All bolts, pins, rivets, cement, lead, yarn, red and white lead, paint and oil, requisite to fix the above, and to give the whole one coat of metallic oxide paint after completion.                                                                                                                                                                                                                                                                                                                                                                                                                                        |
| Total dead weight of Ironwork.                                                                                                                      |  | 20 tons.                                                                                                                                                                                                                                                                                                                                                                                                                                                                                                                                                                                                                                                                                                                                                                                                                                                                                                        |
| Measurement in cubic feet additional.                                                                                                               |  |                                                                                                                                                                                                                                                                                                                                                                                                                                                                                                                                                                                                                                                                                                                                                                                                                                                                                                                 |
| Export Price delivered at the Docks in London, Liverpool, or Hull, inclusive of packing and Cases.                                                  |  |                                                                                                                                                                                                                                                                                                                                                                                                                                                                                                                                                                                                                                                                                                                                                                                                                                                                                                                 |
| Home Price delivered at St. Neots Station, and erected complete in England, exclusive of buildings, foundations, brick or woodwork, or scaffolding. |  |                                                                                                                                                                                                                                                                                                                                                                                                                                                                                                                                                                                                                                                                                                                                                                                                                                                                                                                 |
| Quantity of Firebricks, etc., required to set Retorts.                                                                                              |  | 2,600 square and 1,000 arch bricks, 120 split bricks, 5 T bricks 13 in. $\times$ 9 in., 52 tiles 12 in. $\times$ 9 in. $\times$ 2 $\frac{1}{2}$ in. 18 tiles 19 in. $\times$ 15 in. $\times$ 3 in., 5 tiles 21 in. $\times$ 15 in. $\times$ 3 in., and 35 cwt. of fireclay.                                                                                                                                                                                                                                                                                                                                                                                                                                                                                                                                                                                                                                     |
| Weight of Firebricks, etc.                                                                                                                          |  | 14 tons 15 cwt.                                                                                                                                                                                                                                                                                                                                                                                                                                                                                                                                                                                                                                                                                                                                                                                                                                                                                                 |
| Price of Firebricks, etc., delivered at the Docks in London, Liverpool, or Hull.                                                                    |  |                                                                                                                                                                                                                                                                                                                                                                                                                                                                                                                                                                                                                                                                                                                                                                                                                                                                                                                 |



SPECIFICATIONS OF APPARATUS FOR VILLAGES, TOWNS, AND CITIES—*continued.*

*No. 5b Apparatus.*  
For the manufacture and supply of 2,250,000 cubic feet of coal gas per annum.

|                          |                                                                                                                                                                                                                                                                                                                                                                                                                                                                                                                                                                                                                                                                                                                                                                                                                                                                                                                                                 |
|--------------------------|-------------------------------------------------------------------------------------------------------------------------------------------------------------------------------------------------------------------------------------------------------------------------------------------------------------------------------------------------------------------------------------------------------------------------------------------------------------------------------------------------------------------------------------------------------------------------------------------------------------------------------------------------------------------------------------------------------------------------------------------------------------------------------------------------------------------------------------------------------------------------------------------------------------------------------------------------|
| <b>RETORT STACK</b>      | Three evaporating pans, 9 furnace bars, 3 dead plates, 3 bearing bars, 21 sight boxes and covers, 2 10-in. furnace doors and frames, 1 furnace frame with double doors, 8 shield tiles for furnace doors, 12 pilasters, 6 wrought iron tie bolts, 3 girder bars, 6 dwarf pilasters and 12 bolts, 3 damper tiles with wrought iron rods, 8 cast iron $\square$ shaped Retorts each 7 ft. long $\times$ 14 in. wide $\times$ 12 in. deep inside measures, 8 mouthpieces and 16 covers for ditto; 48 $\frac{3}{4}$ -in. bolts for mouthpieces; 8 pairs of wrought iron ears, 8 cross-bars, and 8 square-threaded T screws; 8 4-in. saddle flange pipes and bolts; 8 4-in. ascension pipes; 8 4-in. N pipes with cleaning plugs, 8 4-in. dip pipes and bolts; 1 Hydraulic Main, 14-in. diameter of bore, and of sufficient length to receive the dip pipes from all the Retorts, with ends and bolts; 4 crutched pillars to support Hydraulic Main. |
| <b>CONDENSER</b>         | One AIR CONDENSER, consisting of 1 bottom box, fitted with cleaning doors, 14 4-in. pipes each 9 ft. long, 7 4-in. arch pipes with 2 cleaning plugs to each, 2 dip cisterns each 14 in. $\times$ 14 in. $\times$ 21 in. deep, 2 4-in. T pipes and bolts for inlet and outlet.                                                                                                                                                                                                                                                                                                                                                                                                                                                                                                                                                                                                                                                                   |
| <b>SCRUBBER</b>          | One SCRUBBER, 2 ft. diameter $\times$ 9 ft. high, fitted with 2 tiers of cast iron grids, 3 filling and discharging doors and frames, with cross-bars, T screws and bolts; 1 water spreader with 1 in. main cock, key and syphon pipe; 1 cap and 1 base plate, 2 dip cisterns 14 in. $\times$ 14 in. $\times$ 21 in. deep, 2 4-in. T pipes and bolts for inlet and outlet; 1 4-in. fourway rising plug valve for by-passing scrubber.                                                                                                                                                                                                                                                                                                                                                                                                                                                                                                           |
| <b>PURIFIERS</b>         | Two dry lime PURIFIERS, each 5 ft. long $\times$ 4 ft. wide $\times$ 2 ft. 6 in., deep, and fitted with 4 tiers of sieves or grids, resting on ledges cast on side of purifiers, and on wrought iron T bearers, water lutes with wrought iron turn-buckles, wrought iron covers with ground air plugs and frames, and hooks for lifting; 2 covers for inlet pipes; 1 lifting carriage and chain slings for removing and replacing covers; 2 4 in. four-way rising plug valves for changing the direction of the current of gas in Purifiers, so that either can be shut off or the gas passed through both in succession.                                                                                                                                                                                                                                                                                                                       |
| <b>STATION METER</b>     | One STATION METER, capable of registering 750 cubic ft. of gas per hour, fitted with water gauge, filling plug, etc.; 1 4-in. fourway, by-pass, and shut-off rising plug valve, to act as by-pass to Station Meter, and stop valve to inlet of Gasholder.                                                                                                                                                                                                                                                                                                                                                                                                                                                                                                                                                                                                                                                                                       |
| <b>GASHOLDER</b>         | One GASHOLDER, 35 ft. diameter $\times$ 12 ft. deep at the sides, containing 11,500 cubic ft. of gas; the sheets forming the crown and sides to be of No. 16 Birmingham wire gauge thickness, with strong and suitable internal framework. 5 cast iron Guide Columns, each 13 ft. high; 5 trussed wrought iron girders and bolts to connect the tops of columns; 15 foundation bolts and 5 foundation plates; 5 guide pulleys with carriages, adjusting plates, axles and bolts for top of sides, and 10 guide rollers, with carriages, axles and bolts for bottom of sides of Gasholder, 5 caps for top of columns.                                                                                                                                                                                                                                                                                                                            |
| <b>GOVERNOR</b>          | One STATION GOVERNOR, fitted complete; 1 4-in. fourway, by-pass, and shut-off rising plug valve to act as by-pass to Governor, and as stop valve to outlet of gasholder.                                                                                                                                                                                                                                                                                                                                                                                                                                                                                                                                                                                                                                                                                                                                                                        |
| <b>CONNECTIONS, ETC.</b> | All the necessary 4 in. pipe, not exceeding 90 yds., with bends and T pieces for connecting the Hydraulic Main, condenser, scrubber, purifiers, station meter, gasholder, and governor, for connecting the tar dip cisterns, and from thence to tar well; 2 4-in. tank syphon boxes, 2 $\frac{1}{2}$ -in. wrought iron suction pipes.                                                                                                                                                                                                                                                                                                                                                                                                                                                                                                                                                                                                           |
| <b>SUNDRIES</b>          | One 2 $\frac{1}{2}$ -in. water pump, with bolts and plates for fixing to wall, 1 $\frac{1}{2}$ -in. suction and 1 in. delivery pipe, with bends and connections; 1 wrought iron cistern to contain 100 gallons; 1 1-in. supply pipe and connection from cisterns to scrubber; 1 1-in. supply pipe from cistern to retort house, with $\frac{3}{4}$ -in. draw off cock and key. 1 3 $\frac{1}{2}$ -in. tar pump, with wrought iron clip for securing to wall, 1 swivel joint, 1 $\frac{1}{2}$ -in. suction pipe, chain and shackle, 1 10-in. drain grate and frame, 2 pressure gauges and 1 testcock on boards, with service pipes, bends, and tees.                                                                                                                                                                                                                                                                                             |
| <b>TOOLS</b>             | One set of stoking tools, 1 firing shovel, 1 charging shovel, 1 coke barrow, 1 galvanized iron pail, 1 2-gal. water pot, 1 pair of sight hole tongs, 1 auger for ascension pipes, 1 trowel, 1 coal hammer, 1 retort lid cleaner, 2 lime sieves, 1 lime shovel, 1 brass syphon pump. All bolts, pins, rivets, cement, lead, yarn, red and white lead, paint and oil, requisite to fix the above, and to give the whole one coat of metallic oxide paint after completion.                                                                                                                                                                                                                                                                                                                                                                                                                                                                        |

Total dead weight of ironwork.  
Measurement in cubic feet additional.

28 tons.

Export Price delivered at the Docks in London, Liverpool, or Hull, inclusive of packing and Cases.

Home Price delivered at St. Neots Station, and erected complete in England, exclusive of buildings, foundations, brick or woodwork, or scaffolding.

Quantity of Firebricks, etc., required to set Retorts.

3200 square and 950 arch bricks, 200 split bricks, 10 T bricks 13 in.  $\times$  9 in., 60 tiles 12 in.  $\times$  9 in.  $\times$  2 $\frac{1}{2}$  in., 36 tiles 19 in.  $\times$  15 in.  $\times$  3 in., 5 tiles 21 in.  $\times$  15 in.  $\times$  3 in., and 41 cwt. of fireclay.

Weight of Firebricks, etc.

18 tons.

Price of Firebricks, etc., delivered at the Docks in London, Liverpool, or Hull.

## SPECIFICATIONS OF APPARATUS FOR VILLAGES, TOWNS AND CITIES—continued.

|                                                                                                                                                      |  | No. 6b Apparatus<br>To manufacture and supply 3,000,000 cubic feet of coal gas per annum.                                                                                                                                                                                                                                                                                                                                                                                                                                                                                                                                                                                                                                                                                                                                                                                                                                                               |
|------------------------------------------------------------------------------------------------------------------------------------------------------|--|---------------------------------------------------------------------------------------------------------------------------------------------------------------------------------------------------------------------------------------------------------------------------------------------------------------------------------------------------------------------------------------------------------------------------------------------------------------------------------------------------------------------------------------------------------------------------------------------------------------------------------------------------------------------------------------------------------------------------------------------------------------------------------------------------------------------------------------------------------------------------------------------------------------------------------------------------------|
| RETORT STACK                                                                                                                                         |  | Three evaporating pans, 9 furnace bars, 3 dead plates, 3 bearing bars, 25 sight boxes and covers, 2 10-in. furnace doors and frames, 1 furnace frame with double doors, 8 shield ties for furnace doors, 12 pilasters, 6 wrought iron tie bolts, 3 girder bars, 6 dwarf pilasters and 12 bolts, 3 damper tiles with wrought iron rods, 10 cast iron $\square$ shaped Retorts each 7 ft. long $\times$ 14 in. wide $\times$ 12 in. deep inside measures, 10 mouthpieces and 20 covers for ditto; 60 $\frac{3}{4}$ -in. bolts for mouthpieces; 10 pairs of wrought iron ears, 10 cross bars, and 10 square-threaded T screws; 10 4-in. saddle flange pipes and bolts; 10 4-in. ascension pipes; 10 4-in. N pipes with cleaning plugs, 10 4-in. dip pipes and bolts; 1 Hydraulic Main, 14 in. diameter of bore, and of sufficient length to receive the dip pipes from all the Retorts, with ends and bolts; 4 crutched pillars to support Hydraulic Main. |
| CONDENSER                                                                                                                                            |  | One AIR CONDENSER, consisting of 1 bottom box fitted with cleaning doors, 12 5-in. pipes each 9 ft. long, 6 5-in. arch pipes with 2 cleaning plugs to each, 2 dip cisterns each 14 in. $\times$ 14 in. $\times$ 21 in. deep, 2 4-in. T pipes and bolts for inlet and outlet.                                                                                                                                                                                                                                                                                                                                                                                                                                                                                                                                                                                                                                                                            |
| SCRUBBER                                                                                                                                             |  | One SCRUBBER, 2 ft. diameter $\times$ 9 ft. high, fitted with 2 tiers of cast iron grids, 3 filling and discharging doors and frames, with cross-bars, T screws, and bolts; 1 water spreader with 1-in. main cock, key, and syphon pipe; 1 cap and 1 base plate, 2 dip cisterns 14 in. $\times$ 14 in. $\times$ 21 in. deep, 2 4-in. T pipes and bolts for inlet and outlet; 1 4-in. fourway rising plug valve for by-passing scrubber.                                                                                                                                                                                                                                                                                                                                                                                                                                                                                                                 |
| PURIFIERS                                                                                                                                            |  | Two dry lime PURIFIERS, each 8 ft. long $\times$ 3 ft. 6 in. wide $\times$ 2 ft. 6 in. deep, and fitted with 4 tiers of sieves or grids, resting on ledges east on sides of purifiers, and on wrought iron T bearers, water lutes with wrought iron turn-buckles, wrought iron covers with ground air plugs and frames, and hooks for lifting; 4 covers for inlet pipes; 1 lifting carriage and chain slings for removing and replacing covers; 2 4-in. four-way rising plug valves for changing the direction of the current of gas in Purifiers, so that either can be shut off or the gas passed through both in succession.                                                                                                                                                                                                                                                                                                                         |
| STATION METER                                                                                                                                        |  | One STATION METER, capable of registering 1000 cubic ft. of gas per hour, fitted with water gauge, filling plug, etc.; 1 4-in. fourway, by-pass, and shut-off rising plug valve, to act as by-pass to Station Meter, and stop valve to inlet of Gasholder.                                                                                                                                                                                                                                                                                                                                                                                                                                                                                                                                                                                                                                                                                              |
| GASHOLDER                                                                                                                                            |  | 1 GASHOLDER, 40 ft. diameter $\times$ 12 ft. deep at the sides, containing 15,000 cubic ft. of gas; the sheets forming the crown and sides to be of No. 15 Birmingham wire gauge thickness, with strong and suitable internal framework. 5 cast iron Guide Columns, each 13 ft. high; 5 trussed wrought iron girders and bolts to connect the tops of columns; 15 foundation bolts and 5 foundation plates; 5 guide pulleys with carriages, adjusting plates, axles and bolts for top of sides, and 10 guide rollers, with carriages, axles, and bolts for bottom of sides of Gasholder, 5 caps for top of columns.                                                                                                                                                                                                                                                                                                                                     |
| GOVERNOR                                                                                                                                             |  | One STATION GOVERNOR, fitted complete: 1 5-in. fourway, by-pass, and shut-off rising plug valve to act as by pass to governor, and as stop valve to outlet of Gasholder.                                                                                                                                                                                                                                                                                                                                                                                                                                                                                                                                                                                                                                                                                                                                                                                |
| CONNECTIONS, ETC.                                                                                                                                    |  | All the necessary 4-in. pipe, not exceeding 60 yds. with bends and T pieces, for connecting the Hydraulic Main, condenser, scrubber, purifiers, station meter, and gasholder, and 30 yds. of 5-in. pipe with bends and T pieces for connecting the gasholder and governor, also 20 yds. of 4-in. pipe for connecting the tar dip cisterns, and from thence to tar well; 1 4-in. and 1 5-in. tank syphon boxes, 2 $\frac{3}{4}$ -in. wrought iron suction pipes.                                                                                                                                                                                                                                                                                                                                                                                                                                                                                         |
| SUNDRIES                                                                                                                                             |  | One $2\frac{1}{2}$ -in. lift and force pump for water with bolts and plates for fixing to wall, $1\frac{1}{2}$ -in. suction and 1-in. delivery pipe with bends and connections; 1 wrought iron cistern to contain 100 gallons; 1 1-in. supply pipe and connections from cistern to scrubber; 1 1-in. supply pipe and connections from cistern to retort house with $\frac{3}{4}$ -in. draw off cock and key. 1 $3\frac{1}{2}$ -in. tar pump, with wrought iron clip for securing to the wall, 1 swivel joint, $1\frac{1}{2}$ -in. suction pipe chain, and shackle; 1 10-in. drain grate and frame. 2 pressure gauges and 1 testcock on boards, with service pipes, bends, and tees.                                                                                                                                                                                                                                                                     |
| TOOLS                                                                                                                                                |  | One set of stoking tools, 1 firing shovel, 1 charging shovel, 1 coke barrow, 1 galvanized iron pail, 1 2-gallon water pot, 1 pair of sight hole tongs, 1 auger for ascension pipes, 1 trowel, 1 coal hammer, 1 retort lid cleaner, 2 lime sieves, 1 lime shovel, 1 brass syphon pump. All bolts, pins, rivets, cement, lead, yarn, red and white lead, paint and oil, requisite to fix the above, and to give the whole one coat of metallic oxide paint after completion.                                                                                                                                                                                                                                                                                                                                                                                                                                                                              |
| Total Dead Weight of Ironwork.                                                                                                                       |  | 34 tons.                                                                                                                                                                                                                                                                                                                                                                                                                                                                                                                                                                                                                                                                                                                                                                                                                                                                                                                                                |
| Measurement in cubic feet additional.                                                                                                                |  |                                                                                                                                                                                                                                                                                                                                                                                                                                                                                                                                                                                                                                                                                                                                                                                                                                                                                                                                                         |
| Export Price delivered at the Docks in London, Liverpool, or Hull, inclusive of packing and Cases,                                                   |  |                                                                                                                                                                                                                                                                                                                                                                                                                                                                                                                                                                                                                                                                                                                                                                                                                                                                                                                                                         |
| Home Price delivered at St. Neots Station, and erected complete in England, exclusive of buildings, foundations, brick or wood-work, or scaffolding. |  |                                                                                                                                                                                                                                                                                                                                                                                                                                                                                                                                                                                                                                                                                                                                                                                                                                                                                                                                                         |
| Quantity of Firebricks, etc., required to set Retorts.                                                                                               |  | 3800 square and 1000 arch bricks, 100 split bricks, 8 pairs of flue lumps, 8 lumps 11 in. $\times$ 6 in. $\times$ 7 in. $\times$ 5 in.; 5 T bricks 13 in. $\times$ 9 in., 10 tiles 22 in. $\times$ 13 in. $\times$ 3 in., 5 tiles 21 in. $\times$ 15 in. $\times$ 3 in., 18 tiles 19 in. $\times$ 15 in. $\times$ 3 in., 9 tiles 18 in. $\times$ 12 in. $\times$ 3 in., 7 tiles 17 in. $\times$ 12 in. $\times$ 3 in., 14 tiles 17 in. $\times$ 12 in. $\times$ 2 $\frac{1}{2}$ in., 15 tiles 12 in. $\times$ 9 in. $\times$ 2 $\frac{1}{2}$ in., 30 tiles 12 in. $\times$ 9 in. $\times$ 2 in., and 46 cwt. of fireclay.                                                                                                                                                                                                                                                                                                                               |
| Weight of Firebricks, etc.                                                                                                                           |  | 19 tons 10 cwt.                                                                                                                                                                                                                                                                                                                                                                                                                                                                                                                                                                                                                                                                                                                                                                                                                                                                                                                                         |
| Price of Firebricks, etc., delivered at the Docks in London, Liverpool, or Hull.                                                                     |  |                                                                                                                                                                                                                                                                                                                                                                                                                                                                                                                                                                                                                                                                                                                                                                                                                                                                                                                                                         |

SPECIFICATIONS OF APPARATUS FOR VILLAGES, TOWNS, AND CITIES—*continued.*

No. 7b Apparatus

For the manufacture and supply of 4,500,000 cubic feet of coal gas per annum.

|                          |                                                                                                                                                                                                                                                                                                                                                                                                                                                                                                                                                                                                                                                                                                                                                                                                                                                                                                                                                                                                                                                                                                                               |
|--------------------------|-------------------------------------------------------------------------------------------------------------------------------------------------------------------------------------------------------------------------------------------------------------------------------------------------------------------------------------------------------------------------------------------------------------------------------------------------------------------------------------------------------------------------------------------------------------------------------------------------------------------------------------------------------------------------------------------------------------------------------------------------------------------------------------------------------------------------------------------------------------------------------------------------------------------------------------------------------------------------------------------------------------------------------------------------------------------------------------------------------------------------------|
| <b>RETORT STACK</b>      | Three evaporating pans, 9 furnace bars, 3 dead plates, 3 bearing bars, 3 furnace frames with double doors, 12 shield tiles for furnace doors, 27 sight boxes and covers, 12 pilasters, 6 tie bolts, 1 girder bar, 2 dwarf pilasters, 4 holding plates and 12 bolts, 3 damper fire tiles with wrought iron rods, 5 cast iron $\square$ shaped Retorts, each 7 feet long $\times$ 14-in. wide $\times$ 12 in. deep inside measures, 5 mouthpieces and 10 covers for ditto; 30 $\frac{1}{2}$ -in. bolts for mouthpieces; 10 clay retorts, $\square$ shaped, each 7 ft. long $\times$ 17 in. wide $\times$ 13 in. deep inside measures, 10 mouthpieces and 20 covers for ditto; 60 $\frac{1}{2}$ -in. T headed bolts for mouthpieces; 15 pairs of wrought iron ears, 15 cross-bars, and 15 square-threaded T screws; 15 saddle flange pipes and bolts; 15 4-in. ascension pipes; 15 4-in. N pipes with cleaning plugs, 15 4-in. dip pipes and bolts; 1 Hydraulic Main, 14-in. diameter, and of sufficient length to receive the dip pipes from all the Retorts with ends and bolts; 4 crutched pillars to support Hydraulic Main. |
| <b>CONDENSER</b>         | One AIR CONDENSER, consisting of 1 bottom box fitted with cleaning doors, 20 5-in. pipes each 9 ft. long, 5 5-in. arch pipes with 2 cleaning plugs to each, 2 dip cisterns 16 in. $\times$ 16 in. $\times$ 21 in. deep, 2 5-in. T pipes and bolts for inlet and outlet.                                                                                                                                                                                                                                                                                                                                                                                                                                                                                                                                                                                                                                                                                                                                                                                                                                                       |
| <b>SCRUBBER</b>          | One SCRUBBER, 3 ft. diameter $\times$ 9 ft. high, fitted with 2 tiers of cast iron grids, 3 filling and discharging doors and frames, with cross-bars, T screws and bolts, 1 water distributor, with 1 in. main cock, kev, and syphon pipe; 1 cap and 1 base plate; 2 dip cisterns 16 in. $\times$ 16 in. $\times$ 21 in. deep, 2 5-in. T pipes and bolts for inlet and outlet; 1 5-in. fourway rising plug valve for by-passing Scrubber.                                                                                                                                                                                                                                                                                                                                                                                                                                                                                                                                                                                                                                                                                    |
| <b>PURIFIERS</b>         | Four dry lime PURIFIERS, each 5 ft. $\times$ 4 ft. $\times$ 2 ft. 6 in. deep, fitted with 4 tiers of sieves or grids, resting on ledges cast on the sides of purifiers, and on wrought iron T bearers, water lutes with wrought iron turn-buckles, wrought iron covers with ground air plugs and frames, and hooks for lifting; 4 covers for inlet pipes; 2 lifting carriages and chain slings for removing and replacing covers; 1 5-in. centre change valve for passing the gas through any three of the purifiers in succession, or through all four purifiers in succession.                                                                                                                                                                                                                                                                                                                                                                                                                                                                                                                                              |
| <b>STATION METER</b>     | One STATION METER, capable of registering 1,500 cubic feet of gas per hour, fitted with water gauge, filling plug, etc.; 1 5-in. fourway, by-pass, and shut-off rising plug valve, to act as by-pass to Station Meter, and stop valve to inlet of gasholder.                                                                                                                                                                                                                                                                                                                                                                                                                                                                                                                                                                                                                                                                                                                                                                                                                                                                  |
| <b>GASHOLDER</b>         | One GASHOLDER, 45 feet diameter $\times$ 14 feet deep at the sides, containing 22,000 cubic feet of gas; the sheets forming the crown and sides to be of No. 15 Birmingham wire gauge thickness, excepting the top and bottom rows, which are to be of No. 14 B. w. g., with strong and suitable internal frame-work; 6 cast-iron Guide columns each 15 feet high; 6 trussed wrought iron girders and bolts to connect the tops of columns; 18 foundation bolts and 6 foundation plates; 6 guide pulleys, with carriages, adjusting plates, axles, and bolts for top of sides, and 12 guide rollers with carriages, axles, and bolts for bottom of sides of Gasholder; 6 caps for tops of columns.                                                                                                                                                                                                                                                                                                                                                                                                                            |
| <b>GOVERNOR</b>          | One STATION GOVERNOR, fitted complete; 1 5-in. fourway, by-pass, and shut-off rising plug valve to act as by-pass to Governor, and as stop valve to outlet of Gasholder.                                                                                                                                                                                                                                                                                                                                                                                                                                                                                                                                                                                                                                                                                                                                                                                                                                                                                                                                                      |
| <b>CONNECTIONS, ETC.</b> | All the necessary 5-in. connecting pipes, not exceeding 100 yards, with bends and T pieces for connecting the Hydraulic Main, condenser, scrubber, purifiers, station meter, gasholder and governor, also 30 yards of 3-in. pipe with bends and T pieces for connecting the tar dip cisterns and from thence to tar well; 2 5-in. tank syphon boxes, 2 $\frac{1}{2}$ -in. wrought iron suction pipes.                                                                                                                                                                                                                                                                                                                                                                                                                                                                                                                                                                                                                                                                                                                         |
| <b>SUNDRIES</b>          | One 2 $\frac{1}{2}$ -in. lift and force pump for water, with bolts and plates for fixing to wall, 1 $\frac{1}{2}$ -in. suction and 1-in. delivery pipe with bends and connections; 1 wrought iron cistern to contain 100 gallons; 1 1-in. supply pipe and connections from cistern to scrubber; 1 1-in. supply pipe and connections from cisterns to retort house, with $\frac{1}{2}$ -in. draw off cock and key. 1 3 $\frac{1}{2}$ -in. tar pump, with wrought iron clip for securing to wall, 1 swivel joint, 1 $\frac{1}{2}$ -in. suction pipe, chain and shackle, 1 10-in. drain grate and frame; 2 pressure gauges and 1 test cock on boards, with service pipes, bends and tees.                                                                                                                                                                                                                                                                                                                                                                                                                                        |
| <b>TOOLS</b>             | One set of stoking tools, 1 firing shovel, 1 charging shovel, 1 iron coke barrow, 1 galvanized iron pail, 1 2-gallon water pot, 1 pair of sight hole tongs, 1 auger for ascension pipes, 1 trowel, 1 coal hammer, 1 retort lid scraper, 2 lime sieves, 1 lime shovel, 1 brass syphon pump. To provide all bolts, pins, rivets, cement, lead, yarn, red and white lead, paint and oil, required to fix the above, and to give the whole one coat of metallic oxide paint after completion.                                                                                                                                                                                                                                                                                                                                                                                                                                                                                                                                                                                                                                     |

45 tons.

Total dead weight of Ironwork.  
Measurement in cubic feet additional

Export Price delivered at the Docks in London, Liverpool, or Hull, inclusive of packing and Cases.

Home Price delivered at St. Neots Station, and erected complete in England, exclusive of buildings, foundations, brick or woodwork, or scaffolding.

Quantity of Firebricks, etc., required to set Retorts.

5750 square and 850 arch bricks, 8 lumps 26 in.  $\times$  12 in.  $\times$  6 in., 16 lumps 10 in.  $\times$  9 in.  $\times$  6 in., 16 lumps 8 in.  $\times$  5 in.  $\times$  4 in.  $\times$  6 in., 8 pairs of flue lumps, 8 lumps 11 in.  $\times$  6 in.  $\times$  7 in.  $\times$  5 thick, 27 tiles 18 in.  $\times$  12 in.  $\times$  3 in., 10 tiles 22 in.  $\times$  18 in.  $\times$  3 in., 7 tiles 17 in.  $\times$  12 in.  $\times$  3 in., 14 tiles 17 in.  $\times$  12 in.  $\times$  2 $\frac{1}{2}$  in., and 70 cwt. of fireclay.

27 tons 10 cwt.

Weight of Firebricks, etc.  
Price of Firebricks, etc., delivered at the Docks in London, Liverpool, or Hull.

## SPECIFICATIONS OF APPARATUS FOR VILLAGES, TOWNS, AND CITIES—continued.

| <i>No. 8b Apparatus</i>                                                                                                                                                                                                                                                                                                                                                                                                                                                                                         |                                                                                                                                                                                                                                                                                                                                                                                                                                                                                                                                                                                                                                                                                                                                                                                                                                                                                                                                     |
|-----------------------------------------------------------------------------------------------------------------------------------------------------------------------------------------------------------------------------------------------------------------------------------------------------------------------------------------------------------------------------------------------------------------------------------------------------------------------------------------------------------------|-------------------------------------------------------------------------------------------------------------------------------------------------------------------------------------------------------------------------------------------------------------------------------------------------------------------------------------------------------------------------------------------------------------------------------------------------------------------------------------------------------------------------------------------------------------------------------------------------------------------------------------------------------------------------------------------------------------------------------------------------------------------------------------------------------------------------------------------------------------------------------------------------------------------------------------|
| <i>For the manufacture and supply of 6,000,000 cubic feet of coal gas per annum.</i>                                                                                                                                                                                                                                                                                                                                                                                                                            |                                                                                                                                                                                                                                                                                                                                                                                                                                                                                                                                                                                                                                                                                                                                                                                                                                                                                                                                     |
| RETORT STACK                                                                                                                                                                                                                                                                                                                                                                                                                                                                                                    | Four evaporating pans, 12 furnace bars, 4 dead plates, 4 bearing bars, 4 furnace frames with double doors, 16 shield tiles for furnace doors, 28 sight boxes and covers, 14 pilasters, 7 tie bolts, 8 holding plates for furnace door frames and 16 bolts, 4 damper tiles with wrought iron rods. 20 fire clay $\square$ shaped Retorts each 7 ft. 6 in. long $\times$ 17 in. wide $\times$ 13 in. deep, inside measures, 20 mouthpieces and 40 covers for ditto; 120 $\frac{3}{4}$ -in. T headed bolts for mouthpieces; 20 pairs of wrought iron ears, 20 cross-bars, and 20 square-threaded T screws; 20 5-in. saddle flange pipes and bolts; 20 5-in. to 4-in. ascension pipes; 20 4-in. N pipes with cleaning plugs, 20 4-in. dip pipes and bolts, 1 Hydraulic Main, 14 in. diameter and of sufficient length to receive the dip pipes from all the Retorts, with ends and bolts; 5 crutched pillars to support Hydraulic Main. |
| CONDENSER                                                                                                                                                                                                                                                                                                                                                                                                                                                                                                       | One AIR CONDENSER, consisting of 1 bottom box fitted with cleaning doors, 20 6-in. pipes each 9 feet long, 5 6-in. arch pipes with 2 cleaning plugs to each, 2 dip cisterns each 16 in. $\times$ 16 in. $\times$ 21 in. deep, 2 5-in. T pipes and bolts for inlet and outlet.                                                                                                                                                                                                                                                                                                                                                                                                                                                                                                                                                                                                                                                       |
| SCRUBBER                                                                                                                                                                                                                                                                                                                                                                                                                                                                                                        | One SCRUBBER 3 ft. diameter $\times$ 9 ft. high, fitted with 2 tiers of cast iron grids, 3 filling and discharging doors and frames, with cross-bars, T screws and bolts; 1 water distributor with 1-in. main cock, key and syphon pipe; 1 cap and 1 base plate, 2 dip cisterns 16 in. $\times$ 16 in. $\times$ 21 in. deep, 2 5-in. T pipes and bolts for inlet and outlet; 1 5-in. fourway rising plug valve for by-passing scrubber.                                                                                                                                                                                                                                                                                                                                                                                                                                                                                             |
| EXHAUSTER                                                                                                                                                                                                                                                                                                                                                                                                                                                                                                       | One EXHAUSTING APPARATUS in duplicate, each part to be capable of passing 2,000 cubic feet of gas per hour, with steam engines, boilers, gearing, framework, fittings, steam and exhaust pipes, feed pumps and pipes, fly-wheels, shafts, plummer blocks, governors, throttle valves and stop valves complete; the exhausters, engines and boilers to be so arranged that either exhauster, engine or boiler can be shut off, or either exhauster can be worked by either engine as required. One governor with gearing and valve placed on the gas supply pipe, 1 self-acting by-pass valve, 1 5-in. fourway rising plug valve for by-passing the exhausting apparatus.                                                                                                                                                                                                                                                            |
| PURIFIERS                                                                                                                                                                                                                                                                                                                                                                                                                                                                                                       | Four dry lime PURIFIERS, each 8 ft. 6 in. $\times$ 3 ft. $\times$ 2 ft. 6 in. deep, and fitted with 4 tiers of sieves or grids, resting on ledges cast on the sides of purifiers, and on wrought iron T bearers, water lutes with wrought iron turn-buckles, wrought iron covers with ground air plugs and frames, and hooks for lifting; 8 covers for inlet pipes; 2 lifting carriages and chain slings for removing and replacing covers; 1 5-in. centre change valve for passing the gas through any three of the Purifiers in succession, or through all four Purifiers in succession.                                                                                                                                                                                                                                                                                                                                          |
| STATION METER                                                                                                                                                                                                                                                                                                                                                                                                                                                                                                   | One STATION METER, capable of registering 2000 cubic feet of gas per hour, fitted with water gauge, filling plug, etc.; 1 $\frac{5}{8}$ -in. fourway, by-pass, and shut-off rising plug valve, to act as by-pass to Station Meter, and stop valve to inlet of Gasholder.                                                                                                                                                                                                                                                                                                                                                                                                                                                                                                                                                                                                                                                            |
| GASHOLDER                                                                                                                                                                                                                                                                                                                                                                                                                                                                                                       | One GASHOLDER, 50 feet diameter $\times$ 15 feet deep at the sides, containing 30,000 cubic feet of gas; the sheets forming the crown to be of No. 15 Birmingham wire gauge thickness, the sheets forming the sides to be of No. 16 Birmingham wire gauge thickness, excepting the top and rows, which are to be of No. 14 Birmingham wire gauge thickness; to have strong and suitable internal framework. 6 cast iron Guide columns each 16 feet high; 6 trussed wrought iron girders and bolts to connect the tops of columns; 18 foundation bolts and 6 foundation plates; 6 guide pulleys with carriages, adjusting plates, axles and bolts for top of sides, and 12 guide rollers with carriages, axles, and bolts for bottom of sides of Gasholder, 6 caps for top of columns.                                                                                                                                               |
| GOVERNOR                                                                                                                                                                                                                                                                                                                                                                                                                                                                                                        | One STATION GOVERNOR, fitted complete; 1 6-in. fourway, by-pass, and shut-off rising plug valve to act as by-pass to governor, and as stop valve to outlet of Gasholder.                                                                                                                                                                                                                                                                                                                                                                                                                                                                                                                                                                                                                                                                                                                                                            |
| CONNECTIONS, ETC.                                                                                                                                                                                                                                                                                                                                                                                                                                                                                               | All the necessary 5-in. pipe, not exceeding 70 yards, with bends and T pieces for connecting the Hydraulic Main, condenser, scrubber, exhauster, purifiers, station meter and gasholder, and 40 yds. of 6-in. pipe with bends and T pieces for connecting the tar dip cisterns, and from thence to tar well; 1 5-in. and 1 4-in. tank syphon boxes, 2 $\frac{3}{4}$ -in. wrought iron suction pipes.                                                                                                                                                                                                                                                                                                                                                                                                                                                                                                                                |
| SUNDRIES                                                                                                                                                                                                                                                                                                                                                                                                                                                                                                        | One $2\frac{1}{2}$ -in. lift and force pump for water with gearing and framework for working by hand or by power; suction and delivery pipe to cistern with bends and connections; 1 cast iron cistern to contain 200 gallons; 1 1-in. supply pipe and connections from cistern to scrubber, and retort house, 1 $\frac{3}{4}$ -in. draw-off cock and key, 1 supply pipe and cock with bends and connections from cistern to feed pumps, 1 supply pipe with connections and draw-off cock for purifying house. 1 $3\frac{1}{2}$ -in. tar pump, with gearing and framework for working by hand or by power, suction pipe, swivel joint, chain, and shackle; 1 10-in. drain grate and frame. 3 pressure gauges and 1 test cock on boards, with service pipes, bends, and connections.                                                                                                                                                 |
| TOOLS                                                                                                                                                                                                                                                                                                                                                                                                                                                                                                           | One set of stoking tools, 1 firing shovel, 1 charging shovel, 1 coke barrow, 2 galvanized iron pails, 2 2-gal. water pots, 1 pair of sight hole tongs, 1 auger for ascension pipes, 1 trowel, 1 coal hammer, 1 retort lid scraper, 2 lime sieves, 1 lime shovel, 1 brass syphon pump. All bolts, pins, rivets, cement, lead, yarn, red and white lead, paint and oil, requisite to fix the above, and to give the whole one coat of metallic oxide paint after completion.                                                                                                                                                                                                                                                                                                                                                                                                                                                          |
|                                                                                                                                                                                                                                                                                                                                                                                                                                                                                                                 | 61 tons.                                                                                                                                                                                                                                                                                                                                                                                                                                                                                                                                                                                                                                                                                                                                                                                                                                                                                                                            |
| Total dead weight of Ironwork.<br>Measurement in cubic feet additional.<br>Export Price delivered at the Docks in London, Liverpool or Hull, inclusive of packing Cases.<br>Home Price, delivered at St. Neots Station, and erected complete in England, exclusive of buildings, foundations, brickwork or woodwork, or scaffolding.<br>Quantity of Firebricks, etc., required to set Retorts.<br>Weight of Firebricks, etc.<br>Price of Firebricks, etc., delivered at the Docks in London, Liverpool or Hull. | 8,000 square and 1,100 arch bricks, 16 lumps, 26 in. $\times$ 12 in. $\times$ 6 in., 32 lumps 10 in. $\times$ 9 in. $\times$ 6 in., 32 lumps 8 in. $\times$ 5 in. $\times$ 4 in. $\times$ 6 in., 36 tiles 18 in. $\times$ 12 in. $\times$ 3 in., and 5 tons of fireclay.<br>34 $\frac{1}{2}$ tons.                                                                                                                                                                                                                                                                                                                                                                                                                                                                                                                                                                                                                                  |

SPECIFICATIONS OF APPARATUS FOR VILLAGES, TOWNS, AND CITIES—continued.

No. 9b Apparatus.  
For the manufacture and supply of 9,000,000 cubic feet of coal gas per annum.

|                   |                                                                                                                                                                                                                                                                                                                                                                                                                                                                                                                                                                                                                                                                                                                                                                                                                                                                                                                                               |
|-------------------|-----------------------------------------------------------------------------------------------------------------------------------------------------------------------------------------------------------------------------------------------------------------------------------------------------------------------------------------------------------------------------------------------------------------------------------------------------------------------------------------------------------------------------------------------------------------------------------------------------------------------------------------------------------------------------------------------------------------------------------------------------------------------------------------------------------------------------------------------------------------------------------------------------------------------------------------------|
| RETORT STACK      | Five evaporating pans, 15 furnace bars, 5 dead plates, 5 bearing bars, 5 furnace frames with double doors, 20 shield tiles for furnace doors, 35 sight boxes and covers, 16 pilasters, 8 tie bolts, 10 holding plates for furnace doors frames and 20 bolts, 5 damper tiles with wrought iron rods. 25 fire clay $\square$ shaped Retorts each 8 ft. long $\times$ 17 in. wide $\times$ 13 in. deep inside measures, 25 mouthpieces and 50 covers for ditto; 150 $\frac{1}{2}$ -in. T headed bolts for mouthpieces; 25 pairs of wrought iron ears, 25 cross-bars, and 25 square-threaded T screws; 25 5-in. saddle flange pipes and bolts; 25 ascension pipes, 5-in. to 4-in. bore; 25 4-in. N pipes with cleaning plugs, 25 4-in. dip pipes and bolts; 1 Hydraulic Main, 16-in. diameter of bore, and of sufficient length to receive the dip pipes from all the Retorts, with ends and bolts; 6 crutched pillars to support Hydraulic Main. |
| CONDENSER         | One AIR CONDENSER, consisting of 1 bottom box, fitted with cleaning doors, 20 8-in. pipes each 9 ft. long, 5 8-in. arch pipes with 2 cleaning plugs to each, 2 dip cisterns each 16 in. $\times$ 16 in. $\times$ 21 in. deep, 2 6-in. T pipes and bolts for inlet and outlet.                                                                                                                                                                                                                                                                                                                                                                                                                                                                                                                                                                                                                                                                 |
| SCRUBBER          | One SCRUBBER, 3 ft. diameter $\times$ 12 ft. high, fitted with 2 tires of cast iron grids, 3 filling and discharging doors and frames, with cross-bars, T screws and bolts; 1 water distributor with 1 in. main cock, key and syphon pipe; 1 cap and 1 base plate, 2 dip cisterns 16 in. $\times$ 16 in. $\times$ 21 in. deep, 2 6-in. T pipes and bolts for inlet and outlet; 1 6-in. fourway rising plug valve for by-passing scrubber.                                                                                                                                                                                                                                                                                                                                                                                                                                                                                                     |
| EXHAUSTER         | One EXHAUSTING APPARATUS in duplicate, each part to be capable of passing 3000 cubic feet of gas per hour, with steam engines, boilers, gearing, framework, fittings, steam and exhaust pipes, feed pumps and pipes, fly-wheels, shafts, plumber blocks, governors, throttle valves and stop valves complete; the exhausters, engines and boilers to be so arranged that either exhauster, engine or boiler can be shut off, or either exhauster can be worked by either engine as required. One governor with gearing and valve placed on the gas supply pipe, 1 self-acting by-pass valve, 1 6-in. six-way rising plug valve, arranged to pass the gas through both exhausters at once, and to by-pass one or both exhausters.                                                                                                                                                                                                              |
| PURIFIERS         | Four dry lime PURIFIERS, each 6 ft. $\times$ 6 ft. $\times$ 3 ft. deep, and fitted with 4 tiers of wood sieves or grids, resting on ledges cast on the sides of purifiers, and on wrought iron T bearers, water lutes with wrought iron turn-buckles, wrought iron covers with ground air plugs and frames, and hooks for lifting; 4 covers for inlet pipes; 2 lifting carriages and chain slings for removing and replacing covers; 1 6-in. centre change valve for passing the gas through any three of the purifiers in succession, or through all four purifiers in succession.                                                                                                                                                                                                                                                                                                                                                           |
| STATION METER     | One STATION METER, capable of registering 3000 cubic ft. of gas per hour, fitted with water gauge, filling plug, etc.; 1 6-in. fourway, by-pass, and shut-off rising plug valve, to act as by-pass to Station Meter, and as stop valve to inlet of Gasholder.                                                                                                                                                                                                                                                                                                                                                                                                                                                                                                                                                                                                                                                                                 |
| GASHOLDER         | One GASHOLDER, 60 ft. diameter $\times$ 16 ft. deep at the sides, containing 45,000 cubic ft. of gas; the sheets forming the crown to be of No. 14 Birmingham wire gauge thickness, the sheets forming the sides to be 15 Birmingham wire gauge thickness, excepting the top and bottom rows which are to be of No. 14 Birmingham wire gauge thickness; to have strong and suitable internal framework. 6 cast iron Guide Columns, each 17 ft. high; 6 wrought iron lattice girders, with cast iron sockets and bolts for securing to tops of columns; 6 tops or caps for columns and bolts; 18 foundation bolts and 6 foundation plates; 6 guide pulleys with carriages, adjusting plates, axles and bolts for top of sides, and 12 guide rollers with carriages, axles and bolts for bottom of sides of Gasholder.                                                                                                                          |
| GOVERNOR          | One STATION GOVERNOR, fitted complete; 1 8-in. fourway, by-pass, and shut-off rising plug valve to act as by-pass to Governor, and as stop valve to outlet of gasholder.                                                                                                                                                                                                                                                                                                                                                                                                                                                                                                                                                                                                                                                                                                                                                                      |
| CONNECTIONS, ETC. | All the necessary 6 in. pipe, not exceeding 80 yds., with bends and T pieces for connecting the Hydraulic Main, condenser, scrubber, exhauster, purifiers, station meter, and gasholder, and 50 yards of 8 in. pipe with bends and T pieces to connect the gasholder and governor, also 40 yards of 4 in. pipe with bends and T pieces for connecting the tar dip cisterns, and from thence to tar well; 1 6-in. and 1 8-in. tank syphon boxes, 2 $\frac{1}{2}$ -in. wrought iron suction pipes.                                                                                                                                                                                                                                                                                                                                                                                                                                              |
| SUNDRIES          | One 2 $\frac{1}{2}$ -in. lift and force pump for water, with gearing and framework for working by hand or by power; suction and delivery pipe to cistern with bends and connections; 1 wrought iron cistern to contain 200 gallons; supply pipes and connections from cisterns to retort house, purifier house, and scrubber, with 2 draw-off cocks, one supply pipe and cock with bends and connections from cistern to feed pumps. One 3 $\frac{1}{2}$ -in. tar pump, with framework and gearing for working by hand or by power, suction pipe, swivel joint, chain and shackle, 1 10-in. drain grate and frame. 3 pressure gauges and 1 testcock on boards, with service pipes, bends, and connections.                                                                                                                                                                                                                                    |
| TOOLS             | One set of stoking tools, 1 firing shovel, 2 charging shovels, 1 iron coke barrow, 1 wood coal barrow, 2 galvanized iron pails, 2 2-gallon water pots, 1 pair of sight hole tongs, 1 auger for ascension pipes, 1 trowel, 1 coal hammer, 1 retort lid scraper, 2 lime sieves, 1 lime shovel, 1 weighing machine for coal and coke, 1 brass syphon pump. To provide all bolts, pins, rivets, cement, lead, yarn, red and white lead, paint and oil, requisite to fix the above, and to give the whole one coat of metallic oxide paint after completion.                                                                                                                                                                                                                                                                                                                                                                                       |

87 tons.

Total dead weight of ironwork  
Measurement in cubic feet additional.  
Export Price delivered at the Docks in  
London, Liverpool, or Hull, inclusive  
of packing and Cases.  
Home Price delivered at St. Neots  
Station, and erected complete in  
England, exclusive of buildings, founda-  
tions, brick or woodwork, or scaf-  
olding.  
Quantity of Firebricks, etc., re-  
quired to set Retorts.  
Weight of Firebricks, etc.  
Price of Firebricks, etc., delivered at  
the docks in London, Liverpool, or  
Hull.

10,500 square and 1,500 arch bricks, 20 lumps 26 in.  $\times$  12 in.  $\times$  6 in., 40 lumps 10 in.  $\times$  9 in.  $\times$  6 in.,  
40 lumps 8 in.  $\times$  5 in.  $\times$  4 in.  $\times$  6 in., 45 tiles 18 in.  $\times$  12 in.  $\times$  3 in., and 125 cwt. of fireclay.  
45 tons.

SPECIFICATIONS OF APPARATUS FOR VILLAGES, TOWNS AND CITIES—continued.

No. 106 Apparatus  
For the manufacture and supply of 12,000,000 cubic feet of coal gas per annum.

**RETORT STACK**

Four evaporating pans, 12 furnace bars, 4 dead plates, 4 bearing bars, 4 furnace frames with double doors, 16 shield tiles for furnace doors, 40 sight boxes and covers, 14 pilasters, 7 tie bolts, 8 holding plates for furnace doors and frames and 16 bolts, 4 damper tiles with wrought iron rods. 28 fire clay  $\square$  shaped Retorts each 8 ft. long  $\times$  17 in. wide  $\times$  13 in. deep inside measures, 28 mouthpieces and 45 covers for ditto; 168  $\frac{1}{2}$ -in. T headed bolts for mouthpieces; 28 pairs of wrought iron ears, 28 cross bars, and 28 square-threaded T screws; 28 5-in. saddle flange pipes and bolts; 28 ascension pipes, 5 in. to 4 in. bore; 28 4-in. N pipes with cleaning plugs, 28 4-in. dip pipes and bolts; 1 Hydraulic Main, 16 in. diameter of bore, and of sufficient length to receive the dip pipes from all the Retorts, with ends and bolts; 5 crutched pillars to support Hydraulic Main.

**CONDENSER**

One AIR CONDENSER, on the Annular principle, consisting of 6 outer tubes each of 21 in. external diameter and 12 feet high, and having a flange at each end, and 6 inner tubes each of 12 in. external diameter and 15 ft. high with flange at each end; 1 top box in 3 parts and 1 bottom box in 4 parts with cleaning doors and bolts; 4 3-in. T pipes with cleaning caps and bolts, 1 6-in. T pipe with cleaning cap and bolts for inlet to Condenser, 1 6-in. bend with cleaning cap and bolts for outlet from Condenser, 2 dip cisterns 16 in.  $\times$  16 in.  $\times$  21 deep, each internal tube to be provided with a damper plate for controlling the current of air.

**SCRUBBER**

One Coke or Breeze SCRUBBER, 3 ft. 6 in. diameter  $\times$  12 ft. high, fitted with 2 tiers of cast iron grids, 3 filling and discharging doors and frames, 4 wrought iron T bearers for supporting grids, wrought iron gearing for filling and discharging doors, 1 water distributor with main cock, key, and syphon pipe; 1 cap and 1 base plate, 2 dip cisterns 16 in.  $\times$  16 in.  $\times$  21 in. deep, 2 6-in. T pipes with cleaning caps and bolts for inlet and outlet; 1 6-in. fourway rising plug valve for by-passing scrubber.

**EXHAUSTER**

One EXHAUSTING APPARATUS in duplicate, each part to be capable of passing 4,000 cubic feet of gas per hour, with steam engines, boilers, gearing, framework, fittings, steam and exhaust pipes, feed pumps and pipes, fly-wheels, shafts, plumber blocks, governors, throttle valves and stop valves, complete; the exhausters, engines and boilers to be so arranged that either exhauster, engine or boiler can be shut off, or either exhauster can be worked by either engine as required. One governor with gearing and valve placed on the gas supply pipe, 1 self-acting by-pass valve, 1 6-in. six-way rising plug valve, arranged to pass the gas through both exhausters at once, or to by-pass one or both exhausters.

**PURIFIERS**

Four dry lime PURIFIERS, each 6 ft.  $\times$  6 ft.  $\times$  3 ft. deep, and fitted with 4 tiers of wood sieves or grids, resting on ledges cast on the sides of purifiers, and on wrought-iron T bearers, water lutes with wrought-iron turn-buckles, wrought-iron covers with ground air plugs and frame, and hooks for lifting; 4 covers for inlet pipes; 2 lifting carriages and chain slings for removing and replacing covers; 1 6-in. centre change valve for passing the gas through any three of the purifiers in succession, or through all four purifiers in succession.

**STATION METER**

One STATION METER, capable of registering 4000 cubic ft. of gas per hour, fitted with water gauge, filling plug, &c.; 1 6-in. fourway, by-pass, and shut-off rising plug valve, to act as by-pass to station meter, and as stop valve to inlet of Gasholder.

**GASHOLDER**

One GASHOLDER, 65 ft. diameter  $\times$  18 ft. deep at the sides, containing 60,000 cubic ft. of gas: the sheets forming the crown to be of No. 14 Birmingham wire gauge thickness, excepting the outer row which is to be of No. 12 Birmingham wire gauge thickness, the sheets forming the sides to be of No. 13 Birmingham wire gauge thickness, excepting the top and bottom rows which are to be of No. 13 Birmingham wire gauge thickness; to have strong and suitable internal framework. 7 cast iron guide columns each 19 feet high; 7 wrought iron lattice girders, with cast iron sockets and bolts for securing to tops of columns; 7 tops or caps for columns and bolts; 21 foundation bolts and 7 foundation plates; 7 guide pulleys with carriages, adjusting plates, axles and bolts for top of sides, and 14 guide rollers with carriages, axles, and bolts for bottom of sides of Gasholder.

**GOVERNOR**

One STATION GOVERNOR, fitted complete: 1 8-in. fourway, by-pass, and shut-off rising plug valve to act as by-pass to governor, and as stop valve to outlet of Gasholder.

**CONNECTIONS, ETC.**

All the necessary 6-in. pipe, not exceeding 80 yds. with bends and T pieces, for connecting the Hydraulic Main, condenser, scrubber, exhauster, purifier, station meter, and gasholder, and 50 yards of 8-in. pipe with bends and T pieces to connect the gasholder and governor, also 40 yards of 3-in. pipe with bends and T pieces for connecting the tar dip cisterns and from thence to tar well; 1 6-in. and 1 8-in. tank syphon boxes, 2  $\frac{1}{2}$ -in. wrought iron suction pipes.

**SUNDRIES**

One 2 $\frac{1}{2}$ -in. lift and force pump for water, with gearing and framework for working by hand or by power; suction and delivery pipe to cistern with bends and connections; 1 wrought iron cistern to contain 300 galls.; supply pipes and connections from cistern to retort house, purifier house, and scrubber, with 2 draw-off cocks; one supply pipe and cock with bends and connections, and 6 feed pipes from cistern to condenser; one supply pipe and cocks with bends and connections from cistern to feed pumps. One 4-in. tar pump, with framework and gearing for working by hand or by power, suction pipe, swivel joint, chain, and shackle, 1 10-in. drain grate and frame. 3 pressure gauges and 1 test cock on boards with service pipes, bends and connections. To provide the necessary pipe and fittings for gas-lights in retort house, yard, engine and boiler house and offices.

**TOOLS**

Two sets of stoking tools, 1 firing shovel, 4 charging shovels, 1 iron coke waggon, 1 coal waggon, 1 weighing machine and weights for coal and coke, 2 galvanised iron pails, 2 2-gallon water pots, 2 pairs of sight hole tongs, 2 augers for ascension pipes, 2 trowels, 2 coal hammers, 2 retort lid scrapers, 2 lime sieves, 2 lime shovels, 1 2-gallon water pot for purifier house, 1 brass syphon pump. To provide all bolts, pins, rivets, cement, lead, yarn, red and white lead, paint and oil, requisite to fix the above, and to give the whole one coat of metallic oxide paint after completion.

Total Dead Weight of Ironwork.  
Measurement in cubic feet additional.  
Export Price delivered at the Docks in London, Liverpool, or Hull, inclusive of packing and Cases.  
Home Price delivered at St. Neots Station, and erected complete in England, exclusive of buildings, foundations, brick or woodwork, or scaffolding.  
Quantity of Firebricks, etc., required to set Retorts.

8800 square and 1600 arch bricks, 32 lumps 23 in.  $\times$  9 in.  $\times$  4 $\frac{1}{2}$  in. 32 lumps 9 in.  $\times$  9 in.  $\times$  4 $\frac{1}{2}$  in., 32 lumps 6 in.  $\times$  4 $\frac{1}{2}$  in.  $\times$  6 in.  $\times$  4 $\frac{1}{2}$  in., 32 lumps, 4 in.  $\times$  4 $\frac{1}{2}$  in.  $\times$  4 $\frac{1}{2}$  in., 16 lumps 10 in.  $\times$  6 in.  $\times$  4 $\frac{1}{2}$  in., 36 tiles 18 in.  $\times$  12 in.  $\times$  3 in., and 6 tons of fireclay.

Weight of Firebricks, etc.  
Price of Firebricks, etc., delivered at the Docks in London, Liverpool, or Hull.

43 $\frac{1}{2}$  tons

SPECIFICATIONS OF APPARATUS FOR VILLAGES, TOWNS, AND CITIES—continued.

No. 11b Apparatus  
For the manufacture and supply of 15,000,000 cubic feet of coal gas per annum.

|                   |                                                                                                                                                                                                                                                                                                                                                                                                                                                                                                                                                                                                                                                                                                                                                                                                                                                                                                                                              |
|-------------------|----------------------------------------------------------------------------------------------------------------------------------------------------------------------------------------------------------------------------------------------------------------------------------------------------------------------------------------------------------------------------------------------------------------------------------------------------------------------------------------------------------------------------------------------------------------------------------------------------------------------------------------------------------------------------------------------------------------------------------------------------------------------------------------------------------------------------------------------------------------------------------------------------------------------------------------------|
| RETORT STACK      | Five evaporating pans, 15 furnace bars, 5 dead plates, 5 bearing bars, 5 furnace frames with double doors, 20 shield tiles for furnace doors, 50 sight boxes and covers, 16 pilasters, 8 tie bolts, 10 holding plates for furnace door frames and 20 bolts, 5 damper tiles, with wrought iron rods, 35 fire clay $\square$ shaped Retorts each 8 ft. long $\times$ 17 in. wide $\times$ 13 in. deep inside measures, 35 mouthpieces and 50 covers for ditto; 210 $\frac{3}{4}$ -in. T headed bolts for mouthpieces; 35 pairs of wrought iron ears, 35 cross-bars, and 35 square-threaded T screws; 35 5-in. saddle flange pipes and bolts; 35 ascension pipes; 5 in. to 4 in. bore; 35 4-in. N pipes with cleaning plugs, 35 4-in. dip pipes and bolts; 1 Hydraulic Main, 16 in. diameter of bore and of sufficient length to receive the dip pipes from all the Retorts, with ends and bolts; 6 crutched pillars to support Hydraulic Main. |
| CONDENSER         | One AIR CONDENSER on the Annular principle, consisting of 8 outer tubes each of 21-in. external diameter and 12 feet high, and having a flange at each end, and 8 inner tubes each of 12-in. external diameter and 15 feet high with flange at each end; 1 top box in 4 parts, and 1 bottom box in 5 parts with cleaning doors and bolts; 5 4-in. T pipes with cleaning caps and bolts, 1 8-in. T pipe with cleaning cap and bolts for inlet to condenser, 1 8-in. bend with cleaning cap and bolts for outlet from condenser, 2 dip cisterns each 18 in. $\times$ 18 in. $\times$ 21 in. deep, each internal tube to be provided with a damper for controlling the current of air.                                                                                                                                                                                                                                                          |
| SCRUBBERS         | Two Coke or Breeze SCRUBBERS, each 3 ft. 6 in. diameter $\times$ 12 ft. high, fitted with 2 tiers of cast iron grids, with wrought iron T bearers for supporting ditto, 3 filling and discharging doors and frames, with wrought iron ears, cross-bars, T screws and bolts, 1 water distributing apparatus with main cock and key; each scrubber to have also a base plate and cap, 2 8-in. T pipes with cleaning caps and bolts for inlet and outlet; 2 dip cisterns each 18 in. $\times$ 18 in. $\times$ 21 in. deep. To provide 1 8-in. sixway rising plug valve arranged to pass the gas through both scrubbers at once, or to by-pass one or both scrubbers as required.                                                                                                                                                                                                                                                                |
| EXHAUSTER         | One EXHAUSTING APPARATUS in duplicate, each part to be capable of passing 5,000 cubic feet of gas per hour, with steam engines, boilers, gearing, framework, fittings, steam and exhaust pipes, feed pumps and pipes, fly-wheels, shafts, plummer blocks, governors, throttle valves and stop valves complete; the exhausters, engines and boilers to be so arranged that either exhauster, engine or boiler can be shut off, or either exhauster can be worked by either engine as required. One governor with gearing and valve placed on the gas supply pipe, 1 self-acting by-pass valve, 1 8-in. six-way rising plug valve, arranged to pass the gas through both exhausters at once, or to by-pass one or both exhausters.                                                                                                                                                                                                             |
| PURIFIERS         | Four DRY LIME PURIFIERS, each 8 ft. $\times$ 8 ft. $\times$ 3 ft. deep, and fitted with 4 tiers of wood sieves or grids, resting on ledges cast on the side of purifiers, and on wrought iron T bearers, water lutes with wrought iron turn-buckles, wrought iron covers with ground air plugs and frames, and hooks for lifting; 4 covers for inlet pipes; 2 lifting carriages and chain slings for removing and replacing the covers of purifiers, 4 wrought iron lattice girders for carrying lifting carriages and covers. To provide 1 8-in. centre change valve for passing the gas through any three of the purifiers in succession, or through all four purifiers in succession as required.                                                                                                                                                                                                                                         |
| STATION METER     | One STATION METER, capable of registering 5,000 cubic feet of gas per hour, and fitted with pressure and water gauges, tell tale, indices, filling plug, etc. To provide 1 8-in. fourway, by-pass, and shut-off rising plug valve, to act as by-pass to station meter, and as stop valve to inlet of Gasholder.                                                                                                                                                                                                                                                                                                                                                                                                                                                                                                                                                                                                                              |
| GASHOLDER         | One GASHOLDER, 70 feet diameter $\times$ 20 ft. deep at the sides, containing 77,000 cubic feet of gas; the sheets forming the crown to be of No. 14 Birmingham wire gauge thickness, excepting the outer row which is to be of No. 12 Birmingham wire gauge thickness, the sheets forming the sides to be of No. 14 Birmingham wire gauge thickness, excepting the top and bottom rows which are to be of No. 12 Birmingham wire gauge thickness; to have strong and suitable internal framework. 7 cast iron guide columns, each 21 feet high; 7 wrought iron lattice girders, with cast iron sockets and bolts for securing to tops of columns; 7 tops or caps for columns and bolts; 21 foundation bolts and 7 foundation plates; 7 guide pulleys with carriages, adjusting plates, axles and bolts for top of sides, and 14 guide rollers with carriages, axles, and bolts for bottom of sides of Gasholder.                            |
| GOVERNOR          | One STATION GOVERNOR fitted complete; 1 10-in. fourway, by-pass, and shut-off rising plug valve to act as by-pass to governor, and as stop valve to outlet of Gasholder.                                                                                                                                                                                                                                                                                                                                                                                                                                                                                                                                                                                                                                                                                                                                                                     |
| CONNECTIONS, ETC. | All the necessary 8 in. pipe, not exceeding 100 yards, with bends and T pieces for connecting the Hydraulic Main, condenser, scrubber, exhauster, purifiers, station meter, and gasholder, and 60 yards of 10-in. pipe with bends and T pieces to connect the gasholder and governor, also 40 yards of 4-in. pipe with bends and T pieces for connecting the tar dip cisterns and from thence to tar well; 1 8-in. and 1 10-in. syphon boxes, 2 $\frac{3}{4}$ -in. wrought iron suction pipes.                                                                                                                                                                                                                                                                                                                                                                                                                                               |
| SUNDRIES          | One 3-in. lift and force pump for water, with gearing and framework for working by hand or by power; suction and delivery pipes to cistern with bends and connections; 1 wrought iron cistern to contain 300 gallons; water supply pipes and connections from cistern to retort house, purifier house, and scrubber, with 2 draw-off cocks; one supply pipe and cock with bends and connections, and 8 feed pipes from cistern to condenser; one supply pipe and cocks with bends and connections from cistern to feed pumps. One 4-in. tar pump, with framework and gearing for working by hand or by power, suction pipe, swivel joint, chain and shackle, 1 10-in. drain grate and frame. 5 pressure gauges and 2 test cocks on boards with services pipes, bends and connections. To provide the necessary pipe and fittings for gas-lights in retort house, yard, engine and boiler house and offices.                                  |
| TOOLS             | Two sets of stoking tools, 2 firing shovels, 4 charging shovels, 1 iron coke waggon, 1 coal waggon, 1 weighing machine and weights for coal and coke, 2 galvanized iron pails, 2 2-gallon water pots, 2 pairs of sight hole tongs, 2 augers for ascension pipes, 2 trowels, 2 coal hammers, 2 retort lid scrapers, 3 lime sieves, 3 lime shovels, 1 2-gallon water pot for purifier house, 1 brass syphon pump. To provide all bolts, pins, rivets, cement, lead, yarn, red and white lead, paint and oil, requisite to fix the above and to give the whole one coat of metallic oxide paint after completion.                                                                                                                                                                                                                                                                                                                               |

140 tons.

Total Dead Weight of Ironwork.  
Measurement in cubic feet additional.  
Export Price delivered at the Docks in London, Liverpool, or Hull, inclusive of packing and Cases.  
Home Price, delivered at St. Neots Station, and erected complete in England, exclusive of buildings, foundations, brickwork or woodwork, or scaffolding.  
Quantity of Firebricks, etc., required to set Retorts,

11,000 square and 2,000 arch bricks, 40 lumps 23 in.  $\times$  9 in.  $\times$   $4\frac{1}{2}$  in., 40 lumps 9 in.  $\times$  9 in.  $\times$   $4\frac{1}{2}$  in., 40 lumps 6 in.  $\times$   $4\frac{1}{2}$  in.  $\times$  6 in.  $\times$   $4\frac{1}{2}$  in., 40 lumps 4 in.  $\times$   $4\frac{1}{2}$  in.  $\times$   $4\frac{1}{2}$  in., 20 lumps 10 in.  $\times$  6 in.  $\times$   $4\frac{1}{2}$  in., 45 tiles 18 in.  $\times$  12 in.  $\times$  3 in., and  $7\frac{1}{2}$  tons of fireclay.

56 tons.

Weight of Firebricks, etc.  
Price of Firebricks, etc., delivered at the Docks in London, Liverpool or Hull.

## SPECIFICATIONS OF APPARATUS FOR VILLAGES, TOWNS AND CITIES—continued.

| <i>No. 12b Apparatus</i>                                                                                                                                                                                                                                                                                                                                                                                                                                                                                                        |                                                                                                                                                                                                                                                                                                                                                                                                                                                                                                                                                                                                                                                                                                                                                                                                                                                                                                                                                                                                                                                                                                                                                                                                                                                                                                                        |
|---------------------------------------------------------------------------------------------------------------------------------------------------------------------------------------------------------------------------------------------------------------------------------------------------------------------------------------------------------------------------------------------------------------------------------------------------------------------------------------------------------------------------------|------------------------------------------------------------------------------------------------------------------------------------------------------------------------------------------------------------------------------------------------------------------------------------------------------------------------------------------------------------------------------------------------------------------------------------------------------------------------------------------------------------------------------------------------------------------------------------------------------------------------------------------------------------------------------------------------------------------------------------------------------------------------------------------------------------------------------------------------------------------------------------------------------------------------------------------------------------------------------------------------------------------------------------------------------------------------------------------------------------------------------------------------------------------------------------------------------------------------------------------------------------------------------------------------------------------------|
| <i>For the manufacture and supply of 30,000,000 cubic feet of coal gas per annum.</i>                                                                                                                                                                                                                                                                                                                                                                                                                                           |                                                                                                                                                                                                                                                                                                                                                                                                                                                                                                                                                                                                                                                                                                                                                                                                                                                                                                                                                                                                                                                                                                                                                                                                                                                                                                                        |
| <b>RETORT STACK</b>                                                                                                                                                                                                                                                                                                                                                                                                                                                                                                             | Ten evaporating pans, 30 furnace bars, 10 dead plates, 10 bearing bars, 10 furnace frames with double doors, 40 shield tiles for furnace doors, 100 sight boxes and covers, 20 pilasters, 10 tie bolts, 20 holding plates for furnace door frames and 40 bolts, 10 damper tiles with wrought iron rods. 35 fire clay $\square$ shaped Retorts each 16 feet long by 17 in. wide by 13 in. deep inside measures, 70 mouthpieces and 100 covers for ditto; 420 $\frac{1}{2}$ -in. T headed bolts for mouthpieces; 70 pairs of wrought iron ears, 70 cross-bars, and 70 square-threaded T screws; 70 5-in. saddle flange pipes and bolts; 70 ascension pipes 5 in. to 4 in. bore; 70 4-in. N pipes with cleaning plugs; 70 4-in. dip pipes and bolts; 2 Hydraulic Mains each 16 in. diameter of bore, and of sufficient length to receive the dip pipes from 35 mouthpieces with ends and bolts, 1 10-in. pipe for connecting, and 12 crutched pillars to support the Hydraulic Mains.                                                                                                                                                                                                                                                                                                                                     |
| <b>CONDENSERS</b>                                                                                                                                                                                                                                                                                                                                                                                                                                                                                                               | One AIR CONDENSER, on the Annular principle, consisting of 12 outer tubes each of 21 in. external diameter and 12 ft. high, with flange at each end, and 12 inner tubes each of 12 in. external diameter and 15 ft. high with flange at each end; 2 top boxes each in 3 parts, and 2 bottom boxes each in 4 parts, with cleaning doors and bolts; 8 4-in. T pipes with cleaning caps and bolts, 2 10-in. T pipes with cleaning caps and bolts for inlet to condenser, 2 10-in. bends with cleaning caps and bolts for outlet from condenser, 2 dip cisterns each 18 in. by 18 in. by 21 in. deep; each internal tube to be provided with a damper plate for controlling the current of air. To provide 1 10-in. sixway rising plug valve; arranged for passing the gas through both divisions of condenser in succession, or for by-passing either division.                                                                                                                                                                                                                                                                                                                                                                                                                                                           |
| <b>SCRUBBERS</b>                                                                                                                                                                                                                                                                                                                                                                                                                                                                                                                | Two COKE OR BREEZE SCRUBBERS, each 5 ft. diameter by 12 ft. high, fitted with 2 tiers of cast iron grids, with wrought iron T bearers for supporting ditto, 3 filling and discharging doors and frames, with wrought iron ears, cross-bars, T screws and bolts; 1 water distributing apparatus with main cock and key; each scrubber to have also a base plate and cap, 2 10-in. T pipes with cleaning caps and bolts for inlet and outlet, and 2 dip cisterns each 18 in. by 18 in. by 21 in. deep. To provide 1 10-in. sixway rising plug valve arranged to pass the gas through both scrubbers at once, or to by-pass one or both scrubbers as required.                                                                                                                                                                                                                                                                                                                                                                                                                                                                                                                                                                                                                                                            |
| <b>EXHAUSTERS</b>                                                                                                                                                                                                                                                                                                                                                                                                                                                                                                               | One EXHAUSTING APPARATUS in duplicate, each part to be capable of passing 10,000 cubic feet of gas per hour, with steam engines, boilers, gearing, framework, fittings, steam and exhaust pipes, feed pumps and pipes, fly-wheels, shafts, plunger blocks, governors, throttle valves and stop valves complete; the exhausters, engines and boilers to be so arranged that either exhauster, engine or boiler can be shut off, or either exhauster can be worked by either engine as required. One governor with gearing and valve placed on the gas supply pipe, 1 self-acting by-pass valve, 1 10-in. sixway rising plug valve, arranged to pass the gas through both exhausters at once, or to by-pass either one or both exhausters.                                                                                                                                                                                                                                                                                                                                                                                                                                                                                                                                                                               |
| <b>PURIFIERS</b>                                                                                                                                                                                                                                                                                                                                                                                                                                                                                                                | Four dry lime PURIFIERS, each 10 ft. $\times$ 10 ft. $\times$ 3 ft. 6 in. deep, and fitted with 4 tiers of wood sieves or grids resting on ledges cast on the sides of purifiers, and on wrought-iron T bearers, water lutes with wrought-iron turn-buckles, wrought-iron covers with ground air plugs and frames, and books for lifting; 4 covers for inlet pipes; 2 lifting carriages and chain slings for removing and replacing covers of purifiers, 4 wrought iron lattice girders for carrying lifting carriages and covers. To provide 1 10-in. centre change valve for passing the gas through any three of the purifiers in succession, or through all four purifiers in succession as required.                                                                                                                                                                                                                                                                                                                                                                                                                                                                                                                                                                                                              |
| <b>STATION METER</b>                                                                                                                                                                                                                                                                                                                                                                                                                                                                                                            | One STATION METER, capable of registering 10,000 cubic ft. of gas per hour, fitted with pressure and water gauges, tell tale, indices, filling plug, etc. To provide 1 10-in. fourway, by-pass, and shut-off rising plug valve, to act as by-pass to station meter.                                                                                                                                                                                                                                                                                                                                                                                                                                                                                                                                                                                                                                                                                                                                                                                                                                                                                                                                                                                                                                                    |
| <b>GASHOLDER</b>                                                                                                                                                                                                                                                                                                                                                                                                                                                                                                                | Two GASHOLDERS, 70 ft. diameter by 20 ft. deep at the sides, and containing 77,000 cubic feet; the sheets forming the crowns to be of No. 14 Birmingham wire gauge thickness, excepting the outer rows of sheets, which are to be of No. 12 Birmingham wire gauge thickness; the sheets forming the sides to be of No. 14 Birmingham wire gauge thickness, excepting the top and bottom rows of sheets which are to be of No. 12 Birmingham wire gauge thickness; to have strong and suitable internal framework. To provide for each gas-holder, 7 cast iron guide columns each 21 feet high; 7 wrought iron lattice girders, with bolts and cast iron sockets for securing to tops of columns; 7 tops or caps for columns and bolts; 21 foundation bolts and 7 foundation plates; 7 guide pulleys with carriages, adjusting plates, axles and bolts for top of sides, and 14 guide rollers with carriages, axles, and bolts for bottom of sides of Gasholder.                                                                                                                                                                                                                                                                                                                                                        |
| <b>GOVERNORS</b>                                                                                                                                                                                                                                                                                                                                                                                                                                                                                                                | One STATION GOVERNOR, fitted complete: 1 12-in. fourway, by-pass, and shut-off rising plug valve to act as by-pass to governor.                                                                                                                                                                                                                                                                                                                                                                                                                                                                                                                                                                                                                                                                                                                                                                                                                                                                                                                                                                                                                                                                                                                                                                                        |
| <b>CONNECTIONS, ETC.</b>                                                                                                                                                                                                                                                                                                                                                                                                                                                                                                        | All the necessary 10-in. pipe, not exceeding 150 yds. with bends and T pieces, for connecting the Hydraulic Main, condensers, scrubbers, exhausters, purifiers, station meter, and gasholder, and 80 yards of 12-in. pipe with bends and T pieces for connecting both the gasholders and governor, also 50 yards of 4-in. pipe for connecting the tar dip cisterns and from thence to tar well; 2 10-in. and 2 12-in. tank syphons, 3 10-in. and 2 12-in. through way rising plug valves, for inlet and outlet to both gasholders, and by-pass; 4 $\frac{1}{2}$ -in. wrought iron suction pipes.                                                                                                                                                                                                                                                                                                                                                                                                                                                                                                                                                                                                                                                                                                                       |
| <b>SUNDRIES</b>                                                                                                                                                                                                                                                                                                                                                                                                                                                                                                                 | One set of gearing and framework, 2 3-in. lift and force pumps for water, arranged to be worked either by hand or by power, with suction and delivery pipes to cistern, bends and connections; 1 wrought iron cistern to contain 750 gallons; supply pipes and connections from cistern to retort house, purifier house, and scrubbers, with 6 draw-off cocks, and 2 brass main cocks for ditto; 1 supply pipe with bends and connections, and 2 brass main cocks, and 12 feed pipes from water cistern to condensers, 1 supply pipe with bends and connections, and 2 brass main cocks, from water cistern to feed pumps. To provide 1 set of gearing and framework, and 2 4-in. suction pumps, one for tar and one for ammoniacal liquor, arranged to be working either by hand or by power, with 3 in. pipe into tar well, 2 10-in. drain grates and frames. To provide for various parts of the apparatus, 7 pressure gauges with service pipes, bends and connections, 1 vacuum gauge with service pipe, bends, cocks and connections, for exhausters, 1 registering pressure gauge, with service pipe, bends and connections, 4 test cocks with service pipes, bends and connections. To provide the necessary pipe and fittings for gas-lights in the retort house, engine and boiler houses, yard and offices. |
| <b>TOOLS</b>                                                                                                                                                                                                                                                                                                                                                                                                                                                                                                                    | Four sets of stoking tools, 4 firing shovels, 4 charging shovels, 8 charging scoops with carrying bars and stands, 2 iron coke waggons, 2 iron coal waggons, 2 weighing machines, one for coal and one for coke, with weights, 4 galvanized iron cisterns for water for retort house, each to hold 30 gallons, 6 galvanized iron pails, 4 2-gallon water pots, 4 pairs of sight hole tongs, 4 augers for ascension pipes, 4 trowels, 6 coal hammers, 4 retort lid scrapers, 2 coal shovels, 2 coke shovels, 4 lime shovels, 4 sieves for lime, 2 brass syphon pumps. To provide all bolts, pins, rivets, cement, lead, yarn, red and white lead, paint and oil, requisite to fix the above, and to give the whole one coat of metallic oxide paint after completion.<br>250 tons.                                                                                                                                                                                                                                                                                                                                                                                                                                                                                                                                      |
| <p>Total Dead Weight of Ironwork.<br/>Measurement in cubic feet additional.<br/>Export Price delivered at the Docks in London, Liverpool, or Hull, inclusive of packing and Cases.<br/>Home Price delivered at St. Neots Station, and erected complete in England, exclusive of buildings, foundations, brick or woodwork, or scaffolding.<br/>Quantity of Firebricks, etc., required to set Retorts.</p> <p>Weight of Firebricks, etc.<br/>Price of Firebricks, etc., delivered at the Docks in London, Liverpool or Hull.</p> | <p>21,000 square and 4000 arch bricks, 90 lumps 23 in. <math>\times</math> 9 in. <math>\times</math> 4<math>\frac{1}{2}</math> in., 90 lumps 9 in. <math>\times</math> 9 in. <math>\times</math> 4<math>\frac{1}{2}</math> in., 90 lumps 6 in. <math>\times</math> 4<math>\frac{1}{2}</math> in. <math>\times</math> 6 in. <math>\times</math> 4<math>\frac{1}{2}</math> in., 90 lumps, 4 in. <math>\times</math> 4<math>\frac{1}{2}</math> in. <math>\times</math> 4<math>\frac{1}{2}</math> in., 45 lumps 10 in. <math>\times</math> 6 in. <math>\times</math> 4<math>\frac{1}{2}</math> in., 90 tiles 18 in. <math>\times</math> 12 in. <math>\times</math> 3 in., and 15 tons of fireclay.<br/>106 tons.</p>                                                                                                                                                                                                                                                                                                                                                                                                                                                                                                                                                                                                       |



SPECIFICATION OF APPARATUS FOR THE MANUFACTURE OF GAS FROM OILS, PETROLEUM, NAPHTHA, ETC.

|                                                                                                                                                        | <i>No. 1c Apparatus</i><br><i>To manufacture for, and supply with gas from Oils, Petroleum, Naphtha, etc., 100 burners for 6 hours, or 50 burners for 12 hours per day, each burner giving a light equal to 10 sperm candles.</i>                                                                                                                                                                                                                                                                                                                                                                                                                                                                                                                                                                                                                                                                                                                                                                                                                                                          | <i>No. 2c Apparatus</i><br><i>To manufacture for, and supply with gas from Oils, Petroleum, Naphtha, etc., 300 burners for 6 hours, or 150 burners for 12 hours per day, each burner giving a light equal to 10 sperm candles.</i>                                                                                                                                                                                                                                                                                                                                                                                                                                                                                                                                                                                                                                                                                                                                                                                                                                                                                                                                                                                                                                                                                                        |
|--------------------------------------------------------------------------------------------------------------------------------------------------------|--------------------------------------------------------------------------------------------------------------------------------------------------------------------------------------------------------------------------------------------------------------------------------------------------------------------------------------------------------------------------------------------------------------------------------------------------------------------------------------------------------------------------------------------------------------------------------------------------------------------------------------------------------------------------------------------------------------------------------------------------------------------------------------------------------------------------------------------------------------------------------------------------------------------------------------------------------------------------------------------------------------------------------------------------------------------------------------------|-------------------------------------------------------------------------------------------------------------------------------------------------------------------------------------------------------------------------------------------------------------------------------------------------------------------------------------------------------------------------------------------------------------------------------------------------------------------------------------------------------------------------------------------------------------------------------------------------------------------------------------------------------------------------------------------------------------------------------------------------------------------------------------------------------------------------------------------------------------------------------------------------------------------------------------------------------------------------------------------------------------------------------------------------------------------------------------------------------------------------------------------------------------------------------------------------------------------------------------------------------------------------------------------------------------------------------------------|
| RETORT STACK                                                                                                                                           | Two DIAPHRAGM RETORTS, each Retort to be capable of producing 40 cubic feet of gas per hour, and to be each fitted with mouthpieces, 2 covers, gearing for opening and closing, and bolts. To provide 2 cast iron cases for receiving Retorts, fitted complete with doors, fire bars and frames, dampers and 30 feet of sheet iron smoke pipe. To provide for feeding the Retorts with oils, etc., and water, 2 feed pipes, 4 syphons and funnels, one feed cistern 20 in. long X 10 in. wide X 15 in. deep; 1 feed cistern 20 in. long X 6 in. wide X 12 in. deep, 2 Patent Syphon Floats for maintaining an unvarying flow of liquid, fitted with 4 feed cocks and pipes. To provide 2 3-in. ascension pipes, 2 3-in. N shaped pipes with cleaning plugs, 2 3-in. dip pipes and bolts. To provide one Hydraulic Main constructed with Self-Acting Arrangement for removing the dip when the Retorts are in work, and replacing it when the doors are removed; provided with dip cistern, overflow pipes, holder, tank, gearing, cocks, and piping, 2 crutches to support Hydraulic Main. | Two DIAPHRAGM Retorts, each Retort to be capable of producing 80 cubic feet of gas per hour, and to be each fitted with mouthpiece, 2 covers, gearing for opening and closing, and bolts. To provide 2 furnaces for heating Retorts, consisting of 2 evaporating pans, 6 furnace bars, 2 bearers, 2 dead plates, 2 doors and frames fitted, 6 sight boxes and covers, 2 damper tiles with wrought iron rods and bolts, 4 shield tiles for furnace doors; also, 10 pilasters, 4 dwarf pilasters, 2 cross girders and bolts, and 5 tie bolts for bracing the brickwork together. To provide for feeding the Retorts with naphtha and water, 2 feed pipes, 4 syphons and funnels, 1 feed cistern 3 ft. 3 in. long X 10 in. wide X 20 in. deep; 1 feed cistern 3 ft. 3 in. long X 10 in. wide X 12 in. deep, 2 Patent Syphon Floats for maintaining an unvarying flow of liquid, fitted with 4 feed cocks and pipes. To provide 2 4-in. ascension pipes, 2 4-in. N shaped pipes fitted with cleaning plugs, 2 4-in. dip pipes and bolts. To provide 1 Hydraulic Main 4 ft. 6 in. long, constructed with Self-Acting Arrangement for removing the dip when the Retorts are in work, and replacing it when the door is removed; provided with dip cistern, overflow pipes, holder, tank, gearing, cocks and piping, 2 crutches to support Main. |
| CONDENSER, ETC.                                                                                                                                        | One PATENT COMBINED CONDENSING AND WASHING VESSELS, 4 ft. X 4 ft. X 12 in. deep, 2 dip cisterns, inlet and outlet pipes and bolts.                                                                                                                                                                                                                                                                                                                                                                                                                                                                                                                                                                                                                                                                                                                                                                                                                                                                                                                                                         | TWO PATENT COMBINED CONDENSING AND WASHING VESSELS, each 4 ft. X 4 ft. X 12 deep, 2 dip cisterns, inlet and outlet pipes and bolts; also cast iron frames and bolts for supporting the upper boxes.                                                                                                                                                                                                                                                                                                                                                                                                                                                                                                                                                                                                                                                                                                                                                                                                                                                                                                                                                                                                                                                                                                                                       |
| GASHOLDER                                                                                                                                              | One GASHOLDER, 10 ft. diameter X 6 ft. deep at the sides, containing 470 cubic feet; the sheets forming the crown and sides to be of No. 16 Birmingham wire gauge thickness, with strong and suitable internal framework; 3 guide columns each 7 ft. 6 in. high, 3 wrought iron girders and bolts to connect the tops of columns, 9 foundation bolts and 3 plates; 3 sets of chain slings, pulleys, carriages, axles, balance weights and bolts; 3 guide pulleys with carriages, adjusting plates, axles and bolts for top of sides, and 6 guide rollers with carriages, axles and bolts for bottom of sides of Gasholder.                                                                                                                                                                                                                                                                                                                                                                                                                                                                 | One GASHOLDER, 14 ft. deep in diameter X 8 ft. deep at the sides, containing 1,250 cubic feet; the sheets forming the crown and sides to be of No. 16 Birmingham Wire Gauge thickness, with strong and suitable internal framework; 3 guide columns each 9 feet high, 3 wrought iron girders and bolts to connect the tops of columns, 9 foundation bolts and 3 plates; 3 sets of chain slings, pulleys, carriages, axles, balance weights and bolts; 3 guide pulleys with carriages, adjusting plates, axles and bolts for top of sides, and 6 guide rollers with carriages, axles and bolts for bottom of sides of Gasholder.                                                                                                                                                                                                                                                                                                                                                                                                                                                                                                                                                                                                                                                                                                           |
| SUNDRIES                                                                                                                                               | The necessary 2 in. connecting pipe, not exceeding 18 yards from the Hydraulic Main to condenser, into and out of Gasholder to outlet valve, and to tar well, 2 2-in. valves for inlet and outlet to Gasholder, 2 tank syphons; 2 3/4-in. suction pipes, 1 brass syphon pump, 1 set of stoking tools. All bolts, pins, rivets, cement, lead, yarn, red and white lead, paint and oil, requisite to fix the above, and to give the whole one coat of paint after completion. The various parts to be plainly and legibly marked for fixing, and all parts liable to injury or loss in transit to be packed in strong and suitable cases.                                                                                                                                                                                                                                                                                                                                                                                                                                                    | Seven yards of 3-in. connecting pipe from the Hydraulic Main to condensers, and 20 yards of 2-in. connecting pipe from condensers in and out of gasholder to outlet valve, and to tar well; 2 2-in. valves for inlet and outlet to Gasholder, 2 tank syphons, 2 3/4-in. suction pipes, 1 brass syphon pump, 1 set of stoking tools. All bolts, pins, rivets, cement, lead, yarn, red and white lead, paint and oil, requisite to fix the above, and to give the whole one coat of paint after completion. The various parts to be plainly and legibly marked for fixing, and all parts liable to injury or loss in transit to be packed in strong and suitable cases.                                                                                                                                                                                                                                                                                                                                                                                                                                                                                                                                                                                                                                                                     |
| Total Dead Weight of Iron-work.                                                                                                                        | 4 1/4 tons.                                                                                                                                                                                                                                                                                                                                                                                                                                                                                                                                                                                                                                                                                                                                                                                                                                                                                                                                                                                                                                                                                | 7 tons.                                                                                                                                                                                                                                                                                                                                                                                                                                                                                                                                                                                                                                                                                                                                                                                                                                                                                                                                                                                                                                                                                                                                                                                                                                                                                                                                   |
| Export Price delivered at the Docks in London, Liverpool, or Hull.                                                                                     |                                                                                                                                                                                                                                                                                                                                                                                                                                                                                                                                                                                                                                                                                                                                                                                                                                                                                                                                                                                                                                                                                            |                                                                                                                                                                                                                                                                                                                                                                                                                                                                                                                                                                                                                                                                                                                                                                                                                                                                                                                                                                                                                                                                                                                                                                                                                                                                                                                                           |
| Home Price delivered at St. Neots Station, and erected complete in England, exclusive of buildings, foundations, brickwork, wood-work, or scaffolding. |                                                                                                                                                                                                                                                                                                                                                                                                                                                                                                                                                                                                                                                                                                                                                                                                                                                                                                                                                                                                                                                                                            |                                                                                                                                                                                                                                                                                                                                                                                                                                                                                                                                                                                                                                                                                                                                                                                                                                                                                                                                                                                                                                                                                                                                                                                                                                                                                                                                           |

SPECIFICATION OF APPARATUS FOR THE MANUFACTURE OF GAS FROM OILS, PETROLEUM, NAPHTHA, &c.—*continued.*

|                                                                                                                                                       | <i>No. 3c Apparatus</i><br><i>To Manufacture for, and supply with gas from Oils, Petroleum, Naphtha, &amp;c., 500 burners for 6 hours, or 250 burners for 12 hours per day, each burner giving a light equal to 10 sperm candles.</i>                                                                                                                                                                                                                                                                                                                                                                                                                                                                                                                                                                                                                                                                                                                                                                                                                                                                                                                                                                                                                                                                                                                                                                                    | <i>No. 4c Apparatus</i><br><i>To manufacture for, and supply with gas from Oils, Petroleum, Naphtha, etc., 800 burners for 6 hours, or 400 burners for 12 hours per day, each burner giving a light equal to 10 sperm candles.</i>                                                                                                                                                                                                                                                                                                                                                                                                                                                                                                                                                                                                                                                                                                                                                                                                                                                                                                                                                                                                                                                                                                                                                                                  |
|-------------------------------------------------------------------------------------------------------------------------------------------------------|--------------------------------------------------------------------------------------------------------------------------------------------------------------------------------------------------------------------------------------------------------------------------------------------------------------------------------------------------------------------------------------------------------------------------------------------------------------------------------------------------------------------------------------------------------------------------------------------------------------------------------------------------------------------------------------------------------------------------------------------------------------------------------------------------------------------------------------------------------------------------------------------------------------------------------------------------------------------------------------------------------------------------------------------------------------------------------------------------------------------------------------------------------------------------------------------------------------------------------------------------------------------------------------------------------------------------------------------------------------------------------------------------------------------------|---------------------------------------------------------------------------------------------------------------------------------------------------------------------------------------------------------------------------------------------------------------------------------------------------------------------------------------------------------------------------------------------------------------------------------------------------------------------------------------------------------------------------------------------------------------------------------------------------------------------------------------------------------------------------------------------------------------------------------------------------------------------------------------------------------------------------------------------------------------------------------------------------------------------------------------------------------------------------------------------------------------------------------------------------------------------------------------------------------------------------------------------------------------------------------------------------------------------------------------------------------------------------------------------------------------------------------------------------------------------------------------------------------------------|
| RETORT STACK                                                                                                                                          | THREE DIAPHRAGM RETORTS, each Retort to be capable of producing 80 cubic feet of gas per hour, and to be each fitted with mouthpiece, 2 covers, gearing for opening and closing, and bolts. To provide 2 furnaces for heating Retorts, consisting of 2 evaporating pans, 6 furnace bars, 2 bearers, 2 dead plates, 2 doors and frames fitted, 9 sight boxes and covers, 2 damper tiles with wrought iron rods and bolts, 4 shield tiles for furnace doors; also, 10 pilasters, 4 dwarf pilasters, 2 cross girders and bolts, and 5 tie bolts for bracing the brickwork together. To provide for feeding the Retorts with naphtha and water, 3 feed pipes, 6 syphons and funnels, one feed cistern 4 ft. 6 in. long X 10 in. wide X 20 in. deep; 1 feed cistern 4 ft. 6 in. long X 6 in. wide X 12 in. deep, 2 Patent Syphon Floats for maintaining an unvarying flow of liquid, fitted with 6 feed cocks and pipes. To provide 3 4-in. ascension pipes, 3 4-in. N shaped pipes fitted with cleaning plugs, 3 4-in. dip pipes and bolts. To provide one Hydraulic Main of sufficient length to receive the dip pipes from all three Retorts, and constructed with Patent Self-Acting Arrangement for removing the dip when the Retorts are in work, and replacing it when the door is removed; provided with dip cistern, overflow pipes, holder, tank, gearing, cocks, and piping, 3 crutches to support Hydraulic Main. | FOUR DIAPHRAGM RETORTS, each Retort to be capable of producing 100 cubic feet of gas per hour, and to be each fitted with mouthpiece, 2 covers, gearing for opening and closing, and bolts. To provide 2 furnaces for heating Retorts, consisting of 2 evaporating pans, 6 furnace bars, 2 bearers, 2 dead plates, 2 doors and frames fitted, 9 sight boxes and covers, 2 damper tiles with wrought iron rods and bolts, 4 shield tiles for furnace doors; also, 10 pilasters, 4 dwarf pilasters, 2 cross girders and bolts, and 5 tie bolts for bracing the brickwork together. To provide for feeding the Retorts with oils, &c., and water, 4 feed pipes, 8 syphons and funnels, one feed cistern 4 ft. 6 in. long X 14 in. wide X 20 in. deep; 1 feed cistern 4 ft. 6 in. long X 6 in. wide X 12 in. deep, 2 Patent Syphon Floats for maintaining an unvarying flow of liquid, fitted with 8 feed cocks and pipes. To provide 4 4-in. ascension pipes 4 4-in. N shaped pipes fitted with cleaning plugs, 4 4-in. dip pipes and bolts. To provide one Hydraulic Main of sufficient length to receive the dip pipes from all the Retorts, and constructed with Self-Acting Arrangement for removing the dip when the Retorts are in work, and replacing it when the doors are removed; provided with dip cistern, overflow pipes, holder, tank, gearing, cocks, and piping, 3 crutches to support Hydraulic Main. |
| CONDENSER, ETC.                                                                                                                                       | Three PATENT COMBINED CONDENSING AND WASHING VESSELS, each 4 ft. X 4 ft. X 12 in. deep, 2 dip cisterns, inlet and outlet pipes and bolts; also cast iron framing and bolts for supporting the upper boxes.                                                                                                                                                                                                                                                                                                                                                                                                                                                                                                                                                                                                                                                                                                                                                                                                                                                                                                                                                                                                                                                                                                                                                                                                               | FOUR PATENT COMBINED CONDENSING AND WASHING VESSELS, each 4 ft. X 4 ft. X 12 in. deep, 3 dip cisterns, 4 3-in. inlet and outlet elbows, 4 3-in. T pipes and bolts; also cast iron framing and bolts for supporting the upper boxes.                                                                                                                                                                                                                                                                                                                                                                                                                                                                                                                                                                                                                                                                                                                                                                                                                                                                                                                                                                                                                                                                                                                                                                                 |
| GASHOLDER                                                                                                                                             | One GASHOLDER, 18 feet diameter X 10 feet deep at the sides, containing 2600 cubic feet; the sheets forming the crown and sides to be of No. 16 Birmingham wire guage thickness, with strong and suitable internal framework; 3 cast iron guide columns each 11 feet high, 3 wrought iron girders and bolts to connect the tops of columns, 9 foundation bolts and 3 plates; 3 sets of chain slings, pulleys, carriages, axles, balance weights and bolts; 3 guide pulleys with carriages, adjusting plates, axles and bolts for top of sides, and 6 guide rollers with carriages, axles and bolts for bottom of sides of Gasholder.                                                                                                                                                                                                                                                                                                                                                                                                                                                                                                                                                                                                                                                                                                                                                                                     | One GASHOLDER, 22 ft. diameter X 10 ft. deep at the sides, containing 3800 cubic feet; the sheets forming the crown and sides to be of No. 16 Birmingham wire guage thickness, with strong and suitable internal framework; 3 cast iron guide columns each 11 feet high, 3 wrought iron girders and bolts to connect the tops of columns, 9 foundation bolts and 3 plates; 3 sets of chain slings, pulleys, carriages, axles, balance weights and bolts; 3 guide pulleys with carriages, adjusting plates, axles and bolts for top of sides, and 6 guide rollers with carriages, axles and bolts for bottom of sides of Gasholder.                                                                                                                                                                                                                                                                                                                                                                                                                                                                                                                                                                                                                                                                                                                                                                                  |
| SUNDRIES                                                                                                                                              | All the 3-in. connecting pipes not exceeding 100 feet in length, from the Hydraulic Main to Condensers, into and out of Gasholder to outlet valve, also 10 yards of 2-in. pipe to connect the dip cisterns and to tar well; also 2 3-in. valves for inlet and outlet to Gasholder, 2 3-in. tank syphons, 2 ¾-in. suction pipes, 1 brass syphon pump, 1 set of stoking tools. All bolts, pins, rivets, cement, lead, yarn, red and white lead, paint and oil, requisite to fix the above, and to give the whole one coat of paint after completion. The various parts to be plainly and legibly marked for fixing, and all parts liable to injury or loss in transit to be packed in strong and suitable cases.                                                                                                                                                                                                                                                                                                                                                                                                                                                                                                                                                                                                                                                                                                           | All the 3-in. connecting pipes not exceeding 100 feet in length, from the Hydraulic Main to Condensers, into and out of Gasholder to outlet valve, also 10 yards of 2 in. pipe for connecting the dip cisterns, and from thence to well, 2 3-in. valves for inlet and outlet of Gasholder, 2 3-in. tank syphons, 2 ¾-in. suction pipes, 1 brass syphon pump, 1 set of stoking tools. All bolts, pins, rivets, cement, lead, yarn, red and white lead, paint and oil, requisite to fix the above, and to give the whole one coat of metallic oxide paint after completion. The various parts to be plainly and legibly marked for fixing, and all parts liable to injury or loss in transit to be packed in strong and suitable cases.                                                                                                                                                                                                                                                                                                                                                                                                                                                                                                                                                                                                                                                                               |
| Total Dead Weight of Iron-work.                                                                                                                       | 10½ tons.                                                                                                                                                                                                                                                                                                                                                                                                                                                                                                                                                                                                                                                                                                                                                                                                                                                                                                                                                                                                                                                                                                                                                                                                                                                                                                                                                                                                                | 11½ tons.                                                                                                                                                                                                                                                                                                                                                                                                                                                                                                                                                                                                                                                                                                                                                                                                                                                                                                                                                                                                                                                                                                                                                                                                                                                                                                                                                                                                           |
| Export Price delivered at the Docks in London, Liverpool, or Hull.                                                                                    |                                                                                                                                                                                                                                                                                                                                                                                                                                                                                                                                                                                                                                                                                                                                                                                                                                                                                                                                                                                                                                                                                                                                                                                                                                                                                                                                                                                                                          |                                                                                                                                                                                                                                                                                                                                                                                                                                                                                                                                                                                                                                                                                                                                                                                                                                                                                                                                                                                                                                                                                                                                                                                                                                                                                                                                                                                                                     |
| Home Price delivered at St. Neots Station, and erected complete in England, exclusive of buildings, foundations, brickwork, woodwork, or scaffolding. |                                                                                                                                                                                                                                                                                                                                                                                                                                                                                                                                                                                                                                                                                                                                                                                                                                                                                                                                                                                                                                                                                                                                                                                                                                                                                                                                                                                                                          |                                                                                                                                                                                                                                                                                                                                                                                                                                                                                                                                                                                                                                                                                                                                                                                                                                                                                                                                                                                                                                                                                                                                                                                                                                                                                                                                                                                                                     |

SPECIFICATIONS OF APPARATUS FOR THE MANUFACTURE OF GAS FROM OILS, PETROLEUM, NAPHTHA, &c.—*continued.*

|                                                                                                                                                      | <i>No. 5c Apparatus</i><br><i>To manufacture for and supply with gas from Oils, Petroleum, Naphtha, &amp;c., 1,200 burners for 6 hours, or 600 burners for 12 hours per day, each burner giving a light equal to 10 sperm candles.</i>                                                                                                                                                                                                                                                                                                                                                                                                                                                                                                                                                                                                                                                                                                                                                                                                                                                                                                                                                                                                                                                                                                                                                                                           | <i>No. 6c Apparatus</i><br><i>To manufacture for, and supply with gas from Oils, Petroleums, Naphtha, &amp;c., 1600 burners for 6 hours, or 800 burners for 12 hours per day, each burner giving a light equal to 10 sperm candles.</i>                                                                                                                                                                                                                                                                                                                                                                                                                                                                                                                                                                                                                                                                                                                                                                                                                                                                                                                                                                                                                                                                                                                                                                                                |
|------------------------------------------------------------------------------------------------------------------------------------------------------|----------------------------------------------------------------------------------------------------------------------------------------------------------------------------------------------------------------------------------------------------------------------------------------------------------------------------------------------------------------------------------------------------------------------------------------------------------------------------------------------------------------------------------------------------------------------------------------------------------------------------------------------------------------------------------------------------------------------------------------------------------------------------------------------------------------------------------------------------------------------------------------------------------------------------------------------------------------------------------------------------------------------------------------------------------------------------------------------------------------------------------------------------------------------------------------------------------------------------------------------------------------------------------------------------------------------------------------------------------------------------------------------------------------------------------|----------------------------------------------------------------------------------------------------------------------------------------------------------------------------------------------------------------------------------------------------------------------------------------------------------------------------------------------------------------------------------------------------------------------------------------------------------------------------------------------------------------------------------------------------------------------------------------------------------------------------------------------------------------------------------------------------------------------------------------------------------------------------------------------------------------------------------------------------------------------------------------------------------------------------------------------------------------------------------------------------------------------------------------------------------------------------------------------------------------------------------------------------------------------------------------------------------------------------------------------------------------------------------------------------------------------------------------------------------------------------------------------------------------------------------------|
| RETORT STACK                                                                                                                                         | Six DIAPHRAGM RETORTS, each Retort to be capable of producing 100 cubic feet of gas per hour, and to be each fitted with mouthpiece, 2 covers, improved gearing for opening and closing, and bolts. To provide 3 furnaces for heating Retorts, consisting of 3 evaporating pans, 9 furnace bars, 3 bearers, 3 dead plates, 3 doors and frames fitted, 15 sight boxes and covers, 3 damper tiles with wrought iron rods and bolts, 6 shield tiles for furnace doors; also 12 pilasters, 6 dwarf pilasters, 3 cross girders and bolts, and 6 tie bolts for bracing the brickwork together. To provide for feeding the Retorts with oils, &c., and water, 6 feed pipes, 12 syphons and funnels, 1 feed cistern 8 ft. 6 in. long X 14 in. wide X by 20 in. deep; 1 feed cistern 8 ft. 6 in. long X 6 in. wide X 12 in. deep; 2 Patent Syphon Floats for maintaining an unvarying flow of liquid, fitted with 12 feed cocks and pipes. To provide 6 4-in. ascension pipes, 6 4-in. N shaped pipes, fitted with cleaning plugs, 6 4-in. dip pipes and bolts. To provide one Hydraulic Main of sufficient length to receive the dip pipes from all the Retorts, and constructed with Self-acting Arrangement for removing the dip when the Retorts are in work, and replacing it when the doors are removed; provided with dip cistern, overflow pipes, holder, tank, gearing, cocks, and piping, 4 crutches to support Hydraulic Main. | Nine DIAPHRAGM RETORTS, each Retort to be capable of producing 100 cubic feet of gas per hour, and to be each fitted with mouthpiece, 2 covers, gearing for opening and closing, and bolts. To provide 3 furnaces for heating Retorts, consisting of 3 evaporating pans, 9 furnace bars, 3 bearers, 3 dead plates, 3 doors and frames fitted, 18 sight boxes and covers, 3 damper tiles with wrought-iron rods and bolts, 8 shield tiles for furnace doors; also, 12 pilasters, 6 dwarf pilasters, 3 cross girders, 6 countersunk bolts, and 6 wrought iron tie rods for bracing the brickwork together. To provide for feeding the Retorts with oils, &c., and water, 9 feed pipes, 18 syphons and funnels, one feed cistern 10 feet long X 14 in. wide X 20 in. deep; 1 feed cistern 10 feet long X 6 in. wide X 12 in. deep, 2 Patent Syphon Floats for maintaining an unvarying flow of liquid, fitted with 18 feed cocks and pipes. To provide 9 4-in. ascension pipes, 9 4-in. N shaped pipes fitted with cleaning plugs, 9 4-in. dip pipes and bolts. To provide one Hydraulic Main of sufficient length to receive the dip pipes from all the Retorts, and constructed with Self-Acting Arrangement for removing the dip when the Retorts are in work, and replacing it when the doors are removed; provided with dip cistern, overflow pipes, holder, tank, gearing, cocks, and piping, 4 crutches to support Hydraulic Main. |
| CONDENSER; Etc.                                                                                                                                      | FOUR PATENT COMBINED CONDENSING AND WASHING VESSELS, each 5 ft. X 5 ft. X 14 in. deep, 3 dip cisterns, 4 4-in. inlet and outlet elbows, 4 4-in. T pipes and bolts; also cast iron framing and bolts for supporting the upper boxes.                                                                                                                                                                                                                                                                                                                                                                                                                                                                                                                                                                                                                                                                                                                                                                                                                                                                                                                                                                                                                                                                                                                                                                                              | SIX PATENT COMBINED CONDENSING AND WASHING VESSELS, each 5 ft. X 5 ft. X 14 in. deep, 3 dip cisterns, 4 4-in. inlet and outlet elbows, 4 4-in. T pipes and bolts; also cast iron framing and bolts for supporting the upper boxes.                                                                                                                                                                                                                                                                                                                                                                                                                                                                                                                                                                                                                                                                                                                                                                                                                                                                                                                                                                                                                                                                                                                                                                                                     |
| GASHOLDER                                                                                                                                            | One GASHOLDER, 25 ft. in diameter X 10 ft. deep at the sides, and containing 5,000 cubic feet; the sheets forming the crown and sides to be of No. 16 Birmingham wire gauge thickness, with strong and suitable internal framework; 4 cast iron guide columns, each 11 ft. high; 4 wrought iron girders and bolts to connect the tops of columns; 12 foundation bolts and 4 plates; 4 guide pulleys with carriages, adjusting plates, axles and bolts for top of sides, and 8 guide rollers, with carriages, axles, and bolts for bottom of sides of Gasholder, 4 caps for top of columns.                                                                                                                                                                                                                                                                                                                                                                                                                                                                                                                                                                                                                                                                                                                                                                                                                                       | One GASHOLDER, 30 feet diameter X 10 feet deep at the sides, containing 7,000 cubic feet; the sheets forming the crown and sides to be of No. 16 Birmingham wire gauge thickness, with strong and suitable internal framework; 4 cast iron guide columns each 11 feet high; 4 trussed wrought iron girders and bolts to connect the tops of columns; 12 foundation bolts and 4 plates; 4 guide pulleys with carriages, adjusting plates, axles and bolts for top of sides, and 8 guide rollers with carriages, axles, and bolts for bottom of sides of Gasholder, 4 caps for top of columns.                                                                                                                                                                                                                                                                                                                                                                                                                                                                                                                                                                                                                                                                                                                                                                                                                                           |
| SUNDRIES                                                                                                                                             | All the 4-in. connecting pipes not exceeding 40 yards in length, from the Hydraulic Main to condensers, into and out of Gasholder to outlet valve, also 10 yards of 3-in. pipe for connecting the tar dip cisterns, and from thence to well, 2 4-in. valves for inlet and outlet of Gasholder, 2 4-in. tank syphons, 2 1/2-in. suction pipes, 1 brass syphon pump, 1 set of stoking tools. All bolts, pins, rivets, cement, lead, yarn, red and white lead, paint and oil, requisite to fix the above, and to give the whole one coat of metallic oxide paint after completion. The various parts to be plainly and legibly marked for fixing, and all parts liable to injury or loss in transit to be packed in strong and suitable cases.                                                                                                                                                                                                                                                                                                                                                                                                                                                                                                                                                                                                                                                                                      | All the 4-in. connecting pipes not exceeding 40 yards in length, from the Hydraulic Main to condensers, into and out of Gasholder to outlet valve, also 10 yards of 3-in. pipe for connecting the dip cisterns, and from thence to tar well, 2 4-in. valves for inlet and outlet of Gasholder, 2 4-in. tank syphons, 2 1/2-in. suction pipes, 1 brass syphon pump, 1 set of stoking tools. All bolts, pins, rivets, cement, lead, yarn, red and white lead, paint and oil, requisite to fix the above, and to give the whole one coat of metallic oxide paint after completion. The various parts to be plainly and legibly marked for fixing, and all parts liable to injury or loss in transit to be packed in strong and suitable cases.                                                                                                                                                                                                                                                                                                                                                                                                                                                                                                                                                                                                                                                                                            |
| Total Dead Weight of Iron-work.                                                                                                                      | 17 tons.                                                                                                                                                                                                                                                                                                                                                                                                                                                                                                                                                                                                                                                                                                                                                                                                                                                                                                                                                                                                                                                                                                                                                                                                                                                                                                                                                                                                                         | 22 tons.                                                                                                                                                                                                                                                                                                                                                                                                                                                                                                                                                                                                                                                                                                                                                                                                                                                                                                                                                                                                                                                                                                                                                                                                                                                                                                                                                                                                                               |
| Export Price delivered at the Docks in London, Liverpool, or Hull.                                                                                   |                                                                                                                                                                                                                                                                                                                                                                                                                                                                                                                                                                                                                                                                                                                                                                                                                                                                                                                                                                                                                                                                                                                                                                                                                                                                                                                                                                                                                                  |                                                                                                                                                                                                                                                                                                                                                                                                                                                                                                                                                                                                                                                                                                                                                                                                                                                                                                                                                                                                                                                                                                                                                                                                                                                                                                                                                                                                                                        |
| Home Price delivered at St. Neots Station, and erected complete in England, exclusive of buildings, foundations, brick or wood-work, or scaffolding. |                                                                                                                                                                                                                                                                                                                                                                                                                                                                                                                                                                                                                                                                                                                                                                                                                                                                                                                                                                                                                                                                                                                                                                                                                                                                                                                                                                                                                                  |                                                                                                                                                                                                                                                                                                                                                                                                                                                                                                                                                                                                                                                                                                                                                                                                                                                                                                                                                                                                                                                                                                                                                                                                                                                                                                                                                                                                                                        |

SPECIFICATIONS OF APPARATUS FOR THE MANUFACTURE OF GAS FROM OILS, PETROLEUM, NAPHTHA, &c.—*continued.*

| <i>No. 7c Apparatus</i>                                                                                                                                                                                      |                                                                                                                                                                                                                                                                                                                                                                                                                                                                                                                                                                                                                                                                                                                                                                                                                                                                                                                                                                                                                                                                                                                                                                                                                                                                                                                                                                                                                                                                                                                                                                  |
|--------------------------------------------------------------------------------------------------------------------------------------------------------------------------------------------------------------|------------------------------------------------------------------------------------------------------------------------------------------------------------------------------------------------------------------------------------------------------------------------------------------------------------------------------------------------------------------------------------------------------------------------------------------------------------------------------------------------------------------------------------------------------------------------------------------------------------------------------------------------------------------------------------------------------------------------------------------------------------------------------------------------------------------------------------------------------------------------------------------------------------------------------------------------------------------------------------------------------------------------------------------------------------------------------------------------------------------------------------------------------------------------------------------------------------------------------------------------------------------------------------------------------------------------------------------------------------------------------------------------------------------------------------------------------------------------------------------------------------------------------------------------------------------|
| <i>To manufacture for and supply with gas from Oils, Petroleum, Naphtha, &amp;c., 2000 burners for 6 hours, or 1,000 burners for 12 hours per day, each burner giving a light equal to 10 sperm candles.</i> |                                                                                                                                                                                                                                                                                                                                                                                                                                                                                                                                                                                                                                                                                                                                                                                                                                                                                                                                                                                                                                                                                                                                                                                                                                                                                                                                                                                                                                                                                                                                                                  |
| RETORT STACK                                                                                                                                                                                                 | Twelve DIAPHRAGM RETORTS, each Retort to be capable of producing 100 cubic feet of gas per hour, and to be each fitted with mouthpieces, covers (two to each Retort), gearing for opening and closing, and bolts. To provide 4 furnaces for heating the Retorts, consisting of 4 evaporating pans, 12 furnace bars, 4 bearers, 4 dead plates, 4 doors and frames fitted, 24 sight boxes and covers, 4 damper tiles with wrought iron rods and bolts, 8 shield tiles for furnace doors; also 14 pilasters, 8 dwarf pilasters, 4 cross girders, 8 countersunk bolts, and 7 wrought iron tie rods for bracing the brickwork together. To provide for feeding the Retorts with oils, &c., and water, 12 feed pipes, 24 syphons and funnels, one feed cistern 14 feet long $\times$ 14 in. wide $\times$ 20 in. deep; 1 feed cistern 14 feet long $\times$ 14 in. wide $\times$ 20 in. deep; 1 feed cistern 14 feet long $\times$ 6 in. $\times$ 12 in. deep, 2 Patent Syphon Floats for maintaining an unvarying flow of liquid, fitted with 24 feed cocks and pipes. To provide 12 4-in. ascension pipes, 12 4-in. N shaped pipes fitted with cleaning plugs, 12 4-in. dip pipes and bolts. To provide 1 Hydraulic Main of sufficient length to receive the dip pipes from all the Retorts, and constructed with Self-Acting Arrangement for removing the dip when the Retorts are in work, and replacing it when the doors are removed; provided with dip cistern, overflow pipes, holder, tank, gearing, cocks, and piping, 5 crutches to support Hydraulic Main. |
| CONDENSER                                                                                                                                                                                                    | Six PATENT COMBINED CONDENSING AND WASHING VESSELS, each 6 feet $\times$ 6 feet $\times$ 14 in. deep, 3 dip cisterns, 4 inlet and outlet elbows, 4 5-in. T pipes and bolts; also cast-iron framing and bolts for supporting the upper boxes.                                                                                                                                                                                                                                                                                                                                                                                                                                                                                                                                                                                                                                                                                                                                                                                                                                                                                                                                                                                                                                                                                                                                                                                                                                                                                                                     |
| GASHOLDER                                                                                                                                                                                                    | One GASHOLDER, 35 feet diameter $\times$ 10 feet deep at the sides, and containing 9,600 cubic feet: the sheets forming the crown and sides to be of No. 16 Birmingham wire gauge thickness, with strong and suitable internal framework: 5 cast-iron guide columns each 11 feet high; 5 trussed wrought iron girders and bolts to connect the tops of columns; 15 foundation bolts and 5 foundation plates: 5 guide pulleys, with carriages, adjusting plates, axles, and bolts for top of sides, and 10 guide rollers with carriages, axles, and bolts for bottom of sides of Gasholder, 5 caps for tops of columns.                                                                                                                                                                                                                                                                                                                                                                                                                                                                                                                                                                                                                                                                                                                                                                                                                                                                                                                                           |
| SUNDRIES                                                                                                                                                                                                     | All the 5-in. connecting pipes, not exceeding 50 yards, from the Hydraulic Main to condenser, into and out of Gasholder to outlet valve, also 10 yards of 3-in. pipe for connecting the tar dip cisterns and from thence to tar well: 2 5-in. valves for inlet and outlet of Gasholder, 2 5-in. tank syphons, 2 $\frac{3}{4}$ -in iron suction pipes, 1 brass syphon pump, 1 set of stoking tools. All bolts, pins, rivets, cement, lead, yarn, red and white lead, paint and oil, required to fix the above, and to give the whole one coat of metallic oxide paint after completion. The various parts to be plainly and legibly marked for fixing, and all parts liable to injury or loss in transit to be packed in strong and suitable cases.                                                                                                                                                                                                                                                                                                                                                                                                                                                                                                                                                                                                                                                                                                                                                                                                               |
| Total dead weight of Ironwork.                                                                                                                                                                               | 30 tons.                                                                                                                                                                                                                                                                                                                                                                                                                                                                                                                                                                                                                                                                                                                                                                                                                                                                                                                                                                                                                                                                                                                                                                                                                                                                                                                                                                                                                                                                                                                                                         |
| Export Price delivered at the Docks in London, Liverpool, or Hull,                                                                                                                                           |                                                                                                                                                                                                                                                                                                                                                                                                                                                                                                                                                                                                                                                                                                                                                                                                                                                                                                                                                                                                                                                                                                                                                                                                                                                                                                                                                                                                                                                                                                                                                                  |
| Home Price delivered at St. Neots Station, and erected complete in England, exclusive of buildings, foundations, brick or woodwork, or scaffolding.                                                          |                                                                                                                                                                                                                                                                                                                                                                                                                                                                                                                                                                                                                                                                                                                                                                                                                                                                                                                                                                                                                                                                                                                                                                                                                                                                                                                                                                                                                                                                                                                                                                  |

## GENERAL REMARKS ON THE CONSTRUCTION OF WORKS.

As already observed, when deciding on the choice of a site for a Gas Works, communication thereto by water or railway for facilitating the delivery of coal, lime, and all articles required, and for despatching coke and other products, is the first consideration. Then the locality chosen should, as far as possible, be so situated as to avoid complaints on sanitary grounds.

The nature of the site is also of the highest importance, as by selecting a solid ground, free from water, and particularly a clayey soil, a very considerable economy will be effected in the buildings. Made ground and marshy sites are always attended with extraordinary expenses, and in both instances the solid soil must be reached before commencing the foundations. The depth of marsh can be generally ascertained by probing with a  $\frac{3}{4}$  in. round rod of iron, which should be forced down perpendicularly in several places, in order to ascertain the exact depth of the solid substratum. When water exists in the site chosen, generally it is better to decide on a cast-iron tank for the Gasholder, which may be placed, in some cases, without requiring any foundation; but in very unstable ground it may be necessary to drive poles, or form a foundation of concrete, to support the tank, as well as other parts of the building and apparatus.

It is always advisable to use the building material common to the locality, and any attempted innovation is always attended with loss.

[M]

## DISTRIBUTION OF GAS.

GEORGE BOWER,

*Gas and Water Engineer and Contractor, St. Neots, Hunts.*

## DISTRIBUTION.

The distribution of gas commences with the mains, is continued with the services, lamp columns, lanterns, consumers' meters, gas fittings, and burners, to each of which subjects the reader's attention will be requested.

## MAIN PIPES.

During the early years of gas lighting, various means were proposed for the distribution of gas throughout a town, such as brick conduits, pipes of glass, wood, paper, and earthenware, all of which were proposed principally with a view to economy; but the expense of the production of gas, and the subtle nature of that fluid, together with the serious losses sustained by companies who unwisely adopted the means referred to, terminated in the universal adoption of cast-iron mains.

But not only has the best material for the mains been at times a matter of uncertainty, but also the most perfect method of making the joints; thus, flange joints with washers, or clips, in two or more segments, with a felt band placed around the two ends of the pipes to be joined, have been tried. Joints of hollow india-rubber, wooden wedges, cement, and pipes with turned and bored ends, have been suggested and applied, and eventually abandoned for the spigot and faucet pipe with lead joints, which is undoubtedly superior to all others, and almost universally employed.

The degree of perfection of this system of main laying is clearly proved by the operations of gas companies who adopt it, wherein the average loss of gas from all sources, or as termed, "unaccounted-for gas," is about 10 per cent. of the production, in which is included the loss of gas that must inevitably occur through decayed meters, or when laying new services or mains, or occasional fraud, or by the action of diffusion. If then all these points are considered, it is evident that the loss of gas by leakage must be very small; consequently, it may be concluded that spigot and faucet with lead joints leaves nothing to be desired, and is the best system that can be adopted.

Cast-iron pipes are affected in different ways, according to the soil in which they are embedded; thus, when laid in clay, the cast-iron is preserved in a remarkable manner, and when laid in a saline sandy soil, a coat of sesqui-oxide of iron is formed on the exterior, of a thickness corresponding with the time which it has been interred. Further, that pipes existing in made ground with cinders are speedily pierced with small holes and destroyed, and that when in contact with muddy soil, in the course of years the nature of the iron is changed into a kind of plumbago of that soft nature that it can be cut with a knife like the crust of bread. Hence, with these different effects of soils, it is evident that the term of the duration of mains can only be guessed at by a knowledge of the nature of the soil in which they are laid.

Here, however, it may be observed, that by giving pipes while hot a coating of tar, or of Dr. A. Smith's solution, the evil influence of the soil will be counteracted to a great degree. But a process for the preservation of iron from rust has been discovered and patented by Mr. Bower, which virtually renders iron indestructible. The process consists in subjecting pipes or any other iron work when at a red heat, and enclosed in a retort or chamber, to the action of oxygen, either pure or as it exists in the atmosphere. The iron takes up the oxygen and forms a film of magnetic oxide (Fe. 3, O. 4), which alone of all the oxides of iron is impervious to the action of air or water. It is believed that this process will supply a great want, as in many cases iron will take the place of the more expensive metals.

When defining the diameter of mains for any given locality, as a town or city, in most cases a good map is necessary, with a thorough knowledge of the various quarters, whether shops or manufactories exist, or private dwellings, where gas may eventually be required, or streets where only a few public lights will be wanted; in short, to study the means requisite for amply supplying the town, at the same time avoiding the expense of mains in localities where no return beyond the public lights will be derived from them. Moreover, the principal levels of the place should be taken, and indicated on the map, and from this the number and position of the syphons will be determined.

Mains should always be tested before laying, under a pressure of 300 feet of water, when any imperfections arising from pores, cracks, or other causes, will be readily detected. The process of testing is generally effected by the manufacturer, and should always be stipulated by gas and water companies when ordering pipes.

A good experienced main layer is of the utmost importance, who will lay thousands of yards of main without any perceptible leakage. Whereas, when the system of employing any smith or labourer for the purpose is adopted, it is always attended with serious and continuous loss and inconvenience, arising perhaps from some of the sockets of the pipes being split in the operation of caulking, or unsound joints, or the mains being out of their proper

level, when an accumulation of water impedes the passage of the gas; and it has frequently happened that after a length of main has been badly laid, that the whole length of the ground has had to be re-opened to repair the leakages, and give the proper incline to the pipes.

The length of the leading main from the works to a point where there will be a divergence of one or several pipes being obtained, and the maximum consumption of gas per hour for the supply of the town estimated, in which a considerable margin should be allowed for augmented business, then by reference to the following table of the delivery of gas the diameter of the pipe will be ascertained. To explain this, let it be supposed that the length of the pipe to the point of divergence is 1,250 yards, and that about 3,000 feet are required to be delivered per hour during the heaviest lighting, with a one-inch pressure on the works. Then, by referring to the quantity corresponding with the given length and pressure, we find that a five-inch main will be necessary. But in this, as in all the calculations of a new works, a considerable latitude has to be made beyond the actual present requirements of a town, as gas-lighting, once adopted, is always progressive.

DISCHARGES OF GAS IN CUBIC FEET PER HOUR THROUGH PIPES OF VARIOUS DIAMETERS AND LENGTHS AT DIFFERENT PRESSURES. THE SPECIFIC GRAVITY OF THE GAS ESTIMATED AT 400, AIR BEING 1000.

DIAMETER OF PIPE .5 INCH.

| Length in yards                           | 10   | 20   | 30   | 50   | 75   | 100  | 150  |
|-------------------------------------------|------|------|------|------|------|------|------|
| Quantity delivered with 0.1 inch pressure | 37.7 | 26.7 | 21.7 | 16.8 | 13.8 | 11.9 | 9.7  |
| " " 0.2 "                                 | 53.4 | 37.7 | 30.6 | 23.8 | 19.5 | 16.8 | 13.8 |
| " " 0.3 "                                 | 65.2 | 46.3 | 37.7 | 29.1 | 23.8 | 20.7 | 16.8 |
| " " 0.4 "                                 | ..   | ..   | ..   | 33.7 | 27.5 | 23.8 | 19.5 |
| " " 0.5 "                                 | ..   | ..   | ..   | ..   | ..   | 26.7 | 21.7 |

DIAMETER OF PIPE .75 INCH.

| Length in yards                           | 10    | 20    | 30    | 50   | 75   | 100  | 150  |
|-------------------------------------------|-------|-------|-------|------|------|------|------|
| Quantity delivered with 0.1 inch pressure | 104.3 | 73.8  | 60.0  | 46.6 | 37.9 | 32.9 | 26.9 |
| " " 0.2 "                                 | 147.5 | 104.3 | 84.9  | 65.8 | 53.7 | 46.6 | 37.9 |
| " " 0.3 "                                 | ..    | ..    | 104.3 | 80.9 | 65.8 | 57.0 | 46.6 |
| " " 0.4 "                                 | ..    | ..    | ..    | 93.2 | 75.9 | 65.8 | 53.8 |
| " " 0.5 "                                 | ..    | ..    | ..    | ..   | ..   | 73.8 | 60.0 |

DIAMETER OF PIPE 1 INCH.

| Length in yards                           | 10  | 20  | 30  | 50  | 75  | 100 | 150 |
|-------------------------------------------|-----|-----|-----|-----|-----|-----|-----|
| Quantity delivered with 0.1 inch pressure | 214 | 151 | 124 | 95  | 78  | 67  | 55  |
| " " 0.2 "                                 | 302 | 214 | 175 | 135 | 110 | 95  | 78  |
| " " 0.3 "                                 | ..  | ..  | 214 | 165 | 135 | 117 | 95  |
| " " 0.4 "                                 | ..  | ..  | ..  | 190 | 156 | 135 | 110 |
| " " 0.5 "                                 | ..  | ..  | ..  | ..  | ..  | 151 | 123 |

DIAMETER OF PIPE 1.25 INCH.

| Length in yards                           | 25  | 50  | 75  | 100 | 150 | 200 | 300 |
|-------------------------------------------|-----|-----|-----|-----|-----|-----|-----|
| Quantity delivered with 0.1 inch pressure | 236 | 167 | 137 | 118 | 96  | 84  | 68  |
| " " 0.2 "                                 | 333 | 236 | 192 | 167 | 137 | 118 | 106 |
| " " 0.3 "                                 | ..  | 289 | 236 | 205 | 167 | 144 | 118 |
| " " 0.4 "                                 | ..  | ..  | ..  | 236 | 192 | 167 | 137 |
| " " 0.5 "                                 | ..  | ..  | ..  | ..  | ..  | 187 | 152 |

DIAMETER OF PIPE 1.5 INCH.

| Length in yards                           | 25  | 50  | 75  | 100 | 150 | 200 | 300 |
|-------------------------------------------|-----|-----|-----|-----|-----|-----|-----|
| Quantity delivered with 0.1 inch pressure | 374 | 264 | 215 | 187 | 152 | 132 | 107 |
| " " 0.2 "                                 | 528 | 374 | 304 | 264 | 215 | 187 | 152 |
| " " 0.3 "                                 | ..  | 458 | 374 | 322 | 264 | 229 | 187 |
| " " 0.4 "                                 | ..  | ..  | ..  | 374 | 304 | 264 | 215 |
| " " 0.5 "                                 | ..  | ..  | ..  | ..  | ..  | 295 | 239 |

DIAMETER OF PIPE 2 INCHES.

| Length in yards                           | 50  | 75  | 100 | 150 | 200 | 300 | 500 |
|-------------------------------------------|-----|-----|-----|-----|-----|-----|-----|
| Quantity delivered with 0.1 inch pressure | 540 | 441 | 381 | 311 | 270 | 220 | 170 |
| " " 0.2 "                                 | 763 | 623 | 540 | 441 | 381 | 311 | 241 |
| " " 0.3 "                                 | ..  | 763 | 605 | 540 | 468 | 381 | 296 |
| " " 0.4 "                                 | ..  | ..  | ..  | 623 | 540 | 441 | 341 |
| " " 0.5 "                                 | ..  | ..  | ..  | ..  | ..  | 492 | 381 |

DISCHARGES OF GAS IN CUBIC FEET PER HOUR, &c.—continued.

DIAMETER OF PIPE 2.5 INCH.

| Length in yards .. .. .                         | 50   | 75   | 100  | 150  | 200 | 300 | 500 |
|-------------------------------------------------|------|------|------|------|-----|-----|-----|
| Quantity delivered with 0.1 inch pressure .. .. | 943  | 770  | 667  | 545  | 471 | 335 | 298 |
| " " 0.2 " .. ..                                 | 1335 | 1090 | 943  | 770  | 667 | 545 | 421 |
| " " 0.3 " .. ..                                 | ..   | 1335 | 1172 | 943  | 819 | 667 | 516 |
| " " 0.4 " .. ..                                 | ..   | ..   | ..   | 1090 | 943 | 770 | 596 |
| " " 0.5 " .. ..                                 | ..   | ..   | ..   | ..   | ..  | 861 | 667 |
| " " 0.6 " .. ..                                 | ..   | ..   | ..   | ..   | ..  | ..  | 731 |

DIAMETER OF PIPE 3 INCHES.

| Length in yards .. .. .                         | 100  | 150  | 250  | 500  | 750 | 1000 | 1250 |
|-------------------------------------------------|------|------|------|------|-----|------|------|
| Quantity delivered with 0.1 inch pressure .. .. | 1054 | 859  | 666  | 471  | 384 | 333  | 298  |
| " " 0.2 " .. ..                                 | 1440 | 1214 | 942  | 666  | 543 | 471  | 375  |
| " " 0.3 " .. ..                                 | ..   | 1487 | 1153 | 815  | 666 | 576  | 529  |
| " " 0.4 " .. ..                                 | ..   | ..   | 1332 | 942  | 768 | 666  | 596  |
| " " 0.5 " .. ..                                 | ..   | ..   | ..   | 1054 | 859 | 744  | 666  |
| " " 0.6 " .. ..                                 | ..   | ..   | ..   | ..   | 942 | 815  | 739  |
| " " 0.8 " .. ..                                 | ..   | ..   | ..   | ..   | ..  | 942  | 845  |
| " " 1.0 " .. ..                                 | ..   | ..   | ..   | ..   | ..  | ..   | 942  |

DIAMETER OF PIPE 4 INCHES.

| Length in yards .. .. .                         | 100  | 250  | 500  | 750  | 1000 | 1250 | 1500 |
|-------------------------------------------------|------|------|------|------|------|------|------|
| Quantity delivered with 0.1 inch pressure .. .. | 2160 | 1366 | 966  | 788  | 683  | 611  | 557  |
| " " 0.2 " .. ..                                 | 3054 | 1932 | 1366 | 1114 | 966  | 864  | 788  |
| " " 0.3 " .. ..                                 | ..   | 2366 | 1673 | 1366 | 1183 | 1058 | 966  |
| " " 0.4 " .. ..                                 | ..   | ..   | 1932 | 1576 | 1366 | 1222 | 1114 |
| " " 0.5 " .. ..                                 | ..   | ..   | ..   | 1761 | 1526 | 1366 | 1245 |
| " " 0.6 " .. ..                                 | ..   | ..   | ..   | 1932 | 1672 | 1496 | 1366 |
| " " 0.8 " .. ..                                 | ..   | ..   | ..   | ..   | 1932 | 1728 | 1576 |
| " " 1.0 " .. ..                                 | ..   | ..   | ..   | ..   | ..   | 1932 | 1761 |
| " " 1.5 " .. ..                                 | ..   | ..   | ..   | ..   | ..   | ..   | 2160 |

DIAMETER OF PIPE 5 INCHES.

| Length in yards .. .. .                         | 100  | 250  | 500  | 750  | 1000 | 1250 | 1500 |
|-------------------------------------------------|------|------|------|------|------|------|------|
| Quantity delivered with 0.1 inch pressure .. .. | 3540 | 2245 | 1587 | 1296 | 1122 | 1000 | 910  |
| " " 0.2 " .. ..                                 | 5005 | 3174 | 2245 | 1832 | 1587 | 1414 | 1296 |
| " " 0.3 " .. ..                                 | ..   | 3888 | 2748 | 2245 | 1943 | 1732 | 1575 |
| " " 0.4 " .. ..                                 | ..   | ..   | 3174 | 2592 | 2245 | 2000 | 1820 |
| " " 0.5 " .. ..                                 | ..   | ..   | ..   | 2888 | 2508 | 2236 | 1934 |
| " " 0.6 " .. ..                                 | ..   | ..   | ..   | ..   | 2748 | 2449 | 2245 |
| " " 0.8 " .. ..                                 | ..   | ..   | ..   | ..   | 3174 | 2828 | 2506 |
| " " 1.0 " .. ..                                 | ..   | ..   | ..   | ..   | ..   | 3174 | 2877 |
| " " 1.5 " .. ..                                 | ..   | ..   | ..   | ..   | ..   | ..   | 3540 |

DIAMETER OF PIPE 6 INCHES.

| Length in yards .. .. .                         | 250  | 500  | 750  | 1000 | 1250 | 1500 | 1750 |
|-------------------------------------------------|------|------|------|------|------|------|------|
| Quantity delivered with 0.1 inch pressure .. .. | 3770 | 2660 | 2170 | 1880 | 1680 | 1530 | 1420 |
| " " 0.2 " .. ..                                 | 5320 | 3770 | 3130 | 2660 | 2370 | 2170 | 2010 |
| " " 0.3 " .. ..                                 | 6520 | 4620 | 3770 | 3270 | 2920 | 2660 | 2460 |
| " " 0.4 " .. ..                                 | 7540 | 5320 | 4340 | 3770 | 3360 | 3060 | 2840 |
| " " 0.5 " .. ..                                 | ..   | 5970 | 4860 | 4210 | 3770 | 3430 | 3180 |
| " " 0.6 " .. ..                                 | ..   | ..   | 5320 | 4620 | 4130 | 3770 | 3460 |
| " " 0.8 " .. ..                                 | ..   | ..   | ..   | 5320 | 4740 | 4340 | 4020 |
| " " 1.0 " .. ..                                 | ..   | ..   | ..   | ..   | 5320 | 4860 | 4500 |
| " " 1.5 " .. ..                                 | ..   | ..   | ..   | ..   | ..   | 5970 | 5500 |
| " " 2.0 " .. ..                                 | ..   | ..   | ..   | ..   | ..   | ..   | 6360 |

DIAMETER OF PIPE 8 INCHES.

| Length in yards .. .. .                         | 250    | 500    | 750    | 1000   | 1250   | 1500   | 1750   |
|-------------------------------------------------|--------|--------|--------|--------|--------|--------|--------|
| Quantity delivered with 0.1 inch pressure .. .. | 7.760  | 5.470  | 4.470  | 3.880  | 3.460  | 3.160  | 2.920  |
| " " 0.2 " .. ..                                 | 10.940 | 7.760  | 6.310  | 5.470  | 4.880  | 4.470  | 4.130  |
| " " 0.3 " .. ..                                 | 13.400 | 9.450  | 7.760  | 6.700  | 5.980  | 5.470  | 5.050  |
| " " 0.4 " .. ..                                 | 15.520 | 10.940 | 8.940  | 7.760  | 6.920  | 6.320  | 5.840  |
| " " 0.5 " .. ..                                 | ..     | 12.200 | 9.900  | 8.640  | 7.760  | 7.020  | 6.520  |
| " " 0.6 " .. ..                                 | ..     | ..     | 10.940 | 9.450  | 8.480  | 7.760  | 7.150  |
| " " 0.8 " .. ..                                 | ..     | ..     | ..     | 10.940 | 9.780  | 8.940  | 8.260  |
| " " 1.0 " .. ..                                 | ..     | ..     | ..     | ..     | 10.940 | 9.900  | 9.230  |
| " " 1.5 " .. ..                                 | ..     | ..     | ..     | ..     | ..     | 12.200 | 11.300 |
| " " 2.0 " .. ..                                 | ..     | ..     | ..     | ..     | ..     | ..     | 13.040 |

DISCHARGE OF GAS IN CUBIC FEET PER HOUR, &c.—continued.

DIAMETER OF PIPE 10 INCHES.

| Length in yards                           | 500    | 750    | 1000   | 1250   | 1500   | 1750   | 2000   |
|-------------------------------------------|--------|--------|--------|--------|--------|--------|--------|
| Quantity delivered with 0·1 inch pressure | 9,560  | 7,800  | 6,750  | 6,050  | 5,520  | 5,100  | 4,780  |
| " " 0·2                                   | 13,500 | 11,040 | 9,560  | 8,520  | 7,800  | 7,300  | 6,750  |
| " " 0·3                                   | 16,500 | 13,500 | 11,700 | 10,520 | 9,560  | 8,850  | 8,250  |
| " " 0·4                                   | 19,120 | 15,600 | 13,500 | 12,100 | 11,040 | 10,200 | 9,560  |
| " " 0·5                                   | 21,300 | 17,400 | 15,050 | 13,500 | 12,380 | 11,400 | 10,650 |
| " " 0·6                                   | ..     | 19,120 | 16,500 | 14,800 | 13,500 | 12,500 | 11,650 |
| " " 0·8                                   | ..     | ..     | 19,120 | 17,050 | 15,600 | 14,400 | 13,500 |
| " " 1·0                                   | ..     | ..     | ..     | 19,120 | 17,400 | 16,150 | 15,050 |
| " " 1·5                                   | ..     | ..     | ..     | ..     | 21,300 | 19,600 | 18,500 |
| " " 2·0                                   | ..     | ..     | ..     | ..     | ..     | 22,800 | 21,800 |

DIAMETER OF PIPE 12 INCHES.

| Length in yards                           | 500    | 750    | 1000   | 1250   | 1500   | 1750   | 2000   |
|-------------------------------------------|--------|--------|--------|--------|--------|--------|--------|
| Quantity delivered with 0·1 inch pressure | 15,100 | 12,300 | 10,700 | 9,550  | 8,700  | 8,050  | 7,550  |
| " " 0·2                                   | 21,400 | 17,400 | 15,100 | 13,450 | 12,300 | 11,350 | 10,700 |
| " " 0·3                                   | 26,100 | 21,400 | 19,500 | 16,500 | 15,100 | 13,880 | 13,050 |
| " " 0·4                                   | 30,200 | 24,600 | 21,400 | 19,100 | 17,400 | 16,100 | 15,100 |
| " " 0·5                                   | 33,600 | 27,500 | 23,800 | 21,400 | 19,440 | 18,050 | 16,800 |
| " " 0·6                                   | ..     | 30,200 | 26,100 | 23,300 | 21,400 | 19,800 | 19,500 |
| " " 0·8                                   | ..     | ..     | 30,200 | 26,900 | 24,600 | 22,700 | 21,400 |
| " " 1·0                                   | ..     | ..     | ..     | 30,200 | 27,500 | 25,450 | 23,800 |
| " " 1·5                                   | ..     | ..     | ..     | ..     | 33,600 | 31,250 | 29,250 |
| " " 2·0                                   | ..     | ..     | ..     | ..     | ..     | 36,100 | 33,600 |

DIAMETER OF PIPE 14 INCHES.

| Length in yards                           | 500    | 750    | 1000   | 1250   | 1500   | 1750   | 2000   |
|-------------------------------------------|--------|--------|--------|--------|--------|--------|--------|
| Quantity delivered with 0·1 inch pressure | 22,100 | 18,100 | 15,600 | 13,950 | 12,750 | 11,800 | 11,050 |
| " " 0·2                                   | 31,200 | 25,500 | 22,100 | 19,800 | 18,100 | 16,700 | 15,600 |
| " " 0·3                                   | 38,400 | 31,200 | 27,100 | 24,250 | 22,100 | 20,500 | 19,200 |
| " " 0·4                                   | 44,200 | 36,200 | 31,200 | 27,900 | 25,500 | 23,600 | 22,100 |
| " " 0·5                                   | 49,400 | 40,400 | 35,000 | 31,200 | 28,500 | 26,460 | 24,700 |
| " " 0·6                                   | ..     | 44,200 | 38,400 | 34,300 | 31,200 | 28,900 | 27,100 |
| " " 0·8                                   | ..     | ..     | 44,200 | 39,600 | 36,200 | 33,400 | 31,200 |
| " " 1·0                                   | ..     | ..     | ..     | 44,200 | 40,400 | 37,300 | 35,000 |
| " " 1·5                                   | ..     | ..     | ..     | ..     | 49,400 | 45,700 | 42,600 |
| " " 2·0                                   | ..     | ..     | ..     | ..     | ..     | 52,920 | 49,400 |

DIAMETER OF PIPE 15 INCHES.

| Length in yards                           | 500    | 750    | 1000   | 1250   | 1500   | 1750   | 2000   |
|-------------------------------------------|--------|--------|--------|--------|--------|--------|--------|
| Quantity delivered with 0·1 inch pressure | 26,300 | 21,400 | 18,600 | 16,600 | 15,200 | 14,000 | 13,150 |
| " " 0·2                                   | 37,200 | 30,400 | 26,300 | 23,500 | 21,400 | 19,900 | 18,600 |
| " " 0·3                                   | 45,500 | 37,200 | 32,250 | 28,750 | 26,300 | 24,300 | 22,750 |
| " " 0·4                                   | 52,600 | 42,800 | 37,200 | 33,200 | 30,400 | 28,000 | 26,300 |
| " " 0·5                                   | 58,700 | 48,000 | 41,600 | 37,200 | 34,000 | 31,400 | 29,350 |
| " " 0·6                                   | ..     | 52,600 | 45,500 | 40,700 | 37,200 | 34,450 | 32,250 |
| " " 0·8                                   | ..     | ..     | 52,600 | 47,000 | 42,800 | 39,800 | 37,200 |
| " " 1·0                                   | ..     | ..     | ..     | 52,600 | 48,000 | 44,400 | 41,600 |
| " " 1·5                                   | ..     | ..     | ..     | ..     | 58,700 | 54,300 | 50,800 |
| " " 2·0                                   | ..     | ..     | ..     | ..     | ..     | ..     | 58,700 |

DIAMETER OF PIPE 16 INCHES.

| Length in yards                           | 500    | 750    | 1000   | 1250   | 1500   | 1750   | 2000   |
|-------------------------------------------|--------|--------|--------|--------|--------|--------|--------|
| Quantity delivered with 0·1 inch pressure | 31,000 | 25,250 | 21,850 | 19,550 | 17,850 | 16,550 | 15,500 |
| " " 0·2                                   | 43,700 | 35,700 | 31,000 | 27,700 | 25,250 | 23,400 | 21,850 |
| " " 0·3                                   | 53,600 | 43,700 | 38,100 | 34,000 | 31,000 | 28,700 | 26,800 |
| " " 0·4                                   | 62,000 | 50,500 | 43,700 | 39,100 | 35,700 | 33,100 | 31,000 |
| " " 0·5                                   | 69,120 | 56,600 | 49,000 | 43,700 | 39,900 | 37,150 | 34,560 |
| " " 0·6                                   | ..     | 62,000 | 53,600 | 47,900 | 43,700 | 38,100 | 40,700 |
| " " 0·8                                   | ..     | ..     | 62,000 | 55,400 | 50,500 | 46,800 | 43,700 |
| " " 1·0                                   | ..     | ..     | ..     | 62,000 | 56,600 | 52,400 | 49,000 |
| " " 1·5                                   | ..     | ..     | ..     | ..     | 69,120 | 63,900 | 60,400 |
| " " 2·0                                   | ..     | ..     | ..     | ..     | ..     | 74,300 | 69,120 |



DISCHARGE OF GAS IN CUBIC FEET PER HOUR, &C.—continued.

DIAMETER OF PIPE 18 INCHES.

| Length in yard                            | 500    | 750    | 1000   | 1500   | 2000   | 2500   | 3000   |
|-------------------------------------------|--------|--------|--------|--------|--------|--------|--------|
| Quantity delivered with 0.1 inch pressure | 41,400 | 33,800 | 29,400 | 23,900 | 20,700 | 18,400 | 16,900 |
| " " 0.2 "                                 | 58,800 | 47,800 | 41,400 | 33,800 | 29,400 | 26,200 | 23,900 |
| " " 0.3 "                                 | 71,800 | 58,800 | 50,800 | 41,400 | 35,900 | 32,100 | 29,400 |
| " " 0.4 "                                 | 82,800 | 67,600 | 58,800 | 47,800 | 41,400 | 36,800 | 33,800 |
| " " 0.5 "                                 | 92,600 | 75,700 | 65,600 | 53,500 | 46,300 | 41,400 | 37,850 |
| " " 0.6 "                                 | ..     | 82,800 | 71,800 | 58,800 | 50,800 | 45,400 | 41,400 |
| " " 0.8 "                                 | ..     | ..     | 82,800 | 67,600 | 58,800 | 52,300 | 47,500 |
| " " 1.0 "                                 | ..     | ..     | ..     | 75,700 | 65,600 | 58,800 | 53,500 |
| " " 1.5 "                                 | ..     | ..     | ..     | ..     | 80,000 | 71,800 | 65,600 |
| " " 2.0 "                                 | ..     | ..     | ..     | ..     | ..     | 82,800 | 75,700 |
| " " 2.5 "                                 | ..     | ..     | ..     | ..     | ..     | ..     | 84,500 |

DIAMETER OF PIPE 20 INCHES.

| Length in yards                           | 500     | 750     | 1000    | 1500   | 2000    | 2500    | 3000    |
|-------------------------------------------|---------|---------|---------|--------|---------|---------|---------|
| Quantity delivered with 0.1 inch pressure | 54,000  | 44,000  | 38,250  | 31,200 | 27,000  | 24,200  | 22,000  |
| " " 0.2 "                                 | 76,500  | 62,400  | 54,000  | 44,000 | 38,250  | 34,200  | 31,200  |
| " " 0.3 "                                 | 93,500  | 76,500  | 66,100  | 54,000 | 46,750  | 41,800  | 38,250  |
| " " 0.4 "                                 | 108,000 | 88,000  | 76,500  | 62,400 | 54,000  | 48,400  | 44,000  |
| " " 0.5 "                                 | 120,500 | 98,800  | 85,300  | 69,800 | 62,250  | 54,000  | 49,400  |
| " " 0.6 "                                 | ..      | 108,000 | 93,500  | 76,500 | 66,100  | 59,100  | 54,000  |
| " " 0.8 "                                 | ..      | ..      | 108,000 | 88,000 | 76,500  | 68,400  | 62,400  |
| " " 1.0 "                                 | ..      | ..      | ..      | 98,800 | 85,300  | 76,500  | 69,800  |
| " " 1.5 "                                 | ..      | ..      | ..      | ..     | 102,300 | 93,500  | 85,300  |
| " " 2.0 "                                 | ..      | ..      | ..      | ..     | ..      | 108,000 | 98,800  |
| " " 2.5 "                                 | ..      | ..      | ..      | ..     | ..      | ..      | 110,200 |

DIAMETER OF PIPE 22 INCHES.

| Length in yards                           | 500     | 750     | 1000    | 1500    | 2000    | 2500    | 3000    |
|-------------------------------------------|---------|---------|---------|---------|---------|---------|---------|
| Quantity delivered with 0.1 inch pressure | 68,600  | 56,000  | 48,400  | 29,600  | 34,300  | 30,700  | 28,000  |
| " " 0.2 "                                 | 96,800  | 79,200  | 68,600  | 56,000  | 48,400  | 43,400  | 39,600  |
| " " 0.3 "                                 | 118,800 | 96,800  | 84,000  | 68,600  | 59,400  | 53,300  | 48,400  |
| " " 0.4 "                                 | 137,200 | 112,000 | 96,800  | 79,200  | 68,600  | 61,400  | 56,000  |
| " " 0.5 "                                 | 153,500 | 122,500 | 108,200 | 88,600  | 76,800  | 68,400  | 61,200  |
| " " 0.6 "                                 | ..      | 137,200 | 118,800 | 96,800  | 84,000  | 75,000  | 68,600  |
| " " 0.8 "                                 | ..      | ..      | 137,200 | 112,000 | 96,800  | 86,500  | 79,200  |
| " " 1.0 "                                 | ..      | ..      | ..      | 122,500 | 108,200 | 96,800  | 88,600  |
| " " 1.5 "                                 | ..      | ..      | ..      | ..      | 132,000 | 118,800 | 108,200 |
| " " 2.0 "                                 | ..      | ..      | ..      | ..      | ..      | 137,200 | 122,500 |
| " " 2.5 "                                 | ..      | ..      | ..      | ..      | ..      | ..      | 140,000 |

DIAMETER OF PIPE 24 INCHES.

| Length in yards                           | 500     | 750     | 1000    | 1500    | 2000    | 2500    | 3000    |
|-------------------------------------------|---------|---------|---------|---------|---------|---------|---------|
| Quantity delivered with 0.1 inch pressure | 84,000  | 68,600  | 59,500  | 48,500  | 42,000  | 37,500  | 34,300  |
| " " 0.2 "                                 | 119,000 | 97,000  | 84,000  | 68,600  | 59,000  | 53,400  | 48,500  |
| " " 0.3 "                                 | 145,500 | 119,000 | 103,000 | 84,000  | 72,700  | 65,200  | 59,500  |
| " " 0.4 "                                 | 168,000 | 137,200 | 119,000 | 97,000  | 84,000  | 75,000  | 68,600  |
| " " 0.5 "                                 | 187,500 | 155,000 | 135,600 | 108,600 | 93,800  | 84,000  | 77,500  |
| " " 0.6 "                                 | ..      | 168,000 | 145,000 | 119,000 | 103,000 | 92,000  | 84,000  |
| " " 0.8 "                                 | ..      | ..      | 168,000 | 137,200 | 119,000 | 106,000 | 97,000  |
| " " 1.0 "                                 | ..      | ..      | ..      | 155,000 | 135,600 | 119,000 | 108,600 |
| " " 1.5 "                                 | ..      | ..      | ..      | ..      | 163,000 | 145,500 | 135,600 |
| " " 2.0 "                                 | ..      | ..      | ..      | ..      | ..      | 168,000 | 155,000 |
| " " 2.5 "                                 | ..      | ..      | ..      | ..      | ..      | ..      | 172,000 |

DIAMETER OF PIPE 26 INCHES.

| Length in yards                           | 750     | 1000    | 1500    | 2000    | 2500    | 3000    | 4000    |
|-------------------------------------------|---------|---------|---------|---------|---------|---------|---------|
| Quantity delivered with 0.1 inch pressure | 85,000  | 73,500  | 60,000  | 52,000  | 46,500  | 42,500  | 36,750  |
| " " 0.2 "                                 | 120,000 | 104,000 | 85,000  | 73,500  | 65,800  | 60,000  | 52,000  |
| " " 0.3 "                                 | 147,000 | 127,000 | 104,000 | 90,000  | 80,600  | 73,500  | 63,500  |
| " " 0.4 "                                 | 170,000 | 147,000 | 120,000 | 104,000 | 93,000  | 85,000  | 73,500  |
| " " 0.5 "                                 | 189,000 | 165,000 | 134,000 | 116,000 | 104,000 | 94,500  | 82,500  |
| " " 0.6 "                                 | 208,000 | 180,000 | 147,000 | 127,000 | 114,000 | 104,000 | 90,000  |
| " " 0.8 "                                 | ..      | 208,000 | 170,000 | 147,000 | 132,000 | 120,000 | 104,000 |
| " " 1.0 "                                 | ..      | ..      | 189,000 | 165,000 | 147,000 | 134,000 | 116,000 |
| " " 1.5 "                                 | ..      | ..      | ..      | 201,000 | 180,000 | 165,000 | 142,000 |
| " " 2.0 "                                 | ..      | ..      | ..      | ..      | 208,000 | 189,000 | 165,000 |
| " " 2.5 "                                 | ..      | ..      | ..      | ..      | ..      | 213,000 | 184,000 |
| " " 3.0 "                                 | ..      | ..      | ..      | ..      | ..      | ..      | 201,000 |

SPECIFICATIONS OF APPARATUS FOR VILLAGES, TOWNS AND CITIES—*continued.*

| <i>No. 12b Apparatus</i><br><i>For the manufacture and supply of 30,000,000 cubic feet of coal gas per annum.</i>                                                                                                                                                                                                                                                                                                                                                                                                                                                   |                                                                                                                                                                                                                                                                                                                                                                                                                                                                                                                                                                                                                                                                                                                                                                                                                                                                                                                                                                                                                                                                                                                                                                                                                                                                                                                       |
|---------------------------------------------------------------------------------------------------------------------------------------------------------------------------------------------------------------------------------------------------------------------------------------------------------------------------------------------------------------------------------------------------------------------------------------------------------------------------------------------------------------------------------------------------------------------|-----------------------------------------------------------------------------------------------------------------------------------------------------------------------------------------------------------------------------------------------------------------------------------------------------------------------------------------------------------------------------------------------------------------------------------------------------------------------------------------------------------------------------------------------------------------------------------------------------------------------------------------------------------------------------------------------------------------------------------------------------------------------------------------------------------------------------------------------------------------------------------------------------------------------------------------------------------------------------------------------------------------------------------------------------------------------------------------------------------------------------------------------------------------------------------------------------------------------------------------------------------------------------------------------------------------------|
| <b>RETORT STACK</b>                                                                                                                                                                                                                                                                                                                                                                                                                                                                                                                                                 | Ten evaporating pans, 30 furnace bars, 10 dead plates, 10 bearing bars, 10 furnace frames with double doors, 40 shield tiles for furnace doors, 100 sight boxes and covers, 20 pilasters, 10 tie bolts, 20 holding plates for furnace door frames and 40 bolts, 10 damper tiles with wrought iron rods. 35 fire clay $\square$ shaped Retorts each 16 feet long by 17 in. wide by 13 in. deep inside measures, 70 mouthpieces and 100 covers for ditto; 420 $\frac{1}{2}$ -in. T headed bolts for mouthpieces; 70 pairs of wrought iron ears, 70 cross-bars, and 70 square-threaded T screws; 70 5-in. saddle flange pipes and bolts; 70 ascension pipes 5 in. to 4 in. bore; 70 4-in. N pipes with cleaning plugs, 70 4-in. dip pipes and bolts; 2 Hydraulic Mains each 16 in. diameter of bore, and of sufficient length to receive the dip pipes from 35 mouthpieces with ends and bolts, 1 10-in. pipe for connecting, and 12 crutched pillars to support the Hydraulic Mains.                                                                                                                                                                                                                                                                                                                                    |
| <b>CONDENSERS</b>                                                                                                                                                                                                                                                                                                                                                                                                                                                                                                                                                   | One AIR CONDENSER, on the Annular principle, consisting of 12 outer tubes each of 21 in. external diameter and 12 ft. high, with flange at each end, and 12 inner tubes each of 12 in. external diameter and 15 ft. high with flange at each end; 2 top boxes each in 3 parts, and 2 bottom boxes each in 4 parts, with cleaning doors and bolts; 8 4-in. T pipes with cleaning caps and bolts, 2 10-in. T pipes with cleaning caps and bolts for inlet to condenser, 2 10-in. bends with cleaning caps and bolts for outlet from condenser, 2 dip cisterns each 18 in. by 18 in. by 21 in. deep; each internal tube to be provided with a damper plate for controlling the current of air. To provide 1 10-in. sixway rising plug valve; arranged for passing the gas through both divisions of condenser in succession, or for by-passing either division.                                                                                                                                                                                                                                                                                                                                                                                                                                                          |
| <b>SCRUBBERS</b>                                                                                                                                                                                                                                                                                                                                                                                                                                                                                                                                                    | Two COKE OR BREEZE SCRUBBERS, each 5 ft. diameter by 12 ft. high, fitted with 2 tiers of cast iron grids, with wrought iron T bearers for supporting ditto, 3 filling and discharging doors and frames, with wrought iron ears, cross-bars, T screws and bolts; 1 water distributing apparatus with main cock and key; each scrubber to have also a base plate and cap, 2 10-in. T pipes with cleaning caps and bolts for inlet and outlet, and 2 dip cisterns each 18 in. by 18 in. by 21 in. deep. To provide 1 10-in. sixway rising plug valve arranged to pass the gas through both scrubbers at once, or to by-pass one or both scrubbers as required.                                                                                                                                                                                                                                                                                                                                                                                                                                                                                                                                                                                                                                                           |
| <b>EXHAUSTERS</b>                                                                                                                                                                                                                                                                                                                                                                                                                                                                                                                                                   | One EXHAUSTING APPARATUS in duplicate, each part to be capable of passing 10,000 cubic feet of gas per hour, with steam engines, boilers, gearing, framework, fittings, steam and exhaust pipes, feed pumps and pipes, fly-wheels, shafts, plummer blocks, governors, throttle valves and stop valves complete; the exhausters, engines and boilers to be so arranged that either exhauster, engine or boiler can be shut off, or either exhauster can be worked by either engine as required. One governor with gearing and valve placed on the gas supply pipe, 1 self-acting by-pass valve, 1 10-in. sixway rising plug valve, arranged to pass the gas through both exhausters at once, or to by-pass either one or both exhausters.                                                                                                                                                                                                                                                                                                                                                                                                                                                                                                                                                                              |
| <b>PURIFIERS</b>                                                                                                                                                                                                                                                                                                                                                                                                                                                                                                                                                    | Four dry lime PURIFIERS, each 10 ft. $\times$ 10 ft. $\times$ 3 ft. 6 in. deep, and fitted with 4 tiers of wood sieves or grids resting on ledges cast on the sides of purifiers, and on wrought-iron T bearers, water lutes with wrought-iron turn-buckles, wrought-iron covers with ground air plugs and frames, and books for lifting; 4 covers for inlet pipes; 2 lifting carriages and chain slings for removing and replacing covers of purifiers, 4 wrought iron lattice girders for carrying lifting carriages and covers. To provide 1 10-in. centre change valve for passing the gas through any three of the purifiers in succession, or through all four purifiers in succession as required.                                                                                                                                                                                                                                                                                                                                                                                                                                                                                                                                                                                                             |
| <b>STATION METER</b>                                                                                                                                                                                                                                                                                                                                                                                                                                                                                                                                                | One STATION METER, capable of registering 10,000 cubic ft. of gas per hour, fitted with pressure and water gauges, tell tale, indices, filling plug, etc. To provide 1 10-in. fourway, by-pass, and shut-off rising plug valve, to act as by-pass to station meter.                                                                                                                                                                                                                                                                                                                                                                                                                                                                                                                                                                                                                                                                                                                                                                                                                                                                                                                                                                                                                                                   |
| <b>GASHOLDER</b>                                                                                                                                                                                                                                                                                                                                                                                                                                                                                                                                                    | Two GASHOLDERS, 70 ft. diameter by 20 ft. deep at the sides, and containing 77,000 cubic feet; the sheets forming the crowns to be of No. 14 Birmingham wire gauge thickness, excepting the outer rows of sheets, which are to be of No. 12 Birmingham wire gauge thickness; the sheets forming the sides to be of No. 14 Birmingham wire gauge thickness, excepting the top and bottom rows of sheets which are to be of No. 12 Birmingham wire gauge thickness; to have strong and suitable internal framework. To provide for each gas-holder, 7 cast iron guide columns each 21 feet high; 7 wrought iron lattice girders, with bolts and cast iron sockets for securing to tops of columns; 7 tops or caps for columns and bolts; 21 foundation bolts and 7 foundation plates; 7 guide pulleys with carriages, adjusting plates, axles and bolts for top of sides, and 14 guide rollers with carriages, axles, and bolts for bottom of sides of Gasholder.                                                                                                                                                                                                                                                                                                                                                       |
| <b>GOVERNORS</b>                                                                                                                                                                                                                                                                                                                                                                                                                                                                                                                                                    | One STATION GOVERNOR, fitted complete: 1 12-in. fourway, by-pass, and shut-off rising plug valve to act as by-pass to governor.                                                                                                                                                                                                                                                                                                                                                                                                                                                                                                                                                                                                                                                                                                                                                                                                                                                                                                                                                                                                                                                                                                                                                                                       |
| <b>CONNECTIONS, ETC.</b>                                                                                                                                                                                                                                                                                                                                                                                                                                                                                                                                            | All the necessary 10-in. pipe, not exceeding 150 yds. with bends and T pieces, for connecting the Hydraulic Main, condensers, scrubbers, exhausters, purifiers, station meter, and gasholder, and 80 yards of 12-in. pipe with bends and T pieces for connecting both the gasholders and governor, also 50 yards of 4-in. pipe for connecting the tarpit cisterns and from thence to tar well; 2 10-in. and 2 12-in. tank syphons, 3 10-in. and 2 12-in. through way rising plug valves, for inlet and outlet to both gasholders, and by-pass; 4 $\frac{1}{2}$ -in. wrought iron suction pipes.                                                                                                                                                                                                                                                                                                                                                                                                                                                                                                                                                                                                                                                                                                                       |
| <b>SUNDRIES</b>                                                                                                                                                                                                                                                                                                                                                                                                                                                                                                                                                     | One set of gearing and framework, 2 3-in. lift and force pumps for water, arranged to be worked either by hand or by power, with suction and delivery pipes to cistern, bends and connections; 1 wrought iron cistern to contain 750 gallons; supply pipes and connections from cistern to retort house, purifier house, and scrubbers, with 6 draw-off cocks, and 2 brass main cocks for ditto; 1 supply pipe with bends and connections, and 2 brass main cocks, and 12 feed pipes from water cistern to condensers, 1 supply pipe with bends and connections, and 2 brass main cocks, from water cistern to feed pumps. To provide 1 set of gearing and framework, and 2 4-in. suction pumps, one for tar and one for ammoniacal liquor, arranged to be worked either by hand or by power, with 3 in. pipe into tar well, 2 10-in. drain grates and frames. To provide for various parts of the apparatus, 7 pressure gauges with service pipes, bends and connections, 1 vacuum gauge with service pipe, bends, cocks and connections, for exhausters, 1 registering pressure gauge, with service pipe, bends and connections, 4 test cocks with service pipes, bends and connections. To provide the necessary pipe and fittings for gas-lights in the retort house, engine and boiler houses, yard and offices. |
| <b>TOOLS</b>                                                                                                                                                                                                                                                                                                                                                                                                                                                                                                                                                        | Four sets of stoking tools, 4 firing shovels, 4 charging shovels, 8 charging scoops with carrying bars and stands, 2 iron coke waggons, 2 iron coal waggons, 2 weighing machines, one for coal and one for coke, with weights, 4 galvanised iron cisterns for water for retort house, each to hold 30 gallons, 6 galvanised iron pails, 4 2-gallon water pots, 4 pairs of sight hole tongs, 4 augers for ascension pipes, 4 trowels, 6 coal hammers, 4 retort lid scrapers, 2 coal shovels, 2 coke shovels, 4 lime shovels, 4 sieves for lime, 2 brass syphon pumps. To provide all bolts, pins, rivets, cement, lead, yarn, red and white lead, paint and oil, requisite to fix the above, and to give the whole one coat of metallic oxide paint after completion.<br>250 tons.                                                                                                                                                                                                                                                                                                                                                                                                                                                                                                                                     |
| <p>Total Dead Weight of Ironwork.<br/>Measurement in cubic feet additional.<br/>Export Price delivered at the Docks<br/>in London, Liverpool, or Hull, in-<br/>clusive of packing and Cases.<br/>Home Price delivered at St. Neots Sta-<br/>tion, and erected complete in England,<br/>exclusive of buildings, foundations,<br/>brick or woodwork, or scaffolding.<br/>Quantity of Firebricks, etc., required<br/>to set Retorts.</p> <p>Weight of Firebricks, etc.<br/>Price of Firebricks, etc., delivered at<br/>the Docks in London, Liverpool or<br/>Hull.</p> | <p>21,000 square and 4000 arch bricks, 90 lumps 23 in. <math>\times</math> 9 in. <math>\times</math> 4 <math>\frac{1}{2}</math> in. 90 lumps 9 in. <math>\times</math> 9 in. <math>\times</math> 4 <math>\frac{1}{2}</math> in., 90 lumps 6 in. <math>\times</math> 4 <math>\frac{1}{2}</math> in. <math>\times</math> 6 in. <math>\times</math> 4 <math>\frac{1}{2}</math> in., 90 lumps, 4 in. <math>\times</math> 4 <math>\frac{1}{2}</math> in. <math>\times</math> 4 <math>\frac{1}{2}</math> in., 45 lumps 10 in. <math>\times</math> 6 in. <math>\times</math> 4 <math>\frac{1}{2}</math> in., 90 tiles 18 in. <math>\times</math> 12 in. <math>\times</math> 3 in., and 15 tons of fireclay.<br/>106 tons.</p>                                                                                                                                                                                                                                                                                                                                                                                                                                                                                                                                                                                                |

SPECIFICATION OF APPARATUS FOR THE MANUFACTURE OF GAS FROM OILS, PETROLEUM, NAPHTHA, ETC.

|                                                                                                                                                               | <i>No. 1c Apparatus</i><br><i>To manufacture for, and supply with gas from Oils, Petroleum, Naphtha, etc., 100 burners for 6 hours, or 50 burners for 12 hours per day, each burner giving a light equal to 10 sperm candles.</i>                                                                                                                                                                                                                                                                                                                                                                                                                                                                                                                                                                                                                                                                                                                                                                                                                                                          | <i>No. 2c Apparatus</i><br><i>To manufacture for, and supply with gas from Oils, Petroleum, Naphtha, etc., 300 burners for 6 hours, or 150 burners for 12 hours per day, each burner giving a light equal to 10 sperm candles.</i>                                                                                                                                                                                                                                                                                                                                                                                                                                                                                                                                                                                                                                                                                                                                                                                                                                                                                                                                                                                                                                                                                                        |
|---------------------------------------------------------------------------------------------------------------------------------------------------------------|--------------------------------------------------------------------------------------------------------------------------------------------------------------------------------------------------------------------------------------------------------------------------------------------------------------------------------------------------------------------------------------------------------------------------------------------------------------------------------------------------------------------------------------------------------------------------------------------------------------------------------------------------------------------------------------------------------------------------------------------------------------------------------------------------------------------------------------------------------------------------------------------------------------------------------------------------------------------------------------------------------------------------------------------------------------------------------------------|-------------------------------------------------------------------------------------------------------------------------------------------------------------------------------------------------------------------------------------------------------------------------------------------------------------------------------------------------------------------------------------------------------------------------------------------------------------------------------------------------------------------------------------------------------------------------------------------------------------------------------------------------------------------------------------------------------------------------------------------------------------------------------------------------------------------------------------------------------------------------------------------------------------------------------------------------------------------------------------------------------------------------------------------------------------------------------------------------------------------------------------------------------------------------------------------------------------------------------------------------------------------------------------------------------------------------------------------|
| <b>RETORT STACK</b>                                                                                                                                           | Two DIAPHRAGM RETORTS, each Retort to be capable of producing 40 cubic feet of gas per hour, and to be each fitted with mouthpieces, 2 covers, gearing for opening and closing, and bolts. To provide 2 cast iron cases for receiving Retorts, fitted complete with doors, fire bars and frames, dampers and 30 feet of sheet iron smoke pipe. To provide for feeding the Retorts with oils, etc., and water, 2 feed pipes, 4 syphons and funnels, one feed cistern 20 in. long X 10 in. wide X 15 in. deep; 1 feed cistern 20 in. long X 6 in. wide X 12 in. deep, 2 Patent Syphon Floats for maintaining an unvarying flow of liquid, fitted with 4 feed cocks and pipes. To provide 2 3-in. ascension pipes, 2 3-in. N shaped pipes with cleaning plugs, 2 3-in. dip pipes and bolts. To provide one Hydraulic Main constructed with Self-Acting Arrangement for removing the dip when the Retorts are in work, and replacing it when the doors are removed; provided with dip cistern, overflow pipes, holder, tank, gearing, cocks, and piping, 2 crutches to support Hydraulic Main. | Two DIAPHRAGM Retorts, each Retort to be capable of producing 80 cubic feet of gas per hour, and to be each fitted with mouthpiece, 2 covers, gearing for opening and closing, and bolts. To provide 2 furnaces for heating Retorts, consisting of 2 evaporating pans, 6 furnace bars, 2 bearers, 2 dead plates, 2 doors and frames fitted, 6 sight boxes and covers, 2 damper tiles with wrought iron rods and bolts, 4 shield tiles for furnace doors; also, 10 pilasters, 4 dwarf pilasters, 2 cross girders and bolts, and 5 tie bolts for bracing the brickwork together. To provide for feeding the Retorts with naphtha and water, 2 feed pipes, 4 syphons and funnels, 1 feed cistern 3 ft. 3 in. long X 10 in. wide X 20 in. deep; 1 feed cistern 3 ft. 3 in. long X 10 in. wide X 12 in. deep, 2 Patent Syphon Floats for maintaining an unvarying flow of liquid, fitted with 4 feed cocks and pipes. To provide 2 4-in. ascension pipes, 2 4-in. N shaped pipes fitted with cleaning plugs, 2 4-in. dip pipes and bolts. To provide 1 Hydraulic Main 4 ft. 6 in. long, constructed with Self-Acting Arrangement for removing the dip when the Retorts are in work, and replacing it when the door is removed; provided with dip cistern, overflow pipes, holder, tank, gearing, cocks and piping, 2 crutches to support Main. |
| <b>CONDENSER, ETC.</b>                                                                                                                                        | One PATENT COMBINED CONDENSING AND WASHING VESSELS, 4 ft. X 4 ft. X 12 in. deep, 2 dip cisterns, inlet and outlet pipes and bolts.                                                                                                                                                                                                                                                                                                                                                                                                                                                                                                                                                                                                                                                                                                                                                                                                                                                                                                                                                         | Two PATENT COMBINED CONDENSING AND WASHING VESSELS, each 4 ft. X 4 ft. X 12 in. deep, 2 dip cisterns, inlet and outlet pipes and bolts; also cast iron frames and bolts for supporting the upper boxes.                                                                                                                                                                                                                                                                                                                                                                                                                                                                                                                                                                                                                                                                                                                                                                                                                                                                                                                                                                                                                                                                                                                                   |
| <b>GASHOLDER</b>                                                                                                                                              | One GASHOLDER, 10 ft. diameter X 6 ft. deep at the sides, containing 470 cubic feet; the sheets forming the crown and sides to be of No. 16 Birmingham wire gauge thickness, with strong and suitable internal framework; 3 guide columns each 7 ft. 6 in. high, 3 wrought iron girders and bolts to connect the tops of columns, 9 foundation bolts and 3 plates; 3 sets of chain slings, pulleys, carriages, axles, balance weights and bolts; 3 guide pulleys with carriages, adjusting plates, axles and bolts for top of sides, and 6 guide rollers with carriages, axles and bolts for bottom of sides of Gasholder.                                                                                                                                                                                                                                                                                                                                                                                                                                                                 | One GASHOLDER, 14 ft. deep in diameter X 8 ft. deep at the sides, containing 1,250 cubic feet; the sheets forming the crown and sides to be of No. 16 Birmingham Wire Gauge thickness, with strong and suitable internal framework; 3 guide columns each 9 feet high, 3 wrought iron girders and bolts to connect the tops of columns, 9 foundation bolts and 3 plates; 3 sets of chain slings, pulleys, carriages, axles, balance weights and bolts; 3 guide pulleys with carriages, adjusting plates, axles and bolts for top of sides, and 6 guide rollers with carriages, axles and bolts for bottom of sides of Gasholder.                                                                                                                                                                                                                                                                                                                                                                                                                                                                                                                                                                                                                                                                                                           |
| <b>SUNDRIES</b>                                                                                                                                               | The necessary 2 in. connecting pipe, not exceeding 18 yards from the Hydraulic Main to condenser, into and out of Gasholder to outlet valve, and to tar well, 2 2-in. valves for inlet and outlet to Gasholder, 2 tank syphons; 2 3/4-in. suction pipes, 1 brass syphon pump, 1 set of stoking tools. All bolts, pins, rivets, cement, lead, yarn, red and white lead, paint and oil, requisite to fix the above, and to give the whole one coat of paint after completion. The various parts to be plainly and legibly marked for fixing, and all parts liable to injury or loss in transit to be packed in strong and suitable cases.                                                                                                                                                                                                                                                                                                                                                                                                                                                    | Seven yards of 3-in. connecting pipe from the Hydraulic Main to condensers, and 20 yards of 2-in. connecting pipe from condensers in and out of gasholder to outlet valve, and to tar well; 2 2-in. valves for inlet and outlet to Gasholder, 2 tank syphons, 2 3/4-in. suction pipes, 1 brass syhon pump, 1 set of stoking tools. All bolts, pins, rivets, cement, lead, yarn, red and white lead, paint and oil, requisite to fix the above, and to give the whole one coat of paint after completion. The various parts to be plainly and legibly marked for fixing, and all parts liable to injury or loss in transit to be packed in strong and suitable cases.                                                                                                                                                                                                                                                                                                                                                                                                                                                                                                                                                                                                                                                                      |
| <b>Total Dead Weight of Iron-work.</b>                                                                                                                        | 4 1/4 tons.                                                                                                                                                                                                                                                                                                                                                                                                                                                                                                                                                                                                                                                                                                                                                                                                                                                                                                                                                                                                                                                                                | 7 tons.                                                                                                                                                                                                                                                                                                                                                                                                                                                                                                                                                                                                                                                                                                                                                                                                                                                                                                                                                                                                                                                                                                                                                                                                                                                                                                                                   |
| <b>Export Price delivered at the Docks in London, Liverpool, or Hull.</b>                                                                                     |                                                                                                                                                                                                                                                                                                                                                                                                                                                                                                                                                                                                                                                                                                                                                                                                                                                                                                                                                                                                                                                                                            |                                                                                                                                                                                                                                                                                                                                                                                                                                                                                                                                                                                                                                                                                                                                                                                                                                                                                                                                                                                                                                                                                                                                                                                                                                                                                                                                           |
| <b>Home Price delivered at St. Neots Station, and erected complete in England, exclusive of buildings, foundations, brickwork, wood-work, or scaffolding.</b> |                                                                                                                                                                                                                                                                                                                                                                                                                                                                                                                                                                                                                                                                                                                                                                                                                                                                                                                                                                                                                                                                                            |                                                                                                                                                                                                                                                                                                                                                                                                                                                                                                                                                                                                                                                                                                                                                                                                                                                                                                                                                                                                                                                                                                                                                                                                                                                                                                                                           |

DISCHARGE OF GAS IN CUBIC FEET PER HOUR, &c.—continued.

DIAMETER OF PIPE 28 INCHES.

| Length in yards                           |     | 1000    | 1500    | 2000    | 2500    | 3000    | 4000    | 5000    |
|-------------------------------------------|-----|---------|---------|---------|---------|---------|---------|---------|
| Quantity delivered with 0.5 inch pressure |     | 198,000 | 161,000 | 140,000 | 125,000 | 114,500 | 99,000  | 88,600  |
| "                                         | 1.0 | 280,000 | 229,000 | 198,000 | 177,000 | 161,000 | 140,000 | 125,000 |
| "                                         | 1.5 | ..      | 280,000 | 241,000 | 216,000 | 198,000 | 171,000 | 153,500 |
| "                                         | 2.0 | ..      | ..      | 280,000 | 250,000 | 229,000 | 198,000 | 177,200 |
| "                                         | 2.5 | ..      | ..      | ..      | 280,000 | 255,000 | 222,000 | 198,000 |
| "                                         | 3.0 | ..      | ..      | ..      | ..      | 280,000 | 241,000 | 216,000 |

DIAMETER OF PIPE 30 INCHES.

| Length in yards                           |     | 1000    | 2000    | 3000    | 4000    | 5000    | 7500    | 10,000  |
|-------------------------------------------|-----|---------|---------|---------|---------|---------|---------|---------|
| Quantity delivered with 0.5 inch pressure |     | 234,000 | 166,000 | 135,000 | 117,000 | 105,000 | 86,000  | 74,500  |
| "                                         | 1.0 | 332,000 | 234,000 | 192,000 | 166,000 | 149,000 | 121,500 | 105,000 |
| "                                         | 1.5 | ..      | 287,000 | 234,000 | 203,000 | 182,000 | 149,000 | 128,500 |
| "                                         | 2.0 | ..      | ..      | 270,000 | 234,000 | 210,000 | 172,000 | 149,000 |
| "                                         | 2.5 | ..      | ..      | ..      | 263,000 | 234,000 | 192,000 | 166,000 |
| "                                         | 3.0 | ..      | ..      | ..      | ..      | 257,000 | 210,000 | 182,000 |
| "                                         | 4.0 | ..      | ..      | ..      | ..      | ..      | 243,000 | 210,000 |

DIAMETER OF PIPE 36 INCHES.

| Length in yards                           |     | 1000    | 2000    | 3000    | 4000    | 5000    | 7500    | 10,000  |
|-------------------------------------------|-----|---------|---------|---------|---------|---------|---------|---------|
| Quantity delivered with 1.0 inch pressure |     | 530,000 | 372,000 | 303,000 | 265,000 | 234,000 | 192,000 | 166,000 |
| "                                         | 1.5 | ..      | 456,000 | 372,000 | 322,000 | 288,000 | 234,000 | 204,000 |
| "                                         | 2.0 | ..      | ..      | 428,000 | 372,000 | 332,000 | 271,000 | 234,000 |
| "                                         | 2.5 | ..      | ..      | ..      | 416,000 | 372,000 | 303,000 | 265,000 |
| "                                         | 3.0 | ..      | ..      | ..      | ..      | 407,000 | 332,000 | 288,000 |
| "                                         | 4.0 | ..      | ..      | ..      | ..      | ..      | 384,000 | 332,000 |

DISCHARGE OF GAS THROUGH MAINS.

The Tables on pages 104—108 are calculated upon the basis of the specific gravity of the gas being .400. The quantities of gas discharged of any other specific gravity may be ascertained by multiplying the quantities indicated in the table by .6325 (the square root of .400) and dividing the product by the square root of the specific gravity of the other gas. To facilitate these calculations, a table is annexed of the square roots of specific gravities from .350 to .700, rising .005 at each step.

Example.—If a 12-inch pipe 1000 yards long discharges 23,800 feet of gas per hour, specific gravity .400, with 0.5 inch pressure, how much will the same pipe discharge of gas, when the specific gravity is .560, with the same loss of pressure?

$$\frac{23,800 \times .6325}{.7483} = 20,116 \text{—Answer.}$$

The tables are also susceptible of being extended to longer and shorter lengths, and to higher pressures, by the application of the following axioms:—

1. The discharge of gas will be doubled when the length of the pipe is only one-fourth of any of the lengths given in the table.
2. The discharge of gas will be only one-half when the length of the pipe is four times greater than the lengths given in the table.
3. The discharge of gas is doubled by the application of four times the pressure.

TABLE OF SQUARE ROOTS OF THE SPECIFIC GRAVITY OF GAS, FROM .350 to .700.

|      |       |      |       |      |       |      |       |      |       |      |       |      |       |      |       |
|------|-------|------|-------|------|-------|------|-------|------|-------|------|-------|------|-------|------|-------|
| .350 | .5116 | .395 | .6285 | .440 | .6633 | .485 | .6964 | .530 | .7280 | .575 | .7583 | .620 | .7874 | .665 | .8155 |
| .355 | .5558 | .400 | .6325 | .445 | .6671 | .490 | .7000 | .535 | .7314 | .580 | .7616 | .625 | .7995 | .670 | .8185 |
| .360 | .6000 | .405 | .6364 | .450 | .6708 | .495 | .7035 | .540 | .7348 | .585 | .7648 | .630 | .7937 | .675 | .8216 |
| .365 | .6041 | .410 | .6403 | .455 | .6745 | .500 | .7071 | .545 | .7382 | .590 | .7681 | .635 | .7969 | .680 | .8246 |
| .370 | .6083 | .415 | .6442 | .460 | .6782 | .505 | .7106 | .550 | .7416 | .595 | .7713 | .640 | .8000 | .685 | .8276 |
| .375 | .6124 | .420 | .6481 | .465 | .6819 | .510 | .7141 | .555 | .7449 | .600 | .7746 | .645 | .8031 | .690 | .8306 |
| .380 | .6164 | .425 | .6519 | .470 | .6856 | .515 | .7176 | .560 | .7483 | .605 | .7778 | .650 | .8062 | .695 | .8337 |
| .385 | .6205 | .430 | .6557 | .475 | .6892 | .520 | .7212 | .565 | .7517 | .610 | .7810 | .655 | .8093 | .700 | .8367 |
| .390 | .6245 | .435 | .6595 | .480 | .6928 | .525 | .7246 | .570 | .7549 | .615 | .7842 | .660 | .8124 |      |       |

TABLE OF SQUARE ROOTS OF PRESSURES, RISING BY TENTHS OF AN INCH, FROM ONE-TENTH TO THREE INCHES.

| tenths | square root | tenths | square root | tenths | square root | tenths | square root |
|--------|-------------|--------|-------------|--------|-------------|--------|-------------|
| 1      | .3162       | 8      | .8944       | 16     | 1.2649      | 24     | 1.5491      |
| 2      | .4472       | 9      | .9487       | 17     | 1.3038      | 25     | 1.5811      |
| 3      | .5477       | 10     | 1.0         | 18     | 1.3416      | 26     | 1.6123      |
| 4      | .6324       | 11     | 1.0488      | 19     | 1.3784      | 27     | 1.6431      |
| 5      | .7071       | 12     | 1.0954      | 20     | 1.4142      | 28     | 1.6733      |
| 6      | .7745       | 13     | 1.1401      | 21     | 1.4491      | 29     | 1.7029      |
| 7      | .8366       | 14     | 1.1832      | 22     | 1.4832      | 30     | 1.7320      |
|        |             | 15     | 1.2251      | 23     | 1.5165      |        |             |

DIFFUSION OF GASES.

"If two bottles are filled with two gases of different specific gravities, and connected together, one bottle being superposed on the other (that containing the heaviest gas being the lowest), and allowed to stand for a few hours, they will be found to mix; the lighter gas finding its way to the lower bottle, and the heavy gas ascending to the bottle which is above. In this process the gases evince a positively active power of penetrating into the spaces occupied by each other, and this occurs even when they are separated by membranes, or by masses of porous, earthy substances.

"When gases of unequal densities are placed in contact with each other, they tend to mix alternately in an uniform manner; but the rapidity with which they penetrate each other's volume, or, as it is termed by Graham, the velocity of diffusion of the gases is unequal, and depends upon their densities; the lighter gases diffusing themselves most rapidly, and the heavier more slowly. Thus, if a tube be closed at the top by a plug of plaster of Paris (which when dry is very porous), and filled with hydrogen gas, the lower part of the tube being sealed with water and the plug kept dry, the hydrogen and the external air tend to mix through the porous substance; but the hydrogen comes out more rapidly than the air gets in, and hence the water rises considerably in the tube. In a similar way, if a glass be filled with hydrogen gas, and the top being closed by a sheet of india-rubber, a bell glass of air being inverted over it, the hydrogen passing out of the glass more rapidly than air enters to supply its place, the sheet of india-rubber is gradually bent into the glass, and ultimately bursts by the external pressure. On the contrary, if the small glass contain air, and the bell glass hydrogen, the membranous cover is gradually forced upwards by means of the excess of hydrogen which passes in, and which finally breaks through it by the elasticity thus produced inside.

"The exact law of the diffusion of gases is, that the velocity of the diffusion is inversely proportional to the square roots of the specific gravity of the gases. This is exhibited in the following table:—

|                         | Specific gravities. | Square roots of Specific gravities. | Diffusive volumes. |
|-------------------------|---------------------|-------------------------------------|--------------------|
| Hydrogen . . . . .      | 0.0688              | 0.2623                              | 457                |
| Ammonia . . . . .       | 0.5898              | 0.7681                              | 130                |
| Air . . . . .           | 1.0000              | 1.0000                              | 100                |
| Carbonic Acid . . . . . | 1.5239              | 1.2345                              | 81                 |
| Chlorine . . . . .      | 2.4700              | 1.5716                              | 64                 |

"By this table it will be seen that in the same time in which 100 volumes of atmospheric air escape from a vessel through a membranous or porous plug, 457 volumes of hydrogen pass in; and if the vessel was previously full of hydrogen, 457 volumes will escape from it during the entrance of 100 volumes of atmospheric air. If the vessel contains carbonic acid, the result would be the passage of 81 volumes in the same time; and so of the other gases.

"This law of the passage of gases through each other, is the same as that for the passage of air into a perfectly empty space. If the different gases be allowed to strain through a porous plug into a vessel, from which the air has been removed by the air pump, they will enter with different velocities, regulated by their specific gravities, precisely as in the former instance; and hence it is experimentally demonstrated that different gases are ultimately permeable to each other, precisely as the spaces they occupy would be if entirely empty: that the gases, in fact, form vacua to each other, but that so far as the law of mixture and the final effect are concerned, the mixture takes place more slowly is consequence of the mechanical obstruction."—KAHN'S *Elements of Chemistry*.

The importance of the action of the law of diffusion on gas stored in gasholders, and when retained in mains for any time, is considerable, as under these conditions, during a certain time, 457 volumes of hydrogen would issue from the main or holder, and be replaced by 100 volumes of atmospheric air, by these means reducing the illuminating power of the gas. Besides, according to the opinion of Dr. Frankland, to this diffusion of hydrogen, by which the carbon is deprived of its proper equivalent of that gas, is attributed the formation of naphthaline in the mains and services, which is no doubt the most reasonable theory hitherto offered for the presence of this troublesome compound.

SUPPLY OF GAS TO BALLOONS.

Formerly gas companies were frequently required to supply gas for aeronautical purposes, and at one period so numerous were the balloon ascensions at the Vauxhall Gardens, in London, that a gas works was there especially erected for supplying the gas. This description of amusement is sometimes now introduced, occasionally and more particularly in foreign towns. The capacity of the balloon being known, the time required to fill it, with a main of a given length and diameter, will be ascertained by reference to the table on the delivery of mains.

"The first ascent with a balloon filled with hydrogen was made on the 1st December, 1783, by Messrs. Charles and Robert, at Paris. In an hour-and-three-quarters they alighted on the meadow of Nesle, twenty-five miles from the metropolis, and finding that the silk globe still retained great buoyant power, M. Charles ventured alone upon a second ascent. The sun had set, and the shades of evening were gradually condensing into the darkness of night, but his courage was rewarded by a most novel and sublime spectacle. He shot upwards with such celerity as to have attained the height of two miles in about ten minutes, when the sun rose again to him in full orb, and from his lofty station in the heavens he contemplated the fading luminary, and watched its parting beams till it once more sunk below the horizon.

"The vapours rising from the earth collected in clouds, and veiled it from his sight, while the pale rays of the moon scattered gleams of various hues over their fantastic and changing forms. The region in which the aeronaut now hovered was extremely cold; the balloon appeared fully distended, and upon opening the valve the gas rushed out like a misty vapour into the external air. Prudence forbade this bold voyager to remain longer in such a situation; slowly, therefore, descending, he alighted in safety near the forest of Tour du Lay. The barometer, at the greatest elevation, fell to 20.05 inches, and the temperature sunk to 21° Fahrenheit; he therefore appears to have ascended to about 9,700 feet above the level of the sea."—BRANDE'S *Chemistry*.

DETERIORATION OF COAL GAS WHEN KEPT IN CONTACT WITH WATER.

A certain quantity of water cannot deteriorate coal gas to an unlimited degree, but only a certain amount of it, according to the co-efficients of absorption of water for the constituents of coal gas. These co-efficients vary with the temperature and pressure.

One volume of water absorbs of—

|                                      | At 32° Fahr. | At 59° Fahr. | At 68° Fahr. |
|--------------------------------------|--------------|--------------|--------------|
| Hydrogen . . . . .                   | 0.01930      | 0.01930      | 0.01930      |
| Carbonic oxide . . . . .             | 0.02287      | 0.02432      | 0.02312      |
| Light carburetted hydrogen . . . . . | 0.05449      | 0.03909      | 0.03499      |
| Olefiant gas . . . . .               | 0.2563       | 0.1615       | 0.1488       |

From this it appears that water at 59° Fahr. absorbs—

- 8.37 times more olefiant gas than hydrogen,
- 6.64 " " " carbonic oxide
- 4.13 " " " light carburetted hydrogen,

and that the deterioration of coal-gas by water only continues until the water is saturated with olefiant gas, further changes being due to changes in temperature and pressure. When the temperature of the water rises, the co-efficients of absorption diminish, and olefiant gas is set free; when it falls, a proportionate amount of olefiant gas is again absorbed. Pressure increases the absorptive power of water for gases.—DR. TORREY.

GAS AND WATER PIPES.

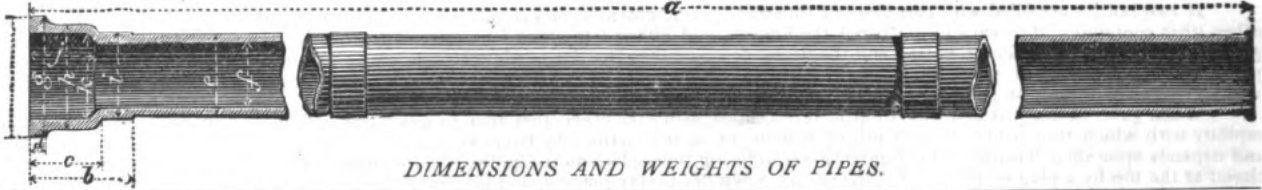

DIMENSIONS AND WEIGHTS OF PIPES.

| Inside diameter of Pipe in inches. | Length exclusive of Sockets. |     | Weight per Pipe. |      |      | Weight per Yard. |      |      | Weights subject to 5% variation. | Price per Ton. |    |    |
|------------------------------------|------------------------------|-----|------------------|------|------|------------------|------|------|----------------------------------|----------------|----|----|
|                                    | ft.                          | in. | cwt.             | qrs. | lbs. | cwt.             | qrs. | lbs. |                                  | £              | s. | d. |
| 1½                                 | 6                            | 0   |                  | 1    | 4    |                  |      | 16   |                                  |                |    |    |
| 2                                  | 6                            | 0   |                  | 1    | 14   |                  |      | 21   |                                  |                |    |    |
| 2½                                 | 6                            | 0   |                  | 2    | 0    |                  | 1    | 0    |                                  |                |    |    |
| 3                                  | 9                            | 0   |                  | 3    | 14   |                  | 1    | 5    |                                  |                |    |    |
| 4                                  | 9                            | 0   | 1                | 1    | 14   |                  | 1    | 24   |                                  |                |    |    |
| 5                                  | 9                            | 0   | 1                | 3    | 14   |                  | 2    | 14   |                                  |                |    |    |
| 6                                  | 9                            | 0   | 2                | 1    | 14   |                  | 3    | 5    |                                  |                |    |    |

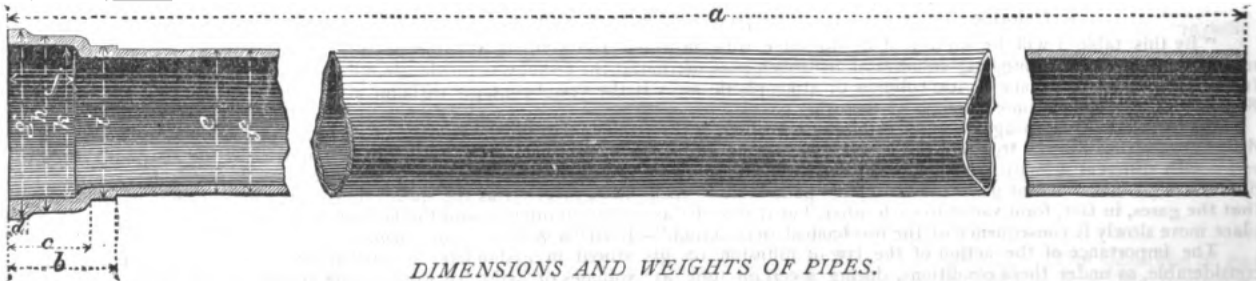

DIMENSIONS AND WEIGHTS OF PIPES.

| Inside diameter of Pipe in inches. | Length exclusive of Sockets. |     | Weight per Pipe. |      |      | Weight per Yard. |      |      | Weights subject to 5% variation. | Price per Ton. |    |    |
|------------------------------------|------------------------------|-----|------------------|------|------|------------------|------|------|----------------------------------|----------------|----|----|
|                                    | ft.                          | in. | cwt.             | qrs. | lbs. | cwt.             | qrs. | lbs. |                                  | £              | s. | d. |
| 8                                  | 9                            | 0   | 2                | 3    | 14   |                  | 3    | 24   |                                  |                |    |    |
| 9                                  | 9                            | 0   | 3                | 1    | 14   | 1                | 0    | 14   |                                  |                |    |    |
| 10                                 | 9                            | 0   | 4                | 0    | 7    | 1                | 1    | 2    |                                  |                |    |    |
| 12                                 | 9                            | 0   | 4                | 3    | 14   | 1                | 2    | 14   |                                  |                |    |    |
| 14                                 | 9                            | 0   | 5                | 2    | 14   | 1                | 3    | 14   |                                  |                |    |    |
| 15                                 | 9                            | 0   | 7                | 0    | 0    | 2                | 1    | 9    |                                  |                |    |    |
|                                    |                              |     | 8                | 2    | 0    | 2                | 3    | 9    |                                  |                |    |    |

| CONNECTIONS.                  | — |    |    | Extra per Ton if Coated. |    |    | — |    |    |
|-------------------------------|---|----|----|--------------------------|----|----|---|----|----|
|                               | £ | s. | d. | £                        | s. | d. | £ | s. | d. |
| 1½ to 2½ in. diameter per ton |   |    |    |                          |    |    |   |    |    |
| 3 " 6 " " "                   |   |    |    |                          |    |    |   |    |    |
| 7 " 15 " " "                  |   |    |    |                          |    |    |   |    |    |

N.B.—All Pipes of the above weights are tested by hydraulic pressure to 150 lbs. per square inch. Pipes made to any weight.

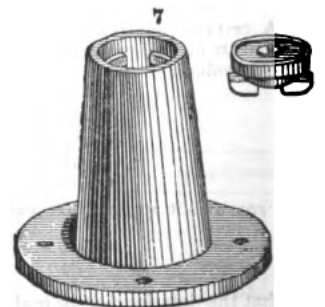
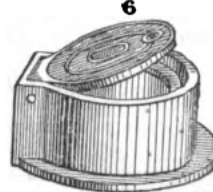
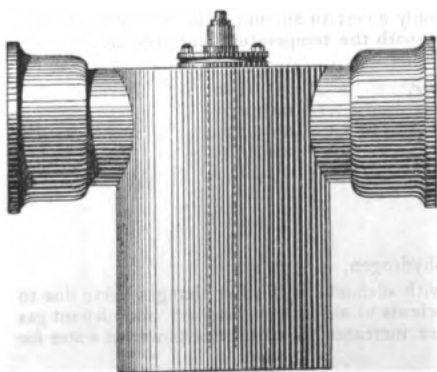

SYPHON BOXES

FILLED COMPLETE WITH COVERS, BOLTS, SUCTION PIPES, ETC.

SINKER PIPES, & SYPHONS FOR CROSSING CANALS, RIVERS, ETC. SYPHON TRAPS AND COVERS.

GEORGE BOWER, ST. NEOTS, HUNTINGDONSHIRE.

[N]

## SERVICES.

GEORGE BOWER,

*Gas and Water Engineer and Contractor, St. Neots, Hunts.*

The material generally used for services from the mains to the consumer's premises, or public lamps, is wrought-iron pipe, or, as generally called, wrought-iron tube, the quality of which is much more variable than is usually known. Inferior description of wrought-iron pipe, whether used either for services or fittings, causes considerable loss of time, arising from the irregularity of the screws, which have sometimes to be rescrewed in order to connect the pipes; it is often unsound through the welding being imperfectly effected; and the iron is of that nature that on attempting to bend a pipe when cold, or even when heated, it often breaks or splits. Therefore, for these and other reasons the best wrought-iron pipe should only be employed.

When used for services, in order to preserve it, the iron pipe may either be coated by the Bower process, or be heated and then well coated with tar, and in some soils which are very destructive the system employed by the Gas Light Company should be adopted. This consists in having a rudely made trough formed by two battens of 2½ or 3-inches wide and ½-inch thick nailed together, which is laid beneath and almost touches the service, when it is filled with hot pitch or a mixture of tar and sand, or other similar material, which entirely covers the pipe, so that it is thoroughly embedded in the pitch or tar, or other substance employed. By these means the service is rendered practically everlasting, and the cost is so trifling, when compared with its efficiency, that it is surprising these simple processes are not more universally applied.

The holes in the mains for services ought always to be drilled, and never cut with a gouge, as when drilled they are tapped with greater facility; there is not the escape which occurs with an imperfectly formed hole in the main; besides, the operation is effected more readily and with less loss of gas than with the gouge. An apparatus has been invented by which a main may be drilled and tapped when charged without any loss of gas or water. In certain localities this apparatus is indispensable.

A main of 2-inches diameter should never be tapped for a larger pipe than ¾-inch, otherwise it will be most materially weakened and will break with the slightest settlement or jar. For the same reason, a 3-inch main may be tapped for a 1-inch pipe, but not larger, and in the event of the services being required of greater dimensions this can be effected with diminishing sockets, for a slight reduction in the diameter of the pipe for a very short distance will not impede the gas through a service. A good plan, though but seldom adopted, is to have bosses cast upon the main, into which the services may be very securely tapped.

The same incline for the flow of condensed liquor observed in laying mains must also be observed in laying services, and in the event of a syphon being required, this is supplied by the bottle syphon, shown on p. 113, which is screwed to and forms part of the service. These are made of all sizes, to contain from one to three quarts, and attached to each is the suction pipe for withdrawing the liquid.

The service pipes to all public lamps are usually of ½ inch pipe, unless when of considerable length, when they are laid of ¾-inch pipe. Services to houses of the ordinary kind are of ¾-inch pipe, and smaller than this is rarely employed, except with consumers having one or two lights only, and where any increased consumption cannot be expected.

The following table gives the diameter of the pipes required for any number of lights, each burner consuming 5 feet per hour, or an equivalent quantity of gas distributed, as may be considered necessary, with the extreme length for which they are suitable, and the quantity delivered per hour at a pressure of five-tenths of an inch of water. But in practice, in consequence of the possible obstruction by naphthaline, the lengths of the respective services should never exceed more than half of those indicated for the stated delivery:—

| From | 1 to  | 3 lights, | Diameter<br>of Pipe. | inch length of service in | Yards. | Quantity delivered<br>per hour. |
|------|-------|-----------|----------------------|---------------------------|--------|---------------------------------|
|      |       |           | ½                    | 100                       | ...    | 26 cubic feet.                  |
| "    | 3 "   | 5 "       | ¾                    | "                         | 150    | 60 "                            |
| "    | 5 "   | 10 "      | 1                    | "                         | 100    | 74 "                            |
| "    | 10 "  | 20 "      | 1 ¼                  | "                         | 100    | 151 "                           |
| "    | 20 "  | 40 "      | 1 ½                  | "                         | 100    | 264 "                           |
| "    | 40 "  | 70 "      | 1 ¾                  | "                         | 25     | 528 "                           |
| "    | 70 "  | 100 "     | 2                    | "                         | 25     | 760 "                           |
| "    | 100 " | 150 "     | 2                    | "                         | 100    | 1033 "                          |

Particulars are given on next page of the various tools necessary for service laying,—as gas tongs, screw taps, stocks and dies, together with main cocks and keys, bottle syphon, etc.

Furnished with wrought-iron pipe are the various pieces necessary for the completion of iron fittings or services, such as short pieces, bends, springs, elbows, T pieces, crosses, plugs, sockets, nipples, back nuts and main cocks, as represented in the following drawings, which are accompanied with the list of all the corresponding prices:—

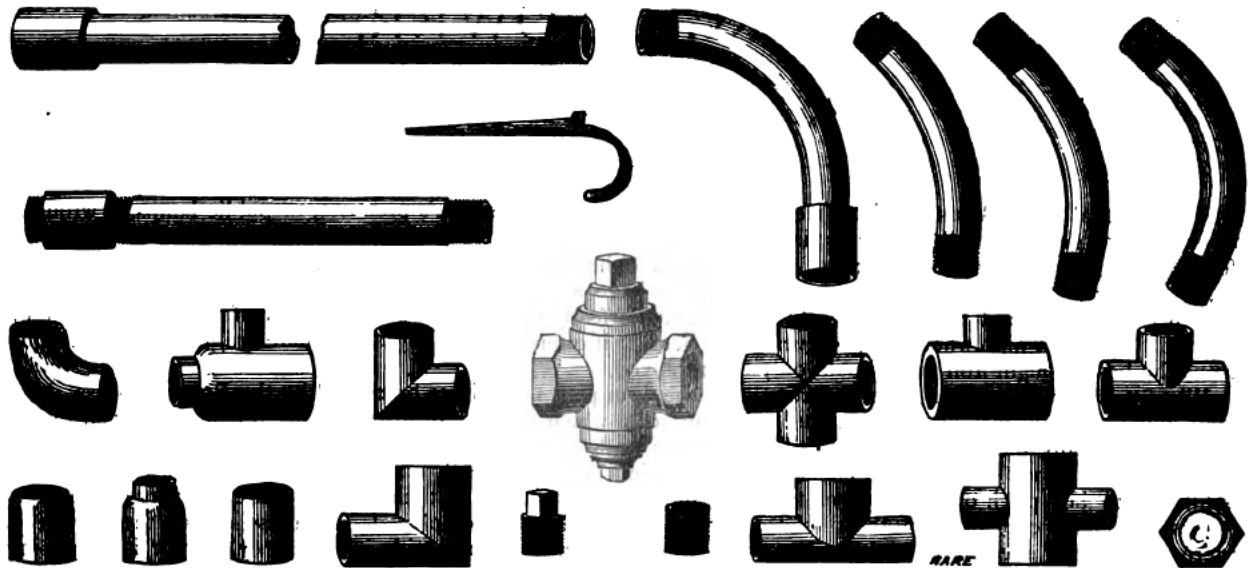

WROUGHT IRON TUBE AND FITTINGS.

PRICES.

| Inside Diameter, in Inches.         | 1/8 |       | 1/4 |       | 3/8 |       | 1/2 |       | 3/4 |    | 1  |    | 1 1/4 |    | 1 1/2 |    | 1 3/4 |    | 2  |    | 2 1/2 |    | 2 3/4 |    | 3  |    |    |   |   |
|-------------------------------------|-----|-------|-----|-------|-----|-------|-----|-------|-----|----|----|----|-------|----|-------|----|-------|----|----|----|-------|----|-------|----|----|----|----|---|---|
|                                     | s.  | d.    | s.  | d.    | s.  | d.    | s.  | d.    | s.  | d. | s. | d. | s.    | d. | s.    | d. | s.    | d. | s. | d. | s.    | d. | s.    | d. | s. | d. |    |   |   |
| Tubes, from 2 to 14 ft. per foot    | 0   | 2 1/2 | 0   | 3     | 0   | 3 1/2 | 0   | 4 1/2 | 0   | 6  | 0  | 8  | 0     | 11 | 1     | 2  | 1     | 6  | 1  | 9  | 2     | 6  | 3     | 3  | 4  | 0  | 4  | 6 |   |
| „ 12 to 23 1/2 in. each             | 0   | 4     | 0   | 5     | 0   | 7     | 0   | 9     | 1   | 0  | 1  | 4  | 1     | 8  | 2     | 0  | 2     | 6  | 3  | 0  | 4     | 6  | 6     | 3  | 7  | 6  | 9  | 0 |   |
| „ 3 to 11 1/2 in. „                 | 0   | 2     | 0   | 3     | 0   | 4     | 0   | 6     | 0   | 8  | 0  | 11 | 1     | 1  | 1     | 4  | 2     | 0  | 2  | 3  | 4     | 0  | 4     | 9  | 6  | 0  | 7  | 0 |   |
| Connecting Tube, 12 to 23 1/2 in. „ | 0   | 5     | 0   | 7     | 0   | 9     | 0   | 11    | 1   | 2  | 1  | 6  | 2     | 0  | 2     | 6  | 3     | 3  | 4  | 0  | 5     | 6  | 7     | 0  | 8  | 6  | 10 | 0 | 0 |
| „ 3 to 11 1/2 in. „                 | 0   | 4     | 0   | 5     | 0   | 6     | 0   | 8     | 0   | 10 | 1  | 0  | 1     | 3  | 2     | 0  | 2     | 6  | 3  | 0  | 4     | 6  | 5     | 6  | 6  | 6  | 7  | 6 | 6 |
| Tubular Bends and Lamp Bends „      | 0   | 3 1/2 | 0   | 6 1/2 | 0   | 7     | 0   | 8     | 0   | 11 | 1  | 3  | 1     | 9  | 2     | 3  | 3     | 3  | 4  | 3  | 6     | 6  | 10    | 0  | 12 | 0  | 16 | 0 | 0 |
| Springs, various elevations „       | 0   | 4     | 0   | 5     | 0   | 6     | 0   | 7     | 0   | 9  | 0  | 11 | 1     | 4  | 1     | 8  | 2     | 6  | 3  | 3  | 5     | 6  | 7     | 6  | 10 | 0  | 12 | 0 | 0 |

FITTINGS.

|                                       | s. | d.    | s. | d.    | s. | d. | s. | d. | s. | d.    | s. | d. | s. | d. | s. | d. | s. | d. | s. | d. | s. | d. | s. | d. | s.  | d. | s. | d. |   |   |
|---------------------------------------|----|-------|----|-------|----|----|----|----|----|-------|----|----|----|----|----|----|----|----|----|----|----|----|----|----|-----|----|----|----|---|---|
| Socket or Pipe Unions, wt. iron, each | .. | 2     | 0  | 2     | 6  | 3  | 0  | 4  | 0  | 5     | 6  | 6  | 9  | 8  | 0  | 9  | 0  | 10 | 0  | 12 | 0  | 14 | 0  | 16 | 0   | 18 | 0  | 18 | 0 |   |
| Elbows, Equal or Diminished „         | 0  | 6     | 0  | 6 1/2 | 0  | 7  | 0  | 8  | 0  | 10    | 1  | 2  | 1  | 9  | 2  | 3  | 3  | 0  | 3  | 6  | 5  | 6  | 8  | 6  | 11  | 0  | 14 | 0  | 0 |   |
| Tees „                                | 0  | 6     | 0  | 6 1/2 | 0  | 7  | 0  | 9  | 1  | 0     | 1  | 3  | 1  | 9  | 2  | 6  | 3  | 0  | 3  | 9  | 6  | 0  | 9  | 6  | 12  | 6  | 16 | 6  | 6 |   |
| Crosses „                             | 0  | 10    | 1  | 0     | 1  | 0  | 1  | 5  | 1  | 9     | 2  | 3  | 3  | 0  | 3  | 6  | 4  | 6  | 5  | 3  | 10 | 6  | 16 | 0  | 21  | 0  | 30 | 0  | 0 |   |
| Sockets, Plain „                      | 0  | 1 1/2 | 0  | 1 1/2 | 0  | 2  | 0  | 3  | 0  | 3 1/2 | 0  | 4  | 0  | 6  | 0  | 7  | 0  | 9  | 1  | 0  | 1  | 6  | 2  | 6  | 3   | 0  | 3  | 0  | 6 | 6 |
| „ Diminished „                        | .. | 0     | 3  | 0     | 4  | 0  | 5  | 0  | 6  | 0     | 7  | 0  | 9  | 0  | 11 | 1  | 1  | 1  | 1  | 3  | 2  | 0  | 3  | 0  | 4   | 0  | 5  | 0  | 3 | 6 |
| Flanges „                             | 0  | 8     | 0  | 9     | 0  | 10 | 1  | 0  | 1  | 2     | 1  | 4  | 1  | 6  | 1  | 9  | 2  | 0  | 2  | 6  | 3  | 9  | 5  | 0  | 6   | 9  | 8  | 6  | 6 | 6 |
| Caps and Plugs „                      | 0  | 2     | 0  | 3     | 0  | 3  | 0  | 4  | 0  | 5     | 0  | 6  | 0  | 8  | 0  | 10 | 1  | 0  | 1  | 3  | 2  | 0  | 2  | 6  | 3   | 6  | 4  | 9  | 6 | 6 |
| Backnuts and Nipples „                | 0  | 1     | 0  | 2     | 0  | 2  | 0  | 3  | 0  | 3 1/2 | 0  | 4  | 0  | 6  | 0  | 8  | 0  | 10 | 1  | 0  | 1  | 9  | 2  | 3  | 3   | 0  | 3  | 0  | 6 | 6 |
| Union Bends, or Elbows „              | .. | 2     | 6  | 3     | 0  | 3  | 9  | 5  | 0  | 6     | 3  | 8  | 6  | 10 | 0  | 11 | 6  | 13 | 6  | 16 | 0  | 19 | 0  | 22 | 0   | 25 | 0  | 0  | 0 |   |
| Elbows, Round Backed, wt. iron „      | 0  | 7     | 0  | 7     | 0  | 8  | 0  | 9  | 1  | 0     | 1  | 4  | 1  | 11 | 2  | 6  | 3  | 4  | 3  | 10 | 6  | 10 | 0  | 13 | 0   | 16 | 0  | 0  | 0 |   |
| Iron Main Cocks „                     | 2  | 3     | 2  | 3     | 2  | 9  | 3  | 6  | 4  | 6     | 6  | 6  | 8  | 6  | 11 | 0  | 14 | 0  | 18 | 0  | 27 | 0  | 36 | 0  | 44  | 0  | 50 | 0  | 0 |   |
| „ with brass Plugs „                  | .. | ..    | 4  | 6     | 5  | 6  | 7  | 6  | 10 | 6     | 15 | 0  | 19 | 6  | 25 | 0  | 32 | 0  | 47 | 0  | 60 | 0  | 90 | 0  | 110 | 0  | 0  | 0  | 0 |   |



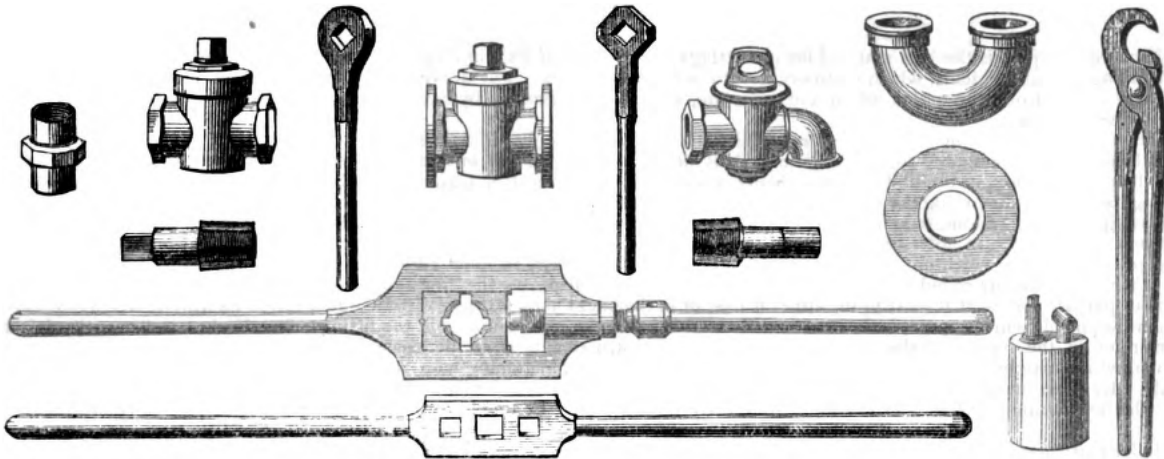

PRICES OF SUNDRY FITTINGS FOR IRON SERVICES.

| Internal diameter of Tube.                | in. $\frac{1}{8}$ |     | in. $\frac{1}{4}$ |     | in. $\frac{3}{8}$ |     | in. $\frac{1}{2}$ |     | in. $\frac{3}{4}$ |     | in. 1 |     | in. $1\frac{1}{4}$ |     | in. $1\frac{1}{2}$ |    | in. $1\frac{3}{4}$ |     | in. 2 |     | in. $2\frac{1}{4}$ |     | in. $2\frac{1}{2}$ |     | in. $2\frac{3}{4}$ |     | in. 3 |     |   |
|-------------------------------------------|-------------------|-----|-------------------|-----|-------------------|-----|-------------------|-----|-------------------|-----|-------|-----|--------------------|-----|--------------------|----|--------------------|-----|-------|-----|--------------------|-----|--------------------|-----|--------------------|-----|-------|-----|---|
|                                           | s.                | d.  | s.                | d.  | s.                | d.  | s.                | d.  | s.                | d.  | s.    | d.  | s.                 | d.  | s.                 | d. | s.                 | d.  | s.    | d.  | s.                 | d.  | s.                 | d.  | s.                 | d.  | s.    | d.  |   |
| Spanners for cocks . . . . . each         | ...               | ... | 0                 | 6   | 0                 | 7   | 0                 | 8   | 0                 | 9   | 0     | 11  | 1                  | 2   | 1                  | 4  | 1                  | 6   | 1     | 9   | 2                  | 0   | 2                  | 3   | 2                  | 6   |       |     |   |
| Pipe tongs or nippers . . . . . per pair  | 1                 | 8   | 1                 | 8   | 1                 | 8   | 2                 | 0   | 2                 | 3   | 2     | 9   | 3                  | 2   | 4                  | 0  | 4                  | 4   | 8     | 6   | 0                  | 7   | 6                  | 8   | 3                  | 9   | 0     |     |   |
| Bottle syphon for services, 1 quart, each | ...               | ... | ...               | 4   | 6                 | 4   | 6                 | 4   | 9                 | 5   | 0     | 5   | 3                  | 5   | 6                  | 5  | 9                  | 6   | 0     | ... | ...                | ... | ...                | ... | ...                | ... | ...   | ... |   |
| Ditto " " 2 " "                           | ...               | ... | ...               | 6   | 0                 | 6   | 6                 | 7   | 0                 | 7   | 3     | 7   | 6                  | 7   | 9                  | 8  | 0                  | ... | ...   | ... | ...                | ... | ...                | ... | ...                | ... | ...   | ... |   |
| Ditto " " 3 " "                           | ...               | ... | ...               | ... | ...               | ... | ...               | ... | ...               | ... | ...   | ... | ...                | ... | 9                  | 0  | 10                 | 0   | 11    | 3   | 12                 | 9   | 14                 | 6   |                    |     |       |     |   |
| Flanges . . . . .                         | 0                 | 5   | 0                 | 5   | 0                 | 5   | 0                 | 6   | 0                 | 7   | 0     | 8   | 0                  | 9   | 0                  | 10 | $\frac{1}{2}$      | 1   | 0     | 1   | 0                  | 1   | 6                  | 2   | 0                  | 2   | 9     | 2   | 9 |

PRICES OF SCREWING STOCKS, TAPS, AND DIES, &c.

|                                                                                                                             | No. 1. Set. |                    |                    | No. 2. Set. |                    |                    | No. 3. Set. |                   |                   | No. 4. Set.       |                   |                   |
|-----------------------------------------------------------------------------------------------------------------------------|-------------|--------------------|--------------------|-------------|--------------------|--------------------|-------------|-------------------|-------------------|-------------------|-------------------|-------------------|
|                                                                                                                             | in. 3       | in. $2\frac{1}{2}$ | in. $2\frac{1}{4}$ | in. 2       | in. $1\frac{1}{2}$ | in. $1\frac{1}{4}$ | in. 1       | in. $\frac{3}{4}$ | in. $\frac{1}{2}$ | in. $\frac{3}{8}$ | in. $\frac{1}{4}$ | in. $\frac{1}{8}$ |
| Stocks, with 3 pairs of taps and dies, }<br>per set . . . . .                                                               |             |                    |                    |             |                    |                    |             |                   |                   |                   |                   |                   |
| Dies . . . . . per pair                                                                                                     |             |                    |                    |             |                    |                    |             |                   |                   |                   |                   |                   |
| Taps . . . . . per pair                                                                                                     |             |                    |                    |             |                    |                    |             |                   |                   |                   |                   |                   |
| Tap wrenches . . . . . each                                                                                                 |             |                    |                    |             |                    |                    |             |                   |                   |                   |                   |                   |
| Rymers, hexagon or octagon, & stocks, }<br>taps and dies for $\frac{3}{8}$ , $\frac{1}{2}$ , and $\frac{5}{8}$ brass tube } |             |                    |                    |             |                    |                    |             |                   |                   |                   |                   |                   |

LEAD SERVICE PIPE AND FITTINGS.  
 APPARATUS FOR TESTING MAIN PIPES.  
 PORTABLE VICE AND BENCHES.  
 FIRE BASKETS.  
 LEAD PANS AND LADLES.

For further description of Tools, See SECTION S.

GEORGE BOWER, ST. NEOTS, HUNTINGDONSHIRE.

## MANAGEMENT OF GAS.

Wrought-iron pipe is the best material for gas fittings, on account of its durability, its strength, and retaining its straight form, and thus avoiding dips and indents, which often occur with soft metal pipes. The decay of wrought-iron pipes only takes place on the exterior, and results from the action of air and moisture, which can be avoided by having them galvanised or coated with magnetic oxide by the Bower process.

The pipes comprising the fittings of an establishment should always be of ample capacity, to admit of a good supply throughout when all the burners are lighted together; indeed, it is always the best to be on the safe side by having them too large rather than too small, the extra expense, in the first instance, being a mere trifle in the cost of materials, whilst it enables the consumer to alter, or add to his lights, without disturbing the original arrangement of his fittings.

Throughout their various ramifications, the pipes should have a slight inclination towards the point where the main cock is fixed, and thence to the meter, in order to allow the water which is occasionally deposited in them, to drain off without interrupting the passage of the gas. In fittings which are not thus arranged, the water accumulates in some curvature of the pipes, and occasions an oscillation, or, as it is very commonly called, jumping of the lights. When this happens, the first thing to be ascertained is, whether the cause be general or partial, that is, if it exist in the street mains, or in the consumer's fittings. If the lights in the immediate neighbourhood, and which are supplied from the main, burn steadily, it is a proof that the obstruction is in the fittings; but if they oscillate, the defect is in the main, or in the service of the house. Supposing the obstruction to be in the consumer's fittings, it is desirable to determine its situation, which may be done by turning off one light after another, beginning with that which oscillates the most, until the rest burn steadily. By these means the pipe which causes the oscillation will be readily discovered. If all the lights on the premises are affected alike, whether burning separately or in conjunction, then the cause must be sought for in the principal service-pipe in connection with the main.

Under particular circumstances, it is impossible to fix the pipes so that they may all incline towards the street main. In that case, the lowest point must be fitted with what is usually but improperly termed a syphon, which consists of a piece of tube with a stop-cock near its extremity. The condensable products flow to the syphon, and may be drawn off periodically.

Imperfect fittings are an intolerable nuisance. Where leaks exist, they should be immediately searched for and stopped. An escape of gas may exist for years without endangering either health or property; but it is as equally unnecessary as it is unpleasant. A small crack, or other defect in a pipe, will permit just enough gas to pass to diffuse its characteristic odour. For stopping such escapes temporarily, nothing is better than coarse tape or strips of calico, smeared with white lead, and bound tightly over the defective part, but they should be rejoined permanently without delay.

The utility of gas in bedrooms in the night-time is one of its recommendations, indeed, in the event of sudden illness or alarm a house can be lighted throughout in the course of a few seconds, and for this reason it is seldom shut off from private dwellings. In other buildings, such as manufactories, warehouses, and other large premises, the gas should be shut off at the main cock every night, and the few lights that it may be necessary to burn during the whole night should be supplied by a separate meter and fittings, or by a small by-pass.

In large establishments, it is a good plan to entrust the supervision of the fittings to one of the domestics, or where the consumer manufactures his own gas, to his gas-maker or manager, with instructions to make his inspections at regular intervals, say once a week.

The meter should be placed near the main-cock, in a dry situation, well lighted and ventilated, and easy of access; where it will not be affected by sudden or extreme changes of temperature; also in as direct a line as possible between the street-main and the burners, and below the level of all the fittings. If the meter be too much exposed, it will in winter be liable to be put out of action by the water in it freezing.

When it is absolutely necessary that the meter be placed outside the house, or in an exposed situation, it should be protected from extremes of heat and cold by surrounding it with old woollen cloths, or with dry sawdust to the thickness of two or three inches, for which latter purpose a wooden case will be required.

Gas by itself is not explosive, but is so rendered by being intermixed with atmospheric air. One volume of gas, with eight volumes of air, is generally considered the most explosive compound, although all mixtures, ranging from three to sixteen parts of air to one of gas, are more or less dangerous.

Gas being lighter than air, on escaping ascends to the ceiling, and in a short time, according to the extent of the escape and the capacity of the locality, the atmosphere near the ceiling becomes highly explosive, whilst the odour of gas may be hardly perceptible in the lower parts. For this reason, whenever an escape of gas occurs ordinary caution must be observed to avoid accidents, but on no account must a flame be used to detect it. Should the odour of escaping gas become perceptible whilst it is lighted, then on investigation one of the taps may be found turned on, or, what is still more probable, in the event of one or more hydraulic gasaliers being in the apartment, one of them may be deficient of water, which should be at once supplied, but no light should be used for the purpose. Or should the escape happen during the day-time it will be probably due to a fracture, which should be detected by the odour, and on no account must a lighted candle or match be used. The upper part of the windows and the doors should be opened, to allow the gas to issue, the main tap should be turned off, when on carefully inspecting the fittings the defect will be discovered; and this frequently occurs in some obscure inaccessible corner, where materials are placed by which the pipes are broken. The defect being repaired, the gas is again turned on, when by smelling it can be ascertained if the evil is entirely remedied.

In order to prevent the evaporation of water in hydraulic joints of gasaliers, in the act of supplying the water two tea spoonful of olive oil should be added, which will float on the top.

To secure a house, manufactory, or other building being properly lighted, when common gas is used, a pressure of not less than six-tenths of an inch, and with cannel gas, a pressure of eight-tenths, is requisite in the mains of the company supplying. Of this about two-tenths will be absorbed by the meter when supplying the full quantity for which it is intended, and all the pipes in the building should be sufficiently large to allow the full quantity of gas to pass at a pressure of four-tenths of an inch, this being ample for any description of burners with common gas. Cannel gas requires more pressure than the other, on account of the flames of batwing and fishtail burners issuing in thinner streams, and demanding a greater supply of oxygen for combustion.

When the gas of any premises is suddenly extinguished, and the meter supplying is a wet one, it generally arises from an insufficiency, or it may be due to an excess of water in the meter; the remedy for both these contingencies is referred to elsewhere. One important consideration in the interest of gas companies is, that the meters should be properly charged with water, which operation is performed by some companies twice a quarter. If a wet meter be placed in a locality where it is liable to receive a blow or shock, by either of these mishaps the lights will be extinguished. The lights in an establishment may also be extinguished by the water within the meter freezing, in which case a quantity of boiling water may be poured into it; after allowing about ten minutes to elapse, the surplus water can be withdrawn. When a dry meter does not allow the gas to pass, it should be at once replaced by another, as the defect is in the instrument itself.

On the first establishment of gas lighting copper pipes were very generally used for the fittings, when by the action of the ammonia on the copper a highly explosive compound was formed. Several accidents occurred to workmen when in the act of removing the obstruction from the pipe, as the mere friction of passing a rod into it caused ignition and an explosion. Copper pipes are now entirely out of use.

[O]

STREET LAMPS, COLUMNS, AND BRACKETS,

MANUFACTURED AND SUPPLIED BY

GEORGE BOWER,

*Gas and Water Engineer and Contractor, St. Neots, Hunts.*

THE SHADOWLESS LAMP, No. 40.

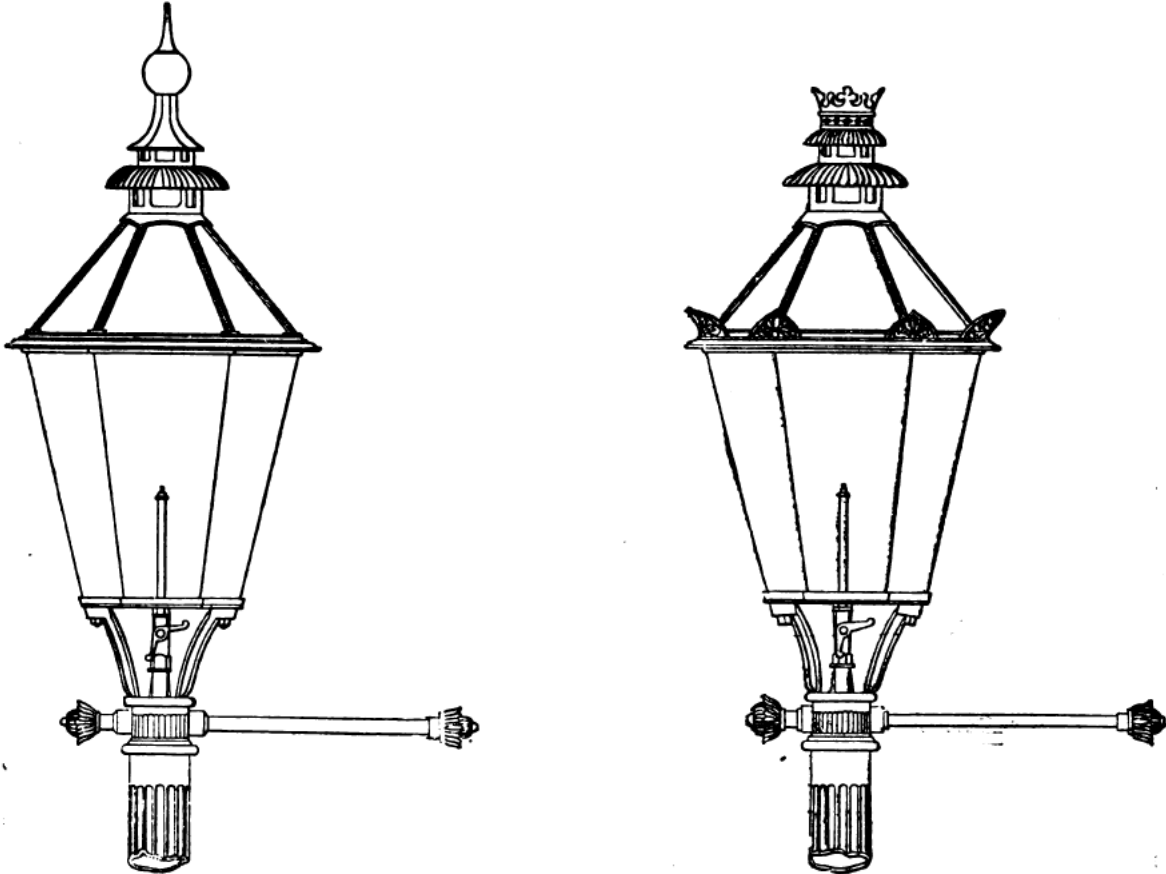

These Lanterns are designed for the purpose of remedying some of the defects and supplying deficiencies in the usual apparatus for street lighting, as the following description explains :—

The framework is of cast iron, and the top and bottom frames (connected by wrought-iron rods) have grooves formed in them in such a manner that each succeeding pane of glass, on being slid into its place, locks the preceding one, the last one being secured by a little putty. The top may be fitted in with white enamelled plates, instead of glass, for the double purpose of protection from hail storms and for deflecting the light.

All the parts are made to gauge, and any damaged portion of a lamp can be replaced by a duplicate. A lantern can be taken to pieces and put together in a few minutes, and broken glass can be replaced without removing the lantern from the column.

The bottom frame is so constructed that the gas is turned on and lighted by means of a torch, and is made open, or can be partly glazed and fitted with a gauze wire door for the admission of air.

The top frame of some of the lanterns is made to lift off: in others it is hinged, in order that the top may be lifted off or thrown back for the purpose of cleaning the interior.

The packing space is reduced to a minimum, and a large saving in freight is effected when required for export. The gross weight of 50 lanterns, complete with lever cocks, carriers, ladder bars, and 50 sets of glass, being 24 cwt.; while the measurement space required for the same does not exceed 30 cwt. The same number of tin lanterns would require three times that space.

GEORGE BOWER, ST. NEOTS, HUNTINGDONSHIRE.

CAST IRON LAMP COLUMNS.

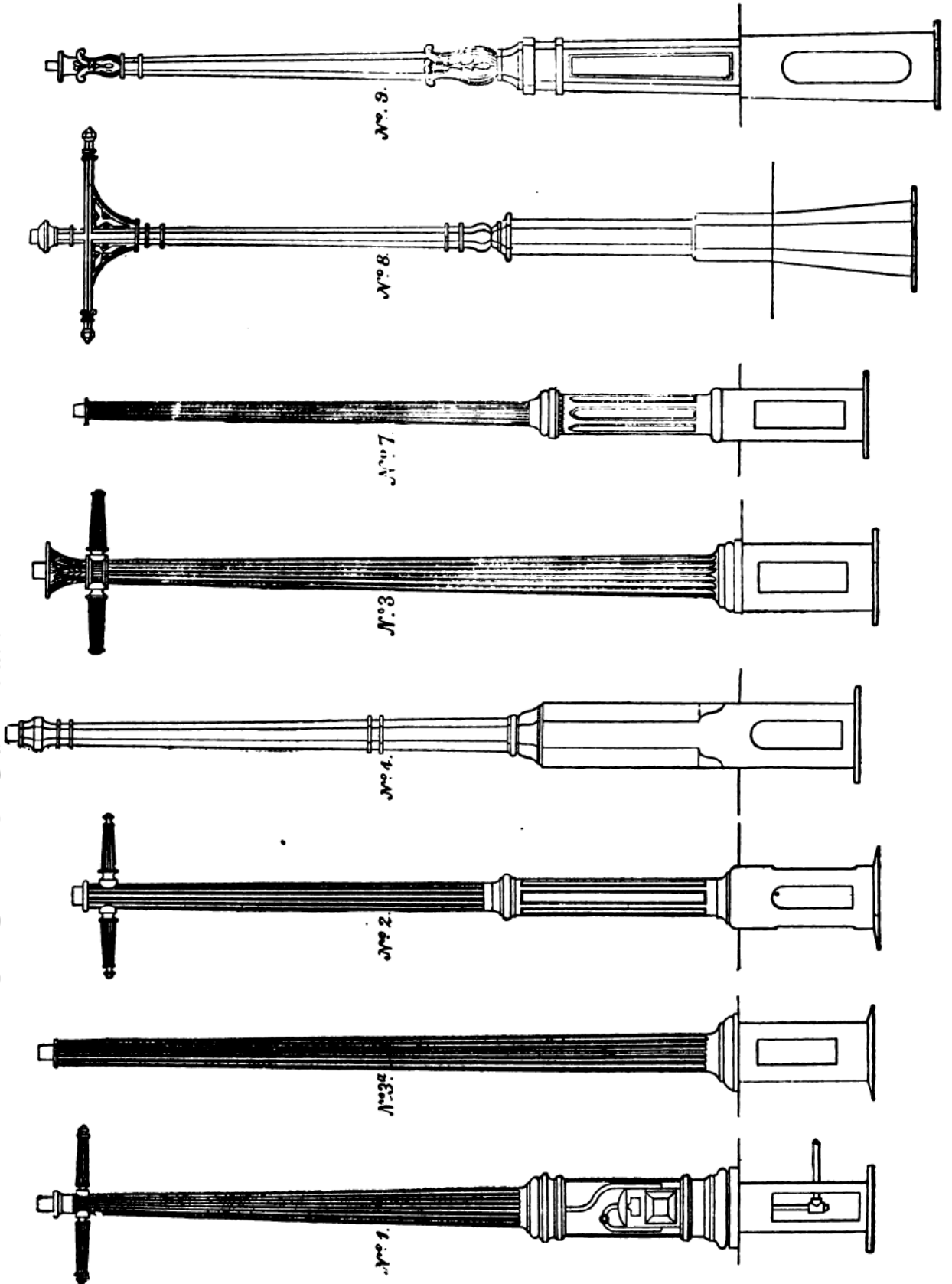



No. 3

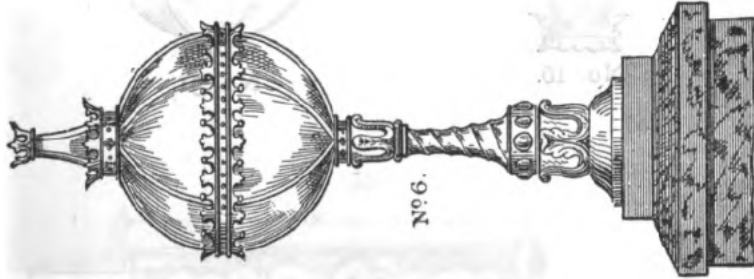

No. 6.



LAMP CARRIERS FOR COLUMNS



No. 10.

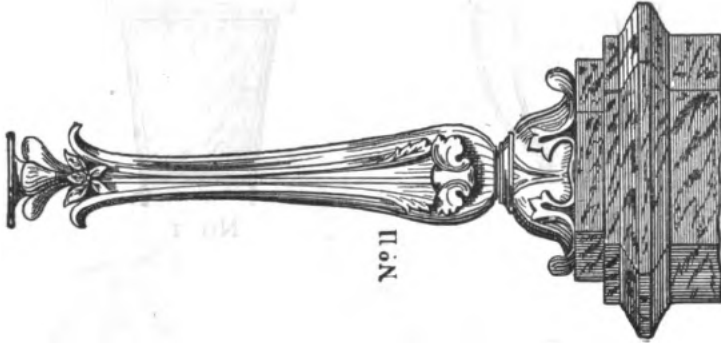

No. 11

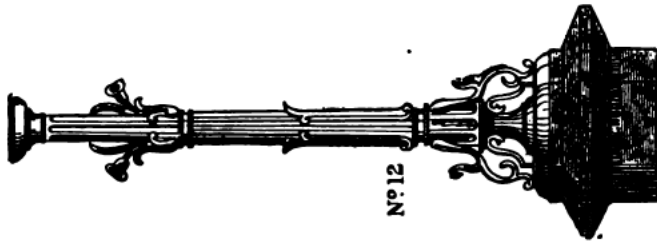

No. 12

DESCRIPTIONS OF LAMP COLUMNS.

- |        |     |                                                                                      |
|--------|-----|--------------------------------------------------------------------------------------|
| Number | 1.  | Strong column made to contain a meter in the base, with door, lock and key complete. |
| "      | 2.  | Strong fluted column with cast-iron arms screwed in, convenient for packing.         |
| "      | 3.  | Ditto.                                                                               |
| "      | 3A. | Strong fluted column, with top suited for lamp carrier, with ladder bar.             |
| "      | 4.  | Strong hexagon column, with wrought-iron ladder bar to screw in.                     |
| "      | 5.  | Light mediæval column, suitable for church approaches, etc.                          |
| "      | 6.  | Short column for fixing on piers of entrance gates, etc.                             |
| "      | 7.  | Light column, with top suited for lamp carrier, with ladder bar.                     |
| "      | 8.  | Ornamental column, suitable for church approaches.                                   |
| "      | 9.  | Strong ornamental column.                                                            |
| "      | 10. | Pillar column.                                                                       |
| "      | 11. | Ditto.                                                                               |
| "      | 12. | Ditto.                                                                               |

N.B.—The columns shown without ladder bars have them fitted into the lantern carrier. See illustration of the Shadowless Lamp.

## LAMPS OR LANTERNS.



No. 14.



No. 33.



No. 15.



No. 17.

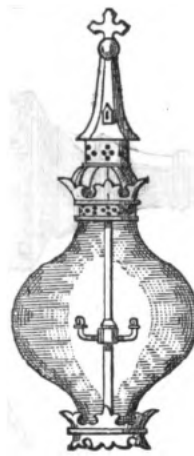

No. 16.



No. 31.

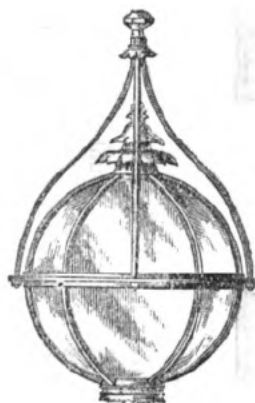

No. 35.



No. 34.

# CAST IRON BRACKETS,

FITTED WITH SUITABLE BACKS, THAT THEY MAY BE FIXED ON THE  
FACE OR CORNER OF WALLS AS DESIRED.

CAST-IRON BACKS, FOR BRACKETS.

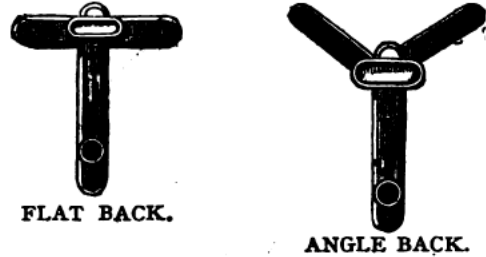

No. 31.

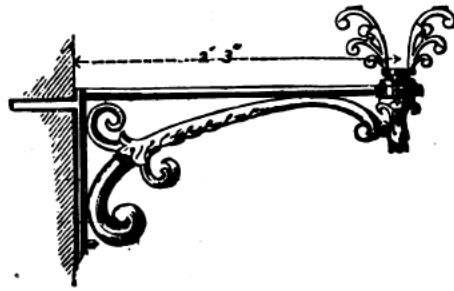
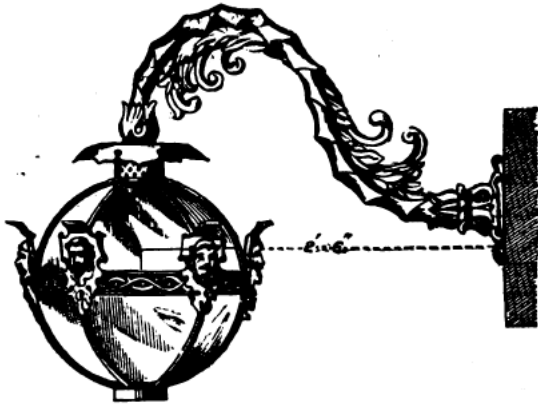

No. 32.

THE GLOBE LANTERNS REPRESENTED ARE  
VERY GENERALLY ADOPTED AT RAILWAY STATIONS, ON BRIDGES AND PROMENADES,  
AND ARE TO BE RECOMMENDED FOR THEIR ELEGANCE.

No. 34.

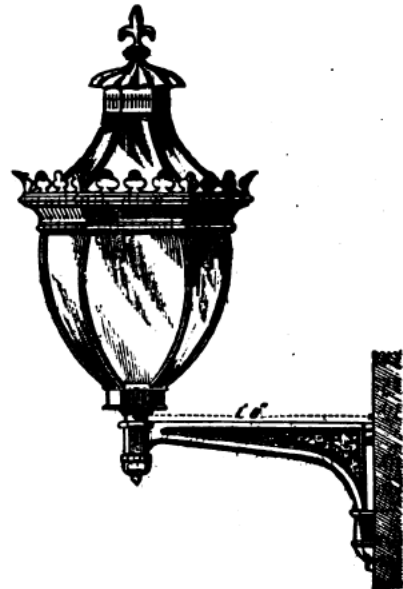
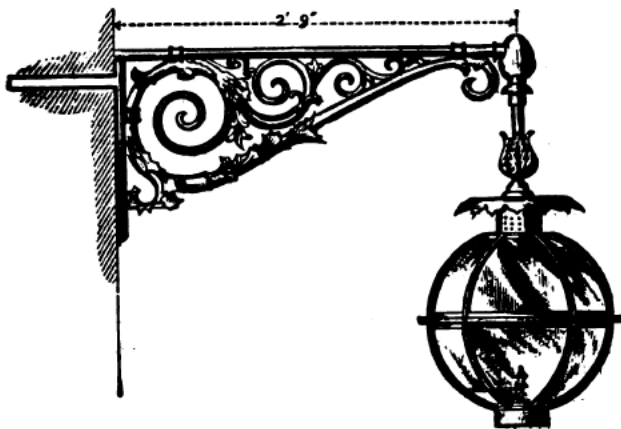

No. 33.

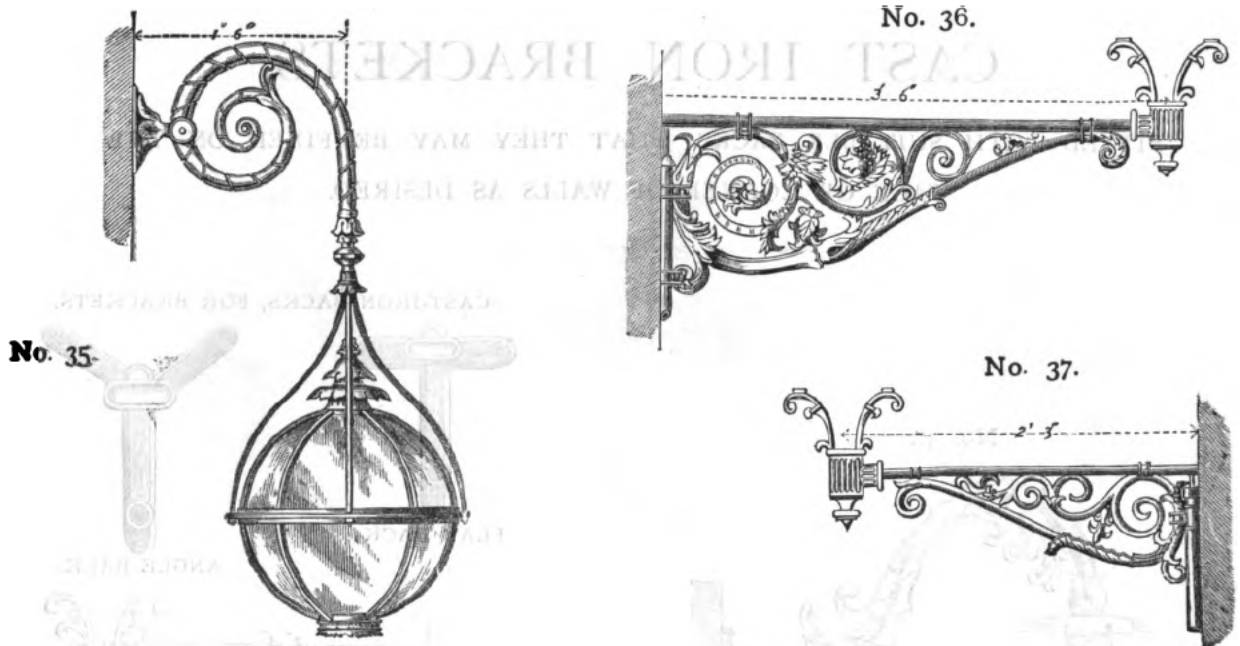

PRICES OF BRACKETS ONLY.

|         | £ | s. | d. |
|---------|---|----|----|
| No. 31. |   |    |    |
| „ 32.   |   |    |    |
| „ 33.   |   |    |    |
| „ 34.   |   |    |    |
| „ 35.   |   |    |    |
| „ 36.   |   |    |    |
| „ 37.   |   |    |    |

LANTERNS PAINTED AND GLAZED.

| Size of Lanterns, in Inches. |                                                                                                  | 13 | 14 | 16 | 18 |
|------------------------------|--------------------------------------------------------------------------------------------------|----|----|----|----|
| No. 14.                      | Hexagon Lantern, with tin frame, glass side door, and opening in bottom for lighting with torch  |    |    |    |    |
| „ 14.                        | Ditto, copper frame, glass, etc.                                                                 |    |    |    |    |
| „ 15.                        | Square Lantern, with tin frame, glass side door, and opening in bottom for lighting with torch   |    |    |    |    |
| „ 15.                        | Ditto, with copper frame                                                                         |    |    |    |    |
| „ 33.                        | Hexagon Lantern, with copper frame, glass, and side door                                         |    |    |    |    |
| „ 17.                        | Globe Lantern, with iron frame, glass, and door                                                  |    |    |    |    |
| „ 31.                        | Ditto,                                                                                           |    |    |    |    |
| „ 34.                        | Ditto,                                                                                           |    |    |    |    |
| „ 35.                        | Ditto,                                                                                           |    |    |    |    |
| „ 39.                        | Square Lanterns, with iron frame, glass, and opening at bottom for lighting with torch as No. 15 |    |    |    |    |
| „ 40.                        | Hexagon Lantern, with iron frame and glass (see page 115)                                        |    |    |    |    |
| „ 16.                        | Glass Lantern, with ornamental cap and base                                                      |    |    |    |    |

NOTE—Nos. 39 and 40 are constructed so as to offer as little obstruction to the light as possible; the top and bottom panes being connected together by two small iron rods only, the vertical edges of the squares of glass meeting at the angles.

CAST OR WROUGHT IRON BRACKETS OF OTHER DESIGNS AS MAY BE REQUIRED.

GEORGE BOWER, ST. NEOTS, HUNTINGDONSHIRE.



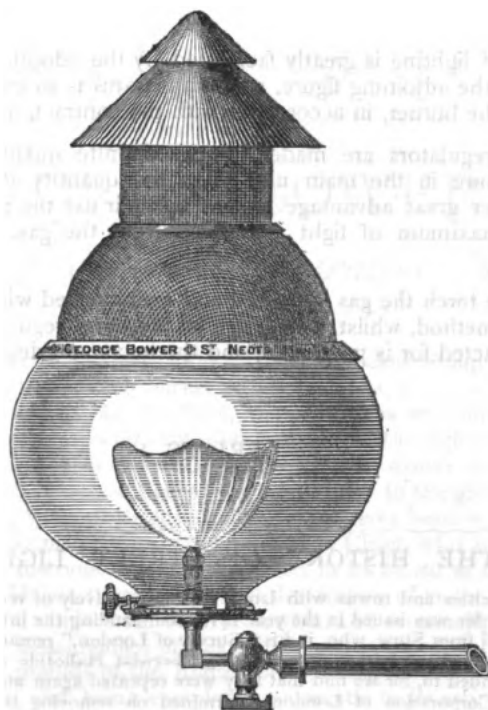

## THE PUNKAH TOP.

Although designed especially for use in India, or the tropics, for preserving a steady light in the lamps of a room in which the "punkah" is in operation, it is equally well adapted for fixing over the lamps of lobbies, halls, or any exposed position. The frame and caps are of brass, the frame being filled in with gauze, and they can be made to fit any sized globe.

## TORCHES FOR LIGHTING LAMPS.



The plan of lighting street lamps now most universally adopted is by means of a torch placed on the end of a rod; but for the purpose it is necessary to have an apparatus constructed so that the light is well protected and not liable to be extinguished by rain or strong currents of wind, but at the same time to be ready for instant use.

The apparatus here shown effects the object perfectly: the interior is fitted with an oil lamp, protected by double casings perforated in such a manner as to supply the flame with air for combustion, and removing the products of combustion without any liability of its being extinguished.

The stop-cocks attached to the street lamps are each provided with a double lever, of the form of an L, so arranged that one arm is always in a horizontal position.

The lamplighter first pushes up the horizontal arm of the lever with the top of the torch, thus turning on the gas: he then pushes up the torch through the bottom of the lantern, bringing it into close proximity with the burner, when the issuing gas enters the perforations and becomes ignited.

When the lamp is to be extinguished the other arm of the lever, which is horizontal, is pushed up: in this case, however, it is unnecessary to use the torch, a rod only being all that is required for the purpose.

By means of this contrivance the lamplighter is enabled to light 120 lamps in the same time in which he can light 80 lamps with a ladder, and with much less labour. The ladder is only required when the lamps are to be cleaned.

LANTERN HOLDERS, IN CAST, OR MALLEABLE IRON.

LANTERN COCKS, WITH LEVERS FOR OPENING OR CLOSING BY MEANS OF A ROD.

LANTERN FITTINGS OF EVERY DESCRIPTION.

GEORGE BOWER, ST. NEOTS, HUNTINGDONSHIRE.

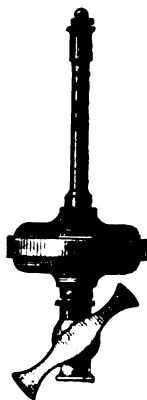

This system of lighting is greatly facilitated by the adoption of the lamp regulator, one form of which is shown in the adjoining figure, which apparatus is so constructed as to control the quantity of gas consumed by the burner, in accordance with the contract, and prevent loss to the company.

Street lamp regulators are made for any definite quantity—say 4, 4½, or 5 ft. per hour, and however the pressure in the main may vary, the quantity for which they are constructed is not exceeded. Another great advantage is that by their use the pressure of the gas is diminished to the degree that the maximum of light is derived from the gas, and for which purpose suitable burners are supplied.

Thus with the torch the gas is lighted and extinguished with greater facility and rapidity than by the old-fashioned method, whilst by the use of the lamp regulator any excessive consumption of gas beyond that contracted for is prevented, and the maximum degree of light is evolved by the gas.

### PRICES.

### THE HISTORY OF STREET LIGHTING.

A systematic method of lighting cities and towns with lamps is comparatively of recent introduction, as according to Maitland, in his "History of the Metropolis," an order was issued in the year 1414, commanding the inhabitants to hang out lanterns for the benefit of passers-by. This information is derived from Stow, who, in his "Survey of London," remarks, that in 1417, Sir Henry Barton, the Mayor, ordained lanthorns with lights to be hanged out in the winter evenings, betwixt Hallotide and Candlemasse." It does not appear, however, that these orders were much attended to, for we find that they were repeated again and again over a period of three hundred years. At the expiration of that time, the Corporation of London determined on removing the service altogether out of the hands of the inhabitants; they therefore entered into contract with a person to set up the public lights, and to attend properly to them—for which they gave him permission to charge six shillings a-year to every householder whose annual rent exceeded ten pounds. In 1736, the Lord Mayor and Common Council applied to Parliament for power to light the streets in a better manner. This power was further increased in 1744; and from that time the illumination of the city gradually improved; however, as hereafter remarked at the period of the introduction of gas lighting, the illumination of the streets of London was of the most dismal description.

In the year 1558 Paris was lighted by huge contrivances called *falots*, which were erected in the principal thoroughfares. The *falot* was a sort of vase filled with pitch, resin, and similar substances in a state of combustion; but it was soon found that this mode of lighting the streets was expensive, dangerous, and inconvenient, and consequently the *falot* was quickly displaced by the lantern, which was a rude frame covered with horn or varnished leather. For more than a hundred years this was the plan of illumination generally adopted; and as may be supposed, the light was too feeble for any useful purpose; indeed, no one of importance ventured abroad after dark without his torch or flambeau. The latter, therefore, became so indispensable to the midnight traveller, that an ingenious Italian, named Laudati, conceived the idea of opening stalls for their hire. He started his business in Paris, in the month of March, 1662, and he managed it so well that he obtained the entire monopoly of the whole city; his charge for a link was from three to five sous the quarter of an hour, according to the rank of his customer, and to avoid disputes each link boy carried an hour glass.

This system appears to have been introduced into England, as we find it stated in the "Fortunes of Nigel," by Sir Walter Scott:—"The generation of link boys celebrated as peculiar to London had already, in the reign of James the First, begun their functions;" he also describes in another work how the coaches of the aristocracy were about that time accompanied with link men.

In 1667, Nicholas de Reynis, the first Lieutenant-General of police, introduced lamps of glass, which from their resemblance to a bucket were called *lanternes àseau*. These he fixed in the middle of the streets, exactly in the same way as they were recently suspended in many parts of France, by means of ropes or wires fixed at each side of the street.

This was improved upon about a century afterwards by Lavoisier, who introduced the reverbère lamp, and among the other systems he proposed, was candles enclosed in tubes, actuated by spiral springs similar to the modern carriage lamp; and from the drawings and details entered into we may assume that the adaptation or invention was original.

Within the memory of some persons living sedan chairs were in use for conveying the gentry about the Metropolis during the night, each chair being carried by two men, and accompanied by two others who carried links or torches, and such was the importance attached to these linkmen, that houses of a superior description were provided with extinguishers at their entrances for the torches. At that time the streets were lighted (if the term may be applied) by lamps, each of which was formed by a simple twisted cotton wick dipping into oil, enclosed in a glass globe of large dimensions, and many of these globe frames and torch extinguishers are still to be seen in various parts in London. At that time linkmen attended in numbers at the theatres on the termination of the performance to accompany those who were there to hire them. Watchmen, in most cases old and decrepid, armed with a rattle to give alarm, and an immense horn lantern, as represented in some of Hogarth's pictures, were then the only guardians of the night. Then the ordinary means of lighting were either by the candle or oil lamp with the twisted cotton wick. As regards the candle, within the memory of elderly people the snuffers were an accompaniment to every table, and in places, such as churches and chapels, an individual was specially appointed as "candle-snuffer;" the importance of this defect of the candle began to be recognized about the period of the first establishment of gas, as we find a large portion of Acum's first Treatise of Gas devoted to improvements in candles with the view of avoiding snuffing.

| THE NUMBER OF PUBLIC LAMPS IN LONDON IN 1874. |   |        |
|-----------------------------------------------|---|--------|
| The Imperial Company supplied                 | . | 16,984 |
| „ Chartered „                                 | „ | 15,000 |
| „ Phoenix „                                   | „ | 5,497  |
| „ London „                                    | „ | 4,821  |
| „ Commercial „                                | „ | 3,706  |
| „ South Metropolitan „                        | „ | 3,666  |
| „ Surrey Consumers „                          | „ | 1,949  |
| „ Independent „                               | „ | 1,507  |
| „ Ratcliff „                                  | „ | 170    |
| Total                                         | . | 53,300 |

[P]

## CONSUMERS' METERS,

MANUFACTURED BY

### GEORGE BOWER,

*Gas and Water Engineer and Contractor, St. Neots, Hunts.*

During several years after the first establishment of gas, the usual means of supplying it was by contract, that is, the consumer paid a certain sum per quarter for each burner on his premises, supposed to be lighted from sunset to the hour agreed upon according to arrangement. At that time, the use of gas was confined entirely to shops, where the burners could be seen by the gas company's inspector, but often, instead of the lights being extinguished on closing the premises, they were kept alight in some instances the whole of the night in winter, to warm the locality; moreover, in some cases where not exposed to view, the gas was lighted during the day to the great prejudice of gas companies, and in the absence of the meter, gas lighting, with all its advantages, would have been very limited in its use.

The first attempts at supplying gas by meter were made by Samuel Clegg, who, in 1815, obtained a patent for what he termed a rotative gas meter; but the instrument was so imperfect in its action as to render it next to useless for the purpose. Two years afterwards, John Malam invented another description of meter, and this, by the combined talents of Clegg and his partner Samuel Crosley, underwent some alteration, and eventually was transformed into the instrument now universally adopted for the measurement of gas, which was accomplished in the early part of 1821. The excellence of that instrument in all the grounds of the limited pressure required to work it, the steadiness of the lights it supplied, its accuracy of measurement, and being completely automatic in its action, are well understood and appreciated, and such was the degree of perfection attained at that early date, that, although innumerable patents have been since obtained for improvements in the instrument, it remains practically, with one or two notable exceptions, in the same state as when first invented. On the introduction of dry meters, hereafter referred to, the meter in question was called for distinction the "Wet Meter."

Unquestionably the best kind of meter for the interests of a gas company, on account of its durability, simplicity of parts, and certainty of action, is the wet meter, and the best of this kind are those with cast-iron cases.

The part of wet meters most speedily destroyed, when made of tinned iron, is the outer cases; and these cases, in some instances, after being in the company's store for some months, have been perforated actually before they were used; and even when in use with tin plate cases, the valve box, or the division plate separating the square frame from the whole case, is frequently perforated by oxidation after a brief service, when the meter is rendered inoperative.

The knowledge of these serious defects induced me years ago to make all the smaller kinds of meters with cast-iron cases, and experience has proved the great advantages to be derived therefrom by gas companies, the more particularly when supplied to gas-works abroad, where often the expense of repairing tin-plate cased meters forms an important item in their accounts.

In the construction of these meters all complexity of mechanism is avoided; all the internal parts of them are formed of incorrodible metal; they work with a minimum of pressure, and for accuracy of measurement they can be strictly relied on.

### CONSUMERS' WET METERS.

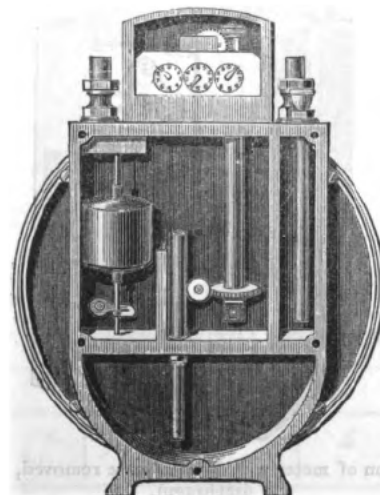

GEORGE BOWER, ST. NEOTS, HUNTINGDONSHIRE.

CAPACITY AND PRICES OF WET METERS.

| No. of Lights the Meter will supply at 5 Cubic Feet per Hour. | Measuring Capacity. |             | Size of Inlet.  | Prices. |    |    |
|---------------------------------------------------------------|---------------------|-------------|-----------------|---------|----|----|
|                                                               | Per Revolution.     | Per Hour.   |                 | £       | s. | d. |
| Lights.                                                       | Cubic Feet.         | Cubic Feet. | Inches.         |         |    |    |
| 2                                                             | $\frac{1}{16}$      | 10          | $\frac{1}{2}$   |         |    |    |
| 3                                                             | $\frac{1}{8}$       | 15          | $\frac{3}{4}$   |         |    |    |
| 5                                                             | $\frac{1}{4}$       | 25          | 1               |         |    |    |
| 10                                                            | $\frac{1}{2}$       | 50          | 1               |         |    |    |
| 20                                                            | 1                   | 100         | 1 $\frac{1}{4}$ |         |    |    |
| 30                                                            | 1                   | 150         | 1 $\frac{1}{2}$ |         |    |    |
| 50                                                            | 2                   | 250         | 2               |         |    |    |
| 80                                                            | 4                   | 400         | 2 $\frac{1}{2}$ |         |    |    |
| 100                                                           | 5                   | 500         | 2 $\frac{1}{2}$ |         |    |    |
| 200                                                           | 10                  | 1000        | 3               |         |    |    |

APPLICATION OF GLYCERINE TO GAS METERS.

Among the many useful applications of glycerine, few have surpassed in practical utility the substitution of glycerine for water in gas meters. The inconveniences attendant on the use of water in gas meters are, as is well known, very great. Its evaporation during summer, and its congelation during winter, rendered it most desirable to substitute a fluid on which extremes of temperature should have no such influence. M. Barresvill has discovered, and has adopted as a substitute, a solution of glycerine, which he finds is not affected either by extreme heat of summer or by the greatest amount of cold to which gas meters may, under ordinary circumstances, be subjected during the winter months. The results obtained from a series of experiments prove that it is only necessary to employ a solution of glycerine of such a degree of concentration that it shall contain from 40 to 45 per cent. of anhydrous glycerine, which solution will have a density of from 1.105 to 1.117, in order that those inconveniences which are attendant on the use of water may be entirely surmounted.

DRY METERS.

In some localities the dry meter is preferred, and perhaps this preference is given by gas-fitters who have less labour in fixing it, and by the absence of water in this meter there is not the liability of any condensed liquid collecting in the fittings, and causing obstructions or oscillations of the lights, which occurs sometimes with the wet meter. Lastly, with dry meters frost is not likely to affect them. These, and other reasons, have induced many fitters and several companies to adopt the dry meter; but there are many companies who are entirely opposed to its use, principally on account of their limited duration as compared with the wet meters, and more particularly those with cast-iron cases.

The cases of dry meters are usually made of tinned plates; the flexible material is composed of the best tanned skins, and all the smaller parts are of incorrodible metal, and the system of manufacture adopted is that which the experience of upwards of thirty years has proved to be the best.

All meters of either kind used in the United Kingdom are required to be tested by Government, or other appointed officials, and on being found correct are legally stamped. For places abroad this is not absolutely necessary; but in many cases it may be advisable, when the measurement is by the English cubic foot, to have the meters duly stamped, which will convey a stronger impression of their reliability than if left unstamped.

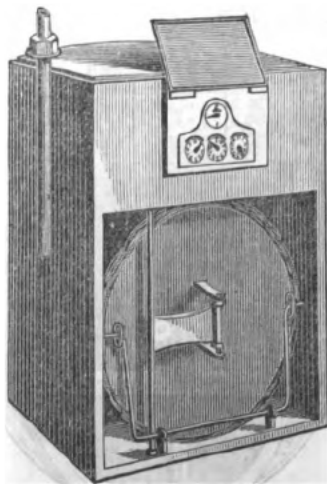

Elevation of meter with front of case removed, showing diaphragm.

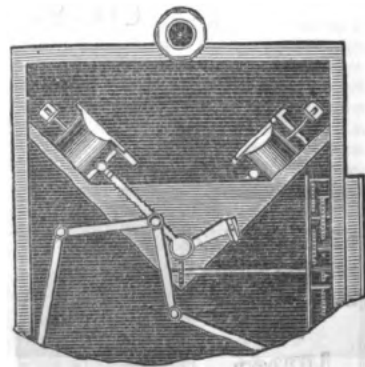

Part plan, with top of case removed, shewing arrangements of the valves and levers which communicate with the diaphragm; and the worm, wheels, and spindles which give motion to the index.

CONSUMERS' DRY METERS.

CAPACITY & PRICES OF DRY METERS IN TIN-PLATE CASES.

| No. of Lights the Meter will Supply at 6 Cubic Feet per Hour. | Measuring Capacity. |             | Size of Inlet & Outlet. | Price per Meter. |    |    |
|---------------------------------------------------------------|---------------------|-------------|-------------------------|------------------|----|----|
|                                                               | Per Revolution.     | Per Hour.   |                         | £                | s. | d. |
| Lights.                                                       |                     | Cubic Feet. | Inches.                 |                  |    |    |
| 1                                                             | 0.33                | 6           | 1                       |                  |    |    |
| 2                                                             | 0.83                | 12          | 1 1/4                   |                  |    |    |
| 3                                                             | 1.25                | 18          | 1 1/2                   |                  |    |    |
| 5                                                             | 2.02                | 30          | 1 3/4                   |                  |    |    |
| 10                                                            | 3.3                 | 60          | 2                       |                  |    |    |
| 20                                                            | 6.6                 | 120         | 2 1/2                   |                  |    |    |
| 30                                                            | 9.9                 | 180         | 3                       |                  |    |    |
| 50                                                            | 16.5                | 300         | 3 1/2                   |                  |    |    |
| 60                                                            | 19.8                | 360         | 4                       |                  |    |    |
| 80                                                            | 26.4                | 480         | 4 1/2                   |                  |    |    |
| 100                                                           | 33                  | 600         | 5                       |                  |    |    |
| 150                                                           | 49.5                | 900         | 5 1/2                   |                  |    |    |
| 200                                                           | 66                  | 1200        | 6                       |                  |    |    |
| 250                                                           | 82.5                | 1500        | 6 1/2                   |                  |    |    |
| 300                                                           | 99                  | 1800        | 7                       |                  |    |    |
| 400                                                           | 132                 | 2400        | 7 1/2                   |                  |    |    |
| 500                                                           | 165                 | 3000        | 8                       |                  |    |    |

NOTE.—All meters for Great Britain are sent out stamped as the Sale of Gas Act requires, the mere cost being added to the Invoice as usual.

METERS MADE TO THE STANDARD OF ANY NATION.

EXPERIMENTAL OR TEST METERS.

These meters are provided with special indices to indicate to the 100th (or less) part of a foot, the long pointers making one revolution for every cubic foot of gas passed through the meter. All the pointers are made and fitted in such a manner that each can be moved back to "0" at the commencement of every experiment.

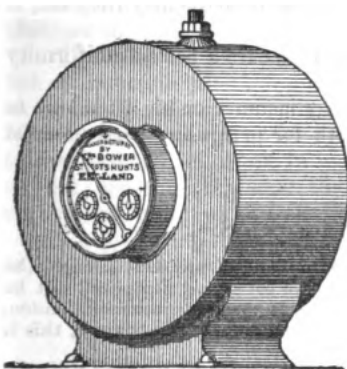

CAPACITY & PRICES OF EXPERIMENTAL & TEST METERS.

| No. of Lights. | Capacity per Hour. | Size of Inlet & Outlet. | Prices. |    |    |
|----------------|--------------------|-------------------------|---------|----|----|
| Lights.        | Cubic Feet.        | Inches.                 | £       | s. | d. |
| 3              | 15                 | 1                       |         |    |    |
| 5              | 25                 | 1 1/4                   |         |    |    |
| 10             | 50                 | 1 1/2                   |         |    |    |
| 20             | 100                | 2                       |         |    |    |

TEST GAS HOLDERS,

Of the most complete and perfect construction, with cycloidal compensation, gauges, thermometer, etc.

| Capacity in Cubic Feet. | 1 |    |    | 5 |    |    | 10 |    |    | 20 |    |    |
|-------------------------|---|----|----|---|----|----|----|----|----|----|----|----|
| Price of each           | £ | s. | d. | £ | s. | d. | £  | s. | d. | £  | s. | d. |
|                         |   |    |    |   |    |    |    |    |    |    |    |    |

GEORGE BOWER, ST. NEOTS, HUNTINGDONSHIRE.

GAS REGULATORS.

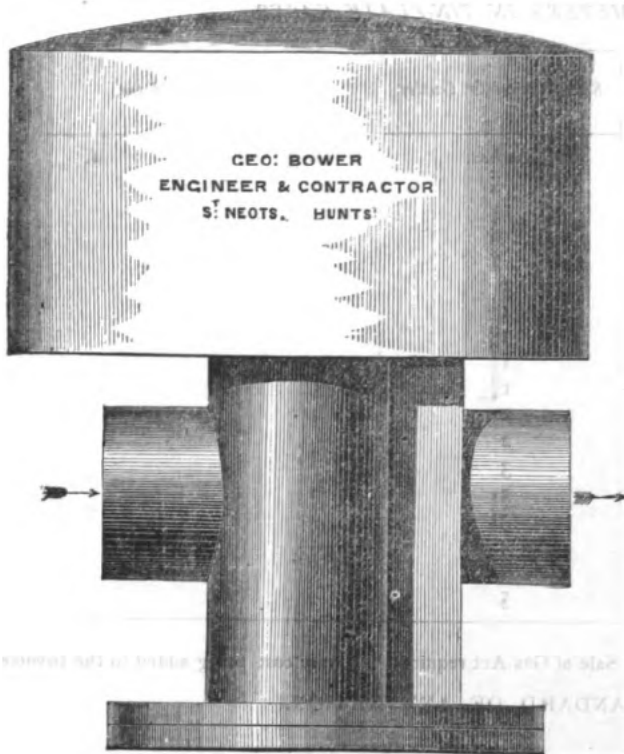

A description of Regulator, suitable for controlling the pressure in manufactories, theatres, dwellings, and other establishments, is represented in the following engraving.

This regulator is constructed on an approved principle, and consists of the outer tank of cast iron, and the bell or holder of wrought iron. The tank has an annular space charged with mercury, in which the bell floats. Attached to the bell are two cones, working in their corresponding valves, by which construction the inlet pressure is neutralized, thus preventing the oscillation caused by the action of the gas where only one valve exists. These instruments are of the greatest simplicity in their construction, require little attention, and are not liable to get out of order. They are fitted with the greatest degree of accuracy, and when once adjusted to the pressure required, it is maintained with the greatest nicety and precision, without regard to the number of lights burned on the premises where it is fixed, or the variation of the pressure in the company's main.

The saving afforded by the use of these Regulators is in all cases considerable, but entirely dependent on circumstances.

Also, on account of their unvarying steadiness and accuracy, they are well adapted for experimental purposes.

In ordering, it is necessary to give the sizes of the pipes to which the Regulators are to be attached.

Governors or Regulators have long been used for adjusting the supply of gas to the burners in factories, and other large buildings where the consumption is considerable.

As stated in Section I, their object is to produce a perfect uniformity of flame at all variations of pressure in the main.

When the supply of gas to the burner is attempted to be adjusted by partly closing the stopcock, the angle formed by the passage through it, with the supply pipes, deflects the current of gas against the side, and it consequently issues from the burner in the form of an irregular jagged flame. By the use of a regulator, the stopcock may be turned full on, and there being no obstruction to the passage of the gas, it burns with a more uniform and steady light, and there is a considerable increase in the illuminating power from this cause alone, even with the same consumption.

They have this advantage, also, when applied to street lamps, that the supply of gas is not left to the judgment of the lamplighter; the dissatisfaction arising from the stopcocks being only turned half on, as is frequently the case, is thus effectually prevented.

In buildings of several stories high, it is usual to fix a Regulator in each story, so as to secure a perfect uniformity of pressure throughout the whole establishment.

In order to adjust the Regulator to the proper degree of pressure, and enable the consumer or his attendant to ascertain at a glance if it is in working order, a Pressure Gauge should be fixed near it; for prices and particulars of which see Section K.

EFFECT OF PRESSURE ON THE CONSUMPTION OF GAS.

The pressure at which gas ought to be consumed is a point of considerable importance; for, if the amount of pressure be high, the gas will burn with a roaring noise, and will be consumed wastefully; whereas, if it be low, the fish-tail and bat's-wing flames will not be sufficiently spread out, and the light will be dim and smoky. Dr. Letheby states, in his Ninth Report to the Corporation of London, that gas ought to be delivered to the public at not less than half an inch of water pressure; and it may be said that, in practice, this is found to be the best pressure at which gas can be consumed.

Again, it is a matter of importance that the pressure at which gas is supplied should be as uniform as possible; for if at one time the pressure is great, and at another low, the burner requires great attention, in order that the flame shall be of one uniform height. Experiments have been made to determine the rate at which gas burns under different pressures; and as the results are somewhat important, they are tabulated below. In a general way, it may be said, that by doubling the amount of pressure, we increase the consumption of gas by about one-half.

| Burner.         | Pressure in inches of water. | Consumption per hour in cubic feet | Burner.         | Pressure in inches of water. | Consumption per hour in cubic feet. |
|-----------------|------------------------------|------------------------------------|-----------------|------------------------------|-------------------------------------|
| Single jet      | 0.30                         | 2.6                                | Large fish-tail | 0.48                         | 2.3                                 |
| "               | 0.60                         | 3.9                                | " bat's-wing    | 0.47                         | 3.3                                 |
| "               | 1.20                         | 5.2                                | "               | 0.70                         | 3.1                                 |
| Small fish-tail | 0.34                         | 1.4                                | "               | 1.40                         | 4.5                                 |
| "               | 0.77                         | 2.2                                |                 |                              |                                     |

GEORGE BOWER, ST. NEOTS, HUNTINGDONSHIRE.

[ Q ]

# GAS FITTINGS,

MANUFACTURED AND SUPPLIED BY

## GEORGE BOWER.

*Gas and Water Engineer and Contractor, St. Neots, Hunts.*

### GAS FITTING.

In consequence of the limited use of gas, together with the extraordinary care supposed to be required in its distribution, during many years gas fitting was confined to, and monopolized by a few firms in each town, who were "especially appointed" by the various gas companies. But as gas lighting became developed and introduced into dwellings, then the monopoly of the earliest gas fitters ceased. The business was open to be undertaken by all without distinction who were so disposed, and possessed the skill to conduct it. This arrangement was highly conducive to the interests of the companies, and to the advancement of gas lighting, inasmuch as every gas fitter is an interested agent for the company supplying.

The importance of the generalization of the branch of business in question is made obvious by the operations in the Metropolis and other large cities and towns, where, in the majority of new houses inhabited by the middle classes, and in those of a superior description, the pipes for conveying the gas to the different parts of the dwelling are placed at the time of building. Under these conditions, from authentic sources we learn that, in nine cases out of ten, in the houses of the middle classes gas is adopted, and only in one instance in about a hundred, is it dispensed with in larger dwellings; a highly satisfactory state of affairs that would never have been attained with a monopoly in the business.

For manufactories and other large buildings, as well as private dwellings, as a rule galvanised iron pipes for the fittings is adopted where the work is intended to be of a superior description; soft metal as tin, composition, and lead pipes are of great durability, except when in contact with very impure gas, but if not well supported they are likely to fall into recesses, or "bag," where an accumulation of water may collect and stop the passage of the gas. A great objection to their use, however, when placed beneath the flooring and other inaccessible places, is their liability to be gnawed and perforated by rats, which fact is mentioned by several writers.

According to the quantity of water collected in a pipe, so will the pressure of gas be effected; for instance, if we suppose a half-inch pipe to be "bagged," or having a recess half filled with water, then two or three lights might be supplied according to the pressure, but on adding a fourth, the lights would begin to oscillate, and with a fifth, the whole would be extinguished. Oscillations arise from the gas and water contending together in the pipe, the pressure of the gas agitating the water; an extinction is caused by the gas forcing the water to that height to choke, or entirely obstruct the pipe.

The effect of too small a pipe is, that a certain number of lights may be supplied by it, giving good full flames, but on increasing that number, the flames of the burners are diminished accordingly. To illustrate this:—let us suppose an hydraulic chandelier having four burners, with its supply pipe too small; when on lighting two burners, a sufficiency of gas would exist, but on lighting a third, the first would be reduced, and still further diminished on igniting the fourth burner. In short, in such a case the supply pipe would only be ample for two burners, consuming together say 10 feet; consequently, when three or four burners are lighted simply that quantity passes. Of course, it is assumed under all the circumstances that the same pressure is maintained.

The following table, extracted from "Molesworth's Engineers' Pocket Book," gives the maximum quantities of gas supplied under various pressures through pipes of different diameters. each of the pipes being 30 feet in length.

SUPPLY OF GAS IN FEET PER HOUR, PRESSURE IN TENTHS OF INCH AND DIAMETER OF PIPES, EACH BEING TEN YARDS LONG.

| Diameter of Pipe in Inches and Parts. | Tenths. |      |      |      |      |      |      |      |      |      |
|---------------------------------------|---------|------|------|------|------|------|------|------|------|------|
|                                       | 1       | 2    | 3    | 4    | 5    | 6    | 7    | 8    | 9    | 10   |
| $\frac{1}{8}$                         | 13      | 18   | 22   | 26   | 29   | 31   | 34   | 36   | 38   | 41   |
| $\frac{1}{4}$                         | 26      | 37   | 46   | 53   | 59   | 64   | 70   | 74   | 79   | 83   |
| $\frac{3}{8}$                         | 73      | 103  | 126  | 145  | 162  | 187  | 192  | 205  | 218  | 230  |
| 1                                     | 149     | 211  | 258  | 298  | 333  | 365  | 394  | 422  | 447  | 471  |
| $1\frac{1}{4}$                        | 260     | 368  | 451  | 521  | 582  | 638  | 689  | 737  | 781  | 823  |
| $1\frac{1}{2}$                        | 411     | 581  | 711  | 821  | 918  | 1006 | 1082 | 1162 | 1232 | 1299 |
| 2                                     | 843     | 1192 | 1460 | 1686 | 1886 | 2066 | 2231 | 2380 | 2530 | 2667 |

From this we learn that a pipe  $\frac{3}{8}$  of an inch in diameter, when in a straight line, with a pressure of  $\frac{1}{4}$ ths will deliver 29 feet, or a one-inch pipe 323 feet per hour, all the rest corresponding ; but in consequence of the accidental obstruction by condensation, or the pipe being accidentally reduced in capacity at any point, it is better to increase these sizes considerably ; a further reason for this recommendation consists in the uncertainty of the pressure at some periods in the company's main.

It is usually estimated that the pressure of gas increases  $\frac{1}{4}$ th of an inch for every 10 feet of increased elevation. Thus, if we suppose a main in one part of a town to be 60 feet higher than at another, or a building having its highest floor that elevation above the basement, then if the pressure be  $\frac{1}{4}$ ths at the lower points, it would be augmented by the ascensive nature of the gas to  $\frac{1}{2}$ ths at the higher points, alike of a town or building. This, however, is only the case where the lights are not ignited, and there is no draught of gas ; but whenever the whole of the burners on a line of main, or in a building, are brought into use, the conditions are changed, for should the pipes for the lower parts be too ample, and those supplying the higher places be too small, then the lights of the lower part would be well supplied, whilst the opposite would be the case in the upper part of the town or building.

An indispensable instrument for every gas company, and particularly those who are troubled with naphthaline, is the "Service cleaner," the object of which is clearly indicated by its name. This consists of an air pump attached and connected to an air-tight chamber, which is provided with a tap, and when required for operation, this tap is connected to the obstructed service by means of an india-rubber tube. This effected, the air is compressed into the chamber by the pump to the desired degree, when the tap is suddenly opened the air rushes out and clears the obstacle from the service.

BOOKS AND PRICES OF EVERY VARIETY OF DESIGNS FOR  
WATER-SLIDE AND CORK-SLIDE GASELIERS, PENDANTS, BRACKETS,  
HALL AND PASSAGE LAMPS, PILLARS, SUN-LIGHTS, STAR-LIGHTS,  
MEDIÆVAL FITTINGS SUITABLE FOR CHURCHES, ETC.,  
FORWARDED ON APPLICATION.

GAS STANDS, WITH FLEXIBLE TUBE, ETC.  
GAS SHADES, OR MOONS.

GAS REFLECTORS.  
ILLUMINATION DEVICES.

APPARATUS FOR TESTING THE SOUNDNESS OF GAS FITTINGS.

BAMBOO RODS AND TORCHES FOR LIGHTING GASELIERS, SUN-BURNERS, ETC.  
FLEXIBLE TUBING, PLAIN AND GLAZED.  
WOOD BLOCKS OR PATRESSES.

CARTER'S VALVES . . .  $\frac{1}{2}$ -in. . .  $\frac{3}{4}$ -in. . . 1-in. . .  $1\frac{1}{4}$ -in. . .  $1\frac{1}{2}$ -in. . . 2-in.  
Prices . . . . .

COST OF GAS PER HOUR,

WHEN BURNT AT THE FOLLOWING RATES PER 1000 CUBIC FEET, IN FRACTIONS OF A PENNY.

| Burner consuming<br>in cubic ft. per hour | 3s  | 4s  | 4s 6d | 5s  | 5s 6d | 6s  | 6s 8d | 7s  | 7s 6d | 8s  | 9s  | 10s | 11s | 12s | 13s | 14s | 15s | 16s | 17s  |
|-------------------------------------------|-----|-----|-------|-----|-------|-----|-------|-----|-------|-----|-----|-----|-----|-----|-----|-----|-----|-----|------|
| 2                                         | 072 | 096 | 108   | 120 | 132   | 144 | 160   | 168 | 180   | 192 | 216 | 240 | 264 | 288 | 312 | 336 | 360 | 384 | 408  |
| 2½                                        | 090 | 120 | 135   | 150 | 165   | 180 | 200   | 210 | 225   | 240 | 270 | 300 | 330 | 360 | 390 | 420 | 450 | 480 | 510  |
| 3                                         | 108 | 141 | 162   | 180 | 198   | 216 | 240   | 252 | 270   | 288 | 324 | 360 | 396 | 432 | 468 | 504 | 540 | 576 | 612  |
| 3½                                        | 126 | 168 | 189   | 210 | 231   | 252 | 280   | 294 | 315   | 336 | 378 | 420 | 462 | 504 | 546 | 588 | 630 | 672 | 714  |
| 4                                         | 144 | 192 | 216   | 240 | 264   | 288 | 320   | 336 | 360   | 384 | 432 | 480 | 528 | 576 | 624 | 672 | 720 | 768 | 816  |
| 4½                                        | 162 | 216 | 243   | 270 | 297   | 324 | 360   | 378 | 405   | 432 | 486 | 540 | 594 | 648 | 702 | 756 | 810 | 864 | 918  |
| 5                                         | 180 | 240 | 270   | 300 | 330   | 360 | 400   | 420 | 450   | 480 | 540 | 600 | 660 | 720 | 780 | 840 | 900 | 960 | 1020 |

BURNERS.

During many years after the introduction of gas lighting, the most suitable burners for the consumption of gas was utterly disregarded, as the general impression existed that a given quantity and quality of gas always gave the same degree of light, regardless of the pressure with which the gas issued, the orifices for the admission of air, or the height of the chimneys of argand burners, or other controlling influences ; and only within the last few years has any correct information on the subject been acquired.

GEORGE BOWER, ST. NEOTS, HUNTINGDONSHIRE.



The essentials for a good burner are, that its orifices shall be sufficiently large to permit of the quantity of gas for which it is constructed to pass at a feeble pressure; that its orifices should be kept clear, in order that the gas may issue in a uniform and regular flame; that the inner and annular passages for the current of air in the argand burner, as well as the height and diameter of the chimney, shall correspond with the quantity and quality of the gas consumed. To give a practical illustration of the misapplication of gas: if the orifice or orifices of any kind of burner be made of very limited dimensions, thus demanding great pressure to expel the gas, only a limited degree of light will be evolved; and by diminishing the orifices to the extent that three or four inches pressure are necessary to expel the gas, then no light whatever is yielded by the gas, identical in effect to the Bunsen burner, and arising from the same cause, namely, an excess of oxygen intermixing with the gas.

The burners now generally employed in gas lighting are, the Argand, Bat's-wing, and Fishtail, or, as frequently called, the Union Jet; and on rare occasions, the Single Jet. Formerly, the three latter, as well as the part of the argand whence the gas issues, were made of iron or steel; but, in consequence of the tendency of these metals to corrode rapidly, and obstruct the passage of the gas, they were replaced by other silicious materials, known as "Adamas," or "Steatite," of which all fishtail and bat's-wing burners, as well as the points for the issue of the gas in arganda, are now universally made.

**PATENT GAS BURNERS.**

**PATENT BAT'S-WING BURNERS, WITH TAPER SCREWED SOCKETS.**

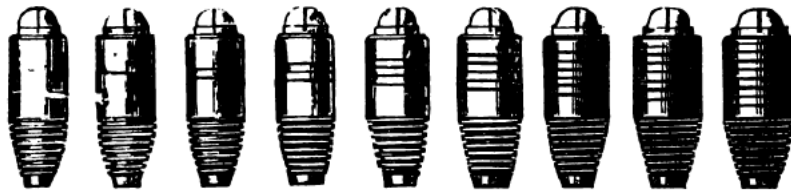

**PATENT UNION-JET OR FISHTAIL BURNERS, WITH TAPER SCREWED SOCKETS.**



**PATENT UNION-JET BURNERS, WITH TAPER SCREWED SOCKETS, FOR CANNEL COAL GAS.**

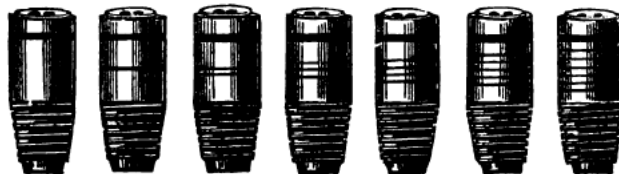

**PATENT UNION-JET BURNERS, WITH PLUG SOCKETS, FOR SCOTCH CANNEL COAL GAS.**

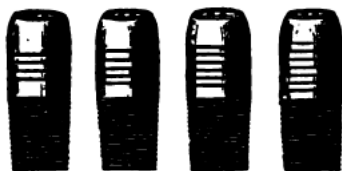
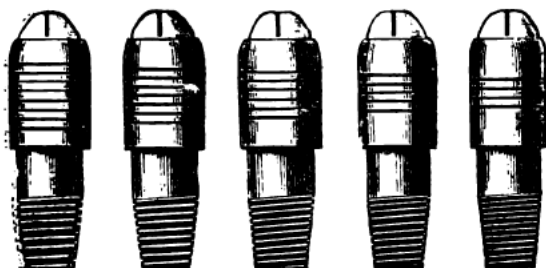
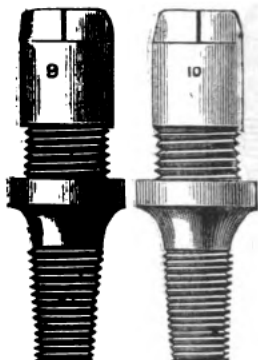
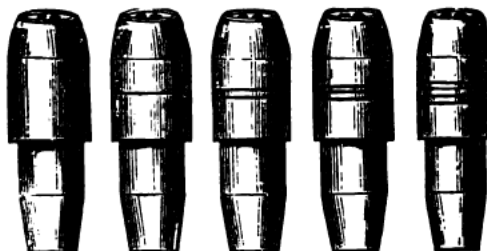

*GEORGE BOWER, ST. NEOTS, HUNTINGDONSHIRE.*

PATENT UNION-JET BURNERS, IN BRASS SOCKETS  $\frac{1}{4}$  SCREW ONLY.BAT'S-WING ECONOMISERS, FOR COMMON  
COAL GAS ONLY.UNION JET ECONOMISERS' PLUG, FOR  
SCOTCH CANNEL COAL GAS.

BRITISH STANDARD BURNERS, made to consume 4, 5, 6, 7, 8, 9, and 10 feet of gas, at pressure from  $\frac{1}{8}$  of an inch to  $1\frac{1}{2}$  inch. Heat, blacks, and soot are entirely avoided. Complete with triangle, to fit globes, cups, etc., each Burners without triangles, each

BURNERS in Steatite.

BAT'S-WINGS, to consume any quantity per hour, from 2 feet to 12 feet,

UNION JETS, from  $1\frac{1}{2}$  feet to 6 feet.

BRASS BURNERS.

per gross.

"

"

It should be observed, that whatever may be the quality of the gas, the degree of illuminating power evolved therefrom will be influenced in a remarkable degree by the kind of burners employed; as with burners having very small orifices, and the gas supplied with heavy pressure, such as exists in almost every gas works, under these conditions the gas will be burnt without giving any available light. The maximum degree of light obtained by bat's-wing and union jet burners with Newcastle coal gas is, when the issues at the point of combustion are at a pressure of about  $\frac{1}{8}$ ths; the orifices of well-made burners being adjusted to that. For cannel gas, the orifices of the burners are required to be smaller than those mentioned; therefore, when ordering burners to consume cannel gas, this should be stated.

ORDINARY PLAIN AND CRUTCH ARGAND BURNERS.

PATENT STANDARD ARGAND OR LONDON BURNERS.

DOUBLE AND TREBLE RING ARGAND BURNERS.

THREE, FIVE, AND SEVEN SPRAY BURNERS.

20 TO 200 CANDLE BURNERS FOR STREET LIGHTING.

STAR BURNERS. SUN BURNERS.

BUNSEN'S GAS AND AIR BURNERS OF VARIOUS PATTERNS AND SIZES FOR HEATING  
AND COOKING PURPOSES.

RING BURNERS OF EVERY VARIETY FOR BILLIARD LIGHTS.

GEORGE BOWER, ST. NEOTS, HUNTINGDONSHIRE.

[R]

# GAS HEATING & COOKING STOVES,

MANUFACTURED AND SUPPLIED BY

## GEORGE BOWER,

*Gas and Water Engineer and Contractor, St. Neots, Hunts.*

The use of gas has now become very general for heating and cooking purposes; and in many instances, and under certain circumstances, it is more economical and convenient than the direct use of coal. These stoves are generally fitted with the atmospheric burner, by which means the gas is intermixed with air at the moment of ignition, producing a blue flame, practically devoid of light, but in which all the calorific powers of the gas are developed, avoiding the emission of smoke, and consequently the loss of gas, together with the oppressive odour which arises from the ordinary jet burner.

It may be observed, however, that all gas stoves should be provided with a small pipe, leading into a chimney or flue of some description, for the purpose of carrying off the products of combustion.

The following engravings represent a variety of heating and cooking stoves, each of which is described as to its dimensions and method of construction, with the letter or number of reference to indicate price:—

### GAS COOKING STOVES.

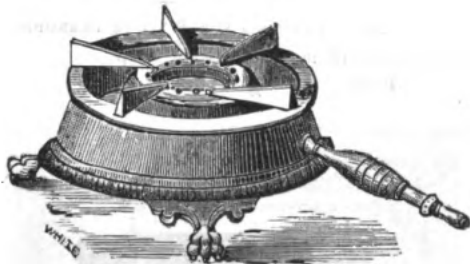

BOILING STOVES.

- |        |        |                  |
|--------|--------|------------------|
| No. 1. | 4½ in. | diameter of top, |
| " 2.   | 5½     | " "              |
| " 3.   | 6½     | " "              |
| " 4.   | 7      | " "              |



STEWING APPARATUS.

For cooking Chops, Frying, Boiling, or Toasting Bread.  
Price, all complete,

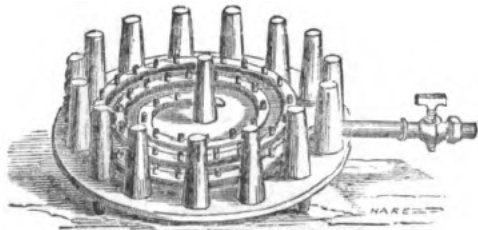

PATENT BOILER.

Nos. 1, 2, 3. Price

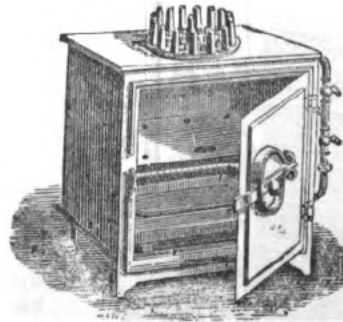

BACHELOR'S OVEN,  
WITH ONE BOILER.  
Price

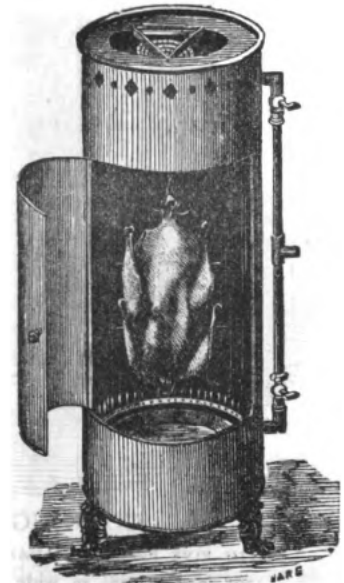

CYLINDRICAL COOKING STOVE, No. 1.  
32½ in. high, 11 in. diameter.

Made of wrought iron, with cast feet, well adapted for a small family or single person: will boil on the top. Price, with shelf,



ETNA,

WITH GAUZE-WIRE BURNER.

No. 1, 6½ in.—No. 2, 9 in., diameter.



**COOKING STOVE, A.**

WITH TWO BOILERS. ADAPTED FOR 6 TO 8 PERSONS.  
 25½ in. high, 17½ in. wide, 13 in. deep.  
 Price . . . £

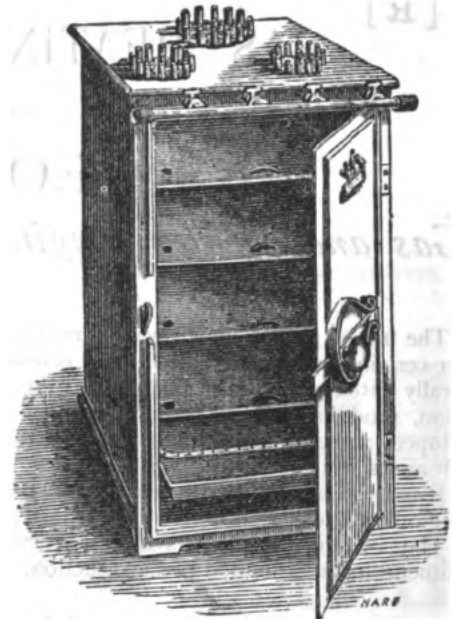

**COOKING STOVE, B.**

WITH THREE BOILERS. ADAPTED FOR 8 TO 14 PERSONS.  
 30½ in. high, 18 in. wide, 20½ in. deep.  
 Price . . . £

GAS  
 COOKING  
 STOVES.

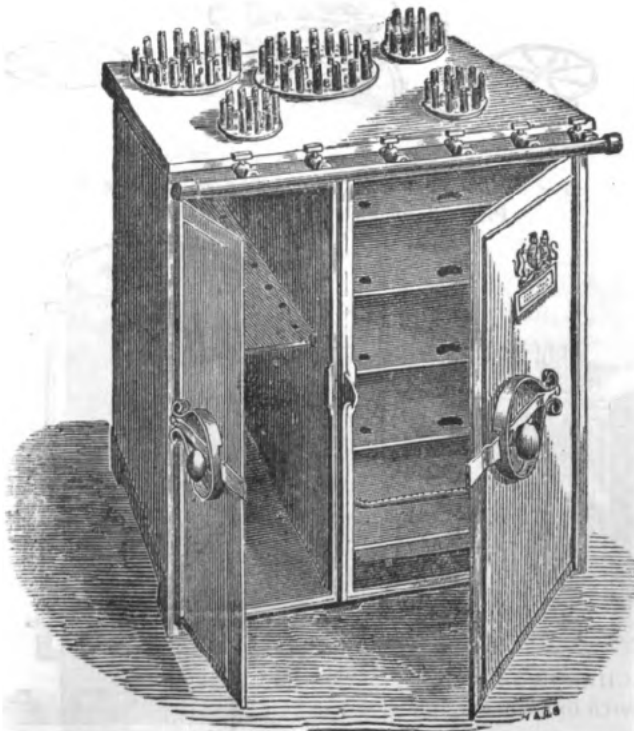

**COOKING STOVE, C.**

WITH FIVE BOILERS. ADAPTED FOR 10 TO 12 PERSONS.  
 30½ in. high, 28½ in. wide, 23 in. deep, with hot closet.  
 Price . . . £



**COOKING STOVE, No. 102.**

ADAPTED FOR 8 TO 12 PERSONS.  
 33½ in. high, 18½ in. wide, 17½ in. deep.  
 Price . . . £

A similar stove to C, but fitted with roasting burner and shelves to both compartments, called D.  
 Price . . . £



COOKING STOVE, No. 100.

ADAPTED FOR 6 TO 8 PERSONS.

28 in. high, 13½ in. wide, 12 in. deep.

Price £

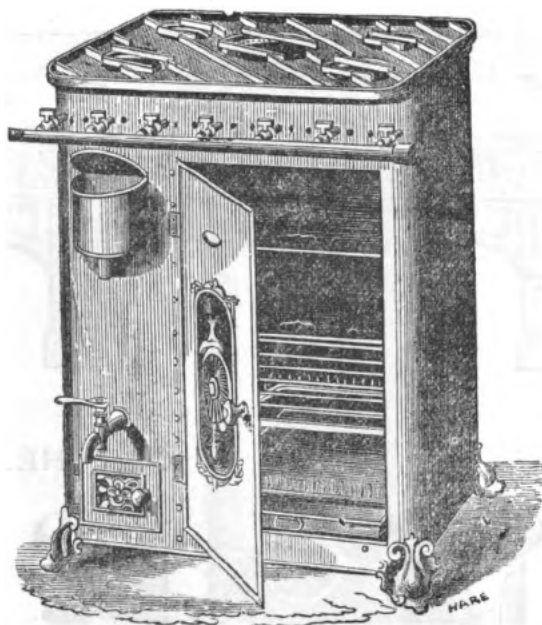

COOKING STOVE, No. 104.

ADAPTED FOR 10 OR 20 PERSONS. (Tin boiler to hold from 3 to 4 gallons.)

32½ in. high, 24½ in. wide, 18½ in. deep.

Price £

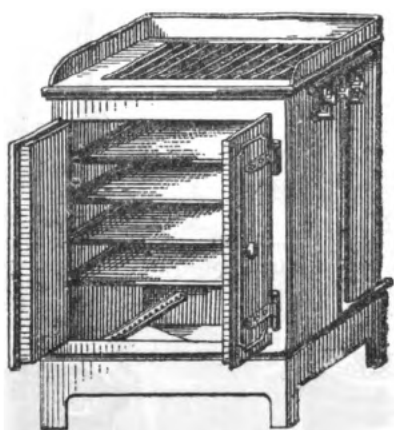

BAKING OVEN, E,

WITH BOILING AND STEWING APPARATUS ON TOP.

ADAPTED FOR 30 PERSONS.

Oven 2 ft. 3 in. high, 2 ft. 2 in. wide, 2 ft. 6 in. deep.

The Baking and Roasting Ovens E and F are fitted with an Outer Casing of Cast Iron. The Meat Oven is Lined with Enamelled Tiles, fitted with polished Steel Bars, with Sliding and Swivel Hooks, Tinned Dripping Pan, etc., complete.

Price £

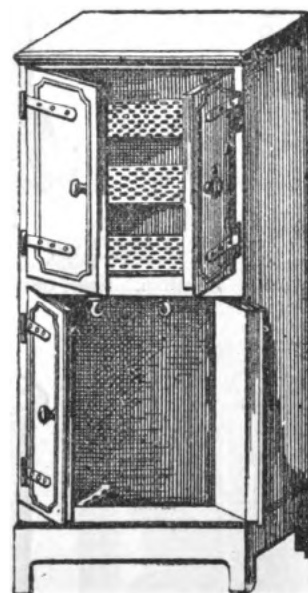

ROASTING AND BAKING APPARATUS, F.

ADAPTED FOR 50 PERSONS.

Meat Oven 2 ft. 10 in. high, 2 ft. 2 in. wide, 2 ft. 6 in. deep.  
Pastry Oven 2 ft. 3 in. " 2 ft. 2 in. " 2 ft. 6 in. "

Price £

Cooking Stoves A, B, C, and D, are made of wrought and cast iron, the sides and doors being double, thus forming an air chamber all round, and thereby preventing loss of heat.

Cooking Stoves 102, 104, and 100, are made of wrought and cast iron, with tin lining throughout. The door is fitted with an ornamental grating, in which may be placed a piece of talc or glass, enabling the cook to see that the gas is alight without opening the door. If the tin lining be kept bright, the stove will be more effective, on account of the radiation of heat.

GEORGE BOWER, ST. NEOTS, HUNTINGDONSHIRE.

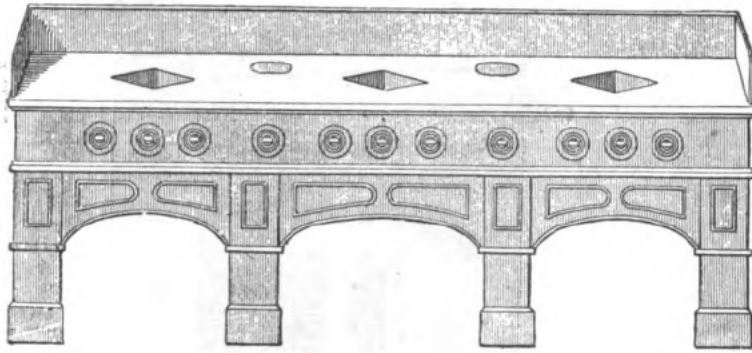

**GAS COOKING HEARTH,**

Strongly made of Cast Iron, fitted with Air Burners, Gas Tube, sunk Brass Plates, Cocks, etc., complete, made to any size, and furnished with Copper Boilers and Steaming Pans if necessary.

Prices for any size and description quoted on application.

**GAS HEATING STOVES.**

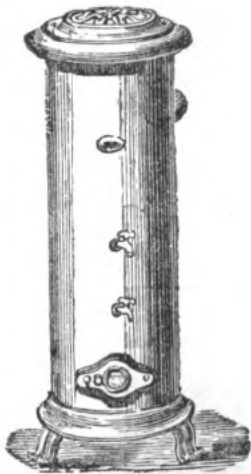

**HOT WATER STOVE,**  
PLAIN.  
26½ in. high; 7½ in. diameter.  
Wrought case, cast top & bottom.  
Price £

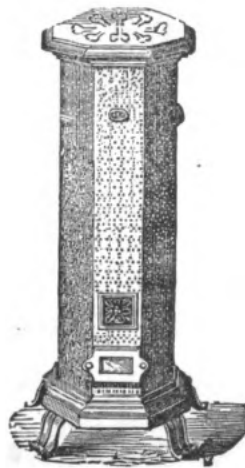

**No. 24.**  
27½ in. high, 7½ in. diameter.  
Wrought-iron case, with perforations, cast-iron top and bottom.  
Price £



**No. 23.**  
27½ in. high, 7½ in. diameter.  
Wrought-iron case, cast-iron top and bottom.  
Price £

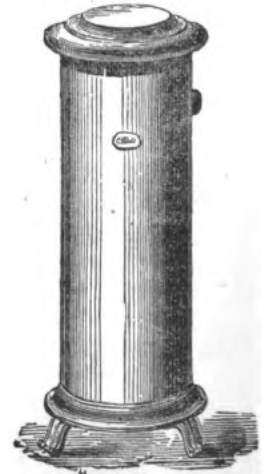

**No. 20.**  
27½ in. high, 7½ in. diameter.  
Wrought-iron case, cast-iron top and bottom.  
Price £

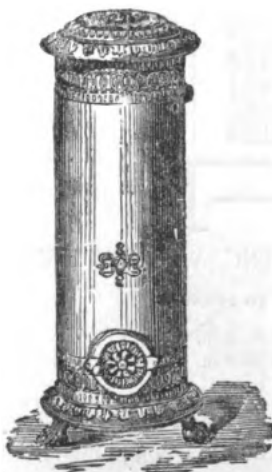

**No. 25.** GLASS IN DOOR.  
26½ in. high, 7½ in. diameter.  
Wrought-iron case, cast-iron top and bottom.  
Price £

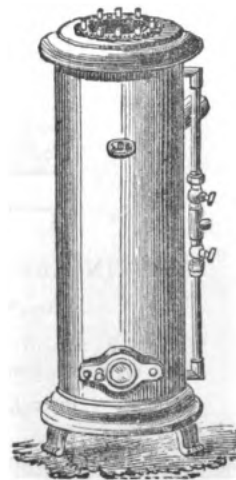

**No. 35.** GLASS IN DOOR.  
27½ in. high, 7½ in. diameter.  
Wrought-iron case, cast-iron top and bottom.  
Price £

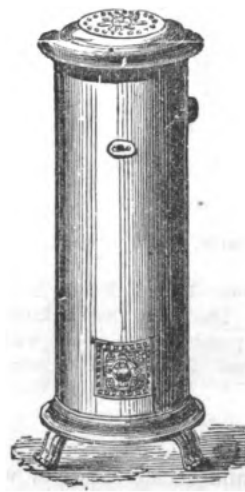

**No. 36.** DOOR TO LIFT OFF.  
27½ in. high, 7½ in. diameter.  
Wrought-iron case, cast-iron top and bottom.  
Price £



**HOT WATER STOVE,**  
ORNAMENTAL.  
26½ in. high, 7½ in. diameter.  
Wrought case, cast top & bottom.  
Price £



**No. 21.**  
43 in. high, 16 in. diameter.  
Cast-iron case.  
Price £

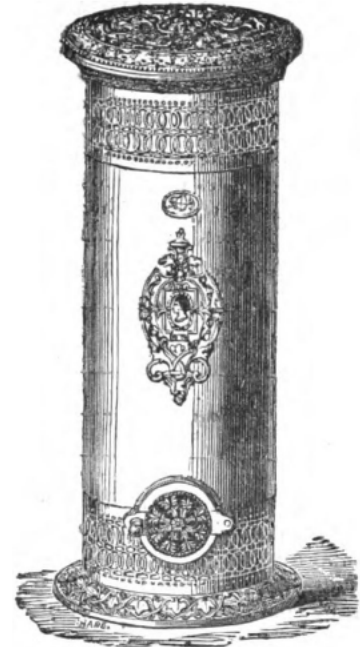

**No. 34. GLASS IN DOOR.**  
36 in. high, 11½ in. diameter.  
Wrought-iron case, with cast-iron top, bottom, and ornaments.  
Price £



**No. 37. DOOR TO LIFT OFF.**  
37 in. high, 8½ in. diameter.  
Wrought-iron case, cast-iron mountings, top, and bottom.  
Price £



**No. 38. DOOR TO LIFT OFF.**  
37 in. high, 8½ in. diameter.  
Wrought-iron case, cast-iron mountings, top, and bottom.  
Price £

## THE ADVANTAGES OF GAS FOR COOKING PURPOSES.

In addition to the advantages which gas presents as an economical means of illumination, it is also applicable as a cheap and extremely convenient substitute for ordinary fuel. Under certain conditions and with properly arranged apparatus it competes favourably with coal for the purposes of cooking, and when a fire is required only occasionally and for a short time, it has an undoubted advantage over coal as to cost and convenience. By the use of the "Atmospheric Burner," the gas is mixed with atmospheric air at the moment of ignition, producing a blue flame of great heat, which does not deposit carbon or soot as gas would if burnt through the ordinary burner.

The following statement, which was the result of many experiments, shows the relative cost of boiling a gallon of water in a copper kettle by means of a recently lighted coal fire, and by a gas stove, and the time required in each case:—

|           | Coals used.                       | Wood used. | Time employed. | Total Cost.   |
|-----------|-----------------------------------|------------|----------------|---------------|
| With Fire | 4½ lbs.                           | ½ of 1d.   | 1 hour         | 17/100 of 1d. |
| With Gas  | 4 cubic feet at 4s. 6d. per 1000. |            | 20 minutes.    | 1/100 of 1d.  |

It appears, therefore, that for such occasional purposes there is a saving of nearly 3½ to 1 in money and an economy of ¾ in time by the use of gas, in addition to the saving of trouble in lighting the fire, and the avoidance of smoke and dust.

The following gives the result of some experiments made by Mr. Magnus Ohren, and gives the comparative loss of cooking by coal and by gas; the former being taken at 22s. per ton, and the latter at 4s. 5d. per 1000 cubic feet.

## GAS.

| Joint.        | Weight. |     | Time. |      | When Cooked. |     | Dripping. |     | Loss. |     | Gas used.<br>Cubic Feet. | Cost of Gas at<br>4s. 5d. per 1000<br>cubic feet.<br>d. |
|---------------|---------|-----|-------|------|--------------|-----|-----------|-----|-------|-----|--------------------------|---------------------------------------------------------|
|               | lbs.    | oz. | hrs.  | min. | lbs.         | oz. | lbs.      | oz. | lbs.  | oz. |                          |                                                         |
| Leg of Mutton | 8       | 1½  | 2     | 20   | 7            | 5   | ..        | 5   | ..    | 7½  | 41                       | 2.17                                                    |
| Rib of Beef   | 10      | 14  | 2     | 37   | 9            | 10½ | ..        | 5½  | ..    | 14  | 46                       | 2.43                                                    |
| Leg of Mutton | 9       | 7   | 2     | 30   | 8            | 6   | ..        | 7½  | ..    | 9½  | 42                       | 2.22                                                    |
| Rib of Beef   | 11      | 0   | 2     | 45   | 9            | 13  | ..        | 4½  | ..    | 14½ | 48                       | 2.54                                                    |
|               | 39      | 6½  | ..    | ..   | 35           | 2½  | 1         | 6½  | 2     | 13½ | 177                      | 9.36                                                    |

## COAL.

| Joint.        | Weight. |     | Time. |      | When Cooked. |     | Dripping. |     | Loss. |     | Coal used.<br>lbs. | Cost at<br>22s. per<br>ton.<br>d. | Wood. | Total<br>Cost. |
|---------------|---------|-----|-------|------|--------------|-----|-----------|-----|-------|-----|--------------------|-----------------------------------|-------|----------------|
|               | lbs.    | oz. | hrs.  | min. | lbs.         | oz. | lbs.      | oz. | lbs.  | oz. |                    |                                   |       |                |
| Leg of Mutton | 8       | 1½  | 2     | 50   | 7            | 0½  | ..        | 8   | ..    | 7½  | 28½                | 3.36                              | 0.50  | 3.86           |
| Rib of Beef   | 10      | 14  | 2     | 45   | 9            | 10½ | ..        | 5   | ..    | 14½ | 29                 | 3.42                              | 0.50  | 3.92           |
| Leg of Mutton | 9       | 12  | 2     | 30   | 8            | ..  | ..        | 16  | 1     | 2   | 28                 | 3.30                              | 0.50  | 3.80           |
| Rib of Beef   | 13      | 2   | 2     | 50   | 11           | 13  | ..        | 6   | ..    | 15  | 30                 | 3.53                              | 0.50  | 4.03           |
|               | 41      | 13½ | ..    | ..   | 36           | 8½  | 1         | 13  | 3     | 7   | 115½               | 13.61                             | 2.00  | 15.61          |

From the above it will be seen that the advantage is decidedly on the side of gas, as far as actual cost is concerned, with the additional one, that immediately the cooking is over the gas is turned off, and there is no further consumption in waste, as in the case of cooking with a coal fire.

In cooking meat by gas it is roasted, not baked, as in the common cooking oven: the difference being in baking, that the meat is excluded from the air, whilst in the former it is exposed to a continual current, which gives that peculiar flavour to roast meat which baked meat has not.

NOTE.—For cost of gas per hour at different rates per 1000 cubic feet, in fractions of a penny, see page 128.

## GAS COOKING APPARATUS,

For Hospitals, Clubs, Warehouses, etc., designed and arranged to suit special requirements.

GEORGE BOWER, ST. NEOTS, HUNTINGDONSHIRE.



[8]

# SUNDRY TOOLS AND IMPLEMENTS

MANUFACTURED AND SUPPLIED BY

## GEORGE BOWER,

*Gas and Water Engineer and Contractor, St. Neots, Hunts.*

Illustrations of the Tools and Implements necessary in the Retort House of Gas Works will be found on page 29, and sundry Gas Fitters' Tools on page 113.

### PORTABLE FORGES.

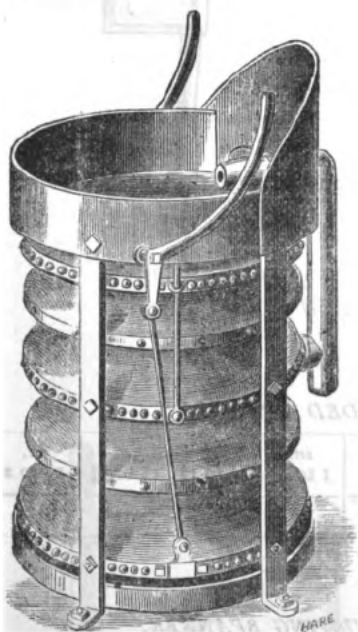

- |                                                                                                             |         |
|-------------------------------------------------------------------------------------------------------------|---------|
| No. 1. Single Blast, 20 in. diameter, 28 in. high, 18 in. bellows .                                         | £ s. d. |
| „ 2. Double Blast, 24 „ 34 „ 22 „ .                                                                         |         |
| Portable Forge, with Bellows boxed in with sheet iron as a protection from damage by fire or other causes . |         |
| No. 3. Double Blast, 22 in. diameter, 32 in. high (specially recommended) .                                 |         |

### SMITHS' BELLOWS.

| Sizes .  | in.<br>20 | in.<br>22 | in.<br>24 | in.<br>26 | in.<br>28 | in.<br>30 | in.<br>32 | in.<br>34 | in.<br>36 | in.<br>38 | in.<br>40 |
|----------|-----------|-----------|-----------|-----------|-----------|-----------|-----------|-----------|-----------|-----------|-----------|
| Prices . |           |           |           |           |           |           |           |           |           |           |           |

### WATER TUYERE.

| Sizes .  | in.<br>12 | in.<br>13 | in.<br>14 | in.<br>15 | in.<br>16 |
|----------|-----------|-----------|-----------|-----------|-----------|
| Prices . |           |           |           |           |           |

CAST-IRON HEARTH FRAMES, WITH SLAKE TROUGHS, TUYERE PLATES AND HOODS, COMPLETE.

CISTERNS FOR WATER-TUYERES. SMITHS' TOOLS OF EVERY DESCRIPTION.

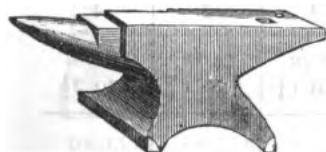

ANVIL.

- |                                |   |            |
|--------------------------------|---|------------|
| BEST WARRANTED ANVILS .        | . | per cwt. £ |
| BEST ANVILS .                  | . | ”          |
| „ with two beaks or side horns | . | ”          |



ENGINEERS' HAMMERS, 1½ lbs. each, and upwards per lb. £

„ cast steel „ ”

BOILER MAKERS' HAMMERS, iron and steel „

„ „ cast steel . „



RIVETING HAMMERS (gas-holder) . „

HAMMERS.

SLEDGE HAMMERS, 5 to 9 lbs. . „

„ 10 to 12 lbs. . „

„ 12 lbs. and upwards . „

CAST-STEEL CHISELS, CROSS-CUTS POINTS, ETC. . . . . per lb.

IRON „ CAULKING TOOLS . . . . . ”

IRON „ . . . . . ”

GEORGE BOWER, ST. NEOTS, HUNTINGDONSHIRE.

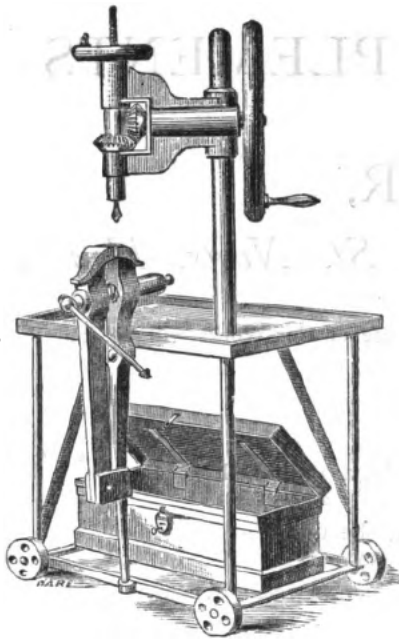

DRILLING MACHINE, BENCH AND VICE, COMPLETE.

PRICE . . . £

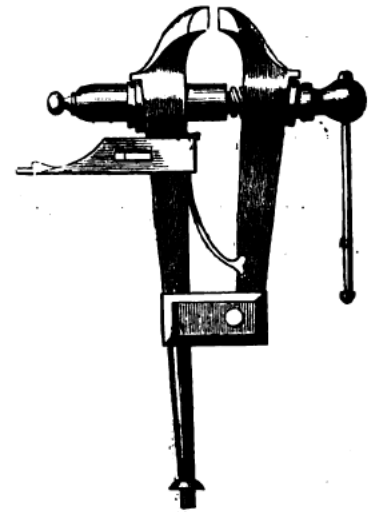

Warranted bright Vices . . . . . per lb.  
 " black " . . . . . "  
 Parallel Vices, with steel jaws . . . . . "  
 Adjustable Vices arranged so as to grasp firmly tapered articles . . . . . "

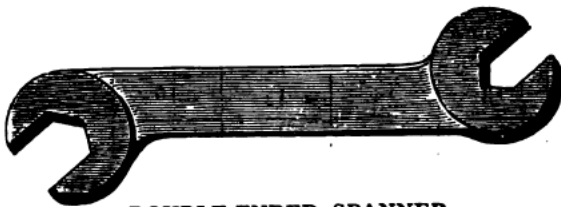

DOUBLE-ENDED SPANNER.

DOUBLE-ENDED SPANNER.

|       |                                    |                        |                         |                                      |                                      |                         |
|-------|------------------------------------|------------------------|-------------------------|--------------------------------------|--------------------------------------|-------------------------|
| Span  | $\frac{1}{2}$ to $\frac{3}{4}$ in. | $\frac{3}{4}$ to 1 in. | 1 to $1\frac{1}{4}$ in. | $1\frac{1}{4}$ to $1\frac{1}{2}$ in. | $1\frac{1}{2}$ to $1\frac{3}{4}$ in. | $1\frac{3}{4}$ to 2 in. |
| Price |                                    |                        |                         |                                      |                                      |                         |

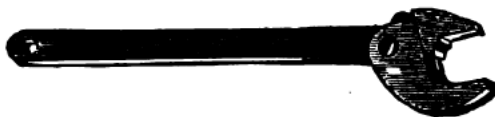

SELF-ADJUSTING SPANNER.

SELF-ADJUSTING SPANNER.

|        |                    |                                 |                                 |                                 |
|--------|--------------------|---------------------------------|---------------------------------|---------------------------------|
| No.    | 1                  | 2                               | 3                               | 4                               |
| Length | 8 in.              | 10 in.                          | 14 in.                          | 18 in.                          |
| Span   | $\frac{1}{2}$ to 1 | $\frac{3}{8}$ to $1\frac{1}{4}$ | $\frac{5}{8}$ to $1\frac{3}{4}$ | $\frac{7}{8}$ to $2\frac{1}{2}$ |
| Price  |                    |                                 |                                 |                                 |

ADJUSTABLE SCREW KEYS OF THE BEST CONSTRUCTION.

|         |       |       |        |        |        |        |        |        |        |
|---------|-------|-------|--------|--------|--------|--------|--------|--------|--------|
| Lengths | 6 in. | 8 in. | 10 in. | 12 in. | 14 in. | 16 in. | 18 in. | 20 in. | 22 in. |
| Prices  |       |       |        |        |        |        |        |        |        |



Stone Picks . . . per cwt.  
 Mattocks . . . . . "

FILES AND RASPS OF EXCELLENT QUALITY,  
 At the "Sheffield List" prices.

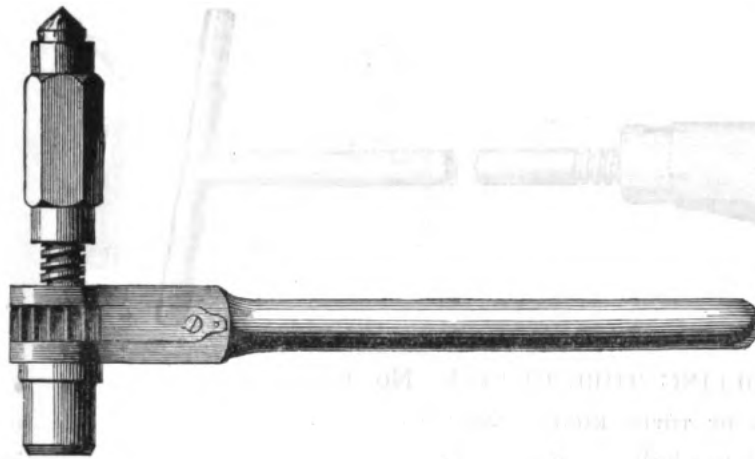

RATCHET BRACES.

|            |           |           |           |           |
|------------|-----------|-----------|-----------|-----------|
| Length     | in.<br>12 | in.<br>14 | in.<br>16 | in.<br>18 |
| Price each |           |           |           |           |

  

|            |           |           |           |
|------------|-----------|-----------|-----------|
| Length     | in.<br>20 | in.<br>22 | in.<br>24 |
| Price each |           |           |           |

BENCH DRILLING MACHINE.

Price, without Drills or Ratchet,

Height . . . . . 16 inches.  
 Length of Arm . . . . . 14 "  
 Weight, about 32 lbs.

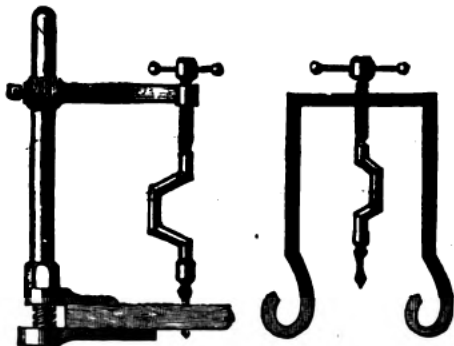
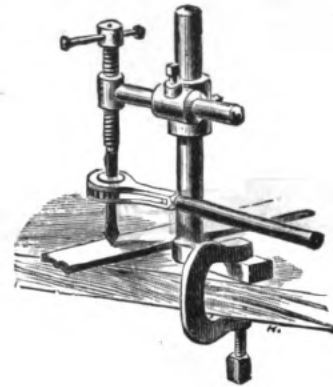

DRILLING PILLAR. CRAMP AND BRACE.

DRILLING PILLAR, BRACE, etc., complete, each £  
 Portable ditto . . . . . "

CRAMP and BRACE, complete, for drilling  
 mains, etc. . . . . "

IMPROVED TUBE VICES.

- No. 1. To hold any pipe from  $\frac{1}{8}$  in. to 2 in. . £
- " 2. Small size, for  $\frac{1}{8}$ -in. to  $\frac{3}{4}$ -in. tube .
- " 2. Large size, for  $\frac{1}{4}$ -in. to 2-in. tube .

Strongly made, to attach to a bench.

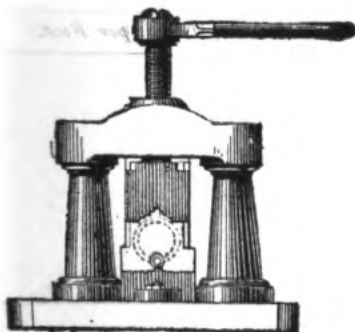

No. 1.



No. 2.



PATENT ROLLING TUBE CUTTER, No. 1.

INSIDE DIAMETER OF TUBES EACH NUMBER WILL CUT.

|             |                              |   |   |         |
|-------------|------------------------------|---|---|---------|
| To cut from | $\frac{1}{4}$ inch to 1 inch | . | . | price £ |
| "           | 1 $\frac{1}{2}$ " 2 "        | . | . | "       |
| "           | 2 " 3 "                      | . | . | "       |



PATENT ROLLING TUBE CUTTER, No. 2.

|                        |   |                 |       |
|------------------------|---|-----------------|-------|
| To cut to 1 inch, each | , | extra cutter at | each. |
| " 2 " "                |   | "               | "     |
| " 4 " "                |   | "               | "     |

TUBE PLIERS, 2 HOLES.

Length 7, 8, 9, 10, 11, 12, 14, 15 inches  
Price

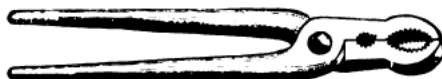

BRIGHT BURNER PLIERS.

Length . . . 6 inches, . . . 7 inches.  
Price . . . . .



WESTON'S PATENT DIFFERENTIAL PULLEY BLOCKS.

Ordinary pattern, requiring about four times the height of lift in chain. Worked by pulling at the chains.



| Tested to | Prices. |    |    | Bright B. B. Chain, Tested, per Foot. |
|-----------|---------|----|----|---------------------------------------|
|           | £       | s. | d. |                                       |
| cwt.      |         |    |    |                                       |
| 5         |         |    |    |                                       |
| 10        |         |    |    |                                       |
| 12        |         |    |    |                                       |
| 20        |         |    |    |                                       |
| 30        |         |    |    |                                       |
| 40        |         |    |    |                                       |
| 60        |         |    |    |                                       |
| 80        |         |    |    |                                       |

PULLEY BLOCKS.

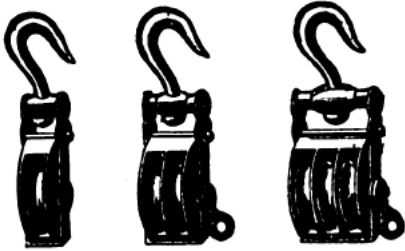

PULLEY BLOCKS.

| Diameter of Sheaves. | inches.<br>4 | inches.<br>5 | inches.<br>6 | inches.<br>7 | inches.<br>8 |
|----------------------|--------------|--------------|--------------|--------------|--------------|
| Price, with 1 Sheave |              |              |              |              |              |
| " 2 "                |              |              |              |              |              |
| " 3 "                |              |              |              |              |              |
| " 4 "                |              |              |              |              |              |

DOUBLE PURCHASE HOISTING CRAB,  
TO LIFT WITH TWO AND THREE SHEAVE PULLEY BLOCKS.

|               | 2 tons. | 3 tons. | 4 tons. | 6 tons. | 8 tons. | 10 tons. | 12 tons. | 16 tons. |
|---------------|---------|---------|---------|---------|---------|----------|----------|----------|
| With Brake    | £ s.    | £ s.    | £ s.    | £ s.    | £ s.    | £ s.     | £ s.     | £ s.     |
| Without Brake |         |         |         |         |         |          |          |          |

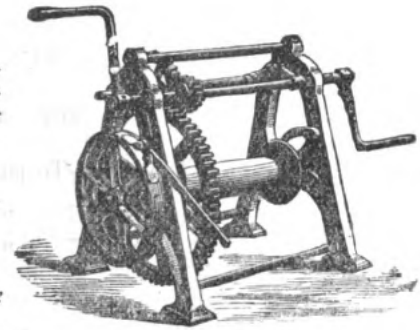

SINGLE PURCHASE CRABS,

With or without brake, to lift with 2 and 3 sheaves.

Pulley Blocks, from 1 up to 6 tons. For prices and particulars, see COMPANION.

HYDRAULIC JACKS.

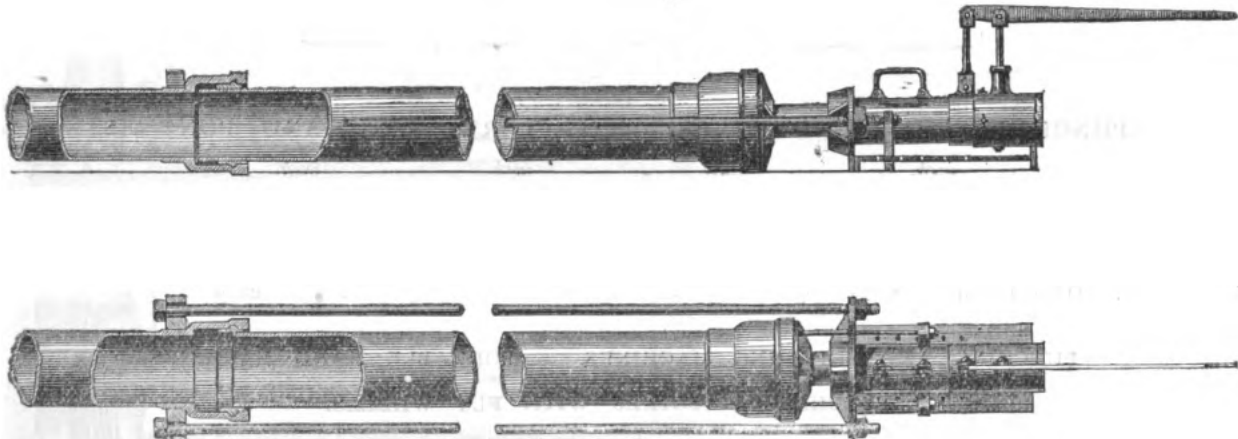

PLAN and ELEVATION OF HYDRAULIC JACK, as used in making joints with Robbin's Patent Pipes. This Jack is also applicable to pipes having turned and bored joints.

PATENT HYDRAULIC JACK.

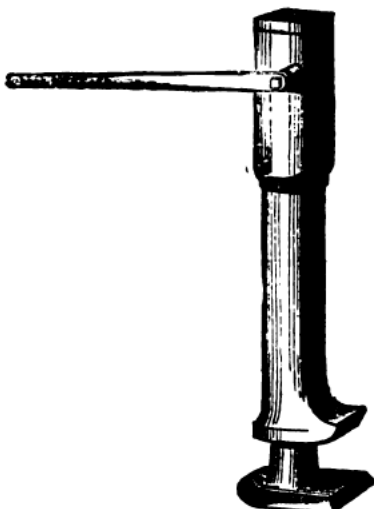

HYDRAULIC JACK.

| To Lift. | Height. | Lift.  | Approximate Weight. | Price |
|----------|---------|--------|---------------------|-------|
| 4 tons   | 23 in.  | 10 in. | 57 lbs.             | £     |
| 6 "      | 24 "    | 10 "   | 68 "                |       |
| 8 "      | 26 "    | 11 "   | 76 "                |       |
| 10 "     | 27 "    | 12 "   | 86 "                |       |
| 12 "     | 27 "    | 12 "   | 96 "                |       |
| 15 "     | 28 "    | 12 "   | 104 "               |       |
| 20 "     | 28 "    | 12 "   | 132 "               |       |

Screw Jacks and Bottle Jacks of every description.

PUNCH WITH BED, & PUNCHES FOR

|       |       |       |       |       |
|-------|-------|-------|-------|-------|
| ¼ in. | ⅜ in. | ½ in. | Price | each. |
|-------|-------|-------|-------|-------|

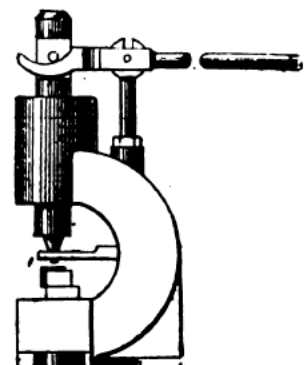

PUNCH.

## PATENT HYDRAULIC PUNCH.

MOUNTED ON LEGS WHICH CAN BE DETACHED.

|                                                                    |                |          |
|--------------------------------------------------------------------|----------------|----------|
| No. 1.—To punch $\frac{3}{4}$ in. hole in $\frac{1}{2}$ in. plate. | Weight 64 lbs. | Price, £ |
| No. 2.— " 1in. " $\frac{3}{4}$ in. " " 120 " "                     |                |          |

## PUNCHING BEAR OF CAST STEEL.

SIZES AND PRICES, INCLUDING ONE PUNCH AND DIE.

|                                                                   |                               |           |
|-------------------------------------------------------------------|-------------------------------|-----------|
| No. 1.—To punch $\frac{1}{4}$ in. hole in $\frac{1}{8}$ in. iron. | Weight 23lbs.                 | Price £   |
| No. 2.— " $\frac{1}{8}$ in. " $\frac{1}{8}$ in. " "               | 37lbs.                        |           |
| No. 3.— " $\frac{1}{8}$ in. " $\frac{3}{8}$ in. " "               | 60lbs.                        |           |
|                                                                   | If with ratchet lever,        | extra.    |
|                                                                   | " plain "                     | " "       |
|                                                                   | Extra Punches and Dies, round | per pair. |

## PUNCHING BEAR AND LEVER, WITH THREE BEDS AND PUNCHES.

|                                     | <i>inch.</i><br>$\frac{3}{8}$ | <i>inch.</i><br>$\frac{1}{2}$ | <i>inch.</i><br>$\frac{5}{8}$ | <i>inch.</i><br>$\frac{3}{4}$ |             |
|-------------------------------------|-------------------------------|-------------------------------|-------------------------------|-------------------------------|-------------|
| Price . . . . .                     |                               |                               |                               |                               | each.       |
| With ratchet lever . . . . .        |                               |                               |                               |                               | each extra. |
| Hand cramps or screw dogs . . . . . |                               |                               |                               |                               | each.       |

## PUNCHING AND SHEARING MACHINES. PORTABLE HAND MACHINES.

## PUNCHING MACHINES WITH FLY WHEELS.

## GRINDSTONES AND TROUGHS, COMPLETE.

| Diameter of Stones . . . . . | <i>inches.</i><br>12 | <i>inches.</i><br>15 | <i>inches.</i><br>18 | <i>inches.</i><br>24 | <i>inches.</i><br>36 | <i>inches.</i><br>48 |
|------------------------------|----------------------|----------------------|----------------------|----------------------|----------------------|----------------------|
| Prices . . . . .             | £ s. d.              | £ s. d.              | £ s. d.              | £ s. d.              | £ s. d.              | £ s. d.              |

## CIRCULAR SAW BENCHES.

Fixed on iron framing with plain metal top, fitted with parallel guard, and complete with fast and loose driving pulleys.

|                                                        |   |    |    |
|--------------------------------------------------------|---|----|----|
| Fitted with 24-inch saw . . . . .                      | £ | s. | d. |
| Large size, with self-acting feed motion, etc. . . . . |   |    |    |

GEORGE BOWER, ST. NEOTS, HUNTINGDONSHIRE.

COMPLETE IRON BED LATHE,

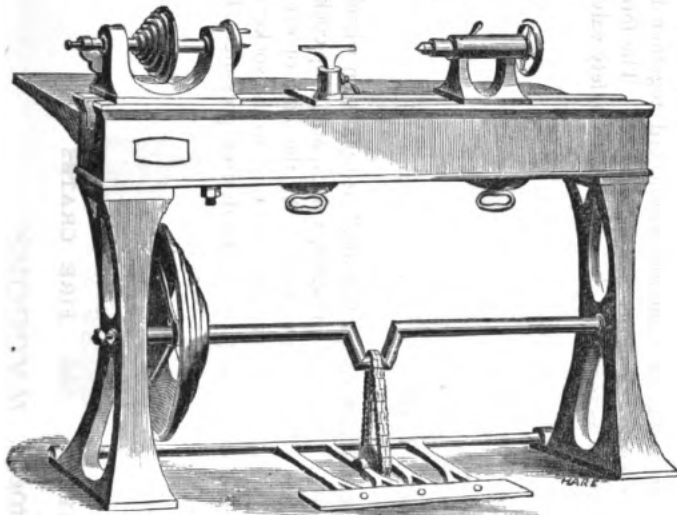

With steel collar, head stocks, and plain moving centre, rest, and tee, with chucks and centres for iron and wood turning; crank and treadle, or over head motion for power.

| Height to centre. | Length of iron bed. | Single Collars. | Double Collars. | Slide Rest extra. |
|-------------------|---------------------|-----------------|-----------------|-------------------|
| inches.           | ft. in.             | £ s. d.         | £ s. d.         | £ s. d.           |
| 3½                | 2 6                 |                 |                 |                   |
| 4                 | 3 0                 |                 |                 |                   |
| 5                 | 4 0                 |                 |                 |                   |
| 6                 | 5 0                 |                 |                 |                   |
| 7                 | 7 0                 |                 |                 |                   |

COMPLETE IRON BED LATHE,

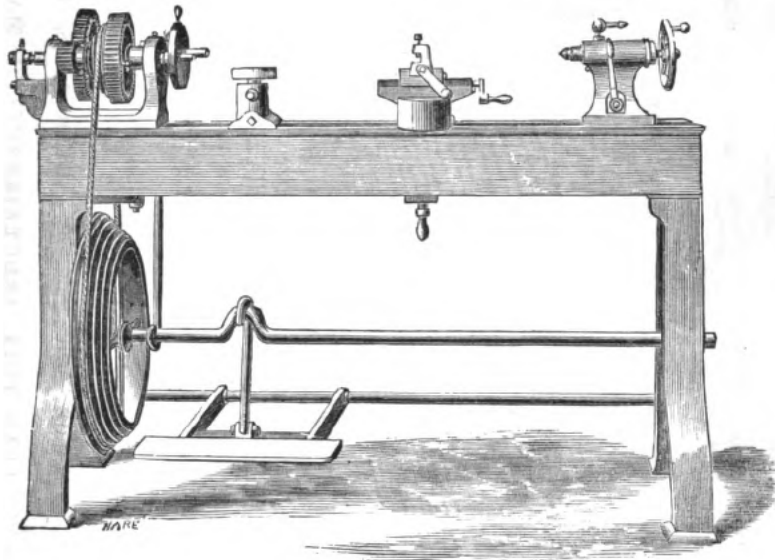

With steel collar, head stocks, best moving wheel, centre hand rest and tee, face plates and chucks, with crank and anti-friction treadle, and turned fly wheel.

|                                                 | in. | in. | in. | in. | in. |
|-------------------------------------------------|-----|-----|-----|-----|-----|
| Height to centres .                             | 4   | 5   | 6   | 7   | 8   |
| Length of bed .                                 | 3   | 4   | 5   | 6   | 7   |
| Single collar head-stock . . .                  | £   | £   | £   | £   | £   |
| Double collar ditto.                            |     |     |     |     |     |
| Double collar head-stock, with back gear . . .  |     |     |     |     |     |
| Price of slide rest extra . . .                 |     |     |     |     |     |
| With guide screw and set of change wheels . . . |     |     |     |     |     |

SELF-ACTING SLIDING AND SCREW CUTTING LATHES.

AMERICAN SELF-ADJUSTING SCROLL CHUCKS,

For adjusting work accurately and quickly, either by the use of levers or keys. Made to hold any article not larger than the diameter of the Chuck.

EMERY WHEELS OF VARIOUS QUALITIES.

WARRANTED STOCKS, DIES, AND TAPS, FOR ENGINEERS.

WHITWORTH'S STANDARD THREAD AND GAUGE.

For Description and Prices, see "COMPANION."

## APPARATUS FOR TESTING CAST-IRON MAIN PIPES BY HYDRAULIC PRESSURE.

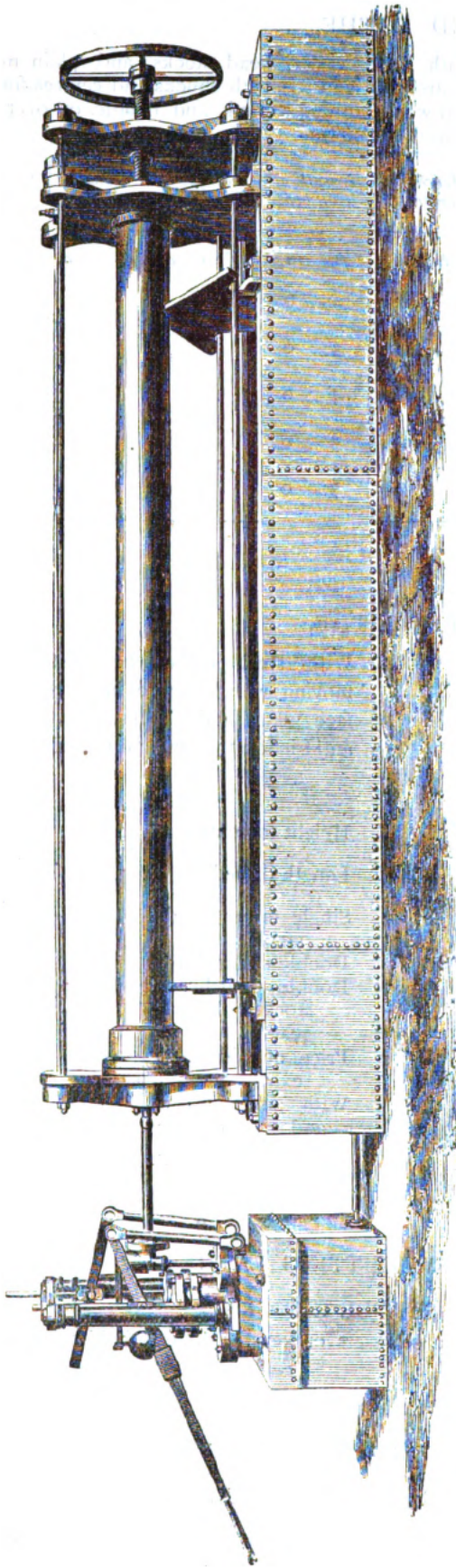

This Apparatus consists of a wrought-iron cistern or trough, on which are fixed or bolted two cast-iron heads or standards, connected together by wrought-iron tie-rods; there is a sliding standard, which is forced up against the end of the tubes to be tested by means of a hand wheel. The force pump has two barrels, one of which is considerably larger than the other, in order to vary the speed and power as required; it is fitted with safety valve, gauge, etc., complete, and the whole is constructed in a workmanlike and substantial manner.

## AIR PUMP, FOR TESTING JOINTS OF MAINS WHEN LAID.

This convenient instrument is very useful for detecting leakages in the joints of pipes as laid. The pump is fixed upon a small bed-plate, on wheels, and is fitted complete with crank, fly-wheel and handle, pressure-gauge to indicate any pressure up to 24 in. head of water, valves, and stop-cocks. Stop ends, clips, bolts, and rubber joint rings, are also supplied for any size of socket, with nozzle-piece for attaching the hose. At the end of every day's work of mainlaying, and before filling in over the joints, a stop-end is applied and securely jointed, with an india-rubber joint-ring, to the socket of the last pipe laid, the hose from the pump is attached, when, by working the pump, air is speedily compressed in the pipes to the desired pressure. By the application of a little soap-water to the joints under test, the slightest leakage will readily be detected.

SPIRIT LEVELS.

PLUMB BOBS.

SHEER LEGS, FOR MAINLAYING.

FIRE CRATES

LEAD POTS AND LADLES.

MAINLAYERS' TOOLS.



IMPROVED PATENT WEIGH-BRIDGE FOR ROAD WAGGONS.

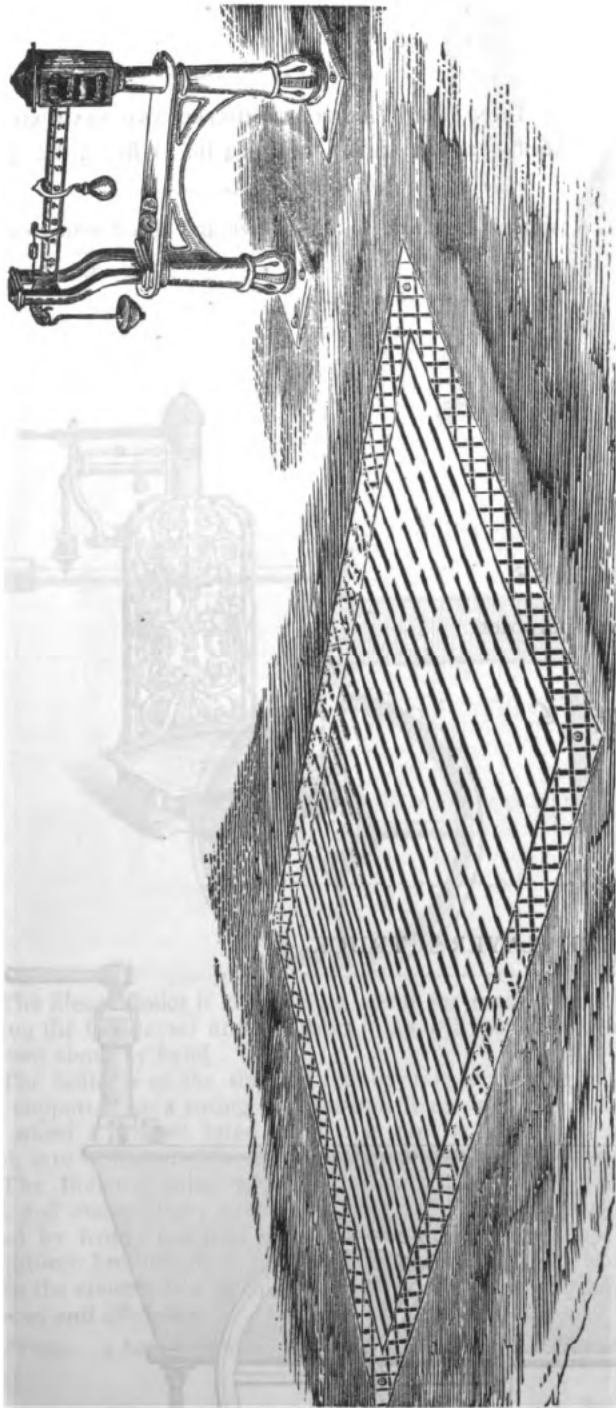

**No. 1.**—This machine is highly finished and accurately fitted, with due regard to strength and durability. It may be fixed by any ordinary mason. To prevent error or fraud in weighing two-wheeled carts, it is recommended that weighing machines should be capable of weighing horse and cart together.

PATENT WEIGH-BRIDGE FOR WAGGONS.

| To weigh. | Size of Platform.         | £ | s. | d. |
|-----------|---------------------------|---|----|----|
| 5 Tons    | 8 feet by 6 feet 3 inches | . | .  | .  |
| 8 "       | 10 " 6 " 6 "              | . | .  | .  |
| 10 "      | 11 " 7 "                  | . | .  | .  |
| 12 "      | 12 " 7 "                  | . | .  | .  |
| 12 "      | 12 " 8 "                  | . | .  | .  |
| 15 "      | 14 " 8 "                  | . | .  | .  |

WEIGH-BRIDGE FOR CARTS.

| To weigh. | Size of Platform.                  | £ | s. | d. |
|-----------|------------------------------------|---|----|----|
| 3 Tons    | 4 feet 6 inches by 5 feet 6 inches | . | .  | .  |
| 4 "       | 4 " 6 " 6 " 0 "                    | . | .  | .  |
| 4 "       | 4 " 6 " 6 " 6 "                    | . | .  | .  |
| 4 "       | 6 " 6 " 6 " 0 "                    | . | .  | .  |
| 5 "       | 6 " 6 " 6 " 6 "                    | . | .  | .  |

Either of the above machines may be had self-contained if required. The indicating beams may be placed inside the office, to be entirely under the control of the attendant; thus avoiding the risk of damage or being tampered with.

Fitted with Relieving Apparatus at extra cost.

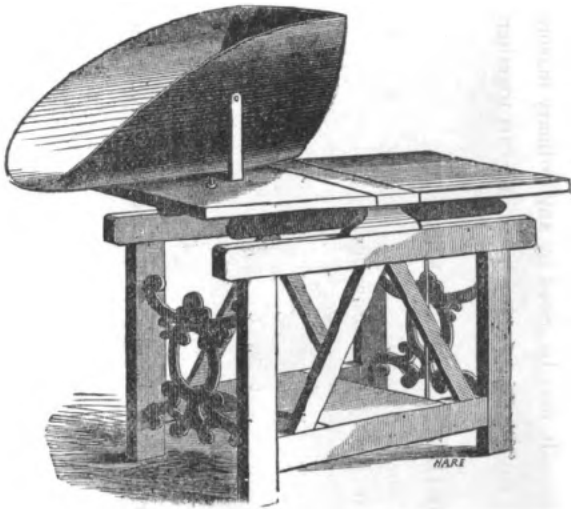

WEIGHING MACHINE, FOR COAL AND COKE.

COAL WEIGHING MACHINE.

This machine is fitted with strong iron scoop to tilt.

|                |   |   |   |
|----------------|---|---|---|
| To weigh 1 cwt | . | . | £ |
| " 2 "          | . | . |   |
| " 3 "          | . | . |   |

IRON BAR WEIGHTS, ADJUSTED AND STAMPED.

56 lb., 28 lb., 14 lb., 7 lb., 4 lb., 1 lb., ½ lb., ¼ lb.

A similar Machine to the above, but fitted with steel-yard

|                |   |   |   |
|----------------|---|---|---|
| To weigh 1 cwt | . | . | £ |
| " 1½ "         | . | . |   |
| " 2 "          | . | . |   |

LEVER PLATFORM WEIGHING MACHINE.

Constructed for weighing sacks, and for general purposes.

| TO WEIGH | SIZE OF PLATFORM.           |   |
|----------|-----------------------------|---|
| 4 cwt.   | 1 ft. 11 in. by 1 ft. 7 in. | £ |
| 5 "      | 2 ft. by 1 ft. 11 in.       |   |



MAIN AND SERVICE LAYER'S TRUCK.

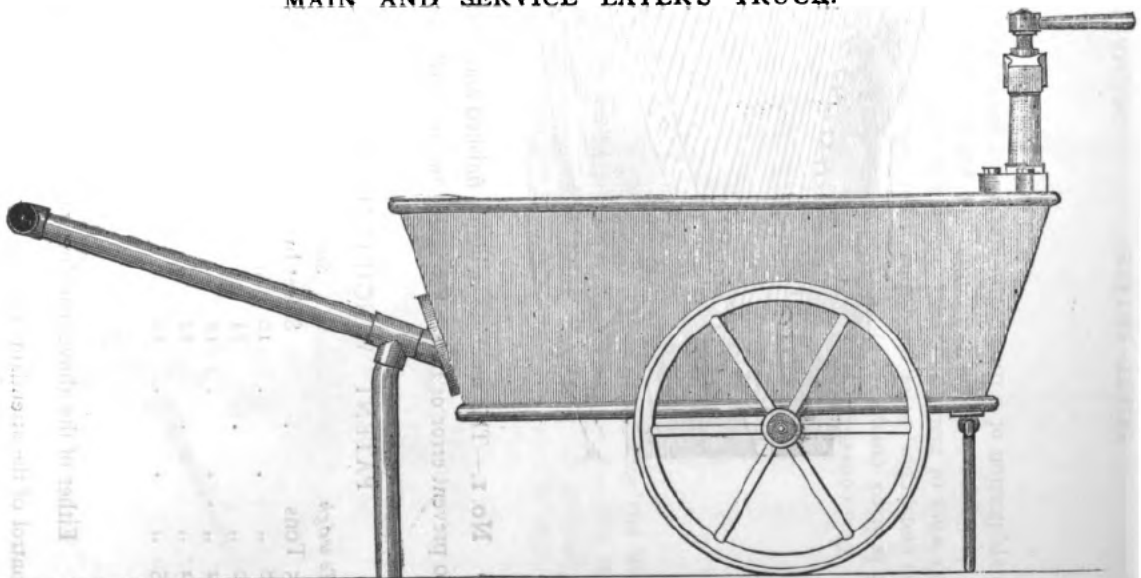

The truck is fitted complete, with cover and lock, and provision at end for bolting on pipe vice, as shown.

GEORGE BOWER, ST. NEOTS, HUNTINGDONSHIRE.

PORTABLE STEAM BOILERS.

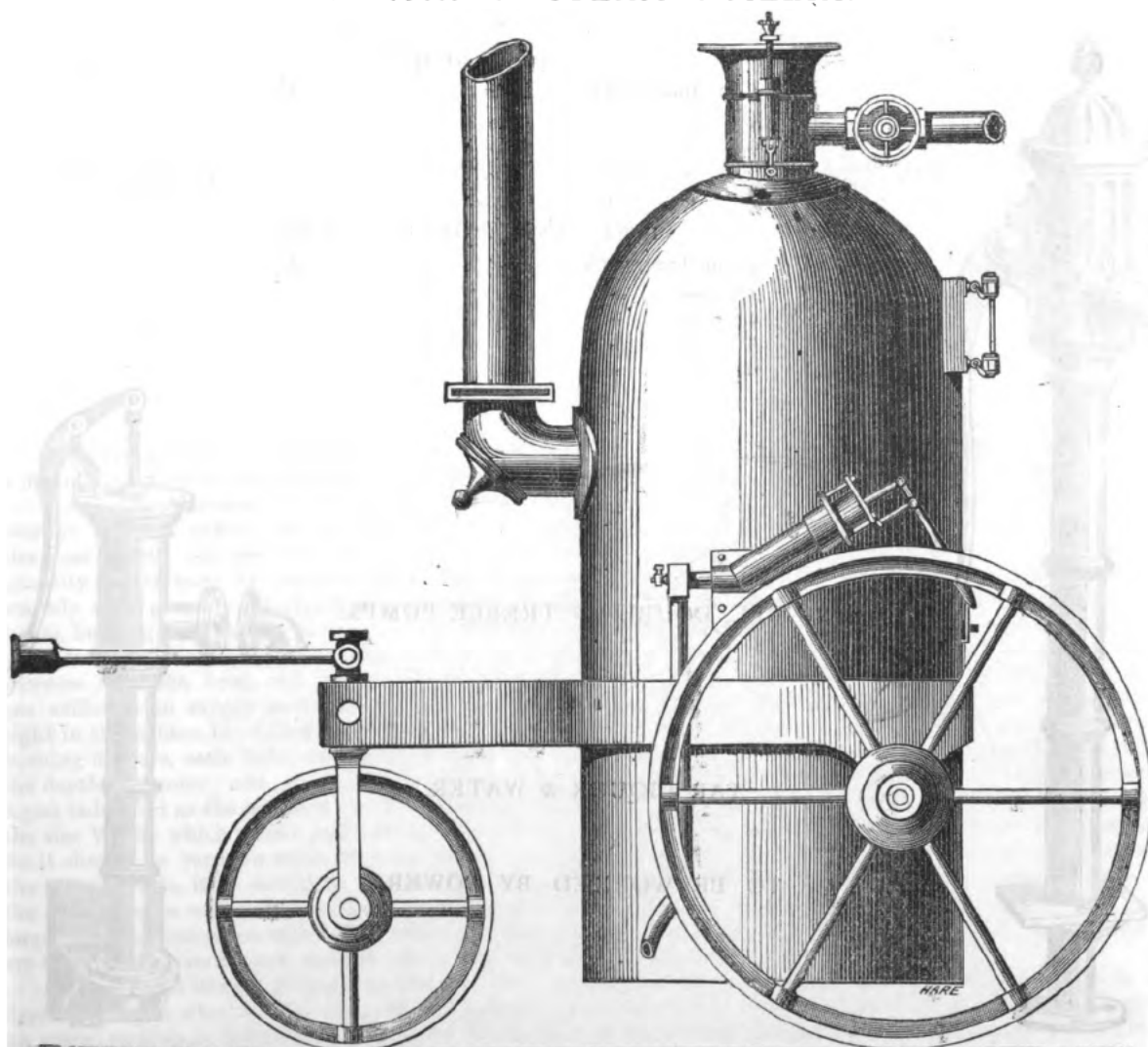

The Steam Boiler is exceedingly useful for many purposes on a gas-works, especially for blowing through and cleaning the Condenser and Scrubber. As will be seen from the engraving, it is so arranged as to enable it to be drawn about by hand.

The Boiler is of the simplest construction, consisting of a vertical cylindrical case, with an internal fire-box and grate, supported on a strong wrought-iron frame, and three cast-iron wheels, with wrought-iron spokes and axles; the front wheel is geared fitted so that it can be turned in any desired direction, and the handle is provided with a socket, into which another cross handle can be inserted.

The Boiler is fitted with a cast-iron steam dome, safety-valve with Salter's spring balance, stop valve of gun-metal, and steam pipe; two gauge cocks and glass water gauge, blow-off cock, feed pump with handle, etc., to be worked by hand; cast-iron elbow smoke pipe, with damper and cleaning plug, and one wrought-iron chimney; wrought-iron fire hole door, furnace bars and bearers complete.

In the construction of this Boiler, the principal object has been the production of a combination of compactness, lightness, and efficiency.

Prices: 1-horse Power, £                   ; 2-horse Power, £                   ; 3-horse Power, £

*Estimates and Prices given for*

STEAM BOILER FITTINGS OF ALL DESCRIPTIONS. SHAFTING AND GEARING FOR DRIVING MACHINERY;  
 IRON RETORT-HOUSES, ETC. IRON CHIMNEY STACKS FOR RETORT-HOUSES.  
 CAST AND WROUGHT-IRON GIRDERS OF ANY SIZE AND STRENGTH. CAST-IRON PILLARS.  
 CAST AND WROUGHT-IRON TANKS OF ANY SIZE AND FORM. RAIN WATER DROP PIPES AND SPOUTING.  
 CAST-IRON DRAIN GRATES AND FRAMES. CONNECTING-PIPES, BENDS, TEES, Etc.

GEORGE BOWER, ST. NEOTS, HUNTINGDONSHIRE.

PUMPS FOR TAR, LIQUOR, OR WATER.

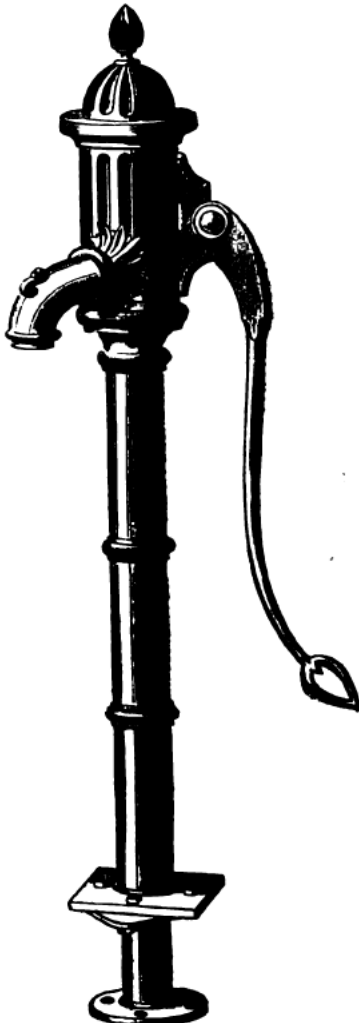

TAR PUMP.

| TAR PUMP.                  |  |   |
|----------------------------|--|---|
| 2 in. bore, each . . . . . |  | £ |
| 3 " " . . . . .            |  |   |
| 4 " " . . . . .            |  |   |
| 5 " " . . . . .            |  |   |
| 6 " " . . . . .            |  |   |

| LIFT AND FORCE PUMPS.       |  |   |
|-----------------------------|--|---|
| 2½ in. bore, each . . . . . |  | £ |
| 3 " " . . . . .             |  |   |
| 4 " " . . . . .             |  |   |
| 5 " " . . . . .             |  |   |
| 6 " " . . . . .             |  |   |

SINGLE, DOUBLE, & TREBLE PUMPS,

FOR

TAR LIQUOR & WATER,

TO BE WORKED BY POWER.

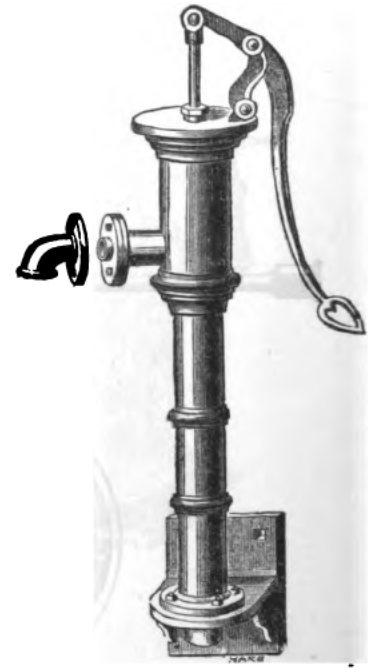

LIFT AND FORCE PUMP.

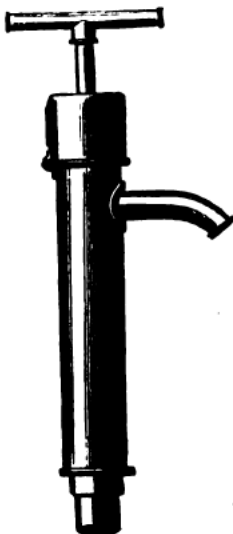

BRASS  
SYPHON  
PUMP.

SWIVEL JOINTS, FOR TAR & LIQUOR SUCTION PIPES.

Are constructed so that the suction pipe may be raised or depressed, for pumping either liquor or tar as required.

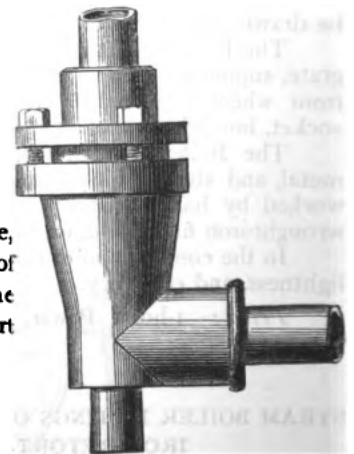

WROUGHT  
IRON  
CISTERNS,

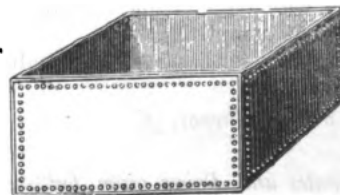

Of any size, for the supply of water to the Scrubber, Retort House, etc.

Price, per gallon capacity, £

CAST-IRON TANKS, FOR TAR AND LIQUOR, FITTED WITH SEPARATOR, AND CAST-IRON TANKS OF ALL SIZES.

[ T ]

## OBSERVATIONS

ON THE

SELECTION OF THE MANUFACTURING PLANT AND ON THE ERECTION  
OF  
GAS WORKS.

For the guidance of all, particularly of those who may reside abroad, and who may be desirous of selecting a manufacturing plant suitable for any anticipated consumption of gas, the following observations will be useful:—

1st. *For Mansions, Factories, and Private Works.*—The maximum consumption must be provided for; an average will not suffice, for although the consumption may be, say an average of 5,000 cubic feet per 24 hours the year round, yet the minimum may be 2,000, and the maximum 8,000 cubic feet, and this latter is the quantity which must be provided for. But in the first establishment of private works the actual consumption is scarcely ever properly calculated, and therefore it is strongly recommended to take the supposed maximum number of lights burning the longest time in winter, and reckon the consumption of each burner at 4 cubic feet per hour, and after doing so, then to allow a liberal margin for increase; because, as a rule, *the consumption of gas is ever on the increase for light, heat, and power.* As an example—supposing it be required to select a Gas Works to produce gas sufficient to supply 200 lights, where the hours of burning per day would vary from two in the summer to eight in the winter, the following should be the mode of arriving at the proper sized Works to order:—200 lights burning 8 hours, each light consuming 4 cubic feet per hour,  $200 \times 8 \times 4 = 6,400$  cubic feet of gas required in the depth of winter; add one-third for purposes other than light and for extensions, say 2,100 cubic feet, making 8,500 cubic feet as the quantity the Works should be capable of producing in 24 hours. No. 10a, page 84, would be the size Works which would just suffice, but No. 11a, page 85, is the one which should be adopted *to be perfectly safe*; for it should be borne in mind, that the cost of erection and of the buildings is nearly the same in the one case as in the other; while, if it should be found in the course of a short time that the Works are too small, it is possible that the existing ones will cost three times more to make them sufficiently large than would be the extra cost of having the larger size to commence with. In ordering Works, it is well always to have an extra supply of those articles which are continually wearing out, such as retorts, fire brick shields, and a few extra purifier grids.

2nd. *For Villages, Towns, and Cities.*—The consumption of gas doubles itself, as a rule, every 10 to 20 years, depending upon whether the place be a progressive or stationary one. If manufacturing it may be 10, if agricultural 20 years; so that, in determining what sized Works to erect, the present condition and future prospects of the town must be taken into consideration.

It is highly probable that gas will be used far more than it has hitherto been for domestic and manufacturing purposes, and that it may be used somewhat less for light, through the introduction of cheap mineral oils and spirits, and the possible competition of the electric light; but that there will be a generally increased consumption of gas, there cannot be a doubt. It is never worth while to hold one's competitor too cheaply, and although the electric light may be pooh-poohed in some quarters, yet it will interfere with the consumption of gas for light. The energies of Gas Work managers have been expended in an endeavour to increase the number of lights, without reference to the way in which the fittings for them have been executed; but it will be found that the best way of increasing the consumption of gas for light will be for companies themselves to undertake the fitting up of the interiors of houses, or this failing, then to have rules and regulations as to the sizes of the meters and of the pipes to be used for a given number of lights, and only to allow gas to pass from their mains to the consumer's fittings, after the whole has been properly tested by some duly authorized agent of the company.

In nineteen cases out of twenty where bad gas is complained of, it is found on examination that it is not the gas but the fittings which are at fault—meter too small, pipes too small, or bad burners. The consumer is often to blame for the perversity with which he will, on the first introduction of gas into his house, insist on only having provision made for a certain number of lights, and on this basis he screws down the fitter to the lowest sum possible for the necessary work; so that, in addition to the smallness of the meter and of the pipes, and common "cheap-jack" fittings, the work has to be scamped by the fitter to get anything out of it. By and by the consumer desires a few extra lights putting on, or it may be a cooking or a heating stove, or a bath; the result being that the meters and pipes which were originally small and attenuated are not large enough to pass the additional quantity required, and instead of there being a greater consumption of gas, it is only the existing lights which are reduced by robbing them of their full supply, and the consequence is less light to the whole, general dissatisfaction, and a letter to a newspaper complaining of the bad gas!

GEORGE BOWER, ST. NEOTS, HUNTINGDONSHIRE.

Gas Companies should get their Acts amended, to give them power to enforce regulations so far as regards meters and interior pipe fittings, based upon the consumption of gas; and the consumer should not blame the gas without first ascertaining if the conditions necessary to obtain the greatest useful effect from it have been observed by him. The main duty, however, lies with the Gas Company to teach the consumer how to effect this object, for whatever renders gas satisfactory and economical to the consumer, in the end tends to the general increase of consumption.

As a rule, the private consumption of gas is not more than one-third in a foreign town of what it is in England, per head of population.

In this country it may be put at about 2,500 cubic feet per head, while abroad it would not average more than 1,000 cubic feet; but there will be many exceptions, and it will be necessary to carefully consider them in forming an estimate of the size of Works to be erected.

The author's experience is, that in towns on the continent of from 10,000 to 50,000 inhabitants they rarely exceed for many years after the Works are erected, 1,000 cubic feet per head, unless they are manufacturing places. It is not advisable to rely upon Concessionaires' estimates of consumption, nor altogether upon the promises of intending consumers; and it should always be borne in mind that whatever may be the number of private lights promised, not more than a third of them will be burning at one time.

The greatest mistakes imaginable have been made by Concessionaires and Engineers in their estimates of private consumption, by not considering that abroad there is little of domestic life as compared with England, where a man's home is his castle, in which as a rule he seeks his happiness, rather than at the café or inn. The author knows of no more glaring instance of this miscalculation and misconception (if such mild terms are sufficiently expressive) than in the city of Moscow, where Works were erected fully three times larger than they ought to have been, and where, if a quarter of a million of pounds sterling had been expended instead of a million and a quarter upon them, there would have been some hope (even with such a bad concession) of the Works paying a moderate dividend.

No absolutely definite rule can be given for determining the capacity of Works to be erected; for very much depends, as already stated, on whether the town is stationary or progressive, agricultural or manufacturing.

The public lighting admits of easy calculation, and it may be assumed (as the result of the author's experience) that most of the lights in factories, and one-third of those in private residences, will be burning at one time in winter. Thus—take a town of 30,000 inhabitants, requiring say 500 public lights burning in winter sixteen hours; 4,500 factory and private lights, taken as 1,500 burning six hours and each light consuming four cubic feet per hour; the consumption would be  $500 \times 16 \times 4 = 32,000$ ;  $1,500 \times 6 \times 4 = 36,000$ , add for use at Works and sundries 12,000, making a total of 80,000 cubic feet as the quantity of gas the Works should be capable of producing in twenty-four hours. The gasholder room should be at least equal to two-thirds of the maximum daily production, and therefore the size Works to select would be No. 106, page 96.

In all cases where plans have to be prepared in England for Works abroad, and if there be no qualified Engineer on the spot to determine the nature of the buildings to be erected, the following information should be sent with the order for the manufacturing plant:—

1. A plan of the site to scale, showing the approaches from the main road, and the levels, taking the road, railway, or river, as datum point.
2. A pen-and-ink sketch to be given, showing the best position for the Retort House, with reference to the delivery of coals, and also the best position for the Gasholder.
3. The nature of the subsoil for a depth not exceeding that necessary for the Gasholder Tank, and stating whether water will be troublesome within that depth; and if so, give the depth.
4. The nature of the building materials, the cheapest to be used in wood, stone, brick, and concrete.
5. A plan of the town, showing the position of the public lamps, and of the site of the Gas Works, and where the principal consumption will be.
6. The number of public lights there will be, and of brackets and pillars.
7. Where practicable, the prices of building material to be given in English money and measurements.
8. The average cost of freight to the nearest seaport, and cost of the land transport; also of mechanics' and ordinary labourers' wages.
9. The nature of the town, and number of houses in it; and what proportion of them are shops, factories, public buildings, and private houses; and an estimate showing the basis of the calculation of consumption.

It may now be advisable to say a few words on the conditions to be observed in obtaining Concessions. The cardinal principle should be, to obtain the greatest consumption of gas over the smallest area possible, and to take care that the public lamps are sufficiently remunerative, for they constitute the backbone of the value of a Concession. A contract with the municipality for the public lamps is definite, and may be depended upon; while the mere right to charge a high price for gas to private consumers confers no power to make them consume the gas, and they will only do so if it be found cheaper than other methods of producing light. The general run of Concessions fixes the public lights at the lowest possible price, while the very reverse should be the case. The public lights should, almost of themselves, give sufficient profit to pay simple interest on capital, and the gas for private lighting should be sufficiently low to enable it to compete with other modes of lighting, as a consumer considers this above everything else.

Many individuals and companies think that it matters little what the public lights may be taken at, as any deficiency in this respect can be made up out of the charge for private lighting; but it is very soon discovered that the public lighting in many cases exceeds the private consumption, which can only be increased by paying no heed to the Concession price, but to what gas has to compete with; and this alone will determine, in nine towns out of ten abroad, what the private consumption will be.

In Roman Catholic countries, where there are many religious festivals and holidays, involving public illuminations, it is well to have a few retorts of iron, so that they may be put into action, just for the special occasion, as the

heats of iron retorts can be let down without much injury, which is not the case with those of clay. The great point to attend to in the design of a Gas Works is, as far as possible, so to arrange them in the first instance, that on the consumption increasing, which may necessitate the Works being enlarged, such addition may be made without having to pull down and destroy what was originally erected.

In some localities wood and peat may have to be used for making gas, and for which special apparatus is necessary to be designed. The form of the retorts should be different from those required for coal, and the hydraulic main, and the condensers and purifiers, are required to be much larger than for coal. In others it may be advisable to use petroleum either alone or reduced in illuminating power by being mixed with gas made from water or even carbonic oxide. Oil gas is exceedingly beautiful, but it is also exceedingly difficult to manage to prevent it from smoking, and, as a rule, if one looks at all the purposes to which gas is applicable, it is the author's opinion that from 14 to 20 candle power is the best to be distributed, but this must depend upon the position and kind of the town to be lighted, in reference to the material which can the better be obtained. Specifications will be found, commencing at page 99, for Oil Gas Works:

### GENERAL REMARKS.

The Buildings should be ready for the workmen when sent for, and the Gas-holder Tank kept empty until the Gas-holder is fixed.

The Scaffolding for fixing the Gas-holders must be provided for the men, and the Apparatus, tools, and men be fetched from and returned to, the nearest railway station.

Where fixing is not in the contract, or where the order is for export, instructions and working plans are sent. The Gas-holder crowns are rivetted together in pieces suitable for transport or shipment, and each piece is plainly marked or numbered, so that no mistake can occur in the fixing.

In all cases, it is recommended to have at least one extra Retort for Works up to 500 lights; and an extra bed of 3 or 5 Retorts for larger Works.

In inquiring for prices, it is necessary to give the maximum number of lights, and the longest time they will be required to burn during winter, bearing in mind the preceding observations.

Estimates and Prices given for all descriptions of gas-apparatus, gaseliers, pendants, brackets, lamps, and lamp columns, meters—both wet and dry, regulators, gas-cooking and heating stoves, stop valves, iron tanks for gas holders, iron roofs for Retort houses, etc., etc.

### EXAMPLES OF IRON PRINCIPALS FOR RETORT HOUSE ROOFING.

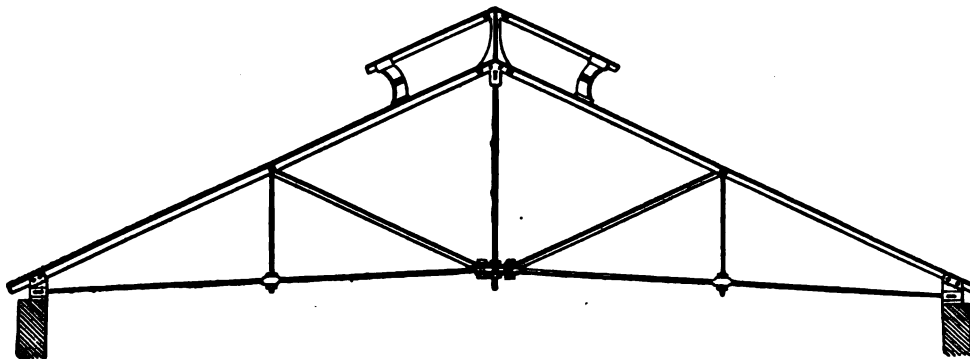

Principals for from twenty to thirty feet span, similar to above, formed of T iron main rafters, with ventilator, wrought-iron truss rods, king posts, and struts; the laths formed of angle iron rivetted on to the main and ventilator rafters, at distances suitable for Duchess slates.

Price per square yard of roof surface, with principals 5 ft. apart, £

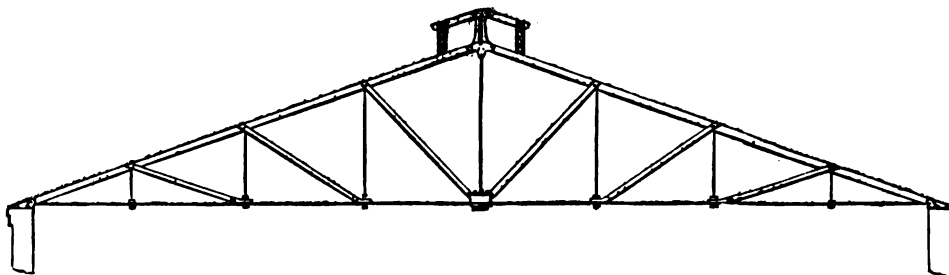

No. 10. Principals for fifty feet span, formed of wrought-iron rafters of a T section, with ventilator and wrought-iron truss rods, king posts, and struts; the laths formed of angle iron, 1 1/2 in. by 1 1/2 in. by No. 9 wire gauge rivetted on to the main and ventilator rafters, at distances suitable for Duchess slates.

Price per square yard of roof surface, with principals 5 feet apart, £

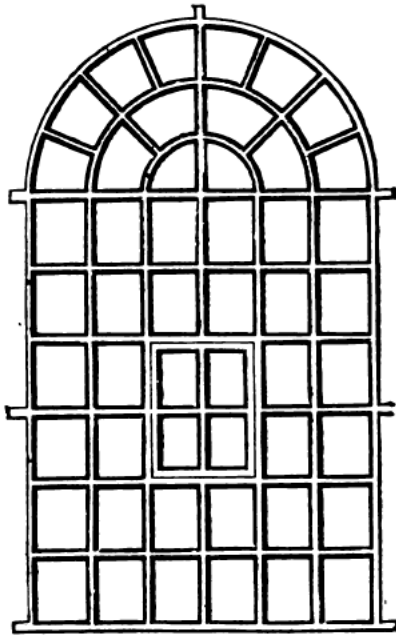

CAST-IRON WINDOW FRAMES AND FANLIGHTS.

CAST-IRON WINDOW FRAME, WITH CIRCULAR TOP.

| Height. |                 | Width. |                 | Price. |    |    |
|---------|-----------------|--------|-----------------|--------|----|----|
| ft.     | in.             | ft.    | in.             | £      | s. | d. |
| 6       | 4 $\frac{1}{2}$ | 3      | 7 $\frac{1}{2}$ |        |    |    |
| 4       | 1 $\frac{1}{2}$ | 3      | 7 $\frac{1}{2}$ |        |    |    |
| 5       | 8 $\frac{3}{8}$ | 2      | 5               |        |    |    |
| 5       | 0               | 2      | 5               |        |    |    |
| 4       | 3               | 2      | 5               |        |    |    |
| 2       | 6               | 2      | 5               |        |    |    |

RECTANGULAR WINDOW FRAMES.

| Height. |     | Width. |                  | Price. |    |    |
|---------|-----|--------|------------------|--------|----|----|
| ft.     | in. | ft.    | in.              | £      | s. | d. |
| 4       | 7   | 3      | 7 $\frac{1}{2}$  |        |    |    |
| 4       | 7   | 2      | 5 $\frac{1}{2}$  |        |    |    |
| 3       | 10  | 2      | 5 $\frac{1}{2}$  |        |    |    |
| 3       | 1   | 2      | 5 $\frac{1}{2}$  |        |    |    |
| 3       | 1   | 1      | 10 $\frac{1}{2}$ |        |    |    |

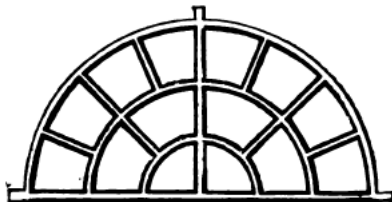
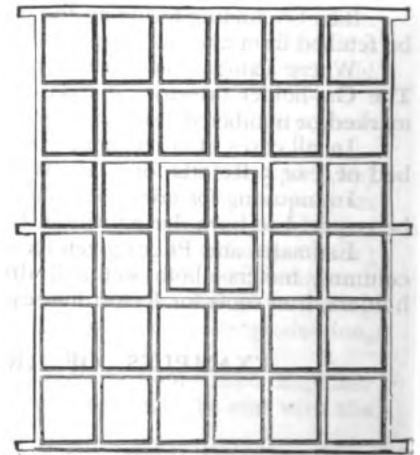

CAST-IRON FANLIGHTS.

| Width. |                 | Price. |    |    |
|--------|-----------------|--------|----|----|
| ft.    | in.             | £      | s. | d. |
| 5      | 3               |        |    |    |
| 4      | 4 $\frac{1}{2}$ |        |    |    |
| 4      | 0 $\frac{1}{2}$ |        |    |    |
| 3      | 7 $\frac{1}{2}$ |        |    |    |
| 3      | 4               |        |    |    |
| 2      | 11              |        |    |    |

IRON BUILDINGS, IRON FRAMEWORK FOR ROOFS OF ANY SPAN AND LENGTH.  
DRAWINGS, SPECIFICATIONS, AND TENDERS ON APPLICATION.

CARBURETTING GASES AND AIR.

In 1830, some excitement existed among gas companies, through the patent obtained by Michael Donovan, which seemed likely to alter materially the process of gas manufacture.

This patent was for "An improved method of lighting places with gas," and consisted in "enriching those gases which afford little light while burning, by substances which will impart to them a higher illuminating power; and may consist in bringing the gas (in preference produced by the action of steam on coke heated to redness) into contact with the liquid or vapours of the spirit of vegetable tar, coal naphtha, naphthaline or similar substances, heated or otherwise, and employing the combined mixture as the illuminating agent. This object may be effected advantageously in an apparatus attached to the burner or otherwise."

From the preceding we gather that the patentee's intention was to produce impure hydrogen gas, by which the hydro-carbon vapours would be absorbed, and thus in proportion to the quantity of these vapours in combination with any particular description of gas, so would be its degree of luminosity.

Two years afterwards, George Lowe patented the same process for enriching coal gas; and in 1847 Mansfield obtained a patent for "the manufacture from bituminous matters (by acting upon them at suitable temperatures) spirituous substances, which are so volatile, that a current of atmospheric air passed through them at ordinary temperatures will ignite and continue to burn with a luminous flame, till all or nearly all such spirituous substances are consumed."

The process described, so far as regards the gases, was during several years termed "naphthalizing," as naphtha was the principal available material employed for the purpose; but since the discovery of petroleum, and the light hydro-carbonaceous spirit derived therefrom, this, on account of its price and adaptability, has very generally been substituted for the naphtha. Hence the term has been changed into "carburetting."



[U]  
PORTABLE GAS FOR LIGHTING RAILWAY  
TRAINS, TRAM CARS,  
CARRIAGES, STEAM SHIPS, BUOYS, AND ISOLATED PLACES,

MANUFACTURED AND SUPPLIED BY

GEORGE BOWER,

*Gas and Water Engineer and Contractor, St. Neots, Hunts.*

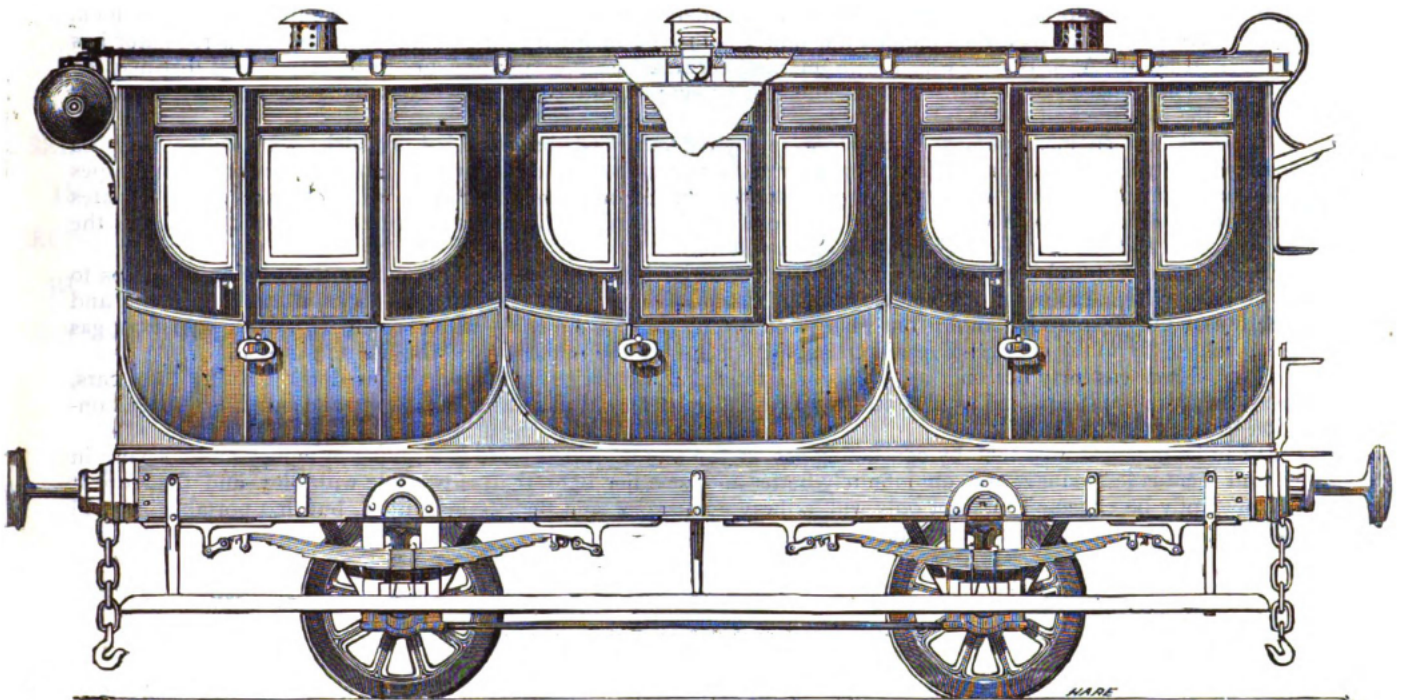

RAILWAY CARRIAGE

WITH RECEIVER FOR COMPRESSED GAS, REGULATING VALVE, AND PIPES ATTACHED.

Illuminating gas, like the air we breathe, may be compressed almost indefinitely, depending upon the power expended in the operation.

A vessel of any cubical capacity would have an internal pressure of 15 lb. to the square inch for every additional equal volume forced into it: thus a cylinder with a capacity of 10 c. f. would when sufficient gas was forced into it to indicate a pressure of 150 lbs. to the square inch, contain 100 cubic feet. A vessel whose normal capacity is 10 c. f. would, at 150 lbs. per square inch, contain sufficient gas to allow four lights to burn for from 18 to 20 hours; and it is only a question of capacity, and degree of compression, for any extra time that may be desired. If room can be found for the cylinders, the lights might burn for three or four days, but the better plan is to have them of such a size as to require refilling once a day.

In order to obtain the greatest amount of illuminating matter out of the smallest cubical space occupied, it is sometimes advisable to begin with a gas of the highest illuminating power possible. and this may be obtained from very rich cannel or shales, or from mineral or other oils, which give about three times the illuminating power of gas made from ordinary coal. The gas, is, of course, far more costly than that supplied in the general way; but the object sought to be obtained with portable gas is, to get the greatest amount of light from the least quantity consumed.

Another plan devised by the author is, to use ordinary gas, and surcharge it with carbon, either permanently or in the form of vapour, to such an extent as to bring up the illuminating power equal to gas made from oil, and for compressed gas it offers many advantages.

GEORGE BOWER, ST. NEOTS, HUNTINGDONSHIRE.

There is nothing new in portable gas. Companies were formed many years ago in London, Paris, and other large cities, and were worked profitably in some of them for some time; but they gave way one after the other, and it is doubtful if a single company now exists for the supply of portable gas for domestic lighting.

In the first edition of "THE GAS ENGINEER'S BOOK OF REFERENCE" it was there stated the conditions which railway companies would require before they adopted gas for lighting their trains; and though nearly twenty years have elapsed since that publication, nothing has happened to give reason for any material modification of that statement; on the contrary, the system then suggested has been largely followed both in Germany and elsewhere.

It may be safely affirmed that if railway trains are to be lighted with gas some advantages must be shown either on the score of economy, convenience, or safety; perhaps on all of them.

If very rich cannel or oil gas be used, it will cost from 10s. to 15s. per 1000 c. f., and as a good light will be expected, not less than  $1\frac{1}{4}$  c. f. per hour should be used in all compartments with only one light in them: at this rate the cost for a much better light is less than with petroleum, while the saving to be effected by there being no waste of oil or of wicks, and in time—by their being no lamps to trim or clean,—is very largely in favour of gas; but this cost may be materially reduced by using such gas as can be obtained at any of the stations, and having a special arrangement for surcharging it with carbon to increase its illuminating power, and this may be done to such an extent, as that one cubic foot will abundantly light the compartment of a carriage, and at a cost not exceeding one penny for from 10 to 12 hours for such light, or one half that of oil gas.

The difficulty with high-pressure gas, has been in devising an instrument for the reduction of the pressure to, and in maintaining one uniform level gauge, whether the cylinders have gas in them at 150 lbs. or 1 lb. to the square inch. The best pressure for gas of a high illuminating power is that balancing a 1-in. column of water, and a regulator has been devised by Mr. A. S. Bower, which, with unerring accuracy, enables any pressure to be maintained that may be desired. Each carriage should have its own independent supply, and the receiver containing the gas may be either placed on the top, the end, or underneath it.

Compressing engines, pumps, and storage cylinders, must be provided at such stations as may be necessary, and when the train is made up, the gas receivers attached to each carriage can be filled from stand-pipes on the platform or in any other way the most convenient, and the operation will not take many minutes for charging the receivers of a whole train. Each carriage has a regulator, and a pressure gauge, which indicates the quantity of gas and the number of hours the lights will burn.

There is a direct and important saving in first cost by having gas instead of oil, and in there being no lamps to trim, no danger from explosion or spontaneous combustion of oily-cotton waste and oil wicks in the lamp room, and not a tittle of the cleaning required; but what is of for more importance, the better and more certain light from gas will add materially to the comfort of passengers, and thus ensure the popularity of the line adopting it.

Compressed gas may not only be used for lighting railway trains, but it may be used for lighting tram cars, river and channel steamers (and with a little more difficulty ocean steamers as well), buoys, and buildings not in connection with current gas supply.

It can be demonstrated that by consuming gas in the way indicated there is a saving in money and a saving in time, and there is less danger and an infinitely better and steadier light than is possible with oil; and therefore it may confidently be expected that not only will railway companies light their trains with it, but that portable gas will be used for many other purposes as well.

*(See Note below.)*

## DESIGNS AND DESCRIPTION OF COMPRESSING ENGINES, PUMPS, AND STORAGE CYLINDERS, ON APPLICATION.

### RECEIVERS FOR HIGH PRESSURE GAS.

#### REGULATORS.

#### HIGH PRESSURE STOP VALVES, WITHOUT STUFFING BOXES.

For description of Apparatus suitable for the manufacture of Gas from Oils, Petroleum, etc., see Section A, page 15; and for Specifications and Details of Coal Gas Apparatus, see Section L, page 79.

NOTE.—The engraving is the same as that used in the first edition of the "GAS ENGINEER'S BOOK OF REFERENCE," and shows the gas receiver at the end of the carriage and at the top; but it may be placed underneath, or wherever it will be most out of the way.

GEORGE BOWER, ST. NEOTS, HUNTINGDONSHIRE.

[V]

# HEATING APPARATUS,

## FOR CHURCHES, FACTORIES, CONSERVATORIES, HOT-HOUSES, AND EVERY DESCRIPTION OF BUILDING TO WHICH ARTIFICIAL HEAT IS APPLIED.

### HOT WATER BOILERS.

SELF-CONTAINED, OR FOR SETTING BRICKWORK.

PATENT  
SELF-REGULATING BOILER  
IN STRONG WROUGHT-  
IRON CASE, REQUIRING NO  
BRICKWORK, IS EASILY  
MANAGED, AND NEEDS BUT  
LITTLE ATTENTION  
FOR FROM  
10 TO 12 HOURS.

For detailed description, see below.

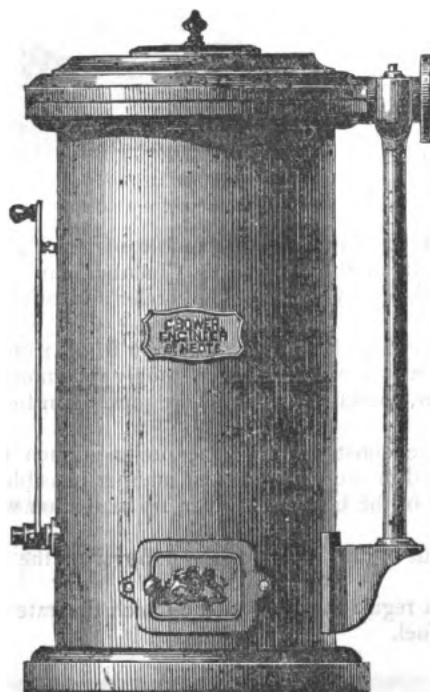

| No. of Boilers. | <i>Length of 4 in. pipe. Each boiler will heat without attention for from 10 to 12 hours.</i> | Price. |
|-----------------|-----------------------------------------------------------------------------------------------|--------|
| 1               | 250                                                                                           |        |
| 2               | 400                                                                                           |        |
| 3               | 500                                                                                           |        |
| 4               | 600                                                                                           |        |
| 5               | 900                                                                                           |        |
| 6               | 1,600                                                                                         |        |
| 7               | 2,500                                                                                         |        |
| 8               | 3,500                                                                                         |        |

This Boiler possesses the following advantages :—

It is complete within itself, requiring no brick work whatever, as is the case with ordinary boilers.

It is essentially a slow combustion boiler, the fuel used being ordinary gas coke. The heat of the water regulates the combustion of the fuel, and the mercurial valve can be so adjusted that any required degree of heat under 200° Fahr. can be given to the water, which it will maintain until the fuel is exhausted, without any attention, whatever.

The first cost is not more than wrought iron saddle boilers, with their appendages and brick work.

A considerable saving in fuel and labour is effected.

The construction of the boiler is very simple, and it is almost self-acting.

The mercurial regulating valve possesses the qualities of delicacy and certainty of action, to a degree unattainable with any other contrivance at present in use ; the water, after circulation through the boiler, passes into a hollow sphere in which is a cylinder containing mercury, to which is attached a short piece of wrought-iron tube again attached to a longer tube of india rubber enclosed by a brass spiral coil which acts as a spring, the lower end of this tube is furnished with a union and rod by means of which it is hermetically sealed, the other end of the rod is attached to a swing valve through which alone air enters the furnace. By the means of a swivel the width of the valve opening can be adjusted to the degree of combustion necessary to maintain the required temperature. The heat of the water acting upon the mercury in the cylinder and tube, the rod is moved forward, and thus by the expansion and contraction of the mercury the valve is either closed or opened. The rate of combustion is thus regulated so that uniformity in the heat of the water is ensured with the utmost exactitude, and without any attention whatever for a great number of hours.

GEORGE BOWER, ST. NEOTS, HUNTINGDONSHIRE.

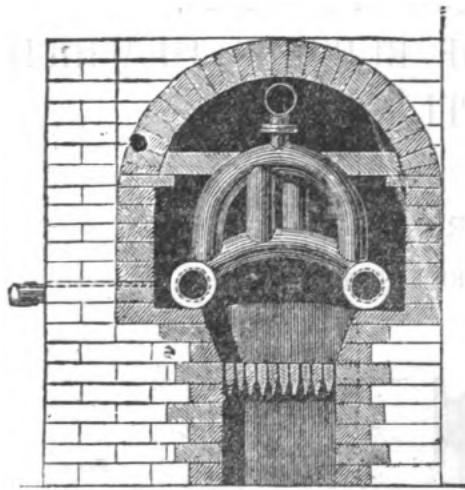
**HOT WATER BOILERS FOR SETTING IN BRICKWORK.****THE UNIT BOILER.**

TRANSVERSE SECTION.

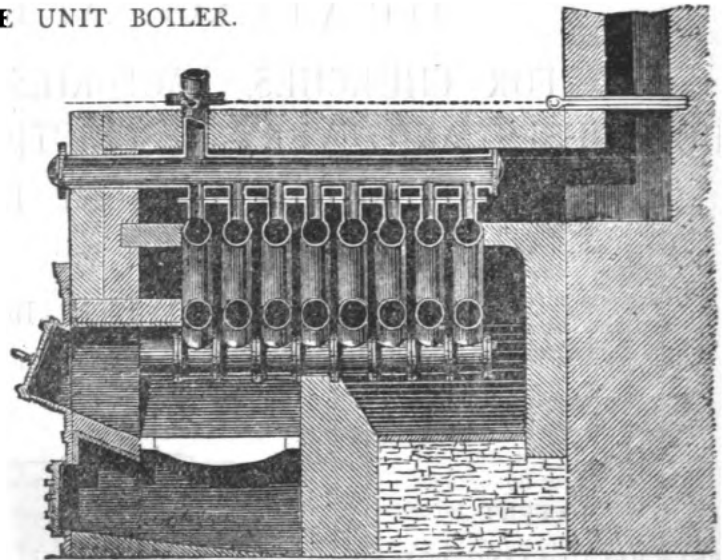

LONGITUDINAL SECTION.

The above drawings represent a Hot Water Boiler capable of heating 2,000 ft. run of 4 in. pipe; the space requisite for fixing it, supposing two walls of the Apparatus Chamber can be built against, is 4 ft. 9 in. by 9 ft. 6 in., which leaves ample room for stoking and fuel. The boiler and brickwork enclosing it occupies a space of 5 ft. 6 in. by 4 ft. 3 in. by 4 ft. 9 in. high.

Such boilers are made of sizes for heating from 1,000 to 8,000 ft. of 4 in. pipes.

The following are a few of its specialities which can be strongly recommended:—

- 1st. Each unit is a complete boiler, therefore any requisite power can be obtained by increasing the number of units and area of fire grate.
- 2nd. Great economy in fuel. The construction of the boiler is such that the whole expenditure of fuel is made available for heating, and is applied in the most efficient manner possible; perfect combustion being secured.
- 3rd. The circulation of the water in the boiler is perfect, no matter on which side or part of the bottom the return is fixed.
- 4th. All deposit can be cleaned out of the boiler by the removal of the cover with which each horizontal tube is fitted.
- 5th. The fire front is fitted with a regulating register, by which the rate of combustion can be nicely adjusted. Coke, cinders, or coal may be used as fuel.

**IMPROVED SADDLE BOILER.**

The Boilers illustrated below will be found far superior to the ordinary Saddle boiler; the water back, horizontal flues, and bridge greatly increases the heating surface, and can be strongly recommended for their efficiency and economy.

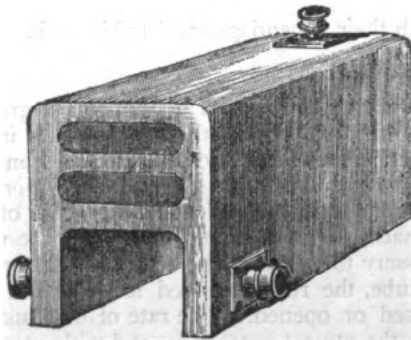

ELEVATION OF NO. 1 BOILER.

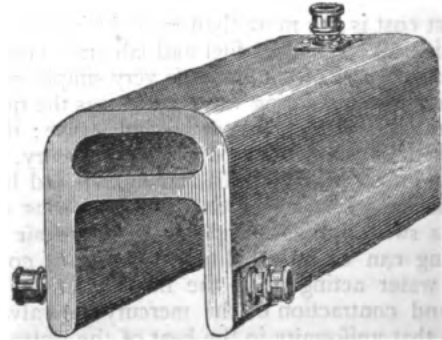

ELEVATION OF NO. 2 BOILER.

*GEORGE BOWER, ST. NEOTS, HUNTINGDONSHIRE.*

DIMENSIONS, POWER, AND PRICES OF WELDED BOILERS.

| No. 1 BOILER. |                                |       |                                        | No. 2 BOILER.    |    |    |       |                                |       |                                        |                  |    |    |
|---------------|--------------------------------|-------|----------------------------------------|------------------|----|----|-------|--------------------------------|-------|----------------------------------------|------------------|----|----|
| Long.         | Size of Boiler Outside Measure |       | Estimated Heating Power in 4-in. Pipe. | Price of Boiler. |    |    | Long. | Size of Boiler Outside Measure |       | Estimated Heating Power in 4-in. Pipe. | Price of Boiler. |    |    |
| in.           | wide.                          | high. | ft.                                    | £                | s. | d. | in.   | wide.                          | high. | ft.                                    | £                | s. | d. |
| 24            | 19                             | by 30 | 1100                                   |                  |    |    | 24    | 19                             | by 24 | 800                                    |                  |    |    |
| 30            | 21                             | " 32  | 1600                                   |                  |    |    | 30    | 21                             | " 26  | 1200                                   |                  |    |    |
| 36            | 23                             | " 35  | 2150                                   |                  |    |    | 36    | 23                             | " 29  | 1600                                   |                  |    |    |
| 42            | 24                             | " 40  | 2700                                   |                  |    |    | 42    | 24                             | " 32  | 2000                                   |                  |    |    |
| 48            | 26                             | " 40  | 3500                                   |                  |    |    | 48    | 26                             | " 32  | 2500                                   |                  |    |    |
| 54            | 27                             | " 42  | 4500                                   |                  |    |    | 54    | 27                             | " 34  | 3000                                   |                  |    |    |
| 60            | 28                             | " 45  | 5500                                   |                  |    |    |       |                                |       |                                        |                  |    |    |
| 66            | 30                             | " 45  | 6500                                   |                  |    |    |       |                                |       |                                        |                  |    |    |
| 72            | 32                             | " 45  | 7500                                   |                  |    |    |       |                                |       |                                        |                  |    |    |

PLANS AND ESTIMATES

Given for the complete Heating of all kinds of Buildings, from the smallest to the largest, either by Hot Water, Steam, Hot Air, or by combined Hot Air and Water Apparatus.

THE VENTILATING WARM AIR APPARATUS

Is made of best wrought-iron Plates, carefully rivetted together, and lined inside with fire-bricks, so that the fire cannot come in contact with the metal surfaces and plates over which the fire passes; the air cannot therefore be superheated, but is delivered into the building retaining its purity. Provision is made for maintaining the moisture of the air, and perfect ventilation may be secured in conjunction with this mode of heating.

The Apparatus is fitted with ash-pit door and register, by which the rate of combustion can be regulated.

COMBINED AIR AND WATER APPARATUS.

This system is recommended for large buildings as an efficient method of heating, and somewhat less costly than hot water alone. The Boiler is so arranged that the fire used in the Air Apparatus heats the water for circulation.

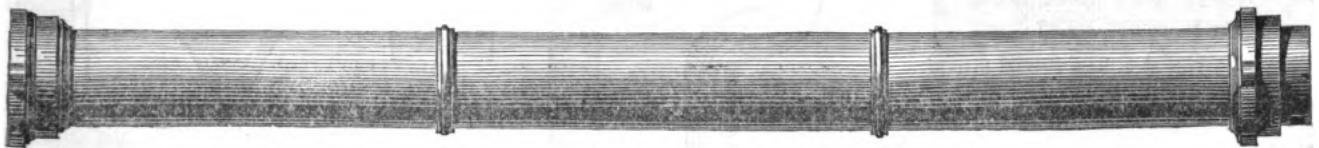

HOT WATER PIPES WITH IMPROVED JOINTS.

These drawings represent pipes with improved joints, especially made and used for hot water work. The joint is made with an india-rubber ring tightened up with two bolts. They can be fixed with much greater facility than the ordinary socket pipes without risk of leaky joints. A pipe can be cut to any desired length, and connected to a socket by means of a rubber ring and gland, at the same time forming an expansion joint. They can be easily disconnected without breaking a pipe or cutting out a joint, a necessary process with the common socket pipe. Pipe coils made upon the same principle can be put together in a few minutes, which would occupy hours to make with the caulked joint.

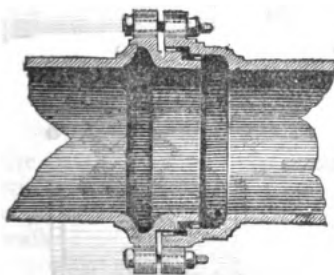

SECTION OF JOINT.

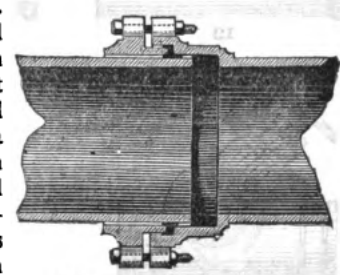

JOINT MADE WITH RING AND GLAND.

GEORGE BOWER, ST. NEOTS, HUNTINGDONSHIRE.

COMMON HOT WATER PIPES.



PATENT HOT WATER PIPE CONNECTIONS.

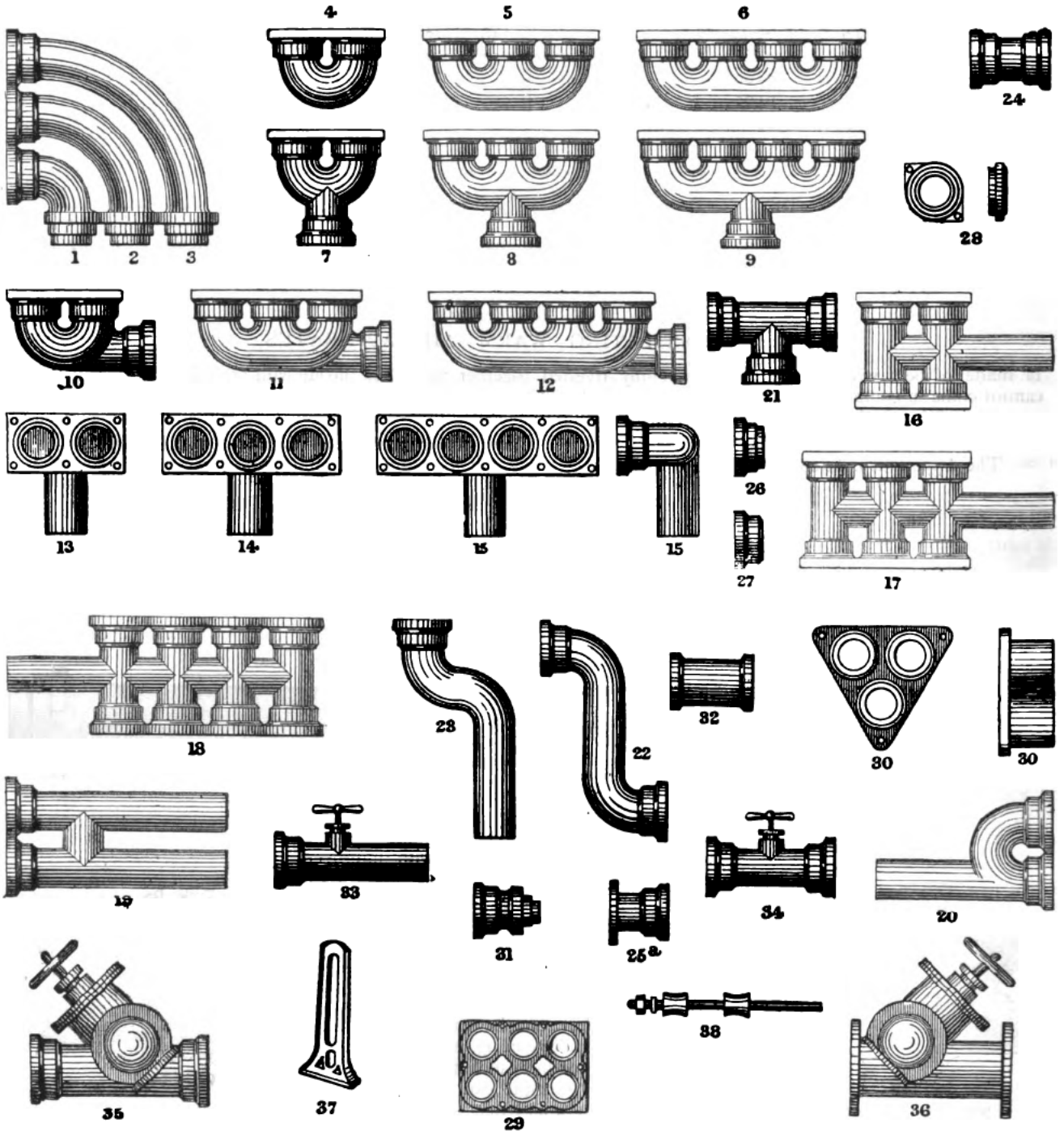

PRICE LIST OF PATENT HOT WATER PIPES, CONNECTIONS,  
AND FITTINGS.

| No. | Inside Diameter.            | 2 in. | 3 in. | 4 in. | 5 in. | 6 in. | No. | Inside Diameter.      | 2 in. | 3 in. | 4 in. | 5 in. | 6 in. |
|-----|-----------------------------|-------|-------|-------|-------|-------|-----|-----------------------|-------|-------|-------|-------|-------|
| *   | Pipes 9 ft. lengths pr. yd. |       |       |       |       |       | 19  | H Pipe                | each  |       |       |       |       |
| *   | " 6 ft. " "                 |       |       |       |       |       | 20  | Y Pipe                | "     |       |       |       |       |
| 1   | Inside Elbow                |       |       |       |       |       | 21  | T Piece               | "     |       |       |       |       |
| 2   | Middle " "                  |       |       |       |       |       | 22  | S Bend                | "     |       |       |       |       |
| 3   | Outside " "                 |       |       |       |       |       | 23  | Swan Necks            | "     |       |       |       |       |
| 4   | Close Syphon                |       |       |       |       |       | 24  | Double Socket         | "     |       |       |       |       |
| 5   | 3-way " "                   |       |       |       |       |       | 25  | Flange " "            | "     |       |       |       |       |
| 6   | 4-way " "                   |       |       |       |       |       | 26  | Male Cap              | "     |       |       |       |       |
| 7   | Outlet Syphon               |       |       |       |       |       | 27  | Female " "            | "     |       |       |       |       |
| 8   | 3-way " "                   |       |       |       |       |       | 28  | Glands                | "     |       |       |       |       |
| 9   | 4-way " "                   |       |       |       |       |       | 29  | Box End and Gland     | "     |       |       |       |       |
| 10  | Elbow Syphon                |       |       |       |       |       | 30  | Box End & Gland Piece | "     |       |       |       |       |
| 11  | 3-way " "                   |       |       |       |       |       | 31  | Reducing Socket.      | "     |       |       |       |       |
| 12  | 4-way " "                   |       |       |       |       |       | 32  | Slip Socket           | "     |       |       |       |       |
| 13  | Side outlet Syphon          |       |       |       |       |       | 33  | Throttle Valve        | "     |       |       |       |       |
| 14  | 3-way " "                   |       |       |       |       |       | 34  | " " "                 | "     |       |       |       |       |
| 15  | 4-way " "                   |       |       |       |       |       | 35  | Stop Valve            | "     |       |       |       |       |
| 16  | 4-way Branch Pipes.         |       |       |       |       |       | 36  | " " "                 | "     |       |       |       |       |
| 17  | 6-way " "                   |       |       |       |       |       | 37  | A Standard            | "     |       |       |       |       |
| 18  | 8-way " "                   |       |       |       |       |       | 38  | Bar and Rollers       | "     |       |       |       |       |

The outlet syphons of all kinds, as also the branch pipes and T pieces, are made equal or diminishing, as may be required.

FLOOR PIPE.

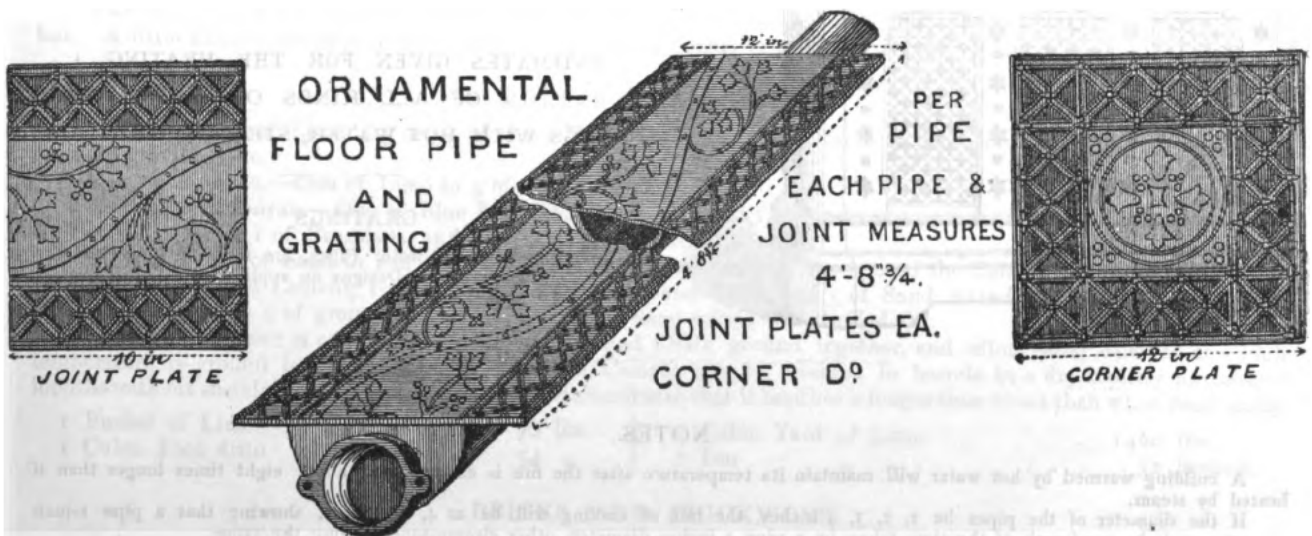

The Floor Pipe is D shaped in section, the upper face being made ornamental, the wings forming gratings for the passage of air. The joints of the pipes are made with india-rubber rings and bolts, each joint being covered with a joint-plate. At the angles a bend is used, connected and jointed in the same manner, and covered by an angle plate. The ornamental portion of the Pipe and Grating is slightly raised, presenting a rough surface to be walked over.

When used in a tiled floor the wings should rest on a cast-iron curb, made to receive the pipe on one side and the tiles on the other.

COILS PLAIN AND ORNAMENTAL, . COIL CASES AND GRATINGS.

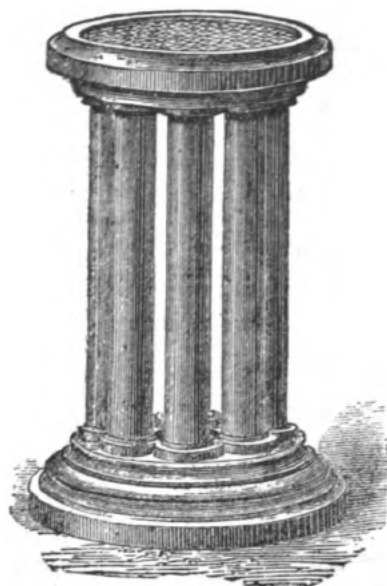

CIRCULAR COIL, NO BOLTS VISIBLE.

Pipe Coils, made either circular or flat, with India rubber joints, are much preferred to those put together with caulked joints. The bolts for tightening up the joints pass through the pipes and are not visible. A coil can be put together on this plan in a few minutes, which would occupy hours with caulked joints. The flat coils are made either plain or ornamental, of almost any length, one, two, or three pipes deep, and from two to six inches high.

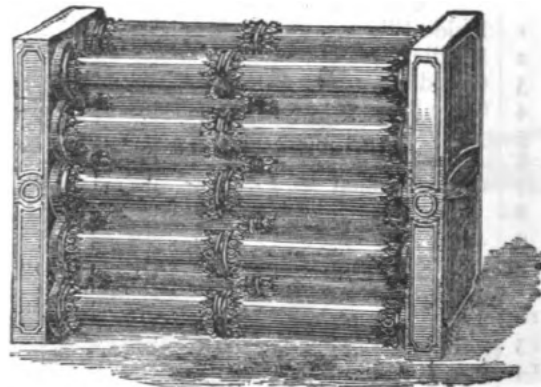

ORNAMENTAL COIL.

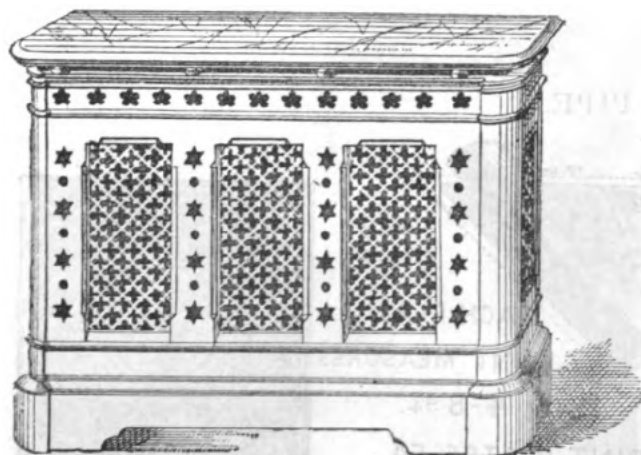

The annexed engraving illustrates an ordinary and inexpensive kind of Coil Case; but they may be had in a variety of patterns, and in very elaborate designs.

ESTIMATES GIVEN FOR THE HEATING  
OF ALL KINDS OF  
BUILDINGS WITH HOT WATER, STEAM, OR HOT AIR.

GRATINGS

For covering over Hot-water Pipes, are made in a variety of Patterns. Designs on application.

NOTES.

A building warmed by hot water will maintain its temperature after the fire is extinguished about eight times longer than if heated by steam.

If the diameter of the pipes be 1, 2, 3, 4 inches, the rate of cooling will be as 4, 2, 1.3, 1, showing that a pipe 1-inch diameter cools in one-fourth of the time taken by a pipe 4 inches diameter, other circumstances being the same.

The diameter of the pipes ought never to exceed 4 inches. When heat is to be maintained for a great length of time, as in hot-houses, 4-inch pipes are the best; for dwelling-houses, factories, etc., 2-inch or 3-inch pipes are preferable, as the heat may be quickly got up, and with considerable intensity.

The water contained in a pipe 4 inches diameter and  $\frac{1}{4}$ -inch thick, loses .851 degrees of heat per minute, when its temperature exceeds that of the surrounding atmosphere by 125°.

It is ascertained that a cubic foot of water, by losing a certain amount of its heat, measured in degrees, raises the temperature of 2990 cubic feet of air through the same number of degrees; therefore, one foot in length of pipe 4-inches diameter will heat 222 cubic feet of air one degree per minute, when the difference between the pipe and the air is 125°.

With regard to the change of air necessary for ventilation, 3½ cubic feet per minute is considered necessary for each individual (though some persons consider 10 feet necessary), and to counteract the cooling effect of glass, 1½ cubic feet per minute are required to be heated for each square foot of glass.



[ W ]

USEFUL MEMORANDA, TABLES, ETC.

EXCAVATION.

NATURAL SLOPES OF EARTHS WITH HORIZONTAL LINE.

|                           |     |                           |     |
|---------------------------|-----|---------------------------|-----|
| Compact Earth . . . . .   | 50° | Dry Sand . . . . .        | 38° |
| Clay, dry . . . . .       | 45° | Vegetable Earth . . . . . | 28° |
| Gravel, average . . . . . | 40° | Sand, wet . . . . .       | 22° |
| Shingle . . . . .         | 39° | Clay, wet . . . . .       | 16  |

WEIGHT OF A CUBIC YARD OF VARIOUS EARTHS.

|                  |               |                             |               |
|------------------|---------------|-----------------------------|---------------|
| Chalk . . . . .  | about 36 cwt. | Marl . . . . .              | about 26 cwt. |
| Clay . . . . .   | " 31 "        | Mud . . . . .               | " 25 "        |
| Gravel . . . . . | " 30 "        | Earths, Vegetable . . . . . | " 17 "        |
| Sand . . . . .   | " 30 "        |                             |               |

In loose ground a man can throw up about 10 cubic yards per day ; hard or gravelly soil about 5 cubic yards per day.

Three men will remove about 30 cubic yards a distance of 20 yards per day.

A dobbin cart will hold about  $\frac{3}{4}$  cubic yard ; a wheelbarrow,  $\frac{1}{8}$  yard ; an earth waggon,  $1\frac{1}{2}$  yards.

CONCRETE.

Seven parts Ballast or Unscreened Gravel to 1 Lime or Portland Cement ; or,  
Six parts Broken Stone, 2 parts Sand, 1 part Ground Lime or Portland Cement.  
Concrete to be mixed in small quantities and used fresh.

TAR CONCRETE.

Twelve gallons Tar to each cubic yard of broken Stone or Gravel. The Gravel to be quite dry and the Tar made hot. A little Pitch is an improvement, and Lime, about a bushel to every 12 gallons of Tar, is frequently added.

MORTAR, CEMENT, ETC.

MORTAR.—One of Lime to 3 or  $3\frac{1}{2}$  of sharp River Sand ; or, 1 of Lime to 2 Sand, and 1 Blacksmith's Ashes or coarsely ground Coke.

COARSE MORTAR.—One of Lime to 4 of coarse Gravelly Sand.

HYDRAULIC MORTAR.—One of Blue Lias Lime to  $2\frac{1}{2}$  of Burnt Clay, ground together ; or, one of Blue Lias Lime to 6 of sharp Sand, 1 of Puzzolana, and 1 of calcined Ironstone.

CEMENT.—One of Sand to 1 of Cement, but if the greatest tenacity is required the Cement should be used alone. —Waterproof Mastic Cement, 1 of Red Lead to 5 of ground Lime, and 5 of Sand mixed with Boiled Linseed Oil ; or, 1 of Red Lead to 5 of ground Lime, and 5 of sharp Sand mixed with Boiled Oil.

PORTLAND CEMENT is comprised of Clayey Mud and Chalk ground together, and after being calcined at a high temperature is ground to a fine powder. Portland Cement can be retained in barrels in a dry locality for several months without sustaining any injury, beyond the circumstance that it requires a longer time to set than when fresh made.

|                              |         |                                |             |
|------------------------------|---------|--------------------------------|-------------|
| 1 Bushel of Lime . . . . .   | 70 lbs. | 1 Cubic Yard of Lime . . . . . | 1460 lbs.   |
| 1 Cubic Foot ditto . . . . . | 54 "    | 1 Ton " " . . . . .            | 32 bushels. |

BRICKS AND BRICKWORK.

|                                                     |                                                                 |
|-----------------------------------------------------|-----------------------------------------------------------------|
| Usual dimensions of Bricks, London Stocks . . . . . | 8 $\frac{1}{2}$ in. × 4 $\frac{1}{2}$ in. × 2 $\frac{3}{4}$ in. |
| " " " Fire Bricks . . . . .                         | 9 " 4 $\frac{1}{2}$ " 2 $\frac{3}{4}$ "                         |
| " " " Paving . . . . .                              | 9 " 4 $\frac{1}{2}$ " 1 $\frac{1}{2}$ "                         |

One rod of Brickwork requires 4,356 Stock Bricks and about 50 to 60 cubic feet mortar, and is equal to 16 $\frac{1}{2}$  ft. × 16 $\frac{1}{2}$  ft. × 1 $\frac{1}{8}$  ft. = 306.28 cubic feet or 11.34 cubic yards ; or equal to 272 superficial feet of 1 $\frac{1}{2}$  brick in thickness.

The weight of a rod of brickwork in mortar = 15 $\frac{1}{2}$  tons.

A bricklayer's hod will hold 16 bricks, or  $\frac{3}{8}$  cubic foot of mortar.

One load of mortar = 1 cubic yard, and will fill 40 hods.

To reduce cubic feet to superficial feet of standard thickness, deduct  $\frac{1}{8}$ th.

To reduce superficial feet of brickwork 9 inches thick to standard thickness, deduct  $\frac{1}{8}$ rd.

BRICKS AND BRICKWORK—continued

|                                                            |                                                   |
|------------------------------------------------------------|---------------------------------------------------|
| Paving laid flat requires 32 Stock Bricks per yard, super. | Ordinary Stock Bricks weigh 60 cwt. per thousand. |
| " on edge " 36 Paving " "                                  | Fire Bricks " 65 to 70 "                          |
| " " 82 " " "                                               | Paving Bricks " 45 to 50 "                        |

NAMES, DIMENSIONS, AND WEIGHTS OF ROOFING SLATES MOST GENERALLY USED.

| Name.                 | Size in Inches. | No. to Cover 1 Square. | Weight per 1,000 in cwt. | Distance for Lath on Iron Roofs. |
|-----------------------|-----------------|------------------------|--------------------------|----------------------------------|
| Princess . . . . .    | 24 x 14         | 120                    | 66.5 to 75               | 10.5                             |
| Duchess . . . . .     | 24 x 12         | 125                    | 57 " 60                  | 10.5                             |
| Marchioness . . . . . | 22 x 12         | 130                    | 52.5 " 54                | 9.5                              |
| Countess . . . . .    | 20 x 10         | 171                    | 38 " 40                  | 8.5                              |
| Viscountess . . . . . | 18 x 10         | 200                    | 33 " 35                  | 7.5                              |

CORRUGATED IRON ROOFING.

| Birmingham Wire Gauge. | Size of Sheet.                 | Weight per Square, in cwt., grs., lbs. | Square feet per Ton. |
|------------------------|--------------------------------|----------------------------------------|----------------------|
| 16                     | 6 ft. x 2 ft. to 8 ft. x 3 ft. | 3 0 14                                 | 800                  |
| 18                     | " " "                          | 2 1 6                                  | 1000                 |
| 20                     | " " "                          | 1 3 6                                  | 1250                 |
| 22                     | " " 7 ft. x 2 ft. 6 in         | 1 2 7                                  | 1550                 |

NOTE.—The Sheets should not have less than 6-in. lap, and be double rivetted,  $\frac{1}{8}$  of weight allowed for lappage. Three pounds rivets required per square. Lathes or purlins should be from 5 to 6 feet apart.

STORAGE OF COAL AND COKE.

Space occupied by 1 ton in weight:—

|                             |                      |                            |                |
|-----------------------------|----------------------|----------------------------|----------------|
| Welsh, Steam Coal . . . . . | 40 to 42 cubic feet. | Scotch, Gas Coal . . . . . | 46 cubic feet. |
| " House " . . . . .         | 44 " "               | Coke, Gas . . . . .        | 70 "           |
| Newcastle, Gas . . . . .    | 44 " "               |                            |                |

CEMENTS FOR JOINTING RETORT MOUTHPIECES FOR CLAY RETORTS.

Three-fourths by weight, of ground fire clay. One-fourth by weight, of iron borings.

CONDENSATION.

At least 4.5 square feet of condensing surface should be provided for every 1,000 cubic feet of gas made per diem.

EVAPORATION FROM WATER SURFACES.

|                    |                      |                             |                      |
|--------------------|----------------------|-----------------------------|----------------------|
| In March . . . . . | .033 inches per day. | In June . . . . .           | .075 inches per day. |
| " April . . . . .  | .055 " "             | " July . . . . .            | .122 " "             |
| " May . . . . .    | .063 " "             | " Hottest Weather . . . . . | .200 " "             |

RELATIVE EFFECT OF AIR AND WATER IN COOLING.

| Excess in Temperature of Gas over the Atmosphere. | Quantity of Heat lost by a square unit of exterior pipe surface. In Air. | In Water. |
|---------------------------------------------------|--------------------------------------------------------------------------|-----------|
| 10° . . . . .                                     | 8 . . . . .                                                              | 88        |
| 20° . . . . .                                     | 18 . . . . .                                                             | 266       |
| 30° . . . . .                                     | 29 . . . . .                                                             | 5,353     |
| 40° . . . . .                                     | 40 . . . . .                                                             | 8,944     |
| 50° . . . . .                                     | 53 . . . . .                                                             | 13,437    |

WEIGHT AND PRESSURE OF GASHOLDERS.

To ascertain the weight of a Gasholder from the pressure it gives in 10ths of an inch.

$$\text{Diameter}^2 \times \text{No. of 10ths pressure} \times .4091 = \text{weight of Gasholder in lbs.}$$

To ascertain the pressure in 10ths of an inch.

$$\frac{\text{lbs. weight of Gasholder}}{\text{Diameter}^2 \times .4091} = \text{pressure in 10ths.}$$

SPECIFIC GRAVITY, WEIGHT, TENACITY, AND CRUSHING FORCE OF VARIOUS MATERIALS.

| Description.           | Specific Gravity. | Weight per cubic ft. in inches. | Tenacity in lbs. per square inch. | Crushing Force in lbs. per sq. in. | Description.            | Specific Gravity. | Weight per cubic feet in inches. | Tenacity in lbs. per square inch. | Crushing Force in lbs. per sq. in. |
|------------------------|-------------------|---------------------------------|-----------------------------------|------------------------------------|-------------------------|-------------------|----------------------------------|-----------------------------------|------------------------------------|
| ARTIFICIAL SUBSTANCES. |                   |                                 |                                   |                                    | STONES, ETC.—continued. |                   |                                  |                                   |                                    |
| Brick                  | 2.0               | 124                             | 290                               | 1500                               | Coke                    | .8                | 50                               | ....                              | ....                               |
| Brickwork in Mortar    | 1.6               | 100                             | ....                              | ....                               | Earth (rammed)          | 1.6               | 100                              | ....                              | ....                               |
| "    Cement            | 1.8               | 112 to 94                       | 290                               | 1000                               | Flint                   | 2.6               | 162                              | ....                              | ....                               |
| Concrete, ordinary     | 1.9               | 119                             | ....                              | ....                               | Gravel                  | 1.9               | 120                              | ....                              | ....                               |
| Concrete in Cement     | 2.2               | 133                             | ....                              | ....                               | Granite                 | 2.6               | 164                              | ....                              | ....                               |
| Cement, Portland       | 1.3               | 81                              | ....                              | ....                               | Grindstone              | 2.1               | 131                              | ....                              | ....                               |
| Cement, Roman          | 1.0               | 63                              | ....                              | ....                               | Limestone               | 2.5               | 156                              | ....                              | 3000 to 8000                       |
| Glass                  | 2.5               | 156                             | 9000                              | ....                               | Marble                  | 2.7               | 168                              | 6000                              | 6000                               |
| Lime, Quick            | .8                | 50                              | ....                              | ....                               | Land                    | 1.9               | 120                              | ....                              | ....                               |
| Mortar                 | 1.7               | 106                             | ....                              | ....                               | Sandstone               | 2.5               | 156                              | ....                              | 5000                               |
| Tile                   | 1.8               | 112                             | ....                              | ....                               | Stone, Bath             | 1.8               | 112                              | ....                              | ....                               |
| STONES, EARTHS, ETC.   |                   |                                 |                                   |                                    | Stone, Portland         | 2.1               | 131                              | ....                              | 3700                               |
| Chalk                  | 2.3               | 143                             | ....                              | ....                               | York Flag               | 2.3               | 143                              | ....                              | ....                               |
| Clay                   | 2.0               | 125                             | ....                              | ....                               | Slate                   | 2.8               | 175                              | ....                              | 11000                              |
| Coal                   | 1.3               | 82                              | ....                              | ....                               | Shingle                 | 1.4               | 90                               | ....                              | ....                               |

MOLESWORTH'S Pocket Book.

PRESSURE OF WATER AGAINST WALLS, BOTTOM AND SIDES OF CISTERNS, ETC.

A = area of surface pressed in feet.  
 H = depth of centre of gravity below surface in feet.  
 Pressure in lbs. = 62.5 A.H.

The pressure may be considered as acting at a point two-thirds of the total depth from the top.

TO FIND THE FORCE OF WATER IMPINGING AGAINST A PLANE SURFACE.

Force in lbs. = surface in square feet x velocity<sup>2</sup> in feet per second x C.

VALUES OF C. AT VARIOUS ANGLES:—

|                               |                          |                          |
|-------------------------------|--------------------------|--------------------------|
| At right angles, or 90° = .98 | At an angle of 60° = .86 | At an angle of 30° = .33 |
| At an angle of 80° = .96      | "    50° = .74           | "    20° = .16           |
| "    70° = .93                | "    40° = .57           | "    10° = .06           |

TABLE OF VELOCITY AND PRESSURE OF WINDS.

| Designation.  | Velocity in Miles per Hour. V. | Pressure in lbs. per square foot. P. |
|---------------|--------------------------------|--------------------------------------|
| Perceptible   | 2                              | .020                                 |
| Slight breeze | 4                              | .080                                 |
| Moderate "    | 8                              | .320                                 |
| Fresh "       | 15                             | 1.125                                |
| Brisk wind    | 25                             | 3.125                                |
| Strong "      | 30                             | 4.50                                 |
| High "        | 40                             | 8.00                                 |
| Storm         | 50                             | 12.50                                |
| Violent ditto | 60                             | 18.00                                |
| Hurricane     | 80                             | 32.00                                |
| Violent ditto | 100                            | 50.00                                |

Let P equal pressure of wind in lbs. per square foot against a surface perpendicular to its direction.

$$V = \text{velocity in miles per hour.} \quad P = \frac{V^2}{200}$$

CORRESPONDING DEGREES OF TEMPERATURE OF FAHRENHEIT, REAUMUR, AND THE CENTIGRADE SCALE.

| Fahr. | Reau. | Centig. | Fahr. | Reau. | Centig. | Fahr. | Reau.  | Centig. |
|-------|-------|---------|-------|-------|---------|-------|--------|---------|
| 212°  | 80°   | 100°    | 232°  | 88.9° | 111.1°  | 260°  | 101.3° | 126.6°  |
| 214   | 80.9  | 101.1   | 234   | 89.8  | 112.2   |       |        |         |
| 216   | 81.8  | 102.2   | 236   | 90.7  | 113.3   | 270   | 105.8  | 135.2   |
| 218   | 82.7  | 103.3   | 238   | 91.6  | 114.4   |       |        |         |
| 220   | 83.6  | 104.4   | 240   | 92.4  | 115.5   | 280   | 110.2  | 137.8   |
| 222   | 84.4  | 105.6   | 242   | 93.3  | 116.6   |       |        |         |
| 224   | 85.3  | 106.7   | 244   | 94.2  | 117.7   | 290   | 114.7  | 143.3   |
| 226   | 86.2  | 107.8   | 246   | 95.1  | 118.8   | 300   | 119.1  | 148.9   |
| 228   | 87.1  | 108.9   | 248   | 96.0  | 120.0   | 320   | 128.0  | 160.0   |
| 230   | 88.0  | 110.0   | 250   | 96.9  | 121.1   | 350   | 141.3  | 176.7   |

TO CONVERT DEGREES FAHRENHEIT INTO REAUMUR OR CENTIGRADE, AND VICE VERSA.

$$\frac{\text{Degrees Fahrenheit}-32}{2.25} = \text{Reaumur} \qquad \frac{\text{Degrees Fahrenheit}-32}{1.8} = \text{Centigrade.}$$

$$\text{Reaumur} \times 2.25 + 32 = \text{Fahrenheit.}$$

$$\text{Centigrade} \times 1.8 + 32 = \text{Fahrenheit.}$$

See Table on Page 163.

VELOCITY OF SOUND.

At 40° Fahrenheit = 1102 feet per second.      At 70° Fahrenheit = 1135 feet per second.  
 " 50      "      = 1113      "      " 80      "      = 1146      "  
 " 60      "      = 1124      "      "

TABLE OF NUMBER OF HOURS GAS IS BURNT EACH MONTH, QUARTER, AND YEAR.

|                           | July | August | September | October | November | December | January | February | March | April | May | June | Midsummer Quarter | Michaelmas Quarter | Christmas Quarter | Lady-Day Quarter | Total Yearly |
|---------------------------|------|--------|-----------|---------|----------|----------|---------|----------|-------|-------|-----|------|-------------------|--------------------|-------------------|------------------|--------------|
| From dark to 6 o'clock .  | ..   | ..     | 2         | 31      | 62       | 80       | 65      | 33       | 4     | ..    | ..  | ..   | ..                | ..                 | 173               | 102              | 277          |
| " 7 " " .                 | ..   | 14     | 22        | 62      | 92       | 111      | 96      | 61       | 31    | 4     | ..  | ..   | 4                 | 37                 | 265               | 181              | 493          |
| " 8 " " .                 | ..   | 40     | 52        | 93      | 122      | 142      | 127     | 89       | 62    | 28    | 4   | ..   | 32                | 92                 | 357               | 278              | 759          |
| " 9 " " .                 | 13   | 70     | 82        | 124     | 152      | 173      | 158     | 117      | 93    | 58    | 29  | 8    | 95                | 166                | 449               | 368              | 1078         |
| " 10 " " .                | 44   | 102    | 112       | 155     | 182      | 204      | 189     | 145      | 124   | 88    | 60  | 38   | 136               | 258                | 541               | 458              | 1443         |
| " 11 " " .                | 95   | 133    | 142       | 186     | 212      | 285      | 220     | 173      | 155   | 111   | 91  | 68   | 277               | 350                | 633               | 548              | 1808         |
| " 12 " " .                | 106  | 164    | 172       | 217     | 248      | 266      | 251     | 201      | 186   | 148   | 122 | 98   | 368               | 442                | 725               | 638              | 2173         |
| All night .               | ..   | 307    | 345       | 421     | 473      | 527      | 512     | 411      | 382   | 295   | 242 | 195  | 732               | 869                | 1421              | 1305             | 4327         |
| Morning, from 4 o'clock . | ..   | 16     | 48        | 80      | 110      | 137      | 137     | 98       | 71    | 28    | 2   | ..   | 30                | 64                 | 327               | 306              | 727          |
| " 5 " " .                 | ..   | ..     | 18        | 49      | 80       | 106      | 106     | 70       | 40    | 3     | ..  | ..   | 3                 | 18                 | 235               | 216              | 472          |
| " 6 " " .                 | ..   | ..     | ..        | 18      | 50       | 75       | 75      | 42       | 9     | ..    | ..  | ..   | ..                | ..                 | 142               | 126              | 269          |
| " 7 " " .                 | ..   | ..     | ..        | ..      | 20       | 44       | 44      | 14       | ..    | ..    | ..  | ..   | ..                | ..                 | 64                | 58               | 122          |

ENGLISH WEIGHTS & MEASURES, WITH METRICAL EQUIVALENTS.

MEASURES OF WEIGHT.

TROY.

|       |   |        |   |                   |   |               |   |                 |                                                                                                                          |
|-------|---|--------|---|-------------------|---|---------------|---|-----------------|--------------------------------------------------------------------------------------------------------------------------|
| 1 lb. | = | 12 oz. | = | 240 penny weight. | = | 5,760 grains. | = | 372.96 grammes. | 175 lbs. troy = 144 lbs. avoirdupois.<br>lbs. avoirdupois x .82,216 = lb. troy.<br>lbs. troy x 1.2153 = lb. avoirdupois. |
| 1 lb. | = | 1 oz.  | = | 20 dwt.           | = | 480 gr.       | = | 31.08 gr.       |                                                                                                                          |
|       |   |        | = | 1 penny weight.   | = | 24 gr.        | = | 1.55 gr.        |                                                                                                                          |
|       |   |        | = | 1 dwt.            | = | 1 gr.         | = | 0.648 gr.       |                                                                                                                          |

AVOIRDUPOIS.

|        |   |         |   |             |   |            |   |           |   |            |   |                |   |                    |
|--------|---|---------|---|-------------|---|------------|---|-----------|---|------------|---|----------------|---|--------------------|
| 1 ton. | = | 20 cwt. | = | 80 quarter. | = | 160 stone. | = | 2,240 lb. | = | 35,840 oz. | = | 573,440 drams. | = | 1,026,048 grammes. |
|        |   | 1 cwt.  | = | 4 quarter.  | = | 8 stone.   | = | 112 lb.   | = | 1,792 oz.  | = | 28,672 drams.  | = | 50,802 grammes.    |
|        |   |         | = | 1 quarter.  | = | 2 stone.   | = | 28 lb.    | = | 448 oz.    | = | 7,168 drams.   | = | 12,702 grammes.    |
|        |   |         | = |             | = | 1 stone.   | = | 14 lb.    | = | 224 oz.    | = | 3,584 drams.   | = | 6,350.26 grammes.  |
|        |   |         | = |             | = |            | = | 1 lb.     | = | 16 oz.     | = | 256 drams.     | = | 453.59 grammes.    |
|        |   |         | = |             | = |            | = |           | = | 1 oz.      | = | 16 drams.      | = | 28.35 grammes.     |
|        |   |         | = |             | = |            | = |           | = |            | = | 1 dram.        | = | 1.77 grammes.      |

MEASURES OF LENGTH.

LONG MEASURE.

|         |   |             |   |            |   |               |   |              |   |             |   |                |   |                   |
|---------|---|-------------|---|------------|---|---------------|---|--------------|---|-------------|---|----------------|---|-------------------|
| 1 mile. | = | 8 furlongs. | = | 320 poles. | = | 880 fathoms.  | = | 1,760 yards. | = | 5,280 feet. | = | 63,360 inches. | = | 1,609.315 metres. |
|         |   | 1 furlong.  | = | 40 poles.  | = | 110 fathoms.  | = | 220 yards.   | = | 660 feet.   | = | 7,920 inches.  | = | 202.16 metres.    |
|         |   |             | = | 1 pole.    | = | 2.75 fathoms. | = | 5.5 yards.   | = | 26.5 feet.  | = | 198 inches.    | = | 5.029 metres.     |
|         |   |             | = |            | = | 1 fathom.     | = | 2 yards.     | = | 6 feet.     | = | 72 inches.     | = | 1.828 metres.     |
|         |   |             | = |            | = |               | = | 1 yard.      | = | 3 feet.     | = | 36 inches.     | = | .9144 metres.     |
|         |   |             | = |            | = |               | = |              | = | 1 foot.     | = | 12 inches.     | = | .3048 metres.     |
|         |   |             | = |            | = |               | = |              | = |             | = | 1 inch.        | = | .0254 metres.     |

MEASURES OF LENGTH—continued.

| LINEAL MEASURE. |                |               |              |              |                |                |           |
|-----------------|----------------|---------------|--------------|--------------|----------------|----------------|-----------|
| <i>mile.</i>    | <i>chains.</i> | <i>yards.</i> | <i>feet.</i> | <i>link.</i> | <i>inches.</i> | <i>mètres.</i> |           |
| 1               | = 80           | = 1,760       | = 5,280      | = 8,000      | = 63,360       | =              | 1,609'325 |
|                 | 1              | = 22          | = 66         | = 200        | = 792          | =              | 20'116    |
|                 |                | 1             | = 3          | = 4'545      | = 36           | =              | '9144     |
|                 |                |               | 1            | = 515        | = 12           | =              | '3048     |
|                 |                |               |              | 1            | = 7'92         | =              | '2012     |
|                 |                |               |              |              | 1              | =              | '0254     |

GEOGRAPHICAL MEASURE.

| <i>degrees.</i> | <i>knots or geographical miles.</i> | <i>yards.</i> | <i>feet.</i> | <i>statute miles.</i> | <i>mètres.</i> |
|-----------------|-------------------------------------|---------------|--------------|-----------------------|----------------|
| 1               | = 60                                | = 121,653'20  | = 364,959'60 | = 69'121              | = 111,240      |
|                 | 1                                   | = 2,027'55    | = 6,082'66   | = 1'152               | = 1,854        |

1 Admiralty Knot = 1'1515 statute mile = 6,082'6 feet.

1 Cable length = 1½ nautical mile = 608'26 feet.

SQUARE MEASURE.

| <i>acre.</i> | <i>roods.</i> | <i>poles or perches</i> | <i>yards.</i> | <i>feet.</i> | <i>inches.</i> | <i>sqare mètres.</i> |
|--------------|---------------|-------------------------|---------------|--------------|----------------|----------------------|
| 1            | = 4           | = 160                   | = 4,840       | = 43,560     | = 6,272,640    | = 4046'7             |
|              | 1             | = 40                    | = 1,210       | = 10,890     | = 1,568,160    | = 1'011'7            |
|              |               | 1                       | = 30.25       | = 272'25     | = 39,204       | = 25'29              |
|              |               |                         | 1             | = 9          | = 1,296        | = .8361              |
|              |               |                         |               | 1            | = 144          | = '0929              |

10 square chains = 1 acre.

1 mile, 1 chain wide = 8 acres.

CUBIC MEASURE.

| <i>cubic yard.</i> | <i>cubic feet.</i> | <i>cubic inches.</i> | <i>cubic mètres.</i> |
|--------------------|--------------------|----------------------|----------------------|
| 1                  | = 27               | = 46,656             | = '764,513           |
|                    | 1                  | = 1,728              | = '028,315           |

MEASURES OF CAPACITY—LIQUIDS.

| <i>gallon.</i> | <i>quart.</i> | <i>pint.</i> | <i>gill.</i> | <i>cu. inch.</i> | <i>French litres.</i> |
|----------------|---------------|--------------|--------------|------------------|-----------------------|
| 1              | = 4           | = 8          | = 32         | = 277'25         | = 3'78,515            |
|                | = 1           | = 2          | = 16         | = 69'318         | = '94,796             |
|                |               | 1            | = 4          | = 34'659         | = '47,398             |
|                |               |              | 1            | = 8'665          | = '11,849             |

FRENCH MEASURE, DECIMAL SYSTEM.

LONG MEASURE.

| <i>French.</i>       | <i>English.</i> | <i>French.</i>      | <i>English.</i>    |
|----------------------|-----------------|---------------------|--------------------|
| Millimètre . . . . . | = 0'0393 inch.  | Decametre 10 metres | = 32'809 feet.     |
| Centimètre . . . . . | = 0'3937 "      | Hectometre 100 "    | = 328'09 "         |
| Decametre . . . . .  | = 3'9371 "      | Kilometre 1,000 "   | = 1093'6389 yards. |
| METRE . . . . .      | = 3'2809 feet.  | Myriametre 10,000 " | = 6'2138 miles.    |

SQUARE MEASURE.

| <i>French.</i>           | <i>English.</i>     | <i>French.</i>          | <i>English.</i>     |
|--------------------------|---------------------|-------------------------|---------------------|
| Milliare . . . . .       | = 155' sq. inches.  | ARE, a Square Decametre | = 119'60 sq. yards. |
| Centiare or square mètre | = 10'764 sq. feet.  | Decare . . . . .        | = 1196'046 " "      |
| Deciare . . . . .        | = 11'960 sq. yards. | Hectare . . . . .       | = 2'4712 acres.     |

CUBIC MEASURE.

| <i>French.</i>       | <i>English.</i>    | <i>French.</i>          | <i>English.</i>     |
|----------------------|--------------------|-------------------------|---------------------|
| Millistere . . . . . | = 61'028 cubic in. | CUBIC METRE, or STERE . | = 35'317 cubic ft.  |
| Centistere . . . . . | = 610'28 "         | Decastere . . . . .     | = 13'080 cubic yds. |
| Decistere . . . . .  | = 3'5317 cubic ft. | Hectostere . . . . .    | = 130'80 "          |

WEIGHTS.

| <i>French.</i>        | <i>English.</i>  | <i>French.</i>        | <i>English.</i>      |
|-----------------------|------------------|-----------------------|----------------------|
| Milligramme . . . . . | = 0'0154 grains. | Decogramme . . . . .  | = 154'34 grains.     |
| Centigramme . . . . . | = 0'1543 "       | Hectogramme . . . . . | = 3'527 ozs. avoird. |
| Decigramme . . . . .  | = 1'5434 "       | KILOGRAMME . . . . .  | = 2'2048 lbs.        |
| GRAMME . . . . .      | = 15'434 "       | Myriagramme . . . . . | = 22'048 "           |

DRY AND FLUID MEASURE.

| <i>French.</i>            | <i>English.</i>    | <i>French.</i>              | <i>English.</i>    |
|---------------------------|--------------------|-----------------------------|--------------------|
| Millilitre . . . . .      | = 0'0610 cubic in. | Decalitre . . . . .         | = 610'28 cubic in. |
| Centilitre . . . . .      | = 0'6103 "         | Hectolitre . . . . .        | = 3'5317 cubic ft. |
| Decilitre . . . . .       | = 6'1028 "         | Cubic Metre, or Kilolitre . | = 35'317 "         |
| LITRE, or cubic decimetre | = 61'028 "         |                             |                    |

”  
Thickness of plates in inch  
Thickness of plates in 8ths  
Sectional area in inches  $\times$   
Sectional area in 8ths of an  
Lbs. per lineal yard  $\times$  .7854  
Diameter of round iron in

WEIGHT OF A SQUARE FOOT OF SHEET METALS IN POUNDS.  
THICKNESS BIRMINGHAM WIRE GAUGE.

| Thickness<br>B. W. G. | Iron. | Copper. | Brass. | Thickness<br>B. W. G. | Iron. | Copper. | Brass. |
|-----------------------|-------|---------|--------|-----------------------|-------|---------|--------|
| 30                    | .5    | .58     | .55    | 15                    | 2.82  | 3.27    | 3.10   |
| 29                    | .56   | .64     | .61    | 14                    | 3.12  | 3.60    | 4.43   |
| 28                    | .64   | .74     | .70    | 13                    | 3.75  | 4.34    | 4.12   |
| 27                    | .72   | .83     | .79    | 12                    | 4.38  | 5.08    | 4.81   |
| 26                    | .80   | .92     | .88    | 11                    | 5.00  | 5.80    | 5.50   |
| 25                    | .90   | 1.04    | .99    | 10                    | 5.62  | 6.50    | 6.18   |
| 24                    | 1.00  | 1.16    | 1.10   | 9                     | 6.24  | 7.20    | 6.86   |
| 23                    | 1.12  | 1.30    | 1.23   | 8                     | 6.86  | 7.90    | 7.54   |
| 22                    | 1.25  | 1.45    | 1.37   | 7                     | 7.50  | 8.70    | 8.25   |
| 21                    | 1.40  | 1.62    | 1.54   | 6                     | 8.12  | 9.40    | 8.93   |
| 20                    | 1.54  | 1.78    | 1.69   | 5                     | 8.74  | 10.10   | 9.61   |
| 19                    | 1.70  | 1.97    | 1.87   | 4                     | 10.00 | 11.60   | 11.00  |
| 18                    | 1.86  | 2.15    | 2.04   | 3                     | 11.00 | 12.75   | 12.10  |
| 17                    | 2.18  | 2.52    | 2.40   | 2                     | 12.00 | 13.90   | 13.10  |
| 16                    | 2.50  | 2.90    | 2.75   | 1                     | 12.50 | 14.50   | 13.75  |

WEIGHT OF A SUPERFICIAL FOOT OF PLATES OF DIFFERENT METALS, IN POUNDS.

| Thickness.<br>Inches. | Iron. | Brass. | Copper. | Lead. | Zinc. | THICKNESS in decimals of<br>an inch and nearest B.W.G. |
|-----------------------|-------|--------|---------|-------|-------|--------------------------------------------------------|
| 1/16                  | 2.5   | 2.7    | 2.9     | 3.7   | 2.3   | .4625 in. = 16 B. W. G.                                |
| 1/8                   | 5.0   | 5.5    | 5.8     | 7.4   | 4.7   | .125 " = 11 "                                          |
| 3/16                  | 7.5   | 8.2    | 8.7     | 11.1  | 7.0   | .1875 " = 7 "                                          |
| 1/4                   | 10.0  | 11.0   | 11.6    | 14.8  | 9.4   | .25 " = 4 "                                            |
| 5/16                  | 12.5  | 13.7   | 14.5    | 18.5  | 11.7  | .3125 " = 1 "                                          |
| 3/8                   | 15.0  | 16.4   | 17.2    | 22.2  | 14.0  | .375 " = 00 "                                          |
| 7/16                  | 17.5  | 19.2   | 20.0    | 25.9  | 16.4  | .4375 "                                                |
| 1/2                   | 20.0  | 21.9   | 22.9    | 29.5  | 18.7  | .5 "                                                   |
| 5/8                   | 22.5  | 24.6   | 25.7    | 33.2  | 21.1  | .5625 "                                                |
| 3/4                   | 25.0  | 27.4   | 28.6    | 36.9  | 23.4  | .625 "                                                 |
| 7/8                   | 27.5  | 30.1   | 31.4    | 40.6  | 25.7  | .6875 "                                                |
| 1                     | 30.0  | 32.9   | 34.3    | 44.3  | 28.1  | .75 "                                                  |
| 1 1/8                 | 32.5  | 35.6   | 37.2    | 48.0  | 30.4  | .8125 "                                                |
| 1 1/4                 | 35.0  | 38.3   | 40.0    | 51.7  | 32.8  | .875 "                                                 |
| 1 1/2                 | 37.5  | 41.2   | 42.9    | 55.4  | 35.1  | .9375 "                                                |
| 1 3/4                 | 40    | 43.9   | 45.8    | 59.1  | 37.5  | 1.0000 "                                               |

WEIGHT OF ORDINARY ANGLE IRON.

| Breadth in inches       | In lbs. per lineal foot. |       |       |     |       |       |     |       |       |    |
|-------------------------|--------------------------|-------|-------|-----|-------|-------|-----|-------|-------|----|
|                         | 1 1/2                    | 1 1/2 | 1 1/2 | 2   | 2 1/2 | 2 1/2 | 3   | 3 1/2 | 3 1/2 |    |
| Weight per foot in lbs. | 1.8                      | 2.7   | 3.3   | 3.9 | 5     | 6.5   | 8.3 | 10.4  | 11.7  | 14 |

WEIGHT OF A LINEAL FOOT OF ROUND AND SQUARE BAR IRON, IN POUNDS.

| Diameter<br>or side parts<br>of inches. | Square Bar. |            | Diameter<br>or<br>Side Inches | Round Bar.  |            | Diameter<br>or<br>Side Inches | Round Bar.  |            |
|-----------------------------------------|-------------|------------|-------------------------------|-------------|------------|-------------------------------|-------------|------------|
|                                         | Square Bar. | Round Bar. |                               | Square Bar. | Round Bar. |                               | Square Bar. | Round Bar. |
| 1/4                                     | .209        | .164       | 1 1/4                         | 4.22        | 3.32       | 2 1/2                         | 27.61       | 21.68      |
| 3/16                                    | .326        | .256       | 1 1/2                         | 5.25        | 4.09       | 3                             | 30.07       | 23.66      |
| 1/8                                     | .470        | .369       | 1 3/8                         | 6.35        | 4.96       | 3 1/4                         | 35.28       | 27.70      |
| 5/16                                    | .640        | .502       | 1 1/2                         | 7.51        | 5.90       | 3 1/2                         | 40.91       | 32.13      |
| 3/8                                     | .835        | .656       | 1 3/4                         | 8.82        | 6.92       | 3 3/4                         | 46.97       | 36.89      |
| 7/16                                    | 1.057       | .831       | 1 1/2                         | 10.29       | 8.03       | 4                             | 53.44       | 41.97      |
| 1/2                                     | 1.305       | 1.025      | 1 3/4                         | 11.74       | 9.22       | 4 1/4                         | 60.32       | 47.38      |
| 5/8                                     | 1.579       | 1.241      | 2                             | 13.36       | 10.49      | 4 1/2                         | 67.63       | 53.12      |
| 3/4                                     | 1.879       | 1.476      | 2 1/4                         | 15.08       | 11.84      | 4 3/4                         | 75.35       | 59.18      |
| 7/8                                     | 2.205       | 1.732      | 2 1/2                         | 16.91       | 13.27      | 5                             | 83.51       | 65.58      |
| 1                                       | 2.556       | 2.011      | 2 3/4                         | 18.84       | 14.79      | 5 1/4                         | 92.46       | 72.30      |
| 1 1/8                                   | 2.936       | 2.306      | 2 1/2                         | 20.87       | 16.39      | 5 1/2                         | 101.03      | 79.35      |
| 1 1/4                                   | 3.34        | 2.62       | 2 3/4                         | 23.11       | 18.07      | 5 3/4                         | 114.43      | 86.73      |
| 1 1/2                                   |             |            | 2 1/2                         | 25.26       | 19.84      | 6                             | 120.24      | 94.43      |

WEIGHT OF LEAD AND COMPOSITION PIPES IN POUNDS PER LINEAL FOOT.

| Inside Diam. | Light. | Medium. | Strong. | Composition. |
|--------------|--------|---------|---------|--------------|
| 1/2 inch     | .334   | .425    | 1 lb.   | .027         |
| 3/4 "        | 1 lb.  | 1.2     | 1.34    | .0708        |
| 1 "          | 1.44   | 1.84    | 3.0     | 1.417        |
| 1 1/2 "      | 2.4    | 2.8     | 3.7     | 1.833        |
| 2 "          | 3.7    | 4.0     | 4.8     |              |
| 2 1/2 "      | 4.8    | 5.6     | 6.4     |              |

WEIGHT OF WROUGHT IRON TUBE PER 1000 LINEAL FEET.

| Inside Diam. | Weight.<br>Cwts. | Inside Diam. | Weight.<br>Cwts. | Inside Diam. | Weight. |
|--------------|------------------|--------------|------------------|--------------|---------|
| 1 inch.      | 2.5              | 1 inch.      | 16.0             | 2½ inch.     | 47.5    |
| "            | 3.66             | 1½ "         | 22.5             | 2½ "         | 59.5    |
| "            | 5.40             | 1¾ "         | 26.5             | 2¾ "         | 75.0    |
| "            | 7.97             | 2 "          | 35.0             | 3 "          | 82.5    |
| "            | 10.5             |              | 40.0             |              |         |

SAFE WORKING LOAD OF HEMP ROPES AND CHAINS.

| Good Hemp Ropes. |                    |      |      | Chains.         |                    |      |      |                   |               |      |      |
|------------------|--------------------|------|------|-----------------|--------------------|------|------|-------------------|---------------|------|------|
| Circum. of Rope  | Safe Working Load. |      |      | Circum. of Rope | Safe Working Load. |      |      | Diameter of Iron. | Working Load. |      |      |
| in.              | tons               | cwt. | qrs. | in.             | tons               | cwt. | qrs. | in.               | tons          | cwt. | qrs. |
| 1                | 0                  | 1    | 3    | 4½              | 2                  | 9    | 0    | 1                 | 0             | 0    | 0    |
| 1½               | 0                  | 2    | 3    | 5               | 2                  | 14   | 0    | 1½                | 1             | 1    | 0    |
| 2                | 0                  | 4    | 0    | 5½              | 2                  | 19   | 0    | 1¾                | 2             | 2    | 0    |
| 2½               | 0                  | 7    | 0    | 6               | 3                  | 4    | 0    | 2                 | 8             | 0    | 0    |
| 2¾               | 0                  | 9    | 0    | 6½              | 3                  | 9    | 0    | 2½                | 3             | 3    | 0    |
| 3                | 0                  | 11   | 0    | 6¾              | 3                  | 15   | 0    | 2¾                | 4             | 0    | 0    |
| 3½               | 0                  | 13   | 2    | 6¾              | 4                  | 4    | 0    | 3                 | 4             | 6    | 0    |
| 3¾               | 0                  | 18   | 3    | 7               | 4                  | 7    | 0    | 3½                | 5             | 5    | 0    |
| 4                | 1                  | 1    | 0    | 7½              | 4                  | 13   | 0    | 3¾                | 6             | 2    | 0    |
| 4½               | 1                  | 5    | 0    | 7¾              | 5                  | 0    | 0    | 4                 | 7             | 0    | 0    |
| 4¾               | 1                  | 8    | 2    | 8               | 5                  | 7    | 0    | 4½                | 8             | 0    | 0    |
| 5                | 1                  | 12   | 0    | 8½              | 5                  | 14   | 0    | 5                 | 9             | 0    | 0    |
|                  | 1                  | 16   | 0    | 8¾              | 6                  | 0    | 0    | 5½                | 10            | 0    | 0    |
|                  | 2                  | 0    | 0    | 8¾              | 6                  | 7    | 0    | 6                 | 11            | 0    | 0    |
|                  | 2                  | 4    | 0    | 9               | 6                  | 15   | 0    | 6½                | 12            | 0    | 0    |
|                  |                    |      |      |                 | 7                  | 3    | 0    |                   |               |      |      |

AREAS AND CIRCUMFERENCES OF CIRCLES, FROM ONE TO NINETY-NINE FEET.

| Diam. in ft. | Area ft. | Circum. ft. | Diam. in ft. | Area ft. | Circum. ft. | Diam. in ft. | Area ft. | Circum. ft. |
|--------------|----------|-------------|--------------|----------|-------------|--------------|----------|-------------|
| 1            | 7854     | 3.1416      | 34           | 907.92   | 106.81      | 67           | 3525.66  | 210.48      |
| 2            | 3.1416   | 6.2832      | 35           | 962.11   | 109.95      | 68           | 3631.68  | 213.62      |
| 3            | 7.0686   | 9.4248      | 36           | 1017.87  | 113.09      | 69           | 3739.28  | 216.77      |
| 4            | 12.5664  | 12.5664     | 37           | 1075.21  | 116.24      | 70           | 3848.46  | 219.91      |
| 5            | 19.6350  | 15.7080     | 38           | 1134.11  | 119.38      | 71           | 3959.20  | 223.05      |
| 6            | 28.2744  | 18.8496     | 39           | 1194.59  | 122.52      | 72           | 4071.51  | 226.19      |
| 7            | 38.4846  | 21.9912     | 40           | 1256.64  | 125.66      | 73           | 4185.39  | 229.33      |
| 8            | 50.2656  | 25.1328     | 41           | 1320.25  | 128.80      | 74           | 4300.85  | 232.47      |
| 9            | 63.6174  | 28.2744     | 42           | 1385.84  | 131.94      | 75           | 4417.87  | 235.62      |
| 10           | 78.5400  | 31.4160     | 43           | 1452.20  | 135.088     | 76           | 4536.47  | 238.76      |
| 11           | 95.0334  | 34.5576     | 44           | 1520.53  | 138.23      | 77           | 4656.63  | 241.91      |
| 12           | 113.0976 | 37.6992     | 45           | 1590.43  | 141.37      | 78           | 4778.37  | 245.05      |
| 13           | 132.7326 | 40.8408     | 46           | 1661.90  | 144.51      | 79           | 4901.68  | 248.19      |
| 14           | 153.9384 | 43.9824     | 47           | 1734.94  | 147.65      | 80           | 5026.56  | 251.33      |
| 15           | 176.7150 | 47.1240     | 48           | 1809.56  | 150.79      | 81           | 5153.00  | 254.48      |
| 16           | 201.0624 | 50.2656     | 49           | 1885.74  | 153.93      | 82           | 5281.02  | 257.62      |
| 17           | 226.9806 | 53.4072     | 50           | 1963.50  | 157.08      | 83           | 5410.62  | 260.76      |
| 18           | 254.4696 | 56.5488     | 51           | 2042.82  | 160.22      | 84           | 5541.78  | 263.90      |
| 19           | 283.5294 | 59.6904     | 52           | 2123.72  | 163.36      | 85           | 5674.51  | 267.04      |
| 20           | 314.1600 | 62.8320     | 53           | 2206.18  | 166.50      | 86           | 5808.81  | 270.18      |
| 21           | 346.3614 | 65.9736     | 54           | 2290.22  | 169.64      | 87           | 5944.69  | 273.33      |
| 22           | 380.1336 | 69.1152     | 55           | 2375.83  | 172.78      | 88           | 6082.13  | 276.47      |
| 23           | 415.4766 | 72.2568     | 56           | 2463.01  | 175.93      | 89           | 6221.15  | 279.61      |
| 24           | 452.3904 | 75.3984     | 57           | 2551.76  | 179.07      | 90           | 6361.74  | 282.75      |
| 25           | 490.8750 | 78.5400     | 58           | 2642.08  | 182.21      | 91           | 6503.89  | 285.89      |
| 26           | 530.9304 | 81.6816     | 59           | 2733.97  | 185.35      | 92           | 6647.62  | 289.03      |
| 27           | 572.5566 | 84.8232     | 60           | 2827.44  | 188.49      | 93           | 6792.92  | 292.17      |
| 28           | 615.7536 | 87.9648     | 61           | 2922.47  | 191.63      | 94           | 6939.79  | 295.32      |
| 29           | 660.5214 | 91.1064     | 62           | 3019.07  | 194.78      | 95           | 7088.23  | 298.46      |
| 30           | 706.8600 | 94.2480     | 63           | 3117.25  | 197.92      | 96           | 7238.24  | 301.60      |
| 31           | 754.7694 | 97.3896     | 64           | 3216.99  | 201.06      | 97           | 7389.82  | 304.74      |
| 32           | 804.2496 | 100.5312    | 65           | 3318.31  | 204.20      | 98           | 7545.98  | 307.87      |
| 33           | 855.3006 | 103.6728    | 66           | 3421.20  | 207.34      | 99           | 7697.70  | 311.01      |



[ X ]

# PATENT APPARATUS

FOR THE PRODUCTION OF

## AIR-LIGHT,

SPECIALY ADAPTED FOR COUNTRY HOUSES, CHURCHES AND CHAPELS, RAILWAY STATIONS, SCHOOLS, AND CONSERVATORIES.

Various attempts have been made, from the days of Mansfield down to the present time, to carburet air so as to obtain light from it, but it has only been within the period dating from the discovery of Petroleum that any advance in this mode of producing artificial light has been made.

Prior to this discovery the difficulty was to produce a spirit sufficiently volatile at comparatively low temperatures to be carried off with air so as to produce a good light when burning.

Petroleum is apparently almost as inexhaustible as coal, and as a spirit of the requisite specific gravity and in sufficient abundance can be obtained, there is now no difficulty in supplying effective apparatus for the production of air light.

Air is the vehicle—the carrier of the hydrocarbon vapour—and acts the part of the wick in a candle or lamp in conveying to the point of combustion the light-giving agent. It is, however, not gas; it is vapour consisting of hydrogen and carbon mechanically taken over by and incorporated with air, by the law of diffusion.

It may be taken as an axiom that as is the rapidity of evaporation, so is the cold; and as is the variation of temperature so is the quality of the light affected, the greater the cold the less the light, and *vice versa*. It therefore becomes necessary to consider the climate of the country in which the apparatus is going to be fixed, in order that special instructions may be given for placing the apparatus in such a position as to be suited to the climate; hence it will be always advisable to state the country for which it is intended when ordering.

Air-light has advantages over gas made from coal for small consumers, in there being less labour required, and in being ready at a moment's notice, while no more air is charged with the light-giving vapour than is required for use at the time, and the lights may be maintained continuously without any gasholder. Another advantage is that the air, as already stated, being the carrier of hydrocarbon vapour, contributes to the support of combustion, and by being taken from the *outside* of the room, less is vitiated *inside* than is the case with any other mode of producing artificial light; for with coal-gas, oil, or candles, each light takes the whole of its air from the room in which it is placed.

Air-light is besides perfectly free from sulphur or ammonia in any form, and though much more is made of the alleged impurities in coal-gas than there is—as a rule—any occasion for; yet the advantages which air-light possesses are such as to weigh most with those who desire a good and pure light conveniently produced, without much reference to cost, when they have to decide between making coal-gas on a small scale, or air light.

The apparatus which the author has devised is automatic, and beyond seeing that it is supplied with gasoline, and the weights wound up to give the motive power to the machinery in the carburetting vessel, nothing more is required to be done. The whole labour connected with the apparatus will not average half an hour a day.

Where possible, it is recommended to have as much spirit at a time as will last the greater part of the year, as it costs much less in quantities of a ton and upwards, than when purchased in smaller lots.

The bulk of the spirit should be kept in a building by itself and away from the premises as far as is convenient, and a pipe led from it for providing a continuous and regular supply to the apparatus.

In fitting up the premises with pipes for conveying the carburetted air to the burners, they should be somewhat larger than for coal gas, and there should be a fall in every direction to the apparatus; but where this is not possible, then receivers should be placed at the depressed positions to receive any condensed fluid which may have deposited in the pipes, though this is of rare occurrence.

Besides the economical production of the carburetted air, it must be properly consumed, and a special burner is absolutely necessary for the purpose of obtaining the greatest amount of light from the least consumption of gasoline.

About three gallons of the spirit will give as much light as 1000 cubic feet of ordinary coal-gas, and the price varies from 1s. to 3s. per gallon, depending upon the quarter of the world in which it is required.

An Air-Light apparatus is undoubtedly convenient for export and for isolated buildings, and it may be used in situations where it would be impossible for a coal-gas works to be erected.

The apparatus can be sent away complete in itself, and needs no skilled mechanic to fix it; the directions for this purpose which accompany each apparatus being amply sufficient for anyone to set it in operation, and also for working it. It is recommended that instead of having one apparatus for the supply of say 200 lights, two should be had for the supply of 100 lights each.

The author undertakes, when required, the fitting up of the interior of buildings with pipes, pendants, brackets, and special air-light burners, at a sum complete for the whole.

|                     |          |         |          |         |          |             |
|---------------------|----------|---------|----------|---------|----------|-------------|
|                     | 5.       | 15      | 25.      | 50.     | 75.      | 100 lights. |
| Prices at St. Neots | £12 10 0 | £20 0 0 | £35 0 0. | £50 0 0 | £75 0 0. | £100 0 0    |

Packing for export, and delivering at any Shipping port in England 5 per cent. on cost.

Larger sizes on application.

GEORGE BOWER, ST. NEOTS, HUNTINGDONSHIRE.

[ Y ]

## GAS AS FUEL AND AS A MOTIVE POWER.

Since the days of Watt the steam engine has been the great motive power of the world, and until some more direct mode of converting heat into power be discovered, it is likely that steam will continue to be the principal means of transferring the energy produced by the combustion of fuel to the work to be done.

Motive power, as produced through the intervention of a steam or other heat engine, is of necessity much less than that which is actually produced by the chemical combination of the fuel with oxygen, or, as is commonly expressed, by its combustion. This loss is so great that, in the best steam engines of the day, not one-tenth part of the possible energy of the fuel is rendered effective. The object of inventors has been, and ever will be, to diminish these losses as far as possible; and they have so far succeeded with regard to the steam engine that it is probable that little more remains to be done. The sources of loss connected with steam power are, chiefly, incomplete combustion, radiation, the waste of heat up the chimney, and the inefficiency of the fluid in the engine. The losses due to the boiler have been greatly diminished by using a fan or steam jet to force air through the fuel; thus doing away with the necessity for a high temperature in the chimney to produce a draught, by heating the feed water with heat that would otherwise be wasted, and by carefully clothing all parts exposed to the cooling influence of the external air. By these and other means we have probably arrived as near to perfection in the ordinary steam boiler as we well can. A suggestion was made some few years ago by M. Lefroy, to generate steam by forcing air through incandescent fuel, under such a pressure that the products of combustion were forced through the water itself, and mingling with the steam were used in the engine in the ordinary way. This was a step in the right direction, but practical difficulties prevented its adoption. The great source of loss, however, is in the engine, and the chief object to bear in mind is, that the efficiency of an engine depends upon the difference between the temperature of receiving and rejecting heat, and that as we increase this difference, so do the results ameliorate. This fact is expressed by the following law:—If  $T$  be the temperature of receiving heat in degrees Fahrenheit, and  $t$  that of rejecting it, corresponding in a steam engine with the boiler and condenser temperatures, then the possible theoretical efficiency of the engine will be approximately expressed by the formula,  $\frac{T-t}{T}$ ; and taking as an example an ordinary condensing engine using steam at 50 lbs. pressure above the atmosphere, it will be seen that the greatest possible efficiency of the fluid in this case is only about 24, and even this can never be obtained in practice for various reasons. It is clear, then, that to increase the efficiency of any heat engine, be it steam, air, or gas, the temperature of the fluid must be as high as possible before, and as low as possible after, performing work; and this loss in temperature must be caused, as far as possible, by the performance of work. Nature has fixed the lower limit of temperature for us, so that only the higher one remains to be dealt with. Here the difference between the steam and gas engine becomes apparent. Steam soon becomes unmanageable, as the pressure increases so rapidly with the temperature; and although Mr. Perkins has employed steam at 500 lbs. per square inch, corresponding with a temperature of 467.5° Fah., the difficulties met with proved too great for its general adoption. In the gas engine matters are very different, as the explosion of a proper mixture of gas and air at the atmospheric pressure would produce theoretically a temperature of 5228° Fah., with a pressure of only 14.6 atmospheres, or 200 lbs. per square inch; and, in practice, a temperature of 2474° Fah. and a pressure of 60 lbs. is actually obtained. When mixed with oxygen alone in proper proportions and exploded, these pressures are much increased, as there is no useless nitrogen to be heated. The following table shows the theoretical pressure of various gases when exploded with oxygen and common air:—

|                          | <i>With Air.</i> | <i>With Oxygen.</i> |
|--------------------------|------------------|---------------------|
| Hydrogen . . . . .       | 12.5 ats.        | 25.6 ats.           |
| Marsh Gas . . . . .      | 14.0 " . . . . . | 37.0 " . . . . .    |
| Olefiant Gas . . . . .   | 15.1 " . . . . . | 42.9 " . . . . .    |
| Propylene Gas . . . . .  | 22.6 " . . . . . | 67.3 " . . . . .    |
| Butylene Gas . . . . .   | 30.2 " . . . . . | 85.8 " . . . . .    |
| Carbonic Oxide . . . . . | 11.7 " . . . . . | 21.8 " . . . . .    |
| Common Gas . . . . .     | 14.6 " . . . . . | 29.2 " . . . . .    |
| Cannel Gas . . . . .     | 18.0 " . . . . . | 38.8 " . . . . .    |

A great number of gas engines have been brought out during late years, one of, if not, the most successful is the Otto Silent Engine. The cycle of operations in this engine is as follows:—Gas and air in proper proportions are drawn into a cylinder by the outstroke of a piston, and then compressed to 30 lbs. per inch during the back stroke; the mixture is then fired, and the pressure rising to 165 lbs. per square inch drives the piston forward, and the products of combustion are expelled by the return stroke. One impulse, therefore, takes place every four strokes or two revolutions. The gas and air are compressed in the first instance so as to produce a high initial pressure at the moment of explosion, rendering a high rate of expansion available by which rejected heat is reduced. The following is a point which the author thinks that inventors should consider: In the steam engine the lowest limit is easily obtained by means of a condenser, and the higher is the one which requires increasing. In the gas engine, as high a temperature as we care about can always be produced, and the chief thing to be sought after is the effective reduction of this temperature to the lower limit by the performance of work. What gas engines may be ultimately made to do may be anticipated from the fact, that engines which reject heat, or allow the products of combustion to escape at a temperature of 1500° Fah., are nevertheless able to give out one horse power per hour for 20 cubic feet of common gas; the coal required for the production of such gas weighing about 4 lbs. This is much better than the performance of most small steam engines, while it must be remembered that one-sixth only of the weight of the coal exists in the gas. It is, therefore, hardly too much to say, that if the coal could be first converted entirely into a gaseous state, and then utilized in a gas engine of an improved type, one half-a-pound of fuel per horse-power per hour would suffice; and besides this economy, an enormous advantage would be gained by the complete abolition of steam boilers, and the dangers which attend them. What form this improved type will ultimately take the Author cannot at present state, but he and Mr. A. S. Bower are working in the direction in which they think that the desired results will be obtained. He expects, however, to be very shortly able to offer gas engines that will certainly not consume more than one-half of the gas required by those of the present day, and he will not confine himself to small powers, being quite confident that gas, as a motive power, is destined to supersede steam in each and every instance, as being safer, cheaper, and far more durable and economical. The day is not far distant when solid combustible matter will be converted into gaseous fuel, and delivered as such, for heat, power, and light; but whether the power will produce the light, or the light be obtained by carburation, remains to be seen.

[ Z ]

## THE PRESERVATION OF IRON AND STEEL FROM RUST.

It is now very generally known that magnetic oxide of iron ( $\text{Fe}_3\text{O}_4$ ) is not affected in any degree by atmospheric influences, and that it is very desirable to be able to coat iron and steel with this peculiar oxide, and so protect them from rust.

Three distinct processes for producing it artificially on iron surfaces are at the present time competing for public favour. One was discovered by Professor Barff, who utilizes the oxygen contained in superheated steam as the agent for producing the necessary protective surface of magnetic oxide. The other two processes are claimed by the author and his son, and respectively depend on the oxygen contained in air and carbonic acid gas ( $\text{CO}_2$ ) to produce the required oxidation.

The air process was the first one brought out by the author. The method of working was exceedingly simple; air was admitted into a retort or chamber the temperature of which was a moderate red heat, and in which the articles to be coated were arranged and the chambers being closed as perfectly as possible, they were allowed to remain until that charge of air had been perfectly deoxidized, when a fresh supply of air was sent in and the process repeated, until a sufficiently thick coating of magnetic oxide had been formed on the iron; or the articles were subjected to the action of a very gentle current of air, carefully regulated according to circumstances. A defect, however, not in the process itself, but in the application of it practically, was very manifest, involving as the process did, the external application of heat to the chamber, which when of large dimensions was costly, inconvenient, and difficult to maintain the articles contained therein of an equable temperature throughout. The next course decided on was to use the products of combustion from a suitable furnace, instead of air alone, or to subject the iron to the oxidizing influence of carbonic acid gas ( $\text{CO}_2$ ).

These experiments led up to the present system of working, which is a careful combination of both the previous methods. The process is as follows:—The articles are heated by the combustion of carbonic oxide ( $\text{CO}$ ) with an excess of air inside the retort or chamber, and the carbonic acid gas ( $\text{CO}_2$ ) so formed together with the excess of air produce the desired film; but if by any chance red oxide of iron ( $\text{Fe}_2\text{O}_3$ ) should be formed it can be immediately reduced to ( $\text{Fe}_3\text{O}_4$ ) by shutting off the supply of air.

The coating next the iron is black while the surface is of a delicate French grey, which for most articles is of itself sufficiently beautiful as to put them in need of no additional decoration; if, however, it be necessary to apply other colours there is the certainty that the pigment will adhere to it, all danger of "lateral" rusting being obviously removed.

The process admits of enormous application. It will in the case of articles of domestic ironmongery supersede the necessity of tinning or enamelling; underground pipes may be subjected to the process, and then before cooling be dipped in the usual way, and thus become practically indestructible either from external or internal agencies. The absolute net cost of the process will be but small, and but for the labour of placing the articles in and withdrawing them from the chambers there would be no more cost in coating one thousand articles than there would be in coating one solid block of the same weight. The process is so penetrating, that the most delicate and intricate designs can be coated as perfectly as the plainest surface, even where it would be almost impossible to galvanize, tin, enamel, or japan or paint them.

Articles were coated in July, 1877, and have been exposed in the open air during the whole of that time, and they are as free from rust as they were when first exposed. Mr. F. J. Evans, M.I.C.E., the Designer and Engineer of the Beckton Gas Works, belonging to the Gas-Light and Coke Company, London, exposed a specimen under very severe conditions in July, 1877, and he testifies that the specimen is as perfect as ever (May, 1879).

It is to be presumed that any process that will extend the applications of iron, or remove objections to its use, will be welcomed by those who know, by experience, how important it is that it should be protected from rust.

"THE GAS TRADE CIRCULAR AND REVIEW," November 1879, contains the following remarks on the above, by Mr. Pelham R. Ogle, M.A., F.C.S.:—

"This is a great invention—the importance of which it is scarcely possible to exaggerate. In the light of the past history of inventions, it is not surprising to find that the development of this important process is not the work of one man. The same end has been accomplished, independently, by entirely different means, by Mr. Frederick S. Barff, Professor of Chemistry to the Royal Academy, and Mr. George Bower, of St. Neots, Hunts. The former gentleman, by passing steam over iron at a temperature of from 500 deg. to 1000 deg. Fah., according to the size and variety of the iron, procures upon the surface an adherent deposit of the magnetic oxide. Mr. Bower passes into the chamber containing the iron a mixture of carbon monoxide and air, the combination of the mixture supplies the heat for the operation, while the resulting carbon dioxide converts the iron superficially into magnetic oxide, carbon and monoxide being produced.

"Magnetic or ferrous-ferric oxide results from the action of either water or carbonic acid upon metallic iron—

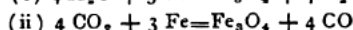
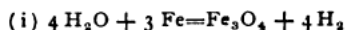

"Mr. George Bower has discovered that when iron is oxidised by air, strictly limited in quantity according to the quantity of iron present, that magnetic oxide is produced—

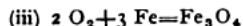

instead of the red oxide ( $\text{Fe}_2\text{O}_3$ ) which would be produced if there were an unlimited supply of oxygen.

"There were thus three ways of superficially converting iron into magnetic oxide, namely, by water, carbonic acid, and air. The former of these methods has been adopted by Professor Barff in his process of protecting iron from rust, the two latter named methods have been adopted by Mr. George Bower for exactly the same purpose.

"The chemical stability of this body and the consequent resistance of decomposition and disintegration, points to it as being a most appropriate protection for iron from the oxidising action of the atmosphere.

"It has accordingly for long been in the minds of practical scientists how a coating of this oxide may be most effectively applied to the surface of iron. Mr. Gossage and Dr. Siemens both, I am told, experimented successfully in this direction. Twelve years ago Mr. Bower, while preparing hydrogen (as the basis of a cheap non-illuminating gas) by the well-known method of M.M. Regnault and Guy Lussac, had his attention drawn to the coherence of the resulting magnetic oxide by the cessation of the decomposition of the steam caused by the iron in use being completely coated by the oxide. He, in fact, then observed that the coat of magnetic oxide shielded iron from the chemical action of water and oxygen.

"The principle of that process, which Professor Barff has now made his own, at once struck him. He followed up the idea with some experiments similar to the subsequent ones of Professor Barff, but he failed to bring it to perfection through the imperfect exclusion of rust. He did not publish his experiments or pursue the investigation. Professor Barff took up the subject in the same direction some five or six years ago while experimenting with Mr. Hugh Smith on different methods for preventing incrustation and corrosion of steam

boilers, and by a series of laborious and patient experiments finally determined a method by which this desirable result may be accomplished. On the publication of Professor Barff's successful results, Mr. Bower conceived the idea that the same results (i.e., effecting a coating of magnetic oxide) might be obtained by the action of air, and this he brought to a satisfactory state of efficiency.

Led on by the difficulty of applying this process to wrought iron and steel, both of which contain less carbon than cast iron, Mr. Bower saw the important share that the carbonic acid (formed by the process) had in the chemical action. Accordingly, he substituted carbonic acid with great advantage, and finally adopted the method suggested by his son, Mr. Anthony Bower, of surrounding the iron with an inflammable mixture of carbonic monoxide and air, by the combustion of which both the material (carbonic acid) and the heat required for the reaction are simultaneously produced in situ.

It may be well to observe, that while the result obtained by Professor Barff and the Messrs. Bower is the same, the methods by which the result is obtained are radically and entirely different and independent. And if one method is superior to the other, either in the perfection of inoxidation, the beauty of appearance, or the economy of the operation, the public will soon discover it for themselves. If one of these processes can rival the other in either of these respects, the public must choose between them, according as they can afford to disregard cost, or sacrifice beauty to utility.

These two methods of protecting iron deserve the especial attention of gas managers. Next in importance of the means of gas production is the preservation of plant—so much of it being underground or in ill-ventilated and damp positions. For new iron work nothing will prove itself so economical in the end as the inoxidating processes of Messrs. Barff and Bower: for that which is already erected recourse must be had to paints and enamels—both much superior to the "cheap and nasty" tar that too often usurps its place, and in the end proves but a sorry protection against that dread enemy of our otherwise almost perfect metal, iron."

Specimens of castings coated by Mr. Bower's process were exhibited at the Royal Cornwall Polytechnic Society's Exhibition, and at the Yorkshire Fine Art and Industrial Exhibition, at both of which medals were awarded for the process.

### NOTES ON IRON AND STEEL.

Cast iron will often last for a long time without rusting, if care be taken not to injure its skin, which is coated with a film of silicate of the protoxide of iron, produced by the action of the sand of the mould on the iron. Chilled surfaces of castings are without this protection, and therefore rust more rapidly. The corrosion of iron is more rapid when partly wet and partly dry than when wholly immersed in water or wholly exposed to the air. It is also accelerated by impurities in water, and especially by the presence of decomposing organic matter, or of free acids. It is also accelerated by the contact of the iron with any metal which is electro-negative relatively to the iron, or in other words, has less affinity for oxygen than the other; the contact of the former makes the latter oxidate more rapidly. In general, hard and crystalline iron is less oxidable than ductile and fibrous iron.

Cast iron and steel decompose rapidly in warm or impure sea-water.

Pieces of iron which are kept constantly in a state of vibration oxidate less rapidly than those which are at rest; for example, the rails of a railway on which a constant traffic runs rust much more slowly than those on which there is little or no traffic.—MALLETT.

The quality of pig iron varies according to the purposes for which it is intended, and not only depend upon the quality of the ore, but also upon that of the fuel. The principal division is into foundry-iron and forge iron, the former being used for castings, the latter for conversion into malleable iron.

Foundry-iron is divided into three qualities, differing in the amount of carbon combined, the fluidity when melted, and the hardness when cooled.

In judging of the quality of cast iron the following will be serviceable:—

| <i>Nature of Fracture.</i>                         | <i>Description of Iron.</i> |
|----------------------------------------------------|-----------------------------|
| Lustreless, and of dark colour . . . . .           | Friable and weak            |
| Uniform grey, with high metallic lustre . . . . .  | Tough                       |
| Lightish-grey, with high metallic lustre . . . . . | Hard stiff iron             |
| Light grey, without lustre . . . . .               | Hard and brittle            |
| Very light grey, with radiating crystals . . . . . | Extremely hard and brittle. |

Nitric acid will produce a black spot on steel; the darker the spot the harder the steel. Iron, on the contrary, remains bright if touched with nitric acid.

Good steel in its soft state has a curved fracture and a uniform grey lustre; in its hard state a dull, silvery, uniform white. Cracks, threads, or sparkling particles denote bad quality.

Good steel will not bear a white heat without falling to pieces, and will crumble under the hammer at a "bright" red heat, while at a middling heat it may be drawn out under the hammer to a fine point. Care should be taken that before attempting to draw it out to a point the fracture is not concave, and should it be so the end should be filed to an obtuse point before operating. Steel should be drawn out to a fine point and plunged into cold water; the fractured point should scratch glass. To test its toughness, place a fragment on a block of cast iron; if good, it may be driven by the blow of a hammer into the cast iron, if poor, it will crush under the blow.—*Scientific American*.

A soft tough iron, if broken gradually, gives long silky fibres of leaden-grey hue, which twist together and cohere before breaking.

A medium even grain with fibres, denotes good iron. Badly refined iron gives a short blackish fibre on fracture. A very fine grain denotes hard steely iron, likely to be cold, short, and hard.

Coarse grain with bright crystallized fracture or discoloured spots denotes cold-short, brittle iron, which works easily when heated and welds well. Cracks in the edge of a bar are indications of hot-short iron. Good iron is readily heated, is soft under the hammer, and throws out few sparks.—*MOLESWORTH'S Pocket Book*.

## ELECTRIC LIGHTING.

While the last pages of this BOOK OF REFERENCE are passing through the press, renewed statements have arrived from America that Mr. Edison has solved the problem of Electric Lighting in its universal application. Whether this shall prove to be really the case will be seen in good time, but continued agitation in the lighting interests is caused by these repeated announcements, more than by the real progress of the Electric light itself. However, this real progress is such that it is evident that Electricity must now be considered as one of the important sources of light, and one which in the near future will play an important part, whether it in any degree replaces the more familiar illuminants, or whether it simply adds to them a new and more powerful source of light adapted to purposes for which they are only partially available. Therefore, those who are interested in the production of light must prepare to avail themselves of the new agent, and acquaint themselves with the conditions of its production and utilization.

The obtaining of light by means of electricity involves two distinct processes, each of which has its own difficulties—the production of the Electric current itself, and the obtaining light by means of that current. So far as actual progress has yet been made, it is in the first of these that recent advances have tended to make Electric lighting practicable. The actual lamps and means of producing light, though much improved in many details, are even now but little different from those employed for special purposes for many years; but the introduction of the Dynamo-Electric Machine has provided a means of generating the required large currents at a very small cost compared with the only previously available source—the Galvanic Battery. A great amount of attention has been given to these machines, and many forms are now before the public, such as the Gramme, the Siemens, the Wallace, and the Brush, each of which has its merits. Others have been working in the same direction, and undoubtedly further improvements will be made in simplifying and cheapening the machines, and in obtaining still better results from them.

Believing as the author does that the mechanical production of light will fairly establish itself as one of the systems of artificial lighting—though he by no means believes that it will supplant coal gas, but rather act as a spur to its further development in directions for which it is eminently fitted—he has not hesitated to seize an opportunity which presented itself of arranging terms with one of the most eminent workers in this field—Mr. Sprague—a well-known electrical engineer and author, who, in consequence of his experience in this department of electricity, combined with knowledge of Gas manufacture and lighting, was specially sent over to Paris in 1878, by some of the large companies, to inquire into the processes of the Electric lighting introduced there. Mr. Sprague has been working at the subject from that time, and, after carefully studying all that has been done, has invented and patented a number of improvements, resulting in a form of machine which can be trusted to the hands of ordinarily skilled workmen, without that liability to injury to which all other machines are subject. In factories and other works and buildings where motive-power already exists, and where skilled workmen are at hand to attend to the machines, the value and economy of the Electric light will be the most apparent, especially where the arrangements are such as to permit a few powerful lights to be so placed as to give effective illumination, and to replace a number of other smaller lights distributed in all directions.

The manufacture of these machines is not yet so far advanced as to enable the author to furnish particulars and prices, but in a short time he will be prepared to add this branch of lighting to his operations, and to undertake the supply and erection of all the necessary apparatus for public and private lighting.

# SELECTED LIST OF GAS WORKS

SUPPLIED AND ERECTED BY

## GEORGE BOWER,

*Gas and Water Engineer and Contractor, St. Neots, Hunts.*

The selected list of Gas and Water Works herewith given, is exclusive of a great number either erected complete, or the plant supplied to Agents and Engineers, the destinations of which it would not be proper to give, and of minor alterations and additions to existing Works.

### *Cities, Towns, and Villages.*

|                           |                        |                             |                                 |                            |                                 |
|---------------------------|------------------------|-----------------------------|---------------------------------|----------------------------|---------------------------------|
| Amlwich . . . . .         | Isle of Anglesea       | Haverhill . . . . .         | Suffolk                         | Rickmansworth              | Herts ( <i>remodelled</i> )     |
| Amptill . . . . .         | Bedfordshire           | Higham Ferrers . . . . .    | Northamptonshire                | Rio Grande do Sul          | Brazil                          |
| Barkway . . . . .         | Hertfordshire          | Hirwain . . . . .           | Glamorganshire                  | Risca and Ponty-           | Monmouthshire                   |
| Barrow . . . . .          | Lincolnshire           | Horbling . . . . .          | Lincolnshire                    | mister . . . . .           |                                 |
| Beaufort . . . . .        | Breconshire            | Invercargill . . . . .      | New Zealand                     | Rockingham . . . . .       | Northamptonshire                |
| Belgrano . . . . .        | Argentine Confede-     | Irthingborough . . . . .    | Northamptonshire                | Roux . . . . .             | Belgium                         |
|                           | ration                 | Kelvedon . . . . .          | Essex                           | Saffron Walden . . . . .   | Essex                           |
| Biggleswade . . . . .     | Bedfordshire           | Kempstone . . . . .         | Bedfordshire                    | Sandy . . . . .            | Bedfordshire                    |
| Billingboro' . . . . .    | Lincolnshire           | Ketton . . . . .            | Rutland                         | San Sebastian . . . . .    | Spain                           |
| Bishop's Castle . . . . . | Shropshire             | Kimbolton . . . . .         | Huntingdonshire                 | Schagen . . . . .          | Holland                         |
| Bolsover . . . . .        | Derbyshire             | King's Cliffe . . . . .     | Northamptonshire                | Shanklin . . . . .         | Isle of Wight                   |
| Bourne . . . . .          | Lincolnshire           | Kirtou in Lindsey . . . . . | Lincolnshire                    | Skibbereen . . . . .       | Ireland                         |
| Buckfastleigh . . . . .   | Devonshire             | Leyburn . . . . .           | Yorkshire ( <i>remodelled</i> ) | Somerby . . . . .          | Leicestershire                  |
| Buckingham . . . . .      | ( <i>remodelled</i> )  | Llandilo-vawr . . . . .     | Cardiganshire                   | Spa . . . . .              | Belgium                         |
| Buenos Ayres . . . . .    | Two Works, one for     | Llantrissant . . . . .      | Glamorganshire                  | St. Blazey . . . . .       | Cornwall                        |
|                           | the Argentine Gas      | Littlehampton . . . . .     | Sussex                          | St. Ives . . . . .         | Hunts ( <i>remodelled</i> )     |
|                           | Co., the other for the | Littleport . . . . .        | Cambridgeshire                  | St. Ives . . . . .         | Cornwall                        |
|                           | Buenos Ayres Gas Co.   | Logrono . . . . .           | Spain                           | St. John's . . . . .       | Porto Rico                      |
|                           | Limited                | Looe . . . . .              | Cornwall                        | St. Neots . . . . .        | Hunts ( <i>remodelled</i> )     |
| Burford . . . . .         | Oxfordshire            | Lyttleton . . . . .         | New Zealand                     | St. Heliers . . . . .      | Jersey ( <i>Water Works</i> )   |
| Caerleon . . . . .        | Monmouthshire          | Maranhã . . . . .           | Brazil ( <i>Water Works</i> )   | Stevenage . . . . .        | Hertfordshire                   |
| Caistor . . . . .         | Lincolnshire           | March . . . . .             | Cambridgeshire ( <i>re-</i>     | Stoney Stratford . . . . . | Bucks ( <i>remodelled</i> )     |
| Casale . . . . .          | Italy                  |                             | <i>modelled</i> )               | Sudbury . . . . .          | Suffolk ( <i>Water Works</i> )  |
| Charing . . . . .         | Kent                   | Middleham . . . . .         | Yorkshire                       | Sutton Valance . . . . .   | Kent                            |
| Chertsey . . . . .        | Surrey                 | Milverton . . . . .         | Somerset                        | Syston . . . . .           | Leicestershire                  |
| Childwall . . . . .       | Lancashire             | Minehead . . . . .          | Somerset                        | Swineshead . . . . .       | Lincolnshire                    |
| Chimay . . . . .          | Belgium                | Mountsorrell . . . . .      | Leicestershire                  | Thorney . . . . .          | Cambridgeshire                  |
| Cleethorpes . . . . .     | Lincolnshire           | Navenby . . . . .           | Lincolnshire                    | Truro . . . . .            | Cornwall ( <i>Water</i>         |
| Christchurch . . . . .    | New Zealand            | Nayland . . . . .           | Suffolk                         |                            | <i>Works</i> )                  |
| Coalville . . . . .       | Leicestershire         | Nettlebed . . . . .         | Oxfordshire                     | Tunis, City of . . . . .   | Tunis                           |
| Collingham . . . . .      | Nottinghamshire        | Newport Pagnell . . . . .   | Bucks ( <i>remodelled</i> )     | Turvey . . . . .           | Bedfordshire                    |
| Colombo . . . . .         | Ceylon                 | Newport . . . . .           | Essex                           | Tver . . . . .             | Russia <i>Gas and Water</i>     |
| Cottingham . . . . .      | Yorkshire              | Oakhã . . . . .             | Rutland                         |                            | <i>Works &amp; Public Baths</i> |
| Cranleigh . . . . .       | Surrey                 | Olinda . . . . .            | Brazil                          | Vittoria . . . . .         | Spain                           |
| Crickhowel . . . . .      | Breconshire            | Pangbourne . . . . .        | Berkshire                       | Voronege . . . . .         | Russia ( <i>Water Works</i> )   |
| Cromer . . . . .          | Norfolk                | Patrington . . . . .        | Yorkshire                       | Wainfleet . . . . .        | Lincolnshire                    |
| Cuidad Real . . . . .     | Spain                  | Pelotas . . . . .           | Brazil                          | Wantage . . . . .          | Berks ( <i>remodelled</i> )     |
| Dokkum . . . . .          | The Netherlands        | Porte Alegre . . . . .      | Brazil                          | Waterbeach . . . . .       | Cambridgeshire                  |
| Donnington . . . . .      | Lincolnshire           | Ponce . . . . .             | Porto Rico                      | Wellingborough . . . . .   | Northamptonshire ( <i>re-</i>   |
| Dragten . . . . .         | The Netherlands        | Port Elizabeth . . . . .    | Natal                           |                            | <i>modelled</i> )               |
| Easton . . . . .          | Northamptonshire       | Potton . . . . .            | Bedfordshire                    | Wellingore . . . . .       | Lincolnshire                    |
| Ebbw Vale . . . . .       | Monmouthshire          | Purmerende . . . . .        | The Netherlands                 | West Houghton . . . . .    | Lancashire                      |
| Eu . . . . .              | France                 | Quorndon . . . . .          | Leicestershire                  | Whittlesea . . . . .       | Cambridgeshire ( <i>re-</i>     |
| Evesham . . . . .         | Worcestershire         | Raunds . . . . .            | Northamptonshire                |                            | <i>modelled</i> )               |
| Folkingham . . . . .      | Lincolnshire           | Redbourne . . . . .         | Hertfordshire                   | Whitwick . . . . .         | Leicestershire                  |
| Gefle . . . . .           | Sweden                 | Red Hill . . . . .          | Surrey                          | Wigston . . . . .          | Leicestershire                  |
| Harlingen . . . . .       | The Netherlands        | Repton . . . . .            | Derbyshire                      | Wincanton . . . . .        | Somersetshire                   |
| Hatfield . . . . .        | Hertfordshire          | Rhyader . . . . .           | Radnorshire                     | Witney . . . . .           | Oxon ( <i>remodelled</i> )      |

### *Palaces, Mansions, &c.*

|                                                    |                                    |                                             |                            |
|----------------------------------------------------|------------------------------------|---------------------------------------------|----------------------------|
| His Majesty the Shah of Persia . . . . .           | Teheran                            | His Grace the Duke of Marlborough . . . . . | Blenheim Palace, Woodstock |
| His Highness the Viceroy of Egypt . . . . .        | Alexandria                         | His Grace the Duke of Newcastle . . . . .   | Clumber Park, Worksop      |
| His Highness the Prince Putbus of Putbus . . . . . | Isle of Rugen, Prussia             | Her Grace the Dowager Duchess of . . . . .  | Stanwick Hall, Darlington  |
| His Grace the Duke of Buckingham . . . . .         | Wootton House, Aylesbury . . . . . |                                             |                            |
| and Chandos . . . . .                              | and                                | The Most Hon. the Marquis of . . . . .      | Easthampstead Park, Wo-    |
|                                                    | Stowe Palace, Buckingham . . . . . | Downshire . . . . .                         | kingham                    |
| His Grace "the Duke of Grafton" . . . . .          | Wakefield Lodge, near . . . . .    | The Most Hon. the Marquis of . . . . .      | Burghley House, Stamford   |
|                                                    | Stoney Stratford . . . . .         | Exeter . . . . .                            |                            |

PALACES, MANSIONS, &c.—*continued.*

|                                                               |                                  |                             |                                             |
|---------------------------------------------------------------|----------------------------------|-----------------------------|---------------------------------------------|
| The Most Hon. the Marquis of Salisbury                        | Childwall, near Liverpool        | Gwyn, Howell, Esq., M. P.   | Dyffryn House, Neath                        |
| The Right Hon. the Earl of Carysfort                          | Elton Hall, near Oundle          | Haigh, G. H., Esq.          | Grainsby Hall, Louth                        |
| The Right Hon. the Earl of Cawdor                             | Stackpole Court, Pembroke        | Hanbury, Mrs. R. C.         | Bidwell Park, Hertford                      |
| The Right Hon. the Earl of Hopetoun                           | Papillon Hall, Market Harborough | Harter, Rev. G. C.          | Cranfield Court, Newport Pagnall            |
| The Right Hon. the Earl of Macclesfield                       | Sherborn Castle, Tetworth        | Holford, R. S., Esq., M.P.  | Westonbirt, Tetbury                         |
| The Right Hon. the Earl of Roden                              | Tollymore Park, Ireland          | Holland, W., Esq.           | Maenturog, Caernarvon                       |
| The Right Hon. the Earl of Stamford and Warrington            | Enville Hall, Stourbridge        | Ince, Townshend, Esq.       | Christleton, Cheshire                       |
| The Right Hon. the Earl of Westmoreland                       | Apethorpe Park, Wansford         | Johnson and Jeans, Messrs.  | London, for Courteen Hall, Northamptonshire |
| The Right Hon. the Earl of Zetland                            | Aske Hall, Richmond, Yorkshire   | Jones, Joseph, Esq.         | Abberly Hall, Stourport                     |
| Bridport, Major-General Lord Waveney, The Right Hon. Lord     | Cricket St. Thomas, Chard        | Jones, J. J., Esq.          | Pensax Court, Tenbury                       |
|                                                               | Flixton Hall, Bungay, Suffolk    | Joseph, Thomas, Esq.        | Treherbert, Pontypridd                      |
| Lord Berners, The Right Hon. Gore Booth, Sir R., Bart., M. P. | Keythorpe Hall, Leicester        | Lake, G., Esq.              | Bushey, near Watford                        |
| Cholmeley, Sir Montague, Bart., M.P.                          | Lissadel, Sligo, Ireland         | Lansdorf, The Count         | St. Petersburg, Russia                      |
| Thorold, Sir John, Bart., M. P.                               | Easton Hall, near Grantham       | Leigh, J. S., Esq.          | Hoo Park, Luton                             |
| Allsope, Henry, Esq.                                          | Syston Hall, Grantham            | Longman, Thomas, Esq.       | Farnborough Hill, Hants                     |
| Anderson, Thomas D., Esq.                                     | Hindlip Hall, near Worcester     | Miller, Thomas H.           | Poulton le Fylde                            |
| Ames, Colonel Lionel                                          | Waveley Abbey, Farnham           | Montgomerie, Molyneux, Esq. | Garboldsham Manor, East Harling             |
| Ashby, Captain Ashby                                          | The Hyde, St. Albans             | Munday, E. M., Esq.         | Shipley Hall, Derby                         |
| Benyon, R., Esq., M. P.                                       | Nazeby Woolleys, Northants       | Newton, G. O., Esq.         | Croxtan Park, Cambridgeshire                |
| Benyon, Rev. E. R.                                            | Englefield, Reading              | Nostitz, The Count          | Odeesa, Russia                              |
|                                                               | Culford Hall, Bury St. Edmunds   | Owens and Co., Messrs.      | London, for Mansion near Wallingford        |
| Bickford, Major                                               | Tucking Mill, Cornwall           | Pearce, J. D. M., Esq.      | Crauford College, Maidenhead                |
| Bolckow, J., Esq., M. P.                                      | Marton Hall, Middleboro'         | Paxton, W., Esq.            | Little Gaddesden, near Great Berkhamstead   |
| Brown, W. S., Esq.                                            | Ayot St. Lawrence, Herts         | Petre, The Hon. H.          | Springfield Hall, Chelmsford                |
| Buckworth, F. R., Esq.                                        | Cockley Clay Hall, Swaffham      | Phillips, C., Esq.          | Shillingthorpe Hall, Stamford               |
| Crammell, Charles, Esq.                                       | Norton Hall, Sheffield           | Pilgrim, C., Esq.           | Akeley Wood, Buckingham                     |
| Coleman, J., Esq.                                             | Stoke Park, Windsor              | Reynolds, E., Esq.          | Paxton Hall, St. Neots                      |
| De Winton, A.                                                 | Maeslwich Castle, Radnorshire    | Roden, R. B., Esq.          | Ponty-moil, Pontypool                       |
|                                                               | Wareasley Park, Hunts            | Sandbach, H. R., Esq.       | Hafodunos House, Llanrwst                   |
| Dunccombe, Colonel, The Hon. O., M. P.                        | Inglewood House, Kintbury        | Seager, J., Esq.            | Constantinople                              |
| Dunn, Mrs., General                                           | Eyton Hall, Salop                | Stanley, S., Esq.           | Longstow Hall, Cambs                        |
| Eyton, Captain                                                | Haviland Hall, Norwich           | Stanley, J. M., Esq.        | Wickham Market                              |
| Fellowes, E., Esq., M. P.                                     | Ham Place, Arundel, Sussex       | Stevens, Rev. S.            | St. Andrew's College, Bradfield, Reading    |
| Fletcher, Sir Henry                                           | Glengorm, Tobemorey, N. B.       | Staughton, F. A., Esq.      | Owlpen House, Dursley, Gloucestershire      |
| Forsyth, Mrs.                                                 | Apley Hall, Bridgnorth           | Tabor, Rev. R. S.           | Cheam, Surrey                               |
| Foster, W. O., Esq.                                           | Abernant House, Aberdare         | Talbot, C. R. M., Esq.      | Margam Park, Taibach                        |
| Fothergill, R., Esq.                                          | Fornham Park, Bury St. Edmunds   | Vaughan, J., Esq.           | Middlesboro' on Tees                        |
| Gillstrap, W. H., Esq.                                        |                                  | Vansittart, S. H., Esq.     | Bisham Abbey, Maidenhead                    |
|                                                               |                                  | Watson, G. L., Esq.         | Rockingham Castle, Northants                |
|                                                               |                                  | Wilson, W. M., Esq.         | Stowlangtoft Hall, Bury St. Edmunds         |

*Factories, Railway and Military Stations, &c.*

|                           |                           |                                                       |                                   |                |                                  |
|---------------------------|---------------------------|-------------------------------------------------------|-----------------------------------|----------------|----------------------------------|
| British Government        | Harbour Works             | Cape of Good Hope                                     | Bolckow and Vaughan               | Iron Works     | Middlesbro'                      |
| "                         | Military Station          | Rawal Pindee, India                                   | "                                 | "              | Eston, near Stockton             |
| "                         | "                         | Allahabad, India                                      | Bellefroid, M.                    | "              | Liege, Belgium                   |
| "                         | "                         | Fort St. George, Madras, India ( <i>re-modelled</i> ) | Billing and Son                   | Paper Mills    | Newport, Salop                   |
| French Government         | Tunnel under Mont Cenis   | France                                                | Blount and Co.                    | "              | Paris                            |
| Italian Government        | Tunnel under Mont Cenis   | Italy                                                 | Boughton, Smith, and Co.          | Tin Works      | Pontardulais, near Swansea       |
| "                         | Six Railway Stations      | Italy                                                 | Brothers of Charity, The Order of | The Monastery  | Antwerp                          |
| Japanese Government       | Mining Department         |                                                       | Brown, H., Esq.                   | Silk Factory   | Tewkesbury                       |
| Abersychan Iron Co.       | Iron Works                | Monmouthshire                                         | Brown, B., Esq.                   | Paper Mills    | Tonbridge                        |
| Allen, J., Esq.           | Paper Mills               | Ivy Bringe                                            | Brown, Sir John and Co., Limited  | "              | Sheffield                        |
| Arnold, H. T., Esq.       | "                         | Swansea                                               | Brunner and Mond                  | "              | Northwich                        |
| Ashford Station and Works | South Eastern Railway Co. | Ashford                                               | Brymbo Iron Company               | Iron Works     | Wrexham                          |
| Barrow, R., Esq.          | Three Coal Pits           | Staveley                                              | Burntiswood Asylum                | Asylum         | Burntiswood, near Lichfield      |
| Bayer and Co.             | "                         | Sourabaya, Java                                       | Castelli, M.                      | Cotton Factory | Serravalle, Italy                |
| Bengal Mills Company      | "                         | London, for India                                     | Chludow, A. and G.                | "              | Liverpool (two works for Russia) |
| Benoit Freres             | "                         | Poullignac-Croisie, France                            | Cocker and Sons                   | Needle Factory | Hathersage, Sheffield            |
| Berrywood Asylum          | "                         | Northampton                                           | Combe and Son                     | Paper Mills    | Wolvercot, Oxford                |
|                           |                           |                                                       | Contoni, M. Eugine                | Cotton Mills   | Castellana, Milan                |
|                           |                           |                                                       | County Asylum                     | Asylum         | Hereford                         |

FACTORIES, RAILWAY AND MILITARY STATIONS, &c.—*continued.*

|                                         |                                  |                                     |                                        |                                                    |                                               |
|-----------------------------------------|----------------------------------|-------------------------------------|----------------------------------------|----------------------------------------------------|-----------------------------------------------|
| Cowan Patents Company                   |                                  | Garston                             | Palmer's Iron and Ship Building Co.    | Iron and Ship Building Works                       | Jarrow, near New castle-on-Tyne               |
| Darenth Asylum                          | Asylum                           | Dartford                            | Parbury and Co.                        | Several Works                                      | London, for Australia                         |
| De Bergue, C., Esq.                     | For Export                       | Manchester and London               | Parke, Pittar and Co.                  | For Export                                         | London                                        |
| De Bergue and Co.                       | Iron Bridge Works                | Llandaff                            | Parker, J. E.                          | For Chassepôt Factory                              | Placencia, Spain                              |
| Dunn, A., Esq.                          | Peat Charcoal Works              | Near Neath                          | Partridge and Jones                    | Colliery                                           | Varteg, Monmouthshire                         |
| Ebbw Vale Company                       | Iron Works                       | Monmouthshire (two works)           | Petchell and Company                   | For Export                                         | Middlesborough - on - Tees                    |
| Elliott Patent Sheating Company         | Metal Works                      | Birmingham                          | Phillips, — Esq.                       | Refreshment Rooms                                  | Swindon                                       |
| Evans, Evan, Esq.                       | Pleasure Gardens                 | Near Neath                          | Pontypool Iron Co.                     | Iron Works                                         | Pontypool                                     |
| Evans, J., Esq.                         |                                  | Colchester                          | Poolman, J., Esq.                      | Sugar Works                                        | Melbourne, Australia                          |
| Eives and Macey                         | Paper Mills                      | Maidstone                           | Porter, J. T. B. and Co.               | A large number of Works both complete and in parts | Lincoln                                       |
| Fairley, F., Esq.                       | For Export                       | London                              | Porter, James, Esq.                    |                                                    | Pekin                                         |
| Ferneden, J. L., Esq.                   |                                  | Haven-Gonda, Holland                | Poteloff, N. P., Esq.                  | Iron Works                                         | St. Petersburg                                |
| Fogg, R., Esq.                          | Paper Mills                      | Cairo, for H. H. The Pasha of Egypt | Potter, Addison, Esq.                  | Firebrick Works                                    | Willington Quay, near Newcastle-on-Tyne       |
| Freiwith, O., Esq.                      |                                  | Moscow (four Works)                 | Rees, J., Esq.                         |                                                    | Lettyshinkin, Aberdare                        |
| Great Indian Peninsular Railway Company | Railway Station                  | India                               | Ransomes, Sims, and Head               | Colliery                                           | Ipswich, for Egypt                            |
| Great Northern Railway Company          | "                                | St. Neots                           | Richards, W. A.                        |                                                    | 9, Walbrook, London, for W. A. Fletcher, Esq. |
| Great Eastern Railway Company           | "                                | Essendine                           | Rignon and Company                     |                                                    | Savigliano, Italy                             |
| " " "                                   | "                                | Audley End                          | Roca, Don José                         |                                                    | Barcelona, Spain                              |
| " " "                                   | "                                | Low Layton                          | Royal School of Mines                  |                                                    | Stuttgart, Wurtemberg                         |
| Great Northern Boiler Company           | Boiler Works                     | Marks Tey Newark                    | Rosser, Thomas                         | Several Works                                      | Nantes, France                                |
| Gilleshoff, H. N., Esq.                 |                                  | St. Petersburg                      | Robins                                 | Cement Works                                       | Northfleet                                    |
| Goldsmith, J. and H.                    |                                  | Bury St. Edmunds                    | Russell, J., and Sons                  | For Export                                         | Wednesbury                                    |
| Gordon, J., Esq.                        | For Export                       | London                              | Russian Spinning Co.                   |                                                    | St. Petersburg                                |
| Hall, J. and Co.                        | Firebrick Works                  | Stourbridge                         | Sampson Cotton Spinning Company        |                                                    | St. Petersburg                                |
| Hants County Prison                     |                                  | Winchester                          | Saunders, Thomas, Esq.                 | Paper Mills                                        | Dartford                                      |
| Hague Authorities                       | Hospital                         | The Hague, Holland                  | Shangshieff, M., Esq.                  |                                                    | St. Petersburg                                |
| Harbottle, J., Esq.                     | For Export                       | London                              | Schippoff and Company                  |                                                    | Moscow                                        |
| Harrison Ainslie, and Company           | Iron Works                       | Lyndal, Lancashire                  | Shropshire Union Railway and Canal Co. | Ellesmere Port                                     | Cheshire                                      |
| Harle and Son                           | For Export                       | Newcastle                           | Shute, Thomas, Esq.                    | Silk Mills                                         | Watford                                       |
| Hepburn and Sons                        | Tannery                          | Dartford                            | Smith and Sons                         | Paper Mills                                        | Watford                                       |
| Hill and Butt                           | Iron Works                       | Oakfield, near Newport              | Smith, G. L., Birmingham               | Chassepôt Rifle Factory                            | Spain                                         |
| Howard, Henry, Esq.                     | Tube Works                       | Old Hill, Dudley                    | Smith, M.                              |                                                    | Yokohama, Japan                               |
| Hughes, H., Esq.                        | Engine Works                     | Loughborough                        | Stephens, G., Esq.                     | Courier Office                                     | Brisbane, Australia                           |
| Hunter, W., Esq.                        | for Vassilli Ostroff Cotton Mill | St. Petersburg                      | Stears, T. W., and Co.                 | Several Works                                      | Hull                                          |
| Jenkins, G., Esq.                       |                                  | Valparaiso                          | Sydney Sugar Co.                       |                                                    | Sydney, Australia                             |
| Jones and Son                           | For Export                       | Bow Street, London                  | Thompson and Co.                       | Sail Cloth Factory                                 | Fordingbridge, Hants                          |
| Keyser, J., Esq.                        | Several Works                    | Amsterdam                           | Towgood Brothers                       | Paper Mills                                        | St. Neots                                     |
| Keyser and Swertz                       | Oil-Cake Mill                    | Amsterdam                           | Towgood, E., Esq.                      | "                                                  | Sawston, Cambridge-shire                      |
| Knight, Bevan, and Sturge               | Cement Works                     | Northfleet                          | Towgood, A., Esq.                      |                                                    | Helpstone                                     |
| Lange, W. H., and Co.                   | Flour Mills                      | Altona, Denmark                     | Taylor and Robinson                    | Woollen Mills                                      | Rastrick, near Huddersfield                   |
| Lansdorf, Count                         | Spinning Mills                   | Okhta, St. Petersburg               | Theatre Royal                          |                                                    | Messina, Sicily                               |
| Leach, Flower, and Co.                  |                                  | Neath                               | Third Middlesex Asylum                 |                                                    | Banstead                                      |
| Lotz, M.                                |                                  | Savenay, France                     | Tidcombe and Son                       | For Export                                         | Watford                                       |
| Ledeboer, J., Esq.                      |                                  | Macassar, Borneo                    | Treschow, C., Esq.                     |                                                    | Lorwig, Norway                                |
| Lewis, W., Esq.                         | Needle Factory                   | Redditch                            | Tudela and Bilbao Railway Company      | Railway Station                                    | Bilbao, Spain                                 |
| Liboutin, D. M.                         |                                  | Roubaix, France                     | Tzarskoe-Selo Railway Company          | Railway Station                                    | St. Petersburg                                |
| Mancardi, S., Esq.                      | Silk Factory                     | Turin                               | Vandenberg and Co.                     |                                                    | Amsterdam                                     |
| Martin, S. G.                           | Several Gas Works                | St. Petersburg                      | Vasconcellos, J. S. de                 | Works for Brazil                                   | Liverpool                                     |
| Maschwitz, C., Jun.                     |                                  | Birmingham (two Works for Russia)   | Vassier and Co.                        | Marnay par Azay le Rideau, Indre et Loire          | France                                        |
| Mason and Elkington                     | Copper Works                     | Pembrey, Llanelly                   | Victoria Sugar Co.                     |                                                    | Melbourne, Australia                          |
| Mathews and Company                     |                                  | Valencia, Spain                     | Vipond and Company.                    | Colliery                                           | Varteg Hill, near Pontypool                   |
| Menaieff and Company                    | Cotton Mills                     | St. Petersburg                      | Wagenmann and Seybell                  |                                                    | Vienna                                        |
| Metallic Works Co.                      |                                  | St. Petersburg                      | Whalley and Hardman                    | Cotton Mills                                       | Kirkham, near Preston                         |
| Middlesex Magistrates                   | Industrial School                | Feltham                             | Wells, J. and G., Limited              |                                                    | Eckington, Chesterfield                       |
| Midland Railway Co.                     | Railway Station                  | Wellingborough                      | West and Son                           | Iron Works                                         | St. Blazey, Cornwall                          |
| Milne, H. B., Esq.                      | Two "Works"                      | Toton                               | Whitehouse, David, Esq.                | Iron and Tin Works                                 | Abercarne, Monmouthshire                      |
| Monasterio de Nostra Signora            | Convent                          | Gefle, Sweden                       | Williams and Company                   | Tin Works                                          | Aberdulais, Neath                             |
| Morton and Company                      | Several Works, Export            | Bilbao, Spain                       | Ybarra and Company                     | Iron Works                                         | Bilbao, Spain                                 |
| Moscow Sugar Company                    | Sugar Works                      | Moscow                              | Zyphen and Company                     | Engineering Factory                                | Cologne                                       |
| Müller and Linck                        |                                  | Stuttgart, Wurtemberg               |                                        |                                                    |                                               |
| National Silk Spinning Company          |                                  | Novaro, Italy                       |                                        |                                                    |                                               |
| Newstead Colliery Co.                   |                                  | Near Nottingham                     |                                        |                                                    |                                               |
| Neville, R., Esq.                       | Iron Works                       | Wern, Llanelly                      |                                        |                                                    |                                               |
| New Passage Hotel Co.                   | Hotel                            | Near Bristol                        |                                        |                                                    |                                               |
| Ogereau, Frères                         |                                  | Nantes                              |                                        |                                                    |                                               |



GEORGE BOWER,  
Gas and Water Engineer, St. Neots, Hunts.

[TELEGRAPHIC ADDRESS,  
BOWER, ST. NEOTS.]

TELEGRAPHIC CODE.

The principal object in coupling the COMPANION with the BOOK OF REFERENCE is to enable Engineers and others resident abroad, who may require either a complete manufacturing plant or some portion of it, to estimate the cost, and to send the order itself at once instead of waiting months in making the inquiry.

To facilitate still further the ordering of plant and material in cases where time is of great importance, a Telegraphic Code of Words is appended for a few leading sentences, to which the Apparatus desired only requires to be added.

A specimen is given below of an imaginary telegram from abroad for an apparatus for a town with about 5,000 inhabitants.

For general guidance as to what will be required, refer to "Observations on the Selection of the Manufacturing Plant," etc., page 149, from which it will be gathered that a manufacturing plant, capable of supplying five million cubic feet of gas per annum, will be sufficient. Allowing a margin, it will be found that No. 8 Apparatus, Specification B, describes an apparatus which will be amply large enough.

To order the apparatus and to make the order sufficiently comprehensive, one word and a figure only are necessary, thus:—

AGATE 8. NOVA.

the last word referring to the Bank (National Bank of New Zealand) through which payment will be made.

TELEGRAPH CODE.

*Code Word.*  
ACTION . . . Send out by first opportunity, a complete plant as under A. Specifications of the size indicated by the number added to the Code word for this sentence.—Payment will be made by the Firm or Bank indicated by the additional Code word.  
AGATE . . . Send out by first opportunity a complete plant as under B. Specifications of the capacity indicated by the number added to this Code word.—Payment will be made by the Firm, or Bank.  
ATOM . . . Send out complete plant as under C. Specification of the size indicated by the number added to this Code word.—Payment will be made by the Firm, or Bank, also named after this Code word.  
ASBESTOS . . . Send as quickly as possible the goods named after this Code word.—Payment will be made by the Firm, or Bank.  
ASP . . . Send Specification and price of complete Gas Plant suitable for a town, the number of the inhabitants of which is added to the Code word for this sentence.  
BLOCK . . . The necessary fire-bricks, lumps, and fire-clay must be sent with the Apparatus.  
BURN . . . Send as quickly as possible a new Steam Boiler, Cornish type without fittings. Horse-power of Boiler is added to this Code word.  
EXCESS . . . Send Specifications and price of Steam Boiler, Engine, and Exhauster capable of passing per hour the number of cubic feet of Gas indicated by the number added to this Code word and representing thousands. *Example:* "Excess ten;" would imply what is embodied in the above sentence, and that the Exhauster should pass 10,000 cub. ft. per hour.  
CONTINUE . . . I (or We) have obtained the concession for lighting by Coal Gas the town or city of . . . Terms as stated in my last.  
WASTE . . . I (or We) have obtained the concession for Water supply for the town or city of . . . Terms as in my last.  
POPE . . . We shall require ordinary socket and spigot pipes proved to 300 feet head of Water. The numbers after this Code word indicating the number of "hundreds of yards" of pipe, and the letters a. b. c. d. &c., the diameter in inches. Details of connections, syphons, &c., to follow—  
a. b. c. d. e. f. g. h. i. k. l. m. n. o.  
1½ 2 2½ 3 4 5 6 7 8 9 10 12 14 15  
Thus: "Pope f. nine l. twelve" conveys the meaning that 900 yards of 5 inch, and 1,200 yards of 10 inch pipes will be required—proved with 300 feet head of water.  
LUCK . . . Prepare the number of lamp columns and lanterns named after this Code word.  
HERD . . . Send immediately Specifications and cost of Gas holder complete to diameter and depth named in feet after this Code word. To be delivered f. o. b., England. Give approximate weights of cast and wrought iron.  
COLT . . . Send particulars as under Code word "Herd," but include a cast-iron tank for same.

*Code Word.*  
WORT . . . Send particulars as under Code word "Herd," but include a wrought-iron tank for same.  
AIR . . . Send out immediately an Air-Light Apparatus for the number of lights indicated by the number added to this Code word.  
FIX . . . Send a trustworthy man out with the Apparatus to fix, and make best terms you can; fare out and home will be paid.

BANKS.

ANGEL . . . Anglo-Austrian Bank.  
ANGLER . . . The Anglo-Californian Bank, Limited.  
ANCIENT . . . Anglo-Egyptian Banking Co., Limited.  
ANGLICAN . . . Anglo-Foreign Banking Co., Limited.  
ANGINA . . . Anglo-Italian Bank, Limited.  
ANGORA . . . Anglo-Paraguayan Bank, Limited.  
ANCHOR . . . Anglo-Peruvian Bank, Limited.  
ANNO . . . Australian Joint Stock Bank.  
BEACON . . . Bank of Africa, Limited.  
BASIC . . . Bank of Australasia.  
BARDIC . . . Bank of British Columbia.  
BOBBIN . . . Bank of British North America.  
BONUS . . . Bank of Constantinople.  
BEAK . . . Bank of Egypt.  
BANNER . . . Bank of New South Wales.  
BON . . . Bank of New Zealand.  
BUR . . . Bank of Roumania.  
BOSS . . . Bank of South Australia.  
BOVINE . . . Bank of Victoria (Australia).  
CABIN . . . Chartered Bank of India, Australia, and China.  
COMIC . . . Chartered Mercantile Bank of India, London, and China.  
CAB . . . Colonial Bank.  
COUSIN . . . Colonial Bank of New Zealand.  
COOM . . . Commercial Bank of Alexandria.  
COTTER . . . Commercial Banking Company of Sydney.  
CENT . . . Comptoir d'Escompte de Paris.  
CEDE . . . Credit Lyonnais.  
DECIMAL . . . David (Cornielle) and Co.  
EBBING . . . English Bank of Rio de Janeiro.  
EXOTIC . . . Exchange and Investment Bank.  
HORAL . . . Hong Kong and Shanghai Banking Corporation.  
IBIS . . . Imperial Ottoman Bank.  
IOTA . . . Ionian Bank  
KALI . . . Keyser, A., and Co.  
LOAM . . . Land Mortgage Bank of India.  
LOIN . . . Land Mortgage Bank of Victoria, Limited.  
LARVA . . . London Bank of Mexico and South America, Limited.  
LABIAL . . . London Banking Association, Limited.  
LACONIC . . . London Chartered Bank of Australia.  
MODULE . . . Maritime Bank of the Dominion of Canada.  
MOPE . . . Mercantile Bank of Peru.  
MOSS . . . Mercantile Bank of Sydney.  
NEUTER . . . National Bank of Australasia.  
NOVA . . . National Bank of New Zealand, Limited.  
NAUTICAL . . . New London and Brazilian Bank (The), Limited.  
OASIS . . . Oriental Bank Corporation.  
OBIT . . . Queensland National Bank, Limited.  
SABLE . . . Standard Bank of British South Africa, Limited.  
UNIT . . . Union Bank of Australia.  
VERANDA . . . Western Australian Bank.

*Index to Sections.*

| <i>Sections</i>                                                                                                           | <i>Page</i> |
|---------------------------------------------------------------------------------------------------------------------------|-------------|
| <b>A</b> PATENT PORTABLE GAS APPARATUS . . . . .                                                                          | 13          |
| <b>B</b> RETORTS, BENCH FITTINGS, TOOLS, ETC. . . . .                                                                     | 23          |
| <b>C</b> CONDENSERS . . . . .                                                                                             | 31          |
| <b>D</b> EXHAUSTERS . . . . .                                                                                             | 37          |
| <b>E</b> SCRUBBERS AND WASHERS . . . . .                                                                                  | 41          |
| <b>F</b> PURIFIERS . . . . .                                                                                              | 49          |
| <b>G</b> STATION METER . . . . .                                                                                          | 57          |
| <b>H</b> GASHOLDERS . . . . .                                                                                             | 61          |
| <b>I</b> GOVERNORS . . . . .                                                                                              | 69          |
| <b>J</b> IMPROVED PATENT VALVES . . . . .                                                                                 | 71          |
| <b>K</b> EXPERIMENTAL APPARATUS . . . . .                                                                                 | 75          |
| <b>L</b> SPECIFICATIONS OF COAL GAS APPARATUS . . . . .                                                                   | 79          |
| " " OIL " " . . . . .                                                                                                     | 99          |
| <b>M</b> DISTRIBUTION OF GAS . . . . .                                                                                    | 103         |
| <b>N</b> SERVICES . . . . .                                                                                               | 111         |
| <b>O</b> STREET LAMPS, COLUMNS, AND BRACKETS . . . . .                                                                    | 115         |
| <b>P</b> CONSUMERS' METERS . . . . .                                                                                      | 123         |
| <b>Q</b> GAS FITTINGS . . . . .                                                                                           | 127         |
| <b>R</b> GAS HEATING AND COOKING STOVES . . . . .                                                                         | 131         |
| <b>S</b> SUNDRY TOOLS AND IMPLEMENTS . . . . .                                                                            | 137         |
| <b>T</b> OBSERVATIONS ON THE SELECTION OF THE MANUFACTURING PLANT, AND ON ERECTION, AND GENERAL REMARKS THEREON . . . . . | 149         |
| <b>U</b> PORTABLE GAS FOR LIGHTING RAILWAY TRAINS, TRAM CARS, ETC. . . . .                                                | 153         |
| <b>V</b> HEATING APPARATUS FOR CHURCHES, FACTORIES, ETC. . . . .                                                          | 155         |
| <b>W</b> USEFUL MEMORANDA, TABLES, ETC. . . . .                                                                           | 161         |
| <b>X</b> AIR-LIGHT APPARATUS . . . . .                                                                                    | 169         |
| <b>Y</b> GAS AS FUEL AND AS A MOTIVE POWER . . . . .                                                                      | 170         |
| <b>Z</b> THE PRESERVATION OF IRON AND STEEL FROM RUST . . . . .                                                           | 171         |
| ELECTRIC LIGHTING . . . . .                                                                                               | 173         |
| LIST OF WORKS ERECTED . . . . .                                                                                           | 174         |
| TELEGRAPHIC CODE . . . . .                                                                                                | 177         |

*General Index.*

| <i>Page</i>                                   | <i>Page</i> | <i>Page</i>                                                   |     |                                                              |     |
|-----------------------------------------------|-------------|---------------------------------------------------------------|-----|--------------------------------------------------------------|-----|
| Accessories of retort setting . . . . .       | 26          | Apparatus for determining the heating power of coal . . . . . | 78  | Boilers, hot water for setting in brick-work . . . . .       | 156 |
| Advantages of gas . . . . .                   | 12          | Apparatus for testing gas fittings . . . . .                  | 128 | " saddle . . . . .                                           | 156 |
| Air, expansion of . . . . .                   | 22          | " " mainpipes 113, 144 . . . . .                              | 144 | " welded . . . . .                                           | 159 |
| " " by heat . . . . .                         | 22          | " " mains . . . . .                                           | 144 | Boiling point of various liquids . . . . .                   | 28  |
| " and gas, mixture of . . . . .               | 40          | Areas of circles . . . . .                                    | 168 | Brackets, lamp for streets . . . . .                         | 119 |
| " light apparatus . . . . .                   | 169         | Argand burners . . . . .                                      | 130 | Breeze . . . . .                                             | 44  |
| " relative cooling effects of water . . . . . | 36          | Art of gas lighting allied to chemistry . . . . .             | 5   | Bricks and brickwork . . . . .                               | 161 |
| " and . . . . .                               | 36          | Artificial light, theory of . . . . .                         | 40  | Bromine test . . . . .                                       | 75  |
| " atmospheric effects upon gas . . . . .      | 36          | Bad gas generally the fault of bad fittings . . . . .         | 149 | Bromine test apparatus . . . . .                             | 78  |
| Air pump for testing mines . . . . .          | 144         | Balloons, supply of gas to . . . . .                          | 109 | Buckstaves ( <i>see</i> Pilasters) . . . . .                 |     |
| Alchemy . . . . .                             | 5           | Balances for chemical analyses . . . . .                      | 78  | Burner pliers . . . . .                                      | 140 |
| Alkalimeter . . . . .                         | 78          | Bamboo rods and torches . . . . .                             | 128 | Burners, patent, various . . . . .                           | 129 |
| Ammonia . . . . .                             | 44          | Barometers . . . . .                                          | 78  | " " " " description of . . . . .                             | 13  |
| " detection of . . . . .                      | 21          | Barrows for coal . . . . .                                    | 29  |                                                              |     |
| " extraction from gas . . . . .               | 46          | " " coke . . . . .                                            | 29  | Capital of the Metropolitan gas com-panies in 1875 . . . . . | 60  |
| " sulphate of, mode of manu-facture . . . . . | 45          | Bar iron, weight of . . . . .                                 | 167 | Cannel, illuminating power of gas from . . . . .             | 36  |
| " removed by scrubber or washer . . . . .     | 34, 41      | Bellows, smiths' . . . . .                                    | 137 | Carbon, bisulphide of . . . . .                              | 19  |
| " testing apparatus . . . . .                 | 77          | Bench drilling machine . . . . .                              | 139 | Carbonic acid . . . . .                                      | 33  |
| " table of strength of . . . . .              | 45          | Birmingham wire gauge, thickness of . . . . .                 | 166 | " oxide . . . . .                                            | 35  |
| " water . . . . .                             | 46          | Bisulphate of carbon, test apparatus . . . . .                | 78  | Carbonate of lime in coals . . . . .                         | 19  |
| Ammoniacal liquor as a manure . . . . .       | 48          | Bisulphide of carbon . . . . .                                | 34  | Carbonisation . . . . .                                      | 17  |
| Ammonia testing apparatus . . . . .           | 77          | Blocks, Weston's patent differential . . . . .                | 140 | Carburetted gases and air . . . . .                          | 152 |
| Analysis of coal . . . . .                    | 19          | Bogs of Great Britain and Ireland, extent of . . . . .        | 22  | Carter's valves . . . . .                                    | 128 |
| Analysis of coal and cannel . . . . .         | 59          | Boilers, patent hot water . . . . .                           | 155 | Cast iron balance weights . . . . .                          | 62  |
| Angle, iron weight of . . . . .               | 167         | " self-regulating . . . . .                                   | 155 | " drywell . . . . .                                          | 62  |
| Annular condenser . . . . .                   | 32          |                                                               |     | " girders . . . . .                                          | 62  |
| Anvils . . . . .                              | 127         |                                                               |     |                                                              |     |

GENERAL INDEX—continued

|                                               |         |                                               |          |                                             |     |
|-----------------------------------------------|---------|-----------------------------------------------|----------|---------------------------------------------|-----|
| Cast iron guide columns . . . . .             | 62      | Crab winch, double and single purchase        | 141      | Gas, fittings . . . . .                     | 128 |
| "    incrustation, removal of                 | 17      | Cramp and brace for mains . . . . .           | 139      | "    regulators . . . . .                   | 126 |
| Caulking tools . . . . .                      | 137     | Crutches for hydraulic main . . . . .         | 26       | "    reflectors . . . . .                   | 128 |
| Cements . . . . .                             | 101     | Decimal approximations to facilitate          |          | "    stands and shades . . . . .            | 128 |
| Cements for retort mouthpieces                | 25, 162 | calculations . . . . .                        | 168      | Gauges, pressure . . . . .                  | 77  |
| "    clay retorts . . . . .                   | 25      | Diffusion of gases . . . . .                  | 109      | Glycerine, application to meters            | 124 |
| Centre change valves . . . . .                | 56, 73  | Different temperatures and their              |          | Governors . . . . .                         | 69  |
| Chains, safe working load of . . . . .        | 168     | effects . . . . .                             | 20       | Guides for guide columns . . . . .          | 62  |
| Chain tested short link . . . . .             | 62      | Directions for testing gas . . . . .          | 21       | "    cast and wrought iron . . . . .        | 147 |
| Chain pulleys and carriages . . . . .         | 62      | Discharges of gas through pipes at            |          | Grindstone and trough . . . . .             | 142 |
| Charge of coal, quantity in . . . . .         | 17      | different pressures, tables of . . . . .      | 104      | Guide columns . . . . .                     | 62  |
| Chemical constituents of gas . . . . .        | 33      | Double-acting retort apparatus . . . . .      | 15       | Guide rollers . . . . .                     | 62  |
| Chemistry allied to gas making . . . . .      | 5       | Drain grate and frame . . . . .               | 147      | Guide trough . . . . .                      | 62  |
| Chisels . . . . .                             | 137     | Drilling machine, with bench, vice, &c.       | 138      |                                             |     |
| Chucks for lathes . . . . .                   | 143     | Drilling pillar, brace, &c. . . . .           | 139      | H-pipes and plugs . . . . .                 | 26  |
| Circular saw benches . . . . .                | 142     | Dry meters . . . . .                          | 124      | Hammers . . . . .                           | 137 |
| Circumferences of circles . . . . .           | 168     | Dry well for gasholder . . . . .              | 67       | Heat, comparative power of sub-             |     |
| Cisterns, hot water . . . . .                 | 160     | Effects of different temperatures . . . . .   | 20       | stances for conducting . . . . .            | 22  |
| Coal, analysis of . . . . .                   | 59      | "    the bombardment of Paris . . . . .       | 66       | "    list of non-conducting sub-            |     |
| "    carbonisation by the Metropoli-          |         | "    on the gas works . . . . .               | 66       | stances and fuel, remarks on . . . . .      | 20  |
| "    tan companies in 1875 . . . . .          | 26      | "    pressure on the consumption . . . . .    |          | "    importance of attention to,            |     |
| "    cutting machine . . . . .                | 22      | of gas . . . . .                              | 126      | "    in carbonising . . . . .               | 17  |
| "    formation of . . . . .                   | 30      | Electric lighting . . . . .                   | 173      | Heating apparatus, combined air and         |     |
| "    illuminating power of gas from           |         | Evaporation from water surfaces . . . . .     | 162      | water . . . . .                             | 157 |
| "    various . . . . .                        | 36      | Excavation . . . . .                          | 161      | Heating stoves . . . . .                    | 131 |
| "    atmospherical effects upon . . . . .     | 36      | Exhausters . . . . .                          | 37       | Hearth frames . . . . .                     | 137 |
| "    method of determining quantity . . . . . | 19      | Experimental apparatus . . . . .              | 75       | Hemp rope, safe working load of . . . . .   | 168 |
| "    of volatile matter and coke in . . . . . | 19      | Experimental meters . . . . .                 | 125      | History of gas-lighting . . . . .           | 5   |
| "    necessity for keeping dry . . . . .      | 18      | Expansion of air . . . . .                    | 22       | Holding down plates and bolts . . . . .     | 62  |
| "    "    weighing . . . . .                  | 18      | "    liquids . . . . .                        | 22       | Hooks, gas . . . . .                        | 112 |
| "    products of the destructive dis-         |         | "    solids . . . . .                         | 28       | Hot water coils and cases (plain and        |     |
| "    tillation of . . . . .                   | 35      | Files and rasps . . . . .                     | 138      | ornamental) . . . . .                       | 160 |
| "    volatile matter in . . . . .             | 20      | Fire brick retort . . . . .                   | 25       | Hot water boilers, self-contained . . . . . | 155 |
| "    gas, chemical constituents of . . . . .  | 33      | Firing shovels . . . . .                      | 29       | "    "    for setting in brick-             |     |
| "    "    deterioration of in contact         |         | Fittings for iron services . . . . .          | 112      | work . . . . .                              | 156 |
| "    "    with water . . . . .                | 109     | Flexible tubing . . . . .                     | 128      | "    pipes (patent) and connec-             |     |
| "    "    comparative cost of . . . . .       | 36      | Forges, portable . . . . .                    | 137      | "    "    common . . . . .                  | 158 |
| "    "    impurities, dilutants, and          |         | Formation of coal . . . . .                   | 30       | "    "    ornamental floor . . . . .        | 159 |
| "    "    illuminants in . . . . .            | 33      | Fountains, burning . . . . .                  | 5        | Hydraulic jacks (patent) . . . . .          | 141 |
| "    barrows . . . . .                        | 29      | Fuel, utilisation of . . . . .                | 22       | "    "    for forcing pipe into             |     |
| "    gas, proportion of hydrogen and          |         | Furnaces to be frequently clinkered . . . . . | 18       | "    joint . . . . .                        | 141 |
| "    carbure in . . . . .                     | 28      | Furnace doors and frames . . . . .            | 26       | Hydraulic mains . . . . .                   | 26  |
| "    "    purification from sulphu-           |         | Gas, advantages of . . . . .                  | 12       | Hydrometers . . . . .                       | 78  |
| "    "    retted hydrogen . . . . .           | 34      | "    apparatus, specifications of . . . . .   | 79       | Hygrometers . . . . .                       | 78  |
| Code, telegraphic . . . . .                   | 177     | "    applied to motive power . . . . .        | 9        |                                             |     |
| Coils and coil cases . . . . .                | 160     | "    chemical constituents . . . . .          | 33       | Illuminating power of gas supplied to       |     |
| Coke . . . . .                                | 44      | "    cost per hour . . . . .                  | 128      | various towns and cities . . . . .          | 30  |
| "    barrow . . . . .                         | 29      | "    deterioration when in contact            |          | "    power of, loss of . . . . .            | 28  |
| "    shovels . . . . .                        | 29      | "    with water . . . . .                     | 109      | "    power of gas from vari-                |     |
| Combined purifying apparatus . . . . .        | 51      | "    discharge through pipes . . . . .        | 104      | ous coals . . . . .                         | 36  |
| Combustion, how produced . . . . .            | 20      | "    distribution of . . . . .                | 103      | Illuminants in gas . . . . .                | 33  |
| Comparative illuminating power of             |         | "    from oil, tallow, resin, wood, and       |          | Illumination devices . . . . .              | 128 |
| the gas supplied to various                   |         | "    peat . . . . .                           | 15       | Imperfect fittings . . . . .                | 114 |
| towns and cities . . . . .                    | 30      | "    illuminating power of, from              |          | Impurities in gas . . . . .                 | 33  |
| "    illuminating power of gas                |         | "    various coals . . . . .                  | 36       | Inspection of fittings at regular in-       |     |
| "    from various coals . . . . .             | 36      | "    "    "    as supplied to                 |          | tervals . . . . .                           | 114 |
| "    power of substances for                  |         | "    various towns and cities . . . . .       | 30       | Iron girders . . . . .                      | 62  |
| "    conducting heat . . . . .                | 22      | "    impurities in . . . . .                  | 34       | Iron lamp pillars . . . . .                 | 116 |
| Composition pipe, weight of . . . . .         | 167     | "    marsh . . . . .                          | 35       | Iron principals for retort house roofing    | 151 |
| Compound centre change valve . . . . .        | 73      | "    pressures, table of square roots of      | 108      |                                             |     |
| Concessions . . . . .                         | 12      | "    refuse as a manure . . . . .             | 48       | Jack, patent hydraulic . . . . .            | 141 |
| Concrete . . . . .                            | 161     | "    residual products of . . . . .           | 44       | Jumping lights, measures for ascer-         |     |
| Construction of works, general re-            |         | "    safety of . . . . .                      | 12       | taining cause of . . . . .                  | 114 |
| marks on . . . . .                            | 102     | "    specific gravity, table of square        |          |                                             |     |
| Consumption of gas, effects of pres-          |         | "    roots of . . . . .                       | 108      | Lamps, advantages of shadowless . . . . .   | 115 |
| "    sure on . . . . .                        | 126     | "    supply to balloons . . . . .             | 108      | Lamp brackets . . . . .                     | 119 |
| "    of tar . . . . .                         | 161     | "    testing directions for . . . . .         | 21       | "    carriers . . . . .                     | 117 |
| Condensation . . . . .                        | 162     | "    works, concessions in foreign            |          | Lamp columns . . . . .                      | 116 |
| Condensers . . . . .                          | 31      | "    countries . . . . .                      | 12       | Lamps, street (shadowless) . . . . .        | 115 |
| Connecting pipes, bends, tees, &c.            | 147     | "    "    hints on selecting site . . . . .   | 12       | "    various . . . . .                      | 118 |
| Consumers' dry meters . . . . .               | 125     | "    "    tools and implements for . . . . .  | 28       | Lantern holders . . . . .                   | 121 |
| Consumers' wet meters . . . . .               | 123     | "    cooking stoves and hearths . . . . .     | 131, 134 | "    cocks . . . . .                        | 121 |
| Cooking by gas, advantages of . . . . .       | 136     | "    holders . . . . .                        | 61       | "    fittings . . . . .                     | 121 |
| Cooking stoves . . . . .                      | 131     | "    hooks . . . . .                          | 112      | Lathes . . . . .                            | 143 |
| Cork slide gasaliers . . . . .                | 128     |                                               |          | Lead pans and ladles . . . . .              | 113 |
| Cost of gas per hour, table of . . . . .      | 128     |                                               |          | Lead service pipe and fittings . . . . .    | 113 |
| Corrugated iron roofing . . . . .             | 162     |                                               |          |                                             |     |

GENERAL INDEX—*continued.*

|                                                  | Page   |                                                   | Page   |                                              | Page |
|--------------------------------------------------|--------|---------------------------------------------------|--------|----------------------------------------------|------|
| Lead pipe, weight of . . . . .                   | 167    | Pumps lift and force . . . . .                    | 148    | Specific gravity, &c., tables . . . . .      | 163  |
| Lids for mouthpieces . . . . .                   | 27     | " brass syphon . . . . .                          | 148    | Spirit levels . . . . .                      | 144  |
| Lifting apparatus for purifier lids . . . . .    | 56     | Pulley blocks . . . . .                           | 141    | Standard burners . . . . .                   | 78   |
| " hydraulic . . . . .                            | 56     | Punch . . . . .                                   | 141    | " sperm candles . . . . .                    | 78   |
| Light, magnesian . . . . .                       | 40     | " hydraulic . . . . .                             | 142    | Station governor . . . . .                   | 69   |
| " oxy-hydrogen . . . . .                         | 30     | Punching bears . . . . .                          | 142    | " meter . . . . .                            | 57   |
| " theory of artificial . . . . .                 | 40     | Purifiers . . . . .                               | 49     | Steam boilers and fittings . . . . .         | 147  |
| Lighting, street, history of . . . . .           | 122    | " sets of 4, with change valve . . . . .          | 53, 54 | Stocks, taps, and dies . . . . .             | 113  |
| " with torch, advantage of . . . . .             | 121    | " and connections . . . . .                       | 52     | Stoking tools . . . . .                      | 29   |
| Lignites as compared with coal . . . . .         | 22     | Purifiers, capacity of . . . . .                  | 52     | Storage of coal and coke . . . . .           | 162  |
| Lime for purification . . . . .                  | 56     | Purification, lime best for . . . . .             | 56     | Stoves, gas heating . . . . .                | 134  |
| Litmus paper, to make . . . . .                  | 21     | Purification, oxide . . . . .                     | 49     | Strength of ammonia water, method . . . . .  |      |
| Liquids, expansion of . . . . .                  | 22     | Products, residual . . . . .                      | 44     | of ascertaining . . . . .                    | 44   |
| Main cocks (iron) . . . . .                      | 112    | Purifying agent, tar as a . . . . .               | 48     | Street lighting, history of . . . . .        | 122  |
| Main pipes . . . . .                             | 103    | Radiating heat, proportionate power . . . . .     |        | Supply of gas to balloons . . . . .          | 109  |
| Main pipe testing apparatus . . . . .            | 113    | of various substances . . . . .                   | 22     | Sulphur in coal, remarks on . . . . .        | 19   |
| Main and service layers' truck . . . . .         | 146    | Railway carriage lighting . . . . .               | 153    | Swivel joints for tar suction pipe . . . . . | 148  |
| Magnesian light, the . . . . .                   | 40     | Railway trains, lighting by gas . . . . .         | 153    | Syphon boxes, traps, and covers . . . . .    | 110  |
| Management of gas . . . . .                      | 114    | Rain water pipe and spouting . . . . .            | 147    | Tanks for gasholders . . . . .               | 68   |
| Manufacture of sulphate of ammonia . . . . .     | 45     | Ratchet braces . . . . .                          | 131    | " cast and wrought iron . . . . .            | 147  |
| Marsh gas . . . . .                              | 33, 35 | Reflective power of various sub- . . . . .        |        | Tables and memoranda, useful . . . . .       | 161  |
| Maximum consumption to be pro- . . . . .         |        | stances . . . . .                                 | 22     | Tar, notes on . . . . .                      | 47   |
| vided for (must be noted in . . . . .            |        | Regulator, gas . . . . .                          | 126    | " as a purifying agent . . . . .             | 48   |
| selecting plant) . . . . .                       | 149    | Regulator lamp . . . . .                          | 122    | " fuel . . . . .                             | 18   |
| Measures, French . . . . .                       | 165    | Retorts . . . . .                                 | 23     | " pavement, method of making . . . . .       | 47   |
| Metal sheet, weight of square foot of . . . . .  | 166    | " accessories of . . . . .                        | 26     | Telegraphic code . . . . .                   | 177  |
| " plates . . . . .                               | 166    | " apparatus (double) . . . . .                    | 15     | Telescope gas holders . . . . .              | 62   |
| Meters, consumers' . . . . .                     | 123    | " (vertical) . . . . .                            | 14     | Temperature, corresponding degrees . . . . . |      |
| " dry . . . . .                                  | 124    | " brick . . . . .                                 | 25     | by various scales . . . . .                  | 163  |
| " station . . . . .                              | 57     | " cement for . . . . .                            | 25     | Temperature, effects of different . . . . .  |      |
| " test . . . . .                                 | 125    | " clay . . . . .                                  | 18     | " of retorts . . . . .                       | 17   |
| " wet . . . . .                                  | 123    | " incrustation of . . . . .                       | 17     | Testing apparatus for main pipes . . . . .   | 113  |
| " application of glycerine to . . . . .          | 124    | " iron . . . . .                                  | 18     | Testing gas, directions for . . . . .        | 21   |
| " observations on . . . . .                      | 57     | " settings of clay . . . . .                      | 24     | Test papers, how to make . . . . .           | 21   |
| Metropolitan gas companies' capital in . . . . . |        | " iron . . . . .                                  | 23     | Theory of artificial light . . . . .         | 41   |
| 1875 . . . . .                                   | 60     | " firebrick . . . . .                             | 25     | Thermometers . . . . .                       | 78   |
| " receipts . . . . .                             | 60     | " temperature of . . . . .                        | 17     | Torches for lamps . . . . .                  | 121  |
| Moisture in coal . . . . .                       | 20     | Residual products of gas . . . . .                | 44     | Tube cutters . . . . .                       | 140  |
| Mortar, cement, &c. . . . .                      | 161    | Rivetting hammers . . . . .                       | 137    | " pliers . . . . .                           | 140  |
| Mouthpieces for retorts . . . . .                | 26     | Roofs . . . . .                                   | 151    | " vice . . . . .                             | 136  |
| N pipes and plugs . . . . .                      | 26     | Saddle boilers . . . . .                          | 156    | Turf, gas from . . . . .                     | 16   |
| Napthalene . . . . .                             | 35     | Saw-benches, circular . . . . .                   | 142    | Valves, bypass . . . . .                     | 73   |
| Nitrogen . . . . .                               | 9      | Scales and grain weights . . . . .                | 78     | " Carter's . . . . .                         | 128  |
| Non-conducting substances . . . . .              | 22     | Scoops for charging retorts . . . . .             | 29     | " centre . . . . .                           | 73   |
| Notes on pressure . . . . .                      | 70     | Screwing stocks, taps, and dies . . . . .         | 113    | " change, advantage of . . . . .             | 50   |
| Observations on selecting gas plant . . . . .    | 149    | Screw-keys . . . . .                              | 138    | " compound . . . . .                         | 74   |
| " the erection of gas . . . . .                  |        | Scrubbers and washers . . . . .                   | 41     | " gas and water . . . . .                    | 71   |
| " works . . . . .                                | 142    | Scrubbers and washers, notes on . . . . .         | 41     | " hot water . . . . .                        | 159  |
| Oxy-hydrogen light . . . . .                     | 30     | Selection of manufacturing plant, ob- . . . . .   |        | " patent . . . . .                           | 71   |
| Oil gas . . . . .                                | 16     | servations on . . . . .                           | 149    | " through-way and slide . . . . .            | 72   |
| " apparatus . . . . .                            | 10     | Service cleaners . . . . .                        | 128    | Velocity of sound . . . . .                  | 164  |
| Oxide for purifying . . . . .                    | 49     | Services, notes on . . . . .                      | 111    | " wind . . . . .                             | 163  |
| Paranaphthelene . . . . .                        | 35     | Service pipes (lead) . . . . .                    | 113    | Vertical gas retort . . . . .                | 14   |
| Photometers . . . . .                            | 75     | Shadowless lamp . . . . .                         | 115    | Ventilators, skirting . . . . .              | 164  |
| Photometer, observations on . . . . .            | 75     | Shafting and gearing . . . . .                    | 147    | Vice, portable, and bench . . . . .          | 113  |
| Pilasters . . . . .                              | 27     | Shovels, charging . . . . .                       | 29     | " bench . . . . .                            | 138  |
| Pillars, cast iron . . . . .                     | 147    | " coke . . . . .                                  | 29     | Waggons, tip for coal . . . . .              | 29   |
| Picks . . . . .                                  | 138    | Sheer legs . . . . .                              | 144    | Warm air apparatus . . . . .                 | 157  |
| Platinum, light from . . . . .                   | 20     | Sinker pipes and syphons . . . . .                | 110    | Warming buildings, notes on . . . . .        | 160  |
| Pressure gauges, notes on . . . . .              | 77     | Site, choice of . . . . .                         | 12     | Water, ammoniacal . . . . .                  | 46   |
| " register . . . . .                             | 70     | Slates, roofing . . . . .                         | 162    | Water tuyere . . . . .                       | 137  |
| Price of gas, comparison of, in Eng- . . . . .   |        | Sledge hammers . . . . .                          | 137    | Washers . . . . .                            | 43   |
| lish and French measures . . . . .               | 166    | Slide valves . . . . .                            | 72     | Weight of angle iron . . . . .               | 166  |
| Portable forge . . . . .                         | 137    | Smith's bellows . . . . .                         | 137    | " metals . . . . .                           | 166  |
| " gas apparatus . . . . .                        | 13     | Solder . . . . .                                  | 78     | " lead and compo pipe . . . . .              | 166  |
| " steam boilers . . . . .                        | 147    | Special weights and measures . . . . .            | 166    | Weights and measures, English . . . . .      | 169  |
| " vice and bench . . . . .                       | 113    | Specifications of patent portable gas . . . . .   |        | " special mis- . . . . .                     |      |
| Pressure gauges . . . . .                        | 77     | " apparatus . . . . .                             | 80     | Weight bridges . . . . .                     | 145  |
| " registers . . . . .                            | 77     | Specifications of apparatus for supply . . . . .  |        | Window frames, cast iron . . . . .           | 152  |
| " of water against walls, &c. . . . .            | 163    | " of gas to mansions, railway . . . . .           |        | Wood blocks for gas fittings . . . . .       | 128  |
| " of wind . . . . .                              | 163    | " stations, &c. . . . .                           | 82     | Wrought iron cisterns . . . . .              | 148  |
| Pumps for tar, &c. . . . .                       | 148    | Specifications for the supply of gas to . . . . . |        | " tube . . . . .                             | 110  |
|                                                  |        | " villages, towns, and cities . . . . .           | 87     | " weight of . . . . .                        | 168  |
|                                                  |        | Specifications of apparatus for manu- . . . . .   |        | " fittings . . . . .                         | 110  |
|                                                  |        | " facture of gas from oil, &c. . . . .            | 99     |                                              |      |

# COMPANION

TO THE

GAS & WATER ENGINEER'S BOOK OF REFERENCE,

BEING A

## *LIST OF PRICES*

OF THE CHIEF ARTICLES CONTAINED THEREIN,

AS MANUFACTURED AND SUPPLIED BY

GEORGE BOWER,

*GAS AND WATER-WORKS' ENGINEER AND CONTRACTOR,*

ST. NEOTS, HUNTS.

NOTE.

*All Prices are subject to alteration corresponding with any variation in the cost of Materials or Labour.  
Packing, Packing Cases, and Delivery, only included where specially mentioned.*

# PRICES OF APPARATUS, ETC.,

MANUFACTURED AND SUPPLIED BY

## GEORGE BOWER,

*Gas and Water Engineer and Contractor, St. Neots, Hunts.*

### [SECTION A.] PATENT PORTABLE GAS APPARATUS.

*(Description, page 13 of Catalogue.)*

*(Specification and Details, page 80 of Catalogue.)*

|                                                                                                                           | No. 0<br>Apparatus,<br>6 to 8 burners. | No. 1<br>Apparatus,<br>10 to 15<br>burners. | No. 2<br>Apparatus,<br>20 to 25<br>burners. | No. 3<br>Apparatus,<br>30 to 40<br>burners. | No. 4<br>Apparatus,<br>40 to 50<br>burners. |
|---------------------------------------------------------------------------------------------------------------------------|----------------------------------------|---------------------------------------------|---------------------------------------------|---------------------------------------------|---------------------------------------------|
| Retort part . . . . .                                                                                                     | 8 4 0                                  | 14 10 0                                     | 22 5 0                                      | 24 10 0                                     | 36 10 0                                     |
| Purifier ditto . . . . .                                                                                                  | 8 4 0                                  | 15 15 0                                     | 15 15 0                                     | 17 10 0                                     | 17 10 0                                     |
| Gasholder ditto . . . . .                                                                                                 | 13 12 0                                | 29 15 0                                     | 34 0 0                                      | 48 0 0                                      | 56 0 0                                      |
| Prices of Apparatus, for export delivered at the<br>Docks in London, Liverpool, or Hull, inclusive<br>of Packing Cases. } | 30 0 0                                 | 60 0 0                                      | 72 0 0                                      | 90 0 0                                      | 110 0 0                                     |
| Prices of Apparatus for Home use, inclusive of<br>erection in England, but exclusive of carriage<br>from St. Neots. }     | 35 0 0                                 | 70 0 0                                      | 82 0 0                                      | 105 0 0                                     | 125 0 0                                     |

### PATENT DOUBLE-ACTING RETORT APPARATUS.

*(Page 15 of Catalogue.)*

| <i>Prices of Apparatus delivered at the Docks in<br/>London, Liverpool, or Hull, inclusive of<br/>Packing Cases.</i> | No. 1<br>Apparatus.                                                      | No. 2<br>Apparatus. | No. 3<br>Apparatus. | No. 4<br>Apparatus. | No. 5<br>Apparatus. | No. 6<br>Apparatus. |
|----------------------------------------------------------------------------------------------------------------------|--------------------------------------------------------------------------|---------------------|---------------------|---------------------|---------------------|---------------------|
| Apparatus for Oil Gas . . . . .                                                                                      | 18 0 0                                                                   | 47 0 0              | 70 0 0              | 86 0 0              | 95 0 0              | 180 0 0             |
| Iron Tank for ditto . . . . .                                                                                        | {<br>18 0 0<br>Iron tank for<br>this size in-<br>cluded in<br>Apparatus. | {<br>10 0 0         | {<br>17 10 0        | {<br>30 0 0         | {<br>60 0 0         | {<br>90 0 0         |

## RETORTS, ETC.

(Page 23 of Catalogue.)

## [SECTION B.] SETTINGS OF IRON RETORTS.

Prices include Delivery to Docks in London, Liverpool, or Hull.

| Size of Retorts.            | Retorts,<br>5 ft. × 14 in. ×<br>10 in. |                                          | Retorts,<br>6 ft. × 14 in. ×<br>12 in. |                                          | Retorts,<br>7 ft. × 14 in. ×<br>12 in. |                                          | Retorts,<br>7 ft. × 16 in. ×<br>15 in. |                                          | Retorts,<br>8 ft. × 16 in. ×<br>15 in. |                                          |
|-----------------------------|----------------------------------------|------------------------------------------|----------------------------------------|------------------------------------------|----------------------------------------|------------------------------------------|----------------------------------------|------------------------------------------|----------------------------------------|------------------------------------------|
|                             | Iron Work.                             | Fire Bricks,<br>Lumps,<br>and Fire Clay. | Iron Work.                             | Fire Bricks,<br>Lumps,<br>and Fire Clay. | Iron Work.                             | Fire Bricks,<br>Lumps,<br>and Fire Clay. | Iron Work.                             | Fire Bricks,<br>Lumps,<br>and Fire Clay. | Iron Work.                             | Fire Bricks,<br>Lumps,<br>and Fire Clay. |
| Setting of 1 Retort, Fig. 1 | £ 19 0                                 | £ 5 0                                    | £ 20 0                                 | £ 6 0                                    | £ 20 0                                 | £ 8 0                                    | £ ...                                  | £ ...                                    | £ ...                                  | £ ...                                    |
| " 2 Retorts, " 2            | 36 0                                   | 10 0                                     | 37 0                                   | 11 0                                     | 38 0                                   | 12 0                                     | ...                                    | ...                                      | ...                                    | ...                                      |
| " 2 " " 3                   | ...                                    | ...                                      | 38 0                                   | 12 0                                     | 40 0                                   | 14 0                                     | ...                                    | ...                                      | ...                                    | ...                                      |
| " 3 " " 4                   | ...                                    | ...                                      | 55 0                                   | 14 0                                     | 57 0                                   | 15 0                                     | 66 0                                   | 18 0                                     | 70 0                                   | 20 0                                     |
| " 5 " "                     | ...                                    | ...                                      | 87 0                                   | 18 0                                     | 90 0                                   | 20 0                                     | 107 0                                  | 23 0                                     | 114 0                                  | 26 0                                     |
| " 7 " "                     | ...                                    | ...                                      | ...                                    | ...                                      | 115 0                                  | 25 0                                     | 140 0                                  | 28 0                                     | 145 0                                  | 30 0                                     |

SINGLE RETORT, 4 ft. by 12 in. by 12 in., as described on page 24. Complete, with all materials ready for Setting, £27.

## SETTINGS OF CLAY RETORTS.

| Size of Retorts.     | Retorts,<br>8 ft. × 17 in. × 13 in. |                                                          | Retorts,<br>8 ft. × 14 in. diameter |                                                          | Retorts,<br>8 ft. × 15 in. diameter |                                                          | Retorts,<br>8 ft. × 18 in. diameter |                                                          |
|----------------------|-------------------------------------|----------------------------------------------------------|-------------------------------------|----------------------------------------------------------|-------------------------------------|----------------------------------------------------------|-------------------------------------|----------------------------------------------------------|
|                      | Iron Work.                          | Clay Retorts,<br>Fire Bricks,<br>Lumps,<br>and Fire Clay | Iron Work.                          | Clay Retorts,<br>Fire Bricks,<br>Lumps,<br>and Fire Clay | Iron Work.                          | Clay Retorts,<br>Fire Bricks,<br>Lumps,<br>and Fire Clay | Iron Work.                          | Clay Retorts,<br>Fire Bricks,<br>Lumps,<br>and Fire Clay |
| Setting of 3 Retorts | £ 45 0                              | £ 27 0                                                   | £ 42 0                              | £ 25 0                                                   | £ 45 0                              | £ 26 0                                                   | £ 48 0                              | £ 32 0                                                   |
| " 5 " "              | 66 0                                | 47 0                                                     | 62 0                                | 44 0                                                     | 66 0                                | 45 0                                                     | 70 0                                | 52 0                                                     |
| " 7 " "              | 90 0                                | 60 0                                                     | 80 0                                | 52 0                                                     | 90 0                                | 52 0                                                     | 95 0                                | 67 0                                                     |
| " 8 " "              | 100 0                               | 67 0                                                     | 90 0                                | 60 0                                                     | 100 0                               | 65 0                                                     | 110 0                               | 77 0                                                     |

## SUNDRIES.

D, OVAL or CIRCULAR CLAY RETORTS, not exceeding 20 inches in width, from 10/6 to 15/- per foot, packed and delivered to Docks, London, Liverpool, or Hull.

FIRE BRICK RETORTS, as described on page 25. Prices according to Specifications.

## IRON RETORTS.

D, ROUND, OVAL, and EAR SHAPED . . . . . from 20/- to 30/- per foot.

## ACCESSORIES OF RETORT SETTINGS.

CAST-IRON MOUTH PIECES, faced and fitted with Bolts and Two Lids, Figs. 1, 2, 3, 4, 5, Circular to 15 in., 40/- per Set.

" " " " D Shaped and Oval . . . . . from 18 " 50/- "

WROUGHT-IRON EARS, Cross Bars and T Screws, Fig. 10 . . . . . " 30/- to 55/- "

ECCENTRIC LEVER CROSS-BARS " 9 . . . . . " 30/- "

MORTON'S LIDS, with HOLMAN'S Patent Fastenings . . . . . " 45/- "



SIGHT BOXES, Figs. 6, 7, & 8, from 1s. 6d. to 2s. each.

SADDLE FLANGE SOCKET PIPES . . . . .  
 ASCENSION PIPES . . . . .  
 N CURVE or H PIPES, Figs. 11, 12, 13, from 35s. to 65s. per Set } From 3 to 6 inches.  
 DIP PIPES . . . . .

WROUGHT-IRON HYDRAULIC MAINS, Prices according to specification.

CAST-IRON HYDRAULIC MAINS, circular, Fig. 16, to 12 in. diam., about 18s. per foot.  
 " " " " 14 " 22s. "  
 " " " " 16 " 25s. "  
 " " " D shaped, " 15, 16 in. by 13 in. 28s. "  
 CAST-IRON CRUTCHES, Fig. 17, Fig. 18, Fig. 19.  
 Prices 16s. 20s. 16s. per pair.

DOUBLE FURNACE DOOR AND FRAME, Fig. 20, 10 in. wide, 33s. each.

SINGLE " " " 21 " 26s. "

BUCKSTAVES, 7 to 11 ft., Figs. 22, 23, 24, 12s. to 44s. each.

CROSS GIRDERS and DWARF PILASTERS, per setting, 1 to 7 Retorts, 8s. to 24s. per set.

TIERODS, with Bolts, Nuts, and Washers, per set for single beds of, from 1 to 7 Retorts, 15s. to 75s. per set.

BEST STOURBRIDGE AND NEWCASTLE, WELSH, AND OTHER FIRE BRICKS, LUMPS AND FIRE CLAY FROM STOCK, at current Prices.

(Page 29 of Catalogue.)

TOOLS AND IMPLEMENTS.

COAL WAGGONS for 2 ft. Gauge, Fig. 1 and 2, to hold from 10 to 15 cwt., for end or side tip £25 each.

LIGHT RAILS and FASTENINGS for ditto, at per 100 double yard, about £10.

POINTS, CROSSINGS, per set.  
 TURNTABLES, each.

HYDRAULIC or BALANCE ELEVATORS, or HOISTS, according to specifications.

IRON COAL BARROWS, to hold 2½ cwt., Fig. 4 £3 10s. each.

" COKE " " 2 " " 3 4 10 "

" SHOVELS (steel) " 5 0 10 "

CHARGING " " 6 from 0 5 "

STEEL COAL CHARGING SCOOP, with wrought-iron handle and horse, Figs. 7 & 8, from 65s. each.  
 IRON " " " " " " " " 35s. "

SET OF STOKING TOOLS, Fig. 9, 10, 11, 12, 13, from 18s. to 40s. per set.

AUGER for ascension pipe, Fig. 14, from 10s. each.

[SECTION C.]

CONDENSERS.

(Page 31 of Catalogue.)

CAST-IRON VERTICAL PIPE CONDENSERS.

| 2 in. CONDENSER, with 10 Pipes, 7 ft. high . . . . . | £   | s. |
|------------------------------------------------------|-----|----|
| 3 " " " 10 " 11 " . . . . .                          | 8   | 0  |
| 3 " " " 12 " 11 " . . . . .                          | 13  | 0  |
| 4 " " " 6 " 11 " . . . . .                           | 18  | 0  |
| 4 " " " 14 " 11 " . . . . .                          | 12  | 0  |
| 5 " " " 6 " 20 " . . . . .                           | 25  | 0  |
| 5 " " " 10 " 20 " . . . . .                          | 23  | 0  |
| 6 " " " 10 " 20 " . . . . .                          | 40  | 0  |
| 6 " " " 12 " 20 " . . . . .                          | 51  | 0  |
| 8 " " " 12 " 20 " . . . . .                          | 90  | 0  |
| 8 " " " 18 " 20 " . . . . .                          | 135 | 0  |

CAST-IRON ANNULAR CONDENSERS.

(Page 32 of Catalogue.)

| Diameter of Outside Cylinder, 1 ft. 9 in., 2 ft., 2 ft. 6 in., 3 ft. | 1 ft. 6 in., 2 ft., 2 ft. 6 in. | 3 ft. 6 in. |
|----------------------------------------------------------------------|---------------------------------|-------------|
| " Inside " 1 ft., 1 ft. 6 in., 2 ft., 2 ft. 6 in.                    | 9 ft., 9 ft., 9 ft., 10 ft.     |             |
| Height of Cylinders, 9 ft., 9 ft., 9 ft., 10 ft.                     |                                 |             |
| Price, each £17 10s. £19 os. £25 os. £30 os.                         |                                 |             |

CONNECTIONS FOR VERTICAL PIPE CONDENSERS, Consisting of 2 Dip Cisterns and Connecting Pipe, Double and Single Capped Pipes, Dip Pipes and Tees.

|                               |                 |
|-------------------------------|-----------------|
| For 2 in. Condenser . . . . . | £3 5s. per Set. |
| " 3 " " . . . . .             | 4 10 "          |
| " 4 " " . . . . .             | 5 5 "           |
| " 5 " " . . . . .             | 5 15 "          |
| " 6 " " . . . . .             | 6 10 "          |
| " 8 " " . . . . .             | 10 0 "          |

CONNECTIONS FOR ANNULAR CONDENSERS, Consisting of 1 Dip Cistern, Double-capped Inlet and Outlet Bends and Tees.

|                                     |                  |
|-------------------------------------|------------------|
| For 1 ft. 9 in. Condenser . . . . . | £2 15s. per Set. |
| " 2 ft. " " . . . . .               | 3 0 "            |
| " 2 ft. 6 in. " . . . . .           | 5 0 "            |
| " 3 ft. " " . . . . .               | 6 0 "            |

## EXHAUSTERS.

Prices given on application for exhausters and engines, with all connections, self-acting by pass valves, governor, etc., complete as shown by Figs. 1, 2, 3, pp. 38 and 39.

An arrangement similar to Fig. 3, to pass 3,000 cubic feet per hour, with engine and exhauster on planed bed plate, with all valves, connections, and governor complete, and fitted in the best manner, would cost £135.

An arrangement in duplicate, more convenient for shipment, with the engines and exhausters on separate bed plates, planed to fit one to another, with all connections, valves, and governor complete, each to pass 3,000 cubic feet, £270.

The engines are of power sufficient for working pumps, etc.

## [SECTION E.] SCRUBBERS AND WASHERS.

(Page 41 of Catalogue).

## CAST IRON SCRUBBERS,

Plain Cylinder fitted with cap and base, two tiers of sieves and water spreader—similar to Fig. 1.

| Size of Scrubber. | 2 ft. diameter,<br>9 ft. high. | 2 ft. 6 in. diameter,<br>9 ft. high. | 3 ft. diameter,<br>9 ft. 6 in. high. |
|-------------------|--------------------------------|--------------------------------------|--------------------------------------|
| Price, each . . . | £ s. d.<br>20 0 0              | £ s. d.<br>27 0 0                    | £ s. d.<br>30 0 0                    |

For connection and pipes to Scrubbers, see below.

*Wrought Iron Scrubbers, same sizes and prices.*

## CAST-IRON SCRUBBERS,

Made up of cylinders, with faced flanges, fitted with two tiers of iron sieves, top and bottom plates, charging and cleaning doors, and water spreader—similar to Fig. 2.

| Size of Scrubber. | 3 ft. diameter,<br>13 ft. high. | 4 ft. diameter,<br>12 ft. high. | 5 ft. diameter,<br>12 ft. high. | 5 ft 6 in. diameter,<br>16 ft. high. |
|-------------------|---------------------------------|---------------------------------|---------------------------------|--------------------------------------|
| Price, each . . . | £ s. d.<br>38 0 0               | £ s. d.<br>50 0 0               | £ s. d.<br>78 0 0               | £ s. d.<br>100 0 0                   |

*Special quotations given for large sizes.*

## CONNECTIONS FOR SCRUBBERS,

Including 4 flanged and capped Bends for inlet and outlet, 2 T's for inlet and outlet, pipe for connecting between outlet bend and T, 2 dip cisterns and 1 4-in. tar pipe.

| Diameter, 3 in.  | 4 in.            | 5 in.             | 6 in.             | 8 in.             |
|------------------|------------------|-------------------|-------------------|-------------------|
| £ s. d.<br>6 0 0 | £ s. d.<br>8 0 0 | £ s. d.<br>10 0 0 | £ s. d.<br>12 0 0 | £ s. d.<br>18 0 0 |

For prices of By-pass Valves, see SECTION J.

CAST-IRON LIQUOR TANK, 3 ft. diameter × 3 ft. deep, fitted with wood lid, and pillars for supporting it on the top of Scrubber, £7.

*Special quotations given for Washers of any description.*

## [SECTION F.] PATENT COMBINED PURIFYING APPARATUS.

(Page 50 of Catalogue.)

| Number of Combined Apparatus. | 0           | 1             | 2             | 3             | 4             | 5             | 5a            | 6             |
|-------------------------------|-------------|---------------|---------------|---------------|---------------|---------------|---------------|---------------|
| Price, each . . .             | £ s.<br>8 4 | £ s.<br>15 15 | £ s.<br>17 10 | £ s.<br>36 10 | £ s.<br>67 10 | £ s.<br>102 0 | £ s.<br>126 0 | £ s.<br>160 0 |

PURIFIERS.

| Size. |     |         | Size. |     |       | £ | s. | d. | Size. |     |     | £                         | s. | d.   |     |         |   |   |   |     |   |   |
|-------|-----|---------|-------|-----|-------|---|----|----|-------|-----|-----|---------------------------|----|------|-----|---------|---|---|---|-----|---|---|
| ft.   | in. | ft. in. | ft.   | in. | ft.   |   |    |    | in.   | ft. | in. |                           |    |      | ft. | in.     |   |   |   |     |   |   |
| 2     | 6   | x 2 6   | 2     | 6   | x 2 8 | - | -  | -  | 14    | 0   | 0   | 6                         | 0  | x 6  | 0   | x 3 6   | - | - | - | 74  | 0 | 0 |
| 3     | 4   | x 2 6   | 2     | 6   | x 2 0 | - | -  | -  | 18    | 0   | 0   | (With 4 tiers of Sieves.) |    |      |     |         |   |   |   |     |   |   |
| *5    | 0   | x 2 3   | 2     | 6   | x 2 6 | - | -  | -  | 22    | 10  | 0   | 6                         | 0  | x 6  | 0   | x 3 10½ | - | - | - | 78  | 0 | 0 |
| *6    | 0   | x 2 6   | 2     | 6   | x 2 6 | - | -  | -  | 27    | 0   | 0   | 8                         | 0  | x 8  | 0   | x 3 6   | - | - | - | 100 | 0 | 0 |
| 5     | 0   | x 4 0   | 2     | 6   | x 2 6 | - | -  | -  | 35    | 0   | 0   | 8                         | 0  | x 8  | 0   | x 3 9   | - | - | - | 108 | 0 | 0 |
| *8    | 0   | x 3 6   | 2     | 6   | x 2 6 | - | -  | -  | 42    | 0   | 0   | 12                        | 0  | x 12 | 0   | x 3 9   | - | - | - | 195 | 0 | 0 |
| 6     | 0   | x 6 0   | 2     | 6   | x 2 6 | - | -  | -  | 68    | 0   | 0   | 16                        | 0  | x 16 | 0   | x 4 10  | - | - | - | 280 | 0 | 0 |

\* These Purifiers are made with Division Plates.

No. 1. ORDINARY LIFTING CARRIAGE, suitable for Purifiers up to 12 ft. square, fitted with wheels, square threaded lifting screw and handle with swivel hooks, from 6os. to 8os. each.

LIFTING CARRIAGES, and gear of other descriptions and for Heavy Lids, on application.

PURIFIER SIEVES OF WOOD OR IRON. CONNECTING PIPES, ETC.

[SECTION G.]

(Page 57 of Catalogue.)

STATION METERS,  
WITH CYLINDRICAL CASES.

| Cubic Feet of Gas to pass per hour | 350     | 500    | 750    | 1000   | 1500   | 2000   | 3000   | 4000   | 5000   |
|------------------------------------|---------|--------|--------|--------|--------|--------|--------|--------|--------|
| Prices                             | £ 17 10 | £ 22 0 | £ 30 0 | £ 35 0 | £ 45 0 | £ 55 0 | £ 61 0 | £ 72 0 | £ 87 0 |

With Time Piece and Tell-Tale £10 extra.

Larger sizes quoted on application.

[SECTION H.]

(Page 68 of Catalogue.)

GASHOLDERS AND TANKS OF STANDARD SIZES.

| Size of Gas-holders in feet    | 5x2½  | 6x4    | 6x6    | 8x8    | 10x6   | 12x8   | 14x8   | 16x10  | 18x10  | 20x10   | 22x10   | 25x10   | 30x10   | 30x12   |
|--------------------------------|-------|--------|--------|--------|--------|--------|--------|--------|--------|---------|---------|---------|---------|---------|
| Prices of Gas-holders          | £ 6 0 | £ 23 0 | £ 28 0 | £ 38 0 | £ 45 0 | £ 50 0 | £ 60 0 | £ 76 0 | £ 98 0 | £ 112 0 | £ 124 0 | £ 140 0 | £ 180 0 | £ 196 0 |
| Prices of Iron Tanks for ditto | 5 2   | 7 10   | 11 0   | 21 0   | 28 0   | 75 0   | 90 0   | 115 0  | 145 0  | 174 0   | 204 0   | 251 0   | 320 0   | 334 0   |
| Size of Gas-holders in feet    | 35x10 | 40x12  | 45x15  | 50x15  | 55x16  | 60x18  | 60x20  | 65x20  | 70x20  | 80x20   |         |         |         |         |
| Prices of Gas-holders          | £ 230 | £ 310  | £ 456  | £ 552  | £ 850  | £ 895  | £ 1150 | £ 1140 | £ 1500 | £ 1920  |         |         |         |         |
| Prices of Iron Tanks for ditto | 399   | 581    | 855    | 992    | 1231   | 1480   | 1530   | 1880   | 2230   | 3306    |         |         |         |         |

TELESCOPIC GASHOLDERS.  
CAST-IRON GUIDE COLUMNS, OR TRIPODS.  
CAST AND WROUGHT-IRON GIRDERS, FOR TOP OF COLUMNS.  
GUIDE ROLLERS, WITH CARRIAGES, Etc.  
CAST AND WROUGHT-IRON GUIDE TROUGHS.  
CAST-IRON DRY "WELLS, with Divisions at Bottom, forming Inlet and Outlet Tank Syphons, for one or more Gasholders, as desired.

CHAIN PULLEYS, WITH CARRIAGES, Etc.  
TESTED SHORT LINK CHAIN.  
CAST-IRON BALANCE WEIGHTS.  
HOLDING-DOWN BOLTS.  
HOLDING-DOWN PLATES.  
TANK SYPHON BOXES, FITTED.  
FLANGE OR DUCK-FOOT BENDS.  
SUCTION BENDS.

Prices according to Specifications.

## [SECTION I.]

## STATION GOVERNORS.

(Page 69 of Catalogue.)

(Page 70 of Catalogue.)

| Size of Connecting Pipes, in inches | 3    | 4    | 5    | 6    | 6    | 8    | 10   | 12   |
|-------------------------------------|------|------|------|------|------|------|------|------|
| Price                               | £ 12 | £ 18 | £ 22 | £ 29 | £ 30 | £ 40 | £ 50 | £ 60 |

## [SECTION J.]

## IMPROVED PATENT VALVES.

(Pages 71 and 72 of Catalogue.)

## THROUGH-WAY OR STOP VALVES.

| Size of Connecting Pipe, in inches    | 2              | 3              | 4             | 5              | 6              | 7             | 8              | 9              | 10              | 12             |
|---------------------------------------|----------------|----------------|---------------|----------------|----------------|---------------|----------------|----------------|-----------------|----------------|
| Prices of Rising Plug Valve (Page 71) | £ s. d. 1 13 0 | £ s. d. 2 8 0  | £ s. d. 3 7 0 | £ s. d. 4 8 0  | £ s. d. 5 2 0  | £ s. d. 7 8 0 | £ s. d. 9 15 0 | £ s. d. 10 6 0 | £ s. d. 10 17 0 | £ s. d. 13 0 0 |
| Prices of Slide Valves (Page 72)      | £ s. d. 1 8 0  | £ s. d. 1 16 0 | £ s. d. 2 8 0 | £ s. d. 2 17 6 | £ s. d. 3 12 0 | £ s. d. 4 8 0 | £ s. d. 5 4 0  | £ s. d. 6 1 6  | £ s. d. 7 0 0   | £ s. d. 9 0 0  |

(Page 73 of Catalogue.) BY-PASS FOUR-WAY AND SHUT-OFF VALVES.

| Size of Connecting Pipe, in inches | 2              | 3              | 4              | 5             | 6              | 8              | 10             | 12             |
|------------------------------------|----------------|----------------|----------------|---------------|----------------|----------------|----------------|----------------|
| Price                              | £ s. d. 2 10 0 | £ s. d. 2 17 6 | £ s. d. 3 15 0 | £ s. d. 6 0 0 | £ s. d. 7 10 0 | £ s. d. 11 0 0 | £ s. d. 15 0 0 | £ s. d. 18 0 0 |

## CENTRE CHANGE VALVES, FOR PURIFIERS.

| Size of Connecting Pipe, in inches               | 3             | 4              | 5              | 6              | 8              | 9      | 10     | 12     |
|--------------------------------------------------|---------------|----------------|----------------|----------------|----------------|--------|--------|--------|
| Price for 2 Purifiers                            | £ s. d. 9 0 0 | £ s. d. 10 0 0 | £ s. d. 12 0 0 | £ s. d. 14 0 0 | £ s. d. 20 0 0 | ...    | ...    | ...    |
| Price for 3 Purifiers                            | 10 10 0       | 12 0 0         | 15 0 0         | 20 0 0         | 24 0 0         | 30 0 0 | ...    | ...    |
| Price for 4 Purifiers, 3 in & 1 out              | 14 0 0        | 17 0 0         | 19 0 0         | 26 0 0         | 34 0 0         | 38 0 0 | 45 0 0 | 54 0 0 |
| Price for 4 Purifiers, to work 1, 2, 3, or all 4 | 22 0 0        | 25 0 0         | 28 0 0         | 36 0 0         | 48 0 0         | 54 0 0 | 60 0 0 | 72 0 0 |

## [SECTION K.]

## EXPERIMENTAL APPARATUS.

(Page 75 of Catalogue.)

|                                                                                                                                                                                                  |   |   |   |   |      |                |
|--------------------------------------------------------------------------------------------------------------------------------------------------------------------------------------------------|---|---|---|---|------|----------------|
| BUNSEN PHOTOMETER, 50, 60, 75, or 100 inches                                                                                                                                                     | - | - | - | - | from | £ s. d. 4 10 0 |
| BUNSEN PHOTOMETER, similar to the above, with gas pillar fitted with micrometer cock pressure gauge, sliding candle pillar for adjusting height of candle—candle holders for one and two candles | - | - | - | - | -    | 8 0 0          |
| SUGG'S 60 inch BAR PHOTOMETER, complete as described on page 76 of Catalogue                                                                                                                     | - | - | - | - | -    | 67 16 6        |
| LOWE'S JET PHOTOMETER (see page 78)                                                                                                                                                              | - | - | - | - | -    | 12 10 0        |
| AMMONIA TESTING APPARATUS, complete as described on page 77 of Catalogue                                                                                                                         | - | - | - | - | -    | 4 6 0          |
| SULPHURETTED HYDROGEN TESTING APPARATUS                                                                                                                                                          | - | - | - | - | -    | 3 10 0         |
| SULPHUR TESTING APPARATUS                                                                                                                                                                        | - | - | - | - | -    | 46 13 1        |
| Chemicals for ditto                                                                                                                                                                              | - | - | - | - | -    | 2 2 0          |
| TABLE for ascertaining quantity of Sulphur                                                                                                                                                       | - | - | - | - | -    | 0 0 6          |

EXPERIMENTAL APPARATUS—continued.

The Method of Testing for Ammonia and Sulphur - - - - - £0 0 6  
 FORMS OF Sulphur and Ammonia Tests (250 bound) - - - - - 0 10 0  
 EXHAUST AND PRESSURE REGISTER, with 8 day clock - - - - - 20 0 0  
 PRESSURE GAUGES:—(Page, 77.)

|                                                                                                |                |     |     |           |              |      |      |            |
|------------------------------------------------------------------------------------------------|----------------|-----|-----|-----------|--------------|------|------|------------|
|                                                                                                | Boxwood Scale. |     |     |           | Ivory Scale. |      |      |            |
|                                                                                                | 4              | 5   | 6   | 8 inches. | 6            | 8    | 10   | 12 inches. |
| Price each                                                                                     |                |     |     |           | 14/-         | 16/- | 18/- | 21/-       |
| GLASS TUBE PRESSURE GAUGES, }<br>with union and brass bend, }<br>with socket end. Price each } | 8/-            | 8/6 | 9/- | 11/-      | 12/-         | 14/- | 16/- | 18/-       |

INSPECTOR'S POCKET GAUGE, in neat leather covered case, 25/- to 30/-

[SECTION L.]

COAL-GAS APPARATUS.

(Page 79 of Catalogue.)

PRICES OF APPARATUS, AS PER SPECIFICATIONS A.

Packed and delivered to Docks, London, Liverpool, or Hull.

| Number.                             | 5     | 6     | 7     | 8     | 9     | 10    | 11    | 12    | 13     | 14     |
|-------------------------------------|-------|-------|-------|-------|-------|-------|-------|-------|--------|--------|
| Export Price of Apparatus           | £ 128 | £ 141 | £ 234 | £ 303 | £ 363 | £ 430 | £ 610 | £ 772 | £ 1116 | £ 1383 |
| Home Price, Fixed but not Delivered | 140   | 155   | 250   | 322   | 390   | 460   | 650   | 822   | 1188   | 1480   |
| Price of Fire Bricks                | £ 5   | £ 7   | £ 12  | £ 21  | £ 24  | £ 27  | £ 35  | £ 43  | £ 54   | £ 74   |

PRICES OF APPARATUS, AS PER SPECIFICATIONS B.

| Number.                             | 1     | 2     | 3     | 4     | 5     | 6     | 7      | 8      | 9      | 10     | 11     | 12     |
|-------------------------------------|-------|-------|-------|-------|-------|-------|--------|--------|--------|--------|--------|--------|
| Export Price                        | £ 362 | £ 398 | £ 462 | £ 556 | £ 766 | £ 917 | £ 1233 | £ 1852 | £ 2545 | £ 3040 | £ 3944 | £ 6965 |
| Home Price, Fixed but not Delivered | 381   | 420   | 501   | 594   | 830   | 1000  | 1345   | 2000   | 2715   | 3240   | 4213   | 7264   |
| Price of Fire Bricks                | £ 19  | £ 24  | £ 27  | £ 31  | £ 39  | £ 43  | £ 56   | £ 74   | £ 93   | £ 88   | £ 109  | £ 211  |

PRICES OF OIL-GAS APPARATUS, AS PER SPECIFICATIONS C.

| Number.                             | 1     | 2     | 3     | 4     | 5     | 6     | 7     |
|-------------------------------------|-------|-------|-------|-------|-------|-------|-------|
| Export Price                        | £ 120 | £ 180 | £ 260 | £ 310 | £ 440 | £ 560 | £ 800 |
| Home Price, Fixed but not Delivered | 130   | 195   | 277   | 330   | 460   | 600   | 840   |

[SECTION M.]

PIPES FOR GAS AND WATER MAINS,

(Page 103 of Catalogue.)

To Special Quotations.

| Diameter of Pipes in inches. | 1½      | 2       | 2½      | 3       | 4       | 5       | 6       | 7       | 8       | 9       | 10      | 12      | 14      | 15      |
|------------------------------|---------|---------|---------|---------|---------|---------|---------|---------|---------|---------|---------|---------|---------|---------|
| Price per Ton                | £ s. d. | £ s. d. | £ s. d. | £ s. d. | £ s. d. | £ s. d. | £ s. d. | £ s. d. | £ s. d. | £ s. d. | £ s. d. | £ s. d. | £ s. d. | £ s. d. |

CONNECTIONS.

|                                  |   |
|----------------------------------|---|
| 1½ to 2½ inches diameter per ton | - |
| 3 " 6 " " " "                    | - |
| 7 " 15 " " " "                   | - |

£ s. d.

EXTRA PER TON FOR COATING.

If with Patent Solution -  
 If by Bower's process and Patent Solution.

£ s. d.

SYPHON OR CONDENSATION BOXES.

| Diameter of Main, in inches. | 1½           | 2           | 2½          | 3           | 4           | 5            | 6            | 7           | 8            | 9            | 10          | 12          | 14           | 15           | 18           |
|------------------------------|--------------|-------------|-------------|-------------|-------------|--------------|--------------|-------------|--------------|--------------|-------------|-------------|--------------|--------------|--------------|
| Price, each fitted           | £ s. d. 18 0 | £ s. d. 1 0 | £ s. d. 1 1 | £ s. d. 1 3 | £ s. d. 1 6 | £ s. d. 1 10 | £ s. d. 1 15 | £ s. d. 2 0 | £ s. d. 2 10 | £ s. d. 2 15 | £ s. d. 3 0 | £ s. d. 4 0 | £ s. d. 4 15 | £ s. d. 5 10 | £ s. d. 7 10 |

SYPHON TRAPS AND COVERS, 4s. 6d. EACH.  
 SINKER PIPES AND SYPHONS FOR CROSSING CANALS, RIVERS, Etc.

GEORGE BOWER, ST. NEOTS, HUNTINGDONSHIRE.

[SECTION N.] WROUGHT-IRON TUBES AND FITTINGS.

(Page 111 of Catalogue.)

| Inside Diameter in inches.       | ½  |    | ¾  |    | 1  |    | 1¼ |    | 1½ |    | 1¾ |    | 2  |    | 2½ |    | 3  |    |    |    |   |   |    |   |    |   |    |   |
|----------------------------------|----|----|----|----|----|----|----|----|----|----|----|----|----|----|----|----|----|----|----|----|---|---|----|---|----|---|----|---|
|                                  | s. | d. | s. | d. | s. | d. | s. | d. | s. | d. | s. | d. | s. | d. | s. | d. | s. | d. | s. | d. |   |   |    |   |    |   |    |   |
| Tubes, from 2 to 14 ft. per foot | 0  | 2½ | 0  | 3  | 0  | 3½ | 0  | 4½ | 0  | 6  | 0  | 8  | 0  | 11 | 1  | 2  | 1  | 6  | 1  | 9  | 2 | 6 | 3  | 3 | 4  | 0 | 4  | 6 |
| "    12 to 23½ in. each          | 0  | 4  | 0  | 5  | 0  | 7  | 0  | 9  | 1  | 0  | 1  | 4  | 1  | 8  | 2  | 0  | 2  | 6  | 3  | 0  | 4 | 6 | 6  | 3 | 7  | 6 | 9  | 0 |
| "    3 to 11½ in.    "           | 0  | 2  | 0  | 3  | 0  | 4  | 0  | 6  | 0  | 8  | 0  | 11 | 1  | 1  | 1  | 4  | 2  | 0  | 2  | 3  | 4 | 0 | 4  | 9 | 6  | 0 | 7  | 0 |
| Connecting Tube, 12 to 23½ in. " | 0  | 5  | 0  | 7  | 0  | 9  | 0  | 11 | 1  | 2  | 1  | 6  | 2  | 0  | 2  | 6  | 3  | 3  | 4  | 0  | 5 | 6 | 7  | 0 | 8  | 6 | 10 | 0 |
| "    3 to 11½ in.    "           | 0  | 4  | 0  | 5  | 0  | 6  | 0  | 8  | 0  | 10 | 1  | 0  | 1  | 3  | 2  | 0  | 2  | 6  | 3  | 0  | 4 | 6 | 5  | 6 | 6  | 6 | 7  | 6 |
| Tubular Bends and Lamp Bends "   | 0  | 5½ | 0  | 6½ | 0  | 7  | 0  | 8  | 0  | 11 | 1  | 3  | 1  | 9  | 2  | 3  | 3  | 3  | 4  | 3  | 6 | 6 | 10 | 0 | 12 | 0 | 16 | 0 |
| Springs, various elevations "    | 0  | 4  | 0  | 5  | 0  | 6  | 0  | 7  | 0  | 9  | 0  | 11 | 1  | 4  | 1  | 8  | 2  | 6  | 3  | 3  | 5 | 6 | 7  | 6 | 10 | 0 | 12 | 0 |

FITTINGS.

|                                      | s. | d. | s. | d. | s. | d. | s. | d. | s. | d. | s. | d. | s. | d. | s. | d. | s. | d. | s. | d. | s. | d. | s. | d. |    |    |    |    |
|--------------------------------------|----|----|----|----|----|----|----|----|----|----|----|----|----|----|----|----|----|----|----|----|----|----|----|----|----|----|----|----|
| Socket or Pipe Union, wt. iron, each | .. | 2  | 0  | 2  | 6  | 3  | 0  | 4  | 0  | 5  | 6  | 6  | 9  | 8  | 0  | 9  | 0  | 10 | 0  | 12 | 0  | 14 | 0  | 16 | 0  | 18 | 0  |    |
| Elbows, Equal or Diminished          | 0  | 6  | 0  | 6  | 0  | 7  | 0  | 8  | 0  | 10 | 1  | 2  | 1  | 9  | 2  | 3  | 3  | 0  | 3  | 6  | 5  | 6  | 8  | 6  | 11 | 0  | 14 | 0  |
| Tees " " "                           | 0  | 6  | 0  | 6  | 0  | 7  | 0  | 9  | 1  | 0  | 1  | 3  | 1  | 9  | 2  | 6  | 3  | 0  | 3  | 9  | 6  | 0  | 9  | 6  | 12 | 6  | 16 | 6  |
| Crosses " " "                        | 0  | 10 | 1  | 0  | 1  | 0  | 1  | 5  | 1  | 9  | 2  | 3  | 3  | 0  | 3  | 6  | 4  | 6  | 5  | 3  | 10 | 6  | 16 | 0  | 21 | 0  | 30 | 0  |
| Sockets, Plain " "                   | 0  | 1½ | 0  | 1½ | 0  | 2  | 0  | 3  | 0  | 3½ | 0  | 4  | 0  | 6  | 0  | 7  | 0  | 9  | 1  | 0  | 1  | 6  | 2  | 6  | 3  | 0  | 3  | 6  |
| "    Diminished . " "                | .. | 0  | 3  | 0  | 4  | 0  | 5  | 0  | 6  | 0  | 7  | 0  | 9  | 0  | 11 | 1  | 1  | 1  | 3  | 2  | 0  | 3  | 0  | 4  | 0  | 5  | 0  |    |
| Flanges " " "                        | 0  | 8  | 0  | 9  | 0  | 10 | 1  | 0  | 1  | 2  | 1  | 4  | 1  | 6  | 1  | 9  | 2  | 0  | 2  | 6  | 3  | 9  | 5  | 0  | 6  | 9  | 8  | 6  |
| Caps and Plugs " "                   | 0  | 2  | 0  | 3  | 0  | 3  | 0  | 4  | 0  | 5  | 0  | 6  | 0  | 8  | 0  | 10 | 1  | 0  | 1  | 3  | 2  | 0  | 2  | 6  | 3  | 6  | 4  | 9  |
| Backnuts and Nipples " "             | 0  | 1  | 0  | 2  | 0  | 2  | 0  | 3  | 0  | 3½ | 0  | 4  | 0  | 6  | 0  | 8  | 0  | 10 | 1  | 0  | 1  | 9  | 2  | 3  | 3  | 0  | 3  | 6  |
| Union Bends, or Elbows " "           | .. | 2  | 6  | 3  | 0  | 3  | 9  | 5  | 0  | 6  | 3  | 8  | 6  | 10 | 0  | 11 | 6  | 13 | 6  | 16 | 0  | 19 | 0  | 22 | 0  | 25 | 0  |    |
| Elbows, Round Backed, wt. iron "     | 0  | 7  | 0  | 7  | 0  | 8  | 0  | 9  | 1  | 0  | 1  | 4  | 1  | 11 | 2  | 6  | 3  | 4  | 3  | 10 | 6  | 6  | 10 | 0  | 13 | 0  | 16 | 0  |
| Iron Main Cocks " "                  | 2  | 3  | 2  | 3  | 2  | 9  | 3  | 6  | 4  | 6  | 6  | 6  | 8  | 6  | 11 | 0  | 14 | 0  | 18 | 0  | 27 | 0  | 36 | 0  | 44 | 0  | 50 | 0  |
| "    with brass Plugs " "            | .. | .. | .. | .. | .. | .. | .. | .. | .. | .. | .. | .. | .. | .. | .. | .. | .. | .. | .. | .. | .. | .. | .. | .. | .. | .. | .. | .. |
| Gas Hooks, per gross " "             | 1  | 0  | 1  | 0  | 1  | 3  | 1  | 3  | 2  | 0  | 3  | 0  | 4  | 0  | 4  | 6  | 5  | 3  | 6  | 0  | 8  | 6  | 11 | 0  | 14 | 0  | 17 | 0  |

PRICES OF SUNDRY FITTINGS FOR IRON SERVICES.

| Internal Diameter of Tube.            | ½   |    | ¾   |    | 1   |    | 1¼  |    | 1½  |    | 1¾  |    | 2   |    | 2½  |     | 3   |    |    |    |    |    |    |    |    |    |    |   |
|---------------------------------------|-----|----|-----|----|-----|----|-----|----|-----|----|-----|----|-----|----|-----|-----|-----|----|----|----|----|----|----|----|----|----|----|---|
|                                       | in. | s. | in. | s. | in. | s. | in. | s. | in. | s. | in. | s. | in. | s. | in. | s.  | in. | s. |    |    |    |    |    |    |    |    |    |   |
| Spanners for cocks . each             | ..  | .. | 0   | 6  | 0   | 7  | 0   | 8  | 0   | 9  | 0   | 11 | 1   | 2  | 1   | 4   | 1   | 6  | 1  | 9  | 2  | 0  | 2  | 3  | 2  | 6  |    |   |
| Pipe tongs or nippers per pair        | 1   | 8  | 1   | 8  | 1   | 8  | 2   | 0  | 2   | 3  | 2   | 0  | 3   | 2  | 4   | 0   | 4   | 4  | 4  | 8  | 6  | 0  | 7  | 6  | 8  | 3  | 9  |   |
| Syphon boxes for services 1 qt., each | ..  | .. | ..  | .. | 4   | 6  | 4   | 9  | 5   | 0  | 5   | 3  | 5   | 6  | 5   | 9   | 6   | 0  | .. | .. | .. | .. | .. | .. | .. | .. |    |   |
| Ditto " " 2 " "                       | ..  | .. | ..  | .. | 6   | 0  | 6   | 6  | 7   | 0  | 7   | 3  | 7   | 6  | 7   | 9   | 8   | 0  | .. | .. | .. | .. | .. | .. | .. | .. |    |   |
| Ditto " " 3 " "                       | ..  | .. | ..  | .. | ..  | .. | ..  | .. | ..  | .. | ..  | .. | ..  | .. | ..  | ..  | ..  | .. | .. | .. | .. | .. | .. | .. | .. | .. |    |   |
| Flanges " " "                         | 0   | 5  | 0   | 5  | 0   | 5  | 0   | 6  | 0   | 7  | 0   | 8  | 0   | 9  | 0   | 10½ | 1   | 0  | 1  | 0  | 10 | 0  | 11 | 3  | 12 | 9  | 14 | 6 |

PRICES OF SCREWING STOCKS, TAPS, AND DIES, ETC.

|                                                             | No. 1 Set. |      |      | No. 2 Set. |      |      | No. 3 Set. |      |     | No. 4 Set. |     |     |
|-------------------------------------------------------------|------------|------|------|------------|------|------|------------|------|-----|------------|-----|-----|
|                                                             | in.        | in.  | in.  | in.        | in.  | in.  | in.        | in.  | in. | in.        | in. | in. |
|                                                             | 3          | 2½   | 2½   | 2          | 1½   | 1½   | 1          | ¾    | ¾   | ¾          | ¾   | ¾   |
| Stocks, with 3 pairs of taps and dies, } per set            | £          | s.   | d.   | £          | s.   | d.   | £          | s.   | d.  | £          | s.  | d.  |
|                                                             | 21         | 0    | 0    | 8          | 0    | 0    | 3          | 3    | 0   | 1          | 7   | 0   |
| Dies . . . . . per pair                                     | 28/-       | 22/- | 18/- | 15/-       | 11/- | 8/-  | 6/6        | 5/-  | 4/- | 3/6        | 3/- | 3/- |
| Taps . . . . . per pair                                     | 100/-      | 70/- | 55/- | 40/-       | 20/- | 16/- | 12/-       | 10/- | 6/9 | 5/6        | 4/6 | 3/6 |
| Tap wrenches . . . . . each                                 | £          | s.   | d.   | £          | s.   | d.   | £          | s.   | d.  | £          | s.  | d.  |
|                                                             | 2          | 16   | 0    | 1          | 14   | 0    | 0          | 16   | 0   | 0          | 10  | 0   |
| Rymers, hexagon or octagon . . .                            | 25/6       | 17/6 | 14/- | 12/9       | 9/-  | 7/6  | 7/-        | 5/6  | 4/6 | 3/6        | 2/9 | 2/6 |
| Stocks, taps, and dies for ¾, ½, and ⅜ brass } tube per set | 30s.       |      |      |            |      |      |            |      |     |            |     |     |

For Prices of other Tools, see SECTION S.

[SECTION O.] STREET LAMPS, COLUMNS, AND BRACKETS.  
(Page 115 of Catalogue.) CAST-IRON LAMP COLUMNS.

| Number of Column. | 1       | 2         | 3        | 3a        | 4        | 5         | 6        | 7         | 8        | 9         | 10       | 11       | 12   |          |
|-------------------|---------|-----------|----------|-----------|----------|-----------|----------|-----------|----------|-----------|----------|----------|------|----------|
| Prices            | £ 3 0 0 | s. d. 0 0 | £ 1 15 0 | s. d. 0 0 | £ 2 15 0 | s. d. 0 2 | £ 1 10 0 | s. d. 0 1 | £ 1 15 0 | s. d. 0 2 | £ 2 17 6 | s. d. .. | £ .. | s. d. .. |

CAST-IRON LAMP BRACKETS.

| Number of Bracket. | 31      | 32           | 33       | 34          | 35      | 36          | 37      |              |
|--------------------|---------|--------------|----------|-------------|---------|-------------|---------|--------------|
| Prices             | £ 1 5 0 | s. d. 0 13 0 | £ 0 16 0 | s. d. 1 0 0 | £ 1 0 0 | s. d. 1 0 0 | £ 1 5 0 | s. d. 0 15 0 |

LANTERNS, PAINTED AND GLAZED.

| Size of Lanterns in Inches.                                                                             | 13       | 14           | 16       | 18           |
|---------------------------------------------------------------------------------------------------------|----------|--------------|----------|--------------|
| No. 14. HEXAGON LANTERN, with Tin Frame, Glass Side Door, and Opening in Bottom to admit Lighting Torch | £ 0 13 0 | s. d. 0 15 0 | £ 0 18 0 | s. d. 1 2 0  |
| " " Ditto, Copper Frame, ditto                                                                          | £ 1 12 0 | s. d. 1 16 0 | £ 2 2 0  | s. d. 2 10 0 |
| " 15. SQUARE LANTERN, with ditto                                                                        | £ 0 12 0 | s. d. 0 13 0 | £ 0 16 0 | s. d. 1 0 0  |
| " " Ditto Copper ditto                                                                                  | £ 1 5 0  | s. d. 1 10 0 | £ 1 15 0 | s. d. 2 0 0  |
| " 33. ORNAMENTAL HEXAGON LANTERN, with Copper Frame Side Door, and Opening in Bottom                    | £ 3 5 0  | s. d. 3 10 0 | £ 3 15 0 | s. d. 4 0 0  |
| " 17. GLOBE LANTERN, with Iron Frame, Glass, and Door                                                   | £ 2 5 0  | s. d. 2 10 0 | £ 2 15 0 | s. d. ..     |
| " 31. Ditto Ditto                                                                                       | £ 2 0 0  | s. d. 2 5 0  | £ 2 10 0 | s. d. ..     |
| " 34. Ditto Ditto                                                                                       | £ 1 10 0 | s. d. 1 15 0 | £ 2 0 0  | s. d. ..     |
| " 35. Ditto Ditto                                                                                       | £ 1 10 0 | s. d. 1 15 0 | £ 2 0 0  | s. d. ..     |
| " 39. SQUARE Ditto Ditto, Glass, and Opening                                                            | £ 1 10 0 | s. d. 1 15 0 | £ 2 0 0  | s. d. ..     |
| " 40. HEXAGON SHADOWLESS Ditto, with Spike Top and Glass, complete                                      | £ 0 12 0 | s. d. 0 14 0 | £ 0 16 0 | s. d. ..     |
| " " Ditto, with Crown Top                                                                               | £ 0 14 0 | s. d. 0 16 0 | £ 0 18 0 | s. d. ..     |
| " 16. GLASS LANTERN, with Ornamental Cap and Base                                                       | £ 1 5 0  | s. d. 1 14 0 | £ ..     | s. d. ..     |

|                                                                                              |                  |            |
|----------------------------------------------------------------------------------------------|------------------|------------|
| CARRIERS for STREET COLUMNS, with Wrought-iron Ladder Bars                                   | s. d. 3 6        | each.      |
| " BRACKETS and COLUMNS, without Ladder Bars                                                  | s. d. 2 6        | "          |
| LEVER LANTERN COCKS, with Tube and Burner for ditto, single                                  | s. d. 3 0        | "          |
| " " " " " " double                                                                           | s. d. 3 6        | "          |
| " " " " " " Regulator                                                                        | s. d. 6 6        | "          |
| TORCHES, for Lighting Lanterns                                                               | s. d. 5 0        | "          |
| ENAMELLED IRON DEFLECTOR PLATES, for top portion of No. 40 Cast-iron Lanterns, price per Set | s. d. 13 in. 3 6 | 14 in. 4 6 |
| Duplicate Sets of Glass for ditto, price per Set                                             | s. d. 2 6        | 3 6        |

[SECTION P.] CONSUMERS' METERS, ETC.  
(Page 123 of Catalogue.) WET METERS IN CAST-IRON CASES.

| Number of lights will supply. | 2       | 3            | 5        | 10           | 20       | 30           | 50       | 80            | 100      | 200           |
|-------------------------------|---------|--------------|----------|--------------|----------|--------------|----------|---------------|----------|---------------|
| Price of each Meter           | £ 1 8 0 | s. d. 1 13 6 | £ 2 10 0 | s. d. 3 17 6 | £ 5 16 6 | s. d. 8 18 0 | £ 13 6 6 | s. d. 18 18 0 | £ 22 5 0 | s. d. 37 16 3 |

COMPENSATING WET METERS.

| Number of lights will supply. | 2        | 3            | 5        | 10          | 20      | 30           | 50       | 80            | 100       | 200           |
|-------------------------------|----------|--------------|----------|-------------|---------|--------------|----------|---------------|-----------|---------------|
| Price of each Meter           | £ 1 11 0 | s. d. 1 17 0 | £ 2 15 0 | s. d. 4 5 0 | £ 6 8 0 | s. d. 9 18 0 | £ 15 5 0 | s. d. 20 18 0 | £ 24 10 0 | s. d. 41 14 0 |

DRY METERS IN TIN-PLATE CASES.

| Number of lights will supply.     | 1          | 2            | 3           | 5            | 10        | 20        | 30        | 50       | 60         | 80         | 100           | 150       | 200        | 250       | 300       | 400       | 500        |
|-----------------------------------|------------|--------------|-------------|--------------|-----------|-----------|-----------|----------|------------|------------|---------------|-----------|------------|-----------|-----------|-----------|------------|
| Price of each Meter               | £ s. 1 11  | £ s. 1 17    | £ s. 2 5    | £ s. 2 15    | £ s. 3 11 | £ s. 4 18 | £ s. 6 15 | £ s. 9 8 | £ s. 12 12 | £ s. 15 18 | £ s. 20 13    | £ s. 28 6 | £ s. 37 16 | £ s. 43 3 | £ s. 51 8 | £ s. 66 0 | £ s. 82 10 |
| Testing and Stamping Meters Price | 1 to 5 6d. | 10 to 30 1/- | 50 & 60 2/- | 80 & 100 3/- | 150 5/-   | 200 6/-   | 250 7/-   | 300 9/-  | 400 13/-   | 500 15/-   | Lights. Each. |           |            |           |           |           |            |

EXPERIMENTAL OR TEST METERS.

| Number of Lights will supply. | 3             | 5             | 10             | 20             |
|-------------------------------|---------------|---------------|----------------|----------------|
| Price of each Meter           | £ s. d. 5 5 0 | £ s. d. 6 0 0 | £ s. d. 7 10 0 | £ s. d. 10 0 0 |

TEST GASHOLDERS.

| Capacity in Cubic Feet. | 1              | 5              | 10             | 20             |
|-------------------------|----------------|----------------|----------------|----------------|
| Price of each           | £ s. d. 12 0 0 | £ s. d. 18 0 0 | £ s. d. 22 0 0 | £ s. d. 28 0 0 |

Minute Clocks . . . . . from £5 5s. each.

[SECTION P.]

GAS REGULATORS.

(Page 126 of Catalogue.)

| Number of Lights will regulate | 2         | 3        | 5        | 10        | 20       | 50       | 80        | 100      |
|--------------------------------|-----------|----------|----------|-----------|----------|----------|-----------|----------|
| Price of each                  | £ s. 0 18 | £ s. 1 0 | £ s. 1 5 | £ s. 1 10 | £ s. 2 0 | £ s. 3 0 | £ s. 3 10 | £ s. 6 0 |

[SECTION Q.]

GAS FITTINGS.

(Page 127 of Catalogue.)

ILLUSTRATIONS AND PRICES OF EVERY DESCRIPTION OF GASELIERS, PENDANTS, BRACKETS, HALL AND PASSAGE LAMPS, SUN LIGHTS, IN MEDIEVAL OR ANY VARIETY OF STYLE, SUITABLE FOR CHURCHES, PUBLIC BUILDINGS, MUSEUMS AND OFFICES, MAY BE HAD ON APPLICATION.

- GAS STANDS WITH FLEXIBLE TUBE.
- GAS SHADES OR MOONS.
- GAS REFLECTORS.
- ILLUMINATION DEVICES.

- APPARATUS FOR TESTING THE SOUNDNESS OF GAS FITTINGS.
- BAMBOO RODS AND TORCHES.
- FLEXIBLE TUBING, PLAIN AND GLAZED.
- WOOD BLOCKS OR PATRESSES.

(Page 128 of Catalogue.)

CARTERS' VALVES.

| Size in Inches. | ½         | ¾         | 1         | 1½        | 1¾         | 2          |
|-----------------|-----------|-----------|-----------|-----------|------------|------------|
| Price of each   | s. d. 3 0 | s. d. 3 6 | s. d. 4 6 | s. d. 9 0 | s. d. 11 0 | s. d. 21 0 |

(Page 129 of Catalogue.)

PATENT GAS BURNERS.

|                                                                                                       |                |
|-------------------------------------------------------------------------------------------------------|----------------|
| BAT'S-WING, UNION JET, OR FISHTAIL BURNERS, with Taper Screws or Plug Sockets, up to No. 8, per gross | £ s. d. 0 12 0 |
| UNION JETS, in Brass Sockets                                                                          | 0 12 0         |
| BAT'S-WING ECONOMISERS, to No. 8                                                                      | 1 7 0          |
| UNION JET " all sizes                                                                                 | 1 2 6          |
| BRITISH STANDARD BURNERS, complete with triangles, each                                               | 0 1 6          |
| " " " " without                                                                                       | 0 1 0          |
| BAT'S-WING AND UNION JET BURNERS, in Steatite per gross                                               | 0 12 0         |
| BRASS BURNERS                                                                                         | 0 18 0         |

EVERY VARIETY OF ARGAND, RING, SPRAY, SUN, OR AIR BURNERS.



[SECTION R.] GAS HEATING AND COOKING STOVES.

(Page 131 of Catalogue.)

|                        |      |   |    |   |                            |                 |      |    |   |    |   |
|------------------------|------|---|----|---|----------------------------|-----------------|------|----|---|----|---|
| BOILING STOVE, No. 1   | each | £ | 0  | 5 | 6                          | BACHELOR'S OVEN | each | £  | 1 | 15 | 0 |
| " " " 2                | "    | 0 | 6  | 6 | PATENT BOILERS, No. 1      | "               | 0    | 9  | 0 |    |   |
| " " " 3                | "    | 0 | 8  | 6 | " " " 2                    | "               | 0    | 12 | 0 |    |   |
| ETNAS " " 4            | "    | 0 | 9  | 0 | " " " 3                    | "               | 0    | 15 | 0 |    |   |
| " " " 1                | "    | 0 | 9  | 0 | STEWING APPARATUS          | "               | 0    | 18 | 0 |    |   |
| " " " 2                | "    | 0 | 14 | 0 | CYLINDRICAL COOKING STOVES | "               | 1    | 10 | 0 |    |   |
| (Pages 132 and 133.)   |      |   |    |   |                            |                 |      |    |   |    |   |
| COOKING STOVE A        | each | 3 | 15 | 0 | COOKING STOVE E            | each            | 14   | 0  | 0 |    |   |
| " " B                  | "    | 5 | 12 | 6 | " " F                      | "               | 28   | 0  | 0 |    |   |
| " " C                  | "    | 7 | 10 | 0 | " " No. 100                | "               | 3    | 5  | 0 |    |   |
| " " D                  | "    | 9 | 15 | 0 | " " " 104                  | "               | 9    | 7  | 6 |    |   |
| (Pages 134 and 135.)   |      |   |    |   |                            |                 |      |    |   |    |   |
| HEATING STOVES, No. 00 | each | 2 | 7  | 0 | HEATING STOVES, No. 34     | each            | 2    | 16 | 0 |    |   |
| " " 20                 | "    | 0 | 18 | 0 | " " 35                     | "               | 1    | 11 | 0 |    |   |
| " " 21                 | "    | 9 | 7  | 6 | " " 36                     | "               | 0    | 18 | 0 |    |   |
| " " 23                 | "    | 1 | 8  | 0 | " " 37                     | "               | 2    | 16 | 0 |    |   |
| " " 24                 | "    | 1 | 10 | 0 | " " 38                     | "               | 2    | 16 | 0 |    |   |
| " " 25                 | "    | 1 | 10 | 0 |                            |                 |      |    |   |    |   |

[SECTION S.] SUNDRY TOOLS AND IMPLEMENTS.

(Page 137 of Catalogue.)

PORTABLE FORGES.

|                                                     |   |   |    |   |
|-----------------------------------------------------|---|---|----|---|
| No. 1. 20 in. diam. and 28 in. high, 18 in. bellows | £ | 4 | 10 | 0 |
| " 2. 24 " 28 " 22 "                                 | £ | 6 | 10 | 0 |
| " 3. 22 " 32 " cased with iron                      | £ | 5 | 10 | 0 |
| " 4. 24 " 34 " " "                                  | £ | 9 | 0  | 0 |

RIVET FORGES.

|                 |   |   |    |   |
|-----------------|---|---|----|---|
| 18 in. Circular | £ | 3 | 0  | 0 |
| 20 " "          | £ | 3 | 10 | 0 |
| 22 " "          | £ | 4 | 0  | 0 |

SMITHS' BELLOWS.

| Sizes. | in. 20 | in. 22 | in. 24 | in. 26 | in. 28 | in. 30 | in. 32 | in. 34 | in. 36 | in. 38 | in. 40  |
|--------|--------|--------|--------|--------|--------|--------|--------|--------|--------|--------|---------|
| Prices | £ 2 2  | £ 2 10 | £ 3 0  | £ 3 12 | £ 4 4  | £ 5 0  | £ 6 0  | £ 7 10 | £ 9 14 | £ 12 5 | £ 15 10 |

WATER TUYERES.

| Sizes. | in. 12 | in. 13 | in. 14 | in. 15 | in. 16 |
|--------|--------|--------|--------|--------|--------|
| Prices | £ 1 0  | £ 1 1  | £ 1 2  | £ 1 4  | £ 1 6  |

|                                              |   |    |    |   |          |
|----------------------------------------------|---|----|----|---|----------|
| BEST WARRANTED ANVILS                        | £ | 1  | 10 | 0 | per cwt. |
| " " " with 2 Beaks                           | £ | 1  | 12 | 0 | "        |
| CAST-IRON HEARTH FRAMES, with Hood complete  | £ | 13 | 0  | 0 |          |
| ENGINEERS' HAMMERS, 1½ lbs. and upwards      | £ | 0  | 1  | 6 | per lb.  |
| " " " cast steel                             | £ | 0  | 2  | 0 | "        |
| SLEDGR HAMMERS, 5 to 20 lbs.                 | £ | 0  | 1  | 0 | "        |
| CAST-STEEL CHISELS, Cross-cuts, Points, etc. | £ | 0  | 1  | 3 | "        |

|                                           |   |    |    |    |          |
|-------------------------------------------|---|----|----|----|----------|
| CAST-STEEL CAULKING TOOLS                 | £ | 0  | 2  | 0  | per lb.  |
| IRON WARRANTED BRIGHT VICES               | £ | 0  | 0  | 9  | "        |
| " " " BLACK " "                           | £ | 0  | 0  | 5  | "        |
| PARALLEL VICES, 4 to 10 in. jaws, from    | £ | 3  | 10 | s. | to 7 0 0 |
| ADJUSTABLE VICES                          | £ | 2  | 10 | 0  | each     |
| DRILLING MACHINE, BENCH AND VICE complete | £ | 12 | 0  | 0  | "        |

DOUBLE ENDED SPANNERS.

| Span. | in. ½ to ¾ | in. ¾ to 1 | in. 1 to 1¼ | in. 1¼ to 1½ | in. 1½ to 1¾ | in. 1¾ to 2 |
|-------|------------|------------|-------------|--------------|--------------|-------------|
| Price | £ 2 3      | £ 4 2      | £ 6 6       | £ 7 6        | £ 8 6        | £ 10 0      |

SINGLE ENDED SPANNERS.

| Span. | in. ½ | in. ¾ | in. 1 | in. 1¼ | in. 1½ | in. 1¾    |
|-------|-------|-------|-------|--------|--------|-----------|
| Price | £ 0 9 | £ 1 2 | £ 2 3 | £ 3 0  | £ 4 0  | £ 5 0 6 0 |

SELF-ADJUSTING SPANNERS.

| Number. | 1      | 2       | 3       | 4        |
|---------|--------|---------|---------|----------|
| Length  | in. 8  | in. 10  | in. 14  | in. 18   |
| Span    | ½ to 1 | ¾ to 1½ | 1 to 1¾ | 1½ to 2½ |
| Price   | £ 6 6  | £ 9 0   | £ 12 0  | £ 14 6   |

ADJUSTABLE SCREW KEYS, OF BEST CONSTRUCTION.

| Length in inches. | 6     | 8     | 10     | 12     | 14     | 16     | 18     | 20     | 22     |
|-------------------|-------|-------|--------|--------|--------|--------|--------|--------|--------|
| Price             | £ 7 6 | £ 9 0 | £ 10 6 | £ 12 9 | £ 15 0 | £ 16 8 | £ 18 0 | £ 20 6 | £ 22 3 |

|             |   |   |    |   |          |
|-------------|---|---|----|---|----------|
| STONE PICKS | £ | 2 | 0  | 0 | per cwt. |
| MATTOCKS    | £ | 2 | 6  | 0 | "        |
| PICK AXES   | £ | 1 | 12 | 0 | "        |

FILES AND RASPS AT THE "SHEFFIELD LIST" PRICES.

RACHET BRACES.

| Length in inches | 12       | 14      | 16      | 18       | 20       | 22       | 24       |
|------------------|----------|---------|---------|----------|----------|----------|----------|
| Price, each      | £ 0 18 0 | £ 1 2 6 | £ 1 6 6 | £ 1 10 0 | £ 1 14 0 | £ 1 16 0 | £ 1 19 0 |

BENCH DRILLING MACHINE.

Height, 16 in.  
Length of arm, 14 in. } Price, £2 17 0

DRILLING PILLAR BRACE, ETC., complete each 2 12 0  
CRAMP AND BRACE FOR DRILLING MAINS, £2 5s. to 2 10 0

NO. 1. IMPERIAL TUBE VICE, to hold any pipe from 1/2 to 2 in. £ 1 15 0  
NO. 2. Small size " Large, ditto " " " " £ 1 5 0

PATENT ROLLING TUBE CUTTER, No. 1.  
To cut from 1/4 to 1 1 1/4 to 2 2 to 3 ins.  
Price 13/6 22/6 33/9

TUBE PLIERS, TWO HOLES.  
Length 7 8 9 10 11 12 14 15 ins.  
Price per doz. 15/- 18/- 21/- 24/6 28/6 32/- 39/- 46/-

PATENT ROLLING TUBE CUTTER. No. 2.  
To cut 1 2 4 ins.  
Price each 19s. 6d. £1 8s. 0d. £3 0s. 0d.  
Extra Cutter " 1s. 8d. 2s. 2d. 2s. 6d.

TUBE PLIERS, BRIGHT.  
Length 6 7 ins.  
Price per dozen 15s. 0d. 18s. 0d.

WESTON'S PATENT DIFFERENTIAL PULLEY BLOCKS.

| Tested to               | 5          | 10          | 12          | 20         | 30          | 40         | 60          | 80 cwt.     |
|-------------------------|------------|-------------|-------------|------------|-------------|------------|-------------|-------------|
| Prices                  | £1 0s. 0d. | £1 10s. 0d. | £1 10s. 0d. | £2 0s. 0d. | £2 15s. 0d. | £3 5s. 0d. | £6 10s. 0d. | £7 16s. 0d. |
| Bright Chains, per foot | 0 0 6      | 0 0 6       | 0 0 7       | 0 0 9      | 0 0 10      | 0 0 11     | 0 1 1       | 0 1 3       |

PULLEY BLOCKS.

| Diameter of Sheaves in inches. | 4       | 5        | 6        | 7        | 8        |
|--------------------------------|---------|----------|----------|----------|----------|
| Price with 1 Sheave            | £ 0 5 9 | £ 0 10 0 | £ 0 11 6 | £ 0 14 0 | £ 0 19 0 |
| " 2 Sheaves                    | 0 8 6   | 0 15 6   | 0 17 0   | 1 4 6    | 1 15 6   |
| " 3 "                          | 0 10 6  | 0 19 6   | 1 1 6    | 1 10 6   | 2 8 6    |
| " 4 "                          | 0 12 6  | 1 5 6    | 1 8 6    | 2 6 0    | 3 3 0    |

DOUBLE PURCHASE HOISTING CRAB.

| To Lift       | 2           | 3           | 4           | 6           | 8           | 10           | 12          | 16 tons.    |
|---------------|-------------|-------------|-------------|-------------|-------------|--------------|-------------|-------------|
| With Brake    | £5 12s. 6d. | £6 10s. 0d. | £7 12s. 6d. | £8 10s. 0d. | £10 2s. 6d. | £13 10s. 0d. | £17 0s. 0d. | £20 5s. 0d. |
| Without ditto | 4 10 0      | 5 5 0       | 6 5 0       | 7 0 0       | 8 10 0      | 11 15 0      | 15 3 0      | 18 0 0      |

If Brass-Bushed, 2 to 6 tons £1 5s. 6d., 6 to 8 tons £1 10s., 10 to 16 tons £1 15s. extra.

SINGLE PURCHASE CRABS.

| To Lift       | 1           | 1 1/2       | 2           | 3          | 4          | 6          | tons. |
|---------------|-------------|-------------|-------------|------------|------------|------------|-------|
| With Brake    | £2 10s. 0d. | £2 15s. 0d. | £3 10s. 0d. | £4 5s. 0d. | £5 5s. 0d. | £6 0s. 0d. |       |
| Without ditto | 3 10 0      | 3 17 6      | 4 12 6      | 5 10 0     | 6 12 6     | 7 10 0     |       |

If Brass-Bushed, £1 2s. 6d. extra.

PATENT HYDRAULIC JACK.

| To Lift | 4          | 6          | 8          | 10          | 12          | 15          | 20          | tons. |
|---------|------------|------------|------------|-------------|-------------|-------------|-------------|-------|
| Price   | £5 0s. 8d. | £6 8s. 0d. | £7 6s. 0d. | £8 11s. 0d. | £9 12s. 0d. | £11 4s. 0d. | £13 7s. 0d. |       |

PUNCH, WITH BED AND PUNCHES.

For 1/2, 3/8, and 1/2 inch.  
Price £1 15s. 0d.

HYDRAULIC PUNCH.

No. 1. To Punch 3/4 inch in 1/2 inch Plate £11 5s. 0d.  
" 2. " 1 " " 1/2 " " 16 17 6

PUNCHING BEAR OF CAST STEEL.

| No. 1               | No. 2      | No. 3       |
|---------------------|------------|-------------|
| £2 13s. 4d.         | £3 4s. 0d. | £4 5s. 6d.  |
| Ratchet Lever extra | -          | £1 12s. 0d. |
| Plain ditto         | -          | 0 4 9       |

Extra Punches and Dies, 10s. 8d. per pair.

PUNCHING BEAR AND LEVER, WITH THREE BEDS AND PUNCHES.

| 3/8                       | 1/2        | 5/8        | 1 inch.             |
|---------------------------|------------|------------|---------------------|
| Price £4 8s. 0d.          | £5 0s. 0d. | £6 0s. 0d. | £6 18s. 0d.         |
| With Ratchet Lever        | -          | -          | £1 10s. each extra. |
| Hand Cramps or Screw Dogs | -          | -          | 0 14 each.          |

PUNCHING AND SHEARING MACHINES.

PORTABLE HAND MACHINES.

PUNCHING MACHINES, WITH FLY-WHEELS.

GRINDSTONES AND TROUGHS COMPLETE.

| Diameter of Stones | 12 | 15     | 18      | 24     | 36      | 48     | inches. |
|--------------------|----|--------|---------|--------|---------|--------|---------|
| Prices             | -  | £2 4s. | £2 10s. | £3 3s. | £3 15s. | £5 7s. | £7 10s. |

CIRCULAR SAW BENCHES,

Fitted with 24-in. Saw, £22. Larger Size, with Self-Acting Feed, £30.

IRON BED LATHE. No. 1.

| Height to Centre. | Length of Iron Bed. | Single Collars. | Double Collars. | Slide Rest extra. |
|-------------------|---------------------|-----------------|-----------------|-------------------|
| in. 3½            | ft. 2 6             | £ 8 0           | £ 9 10          | £ 5 0             |
| 4                 | 3 0                 | 10 0            | 11 10           | 6 5               |
| 5                 | 4 0                 | 13 0            | 15 0            | 7 10              |
| 6                 | 5 0                 | 15 15           | 18 0            | 8 15              |
| 7                 | 7 0                 | 22 0            | 24 10           | 10 0              |

IRON BED LATHE. No. 2.

| Height to Centre. | Length of Iron Bed. | Single Collars. | Double Collar & Back Gear. | Slide Rest extra. | Screen Cutter. |
|-------------------|---------------------|-----------------|----------------------------|-------------------|----------------|
| in. 4             | ft. 3 0             | £ 16 0          | £ 19 0                     | £ 7 0             | £ 45 0         |
| 5                 | 4 0                 | 20 0            | 23 0                       | 9 0               | 52 0           |
| 6                 | 5 0                 | 26 0            | 30 0                       | 10 0              | 63 0           |
| 7                 | 6 0                 | 35 0            | 41 0                       | 12 0              | 81 0           |
| 8                 | 7 0                 | ....            | ....                       | 14 0              | 100 0          |

AMERICAN SELF-ADJUSTING SCROLL CHUCKS.

TO WORK BY LEVERS.

| Diameter | in. 3 | in. 4  | in. 6 | in. 9  | in. 12 | in. 15 |
|----------|-------|--------|-------|--------|--------|--------|
|          | Price | £ 1 16 | £ 2 0 | £ 3 12 | £ 4 15 | £ 6 6  |

TO WORK WITH KEY.

| Diameter | in. 3 | in. 4 | in. 5  | in. 6 | in. 9  |
|----------|-------|-------|--------|-------|--------|
|          | Price | £ 2 5 | £ 2 14 | £ 3 3 | £ 3 15 |

PATENT EMERY WHEELS.

| Diameter in in. | in. ½    | in. ⅝    | in. ¾    | in. 1   | in. 1½  | in. 2   | in. 2½  | in. 3   | in. 4   |
|-----------------|----------|----------|----------|---------|---------|---------|---------|---------|---------|
|                 | 3        | £ 0 1 00 | £ 1 2 0  | £ 1 2 0 | £ 1 6 0 | £ 2 1 0 | £ 2 8 0 | £ 3 3 0 | £ 4 5 0 |
| 4               | 0 1 2 0  | 1 6 0    | 1 9 0    | 2 5 0   | 3 7 0   | 4 6 0   | 5 9 0   | 7 0 0   | 9 0 0   |
| 6               | 0 3 0 0  | 3 7 0    | 4 4 0    | 5 4 0   | 8 1 0   | 10 10 0 | 13 6 0  | 16 2 1  | 1 6     |
| 7               | 0 3 7 0  | 4 6 0    | 5 4 0    | 7 2 0   | 10 9 0  | 14 5 0  | 18 0 1  | 1 6 1   | 8 9     |
| 8               | 0 4 9 0  | 6 0 0    | 6 10 0   | 9 0 0   | 13 6 0  | 18 0 1  | 2 6 1   | 7 0 1   | 16 0    |
| 10              | 0 7 2 0  | 9 0 0    | 10 9 0   | 14 4 1  | 1 6 1   | 8 9 1   | 16 0 2  | 3 0 2   | 17 6    |
| 12              | 0 10 9 0 | 13 6 0   | 16 3 1   | 1 6 1   | 11 4 2  | 3 0 2   | 14 0 3  | 4 9 4   | 6 4     |
| 16              | .. ..    | .. ..    | 1 7 0 1  | 16 0 2  | 14 0 3  | 12 0 4  | 10 0 5  | 8 0 7   | 4 0     |
| 18              | .. ..    | .. ..    | 1 15 0 2 | 6 9 3   | 11 9 4  | 13 6 5  | 17 0 7  | 4 0 8   | 17 0    |

BEST ENGINEER'S STOCKS AND DIES, WITH TAPS.

| Size                        | Price with Taper and Plug Tap to each size | £ | s. | d. |
|-----------------------------|--------------------------------------------|---|----|----|
| Size ¼, ⅜, ½, ⅝, ¾, 1 inch. | .. ..                                      | 1 | 17 | 0  |
| ¾, 1, 1½                    | .. ..                                      | 2 | 0  | 0  |
| 1, 1½, 2                    | .. ..                                      | 3 | 4  | 0  |
| 1½, 2, 2½                   | .. ..                                      | 4 | 14 | 0  |

APPARATUS FOR TESTING CAST-IRON PIPES BY HYDRAULIC PRESSURE.

Apparatus for Testing Cast-iron pipes by Hydraulic Pressure, to take pipes up to fifteen inches diameter, to prove up to 200 lbs. per square inch, complete with cistern, double air pump, stop valve, etc., complete, £67 10s.

The Pipe prover can be had without Cistern at £10 less; in such case it may be mounted on a wood stand, which is not included in the price.

AIR PUMP, for Testing Joints of Mains, £23 0s.

SPIRIT LEVELS.

PLUMB-BOBS.

SHEAR LEGS, FOR MAINLAYING.

WROUGHT FIRE CRATES, £2 0s. per cwt.

LEAD POTS. £1 0s. per cwt.

LADLES, 4d. per lb.

IMPROVED PATENT WEIGH-BRIDGES FOR CARTS AND WAGGONS.

WEIGH-BRIDGE FOR CARTS.

WEIGH BRIDGE FOR WAGGONS.

| To weigh | Size of Platform.                 | £  | s. | d. | To weigh | Size of Platform.        | £  | s. | d. |
|----------|-----------------------------------|----|----|----|----------|--------------------------|----|----|----|
| 3 Tons   | 4 feet 6 inches X 5 feet 6 inches | 21 | 0  | 0  | 5 Tons   | 8 feet X 6 feet 3 inches | 42 | 0  | 0  |
| 4 "      | 4 " 6 " " 6 " 0 "                 | 24 | 0  | 0  | 8 "      | 10 " 6 " 6 " "           | 54 | 0  | 0  |
| 4 "      | 4 " 6 " " 6 " 6 "                 | 25 | 0  | 0  | 10 "     | 11 " 7 " " "             | 60 | 0  | 0  |
| 4 "      | 6 " 6 " " 6 " 0 "                 | 30 | 0  | 0  | 12 "     | 12 " 7 " " "             | 66 | 0  | 0  |
| 5 "      | 6 " 6 " " 6 " 6 "                 | 33 | 0  | 0  | 12 "     | 12 " 8 " " "             | 70 | 0  | 0  |
|          |                                   |    |    |    | 15 "     | 14 " 8 " " "             | 80 | 0  | 0  |

May be had Self-Contained, or fitted with Relieving Apparatus, if required, at extra cost.

COAL WEIGHING MACHINES.

FITTED WITH STRONG IRON SCOOP TO TILT.

FOR IRON BAR WEIGHTS.

WITH STEEL-YARD.

| To weigh | £ | s. | d. | To weigh | £ | s. | d. |
|----------|---|----|----|----------|---|----|----|
| 1 cwt.   | 3 | 10 | 0  | 1 cwt.   | 4 | 0  | 0  |
| 2 "      | 4 | 5  | 0  | 1½ "     | 4 | 10 | 0  |
| 3 "      | 5 | 0  | 0  | 2 "      | 4 | 15 | 0  |

IRON BAR WEIGHTS ADJUSTED AND STAMPED.

| Weight | Price, each |
|--------|-------------|
| 56     | 7s. 0d.     |
| 28     | 4s. 6d.     |
| 14     | 3s. 6d.     |
| 7      | 2s. 0d.     |
| 4      | 1s. 4d.     |
| 1      | 6d.         |
| ½      | 4d.         |
| ¼ lb.  | 4d.         |

LEVER PLATFORM WEIGHING MACHINES.

|                    |                                                |                  |                    |                                          |                  |
|--------------------|------------------------------------------------|------------------|--------------------|------------------------------------------|------------------|
| To weigh<br>4 cwt. | Size of Platform<br>1 ft. 11 in. X 1 ft. 7 in. | £ s. d.<br>4 5 0 | To weigh<br>5 cwt. | Size of Platform<br>2 ft. X 1 ft. 11 in. | £ s. d.<br>5 5 0 |
|--------------------|------------------------------------------------|------------------|--------------------|------------------------------------------|------------------|

MAIN AND SERVICE LAYER'S TRUCKS.

Price, each £3 15s.

PORTABLE STEAM BOILERS.

1-horse Power, £25; 2-horse Power, £35; 3-horse Power £45.

TAR PUMPS.

|                   |                  |
|-------------------|------------------|
| 2½ in. bore, each | £ s. d.<br>2 0 0 |
| 3 " " "           | 2 5 0            |
| 4 " " "           | 3 0 0            |
| 5 " " "           | 4 6 0            |

LIFT AND FORCE PUMPS.

|                   |                  |
|-------------------|------------------|
| 2½ in. bore, each | £ s. d.<br>2 8 0 |
| 3 " " "           | 2 10 0           |
| 4 " " "           | 3 0 0            |
| 5 " " "           | 3 15 0           |

BRASS SYPHON PUMPS  
SWIVEL JOINTS FOR TAR AND LIQUOR SUCTION PIPES

each £ s. d.  
1 0 0  
0 18 0

WROUGHT-IRON CISTERNS, AND TANKS OF WROUGHT AND  
CAST-IRON, to special quotations.

PRINCIPALS.

IRON PRINCIPALS FOR RETORT HOUSE ROOFING—from 20 to 30 feet span, per square yard of roof surface, 10s. 6d.  
" " No. 10 "Tenders given" for any sized roofs " " 9s. 6d.

CAST-IRON WINDOW FRAMES.

|                                           |     | Height<br>ft. ins. | Width<br>ft. ins. | £ s. d. |
|-------------------------------------------|-----|--------------------|-------------------|---------|
| CAST IRON WINDOW FRAME, WITH CIRCULAR TOP |     | 6 4                | 3 7½              | 2 0 0   |
| " "                                       | " " | 4 1                | 3 7½              | 1 6 6   |
| " "                                       | " " | 5 8                | 2 5               | 1 2 6   |
| " "                                       | " " | 5 0                | 2 5               | 1 0 0   |
| " "                                       | " " | 4 3                | 2 5               | 0 16 0  |
| " "                                       | " " | 2 6                | 2 5               | 0 7 6   |
| RECTANGULAR                               |     | 4 7                | 3 7½              | 1 5 0   |
| " "                                       | " " | 4 7                | 2 5½              | 0 18 6  |
| " "                                       | " " | 3 10               | 2 5½              | 0 16 0  |
| " "                                       | " " | 3 1                | 2 5½              | 0 13 6  |
| " "                                       | " " | 3 1                | 1 10½             | 0 7 6   |
| FAN LIGHTS                                |     | 5 3                | 5 3               | 0 17 0  |
| " "                                       | " " | 4 4                | 4 4               | 0 14 0  |
| " "                                       | " " | 4 0                | 4 0               | 0 13 0  |
| " "                                       | " " | 3 7                | 3 7               | 0 12 6  |
| " "                                       | " " | 3 4                | 3 4               | 0 11 0  |
| " "                                       | " " | 2 11               | 2 11              | 0 8 0   |

[SECTION V.]

HEATING APPARATUS.

(Page 155 of Catalogue.)

SELF-CONTAINED HOT WATER BOILERS.

| Size. | Length of 4-in. Pipe each Boiler will Heat. | Price.  | Size. | Length of 4-in. Pipe each Boiler will Heat. | Price.  |
|-------|---------------------------------------------|---------|-------|---------------------------------------------|---------|
| No.   | feet.                                       | £ s. d. | No.   | feet.                                       | £ s. d. |
| 1     | 250                                         | 10 0 0  | 5     | 900                                         | 20 10 0 |
| 2     | 400                                         | 12 10 0 | 6     | 1600                                        | 25 0 0  |
| 3     | 500                                         | 13 10 0 | 7     | 2500                                        | 30 0 0  |
| 4     | 600                                         | 17 10 0 | 8     | 3500                                        | 35 0 0  |

IMPROVED SADDLE BOILERS.

NO. 1 BOILER.

| Length, Width, and Height. | Estimated Heating Power in 4-in. Pipe. | Price each. |
|----------------------------|----------------------------------------|-------------|
| inches.                    | feet.                                  | £ s. d.     |
| 24 X 19 X 30               | 1100                                   | 18 0 0      |
| 30 X 21 X 32               | 1600                                   | 22 0 0      |
| 36 X 23 X 35               | 2150                                   | 27 10 0     |
| 42 X 24 X 40               | 2700                                   | 34 10 0     |
| 48 X 26 X 40               | 3500                                   | 42 0 0      |
| 54 X 27 X 42               | 4500                                   | 50 0 0      |
| 60 X 28 X 45               | 5500                                   | 58 0 0      |
| 66 X 30 X 45               | 6500                                   | 66 0 0      |
| 72 X 32 X 45               | 7500                                   | 75 0 0      |

NO. 2 BOILER.

| Length, Width, and Height. | Estimated Heating Power in 4-in. Pipe. | Price each. |
|----------------------------|----------------------------------------|-------------|
| inches.                    | feet.                                  | £ s. d.     |
| 24 X 19 X 24               | 800                                    | 15 0 0      |
| 30 X 21 X 26               | 1200                                   | 19 0 0      |
| 36 X 23 X 29               | 1600                                   | 22 10 0     |
| 42 X 24 X 32               | 2000                                   | 27 0 0      |
| 48 X 26 X 32               | 2500                                   | 33 0 0      |
| 54 X 27 X 34               | 3000                                   | 40 10 0     |

GEORGE BOWER, ST. NEOTS, HUNTINGDONSHIRE.

PRICE LIST OF HOT-WATER PIPES, CONNECTIONS, AND FITTINGS.

PATENT PIPES.

COMMON SOCKET PIPES.

| No. | Inside Diameter.      | 2 in.   |    | 3 in. |    | 4 in. |    | 5 in. |    | 6 in. |    | No. | Inside Diameter. | 2 in.   |    | 3 in. |    | 4 in. |    | 5 in. |    | 6 in. |    |
|-----|-----------------------|---------|----|-------|----|-------|----|-------|----|-------|----|-----|------------------|---------|----|-------|----|-------|----|-------|----|-------|----|
|     |                       | s.      | d. | s.    | d. | s.    | d. | s.    | d. | s.    | d. |     |                  | s.      | d. | s.    | d. | s.    | d. | s.    | d. | s.    | d. |
| *   | Pipes, 9-ft. lengths  | per yd. | .. | 2     | 4  | 3     | 0  |       |    |       |    | *   |                  | per yd. | .. | 1     | 10 | 2     | 3  | 4     | 0  | 5     | 4  |
| *   | " 6-ft. "             | "       | 1  | 6     | .. | ..    | .. |       |    |       |    | *   |                  | "       | 1  | 1     | .. | ..    | .. | ..    | .. | ..    | .. |
| 1   | Inside Elbow          | each    | 2  | 0     | 2  | 9     | 3  | 6     |    |       |    | 1   |                  | each    | 1  | 8     | 2  | 4     | 2  | 11    |    |       |    |
| 2   | Middle "              | "       | 2  | 8     | 4  | 2     | 5  | 0     |    |       |    | 2   |                  | "       | 2  | 3     | 3  | 7     | 4  | 4     |    |       |    |
| 3   | Outside "             | "       | 4  | 0     | 6  | 0     | 8  | 6     |    |       |    | 3   |                  | "       | 3  | 4     | 4  | 8     | 5  | 10    |    |       |    |
| 4   | Close Syphon          | "       | 2  | 0     | 3  | 11    | 5  | 5     |    |       |    | 4   |                  | "       | 1  | 8     | 3  | 6     | 4  | 10    |    |       |    |
| 5   | 3-way "               | "       | 3  | 6     | 5  | 7     | 7  | 4     |    |       |    | 5   |                  | "       | 3  | 0     | 5  | 0     | 6  | 8     |    |       |    |
| 6   | 4-way "               | "       | 4  | 6     | 7  | 6     | 9  | 0     |    |       |    | 6   |                  | "       | 4  | 6     | 7  | 6     | 9  | 0     |    |       |    |
| 7   | Outlet Syphon         | "       | 3  | 6     | 5  | 0     | 6  | 6     |    |       |    | 7   |                  | "       | 2  | 7     | 4  | 4     | 6  | 6     |    |       |    |
| 8   | 3-way "               | "       | 4  | 0     | 6  | 0     | 8  | 0     |    |       |    | 8   |                  | "       | 3  | 6     | 5  | 4     | 7  | 0     |    |       |    |
| 9   | 4-way "               | "       | 5  | 4     | 8  | 0     | 10 | 8     |    |       |    | 9   |                  | "       | 5  | 4     | 8  | 0     | 10 | 8     |    |       |    |
| 10  | Elbow Syphon          | "       | 3  | 6     | 5  | 0     | 6  | 6     |    |       |    | 10  |                  | "       | 2  | 7     | 4  | 4     | 6  | 6     |    |       |    |
| 11  | 3-way "               | "       | 4  | 1     | 6  | 3     | 9  | 2     |    |       |    | 11  |                  | "       | 3  | 8     | 5  | 7     | 8  | 0     |    |       |    |
| 12  | 4-way "               | "       | 5  | 4     | 8  | 0     | 10 | 8     |    |       |    | 12  |                  | "       | 5  | 4     | 8  | 0     | 10 | 8     |    |       |    |
| 13  | Side Outlet Syphon    | "       | 3  | 6     | 5  | 0     | 6  | 6     |    |       |    | 13  |                  | "       | 3  | 0     | 5  | 0     | 6  | 6     |    |       |    |
| 14  | 3-way "               | "       | 4  | 0     | 6  | 0     | 8  | 0     |    |       |    | 14  |                  | "       | 4  | 0     | 6  | 0     | 8  | 0     |    |       |    |
| 15  | 4-way "               | "       | 5  | 4     | 8  | 0     | 10 | 8     |    |       |    | 15  |                  | "       | 5  | 4     | 8  | 0     | 10 | 8     |    |       |    |
| 16  | 4-way Branch Pipes    | "       | 5  | 4     | 8  | 0     | 10 | 8     |    |       |    | 16  |                  | "       | 5  | 4     | 8  | 0     | 10 | 8     |    |       |    |
| 17  | 6-way "               | "       | 7  | 10    | 12 | 0     | 16 | 0     |    |       |    | 17  |                  | "       | 7  | 10    | 12 | 0     | 16 | 0     |    |       |    |
| 18  | 8-way "               | "       | 10 | 8     | 16 | 0     | 21 | 4     |    |       |    | 18  |                  | "       | 10 | 8     | 16 | 0     | 21 | 4     |    |       |    |
| 19  | H Pipe                | "       | 4  | 3     | 7  | 0     | 8  | 6     |    |       |    | 19  |                  | "       | 3  | 7     | 5  | 9     | 6  | 6     |    |       |    |
| 20  | Y Pipe                | "       | 3  | 6     | 5  | 6     | 7  | 6     |    |       |    | 20  |                  | "       | 2  | 7     | 4  | 4     | 6  | 6     |    |       |    |
| 21  | T Piece               | "       | 3  | 0     | 4  | 6     | 5  | 6     |    |       |    | 21  |                  | "       | 2  | 8     | 4  | 6     | 5  | 6     |    |       |    |
| 22  | S Bend                | "       | 3  | 6     | 5  | 6     | 6  | 6     |    |       |    | 22  |                  | "       | 3  | 6     | 5  | 6     | 6  | 6     |    |       |    |
| 23  | Swan Necks            | "       | 3  | 6     | 5  | 0     | 6  | 6     |    |       |    | 23  |                  | "       | 3  | 6     | 5  | 6     | 6  | 6     |    |       |    |
| 24  | Double Socket         | "       | 1  | 6     | 2  | 10    | 3  | 9     |    |       |    | 24  |                  | "       | 1  | 6     | 2  | 6     | 3  | 6     |    |       |    |
| 25  | Flange "              | "       | 2  | 0     | 3  | 0     | 3  | 4     |    |       |    | 25  |                  | "       | 2  | 0     | 3  | 0     | 3  | 4     |    |       |    |
| 26  | Male Cap              | "       | 1  | 1     | 1  | 6     | 2  | 3     |    |       |    | 26  |                  | "       | 1  | 7     | 10 | 1     | 0  |       |    |       |    |
| 27  | Female "              | "       | 10 | 1     | 1  | 1     | 6  |       |    |       |    | 27  |                  | "       | 1  | 0     | 1  | 4     | 1  | 9     |    |       |    |
| 28  | Glands                | "       | 8  |       | 9  | 11    | 0  |       |    |       |    | 28  |                  | "       | .. | ..    | .. | ..    | .. |       |    |       |    |
| 29  | Box End and Gland     | "       | 8  | 4     | 11 | 6     | 16 | 6     |    |       |    | 29  |                  | "       | .. | ..    | .. | ..    | .. |       |    |       |    |
| 30  | Box End & Gland Piece | "       | 5  | 0     | 6  | 6     | 8  | 6     |    |       |    | 30  |                  | "       | .. | ..    | .. | ..    | .. |       |    |       |    |
| 31  | Reducing Socket       | "       | 2  | 0     | 2  | 6     | 3  | 6     |    |       |    | 31  |                  | "       | 2  | 0     | 2  | 6     | 3  | 6     |    |       |    |
| 32  | Slip Socket           | "       | 1  | 4     | 2  | 3     | 3  | 3     |    |       |    | 32  |                  | "       | 1  | 4     | 2  | 1     | 3  | 0     |    |       |    |
| 33  | Throttle Valve        | "       | 12 | 6     | 15 | 0     | 17 | 0     |    |       |    | 33  |                  | "       | 12 | 6     | 15 | 0     | 17 | 0     |    |       |    |
| 34  | " "                   | "       | 12 | 6     | 15 | 0     | 17 | 0     |    |       |    | 34  |                  | "       | 12 | 6     | 15 | 0     | 17 | 0     |    |       |    |
| 35  | Stop Valve            | "       | 17 | 0     | 21 | 6     | 26 | 0     |    |       |    | 35  |                  | "       | 17 | 0     | 21 | 6     | 26 | 0     |    |       |    |
| 36  | " "                   | "       | 17 | 0     | 21 | 6     | 26 | 0     |    |       |    | 36  |                  | "       | 17 | 0     | 21 | 6     | 26 | 0     |    |       |    |
| 37  | A Standard            | "       | .. | ..    | .. | ..    | .. |       |    |       |    |     |                  |         |    |       |    |       |    |       |    |       |    |
| 38  | Bar and Rollers       | "       | .. | ..    | .. | ..    | .. |       |    |       |    |     |                  |         |    |       |    |       |    |       |    |       |    |

ORNAMENTAL FLOOR PIPE, 16s. per Pipe. CORNERPLATES, each 1s. 6d. JOINT PLATES, each 1s. 6d.

COILS PLAIN AND ORNAMENTAL, prices according to Sizes and Description. COIL CASES AND GRATINGS, in a variety of Designs.

ESTIMATES GIVEN FOR HEATING ALL KINDS OF BUILDINGS, WITH HOT WATER, STEAM, OR HOT AIR.

[SECTION X]

AIR LIGHT APPARATUS.

(Page 169 of Catalogue.)

|                           |          |         |         |         |         |          |
|---------------------------|----------|---------|---------|---------|---------|----------|
| No. of Lights will supply | 5        | 15      | 25      | 50      | 75      | 100      |
| Prices at St. Neots       | £12 10 0 | £20 0 0 | £35 0 0 | £50 0 0 | £75 0 0 | £100 0 0 |

Packing for export, and delivery at a Shipping Port in England, 5 per Cent. extra on cost.

LARGER SIZES ON APPLICATION.

IPSWICH:  
REES AND CO., PRINTERS, BUTTER MARKET.

