

INDUSTRIAL USES  
OF  
FUEL OIL

tv

By  
F. B. DUNN



LIBRARY OF THE  
UNIVERSITY OF CALIFORNIA  
SAN FRANCISCO

TECHNICAL PUBLISHING COMPANY  
618 MISSION STREET, SAN FRANCISCO

1916  
Co.

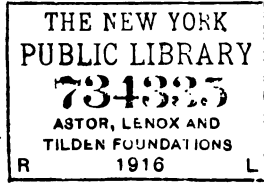

Copyright 1916  
BY  
TECHNICAL PUBLISHING  
COMPANY

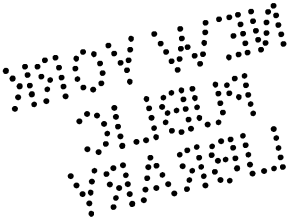

## PREFACE.

This book is intended to be a practical exposition of the use of fuel oil for industrial purposes. Oil is an ideal fuel for most manufacturing operations. Brief description of many of these processes precedes, in each case, the detailed directions for furnace and burner arrangement as well as approved methods of operation.

From a study of this work, the engineer, architect, plant superintendent, manager, fuel oil salesman and efficiency expert should be able to judge as to the applicability of fuel oil to their purpose. The chapters on Tests and Furnace Efficiency should prove of special value to operating engineers, as it teaches how boiler losses may be checked and true efficiency determined.

The text has been written by a practical man for the use of practical men. Its preparation has occupied much of the author's spare time for a number of years past. Should it prove of service to the engineer and make known the advantages of fuel oil, the effort will be amply repaid.

THE AUTHOR.

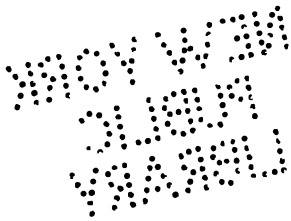

## TABLE OF CONTENTS

### CHAPTER I.

Oil as a Fuel—Supply of oil—Comparison value of oil—Economic value of oil—Purchasing of oil—Measurement of oil—Actual heat losses of coal—Analysis of various grades of oil and properties that are refined from them—Properties of different oils—Distillation of crude oil—Production of oil in all parts of the world.

### CHAPTER II.

Oil Storage and Pumping Systems—Rules governing the installation of fuel oil storage tanks—Capacities of oil tanks—Construction of storage tanks—Unloading oil from tank cars—Various types of oil pumping systems.

### CHAPTER III.

Boiler Furnace Arrangement—Method of arranging tubular, water tube, Scotch marine and upright boiler furnaces for oil—Height of chimney required when using oil.

### CHAPTER IV.

Oil Burners—Inside mixing burners—Outside mixing burners—Gravity burners—Steam atomizing burners—Air atomizing burners—Mechanical burners—Rotary burners—Temperature of oil required to operate burners—Pressure required on oil to burners.

### CHAPTER V.

Oil Strainers and Heaters—Basket type of oil strainer—Duplex type strainer—Self-cleaning oil strainer—Plain heater—Condensing type heater—Corrugated type heater—Multi-unit heater—Necessity of straining and heating the oil—Automatic regulator governing the pressure of steam—Automatic draft regulator governing the steam pressure and dampers.

### CHAPTER VI.

Oil in the Clay, Lime and Cement Industries—Types of brick kilns—The up-draft kiln—The down-draft kiln, and the muffle kiln—Position of oil burners—Kind of fire required—Oil required per 1000 bricks—Reports on various brick kilns—Muffle kiln for enamel-ware—Composition of fire brick—Analysis of common brick clays—Lime kilns—Process of making lime—Reports on lime kilns using oil—Burners applied to kilns—Cement—Composition and action of heat on ingredients used in manufacturing—The rotary kiln—Comparison reports on plants using oil as fuel.

## TABLE OF CONTENTS

### CHAPTER VII.

Oil in the Glass Industry—Various grades of glass—Process of manufacture—Annealing ovens—Glass blowing—Glass furnaces—Annealing furnace—Oil required—Advantages of oil over other fuels.

### CHAPTER VIII.

Oil Burning Locomotives—Early reports on Griagi-Tsaritzin Railway in Russia—Recent reports on Pacific Coast on latest type locomotive—Arrangement of fire-box and ash pan on the first locomotives changed by the Santa Fe Railway Company—Modern method of arranging fire-box—Method of changing coal tender to oil—Details of latest type oil tender—Cost of changing locomotives from coal to oil—Comparison report of locomotives of the passenger consolidation and Mallet consolidation types.

### CHAPTER IX.

Oil in the Sugar and Rubber Industries—Analysis of ripe sugar cane—Use of fibre or bagasse as a fuel—Comparison values of bagasse from different fields—Percentage of extra fuel required when using bagasse—Types of furnaces used when burning oil and bagasse—Refuse obtained from Guayule plant while extracting rubber—Value of refuse or bagasse as a fuel—Comparison report of coal, bagasse and oil as fuel at a large rubber plant.

### CHAPTER X.

Smelting Furnaces Fired with Oil—Difficulties with other fuels—Use of oil in reverberatory and roasting furnaces—Report on reverberatory furnace—Comparison report on coal and oil in a reverberatory furnace—Experimental furnaces for smelting ores—Blast furnace operated with fuel oil—Report showing the grade of cast iron, with old coke cupola and the superior grade with oil furnace.

### CHAPTER XI.

Metallurgical and Shop Furnaces—Reports on muffle furnace from mining companies—Crucible furnaces—Blacksmith forge—Small heating furnace—Rivet heating furnace—Heat treating furnace—Semi-muffle furnace—Portable furnace or burner—Reports on oil used in various industries—Report on filling furnaces with oil—Fuel required to heat 100 pounds of metal—Comparative results with coke furnace and with oil furnace—Comparison report from actual practice on brass furnaces.

### CHAPTER XII.

Oil in the Steel Industry—Open hearth process—Arrangement of oil installation in open hearth furnaces—Types of burners—Ladle drying burner—Reports from several steel plants using oil as fuel—The value of a pyrometer in steel making—Heat balance on an open hearth furnace showing economy effected by preheating air for combustion—Value of waste heat from furnaces—Crucible steel furnace—Report on billet heating furnace.

## TABLE OF CONTENTS

### CHAPTER XIII.

Fuel Oil for Naval and Maritime Purposes—Early tests and development—Extra water required for furnishing steam to atomize oil—Advantages of mechanical system over air or steam atomizing burners—Spray system—Coen system—White system—Koerting system—Dahl system—Furnace arrangements using the mechanical systems—Report on "Idalia" tests—Report on S. S. "Tenyo Maru," using a combination of coal and oil—U. S. regulations for the installation of fuel oil on ocean and coastwise steam vessels—Lloyd's rules for the burning and caring of oil fuel—Report or extract of log on S. S. "Matsonia"—Tests conducted by U. S. on U. S. R. C. "Golden Gate."

### CHAPTER XIV.

Fuel Oil for Domestic Purposes—Oil in the home—Stove burners—Large ranges—Installation made for U. S. Government at Fort Baker, Cal.—Gravity systems—Automatic control systems—Combination systems—Bake oven systems—Vulcan ejector system.

### CHAPTER XV.

The Rotary System of Burning Oil—Early experiments—Trials by U. S. Naval Liquid Fuel Board—The Fess rotary system—Boiler tests with rotary system—Ray's crude oil burner—The M. & W. rotary oil burner—Comparative cost of heating with gas, wood, electricity or steam service—Data for estimating cost of heating—Cost of heating buildings, homes, apartment houses, etc.—Table of oil required for heating.

### CHAPTER XVI.

Furnace Efficiency and Combustion—Result of complete combustion—Table of CO<sub>2</sub> and fuel losses—How to take flue gas readings—The Orsat apparatus—Air required for combustion—Heat units per pound of oil—Report of test.

### CHAPTER XVII.

Tests and Reports—Necessity of conducting tests—Data required to conduct test—Report of test—Explanations of methods used in figuring test—Formulas used in figuring results—Report on competitive steam and air tests, showing quantities used.

### CHAPTER XVIII.

Oil for Gas Making—The first use of oil for gas making—Carburetted water gas—Water gas—Crude water gas—Improved method of gas making—Report from modern gas plant—Analysis of various gases—Lampblack as a by-product.

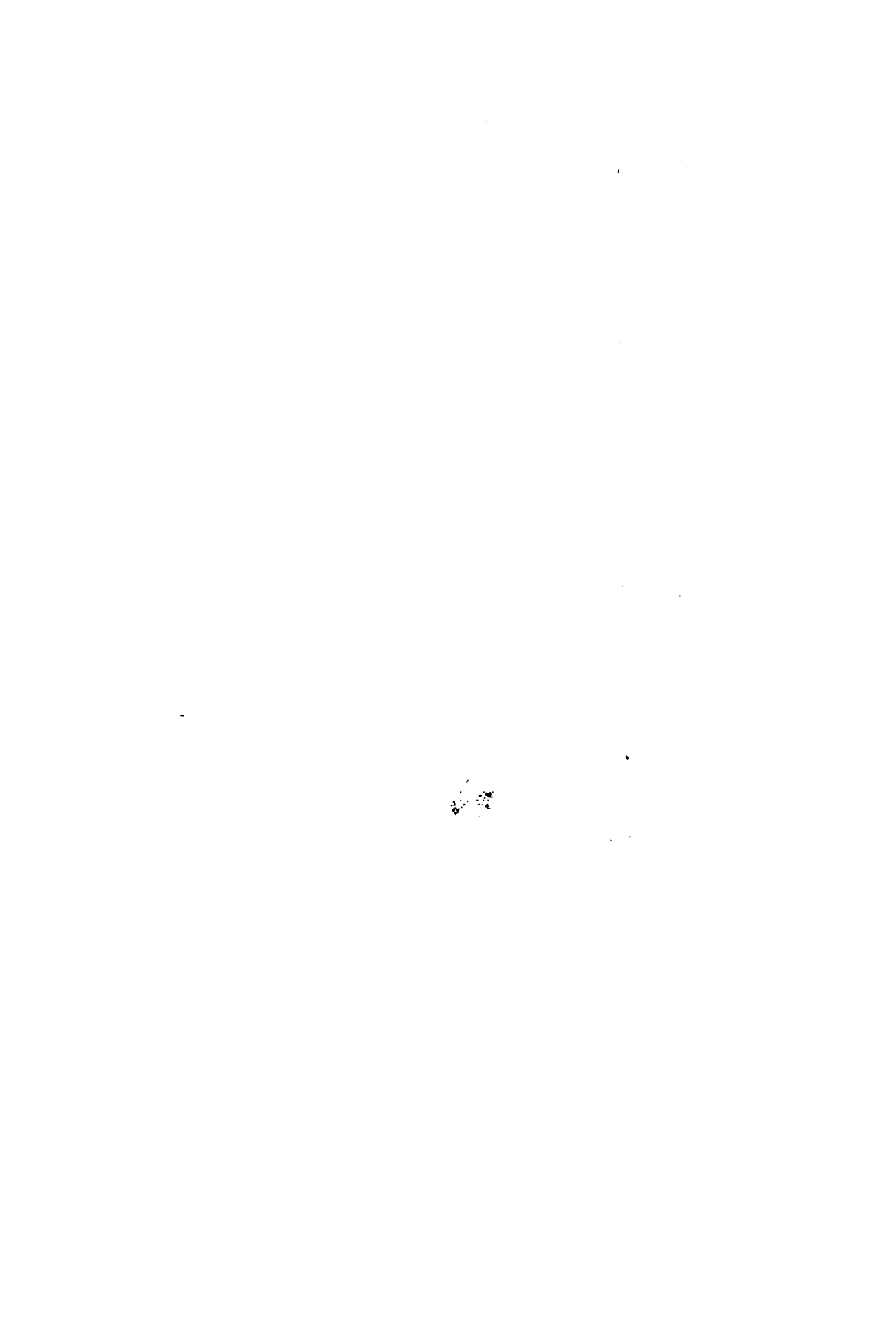



# INDUSTRIAL USES OF FUEL OIL

---

## CHAPTER I.

### OIL AS A FUEL.

The use of oil as fuel has been a remarkable development of the past few years. After carefully investigating the source of supply, both the older oil fields that have long been producing as well as the newer fields, such as those in Mexico, together with the possibilities of finding oil in Central and South America, the navies of the world have decided to adopt oil as fuel for part of their fleet, at least. With the erection of large oil storage tanks throughout the important seaports of the world the steamship companies also do not now hesitate to equip their steamers for burning fuel oil.

The opening of the Panama Canal has changed the old established routes of many steamship lines and fuel oil from the California, Mexican and Central American fields can be obtained at an attractive figure at the Canal. Thus steamers operating from New York or European ports, through the Canal to Pacific or China ports, are now able to take advantage of the cheap fuel. The large oil storage tanks that have been erected through the country, insure to the industrial manufacturer also, a steady and regular supply of fuel oil.



These vast storage tanks, the many oil tank cars operated by the railroads, the numerous tank steamers carrying the oil to all parts of the world, and the new oil fields have eliminated any question as to an adequate supply.

The use of fuel oil is now well established, and new uses are being discovered daily. The question of cheap transportation of this valuable product has been solved by the large tank steamers, some of which carry over 120,000 bbl. of oil. When the authorities decide the rate question of transporting oil by tank cars and pipe lines, a still lower price will probably prevail.

Some crude oils are suitable for fuel in their natural state, for others lighter gases must be distilled. Most of the fuel oil sold has been refined, being the residue from the crude petroleum after the more valuable ingredients have been taken out and much of the sulphur removed. The calorific value of the fuel oils from the different countries varies but little from 18,500 B.t.u.

In figuring the comparative value of fuel oil and coal the steam engineer usually compares the amount of water evaporated by unit weights of oil and coal; the electrical engineer figures the kilowatt hours produced with each pound of fuel, while manufacturers are interested in the equivalent value of a barrel of oil, compared with a ton of coal, a cord of wood, or a thousand cubic feet of gas. On account of the widely different heating values of various fuels, it is difficult to prepare a table showing exactly the equivalent value of one barrel of oil. The following table affords a rough comparison between coal fuel under similar conditions of boiler loading.

TABLE I.

Fuel—	Coal.	Oil.
Gravity of Oil, Baume .....		16.2°
Per cent of moisture in fuel.....	3.9	1.5
Per cent of ash .....	17.87	
Calorific value, by Parr Calorimeter, per pound of dry fuel, B.t.u.....	11,811.	18,099.
<b>Boiler Horsepower—</b>		
Horsepower developed, A. S. M. E. rating	832.3	241.
Builder's rated horsepower .....	700.	200.
Per cent of builder's rating developed..	118.9	120.
<b>Economic Results—</b>		
Water apparently evaporated under actual conditions per pound of fuel..	7.118	13.12
Equivalent evaporation, F. & A., 212° F. per pound of fuel .....	9.0767	15.11
Same per pound of dry fuel.....	9.4451	15.34
Same per pound of combustible.....	11.83	15.34
<b>Efficiency—</b>		
Efficiency of boiler .....	82.76	81.8
Per cent of steam generated used by stoker .....	5.8	
By burner .....		3.58
<b>Analysis of Dry Gases by Volume—</b>		
Carbon dioxide .....	7.82	14.6
Oxygen .....	7.50	1.2
Carbon monoxide .....	.13	.00
Nitrogen .....	84.55	84.2
Per cent of excess air above amount theoretically required .....	50.	5.6

It has been common practice to estimate four barrels of oil equal to one ton of coal, but that this is not always the case is proved by the following test. Under a boiler one pound of coal evaporated 7 lb. of water from and at 212 degrees F., and one pound of oil evaporated 15 lb. of water from and at 212 degrees F. The rates of evaporation per pound of fuel were in the ratio of 7 to 15; and as the coal weighed 2000 lb. per ton and the oil 330 lb. per barrel, one ton of coal was

equivalent to  $\frac{2000 \times 7}{330 \times 15} = 2.828$  barrels of oil. On

the other hand, a good grade of coal may have 14,500 B.t.u. per pound, while oil averages 18,500 B.t.u. per pound. The theoretical equivalent of one ton of coal

in this case is  $\frac{2000 \times 14500}{330 \times 18500} = 4.75$  barrels of oil.

These cases may seem extreme, but they indicate the danger of using "rules of thumb" in making prelimi-

nary calculations of fuel consumption. The writer has seen many cases in which a contractor has failed to meet his specifications, simply because he took it for granted that four barrels of oil were the equivalent of one ton of coal.

It is equally difficult to compare the heating value of a cord of wood with that of a barrel of oil. The heating value of the wood in question must be known, as well as the percentage of water that it contains, before making a comparison with oil fuel.

The type of furnace in which the oil is to be used is an important consideration in making any comparison with other fuels. Assume, for example, a furnace which has an efficiency of 76 per cent when burning coal. If, upon converting this furnace to an oil-burner, it has an efficiency of 83 per cent, the amount of oil required will be less than the amount indicated by a comparison of the heating values of coal and oil. As a rule such an improvement in efficiency may be expected from the conversion of a coal burning to an oil burning furnace, provided the installation is made by a competent oil expert. This is partially due to the higher furnace efficiency inherently attainable with fuel oil. But a more important cause lies in the fact that the average plant using coal as fuel is attended by an unskilled fireman, who can only get the best results from coal by hard work, close attention, and intimate knowledge of the coal. Often he does not understand the most efficient method of firing the coal or regulating the draft, and as a result a great deal of fuel is wasted. This point is clearly brought out when a coal or boiler expert is brought in to conduct a test; much higher efficiencies are invariably attained.

Conditions are very different in a plant using oil. The work of firing requires no physical exertion; a clear eye and common sense is all that is required. The fireman has plenty of time to see that the burner is working properly and that a uniform amount of feed water is being supplied; and by watching the stack he can prevent some of the fuel losses that take place if smoking is permitted. Also, when using fuel

oil a much better class of labor can be secured; this has been clearly proven on board ocean going steamers.

The writer can remember the time when it was almost impossible to secure firemen on a certain steamer, and many that were secured were unfit for work during their first watch, three watches being often required to get them in good working condition. It was laborious, hot work, as the steamer was running to the tropics. The firemen usually made but one voyage and a new crew had to be obtained each trip. This vessel is now using fuel oil, and I have been informed by the engineers, that they seldom make a change in the fire room crew.

#### Purchasing Fuel Oil.

With the supply of oil fuel assured, the question of greatest interest to the engineer is how to buy it. The price of the oil must of course be low enough to warrant making the fuel oil installation. And the time for which this price is guaranteed in the fuel oil contract should be long enough to enable the consumer to save on his fuel bill at least the cost of making the oil installation.

The analysis of crude and fuel oils varies with the wells or countries from which the oil is obtained. The characteristics required by the purchaser should be embodied in a contract; a good commercial fuel oil should be of the following specifications:

Specific Gravity at 60° Beaume .....	Not less than 14°
British thermal units .....	Not less than 18,500
Water .....	Not over ½%
Sulphur .....	Not over 2%
Dirt, sand, etc. ....	None
Flash point .....	Not lower than 140° F.

**Measurement of Oils at a Temperature Above 60° F.**

Let  $Q$  = actual quantity.

Let  $Q'$  = measured quantity.

$c$  = a constant for the particular oil.

$t$  = temperature of oil in degs. F.

$$\text{Then } Q = Q' \div 1 + \frac{c(t-60)}{10}$$

**Measurement of Oils at a Temperature Below 60° F.**

$$Q = Q' \div 1 - \frac{c(60-t)}{10}$$

The value of "c" in this equation is based on the coefficient of expansion of the oil and differs for different oils. Generally speaking, the lighter the oil the higher the coefficient and also the value of "c."

From determinations made in our laboratories we have arrived at a close approximation to the correct coefficients of expansion for California oils, as follows:

For California oil of 10 deg. B. "c." = .0033

For California oil of 11 deg. B. "c." = .0033

For California oil of 12 deg. B. "c." = .0034

For California oil of 13 deg. B. "c." = .0034

For California oil of 14 deg. B. "c." = .0035

For California oil of 15 deg. B. "c." = .0036

For California oil of 20 deg. B. "c." = .0039

For California oil of 25 deg. B. "c." = .0042

Many purchasers of road oils use an arbitrary constant for all oils, but that this is manifestly incorrect is clearly shown by the above table. The constant used by the Los Angeles County, Cal., Highway Commission and recommended by Prevost Hubbard, Chemist in the Office of Public Roads of the United State Agricultural Department is — "c" = .004

This would be correct for California oils of about 21 deg. B. or 22 deg. B.; but as most road oils are heavier than this the result of the use of this constant is an error in the measurement of all oils delivered at a temperature above or below 60 deg. F.

**Comparative Value of Wood, Oil and Coal.**  
(Average coal)

Class of Wood.	Weight in lb. of one cu. ft. of wood.	Weight of coal that one cord of wood is equivalent to in evaporation power.	B.t.u.	Equivalent lb. of oil per cord of wood.	Weight per cord of wood kiln dried.
English oak....	48-58	1560	8,316	1730	3850
Ash .....	43-53	1420	8,480	1610	3530
Red oak.....	54	1340	8,390	1501	3310
Birch .....	40-46	1190	8,510	1384	2880
Elm .....	34-45	1190	8,586	1337	2880
Yellow pine....	29-41	1130	9,153	1248.	2520
White pine.....	27-34	970	9,215	956	1920
Beech .....	43-53	1420	8,591	1635	3520

**Heat Losses Attending the Use of Coal in a Small Factory.**

(As shown by the U. S. Geological Survey at the Panama-Pacific International Exposition.)

	Per Cent.
<b>Boiler Room Losses.</b>	
Losses by combustible matter falling through grate.....	3
Loss in chimney gases.....	26
Loss due to moisture in coal.....	4
Loss due to incomplete combustion.....	5
Loss due to radiation .....	5 43
<b>Engine Room and Factory Losses.</b>	
Loss in condenser.....	43
Loss in auxiliaries.....	4
Loss in friction of engine shafting, etc.....	4
Loss by friction of manufacturing machines.....	3 54
Heat utilized in useful work.....	3
<b>Total .....</b>	<b>100</b>

**In the Best Steam Power Plant Having a Direct Connected Engine.**

	Per Cent.
<b>Boiler Room Losses.</b>	
Losses by combustible matter falling through grate....	2
Loss in chimney gases.....	10.5
Loss due to moisture in coal.....	4.5
Loss due to incomplete combustion.....	0.5
Loss due to radiation.....	2.5 20
<b>Engine and Factory Losses.</b>	
Loss in condenser.....	60.
Loss in auxiliaries.....	.25
Loss by friction in a direct connected engine.....	1.75 62
Heat utilized in output of machines.....	18
<b>Total .....</b>	<b>100</b>

The losses as shown in the best steam power plant are about the average losses in per cent as average plant using oil as fuel, but the losses in a small factory using oil as fuel do not average 45 per cent in the boiler room. The large percentage of the losses being in the chimney gases with coal, while with oil this percentage is greatly reduced.—Author.





Comparison Values of Various Oils.

	Mexican Crude Oil.	German Coal Tar Oil.	Gas Oil.	Pacura (Roumania)	Mazut (Russian)	California Residue Brand K.	California Residue Brand L.
Carbon	83.21%	90.12%	86.98%	.....	85.67%	84.00%	84.78%
Hydrogen	11.32	7.09	12.15	.....	12.13	11.07	11.85
Sulphur	2.43	0.63	.71	.....	.05	.87	.84
Oxygen and Nitrogen	2.90	1.66	.16	.....	.72	3.93	2.45
Inc combustible	14	.50	.....	.....	1.43	.13	.08
Specific gravity	.937 at 15°C.	1.065 at 15°C.	.85 at 15°C.	.90 to .98	.9 at 15°C.	.864	.935
Viscosity	4.11 at 64°C.	1.66 at 20°C.	1.14 at 20°C.	.....	19.96 at 20°C.	6.41 at 80°C.	2.22 at 80°C.
Asphaltum	45.6%	.....	.....	.....	17.800	48.1%	12.9%
C calorific value in B.t.u.'s per lb.	17,460	15,950	18,000	140°C.	113°C.	17,400	17,550
Flash point	.....	98°C.	80°C.	.....	.....	Ignites in open dish at 137°C.	85°C.

Table 1. Properties of Different Oils.

Baume Gravity.	Specific Gravity.	Weight lb. per gal.	Weight lb. per bbl.	B.t.u. per lb.	B.t.u. per bbl.	Weight cu. ft.	Cu. Ft. ton.	Gals. ton.	Bbls. ton.
10	1.0000	8.33	349.86	18,280	6,395,441	62.355	35.9	268.9	6.43
11	0.9929	8.27	347.34	18,340	6,370,216	61.912	36.1	270.8	6.46
12	0.9859	8.21	344.82	18,400	6,344,688	61.475	36.5	272.8	6.50
13	0.9790	8.16	342.72	18,460	6,326,611	61.045	36.7	274.6	6.54
14	0.9722	8.10	340.20	18,520	6,309,504	60.621	36.9	276.6	6.59
15	0.9655	8.04	337.68	18,580	6,274,094	60.202	37.2	278.6	6.65
16	0.9589	7.99	335.58	18,640	6,255,111	59.792	37.5	280.3	6.69
17	0.9523	7.93	333.06	18,700	6,237,622	59.380	37.7	282.4	6.73
18	0.9459	7.88	330.96	18,760	6,208,810	58.981	38.1	284.2	6.77
19	0.9395	7.83	328.86	18,820	6,189,145	58,582	38.3	286.9	6.82
20	0.9333	7.78	326.76	18,880	6,169,229	58,195	38.5	288.9	6.86
21	0.9271	7.72	324.24	18,940	6,141,106	57,809	38.8	290	6.91
22	0.9210	7.67	322.14	19,000	6,120,660	57,428	39	292	6.96
23	0.9150	7.62	320.04	19,060	6,199,962	57,053	39.2	293.9	7.01
24	0.9090	7.57	317.94	19,120	6,079,013	56,680	39.5	295.7	7.06
25	0.9032	7.55	316.26	19,180	6,065,867	56,319	39.8	297.4	7.09

**Report on Fuel Oil from Distillation of Crude Oil.**

To get out a fuel oil with a viscosity of 800 secs. (Redwood) at 100 deg. Fahr., we can distill off:

Benzine and kerosene .....	30 per cent.
Gas oil .....	30 per cent.

from which will be steamed off 1 per cent back to benzine.

The residue of 29 per cent is mixed with 26.10 per cent of pitch, giving:

Benzine and kerosene.....	31	per cent
Fuel oil .....	55.10	per cent.
Pitch .....	11.90	per cent.
	<hr/>	
	98.00	per cent.
Loss .....	2.00	per cent.
	<hr/>	
	100.00	per cent.

The fuel oil has the following properties:

Specific gravity at 60 deg. Fahr.	.955
Flash point (Abel).....	170 deg. Fahr.
Viscosity at 100 deg. Fahr.....	810 secs. (Redwood)

If we manufacture only benzines and fuel oil without any illuminating oil at all, we distill off:

Benzines, Sp. Gr. .738.....	10 per cent.
Gas oil, Sp. Gr. 837.....	45 per cent.

from this is to be steamed off 4.5 per cent and the residue of gas oil 40.5 per cent mixed with the whole residue.

This gives:

Benzines, Sp. Gr. .740.....	14.50 per cent.
Loss .....	1.50 per cent.
Fuel oil .....	84.00 per cent.
	<hr/>
	100.00 per cent.

This fuel oil has the following properties:

Specific gravity at 60 deg. Fahr.	.950
Flash point (Abel).....	164 deg. Fahr.
Viscosity at 100 deg. Fahr.....	805 secs.(Redwood)

According to statistics compiled under the supervision of J. D. Northrop of the United States Geological Survey, the quantity of petroleum entering the markets of the world in 1914 amounted to 400,483,489 barrels. Of this record-breaking output the United States is credited with 66.36 per cent, representing in quantity a trifle less than double the output of all the other oil-producing countries combined. The following table shows the marketed production of petroleum in the world in 1914, and for purposes of comparison the corresponding output in 1913, together with the total output from 1857 to 1914 inclusive:

## INDUSTRIAL USES OF FUEL OIL

## By Countries, in Barrels of 42 Gallons.

Country.	1914		1913		Total, 1867-1914	
	Production.	Per Cent.	Production.	Per Cent.	Production.	Per Cent.
United States.....	265,762,535	66.36	248,446,230	64.59	3,335,457,140	59.63
Russia .....	67,020,522	16.74	62,834,356	16.35	1,622,233,845	29.00
Mexico .....	21,188,427	5.29	25,902,439	6.73	90,359,869	1.62
Roumania .....	12,826,579	3.20	13,554,768	3.52	117,932,474	2.11
Dutch East Indies.....	12,705,208	3.17	11,966,357	3.11	138,278,392	2.47
India .....	8,000,000	2.00	7,930,149	2.06	73,979,919	1.32
Gallcia .....	5,033,350	1.26	7,818,130	2.03	131,873,601	2.36
Japan .....	2,738,378	.68	1,942,009	.51	27,051,158	.48
Peru .....	1,917,802	.48	2,133,261	.55	14,306,972	.26
Germany .....	995,764	.25	995,764	.26	12,965,569	.23
Egypt .....	777,038	.19	94,635	.03	1,086,728	.02
Trinidad .....	643,533	.16	503,816	.13	2,069,430	.04
Canada .....	214,805	.05	228,080	.06	23,493,610	.42
Italy .....	39,548	.01	47,356	.01	802,229	.01
Other countries.....	620,000	.16	270,000	.07	1,322,000	.03
Total .....	400,483,489	100.00	384,667,550	100.00	5,593,262,936	100.00

## CHAPTER II.

### OIL STORAGE AND PUMPING SYSTEMS.

Before making the fuel oil installation, a fuel oil expert should be engaged. He should be familiar with the rules and regulations regarding the location of oil storage tanks enforced in the particular locality by the inspectors, fire marshal and insurance officials. These regulations vary greatly in different states and countries. The accompanying illustrations taken from the official San Francisco Fire Department ordinances, will serve to give the reader an idea of the regulations for the installation of fuel oil storage.

Fig. 1 shows boiler in basement, the sidewalk being excavated and used as part of basement and the owner desiring to utilize all the space under the sidewalk for basement purposes. The top of the storage tank should be 4 ft. below the basement floor; a brick or concrete wall not less than 12 inches in thickness should be constructed around the storage tank, extending from the bottom of the tank up to the basement floor. The space between the top of the tank and the basement floor should be filled with earth and the earth covered with the concrete flooring of basement. Flooring at the bottom of the tank is optional.

Fig. 2 shows boiler in basement, the sidewalk being excavated and used as part of basement and the owner finding he cannot go over 4 ft. below the basement floor. The top of the storage tank should be at least 6 in. below the basement floor, a brick or concrete wall not less than 12 inches in thickness should be constructed around the storage tank, extending from the bottom of the tank up to 4 ft. above

**Table of Capacity in Gallons of Cylindrical Tanks per Foot in Length Laying Horizontally**

Diam. Tank	Depth of Liquid										
	6"	1'-0"	1'-6"	2'-0"	2'-6"	3'-0"	3'-6"	4'-0"	4'-6"	5'-0"	5'-6"
6"	1.46										
1'-0"	2.94	5.88									
1'-6"	3.85	9.36	13.22								
2'-0"	4.60	11.75	18.85	23.50							
2'-6"	5.22	13.71	23.02	31.99	36.73						
3'-0"	5.81	15.41	26.40	37.97	47.05	52.88					
3'-6"	6.30	16.95	29.97	42.46	55.01	65.66	71.96				
4'-0"	6.78	18.37	32.16	46.97	61.86	75.62	87.22	94.02			
4'-6"	7.21	19.67	34.63	51.01	67.92	84.30	99.26	111.8	118.9		
5'-0"	7.63	20.90	37.05	54.85	73.38	92.08	109.9	125.9	139.1	146.9	
5'-6"	8.00	22.07	39.23	58.34	78.54	99.12	119.4	138.5	155.6	171.7	
6'-0"	8.38	23.19	41.36	61.64	83.36	105.8	128.1	149.8	170.1	188.3	203.1
6'-6"	8.75	24.16	43.31	64.83	87.96	111.9	136.3	160.2	183.3	204.9	223.6
7'-0"	9.13	25.21	45.62	67.84	92.25	117.8	143.6	169.8	195.9	219.9	242.6
7'-6"	9.42	26.11	47.05	70.69	96.49	123.4	151.2	179.1	207.2	234.1	259.5
8'-0"	9.80	27.08	48.77	73.43	100.2	128.8	158.1	187.7	217.6	244.2	270.5
8'-6"	10.0	27.94	50.42	76.30	104.1	133.9	164.7	195.9	228.1	257.6	290.0
9'-0"	10.4	28.84	52.06	78.61	107.8	138.4	171.1	208.3	237.9	271.5	304.7
9'-6"	10.7	29.70	53.67	81.22	110.9	143.5	177.3	211.9	247.4	282.9	318.2
10'-0"	10.9	30.57	54.66	83.62	114.8	148.3	183.2	219.5	256.4	293.7	331.1

*Example; Diam. of Tank 6'-0". Length of Tank 8'-0".  
 Depth of Water 2'-0".  
 From table, opposite 6'-0" and under 2'-0"  
 the capacity for one foot in length is 61.86 gallons.  
 For 8'-0" in length, the capacity = 61.86 x 8 =  
 493.28 gallons  
 for 2'-0" in depth*

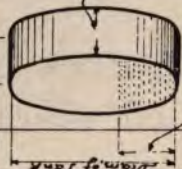

the storage tank. The space between the top of the walls should be filled with earth, the earth covered with at least 3 in. of concrete. The flooring at bottom of tank is optional. All oil pipes exposed in building should be fire-proofed, or under the concrete flooring from the tank to the pump.

5037 532.2 5569 576.5 587.5

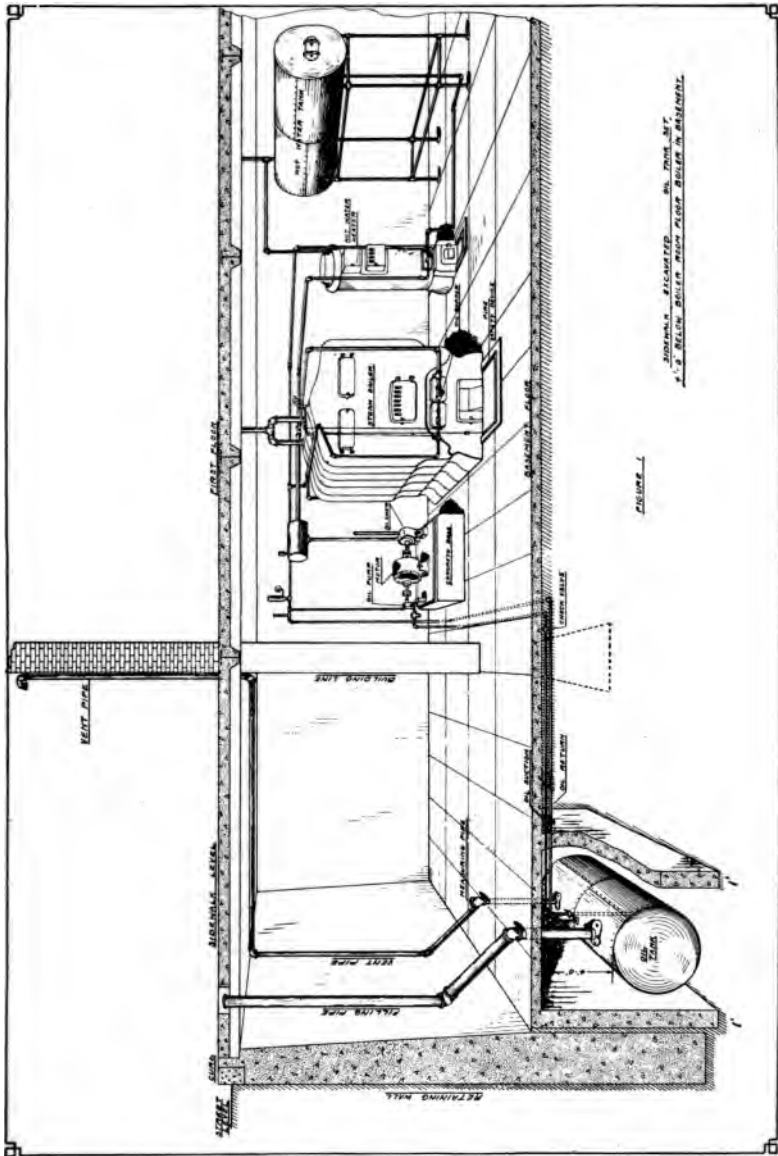

Fig. 1. Showing Approved Method of Oil Installation in Apartment Houses, Hotels, etc.

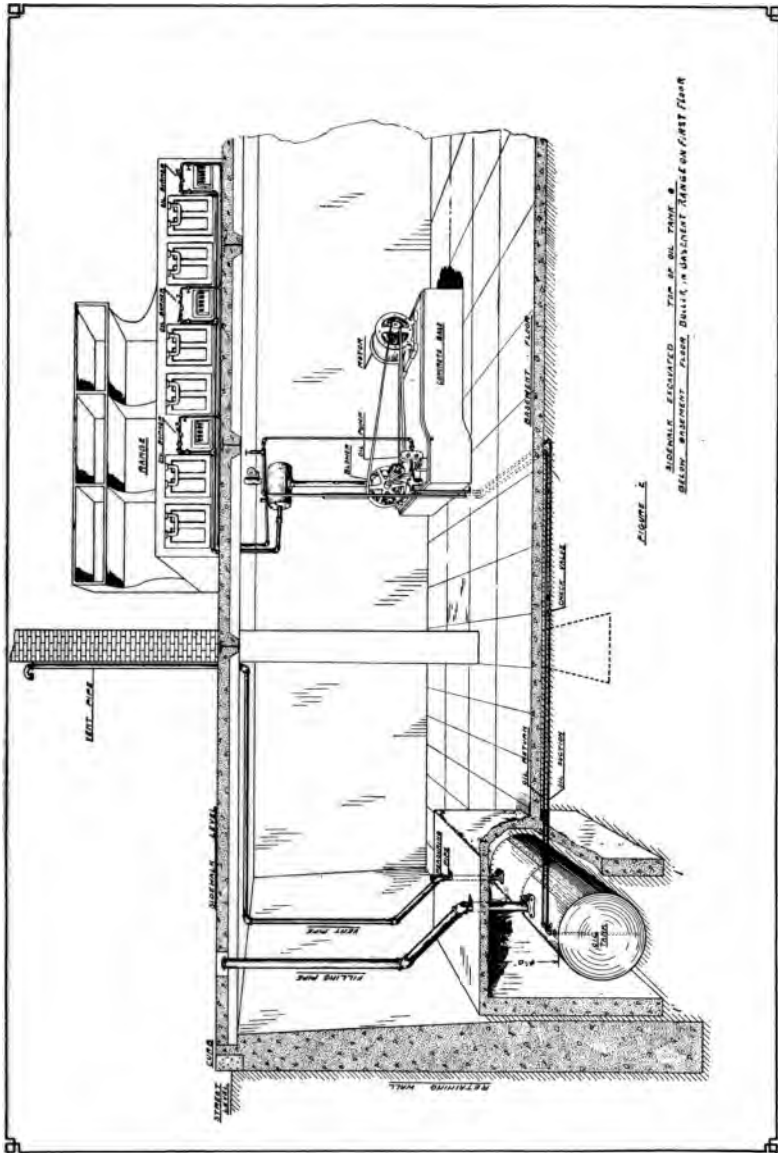

Fig. 2. Showit.



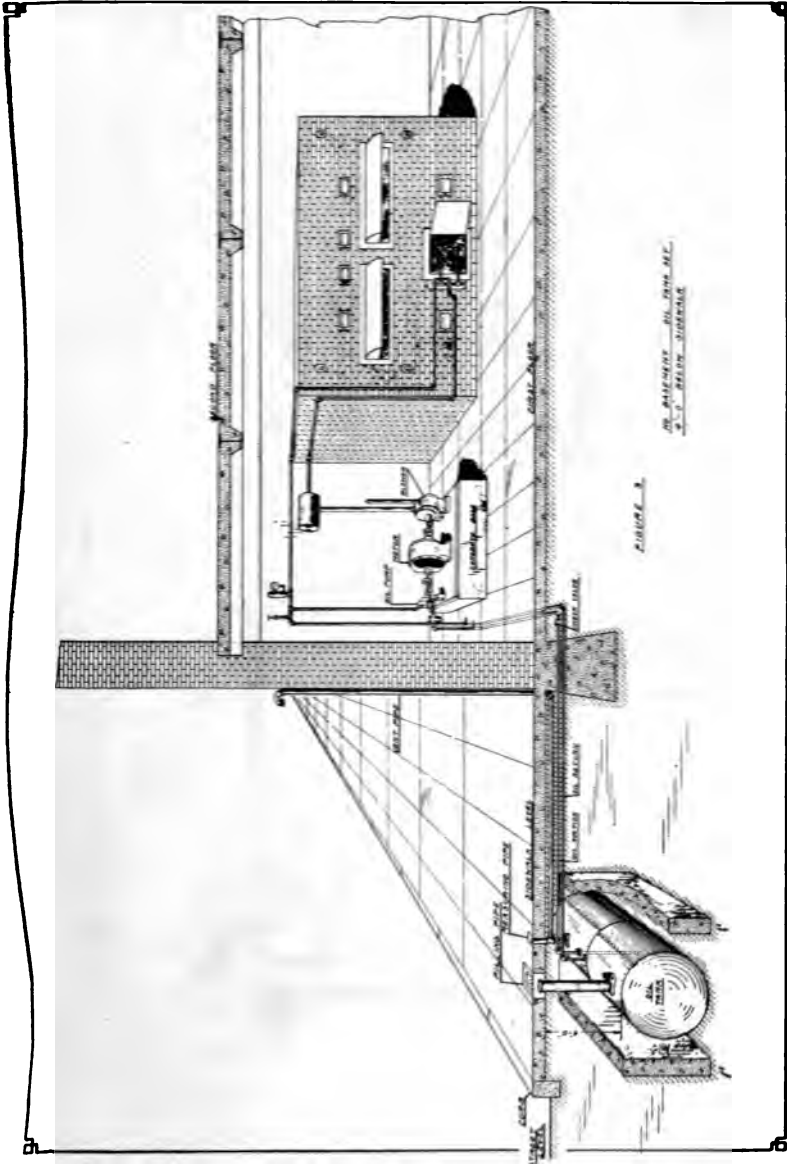

Fig. 3. Showing Approved Method of Oil Installation in a Bakery.

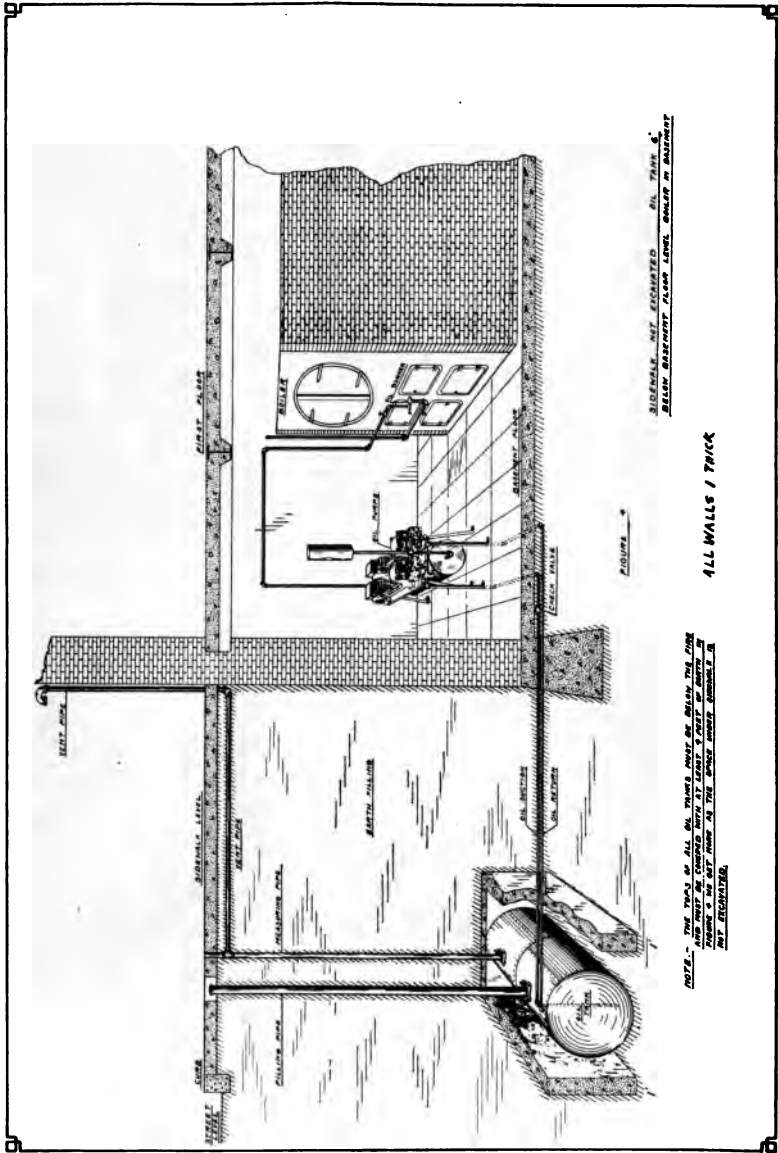

Fig. 4. Showing Approved Method of Installation for a High Pressure Plant

Fig. 3 shows boiler on the first floor, no basement, sidewalk not excavated. The top of the storage tank should be at least 4 ft. below the sidewalk; a brick or concrete wall not less than 12 in. in thickness should be constructed around the storage tank, extending from bottom of tank up to top of tank. The space between the top of the tank and the sidewalk should be filled earth covered with the sidewalk. Flooring at bottom of tank optional.

Fig. 4 shows boiler in basement, sidewalk not excavated. Top of the storage tank should be at least 6 in. in thickness. A brick or concrete wall not less than 12 in. in thickness should be constructed around the storage tank, extending from bottom of tank up to top of tank. The space between the top of the tank and the sidewalk should be filled with earth, the earth covered with the sidewalk. Flooring at bottom of tank optional.

All tanks should be of steel construction, thickness of plates as follows: Up to 5000 gallons, 3/16 in. shell; 5000 to 10,000 gallons, 3/16 in. shell, with 5/16 in. heads; 10,000 to 20,000 gallons, 1/4 in. shell, with 3/8 in. heads. Over 20,000 gallons tanks must be of standard specifications for oil tanks.

The situation of the oil storage depends largely upon the kind of tank. Steel and galvanized iron tanks are generally constructed on the surface, the oil flowing by gravity to the oil pumping system, having been pumped from supply cars to the storage tanks.

Galvanized sheet iron tanks are sometimes placed under ground, though this practice is not to be recommended because of the pressure caused by the surrounding earth. Corrugated iron tanks with the corrugations running around the tank are many times stronger than plain tanks and can be safely placed underground.

Re-inforced concrete tanks are used in many places. Great care must be taken in their construction, using only the best cement and clean sand. The bottom should be on a 3 in. bed of oil sand and the in-

side should be finished with at least  $\frac{1}{2}$  in. of cement, and coated with a good waterproof solution.

The size of the storage tank depends upon the estimated consumption of oil. If the plant is a great distance from the source of supply, a storage equal to at least one month's requirement should be constructed.

When the storage is far from the furnaces, it should be arranged to allow the oil to flow by gravity. It is better to pump the oil into the storage than tax the pumps to their capacity by pumping from the storage to the burners. Large suction lines from storage to the pumps are recommended, the diameter of the suction being from 1 to 2 in. greater than the pump suction.

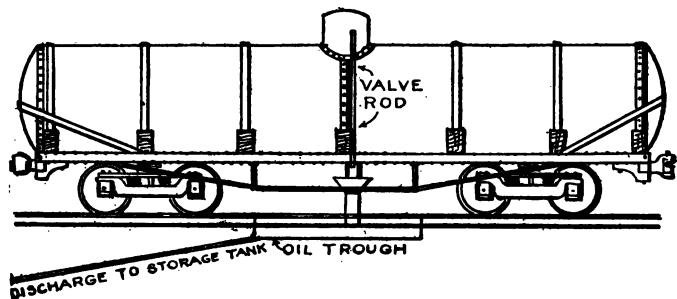

Fig. 5. Gravity Method of Unloading Tank Car.

When necessary to heat the oil in the storage tank, this can be best accomplished by 2 in. heating coils, placed near or around the suction, inside of the tank. Pipes through the tanks should be connected by companion flanges securely fitted to the shell, and not a running nipple secured with lock nuts.

Fig. 5 shows the method of unloading a tank car by gravity. Wherever possible a "trough" should be constructed to allow the oil to flow into the storage tank as it obviates the necessity of making pipe connection each time a car is unloaded and prevents the loss of oil before the connection can be made after the valve is opened when some foreign substance has collected under the bottom valve.

Fig. 6 shows the method of pumping the oil from the tank car. In cool weather it is often necessary

to heat the oil, and in tank cars having no heating coils; steam connections are made as shown.

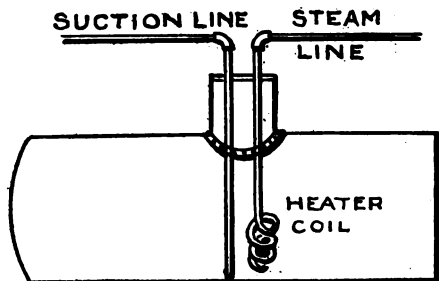

Fig. 6. Connection for Pumping Oil from Tank Car.

Fig. 7 shows how a tank car is unloaded by means of compressed air. Care should be taken in using this method as many of the tank cars are only tested to 50 lb. pressure per square inch.

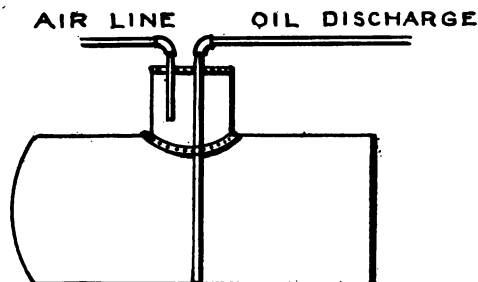

Fig. 7. Compressed Air Oil Pumping from Tank Car.

A swing joint and strain should be fitted to the suction line entering the tank; the length of the "swing" being equal to the depth of the tank. The strainer can thus be cleaned after it has been pulled to the opening in the top of the tank. A small drain is necessary at the bottom edge of the tank to drain off the water that settles. A manhole on the top and also at the bottom side is of great advantage when cleaning. Vent pipes must be also provided to allow for the escape of any gas that might form.

The use of naked lights around the storage tanks should be absolutely prohibited. When using portable electric lights care should be taken to see that the in-

sulation is in good condition as otherwise an explosion is liable to occur in case of a spark, due to the wires grounding.

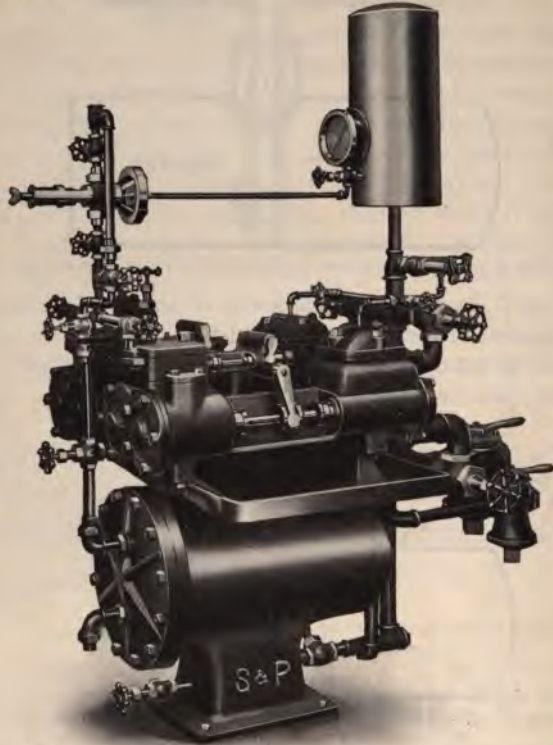

Fig. 8. S. & P. Fuel Oil Pumping System.

Many classes of pumping systems have been devised to handle the oil from the storage tank to the burners. As a rule they consist of two pumps mounted upon a bracket or base containing the oil heater which utilizes the exhaust steam from the pumps or live steam from the boilers, thus bringing the oil up to the required temperature. The pumps are set on a flat cast iron pan so arranged that they may be overhauled without allowing the oil or water to flow over the heater or fireroom, and deep enough to hold the

oil contained in the pump cylinders. An oil relief valve is placed on the discharge line and fitted so as to allow any excess oil to return to the tank.

Oil strainers are either fitted in duplicate or the self cleaning type is used. An air tank is placed on the discharge line to take up the pulsation of the pump, thus insuring a steady pressure. The pressure is also

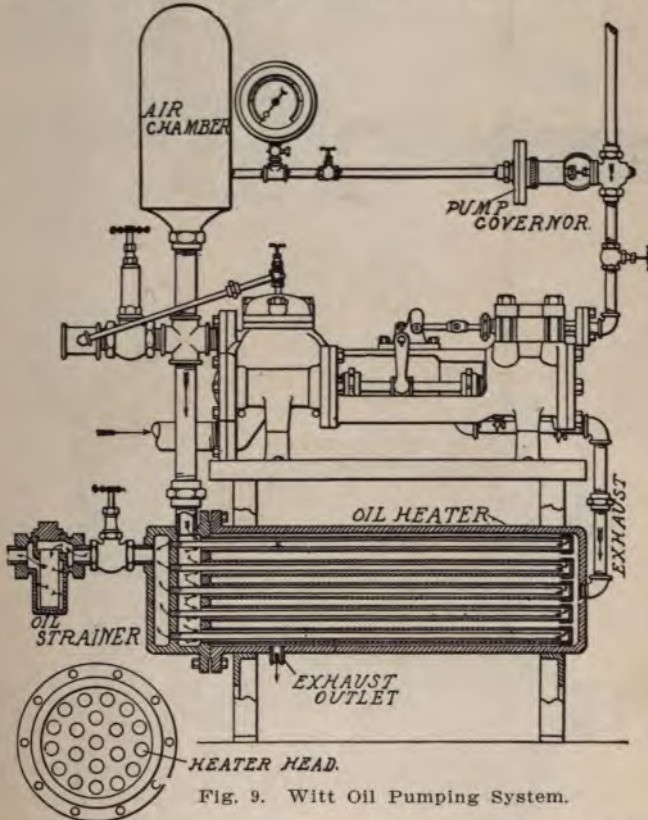
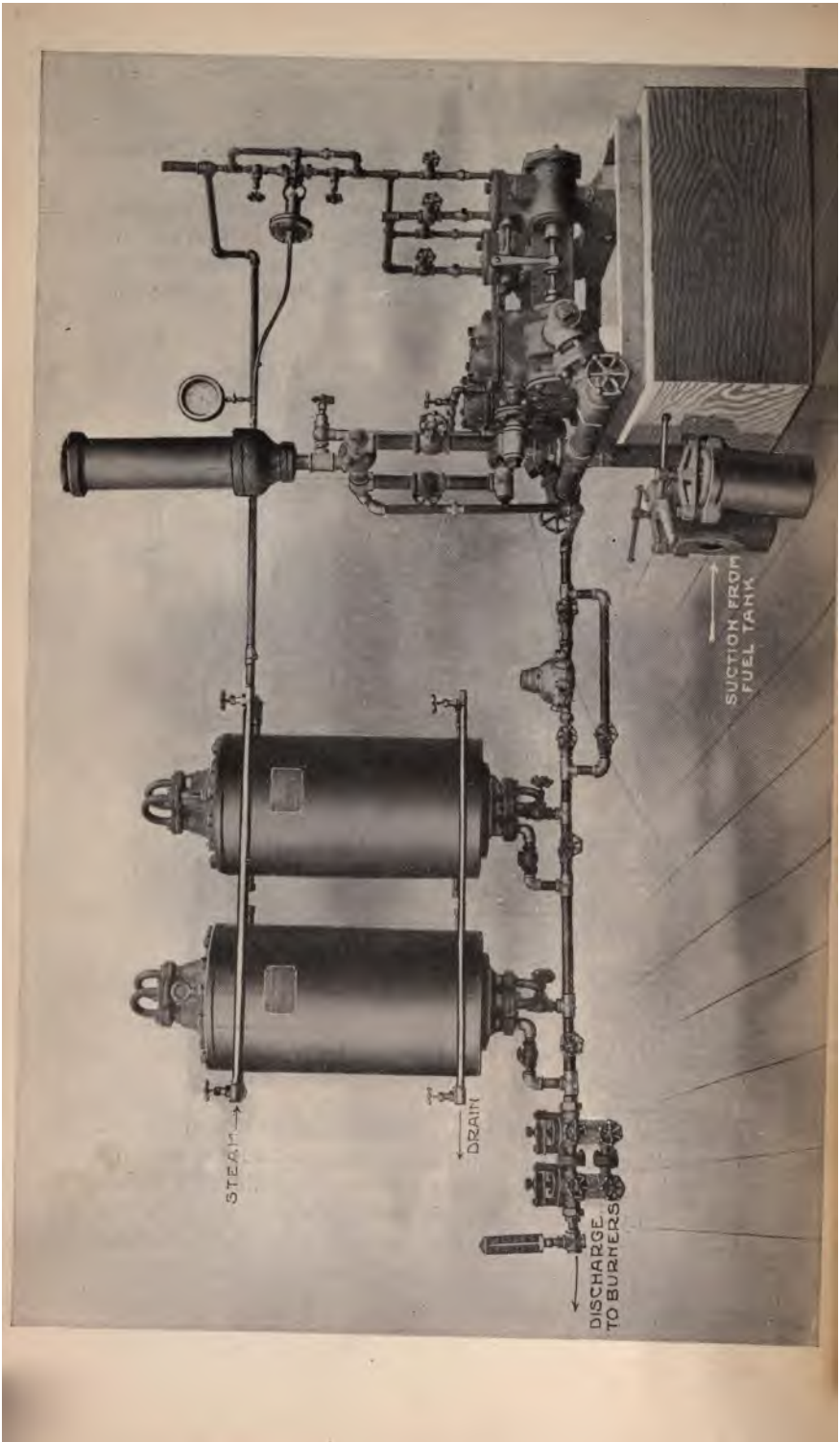

Fig. 9. Witt Oil Pumping System.

regulated by means of a pump governor fitted on the steam line to the pumps and connected to the oil line.

By an arrangement of valves and fittings either pump may be used, the oil passing either through the heaters or directly to the burners. Any gas formed in the oil chambers may be vented through proper



STEAM →

→ DRAIN

→ DISCHARGE TO BURNERS

← SUCTION FROM FUEL TANK



valves and gages and provided to show the pressure and temperature.

Fig. 8 shows a complete and very compact fuel oil pumping system. Fig. 9 shows a condensing type of oil heater.

Fig. 10 shows a pumping system and heater arrangement for a "mechanical" oil burner installation. Owing to the high pressures and temperatures used with mechanical systems, care must be taken to have all fittings of the best quality. Fig. 11 shows a low pressure heating system, used in kitchen ranges, hot water boilers, low pressure steam boilers, and hot air furnaces.



Fig. 11. Ray's Rotary System.

## CHAPTER III.

### BOILER FURNACE ARRANGEMENT.

The construction of the furnace for oil varies with the type of boiler and the class of burner used. It is the most important part of the installation, but until recently has received the least attention by the engineers. It is in the furnace that the proper combustion of the oil must take place. A slight difference in the amount of air admitted may mean a great loss of heat units. It is an easy matter to secure a smokeless fire, but efficiency can only be obtained by having a carefully designed furnace.

Fig. 12 shows the method of applying oil to a return tubular boiler employed by many engineers. It will be noticed that the air is supplied from the rear end of the boiler, and is compelled to travel the entire length of the furnace, under the grate, before entering the combustion chamber. Thus the air is pre-heated before entering the fire box. Fig. 13 shows a patent furnace arrangement, with the burner placed at the back end of the furnace. This type of furnace has been successfully applied to water tube boilers of various designs. Fig. 14 illustrates the burner and furnace arrangements for the Coen system as applied to B. & W. marine boilers. It will be noticed that the regular coal firing doors have been moved from the furnace front, and special air regulating fronts substituted. The burners are located as shown, one in each doorway, and the main flow of air for combustion is regulated by a sliding plate surrounding the burner. Auxiliary air is admitted through the ash pit doors.

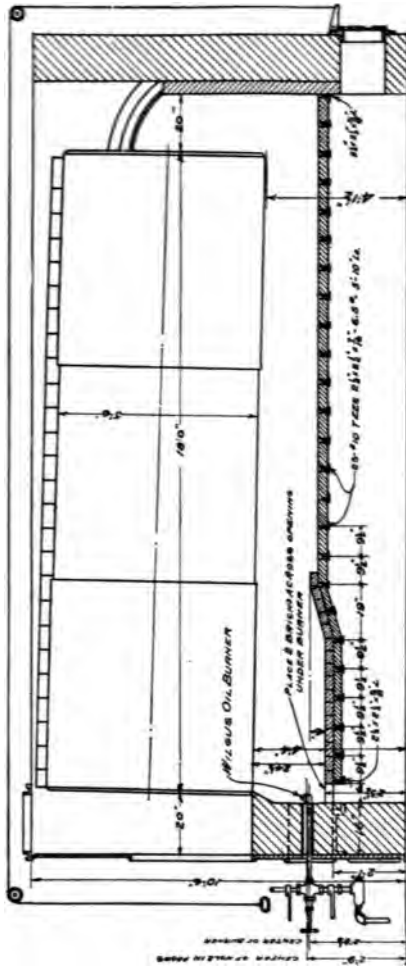

Fig. 12. Setting for Wilkus Burner Under Return Tubular Boiler.

An important feature of the interior furnace arrangement is the provision for a current of insulating air to circulate from the back to the front end of the furnace, between the ash pan and the furnace deck. This is accomplished by cutting two air openings of sufficient area in the back of the furnace and constructing an air duct  $2\frac{1}{2}$  in. in height, running from

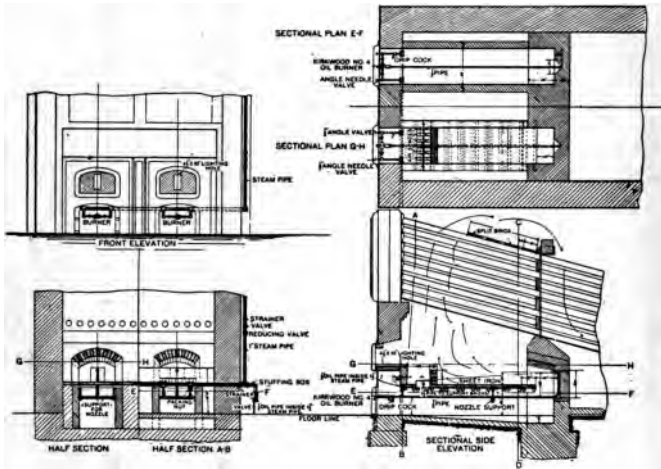

Fig. 13. Setting for No. 4 Kirkwood Burner Under Water Tube Boilers.

front to back the full width of the furnace. When these rear doors are open, which is the case only when the fires are in operation, a current of air is admitted which travels rapidly forward through the ducts, entering the combustion chamber through the firing arches in front of the burners. This circulating air serves a double purpose; it affords perfect insulation between the ash pan and the furnace, and provides the furnace with preheated air, which is an important aid to rapid combustion.

Fig. 15 shows the furnace arrangement under the Parker boiler. The former grate bar level has not been changed; a layer of fire brick properly spaced over the grate bars was all that was necessary to change to oil fuel.



Fig. 16 illustrates another furnace arrangement for a B. & W. boiler. The grate bars are lowered a few inches and then covered with a layer of fire brick. In spacing the fire brick, it is common practice to leave out one whole brick about five inches in front

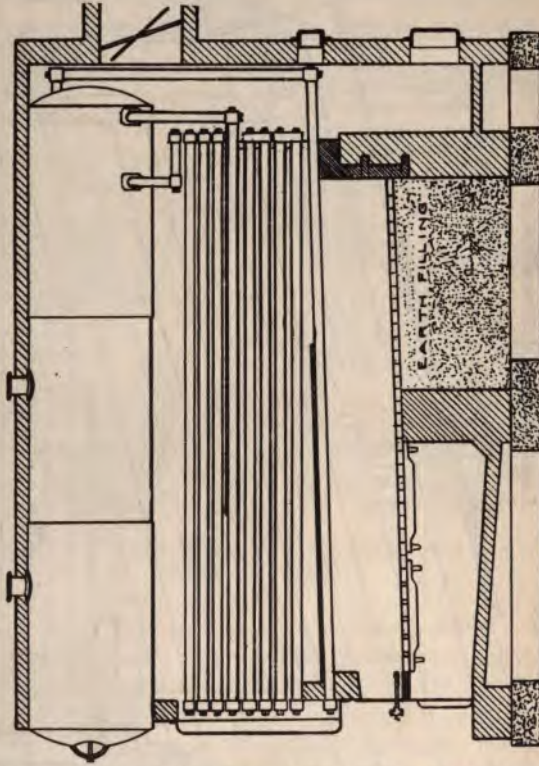

Fig. 15. S. & P. Furnace Arrangement Under Parker Boiler.

of the burner. The other bricks, for a distance of three feet from the front, are left about one inch apart allowing the air for combustion to pass up and through the flame. The air is thus heated by coming into contact with the hot bricks. The spread and length of the flame can be regulated by the spacing of the fire bricks.

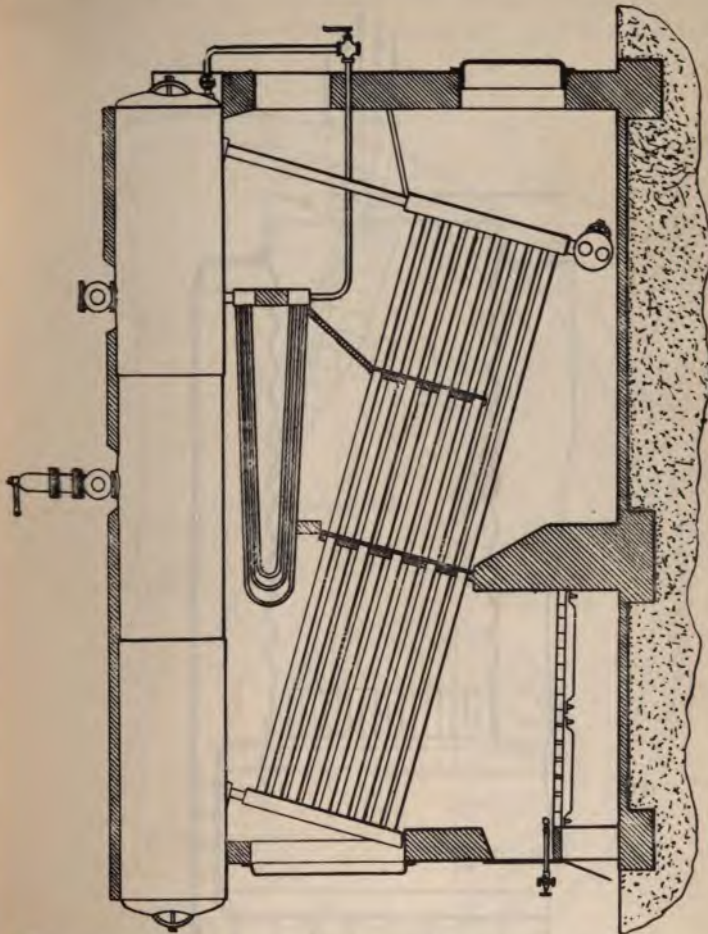

Fig. 16. S. & P. Furnace Arrangement Under B. & W. Boiler

Fig. 17, 18 and 19 show the general arrangement of the S. & P. burner as applied to the Scotch marine boiler. The grate bars are entirely removed, as are the bridge wall and front dead plate. A ring of fire brick is fitted in the throat of the furnace and a number of old grate bars are placed on an incline. On account of the round shape of the furnace they are cut off as

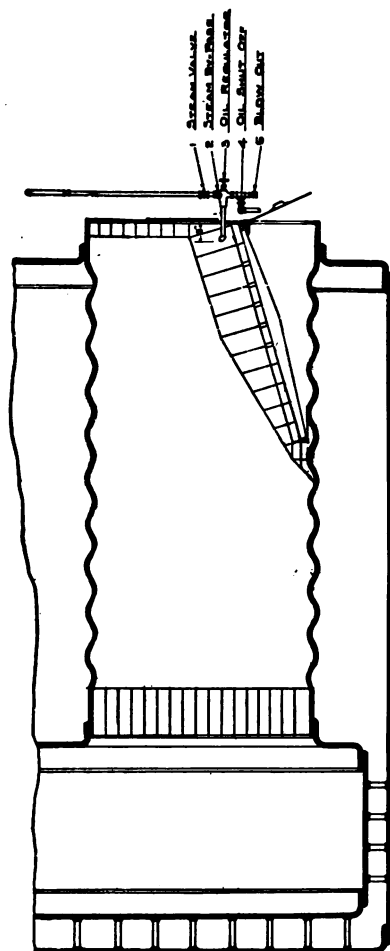

Fig. 17. Longitudinal View of Burner Arrangement for Scotch Marine Boiler.

shown in Fig. 18. A single layer of fire brick is placed over these bars and spaced as shown in Fig. 19. When forced draft is used the openings 1 and 2 are closed. The necessary air is regulated by the damper C. The burner is placed as shown, generally five inches above the fire brick. This type of furnace ar-



angement has been used with great success by many of the large steamship companies operating on the Pacific Coast.

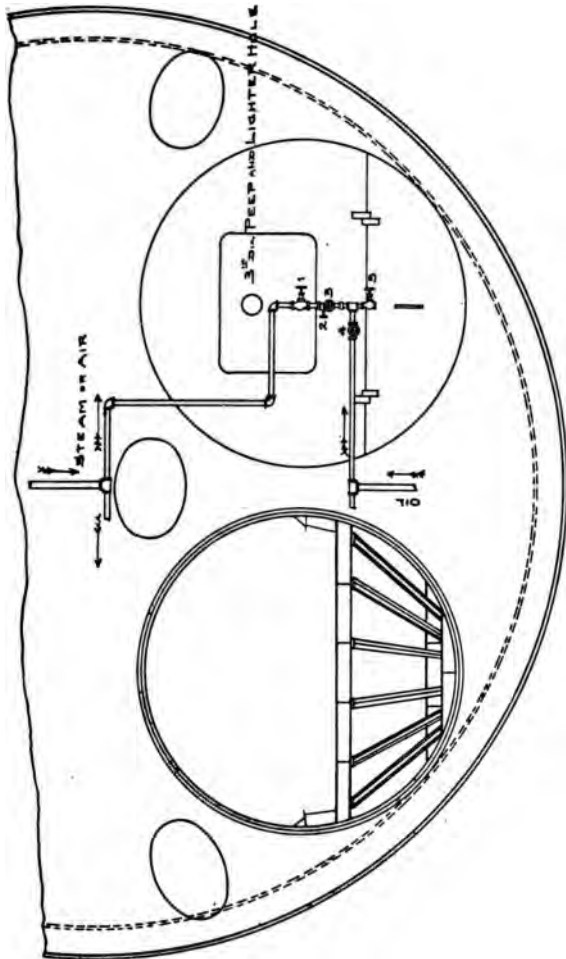

Fig. 18. Cross Section of Burner Arrangement for Scotch Marine Boiler.

Fig. 20 shows the application of a Wilgus oil burner to an upright boiler. A 3 in. tube is expanded

through the water leg of the boiler, in which the burner is placed. A ring of fire brick about 14 in. in height is placed around the sides of the furnace; fire brick are also placed about 1 in. apart on top of the

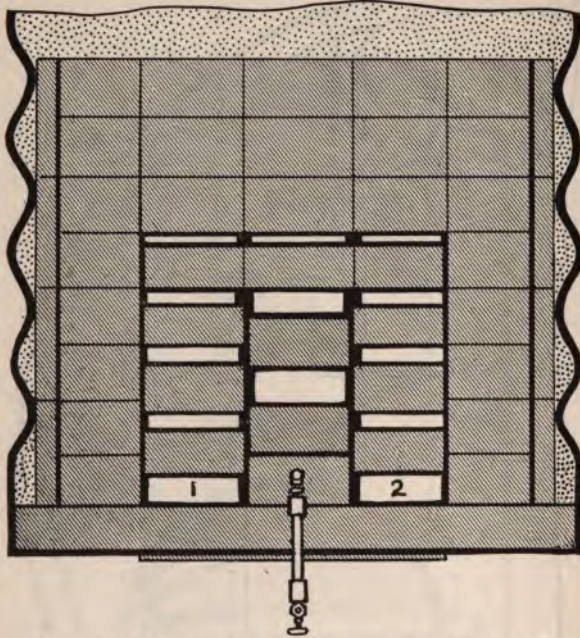

Fig. 19. Fire Brick Arrangement for Oil Burning for Scotch Marine Boiler.

grate bars. By this arrangement the boiler can readily be used for wood or other fuel, by simply removing the burner. Many plants burning oil use this type of boiler for getting up steam required for pumping systems and burners operating the main boilers, after having been closed down on Sundays or holidays.

Much better furnace efficiency can be secured by having an oil burning expert inspect the furnaces when a change to oil fuel is contemplated. Such an expert will design a furnace front without expensive grate bars, bearing bars, or other fittings that a salesman might be anxious to install, and at the same time

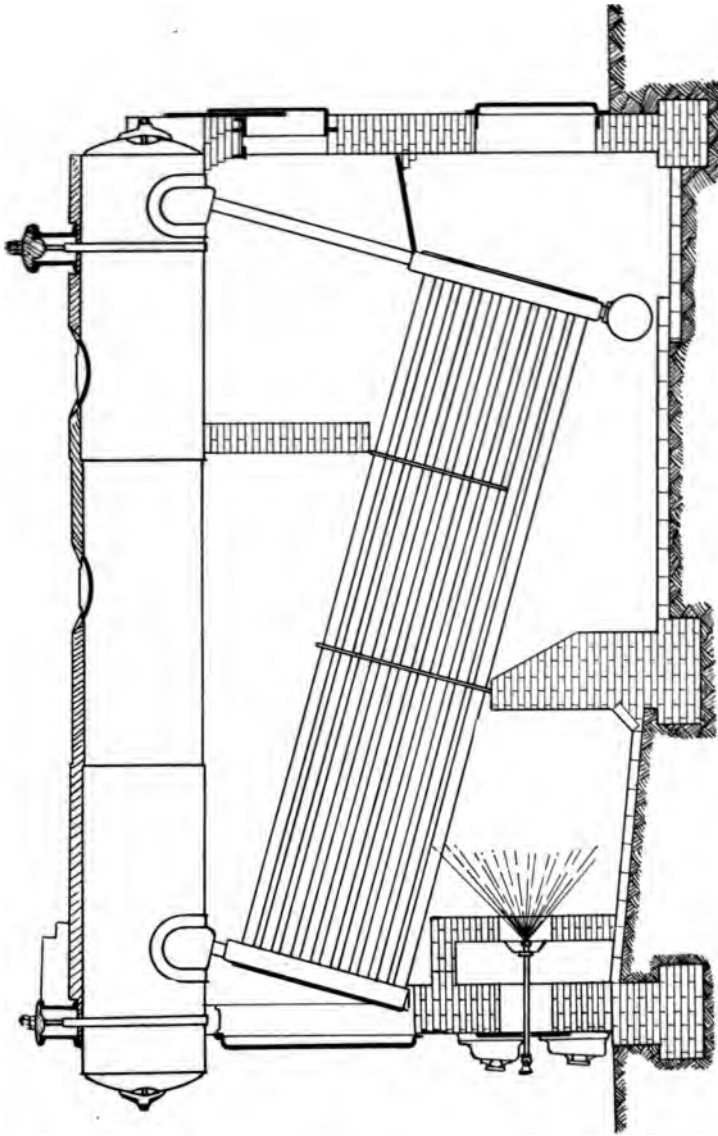

Fig. 20. Arrangement of Furnace and Brickwork for Babcock & Wilcox Water Tube Boiler (Stationary Type) with Dahl Mechanical Oil Burner.

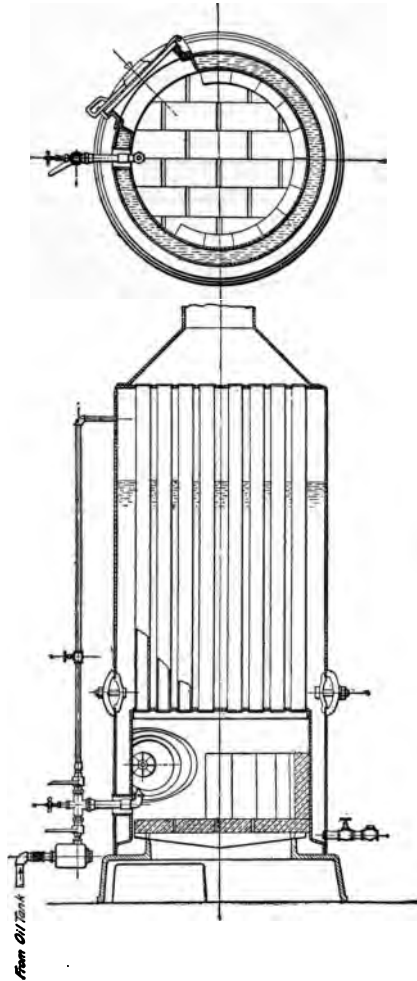

Fig. 21. Wilgus Burner Arrangement for Upright Boiler.

provide a furnace from which the highest efficiency may be secured. The vital importance of correct design and construction of furnaces will be further emphasized in a chapter on combustion.

The required height of chimney for fuel-oil plants is much less than is ordinarily supposed when the

boilers are operating at or below their rated capacity, and considerably greater than is usually supposed when there are heavy over-loads. As pointed out by Mr. C. R. Weymouth, of San Francisco, Cal., in a paper read before the American Society of Mechanical Engineers, a chimney of undue height will take an excessive quantity of air for combustion and permit an excessive load on the boilers, both resulting in a large waste of fuel. When the chimney height is limited to that necessary for economical air supply at the desired boiler load, it will be impossible for the most careless fireman to cause serious waste of fuel, either by supplying excessive air, or seriously overloading the boilers. The chimney may thus become an important and inexpensive means of regulating boiler-plants, and an automatic safeguard against careless firing. Such service is, of course, most successfully secured only in plants operating at uniform load.

The San Francisco earthquake of April 18, 1906, considerably reduced the height of most masonry chimneys, and resulted in an extensive collection of chimney data. Many of the results obtained apparently were contradictory. Certain chimneys, reduced to a height of 30 ft., gave the usual boiler capacity; and others, reduced only to a height of 75 ft., showed under certain conditions of service a decrease in boiler capacity.

Altitude has an important bearing on chimney design. The error commonly made in the determination of stack capacities at high altitudes is to assume that a given grade of fuel at a fixed boiler rating will require at high altitude the same draft, measured in inches of water at the damper, as at sea level. It is evident that to develop a given boiler horsepower requires a constant weight of chimney gases and air for combustion. As the altitude is increased, the density of the air is increased, and, correspondingly, its velocity through the furnace, the bed of coal, or the fire brick checkerwork. The boiler passes must therefore, be greater at high altitude than at sea level. The mean velocity for a given boiler horsepower and con-

stant weight of gases will be inversely proportional to the barometric pressure. And the velocity head, measured in column of external air, will be inversely proportional to the square of the barometric pressure.

For chimneys built at high altitude it is necessary to increase not only the height, but also the diameter. The increase in height causes an added frictional resistance within the chimney; this frictional loss must be compensated by a suitable increase in the diameter, and when so compensated it is evident that the chimney height must be increased at a ratio inversely proportional to the square of the normal barometric pressure.

Based on 150 per cent as the ratio of actual boiler h.p. to rated boiler h.p. and assuming sea level atmospheric pressure and 80 degrees F., the author presented the accompanying table of approximate maximum capacities measured in actual boiler h.p. These data apply to steel chimneys with short flues, the chimneys being centrally located over stationary B. & W. boilers. Other conditions are: Draft in inches at boiler outlet, chimney side of damper, 0.30; corresponding excess air through boiler, per cent, less than 50; assumed excess air supply for determining boiler efficiency, chimney diameter and draft resistance of chimney and breeching, per cent, 50; assumed temperature of gases leaving boiler, 525 degrees F.; assumed temperature of gases entering chimney, 500 degrees F.; assumed boiler efficiency, working not test conditions, 73 per cent; assumed pounds of chimney gases per actual boiler h.p., 54.6:

**BOILER FURNACE ARRANGEMENT**

**Table of Approximate Maximum Capacities (Actual Boiler h.p.) for Oil-Burning Chimneys (Boilers 150 Per Cent Rating)**

Diam. eter,	Area, Sq.	Height in Feet Above Boiler-Room Floor Line.									
		80	90	100	110	120	130	140	150		
18	1.77	63	75	84	91	96	101	104	108		
21	2.41	90	108	121	131	139	146	151	156		
24	3.14	123	148	166	180	191	201	208	215		
27	3.98	161	195	219	238	253	265	276	286		
30	4.91	206	249	280	304	324	340	354	366		
33	5.94	256	310	349	381	405	426	444	459		
36	7.07	312	379	427	466	497	523	545	564		
39	8.30	376	455	514	561	599	631	657	681		
42	9.62	448	539	609	665	711	749	782	810		
45	11.05	518	630	713	779	834	879	918	952		
48	12.57	599	729	827	904	967	1,020	1,070	1,110		
54	15.90	779	951	1,080	1,180	1,270	1,340	1,400	1,460		
60	19.64	985	1,200	1,370	1,500	1,610	1,710	1,790	1,860		
66	23.76	1,220	1,490	1,700	1,860	2,000	2,120	2,220	2,310		
72	28.27	1,470	1,810	2,060	2,260	2,430	2,580	2,710	2,820		
78	33.18	1,750	2,150	2,460	2,710	2,910	3,090	3,250	3,380		
84	38.49	2,060	2,530	2,900	3,190	3,440	3,650	3,840	4,000		
90	44.18	2,390	2,950	3,370	3,720	4,010	4,260	4,480	4,670		
96	50.27	2,750	3,390	3,880	4,290	4,630	4,920	5,180	5,400		
102	56.75	3,140	3,870	4,440	4,900	5,290	5,630	5,930	6,190		
108	63.62	3,550	4,380	5,020	5,550	6,000	6,390	6,730	7,030		
114	70.88	3,990	4,920	5,650	6,250	6,760	7,200	7,590	7,930		
120	78.54	4,440	5,490	6,310	6,990	7,560	8,060	8,490	8,890		
126	86.59	4,930	6,100	7,020	7,770	8,410	8,970	9,460	9,900		
132	95.03	5,450	6,740	7,760	8,600	9,310	9,930	10,500	11,000		
138	103.90	5,990	7,420	8,530	9,460	10,300	10,900	11,600	12,000		
144	113.10	6,550	8,120	9,350	10,400	11,200	12,000	12,700	13,300		
156	132.70	7,760	9,630	11,100	12,300	13,400	14,300	15,100	15,800		
168	153.90	9,060	11,300	13,000	14,400	15,700	16,800	17,700	18,600		
180	176.70	10,500	13,000	15,100	16,700	18,200	19,900	20,600	21,600		

## CHAPTER IV.

### OIL BURNERS.

The history of oil burners dates from the early part of the last century. Records of improvements have been kept by various writers and the patent office. Such writers on oil fuel as Brannt, Booth, North, Hodgetts, Lewes, Percy, Henry and Goulichambaroff, have described in detail the successes and results obtained by the inventors.

Various types of oil burners are illustrated, in order that the reader may have an idea of the methods adopted by the inventors to atomize the oil. These burners are in successful operation in plants visited by the author in various parts of the world.

Fig. 22 shows the W. N. Best oil burner. This is termed an outside mixer because of the fact that the mixing takes place at the outer tip of the burner.

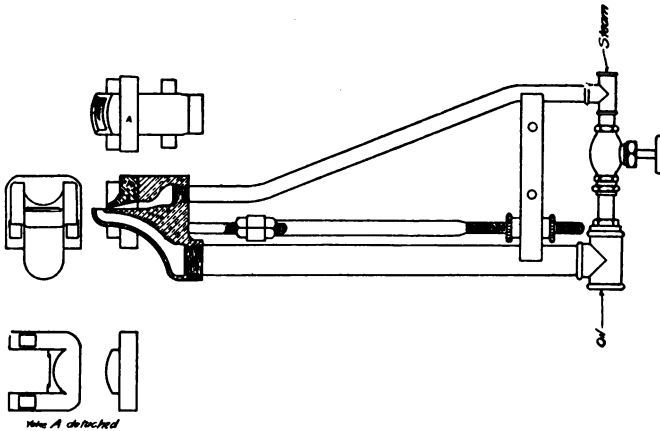

Fig. 22. N. N. Best Burner.



A siphoning action draws the oil from the lower tube, and it is atomized by the steam with which it comes in contact at the top of the tube. This burner has been known to burn tar as well as oil.

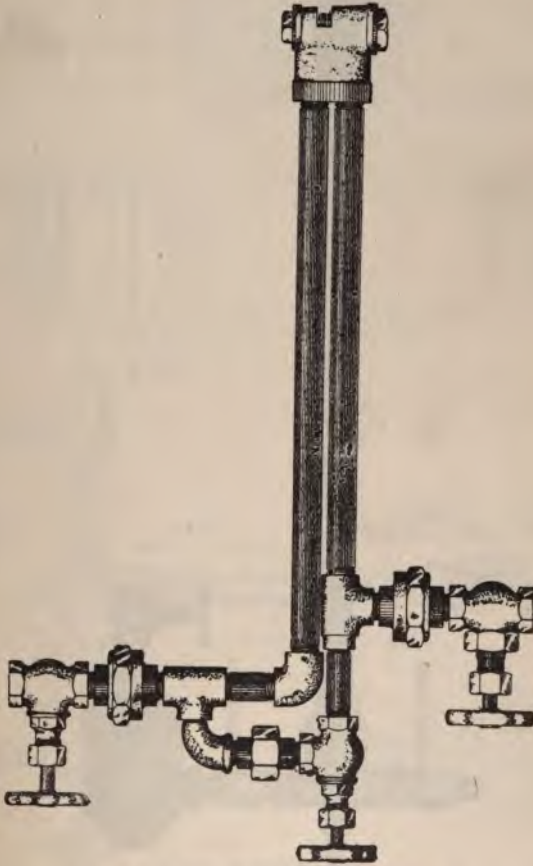

Fig. 23. Witt Gravity Oil Burner.

Fig. 23 shows the Witt gravity oil burner which is also of the outside mixing type. The oil flows over a flat spray of steam coming from the bottom tube as it passes through the upper tube to the tip, which

contains a flat slot. Fig. 24 shows the Wilgus oil burner, which operates much the same as the Wit burner. Fig. 25 shows the Hammel oil burner which



Fig. 24. Wilgus Oil Burner.

is similar in some respects to the Best burner, but differs in the slot arrangement, and also in the fact that the mixing takes place in the inner chamber. By

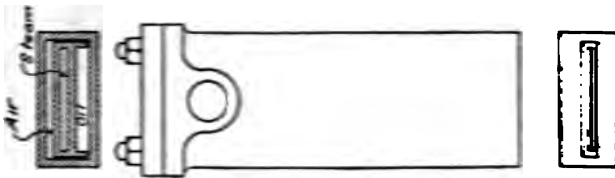
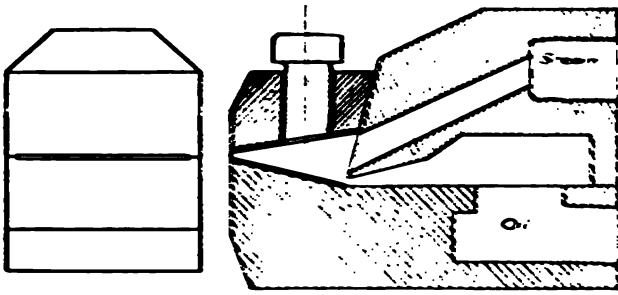

Fig. 25. Hammel Oil Burner.

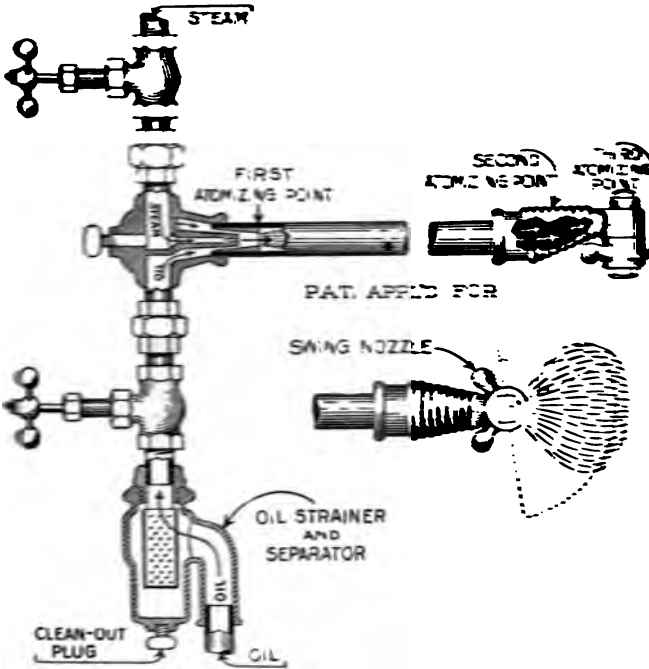

Fig. 26. Schur's Oil Burner.

means of a small steel plate, the jet is sprayed over a large surface.

Fig. 26 shows the Schurs oil burner, which has been designed to atomize the oil at three different points. The first atomizing point breaks up the oil.

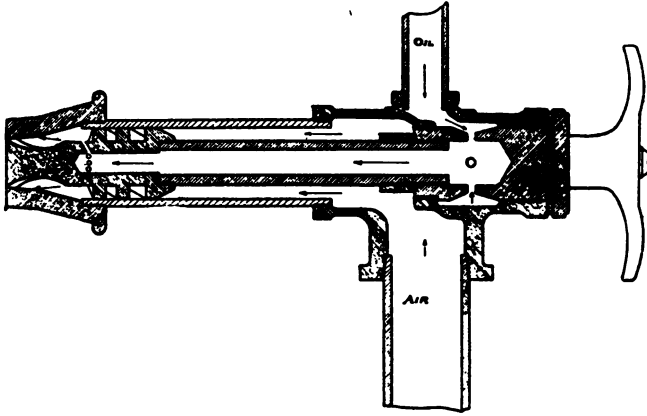

Fig. 27. Grundell-Tucker Oil Burner.

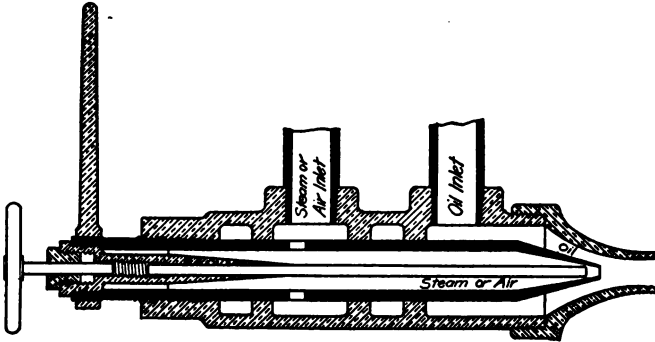

Fig. 28. Heresoff Oil Burner.

The tube superheats the spray, and the second atomizing point breaks it up into a finer and more perfect mixture. At the third atomizing point or tip the spray forms into a flat stream; this third point acts as a carburetor, changing the spray to a vapor.

Fig. 27 shows the Grundell-Tucker oil burner. The burner consists of a fitting having an internal

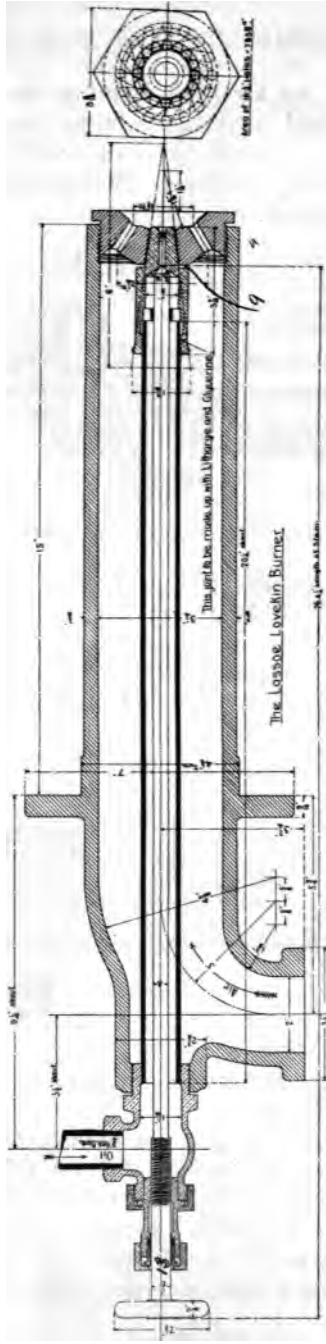

Fig. 29. Lasso-Lovekin Oil Burner.

dividing wall. An air pipe forming the shell of the burner is screwed into the mixing head; this head has a number of spiral grooves which give to the mixture a whirling motion. The burner is operated with compressed air.

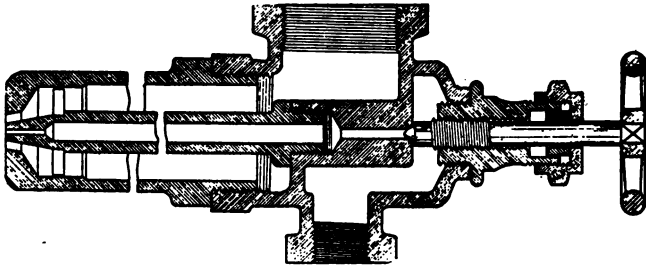

Fig. 30. Fitzsimmons Oil Burner.

Fig. 28 shows the Hereshoff Oil Burner, designed to operate with either steam or air. Fig. 29 shows the Lassoe-Lovekin oil burner. This consists of an air tube, and a centrally located oil tube passing to the tip. The latter is provided with a series of con-

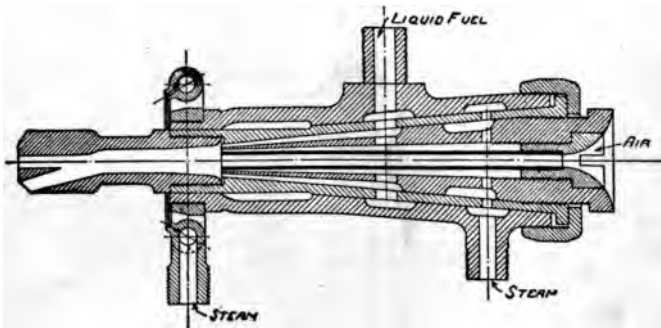

Fig. 31. Holden Oil Burner.

verging, helically arranged jet apertures around the oil nozzle. Passing through the oil tube is a regulating rod tapered at the end to spray the oil in conical form. This burner is operated with an air pressure of 14 ounces. Fig. 30 shows the Fitzsimmons oil burner, a very simple type. Fig. 31 shows the

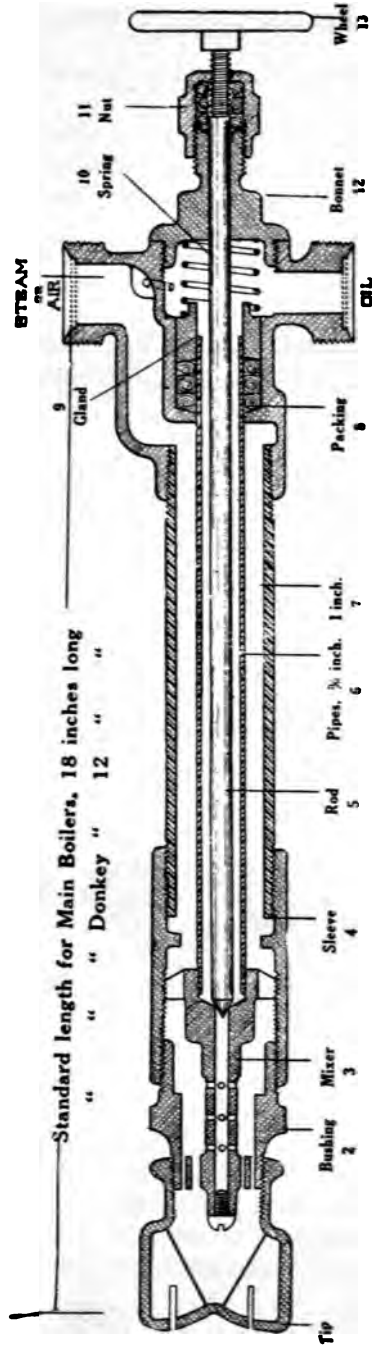

FIG. 32. Staples & Pfleffer Oil Burner.

Holden oil burner, designed to operate with steam and air.

Fig. 32 shows the Staples & Pfeiffer oil burner, Oil, and steam or air, are passed through an inner and an outer tube, and through specially arranged perfora-

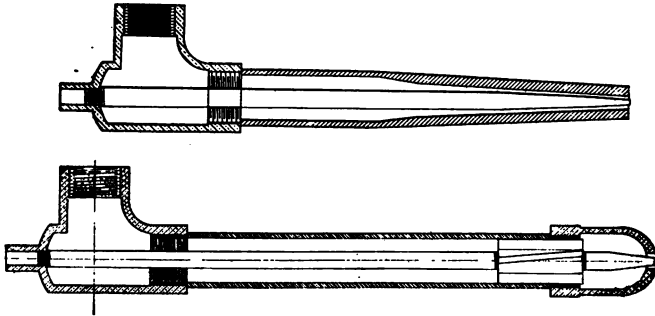

Fig. 33. Jarvis Oil Burners.

tions to a mixing chamber, whence the mixture passes through other perforations and channels to a head, containing baffling plates, finally escaping through the openings. The various openings are not in line with one another, so that the stream is broken up. The oil



Fig. 34. M. & W. Rotary Oil Burner.

tube contains a regulating spindle with a pointed end fitting the conical end of the tube, which itself serves as a valve to regulate the supply of oil.

The oil enters the mixing chamber through radial perforations, or inclined ones, the issuing streams, in



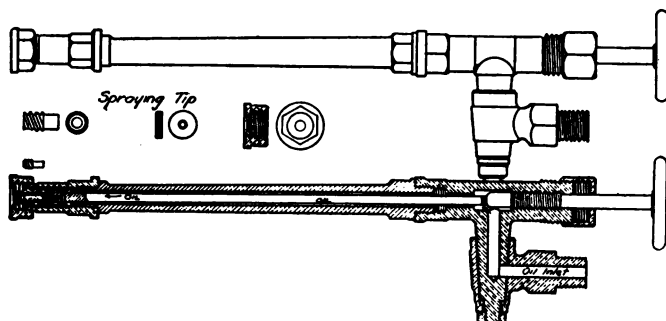

Fig. 35. Mechanical Burner Used in Baku Oil Fields.

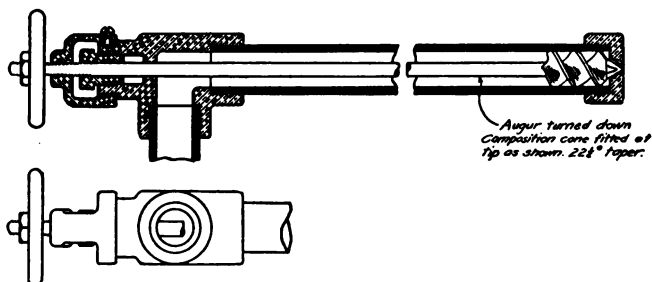

Fig. 36. Naval Fuel Oil Burner.

either case, being broken up by opposing surfaces. The steam or air enters the mixing chamber through passages, parallel to the axis of the tubes. The channels through which the mixture escapes to the burner head may be formed as slots in an enlargement at the end of the oil tube. These chambers are especially arranged.

Fig. 33 shows a number of low pressure oil burners made by T. P. Jarvis. Fig. 34 shows the M. & W. rotary oil burner. This oil burner was tried out by the U. S. Naval Board. Fig. 35 shows a mechanical burner used in the Baku oil fields of Russia. The spraying is effected by two sets of spiral guide blades, one set within an inner tip and one within the outer tip. The outer spraying tip is removable, so that as the edges wear, new tips can be inserted, or special tips can be placed for use under certain pressures or

temperatures of the oil. Fig. 36 shows the naval fuel oil burner, devised to operate by mechanical action. Modern types of mechanical oil burners showing the furnace arrangements will be treated later.

A close inspection of the various types of oil burners illustrated, will show clearly that it is necessary to heat the oil in order to properly atomize it. Experiments have proven that fuel oil will not burn in a solid mass, but that it must be broken into minute particles by heat and mechanical action, and then immediately exposed to air.

Heating the oil lowers its viscosity, with the result that any suspended water more readily separates out.

A temperature of about 125 degrees has been found to produce the best results. When oil is heated above the flash point, trouble occurs. The carbon will precipitate and settle in the pipe lines and at the burner tip. There is also a danger of explosion, if there are any leaks in the oil line. When the oil is heated before reaching the burner, less air or steam will be required to atomize it. This is an important point, for it has been proven in practice that burners require at least 3 per cent for perfect atomization, and many burners are in practice using from 5 to 10 per cent.

Air pressures as low as 10 ounces are at present being used with excellent results under especially constructed furnaces.

Compressed air has been found more economical than steam as an atomizing agent in brick, lime and cement plants, where the units are a long distance apart.

In many cases the cost of installing and operating an electrically driven air compressor is much less than that of installing and operating steam boilers. The losses due to condensation are also avoided.

Many plants are fitted with burners that have to be forced to get sufficient steam from the boilers. This is bad practice, for when a burner is forced, excessive amounts of steam are required for atomizing.

Incomplete combustion and high stack temperatures, with their attendant losses, are bound to occur, and by forcing the burner and centralizing the heat, tubes and sheets may be blistered.

For all these reasons, the greatest economy can only be secured by installing an ample number of burners to supply all the fuel needed by the furnaces without forcing.

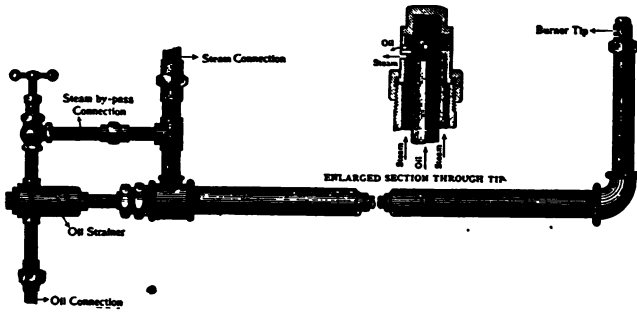

Fig. 37. Peabody Oil Burner.

## CHAPTER V.

### STRAINERS AND HEATERS.

All fuel oils carry a certain amount of foreign matter in suspension. Some of the impurities settle out while the oil is in the storage tank; but if the oil is heavy and viscous, much of the foreign matter will remain in suspension and be pumped to the burners unless a strainer is provided. Since most burners

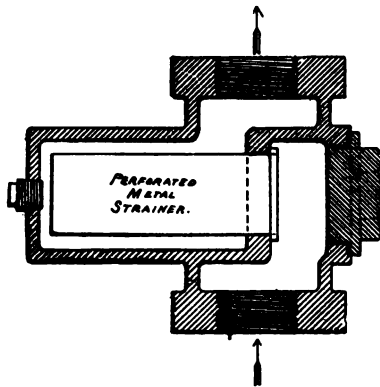

Fig. 38. A Simple Basket Type of Oil Strainer.

break up or atomize the oil by forcing it through small orifices, it is essential that there be an efficient strainer in the oil feed line, to remove all traces of gritty matter before the oil reaches the burner.

A good oil strainer must separate all solid matter suspended in the oil, and be large enough to retain the material removed for a considerable time, unless it is of a self-cleaning type.

Strainers are made in various sizes and shapes, a wire netting or perforated metal of some sort being

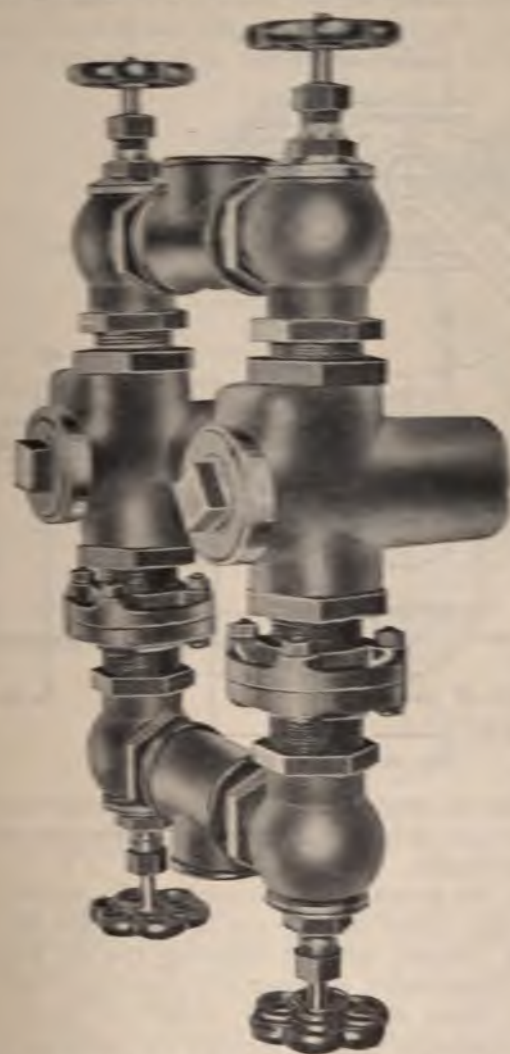

FIG. 39. Method of Connecting Bucket Heaters.

used to separate the dirt from the oil. A few are illustrated below, to indicate the various ingenious devices that have been contrived.

Fig. 38 illustrates a simple basket type of oil strainer. This type is cleaned by removing the plug at the top, taking out the basket, and rinsing it with kerosene. Fig. 39 illustrates the method of connecting a set of basket strainers. It is necessary to con-

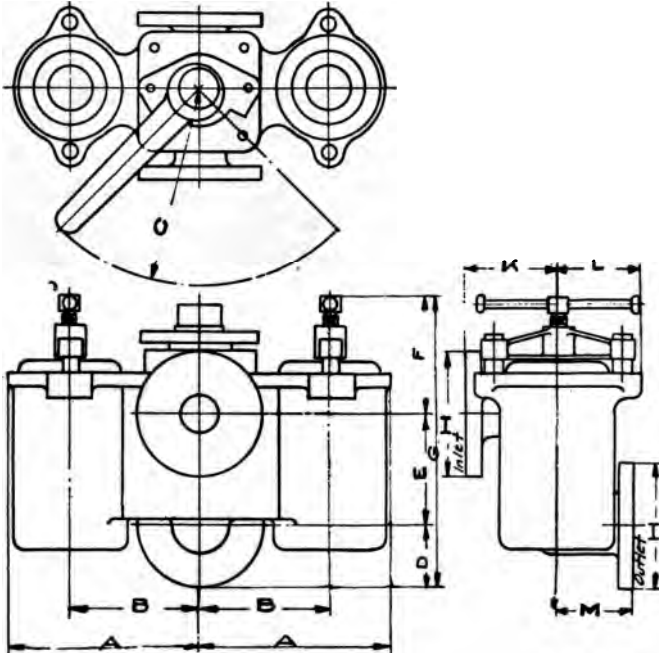

Fig. 40. Duplex Type of Strainer.

nect them in duplicate as shown, to permit continuous operation of pumps and burners while one strainer is being cleaned.

Fig. 40 shows a set of duplex oil strainers and plug cocks. Either strainer can be used while the other is being cleaned, without affecting the oil pressure. Fig. 41 illustrates a compact self cleaning oil strainer. The oil passes to the center, down the central tube and is strained by passing through the perforated cone. The clean oil passes up to the exit, while the dirt settles at the bottom of the strainer. By opening the bypass valve, oil flows directly through the line. Then

by opening the valve at the bottom of the strainer the dirt can be forced out with steam, which is sup-

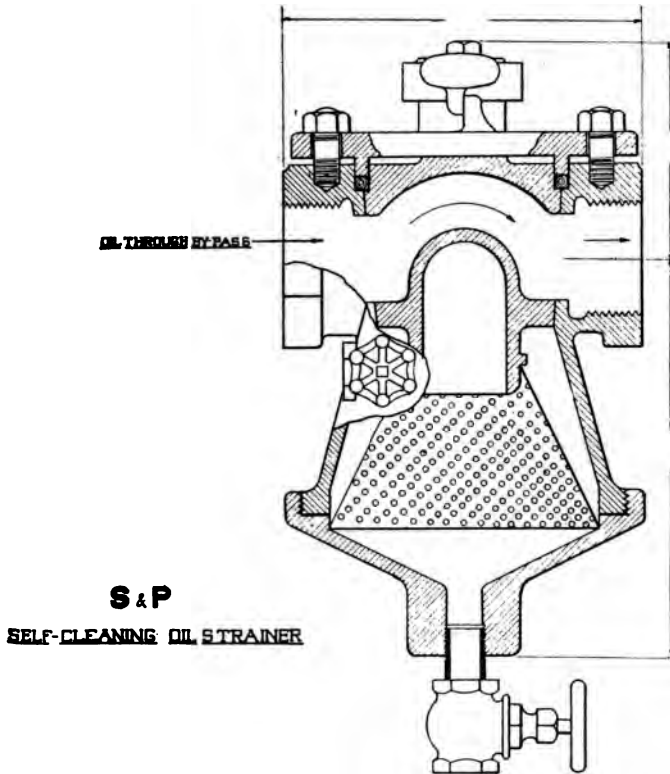

Fig. 41. Strainer for Suction Line of Pump.

plied by opening the small valve at the side of the strainer.

This type of strainer has many advantages. It can be operated and cleaned without soiling the hands, and is thus a time-saver. The flow or pressure of the oil is not changed while cleaning. And if a leak in the suction line causes difficulty in the operation of the pump, it can be readily located by closing the suction valve at the pump and opening the steam valve on the strainer. In this manner steam is forced into the suction line and the leak will be indicated by the

issuing steam. Heavy oil can also be heated in this manner when there is difficulty in starting the oil pump on a cold morning.

The object in atomizing the oil is to break it up into minute particles, and thus expose the maximum surface to contact with the air. This is accomplished in the burner, but to make the operation efficient, the

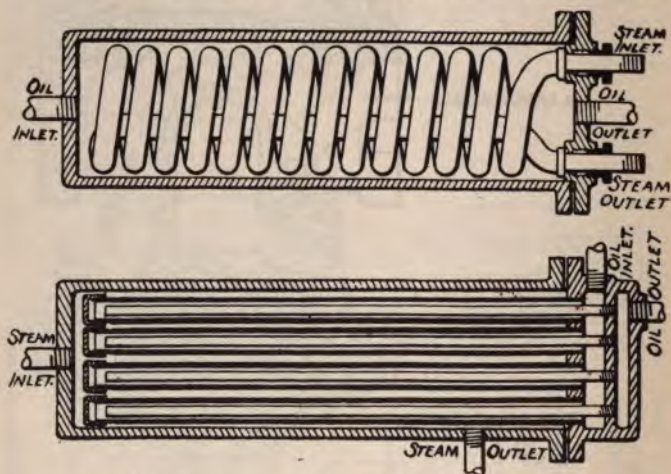

Fig. 43. Condensing Type of Heater, Showing Detail of Coil,

oil must first be heated. A further advantage of heating the oil lies in the fact that oil will burn more quickly at a high temperature, because the hydrocarbons are more readily separated. With the atomizing type of oil burner, the oil is heated to a temperature of about 125 degrees F. In the mechanical type, the temperature varies from 150 degrees to 220 degrees F.

A few of the many types of oil heaters in use, are illustrated herewith. The upper part of Fig. 43 shows a copper coil through which steam is circulated; the coil is submerged in a vessel through which the oil is pumped. The large heating surface of such a coil makes it an efficient type of heater. The lower part of Fig. 43 shows the condensing type of oil



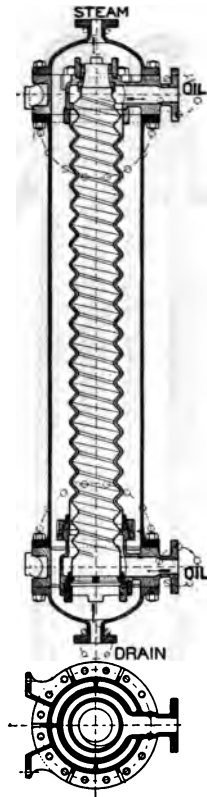

Fig. 44. Corrugated Metal Type of Heater.

heater. The oil passes through the oil inlet into a  $\frac{1}{4}$  in. pipe, which is enclosed by a  $\frac{3}{4}$  in. pipe. Upon reaching the end of the inner pipe it passes into and returns through the annular space between the inner and outer pipes to the discharge chamber. Steam fills the body of the heater and an outlet for the condensed water is placed at the bottom.

Fig. 44 illustrates a corrugated type of oil heater, in which the oil passes through the corrugated inner chamber and is heated by the steam that passes into the body of the heater. Fig. 45 illustrates a multiunit oil heater, constructed of extra heavy wrought iron pipe. The oil passes through the inner pipe and is



Fig. 45. Coen Multi-unit Oil Heater.

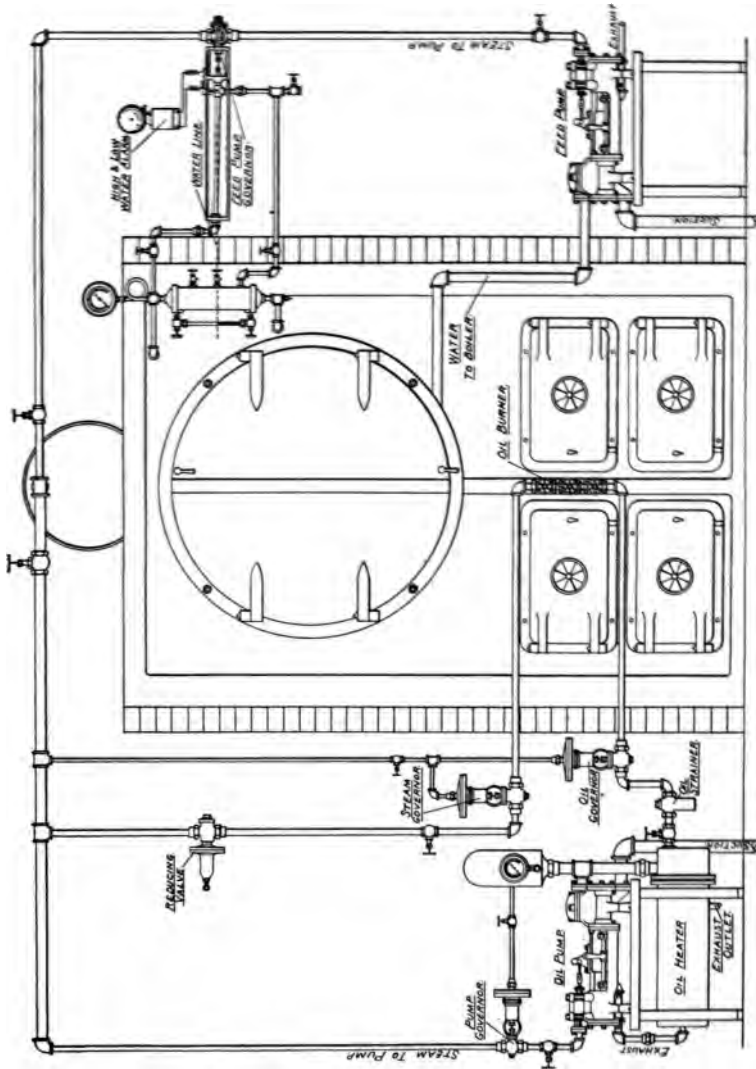

Fig. 46. Witt Automatic Regulator.

heated by the steam in the annular space between the two pipes. It will be noticed that all joints are made up on the outside. The return bends are extra heavy brass castings for the oil pipes and standard high pressure ammonia fittings for the steam connections. This type of heater can be made of as many units as may be required, and can be connected in duplicate so that either heater can be cut in or out, as desired.

Fig. 46 illustrates the method of applying automatic regulators to an oil burning system. The pressure of the steam is regulated by means of a governor that determines the amount of oil and steam fed to the burner. The operation is positive and simple. The regulator is set at the desired pressure and connected to the steam line from the boiler; a rise or fall in the steam pressure moves the diaphragm of the regulator, causing the spindle to open or close a valve, and thus regulating the supply of oil or steam to the burner.

Fig. 47 illustrates the method of connecting the Merit automatic fire and draft regulating system to a battery of boilers. A master control used with this system and designed to operate the regulators in accordance with load of the boiler.

Oil and steam are both present in the master control under pressure. Suppose the fires to be burning up to capacity and the steam gauge just registering maximum pressure. This steam pressure, acting on the master controller, causes it to operate the individual regulators which are distributed along the boiler front, one to each burner.

The regulators, acting under this particular influence, reduce the supply of oil and steam to the burners, diminishing the fires accordingly. At the same instant, both the ash pit and stack dampers are closed proportionately. Should the steam pressure still remain at its maximum, the master controller, after a proper time interval, operates to cause a still further reduction in the fires and drafts through the medium of the individual regulators.

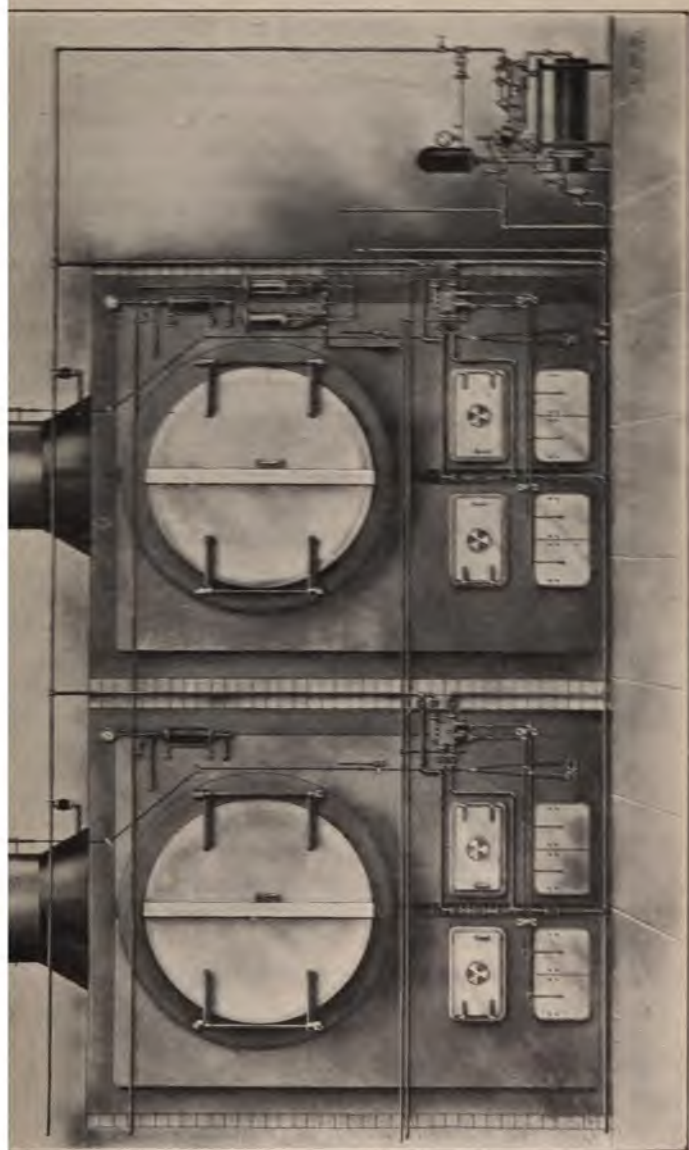

Fig. 47. Merit Automatic Fire and Draft Regulating System.

After this final operation the pilot fires are all that remain. The size of this fire has been regulated at the time of installation, so that it is just sufficient to take care of the reduction in each boiler.

To complete the above cycle: As soon as the steam gauge registers a pound drop, or more, if desired, the master controller reverses its operation and causes all the individual regulators to cut in the "first" fire. Simultaneously, the ash pit and stack dampers are opened the correct amount.

The size of this "first" fire is determined at the time of installation and is fitted to the particular requirements. Both steam and oil are regulated to the exact proportion and quantity, and once established these conditions are repeated day after day until other conditions require other settings.

New settings are readily made by simply turning keys in the individual regulators to vary the sizes of the orifices. At the same time the ash pit and stack damper settings are changed correspondingly. Very close adjustment of these can be made as a series of holes are provided in the operating levers by which the throw is changed in very small steps.

If after the "first" fire comes on the steam pressure does not build up, the master controller, after a proper time interval, causes the "second" fire to come on. This operation, like the first, simultaneously admits more oil and steam to the burners and more draft to the ash pit and flues.

This "second" fire may be also adjusted as readily as the first and its range extends from a fire slightly in excess of the "first" fire up to the capacity of the boilers.

In the above description it was stated that the draft and fires are changed simultaneously. This feature we believe is worthy of emphasis, and we are accordingly referring to it again.

This desirable feature is secured by having the stems of the valves, which regulate the flow of oil and steam to the burners, prolonged so as to engage the damper levers.

## CHAPTER VI.

### OIL IN THE CLAY, LIME AND CEMENT INDUSTRY

One of the important fields for oil as a commercial fuel is in kilns used in the manufacture of clay products. Enameled, vitrified, fire and common brick, sewer and water pipe, enameled sinks and tubs, cement, lime and ceramic ware of all kinds, as vases and dishes, are all more successfully made with oil than with any other fuel. The principal reason for this is found in the absence of any discoloration due to smoke, soot, or uneven heating.

Three types of kilns are commonly used: the up-draft kiln, the down-draft kiln and the muffle kiln. In the up-draft type the bricks or ware to be burnt are built in arch form in front of the furnace, and staggered throughout the kilns in order to receive an even distribution of the heat. The flame from the burner comes in contact with the brick near the furnace, and as a result a number of bricks become carbonized. Burners fitted to this type of kiln should give a long and narrow flame and many practical men recommend steam for atomizing. They should be adjustable to a low or heavy fire, and fitted with nipples and elbows in such a manner as to direct the flame to any position.

When water-smoking, the burner should always point downward. Because of the low flame required during this period, refractory material should be placed at the point of impingement of the flame, to assist in keeping the fire going and prevent kick-backs or explosions. For a heavy fire the burner should

be raised and the oil supply regulated to make a vibrating flame which has a tendency to force the hot gases to the center of the kiln and back to the head. When this is done, the articles in the kiln will be uniformly burned. Fig. 48 shows the correct method of fitting up a burner on an up-draft kiln.



Fig. 48. Burner for Up-Draft Kiln.

The following report was taken from the record of a prominent manufacturer of common brick in California:

Type of kiln .....	Common up-draft
Number of bricks burnt .....	300,000
Type of burner .....	Schurs
Pressure of steam at burner.....	90 lb.
Pressure of oil at burner.....	35 lb.
Temperature of oil at burner.....	95 deg. F.
Time required .....	126 hours.
Total oil consumed .....	307 1/7 bbl.
Total oil consumed for 1,000 bricks.....	43 gal.

For comparison, the following report shows the record of an Indiana manufacturer:

**Report No. 2.**

Type of kiln.....	Common up-draft
Number of bricks burnt.....	250,000
Type of burner.....	Inside mixer
Pressure of steam at burner.....	80 lb.
Pressure of oil at burner.....	30 lb.
Temperature of oil at burner.....	120 deg. F.
Time required .....	108 hours.
Total oil consumed.....	422 1/2 bbl.
Total oil consumed for 1,000 brick.....	71 gal.



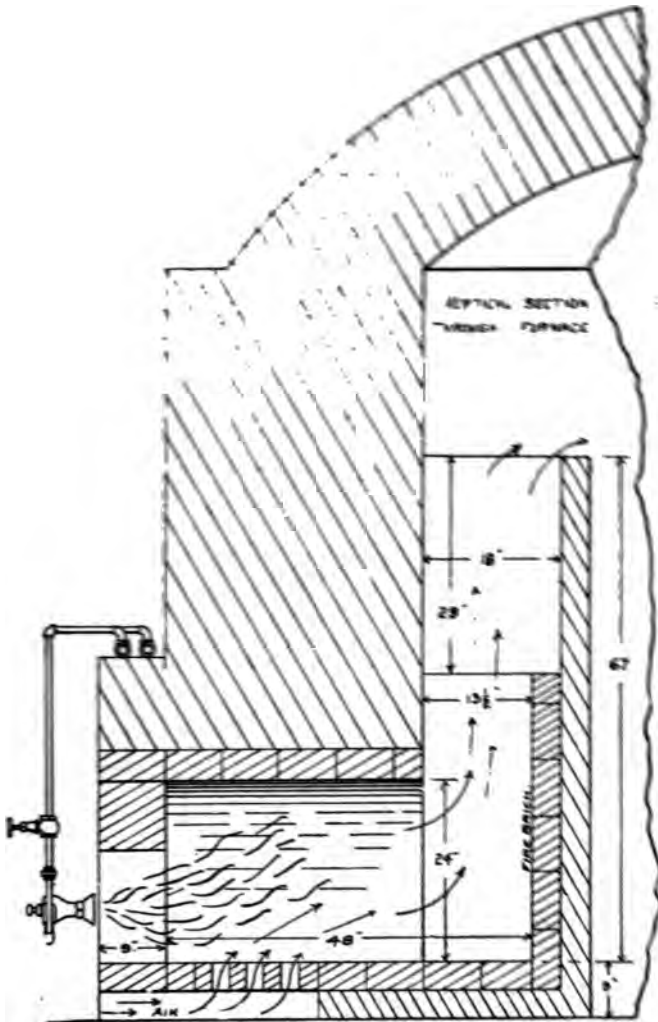

Fig. 49. Down-Draft Kiln.

A comparison of these reports shows the difference in oil consumption which may be expected with different kinds of clay.

As a rule, the down-draft kiln is more economical and is used almost entirely by manufacturers of crockery and sanitary ware. Fig. 49 shows such a kiln. It will be noted that a baffle wall extends upward in the

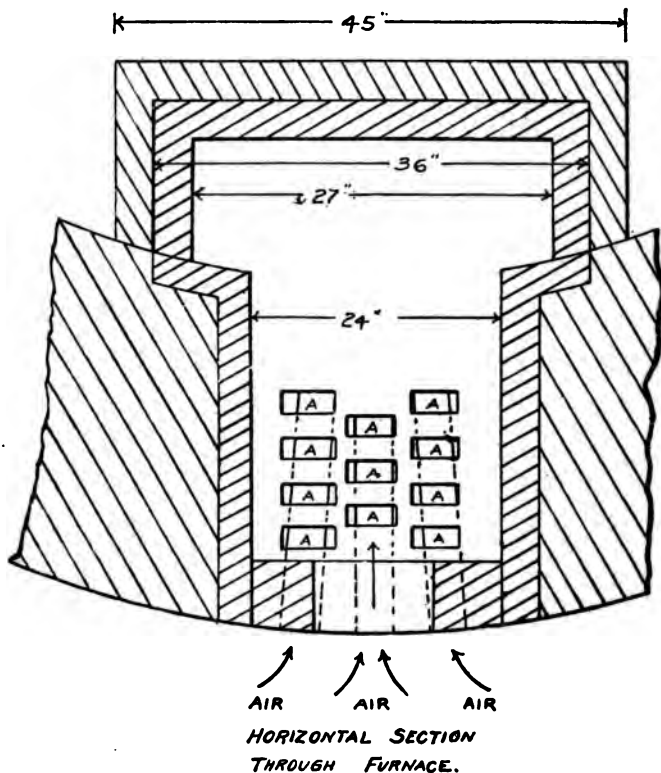

Fig. 50. Arrangement and Spacing of Brick.

kiln, thus preventing the flame from coming into contact with the ware. This is the most economical type of furnace construction. Particular attention must be paid to the arrangement and spacing of the brick, to allow proper admission of air for combustion, as shown in Fig. 50.

## OIL IN THE CLAY, LIME AND CEMENT INDUSTRY 67

Care should be taken in the selection of a suitable oil burner for this type of kiln. It should atomize the oil perfectly and give a short, flat flame, which spreads over the furnace and causes the air for combustion to come up and through the flame. To prevent the burning of the baffle wall the flame must not be long enough to strike it. Air is recommended for atomizing the oil in this type of kiln.

The following report was made by Johnson, Caswell Company, engineers of Los Angeles, Cal., on plant No. 1 of the Los Angeles Pressed Brick Company:

Report of kiln No. 21 of plant No. 1 of the Los Angeles Pressed Brick Company.

This kiln is 38 feet in diameter and 15 feet high from floor to highest point inside. It is equipped with 14 No. 1 burners suitable for down draft kilns.

The kiln was charged with 125,000 cream pressed brick, and the oil consumption was measured by a 2 in. Worthington meter.

Test started at 1:15 p. m., October 31, 1910.

Test completed 5:00 a. m., November 9, 1910.

Total time of test and heat, 106.5 hours.

Water smoking, 7 burners used 16 gallons of oil per hour.

Oil per burner per hour, water-smoking, 2.20 gal.

Oil per burner per hour, high heat, 7.10 gal.

Oil consumption, 14 burners, high heat, 100 gal. per hour.

Average oil consumption for entire heat, 52.6 gal. per hour.

Average oil consumption for entire heat, 3.76 gal. per hour, per burner.

Total oil consumed in entire heat, 10,349 gal. = 246.1 bbl.

Oil consumed per 1000 brick for entire heat, 827.9 gal.

Air used at high heat, 8 cu. ft. per burner per minute.

Temperature at high heat, 2426 deg. F. test cone 10.

The operation of the burners was perfectly satisfactory in every respect, and practically smokeless.

The muffle kiln illustrated in Fig. 51 is used by many manufacturers of enamel ware. In this kiln the product is surrounded with a wall that entirely protects it from the direct action of the flame. This type of kiln is necessary where the ware has to be treated with two or more coats of enamel, as the second and third coats must be applied when the ware is at a high temperature. A bathtub is a good ex-

ample of this process. The tub comes from the foundry and is cleaned and smoothed. Then a "filler" coat is applied. This is allowed to set a few days until thoroughly dried. Then it is swung into the furnace by means of a "fork," the temperature of the furnace being 1800 degrees F. As soon as it reaches a "heat," it is taken out and treated with powdered material, and

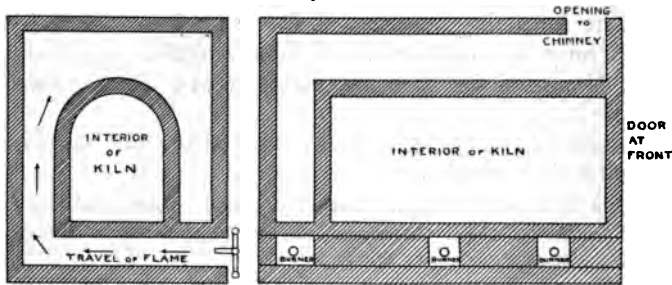

Fig. 51. Muffle Kiln.

replaced in the furnace until the operator knows that it is ready for the second treatment. The average time required to enamel a bath tub is 24 minutes. A typical muffle kiln has a capacity of 120 tubs each 24 hours, on a consumption of 10 bbl. of oil or  $3\frac{1}{2}$  gal. of oil per tub.

The burning of porcelain ware with fuel oil requires careful attention on the part of the fireman. The temperature must be regulated with precision. A common method of determining the temperature is by means of "cones," which are made from a composition of feldspar, kaolinite (china clay), quartz (flint) and calcium carbonate, so proportioned that the cones melt at definite temperatures. These "cones" are put into the "saggers" that are placed opposite small peep-holes, making it possible for the operator to regulate the temperature of the kiln.

The average size kiln is 17 ft. in diameter by 18 ft. high and is heated by means of ten furnaces located at equal centers around the bottom of the kiln. The total time necessary to burn the ware first is 56 hours,

the water smoking period requiring from 26 to 30 hours, followed by 22 to 26 hours of "high heat," a maximum of 2500 degrees F. being reached during this period. The kiln is then allowed to cool off gradually for a few days. This size kiln has an average capacity of 2500 lbs. of ware, and from 72 to 80 barrels of oil are used at one burning.

After the burning is completed the ware is dipped into an enameling solution, and allowed to air dry. It is then ready for the gloss kiln, which is of the same construction (See Fig. 52). The same method of placing the ware in saggars is used, as well as the "cones" for determining the temperature. Care must be taken with the temperature of the kiln during this process, as a sudden fall causes the ware to "blib," or show a wavy or lumpy appearance on the surface.

The total time required to complete the process of enameling is 36 hours. For 22 hours a "low heat" is required, followed by 14 hours of "high heat," a temperature of 2100 degrees F. being required during the "high heat" period. The oil consumption is about 60 barrels.

"Fire clay" is an indefinite term, applying in general to clays which do not fuse except at high temperatures. Although no definite limit has ever been set, it may be said that no clay can be called a fire clay of good grade unless it will withstand a temperature of 3000 degrees F. without sign of softening. When burned these clays are generally white or yellow in color. The value of fire clay can only be determined definitely by a refractory test.

The high fire resisting quality of a clay is due to the absence of fluxes, and to the fact that its composition approaches more or less closely to that of the ideal clay substance  $Al_2O_3 \cdot 2SiO_2 \cdot 2H_2O$ . A clay that contains much above 46.3 per cent silica, cannot, therefore, be a high grade fire clay. When purchasing fire brick the purpose for which it is to be used must be known, for it is impossible to obtain a fire brick which has great mechanical strength, and

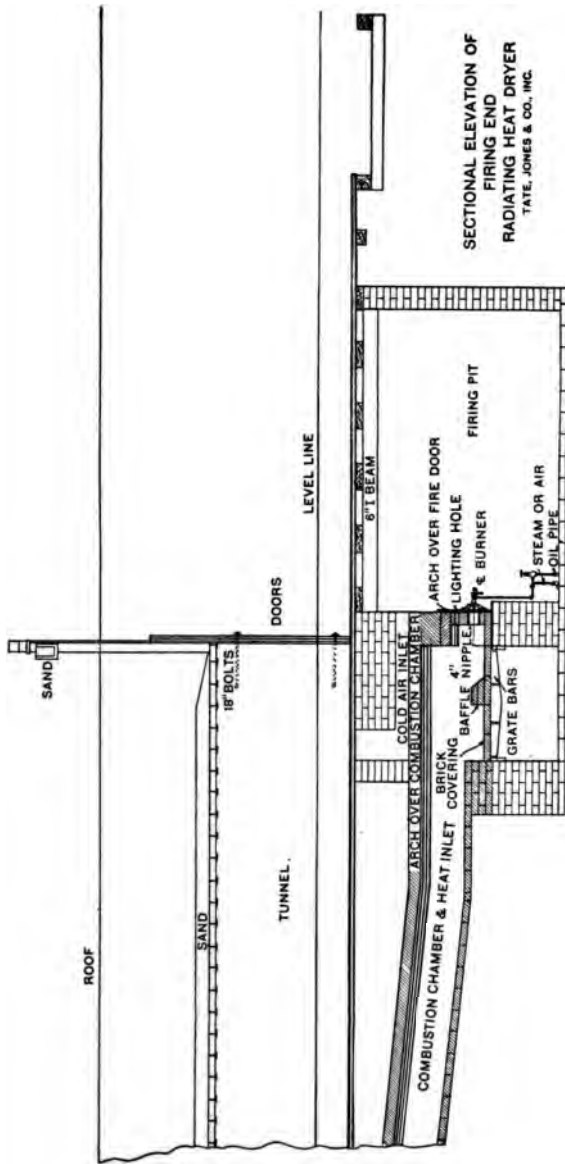

Fig. 52. Gloss Kiln.

**OIL IN THE CLAY, LIME AND CEMENT INDUSTRY 71**

at the same time is highly refractory. A fire brick which is coarse, clean, white and flinty, is of good quality, and highly refractory. If the grain is fine and smooth, the quality is apt to be poor.

When a boiler setting is required to stand an intense heat and carry a heavy load at the same time, it is well to construct the walls with two courses of fire brick. The inner course should be of highly refractory brick, and the outer course of strong brick. All fire brick should be dry when placed, and only a thin wash of fine clay used for a mortar. The bricks should be "tamped" until in contact with one another; for if a poor quality is used, or if the bricks are not tamped into place, they are likely to melt and run.

Common brick require from 35 to 50 gallons of crude oil per thousand bricks burned and about 5 days are necessary to water smoke and burn. The consumption of oil varies somewhat with the analysis of clay and percentage of water. The table below gives typical analyses of common brick clays:

**Chemical Analysis of Common Brick Clays.**

	Average. Per cent.	Minimum. Per cent.	Maximum Per cent.
Silica (SiO <sub>2</sub> ) combined.....	15.0	12.0	30.0
Silica sand .....	55.0	20.0	60.0
Alumina (Al <sub>2</sub> O <sub>3</sub> ) .....	14.0	11.0	25.0
Water (H <sub>2</sub> O), combined.....	4.0	3.0	9.0
Water moisture .....	2.0	0.0	6.0
Iron oxide (Fe <sub>2</sub> O <sub>3</sub> ) .....	4.0	2.5	8.0
Lime (CaO) .....	1.5	0.5	7.0
Magnesia (MgO) .....	1.5	0.3	7.0
Alkalies (K <sub>2</sub> O, Na <sub>2</sub> O) .....	3.5	2.0	7.0

In order to determine the length of time, the amount of fuel, and the air required for burning brick, one of the largest manufacturers of oil burning equipment has gathered the following data:

The oil for burning brick varies with different clays from 20 to 80 gallons per thousand brick—an average being 50 gallons per thousand. The burning of most clay wares can be divided into three periods, namely:

First—The drying out or water smoking period, requiring from 1 to 4 days of 24 hours each, with an average of

**2½ days.** During this period from 10 to 30 per cent of the gross amount of fuel required is burned, the average being 15 per cent.

**Second—**The period during which the temperature is raised from that of the water smoking period to the extreme temperature necessary to burn the ware, requiring from 2½ to 6½ days of 24 hours each, with an average of 4½ days. During this period from 45 to 75 per cent of the gross amount of fuel is required, the average being 65 per cent.

**Third—**The oxidization period, during which the maximum temperature is maintained, in order to thoroughly burn or vitrify the product. This varies from ½ to 2½ days, with an average of 1½ days, about 20 per cent of the gross amount of oil being burned.

The process of burning fire brick is similar to that of common brick, except that longer time, higher temperature, and much more oil is required. The average time being from 7 to 8 days, and the oil consumption per 1000 bricks varying from 120 to 140 gallons.

With oil burners only 8 cu. ft. of air or steam per lb. of oil is required for atomizing when the furnace shows a draught of ⅛ in. to ⅜ in. of water in a U glass. The amount of air required for atomizing is thus determined by the amount of oil burned during the second period, for during this period more oil is burned per burner per minute than during any other. Computations for a typical kiln are given below:

Assuming a kiln of 120,000 capacity:

**First Period:**

Total time—2½ days = 60 hours = 3600 minutes.

Total brick in kiln—120 M. divided between 10 burners, or 12 M. to each burner.

Total oil required per M. brick, 50 gallons.

During the 1st period, 15 per cent or 7.5 gal. = 56.25 lb. × 12 (M. brick) = 675 lb. of oil, divided by 3600 minutes = .1875 lb. per minute.

Air required for atomizing 8 cu. ft. per lb. of oil, or 8 × .1875, or 1.5 cu. ft. per minute × 10 burners or 15 cu. ft. per minute.



**Second Period:**

Total time— $4\frac{1}{2}$  days = 108 hours = 6480 minutes.

During the second period 65 per cent or 32.5 gal. =  $243.75 \times 12 = 2925$  lb., divided by 6480 = .451 lb. per minute.

Air required for atomizing 8 cu. ft. per lb. of oil or  $8 \times .451 = 3.40$  cu. ft. per minute  $\times 10$  burners, or 34 cu. ft. per minute.

**Third Period:**

Total time— $1\frac{1}{2}$  days or 36 hours = 2160 minutes.

During the third period 20 per cent or 10 gal. = 75 lbs.  $\times 12 = 900$  lb., divided by 6480 = .412 lb. per minute. Air required for atomization 8 cu. ft. per lb. of oil, or  $8 \times 4.12 = 32.96$  cu. ft. per minute.

Since the kiln selected above burned 120,000 bricks in  $7\frac{1}{2}$  days, or 16,000 bricks per day, the amount of air required for a similar kiln of any given capacity may be easily computed. Thus, for a kiln with a capacity of 30,000 bricks per day, a compressor capable of furnishing 65 cu. ft. of free air per minute is required. The most favorable working pressure for kilns is 20 lbs. per sq. in.

Lime is an oxide of calcium (CaO), and in one form or another is the basis of all mortars and cements. It is produced commercially by heating common limestone in specially constructed kilns. Fig. 50 shows a modern type of continuous oil burning lime kiln.

Limestone is calcium carbonate,  $\text{CaCO}_3$ . When heated to high temperature, it gives up carbon dioxide, which passes off as a gas, and oxide of calcium, or quicklime, remains. Carbon dioxide begins to come off at about 750 degrees F., but a temperature of over 1300 degrees F. is required to completely reduce the stone to calcium oxide. Commercial limestone nearly always contains considerable quantities of moisture and organic matter, which are driven off in the burning process. Clay, magnesia and iron oxide are other impurities often present, with the result that the actual yield of lime may vary from 55 per cent to 30 per cent or less of the stone.

Dense, compact stone is reduced with great difficulty, but the best quality of lime is produced

from such stone. The lime-kiln should be charged with lumps of stone uniform in size, about as large as a man's head. If the pieces are too large, or the temperature of the kiln too low, the lumps will not be calcined to the center, and the lime will not slake.

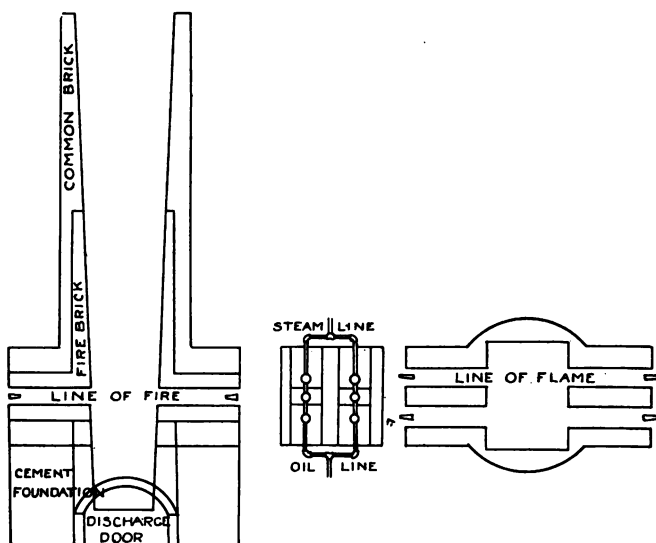

Fig. 53. Continuous Oil Burning Lime K'ln.

The diameter or width of the kiln when oil fuel is used, should not exceed eight feet at the burning zone; if it is greater than this the heat of the flame may not penetrate to the center of the rock. Care must be taken in arranging the burners and fire box. The chamber should be large enough to allow combustion to take place before the oil enters the kiln. This insures a soft, long, flame, permitting the gases to pass readily to the center of the kiln. If the burner is placed too far in, carbon is liable to form as a result of the flame impinging on the rocks. Furthermore, the lime near the flame is overburnt, while the lime in the center of the kiln is not burnt enough. The burner should be so constructed as to thoroughly

atomize the oil, and where possible a low pressure air burner should be used.

Air for combustion should be admitted around the burner, so that it will pass through the flame and thus insure complete combustion. Some lime kilns have

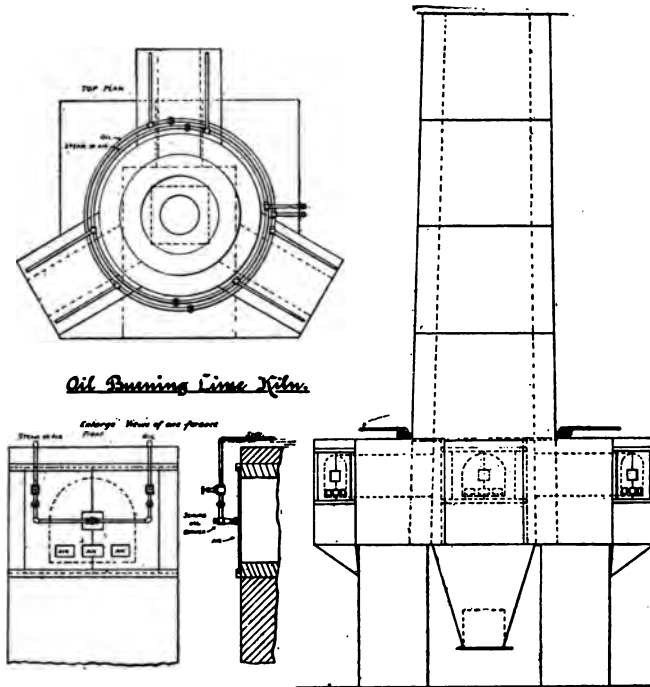

Fig. 54. Shurs Burners Applied to Lime Kilns.

been arranged to take the air for combustion from the stack by means of a steam siphon. Good results have been obtained by this method, as the flame is much softer and longer, and the volume of gases increased. These gases pass through to the center of the kiln, and when they carry a sufficient amount of carbon monoxide, secondary combustion takes place there.

Lime burning has been carried on in many types of kilns, most of which can be readily converted to the use of oil fuel. Oil burnt lime finds a ready mar-

ket because of its cleanliness. The continuous type of lime kiln has proven to be the most successful with oil fuel; the rotary kiln has also been used with good results; but in this kiln the stone is broken into small pieces with the result that the lime produced is not adaptable for building purposes. On the other hand, when lime has to be ground and hydrated, this type of kiln saves considerable power that would be consumed in grinding.

The following reports illustrate clearly the difference in the nature of the rock obtained from different localities.

**Report on Lime Kilns in Texas and Mexico.**

	Texas.	Mexico.
Total lime burnt in 24 hours....	40,000 lb.	30,856 lb.
Total oil consumed in 24 hours..	4,960 lb.	6,048 lb.
Barrels of lime (230 lb.).....	174 bbl.	129.8 bbl.
Barrels of oil.....	14.76 bbl.	18 bbl.
Gallons of oil per ton of lime....	31 gal.	54 gal.
Tons of lime per 24 hrs.....	20 tons	Metric tons, 14
Lime burnt per ton of coal as formerly used in gas producer	5	
Oil equivalent to one ton of coal	3.69 bbl.	
B.t.u. of oil.....	18,600	18,500
Oil pressure at burners.....	40 lb.	40 lb.
Steam pressure at burners.....	80 lb.	80 lb.
Temperature of oil at burners...	120° F.	110° F.

The term "cement," as used in building operations, signifies a compound of lime and other substances that hardens under water or in contact with water. It is a mixture of lime, or lime and magnesia, with clay, or silica, or both. It differs from common quicklime, in that it does not slake, expand or crumble, nor give off heat when wet, but chemically combines with part of the water to form a firm, solid rock.

Portland cement may be defined as a compound consisting chiefly of silicates and aluminates of lime, produced by the calcination to incipient vitrification of a mechanical mixture of calcareous and argillaceous materials. The clinker thus produced is subsequently ground to a powder. The exact chemical composition of Portland cement varies considerably, its principal constituents being lime, silica, aluminum, and

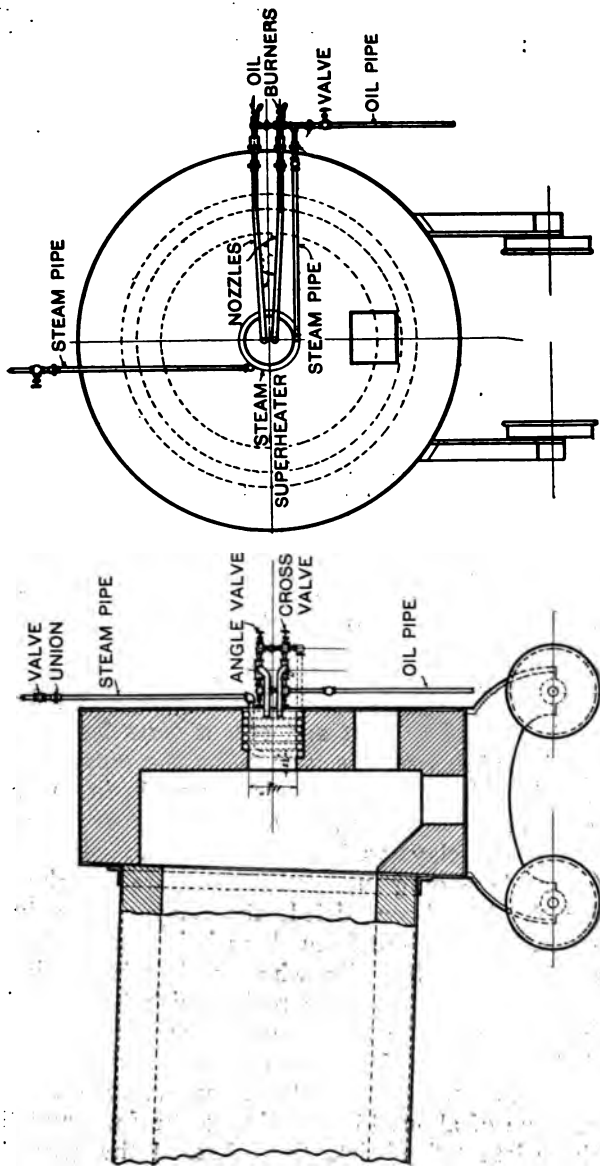

Fig. 55. Rotary Cement Kiln.

oxide of iron, mixed roughly in the following proportions: lime, 60 to 67 per cent; silica, 20 to 27 per cent; alumina 6 to 10 per cent; iron oxide 3 to 5 per cent. These four constituents, as a rule amount to about 96 per cent; the remainder consists of small quantities of sulphuric anhydride, magnesia, and alkalies.

There are two general methods of preparing and mixing the raw materials. One is known as the wet process, and the other as the dry or semi-wet process. The dry process is generally used because it is more economical. To illustrate this economy, the records of two factories, located within two miles of each other, are given in the following report:

	Dry Process.	Wet Process.
Duration of test.....	24 hours	24 hours
Type of burner used.....	Inside mixer	Inside mixer
Atomizing agent.....	Steam	High pressure air
Pressure of agent at burner	90 pounds	80 pounds
Pressure of oil at burner..	40 pounds	60 pounds
Temp. of oil at burner....	110° F.	100° F.
Cement in metric tons.....	48 tons	31 tons
Equiv. in bbl. of 380 lb....	240 bbl.	180 bbl.
Oil used per ton.....	58 gals.	70 gals.
Equivalent oil used per bbl.	10 gals.	12 gals.

A rotary kiln is used almost exclusively in the manufacture of cement and recent tests have proven large, long kilns of this type to be the most efficient. (See Fig. 55.) The clay is treated in a small rotary kiln or dryer. The oil required to dry one ton of clay varies from five to six gallons per ton, depending upon the moisture of the clay. After having been dried, the clay is ready for the powder mill, and from there it is conveyed to the top of the roasting kiln, where it is mixed with the necessary amount of lime rock, which has also been reduced to a powder. The main rotary kilns are steel cylinders varying from 6 to 10 ft. in diameter and from 60 to 100 ft. in length. They are set on rollers, at a slope of about  $\frac{1}{2}$  to  $\frac{3}{4}$  in. to the foot, and lined with resistant fire-brick, to withstand the great heat to which the inner surface is subjected. When operating, the cylinder slowly revolves upon the roller by

means of a train of gears; this motion, in connection with the inclination of the cylinder, causes the cement mixture, which is fed into the kiln at the upper end, to move slowly to the lower end of the cylinder where it discharges into a clinker pit. As the raw material slowly works down into the interior of the kiln, the heat generated from the burners first drives off the water and the carbon dioxide from the mixture and then causes the lime, silica, alumina, and iron to combine chemically and form a partially fused mixture known as "cement clinker." The operation during this period is closely watched by the operator. The rate of feeding the raw material is regulated by the speed which the cylinder revolves. The temperature of the kiln is regulated by the appearance of the clinker.

The physical and chemical changes which occur within the kiln are divided into two stages. During the first, the water and carbon dioxide is driven off, the temperature of the kiln averaging about 1800 degrees F. During the second stage a temperature of 2800 degrees F. is maintained, and the burnt mass is thoroughly fused. The greatest care must be exercised by the operator during this period, for if the clinker is burned too much or too little, the value of the cement will be greatly reduced. After fusion is complete, the clinker is cooled and passed to the ball and tube mills where it is ground into a fine powder.

Different cement manufacturers have widely different views on the method of firing kilns. Some recommend an intense, concentrated heat as the clinkering or fusing point, claiming that the calcining is effectively carried out by the lower temperatures of the spent gases. Others require a long, sweeping flame, extending back many feet into the kiln, claiming that they get a much more perfectly burnt clinker by this method. It is possible that peculiar characteristics of the raw materials make the latter method desirable in some cases; but in the opinion of the writer, much more economical results can be obtained by the first method.

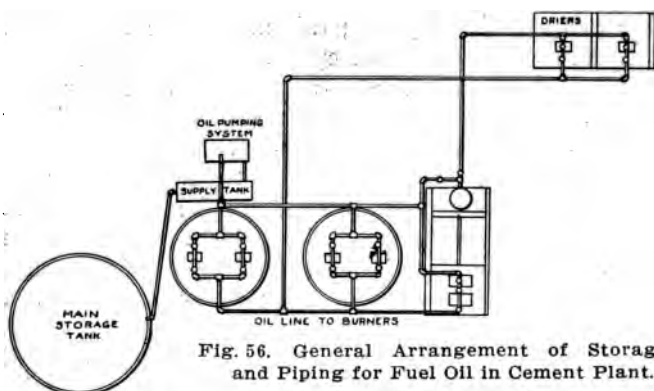

Fig. 56. General Arrangement of Storage and Piping for Fuel Oil in Cement Plant.

Some manufacturers claim to be able to make cement with from  $8\frac{1}{2}$  to  $9\frac{1}{2}$  gal. of oil per bbl. of cement. It is difficult to verify these statements, as the utmost secrecy is maintained in all details of operation. Frequently, however, errors can be found in their method of calculating the exact amount of oil used. Some take measurements from faulty meter readings, while others do not allow for the amount of oil required to produce the atomizing agent. A careful reading of the report reproduced below will show that the average amount of oil required per bbl. of cement lies between 10 and 12 gallons.

Various types of burners are used in cement kilns. Some use the steam atomizing type, some the high pressure air type, and some the low pressure air type. The last type has proven so much more economical than the others that many plants throughout the country have converted from steam or high pressure air burners to low pressure burners. Fig. 56 shows a complete fuel oil installation at a cement plant.

**Report From Portland Cement Plant in California.**

Duration of test .....	24 hours
Type of burner used.....	Steam
Pressure of steam at burner.....	80 lb.
Pressure of oil at burner.....	45 lb.
Temperature of oil at burner.....	110° F.
Estimated weight of clinker burnt.....	71.060 lb.
Estimated bbl. of cement.....	187 bbl.
Barrels of oil consumed at kiln.....	40.98 bbl.
Gallons of oil used in dryer.....	67.8 gal.
Oil used to furnish steam for atomizer.....	90 gal.
Total oil used per bbl. of cement.....	10 gal.



---

## CHAPTER VII.

### OIL AND THE GLASS INDUSTRY.

In order to make clear the application of fuel oil to the glass industry, a general description of the process of making glass will be given. Broadly speaking, glass is made by properly melting together, cooling, and shaping, certain raw materials, of which silicates play the most important part. At the outset, the finely ground raw materials are thoroughly mixed, sometimes by regrinding the entire "batch." The "batch" is then shovelled into a pot together with a certain amount of broken glass called "cullet," which melts at a comparatively low temperature, and thus assists in liquefying the rest of the charge. More of the batch is added until the pot is filled to the desired height with the fused mass, then volatile substances, such as arsenious acid, used to decolorize the glass, are added. During the melting much gas ( $\text{CO}_2$ ,  $\text{SO}_2$  and  $\text{O}$ ) escapes, and the bubbles rise through the melt, stirring it and causing frothing. A considerable amount of alkali and other constituents volatilize.

When the melt has come to a state of quiet fusion the temperature is generally raised somewhat, and the liquid glass allowed to stand for a time. This is called "refining," and its object is to form a homogeneous mass, free from bubbles and bits of uncombined silica or other matter. The scum which collects is skimmed off; it is called "glass gall," and consists of undecomposed sulphates and chlorides of lime and alkali, alumina compounds from the furnace, and various other impurities. If too little carbon is used in

the batch, the melt is covered with a layer of fused sodium sulphate; this is known to the workman as "salt water." Samples of the glass are examined during the refining, to determine the exact time of heating. After refining, the glass is too liquid to blow, or to work to advantage, and is cooled until it becomes pasty.

Glass is known under various names in commerce, depending to the method of its manufacture or the uses to which it is put.

**Plate glass** is cast on a large iron plate or "casting table," made of thick narrow segments of cast iron, bolted together and planed on top. These tables were formerly cast in one piece, and, being large and thick were very expensive. But when used, they soon became warped and dished, owing to unequal expansion of the top and bottom. This caused much loss of time and glass in the subsequent grinding of the plate. The built-up casting table is much cheaper and retains its even surface much longer. The melted glass is poured on the table and spreads out in an even layer. But to give the plate a uniform thickness, and to smooth down any inequalities of the surface, a heavy iron roller, traveling on adjustable guides at the edge of the table, is passed over it. The height of these guides determines the thickness of the plate. Both the casting table and the roller are heated before use, so that the glass may not be cooled too rapidly. As soon as the plate is rolled it is transferred to the floor of the annealing furnace, which has been heated to the temperature of the glass, and which is directly in front of the casting table. The annealing oven is then closed tightly and the fire drawn, leaving the plate to cool slowly for a number of days.

All glass must be annealed. This process probably allows the molecules to arrange themselves so that there is no great internal stress when the mass is cooled. Unannealed glass, which has been suddenly cooled, is always under high internal strain which

makes it exceedingly brittle, and may even cause it to fly to pieces spontaneously, or when slightly scratched.

When removed from the annealing furnace, the plate is uneven and rough and may be somewhat devitrified on the surface. It is fastened on a horizontal table, and heavy cast iron rollers are made to slide over its surface with a rotary motion, while coarse sand and water are sprinkled on it. When the glass is smoothed off and of a uniform thickness, it is polished by rubbing with buffers, covered with leather or felt, and used with fine emery dust or putty powder. About one-half of the thickness of the plate is cut away during the grinding and polishing.

Plate glass is usually a soda-lime glass. The batch is melted and refined as described above, great care being taken to remove all the "gall," which is skimmed off immediately before the casting. An especially strong pot is used, which will stand the strain of lifting from the furnace while full of melted glass. The furnace is constructed with brick-lined, cast iron doors, which open to permit the removal of the glass. The melting and annealing furnaces are often joined, so that the latter may be heated with waste heat. Sometimes several plates are annealed at one time.

The chief uses of plate glass are for windows and mirrors. A considerable quantity of rough plate, unground as it comes from the annealing furnace, is used for flooring and sky-lights.

**Window glass** is always blown. It is usually a soda-lime glass, and the batch is melted and refined in the usual manner, either in pots or in tanks. After refining, the glass is allowed to become pasty and then the blower begins his work. His chief tool is the "pipe," a straight piece of iron tubing four or five feet long, usually provided with a mouthpiece. He dips the pipe into the soft glass, which is called "metal," and gathers a lump on the end. Then, by blowing through the pipe, while whirling it between the palms of his hands he forms a hollow globe of glass. This is re-heated in a special furnace called a "Glory-hole,"

(Fig. 57), until soft, rolled on a flat surface, and then swung in a vertical circle, with occasional blowing through the pipe until the globe has elongated into a hollow cylinder, closed at one end and opening into the pipe at the other. In order to have plenty of room



Fig. 57. Kirkwood Burners in "Glory Hole" at Heinz Bottle Works.

for the vertical swinging, the workman stands on a plank or bridge placed across a rather deep pit. The closed end of the cylinder is reheated until soft, and then blown out; the small opening thus made is enlarged by means of the widening tongs. The pipe is detached by touching its point of attachment with a wet stick, and the edges of the still soft glass are trimmed with shears. A hollow cylinder open at both ends is thus formed, and is cut lengthwise with a diamond. It is then put into the flattening furnace, in such a position that the cut is on the upper side. The heat being sufficient to soften the glass, the cylinder slowly opens and spreads out on the floor

of the furnace in a flat sheet. It is then transferred to the annealing furnace for blown ware (Fig. 58). This consists of a long oven, heated at one end and cool at the other. A system of endless iron bands carries the glass from the hot to the cool end of the oven. Sometimes the glass tube to be annealed is placed on a large horizontal table, usually built of slabs of stone, and carefully balanced so as to revolve easily and slowly by means of a gear, while the seg-

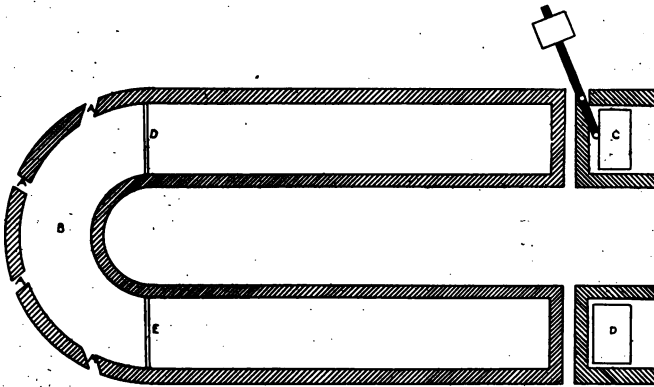

Fig 58. Annealing Furnace for Blown Ware.

ment passes through a narrow opening in the side of the flattening furnace, where it is exposed to the high temperature. The glass is thus slowly carried out of the furnace into a cooler compartment from which it is removed when nearly cold. The table is chiefly used for window glass.

The glass sheets are now cut into marketable size without any polishing. Since the surface of blown glass is fused and not polished, it is brilliant and hard. Consequently it is less easily scratched or etched and is more durable than plate glass when exposed to the weather.

Glass blowing is an exceedingly fatiguing labor, and only men of strong constitution and good lungs can do it. The mass of glass which a good workman will handle at one time, averages about 18 pounds, and

from it he will form a cylinder over a yard long and a foot in diameter.

**Pressed glass** is made by the use of a die or mould; these moulds are quite expensive, but owing to the great number of pieces of the same form and design that are made with slight labor, pressed ware is fairly cheap.

**"Tough"** or **"tempered"** glass is produced by a special method of annealing, the articles so treated being capable of withstanding blows and sudden changes of temperature. This tempering is done by plunging the article, while still so hot as to be somewhat soft, into a bath of oil heated to 100 deg, to 300 deg. C. This sudden "quenching" hardens the surface of the glass but causes internal stresses. If scratched or cut slightly, toughened glass is very apt to fly to pieces, sometimes with great violence. And even after standing a long time, spontaneous fractures often occur. It is mainly used for lamp chimneys.

A process for making hardened glass plates and window lights is employed in which cold metallic surfaces are applied to the glass plates while the latter are still plastic. The sudden chilling imparts an exceedingly hard surface to the glass, so that it can be used in exposed situations, as in street lamps.

Glass making may seem simple, but great skill is required on the part of the workman. This is especially true in the manufacture of bottles by the old method described above. There are bottling machines which are entirely automatic, the siphoning of the molten glass being accomplished by means of a vacuum, the molding by an automatic process, and the blowing by compressed air. Only one operator is required and he merely removes the bottles as they are made.

A glass factory using oil as a fuel will now be described. The glass furnace as shown in Fig. 57 is called the regenerative type of furnace; in it, the air for combustion passes up through one flue to the combustion chamber, through the furnaces, and down through the other flue. Thus the inlet chamber, which

is made of checker-work brick, imparts its heat to the incoming air, while the escaping gases are heating the checker-work brick in the other chamber. The air is reversed at intervals of twenty minutes. Thus the air required for combustion is always well heated. The oil is fed by means of a pumping system installed by

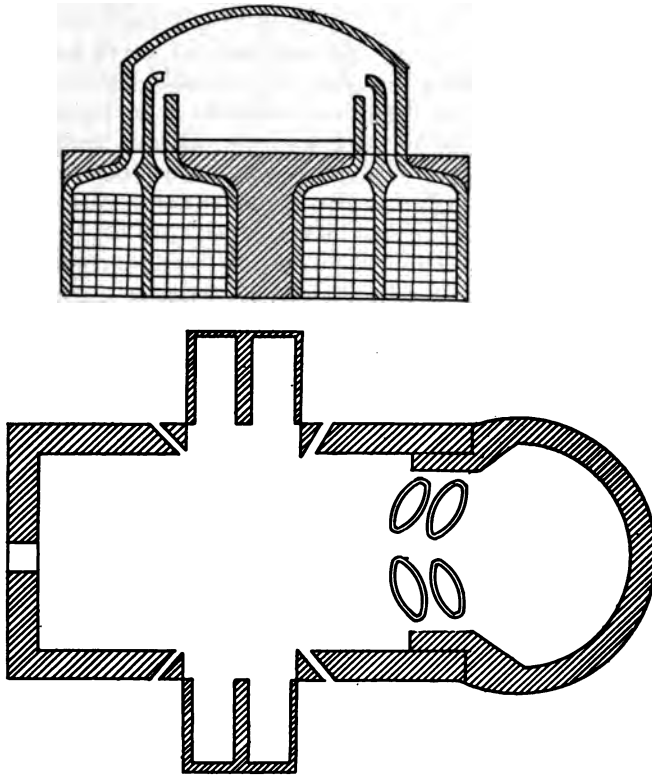

Fig. 59. Regenerative Type of Glass Furnace.

the Tate-Jones Company. The oil burners were designed by the same company, and use compressed air at 40 lb. pressure to atomize the oil, which is supplied at a temperature of 140 deg. F. and a pressure of 40 lb.

Three weeks are required to bring the furnace illustrated up to its proper working temperature, in order to prevent cracking of the walls as a result of uneven expansion. The finely ground raw materials, together with some broken glass are then introduced until the capacity of the furnace is reached. When the "batch" reaches its "fusion" point, 2500 deg. F., the temperature of the furnace is raised to 2700 deg. F.

"Floaters" of fine clay are held in place by the current of melted glass flowing towards the revolving tank. The liquid passes under the floaters, which skim off the impurities that have arisen from the "batch" during the melting and refining process. This leaves the glass in the revolving tank with a clean surface, free from bubbles. The temperature of the revolving tank is much lower than that of the main tank.

The molten glass is taken by the "bottle machine," and made into bottles. The bottles are then passed through the annealing furnace, Fig. 58. They enter at the door C, and by means of an endless chain gear are carried to D where they pass to a revolving table and are conveyed through B. This is the hottest part of the furnace, usually heated to 1200 deg. F. It will be observed that the bottles come into direct contact with the flame at this point, and when removed are quite clean, excepting for a cloudy film. It was first thought that this film was caused by poor atomization of the oil. The chemist made some observations and stated that it was not an oil soot, but some unknown composition possibly due to the vaporization of the water in the oil. This film is readily removed by wiping with a damp piece of cloth. At E the bottles are again passed to the endless chain gear and pass out the door F. This operation requires about 36 hours. The bottles are then examined, cleaned, and packed for shipment.

It is estimated that about six tons of bottle glass are melted and refined in this furnace with an oil consumption of 840 gallons barrels, or 140 gallons of oil



per ton of glass. Blown window glass may also be made in this style of furnace.

The common pot furnace is used by some of the smaller manufacturers. It is similar in construction as the crucible steel furnace shown in another part of this book. A small special furnace called the "glory hole" is also used in many factories for the purpose described in making window glass. There are also small square furnaces about 18 in. x 18 in. x 24 in., inside dimensions. The flame passes down through the top to a combustion chamber, and the heat of the flame passes over into the furnace. Such a furnace is kept at a low white heat. In some glass factories, small furnaces are used to dry the sand and to prepare the limestone. Air is almost universally used for atomizing the oil.

Many large glass factories are now using fuel oil because of its cleanliness, in spite of the fact that it costs more than other fuels. The flame comes in direct contact with the glass without producing any discolorization or deterioration and the temperature may be maintained absolutely uniform, thus saving many articles formerly ruined by the fluctuations in temperature caused by unsteady firing.

## CHAPTER VIII.

### OIL BURNING LOCOMOTIVES.

The first successful operation of oil burning locomotives was on the Griazi-Tsaritzin Railway, in Russia. Thomas Urquhart, who was superintendent of motive power, converted some of the coal-burning locomotives to oil burners in 1882. Several reports have been published showing comparisons between the performances of these locomotives before and after this change was made. The calorific value of the oil was 18,600 B.t.u., and the coal used was Russian anthracite, very similar to Cardiff coal, having 14,000 B.t.u. One pound of oil was found to be equivalent to 1.78 lb. of coal.

In a discussion before the Institute of Mechanical Engineers in 1899, Mr. Urquhart stated that the highest actual evaporation obtained was 14 lb. of water per lb. of oil, at 125 lb. steam pressure, from 60 deg. This would be equivalent to 16.8 lb. from and at 212 deg. The average evaporation was 12.5 lb. of water per lb. of oil. These fine results were obtained in spite of a handicap imposed by the Russian government, which would not allow the railway company to adopt fuel oil unless they proved that the fire-box could be changed at a moment's notice to burn coal.

As a comparison between the two fuels, the following report is given. This should be compared with the reports from other railways given elsewhere:

**Consumption of Coal in 1882 and Petroleum Residuum in 1885  
Inclusive of Kindling Wood, or Two Types of  
Engines on Griasi-Tsaritsin Railway.**

**Eight-Wheeled Engines—With Coal in 1882.**

Month.	Average No. in train.	Aggregate distance of		Aggregate distance run by freight cars. miles.	Petro- leum residu- um. lbs.
		Aggregate distance run by loco- motives. miles.	unpro- ductive run of loco- motives. miles.		
January ...	33.82	41,296	7,003	1,294,696	98.33
February ..	34.21	37,444	5,770	1,082,924	86.91
March .....	33.41	20,881	1,956	632,410	87.44
April .....	38.14	24,293	3,329	850,147	73.01
May .....	41.24	31,145	4,757	1,170,956	70.62
June .....	40.53	37,520	4,907	1,321,835	73.04
July .....	43.64	29,749	5,802	1,045,201	71.74
August ....	39.99	38,751	6,028	1,308,734	71.28
September..	39.54	56,586	9,298	1,866,171	76.26
October ....	35.13	71,041	11,891	2,981,474	77.06
November ..	36.56	70,466	12,648	2,114,172	92.54
December ..	34.00	52,763	7,166	1,416,010	99.82
<b>Total and av. for 1 year.</b>	<b>37.51</b>	<b>511,935</b>	<b>80,555</b>	<b>16,184,730</b>	<b>81.43</b>

**With Petroleum Residuum In 1885.**

Month.	Average No. in train.	Aggregate distance of		Aggregate distance run by freight cars. miles.	Petro- leum residu- um. lbs.
		Aggregate distance run by loco- motives. miles.	unpro- ductive run of loco- motives. miles.		
January ...	37.72	83,636	16,066	2,549,230	48.30
February ..	37.15	55,222	10,449	1,663,813	49.98
March .....	30.95	38,742	3,247	1,405,162	52.79
April .....	41.03	60,477	9,809	2,079,544	42.68
May .....	40.81	87,805	13,489	3,033,003	41.00
June .....	41.68	75,175	11,029	2,673,988	41.84
July .....	38.80	63,901	8,160	2,120,526	38.19
August ....	40.32	74,272	10,796	2,560,034	41.50
September..	39.76	82,415	13,241	2,654,637	41.22
October ...	37.61	101,253	15,468	3,226,698	47.74
November ..	36.24	82,346	16,434	2,388,761	42.95
December ..	34.85	63,468	9,482	1,881,136	54.19
<b>Total and av. for year..</b>	<b>38.08</b>	<b>868,712</b>	<b>137,670</b>	<b>28,565,555</b>	<b>45.83</b>

## INDUSTRIAL USES OF FUEL OIL

With Six-Wheeled Engines—With Coal in 1882.

Month.	Average No. in train.	Aggregate distance of			Petroleum residuum.
		Aggregate distance run by locomotives. miles.	unproductive run of locomotives. miles.	Aggregate distance run by freight cars. miles.	
January ...	21.32	78,244	36,032	897,826	62.60
February ..	27.47	43,160	23,008	560,152	55.15
March .....	26.52	27,742	15,337	329,249	52.73
April .....	28.59	57,514	22,497	1,004,129	53.84
May .....	31.90	111,181	40,974	2,241,273	56.58
June .....	30.74	147,720	48,638	3,043,384	57.46
July .....	28.39	145,232	51,826	2,652,482	48.69
August ....	27.04	152,659	52,697	2,703,475	49.88
September..	28.93	143,000	50,112	2,693,239	55.49
October ...	23.30	163,442	53,837	3,101,778	62.29
November ..	21.60	159,669	43,640	2,508,388	63.88
December ..	20.04	112,118	36,081	1,517,773	68.37
Total and av. for year..	26.32	1,341,681	474,679	23,253,148	57.25

With Petroleum Residuum in 1885.

Month.	Average No. in train.	Aggregate distance of			Petroleum residuum.
		Aggregate distance run by locomotives. miles.	unproductive run of locomotives. miles.	Aggregate distance run by freight cars. miles.	
January ...	22.14	114,192	46,052	1,509,005	34.43
February ..	22.01	89,648	37,513	1,148,056	34.09
March .....	22.58	88,950	33,721	1,097,442	28.98
April .....	25.33	141,584	46,654	2,354,348	31.78
May .....	28.49	179,872	65,985	3,246,003	29.88
June .....	28.35	144,669	55,347	2,533,104	29.93
July .....	24.77	131,341	48,001	2,064,742	27.57
August ....	28.27	128,559	46,677	2,315,544	28.75
September..	31.89	130,846	46,088	2,703,087	32.07
October ....	28.04	125,523	38,266	2,448,912	35.55
November ..	21.41	119,788	36,258	2,451,573	35.74
December ..	22.15	92,361	34,171	1,287,893	38.18
Total and av. for 1 year.	25.45	1,487,333	534,733	25,159,709	32.23

To illustrate the great improvements in the design of oil-burning locomotives made in recent years, it will be interesting (for comparison), to examine some of the earlier models. Fig. 60 shows the details of arch, ash-pan, and position of burner and brick work as used by the Santa Fe Railroad. When first

Changing from coal to oil, it was necessary to remove the grates and bearing bar, and to fit a pan below, riveted to the sides. This pan acted as a bearing for the necessary brickwork, and was arranged to allow the air for combustion to pass through the

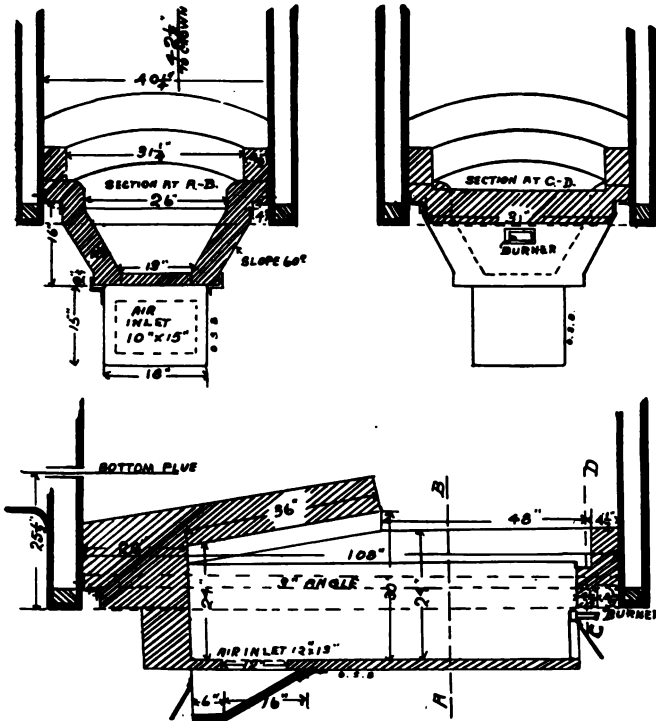
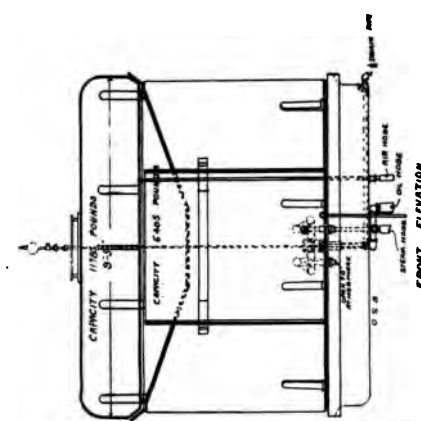

Fig. 60. Arch and Ash Pan Arrangement on Old Santa Fe Oil Burning Locomotive.

brick work. The fire-box arch was built in front of the flues, thus protecting them from the flame. The burner was placed at an angle, to allow the flame to strike below the arch.

The regular coal and water tenders were used by placing a specially constructed oil tank into the coal compartment. A large rectangular tank with a combined capacity of over eight tons of oil, was placed



FRONT ELEVATION

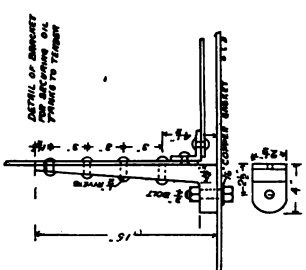

DETAIL OF HOSE CONNECTOR FOR RECEIVING OIL FROM TO THERM

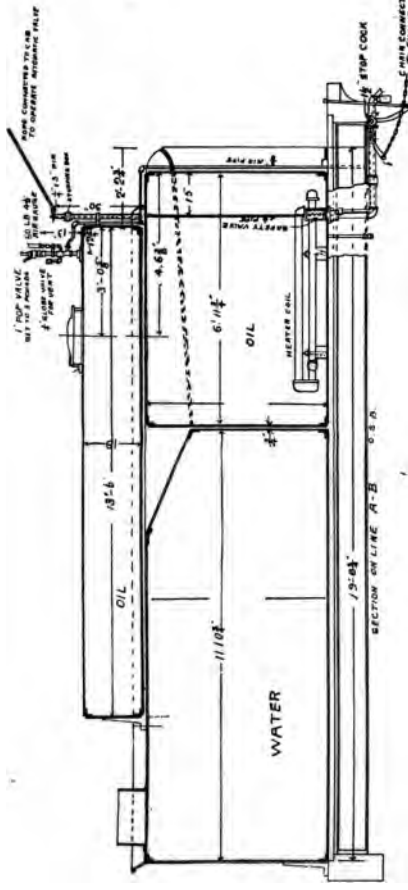

SECTION ON LINE A-B

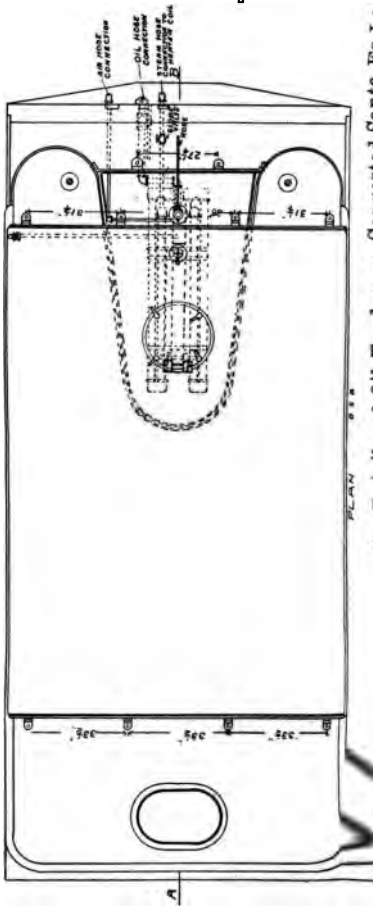

PLAN

U. S. PATENT OFFICE

over the top, securely anchored to the tank frame. The oil was heated by means of a heater coil. This was necessary because of the low gravity of oil used at times.

Fig. 61 shows the details of these early converted tenders as used on the Santa Fe railroad. The cost of converting these old locomotives and tenders averaged about \$350 each.

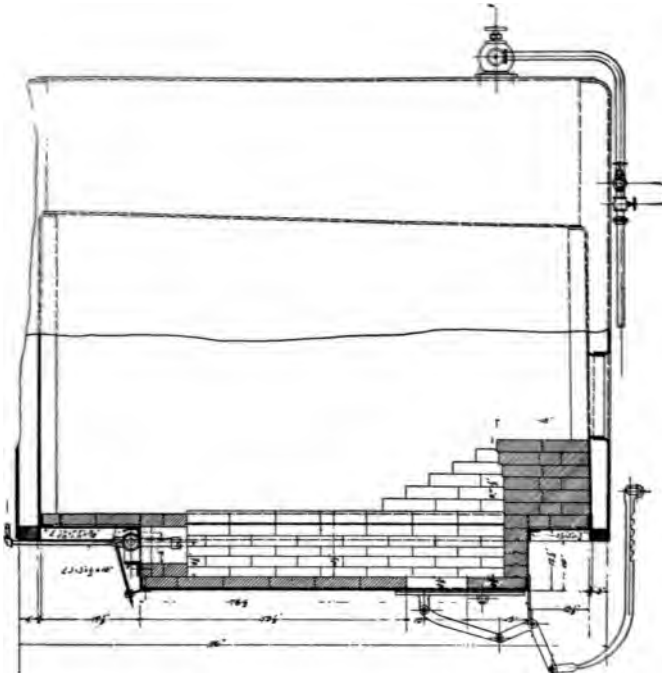

Fig. 62. Details of Modern Oil Burning Locomotive Fire Box.

The improvements of recent years have abolished the arch setting, as shown in Fig. 62; this also eliminates the combustion chamber. The burner is reversed, and placed at the front end of the fire-box, which is lined with fire-brick about  $2\frac{1}{2}$  in. thick on all sides except the back, where the wall is 18 in. thick. The air for combustion enters at the bottom,

and the admission is regulated by means of a damper. It is led under a layer of fire-brick to the burner, being heated by coming in contact with the hot brick. The natural sweep of the gases carries them to the back end of the fire-box, where they strike the heavy fire-brick wall and turn back and up through the

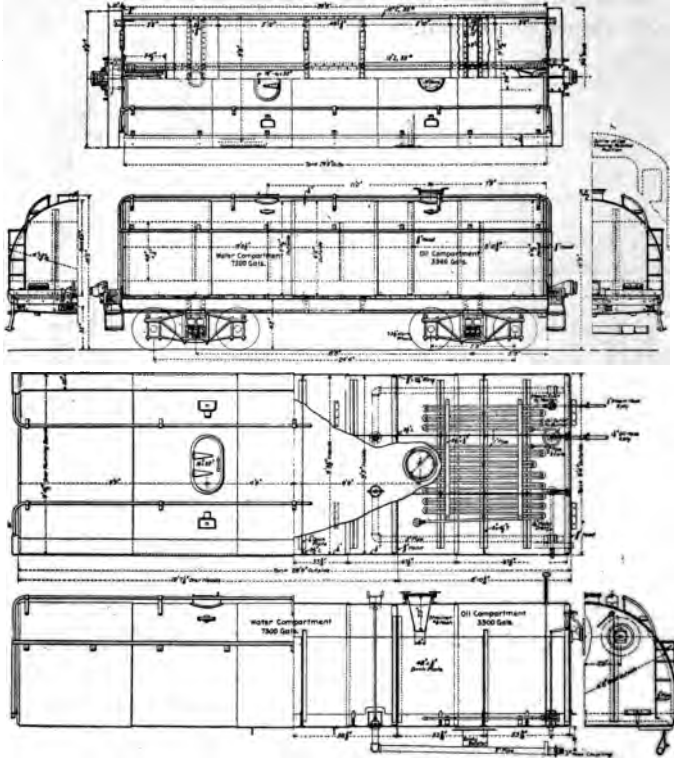

Fig. 63. Semi-cylindrical Tender Used by Southern Pacific Company.

flues. The cost of maintenance is considerably lowered by this arrangement, as the flame does not strike on the tube sheet and the expense of rebuilding the arch is eliminated.

Fig. 63 illustrates in detail the semi-cylindrical tender and tank for oil burning locomotives used by



the Southern Pacific Company. The tank is divided into oil and water compartments, the former of 3300 gallons, the latter of 7300 gallons capacity. The length outside is 28 ft. 6 in., width 9 ft. 4 in., height 6 ft. 5 in., these being measurements on the tank proper. The radius of curvature of the top is 4 ft. 8 in.; the lower part of the sides are straight. The tank is constructed of  $\frac{1}{4}$  in. steel, with lap seams, single riveted with  $\frac{5}{8}$  in. rivets at 2 in. pitch. Manhole rings, and the plate for the oil compartment, are of cast iron, with openings 16 in. in diameter. The cover is slightly convex in form, and is held in place by three bolts having hand-wheel heads for easy removal. The opening is provided with a six mesh strainer, 22 in. deep, and tapering to 6 in. at the bottom. The interior of the compartment is provided with lateral and intersecting splash plates, and with a steam coil of 1 in. pipe on the bottom. A small coil of  $\frac{1}{2}$  in. pipe, in series with the larger coil, surrounds the oil outlet, in order that these tanks may handle the heavy oil of Kern county. The outlet valve which discharges into a  $1\frac{1}{4}$  in. pipe, is controlled by a vertical lift rod attached to a bell crank, the latter being connected to another bell crank on the outside of the front head. It is customary to connect the outside bell crank with some point in the cab by means of a string, so that in case of a break-in-two between engine and tender, the jerk on the string, in conjunction with the spiral spring above the valve, will operate to close the latter. The vertical rod just beside the valve rod, and extending through the top of the tank, is a measuring stick. The water compartment has the usual equipment of splash plates and outlet valves, the latter being surrounded by copper strainers, and discharging into 3 in. pipes leading beneath the floor to the front of the tender.

Some of these improvements and figures shown are taken from data secured in Mexico. Oil has been adopted as a fuel there within the last few years. The arrangements shown are the results of careful investi-

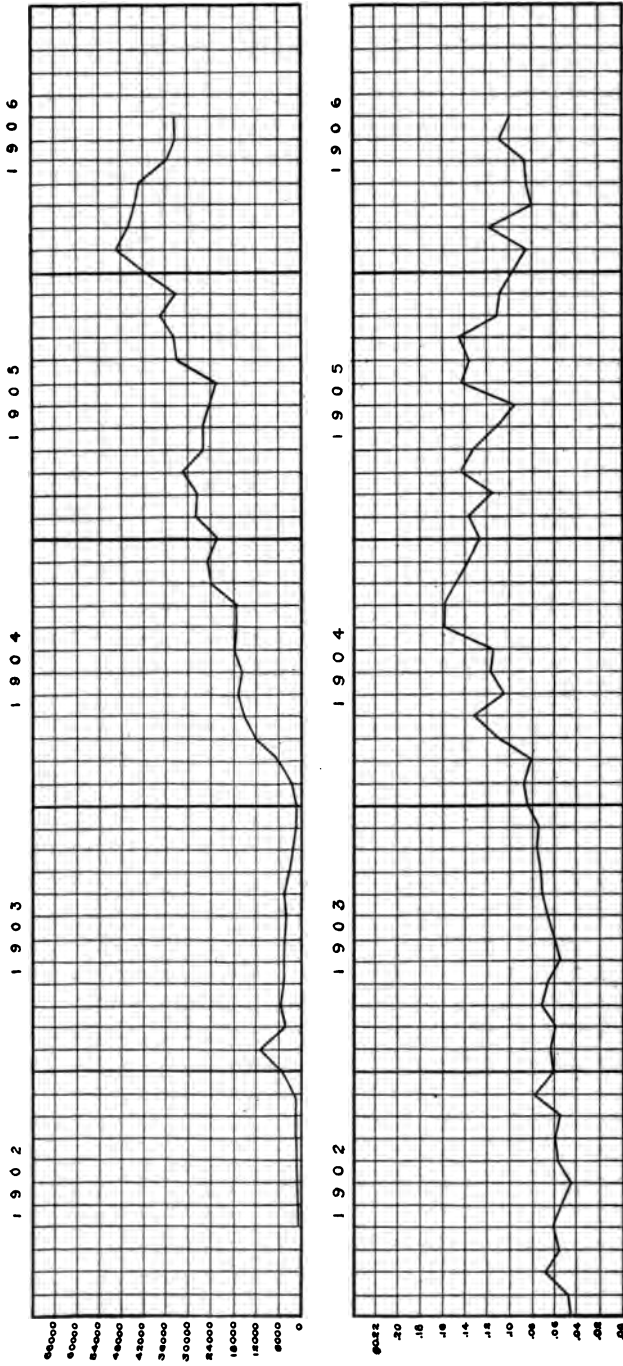

Fig. 69. Upper Chart Shows Cost per Mile for Locomotive Repairs, Lower Shows Oil Consumption.

gations by the engineers, after a thorough study of the most successful oil burning locomotives in the United States and Europe. They are very similar to the ones used today by the leading railways in the United States now using fuel oil. The average cost of changing locomotives to oil in Mexico is about \$500 gold.

To show typical operating conditions on railroads at present burning oil, the author has gathered the data presented in the remainder of this section. Fig. 65 shows an interesting chart prepared by a railway company giving the cost per mile for locomotive repairs, and the consumption of oil during the same period.

The front end design of locomotive has an important bearing on their economical operation, as the forward chamber is in reality a vacuum pump, which draws the gases and air from the fire-box and tubes and discharges them through the stack. The vacuum created depends upon the size and shape of the nozzle used. The tests recorded below indicate the great difference in efficiency which is secured with different nozzles.

Nozzle.	Draft	Evaporation per hour
Round .....	10.2 inches	43,702 lbs.
Rectangular .....	14.6 inches	49,284 lbs.
Elliptical .....	19.6 inches	58,882 lbs.

The size and length of the tubes also affects the amount of fuel consumed when coal is burned, the longer the tube, the less the fuel used per square foot of grate surface. But since the combustion of oil is completed so much more quickly than that of coal, when a coal-burning locomotive is converted to an oil burner the area of the fire-box must be increased, and the tubes shortened, to attain the highest efficiency. With this arrangement the temperature of the smoke box gases will be lower than that of the steam, showing that the tubes are absorbing all the heat units available. But in locomotives having long tubes and small fire-boxes, the combustion does not entirely take place in the fire-box, some unburned car-

bon passes through the tubes in the form of smoke, and as a result of the low temperature at the rear end of the tubes, this is precipitated in the form of soot. This makes necessary frequent sanding of the flues to remove the soot, and also lowers considerably the evaporation of water per lb. of oil fired.

The accompanying report gives an interesting comparison between passenger locomotives and freighters of the consolidation and mallet types.

Class of engine.....	10 wheel.	Consoli- dation.	Mallet consoli- dation.
Service .....	Passenger	Freight	Freight
Date of test.....	May, '08	June, '09	Nov. '09
No. single trips.....	2	2	2
Time of test.....	17hr. 39m.	21hr. 23m.	29hr. 2m.
Running time .....	13hr. 55m.	12hr. 59m.	18hr. 11m.
Miles run .....	315	174	174
Average steam pressure .....	196.0	196.1	194.5
Smoke box tem. F.....	797	738.5	451.3
Water evap., gal.....	44147	48103	91087
Water evap., lb.....	367642	400858	759058
Oil burned, gal.....	3951.6	4328.4	7692.1
Oil burned, lb.....	31613	34627	61537
Evap'n lb. water per lb. oil...	14.14	13.95	15.04
Lb. water evap. per sq. ft. heat, surf. per hr.....	8.698	8.809	6.392
Lb. oil burned per sq. ft. heat, surf .....			
No. cars in train .....	7	14.5	24.5
Weight train, tons.....	342	481	1056
Gross ton mileage.....	107730	33694	183744
per hr.....	0.749	0.761	0.518
Water evap. per 1000 ton mi., per hr.....	0.748	0.761	0.518
gal .....	409.79	574.75	495.73
Water evap. per 1000 ton mi., lbs. ....	3413	4790	4131
Fuel oil burned per 1000 ton mi., lbs. ....	34.90	48.40	39.51
Fuel oil burned per 1000 ton mi., lbs. ....	279.20	387.20	316.08
Boiler efficiency, per cent.....	73.84	72.83	78.52
Max. i. h.p. ....	1719	1470	2486
Mean i. h.p. ....	1368	1222	2057
Engine No. ....	231	2564	4001
Size cylinder, in.....	22x28	22x30	26 & 40x30
Diam. of drivers, in.....	63	57	57
Weight locomotive, lb.....	203300	208000	425900
Weight on drivers, lb.....	160000	187000	394150
Weight of tender, lb.....	138070	134745	169765
Heating surface, sq. ft.....	2994	3403	6394
Feed water heater, heating sur- face, sq. ft.....			1221

## CHAPTER IX.

### OIL IN THE SUGAR AND RUBBER INDUSTRIES.

Sugar cane as grown in Hawaii, Mexico, Louisiana, and the West Indies, is made into sugar by extracting the juice from the cane and putting it through the processes of extraction of the juice, clarification, evaporation and separation of the crystals.

Analyses of the ripe cane gives the following average: Sugar, 14 per cent; water, 74 per cent; fibre, 12 per cent.

This fibre or bagasse is used as a fuel, and in many cases special furnaces are required in order to obtain efficient results. To burn the bagasse direct as it comes from the crushers, elaborate and expensive arrangements were invented and placed on the market. The planters would be obliged to make radical changes in their plant equipment to take advantage of these improvements and were content to pay a high price for coal or wood. Fuel oil then came on the market, and owing to its low cost was most welcome to the planter.

Owing to the condition of the bagasse the planter was getting about two-thirds of its heat value, and found it necessary to buy an additional fuel.

From the analyses of dry bagasse it will be seen that there are sufficient heat units to supply all of the power required.

The following table gives the analyses and heat values of bagasse from different localities:

Place.	Moisture.	C.	H.	O.	N.	B.t.u. of lb. of dry ba-	
						Ash.	gasse.
Mexico .....	49.10	43.74	6.08	48.61		157	8300
Cuba .....	42.50	43.61	6.06	48.45		188	8240
Hawaii .....	44.20	44.92	6.27	46.50	.40	190	8380
Louisiana.....	51.80						8371

Only a small percentage of the plants in Hawaii are required to use additional fuel. This is partly due to the fact that the plants are more modern and up to date than the plants in Mexico and Louisiana. It is interesting to note that in the plants that do use oil as an additional fuel require only from 1½ to 2 gallons of oil per ton of cane treated, while some plants in Mexico are using as high as 10 gallons of oil per ton of cane treated.

From the following formula the approximate B.t.u. may be calculated:

$$\text{B.t.u. per lb. of bagasse} = \frac{8550F + 7119S + 6750G + 972W}{100}$$

Where F = per cent fibre in cane, S = per cent sucrose, G = per cent glucose, W = per cent water.

Reports from the Java fields show that with a high dilution by maceration and heavy pressure the bagasse furnishes all of the steam requirements without the use of additional fuel.

In the Louisiana fields, where the cane has about 10 per cent fibre, and the average extraction is 75 per cent, the bagasse has a value of 3300 B.t.u. as it comes from the mill. Deducting the losses due to furnace conditions, amounting to about 33 1/3 per cent, there is only 2200 B.t.u. available for the generating of the steam.

Assuming that it requires 1½ horsepower for each ton of cane handled in 24 hours, and that a 2000 ton plant requires 3000 h.p., and that only two-thirds of the heat units can be counted upon, it will be seen more fuel is required.

Now, then, how much oil will be required? Under boiler plant conditions at a modern steam plant 1.28

lb. of oil are consumed per boiler horsepower—and 1000 additional horsepower being required, the amount would be 128,000 lb. at 8 lb. to the gallon = 16,000 gals., ÷ 2000 tons of cane = 8 gallons of oil to one ton of cane. This is a fair average of the Louisiana and Mexican mills.

Figure 65 shows a Dutch oven front fitted to a Babcock & Wilcox boiler, with the burner placed through the front. This arrangement is giving excellent results at Ingenio El Modelo, Vera Cruz, Mexico.

Some of the sugar mills divide the boilers into bagasse burning alone, and oil alone.

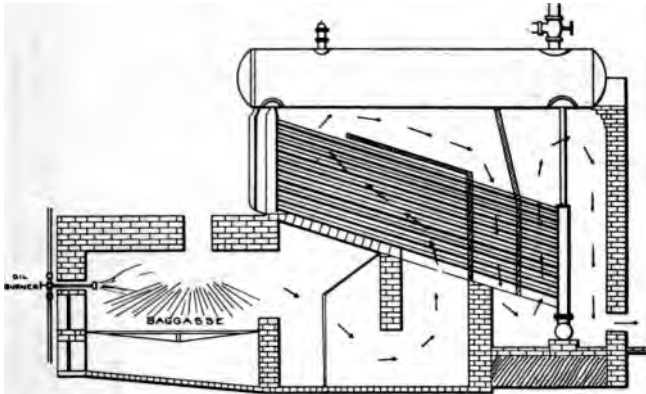

Fig. 65. Dutch Oven for Burning Oil and Bagasse Under B. & W. Boiler.

It is not necessary to have a special design of furnace to burn fuel oil in conjunction with the bagasse, the burner being placed through a hole in the boiler front, above the fire doors, and pointed in such a position as to allow the flame to pass through the flame from the bagasse. It should not come in direct contact with the bagasse as carbon would form.

Some oil burners are installed at the rear end of the furnace, the flame passing towards the front. This method has been proven very satisfactory, especially when arrangements are made for supplying an additional air supply to complete the combustion of the oil.

## Oil, Coal and Baggage Test, Using Mexican Guayule.

Observations.	Oil Test No. 1	Oil Test No. 2	Oil and Baggage
Steam pressure at gauge in lb.....	95	100	90
Oil pressure at burners in lb.....	40	40	
Temperature of feed water.....	167° F.	178.8° F.	160° F.
Temperature of gas at base of stack.....	550° F.	360° F.	550° F.
Temperature of oil at burner.....	130° F.	130° F.	130° F.
Kind of fuel.....	Rosita* washed	Potrero crude	Guayule Rosita
Gravity of oil.....	18° B		
Percentage of mixture (coal).....			Baggage 46.2% Coal
Weight of fuel as fired (kilo).....	1679	1935	795 Baggage 1795
Total weight of water fed to boilers in kilos.....	11024		8944
Weight of water evaporated per kilo of fuel as fired	10.9	15.4	Coal 6.56
Equivalent evaporation from and at 212 deg. F.....	7.15	16.6	Baggage 1.09 Coal 7.15
			Baggage 2.07

\*Analysis: Fixed Carbon, 60.80 per cent; Volatile Matter, 18.95 per cent; Ash, 19.80 per cent; Moisture, 45 per cent.



In Mexico the guayule plant contains considerable rubber. After this plant has been treated, and the rubber extracted, the refuse or bagasse is spread over the ground to dry, and is then used as a fuel. This bagasse when dry has a large percentage of volatile and combustible material, as may be seen from the following analyses.

Fixed carbon .....	14.72%
Volatile and combustible material .....	79.39%
Ash .....	8.89%
B.t.u. per lb. of dry bagasse.....	4218

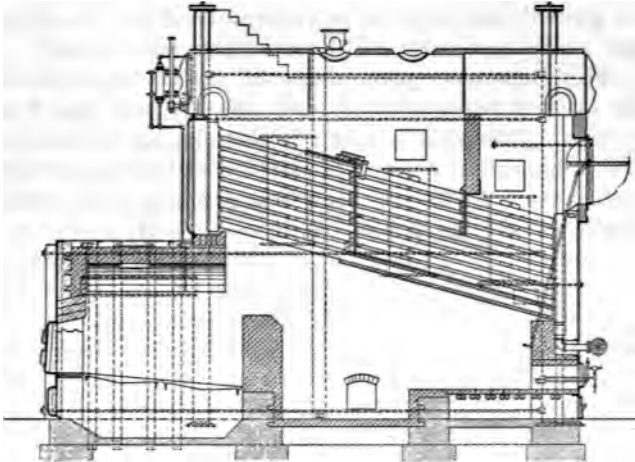

Fig. 66. Babcock & Wilcox Boiler with Furnace for Burning Bagasse or Wood with Oil.

Owing to the poor facilities for drying and storing, only a small percentage of the heat value is realized when this fuel is burned under the boilers. If it were possible to thoroughly dry this bagasse under practical and economical conditions, there would be sufficient heat value in it to supply all of the power required at the rubber extracting plant. But this is not the case, and it is necessary to purchase other fuel.

The first factory to experiment with oil as fuel in conjunction with guayule was at the Cia Explo-

tadora de Coahuilense, S. A., Parras, Mexico. In order to determine the economic results a series of tests were conducted, first with coal alone, second with oil alone, third with oil and bagasse, fourth with coal and bagasse, fifth with oil alone.

This report shows the weights in kilos, as the metric system is used exclusively in Mexico. The results obtained during the test of oil and bagasse were not as favorable as had been anticipated, although the percentage of bagasse consumed was higher with oil than with coal. Probably a higher percentage of bagasse could be consumed after more experience had been gained; and it must be remembered that the bagasse as burned contained over 40 per cent water.

The increased percentage of boiler horsepower with oil and bagasse over coal and bagasse was 20.8 per cent. This gain would warrant closing down two 110 h.p. boilers in a plant of the size of the one tested. Further tests have not been made along these lines because of the disturbed conditions in Mexico.

## CHAPTER X.

### SMELTING FURNACES FIRED WITH OIL.

Many difficulties attend the use of coal or coke in reverberatory and roasting furnaces used for smelting and refining metal ores. If coking coal is used, the volatile matter is quickly driven off, leaving a heavy bed of slow-burning coke. Ordinary coal reduces the atmosphere of the furnace at each charge, producing a period of incomplete combustion, during which no sulphur can be oxidized by the oxygen of the air. This feature is particularly undesirable in reverberatory furnaces in which copper ores are treated. If pulverized coal is used much difficulty is encountered in regulating the proper amount of air. Trouble is also caused by the settling of ash and unburned fuel on top of the charge and by the clogging of the flues.

The use of fuel oil obviates all these difficulties, for when the fires are regulated, the flame is clear and steady, the furnace temperature even, and there is no smoke or soot. This desirable condition may be maintained for weeks, allowing the sulphur in the ores to combine with the oxygen of the air at all times. Other advantages accruing from the use of oil fuel in reverberatory furnaces are its cleanliness, low cost of handling, freedom from sulphur, and the increased capacity of production made possible by its use.

The following table shows a record performance at the Steptoe plant, McGill, Nevada, on December 17, 1911:

**Record of a Run of Reverberatory Furnace and Analysis of Charge.**

Total charge per furnace day, tons.....	666
Oil fired per furnace day, bbl.....	421
Coal equivalent of oil fired, tons.....	124.00
Total charge per bbl. of oil, tons.....	1.58
Oil, bbl. per ton of total charge .....	0.63
Equivalent gross coal, as percentage of total charge.....	18.60

**Components of Charge as Percentage of Total Charge.**

Calcine .....	60.1
Seconds .....	16.8
Converter hot slag .....	9.0
Fettling .....	3.0
Limestone .....	9.6
Flue Dust .....	0.6

**Slag (Assay and Analysis).**

Cu .....	0.40
SiO .....	44.00
Fe .....	34.30
CaO .....	8.60
AlO .....	7.40
Oxygen rates .....	2.72
Grade of matte, per cent Cu.....	40.40

Draft.	Water inches.
Bridge .....	0.85
Throat .....	0.88
Stack .....	1.25
Temperature of verb, degrees F.....	1010
Infusibility factor of calcine .....	1.5
Burners, large Steptoe, high pressure .....	7

In addition to these many inherent advantages, great economy can be attained by the use of a waste heat boiler in conjunction with oil firing, savings of as much as 50 per cent of the fuel having been recorded by this device.

Fig. 67 shows the plan of such a furnace at Cananea, Mexico; the records of a typical run in this furnace show that during a period in which 8140 tons of material were handled, 7003 bbl. of oil were used, of which only 3901 bbl. were chargeable to smelting, the remaining 3102 bbl. being recovered in equivalent steam.

The attached table shows typical operating conditions of two reverberatory furnaces:

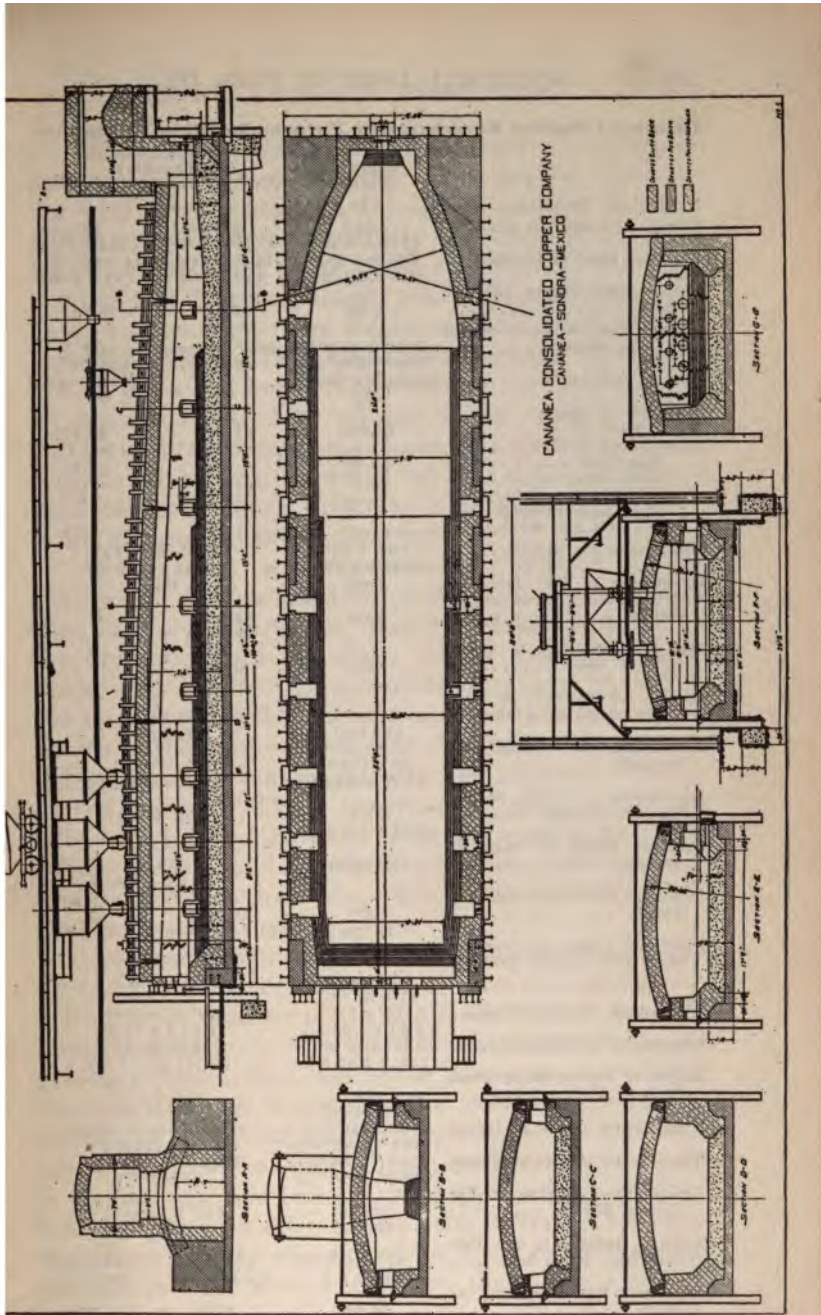

Fig. 67. Plan and Section of Cananea Oil Fired Furnace.

**Details of Modern Reverberatory Furnace Smelting in America.**

	Steptoe (McGill) (Nevada)	
	(Coal) Fired	(Oil) Fired
Number of Furnaces.....	2	5
Average tonnage per day....	192.8 (174.4 T.M.)	289— (216.8 T.M.)
Average weight of Charge....	7½ to 9 tons (6.8-8.2 T.M.)	322— (292.1 T.M.)
Average tons charge per ton Fuel .....	5.86	3.24
Average temperature of charge entering furnace.....	500° to 550°F (260°-288°C)	500°F approx (260°C)
Kind of Fuel used.....	California Crude Oil	California Crude Oil
Character of Charge:		
Calcine (Hot) .....	50.0%	61.8%
Calcine (Cold) .....	.....	.....
Flue Dust .....	50.00	1.2
Conv. Slag .....	.....	9.8
Secondaries (Cold)....	.....	12.5
Flux and Pettleing Ores (Cold and Wet).....	.....	15.2
Dimensions of Hearth.....	100' x 19' (30.48 x 5.79 m)	120'-10" x 19' (86.88 x 5.79 m)
Dimensions of Fire Box....	None	None
Top of Grate Bars to top of Bridge .....	None	33-1-4" (84 cm)
Top of Grate Bars to under- side of Roof .....	None	85-3-8" (217 cm)
Height of "Verb" or Vul- catory above Skim Plate..	36-1-2" (93 cm)	36" (91 cm)
Dimensions at Throat of Furnace .....	7' x 1'-9" (2.13 x 5.3m)	6'-10" x 8' (2.08 x .91 m)
Dimensions of flue beyond Throat (damper flue)....	7' x 6' (213 x 183 cm)	(Not Given)
Draft in inches of water at Bridge .....	(No data)	.2"-5" (.5 cm-1.3 cm)
Draft in inches of water at Throat .....	.18" (.38 cm)	.7"-1.2" (1.78-3.05 cm)
Draft in inches of water— Main Flue beyond Boilers.	.9" (2.29 cm)	1.25" (3.18 cm)
Dimensions of Main Flue... 115 sq. ft.	10' x 12' (3.04 x 3.66 m)	29'-3" x 8'-6" (8.91 x 2.59 m)
Dimensions of Chimney.....	187' x 12'-6" (57. x 3.81 m)	300' x 15' (91.44 x 4.57 m)
Height of top of Stack above Grate .....	198' (60.35 m)	316'-9-1-2" (96.55 m)
Temperature of Gas at Bridge	2700°-2800°F (1482°-1538°C)	2700°-3000°F (Est) (1482°-1649°C)
Temperature of Gas at Throat	2300°-2400°F (1260°-1316°C)	2200° F. (approx.) (1205°C)
Temperature of Gas at Far Side of Boilers .....	500°F (260°C)	800°F (approx) (427°C)
Average Boiler h.p. per Fur- nace from waste heat ....	971 h.p.* (984 C.V.)	486 h.p. (493 C.V.)
Per cent Fuel recovered as steam .....	56.62	32.3
Per cent Fuel recovered from ashes .....	None	5.05
Ratio of Concentration.....	4.96	3.31
Tons charge per million B.t.u.	0.1574	0.122

\*Economizers are installed at this point beyond boilers.

The use of fuel oil in blast furnaces presents much more serious difficulties. In the process of smelting with these furnaces, solid carbon plays a very important part, both mechanically and chemically. The lumps of coke used serve to keep the charge from becoming too densely packed, thus permitting the hot gases to penetrate more freely; and the incandescent carbon performs certain chemical functions which need not be discussed here. Thus coke or charcoal cannot be entirely replaced by oil fuel in the blast furnace; and while a few experiments have been conducted, with economical results, in which oil and coke have been used together, much difficulty has been encountered in the slagging of the furnace tuyeres.

These tests were carried out without radical changes in the construction of the furnace; coke was used in the ordinary way, and the oil was injected at the tuyeres with a hot blast. Other tests have been made with specially constructed furnaces, in which the oil is supposed to be converted into a gas at the mouth of the tuyeres by means of elaborate atomizers, the combustion taking place in the channels leading to the tuyeres. These experiments were carried on with high gravity oils; and while the results were satisfactory from the chemist's standpoint, the expense was too great to make the method commercially practicable.

Another difficulty in the way of using oil as a fuel for blast furnaces lies in the fact that if the burners are placed in the bottom of the shaft, the burner tips will soon be melted off. The operation at the start may be perfectly satisfactory; but as the temperature increases the zone of fusion is lowered, the molten metal cannot withstand the great weight of material in the shaft above it, with the result that it is forced down until in contact with the burner tips, with the result that the latter are burned off. Even if this extreme difficulty does not arise, the sagging of the charge is soon great enough to close the air channels upon which the oil depends.

There are at present two reverberatory furnaces, 19x12, constructed on a concrete base, 3 ft. 6 in. thick, on top of which are 24 in. of silica. The walls of the furnaces are made of silica brick 2 ft. 10 in. thick, outside of which are 5 in. of fire clay brick.

These furnaces have shown a capacity of 400 tons per day of 10 hours, making 40 to 42 per cent of matte, the slag averaging from 43 to 45 per cent  $\text{SiO}_2$ , 28 to 30 per cent Fe, and 7 to 10 per cent CaO.

Three oil burners of the Steptoe type are required, the oil being atomized with air, supplied by two Root blowers, having a capacity of 3600 cu. ft. per minute at 48 oz. pressure.

Two charges of  $5\frac{1}{2}$  tons each are dropped in the furnace every 30 minutes without interfering with the operation of the burners.

The draft is regulated so as to have the flame reach the middle of the furnace, the shaft readings in inches of water being 0.2 at the doors, .08 at the throat, 1.6 in the main flue and 0.9 at the base of the stack.

The oil consumption per furnace is from 12,500 to 13,500 gal. per day when smelting from 350 to 400 tons of charge.

The gases from the furnaces pass into a silica brick flue, 8x19 ft., and are then distributed to a battery of Sterling waste heat boilers. There are six boilers, five of which are in use when the two furnaces are in operation.

A thermal efficiency of about 35 per cent is obtained in steam from the oil burned in the furnaces.

At the El Paso smelter oil is used as fuel in the reverberatory furnaces. They are 19x100 ft., and have a capacity of about 350 tons per day. The burners are "Home-Made Type," and from general appearances are not very efficient. No data could be obtained regarding the oil used per charge.

The matte averages 42 to 45 per cent copper, and has run as high as 55 per cent.

Fettling of the reverberatories is done with high silica, copper sulphides, ores averaging 70 per cent  $\text{SiO}_2$ , 2 per cent Fe, 3 per cent S, 7 per cent Cu. The





THE NEW YORK  
PUBLIC LIBRARY  
ASTOR, LENOX  
TILDEN FOUNDATIONS

THE  
PUBLIC  
ASTOR, LENOX  
TILDEN FOUNDATIONS

fettling is thrown in at the side doors, except at the bridge, where there are fettling hoppers that permit the material to be dropped in through the roof.

Mining companies as a rule are quick to adopt new and improved machinery, but they do not seem to "get on to" the latest developments in oil burning machinery. The pressure type of oil burner would show wonderful savings, and improve the furnace conditions in reverberatory furnace to such an extent as to surprise the general managers, but the writer has no knowledge of any being in use at this writing.

In the roasting furnaces the old type burners are still in use, while we have a new rotary oil burner that might have been made to order for such furnaces. Still the mining companies have evidently not discovered this type of burner. The users of mechanical roasting furnaces would do well to investigate the rotary burner.

As explained in a previous installment, it is difficult to use oil as a fuel for blast furnaces. Many engineers have attempted to design a blast furnace

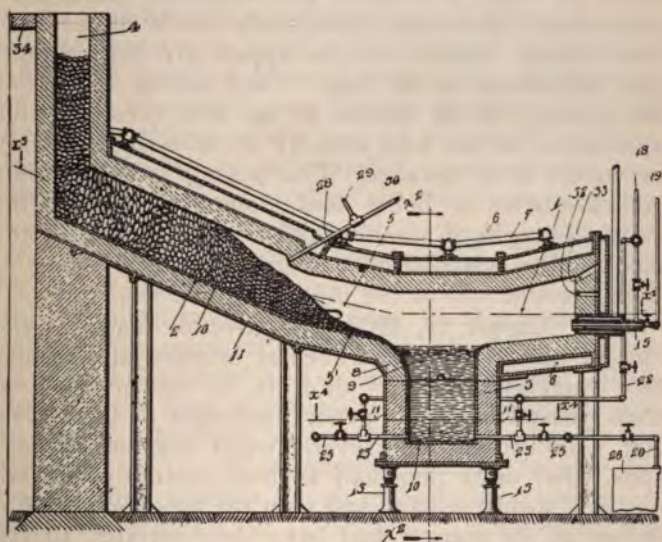

Fig. 68. Riverall Furnace for Smelting with Oil.

in which this cheap fuel could be used, one of the first of these experiments to come to the attention of the writer was conducted at Los Angeles by Mr. E. Riverall. Fig. 68 shows sectional views of his furnace for smelting ore with oil.

The ore and flux are introduced through a charging door directly under the stack, and pass down the inclined bottom of the furnace, the molten metal and slag being collected in the crucible at the lower end, from which they can be capped off. The oil is introduced with steam, through a number of jets placed on the top of the furnace as shown. The furnace described is 40 ft. in length and 2 ft. in the clear, inside. The inventor points out that during the past decade numerous attempts have been made to accomplish this process. It is true, pig iron has been secured by experimenters with oil as fuel, but in no case has more than 150 lb. of the charge been reduced at one time, and even then coke or charcoal had to be introduced to the extent of 10 per cent, or thereabouts, in order to bring about the necessary chemical reaction. Heretofore all effort to produce this important material in commercial quantities, using only crude oil as fuel, have failed, because of the apparently insurmountable difficulties in the way. Chief among these was the getting rid of oxygen in the iron ores, and the application of the heat directly upon the entire body of the ore to be reduced. This process is both simple and inexpensive, being less complicated than the cupola or upright smelter, and requiring none of the cumbersome machinery incidental to the hoisting of both ore and fuel to the top of the flue.

On August 19, 1902, Mr. Riverall made a trial run in his 50 ton experimental smelter at Tropic, Los Angeles County, California, in the presence of Prof. Joseph Kirkham, general manager of the Pacific Art Tile Works, and several other responsible persons. For more than half an hour molten metal ran out in a steady stream, and then the furnace was shut down, as its success had been demonstrated to the

satisfaction of all concerned. The resultant slag con-  
sisted of 45 per cent silica and alumina, 25 per cent  
of lime, and 30 per cent of iron and other elements.  
The time spent in the furnace in place of the  
smelter is its economy.

A patent was recently granted to Mr. Frank  
Bachman of Newark, England, for a furnace for  
roasting smelting or otherwise treating ores.  
In this furnace the furnace and its lining are  
so arranged that the principle of heating the  
ores is practically the same as in Mr. Wallace's  
furnace. At all times the heat is applied to the  
ore, and therefore the results are more satisfactory.

One of the most successful designs of furnaces  
used with this oil is a melting cupola invented by Mr.  
Wallace Dow, of the Dow-Dodge Engine Company,  
Alameda, California. With this cupola the results  
at his factory, and in only seventy days of operation,  
he decided on experiments with fuel oil as a means  
which increasing business made necessary. The  
results show the design which he adopted. Its economy and  
economy have been remarkable.

As may be seen by reference to the drawing, com-  
plete combustion is accomplished before the fuel en-  
ters to the cupola. A small combustion chamber on  
one side is operated by one burner, the flame of which  
attacks the charge at the base of the shaft. On the  
opposite side is a larger chamber, operated with two  
burners projected at angles, the top burner being  
pointed downward towards the bath and the side  
burner pointing toward the bottom of the shaft. With  
the former burner operating alone, the metal can be  
kept fluid until ready for pouring. In this manner the  
heat is concentrated at the "fusion zone." No trouble  
has been encountered as a result of the charge falling  
down, as the heat is concentrated at one point, and  
the material does not become fluid until it passes the  
fusion zone. It will be noticed that the furnace in-  
clines slightly towards the pit or bath, from which the  
metal can be drawn off as required. In operating the

furnace is first brought up to the required temperature, all burners being used. The air required for the blast is furnished by means of an electrically driven No. 4 Root blower, an air pressure of 8 oz. being used while heating up the furnace. After about 40 minutes the charge is introduced in the regular manner, and the air pressure increased to 14 oz. The temperature of the furnace can be easily regulated; white cast iron requires about 2100 degrees F., and gray cast iron about 2300 degrees F. The capacity of this furnace is 4 tons per hour; the amount of oil consumed is 20 gal. per ton of castings. The operation has been

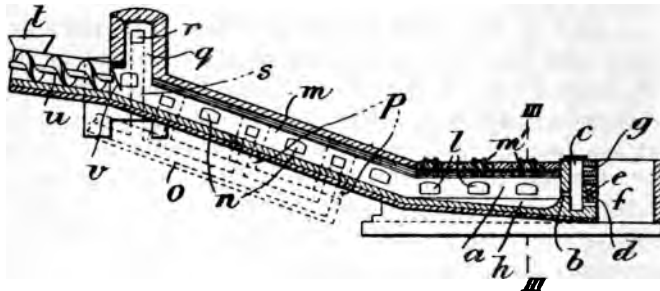

Fig. 69. Buchholtz Furnace.

completely successful, melting each day the amount of iron required. Not only is money saved, but valuable space and labor as well. The molders do not have to wait for a heat, for by the use of the auxiliary burner the charge can be kept ready to pour for many hours.

**Table of Determinations.**

Oil as Fuel.		Per cent
Silicon (Si)	.....	2.27
Graphite carbon (C)	.....	2.51
Combined carbon (C)	.....	.51
Phosphorus (P)	.....	.78
Sulphur (S)	.....	.059
Manganese (Mn)	.....	.57
Coke as Fuel.		Per cent.
Silicon (Si)	.....	2.46
Graphite carbon (G)	.....	2.41
Combined carbon (C)	.....	.36
Phosphorus (P)	.....	.79
Sulphur (S)	.....	.111
Manganese (Mn)	.....	.53

The above analyses, made by Smith, Emery & Company, chemical, inspection, and testing engineers of San Francisco, show clearly that the quality of the cast iron produced by the oil operated furnace is better than that produced by the coke fired furnace.

The graphite and combined carbon in the coke operated furnace totals 2.77 per cent, against a total carbon of 3.2 per cent in the oil operated furnace, or approximately 10 per cent increase in carbon. The decrease of sulphur in the oil operated furnace is also important, being less than one-half that of the coke operated furnace. Sulphur causes the carbon to take the form of combined carbon: increases hardness, brittleness, and shrinkage, and also has a weakening effect. When silicon is below 1 per cent, even 0.06 per cent sulphur makes the iron dangerously brittle. The advantage of low sulphur and high silicon is thus apparent.

---

## CHAPTER XI.

### METALLURGICAL AND SHOP FURNACES.

Scientists and engineers have for many years been searching for a cheap and clean method of refining ores and bullions.

Electricity was at one time looked to for the solving of this problem. A great many economical results were obtained by the use of electricity, but to buy or generate electricity at mining camps or small shops was out of the question. For commercial use it was found to be too expensive.

From the results that are being obtained with fuel oil it will tend to prove that the fuel problem has been solved. Furnaces have been designed to meet the requirements in every case where an ore or metal is to be melted and refined. Muffle types of furnaces are used where the flame or gases would be injurious to the metal treated. For the assayer who may wish to do more than one class of work at a time, the three muffle furnace has been devised. Here he may do crucible work or melt in one muffle, scorify in the second, and cupel in the third. Or only one muffle may be used.

Some of the results obtained by mining companies were most gratifying. One report is as follows:

“We have made one more melt with about the same results as we go in the test run. We use for a melt 550 lb. of precipitate, yielding about 6300 oz. metal (975 fine Au. and Ag.), 20 gal. of oil against 1000 lb. of coke at \$16 per ton; oil at 15c per gal. at the plant. The slags from the coke furnace used to



run about \$200 per ton, while those from the oil furnace run between \$12 and \$13, which avoids retreatment."

Another report:

Crucible used, Dixon No. 275.	
Lbs. of precipitate and flux melted.....	1148 lbs.
Hrs. required to melt.....	20 hrs.
Amount of oil used.....	1¾ bbls.
Number of crucibles.....	1
Smelting No. 1, cold furnace, 2 hr. 20 min.....	oil 7 gals.
Smelting No. 2, hot furnace, 50 min.....	oil 3½ gals.
Smelting No. 3, hot furnace, 45 min.....	oil 2⅞ gals.
Smelting No. 4, cold furnace, 2 hr. 05 min.....	oil 6½ gals.
Smelting No. 5, hot furnace, 1 hr. 10 min.....	oil 4 gals.
Smelting No. 6, hot furnace, 40 min.....	oil 2¾ gals.
Smelting No. 7, hot furnace, 40 min.....	oil 2¼ gals.

The slag obtained from these smelts average \$40, this being very low when comparing same with old method with 50 oz. value. Precipitates charged being

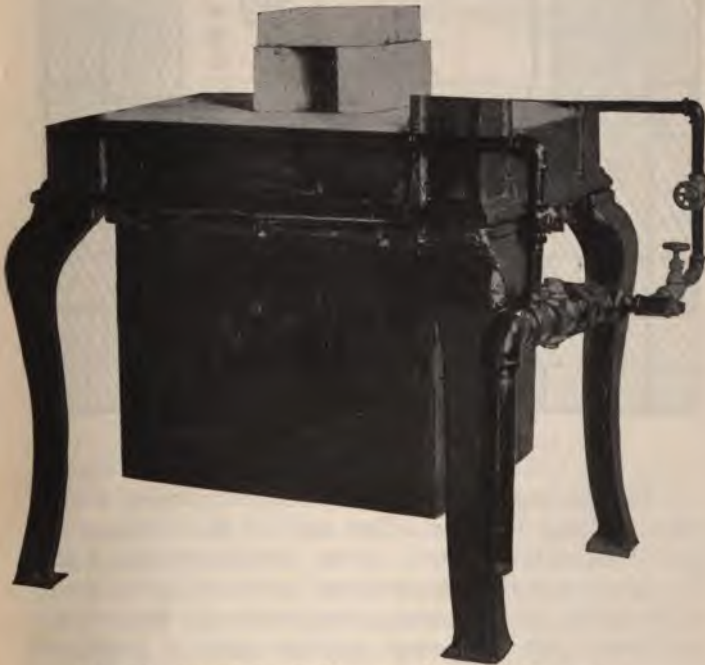

Fig. 70. Oil Burning Forge, General Blacksmithing.

better than 200 fine and bullion 970. The oil used was California crude, of 24 gravity, costing  $6\frac{3}{4}$  cents on the ground here.

From the above data one can readily see at a glance the amount of time and labor saved and the economy effected by using oil fuel.

Other mines have submitted similar reports, showing much time and labor saved, and great economy effected, by the use of oil fuel.

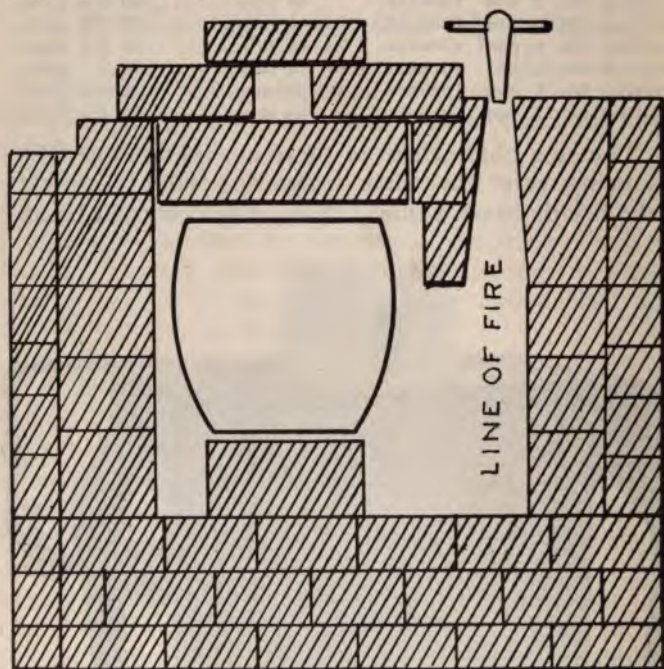
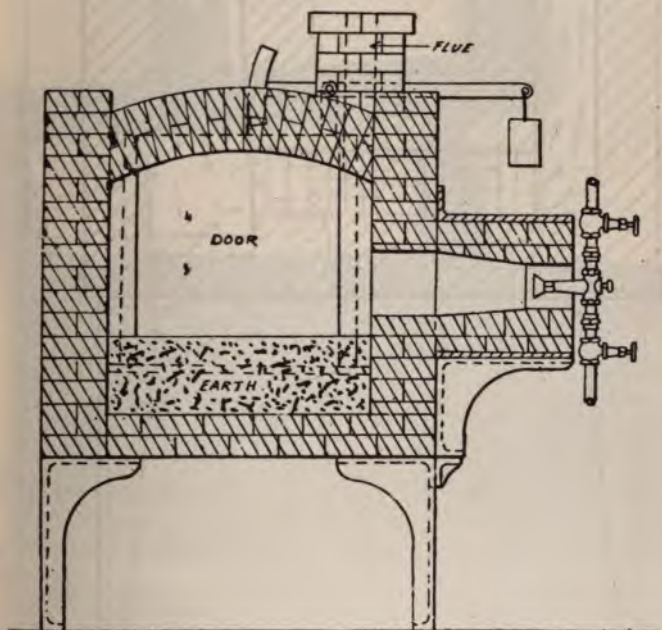

Fig. 71 Cross Section of Crucible Furnace.

Fig. 71 shows the method of constructing a crucible melting furnace. The size of the furnace required depends of course, on the size of crucibles used. The inner walls and bottom are built of a good grade of fire-brick, while common red brick may be used on the outer wall. The top may be made of arch and tapered fire-brick, held in place by an iron band. A

small loop on each side of the band affords a means of raising the cover, in the center of which a small opening must be left for charging or adding flux as required.

Almost any type of an oil burner can be applied to this furnace, the low pressure air type being the most suitable. It will maintain a temperature of over 3000 deg. F., with a fuel consumption of only 3 gallons of oil per hour, using air at 2 lb. pressure. Two



gallons of oil will melt 100 lb. of brass scrap in about 30 minutes, and crucible steel, brass, copper, bronze, silver, gold or nickel can be melted with similar economy and convenience.

Fig. 72 shows a small heating furnace, that is easily made. Doors may be placed at either end. Fig. 73 shows a rivet heating furnace, which may also be used for tempering, annealing, case hardening, etc.

This type of furnace can be run 8 hours on less than 20 gal. of oil. The furnace illustrated is designed to use compressed air for atomizing, for where riveting is being done, compressed air is generally available. In operation, the furnace is first started and thoroughly heated. Then the oil is shut off and about 12 or 20 rivets are thrown in, depending upon their size. The

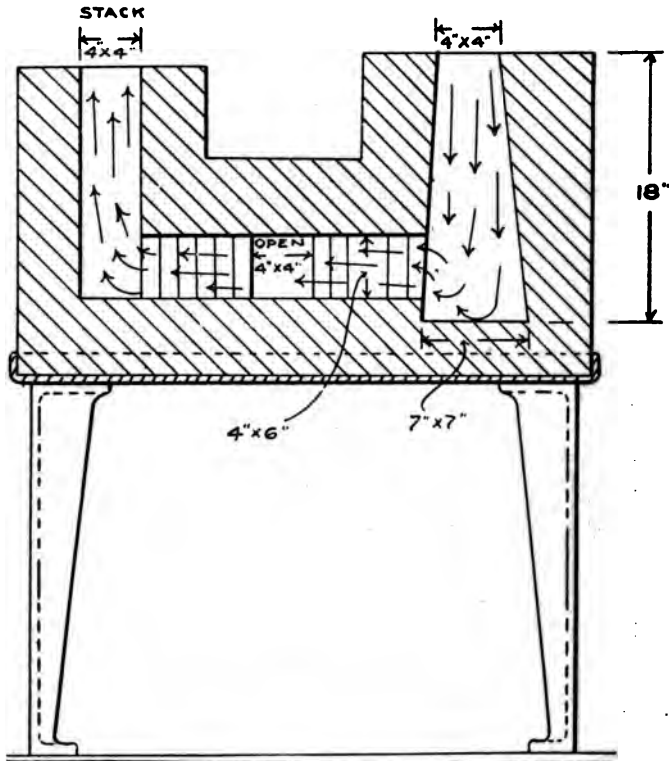

Fig. 73. Rivet Heating Furnace.

rivets must not lie in a heap, but be spread over the bottom of the furnace. The oil is then turned on, and in a few moments the rivets will all be heated to a uniform temperature. When they are driven they will thicken up and fill the hole, and the head and back will form squarely over the rest of the rivet. Being

uniformly hot, the iron is left in good condition and the stress is evenly distributed throughout the rivet, making a good steam tight job.

Fig. 74 illustrates a heat treating furnace which is used by many large manufacturers of machinery. This furnace is arranged with single and double compart-

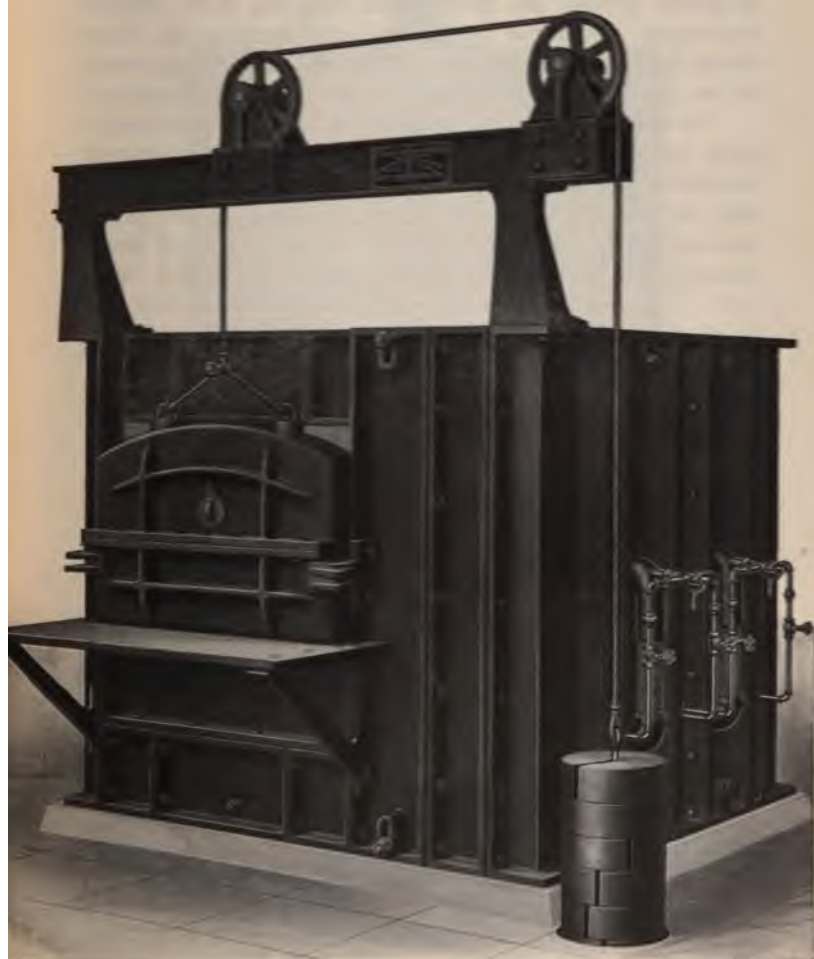

Fig. 74. Large Heat Treating Furnace.

ments, the heating chambers being separated by a solid fire brick wall in such a manner that each chamber can be heated entirely independently of the other. At the side of the heating chamber is the combustion space, into which the burners fire. The heat passes from this space over a bridge wall and along the arch of the heating chamber. Circling this arch, the heat is drawn across the hearth and into the flues, which criss-cross under the hearth, thereby heating the floor of the furnace from above and below, and saving some of the waste heat that would otherwise have been lost.

In the main flue is located the air blast pre-heater pipe; the air passing through this pipe is pre-heated to almost the flue temperature. This effects an economy of fuel, for it lowers the temperature of the gases leaving the furnace, and returns to the furnace a large amount of heat which would otherwise have been lost. The working openings are covered by heavy fire brick doors, encased in cast iron frames flanged and ribbed to prevent warping and cracking. These doors are raised and lowered by a direct counter-balancing arrangement, operating on roller bearings, and when lowered are held firmly against the furnace front by door checks. An opening with a cover is provided in the door for a peep-hole. This furnace is properly designed for all classes of heat treating, as it amounts to a semi-muffle furnace. It gives an even heat throughout the chamber, without any danger from oxidation. Suitable pyrometer holes are provided in the walls and arch. No stack is required, and either oil or coal may be burned.

Fig. 75 illustrates a portable semi-muffle furnace for annealing or general hardening. It is mounted on a self contained oil burning system, requiring only a small amount of compressed air for operation. This air is used to force the oil to the burner, and also constitutes an atomizing agent for the oil. Self-contained furnaces of this type are installed in shops where the work does not warrant the installation of a complete oil burning system.



Fig. 75. Portable Semi-Muffle Furnace.

Fig. 76 illustrates a portable fuel oil burner which gives an intense flame. It is used in many machine shops, boiler and locomotive shops and foundries, for pipe bending, plate bending, starting cupolas, drying moulds and general heating. It is self-contained, and requires but a small amount of compressed air for operation.



Fig. 76. Portable Fuel Oil Burner.

The average jobbing shop uses pit furnaces, the crucibles holding about 200 lbs. A few large manufacturing plants, outside of the rolling mills, still use pit furnaces, but these are, almost without exception, those whose castings are so small or so thin that the drop in temperature due to pouring into a ladle from a tilting or tapping furnace cannot be allowed. The great majority of the manufacturing plants whose aim is large production use tilting or tapping furnaces on account of their greater speed. Few of the users of tilting crucible oil furnaces, tilting oil flame furnaces or oil fired reverberatory furnaces come into the small



jobbing class. Most of the large manufacturers, except the rolling mills, use oil on account of the great speed of melting possible with its use, and in this connection it should be noted that the open flame, oil furnace seems to come nearest to meeting the needs of the large manufacturer who must melt large quantities of red brass.

A reverberatory furnace 5 x 2½ ft. was brought to a temperature of 2700 degrees F. with 2.8 gallons of oil.

Wagon tires from 2 in. to 4 in. wide require about 5 gal. of oil per hour when treating 30 tires.

In a crucible furnace, three 150 lb. pots were brought to a temperature of 3200 degrees F. with 5 gallons of oil. A brass furnace melted 40 lb. of brass in 30 minutes on 6 lb. of oil.

A forging furnace has handled 1 ton of material ready for the hammer on 22 gallons of oil. This was average shop work.

A bolt heading furnace turned out 600 1¼ in bolts per hour on 6½ gallons of oil. The bolts were 6 in. long, consequently the fuel consumption was only 10.4 gallons of oil per ton of material. The same furnace, operating two machines, heated ¾ in. bolts at the rate of 1380 per hour. A large rivet heating furnace has heated 600 rivets an hour on a consumption of 3 gallons of oil, and an annealing furnace treated 1 ton of material on 10.5 gallons of oil.

In an air furnace, the time of getting out a heat was greatly reduced, and the capacity of the plant increased by the use of oil. One malleable iron foundry which used 1000 lb. of coal per ton of iron and took ten hours to a heat is now using 50 gallons of oil per ton of iron and running heats in less than five hours. In general blacksmith practice at the Mare Island Navy Yard an economy of 60 per cent in fuel cost was effected, 40 per cent more work was done by the same number of men with oil instead of coal fuel. A piece of armor plate 10 ft. long, 4 ft. 6 in. wide, and 6 in. thick, was heated in eighty minutes, the job requiring eight hours when coal was used as a fuel.

**Average Results With Oil in Tilting Furnaces.**

Material.	oz. Weight.	Heats per day	Oil per 100 lbs.
White cast iron .....	350	4	2½ gals.
Gray B iron .....	350	4	2½ "
Copper .....	450	5	1½ "
Gun metal .....	450	7	1½ "
Red brass .....	450	6	2 "
Yellow brass .....	450	8	2 "
Steel .....	132	3	14 "
Nickel .....	114	4	13 "
Malleable iron .....	170	4	5 "
Aluminum .....	500		1½ "
Silver .....	1000	1	4 "

The following report was taken from "Brass Furnace Practice," issued by the U.S. Bureau of Mines. This is a complete report showing the operation of various furnaces with different fuels:

**Heating Values of Fuels Used in the Foundry.**

	B.t.u.
Coke, anthracite coal, bituminous coal.....per lb.	13,000
Fuel oil .....	19,000
Natural gas .....	per cu. ft. 1,000
City gas .....	per cu. ft. 625
Producer gas .....	per cu. ft. 120

**Quantities of Different Fuels Required to Heat 1 Hundredweight of Brass to Pouring Temperature.**

Fuel.	Type of furnace.	Fuel required per 100- weight. Pounds	Percentage of theor- etical heating value.
Coke.....	Forced-draft tilting .....	13	15½
Coke.....	Natural-draft pit .....	133	1½
Anthracite coal...	Natural-draft pit .....	25	12½
Anthracite coal...	Forced-draft pit .....	125	1 3/5
Bituminous coal..	Forced-draft reverberatory	18	11
Bituminous coal..	Forced-draft reverberatory	88	2½
Gallons.			
Oil.....	Reverberatory .....	1.11	16
Oil.....	Square-pit .....	7.8	2½
Cu. ft.			
Natural gas.....	Open-flame .....	200	13
Natural gas.....	Tilting crucible.....	480	7½
City gas.....	Pit .....	256	16
City gas.....	Pit .....	650	6½
Producer gas.....	Pit .....	3,500	6

Pyrometers are of great value in connection with the heat treatment of steel or other metals, as they make possible the accurate determination of the high temperatures encountered. When heating for hardening, the temperature can be maintained steadily at the point which has given the best results in practice. The correct hardening temperature for any carbon steel can be determined accurately by the use of a pyrometer.

Comparative Results With Coke Furnace and With Oil Furnace.

Alloy No. ....	Analysis.	Coke furnace.			Oil furnace.				Average metal loss. Per cent.	
		Time of heat...	Metal charged	Metal lost....	Time of heat..		Metal charged	Metal lost....		
					H.	M.				Lbs.
1 .....		.....	...	...	1	45	1,003	0.4	0.7	
					1	20	1,000	1.0		
					1	25	1,000	0.8		
2 .....		3	45	207	7.0	2	5	842	4.1	5.2
						1	30	840	6.3	
3 .....		3	30	208	15.0	1	35	840	7.3	7.3
						1	55	500	1.2	
4 .....		2	30	250	3.2	1	15	500	2.3	1.6
						1	45	538	1.4	
						1	35	600	1.0	
5 87 Cu, 5 Zn, 5 Sn, 3 Pb.		4	00	274	0.9	1	0	606	1.8	1.6
						1	10	587	1.8	
						2	0	1,459	2.8	
6 Red brass..		3	30	250	3.3	2	0	1,460	3.8	3.3
						1	50	1,220	3.5	
						1	0	722	0.6	
7 .....		2	30	250	1.6	1	5	800	1.1	1.0
							45	598	1.3	
						1	20	708	3.1	
8 .....		45	249	0.6		1	0	810	2.3	2.8
						1	10	803	3.2	
						1	35	800	1.9	
9 .....		3	30	262	1.2	1	5	777	1.7	1.7
						1	30	762	1.5	

Total average loss in coke furnace, 3.42 per cent; in oil furnace, 2.48 per cent.

Average output of metal from coke furnace, 81.6 pounds per hour; from oil furnace, 591 pounds per hour.

When testing a piece of steel with this apparatus, the temperature indicated by the meter rises uniformly until the metal is heated to a certain point, at which it continues to absorb heat without appreciably rising in temperature. This is called the "point of decalcescence." At this temperature, the indicating pointer of the meter remains stationary, the added heat being consumed by internal changes. When these changes are completed, the temperature again rises. The point of decalcescence should be carefully noted, and as soon as temperature begins to rise above it the steel should be removed from the furnace and allowed to cool slowly, for overheating at this critical point has a tendency to lessen the hardness of the steel. When it has

Comparison Report From Actual Practice on Brass Furnaces.

Item.	Large, natural-draft, coal furnaces.	Small, natural-draft, coal furnaces.	Crucible, tilting, oil furnace.	Crucible, forced-draft coals furnace.	Reverberatory oil furnace with two burners.
Diameter or inside dimensions.....	31x31	27x27	34	36	54x96
Height, inches.....	43	36	27½	32	79
Thickness of fire-brick lining, inches.....	4½	4½	6½	5	8
Kind of cover.....	Cast iron.	Cast iron.	Fire brick.	Fire brick.	.....
Diameter or dimensions of cover, inches.....	25x25	22x22	27½	32	.....
Depth of covers, inches.....	3½	4	3	4	.....
Thickness of fire-brick lining of covers, inches.....	2	2	3	4	.....
Size of flue, inches.....	8x10	7x7	.....	.....	.....
Height of ash pit, inches.....	24	19	.....	19	.....
Width of ash pit, inches.....	22	20	.....	22	.....
Length of ash pit, inches.....	42	27	.....	.....	.....
Size of crucible used.....	No. 200	No. 80	No. 275	No. 225	.....
Life of crucible, number of heats.....	12	18	22	21	.....
Moisture in fuel, per cent.....	4.16	4.16	.....	2.50	.....
Volatile matter in fuel, per cent.....	3.10	3.10	.....	11.50	.....
Ash in fuel, per cent.....	10.57	10.57	.....	0.9	.....
Sulphur in fuel, per cent.....	.....	.....	.....	.....	.....
Specific gravity of fuel.....	.....	.....	0.9105	.....	0.9155
Analysis of fuel, "B.".....	.....	.....	24	24	24
Analysis of fuel, "B. t. u. per pound....."	12,900	12,960	19,350	12,750	19,350
Fuel used.....	Egg coal.	Egg coal.	Crude oil.	Coke.	Crude oil.
Blast pressure.....	.....	.....	30 ounces.	2 inches of water.	27 pounds.
Heats run before refining furnaces.....	300	450	.....	.....	200
Length of working day per furnace, hours.....	7	7	7½	7	7
Total metal charged per furnace, pounds.....	1113.5	724	3228.5	3016.5	6565
Nature of charge.....	New metal.	New metal.	New metal.	New metal.	Scrap.
Metal lost per day, pounds.....	6.75	44	134	191	3284
Gross losses, per cent.....	0.61	0.63	0.42	0.64	5
Copper in metal charged, per cent.....	90	90	90	90	88
Tin in metal charged, per cent.....	7	7	7	7	5.5
Zinc in metal charged, per cent.....	3	3	3	3	5.0
Lead in metal charged, per cent.....	.....	.....	1.55	1.55	1.5
Elastic limit of alloy produced.....	16,807	14,769	14,769	15,278	.....
Tensile strength of alloy produced.....	47,798	42,883	42,831	42,831	.....
Elongation of alloy produced, per cent.....	65.90	30.58	34.70	20.05	.....
Reduction of alloy produced, per cent.....	64.34	34.40	35.36	24.51	.....
Number of heats.....	3	3	5	5	3
Metal charged in first heat, pounds.....	556.75	251.5	711	611	3,740
Metal charged in second heat, pounds.....	556.75	251.5	702.5	600.5	2,825
Metal charged in third heat, pounds.....	.....	221	704.5	630	.....
Metal charged in fourth heat, pounds.....	.....	.....	710.5	605.25	.....
Metal charged in fifth heat, pounds.....	.....	.....	400	600	.....
Total metal charged per day, pounds.....	1,113.5	724	3,228.5	3,016.75	6,565
Losses in first heat, pounds.....	3.5	1.25	3	3	157
Losses in second heat, pounds.....	3.25	1.50	2.75	4.5	141.5
Losses in third heat, pounds.....	.....	1.75	2.75	3	.....
Losses in fourth heat, pounds.....	.....	.....	3	3.25	.....
Losses in fifth heat, pounds.....	.....	.....	2	4.5	.....
Total losses per day, pounds.....	6.75	4.5	13.5	19.25	328.5
Fuel used in first heat, pounds or gallons.....	250	100	19.75	213	41.6
Fuel used in second heat, pounds or gallons.....	144	51	12.5	113	31.4
Fuel used in third heat, pounds or gallons.....	.....	53	11	107	.....
Fuel used in fourth heat, pounds or gallons.....	.....	.....	11	118	.....
Fuel used in fifth heat, pounds or gallons.....	.....	.....	7.75	730	.....
Total fuel used per day, pounds or gallons.....	394	203	62	681	73
Metal melted per pound or per gallon of fuel, pounds.....	2.8	3.1	52.1	4.43	90
Average time of first heat, minutes.....	181	132	120	106	.....
Average time of second heat, minutes.....	153	87	78	70	.....
Average time of third heat, minutes.....	.....	114	69	64	.....
Average time of fourth heat, minutes.....	.....	.....	72	70	.....
Average time of fifth heat, minutes.....	.....	.....	45	68	.....
Time taken to clean furnace, minutes.....	2	2	3	3	.....
Average metal per minute, pounds.....	3.04	2.17	5.4	7.97	15.63
Number of furnaces one furnaceman can attend.....	8	10	2	2	1
Metal produced, pounds.....	8,908	7,240	6,457	6,033	6,565

• 145,000 B. t. u. per gallon. • Furnace cold at start. • Furnace hot at start.

cooled to the proper color, it is cooled by plunging into oil.

The purpose of annealing steel is to soften it for machining, and also to remove all stress due to rolling or hammering. The temperature for annealing should be slightly above the critical point, which

varies with different steels. This temperature should be maintained just long enough to heat the entire piece evenly; care should be taken not to heat the steel much above the hardening point for when steel is heated above this temperature it becomes coarse. Overheated steel that is not actually burned can be partly restored by heating it to the proper temperature and allowing it to cool slowly in hot ashes or sand; after this process it must be hardened again at the proper tempering heat.

The presence of scale on the surface of hardened steel is due to oxidation when hot; consequently, to prevent scale the heated steel must not be exposed to the action of the air. When using an oven heating furnace, the flame should be so regulated that it is not visible in the heating chambers.



Operator on Modern Johnston Brass Furnace.

## CHAPTER XII.

### OIL IN THE STEEL INDUSTRY.

In the open hearth process of making steel the impurities in the pig iron are removed by the action of the flame upon an open bath of the molten metal. A very high temperature must be maintained in such a furnace to keep the iron thoroughly melted, and for this reason the air for combustion is heated to over 1000 deg. F. before it enters the combustion chamber. Measured quantities of ore, iron scale, or other oxides are added to the bath of molten metal, and these, reacting with the impurities present, serve to keep it thoroughly agitated. If the pig iron or scrap contains too much phosphorus, burnt lime is added to the charge, and the resulting slag absorbs the phosphorus.

There are many advantages in the use of oil as a fuel for open hearth furnaces. The cost of keeping such a furnace in repair is approximately 40 per cent less than when gas is used. The heat of the furnace is easily regulated, and a more even temperature may thus be maintained. Different chemical reactions take place in the furnace, producing a superior quality of castings; and a lower grade of scrap iron can be used with fuel oil than with producer gas. As a result of these advantages many large steel plants in the East have equipped their furnaces for the use of fuel oil. In localities where natural gas is abundant and coal is cheap, the oil installation is merely an auxiliary; it does not in any way interfere with the regular operation of the furnace with the other fuel, and is ready for use at a moment's notice.

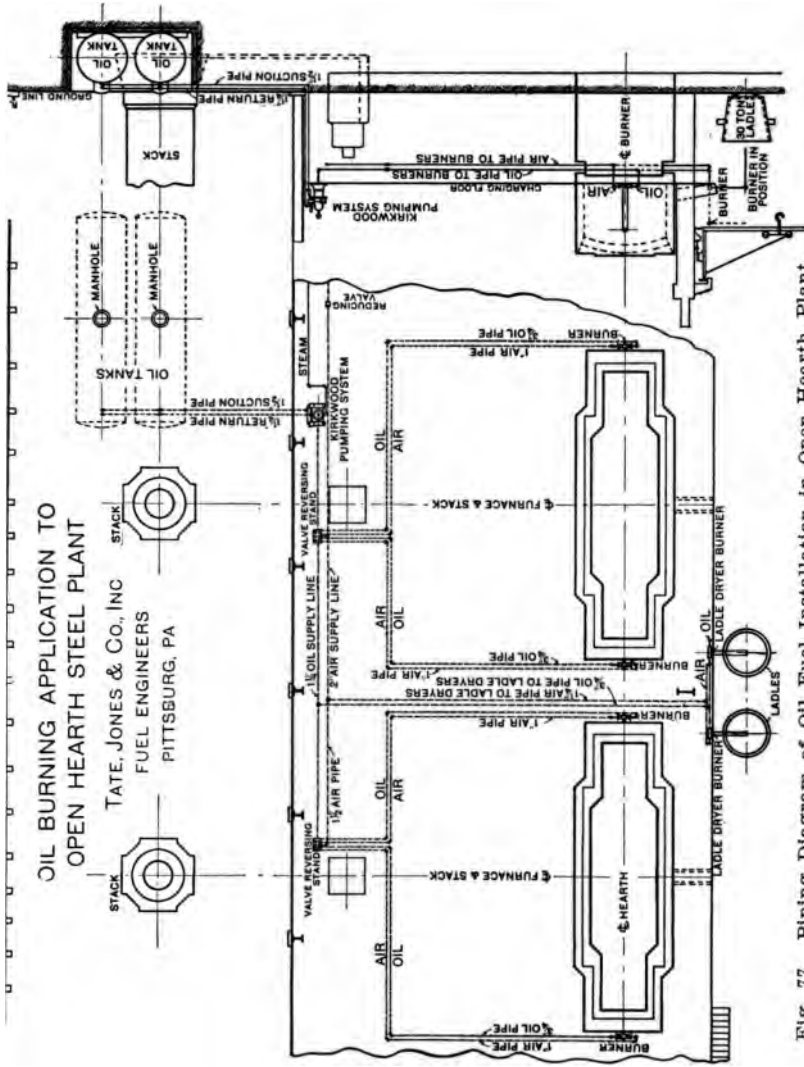

OIL BURNING APPLICATION TO  
OPEN HEARTH STEEL PLANT

TATE, JONES & CO., INC  
FUEL ENGINEERS  
PITTSBURGH, PA

Fig. 77. Piping Diagram of Oil Fuel Installation in Open Hearth Plant.

Open hearth furnaces may be very simply and inexpensively equipped to burn oil. Fig. 77 shows the general arrangement of piping, burners, pumping systems, reversing stand and storage tank for a plant

having two furnaces. The necessary apparatus for one open hearth furnace consists of two burners (one for each end of the furnace), a reversing stand located back on the charging floor for reversing the flow of the oil and the atomizing agent as the furnace is reversed, a pumping system for pumping oil from storage tank and heating and regulating the supply to the burners, a reducing valve for regulating the atomizing agent (air or steam) and the necessary valves, pipe, tank and fittings as shown. The reversing stand shown in Fig. 78 is used in the regenerating type of furnaces, in which the draft is changed at certain intervals from one side to the other, thus allowing the air



Fig. 78. Reversing Valve Stand.



pass through the regenerative chamber, which is made of checkered brickwork. The waste gases flow from one side of the furnace pass into this chamber and the brickwork absorbs a large part of the heat which they contain; by reversing the flow of the gases from one side to the other, the air for combustion comes in contact with these hot bricks and is preheated.

A swinging burner is commonly used for firing open hearth furnaces. When the furnaces are close together, or the end of the furnace is so near to the wall of the building that there is not room for the operation of a swinging burner, a water-cooled burner is used.



Fig. 79. Water-Cooled Burners Applied to Open Hearth Furnace.

Such a burner remains permanently in the furnace, both the burner and the water-cooled nozzle being swung in a yoke, so that the nozzle may be elevated or lowered as required. The circulation of water through a  $\frac{3}{4}$  in. pipe prevents

the burner from being melted off by the heat of the furnace.

Fig. 80 illustrates the application and use of the ladle drying burner. It is provided with a swinging stand and is located at a convenient place on the charging floor, or bolted against the columns of the building. It is arranged to lower into the ladle when in use, and to raise up when not in service. A long nozzle is provided for reaching well down into the bottom of the ladle so that the heat is evenly distributed over the bottom and up the sides. A sheet iron cover is



Fig. 80. Ladle-Drying and Heating Oil Burner.

put over the ladle to protect the burner and retain the heat and help to distribute it to the sides of the ladle.

Some plants making merchant bar iron from scrap, use a furnace in which the waste heat is utilized by the installation of a boiler at the end of the furnace. Data secured at one plant using this arrangement show the consumption of oil per ton of iron to

be 47 gal. The waste heat secured from the two furnaces was sufficient to furnish the necessary steam for operating the engines driving the rolls, pumping water and generating the electricity and steam used throughout the plant.

The report below was received from a rolling mill in which fuel oil has been used for many years. The manager states that the quality of iron produced from the scrap material is much better with oil than with coal as a fuel. When running through the rolls, the percentage of weight lost is much lower, as the metal is better able to withstand the compression, vibratory and torsional stresses of the rollers. The same size of furnace with coal fuel would only handle from 30 to 32 tons of material daily; and the expense of upkeep is about 35 per cent less than with coal. Various atomizing agents have been tried, including steam, high pressure air, and steam and low pressure air combined; but it has been found that much better results are obtained from low pressure air.

#### Report on Furnace at Rolling Mill.

Capacity of furnace.....	40 tons
Type of burner.....	Low pressure air
Pressure of air.....	10 ounces
Pressure of oil.....	20 lbs.
Temperature of oil.....	110° F.
Time required to heat furnace.....	1 hour
Oil required to heat furnace.....	40 gals.
Time required to heat one ton of metal.....	36 minutes
Oil required to heat one ton of metal.....	35 2-10 gals.
Oil consumed per 24 hours.....	1,408 gals.
Metal treated in 24 hours.....	40 tons
Heat units of oil.....	18,500 B.t.u.

Fig. 75. Riverall Furnace for Smelting With Oil.

#### Pacific Coast Plant.

Size of furnace .....	25 tons
Duration of run.....	24 hrs.
Atomizing agent .....	steam
Steam pressure .....	60 lbs.
Oil pressure .....	45 lbs.
Oil temperature .....	85° F.
Total oil consumed.....	27 bbls.
Total weight of charge .....	27 tons.
Gallons of oil per ton.....	42 gals.
Heat units of oil.....	18,500 B.t.u.



Fig. 81. Showing Open-hearth Furnace of Twenty-Two Capacity at the West Coast

Iron Works, where the Jarvis Swinging Jet Burner is installed.

**Southern Plant.**

Size of furnace .....	30 tons
Duration of run .....	24 hrs.
Atomizing agent .....	air
Air pressure .....	25 lbs.
Oil pressure .....	25 lbs.
Temperature of oil .....	78° F.
Total oil consumed .....	1255.5 gals.
Total weight of charge.....	31 tons
Gallons of oil per ton.....	40.5 gals.
Heat units of oil.....	18,650 B.t.u.

**St. Louis Plant.**

Size of furnace .....	40 tons
Duration of run .....	24 hrs.
Atomizing agent .....	air
Air pressure .....	30 lbs.
Oil pressure .....	35 lbs.
Temperature of oil.....	120° F.
Total oil consumed.....	1661.75 gals.
Total weight of charge .....	42½ tons
Gallons of oil per ton.....	39.1 gals.
Heat units of oil.....	18,740 B.t.u.

It will be noticed that there is a difference of about three gallons of oil per ton of steel between the Pacific Coast and the St. Louis plant. While the oil used by the St. Louis plant has a slightly greater heating value, it is not sufficient to warrant the difference in consumption. The type of burners used being much the same, the larger furnace is evidently more economical than the smaller one.

The value of a pyrometer in the open hearth furnace is well illustrated by the following data, taken while making semi-mild steel:

Temperature of furnace.....	2,876° F.
Temperature of gases at chamber.....	1,832° F.
Temperature of gases at stack.....	540° F.
Temperature of atmosphere.....	70° F.
Temperature of air entering furnace.....	700° F.
Temperature of molten steel in ladle.....	2,902° F.
Heat units in the oil.....	18,840 B.t.u.
Oil per ton of metal.....	42 gals.

From these data the heat balance can be computed; that is, the consumption of heat units may be itemized to determine where the losses are taking place, and to show the economy obtained by preheating the air for combustion.

Analysis of oil:     q

C-85.6	Sulphur gravity.....	.9395
H-11.89	Weight per gallon.....	7.83
O-0.9	B.t.u. ....	18,840
N-.52		
S-1.09		

From table on oxygen and air required for combustion:

Carbon  $.856 \times 2.667 = 2.283$  lb. oxygen needed.

Hydrogen  $(.1189 - \frac{.009}{8}) \times 8 = .942$

Sulphur  $.0109 \times 1 = \frac{.01}{3.236}$  lb. oxygen needed.

As one pound of oxygen is contained in 4.32 pounds of air, the total air required per pound of combustible is  $3.236 \times 4.32 = 13.98$  lb.

The weight of combustible per pound of fuel is:  $.856 + .1189 + .0109 = .986$ , and the theoretical amount of air is 13.98 divided by  $.986 = 14.18$  lbs.  $\times 12.39 = 175$  cu. ft. of air per pound of fuel. One barrel of oil weighs  $328.86 \times 175 = 57,500$  cu. ft. of air per barrel. Specific heat of air  $= .0189 (T^1 - T) + .0000009 (T^2 - t^2)$ .

Heat in air  $= 57,500 (.0189(700 - 70) + .0000009(490000 - 4900)) = 709,500$  B.t.u. heat entering furnace with the air per barrel of oil. The per cent gained by preheating the air to 700° F. is shown as follows:

$328.86 \times 18840 = 6,195,722$  B.t.u. per barrel of oil.

Then  $\frac{709,500}{6,195,722} \times 100 = 11.45\%$  heat gained by pre-

heating the air.

B.t.u. required to heat furnace to 2876° F.  $= 57,500 (.0189(2876 - 700) + .0000009(8271376 - 490000)) = 2,760,000$  B.t.u.

B.t.u. absorbed by one ton of charge  $= 2240 \times (.0189(2876 - 700) + .0000009(8271376 - 4900)) = 137,000$  B.t.u.

Loss due to heat carried away by steam formed by the burning of hydrogen  $= 9 \times .1189(212 - 70) + 970.4 + .48(1832 - 212) = 2020 \times 328.86 - 665,000$  B.t.u.

Loss due to escaping gases at stack= $14.18 \times .24$   
 $(540-70)=1600 \times 328.86=526,500$  B.t.u.

As 42 gallons of oil were consumed per ton of metal we have:

	Per cent.	B.t.u. per bbl. oil.
Heat absorbed by furnace.....	44.7	2,760,000
Heat absorbed by charge.....	2.22	137,000
Loss due to heat carried away by steam formed by the burning of hydrogen....	10.75	665,000
Loss due to heat carried away in dry chimney gases .....	8.5	526,500
Losses due to radiation.....	33.83	2,107,000
<b>Total .....</b>	<b>100.00</b>	<b>6,196,000</b>
Heat gained by preheating air.....	11	709,500
Actual heat loss by radiation.....	27.9	1,397,000
Per cent of radiation losses recovered by pre- heating air in chamber.....	33.6	

It is interesting to note the small percentage of heat absorbed by the charge. The amount of latent heat of fusion or the heat absorbed by the charge during the process of changing to a fluid is very small, being about 45 B.t.u. per pound or 56,000 B.t.u. per ton. The furnace was probably heated a few degrees more than was absolutely necessary, but the charge was not thoroughly melted until a temperature of 2720 was reached. The heat losses due to radiation are rather high, but it is hard to determine just where they take place on account of the high temperature of the gases leaving the furnace. We have ascertained that 33.6 of these losses have been recovered, due to the preheating of the air for combustion in the regenerative chambers. The amount recovered could probably be increased by rearranging the checker brick in the regenerative chambers, as many open-hearth kilns have the preheated air at a much higher temperature.

The following formula may be used to determine the maximum available horsepower that may be secured from the waste furnace gases:

$$\text{H.P.} = \frac{W (T - t) \times S + 777.5}{1,980,000}$$

where  $W$  = the weight of gases passing per hour, in pounds

$T$  = temperature of gases entering the heating surface.

$t$  = temperature of gases entering the heating surface.

$S$  = specific heat in gases.

Fig. 82 illustrates a home-made crucible furnace. This furnace holds from five to six crucibles containing 150 lb. per pot, and a furnace temperature of 3500° F. maintained on a consumption of 10 gal. of oil per hour. The air for combustion is supplied by a No. 4 blower; the pressure of oil at the burner is 20 lb. and the pressure of the air used as an atomizing agent is 20 lb.

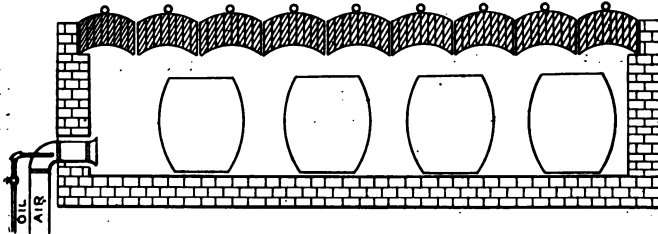

Fig. 82. Crucible Steel Furnace.

The consumption of oil in billet-heating furnaces varies with the size of the furnace. Some require as much as 21 gal. of oil per ton of steel, while one report shows a large continuous billet furnace operating on 14 2/10 gal. per ton of steel and heating 360 tons per day of 24 hours. Great care must be taken in the heating of steel before rolling, for the strength and ductility depend to a large extent upon fineness of the grain and this may be obtained only by having the temperature of the steel rather low during the finishing stage of rolling 1300° to 1400° F., or a dull red heat, giving the best results.



## CHAPTER XIII.

### FUEL OIL FOR NAVAL AND MARITIME PURPOSES.

The supply of a fuel is one of the most important problems with which the navies and steamship companies of the world have had to deal. That fuel oil has practically solved this problem is clearly indicated by the number of vessels at present in use in which oil is the principal or only fuel.

A method of using oil at sea was successfully worked out over 40 years ago by the marine engineers on the Caspian Sea. The process used was most carefully kept secret as the shipowners considered it a most valuable asset. Thus when large quantities of oil were discovered in Texas and California, it remained for the engineers in those localities to work out the problem for themselves. The success they achieved is indicated by the economies effected, the high evaporative results obtained and the reports showing an engine horsepower produced on one pound of oil or less. Exhaustive tests were conducted some years ago by the naval engineers, in order to determine the most practical method of using fuel oil, and of storing oil in vessels. As a result of these tests, which were carried out by the U. S. Naval "Liquid Fuel" Board, under the direction of Rear Admiral George W. Melville, some of the newest battleships have been equipped to use fuel oil exclusively, while others are so arranged that both coal and oil may be burnt at the same time, or either fuel can be burnt separately.

The first part of the document discusses the general situation of the country and the measures taken to improve the economy. It mentions the need for a more efficient system of production and distribution, and the importance of increasing the productivity of the labor force. The document also talks about the need for a more modern infrastructure, including roads, bridges, and communication systems. It emphasizes the role of the government in planning and coordinating these efforts.

The second part of the document details the specific measures being implemented. It includes a list of projects and programs, such as the construction of new factories, the expansion of existing ones, and the development of new technologies. It also discusses the need for a more skilled workforce and the importance of investing in education and training. The document mentions the need for a more efficient system of transportation and communication, and the importance of improving the quality of life for the population.

The third part of the document discusses the future prospects of the country and the role of the government in achieving these goals. It mentions the need for a more stable political environment and the importance of maintaining good relations with other countries. It also discusses the need for a more efficient system of government and the importance of increasing the transparency and accountability of the public sector. The document concludes with a statement of confidence in the future of the country and the commitment of the government to achieving these goals.

These gave very satisfactory results, but were costly to install and operate. Probably, the most satisfactory method that has been invented is the mechanical system of atomizing. This was first brought to the writer's attention in 1907, when an installation known as the "Meyers Liquid Fuel Burner," was invented on the S. S. Romany, an oil tanker of 1600 i.h.p. The results of the first test show that an i.h.p. was developed by 1.21 lb. of oil. Prof. E. H. Peabody stated, in a paper read before the Society of Naval Architects and Marine Engineers in New York, Nov. 22, 1912, that "the mechanical atomizer," so called, is understood to mean a device which sprays or atomizes oil or other liquids by pressure alone, without the use

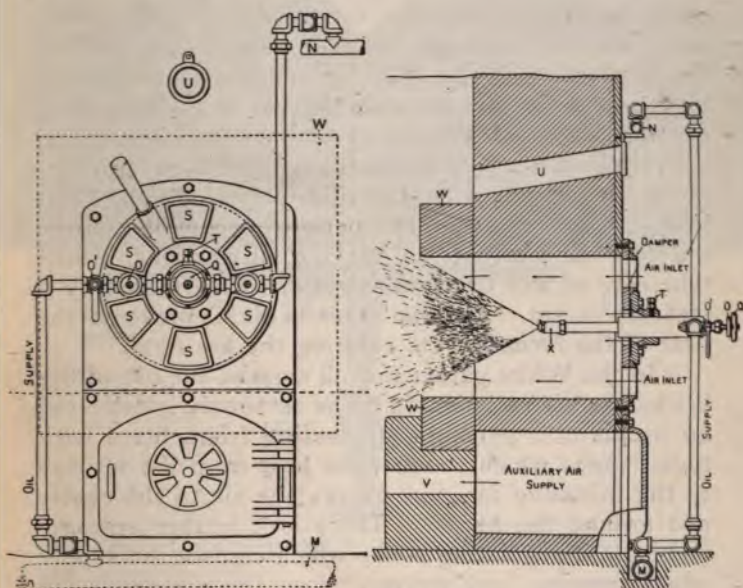

Fig. 83. Front View and Sectional Elevation of Spray Burner.

of compressed air, steam or other exterior atomizing agents. He also calls attention to the fact that no mechanical atomizer produces a revolving spray, but states that the particles of oil fly off in straight lines

under the influence of centrifugal force, thus forming a hollow conical spray.

A number of burners operating on this system are illustrated herewith. Fig. 83 shows a front and sectional elevation of the Spray Engineering Company's oil burner installation as applied to the average boiler. Fig. 84 shows the Coen Mechanical system, in which air is pre-heated by passing under the bottom of the furnace. In the design of the furnace, Mr. Coen paid particular attention to the following important features: first, the uniform distribution of heat in the fire-box; second, uniform admission of air for combustion; third, control of the direction and volume of this air; and fourth, the avoidance of heat losses due to radiation from the furnace to the fire-room. By referring to the figure, one can readily see how well these points have been covered. The distribution of the heat is absolutely uniform and the diameter and length of the flame from the burner is under perfect control. Two different and distinct supplies of air are provided for, each individually controlled; primary air is admitted at A, and auxiliary air at B. The flexibility of this arrangement permits a combination of different air currents in varying proportions, which take care of any draught conditions experienced by a steamer at sea. The radiation baffle C prevents the heat of the furnace from entering the fire room.

In the White patent fuel oil system, the use of fire bricks has been eliminated. The air supply is delivered by means of a patented air heating front, fitted with radial vanes which conduct the heat from the furnace to the incoming air, and convey the air to the center and around the burner. There is a further arrangement of air-regulating cones which control the supply when running, and entirely close the air admission when not burning oil. A sliding cone regulates the length and spread of the flame. This system of regulating cones permits complete control of the air admitted to the furnace, thus insuring perfect mixtures of air and oil. No air can pass through the furnace without coming into contact with the flame.

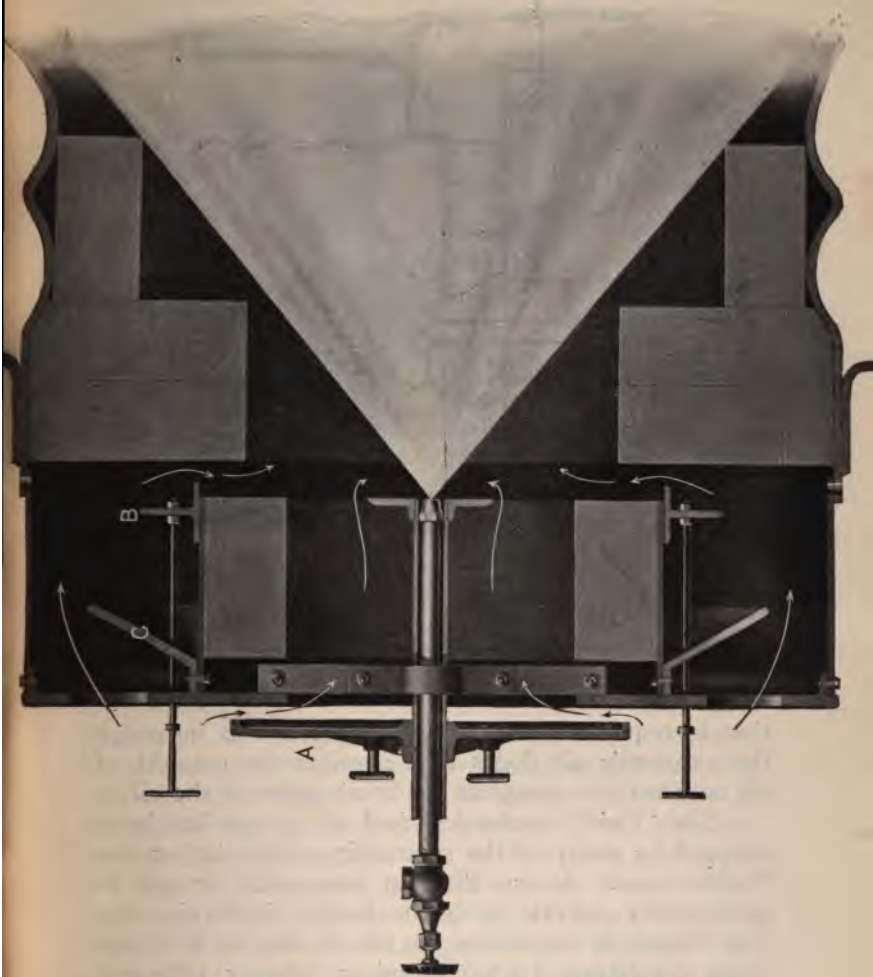

and complete combustion is obtained when the cones are correctly set.

The Koerting system is the outcome of a number of experiments conducted by Schutte-Koerting Company of Philadelphia, Pa. Fig. 87 shows a sectional view of boiler fronts with the Koerting system applied to a water tube boiler. C is the air register, fitted with air admission slides to regulate the air

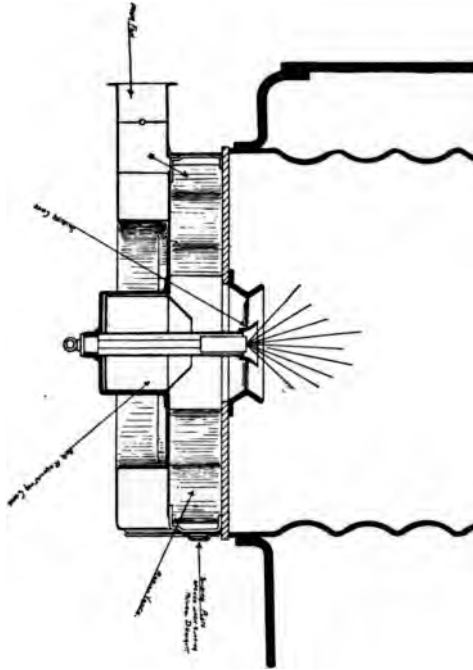

Fig. 85. Arrangement of Furnace for Forced Draught with White Patent Burner.

that is required around the burner; and B indicates the automatic air doors that regulate the amount of air necessary to complete the combustion of the oil.

The "Dahl" mechanical fuel oil system has been adopted by many of the steamship companies on the Pacific Coast. It was the first mechanical system to successfully operate with the heavy California oils. The burner is extremely simple, having only a few parts, consisting of a tip, atomizer, strainer, tube and valve. The operation of the burners is regulated by the pressure on the oil line, rather than the valve of the burner.

The furnace front as shown in Fig. 89 is of approved construction, so arranged that the burner passed through a pipe, on the end of which is a cone or deflector which can be adjusted by moving it in or out to insure the proper quantity of air just where

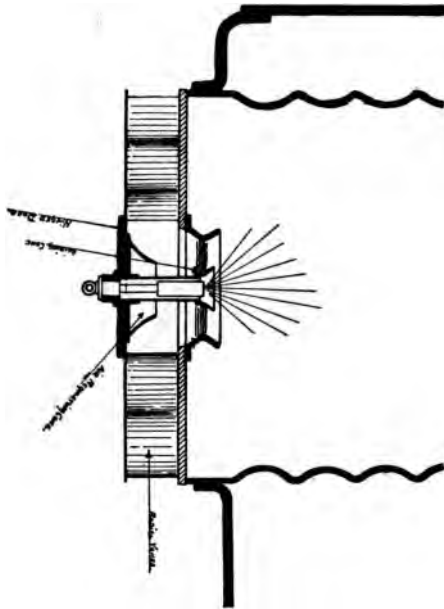

Fig. 86. Arrangement of Furnace for Natural Draught with White Patent Burner.

it is needed. The front is extended so that the whole length of the furnace is utilized, and the brickwork is so fitted that repairs and examinations can be made without removing it. Fig. 88 shows an outline of an installation on a Scotch marine boiler, arrangements of pumps, heaters, etc., being clearly indicated.

Fig. 91 illustrates the Tate-Jones pressure jet burner and furnace front. The oil is fed to the burner at 125 to 200 lb. pressure, and passes through tangential slots in the burner tip, where it attains a high velocity of rotation in the vortex chamber, and escapes through the opening in the end of the burner as a fine mist in the shape of a hollow cone.

The amount of air needed for combustion is regulated by the damper on the air cone of the furnace front. The range of regulation is sufficient to make it adaptable for either natural or force draft. Inside the air cone are fixed the air impellers or blades, which

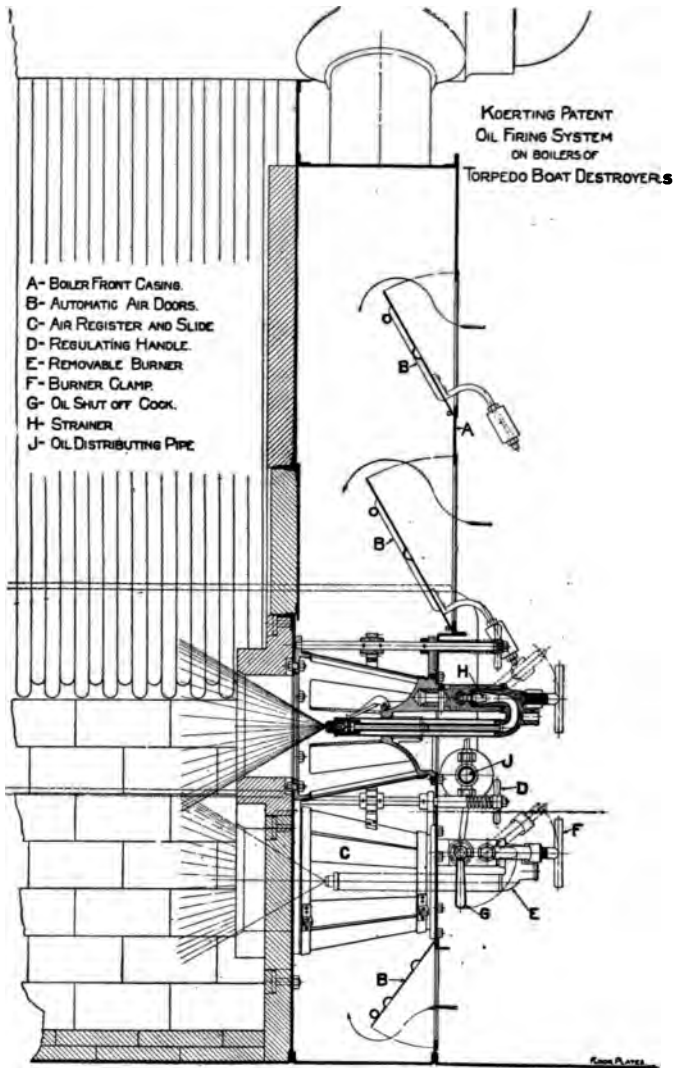

Fig. 87. Koerting Oil Firing System.

give a rotary or whirling motion to the entering air. This whirling motion mixes the entering air with the oil mist much better than when the air enters in straight lines.



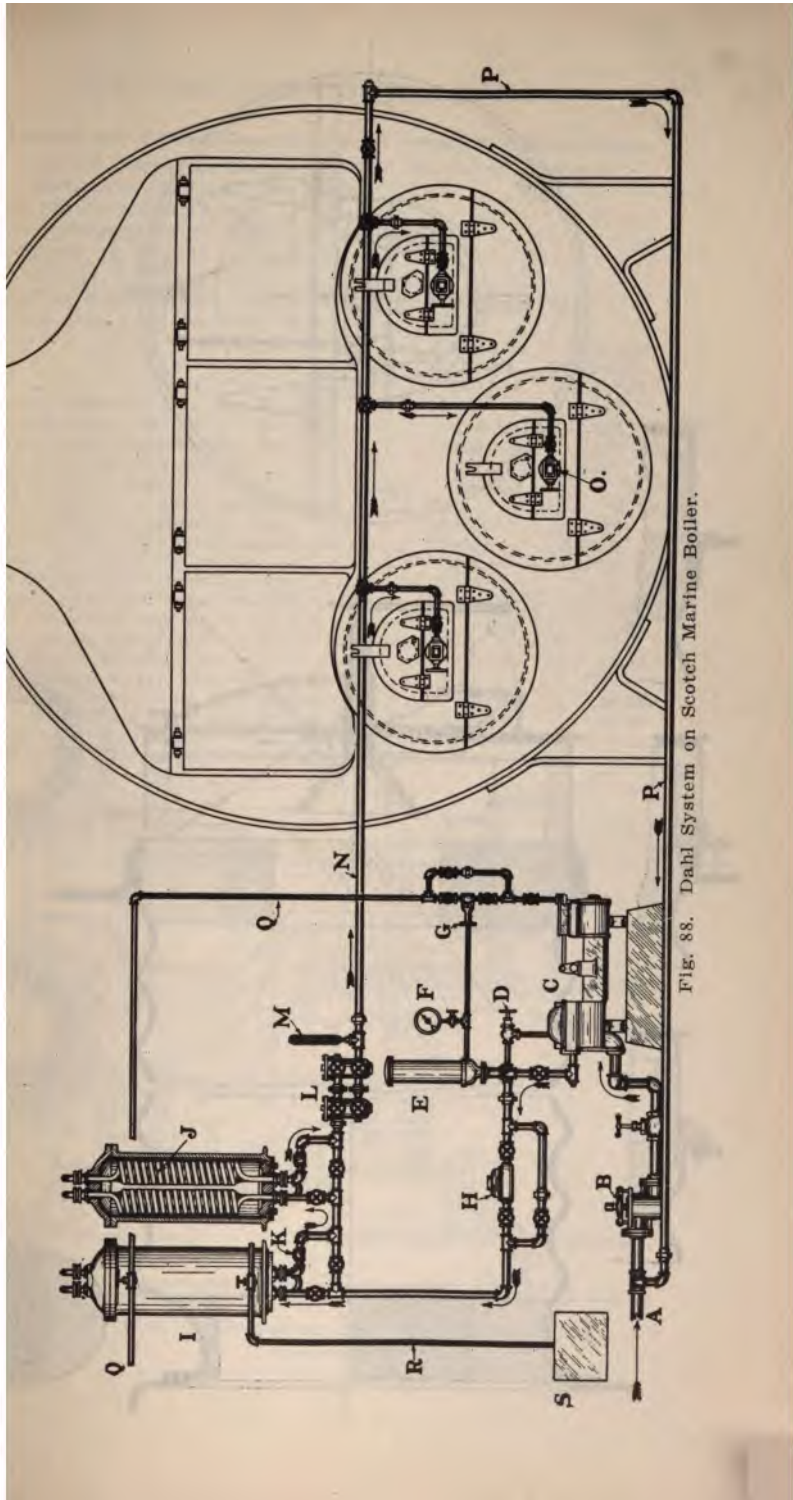
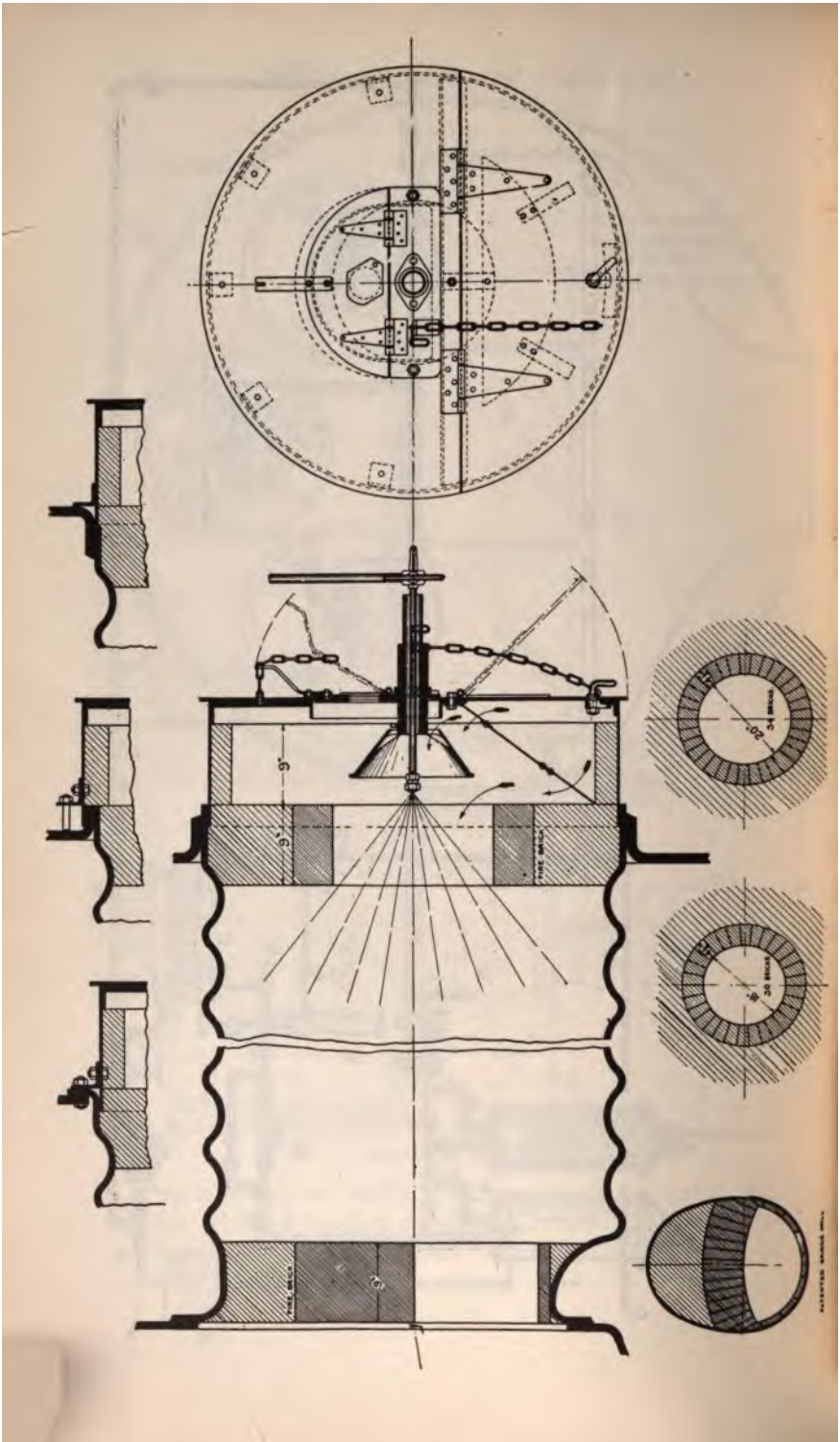

Fig. 88. Dahl System on Scotch Marine Boiler.



**Natural and Forced Draft Test for Comparative Evaporation.**

(Scotch Marine Boiler Fitted With Oil Burning System.)  
 Remarks—Data for One Boiler.

One Scotch Marine Boiler.  
 Three Corrugated Furnaces—38 in. I. D.  
 Diameter, 13 ft. 10 in. Length, 9 ft. 10 in.  
 Pressure, 150 lbs. W. P.  
 Heating Surface, 1658 square ft.  
 Tubes—250, 3 in. diameter, 6 ft. 9½ in. long.

	Natural Draft, 4.75 hrs.	Forced Draft, 4 hrs.
Steam pressure, lbs. per sq. in.....	143	140
Oil pressure, lbs. per sq. in.....	144	144
Feed water temperature, deg. F.....	139	135
Oil temperature, deg. F.....	231	223
Stack draft, inches .....	%	%
Air pressure in duct, inches.....		5/16
Total water evaporated, lbs.....	66,300	57,580
Pounds of water evaporated, per hr...	13,958	14,395
Total oil consumption, lbs. ....	5,035	4,315
Oil consumption, per hr., lbs.....	1,060	1,079
Water evap. per 1 sq. ft. H.S. per hr...	8.418	8.682
Oil consumed, per sq. ft. of H.S. per hr.	0.639	0.65
Pounds of water per lb. of oil per hr., actual evaporation .....	13.16	13.34
Pounds of water evaporated per lb. of oil per hr. from and at 212 deg. F.	14.76	15.03.
oil per hr. from and at 212 deg. F.	14.76	15.03
Increased evaporation, forced over natural draft, 3.13 per cent.		
Increased oil economy, forced over natural draft, 1.33 per cent.		

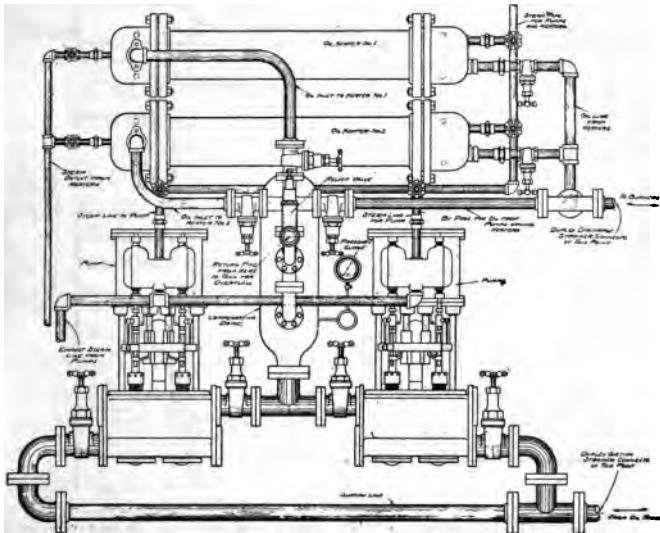

Fig. 90. Fuel Oil Pumping, Heating and Regulating System.

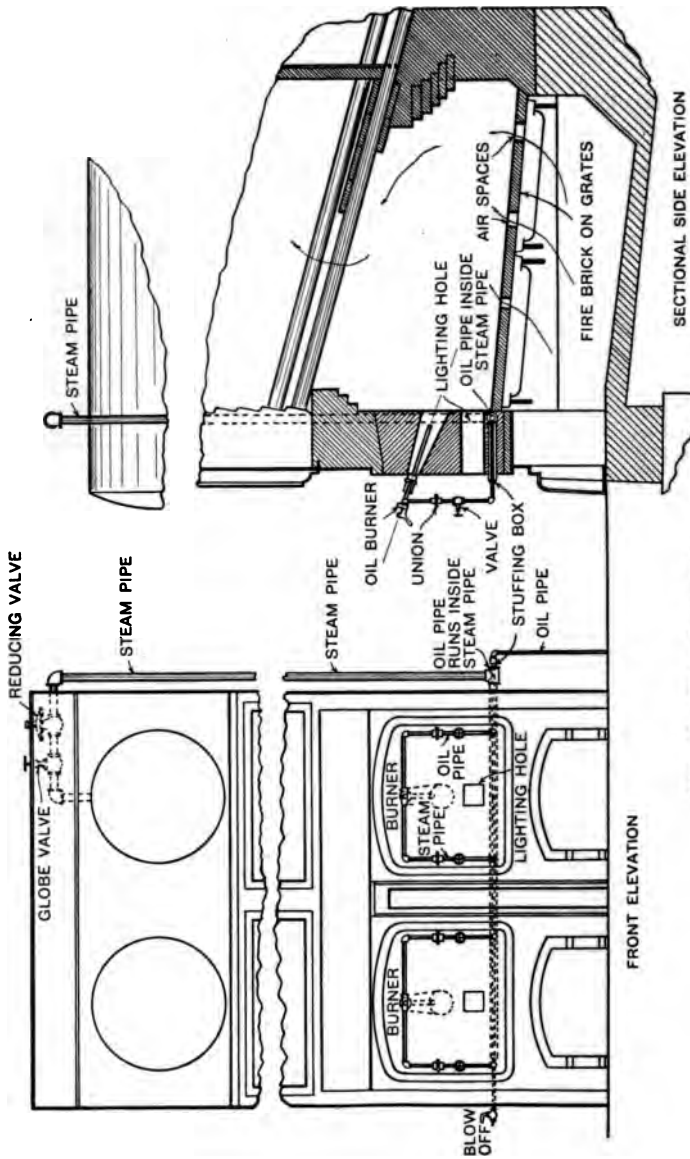

Fig. 91. Tate-Jones Pressure Jet Burner

Fig. 90 illustrates the fuel pumping, heating and regulating system, which is in duplicate throughout

Most types of mechanical atomizers will produce a fine spray of oil; the important problem is to secure a furnace design and arrangement which will insure proper distribution of the air. A test was recently conducted on the steam yacht "Idalia." This vessel is fitted with a Babcock & Wilcox marine boiler, containing 2560 sq. ft. of heating surface. A simple and effective system of induced draft fans was installed, capable of giving a suction in the uptake of 1 to 1¼ in. of water, and in addition to this a forced draft fan was set up on the dock and connected by means of a flexible duct to a sheet casing enclosing the oil burners in front of the boiler. The tanks and scales for weighing the oil and water and the oil pump and heater were set up on the dock and connected to the vessel by means of flexible pipes, the regular feed pump of the plant being used for taking weighed water from the filter box. The engines and other auxiliaries were not in use, the steam discharged to the atmosphere through a muffler arranged to maintain regular working pressures on the boiler. All precautions were taken to prevent leaks and secure accurate data. Fifteen evaporative tests were made, under a variety of conditions, the results being given in the table below. Between these tests, considering experimenting was done with various air-distributing arrangements, flat burners, etc. The best performance was an evaporation of 7.47 lb. of water per square foot of heating surface per hour from and at 212 degrees, F., at an efficiency of 82.8 per cent at a rate of combustion of 6.17 lb. of oil per cu. ft. of furnace volume per hour with a draft in the uptake of .84 in. of water

Other tests were made on the United States battleship Wyoming with coal as fuel, oil as fuel, and a combination of coal and oil. The oil was sprayed over the coal fire, a flat flame being secured by adjusting the admission of air. The capacity of the boilers can be increased by using oil in this manner, but efficient results are obtained only when either fuel is used alone.

Observations.	Idalia Tests.			
	Oct. 30	Oct. 29	Nov. 5	Nov. 10
Duration of test in hours.....	3	3.5	3	1
Steam pressure in pounds.....	228	225	223	222
Temperature of feed water (F.).....	60	98	98	52
Superheat in steam (F.).....	31	30	44	71
Pressure of oil at burners.....	239	228	222	47
Temperature of oil at burners.....	190	206	195	222
Oil burnt per hour (lbs.).....	749	794	782	198
Oil per burner per hour.....	187.2	176.1	1,802	214
Oil per cubic foot of furnace volume per hour.....	5.31	8.74	195.4	300.5
Oil per square foot heating surface per hour.....	.292	.275	4.15	6.38
Draft in uptake (in.).....	-.43	-.39	-.72	.470
Draft in furnace (in.).....	-.18	-.17	-.86	.449
Blast at burners (in.).....	.00	.00	.00	.94
Temperature of air (fireroom).....	86	101	71	88
Temperature of waste gases.....	504	546	550	88
Analysis of waste gases—%.....	13.2	10.2	8.2	654
CO <sub>2</sub> .....	8.0	6.5	8.2	689
CO.....	0.0	0.0	0.0	9.4
N.....	83.8	84.3	83.5	7.8
Water evaporated from and at 212 degrees (F.)....	11,502	10,806	9889	8.2
Water per sq. ft. heating surface from and at 212° F..	4.49	4.22	3.73	8.8
Water per lb. oil from and at 212 (F.) in lbs.....	15.36	15.4	12.65	8.2
Specific gravity of oil.....	.934	.934	.934	0.0
Flash point of oil (F.).....	220	220	220	trace
B.t.u. per lb. of oil.....	19,021	19,021	19,021	83.5
Efficiency, per cent.....	78.0	77.8	64.2	82.8
.....				16,137
.....				16,225
.....				6.34
.....				14.11
.....				16,225
.....				6.45
.....				16.45
.....				7.45
.....				19,174
.....				80.1
.....				82.8

The above tests were made under a Babcock & Wilcox boiler with superheater H. S. 2,560; S. H. S. 340; Peabody mechanical burners; Texas oil.

The following report was taken recently from the S. S. Tento Maru :

Number of boilers .....	13
Style of boiler—single ended Scotch Marine.	
Number of furnaces—four in each boiler.	
Total number of furnaces.....	52
Diameter of furnaces .....	40½ in.
Length of furnace.....	7 ft.
Thickness of furnace.....	9/16 in.
Total number of plain tubes, all boilers....	4264
Total number of plain stay tubes, all boilers	2336
Diameter of tubes, plain and stay.....	2½ in.
Length of tubes, all.....	7 ft.
Thickness of tubes, plain.....	No. 10 B.W.G.
Thickness of tubes, stay.....	No. 8 B.W.G.
Heating surface per boiler.....	2,897 sq. ft.
Total heating surface of all 13 boilers.....	37,661 sq. ft.
Steam pressure allowed.....	180 lb.
Oil pressure carried.....	15 to 20 lb.
Oil temperature ordinarily.....	170 in. to 180 deg.
Oil used per day at sea, under one boiler..	15 tons
Total oil capacity.....	2,500 tons
Temperature of feed water.....	200 deg.
Size of oil pump.....	4½ x 6 x 6
Style of oil pump, duplex, Washington.	
Number of oil pumps .....	2
Temperature of stack.....	500 deg.
Temperature of fire room.....	100 deg.
Style of engines, Parsons Turbine.	
Number of engines, 1 high and 2 low pressure.	
Size of oil heater, about 30 in. in diam., 24 in. high.	
I. H. P. of main engines, maximum.....	19,000 h.p.
I. H. P. of main engines, ordinary running..	12,000 h.p.
I. H. P. of auxiliary machinery.....	500 h.p.
Speed, maximum .....	20 knots
Speed, maximum, ordinary run.....	15 knots
R.P.M., maximum running.....	300 r.p.m.
R.P.M., ordinary running.....	200 r.p.m.
15 tons of oil used per boiler in 24 hr.	
6 boilers in use for oil.	
$15 \times 6 = 90$ tons of oil used by 6 boilers in 24 hr.	
$90 \times 2,000 = 180,000$ lb. of oil used by 6 boilers in 24 hr.	
$180,000 \div 7,500$ lb. of oil used in 1 hr.	
12,000 I. H. P. total for 12 boilers.	
6,000 I. H. P. total for 6 boilers.	
500 I. H. P. total for auxiliaries for 12 boilers.	
250 I. H. P. total for auxiliaries for 6 boilers.	
$6,000 + 250 = 6,250$ total I. H. P. for 6 boilers.	
$7,500 \div 6,250 = 1.2$ lb. of oil per I. H. P.	

They operate six boilers with coal and six boilers with oil on the run between San Francisco, Cal., and Yokohama, Japan; and the twelve boilers with coal between Yokohama and Hongkong, or about thirty days using oil under six boilers and coal under the other six boilers, and ten days using coal under all twelve boilers.

In order to determine the available cargo space gained by this method let us assume the following data:

Ninety tons of oil used each 24 hr., and at the rate of 30 steaming days, 2700 tons of oil is consumed. The equivalent amount of coal would be, taking the oil at 15 deg. B. or 6.65 bbl. of oil the ton = 17,955 bbl. of oil and four bbl. of oil being equivalent to one ton of coal would make 4489 tons of coal. Figuring coal at 42 cu. ft. to the ton would give a total of 188,538 cu. ft., figuring on ship's measurements, 40 cu. ft. to the ton would give us 4463 tons available for cargo space.

In many instances ship owners could use oil to advantage, providing they use the ballast or water bottoms to store the fuel oil.

Even large oil carrying steamers are using oil fuel on the outward voyage, owing to the difference in the price of the fuel. Fuel oil is carried in bulk in specially constructed tank steamers. The tanks being so designed as to be able to carry oil, or can be cleaned to carry cargo.

U. S. regulations for the installation of fuel-oil petroleum for the production of motive power on ocean and coastwise steam vessels:

On all ocean and coastwise steam vessels burning oil, as fuel for the production of motive power, the fuel-oil tanks including settling tanks shall be constructed of iron or steel plates of not less than five-sixteenths inch in thickness, when such tanks are built separate from the hull, and shall withstand a pressure of 15 lb. per sq. in.: Provided, however, that where the oil is carried in water bottoms or deep tanks constructed as part of the hull, the same shall be tested to a 30 ft. head.

In all tanks built separate from the hull, the rivet holes shall be fairly drilled, and in no case punched and reamed; the rivets shall be spaced four diameters of the rivet from center to center; the seams shall be double chain riveted; the edges of the seams shall be calked inside and out, and the burrs shall be removed from the sheets before riveting.



On ocean and coastwise steamers all pipes over 2 in. in diameter shall be flanged where attached to tanks. The filling pipes on tanks shall run through the top of tank and be carried to the bottom with a U bend extending upward at least 12 in. above the bottom to prevent filling pipe from clogging, to expel gases in the tank through the vent pipes when tanks are being filled. The area of the vent pipes shall be not less than the area of the filling pipe, and shall be carried over the upper deck or superstructure to the atmosphere and have non-return U bends properly fitted with wire gauze. Where bends or turns are necessary to carry this pipe, they shall be made with bends or 45 deg. elbows. Where there are a number of vents connected with the vent box, box shall be covered with wire gauze.

No openings shall be cut in the bottom, ends, or sides of tanks, unless for suction, and when such holes are cut in the bottom or sides of tanks an internal gate valve shall be placed inside the tank, connected by a rod leading through the top of the tank with a stuffing box attached thereto, and a wheel or handle for shutting off same from the top, which shall be accessibly placed so valve may be shut immediately at all times.

The valves on all tanks shall be so arranged as to be accessible at all times, and when placed on tanks in the double bottoms under the cargo hold they shall have rods connected thereto carried to the deck in accessible places.

All pipes and connections between feed pumps and burners on all high pressure systems shall withstand may be made with flanges or screwed fittings.

a pressure of 500 lb., and all connections in pipe lines

When heaters are used, the joints shall be made on the outside of the heater. A continuous pipe or pipes shall be carried through the heads or ends of the heater, and all joints shall be made on the outside to prevent oil getting into the boiler: Provided, however, that this construction is not necessary when the steam from the heater does not exhaust into the main condenser

On ocean or coastwise wooden vessels, where oil tanks are set in the vessel, lead lining shall be placed underneath the tanks, having a weight of not less than 8 lb. per sq. ft., to prevent any oil from getting into the bilges of the vessel. No bulkheads shall be required around oil tanks, except the water-tight bulkheads required by law.

The throttle valve on the pumps shall be arranged to be closed from the fireroom, or from some accessible place either outside the room where the pumps are located, the engine rooms or the deck above the boiler rooms, the location of these rods to be designated by the inspector in whose district the installation is made.

On all vessels of over 500 gross tons there shall be in each fireroom a metal tank containing 50 gallons of sand fitted with a scoop or shaker for fire purposes; also two or more approved fire extinguishers placed accessible to the fireroom and ready for immediate use: Provided, however, that steamers of 500 gross tons and under may be fitted with metal tanks containing 25 gallons of sand.

Cofferdams may be used when required by classification or any standard bureau of construction, but same are not compulsory under these regulations.

When expansion trunks extend above the decks, all rivet holes shall be drilled and double chain riveted.

Lloyds rules for the burning and caring of oil fuel:

1. On vessels fitted for burning oil fuel, and having the society's classification, the following records will be made in the register book: "Fitted for oil fuel F. P. above 150 deg. F." in cases in which approval has been given for the use of high flash point oil only; and "Fitted for low flash oil fuel" in cases in which the approval covers the use of oil with low flash point.

2. The following arrangements are applicable only to the case of oil fuel, the flash point of which, as determined by Abel's close test, does not fall below 150 deg. F. For oil fuel with a lower flash point the arrangements must be submitted for special consideration.

3. Oil fuel, the flash point of which by Abel's close does not fall below 150 deg. F., may be carried in ordinary cellular double bottoms either under engines or boilers or under ordinary cargo holds, also in peak tanks or in deep tanks; or in bunkers specially constructed for the purpose.

4. Cellular double bottoms when fitted for oil fuel are to have oil tight center line divisions, and the lengths of these compartments are to be submitted for approval.

5. Peak tanks, deep tanks, bunkers specially constructed for oil fuel, and settling and other service tanks must be fitted with bulkhead sub-divisions or wash plates to the committee's satisfaction and be strengthened so as to efficiently withstand the stresses brought upon them when only partly filled and in a seaway. The riveting of these spaces is to be as required by the rules in the cases of vessels carrying petroleum in bulk and scantlings and arrangements must be to the committee's satisfaction.

6. All compartments intended for carrying oil fuel must be tested by a head of water extending to the highest point of the filling pipes or 12 ft. above the load line, or 12 ft. above the highest point of the compartment which ever of these is the greatest.

7. Each compartment must be fitted with an air pipe to be always open, discharging above the upper deck. It is recommended that all double bottom compartments used for oil fuel should have suitable holes and doors of approved design fitted in the outer bottom plating.

8. Efficient means must be provided by wells or gutterways, and sparring or lining, to prevent any leakage from any of the oil fuel compartments from coming into contact with cargo or coal, and to ensure that any leakage shall have free drainage into the limbers or wells.

9. If double bottoms under holds are used for carrying oil fuel, the ceiling must be laid on transverse battens, leaving at least 2 in. air space between the

ceiling and tank top, and permitting free drainage from the tank top into the limbers.

10. The pumping arrangements of the oil fuel compartments must be absolutely distinct from those of other parts of the vessel and must be submitted for approval.

11. If it is intended to carry sometimes oil fuel and sometimes water ballast in any of the compartments, the valves or cocks connecting the suction pipes to these compartments with the ballast donkey pump and those connecting them the oil fuel pump must be so arranged that the oil may be pumped from any one compartment by the oil fuel pump at the same time as the ballast donkey is being used on any other compartment.

All oil fuel suction pipes should have valves or cocks fitted at the bulkheads where they enter the stokehold, capable of being worked both from the stokehold and from the deck. Valves or cocks similarly worked are to be fitted to all pipes leading from the settling or service tanks.

13. Oil fuel pipes should, where practicable, be placed above the stokehold and engine room plates, and where they are always visible.

14. No wood fitting or bearers are to be fitted in the stokehold spaces.

15. Where oil fuel compartments are at the sides of, or above, or below the boilers, special insulation is to be fitted where necessary to protect them from the heat of the boilers, smoke boxes, casings, etc.

16. Water service pipes and hoses are to be fitted so that the stokehold plates can at any time be flashed with sea water into the bilges.

17. If the oil fuel is sprayed by steam, means are to be provided to make up for the fresh water used for this purpose.

18. If the oil fuel is heated by a steam coil the condensed water should not be taken directly to the condensers, but should be led into a tank or an open

funnel mouth and thence led to the hot well or feed tank.

		From San Francisco to Honolulu.			Honolulu to San Francisco.						
		Jan. 29.	Jan. 30.	Jan. 31.	Feb. 1.	Feb. 2.	Feb. 12.	Feb. 13.	Feb. 14.	Feb. 15.	Feb. 16.
Steam Pressure in lb. per sq. in.—											
At Boilers	230	230	230	230	230	230	230	230	230	230	230
Throttle valve	212	212	212	212	212	212	212	212	212	212	212
I. P. receiver	56	56	56	56	56	56	50	50	50	50	50
L. P. receiver	11	11	11	11	11	11	10	10	10	10	10
Vacuum	27 in.	27 in.	27 in.	27 in.	27 in.	27 in.	27 in.	27 in.	27 in.	27 in.	27 in.
Revolutions per minute	78.0	80.2	80.1	80.1	80.2	70.8	75.2	74.7	74.7	75.5	74.7
Speed in knots by observation	368	431	434	417	409	375	372.3	369	347	345	345
Slip of propeller, per cent.	12.2	6.3	5.7	9.2	11.1	11.9	10.6	10.6	15.7	12.2	12.2
H.P. of main engines by calc.	8,289.2	8,711.5	8,808	8,851.5	8,392.8	7,807.9	7,735.4	7,709	7,369.7		
H.P. of auxiliary engines, estimated	1,243	1,307	1,321	1,328	1,324	1,171	1,160	1,156	1,106		
Feed water temperature	220°	230°	226°	220°	220°	220°	220°	220°	220°	220°	220°
Engine room temperature	94°	95°	98°	98°	98°	96°	96°	94°	94°	94°	94°
Fire room temperature	80°	115°	114°	118°	119°	115°	110°	107°	107°	106°	106°
Fuel oil temperature	200°	180°	180°	180°	180°	190°	180°	170°	170°	170°	170°
Stack temperature	510°	510°	510°	510°	510°	510°	510°	510°	510°	510°	510°
Fuel oil consumed for 24 hr.—bb1	670	741	730	745	750	590	620	645	630	630	630
Smoke scale—5		1	1	2	2	2	2	2	2	2	3
No. of boilers and burners used—											
B. and W.	6	6	6	6	6	5	6	6	6	6	6
Scotch	3	3	3	3	3	2	0	0	0	0	0
Burners	37	38	39	39	39	31	30	30	30	30	33
Fuel oil pressure	200	180	180	180	200	180	180	180	180	180	180
Total I. H. P.	9,532	10,018	10,129	10,179	10,226	8,979	8,895	8,865	8,475		
Oil consumed per I. H. P.	.98	1.03	1.01	1.002	1.02	.92	.97	1.02	1.04		
Average analysis of flue gases—											
CO <sub>2</sub>	13.2										
O	1.2										
CO	.2										
Size of engines—											
35 in. x 62 in. x 2 x 81 in.											66 in.

## Steam Trials of U. S. R. C. Golden Gate.

B. & W. Water Tube Boiler, Triple Expansion Engine, Condensing.			
Run, number, November 23, 1911....	1	2	3
Duration, hours .....	1.5	1.5	1.0
Water Evaporated, Totals for Run, lb.—			
Main engine and auxiliaries, lb... ..	5,637.50	7,981.00	7,664.50
Fuel oil as fired, total for run, lb..	484.50	618.00	603.00
Fuel oil corrected for moisture, total .....	482.08	614.90	600.00
Oil pump, lb.....	111.00	130.50	98.00
Oil burners, for atomizing, lb.....	186.75	220.50	250.50
Total for all purposes, lb.....	5,935.25	8,332.00	8,013.00
Total equiv., from and at 212° F..	7,016.55	9,798.43	9,098.76
Water per Hour, lb.—			
Main engine and auxiliaries.....	3,758.30	5,320.66	7,664.50
Oil pump .....	74.00	87.00	98.00
Oil burners .....	124.50	147.00	250.50
Total for all purposes .....	3,956.80	5,554.66	8,013.00
Total equiv., from and at 212° F..	4,677.77	6,532.29	9,098.76
Fuel oil corrected for moisture, per hour .....			
Evap. lb. water per lb. oil per hr....	12.31	13.55	13.35
Evap. lb. water pr. lb. oil, equivalent.	14.55	15.99	15.16
Factor of evaporation.....	1.182	1.176	1.135
Total heating surface, sq. ft.....	2,034.00	2,034.00	2,034.00
Total grate surface, sq. ft.....	50.00	50.00	50.00
Evap. per. sq. ft. heat. surface, per hr. apparent .....	1.94	2.73	3.94
Evap. per sq. ft. heat. surface, per hr. equiv. ....	2.99	3.21	4.47
Per cent of total apparent evap. for atomizing oil .....	3.15	2.65	3.12
Per cent of total equiv. evap. for atomizing oil .....	2.66	2.25	2.75
Efficiency of boiler, per cent.....	75.40	82.55	78.50
Pressure by Gauge—			
At boiler .....	145.00	145.00	144.00
At engine .....	135.00	135.00	133.00
First receiver .....	11.00	21.00	36.00
Second receiver .....	—7.00	—1.00	4.00
Vacuum, inches .....	23.00	23.00	23.00
Oil to burners .....	45.00	45.00	45.00
Temperatures F., Degree, Average—			
Injection .....	55.00	56.00	56.00
Discharge .....			
Feed .....	83.00	89.00	125.00
Stack .....	409.00	453.00	516.00
Fuel oil to burners.....	122.00	124.00	123.00
Revolutions per Minute, Average—			
Main engine .....	103.20	125.90	147.60
Circulating engine.....	198.00	206.00	300.00
Air pump, double strokes.....	59.00	68.50	56.00
Feed pump, double strokes.....	10.00	16.00	34.00
Indicated Horsepower—			
Main engine, H. P. cylinder.....	46.73	81.74	117.14
Main engine, I. P. cylinder.....	48.32	84.61	132.40
Main engine, L. P. cylinder.....	38.83	70.37	127.77
Main engine, total .....	133.88	236.72	377.31
Horsepower of auxiliaries, estimated.	14.40	17.10	19.54
Total h.p., main engine and auxiliaries	148.28	253.82	396.85
Water per hr. per h.p., apparent, lb..	25.34	20.96	19.31
Water per hr. per h.p., equivalent, lb.	29.90	24.65	21.82
Fuel oil per hr. per h.p., total.....	2.17	1.61	1.51
Fuel oil per hr. per I. H. P.....	2.40	1.73	1.58
Fuel Oil—			
Specific gravity.....	0.952	Fire point .....	280.
Degrees Beaume.....	17.0	Caloric value, B.t.u.....	18,648.
Flash point.....	190.	Moisture .....	.005

Respectfully submitted,

WM. L. MAXWELL,

2d Lieut. of Engineers, U. S. R. C. S.

The cylinders of this engine have not been rebored for fifteen years, which accounts for high water rate per indicated h.p. per hr.; also high fuel oil rate per engine h.p. hr.

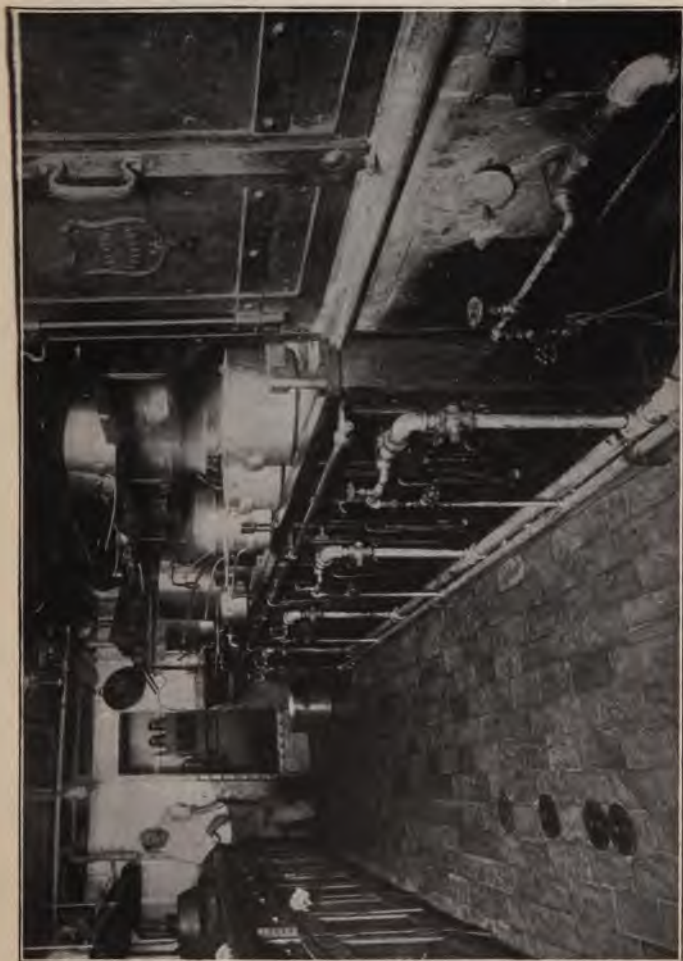

Fig. 92. Oil Burners in Ranges and Bake Oven in Galley of S. S. Bear.

## CHAPTER XIV.

### FUEL OIL FOR DOMESTIC PURPOSES.

Fuel oil is now extensively used in homes, hotels, clubs and apartment houses. In districts where coal costs from \$10.00 to \$12.00 per ton and oil sells for 80c per barrel, the consumer saves about 70 per cent by using oil. Oil fuel has been welcomly received in the home by the housewife. The question of "who shall carry up the coal and chop the wood," has been eliminated, and there is no more getting up a half-hour early to start the morning fire.

The equipment for burning oil in the kitchen stove is so simple that anyone can make it. Fig. 93 shows the method used in towns and counties not having strict regulations. The oil storage tank is placed on a scaffold, erected at a sufficient height to allow the oil to flow by gravity to the burner. A simple hand pump is used to pump the oil from the barrel into the storage tank. No changes in the stove are necessary other than removing the grate. The fire is started by placing a lighted paper near the burner, turning on the oil valve, and closing the top cover. Any size of fire can be readily obtained by regulating the supply of oil.

One of the most simple burners used in stoves or hot water heaters is the S and P stove burner. It is installed by removing enough of the grate so that the air pan is clear below the grate and any open space around the burner plate is filled in with fire clay and brick, making it air-tight. This allows the air to pass up through the burner. The burner is fitted with a





Fig. 93. Domestic Oil Burning System for Country Home.

## CHAPTER XIV.

### FUEL OIL FOR DOMESTIC USE

Fuel oil is now extensively used in small boilers, heat-clubs and apartment houses. In most low pressure and oil with the costs from \$10.00 to \$12.00 per ton, the supply of oil to the consumer saves by using oil. Oil fuel has been introduced by means of a rod in the home by the housewife. The rod is connected to the stove. The valve on the rod is lowered, closing the stove. The equipment for burning fuel oil is made to regulate the flow of oil to the burner.

The equipment for burning fuel oil is made to regulate the flow of oil to the burner. It consists of a storage tank, a pump, a valve, and a chimney. The pump is used to pump the oil from the storage tank to the burner. The valve is used to control the flow of oil to the burner. The chimney is used to carry the smoke and gas from the burner to the outside. The equipment is so simple that anyone can install it. The method used in installing the equipment is shown in the following diagram.

One of the most simple methods of controlling the flow of oil to the burner is the S. This method is shown in the following diagram. The S is a valve which is operated by means of a rod. The rod is connected to the burner. The valve is lowered, closing the burner. The equipment is so simple that anyone can install it. The method used in installing the equipment is shown in the following diagram.



needle regulating valve and operates by gravity requiring only a few pounds pressure. Stove and heater burners are made in various sizes, and burn a grade of oil known as stove oil. This is an oil or distillate of about 28 degrees Be. gravity. The amount of oil consumed per day in the average kitchen stove is about one gallon for each member of the family. Burners under hot water heaters and hot air furnaces consume about 7 gallons of oil daily. The method of installing these gravity types of stove burners is shown in Fig. 94.

There are many ways of automatically controlling and regulating the supply of oil in small boilers, heaters and furnaces. The method used most in low pressure systems that supply both air and oil with the same motor, is to regulate the supply of oil to the burner only. This is accomplished by means of a rod attached to the safety valve, and connected to the valve supplying oil to the burner. The valve on the boiler is set to the required pressure, and as this point is reached the connecting rod is lowered, closing the oil supply to the burner. No attempt is made to regulate the amount of air supplied.

Devices have been contrived to automatically stop the motor in case of fire caused by the overflow of burning oil in front of the furnace. In some of these, a string running along the floor in front of the furnace is connected to the switch that controls the motor. When the string burns the supply of oil is shut off, as the string releases the switch at the motor. In another a thermostat is placed in the chimney and set at a certain temperature. If the fire happens to go out, the temperature in the chimney is lowered, and this causes the thermostat to act; by means of an electrical device, the switch controlling the motor is thrown out and an electric bell is rung, thus notifying the attendant that the fire is out. The electric bell may be placed in any part of the house where it can be easily heard. Some of the devices which are operated by means of a string placed in front of the furnace, or a wire con-

nected to a valve on the boiler, are actuated by a diaphragm type of automatic circuit breaker.

In cases where all of the air supplied by the compressor is not being used, an unloading device is installed on the air inlet to the compressor, and when the proper pressure of air is attained, the unloader closes the air inlet. Air relief valves are also installed to prevent an over pressure of air in case the device does not work. While these many devices do not result



Fig. 94. S. & P. Stove Burner.

in the highest efficiency, viewed from the standpoint of fuel economy, because of the amount of excess air supplied, they eliminate the expense of constant attendance. Many of these installations that have been installed in small hotels and apartment houses are being cared for by the bell boys and landladies, the installations being so simple that they practically take care of themselves.

The installation of fuel oil burners for the U. S. Government at Fort Baker, Cal., is an interesting example of the practice of burning fuel oil in a number

of buildings by a system operated from one central plant. Many corporations owning large properties containing various departments, offices, employes quarters, etc., have considered the feasibility of using such system for heating and cooking purposes. The installation at Fort Baker was the first attempt on a large scale and its successful operation opens up an entirely new field of application for the use of fuel oil.

It has even shown the possibility of community



Fig. 95. Oil Burning Range.

use of fuel oil in large cities. There is no reason why cities cannot serve their inhabitants with fuel oil, just as they are now served with water, gas, steam, and electricity. Oil and air lines can be run under the streets in the same manner as water mains. The regulations of the Fire Underwriters and the cities should be changed to encourage the use of fuel oil in this manner, for the fire risk would not be so great as with the present method of storing oil in tanks located in basements, etc. Fuel is one of our great municipal problems, and there is no better way to reduce the cost of living than to reduce the cost of fuel.

The main storage reservoir at Fort Baker has a capacity of 100,000 gallons of oil, and is situated at an elevation of 100 ft. It is constructed of red rock lined with five inches of concrete, which was sprayed onto Clinton wire fabric with a cement gun. The top of reservoir is covered and properly vented to allow the escape of any gas that may form. The oil is pumped direct to the reservoir from oil tank steamers at the wharf. From the main reservoir it is pumped into



Fig. 96. Heating Furnace in Officers' Quarters.

10,000-gallon distributing tanks by a belt-driven triplex pump, operated by an electric motor. These smaller reservoirs are located at an average elevation of 200 ft. and are constructed of reinforced concrete.

The oil flows by gravity through 4 in. wrought steel pipes throughout the entire government reservation. The pipes are reduced to 2 in. at the entrances of barracks and houses. The oil supply to each building is provided with a pressure regulation valve set at 30 lbs.; there is also an automatic cut off valve. The oil consumption of each building is recorded by a disk type oil meter, fitted with an oil

strainer and by-pass. Great care had to be exercised to lay the oil lines absolutely tight; provision for expansion and contraction was made by inserting U bends bedded in sand at intervals of 300 ft. The oil lines are controlled by gate valves, and so arranged that any individual part of the system may be cut off without interfering with the operation of the rest of the system.

Fig. 97 shows in outline the general arrangement of the system.

A compressor plant is located at the substation A. It contains two centrifugal air compressors, each with a capacity of 750 cu. ft. of free air per minute under a pressure of two pounds. These are driven at 3400 r.p.m. by alternating current motors of 10 h.p. It was estimated that the California crude oil used would have a heat value of 18,000 B.t.u., and that one gallon of oil would require 1875 cu. ft. of free air for combustion. The air line from A to B is 965 ft. and is made up of 120 ft. of 6 in., 225 ft. of 5 in., 670 ft. of 4 in., and 150 ft. of 2 in. pipe. The frictional loss is estimated at 3.279 oz. The air line from A to C is 1160 ft. long, and is made up of 290 ft. of 6 in., 100 ft. of 5 in., 420 ft. of 4 in., 210 ft. 3 in., and 140 ft. of 2½ in. pipe. The frictional loss is 12.57 oz. The air line from D to E is 465 ft. long, and is made up of 175 ft. of 4 in. and 290 ft. of 3 in. pipe. Frictional loss is 4.12 oz. The air lines are laid in the same trench as the oil lines and are provided with a shut off valve at the entrance to each building.

The average amount of oil used monthly is 5068 gallons, costing \$107.50, 2620 kw. of electric power are also used, costing, at 3c per kw., \$78.60. This makes the average monthly total cost for fuel, \$186.10, a saving of 70 per cent over the cost of coal fuel. The cost per hour for an army range, using about 1½ gallons of oil per hour, is about 3c, including electricity used for pumping oil and air. There are 37 separate oil burners operated by this system and the entire cost of the installation was \$15,025, of which \$4350 was for



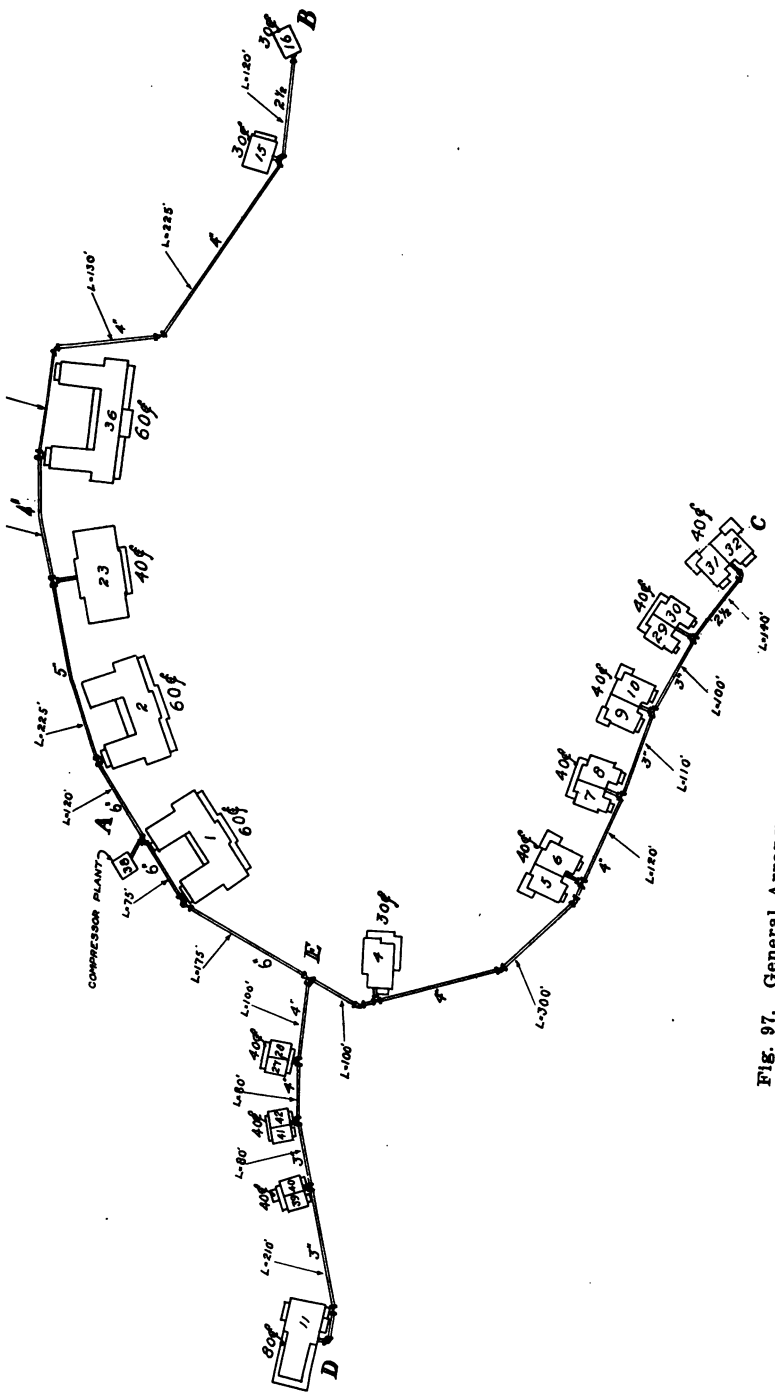

Fig. 97. General Arrangement of Oil Burning System at Fort Baker.

oil storage tanks and pumps, \$4295 for oil pipe lines and \$6380 for the air lines, compressors, burners,



Fig. 98. Bake Oven Oil Burning Equipment.



Fig. 99. Fessco Crude Oil Burner.

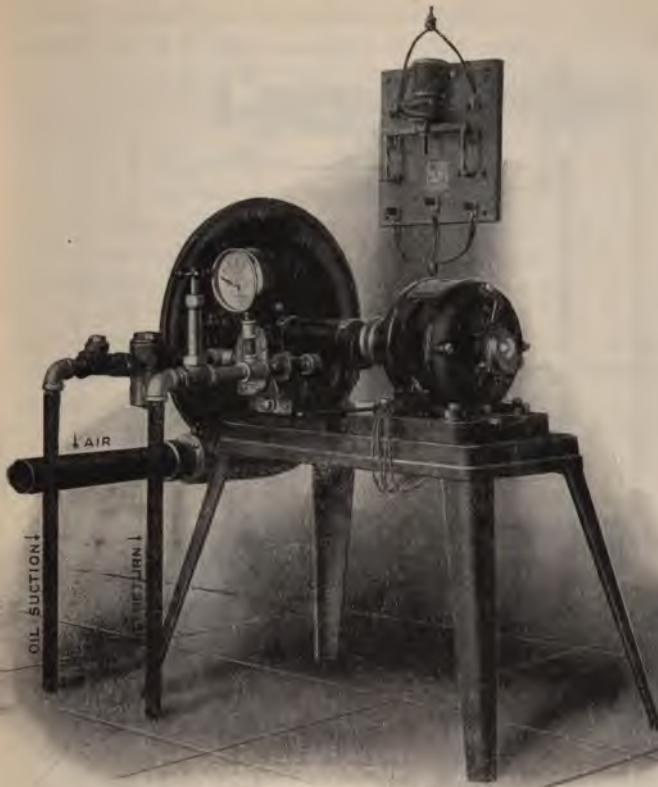

Fig. 100.

valves, etc. Fig. 96 shows a view of an installation in one of the army officers' quarters. This furnace is used for heating purposes. Fig. 84 shows the burners fitted to a set of army ranges in the quarters or barracks for the soldiers. Fig. 95 shows the method used to equip a modern bake oven.

Fig. 99 illustrates the Fessco crude oil burner applied to range—with section of firebox cut away showing the soft, mellow flame, insuring uniform distribution of heat, without the usual high pressure destructive blast. With air at six ounces pressure, the

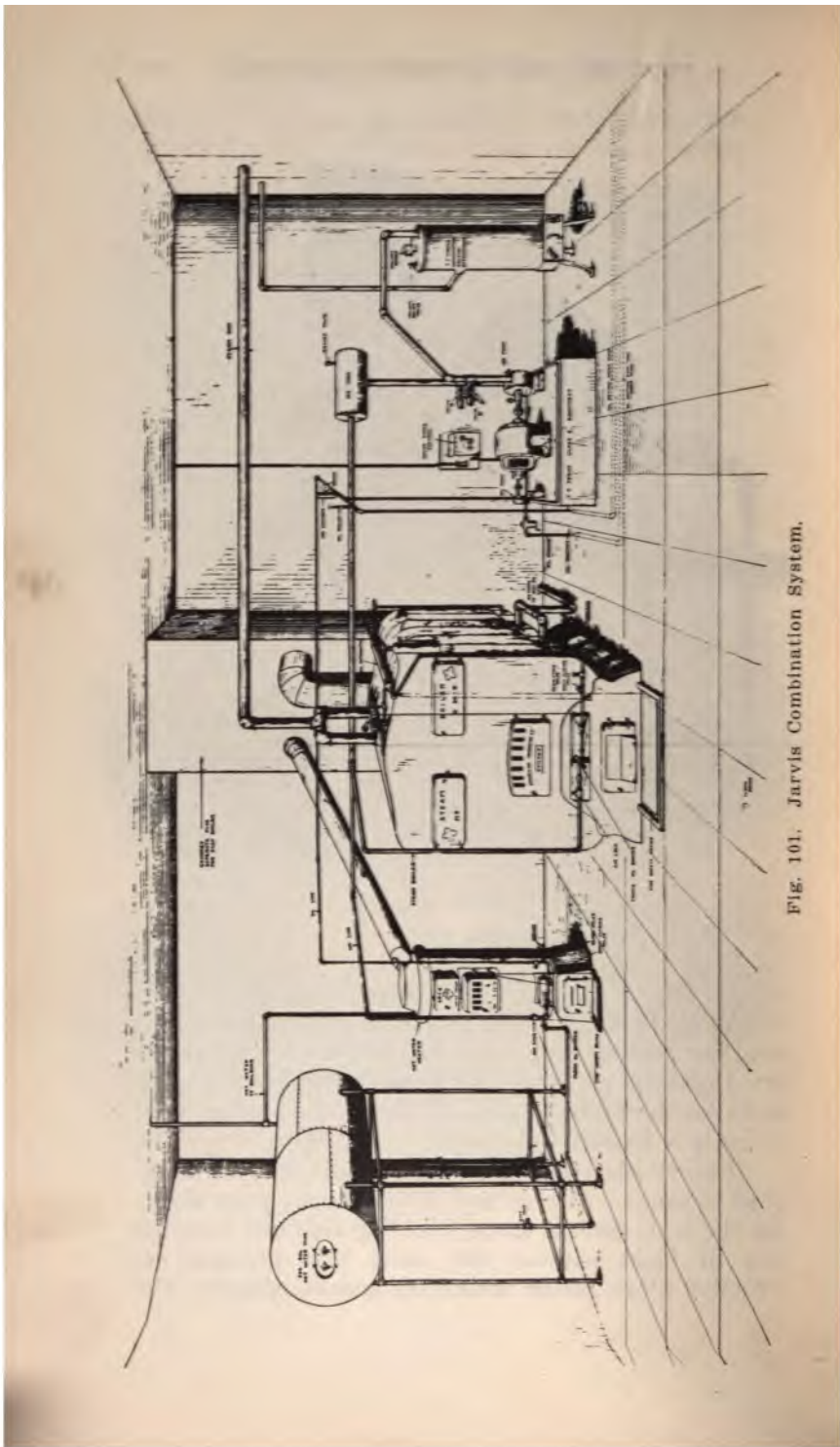

Fig. 101. Jarvis Combination System.

burner produces a smokeless combustion of high efficiency which is only possible by the unique construction of the burner to which the oil is supplied through strainer (convenient for cleaning) and single needle valve control.

The equipment for supplying the burner with oil and air is a compact unit consisting of 1/3 h.p. or larger motor (depending on the capacity), worm reduction gear for driving oil pump and fan, all securely mounted on a rigid cast iron base plate cast concaved to provide a drip pan. It is supported by heavy cast iron legs 22 in. in height to permit of convenient inspection and lubrication, and may be located where convenient within 100 ft. of range or heater, as shown in Fig. 100.

Fig. 101 shows the method of installing the Jarvis combination vacuum sweeper and oil burner system. It was devised to meet the needs of apartment houses, and hotels that required a simple and fool-proof system of burning oil and operating the vacuum cleaners. It being automatically controlled, requires but very little attention.

Considerable saving can be made on the first cost of installation and cost of repairs as it requires but one motor and one pump.

Liquid fuel for baking or cooking has many advantages over wood fuel for firing bakers' ovens, a saving obtained of 70 per cent in fuel bills, with addition to this saves time, waste, and space in storage of fuel, chopping, handling, wear and tear of ovens, raking and mopping out the oven, cartage and dust accumulation, with the use of liquid fuel, for its simplicity, cleanliness, and economy in operation is an important factor for the sanitary bakeries.

In this cut we clearly illustrate the T. P. Jarvis method of applying crude oil burners to bakers' ovens, of the center fire, wide mouth, continuous type oven, or the side fire Dutch oven or direct fire pastry oven. The burner is shown in firing position under the center, wide mouth continuous oven, this method as applied for installation of crude oil burners having gained considerable merit for the purpose as shown, and may

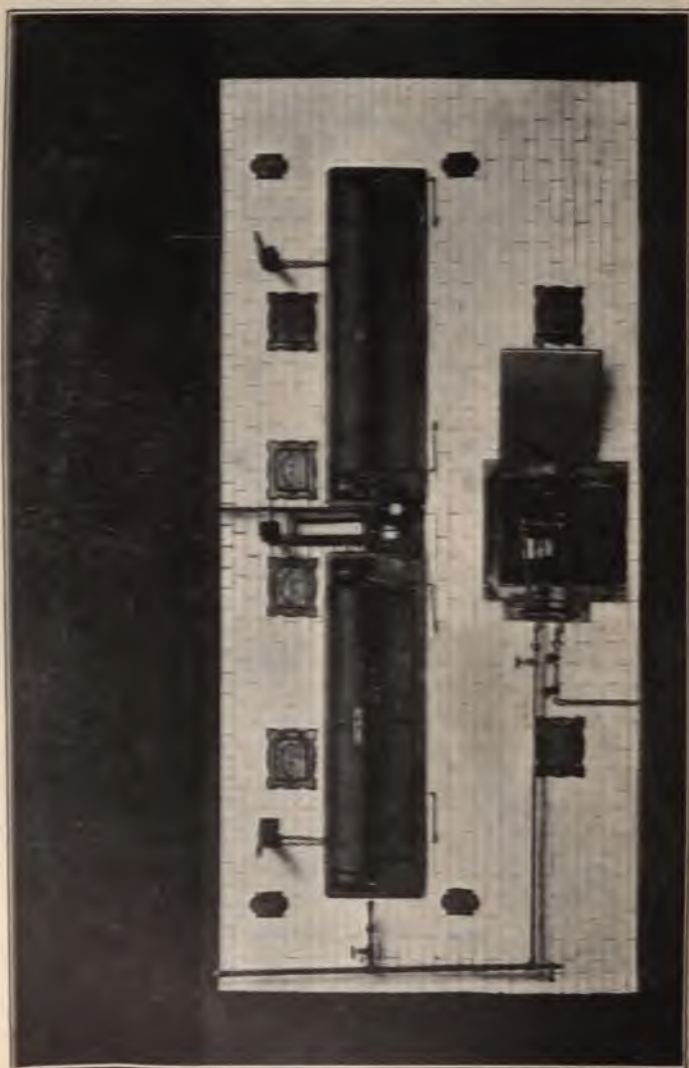

Fig. 105. T. P. Jarvis Swinging Jet Burner Installed in Bake Oven.



Fig. 103. Vulcan Automatic Burner.

operated for any desired firing position with much ease for the operator, and when through firing and the required temperature of the oven has been obtained the burner may be swung out and set flat against the side of the oven. This arrangement leaves the burner always

accessible for cleaning or adjustments, without scorching the hands with the intense furnace heat as experienced with the old method of stationary burners.

The burners, as shown, being of the latest type 1915 model patented, set upon a bracket with non-leakable swinging joints, adapted for use with high or low pressure air or steam for atomizing. Adapted and used for burning of crude oil of the cheapest grade, with a steady high heat flame, free from smoke and soot, the burner being arranged and constructed that the heat from the furnace does not effect the burner.

The Vulcan crude oil burning system consists of either the standard or automatic burner, fuel storage tank, and necessary pipe and fittings for steam connection from boiler to burner, and oil suction line from burner to oil storage tank. No pumps, receivers or auxiliaries common to other oil burning systems are required. There is embodied in the design of the burner, the ejector principle, whereby the steam which atomizes the oil passes through the burner, creating a partial vacuum within the suction line leading from the oil supply to the burner. The partial vacuum thus created dispels all air from the suction line and draws the oil into the burner, from whence it is carried through the burner at a high velocity and thoroughly atomized before passing into the furnace.

The Vulcan automatic crude oil burner will automatically maintain, within reasonable demands, a constant pressure within the boiler without attention from the operator. The valve of the regulator is not subject to cutting action of steam, and foreign matter in the oil cannot affect its operation, as neither steam nor oil pass through this valve.



## CHAPTER XV.

### THE ROTARY SYSTEM OF BURNING OIL.

One of the earliest methods of atomizing employed by engineers in experimenting with the use of oil as a fuel was the centrifugal action of a rapidly rotating jet. French engineers, during their early trials, constructed a device that employed centrifugal action for spraying the oil, and used low pressure air as an atomizer. The oil used during these tests was similar to coal oil. It was not possible to operate the burner without the formation of large volumes of smoke; and the evaporation of water per pound of oil was only  $8\frac{1}{2}$  lb. The mechanism was cumbersome and expensive.

During the tests conducted by the U. S. Naval Liquid Fuel Board under a Hohenstein boiler, the question of using the rotary method was given special consideration. As the possibilities of spraying oil by means of centrifugal force looked feasible, a burner was designed to utilize a ring of buckets which was formerly part of an experimental steam turbine. In this turbine there were five rings like the one used in the burner. The turbine was compounded in such a way that the outputs of power from the five rings were equal. The turbine, at a speed of 15,000 revolutions per minute, gave 20 horsepower. By the use of diverging steam nozzles the single ring, as used in the burner, should give an efficiency somewhat higher than one-fifth that of the compounded turbine. In other words, the burner turbine should, at a speed of

15,000 revolutions per minute, yield more than one horsepower on 100 lb. of steam per hour.

In designing the burner, however, the consumption of steam was assumed at 400 lb. per h.p.-hr. This was to allow, among other things, for the unknown viscous resistance of the film of oil flowing from the center of the disk to the periphery. Even with this seemingly ample allowance, only one-ninth as much steam should be required as in the simple jet burner. A number of tests were conducted, and many changes were made in the furnace and adjustments. The following extracts for the report will give the reader an idea of some of the difficulties that had to be overcome:

"Nov. 3, 1902.—Made a disk of sheet iron 1-16 in. thick and 10 in. in diameter, and fastened to burner in such a manner that the oil flows over its upper surface. Assembled burner and repaired circular furnace, making it 33 in. high and 4 ft. in diameter. Tried burner at 5 p. m. It seemed to work satisfactorily in all respects. The oil was able to protect the disk from overheating during the few minutes that the experiment lasted. Speeded up turbine without igniting oil and caught samples of spray on blotting paper.

"Nov. 8, 1902.—Repaired brick walls. Steam at 90 lb., oil at 25 lb. Turned on steam. The burner began spinning around, and soon attained speed. Ignited some kerosene-soaked waste and dropped it beside burner. Turned on oil. There was instant ignition. Stepped aside to observe the effect. More oil was being supplied to the burner than it could take and spray properly; much oil was escaping downward from the burner. Could not shut off the oil at the valve on account of intense heat. Ordered it shut off at the pump. Oil continued to flow on account of oil chamber on pump. Something exploded and demolished one side of the furnace. The turbine ring had broken loose. The ring was nearly driven onto the cast iron center. The heat and centrifugal force had been sufficient to expand it to the degree of making it loose. When it tore off the 19 in. disk, the cast iron center continued to spin for some time. Half of the buckets were torn off the turbine ring.

"Nov. 15, 1902.—Assembled the two-jet burner and connected pipes as before, instead of a brick wall around burner,

Two curved plates of boiler steel were used. The lower edges of the plates were lifted off the ground by the thickness of three bricks. The plates made an enclosure about five feet in diameter and four feet high. Turned on steam from the main boiler. Placed some oil-soaked waste on the ground within the enclosure and ignited it. Oil pump started and orders given to keep oil pressure at about 20 lb. When the oil valve was opened there was instantly an intense combustion within the enclosure; the heat was so great that the oil supply had to be reduced. The volume of the fire was as easily controlled as a common gas jet. After about five minutes the burner went to pieces, caused by the backing out of the supporting pipe where it screws into the pipe fitting on the pedestal.

"Summary.—The steam pivot burner was a failure from the start, and it is not considered advisable to attempt to correct its faults. The solid pivot burner failed at first because the oil was not thrown off from its greatest diameter, and afterwards because some of the oil escaped downwards and burnt underneath, thus heating the burner and finally from the parts not being securely fastened together.

#### Conclusions as to Centrifugal Burners.

"First.—The oil should be thrown off from the largest diameter of the burner.

"Second.—The burner must be so arranged that the only outlet for the oil leads to the intended spraying edge. The construction of the experimental burner was such that part of the oil went wrong when the amount fed was greater than a certain maximum or less than a certain minimum.

"Third.—The oil should be introduced at the center of the spraying disk and flow over the whole of the surface exposed to the radiant heat.

"Fourth.—All parts should be secured by fastenings, which are more reliable than mere friction, however great; otherwise the very high speed of rotation will shake them loose.

"Fifth.—There is no evidence that the amount of oil flowing through the burner is not amply able to keep it at a safe temperature. In fact, the cooling power of oil, compared to the amount of surface of the burner is many times greater than the cooling power of water compared to the heating surface of a boiler. The ratio is from 25 to 200 or 300 in favor of oil.

"Sixth.—By leading the air required for combustion in along the burner head or burner mechanism, the amount of air can itself be made to absorb much of the heat which the disk receives from radiation, the air thus constituting a cooling medium in the mechanism.

"Seventh.—These experiments were all conducted in the open air and some of them in the wind. Hence there were few if the benefits derivable from the presence of glowing furnace walls. How much this affected the results is of course uncertain, but it is the opinion of many who witnessed the experiments that the presence of hot furnace walls would have resulted in a very great improvement."

From the above experiments Mr. William A. Fessler of San Francisco, Cal., was conducting experiments with a variety of revolving burners. He at once discovered that oil could not be burnt in a solid body or in a thin film of spray without the assistance of an atomizing agent or break up the oil into minute spheres. The use of a steam atomizing agent would require a steam generator and the expense of such a generator or the necessity of steam for atomizing was one of the items that he was trying to eliminate. The use of an air compressor was also considered as expensive and cumbersome. The local demand required an oil burner that could be started by a simple operation and that would not require constant attendance by the operator. The Fessler system is the result of many experiments conducted in the laboratory of chemical research maintained by his company.

The Fessler rotary mode of burner is what might be called a "mechanical burner" due to the fact that the atomization is performed by means of a rotary wheel without the use of steam or compressed air. The mechanism is driven by an electric motor mounted on a wooden insulating block on the base frame of the system. The bolts holding it in position are set in fibre insulating bearings so that the motor is absolutely isolated from the base frame.

The universal joint in the shaft between the motor and the worm gear allows perfect freedom of motion of the motor armature in its bearings without hind-

ing, due to any inaccuracy in the perfect alignment of the shaft. The bearings of the worm shaft in the worm case are lubricated by two oil rings which dip into the oil supply in the bottom of the worm case, which is constructed to form a reservoir for the supply of lubricating oil. The worm and gear are lubricated from the bottom of the gear, which runs below the surface of the oil in the reservoir. The worm operates against a ball thrust bearing in the worm case, composed of a race and two case hardened washers. All bearings are made of bronze with removable bushings. The worm is made of steel and the gear of bronze.

The oil pump is of the twin gear rotary pattern, entirely constructed of bronze, with a steel driving shaft connected to the worm gear shaft by a male and female slot. Special attention has been given to the size of the pump stuffing box. By disconnecting the two unions on the oil supply and discharge pipes the pump can be readily removed from the base.

The shaft between the worm gear case and the gear box under the boiler is a steel shaft fitted to the large gear shaft in the gear box by a male and female groove, and to the worm case shaft by a flexible, ball-centered coupling. By removing the four coupling screws and the set screw on the shaft, it can be entirely removed.

The gear box is the housing for enclosing the bevel gears which transmit the motion from the horizontal driving shaft to the vertical shaft supporting the revolving head. The large driving gear is supported on a shaft running in a removable bronze bushing carrying a ball thrust. The hollow vertical spindle is carried by a ball bearing consisting of a concave, case hardened race-way, and a case hardened flat washer, all housed by a removable bronze bushing. On the revolving shaft is a steel pinion meshing with the bronze driving gear carrying a hollow spindle into which the head spindle fits with a taper joint. Through the center of this hollow spin-

the oil and spindle carrying the waste oil through the gear box and to the oil distributing disk of the burner head. By the misting system all of the bearings are automatically misted, the overflow being carried back to the main reservoir.

On the bottom of the head or hub is constructed the primary air fan of the propeller type which handles all the air that is supplied to the burner. At the top of the hub there are two sections of the secondary fan which are of the multivane type and they deliver the air both below and through the oil spray. The oil atomizing gun carries an oil through at the bottom under a pressure constantly a thin film of oil which by capillary attraction connects with the film of oil fed to the oil disk from the supply line in the hollow spindle. This forms a continuous ring of oil when the head is in motion and causes an absolutely even distribution of oil over the entire periphery of the oil disk at the point where the oil leaves the head and enters the furnace. This condition assures an even fire that will burn with a steady flame without puffing or blowing out. The top of the head is carried by the continuation of the oil feed spindle and is stationary. It is covered with a cap of fire-proof concrete.

The fire-box end of the bed plate has four supporting legs carrying a cast iron floor plate from which radiate four truss supporting the fire brick of the furnace. Below the floor plate are two grooved guides carrying an adjustable air damper by which the air supply to the fans can be controlled, and perfect combustion of the oil maintained. The damper is operated by a rod extending to the front of the furnace. The bed plate of the machine contains milled grooves and pads by which the gear box and the worm case are accurately aligned and the gear box is held in place by a clamp screw which forces it against a stop at the rear end of the bed plate.

The starting device for the motor consists of a double throw spring lever switch, so arranged that in

starting, the switch is thrown into the lower lugs, which are connected onto the line without fuses; after the motor has reached its normal speed the switch is quickly thrown onto the upper lugs. The motor is thus operating on a line connected through fuses of ample capacity. It is impossible to leave the switch on the lower unfused lugs, for the springs immediately throw the switch out if the hand is removed. A solenoid trips the switch upon any failure of the current, and the motor automatically stops. A separate switch is provided for each oil burner in the plant, and each motor is therefore entirely independent of the other.

To operate this system, it is only necessary to throw in the switch, watch until the oil is up to the required pressure, and then place in the furnace a small piece of lighted paper, which immediately ignites the oil. The pressure required on the boiler can readily be adjusted by means of a siphon regulating valve which is connected to the oil supply valve by means of a rod. This system has been known to operate without any attendance, other than when starting, for months at a time.

While the Fess system will work perfectly under almost any type of boiler, it has been installed most in heating plants in hotels, homes, public buildings, schools and apartment houses. The reason for this is that it is entirely reliable and requires little attention. With other types of oil burning installations, a great deal of the attendant's time is required to adjust the burner to meet the fluctuations in the load on the boiler.

The following test was conducted by a consulting engineer and an engineer representing a local school board in order to determine the efficiency of the Fess Rotary System:

## Rating of Boiler—2625. S-36-6 Ideal Boiler.

## Low Fire—2 Hour Test. Fess.

Total oil used .....	78 lbs.
Total water used .....	113 gal.
Temperature of feed.....	59
Temperature of boiler room.....	78
Temperature of stack .....	490
Developed load in sq. ft.....	2186
Per cent of rated load.....	83
Equivalent evaporation .....	14.008
Carbon in furnace.....	Trace
Smoke at top of stack .....	None
Noise of combustion .....	None

## Medium Fire—3 Hour Test.

Total oil used .....	167 lbs.
Total water used .....	245 gal.
Temperature of feed .....	59
Temperature of boiler room.....	81
Temperature of stack .....	580
Developed load in sq. ft.....	3159
Per cent of rated load .....	120
Equivalent evaporation .....	14.186
Carbon in furnace .....	Trace
Smoke at top of stack.....	None
Noise of combustion .....	None

## Heavy Fire—3 Hour Test.

Total oil used .....	184 lbs.
Total water used .....	269 gal.
Temperature of feed .....	60
Temperature of boiler room .....	83
Temperature of stack .....	630
Developed load in sq. ft.....	3465
Per cent of rated load .....	132
Equivalent evaporation .....	14.124
Carbon in furnace .....	None
Smoke at top of stack.....	None
Noise of combustion .....	None

Fig. 11 as shown on page 16, illustrates the Ray rotary crude oil burner. It is a distinct departure from the other types; being a combination of "air under pressure" and "rotary system." The air being supplied by means of a self-contained blower directly connected to an electric motor. The oil being fed to the burner by gravity or by means of a gem pump attached to the shaft of the motor.

The oil and air are discharged out of a nozzle like the ordinary straight-shot burner, the nozzle being so arranged as to allow room for a centrifugal atomizer.



This atomizer is small and cannot become overheated due to the air being passed over it.

The oil passing through the atomizer is brought to the flash point and burns close to the nozzle, as it is surrounded by a blast of air at this point and produces practically a perfect combustion.

As the air blast passes around the nozzle no oil can drop down beneath the burner front causing a formation of carbon.

The motors used on this type of burner are from  $\frac{1}{4}$  to  $\frac{1}{2}$  h.p. This method of burning crude oil has



Fig. 104.

been perfected recently, but is giving entire satisfaction wherever installed.

Engineers looking for improved methods in burning crude oil should investigate this type of burner, as it can be applied to almost any type of a heating furnace or boiler.

Fig. 104 shows this burner as applied to an ordinary range and can be operated on as low as  $\frac{1}{2}$  gal. of oil per hour.

The M. & W. mechanical oil burner is also of the rotary type, but is arranged to set horizontally. The oil is fed to the rotating head by means of a stationary tube that passes through the shaft. The oil pump is attached to the rear end of the motor and is driven by means of a gear connected to the motor.

The rotating head is provided with fan blades so arranged as to create sufficient amount of air for combustion, as well as to assist in the atomizing of the oil. It revolves at a speed of 3600 revolutions per minute.

The motor is of a standard type, fitted with a special hollow shaft and mounted in special end shields with Hess-Bright ball bearings. It is fitted with a thrust of ball bearing designed to take up the thrust of the oil pump worm drive.

The burner is fitted at the head with an automatically controlled shutter, which regulates the amount of air to a given amount of air. The shutter is operated by a lever arm controlled from the syphon valve. This arrangement prevents an excess amount of air from entering the furnace.

In large high pressure installations the air admission is regulated by the construction of a ring of ports, built into the furnace frame. This arrangement allows the primary air to pass in through the burner head, while the secondary air is adjusted by a damper controlling the ring of port openings.

The base is fitted with a shifting and locking device, so as to enable the operator to remove the burner from the furnace.

The burner is illustrated below, Fig. 105.



Fig. 105.

The following data are shown here in order that the engineer, architect, or owner may ascertain the approximate amount of fuel oil required for heating purposes in hotels, homes or apartment houses. Also the cost of oil is compared with that of other fuels, as wood, coal, gas, electricity or steam service from central supply stations.

This table is based on the following assumptions; by referring to the reports below on comparative consumption of the various fuels, it will be seen that the table is a fair average.

Electricity: Assuming that one square foot of direct radiation will heat an average of 50 cubic feet of space, then 500 square feet of radiation will heat 25,000 cubic feet. Figuring the heating value of one kilowatt hour at 3400 thermal units, and that 1 B.t.u. will raise the temperature of 54 cubic feet of air one degree, then 25,000 cu. ft. raised from 50 degrees to 70 de-

grees will require  $\frac{25,000 \times 20}{54} = 9,260$  B.t.u. divided by

3,400 = 2.73 kw. at 5c per kw. = \$ .1365 per hour or \$2.66 for ten hours.

Steam service: Assuming that one square foot of direct radiation together with pipe, etc., will condense 1-3 of a pound of steam into water per hour, then, 0.3 divided into 500 will give the amount of steam required per hour or .1667 times 60c for steam

Table of Oil Required for Heating Purposes as Compared With Cost of Electricity, Gas, Wood or Steam Heating.

H.P.	Boiler Ratings, Equiv.		Oil—gallons per day of 10 hours.	Sq. ft. of radiation.	Electricity at k.w.-hour.	Steam Heating		Gas at the foot 1000 cu ft.	Oil at the per gal.
	Steam.	hot water.				at the per 1000 lb. water.	Wood at the cord		
3.6	500	800	14	500	81.38	81.00	81.00	81.84	8.18
7.2	1000	1600	28	1000	2.72	2.00	2.14	2.00	.684
10.8	1500	2400	42	1500	4.08	3.00	4.77	4.00	.884
14.4	2000	3200	56	2000	5.44	4.00	6.00	6.00	1.07
18.	2500	4000	70	2500	6.80	5.00	7.00	6.70	1.20
21.6	3000	4800	84	3000	8.16	6.00	8.04	8.04	1.30
25.2	3500	5400	98	3500	9.52	7.00	11.10	8.88	1.40
28.8	4000	6000	112	4000	10.88	8.00	12.70	10.70	1.50
32.4	4500	6800	126	4500	12.24	9.00	14.81	12.18	1.60
36.	5000	7200	140	5000	13.60	10.00	16.80	14.40	1.70

= \$ .10002 per hour or \$1.000 for 10 hours per 500 sq. ft.

Pine wood: The average pine wood used for fuel is compared with oil as two barrels of oil being equal to one cord of wood; assuming that it costs .318c per day to heat 500 sq. ft. of radiation with oil as fuel at 90c per bbl. With wood at \$9.00 a cord  $2 \times 90 = 180$  divided into 900 = five times as much with wood or  $5 \times .318 = \$1.59$  per day of 10 hours to heat 500 sq. ft.

Gas: Assuming that one square foot of radiation gives off 250 B.t.u. per hour, then 500 sq. ft. will require 125,000 B. t.u., or 1,250,000 for 10 hours. This divided by 650 B.t.u. contained in one cubic foot of gas will equal 1923 cu. ft. of gas required, at a cost of \$1.34 with gas at 70c per 1000 cu. ft.

Oil: Assuming that one pound of oil will evaporate 12 lbs. of water and that 100 sq. ft. of radiation requires 33 1-3 lb. of water per hour, then 500 sq. ft. will require 166.6 lb., this divided by 12 will give 1.38 lb. of oil required per hour, times 10 = 138 lb. of oil daily. Oil at 90c per bbl. and 330 lb. per bbl. equals  $.0027 \times 138$  or \$0.373 cost of oil daily.

One B.t.u. will raise the temperature of 55 cu. ft. of air 1 degree.

One sq. ft. steam radiation gives off from 240 to 280 B.t.u. per hour.

One sq. ft water radiation gives off from 150 to 170 B. t.u. per hour.

One sq. ft. of average radiating surface under standard conditions condenses  $\frac{1}{4}$  lb. of steam per hour, surrounding air being at 70 degrees F.

One sq. ft. of active heating surface will evaporate about 3 pounds of water per hour, from and at 212 degrees Fah.

34.5 pounds of water per hour evaporated from and at 212 degrees Fah. equals one boiler horsepower.

One "horsepower" will supply 138 sq. ft. of average cast iron radiation under normal conditions of installation, and under such conditions 4 sq. ft of radi-

tion is required to condense one pound of steam per hour. The hourly evaporation in pounds times four gives the heating power in terms of radiation.

If the rated capacity of the boiler is based on actual tests and you wish to find the horsepower, divide the capacity by 138. Thus: capacity—2,720 sq. ft.—divided by 138 equals 19.7 horsepower.

A boiler that will burn 5.5 lb. of oil per sq. ft. of grate surface, which is the average capacity of heating boilers, and that will evaporate 14 lb. of water per lb. of oil, will make steam at the rate of 77 lb. per hour per sq. ft. of grate surface, and as direct radiation will, under favorable conditions, condense steam back to water at the rate of 0.3 lb. per sq. ft. per hour, we find by the division of 77 by 0.3 that 1 sq. ft. of grate will furnish sufficient steam to fill 256.6 sq. ft. of radiation.

The capacity of a house heating boiler to carry radiation is limited by its rate of combustion and evaporation. With coal as fuel the average heating boiler consumes 8 lb. per sq. ft. of grate, and evaporates about 9 lb. of water per lb. of coal. A boiler having 18.24 sq. ft. of grate area with an 8 hour rating of 4200 sq. ft. has been known to have evaporated 1848 lb. of water per hour. This is equivalent to about 40 per cent overload. The oil consumption was 132 lb. per hour, which shows a rate of 7.2 lb. of oil per sq. ft. of grate per hour and an evaporation of 14 lb. of water per lb. of oil.

Prof. R. C. Carpenter gives the following formula

$$R = \frac{1}{4} (G + \frac{1}{4} W + .02 n V.)$$

for direct heating by steam:

In which R = number sq. ft. radiation required.

G = glass surface.

W = exposed wall surface.

V = cubic contents of room.

n = number of times air in room is changed per hour.

This formula is for zero weather, in still air, in well constructed building.

Steam heating (Mill's Rule):

A very easy rule to remember is Mill's 2-20-200 Rule, in which the total amount of radiation required is obtained as follows:

$$\frac{\text{Glass}}{2} + \frac{\text{Exposed wall}}{28} + \frac{\text{Cubic contents}}{200} = \text{Sq. ft.}$$

of radiation.

Note—This rule does not work out well in the case of halls or rooms having less than ordinary amounts of wall and glass surface, where the opening and closing of outside doors changes the air frequently. In such cases the radiation should be increased 20 per cent or over.

The following report was recently sent to a local oil burning company, in answer to an inquiry as to the comparative cost of oil and steam service.

Replying to your recent inquiry, I beg to submit the following data on comparative cost of district steam at 60c per 1000 pounds of condensation and the cost of operating my own heating plant with fuel oil at 75c per barrel.

District steam from Dec, 22, 1912, in weekly bills as follows:	
December 22d .....	\$27.00
December 29th .....	24.60
January 5th .....	46.20
January 12th .....	36.60
	\$134.40

The cost of operating my own heating equipment for the month of January, 1913:

80 barrels of fuel oil at 75c .....	\$60.00
Lubricating oil .....	1.75
Repairing fire box .....	7.80
Estimated cost of electric current .....	4.50
	\$74.05

A total saving of \$60.35 for a month.

The size of the boilers are: Steam—Ideal S-36-8. Hot Water—Arco 1-25-W.

Report of cost of heating the Hearst Building, San Francisco:

Total radiation in building is.....	3750 sq.ft.
Hours operated daily .....	20 hours
Oil Consumptin for year of 1912.....	2076.8 bbls.
Average consumption daily .....	5.7 bbls.
Size of motor operating burner.....	¾ h.p.
Cost of operating motor daily.....	21c
Oil at 70c per barrel, electricity at 21c =	\$4.20 cost per day

**Report comparing the cost of gas and oil:**

"Since using oil as fuel for heating water for the use of tenants and also furnishing steam heat for the building, I have noticed the following comparison: The cost of the oil for both heating water and building does not exceed \$15 per month, as against a charge of \$40 monthly which I paid formerly for gas to furnish hot water for the tenants, without heating the building."

**Comparative report on coal and oil:**

Coal bills from Oct. 15, 1911, to Oct. 15, 1912.....	\$1105.00
(Coal at \$10 per ton.)	
Oil bill from Oct. 15, 1912, to Oct. 15, 1913.....	292.96
(Oil at 80c per barrel.)	
Electric bill for motors.....	57.64
(Electricity at 5c kw.)	

A saving of \$744.40 per year and the burners are operating more hours per day than when burning coal.

**Comparison of Heating Costs Between Gas and Oil.**

1. Building having 4 vacuum gas burning radiators.
2. Radiators operating 16 hours daily.
3. Gas cost on an average of \$ .28 per day.
4. Gas cost \$ .70 per 1000 cu. ft.
5. Manufactured gas contains as high as 650 B.t.u. per cu. ft.
6. Item No. 3 (.28) divided by item 4 (.70) per M = 400 cu. ft.
7. Item No. 5 (650)  $\times$  6 (400) equals 260,000 B.t.u. in 400 ft. of gas.
8. Crude oil contains an average of 18,000 B.t.u. per lb.
9. Crude oil can be bought at \$ .85 per barrel.
10. One barrel of crude oil contains 42 gallons.
11. Item No. 9 (85) divided by item 10 (42) = .02c cost of one gallon of oil.
12. The average heating boiler will evaporate  $12\frac{1}{2}$  of water per lb. of oil, this is only allowing 66 2-3 per cent efficiency.
13. Item No. 8 (18,000)  $\times$  item 12 (6 2-3) = 12,000 B.t.u. available.
14. Item No. 7 (260,000 cu. ft.) divided by item 13 (12,000) equals 21 lb. of oil necessary to burn to generate the equal amount of heat units as contained in 400 cu. ft. of gas.
15. One gallon of oil weighs about 8 lb.
16. Item No. 14 (211 lb.) divided by item No. 15, (8 lb.) = 2% gal. of oil.



- 17. Item No. 16 (2%)  $\times$  item 11 (2c) = 5¼c the cost of oil.
- 18. Item No. 3 (28) less item 17 (5¼c) = 22¾c per day saving.
- 19. The cost of operating electric motor is same for each system.

**Comparison Cost of Heating With Service Steam and Oil.**

- 1. Assuming building to have 5100 sq. ft. direct radiation.
- 2. Assuming building to have 610 Vento or indirect radiation.
- 3. 610 sq. ft. of Vento arranged as specified will condense 6 times as much water as an equivalent amount of direct radiation, or 3660.
- 4. 5100 plus 3660 = 8760 sq. ft. and is the equivalent direct radiation of the entire building.
- 5. Assuming that one sq. ft. of direct radiation together with pipe, etc., connecting same, will condense an average of 1-3 lb. of steam into water every hour.
- 6. Then 8760 divided by 3 = 2920 lb. of water per hour.
- 7. Assuming that steam is used 7 hours per day.
- 8. Then, 2920  $\times$  7 = 20,440 pounds condensed daily.
- 9. The rate charged by the steam service company at 70c per 1000 lb. of water.
- 10. 20,440 divided by 1000 and multiplied by 70c equals approximately \$14.30 as being the cost for steam service daily.
- 11. Multiply \$14.30 by 30 days = \$429.00 per month as the cost of street steam. For 12 months \$5148.
- 12. Crude oil burned in the average heating boiler will evaporate 12 lb. of water per lb. of oil.
- 13. Then 20,440 divided by 12 = 1703 lb. of oil daily.
- 14. 1703 divided by 7.8 = 206 gal. of oil daily.
- 15. Assuming that oil weighs 7.8 lb. per gallon.
- 16. One barrel of oil contains 42 gal.
- 17. 206 divided by 42 = 4.9 barrels of oil daily at 85c per barrel = \$4.15.
- 18. Two motors (1-3 and ½ h.p.) operating the two rotary systems will consume about 1000 watts per hour or 7000 watts daily.
- 19. The rate for operating the motors is about 5c per kw.-hr. or 7 times 5 = 35c per day for electric current.
- 20. \$4.15 plus 35c = \$4.50 or \$135 monthly or \$1620 yearly.
- 21. Deduct \$1620 from item No. 11 (\$5148.00) leaves a balance of \$3528 in favor of oil as fuel.

## CHAPTER XVI.

### FURNACE EFFICIENCY AND COMBUSTION.

Many engineers are satisfied when their oil fires show a bright clear flame without smoke. They overlook the fact that much unnecessary air may be passing through the furnace, under these conditions; and if low efficiencies are the result, they lay the blame on the oil burner, without making any effort to investigate or better the conditions. The time has come, however, when all engineers should pay more attention to scientific combustion. It is impossible to know when combustion is complete (without excess of air) without the use of flue gas analysis instruments; and as these are relatively cheap, they should be a part of every fire-room equipment.

The result of complete combustion of carbon is carbon dioxide,  $\text{CO}_2$ . When completely burned fuel consisting of 100 per cent carbon will show a volumetric percentage of 20.7  $\text{CO}_2$  in the furnace gases. Fuel oils contain a high percentage of carbon, and the average per cent of  $\text{CO}_2$  obtained in oil burning furnaces where furnace conditions are watched is from 13 to 14 per cent, the theoretical maximum being 15.6 per cent. The lower the percentage of  $\text{CO}_2$ , the greater the waste due to excess air. For example, if the amount drops from 13 per cent to 10 per cent, it is an indication of 54 per cent excess air, and a loss of 2.9 per cent of fuel. The table below shows the corresponding losses that occur when various percentages of  $\text{CO}_2$  are indicated in the flue gases.

Table.

Per cent CO <sub>2</sub>	CO <sub>2</sub> and Fuel Losses.		Per cent fuel loss.
	Per cent excess air.	B.t.u. loss.	
15.6	0	0	.0
15	5	75	.4
14	10	186	1.
13	18	317	1.7
12	28	447	2.4
11	40	633	3.4
10	54	856	4.6
9	70	1118	6.
8	93	1435	7.8
7	120	1900	10.2
6	152	2460	13.2
5	198	3205	17.2
4	273	4380	23.5
3	396	6340	34.
2	635	10150	54.5
1	...	.....	....

To be able to conduct the tests necessary to determine the efficiency of combustion, the engineer should be provided with a practical gas analysis apparatus. There are many such instruments on the market. The manually operated type gives oxygen (o), CO, and CO<sub>2</sub>, while the automatic CO<sub>2</sub> recorder indicates at certain intervals the percentage of CO<sub>2</sub> present in a sample of the flue gases, and automatically registers it on a chart.

In using these instruments, the sampling tube should be inserted at the base of the chimney, or in the last pass in the boiler, as near as possible to the point where the gases leave the heating surface. In order to determine the air leakage, a reading should also be taken at the furnace and compared with the reading from the last pass; the furnace should show a little higher percentage of CO<sub>2</sub>. Careful attention should be given to the leakage of air through boiler settings, and analyses should be taken comparing the CO<sub>2</sub> present to compare the difference about six inches from the wall with the amount near the center of the furnace. Such a comparison will give a good idea of the leakage that is taking place through cracks in the walls, or through porous bricks. A saving of over 5 per cent has been effected by stopping such leaks in a boiler setting that was apparently in perfect condition.

A draft gauge should be used while making the gas analyses, for a slight variation of the draft entering the furnace raises or lowers the percentage of  $\text{CO}_2$ . If the percentage of  $\text{CO}_2$  is found to be low, indicating excess air, the draft should be adjusted until the percentage of  $\text{CO}_2$  has increased.

Apparatus for Flue Gas Analysis. The Orsat apparatus, illustrated in Fig. 107, is generally used for analyzing flue gases. The burette A is graduated in cubic centimeters up to 100, and is surrounded by a water jacket to prevent any change in temperature from affecting the density of the gas being analyzed.

For accurate work it is advisable to use four pipettes, B, C, D, E, the first containing a solution of caustic potash for the absorption of carbon dioxide, the second an alkaline solution of pyrogallol for the absorption of oxygen, and the remaining two an acid solution of cuprous chloride for absorbing the carbon monoxide. Each pipette contains a number of glass tubes, to which some of the solution clings, thus facili-

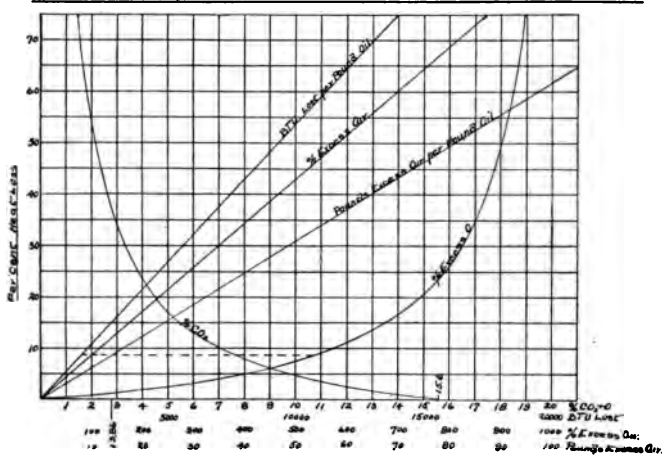

Fig. 106.  $\text{CO}_2$  Curve Showing Heat Loss Due to Excess Air.

Calculated on following conditions: Oil as fired—18,633 B.t.u., 84.73 per cent carbon; 11.74 per cent hydrogen; 1.06 per cent sulphur; 5 per cent nitrogen; .87 per cent oxygen; .7 per cent moisture, and .4 per cent sediment. Atmospheric temperature, 55 degrees F.; humidity, 88, stack temperature, 500 degrees F., Kern oil at 16 degrees B.

tating the absorption of the gas. In the pipettes D and E, copper wire is placed in these tubes to re-energize the solution as it becomes weakened. The rear half of each pipette is fitted with a rubber bag, one of which is shown at K, to protect the solution from the action of the air. The solution in each pipette should be drawn up to the mark in the capillary tube.

The gas is drawn into the burette through the U-tube H, which is filled with spun glass, or similar material, to clean the gas. To discharge any air or gas in the apparatus, the cock G is opened to the air and the bottle F is raised until the water in the burette reaches the 100 cubic centimeters mark. The cock G is then turned so as to close the air opening and allow gas to be drawn through H, the bottle F being lowered for this purpose. The gas is drawn into the burette to a point below the zero mark, the

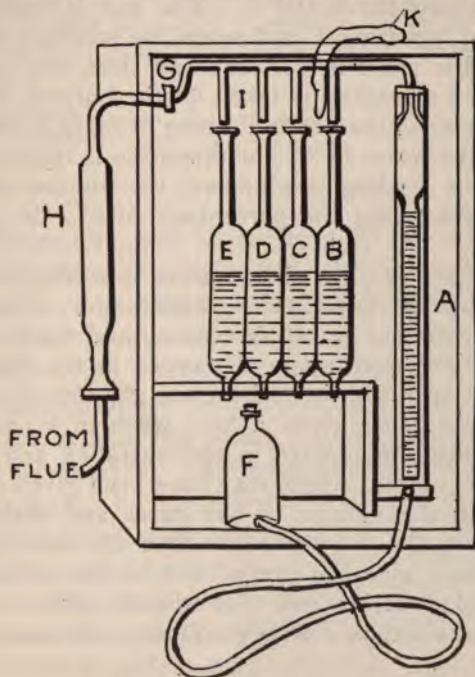

Fig. 107. Orsat Apparatus.

cock G then being opened to the air and the excess gas expelled until the level of the water in F and in A are at the zero mark. This operation is necessary in order to obtain the zero reading at atmosphere reading pressure.

The apparatus should be carefully tested for leakage, as should also all connections leading thereto. Simple tests can be made, for example, if, after the cock G is closed, the bottle F is placed on the top of the frame for a short time and again brought to the zero mark, if the level of the water in A is above the zero mark, a leak is indicated.

Before taking a final sample for analysis, the burette A should be filled with gas and emptied once or twice to make sure that all the apparatus is filled with the new gas. The cock G is then closed and the cock I in the pipette B is opened, and the gas driven over into B by raising the bottle F. The gas is drawn back into A by lowering F and when the solution in B has reached the mark in the capillary tube, the cock I is closed and a reading is taken on the burette, the level of the water in the bottle F being brought to the same level as the water in A. The operation is repeated until a constant reading is obtained, the number of cubic centimeters being the percentage of  $\text{CO}_2$  in the flue gases.

The gas is then driven over into the pipette C and a similar operation is carried out. The difference between the resulting reading and the first reading gives the percentage of oxygen in the flue gases. The next operation is to drive the gas into the pipette D, the gas being given a final wash in E, and then passed into the pipette C to neutralize any hydrochloric acid fumes which may have been given off, thus increasing the volume of the gases and making the reading on the burettes less than the true amount. The process must be carried out in the order as the pyrogallol solution will also absorb carbon dioxide, while the cuprous chloride solution will also absorb oxygen.

As the pressure of the gases in the flue is less than atmospheric, they will not of themselves flow through the pipe to the burette. For rapid work a rubber bulb aspirator connected with the air outlet of the cock G will enable a new supply of gas to be drawn into the pipe, the apparatus then being filled as already described.

Another form of aspirator draws the gas from the flue in a constant stream, thus insuring a fresh supply for each sample.

The analysis made by the Orsat apparatus is volumetric; if the analysis by weight is required, it can be found from the volumetric analysis as follows: Multiply the percentages by volume by either the densities or the molecular weight of each gas, and divide the products by the sum of all the products; the quotients will be the percentages by weight. For most work sufficient accuracy is secured by using the even values of the molecular weights, given below:

Carbon dioxide .....	44
Carbon monoxide .....	28
Oxygen .....	32
Nitrogen .....	28

Combustion may be confined by the rapid chemical combustion of oxygen with carbon, hydrogen and sulphur, accompanied by the diffusion of heat and light. That portion of the substance thus combined with the oxygen is called combustible. The principal combustible in fuel oil being carbon, hydrogen and sulphur. Carbon being the most abundant as is shown by analysis. Comparative analysis of various crude oils may be found at the front of this book.

The proportionate amount of air required for combustion is a most important question. The theoretical amount of air required to supply the oxygen for combustion can be worked out, but in practice it is impossible to obtain perfect combustion with the theoretical amount of air. Nitrogen is an inert gas and does not

aid the combustion. It passes through the furnace without any change, other than absorbing the heat of the furnace, thus reducing the temperature. It is one of the unavoidable sources of heat losses in furnaces. The reason for excess air, over the theoretical amount required, is that it is impossible to bring out each particle of oxygen in the air into intimate contact with the particles of the fuel that are to be oxidized, due not only to the dilution of the oxygen in the air by the nitrogen, but, also to the fact that the fire is too dense to allow the air to pass through it.

Statements have been made that from 50 to 100 per cent of air is required, depending upon the system and type of furnace used.

Some authorities have stated that not more than 2 to 3 pounds should be consumed per square foot of combustion space in order to insure smokeless combustion, but in practice more will be found necessary.

An excess amount of air will so lower the temperature of the furnace gases as to delay combustion to an extent that will cause carbon monoxide to pass off unburnt from the furnace. A sufficient amount of carbon monoxide in the gases may cause the action known as secondary combustion, by igniting or mingling with the air after leaving the furnace. This causes the breachings and doors to shake, also fires in the stack.

If less than the required amount of air is supplied, the carbon burns to monoxide instead of dioxide, and its full heat value is not developed, and will readily be detected by the appearance of smoke. The absence of smoke does not necessarily demonstrate or prove that the combustion is perfect, but a clear flame consumes less oil than a smoky one.

A dark red flame, slightly smoking, is nearer to complete combustion. The chemical combination of a combustible with oxygen disengages energy in the form of heat.

The quantity or measure of this heat may be expressed in British thermal units (B.t.u.), or the quan-



tity of heat required to raise the temperature of one pound of water, one degree Fahrenheit.

The number of British thermal units released by the combustion of one pound of the following substances, and the resultant temperatures are:

Hydrogen burned to H<sub>2</sub>O, 62,032 B.t.u. Temp. 5,898° F.

Carbon burned to CO<sub>2</sub>, 14,500 B.t.u. Temp. 4,939° F.

Carbon burned to CO, 4,452 B.t.u. Temp. 2,358° F.

The great loss of heat due to the incomplete combustion of carbon is shown by the difference between the total heat of perfect combustion of carbon to CO<sub>2</sub> (14,500 B.t.u.), and that of carbon to CO (4,452 B.t.u.).

One pound of carbon, when imperfectly burned produces  $\frac{12 + 16}{12} = 2\ 1\text{-}3$  pounds of carbon monoxide.

If this quantity of gas is burned to carbon monoxide, the total amount of heat released will be 14,500 — 4,452 = 10,048 B.t.u.; therefore the calorific value of

one pound of carbon monoxide is  $\frac{10,048}{2\ 1\text{-}3} = 4312$  B.t.u.

A typical analysis of petroleum is as follows:

Carbon .....	.84
Hydrogen .....	.14
Oxygen .....	.02
	1.00

Allowing the oxygen to unite with its equivalent of hydrogen to form water, the calorific value would be based upon the corrected quantities as follows:

Carbon..... .84 × 14,500 = 12,180

Hydrogen.... .1375 × 62,032 = 8,520

20,700 B.t.u.—the

calorific value of one pound of oil when its carbon is burned to CO<sub>2</sub>.

If, however, combustion is imperfect and the carbon be burned to CO, then the total heat would be:

$$\begin{aligned} .84 \times 4,452 &= 3,739 \\ .1375 \times 62,032 &= 8,529 \end{aligned}$$

12,268 B.t.u., or about 59 per cent of that obtained in the first instance. In fuel oils, having a less percentage of hydrogen, the proportionate loss would be greater.

The following report was recently made on board a large ocean going steamer in order to determine the furnace efficiency of the boilers.

"In accordance with our agreement with you we have made investigations regarding the furnace efficiency in the boilers of your steamship Queen and beg to submit the following report:

Flue gas samples were obtained from the front connection of each furnace in all of the boilers to avoid possible air leaks in the uptake and to obtain individual furnace conditions and analyzed to determine the percentage of carbon dioxide contained therein with a view to increasing same to the point of maximum efficiency. Our initial determinations revealed the fact that an unusually high percentage of CO<sub>2</sub> prevailed under ordinary running conditions. This was found to be 10.0 per cent, which was soon raised to 11.1 per cent by a few minor changes indicated by the analyses. In one particular case the furnace only indicated 7.0 per cent of CO<sub>2</sub> and an investigation revealed a dirty burner. The burner was immediately changed and the furnace then produced 11.4 per cent of CO<sub>2</sub> without alteration of draft. In another case similar conditions prevailed and the CO<sub>2</sub> content was raised from 9.0 per cent to 13.0 per cent. Two analyses were taken from each furnace in succession to check up any error or inaccuracy in the work and to avoid false observations. Except in a few isolated places the firemen seemed to be getting exceptional results and with the aid of the analyses the inferior fires were soon brought up to normal. The only guide for the firemen, however, is the expansion pyrometer in the stack

and indications of smoke in the stack and the latter case is deceiving because one furnace might easily produce all of the smoke while, in an effort to better conditions the firemen would probably alter each furnace. This, you can see, would ordinarily result in an excess of air in every furnace but one or two.

Stack temperature observations were also made during each test as indicated by an electric pyrometer, the most accurate method yet devised for high temperature measurements. This temperature varied on different watches and conditions in the fire room, but in every case where other conditions were nearly the same we find a fall in the stack temperature with an increase in CO<sub>2</sub>. The average stack temperature for the trip was found to be 715 degrees F. which is easily 50 degrees lower than the temperature in the front connection where the heat in the gases is no longer available for evaporation. The temperature in the port side of the stack was found to be about thirty degrees lower than in the starboard side under given conditions, showing the effect of the retarders in the port side. But even then the temperature was about 670 degrees under the best conditions for ordinary running.

The following table, together with its graphical representation, will serve to indicate the average results of each day's test:

Time.	Average CO <sub>2</sub> Per cent.	Engine r.p.m.	Bbl. Oil per hr.	Temper- ature.
5:28:14 Aft. ....	11.0	84.0	12.94	715
			13.	
5:28:14 P. M. ....	10.3	84.0	13.35	740
5:29:14 Aft. ....	10.6	83.5	13.17	730
5:30:14 Aft. ....	11.6		12.69	700
5:31:14 A. M. ....	11.0		12.62	720
6: 1:14 A. M. ....	11.9	83.0	12.50	730
6: 2:14 Aft. ....	11.8	83.5	12.52	690
	11.6			
6: 2:14 Aft. ....	11.6		12.90	700
7: 2:14 P. M. ....	10.8	75.1	10.48	700
Average for trip..	11.18		12.58	715

The above table represents the average results of 225 analyses, a portion of which were obtained each day during the trip.

Draft readings were also taken in several cases and it was found that under normal running conditions the furnaces required a draft of about 0.42 inches of water for proper combustion.

The inboard furnace on the forward starboard oiler equipped with the cast iron secondary damper was found to admit of more perfect control and draft regulation than the old type. Almost perfect combustion was obtained from this burner as 14.0 per cent of CO<sub>2</sub> was produced with no indications of carbon monoxide of CO.

The oil readings were obtained by a meter in the feed line which serves only as an indicator of the fuel consumption because it is bad practice to assume that a meter measures oil accurately.

Without accompanying indicator cards it is not possible to determine the oil consumption per indicated-horsepower-hour, but it can be seen from the table that where conditions are quite similar there is always an indicated decrease in the oil consumption corresponding to an increase in CO<sub>2</sub> in the flue gases.

During one period when the r.p.m. of the engine room was reduced to 75 on the 8:00 to 12:00 p. m. watch, we noted an unusual stack temperature of 550 degrees. This would tend to the conclusion that the boiler capacity is rather low for the power required in order to obtain the maximum results from the fuel. A material reduction of draft, whether it be by retarders or any other means will, in our opinion result in an insufficient supply and for that reason it seems that the boilers are being crowded when the engine has to turn up to 84 r.p.m.

The average CO<sub>2</sub> content of 11.18 per cent only represents a preventable fuel loss of 2½ per cent with conditions as prevailing in this case and it seems unreasonable to expect better results where the firing must necessarily be guess work.

A calibration of each furnace against a differential draft gauge would no doubt be of value in better regulation of the fires, but the ordinary type of draft

gauge is not suitable to marine work because of the unsteady motion of the ships.

A glance at the attached graph will indicate immediately the various effects by any definite change in conditions as it is merely a graphical representation of the table contained on page 207.

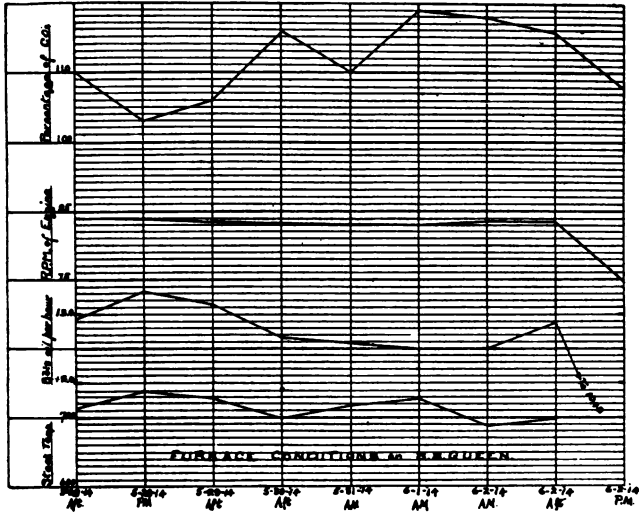

Fig. 108.

## CHAPTER XVII.

### TESTS AND REPORTS.

An engineer should know whether or not he is getting the best possible results from the fuel that he is using, and also the percentage of capacity as compared with the builder's rating. He should know how to compare the value of the different fuels. By conducting tests he can determine the results, and by making alterations in furnace designs, air admission, pressure, etc., he can determine the effect of these changes.

As shown in the chapter on combustion, the necessity of observing the conditions under which the fuel is being burned, we will now proceed to conduct a test in order to check up the results.

We must first prepare a record sheet showing the size and capacity of the holder, the analysis of the oil, with temperature, pressure, etc., as shown in comparative report. After having prepared the sheet, arrangements must be made to weigh the oil and water used during the tests.

Care should be taken to mark the height of of water in the boiler at the starting of the test, and to have exactly the same amount at the finish.

We are now ready to take the data regarding the pressures, temperatures, etc., as shown under items from 10 to 23 inclusive, pages 212 and 213. These are given for comparison and should be taken hourly and a general average made at the end of the test. The total quantities are as shown in items 24 to 31 inclusive.

In order to determine the weight of dry oil consumed, (item 25) we take the following figures:

$$\frac{100 - .07 \times 6023}{100} = 5956.7$$

The factors of evaporation being ascertained, we multiply it by the total weight of water evaporated (item 27) of item 28  $\times$  27 or  $1.0889 \times 85,392 = 92,893$ . It being the total equivalent evaporation from and at 212° F.

It is important to know this item in order to ascertain the efficiency gained by heating the feed water.

The equivalent evaporation from and at 212° F.

can be held by the following  $W \frac{H \& 32 - t}{966.6} =$  equivalent evaporation.

Where  $W$  = pounds of water per pound of fuel at the temperature of the feed water  $t$ .

$H$  = total heat of steam at the temperature corresponding to the pressure, calculated from 32° F. (found by referring to table of properties of saturated steam).

Items 30 and 31 can be ascertained by passing the exhaust steam through a steam trap and receiving it in a tank.

Items 32 to 36 can be ascertained by dividing the total quantities by the total time.

There are different rules for finding the heat value of fuels. When the analysis is known the following can be used:

Divide the fraction of one pound which consists of oxygen by 8 and subtract the quotient from the fraction of a pound which consists of hydrogen. Multiply the difference by 4.28 and add to the product the fraction of a pound which consists of carbon. Multiply the sum of 14,500 and the product will be the number of B.t.u.'s in a pound of fuel.

For oil, where the analysis is not known, B.t.u. per pound =  $18650 \& 40$  (Beaume reading 10).

Item.	Data and Results of Evaporative Tests.	Computation.	Test No. 2.
3	Kind and Number of Boilers—66" x 16' 0", Return Tub. Boilers, 2" Tubes .....	Number .....	3
4	Kind of Furnace—Front Firing .....	Drawing No. ....	B-
5	Kind of Burners—Mechanical Fuel Oil Burners .....	Make .....	Coen
6	Kind of Fuel Oil and Gravity .....	Deg. Beaume .....	Kern, 16°
7	Water Heating Surface .....	Sq. ft. ....	4472
8	Date of Test .....	Hours .....	6-21-13
9	Duration of Test .....	Hours .....	7
<b>Average Pressures, Temperatures, Etc.</b>			
10	Steam pressure by gauge in main line near boilers .....	Lb. per sq. in. ....	90.7
11	Fuel oil pressure by gauge at oil heater inlet .....	Lb. per sq. in. ....	82.0
12	Temperature of steam in main line near pump .....	Deg. Fahr. ....	190.2
13	Temperature of fuel oil before entering heater .....	Deg. Fahr. ....	331.6
14	Temperature of fuel oil leaving heater .....	Deg. Fahr. ....	102
15	Temperature of feed water entering boilers .....	Deg. Fahr. ....	258
16	Temperature of fuel water entering boilers .....	Deg. Fahr. ....	162.5
17	Temperature of flue gases leaving boilers .....	Deg. Fahr. ....	411
18	Temperature of boiler room .....	Deg. Fahr. ....	109
19	Temperature of condensed steam leaving heater .....	Deg. Fahr. ....	305
20	Force of draft in chimney near boilers .....	In. of water .....	0.125
21	Percentage of moisture in steam (main line) .....	Per cent .....	2.25
22	Percentage of moisture in steam (at oil heater) .....	Per cent .....	3.3
23	Percentage of moisture and sediment in fuel oil .....	Per cent .....	0.7
<b>Total Quantities.</b>			
24	Total weight of oil as fired .....	Lb. ....	6023
25	Total weight of dry oil consumed .....	Lb. ....	100 — (23) × (24)
			100
26	Total weight of water fed to boilers .....	Lb. ....	5956.7
27	Total weight of water evaporated, corrected for moisture in steam .....	Lb. ....	87110
28	Factor of evaporation based on temperature of feed water .....	Lb. ....	85392
29	Total equivalent evaporation from and at 212 deg. ....	Lb. ....	1,0889
30	Total steam used by fuel oil pump .....	Lb. ....	92983
31	Total steam used by fuel oil heater .....	Lb. ....	729
			581
<b>Hourly Quantities and Rates.</b>			
32	Dry oil consumed per hour .....	Lb. ....	319.2
33	Equivalent evaporation per hour from and at 212 deg. ....	Lb. ....	{35} ± {3}



35	Steam used by fuel oil pump per hour.....	Lb.							
36	Steam used by fuel oil heater per hour.....	Lb.							104.1 85.0
37	Calorific Value and Analysis of Dry Fuel Oil.								
A	Calorific value of one lb. oil by calorimeter.....	B.t.u.							
	Analysis C—85.6, H—11.39, O—0.9, N—0.52, S—1.09..								
	Capacity.								
38	Evaporation per hour from and at 212 deg.....	Lb.							18840
39	Boiler horsepower developed.....	B.h.p.							13283
40	Rated boiler horsepower.....	B.h.p.							385
41	Percentage of rated capacity developed.....	Per cent							447
									86.1
	Economy Results.								
42	Equivalent evaporation from and at 212 deg. per lb. oil fired.	Lb.							15.44
43	Equivalent evaporation from and at 212 deg. per lb. dry oil.	Lb.							15.61
44	Steam used by fuel oil pump per lb. of oil fired.....	Lb.							0.1210
45	Steam used by fuel oil heater per lb. of oil fired.....	Lb.							0.0964
46	Steam used for heating and pumping fuel oil per lb. of oil fired.....	Lb.							0.2174
47	Per cent of total water fed to boilers used for heating and pumping fuel oil.....	Per cent							1.504
									100 × [(30) + (31)] ÷ (26)
48	Efficiency of boilers.....	Per cent							80.4
									[(43) × 970.4] ÷ (37)
	Analysis of Dry Chimney Gases by Volumes.								
50	Carbon dioxide (CO <sub>2</sub> ).....	Per cent							11
51	Oxygen (O).....	Per cent							6.4
52	Carbon monoxide (CO).....	Per cent							0.0
53	Nitrogen by difference (N).....	Per cent							82.6
54	Theoretical weight of air required for combustion per lb. of oil.....	Lb.							14.03
55	Excess air for combustion.....	Per cent							39
	Heat Balance Based on Oil as Fired.								
56	Heat absorbed by boilers.....	B.t.u.							14983-80.4 %
57	Loss due to evaporation of moisture in oil.....	B.t.u.							7- 0.04%
58	Loss due to heat carried away by steam formed by the burning of hydrogen.....	B.t.u.							1251- 6.72%
59	Loss due to heat carried away in dry chimney gases.....	B.t.u.							1406- 7.55%
60	Loss due to carbon monoxide.....	B.t.u.							...
61	Loss due to heating moisture in air, humidity 30 per cent.....	B.t.u.							39- 0.31%
62	Loss due to radiation—losses unaccounted for.....	B.t.u.							947- 5.08%
63	Total calorific value of 1 lb. of oil as fired.....	B.t.u.							18633-100.00%

(30) + (8)  
(81) + (9)

Same as (33)  
(38) ÷ 34.5  
(7) ÷ (10)  
(39) ÷ (40)

Orsat Analysis.

Computed from analysis of fuel oil.  
From CO<sub>2</sub> curve for analyzed oil

(42) × 970.4

As will be seen by referring to item 37 the B.t.u.'s were obtained from a calorimeter.

A calorimeter, being an instrument for measuring the quantity of heat, a body parts with or absorbs when its temperature rises or lowers.

Item 39. The boiler horsepower developed is found by dividing the evaporation of water per hour from and at 212° F. by 34.5 (being the amount of water evaporated per one boiler horsepower from and at 212° F).

Item 40. The rated horsepower is found by dividing the water heating surface by steam pressure.

Item 41. The percentage of horsepower developed is found by dividing the boiler horsepower rating by the boiler horsepower developed.

Items 43-47 are found as per computation chart.

Item 48. The efficiency of the boiler is found by:  $15.61 \times 970.4$  divided by  $18840 = 80.4$ .

Where  $15.61 =$  equivalent evaporation per lb. of dry fuel from and at 212° F.

$970.4 =$  B.t.u. of one pound of water at 212° F.

$18840 =$  B.t.u. in one pound of oil used.

This chart was computed during the test (see Fig. 106, page 200).

Items 50 to 53 are obtained by instruments as described in chapter under combustion.

Item 54 being the theoretical amount of air required for combustion of one lb. of oil, can be found by knowing the analysis of oil, and referring to table on oxygen and air for combustion.

So, then, by referring to analysis we have:

Carbon	.856	$\times$	11.52	=	9.861 lb. of air.
Hydrogen	1189	$\times$	.3456	=	3.901 lb. of air.
Sulphur	.0109	$\times$	4.32	=	.047
					13,809

Or another more accurate formula is pounds of air required per pound of fuel

$$= 34.56 \left( \frac{C}{3} + \left( H - \frac{O}{8} \right) + \frac{S}{8} \right)$$

The first method is the most simple and will do for ordinary practice, as we always require much more than the theoretical amount.

**Oxygen and Air Required for Combustion.**

1 lb. of carbon requires 11.52 lb. of air to burn from C to  $\text{CO}_2$   
 1 lb. of hydrogen requires 34.56 lb. of air to burn from H to  $\text{H}_2\text{O}$   
 1 lb. of sulphur requires 4.26 lb. of air to burn from S to  $\text{SO}_2$

Item 56. Heat absorbed by boilers, is Item  $42 \times 970.4 = 14983$  B.t.u. or 80.4 per cent.

By comparing Item 55, showing excess air for combustion as figured from curved and with the following formula, shows the closeness. Pounds of air

supplied per lb. of fuel  $= 3.036 \left( \frac{\text{N}}{\text{CO}_2 + \text{CO}} \right) \times \text{C}$ . This is when the analysis of the flue gas is known.

$3.036 \left( \frac{82.6}{11 \times \text{O}} \right) \times .356 = 19.5$  lb. of air supplied or 41.5 per cent excess air.

After having conducted a boiler test to determine the capacity and efficiency of the boiler, it then remains to check up the losses. In the comparative test, we have a boiler efficiency of 80.4 per cent. This shows that we are only getting a little more than 80 per cent of the heat value of the fuel.

Now, then, we must proceed to check up and find out where the 20 per cent loss is taking place. We know that there are some unavoidable losses, but, we must figure them out in order to determine exactly the avoidable losses.

The loss due to the burning of hydrogen  $= 9 \times .1189 (212-109) + 970.4 + .48 (411-212) = 1237.97$ .

Knowing the weight of air required for combustion, we take  $13.809 + 100 = 14,809 =$  weight of gas per lb. of oil. Thus the loss of heat in chimney gases will be,  $14,809 \times 24 (411-109) = 1073$  B.t.u.

In order to explain some figures used:

24 being the specific heat of the gases of combustion.  
 48 being the specific heat of the superheated steam.  
 970.4 being heat required to change water into steam at 212° F.

We have shown the theoretical amount of air for combustion and the excess air amounts as figured out. Now then how near the practical amount of air did we get?

By referring to the test sheet we have under item 56, the heat absorbed by the boilers as being 14983. We know that 1 lb. of water at 212° F. has 970.4 B.t.u. So then we will divide 14983 by 970.4 = 15.44 lb. of water.

So then, if we refer again to the test sheet under item 42 we find that we have actually evaporated 15.44 lb. of water from and at 212° F. This, then, should indicate that we had during the test, the actual amount of air required for combustion.

There are many formulas used in connection with fuel oil tests for computing the economic results. As a rule they are scattered throughout many books; for convenience a few of the most important ones are shown here.

The British thermal unit or heat unit is the quantity of heat required to raise one pound of pure water, one degree F. or more exactly from 39.1° to 40.1° and equals 778 foot pounds.

A calory is the same only expressed in the metric system. To convert calories to B.t.u. = Calories  $\times$  3.96 = B.t.u. or B.t.u.  $\times$  .252 = Calories.

B.t.u. per pound of oil = 18650 + 40 (Beaume reading less 10). One pound of water at 212° F. has 970.4 B.t.u.

Fahrenheit.

32° Freezing point of water.

212° Boiling point of water.

Note.—The number of degrees between any point of Fahrenheit's scale and 32°, if divided by 1.8, will give the corresponding point on the Centigrade.

Centigrade.

Freezing point of water, zero.

Boiling point of water, 100°.

Note.—If any degree on the Centigrade scale, either above or below zero, be multiplied by 1.8, the result will, in either case, be the number of degrees above or below 32°, or the freezing point of Fahrenheit.

Efficiency of boiler,  $\frac{\text{heat absorbed per lb. of fuel.}}{\text{heat value per lb. of fuel.}}$   
furnace and grate

The specific heat of steam is measured in B.t.u. and is usually taken as .48. Hirn adopted the following formula:

Specific heat at constant pressure = 0.4304 & 0.0003779 T. T = temperature in degrees Fahr.

.48 can only be taken as correct for steam at atmospheric pressure, for other pressure and temperatures the specific heat may vary from .48 to .75.

The equivalent evaporation from and at 212° F. is obtained by the following:  $W = w \frac{H + 32 - t \text{ degrees}}{966.6}$

Where w = pounds of water evaporated per pound of oil with the feed at a temperature of t deg. F.

H = total heat of steam at the temperature corresponding to the pressure, calculated for 32° F.

W = the equivalent evaporation from and at 212° F.

The total heat of superheated steam is given by Prof. Peabody as:

$$H = 9.4805 (T - 10.38) + 857.2.$$

**DATA ON AIR FOR ESTIMATING NECESSARY AIR REQUIRED FOR COMBUSTION.**

**Volume and Density of Air of Various Temperatures.**

Tem- pera- ture. Deg.	Volume of 1 lb. of air at atmos- pheric pres- sure 14.7 lb. Cu. Ft.		Density or weight of 1 cu. ft. 14.7 lb. Lb.	Tem- pera- ture. Deg.	Volume of 1 lb. of air at atmos- pheric pres- sure 14.7 lb. Cu. Ft.		Density or weight of 1 cu. ft. 14.7 lb. Lb.	Tem- pera- ture. Deg.	Volume of 1 lb. of air at atmos- pheric pres- sure 14.7 lb. Cu. Ft.		Density or weight of 1 cu. ft. 14.7 lb. Lb.
	14.7 lb. Cu. Ft.	14.7 lb. Lb.			14.7 lb. Cu. Ft.	14.7 lb. Lb.			14.7 lb. Cu. Ft.	14.7 lb. Lb.	
0	11.583	.083331	220	17.111	.058442	575	26.031	.038415			
32	12.387	.080728	240	17.612	.056774	600	26.659	.03751			
40	12.586	.079439	260	18.116	.0552	650	27.915	.035822			
50	12.84	.077884	280	18.621	.05371	700	29.171	.03428			
62	13.141	.076097	300	19.121	.052297	750	30.428	.032865			
70	13.342	.07495	320	19.624	.050959	800	31.684	.031561			
80	13.593	.073565	340	20.126	.049686	850	32.941	.030358			
90	13.845	.07223	360	20.63	.048476	900	34.197	.029242			
100	14.096	.070942	380	21.131	.047323	950	35.454	.028206			
120	14.592	.0685	400	21.634	.046223	1000	36.811	.027241			
140	15.1	.066221	425	22.262	.04492	1500	49.375	.020295			
160	15.603	.064088	450	22.89	.043686	2000	61.94	.016172			
180	16.106	.06209	475	23.518	.04252	2500	74.565	.013441			
200	16.606	.06021	500	24.146	.041414	3000	87.13	.011499			
210	16.86	.059313	525	24.775	.040364	.....	.....	.....			
212	16.91	.059135	550	25.403	.039365	.....	.....	.....			

Where  $H$  = total heat in the steam above that in water at  $32^{\circ}$  F.

$T$  = absolute temperature F.

$P$  = absolute pressure of steam in the lb. per sq. ft.

Peabody takes  $T = 460.7$  & the ordinary temperature.

$$\text{Factor of evaporation} = \frac{H - h}{970.4}$$

Where  $H$  = the total heat of steam above  $32^{\circ}$  F.

$h$  = sensible heat of feed water above  $32^{\circ}$  F.

The weight and volume of air depends upon the pressure and the temperature expressed by the formula  $Pv = 53.33 T$ .

Where  $P$  = the absolute pressure in lb. per sq. ft.

$V$  = the volume in cu. ft. of one lb. of air.

$T$  = the absolute temperature of the air in deg. F.

55.33 = the constant for air derived from the ratio of pressure, volume, and temperature of a perfect gas.

Air for combustion has been shown, but this formula is often used:

$$W = 11.6 C + 34.8 H.$$

Where  $W$  = pounds of air per pound of oil

$C$  = percentage of carbon.

$H$  = percentage of hydrogen.

For commercial purposes fuel oil is classified, marketed and designated by its specific gravity. Specific gravity is the ratio of a weight of a substance to the weight of an equal volume of water.

The specific gravity of liquids is measured most conveniently by an instrument known as a hydrometer. It consists of a stem or tube of glass of uniform diameter marked with graduations from 10 to 100; a bulb containing air, and a small bulb at the bottom containing shot or mercury, which causes the instrument to float in the liquid in a vertical position.

The hydrometer, when placed in a receptacle containing oil, sinks to a point on the scale which indicates the gravity Beaume. The temperature for which

the Beaume scale is graduated is 60° F. or 15.5 C. and for any variations in temperatures, connections must be made.

**Corresponding Pressures and Velocities of Dry Air at 70° and 29.92" Barometer.**

Inches of water.	Ounces per sq. in.	Velocity ft. per min.	Inches of water.	Ounces per sq. in.	Velocity ft. per min.
.05	.0289	896	4.77	2.750	8745
.10	.0577	1266	5.00	2.884	8943
.20	.1154	1791	5.20	3.000	9134
.25	.1443	2003	5.50	3.172	9392
.30	.1730	2193	6.00	3.460	9810
.40	.2308	2533	6.07	3.500	9864
.43	.2500	2637	6.50	3.749	10210
.50	.2884	2832	6.94	4.000	10545
.60	.3460	3102	7.00	4.037	10595
.70	.4037	3351	7.50	4.326	10968
.75	.4326	3468	7.80	4.500	11187
.80	.4614	3582	8.00	4.614	11323
.87	.5000	3729	8.67	5.000	11792
.90	.5190	3800	9.00	5.190	12015
1.00	.5768	4005	9.54	5.500	12367
1.25	.7209	4478	10.00	5.768	12665
1.30	.7500	4566	10.40	6.000	12915
1.50	.8650	4905	11.00	6.344	13282
1.73	1.0000	5273	11.27	6.500	13445
1.75	1.0092	5298	12.00	6.921	13875
2.00	1.1535	5664	12.14	7.000	13950
2.17	1.2500	5895	13.00	7.497	14440
2.25	1.2975	6007	13.87	8.000	14913
2.5	1.4418	6332	14.00	8.074	14985
2.60	1.5000	6457	15.00	8.650	15510
2.75	1.5860	6641	15.61	9.000	15820
3.00	1.7300	6937	16.00	9.227	16020
3.03	1.7500	6976	17.00	9.805	16513
3.25	1.8740	7220	17.34	10.000	16675
3.47	2.0000	7457	18.00	10.380	16990
3.50	2.0185	7492	19.00	10.960	17456
3.75	2.1630	7756	19.07	11.000	17488
3.90	2.2500	7910	20.00	11.535	17910
4.00	2.3070	8010	20.81	12.000	18265
4.25	2.4510	8256	22.54	13.000	19012
4.34	2.5000	8337	24.28	14.000	19730
4.50	2.5950	8496	26.01	15.000	20420
4.75	2.7395	8729	27.74	16.000	21090
water.	sq. in	min.	water	sq. in.	min.







## CHAPTER XVIII.

### OIL FOR GAS MAKING.

The use of oil for gas manufacture was first invented by Prof. Lowe in February, 1874, at Phoenixville, Penn. The process was described by him as follows:

"The basic principles involved were the use of a generator and superheater, both shells lined with fire brick. The former was provided with grate bars, air blast and steam connections; the latter was filled with loosely piled checker brick, to give fixing surface. In the generator, non-luminous water gas was produced by the dissociation of steam in contact with carbon (in the form of anthracite coal), previously heated to incandescence by means of a forced blast of air. The superheater was brought to a suitable temperature for breaking up oil vapors by the combustion within it of the carbonic oxide formed during and by the passage of the air blast through the fuel in the generator. Oil, or oil vapors were introduced into the superheater coincident with the generation of the non-luminous water gas in the generator, and by contact with the heated fire brick surfaces the oil vapors were gasified and fixed, in the presence of the non-luminous gas and during their passage together through the superheater. The process is, necessarily intermittent: first a period of blasting to bring the carbon in the generator to the proper temperature, and by complete combustion of the blast gases in the superheater to bring the checker work brick to the proper temperature for fixing the oil vapors; second, a period of gas production."

This gas was called "carburetted water gas," and a high grade oil was used, mostly naphtha. There was very little demand for this grade of oil in those days, in fact the refiners had trouble in disposing of it.

When the cost of naphtha increased the manufacturers of water gas were compelled to look for a cheaper grade of oil. The crude oils of Pennsylvania having a paraffin base are very valuable for refining lubricating oil, and crude oils from other fields had to be obtained.

Improvements were made in the type of generator and the double superheater type came into general use in making water gas. The first water gas made in Phoenixville required about 75 lb. of anthracite coal, and 4½ gallons of oil for each 1000 cu. ft. of 23 candle power gas. In latter years with the improved double superheater type of generator, a water gas of 27.6 candle power was made from about 40 lb. of Welsh anthracite coal and 4.36 gallons of oil.

The modern process of operation may be described as follows. A bed of anthracite coal is laid on the fire bars, and blown to a bright red heat by means of the air blast, furnished by a blower engine. The air in passing through the fuel not only raises its temperature, but also forms producer gas, which burns in the carbureter and the superheater, on being mixed with further supplies of air at these points. In this way the checker brick in these vessels is raised to a high temperature, while the spent gases pass out of the stack, the stack valve being open while the valve in the pipe leading to the condenser is closed. When the necessary temperature is reached, the air blast is shut off, the stack valve closed, and the gas valve opened. Steam is turned into the generator below the incandescent fuel; this steam, coming into contact with the carbon, forms water gas which passes at high temperature into the carbureter. Here it meets a supply of hot oil which is being sprayed over the checker; oil gas is formed and mixes with the water gas, the mixture going forward to the superheater and then to the condensers. When the temperature of the apparatus falls too low for the steam to combine with carbon and for the oil to be gasified by the checker work the steam and oil are turned off, the stack valve opened, the blast started, and the heating recommences. The process is thus an intermittent one, the periods of

heating up and gas making being usually about equal, ranging from five to twenty minutes each. This apparatus performs two distinct functions: to manufacture pure water gas, and to mix this with oil gas.

The generator for the manufacture of what is known as "crude oil water gas" is very similar to that used for ordinary water gas; in fact, under one system the old apparatus is converted to the new use by constructing checker work in the generator proper and placing the oil burners at the top instead of at the bottom. But the greatest success is obtained where the apparatus is specially constructed for the purpose. In this apparatus, the generator, instead of a bed of fuel, has a fire brick checker, which is heated by means of oil burners, carbon being at the same time deposited on the brick. The proper heat in the generator and superheater being attained, the air supply is shut off, and the steam and oil introduced, as in making ordinary water gas. The steam combines with the carbon on the checkers, forming water gas, while the oil is decomposed to form oil gas, which is fixed in the usual manner. The apparatus, like the usual water gas sets, is intermittent in its action.

The making of crude water gas does not require any special grade of oil. It is made from the heavy Californian and Mexican oils as well as from the lighter grades of Texas oils, and either the crude oil from the wells, or its distillates or residuums may be used. The amount of oil required per 1000 cubic feet depends upon the grade of gas, but general it requires about 8 gallons per 1000 cubic feet in large plants, and about 12 gallons per 1000 cubic feet in small plants.

In the past ten years great progress has been made in the making of gas from crude oil. For years the one feature which has prevented oil from being an ideal material for gas manufacture has been the large percentage of the rich hydro-carbons which are dissociated, only the hydrogen portion of which appears in the gas, the carbon being a by-product. The severe treatment of the oil with extremely high heats was the cause of the production of lampblack in the

early oil gas, and the proportionately poor quality of the gas. It was not alone the extreme temperature but, the lack of uniformity of temperature. The high temperature is what is called "false" or "surface heat"; that is, the actual temperature existed, but its capacity for doing work in the breaking up of the oil was lacking. The extreme temperature existed only during the beginning of a run or gas making period and in the latter part of the run, the temperatures were far below any now utilized for gas making. If this had not been the case the efficiency of the early gas would have been extremely high, only the quality of the gas being low; and if uniform heats had been used, the early gas man would have encountered no scrubbing troubles other than the removal of lampblack; tar would have been unknown.

It was not unusual to have from 30 to 35 lb. of lampblack from each 1000 cubic feet of gas made, and in a large gas plant manufacturing 6,000,000 cubic feet of gas daily this was a very important item. The lampblack as it was removed from the separators contained from 50 to 60 per cent water, and it was necessary to drain off this water, until it was reduced to about 30 per cent, before it could be used as a fuel. Only a certain amount of this lampblack could be used under the boilers, so it became necessary to find a market for the balance. The lampblack was made into briquettes and sold for domestic use; these made an ideal fuel for use in open grates, as may be seen from the following analysis, which was made of a briquette that had been stored for nearly one year:

**Analysis.**

	Per cent.
Moisture .....	8.5
Volatile matter .....	10.8
Fixed carbon .....	79.9
Ash .....	.8
Total .....	100.00

Tests have been made at various times during the process of oil gas manufacture and the following gives the results of a typical run:

<b>Results.</b>					
	1st Min.	2d Min.	5th Min.	7th Min.	10th Min
Carbonic acid..	1.8	1.3	0.0	0.0	0.0
Illuminants ..	8.6	2.1	5.0	5.8	7.8
Oxygen .....	Tr.	Tr.	Tr.	Tr.	Tr.
Carbonic oxide	5.6	20.2	9.4	8.2	14.6
Hydrogen ....	31.7	44.1	46.6	44.9	47.4
Marsh gas....	43.4	26.7	35.7	37.3	25.9
Nitrogen .....	8.9	5.6	3.3	3.8	4.3
B.t.u. ....	765.0	549.0	675.0	698.0	747.0
Spec. Grav....	.514	.469	.402	.411	.435
Minute. Cubic Feet.		Oil 320 gallons to make			
1st .....	5,625	60 gallons to heat			
2d .....	5,833	380 gallons total			
3d .....	6,041				
4th .....	5,625	8.25 gallons of oil per 1000 cubic feet.			
5th .....	5,416	7½ minutes primary oil off.			
6th .....	5,000	8th minute secondary oil off.			
7th .....	4,373				
8th .....	4,166				
9th .....	3,125				
10th .....	3,833				
Total .....	46,041				

To determine the part played by the steam in making gas the following runs were made first, in the ordinary way; second, with oil injected under its own pressure without steam; third, by steam without the use of any oil. In each case the test was made after the generator had been heated ready to make gas:

<b>Results.</b>			
Composition.	Ordinary Run.	All Oil.	All Steam.
Carbonic acid.....	0.4	0.4	43.8
Illuminants .....	5.2	6.2	0.0
Oxygen .....	0.1	0.1	0.2
Carbonic oxide .....	7.0	5.3	10.6
Hydrogen .....	46.6	47.9	5.0
Marsh gas .....	30.6	36.7	0.0
Nitrogen .....	5.1	3.4	40.4
B.t.u. ....	668.302	700.746	53.55
Specific gravity .....	.404	.388	1.168

Ordinary run—Same pressure as combined oil and steam runs, 17 inch pressure inside machine, 47 gallons a minute.

All oil run—18 lb. to 19 lb. pressure, on primary, 25 to 27 lb. oil pressure on secondary; 21 inch pressure inside machine; 51 gallons a minute.

All steam run—25 lb. pressure on heat burners; 26 lb. pressure on primary make burners; 32 lb. pres-

sure on secondary make burners; 10 to 11 inch pressure inside machine.

The run made with all steam cannot be directly compared with the other two runs, as very little gas was produced; barely enough to enable the taking of a sample at the wash box. The generator at this period was at the same temperature as during ordinary runs; that is, it was at a temperature high enough to decompose steam in the presence of incandescent carbon, and only 10.6 per cent of carbonic oxide was produced. Had there been much carbon deposited on the checker brick, this generator would have been in ideal condition for the manufacture of blue water gas.

It was discovered that at some point, between the extremes of temperature, the oil was subjected to the proper degree of heat, a good quality of gas being produced with efficient results. But this point was quickly reached and more quickly passed, and the results obtained were lost in the aggregate. By a process of elimination, we may assume that if one temperature is right for reforming the oil, all the rest must be wrong. Working on this theory, the effort has been toward the maintenance of a uniform temperature, thus treating all the oil alike. The greatest mechanical development tending to unify the heat to which the oil is subjected was the improvement of the two-shell machine with the gas offtake located between the point of combustion of the oil used for heating the generator and the stack valve. It has been definitely proved not only by experience, but by careful tests, that the heat of the checker brick or heat reservoirs immediately adjacent to the stack valve and also the point where the initial combustion of the heat oil takes place is "false heat" or "surface heat," and is not the substantial heat which we find in the checker brick in the central portion of the generator. This is due to the fact that when oil is injected into the machine together with a forced blast of air for heating the apparatus, combustion is not immediately complete, but the heat of the checker brick is utilized in a gradually lessening degree to convert oil into a gaseous or more easily combustible state until

the combustion is complete. The following three samples of combustion products will show more clearly :

	CO <sub>2</sub>	C <sub>2</sub>	N <sub>2</sub>
Sample No. 1.....	14.2	0.0	85.8
Sample No. 2.....	15.0	0.0	85.0
Sample No. 3.....	15.4	0.0	84.6

These samples were taken simultaneously at increasing distances from the combustion chamber, the increasing percentage of CO<sub>2</sub> showing the combustion to be more nearly complete some distance from the initial point of combustion. In order to minimize the loss of heat at the stack, the combustion should be regulated so that the maximum liberation of heat is in the central portion of the checker work and the checker work nearest the stack gets only the end of the combustion, so that while the brick there may attain a high temperature, they do not contain any great quantity of heat.

A result of these peculiar combustion conditions is the inverse variation of the temperatures in the two ends of a generator if the combustion end is excessively hot, the stack end will be proportionately cool. From this fact, the two-shell machine, with the gas offtake located at an intermediate position, derives its undisputed advantage over all other forms of generators, the natural balance of heat in the two shells maintaining a uniform quality and production of gas at all times.

In the two-shell sets where oil is injected with steam into the top chamber of both the long and short shell simultaneously, and the gas offtake is located in the lower half of the long shell, the first temperature to which the oil is subjected is not the maximum temperature. The checker brick in the upper portion of each shell, with which the oil first comes in contact, do the greatest amount of work and are the regulators which limit the quantity of oil per run, but the temperature of these bricks does not constitute the fixing or superheating temperature to which the gas is subjected in the central portion of the long shell near the offtake. While the temperatures in the upper portion of the checker brick in each shell, to



which the oil and steam are first subjected, vary several hundred degrees Fahrenheit during a run, the super-heating or fixing temperatures remain fairly constant.

Mr. L. B. Jones of the Pacific Gas & Electric Company recently conducted at San Francisco a series of experiments in order to reduce the amount of lamp-black per 1000 cu. ft. of gas made. He worked along the line of combining into one process what was formerly accomplished in two; with two spare double shell sets he was able to develop what is now known as the "Improved Jones Oil Gas Set."

It will be noticed that this set has a long and short shell connected at the bottom by a large throat piece, the top of the short shell being the blast inlet, and

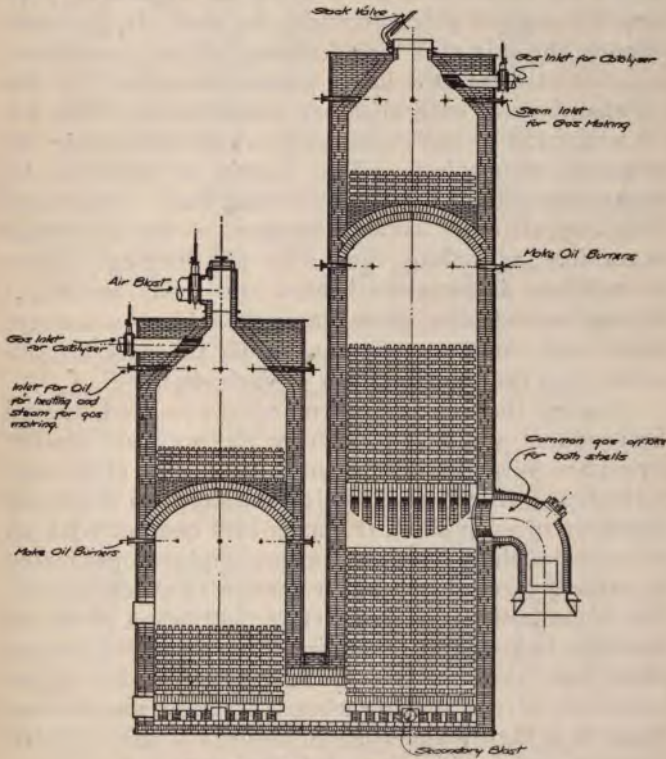

Improved Jones Oil Gas Set.

the top of the long shell the stack valve. The common gas offtake is located on the middle of the side of the long shell. The bricking and checker-work are so arranged as to form double chambers in the upper end of each shell. Short piers in the bottom of each shell support the main checker up about two-thirds of the height of the short shell and three-fourths the height of the long shell. At this point, open arches are sprung across the shell forming the tops of the lower chambers and supporting the upper sets of checker-work. About twelve courses of checker-work rest on each of these arches, and the top of this checker, and the corbel work, forms the top chamber of each shell.

Into the top chamber of the primary or short shell extend the oil burners for heating the apparatus, connected to coils of pipe encircling the shell. In the same manner, the injectors for admitting oil for gas-making are connected into the lower primary chamber. To the top chambers of each shell are connected gas lines for the admission of gas under pressure for producing the catalytic atmosphere. This supply is regulated by valves controlled from the operating floor. Into these chambers also are steam connections for supplying steam for gas-making, and also for purging. After the machine is properly heated and ready for a gas making period, the stack valve and blast valve are closed, and the gas and steam under pressure are admitted into the top chambers of each shell.

During the first minute, no oil is admitted, and all the products of combustion from the previous heating period are purged from the machine. Thus at the end of the first minute, when oil is admitted into the lower chambers of each shell, it comes into contact with an active atmosphere of gas and steam, highly superheated by passing through the upper section of checker brick. The decomposition or destructive distillation of the oil therefore begins and is continued in an active atmosphere, and when the excess carbon is freed by the reformation of the hydro-carbons, it is surrounded by steam in a highly superheated condition ideal for dissociation and combination with this carbon.

With this new process a much better gas is made and the lampblack has been reduced to about 5 lb. per 1000 cubic feet of gas. It has not only effected a saving in the oil required, but it has eliminated a great deal of the smoke that was a nuisance around gas plants. It may seem strange to note that the catalytic atmosphere is produced by using gas direct from the storage holders, but the results that were obtained proved that it was the proper thing to do.

The following report was taken from a Jones set at the Metropolitan works in San Francisco:

**Analysis Sheet, No. 4 Jones Set, Metropolitan, (14 Minute.)**

Min-utes.	Gross Make.	Purge Gas.	Net Make.	Prim. Oil.	Sec. Oil.	Total Oil.	Degrees Fahrenheit.		
							Prim. Temp.	Sec. Temp.	Neck Temp.
0							1,700	1,620	1,690
1	1,233	700	533				1,660	1,600	1,690
2	1,416	700	716	2.7	3.3	6.0	1,640	1,590	1,690
3	4,658	600	4,058	14.3	17.4	31.7	1,620	1,570	1,680
4	2,704	700	3,007	11.0	13.3	24.3	1,610	1,560	1,680
5	4,098	700	3,998	12.6	15.4	28.0	1,600	1,560	1,680
6	5,171	700	4,471	16.8	20.5	37.3	1,560	1,570	1,680
7	5,098	700	4,398	15.2	18.4	33.6	1,550	1,560	1,670
8	4,146	600	3,536	11.3	13.8	25.1	1,560	1,560	1,670
9	3,610	700	2,910	9.7	11.7	21.4	1,550	1,550	1,670
10	3,658	700	2,958	11.8	14.3	26.1	1,550	1,550	1,670
11	4,414	700	3,714	15.1	18.4	33.5	1,520	1,550	1,670
12	4,524	700	3,824	9.9	12.1	22.0	1,510	1,560	1,660
13	1,901		1,901				1,520	1,480	1,650
14	780		780				1,520	1,480	1,650

48,404 8,200 40,204 130.5 158.5 289.0

Make Oil.....289.0 = 7.2 Gals. per M.

Heat Oil..... 45.8 = 1.13 Gals. per M.

Total Oil.....334.8 Gals. = 8.33 Gals. per. M.

Net Gas Made..40204 Cu. Ft.

**Run No. 5, No. 4 Jones Set, Metropolitan (14 Minute.)**

Min-utes.	Net Make.	CO <sub>2</sub>	CnH <sub>2</sub> n	O <sub>2</sub>	CO	H <sub>2</sub>	CH <sub>4</sub>	N <sub>2</sub>	Sp Gr.	B.t.u.
1	533	22.0	0.0	0.0	7.6	9.8	15.3	45.3	.940	224
2	716	18.8	1.0	0.0	11.2	26.5	22.4	20.1	.743	389
3	4,058	4.0	4.8	0.0	8.6	40.4	37.2	5.0	.473	663
4	3,007	3.2	5.8	0.0	7.0	44.3	36.4	3.3	.437	683
5	3,398	3.0	6.2	0.0	6.4	44.1	36.6	3.7	.438	691
6	4,471	1.6	6.4	0.0	4.4	43.3	40.9	3.4	.421	731
7	4,398	1.6	7.6	0.0	4.2	41.4	41.9	3.3	.431	759
8	3,536	2.0	8.8	9.0	4.6	41.4	40.2	3.0	.442	767
9	2,910	2.6	6.7	0.0	6.1	44.2	37.4	3.0	.431	708
10	2,958	2.2	7.3	0.0	5.1	40.8	40.6	4.0	.447	740
11	3,714	1.8	8.0	0.0	4.2	39.6	42.3	4.1	.447	764
12	3,824	1.8	8.2	0.0	3.6	39.4	42.5	4.5	.448	768
13	1,901	6.9	4.3	0.0	15.0	57.4	15.4	1.0	.427	499
14	780	8.8	3.5	0.0	15.3	59.9	12.1	.4	.429	458

Total, 40,204

Av. analysis.. 3.2 6.6 0.0 6.1 42.2 37.5 4.4 .452 700

Drop in Purge gas in 3d minute affected 4th minute's gas.

Drop in Purge gas in 8th minute affected 9th minute's gas.

## INDUSTRIAL USES OF FUEL OIL

## Analyses of Various Gases.

Kind of Gas.	Illumi- nants. Cn H <sub>2</sub> n	Marsh Gas. CH <sub>4</sub>	Hydro- H <sub>2</sub> gen.	Car- bonic CO Oxide.	Car- bonic CO <sub>2</sub> Acid.	O <sub>2</sub> Oxygen.	Nitro- N <sub>2</sub> gen.	SP. GR.	Candle Power.	B.t.u.
Coal gas, Manchester, 1857.....	6.46	34.90	45.58	6.64	3.67	0.00	2.75	.435	16.0	683
"Blue" water gas.....	0.00	2.20	50.00	39.75	4.60	0.35	3.10	.537	Nil	322
Carburetted water gas, anthracite coal.....	13.00	16.00	32.00	29.00	4.50	0.50	5.00	.630	24.0	641
Early oil gas (Lowe).....	6.20	25.60	62.40	3.00	0.20	0.40	2.20	.303	18.6	624
Oil gas, Oakland.....	5.00	26.30	55.00	7.70	1.80	.0.10	4.10	.375	18.4	598
Oil gas, Potrero.....	7.01	34.64	39.78	9.21	2.62	0.16	6.58	.482	19.69	680
Carb. water gas, lampblack.....	16.50	32.80	24.60	13.70	6.20	0.20	6.00	.647	28.5	814
San Francisco, Potrero mixed.....	9.80	31.00	38.90	11.00	4.40	0.40	4.50	.516	23.0	700
New process, Metropolitan.....	6.00	40.40	41.40	5.30	2.00	0.10	4.30	.440	19.60	714
Natural gas, Pennsylvania.....	0.31	92.60	2.18	0.50	0.26	0.34	3.61	.565	Nil	1000
Natural gas, Stockton, Cal.....	0.00	76.10	0.00	0.00	0.20	0.40	23.30	.655	Nil	816
Natural gas, Sacramento, Cal.....	0.00	80.00	0.00	0.00	0.00	0.00	20.00	.638	Nil	858
Pintsch gas.....	38.10	57.70	3.40	0.50	0.00	0.00	0.00	.690	60.32	1390
Oil producer gas.....	1.60	4.60	4.60	15.40	5.80	0.20	67.80	.942	Nil	150
Producer gas, Mond gas.....	0.00	2.00	24.3	13.8	13.9	0.00	46.0	.820	Nil	153
Producer gas, Dowson gas.....	0.31	0.31	18.73	25.07	6.57	0.03	48.98	.837	Nil	161

## INDEX

### A

- Analysis of Mexican oils, 9.
- Analysis of various oils, 10, 205.
- Analysis of various gases, 232.
- Air, for combustion, 204, 217.
  - Excess air, 204.
  - losses due to excess air, 200.
  - Table on, 219.
  - Theoretical amount, 214.

### B

- Boiler arrangement.
  - Tubular, 27.
  - Water tube, 28.
  - B. & W. marine, 29.
  - B. & W. stationary, 31.
  - Parker, 80.
  - Scotch marine, 32, 33, 34.
  - Mechanical burner front, 35.
  - Upright, 36.
- Brick making.
  - Reports, 64, 67.
  - method of burning, 71.
- Brass.
  - Report on furnaces, 128, 129, 138.
- Burners,
  - Best, 40.
  - Witt, 41.
  - Wilgus, 42.
  - Hammell, 43.
  - Schur's, 43.
  - Grundell-Tucker, 44.
  - Heresoff, 44.
  - Lassoe-Lovekin, 45.
  - Fitzsimmons, 46.
  - Holden, 46.
  - Staples & Pfeiffer, 47.
  - Jarvis, 48, 176, 178.
  - M. & W. rotary, 48.
  - Mechanical, 49.
  - Naval, 49.
  - Peabody, 51.
  - Portable, 126.
  - Spray, 145.

### Burners—Continued.

- Coen, 147.
- White, 148.
- Koerting, 150.
- Dahl, 152.
- Tate Jones, 152.
- Vulcan, 179.
- Johnson, 167, 170.
- Fessco, 174.

### C

- Comparative value of oil, 3, 4, 5.
- Comparative value of oil and wood, 8.
- Comparative value of oil and coal, 4.
- Chimneys, height required, 37.
  - Table of capacities, 39.
  - at high altitudes, 38.
- Cement,
  - Process of making, 76.
  - Rotary kiln, 77.
  - Report on kilns, 78.
  - General arrangements, 80.

### D

- Distillation of crude oil, 11.
- Domestic uses of oil in homes, hotels, apartment houses, etc., 166.
- Installation in country home, 167.
- Installation in cooking stove, 169, 170, 174.
- Installation in heating boilers, 171.
- Installation in bake ovens, 174, 178.
- Report on government installation, 171.
- Oil required for heating, 192, 193.
- Comparative costs, 192, 196, 197.

**E**

- Enamel Ware, 67.
  - Process of burning, 67.
  - Type of kiln, 68.
  - Heat required, 69.

**F**

- Furnace efficiency, 198.
  - results of complete combustion, 198.
  - The Orsat apparatus, 200.
- Fire, kind of, 204.

**G**

- Gloss kiln, 70.
- Glass,
  - Process of making, 81.
  - Plate glass, 82.
  - Window glass, 83.
  - Pressed glass, 86.
  - Annealing furnace, 85.
  - Regenerative type of furnace, 87.
  - Pot furnaces, 89.
- Gas,
  - Carburetted water gas, 222.
  - Water gas, 223.
  - Crude water gas, 224.
  - Reports of making, 226.
  - Improved oil gas set, 229.
  - Report on improved oil gas set, 231.
  - Analysis of gases, 232.
  - Lampblack from, 225.

**H**

- Heat losses with coal.
- Heaters, necessity of, 56.
  - Condensing type, 56.
  - Corrugated type, 57.
  - Multi-unit type, 58.
- Hydrogen, loss due to, 215.

**K**

- Kilns, various types, 63.
  - Burners for, 64.
  - Arrangement for fire place, 66.

**L**

- Lime,
  - Composition, 73.
  - Process of burning, 73.
  - Type of kiln, 74, 75.
  - Report on kilns, 76.
- Locomotives,
  - Early reports of oil, 90.
  - Arrangements of fire box, 93, 95.
  - Details of tenders, 94, 96.
  - costs of operating, 98.
  - costs of changing to oil, 99.
  - comparison reports on, 100.

**M**

- Measurement of oils, 7.
- Metallurgical furnaces, 118.
  - Reports on, 118, 119.
  - Crucible furnace, 120.
  - Heat treating furnace, 123.
  - Reports from practice, 127.

**N**

- Naval and maritime,
  - Early investigations, 143.
  - Mechanical burners, 145, 147, 149, 150.
  - Tests and reports, 155, 156, 157, 163, 164.
  - Regulations (U. S.), 158.
  - Lloyd's rules, 160.

**O**

- Oxygen required for combustion, 215.

**P**

- Plate 1. Dew oil smelting furnace, 112-A.
- Purchasing fuel oil, 6.
- Properties of different oils, 10.
- Production of oil, 12.
- Pumping systems,
  - Witt, 23.
  - Staples & Pfeiffer, 22.
  - Union Iron Works, 24.
  - Ray's low pressure, 25.

**R**

- Regulations for storage tanks, 13 to 19.
- Regulators, for oil and steam, 59.
- Automatic fire and draft, 60.
- Rubber,
  - Bagasse from plant, 105.
  - Value as a fuel, 105.
  - Report of test, 104.
- Rivet Heating Furnace, 122.
- Rotary system of burning oil, 181.
- U. S. Government tests, 181.
- Fess system, 184.
- Ray's system, 188.
- M. & W. system, 190.

**S**

- Storage tanks throughout the country, 1.
- Strainers, 52.
  - Basket type, 52.
  - method of connecting, 53.
  - necessity of, 52.
  - Duplex type, 54.
  - Self-cleaning type, 55.
- Sugar,
  - Bagasse as fuel, 101.
  - Analysis of bagasse, 102.
  - Oil required with bagasse, 102.

**Sugar—Continued.**

- Type of furnace, 103, 105.
- Smelting furnaces, 107.
- Report on reverberatory, 108.
- Plan of reverberatory furnace, 109.
- Comparison reports, 110.
- Experimental furnaces, 113, 116.
- Blast furnace, 115.
- Steel furnaces,
  - Open hearth, 133.
  - Reports on, 137, 139.
  - Heat balance on a, 140.
  - Crucible steel furnace, 142.

**T**

- Tanks, capacity of, 14.
- Steel, thickness of, 19.
- Galvanized, 19.
- Reinforced concrete, 19.
- Tank cars, unloading of, 20, 21.
- Tests, importance of, 210.
- How to conduct, 211.
- Table of, 212-213.
- Comparative steam tests, 221.
- Comparative air tests, 220.

**W**

- Weight of oil,
- Weight of air, 217.

